



Winthrop Victory

Design type: VC2-S-AP2

Official Number: V-77



PRINCIPLE CHARACTERISTICS

BUILDER: CALIFORNIA SHIPBUILDING CORP.

BUILT: 1945

LOA: 455'-0"

BEAM: 62'-0"

DRAFT: 28'-0"

SPEED: 15-17 KNOTS

PROPULSION: B&W OIL FIRED BOILERS, TWO STEAM TURBINES, SINGLE PROPELLER, 6,000 SHAFT-HORSEPOWER

TONNAGE: 7,612 TONS(GROSS)
4,555 TONS (NET)

DISPLACEMENT: 15,200 TONS (FULL LOAD)
10,750 TONS (LIGHTWEIGHT)

COMPLEMENT: 62 CREW
28 GUNNERS

ARMAMENT: 3"/50 CALIBER GUN
5"/38 DUAL PURPOSE GUN
8 20MM CALIBER GUNS



THE SS WINTHROP VICTORY, CIRCA 1945 (NARA)



NOTE: SELECTED PORTS OF CALL

DURING WORLD WAR II, A NEW CLASS OF CARGO SHIPS ENTERED SERVICE CALLED THE VICTORY, AND THESE FAST, LONG-RANGED VESSELS SUPPLANTED THE LIBERTY SHIP. THE MARITIME COMMISSION ORDERED 272 VC2-S-AP2S IN 1944 AND 1945, OF WHICH THE WINTHROP VICTORY IS AN EXAMPLE. THIS CLASS REMAINS NOTABLE BECAUSE IT WAS THE FIRST OF A NEW GENERATION OF GENERAL CARGO SHIPS DESIGNED TO BE BUILT QUICKLY AND TO SUPPLY THE WAR IN EUROPE AND THE PACIFIC.

THIS RECORDING PROJECT WAS COSPONSORED BY THE HISTORIC AMERICAN ENGINEERING RECORD (HAER) AND THE U.S. MARITIME ADMINISTRATION (MARAD). THE VESSEL WAS DOCUMENTED UNDER THE DIRECTION OF TODD CROTEAU, HAER MARITIME PROGRAM CO-ORDINATOR AND ERHARD KOEHLER, MARAD SHIPS DISPOSAL CO-ORDINATOR. TEAM MEMBERS INCLUDED ARCHITECT ASHLEY T. WALKER, PHOTOGRAPHER DAVID HAAS AND HISTORIAN BRIAN CLAYTON.

WINTHROP VICTORY (V77)
SUISUN BAY RESERVE FLEET
SOLANO COUNTY

SCANNED FROM HISTORIC DRAWINGS AND REFORMATTED BY: ASHLEY T. WALKER, 2010

HAER MARITIME
RECORDING PROGRAM
NATIONAL PARK SERVICE
UNITED STATES DEPARTMENT OF THE INTERIOR

BENICIA VICINITY

CALIFORNIA

SHEET 1 OF 6

HISTORIC AMERICAN
ENGINEERING RECORD
CA-345

INDEX NUMBER

REPRODUCED, PLEASE CREDIT THE HISTORIC AMERICAN ENGINEERING RECORD, NATIONAL PARK SERVICE, NAME OF DELINEATOR, DATE OF DRAWING

HISTORIC AMERICAN ENGINEERING RECORD

WINTHROP VICTORY (V-74)

HAER No. CA-345

Location: Suisun Bay Reserve Fleet, Benicia vicinity, Solano County, California

Type of Craft: VC2-S-AP2/Auxiliary

Trade: Cargo transport

Class: *Victory*

Principal Dimensions: Length (oa): 455'-3"
Beam: 62'
Draft: 28'
Displacement: 15,200 (fl) tons
(The listed dimensions are as built, but it should be noted that draft, displacement, and tonnages were subject to alteration over time as well as variations in measurement.)

Dates of Construction: Keel laying: 22 March 1945
Launching: 17 May 1945
Delivery: 11 June 1945

Designer: U.S. Maritime Commission

Builder: California Shipbuilding Corporation, Wilmington, California

Present Owner: U.S. Maritime Administration

Disposition: Inactive—National Defense Reserve Fleet
Postscript: As of 2010, the ship was being prepared for scrapping by ESCO Marine in Brownsville, Texas.

Significance: The *Winthrop Victory* is significant as an example of the *Victory* class, a new class of cargo ships that entered service during World War II. These fast, long-range vessels supplanted the *Liberty* ships and were notable as the first of a new generation of general cargo ships.

Historian: Brian Clayton, fall 2007

**Project
Information:**

This project is part of the Historic American Engineering Record (HAER), a long-range program to document historically significant engineering and industrial works in the United States. The Heritage Documentation Programs of the National Park Service, U.S. Department of the Interior, administers the HAER program.

The project was prepared under the direction of Todd Croteau (HAER Maritime Program Coordinator). Ashley T. Walker (HAER) scanned and reformatted the historic vessel drawings. Brian Grogan (Photography + Preservation Associates) produced the large-format photographs. Special thanks to Erhard Koehler (U.S. Maritime Administration) whose help and assistance greatly benefited this project.

See HAER No. TX-110, *Maritime Victory* for an example of a VC2-S-AP2 ship converted to a troopship.

BACKGROUND

Critical to the Allied success in World War II was the U.S. Maritime Commission, which helped develop and construct a variety of military and civilian ships for use during the war, of which the *Victory* class was one example. The *Victory* ships, like the *Winthrop Victory*, primarily served as point-to-point cargo vessels, but their design also allowed them to be utilized in different configurations, such as transports. The *Victory* cargo vessel was one small component in the war effort, but it proved critical in moving personnel, supplies, and equipment to the warfront and during peacetime.¹

Prior to the establishment of the U.S. Maritime Commission, other government agencies had been tasked with adding ships to the Merchant Marine. After 1918, the majority of the ships in the Merchant Marine came from the mobilization endeavor to support American troops in World War I. The U.S. Shipping Board had approved the construction of 470 ships to support the war effort. Between 1918 and 1922, the board added another 1,300 ships to the Merchant Marine, which became the backbone of the fleet. In the mid-1920s, U.S. shipping companies were robust, but the U.S. stock market crash in 1929 was a major setback to the maritime industry. During the Great Depression, many steamship companies suffered because they were unable to replace or update their aging ships—over 90 percent of the fleet was over twenty years old and had an average speed of between 10 and 11 knots.²

In the mid-1930s, the government intervened with new legislation to aid the beleaguered maritime industry. President Franklin D. Roosevelt's New Deal economic policy eventually helped revive the Merchant Marine when Congress passed the Merchant Marine Act of 1936. The legislation established the U.S. Maritime Commission as the successor to the U.S. Shipping Board. The act also infused new capital and ideas for rebuilding the fleet. By 1937, the Maritime Commission had planned a long-range construction program to build 500 ships that were both contemporary and economical over a ten-year period. In 1939, the Maritime Commission determined that the production quota of fifty ships per year was too low and doubled it. The success of the German U-boat campaign at this time against English shipping had begun to alarm United States steamship companies who often traded with England and France. Fearing that Germany might target U.S. ships, the Maritime Commission accordingly raised the shipping quota again in August 1940 to 200 ships per year.³

DESIGN OF VICTORY CLASS

On 3 January 1942, President Roosevelt declared that the United States would build a standard 11-knot ship called the *Liberty* in mass quantity and under the guidance of the Maritime Commission as part of an Emergency Program. While the *Liberty* ships were not particularly aesthetically pleasing nor were they speedy, their mass production helped offset the German U-

¹ L.A. Sawyer and W.H. Mitchell, *Victory Ships and Tankers: The History of the 'Victory' Type Cargo Ships and of the Tankers Built in the United States of America during World War II* (Cambridge, MD: Cornell Maritime Press, Inc., 1974), pp. 15-17, 23-24.

² Brian J. Cudahy, *Box Boats: How Container Ships Changed the World* (New York: Fordham University Press, 2006), pp. 2-3; Sawyer and Mitchell, *Victory Ships and Tankers*, p. 15.

³ Cudahy, *Box Boats*, p. 3; Sawyer and Mitchell, *Victory Ships and Tankers*, pp. 15-16.

boat successes in the Atlantic campaign during World War II. By the end of the war, the Maritime Commission had produced over 2,700 *Liberty* ships, but a second-generation cargo ship soon supplanted the *Liberty* when the U.S. Maritime Commission proposed the construction of a new class of cargo vessels in 1943. The design was based on a British fast cargo ship dating to 1942 that could operate outside the convoy parameters. U.S. naval architects drew the plans for this new ship with a basic design of 445' long, 63' abeam, and a 28' draft. There were two key requirements for this new class: the deadweight had to equal that of a *Liberty* ship and it had to have a maximum speed of 15 knots. Bethlehem Steel developed the arrangement plans while the Maritime Commission focused on the stability calculations and other considerations. Early on, the Maritime Commission realized that some shipyards designated to build the new ships did not have slips to accommodate a 63'-beam ship so the design was consequently altered to a 62' beam.⁴

The Maritime Commission approved the new drawings for the fast cargo ship in March 1943 and scheduled production to begin in April. The commission designated the new ships as the *Victory* class (VC2-S-AP2). In addition to speed, the Maritime Commission considered the postwar disposal of the ships. American planners thought the *Victory* ship design would appeal to ship owners and that steamship companies would purchase the vessels at the conclusion of hostilities. The Maritime Commission wanted to begin production quickly, but disagreements with the War Production Board stalled construction until the end of 1943.⁵

CONSTRUCTION

In March 1944, the Maritime Commission designated six shipyards to construct the *Victory* ships. Shipyards were able to quickly construct the ships because of the use of production line methods (prefabricated parts, assembly, construction of sections, and welding) and because of the standardized design. U.S. shipyards produced a total of 272 VC2-S-AP2 ships, including the *Winthrop Victory*.⁶

The California Shipbuilding Company (Calship) in Los Angeles was one of the yards charged with constructing the *Victory* ships. Henry J. Kaiser, part owner of Todd Shipbuilding in the Seattle-Tacoma Shipbuilding Corporation had invested in the company but his firm did not manage it; instead, a subsidiary company ran the terminal. Calship was built on the marshy side of Terminal Island; as a result, before workers could lay a foundation, they had to pound 57,000 pilings into the marsh and fill in the rest with soil. The original project called for the construction of eight ways and six outfitting docks, but the Maritime Commission authorized the expansion of the yard to fourteen ways and ten outfitting docks to meet higher production quotas. The anticipated cost of the Calship facility in 1941 was \$10,004,000, which had risen to an

⁴ Sawyer and Mitchell, *Victory Ships and Tankers*, pp. 16-18; Frederic C. Lane, *Ships for Victory: A History of Shipbuilding under the U.S. Maritime Commission in World War II* (Baltimore: Johns Hopkins Press, 1951), pp. 574-580.

⁵ Sawyer and Mitchell, *Victory Ships and Tankers*, p. 32; Lane, *Ships for Victory*, pp. 586-607. The other type of *Victory* ship was the VC2-S-AP3, which was 1 knot faster and consequently had higher-powered machinery. However, the hulls were the same.

⁶ Lane, *Ships for Victory*, pp. 212-213; Sawyer and Mitchell, *Victory Ships and Tankers*, pp. 32, 37.

estimated at \$26,928,000 in 1944. At the height of production, the shipyard employed over 40,000 men and women. Calship completed the *Winthrop Victory* on 11 June 1945. The total production time was eighty-one days, of which fifty-one days were on the way and twenty-five were spent fitting out.⁷

DESCRIPTION

The VC2-S-AP2 had a fine rake and cruiser stern to promote a more streamlined flow of water, which consequently allowed the ship to achieve higher speeds. The ships measured 455'-3" in overall length with a 62' beam. Frames spaced 36" apart strengthened the hull and improved its flexibility, addressing the problem of stress fractures that plagued the *Liberty* ships. The main difference between the *Victory* and the *Liberty* ships was the *Victory*'s ability to carry more deadweight cargo. The upper deck could carry 335 pounds per square foot while the second deck could carry between 540 and 620 pounds per square foot. The third deck carried 1,650 pounds per square foot. Since "one of the most important attributes of the *Victory* ship was its ability to carry a good deadweight of cargo," seven divisional bulkheads created five holds, along with fore and aft peak tanks and machinery space.⁸ The No. 1 hold measured 57'-6" x 24'-11" with a 81,715 cubic foot grain capacity (reduced somewhat by the fact that there was a double bottom), while the No. 2 hold was 45' x 23'-11" with a grain capacity of 89,370 cubic foot. The No. 3 hold had the largest grain capacity at 156,000 cubic foot and measured 78' x 35'-11". Finally, the No. 4 hold had 113,080 cubic foot grain capacity and measured 81' x 35'-11", and the No. 5 hold had the smallest capacity at 75' x 23'-11" and 81,575 cubic foot. Each hold was equipped with a hatch. There was 3,129 tons of ballast water in the forepeak, deep tanks, and the after peak to balance and trim the varying loads between ports.⁹

The ship was equipped with masts and kingposts as well as winches and booms on the main deck to service the cargo holds. Each hold had two 5-ton booms, while hold 3 had an additional 50-ton boom. There was another 30-ton boom in hold 4. Ten single-speed 50-hp electric winches serviced the 5-ton booms and four two-speed 50-hp winches assisted the 30-ton and 50-ton booms. The anchor windlass had a 60-hp electric motor with two horizontal drums, and one 35-hp vertical deck capstan was located on the fantail.

The *Winthrop Victory* contained an Allis-Chalmers cross compound steam turbine with Falk double reduction gears to allow the ship to reach higher speeds and longer ranges. The engine rating was 6,000 horsepower. It turned a 19' propeller 90 revolutions per minute (rpm) at a cruising speed of 15-½ knots and 103 rpm at a flank speed of 16-½ knots. The cruising range was 25,000 nautical miles, and the vessel could carry 2,883 tons of fuel oil. The two Babcock and Wilcox boilers were oil fired and used forced draft water tubing with super heaters and

⁷ "California Shipbuilding Corporation," available at <http://library.csun.edu/Collections/SCA/UAC/CALSHIP>, accessed 18 September 2007; Lane, *Ships for Victory*, pp. 51, 54-55, 59, 472.

⁸ Sawyer and Mitchell, *Victory Ships and Tankers*, p. 37.

⁹ The description is based on Sawyer and Mitchell, *Victory Ships and Tankers*, pp. 18-19, 32, 37-38; "VC-S-AP2 Type (Victory Ships)" listed in "Maritime Commission Ship Types during World War II," available at <http://www.ibiblio.org/hyperwar/USN/ships/ships-mc.html>, accessed 25 September 2007.

economizers. The boiler's working pressure was 525 pounds per square inch at 750°F. Auxiliary power came from two industrial diesel generators on board.

The Maritime Commission armored each *Victory* ship with three types of guns. On the bow of the *Winthrop Victory* was a single 3" gun, the boat deck had eight 20-millimeter anti-aircraft guns, and there was one 5"/38-caliber dual-purpose gun on the stern. The ship carried twenty-eight gunners who lived in the amidships deck house and the aft deckhouse, enabling them to better access their positions around the ship.

Steering and navigation took place in the amidships house. The officer's quarters were in the amidships cabin deck and below on the boat deck were the engineer's quarters, as well as the wardroom and officer's mess. On the main deck were the crew's quarters, the galley, and their mess. Below on the second deck were the dry and refrigerated storerooms, with a general store capacity of around 11,000 cubic feet and refrigerated storage capacity of around 4,600 cubic feet. The forward room contained the wheelhouse, while the chart room was just aft. The ship's wheel was connected to the Stetson-Ross hydraulic steering gear in the aft compartment on the second deck.

Additional storage space was located on the main deck in the forecastle and in the lazarette. Crew used the rooms in the forecastle for ship supplies, such as a paint locker and stowage of extra lines and ammunition lockers. In the aft end of the ship were more storerooms for extra line and ammunition. There were basic carpenter shops in the forecastle and in the aft end of the ship.

OPERATIONAL HISTORY

The *Winthrop Victory* was delivered to the War Shipping Administration on 11 June 1945. At the end of June, the ship left the West Coast for the Pacific and worked its way up the island chains to Manila on 18 July. After the Japanese surrender on 15 August 1945, the *Winthrop Victory* sailed into Tokyo Bay on 10 September. After the war, Marine Transportation ran the ship and sailed it westward, making ports of call in Calcutta, Port Said, and Gibraltar, before heading back to New York. On the East Coast, the ship made various ports of call and headed to Europe and back to New York in the summer of 1946. The *Winthrop Victory* returned to the National Defense Reserve Fleet in 1947. The ship is currently in Suisun Bay, California, awaiting disposal.¹⁰

CONCLUSION

The *Winthrop Victory* had an economical design and was a versatile ship, as were all the *Victory* ships, which allowed the Maritime Commission to utilize these vessels in different configurations as cargo ships and transports. The long range and high speed of the *Victory* class, as well as its efficient design, proved successful during the war and afterwards when the ships were converted into commercial ships or continued as military transports. The Military Sealift

¹⁰ "Ship Movement Cards-Wil-Zyr," 1945-46, in Box 435, "Records Relating to Merchant Shipping and Convoys," Record Group 38, National Archives and Records Administration—College Park, Maryland.

Command reactivated some *Victory* ships to carry cargo and supplies during Operation Desert Shield and Operation Desert Storm, for example. In addition to the usefulness of the class, the ships were also significant as prototypes for later improved ship designs by the Maritime Commission. Although the *Victory* class has nearly disappeared, three have been preserved as museums: *American Victory*, *Lane Victory*, and *Red Oak Victory*.¹¹

¹¹ Salvatore R. Mercogliano, “‘Operations Other Than War,’ for Military Sea Transportation Service and Military Sealift Command,” available at <http://www.usmm.org/msts/ootw.html>, accessed 7 November 2007.

BIBLIOGRAPHY

Books

Cudahy, Brian J. *Box Boats: How Container Ships Changed the World*. New York: Fordham University Press, 2006.

Lane, Frederic C. *Ships for Victory: A History of Shipbuilding under the U.S. Maritime Commission in World War II*. Baltimore: Johns Hopkins Press, 1951.

Sawyer, L.A. and W.H. Mitchell. *Victory Ships and Tankers: The History of the 'Victory' Type Cargo Ships and of the Tankers Built in the United States of America during World War II*. Cambridge: Cornell Maritime Press, 1974.

Documents

"Ship Movement Cards—Wil-Zyr." 1945-46. Box 435, "Records Relating to Merchant Shipping and Convoys," Record Group 438, National Archives and Records Administration—College Park, Maryland.

Internet Material

"California Shipbuilding Corporation." Available at <http://library.csun.edu/Collections/SCA/UAC/CALSHIP>, accessed 2007.

"Maritime Commission Ship Types during World War II." Available at <http://www.ibiblio.org/hyperwar/USN/ships/ships-mc.html>, accessed 2007.

Mercogliano, Salvatore R. "Operations Other than War," for Military Sea Transportation Service and Military Sealift Command." Available at <http://www.usmm.org/msts/ootw.html>, accessed 2007.

HISTORIC AMERICAN ENGINEERING RECORD

INDEX TO PHOTOGRAPHS

WINTHROP VICTORY

HAER CA-345

(V-74)

Suisun Bay Reserve Fleet

Benicia vicinity

Solano County

California

INDEX TO BLACK AND WHITE PHOTOGRAPHS

Brian Grogan, photographer, 2007

- | | |
|-----------|--|
| CA-345-1 | Starboard side view of superstructure, looking forward. |
| CA-345-2 | Starboard side view of forward deck from bridge wing. |
| CA-345-3 | Port side view of forward deck from bridge wing. |
| CA-345-4 | Detail view of port side of forward deck. |
| CA-345-5 | Base of forward mast. |
| CA-345-6 | Port side view of forward deck, looking aft. |
| CA-345-7 | Bow deck, anchor chains, and winches, looking aft. |
| CA-345-8 | Rear deck and mast, looking aft. |
| CA-345-9 | Hatch on rear deck and superstructure, starboard side. View looking forward. |
| CA-345-10 | Starboard side view of rear deck and superstructure, looking forward. |
| CA-345-11 | Stern, starboard side. |
| CA-345-12 | Stern and propellor. |

HISTORIC AMERICAN ENGINEERING RECORD
SEE INDEX TO PHOTOGRAPHS FOR CAPTION

HAER No. CA-345-1



HISTORIC AMERICAN ENGINEERING RECORD
SEE INDEX TO PHOTOGRAPHS FOR CAPTION

HAER No. CA-345-2



HISTORIC AMERICAN ENGINEERING RECORD
SEE INDEX TO PHOTOGRAPHS FOR CAPTION

HAER No. CA-345-3



HISTORIC AMERICAN ENGINEERING RECORD
SEE INDEX TO PHOTOGRAPHS FOR CAPTION

HAER No. CA-345-4



HISTORIC AMERICAN ENGINEERING RECORD
SEE INDEX TO PHOTOGRAPHS FOR CAPTION

HAER No. CA-345-5



HISTORIC AMERICAN ENGINEERING RECORD
SEE INDEX TO PHOTOGRAPHS FOR CAPTION

HAER No. CA-345-6



HISTORIC AMERICAN ENGINEERING RECORD
SEE INDEX TO PHOTOGRAPHS FOR CAPTION

HAER No. CA-345-7

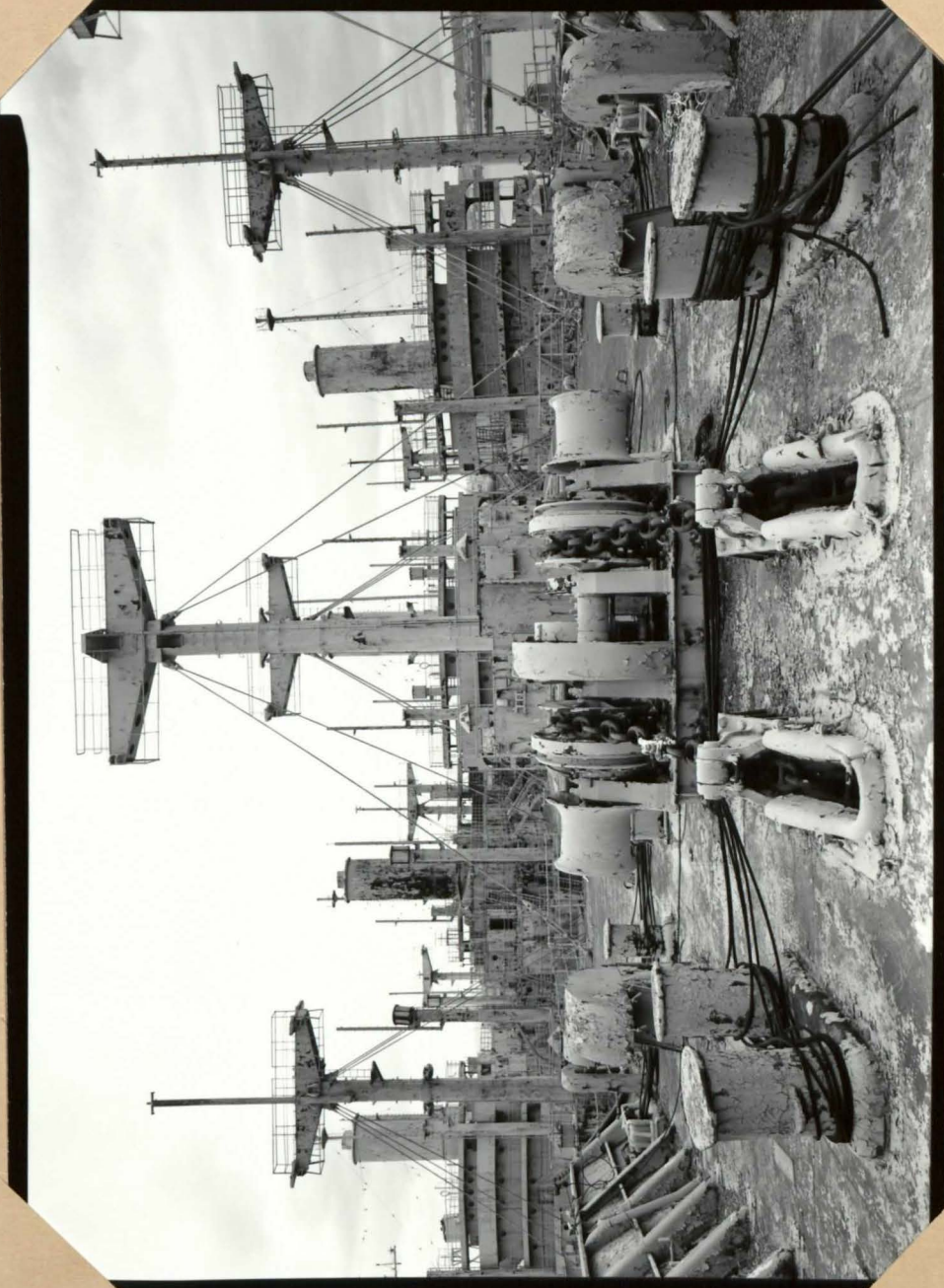

HISTORIC AMERICAN ENGINEERING RECORD
SEE INDEX TO PHOTOGRAPHS FOR CAPTION

HAER No. CA-345-8



HISTORIC AMERICAN ENGINEERING RECORD
SEE INDEX TO PHOTOGRAPHS FOR CAPTION

HAER No. CA-345-9

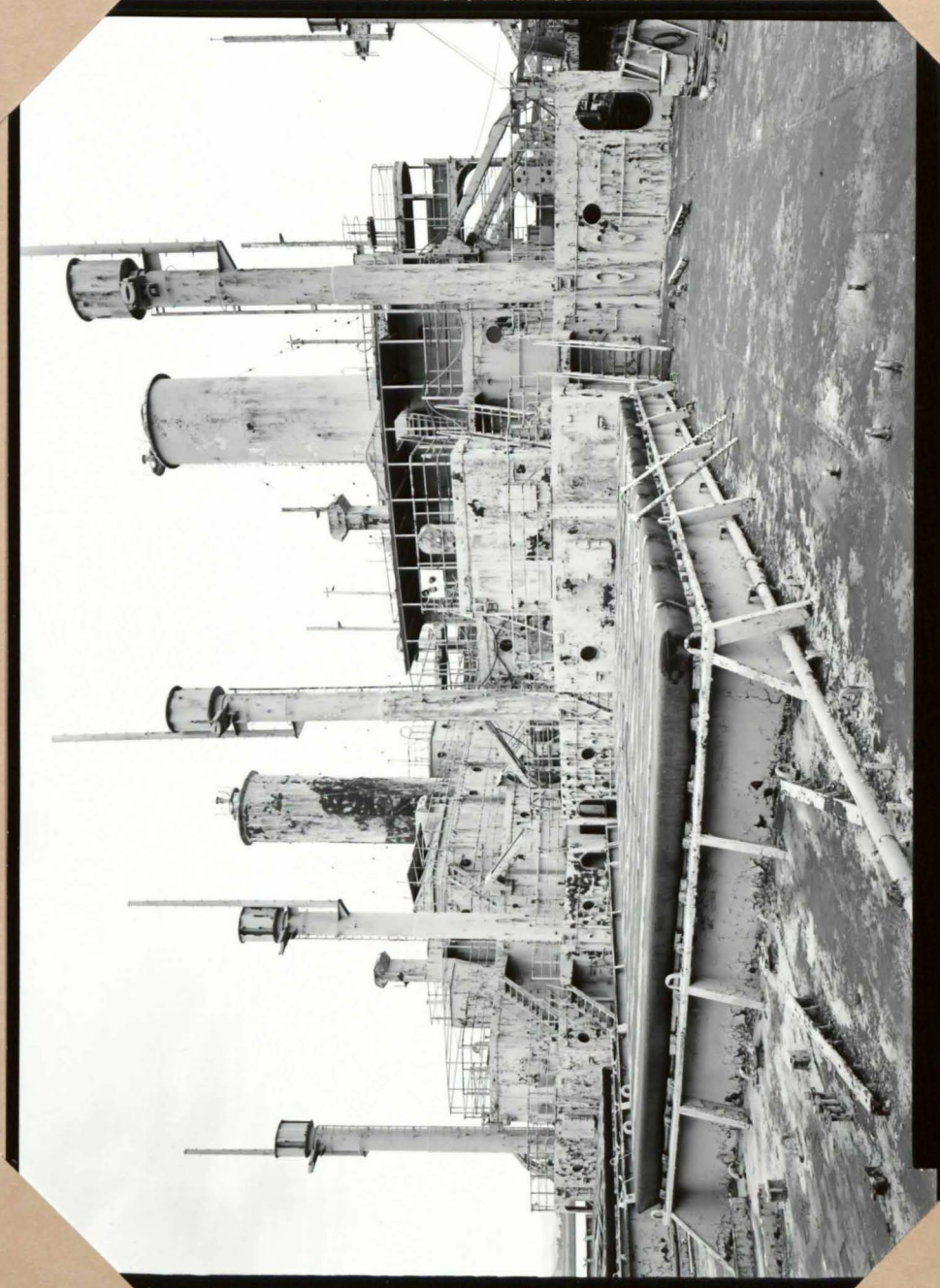

HISTORIC AMERICAN ENGINEERING RECORD
SEE INDEX TO PHOTOGRAPHS FOR CAPTION

HAER No. CA-345-10



HISTORIC AMERICAN ENGINEERING RECORD
SEE INDEX TO PHOTOGRAPHS FOR CAPTION

HAER No. CA-345-11



HISTORIC AMERICAN ENGINEERING RECORD
SEE INDEX TO PHOTOGRAPHS FOR CAPTION

HAER No. CA-345-12



Winthrop Victory

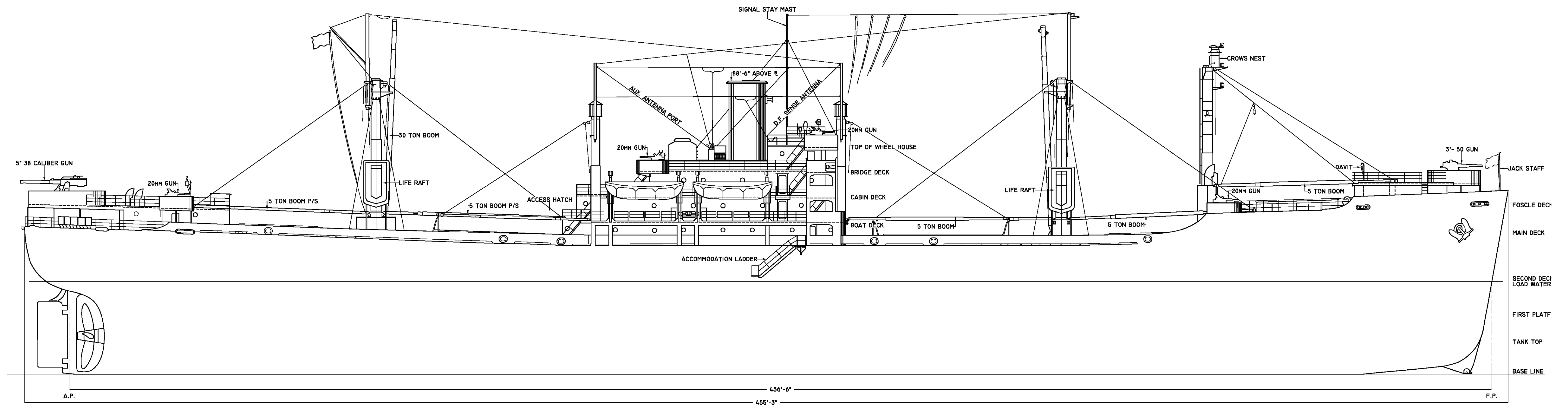

OUTBOARD PROFILE

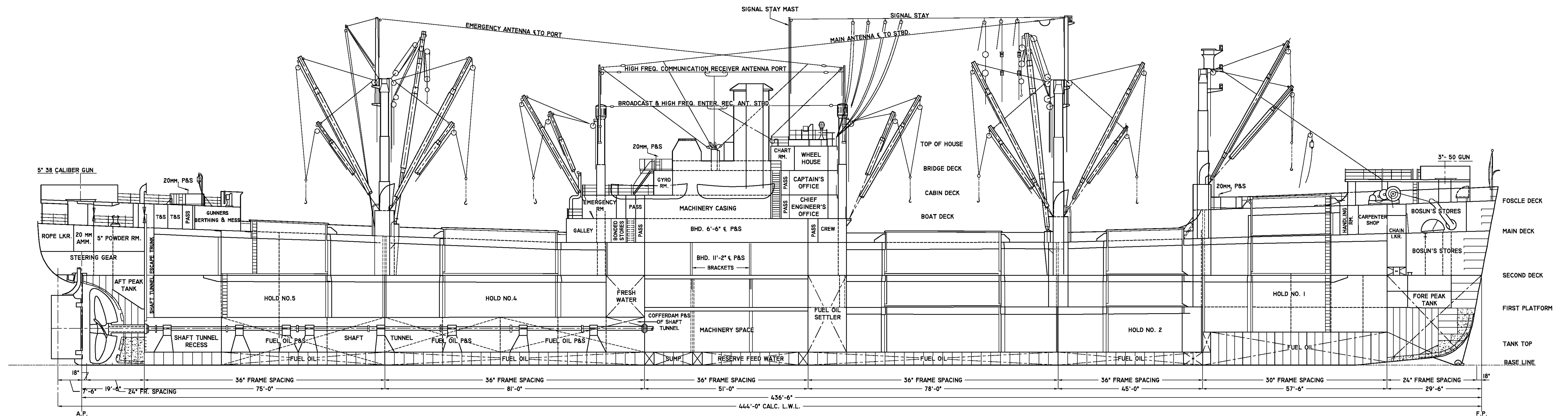

INBOARD PROFILE

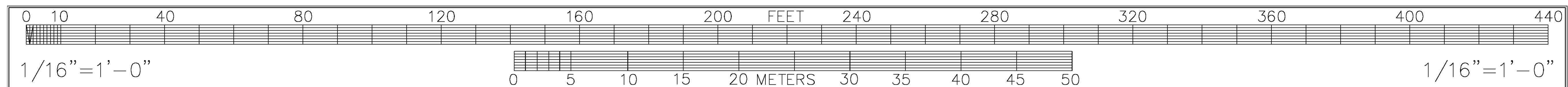

SCANNED FROM HISTORIC DRAWINGS AND REFORMATTED BY: ASHLEY T. WALKER, 2010
 HAER MARITIME RECORDING PROGRAM
 NATIONAL PARK SERVICE
 UNITED STATES DEPARTMENT OF THE INTERIOR
 BENICIA VICINITY
 WINTHROP VICTORY (V77)
 SUISUN BAY RESERVE FLEET
 SOLANO COUNTY
 CALIFORNIA 2 OF 6
 HISTORIC AMERICAN ENGINEERING RECORD
 INDEX NUMBER CA-345

IF INTRODUCED, PLEASE CREDIT THE HISTORIC AMERICAN ENGINEERING RECORD, NATIONAL PARK SERVICE, NAME OF DEDICATOR, DATE OF DONATION

Winthrop Victory

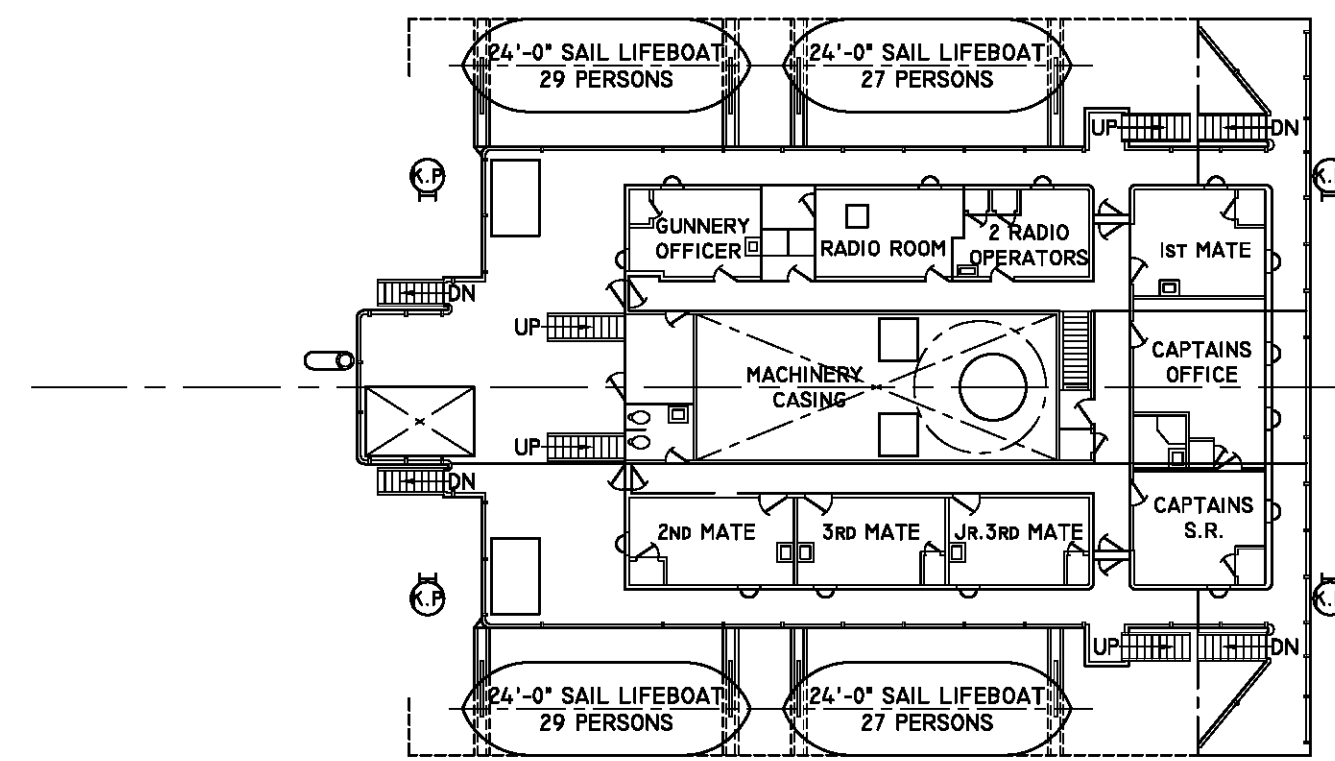

CABIN DECK

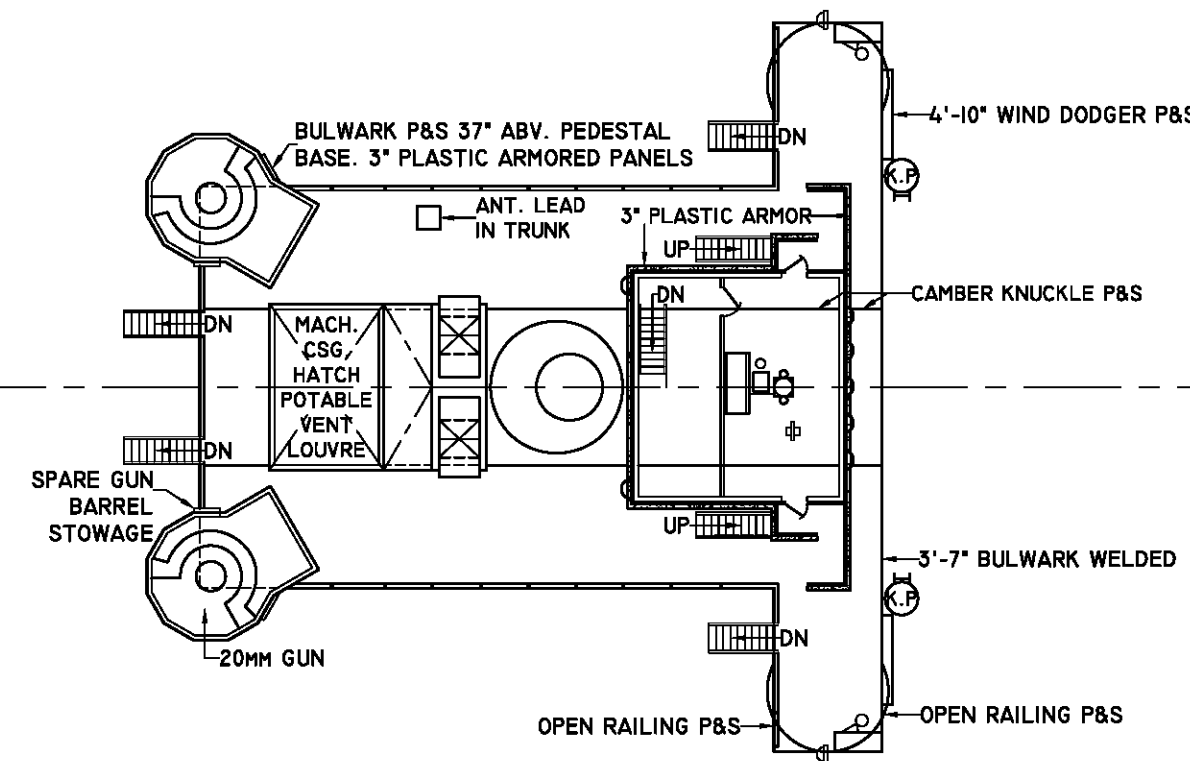

BRIDGE DECK

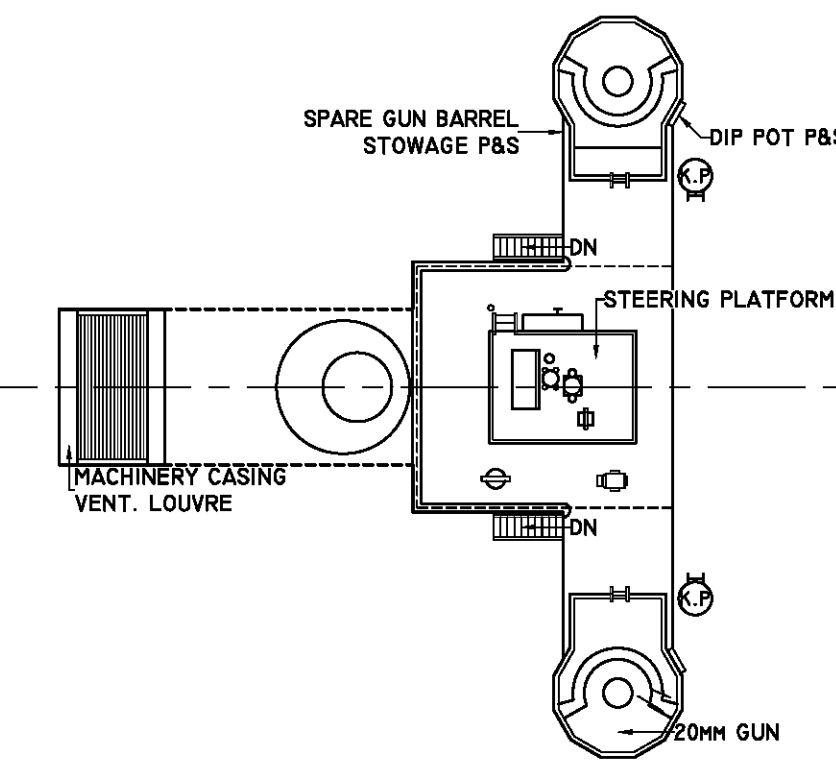

TOP OF WHEEL HOUSE

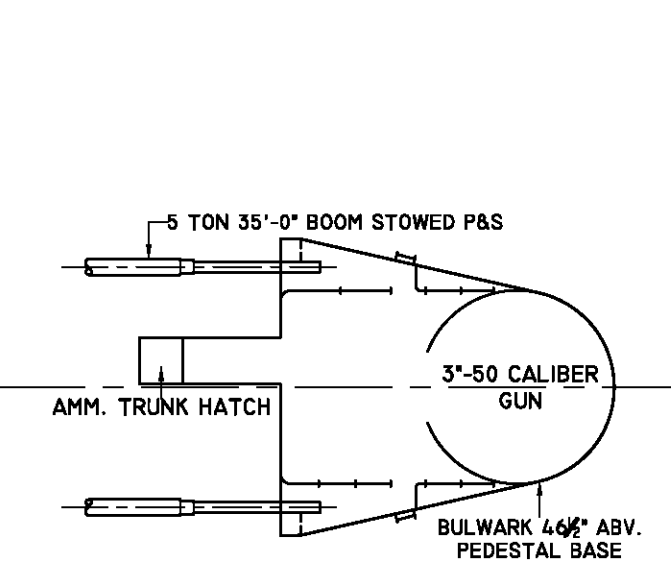

FORWARD GUN PLATFORM

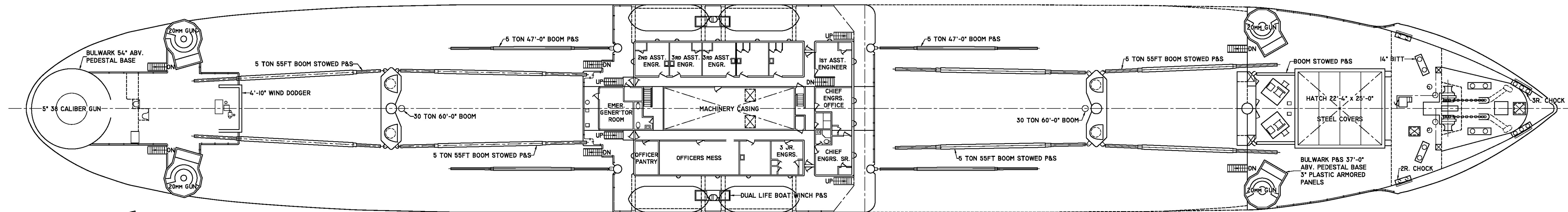

FORECASTLE DECK

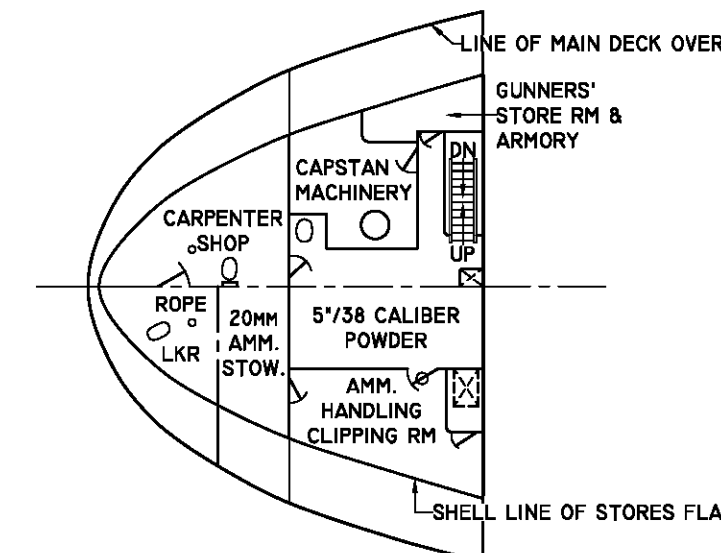

STORES FLAT AFT.

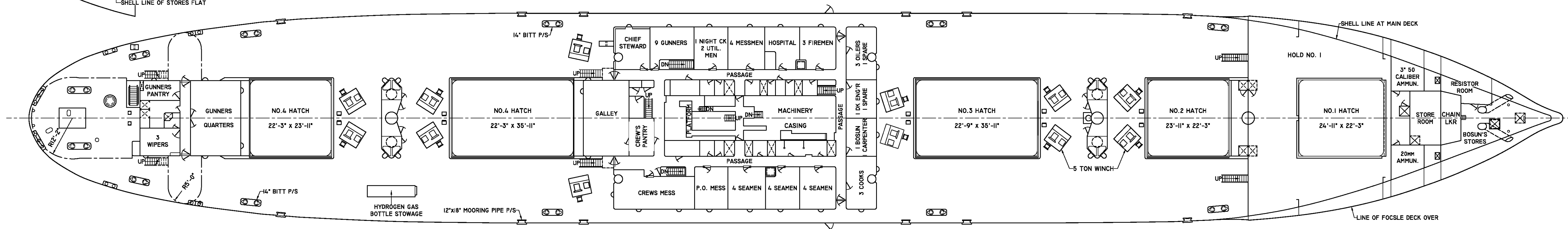

MAIN DECK

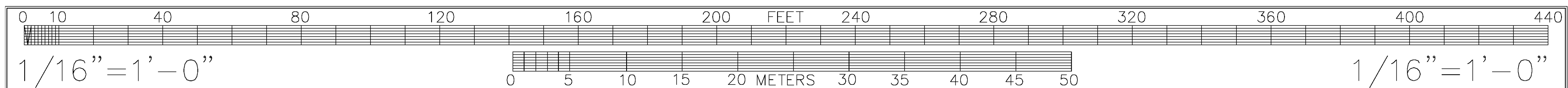

LIBRARY OF CONGRESS
HISTORIC AMERICAN
ENGINEERING RECORD
INDEX NUMBER
CA-345

SHEET 3 OF 6
CALIFORNIA

WINTHROP VICTORY (V77)
SUISUN BAY RESERVE FLEET
SOLANO COUNTY

BENICIA VICINITY

SCANNED FROM HISTORIC DRAWINGS AND REFORMATTED BY: ASHLEY T. WALKER, 2010
NAVAL MARITIME
RECORDING PROGRAM
NATIONAL PARK SERVICE
UNITED STATES DEPARTMENT OF THE INTERIOR

REPRODUCED, PLEASE CREDIT THE HISTORIC AMERICAN ENGINEERING RECORD, NATIONAL PARK SERVICE, NAME OF DEDICATOR, DATE OF DRAWING

Winthrop Victory

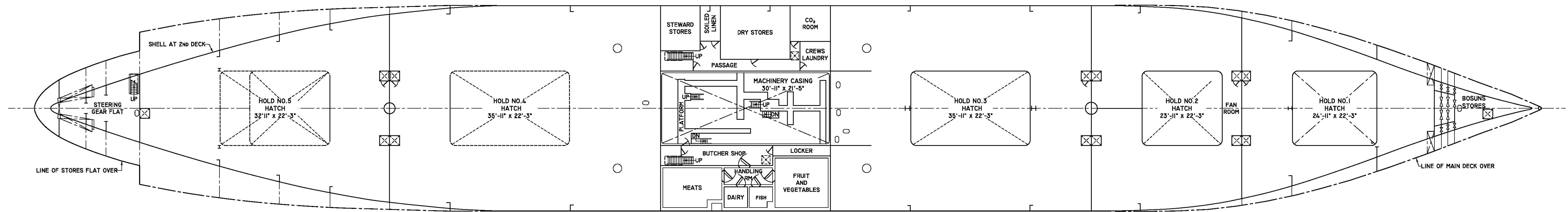

SECOND DECK

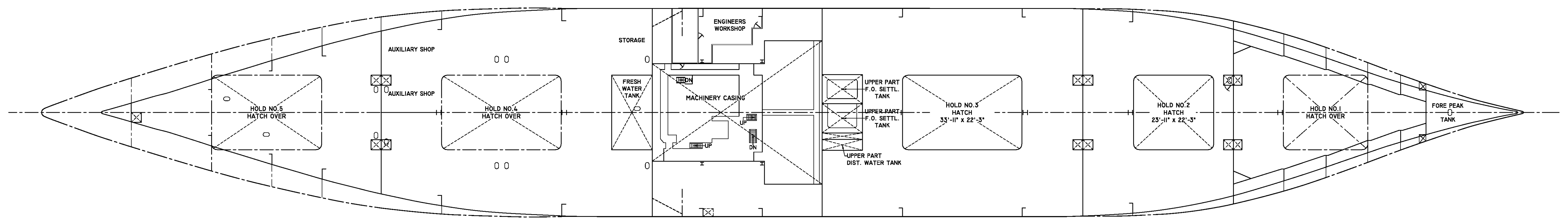

FIRST PLATFORM

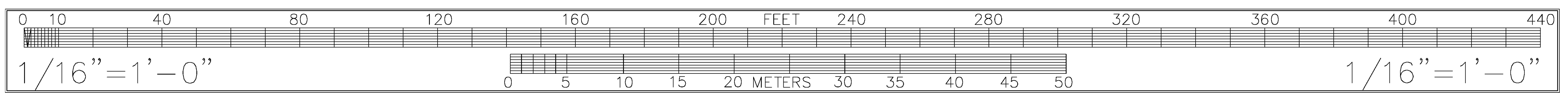

SCANNED FROM HISTORIC DRAWINGS AND REFORMATTED BY: ASHLEY T. WALKER, 2010
 NAVAL MARITIME RECORDING PROGRAM
 NATIONAL PARK SERVICE
 UNITED STATES DEPARTMENT OF THE INTERIOR
 BENICIA VICINITY
 WINTHROP VICTORY (V77)
 SUISUN BAY RESERVE FLEET
 SOLANO COUNTY
 CALIFORNIA 4 OF 6
 SHEET
 HISTORIC AMERICAN ENGINEERING RECORD
 CA-345
 INDEX NUMBER
 LIBRARY OF CONGRESS

IF REPRODUCED, PLEASE CREDIT THE HISTORIC AMERICAN ENGINEERING RECORD, NATIONAL PARK SERVICE, NAME OF DEDICATOR, DATE OF DRAWING

Winthrop Victory

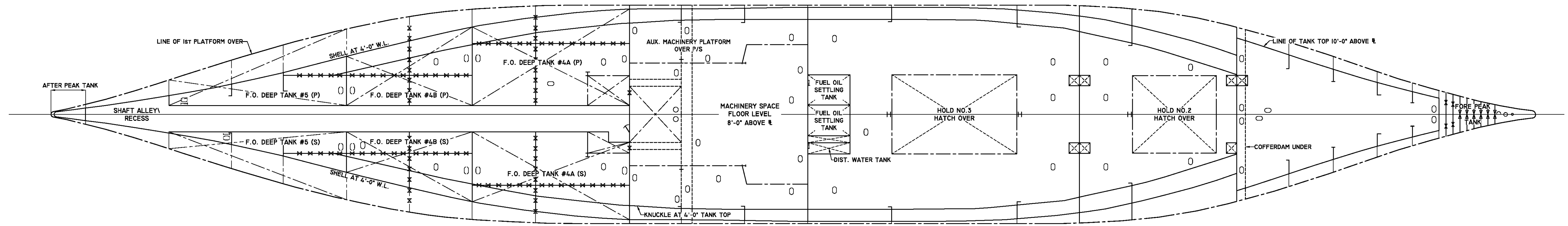

HOLD

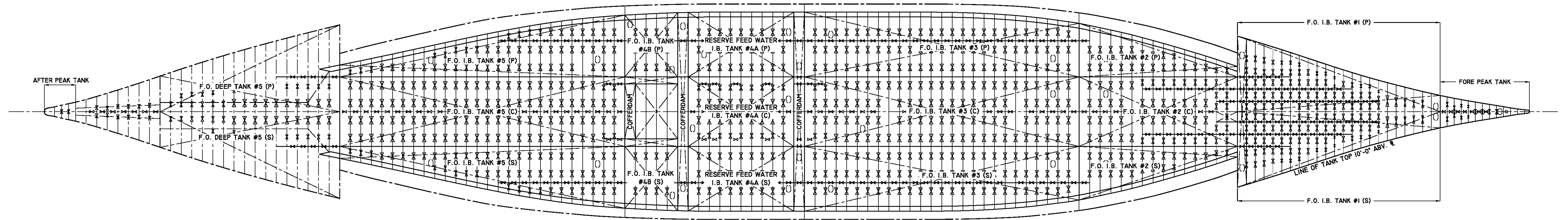

INNER BOTTOM

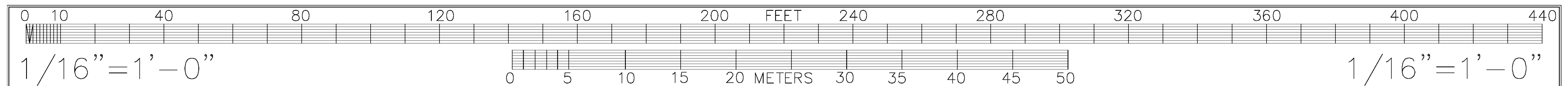

Winthrop Victory

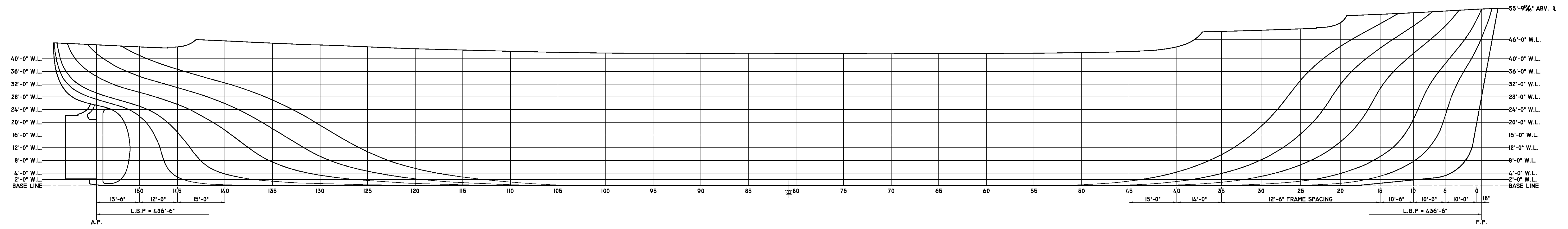

SHEER PLAN

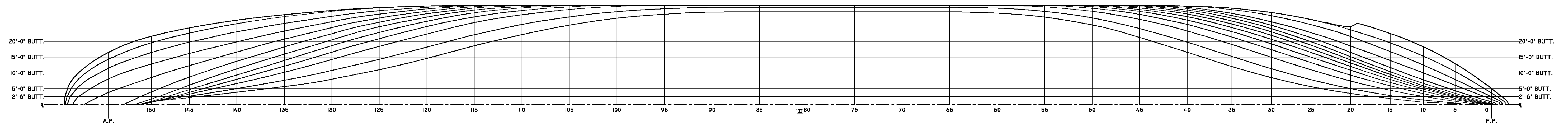

HALF-BREADTH PLAN

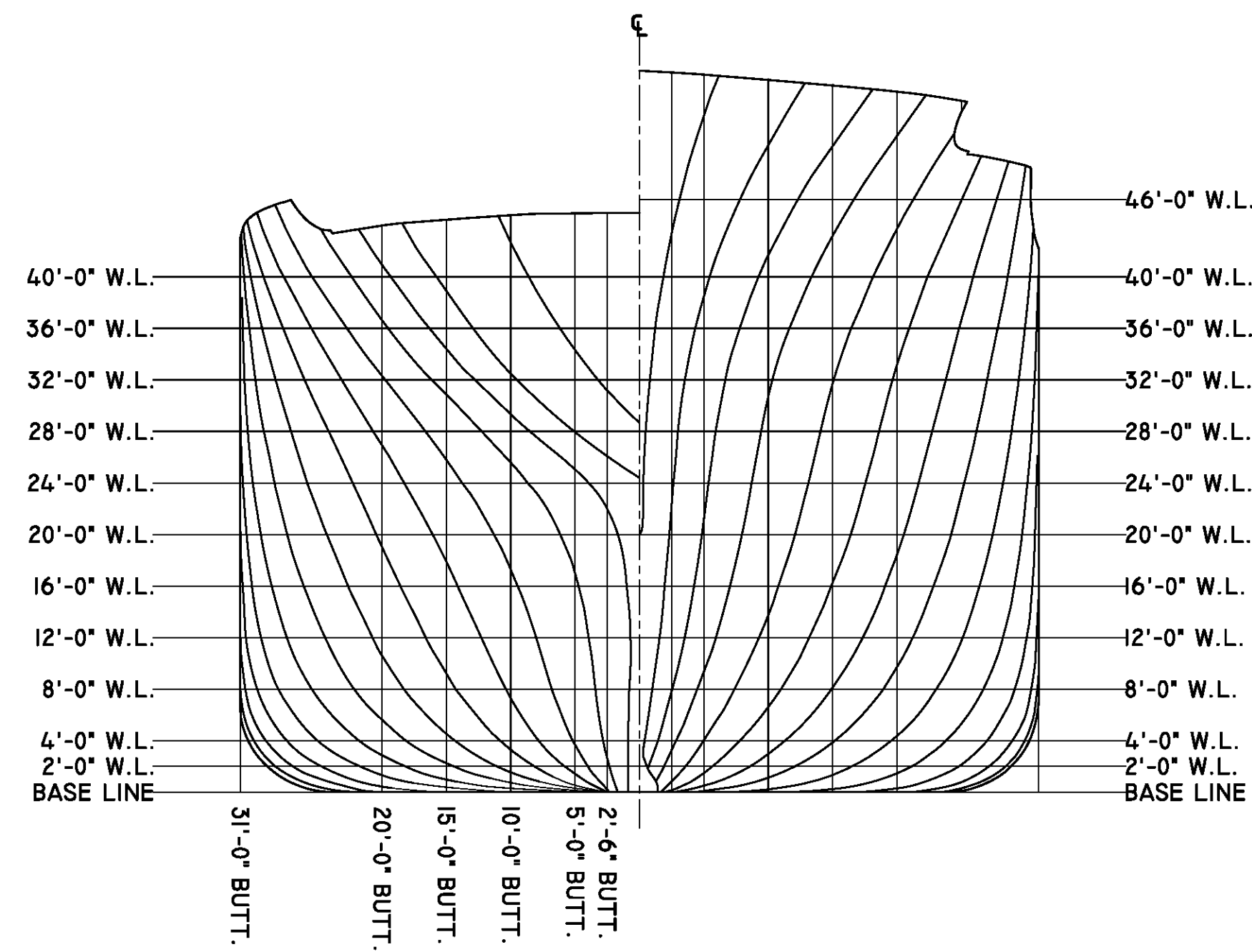
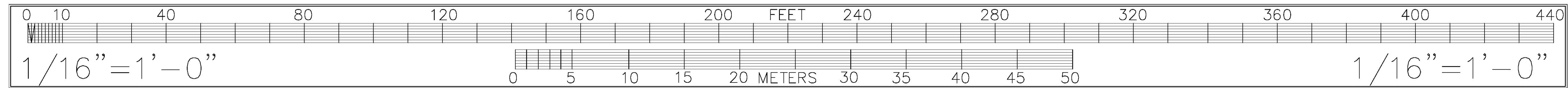

BODY PLAN

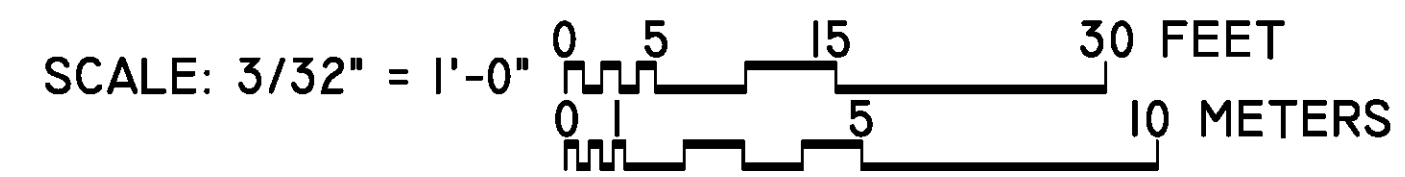

SCANNED FROM HISTORIC DRAWINGS AND REFORMATTED BY: ASHLEYBYT, WMAIKER, Z2000
 HAER MARITIME RECORDING PROGRAM
 NATIONAL PARK SERVICE
 UNITED STATES DEPARTMENT OF THE INTERIOR

WINTHROP VICTORY (V77)
 SUISUN BAY RESERVE FLEET
 SOLANO COUNTY

BENICIA VICINITY

HISTORIC AMERICAN ENGINEERING RECORD
 SHEET 6 OF 6
 INDEX NUMBER CA-345

IF REPRODUCED, PLEASE CREDIT THE HISTORIC AMERICAN ENGINEERING RECORD, NATIONAL PARK SERVICE, NAME OF DELINEATOR, DATE OF DRAWING