



USS Gage

Design Type: VC2-S-AP5
Official Number: APA-168



GENERAL CHARACTERISTICS

BUILDER: OREGON SHIPBUILDING CORP.
BUILT: 1944
LOA: 455'-0"
BEAM: 62'-0"
DRAFT: 24'-0"
SPEED: 18 KNOTS
PROPULSION: OIL FIRED STEAM
 TURBINE,
 SINGLE SHAFT
DISPLACEMENT: 7,190 TONS (LIGHTSHIP)
 10,680 TONS (FULL)
COMPLEMENT: 56 OFFICERS
 480 ENLISTED
ARMAMENT: 1 5"/38 GUN
 1 40MM QUAD MOUNT
 4 40MM TWIN MOUNTS
 10 20MM SINGLE
 MOUNTS



THE *USS GAGE* AT ANCHOR IN SAN FRANCISCO BAY, CIRCA 1946 PHOTO# NH98721

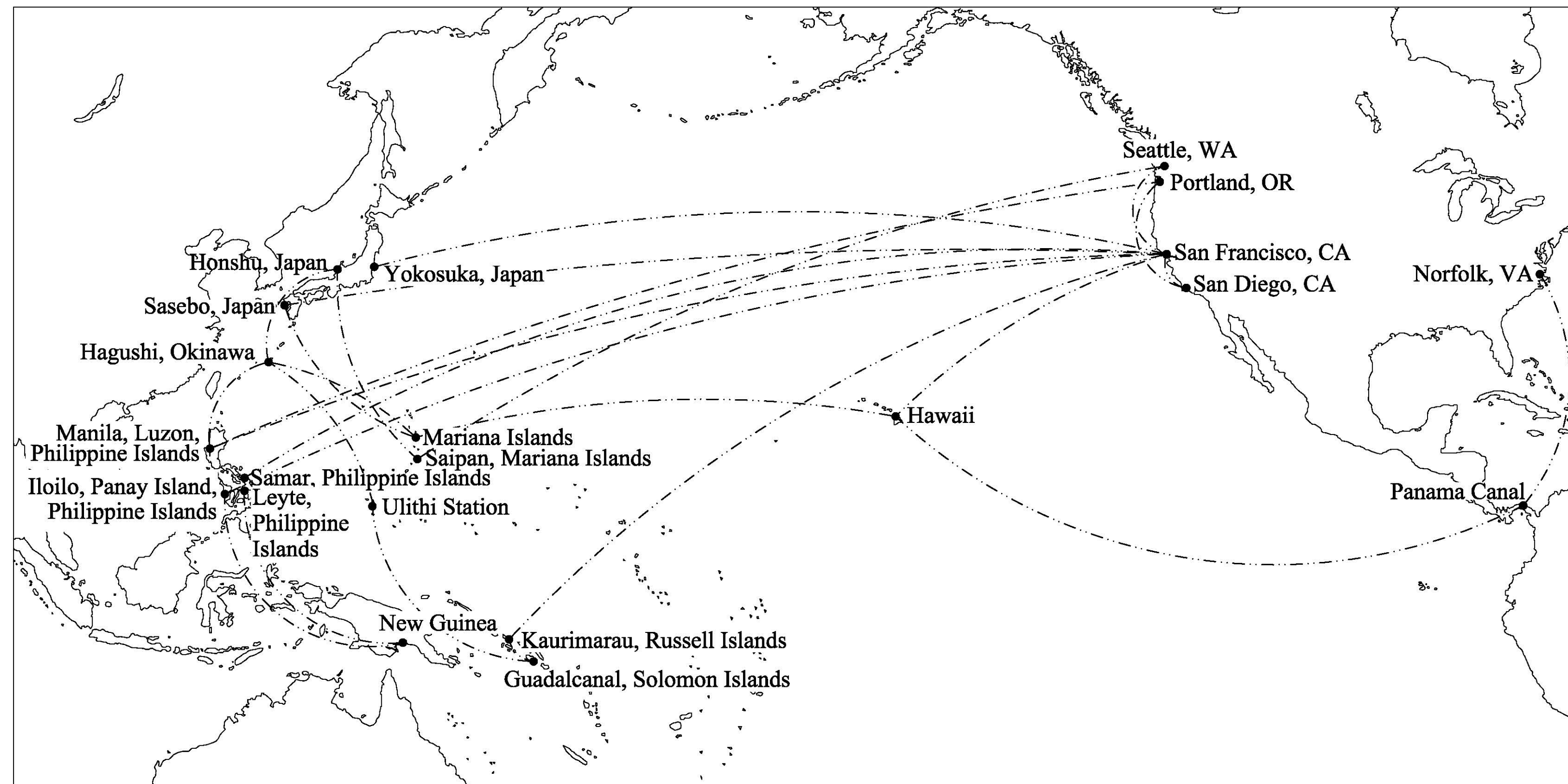

NOTE: COURSES DEPICTED ON MAP ARE ABSTRACTED TO CONNECT LOCATIONS. THEY DO NOT REPRESENT THE EXACT COURSES TRAVELED.

DURING THE CLOSING YEARS OF WORLD WAR II, MILITARY PLANNERS REQUESTED THAT THE MARITIME COMMISSION CONSTRUCT A NEW CLASS OF ATTACK TRANSPORTS. DESIGNERS UTILIZED THE NEW *VICTORY* CLASS AND CONVERTED IT INTO A TROOP TRANSPORT FOR THE U.S. NAVY CALLED THE *HASKELL* CLASS, DESIGNATED AS VC2-S-AP5. THE MARITIME COMMISSION CONSTRUCTED 117 ATTACK TRANSPORTS DURING THE WAR, AND THE *GAGE* IS THE SOLE REMAINING SHIP AFLOAT IN ITS ORIGINAL CONFIGURATION.

THIS RECORDING PROJECT WAS COSPONSORED BY THE HISTORIC AMERICAN ENGINEERING RECORD (HAER) AND THE U.S. MARITIME ADMINISTRATION (MARAD). THE VESSEL WAS DOCUMENTED UNDER THE DIRECTION OF TODD CROTEAU, HAER MARITIME PROGRAM CO-ORDINATOR AND ERHARD KOEHLER, MARAD SHIPS DISPOSAL CO-ORDINATOR. TEAM MEMBERS INCLUDED ARCHITECTS JOHNATHAN DOWSETT, ASHLEY T. WALKER, PHOTOGRAPHER DAVID HAAS AND HISTORIAN BRIAN CLAYTON.

HISTORIC AMERICAN ENGINEERING RECORD

USS *GAGE*
(APA-168)

HAER NO. VA-133

Rig/Type of Craft: VC2-S-AP5/Auxiliary

Trade: Attack Transport

Class: *Haskell*

Hull No.: APA-168

Principal Dimensions: Length (oa): 455'3"
Beam: 62'
Draft: 28'
Displacement: 12,450 (fl) tons

(The listed dimensions are "as built," but it should be noted that draft and displacement were subject to change over time)

Location: James River Reserve Fleet; Newport News vicinity; Newport News County, Virginia

Dates of Construction: 13 August 1944 – 14 October 1944

Designer: U.S. Maritime Commission

Builder: Oregon Shipbuilding Corporation; Portland, Oregon

Present Owner: U.S. Maritime Administration

Disposition: Inactive – National Defense Reserve Fleet

Significance: During the closing years of World War II, military planners requested that the Maritime Commission construct a new class of attack transports. Designers utilized the new *Victory* class and converted it into a troop transport for the U.S. Navy called the *Haskell* class, designated as VC2-S-AP5. The Maritime Commission constructed 117 attack transports during the war and

the *Gage* is the sole remaining ship afloat in its original configuration.

Author: Brian Clayton, fall 2007

Project Information: This project is part of the Historic American Engineering Record (HAER), a long-range program to document historically significant engineering and industrial works in the United States. The Heritage Documentation Programs of the National Park Service, U.S. Department of the Interior, administers the HAER program.

The project was prepared under the direction of Todd Croteau (HAER Maritime Program Coordinator). Jonathan Dowsett (HAER Intern Architect) generated vessel drawings. David Hass (HAER contract photographer) created large format photographs. A special thanks to Erhard Koehler (U.S. Maritime Administration) whose help and assistance greatly benefited our project.

Critical to the Allied success in World War II was the U.S. Maritime Commission. The Maritime Commission succeeded the U.S. Shipping Board in 1936, but followed the same directives. The Maritime Commission helped to develop and construct a variety of military and civilian ships for use during the war and the *Victory* class was one example. The *Victories* were primarily a point-to-point cargo ship, but their design was suitable for conversion to a troopship. Through input from the military, the Maritime Commission created the *Haskell* class by taking a standard *Victory* ship and reconfiguring the interior to accommodate troops. The Maritime Commission's design met the Marine Corps' requirements for amphibious operations in the Pacific during the closing years of World War II and it helped to facilitate the end of the Pacific war.¹

During the inter-war years, the U.S. Merchant Marine went through a series of fluctuations. After 1918, the majority of ships in the Merchant Marine were from the mobilization endeavor to support American troops in World War I, authorized by the United States Shipping Board. The Board approved the construction of 470 ships to support the war effort, but America's entry into the war was short lived. Between 1918 and 1922, the Board added an additional 1,300 ships to the Merchant Marine, which became the backbone of the fleet. In the mid-1920s, U.S. shipping companies were robust, but the U.S. stock market crash in 1929 was a major setback to the maritime industry. During the "Great Depression," many steamship companies suffered because they were unable to replace or update their aging ships – over ninety percent of the fleet was over twenty years old and had an average speed between 10-11 knots.²

In the mid-1930s, the government intervened with new legislation to aid the beleaguered maritime industry. President Franklin D. Roosevelt's "New Deal" economic policy eventually helped to revive the Merchant Marine when Congress passed the Merchant Marine Act of 1936. The act created the U.S. Maritime Commission, superseding the U.S. Shipping Board, and it infused new capital and ideas for rebuilding the fleet. By 1937, the Maritime Commission planned a long-range construction program to build 500 ships that were both contemporary and economical over a ten-year period. In 1939, the Maritime Commission determined that the production quota of fifty ships per year too low and doubled the original number to 1,000 ships or 100 ships per year.³

Also in 1939, the war in Europe began to trouble the United States and the Maritime Commission reacted accordingly. The success of the German U-boat campaign against English shipping alarmed the United States, whose steamship companies traded with England and France. The U.S. feared that Germany might

¹ Norman Friedman, *U.S. Amphibious Ships and Craft: An Illustrated Design History* (Annapolis: Naval Institute Press, 2002), pp. 188-189.

² Brian J. Cudahy, *Box Boats: How Container Ships Changed the World* (New York: Fordham University Press, 2006), pp. 2-3; L.A. Sawyer and W.H. Mitchell, *Victory Ships and Tankers: The History of the 'Victory' Type Cargo Ships and of the Tankers Built in the United States of America During World War II* (Cambridge, MD: Cornell Maritime Press, Inc., 1974), p. 15.

³ Cudahy, *Box Boats*, p. 3; Sawyer and Mitchell, *Victory Ships and Tankers*, p. 15.

target those ships and the Maritime Commission responded once more by raising their shipping quota in August 1940 to 200 ships per year.⁴

When the United States entered into World War II, the government setup an intensive shipbuilding program. On 3 January 1942, President Roosevelt declared that America would begin building a standard 11-knot ship in mass quantity, later called the “*Liberty*” ship, through an “Emergency Program” guided by the Maritime Commission. The *Liberties* were not aesthetic or fast, but were produced in great numbers to offset the German U-boat successes in the Atlantic campaign. By the end of war, the Maritime Commission produced over 2,700 *Liberty* ships, but a second-generation cargo ship supplanted *Liberty* ships.⁵

In 1943, the U.S. Maritime Commission proposed the construction of a new class of cargo vessels. American designers based their design on a British fast cargo ship, designed in 1942, which could operate outside of the convoy parameters. U.S. naval architects began drawing new plans for the cargo ship around a basic design; she was 445’ long, 63’ abeam, and had a draft of 28’. Planners instituted two key requirements for the new class: the deadweight had to equal a *Liberty* and it needed a minimum speed of 15 knots.⁶

During the design phase, the Maritime Commission made several changes in the new cargo ship. Architects from Bethlehem Steel developed the arrangement plans, while the Maritime Commission began work on the stability calculations and other considerations. Early on, the Maritime Commission realized that some shipyards designated to build the new ships could not fit a 63’ beam ship in their slipways. Architects then alter the ship’s design to accommodate a 62’ beam.⁷

The Maritime Commission approved the new drawings for the fast cargo ship in March 1943 and scheduled production to begin in April. The Maritime Commission designated the new ships as the *Victory* class and changed the prefix to VC2 in April 1944. In addition to speed, another consideration for building the *Victory* class was postwar disposal. American planners thought that the characteristics of the *Victory* class would appeal to ship owners and that the steamship companies would purchase the vessels at the conclusion of hostilities. The Maritime Commission planned a high production schedule for the *Victory* class to replace the *Liberty* class, but disagreements with the War Production Board stalled construction until the end of

⁴ Sawyer and Mitchell, *Victory Ships and Tankers*, p. 16.

⁵ Ibid.; Frederic C. Lane, *Ships for Victory: A History of Shipbuilding under the U.S. Maritime Commission in World War II* (Baltimore: John Hopkins Press, 1951), pp. 42-43.

⁶ Sawyer and Mitchell, *Victory Ships and Tankers*, p. 16; Lane, *Ships for Victory*, pp. 574-578.

⁷ Sawyer and Mitchell, *Victory Ships and Tankers*, p. 18; Lane, *Ships for Victory*, pp. 578-580.

1943. By the end of the war, U.S. shipyards had produced 414 Victory ships – 117 ships were converted attack transports (troopships).⁸

The Todd Shipyard Corporation headed the first five yards approved to construct “Emergency” ships at the beginning of World War II. Todd Shipbuilding was originally a major ship repair business with locations around the United States, but with an influx of orders, the Maritime Commission had to look for new builders. Henry J. Kaiser, part owner of Todd Shipbuilding in the Seattle-Tacoma Shipbuilding Corporation, was an important part of the expansion program during the war: Kaiser’s construction group⁹ helped build major “New Deal” projects: “Hoover, Bonneville, and Grand Coulee dams, and the Bay Bridge from San Francisco to Oakland.” Additionally, Kaiser’s construction base of men and equipment helped forge new shipbuilding companies around the United States.¹⁰

The Oregon Shipbuilding Company was the first business out of the original five emergency yards. Kaiser had investments within this company and his son, Edgar Kaiser, managed the yard. The Maritime Commission authorized the shipyard in February 1941 and began to construct the Oregon Shipbuilding Company in the northwestern suburb of Portland, Oregon along the Willamette River. On 19 May 1941, the shipyard laid the keel of the first ship, *Star of Oregon*. The original project called for eight ways to construct the ships and five outfitting docks to complete the vessels, but the Maritime Commission authorized the expansion of the yard to eleven ways and four outfitting docks to meet production quotas. The shipyard consolidated two outfitting docks into one to accommodate the longer *Victory* ships. The anticipated cost of the Oregon Shipbuilding facility in 1941 was \$7,196,000, but in actuality, the cost of the shipyard was estimated at \$25,171,000 in 1944. At the height of production, the shipyard employed 33,000 men and women.¹¹

During World War II, shipbuilders began using production line methods (prefabricated parts, assembly, construction of sections, and welding everything together), which significantly increased the quantity of ships. Additionally, the *Victories* also used a standardized design for all shipyards, but several different companies provided machinery. In March 1944, the Maritime Commission designated four shipyards to construct 117 VC2-S-AP5 *Victory* ships, and the Oregon Shipbuilding Company constructed 34 ships in that

⁸ Sawyer and Mitchell, *Victory Ships and Tankers*, pp. 18-20; Lane, *Ships for Victory*, pp. 586-607.

⁹ Besides Henry J. Kaiser, there were six other construction firms associated with Todd Shipbuilding: W.A. Bechtel Company; Bechtel-McCone-Parsons; General Construction Company; Morrison-Knudsen Company; MacDonald and Kahn, Incorporated; and Pacific Bridge Company.

¹⁰ Lane, *Ships for Victory*, pp. 53-54

¹¹ Lane, *Ships for Victory*, pp. 51, 54-55, 59, 472; “Oregon Shipbuilding Record Breakers,” <http://www.armed-guard.com/recbr1.html>, accessed 17 October 2007, pp. 4, 8, 11.

class. The shipyard completed the *Gage* and it was delivered to the U.S. Navy on 12 November 1944; the total production time took ninety days (sixty-two days on the way and twenty-nine days fitting out).¹²

Naval architects based the structure of the AP5 around a modified hull for berthing, cargo, and equipment for the assault troops. By the spring of 1944, American naval forces were preparing for the amphibious assaults in the Marianas and the timely production of troop transports would assist them with their invasion plans. Planners designed the ship to carry 1,596 troops (86 officers and 1,510 enlisted), 1,800 pounds of heavy vehicles and supplies, 25 assault boats, and 1 captain's gig. Architects specifically designated hold four as a cargo space (134,000 cu ft.) and dispersed the remaining troop cargo at the bottom of holds one and two. Gasoline tanks in the inner bottom carried 40,000 gallons of fuel for the landing craft and vehicles, while special davits and cranes assisted the ship's crew with the loading and unloading of their equipment. The ship's crew (28 officers, 23 CPOs, and 451 enlisted) was large enough to allow for a timely debarkation of troops upon arrival at the landing zone.¹³

Designers divided the ship into six areas to accommodate the ship's crew and the troops. The captain's quarters were beneath the bridge and berthing for the ship's officers were one deck below on the boat deck, complete with restrooms and showers. On the main deck, architects placed berthing for the troop officers, restrooms, shower facilities, the ship and troop officers' mess, a galley, doctors' offices, sick bay rooms, an operation room, and a radio room. The last berthing area for the ships' crew and troops comprised the second and platform deck – architects placed beds four high on both levels to maximize the space available. Other amenities for the enlisted were a mess hall, showers, and toilets. The main galley was amidships on the second deck, along with preparation rooms, reefers and food storage rooms on the third deck. The ship carried a distiller onboard and could generate up 40,000 gallons of water a day. Architects placed extensive ventilation ducts throughout the ship to temper the ship's crew and troops during the voyages in the sultry climate.¹⁴

Architects also refined the *Victory* class with two enhancements: higher speed and longer range. The *Gage* contained a Westinghouse cross-compound steam turbine with Westinghouse double-reduction gears. The engine rating was 8,500 horsepower that turned a 21'-7" propeller for a cruising speed of 15 knots and 17 knots at flank speed with a cruising range at 7,200 nautical miles. The Combustion Engineering boilers were oil fired and used forced draft water tubing with super heaters and economizers. The boilers working pressure was 465 pounds per square inch at 750°F. Engineers spaced the frames 36" apart to strengthen the hull and improve the ship's flexibility, which in turn reduced the stress fractures that affected the *Liberty* ships. The raking stem and cruiser stern promoted a more streamlined flow of water (better

¹² Lane, *Ships for Victory*, pp. 212-213; Sawyer and Mitchell, *Victory Ships and Tankers*, p. 32.

¹³ Daniel Marston, ed., *The Pacific War Companion: From Pearl Harbor to Hiroshima* (Oxford: Osprey Publishing, Ltd., 2005), pp. 166-169; Friedman, *U.S. Amphibious Ships and Craft: An Illustrated Design History*, pp. 168-169.

¹⁴ U.S. Maritime Administration, Plans and Files Section, "AP5 Troop Transport Design Breakdown Perspective," blueprint.

hydrodynamics). Auxiliary power came from three industrial diesel generators rated at 300 kilowatts apiece.¹⁵

During World War II, the Maritime Commission armed each ship with three types of guns (light, medium, and heavy) and positioned them around the ship to cover the four angles of attack. On the bow, architects placed a medium 40-millimeter Bofor quad mount and two more double-barrel mounts just aft on the port and starboard side atop the forecastle deck. On the boat deck were six light 20-millimeter Oerlikon anti-aircraft guns and four more above the bridge deck. One heavy 5"/38 dual-purpose gun (anti-aircraft and ship defense) was on the stern and two more double-barrel 40-millimeters overlooked the five-inch gun. Designers positioned the ammunition trucks under the bow and stern guns on the third deck and added elevators into the ship to transport the shells.¹⁶

The Maritime Commission delivered the *Gage* to the U.S. Navy on 4 November 1944 captained by Commander L.J. Alexanderson. She completed her shakedown cruise out of San Diego and departed for the South Pacific from San Francisco on 17 January 1945. She arrived off Guadalcanal 4 February 1945 with a complement of 298 marines and began training in amphibious warfare operations in the Solomon Islands for the next succession of battles. After staging in Ulithi for the assault on Okinawa, *Gage* departed and landed marine units from 3rd Battalion over the course of five days under the constant threat of Japanese kamikaze planes. After completing her assignment, she returned to San Francisco and arrived on 11 May 1945.¹⁷

Gage debarked from San Francisco in June 1945 and made several trips to the Philippine Islands transporting soldiers and equipment. Her first mission brought men from the Army Air Corps Casuals with their supplies to Manila on 12 June 1945. On 22 June 1945, *Gage* picked up marines in New Guinea and transported them Iloilo. After the troops debarked, *Gage* returned to San Francisco and while undergoing repairs at Todd's Dry Dock in Seattle the war ended.¹⁸

During postwar activities, *Gage* spent the next two years transporting troops between America and the Pacific before her decommissioning. On 21 August 1946, *Gage* departed Seattle with 1,724 Army personnel to replace soldiers on Saipan and two weeks later transported 1,500 marines to Japan. As part of "Magic-Carpet" (repatriating American servicemen), she returned 1,700 Army combat veterans to Portland, Oregon on 14 Dec. 1945. Two more "Magic-Carpet" trips transpired in January and April 1946 and she assisted navy personnel during the occupation of China and Japan. In her final mission, she

¹⁵ Sawyer and Mitchell, *Victory Ships and Tankers*, p. 38; Friedman, *U.S. Amphibious Ships and Craft*, pp. 168-169.

¹⁶ Sawyer and Mitchell, *Victory Ships and Tankers*, pp. 18, 37;

¹⁷ U.S. Navy, *Dictionary of American Naval Fighting Ships*, vol. III (Washington, DC: Naval Historical Center, 1991), p. 227.

¹⁸ *Ibid.*

repatriated Army veterans from the Marianas and Hawaii to Norfolk, via the Panama Canal and arrived on 29 July 1946. She remained in Norfolk Naval Shipyard until her decommissioning on 26 February and the U.S. Navy deactivated her on 1 October 1958, and she went into reserve status in the James River Reserve Fleet.¹⁹

Postwar assessment by the Marine Corps concluded that the *Haskell* class performed as expected, but there were deficiencies. The ship was large enough to carry an entire unit, but there was not enough room on board for the command staff when operations commenced. This led to a dilemma encountered during the war; the commanding officer lost command and control over the unit for a brief period before he disembarked the ship. The staff improvised by using small radios on the deck of the ship, but they disrupted the ship's communication system and it put the staff outside – vulnerable to the elements and the enemy. Final evaluation by the Marine Corp determined that the landing craft discharged in a protracted manner, ventilation was inadequate, and the ship did not distill enough water for the troops. Although these observations noted the problems experienced during World War II, the development and construction of new ships corrected those imperfections.²⁰

The *Gage* outlived her usefulness as a military vessel, but the *Haskell* class proved to be practical for many decades after World War II until the arrival of jet transports. In the mid-1960s, 55 percent of the attack transports in the fleet were from the *Haskell* class and 100 percent of the remaining ships were in the National Defense Reserve Fleet. As the military began to see the potential use of jet transports, it signaled the end of the troopship. In March 1973, Military Sealift Command formally struck the troopships *Barrett* and *Upshur* from its roster marking the end of an era as the United States strategically shifted its reliance on jet aircraft to deploy troops overseas.²¹

¹⁹ Ibid.

²⁰ Friedman, *U.S. Amphibious Ships and Craft*, pp. 192, 194.

²¹ Ibid., p. 190; Winn B. Frank, "Farewell to the Troopship," *Naval History* 11, no. 1 (1997): pp. 41-44.

Appendix A
Historic Photographs

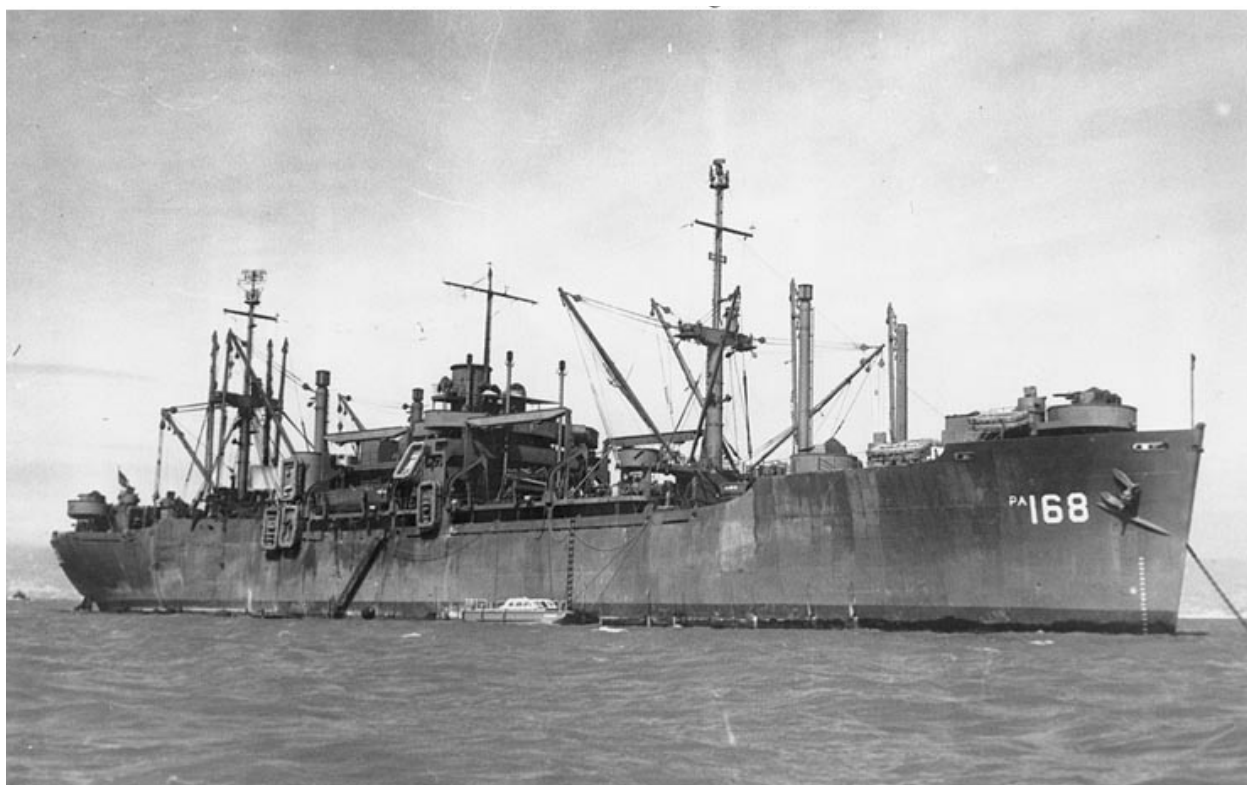

USS *Gage* moored, circa 1945
Naval Historical Center, NH83410



USS *Gage* in San Francisco Bay, circa 1945-1946

Naval Historical Center, NH98721

Select Bibliography

Books

- Cudahy, Brian J. *Box Boats: How Container Ships Changed the World*. New York: Fordham University Press, 2006.
- Friedman, Norman. *U.S. Amphibious Ships and Craft: An Illustrated Design History*. Annapolis: Naval Institute Press, 2002.
- Lane, Frederic C. *Ships for Victory: A History of Shipbuilding under the U.S. Maritime Commission in World War II*. Baltimore: John Hopkins Press, 1951.
- Marston, Daniel, ed. *The Pacific War Companion: From Pearl Harbor to Hiroshima*. Oxford: Osprey Publishing, Ltd., 2005.
- Sawyer, L.A. and W.H. Mitchell. *Victory Ships and Tankers: The History of the 'Victory' Type Cargo Ships and of the Tankers Built in the United States of America during World War II*. Cambridge: Cornell Maritime Press, Inc., 1974.
- U.S. Navy. *Dictionary of American Naval Fighting Ships*. Vol. III. Washington, DC: Naval Historical Center, 1968.

Article

- Frank, Winn B. "Farwell to the Troopship." *Naval History* 11, no. 1 (1997): pp. 41-45.

Internet Material

- "Oregon Shipbuilding Record Breakers." <http://www.armed-guard.com/recbr1.html>.

HISTORIC AMERICAN ENGINEERING RECORD

INDEX TO PHOTOGRAPHS

ATTACK TRANSPORT USS GAGE
(APA 168)
James River Reserve Fleet
Newport News vicinity
Virginia

HAER VA-133

Photos taken at James River Reserve Fleet.

INDEX TO BLACK AND WHITE PHOTOGRAPHS

David Haas, photographer, 2007

VA-133-1	Bow view.
VA-133-2	Stern view.
VA-133-3	General view of foredeck facing forward from midship. Hatch covers and king posts in foreground with gun mounts seen in background.
VA-133-4	View aft from fore deck. Cargo winches and gun mounts in foreground.
VA-133-5	Detail of starboard lifeboat davits.
VA-133-6	Rear deck view with hold cover facing aft.
VA-133-7	Detail of starboard fore deck gun turret mount looking starboard.
VA-133-8	First officer's cabin, port side, view to port.
VA-133-9	Officer's cabin, port side, view to port.
VA-133-10	Troop bunks, port side, view forward.
VA-133-11	Troop bunks, rear cargo hold, view to starboard.
VA-133-12	Rear troop berth ventilation unit, port side, view aft.

ATTACK TRANSPORT USS GAGE
HAER VA-133
INDEX TO PHOTOGRAPHS

- VA-133-13 Port side head, view forward.
VA-133-14 Starboard side mess area, view forward.
VA-133-15 Galley, view to starboard.
VA-133-16 Baking machinery, port side, view to port.

HISTORIC AMERICAN ENGINEERING RECORD
SEE INDEX TO PHOTOGRAPHS FOR CAPTION

HAER No. *VA-133-1*



HISTORIC AMERICAN ENGINEERING RECORD
SEE INDEX TO PHOTOGRAPHS FOR CAPTION

HAER No. *VA-133-2*



HISTORIC AMERICAN ENGINEERING RECORD
SEE INDEX TO PHOTOGRAPHS FOR CAPTION

HAER No. VA-133-3



HISTORIC AMERICAN ENGINEERING RECORD
SEE INDEX TO PHOTOGRAPHS FOR CAPTION

HAER No. VA-133-4

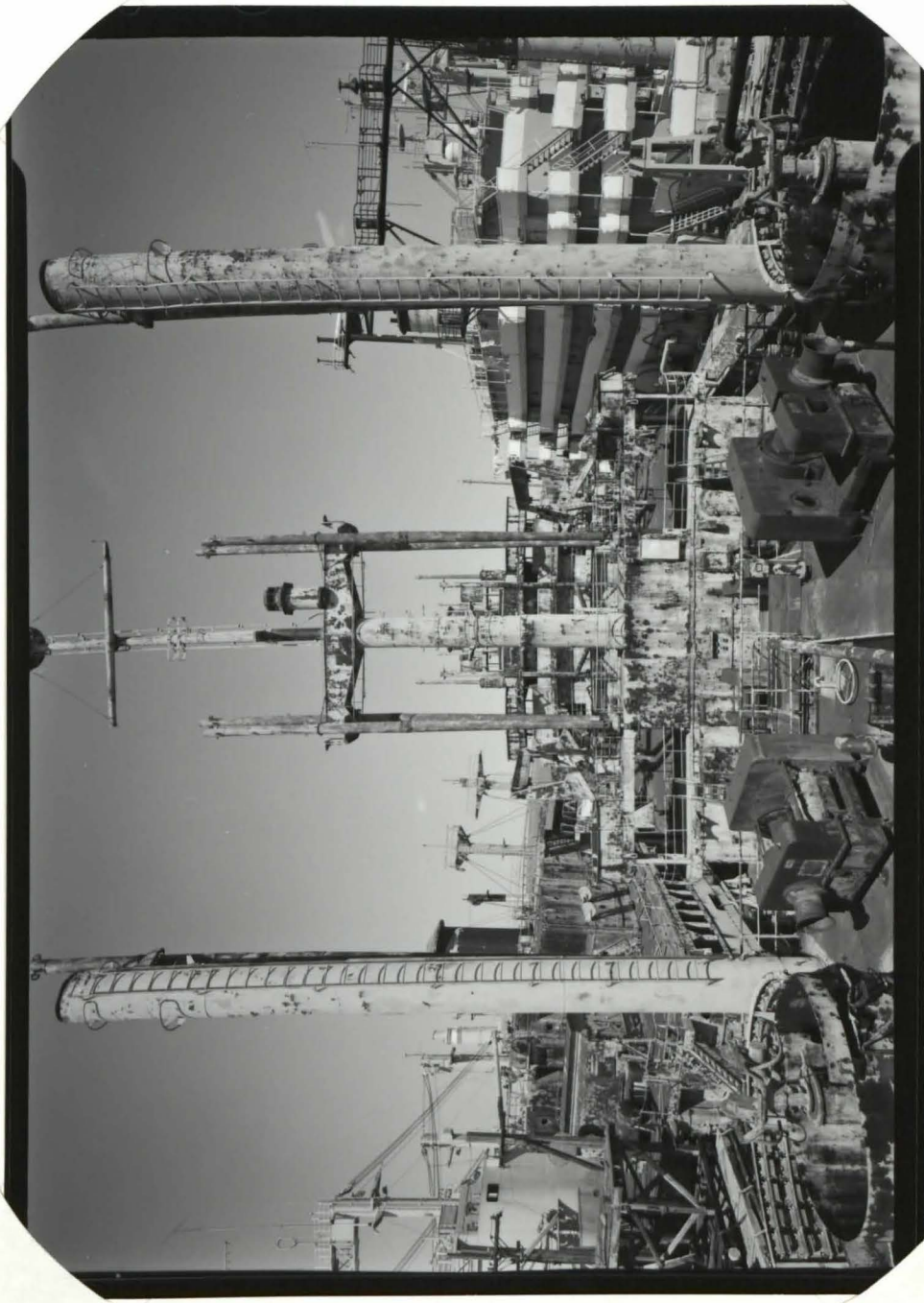

HISTORIC AMERICAN ENGINEERING RECORD
SEE INDEX TO PHOTOGRAPHS FOR CAPTION

HAER No. VA-133-5



HISTORIC AMERICAN ENGINEERING RECORD
SEE INDEX TO PHOTOGRAPHS FOR CAPTION

HAER No. VA-133-6



HISTORIC AMERICAN ENGINEERING RECORD
SEE INDEX TO PHOTOGRAPHS FOR CAPTION

HAER No. VA-133-7

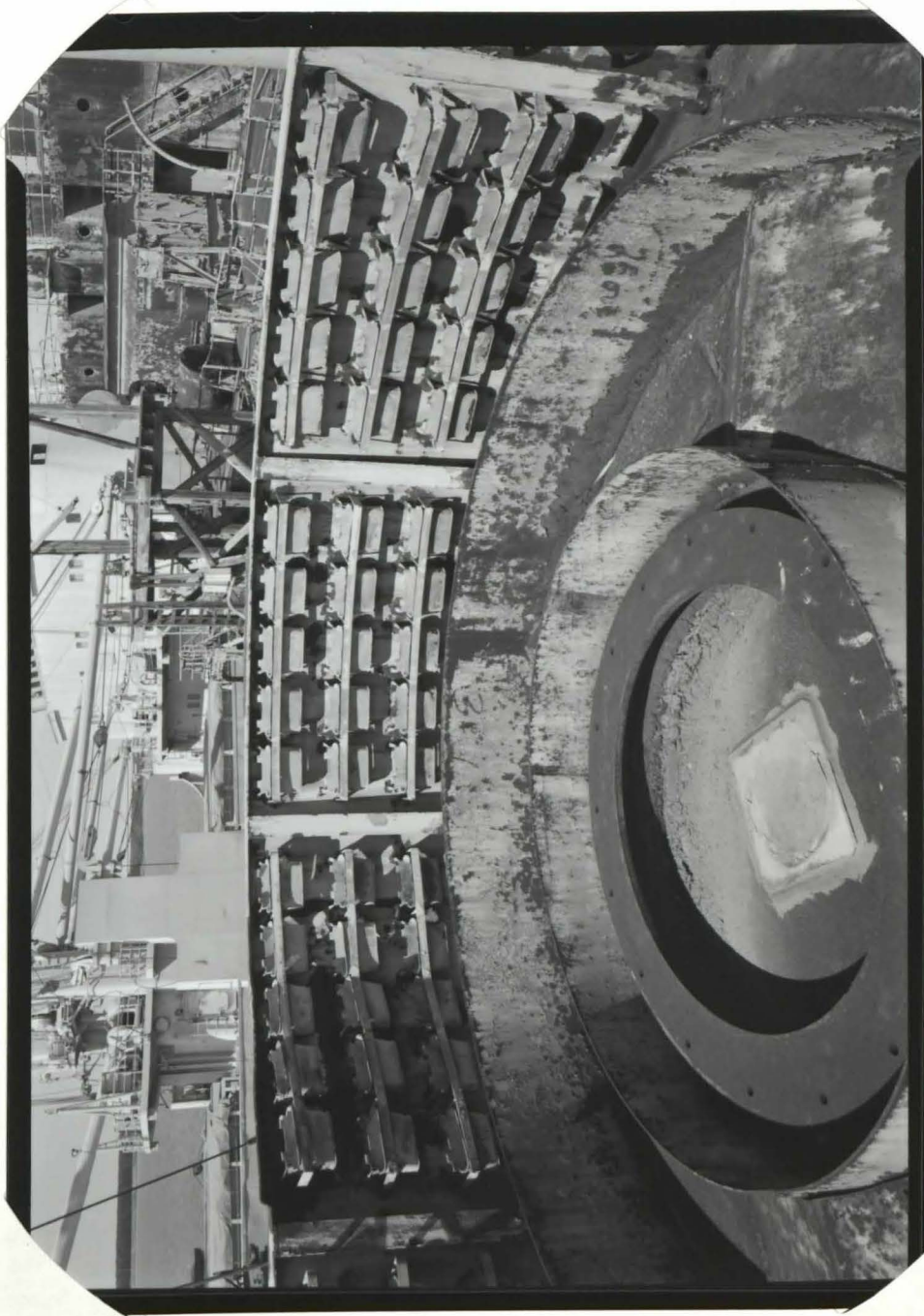

HISTORIC AMERICAN ENGINEERING RECORD
SEE INDEX TO PHOTOGRAPHS FOR CAPTION

HAER No. VA-133-8

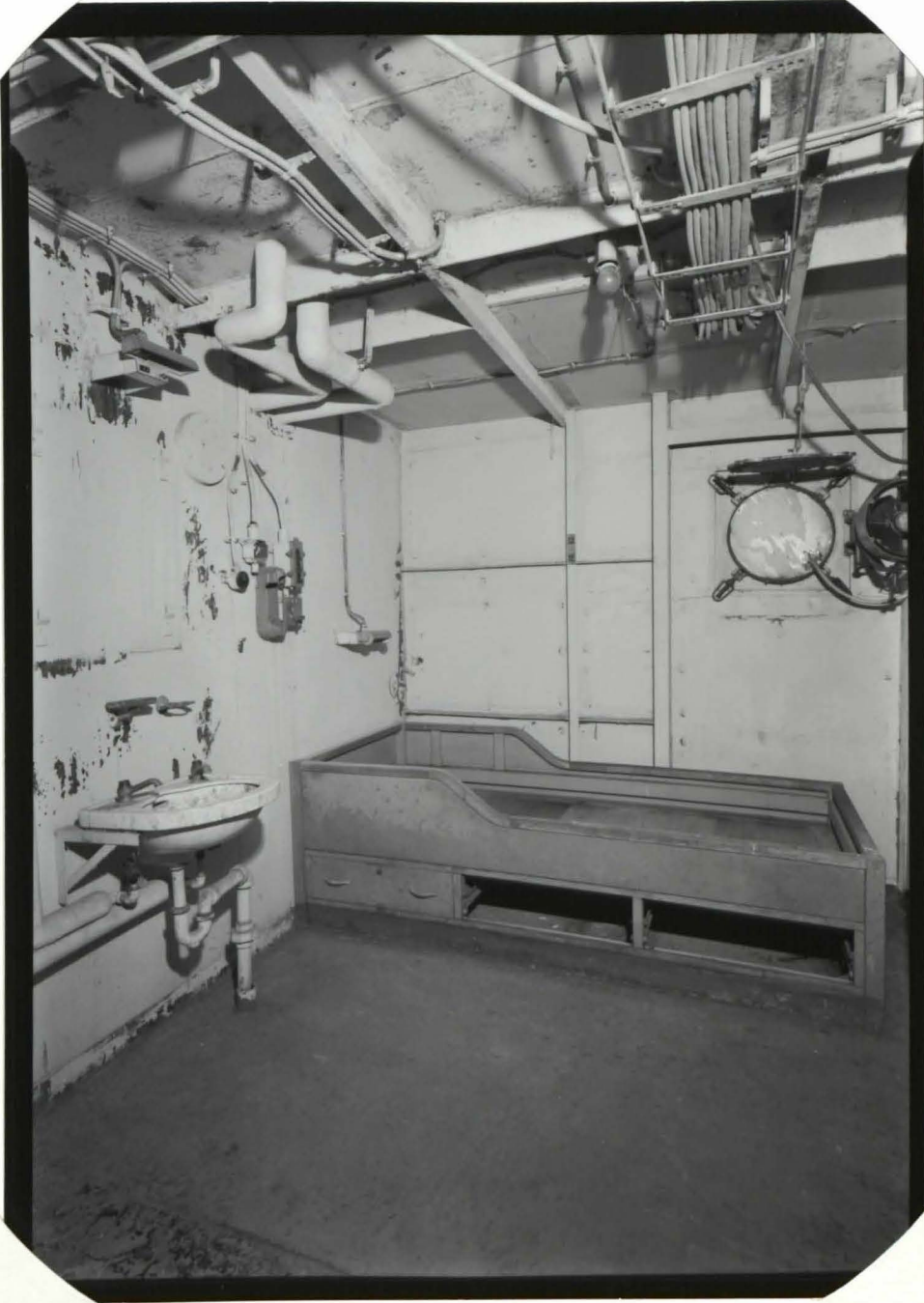

HISTORIC AMERICAN ENGINEERING RECORD
SEE INDEX TO PHOTOGRAPHS FOR CAPTION

HAER No. VA-133-9



HISTORIC AMERICAN ENGINEERING RECORD
SEE INDEX TO PHOTOGRAPHS FOR CAPTION

HAER No. *VA-133-10*

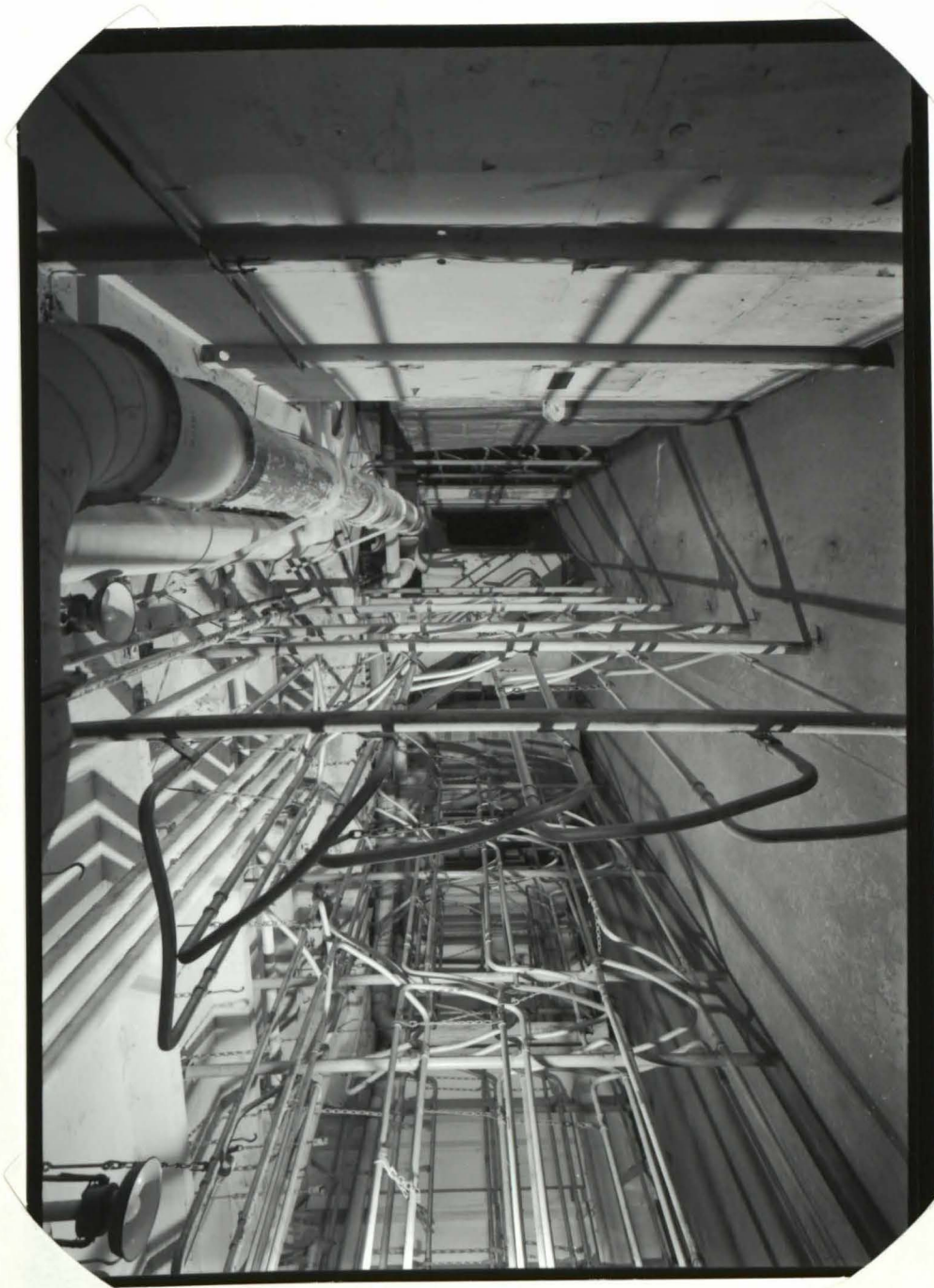

HISTORIC AMERICAN ENGINEERING RECORD
SEE INDEX TO PHOTOGRAPHS FOR CAPTION

HAER No. VA-133-11



HISTORIC AMERICAN ENGINEERING RECORD
SEE INDEX TO PHOTOGRAPHS FOR CAPTION

HAER No. VA-133-12



HISTORIC AMERICAN ENGINEERING RECORD
SEE INDEX TO PHOTOGRAPHS FOR CAPTION

HAER No. VA-133-13



HISTORIC AMERICAN ENGINEERING RECORD
SEE INDEX TO PHOTOGRAPHS FOR CAPTION

HAER No. VA-133-14

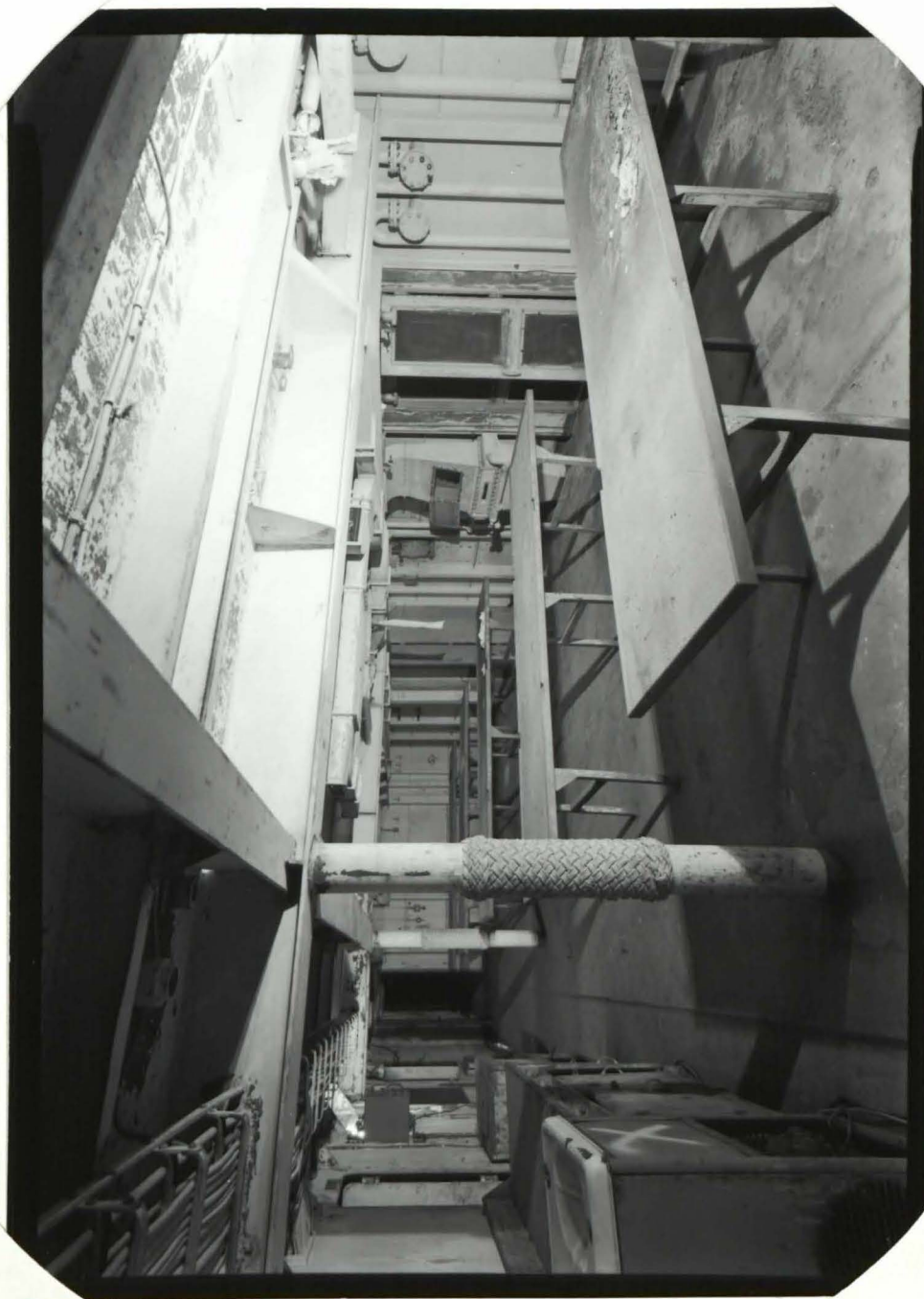

HISTORIC AMERICAN ENGINEERING RECORD
SEE INDEX TO PHOTOGRAPHS FOR CAPTION

HAER No. VA-133-15



HAER No. VA-133-16

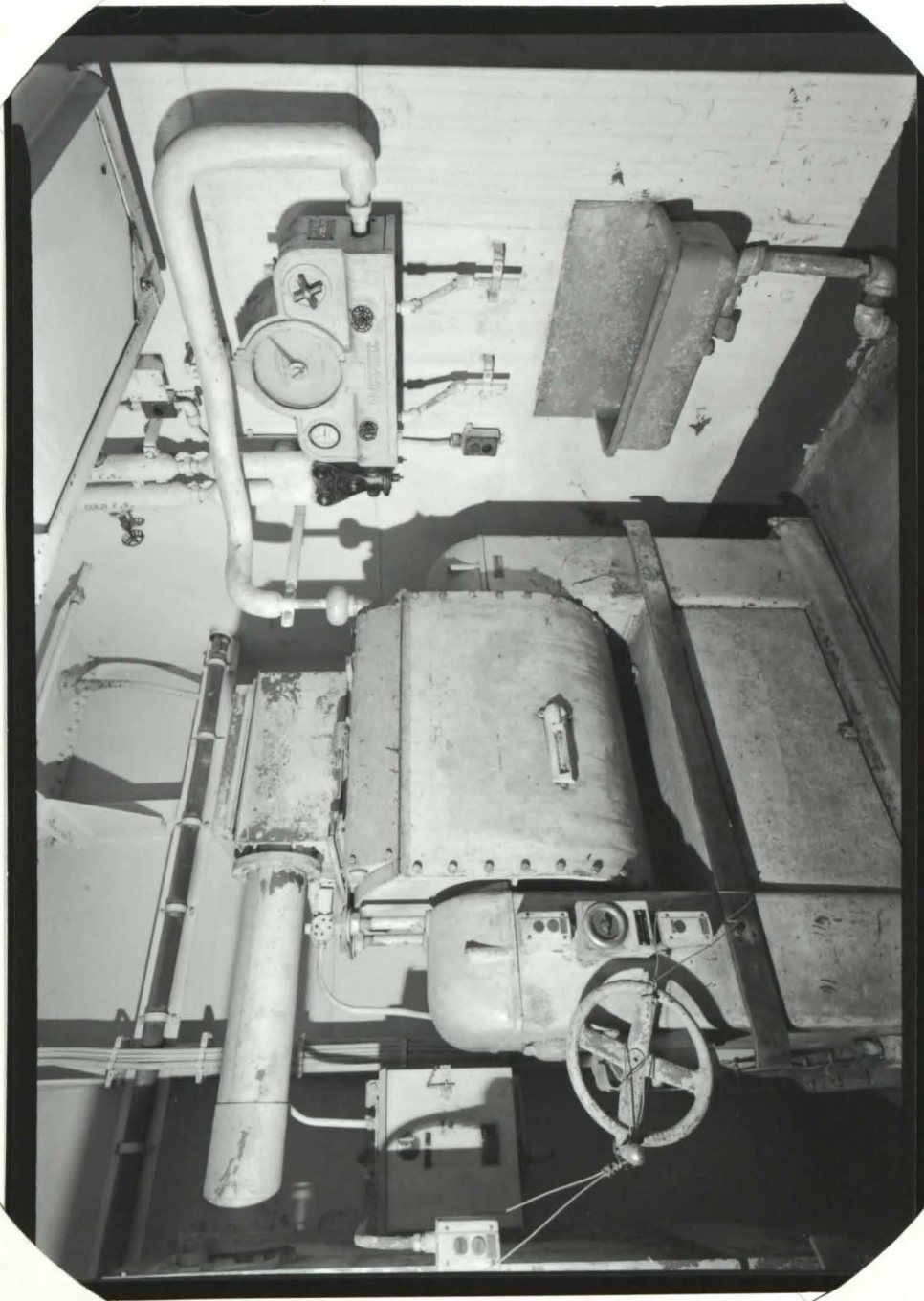

USS Gage

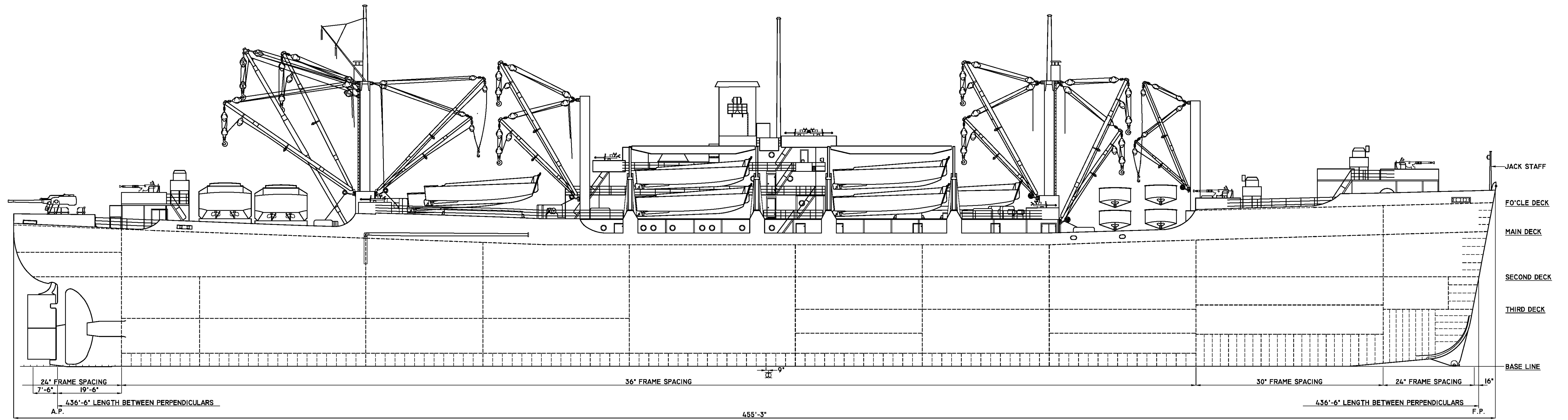

OUTBOARD PROFILE

NOTE: DRAWINGS TRACED FROM SCANS OF ORIGINAL DESIGN DRAWINGS (M.C PLAN No. VC2-AP5-S9-0-8)

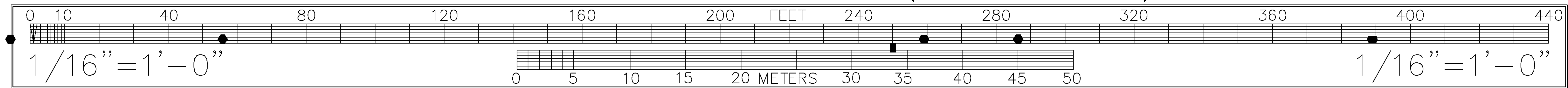

USS Gage

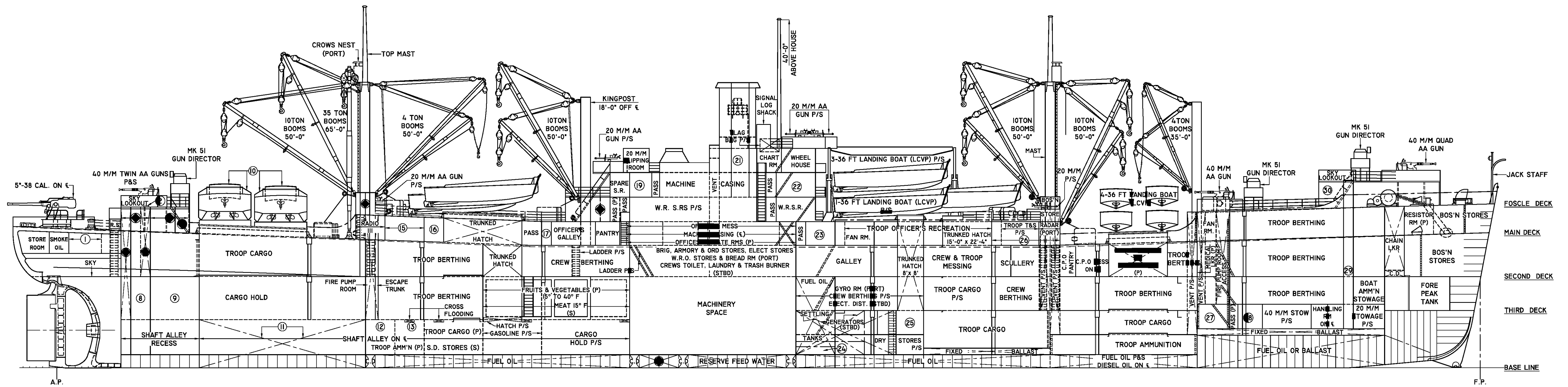

INBOARD PROFILE

NOTE: DRAWINGS TRACED FROM SCANS OF ORIGINAL DESIGN DRAWINGS (M.C PLAN No. VC2-AP5-S9-0-8)

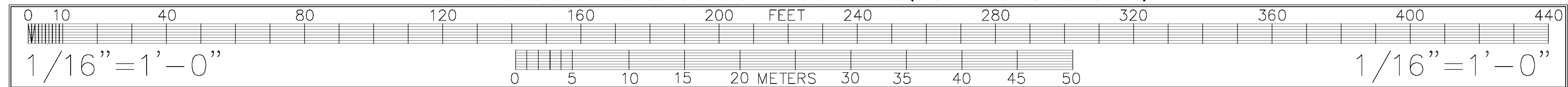

SCHEDULE OF ROOMS & FEATURES OF VESSEL

NO.	NAME/ TITLE	NO.	NAME/ TITLE	NO.	NAME/ TITLE	NO.	NAME/ TITLE	NO.	NAME/ TITLE
1	CAPSTAN MACHINE (P) EMERGENCY GEN. ROOM (S)	7	AMMUNITION ROOM ESCAPE TRUNK (P)	13	PAINT LUB. OIL AND INFLAMMABLE LIQUID (P)	19	LINEN LOCKER (P) OFFICERS T&S (S)	25	DRY STORES (S) S.D. STORES (P)
2	PASSING SCUTTLE	8	HANDLING ROOM AND 5"-38 PROJ. STOW	14	RADAR (P) BATTERY ROOM	20	DIESEL OIL P/S SUMP ON CENTER LINE	26	TROOP OFFICER'S ON CENTER LINE
3	RADAR (P) 40 M/M R.S. (S)	9	5"-38 POWDER (P) 40 M/M AMMUNITION (S)	15	ISOLATION WARD (P) INSANE WARD (S)	21	EMER. S.R. & DECK T&S (P) RADAR INDICATOR ROOM (S)	27	CLOTHING STORES (P) DIESEL FIRE PUMP ROOM (S)
4	BOAT ENGINE REPAIR AND CARPENTER SHOP	10	1-36 FT LANDING BOAT (LCVP) NESTED IN EACH 50 FT TANK LIGHTER (LCMS)	16	DISPENSARY	22	UNIT COMM'DRS S.R. (P) CAPTAIN CABIN C.L. CAPTAIN'S S.R. (S)	28	CLOTHING (P) S.D. STORES (S)
5	AFTER REPAIR PARTY LOCKER	11	FRESH WATER P/S AND UNDER SHAFT ALLEY	17	MEDICAL SUPPLY LOCKER	23	TRANS. & Q.M. OFF (P) SHIP'S OFFICE TR. MESSAGE CENTER	29	AMMUNITION HOIST (S) ACCESS TRUNK (P)
6	AMMUNITION TRUNK (P) SHAFT ALLEY ESCAPE (S)	12	DIESEL FIRE PUMP ROOM (P)	18	BATTERY ROOM (P) OFFICERS SHOW (STBD)	24	COFERDAM UNDER DISTILLED WATER (S)	30	40 M/M R.S. (P) RADAR (S)

USS Gage

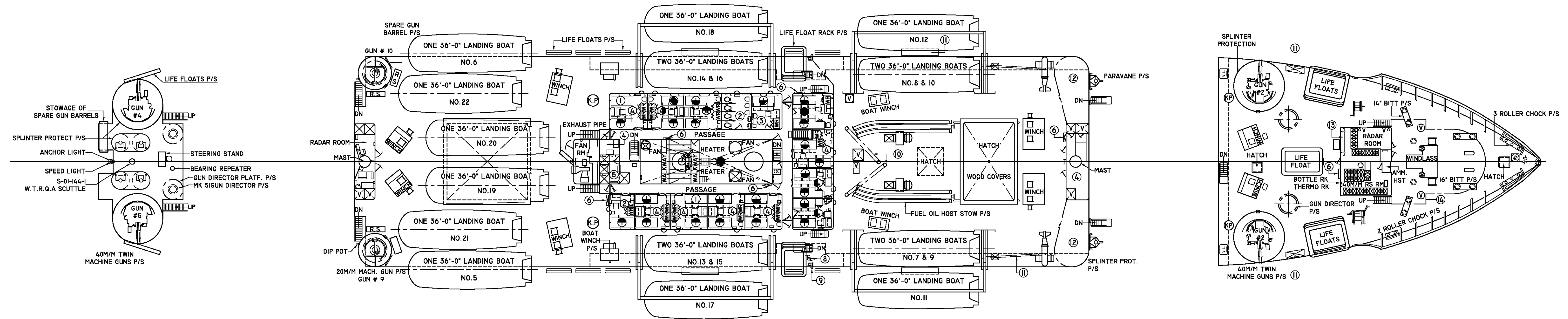

MACHINE GUN PLATFORM

BOAT DECK

FORECASTLE

NOTE: DRAWINGS TRACED FROM SCANS OF ORIGINAL DESIGN DRAWINGS (DWG. NUMBER: APA117-S0103-50933)

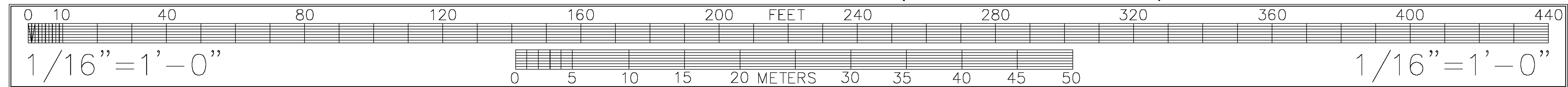

SCHEDULE OF ROOMS & FEATURES OF VESSEL

NO.	NAME/ TITLE	NO.	NAME/ TITLE	NO.	NAME/ TITLE	NO.	NAME/ TITLE	NO.	NAME/ TITLE
1	OFFICER'S BERTHING	4	LIFEBOAT CONTROL ROOM	7	MACHINE CASING B-1	10	GALLEY RANGE EXHAUST PIPE	13	SPARE 40M/M GUN BAR
2	OFFICER'S TOILET	5	OFFICER'S SHOWERS	8	SOUNDING MACHINE	11	DEBARKATION LADDER P/S (STOWED)	14	GUN PLATFORM OVER
3	TROOP COMMODORES	6	FIRE STATIONS	9	SOUNDING BOOM P/S (STOWED)	12	20M/M MACHINE GUN P/S OVER		

USS GAGE (APA-168)
JAMES RIVER RESERVE FLEET
NEWPORT NEWS COUNTY

NEWPORT NEWS VICINITY

HAER MARITIME RECORDING PROJECT
NATIONAL PARK SERVICE
UNITED STATES DEPARTMENT OF THE INTERIOR

HISTORIC AMERICAN ENGINEERING RECORD
INDEX NUMBER
VA-133

SHEET 4 OF 11

SCANNED FROM HISTORIC DRAWINGS AND REFORMATTED BY: ASHLEY T. WALKER, 2009

REPRODUCED PLEASE CREDIT THE HISTORIC AMERICAN ENGINEERING RECORD, NATIONAL PARK SERVICE, NAME OF DELIVERATOR, DATE OF DRAWING

USS Gage

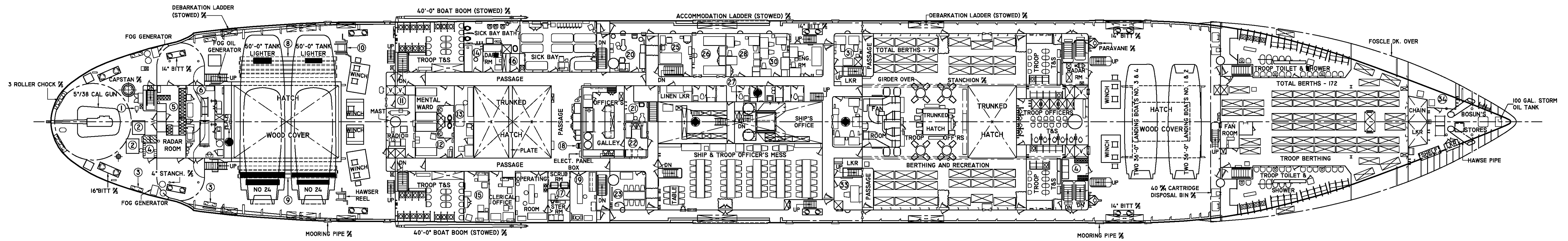

MAIN DECK

NOTE: DRAWINGS TRACED FROM SCANS OF ORIGINAL DESIGN DRAWINGS (DWG. NUMBER: AP117-S0103-50933)

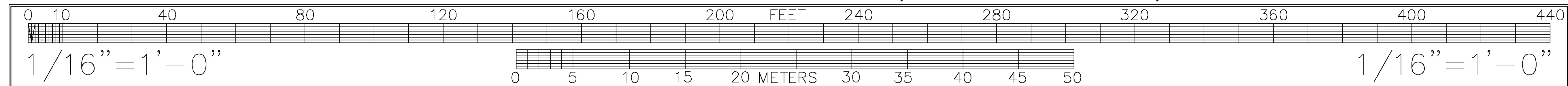

SCHEDULE OF ROOMS & FEATURES OF VESSEL

NO.	NAME/ TITLE	NO.	NAME/ TITLE	NO.	NAME/ TITLE	NO.	NAME/ TITLE	NO.	NAME/ TITLE	NO.	NAME/ TITLE
1	CAPSTAN MASTER CONTROL SWITCH	7	STREAM ANCHOR (STOWED)	13	DISPENSARY	19	SURGICAL DRESSING ROOM	25	SENIOR TROOP OFFICER'S	31	TRANSPORT QUARTER MAST'S OFFICE
2	5"/38 CALIBER PROJECTILE BOX	8	5 LENGTHS FUEL OIL HOSE STOW	14	BACTERIA LABORATORY	20	DENTAL OFFICE	26	4 TROOP OFFICERS	32	SHIP'S OFFICE
3	2 ROLLER CHOCK P/S	9	3 LENGTHS FUEL OIL HOSE STOW	15	DOCTOR'S OFFICE	21	PROPHYLACTIC ROOM	27	4 TROOP OFFICERS TOILET	33	TROOP MESSAGE CENTER
4	REPAIR PARTY LOCKER	10	STREAMLINE REEL	16	DIET KITCHEN	22	OFFICER'S PANTRY	28	PAY AND SUPPLY OFFICE	34	RESISTOR ROOM
5	40MM READY SERVICE ROOM	11	FIRE PUMP ROOM ESCAPE TRUNK	17	STERILIZER EQUIPMENT ROOM	23	TROOP CONFERENCE ROOM	29	4 TROOP OFFICERS SHOWERS		
6	BOAT ENGINE REP. AND CARPENTER SHOP	12	ISOLATION WARD	18	MKS FOR LITTER STOWAGE	24	MACHINERY CASING	30	1ST LIEUTENANT & GUNNERY OFFICERS OFFICE		

USS GAGE (APA-168)
JAMES RIVER RESERVE FLEET
NEWPORT NEWS COUNTY
NEWPORT NEWS VICINITY

SCANNED FROM HISTORIC DRAWINGS AND REFORMATTED BY: ASHLEY T. WALKER, 2009
NAVER MARITIME RECORDING PROJECT
NATIONAL PARK SERVICE
UNITED STATES DEPARTMENT OF THE INTERIOR

HISTORIC AMERICAN ENGINEERING RECORD
INDEX NUMBER
VA-133
SHEET
5 OF 11
VIRGINIA

REPRODUCED PLEASE CREDIT THE HISTORIC AMERICAN ENGINEERING RECORD, NATIONAL PARK SERVICE, NAME OF DELINEATOR, DATE OF DRAWING

USS Gage

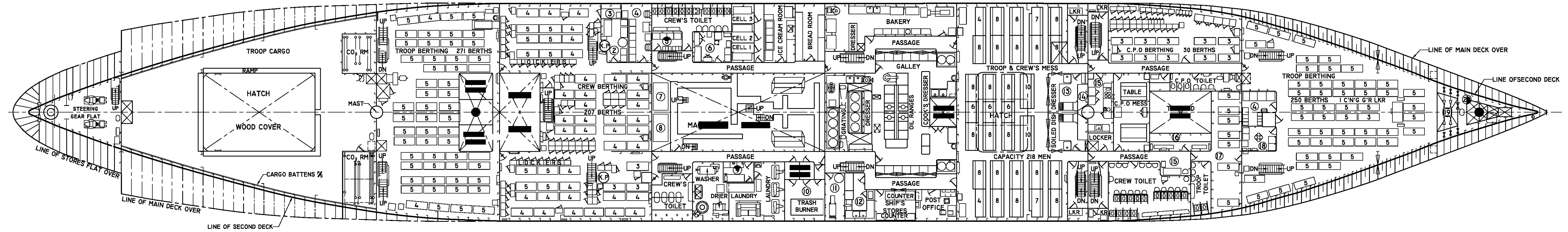

SECOND DECK

NOTE: DRAWINGS TRACED FROM SCANS OF ORIGINAL DESIGN DRAWINGS (DWG. NUMBER: APA117-S0103-509031)

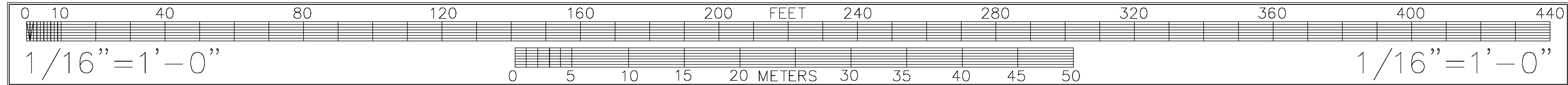

SCHEDULE OF ROOMS & FEATURES OF VESSEL

NO.	NAME/ TITLE	NO.	NAME/ TITLE	NO.	NAME/ TITLE	NO.	NAME/ TITLE	NO.	NAME/ TITLE	NO.	NAME/ TITLE
1	HATCH WOOD COVER	5	PROVISION ISSUE ROOM	9	ISSUE AND RECEIVING ROOM	13	SCULLERY	17	TROOP BERTHING	21	STEEL GRATING
2	ELECTRICAL STORAGE	6	ARMORY AND ORDINANCE	10	TRASH BURNER ROOM	14	CLEAN DISH DRESSER	18	REPAIR PARTY LOCKER		
3	LAUNDRY	7	L.O. SETTLING TANK	11	GARBAGE GRINDER ROOM	15	C.P.O PANTRY	19	CHAIN LOCKER SUMP TANK UNDER		
4	MEDICAL STORES	8	L.O. STORAGE TANK	12	BUTCHER ROOM	16	CREW SHOWER AND DECONTAMINATION SPACE	20	BOSUN'S STORES		

USS GAGE (APA-168)
JAMES RIVER RESERVE FLEET
NEWPORT NEWS COUNTY

SCANNED FROM HISTORIC DRAWINGS AND REFORMATTED BY: ASHLEY T. WALKER, 2009

HAER MARITIME RECORDING PROJECT
NATIONAL PARK SERVICE
UNITED STATES DEPARTMENT OF THE INTERIOR

SHEET 6 OF 11
HISTORIC AMERICAN ENGINEERING RECORD
INDEX NUMBER VA-133

VIRGINIA

NEWPORT NEWS VICINITY

IF REPRODUCED, PLEASE CREDIT THE HISTORIC AMERICAN ENGINEERING RECORD, NATIONAL PARK SERVICE, NAME OF DELINEATOR, DATE OF DRAWING

USS Gage

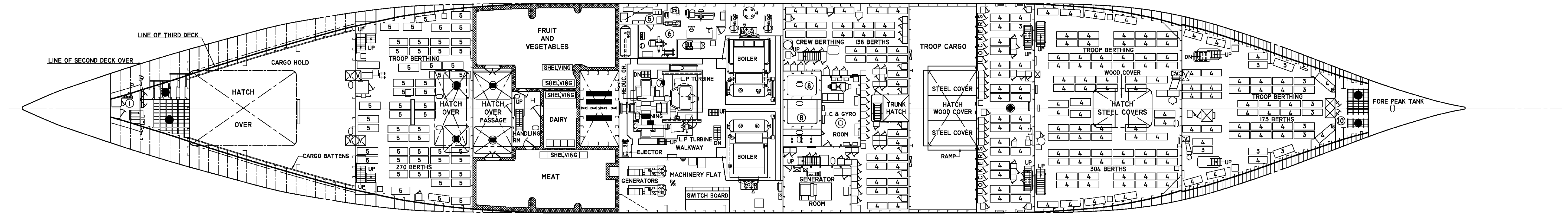

THIRD DECK

NOTE: DRAWINGS TRACED FROM SCANS OF ORIGINAL DESIGN DRAWINGS (DWG. NUMBER: APA117-S0103-509031)

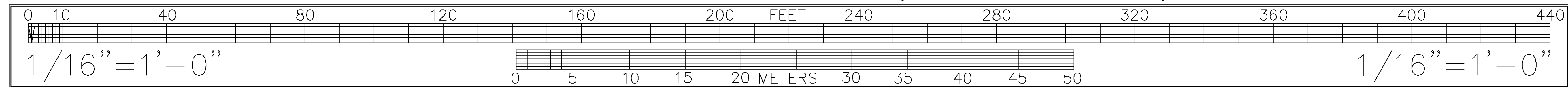

SCHEDULE OF ROOMS & FEATURES OF VESSEL

NO.	NAME/ TITLE	NO.	NAME/ TITLE	NO.	NAME/ TITLE	NO.	NAME/ TITLE
1	5"/38 C&I P&M ROOM	4	HATCH STEEL COVER	7	MACHINERY CASING	10	BOAT AMMUNITION MAGAZINE
2	3"/38 P. STOWAGE	5	ENGINEER'S STORES	8	F.O. SETTLING TANK	11	30 CALIBER AMMUNITION
3	40 MM AMMUNITION STOWAGE	6	ENGINEER'S WORKSHOP	9	CREW BERTHING 102 BERTHS		

USS Gage

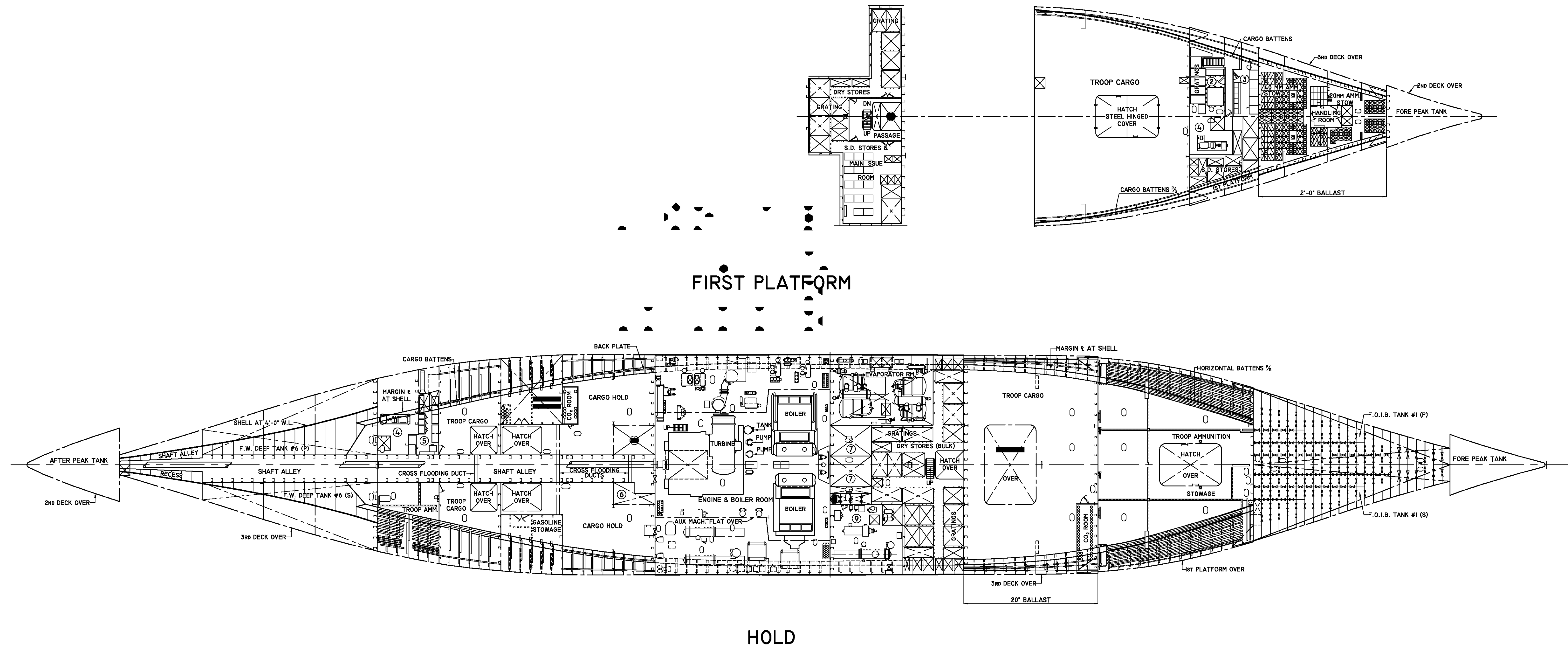

NOTE: DRAWINGS TRACED FROM SCANS OF ORIGINAL DESIGN DRAWINGS (DWG. NUMBER: APA117-S0103-509034)

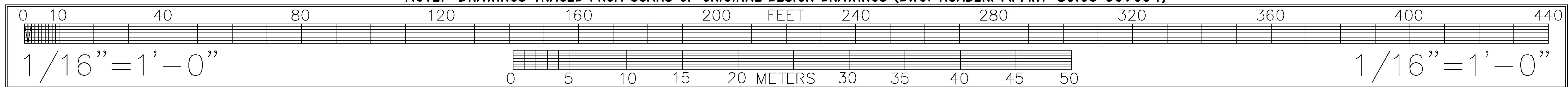

SCHEDULE OF ROOMS & FEATURES OF VESSEL

NO.	NAME/ TITLE	NO.	NAME/ TITLE	NO.	NAME/ TITLE	NO.	NAME/ TITLE	NO.	NAME/ TITLE
1	HATCH WOOD COVER HATCH STEEL HINGED COVER	3	CLOTHING AND Q.S.K. ISSUE ROOM	5	PAINT AND INFLAMMABLE LIQUID AND LUBRICATE OIL STOWAGE	7	F.O. SETTLING TANK	9	GENERATOR ROOM
2	CLOTHING STORES ROOM	4	DIESEL FIRE PUMP ROOM	6	COFFERDAM UNDER THIRD DECK	8	DISTILLED WATER TANK		

USS GAGE (APA-168)
 JAMES RIVER RESERVE FLEET
 NEWPORT NEWS COUNTY

NEWPORT NEWS VICINITY

SCANNED FROM HISTORIC DRAWINGS AND REFORMATTED BY: ASHLEY T. WALKER, 2009
 NAVER MARITIME
 RECORDING PROJECT
 NATIONAL PARK SERVICE
 UNITED STATES DEPARTMENT OF THE INTERIOR

HISTORIC AMERICAN
 ENGINEERING RECORD
 SHEET 8 OF 11
 VIRGINIA VA-133

REPRODUCED, PLEASE CREDIT THE HISTORIC AMERICAN ENGINEERING RECORD, NATIONAL PARK SERVICE, NAME OF DRAFTER, DATE OF DRAWING

USS Gage

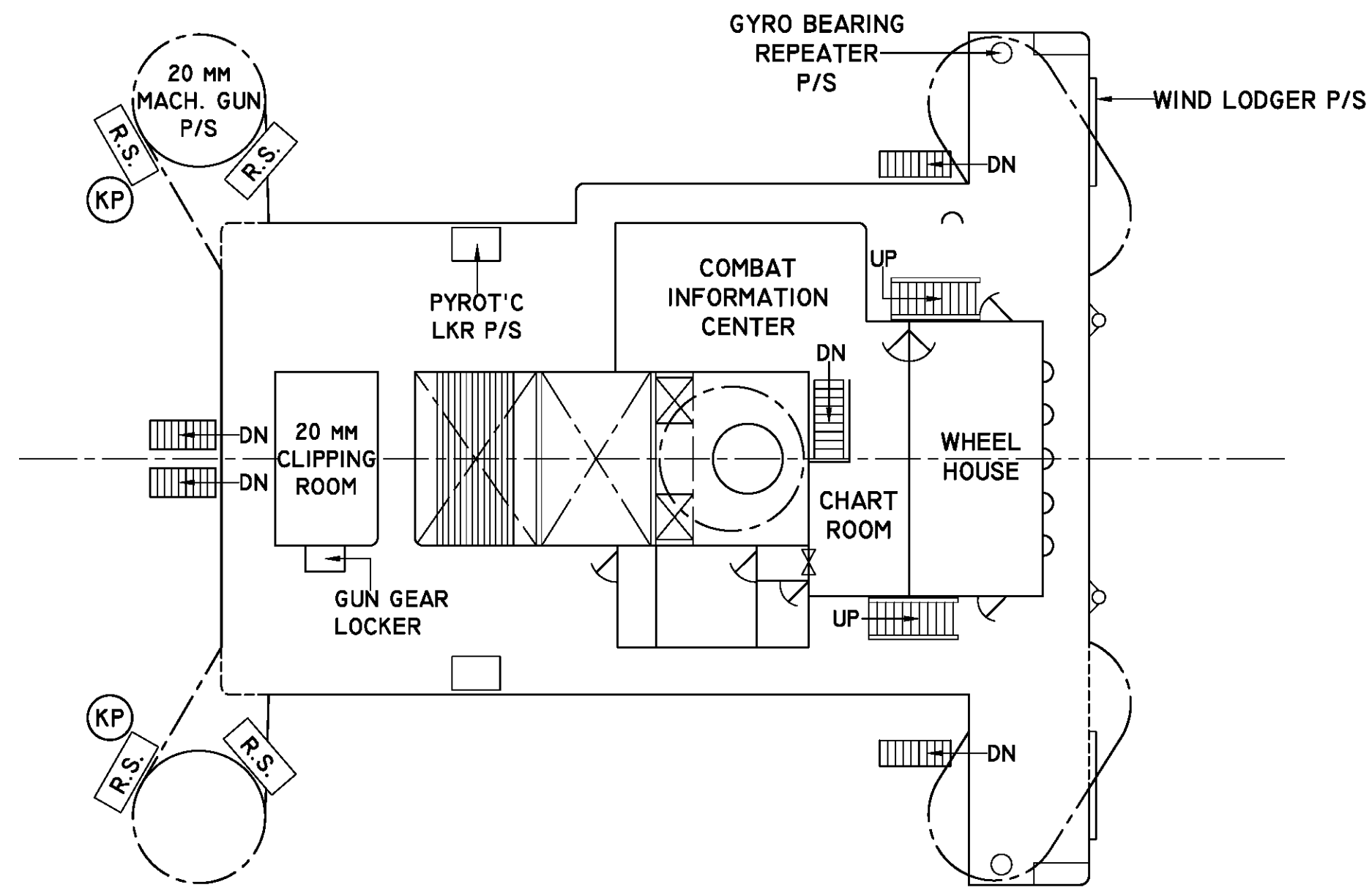

BRIDGE DECK

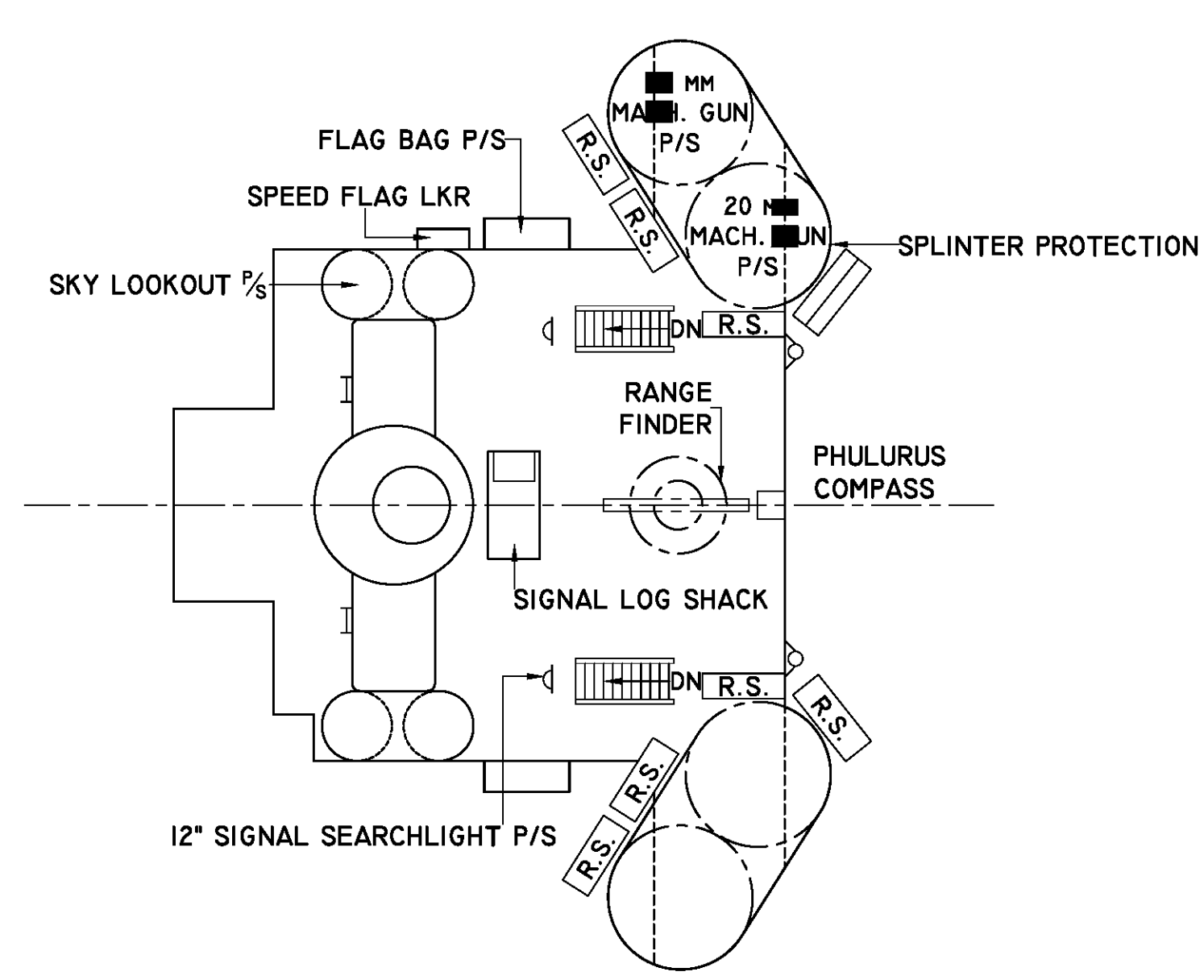

TOP OF HOUSE

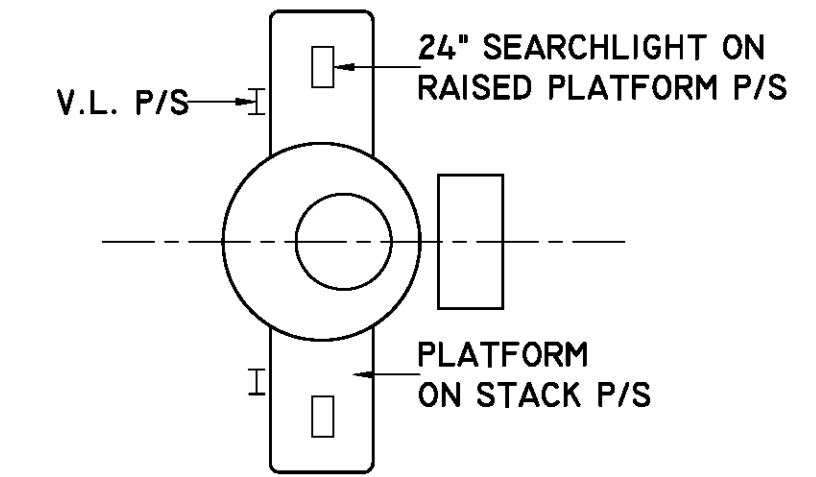

PLATFORM ON STACK

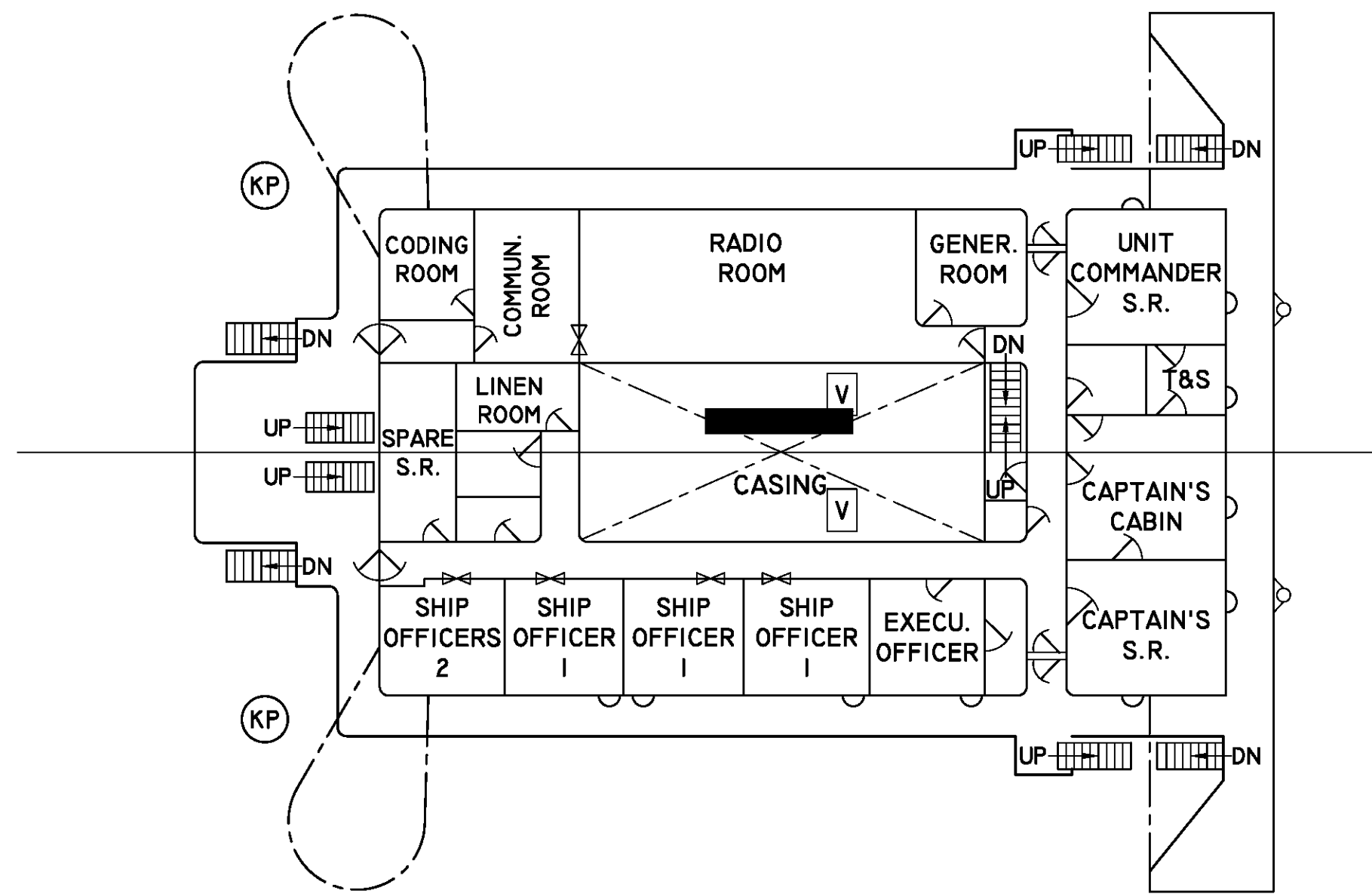

CABIN DECK

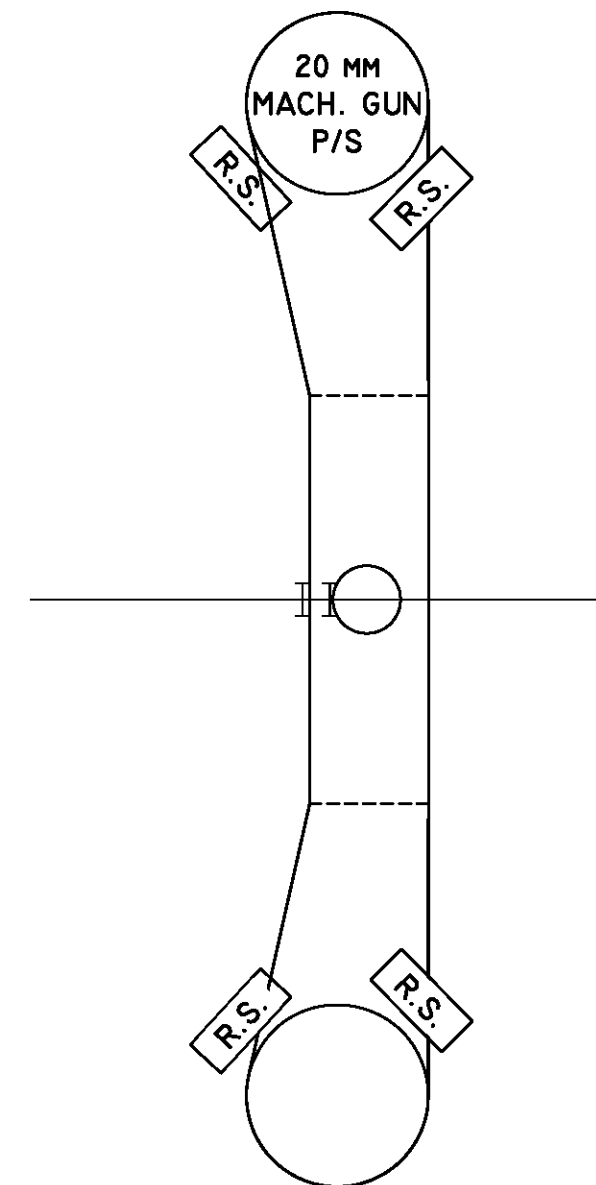

GUN PLATFORM

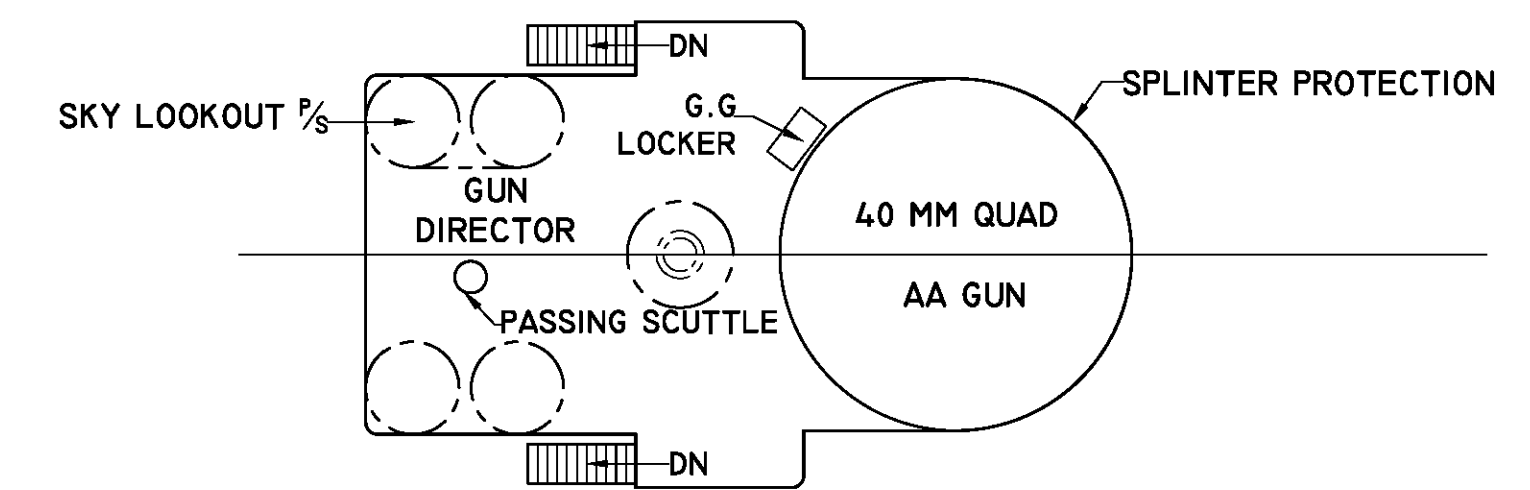

FORWARD GUN PLATFORM

NOTE: DRAWINGS TRACED FROM SCANS OF ORIGINAL DESIGN DRAWINGS (U.S.M.C PLAN No. MCV-AP5-S9-0-7A)

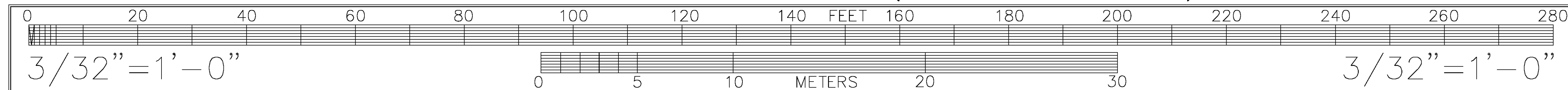

USS Gage

SCHEDULE OF FEATURES OF VESSEL			
NO.	NAME/ TITLE	NO.	NAME/ TITLE
1	9'-6" DECK LEVEL P/S	5	1" STRAIGHT CAMBER IN 3'-7" P/S
2	DECK CAMBER STRAIGHT LINE 6" AT 9'-6" OFF \bar{C} P/S	6	OIL SKIN LOCKER M.J. DOOR 24"x72" WITH 3" SILL
3	M.J. DOOR 26" WIDE 1/2" MINIMUM SILL	7	COMBAT INFORMATION CENTER
4	6'-6" DECK LEVEL P/S		

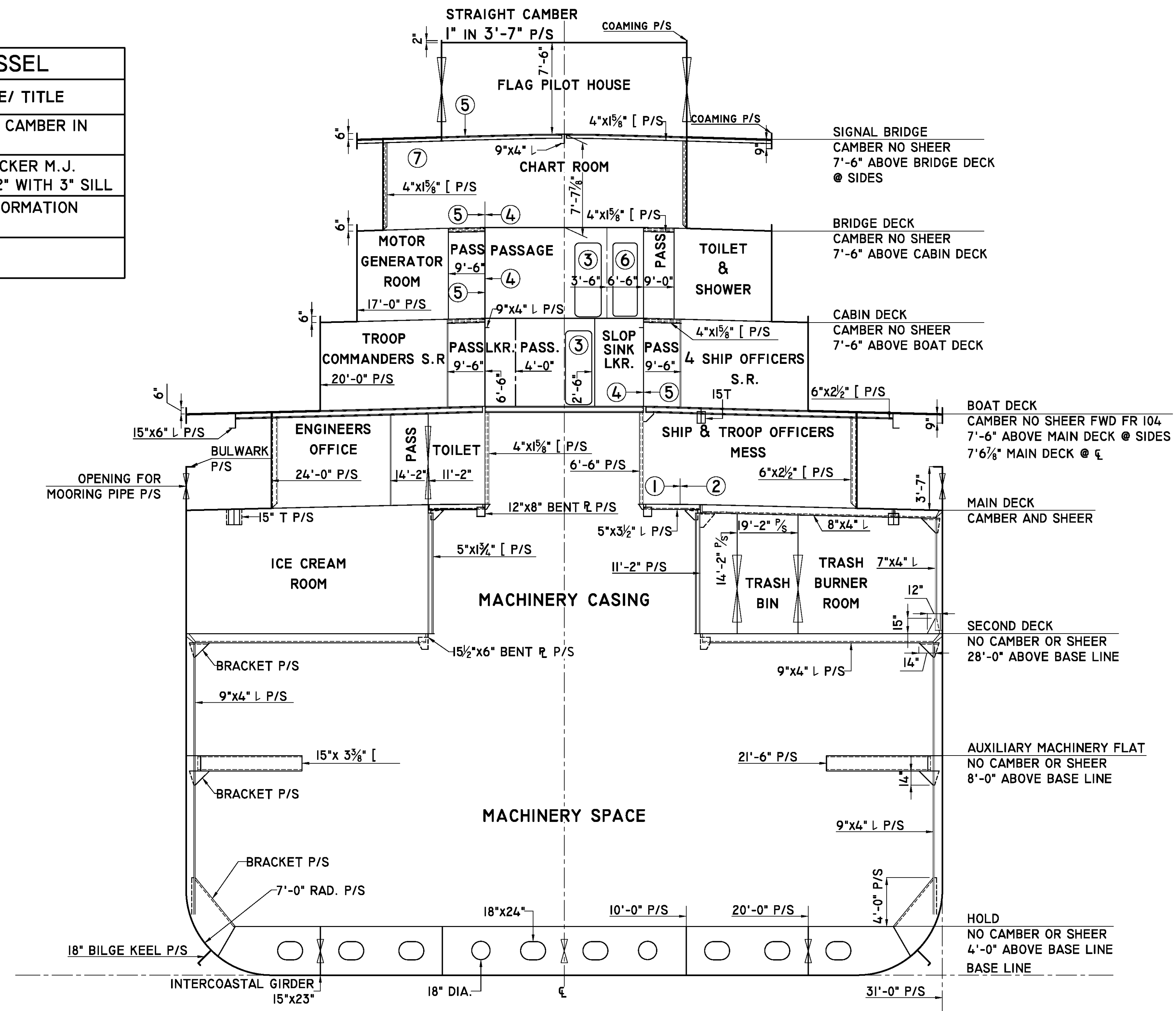

MID-SHIP SECTION
AT FRAME 81 LOOKING FORWARD

NOTE: DRAWINGS TRACED FROM SCANS OF ORIGINAL DESIGN DRAWINGS (BUREAU OF SHIPS PLAN No. APA236-S0103-609030)

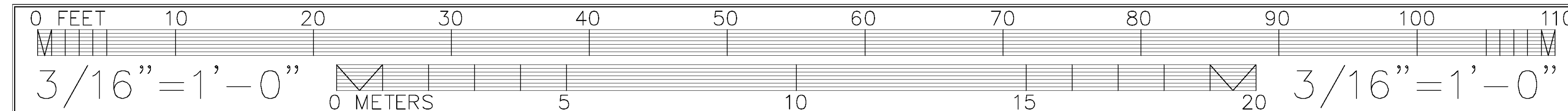

USS GAGE (APA-168)
JAMES RIVER RESERVE FLEET
NEWPORT NEWS COUNTY

NEWPORT NEWS VICINITY

HAER MARITIME RECORDING PROJECT
NATIONAL PARK SERVICE
UNITED STATES DEPARTMENT OF THE INTERIOR

SCANNED FROM HISTORIC DRAWINGS AND REFORMATTED BY: ASHLEY T. WALKER, 2009

HISTORIC AMERICAN ENGINEERING RECORD
INDEX NUMBER
VA-133

SHEET
VIRGINIA 10 OF 11

IF REPRODUCED, PLEASE CREDIT THE HISTORIC AMERICAN ENGINEERING RECORD, NATIONAL PARK SERVICE, NAME OF DELINEATOR, DATE OF DRAWING

USS Gage

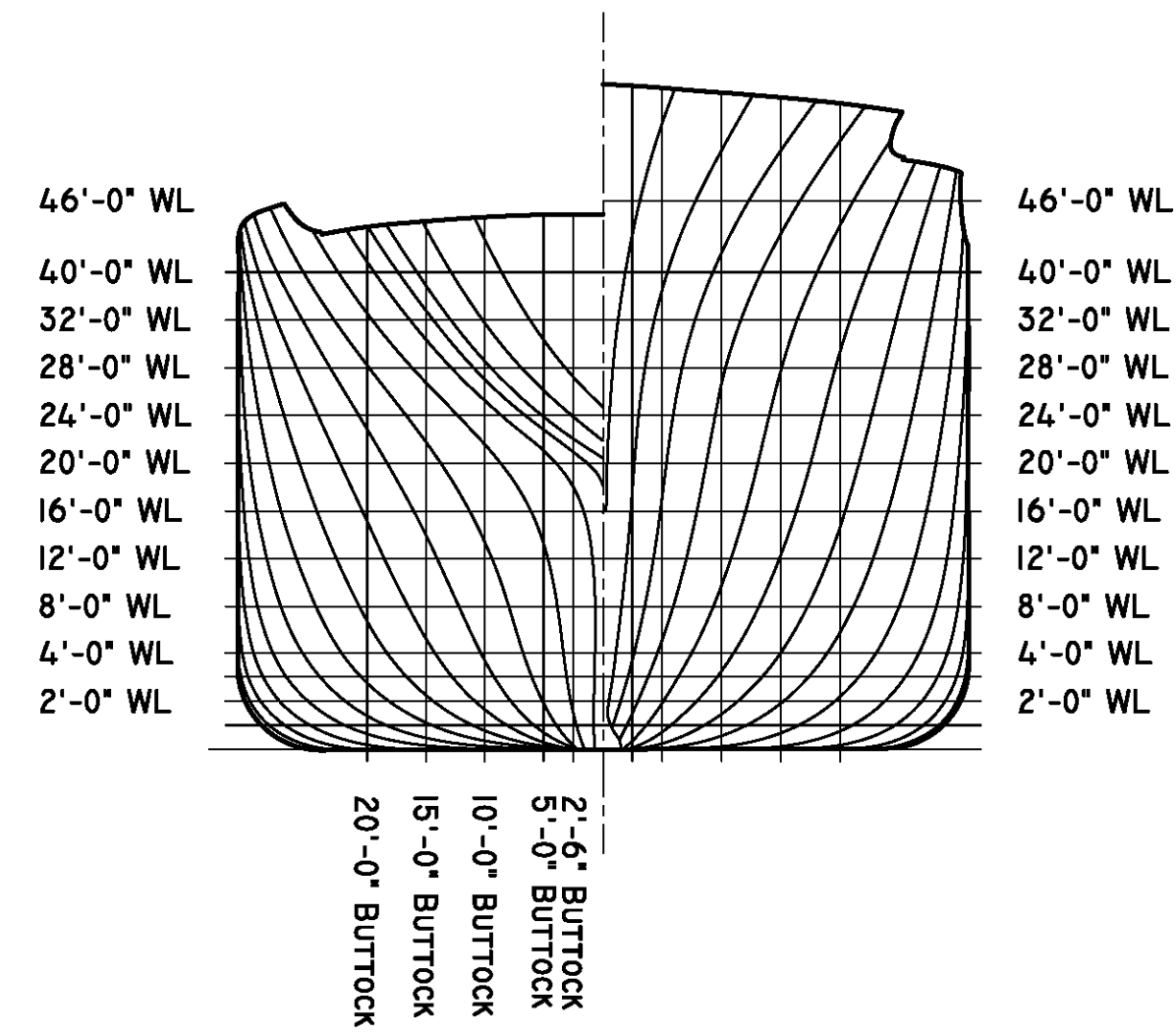
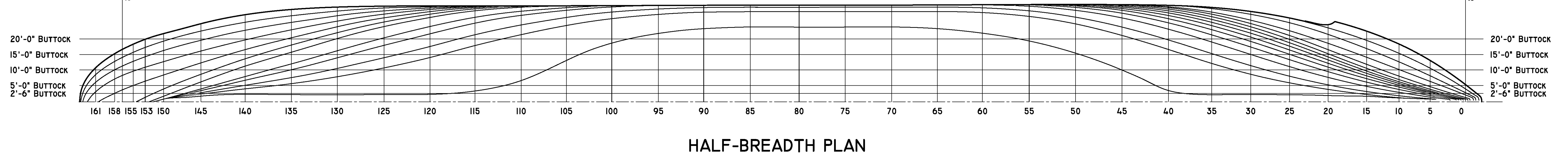
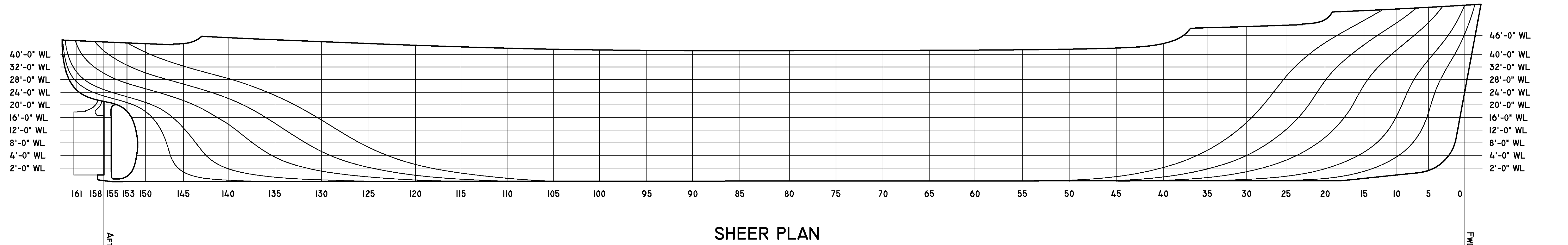

NOTE: DRAWINGS TRACED FROM SCANS OF ORIGINAL DESIGN DRAWINGS (U.S.M.C PLAN No. MCV-SAP2-S5-0-9)

