

**FIGURES**

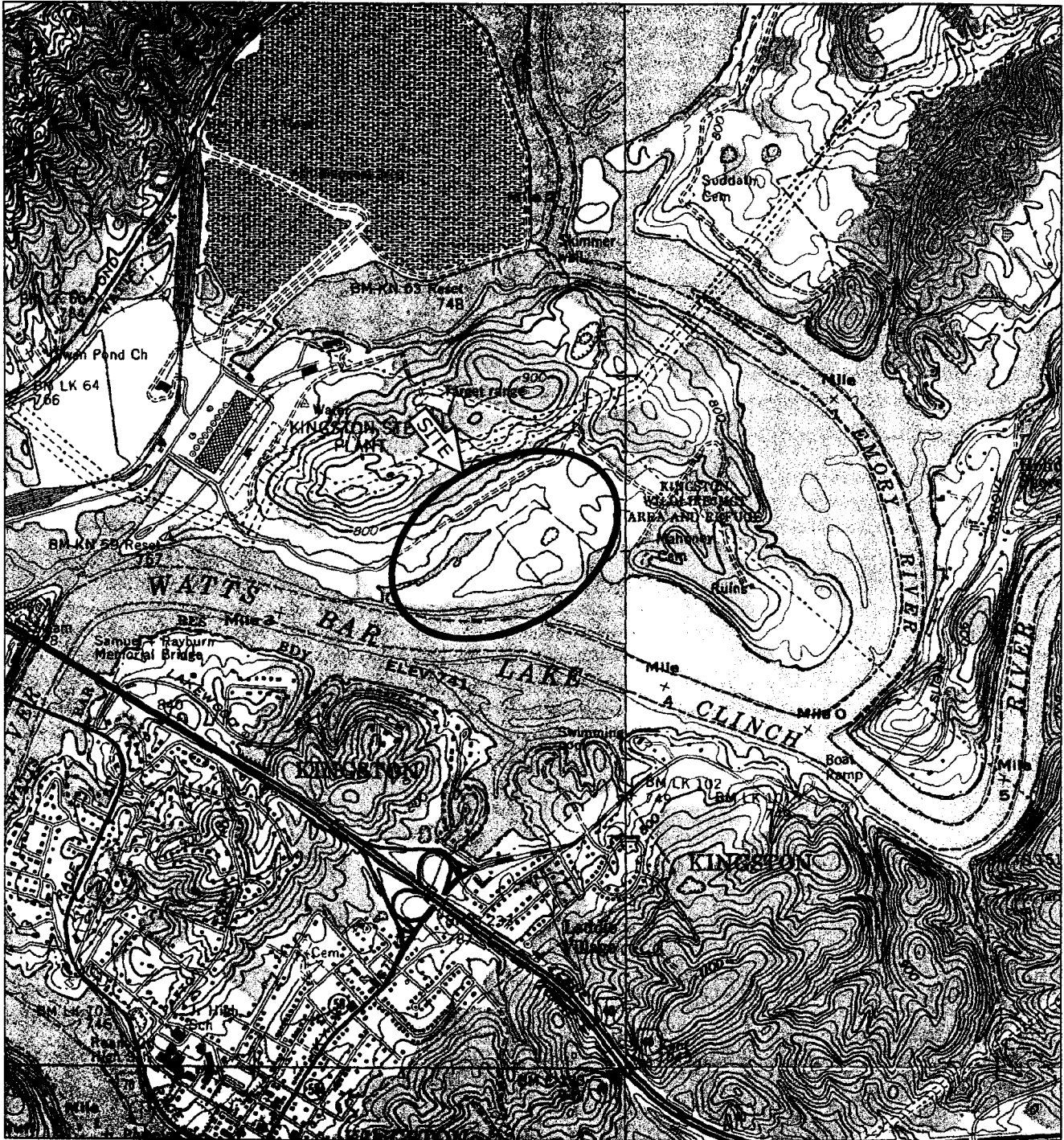

SOURCE: USGS TOPOGRAPHIC MAPS OF HARRIMAN AND ELVERTON, TN QUADRANGLES



MACTEC Engineering and Consulting, Inc.  
 1725 Louisville Drive  
 Knoxville, Tennessee 37921-5904  
 865-588-8544 • Fax: 865-588-8026

**FIGURE 1: SITE LOCATION MAP  
 PROPOSED GYPSUM DISPOSAL AREA -  
 ADDITIONAL GEOTECHNICAL  
 KINGSTON, TENNESSEE**

DRAFTING BY: *[Signature]*  
 JOB NUMBER:  
 3043051064/0001

PREPARED BY: *[Signature]*  
 DATE:  
 DECEMBER 22, 2005

CHECKED BY: *[Signature]*  
 SCALE:  
 0 2000'

COORDINATES: N 35°53'39"  
 W 84°31'13"

3043051064.dwg Thu. 22 Dec 2005 - 4:06pm REVERENC

3043051064\_01\_FIG2 Thu, 19 Jan 2006 - 9:45am REVERENC

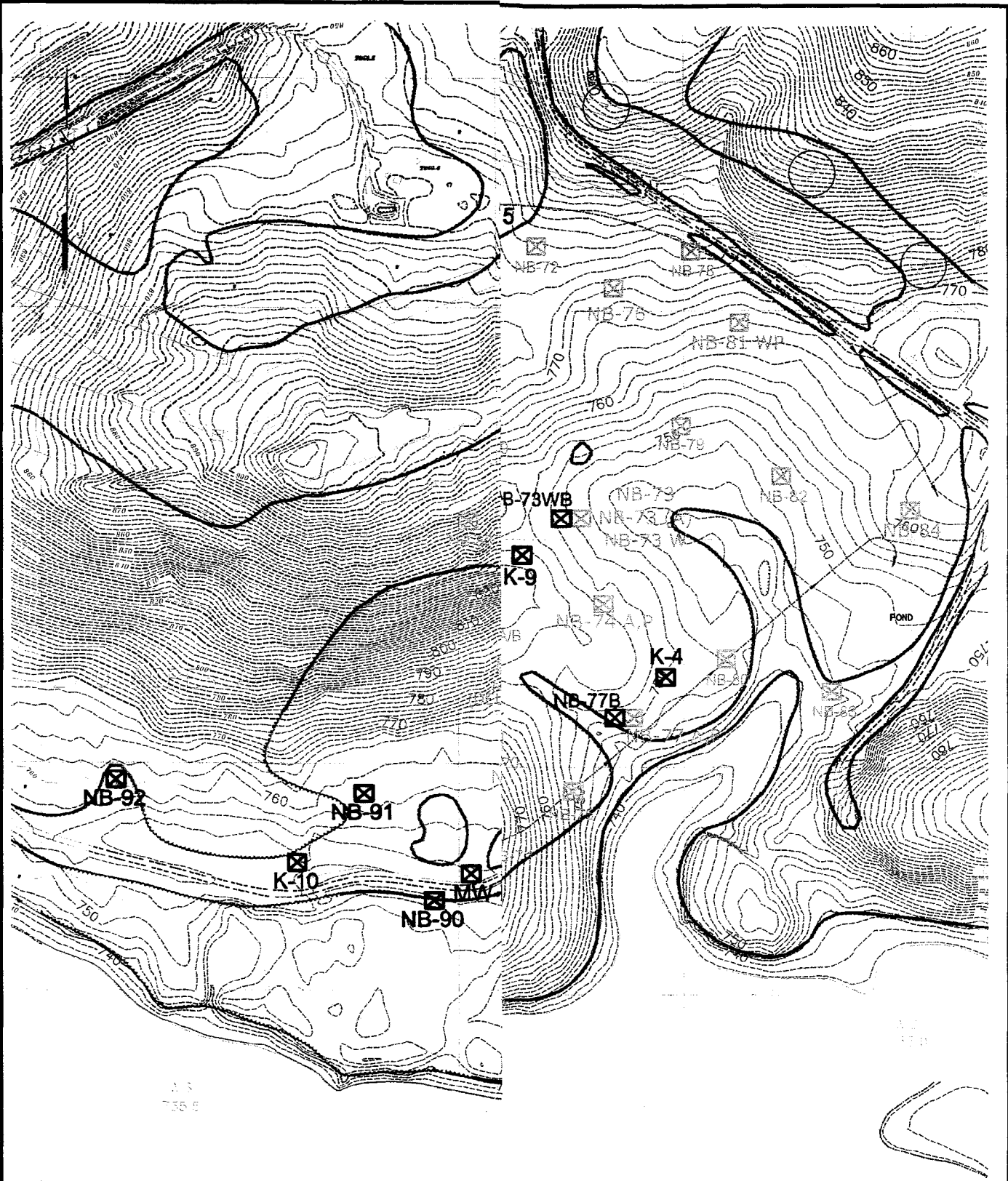

<b>LEC 2: BORING LOCATION PLAN</b> <b>ED GYPSUM DISPOSAL AREA -</b> <b>IONAL GEOTECHNICAL</b> <b>ON, TENNESSEE</b>			COORDINATES: N XX°XX'XX" W XX°XX'XX"
[Symbol] NB-2 [Symbol] MW- [Symbol] NB-2	PREPARED BY: <i>CTJ</i> DATE: 4/0001	CHECKED BY: <i>ASD</i> SCALE: 0 300'	
[Symbol] K-1 [Symbol] K-4 [Symbol] K-9 [Symbol] K-10 [Symbol] MVA [Symbol] NB-72 [Symbol] NB-75 [Symbol] NB-78 [Symbol] NB-81-WP [Symbol] NB-79 [Symbol] NB-82 [Symbol] NB-73WB [Symbol] NB-73 [Symbol] NB-73-M [Symbol] NB-77B [Symbol] NB-92 [Symbol] NB-91 [Symbol] NB-90			
[Symbol] 5 [Symbol] FOND			

**APPENDIX A**

**FIELD EXPLORATORY PROCEDURES**

## **FIELD EXPLORATORY PROCEDURES**

### **Soil Test Boring (Hollow Stem)**

All boring and sampling operations were conducted in general accordance with ASTM D 1586. The borings were advanced by mechanically twisting continuous steel hollow-stem auger flights into the ground. At regular intervals, soil samples were obtained with a standard 1.4-inch I.D., 2-inch O.D., split-tube sampler. The sampler was first seated six inches to penetrate any loose cuttings and then driven an additional foot with blows of a 140-pound hammer falling 30 inches. The number of hammer blows required to drive the sampler the final foot of penetration was recorded and is designated the "standard penetration resistance (SPT)". Proper evaluation of the penetration resistance provides an index to the soil's strength, density, and ability to support foundations.

Representative portions of the soil samples obtained from the split-tube sampler were sealed in glass jars and transported to our laboratory, where they were examined by our engineer to verify the driller's field classifications. Test Boring Records are attached, graphically showing the soil descriptions and penetration resistances.

### **Undisturbed Sampling**

The relatively undisturbed samples were obtained by pushing a section of 3-inch O.D., 16-gauge steel tubing into the soil at the desired sampling level. The sampling was performed in general accordance with ASTM D-1587. The tube, together with the encased soils, was carefully removed from the ground, made airtight, and transported to our laboratory.

### **Boring Backfill**

The borings were backfilled to the ground surface with cement grout. The owner is advised that, even with this backfill technique, there is the possibility of future borehole subsidence depending on actual subsurface conditions, surface drainage, etc. The property owner should monitor the boring locations over time to discover subsidence and make the necessary repairs.

## Rock Coring

Prior to coring, casing is set in the hole drilled through the overburden soils, if necessary, to keep the hole from caving. Refusal materials are then cored according to ASTM D 2113, using a diamond-studded bit fastened to the end of a hollow, double-tube core barrel. This device is rotated at high speeds, and the cuttings are brought to the surface by circulating water. Core samples of the material penetrated are protected and retained in the swivel-mounted inner tube. Upon completion of each core run, the core barrel is brought to the surface, the core recovery is measured, the samples are removed, and the core is placed in boxes for transportation and storage.

The core samples are returned to the laboratory where the refusal material is identified, and the percent core recovery and rock quality designation are determined by a soils engineer or geologist. The percent core recovery is the ratio of the sample length obtained to the depth drilled, expressed as a percent. The rock quality designation (RQD) is obtained by summing up the length of core recovered, including only the pieces of core that are 4 inches or longer, and divided by the total length drilled. The percent core recovery and RQD are related to the soundness and continuity of the refusal material. Refusal material descriptions, recoveries, and the bit size used are shown on the "Test Boring Records."

The NQ and HQ sizes designate bits that obtain rock cores 1-7/8 and 2-1/2 inches in diameter, respectively.

**APPENDIX B**

**KEY TO SYMBOLS AND DESCRIPTIONS**

**SOIL TEST BORING RECORDS**

GROUP SYMBOLS	TYPICAL NAMES	GROUP SYMBOLS	TYPICAL NAMES	Undisturbed Sample 1.5-2.0 = Recovered (ft) / Pushed (ft)	
	TOP SOIL		CONCRETE	Split Spoon Sample	
				Rock Core 60-100 = RQD / Recovery	
	ASPHALT		DOLOMITE	No Sample	
				Rotary Drill	
	GRAVEL		LIMESTONE	Water Table at time of drilling	
	FILL		SHALE		
	SUBSOIL		LIMESTONE/SHALE - Limestone with shale interbeds		
	ALLUVIUM		SANDSTONE		
	COLLUVIUM		SILTSTONE		
	RESIDUUM - Soft to firm		AUGER BORING		
	RESIDUUM - Stiff to very hard		UNDISTURBED SAMPLE ATTEMPT		

Correlation of Penetration Resistance  
with Relative Density and Consistency

SAND & GRAVEL		SILT & CLAY	
No. of Blows	Relative Density	No. of Blows	Consistency
0 - 4	Very Loose	0 - 2	Very Soft
5 - 10	Loose	3 - 4	Soft
11 - 20	Firm	5 - 8	Firm
21 - 30	Very Firm	9 - 15	Stiff
31 - 50	Dense	16 - 30	Very Stiff
Over 50	Very Dense	31 - 50	Hard
		Over 50	Very Hard

**BOUNDARY CLASSIFICATIONS:** Soils possessing characteristics of two groups are designated by combinations of group symbols.

SILT OR CLAY	SAND			GRAVEL		Cobbles	Boulders
	Fine	Medium	Coarse	Fine	Coarse		
	No.200	No.40	No.10	No.4	3/4"	3"	12"

U.S. STANDARD SIEVE SIZE

## KEY TO SYMBOLS AND DESCRIPTIONS



MACTEC Engineering and Consulting of Georgia, Inc.  
1725 Louisville Drive  
Knoxville, Tennessee 37921-5904  
865-588-8544 • Fax: 865-588-8026

**Reference:** The Unified Soil Classification System, Corps of Engineers, U.S. Army Technical Memorandum No. 3-357, Vol. 1, March, 1953 (Revised April, 1960)

TVA-00021558



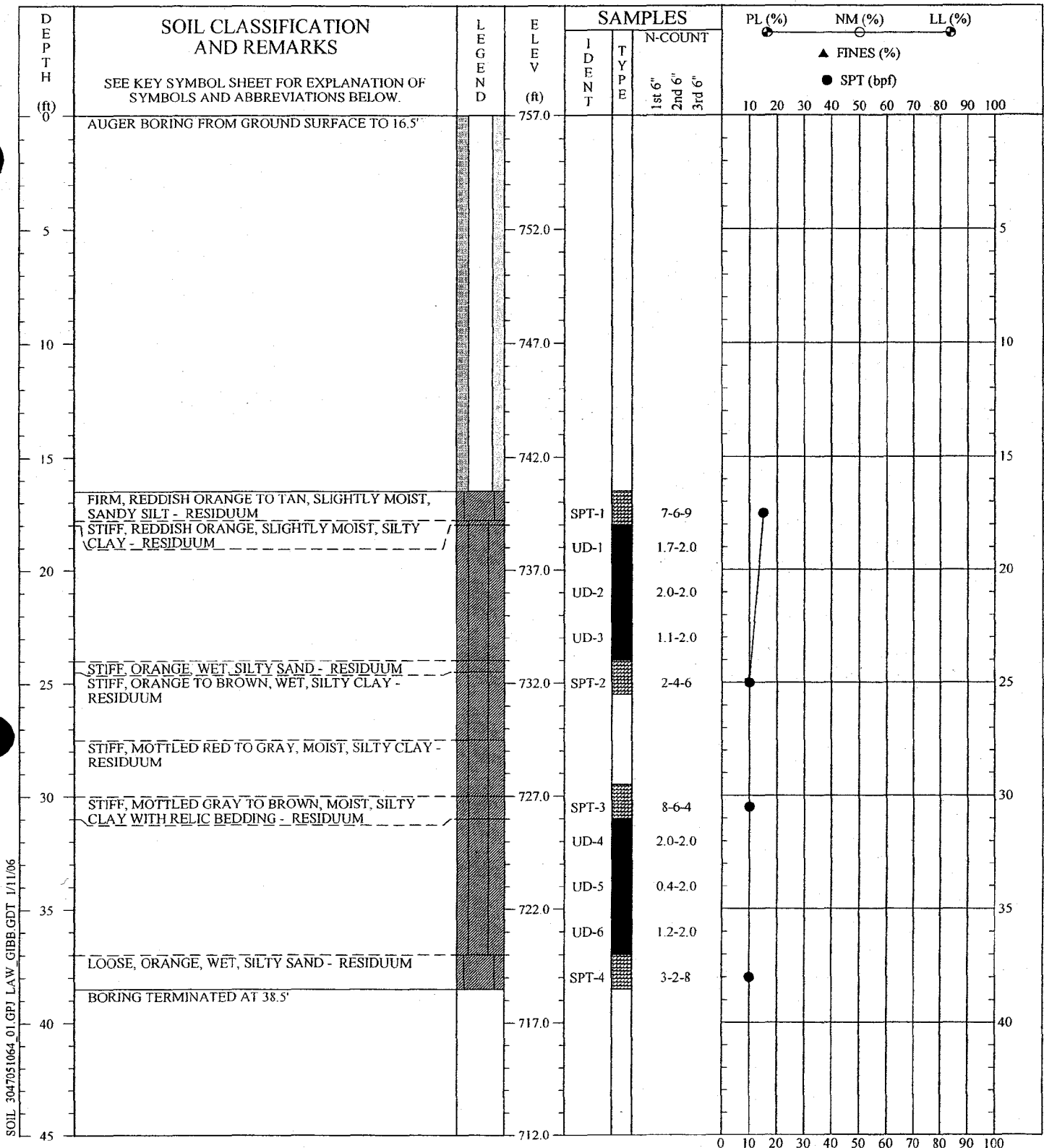

SOIL 3047051064 01.GPJ LAW GIBB.GDT 1/11/06

REMARKS: STANDARD PENETRATION RESISTANCE TESTING PERFORMED USING AN AUTOMATIC HAMMER. NO GROUND WATER ENCOUNTERED AT TIME OF EXPLORATION.

**SOIL TEST BORING RECORD**

**PROJECT:** TVA Kingston  
**DRILLED:** November 11, 2005      **BORING NO.:** NB-21B  
**PROJ. NO.:** 3043051064/0001      **PAGE 1 OF 1**

THIS RECORD IS A REASONABLE INTERPRETATION OF SUBSURFACE CONDITIONS AT THE EXPLORATION LOCATION. SUBSURFACE CONDITIONS AT OTHER LOCATIONS AND AT OTHER TIMES MAY DIFFER. INTERFACES BETWEEN STRATA ARE APPROXIMATE. TRANSITIONS BETWEEN STRATA MAY BE GRADUAL.

Driller: Marshall  
 Prepared By: M.O.  
 Checked By: *[Signature]*



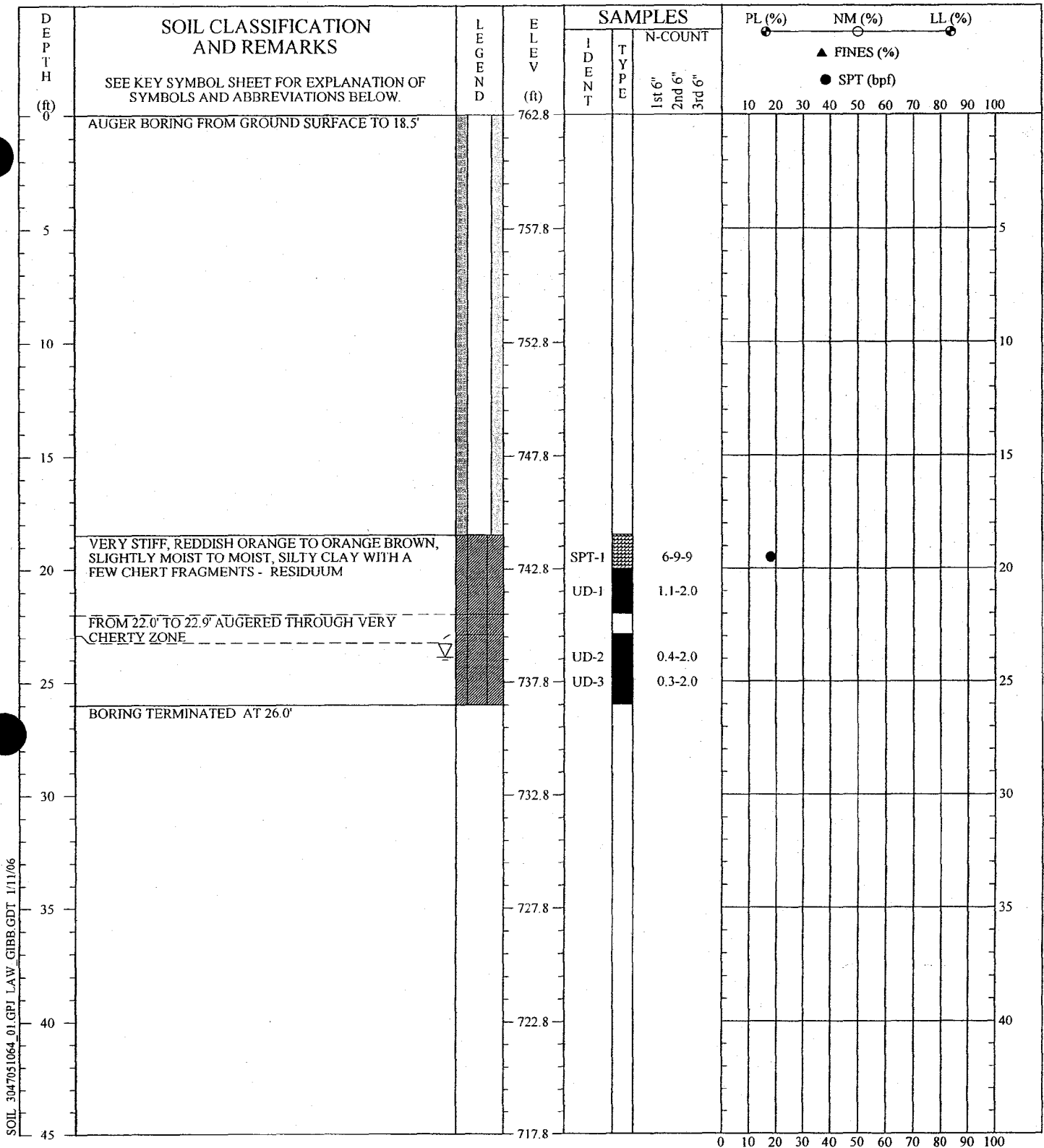

SOIL 3047051064 01.GPJ LAW\_GIBB.GDT 1/11/06

REMARKS: STANDARD PENETRATION RESISTANCE TESTING PERFORMED USING AN AUTOMATIC HAMMER BORING NB-47B WAS DRILLED APPROXIMATELY 14 FEET S 75°W OF MW-47.

**SOIL TEST BORING RECORD**

**PROJECT:** TVA Kingston  
**DRILLED:** November 10, 2005      **BORING NO.:** NB-47B  
**PROJ. NO.:** 3043051064/0001      **PAGE 1 OF 1**

THIS RECORD IS A REASONABLE INTERPRETATION OF SUBSURFACE CONDITIONS AT THE EXPLORATION LOCATION. SUBSURFACE CONDITIONS AT OTHER LOCATIONS AND AT OTHER TIMES MAY DIFFER. INTERFACES BETWEEN STRATA ARE APPROXIMATE. TRANSITIONS BETWEEN STRATA MAY BE GRADUAL.

Driller : Marshall  
 Prepared By: Justice  
 Checked By: *SAJ*



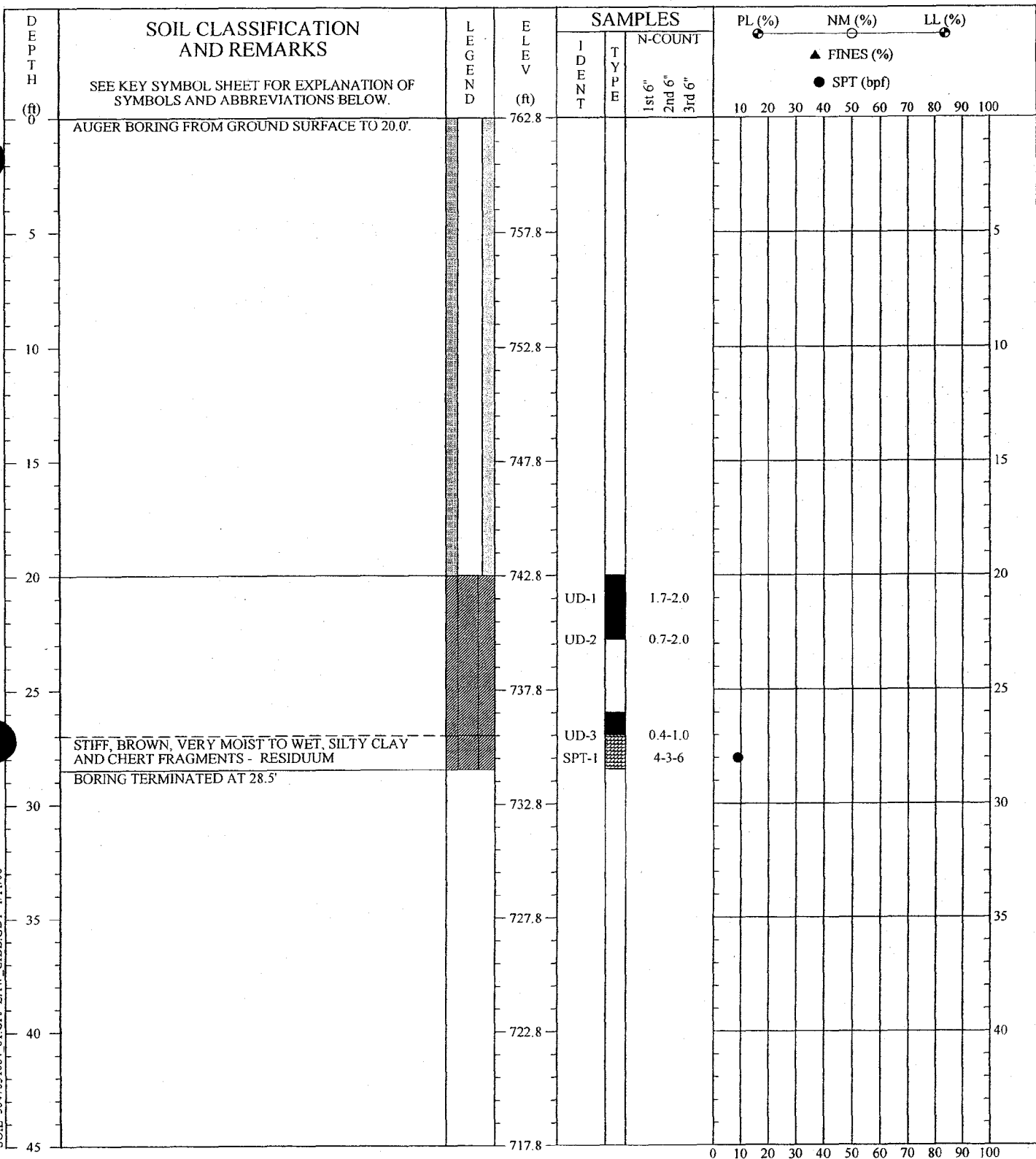

SOIL\_3047051064\_01.GPJ LAW\_GIBB.GDT 1/11/06

REMARKS: STANDARD PENETRATION RESISTANCE TESTING PERFORMED USING AN AUTOMATIC HAMMER. NO GROUND WATER ENCOUNTERED AT TIME OF EXPLORATION. BORING NB-47BA WAS DRILLED APPROXIMATELY 14 FEET S20°E OF MW-47.

THIS RECORD IS A REASONABLE INTERPRETATION OF SUBSURFACE CONDITIONS AT THE EXPLORATION LOCATION. SUBSURFACE CONDITIONS AT OTHER LOCATIONS AND AT OTHER TIMES MAY DIFFER. INTERFACES BETWEEN STRATA ARE APPROXIMATE. TRANSITIONS BETWEEN STRATA MAY BE GRADUAL.

Driller: Marshall  
Prepared By: Justice  
Checked By: *MS*

SOIL TEST BORING RECORD	
PROJECT: TVA Kingston	
DRILLED: November 10, 2005	BORING NO.: NB-47BA
PROJ. NO.: 3043051064/0001	PAGE 1 OF 1
	

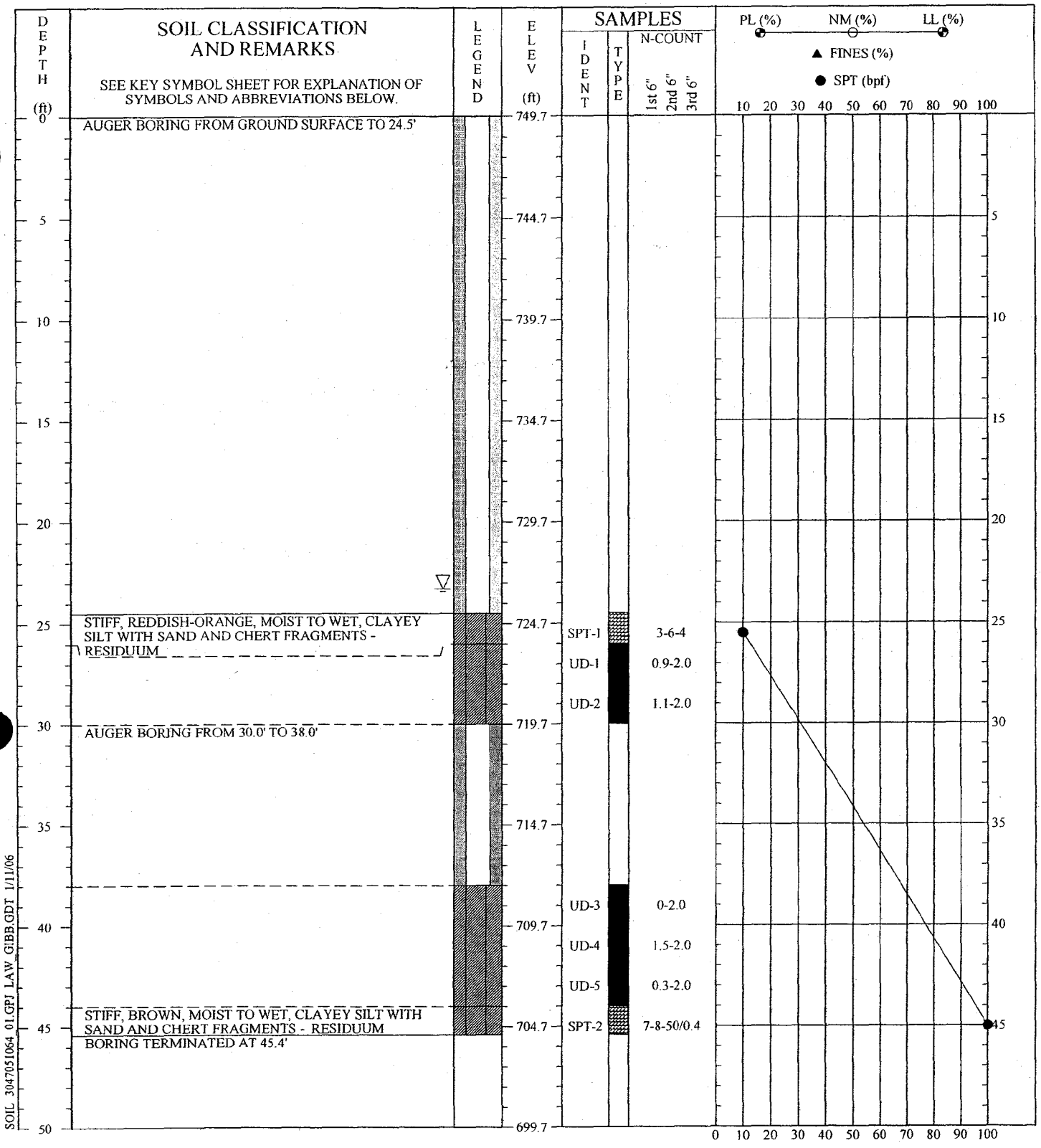

SOIL 3047051064 01.GPJ LAW\_GIBB.GDT 1/11/06

REMARKS: STANDARD PENETRATION RESISTANCE TESTING PERFORMED USING AN AUTOMATIC HAMMER.

**SOIL TEST BORING RECORD**

**PROJECT:** TVA Kingston  
**DRILLED:** November 10, 2005      **BORING NO.:** NB-73WB  
**PROJ. NO.:** 3043051064/0001      **PAGE 1 OF 1**

THIS RECORD IS A REASONABLE INTERPRETATION OF SUBSURFACE CONDITIONS AT THE EXPLORATION LOCATION. SUBSURFACE CONDITIONS AT OTHER LOCATIONS AND AT OTHER TIMES MAY DIFFER. INTERFACES BETWEEN STRATA ARE APPROXIMATE. TRANSITIONS BETWEEN STRATA MAY BE GRADUAL.

Driller : Marshall  
 Prepared By: Justice  
 Checked By: *[Signature]*



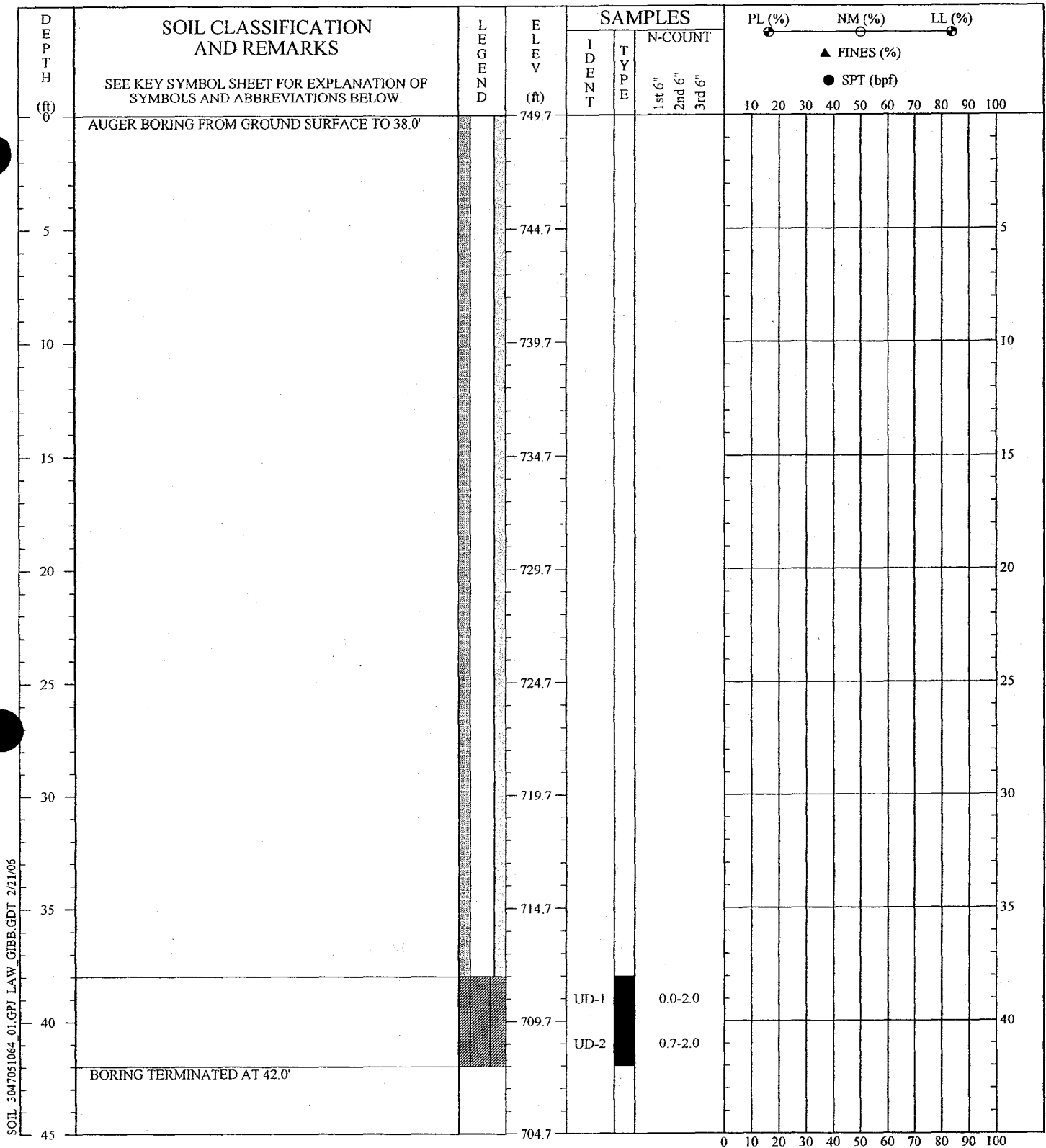

SOIL 3047051064\_01.GPJ LAW. GIBB.GDT 2/21/06

REMARKS: NO GROUND WATER ENCOUNTERED AT TIME OF EXPLORATION. BORING NB-73WBA WAS DRILLED APPROXIMATELY 8 FEET S30°E OF NB-73WB.

SOIL TEST BORING RECORD	
PROJECT: TVA Kingston	
DRILLED: November 10, 2005	BORING NO.: NB-73WBA
PROJ. NO.: 3043051064/0001	PAGE 1 OF 1
	

THIS RECORD IS A REASONABLE INTERPRETATION OF SUBSURFACE CONDITIONS AT THE EXPLORATION LOCATION. SUBSURFACE CONDITIONS AT OTHER LOCATIONS AND AT OTHER TIMES MAY DIFFER. INTERFACES BETWEEN STRATA ARE APPROXIMATE. TRANSITIONS BETWEEN STRATA MAY BE GRADUAL.

Driller: Marshall  
 Prepared By: Justice  
 Checked By: *SM*

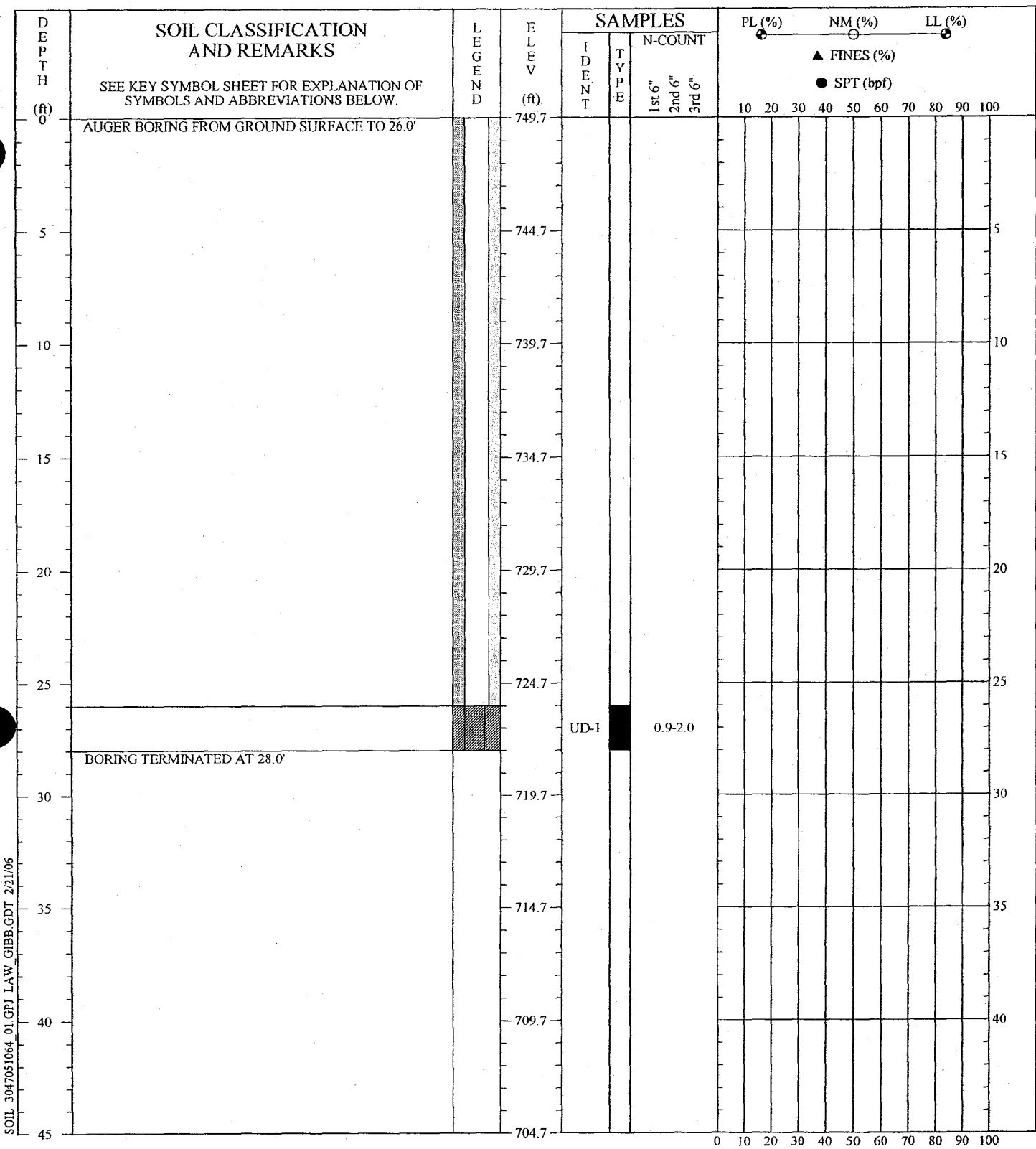

SOIL 3047051064\_01.GPJ LAW GIBB.GDT 2/21/06

REMARKS: NO GROUND WATER ENCOUNTERED AT TIME OF EXPLORATION.

THIS RECORD IS A REASONABLE INTERPRETATION OF SUBSURFACE CONDITIONS AT THE EXPLORATION LOCATION. SUBSURFACE CONDITIONS AT OTHER LOCATIONS AND AT OTHER TIMES MAY DIFFER. INTERFACES BETWEEN STRATA ARE APPROXIMATE. TRANSITIONS BETWEEN STRATA MAY BE GRADUAL.

Driller : Marshall  
 Prepared By: M.O.  
 Checked By: *ABJ*

**SOIL TEST BORING RECORD**

**PROJECT:** TVA Kingston  
**DRILLED:** November 11, 2005      **BORING NO.:** NB-73WBB  
**PROJ. NO.:** 3043051064/0001      **PAGE 1 OF 1**



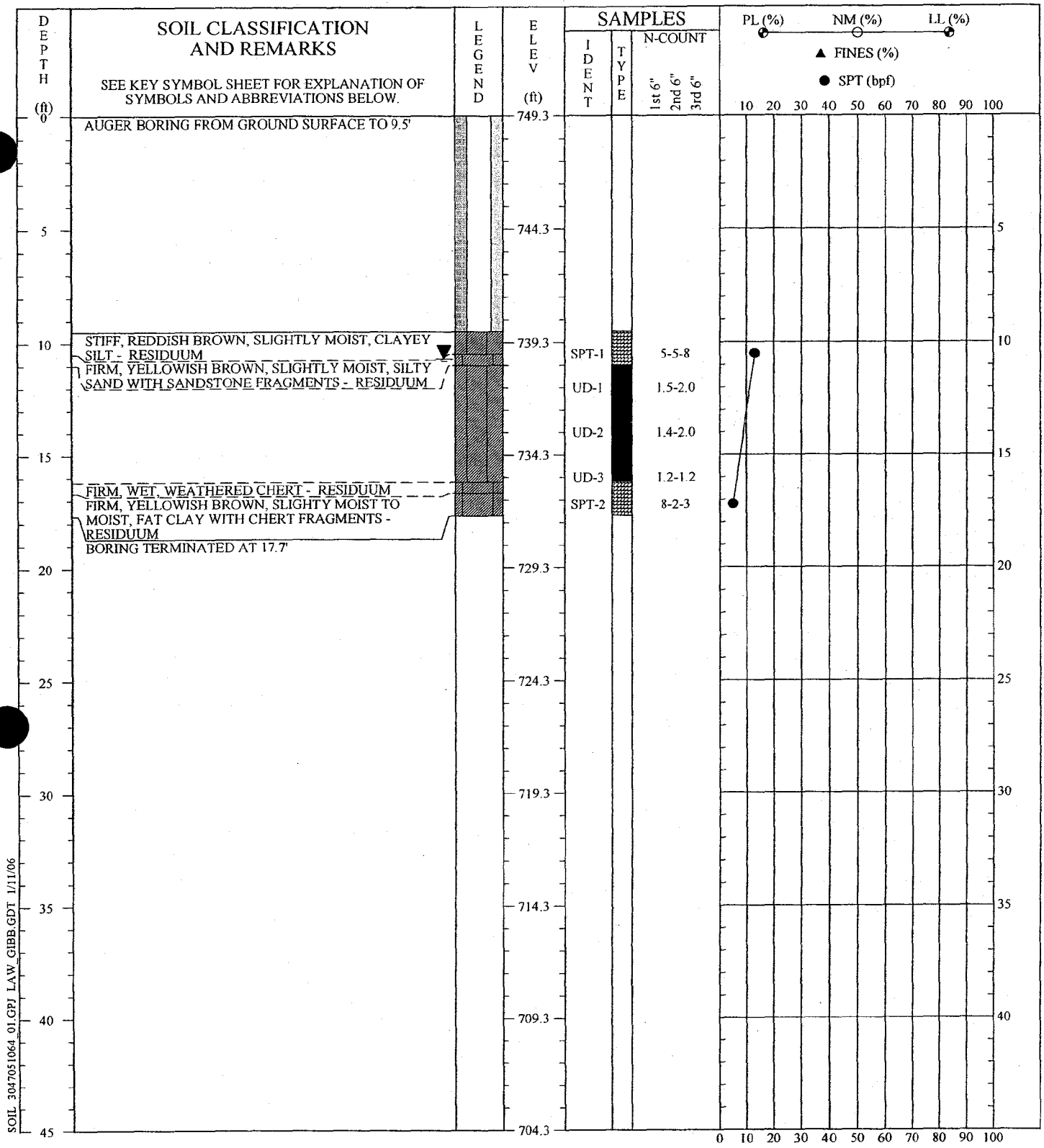

SOIL 3047051064\_01.GPJ LAW\_GIBB.GDT 1/11/06

REMARKS: STANDARD PENETRATION RESISTANCE TESTING PERFORMED USING AN AUTOMATIC HAMMER. GROUNDWATER MEASUREMENT WAS OBTAINED FROM MW-77. BORING NB-77B WAS DRILLED APPROXIMATELY 15 FEET N65°E OF MW-77.

THIS RECORD IS A REASONABLE INTERPRETATION OF SUBSURFACE CONDITIONS AT THE EXPLORATION LOCATION. SUBSURFACE CONDITIONS AT OTHER LOCATIONS AND AT OTHER TIMES MAY DIFFER. INTERFACES BETWEEN STRATA ARE APPROXIMATE. TRANSITIONS BETWEEN STRATA MAY BE GRADUAL.

Driller: Marshall  
Prepared By: Justice  
Checked By: *[Signature]*

SOIL TEST BORING RECORD	
PROJECT: TVA Kingston	BORING NO.: NB-77B
DRILLED: November 9, 2005	
PROJ. NO.: 3043051064/0001	PAGE 1 OF 1
	

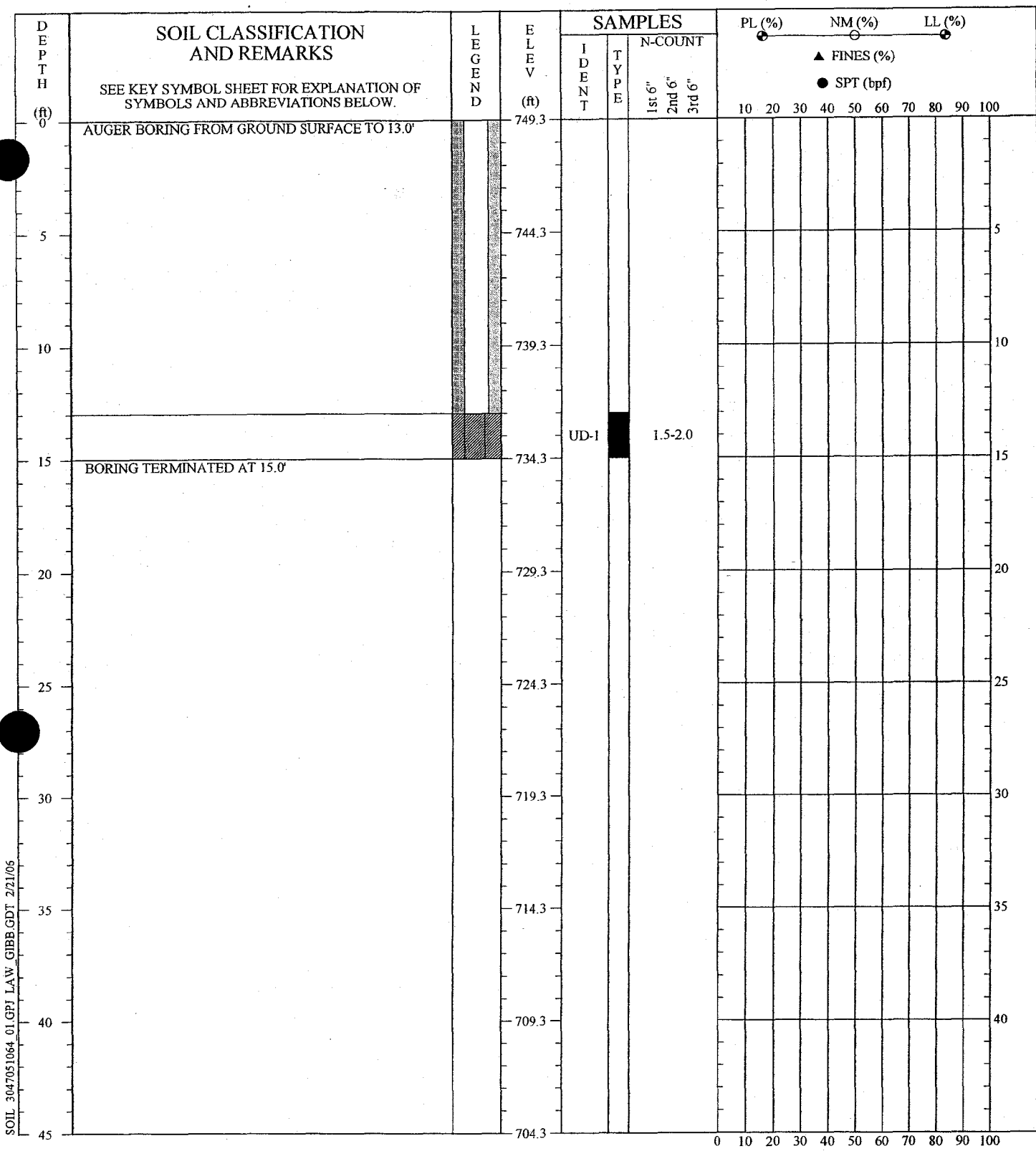

SOIL 3047051064 01.GPJ LAW\_GIBB.GDT 2/21/05

REMARKS: NO GROUND WATER ENCOUNTERED AT TIME OF EXPLORATION. BORING NB-77BA WAS DRILLED APPROXIMATELY 6 FEET N65°E OF NB-77B.

**SOIL TEST BORING RECORD**

**PROJECT:** TVA Kingston  
**DRILLED:** November 9, 2005      **BORING NO.:** NB-77BA  
**PROJ. NO.:** 3043051064/0001      **PAGE 1 OF 1**

THIS RECORD IS A REASONABLE INTERPRETATION OF SUBSURFACE CONDITIONS AT THE EXPLORATION LOCATION. SUBSURFACE CONDITIONS AT OTHER LOCATIONS AND AT OTHER TIMES MAY DIFFER. INTERFACES BETWEEN STRATA ARE APPROXIMATE. TRANSITIONS BETWEEN STRATA MAY BE GRADUAL.

Driller : Marshall  
 Prepared By: Justice  
 Checked By: *ADJ*





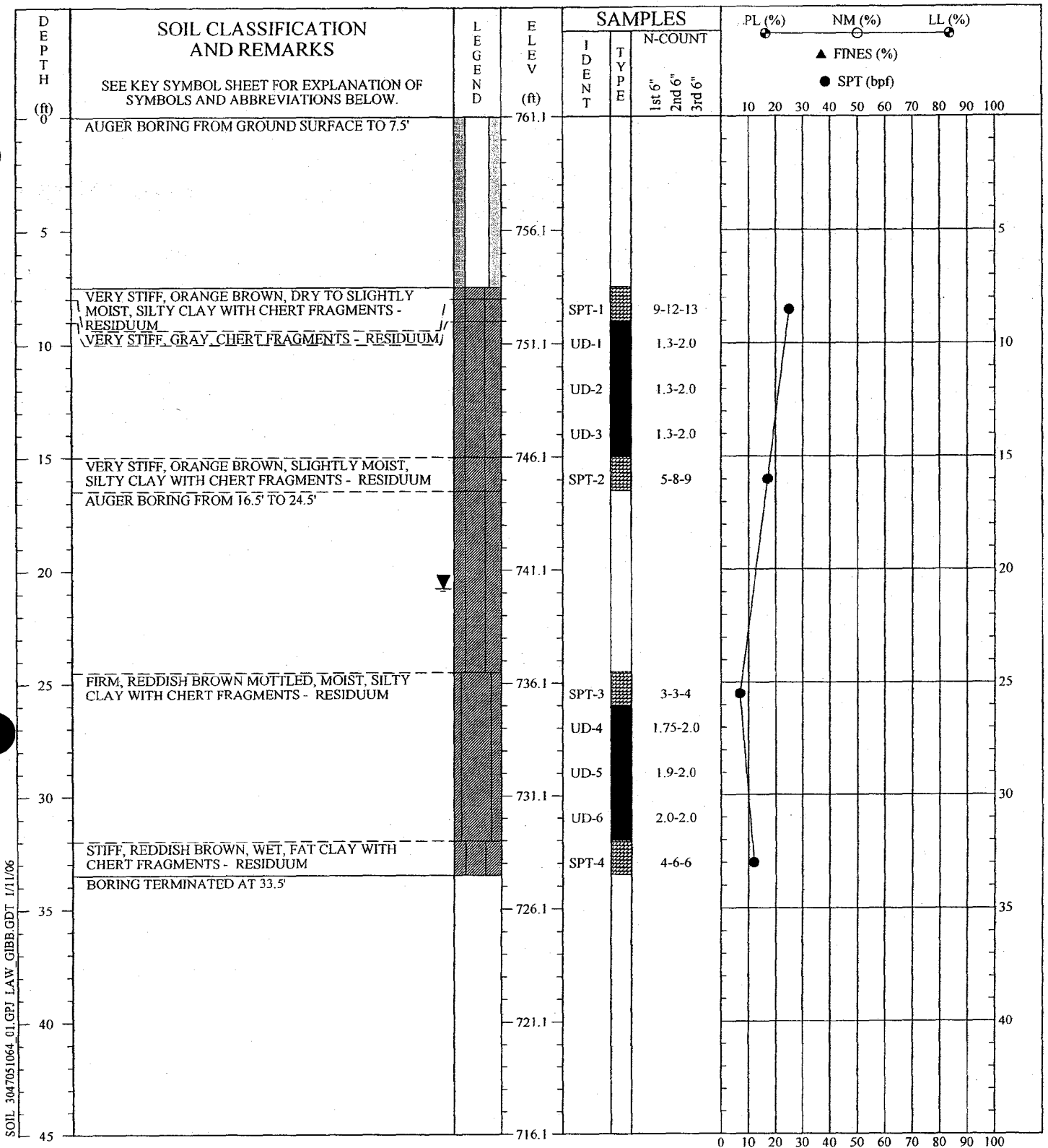

SOIL 3047051064 01.GPJ LAW GIBB.GDT 1/11/06

REMARKS: STANDARD PENETRATION RESISTANCE TESTING PERFORMED USING AN AUTOMATIC HAMMER.

THIS RECORD IS A REASONABLE INTERPRETATION OF SUBSURFACE CONDITIONS AT THE EXPLORATION LOCATION. SUBSURFACE CONDITIONS AT OTHER LOCATIONS AND AT OTHER TIMES MAY DIFFER. INTERFACES BETWEEN STRATA ARE APPROXIMATE. TRANSITIONS BETWEEN STRATA MAY BE GRADUAL.

Driller: Marshall  
Prepared By: M.O.  
Checked By: *MO*

SOIL TEST BORING RECORD	
PROJECT: TVA Kingston	BORING NO.: NB-85B
DRILLED: November 9, 2005	
PROJ. NO.: 3043051064/0001	PAGE 1 OF 1
	

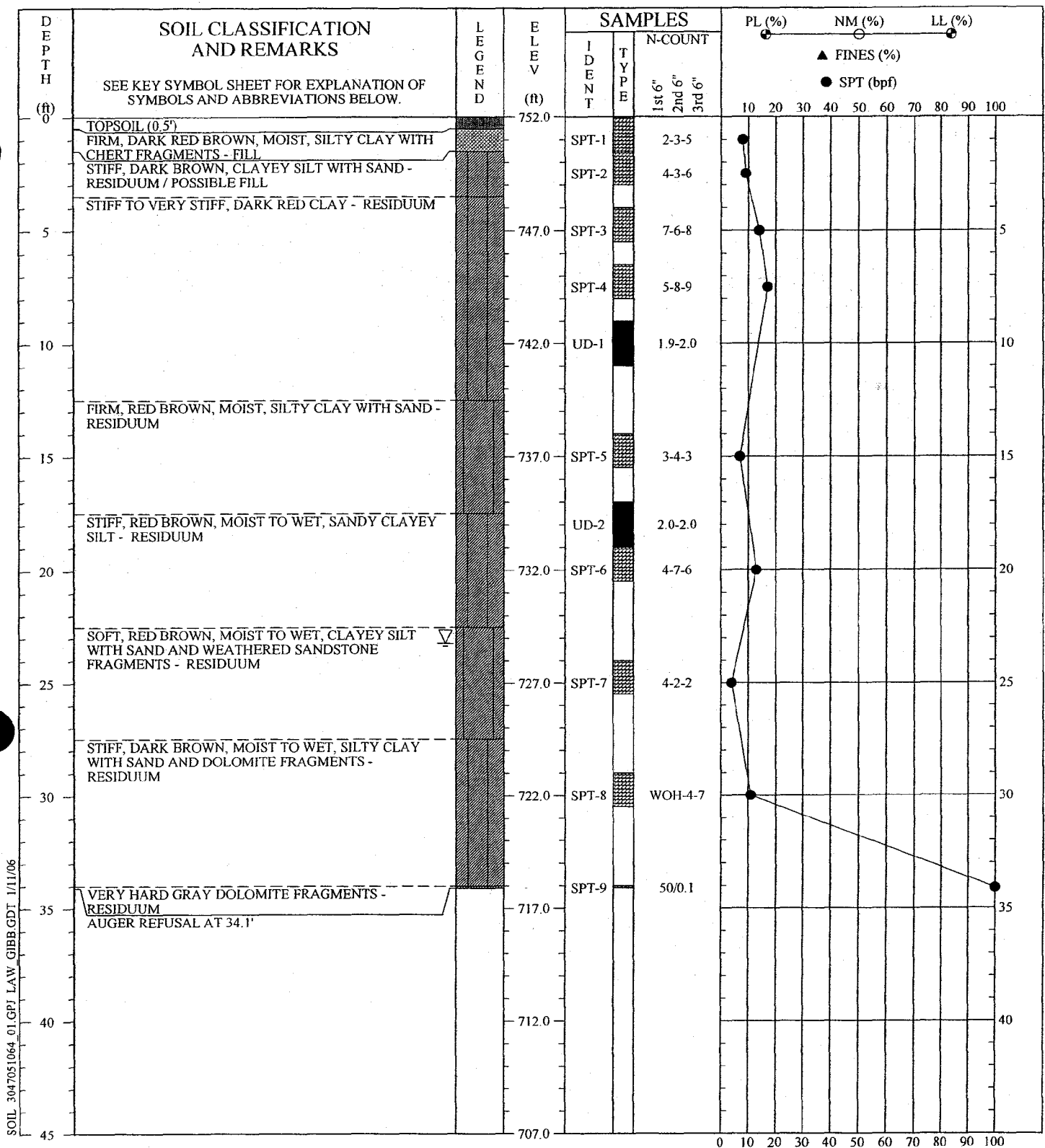

SOIL 3047051064 01.GPJ LAW. GIBB.GDT 11/11/06

REMARKS: STANDARD PENETRATION RESISTANCE TESTING PERFORMED USING AN AUTOMATIC HAMMER.

THIS RECORD IS A REASONABLE INTERPRETATION OF SUBSURFACE CONDITIONS AT THE EXPLORATION LOCATION. SUBSURFACE CONDITIONS AT OTHER LOCATIONS AND AT OTHER TIMES MAY DIFFER. INTERFACES BETWEEN STRATA ARE APPROXIMATE. TRANSITIONS BETWEEN STRATA MAY BE GRADUAL.

Driller: Warren  
Prepared By: Justice  
Checked By: *[Signature]*

SOIL TEST BORING RECORD	
PROJECT: TVA Kingston	
DRILLED: November 29, 2005	BORING NO.: NB-90
PROJ. NO.: 3043051064/0001	PAGE 1 OF 1
	

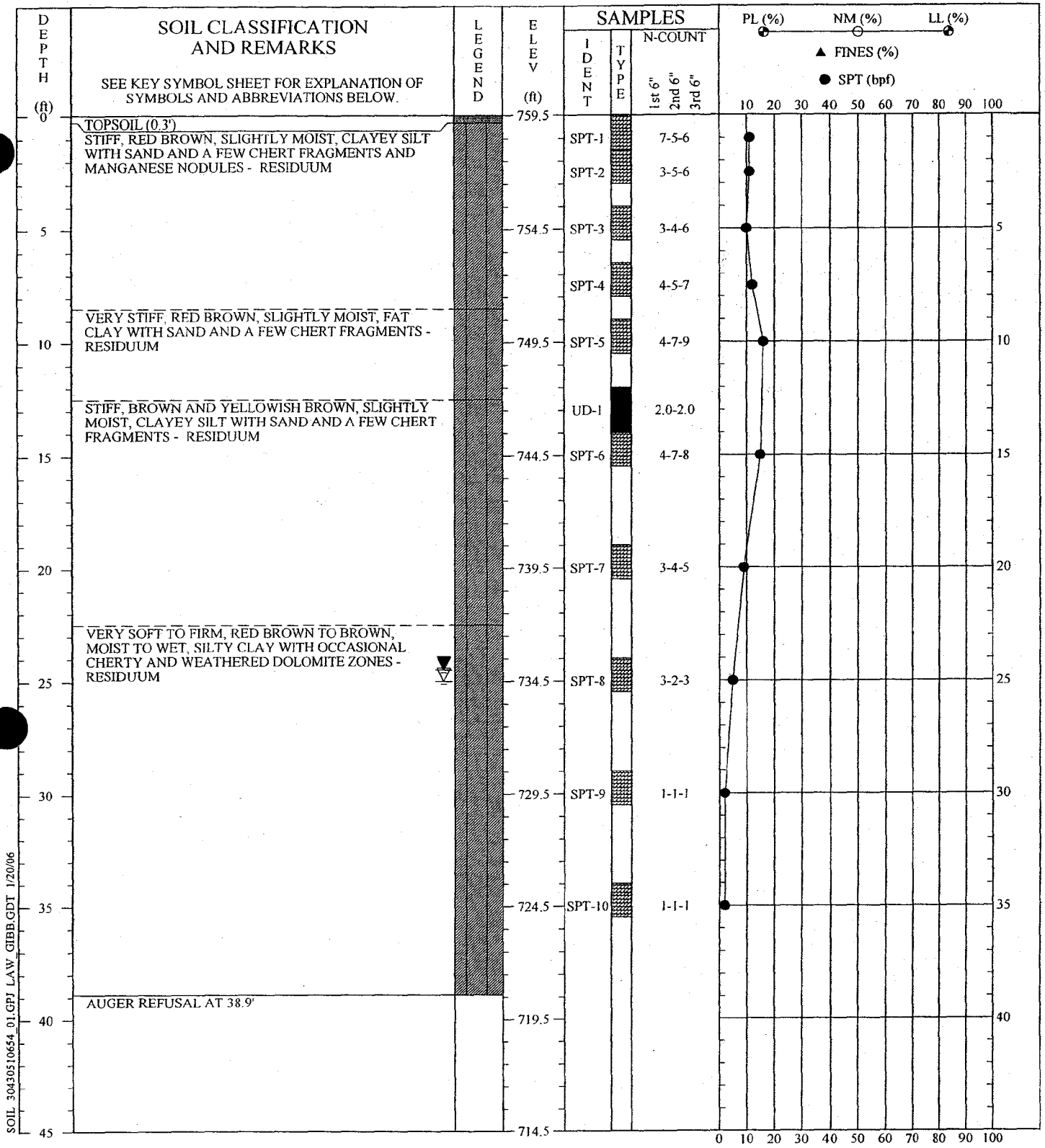

SOIL 30430510654 01.GPJ LAW GIBB/GDT 1/20/06

REMARKS: STANDARD PENETRATION RESISTANCE TESTING PERFORMED USING AN AUTOMATIC HAMMER.

THIS RECORD IS A REASONABLE INTERPRETATION OF SUBSURFACE CONDITIONS AT THE EXPLORATION LOCATION. SUBSURFACE CONDITIONS AT OTHER LOCATIONS AND AT OTHER TIMES MAY DIFFER. INTERFACES BETWEEN STRATA ARE APPROXIMATE. TRANSITIONS BETWEEN STRATA MAY BE GRADUAL.

Driller: Akins  
 Prepared By: Justice  
 Checked By: *[Signature]*

**SOIL TEST BORING RECORD**

PROJECT: TVA Kingston Additional Geotech  
 DRILLED: January 12, 2006 BORING NO.: NB-91  
 PROJ. NO.: 3043051064/0001 PAGE 1 OF 1



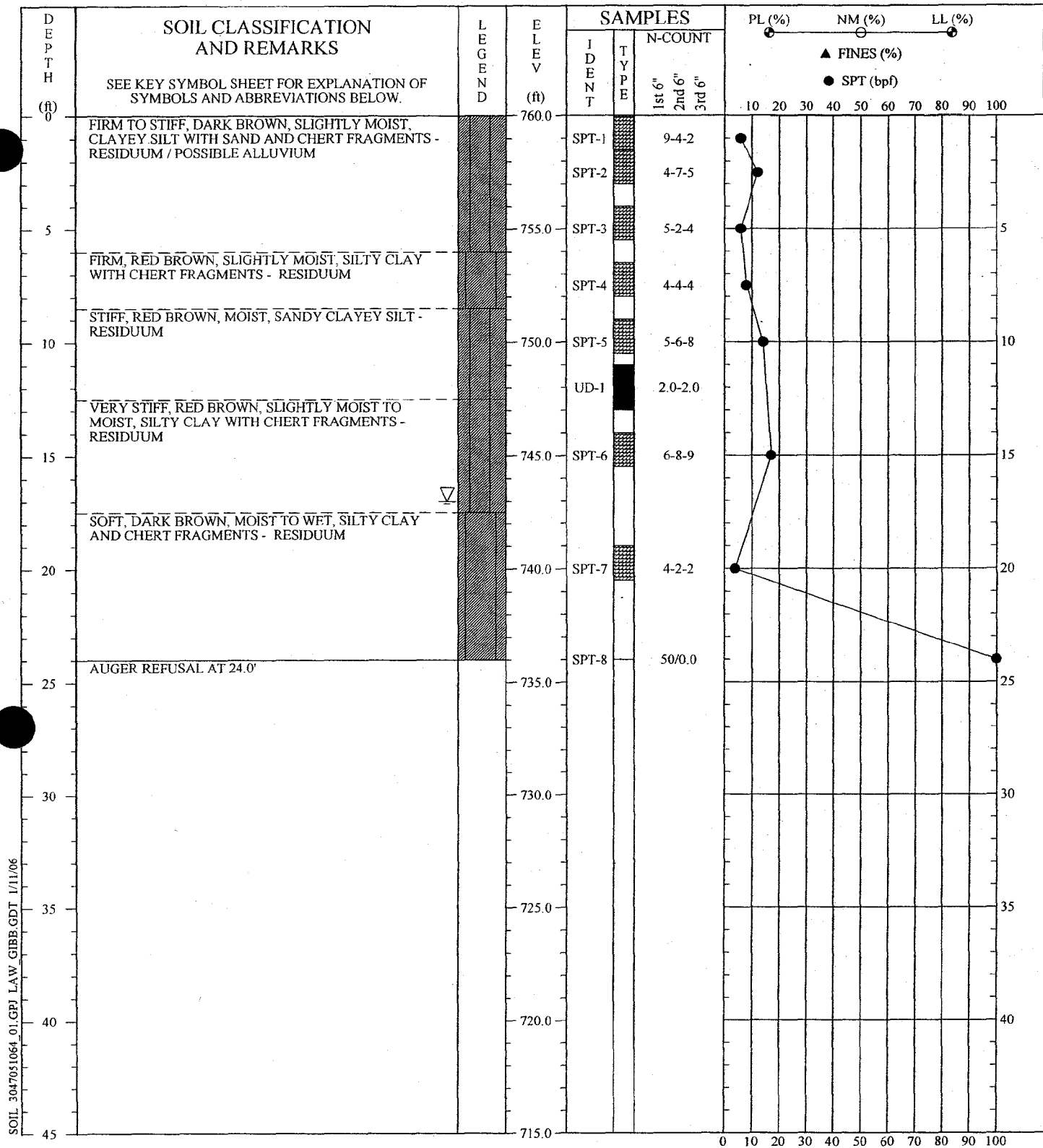

SOIL 3047051064\_01.GPJ LAW GIBB GDT 1/11/06

REMARKS: STANDARD PENETRATION RESISTANCE TESTING PERFORMED USING AN AUTOMATIC HAMMER.

THIS RECORD IS A REASONABLE INTERPRETATION OF SUBSURFACE CONDITIONS AT THE EXPLORATION LOCATION. SUBSURFACE CONDITIONS AT OTHER LOCATIONS AND AT OTHER TIMES MAY DIFFER. INTERFACES BETWEEN STRATA ARE APPROXIMATE. TRANSITIONS BETWEEN STRATA MAY BE GRADUAL.

Driller: Warren  
Prepared By: Justice  
Checked By: *[Signature]*

**SOIL TEST BORING RECORD**

**PROJECT:** TVA Kingston  
**DRILLED:** November 29, 2005      **BORING NO.:** NB-92  
**PROJ. NO.:** 3043051064/0001      **PAGE 1 OF 1**



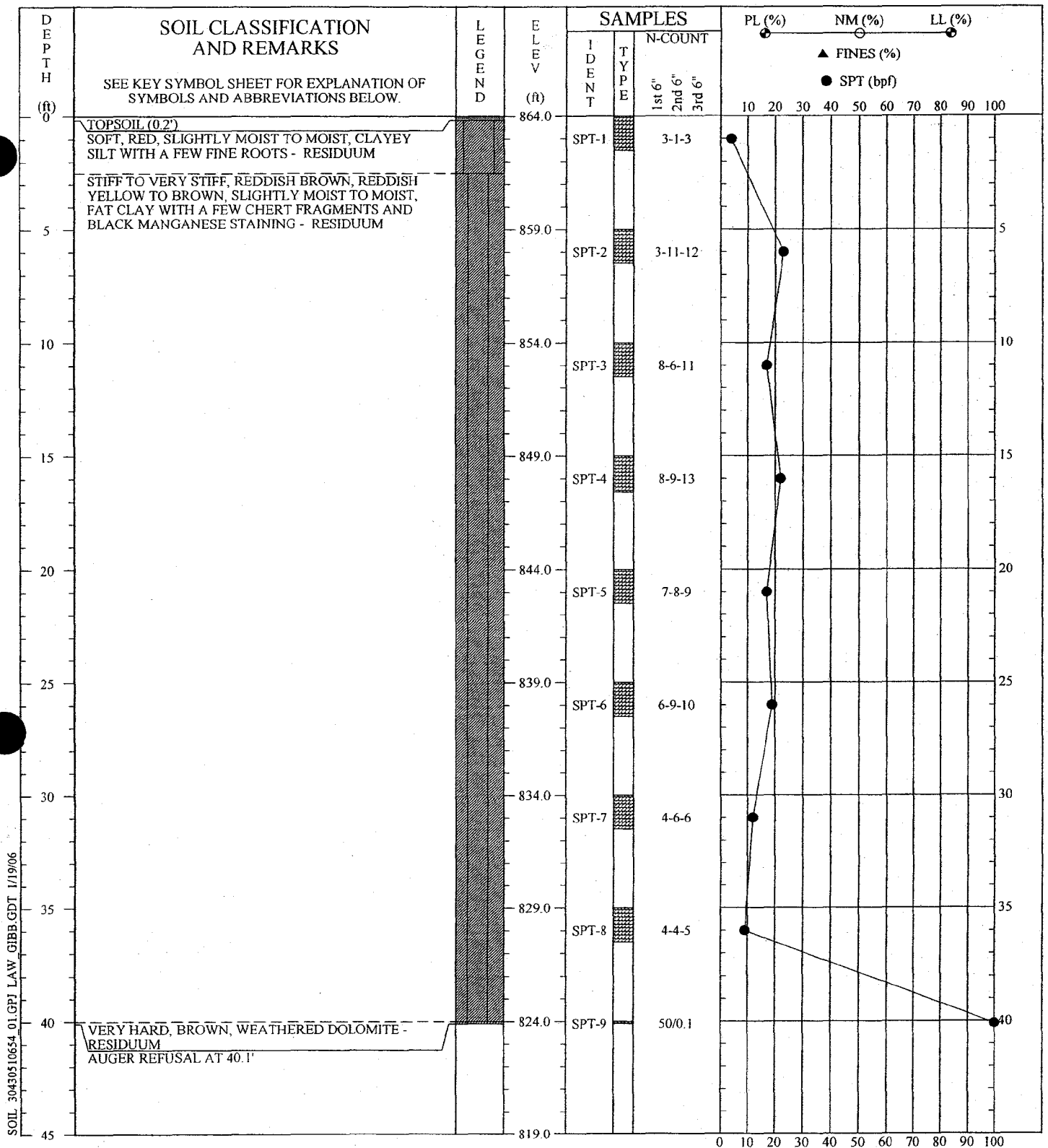

SOIL\_30430510654\_01.GPJ LAW\_GIBB.GDT 1/19/06

REMARKS: STANDARD PENETRATION RESISTANCE TESTING PERFORMED USING AN AUTOMATIC HAMMER. NO GROUND WATER ENCOUNTERED AT TIME OF EXPLORATION.

THIS RECORD IS A REASONABLE INTERPRETATION OF SUBSURFACE CONDITIONS AT THE EXPLORATION LOCATION. SUBSURFACE CONDITIONS AT OTHER LOCATIONS AND AT OTHER TIMES MAY DIFFER. INTERFACES BETWEEN STRATA ARE APPROXIMATE. TRANSITIONS BETWEEN STRATA MAY BE GRADUAL.

Driller : Akins  
Prepared By: Justice  
Checked By: *[Signature]*

SOIL TEST BORING RECORD	
<b>PROJECT:</b> TVA Kingston Additional Geotech	<b>BORING NO.:</b> NB-K
<b>DRILLED:</b> January 17, 2006	<b>PROJ. NO.:</b> 3043051064/0001
<b>PAGE 1 OF 1</b>	

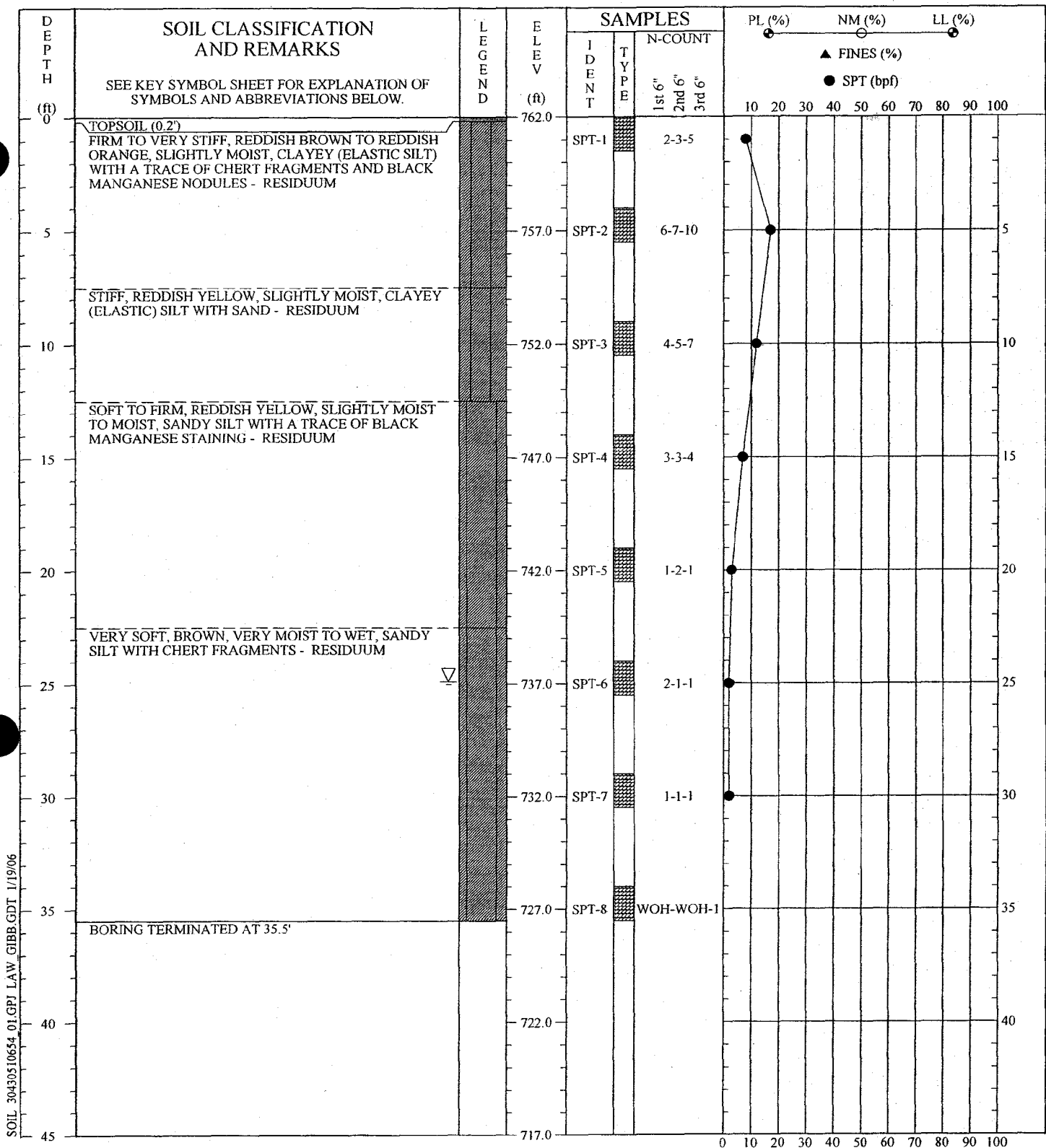

SOIL 30430510654 01.GPJ LAW GIBB.GDT 1/19/06

REMARKS: STANDARD PENETRATION RESISTANCE TESTING PERFORMED USING AN AUTOMATIC HAMMER.

THIS RECORD IS A REASONABLE INTERPRETATION OF SUBSURFACE CONDITIONS AT THE EXPLORATION LOCATION. SUBSURFACE CONDITIONS AT OTHER LOCATIONS AND AT OTHER TIMES MAY DIFFER. INTERFACES BETWEEN STRATA ARE APPROXIMATE. TRANSITIONS BETWEEN STRATA MAY BE GRADUAL.

Driller : Akins  
Prepared By: Justice  
Checked By: *AKJ*

SOIL TEST BORING RECORD	
<b>PROJECT:</b> TVA Kingston Additional Geotech	<b>BORING NO.:</b> MW-M
<b>DRILLED:</b> January 16, 2006	
<b>PROJ. NO.:</b> 3043051064/0001	<b>PAGE 1 OF 1</b>
	

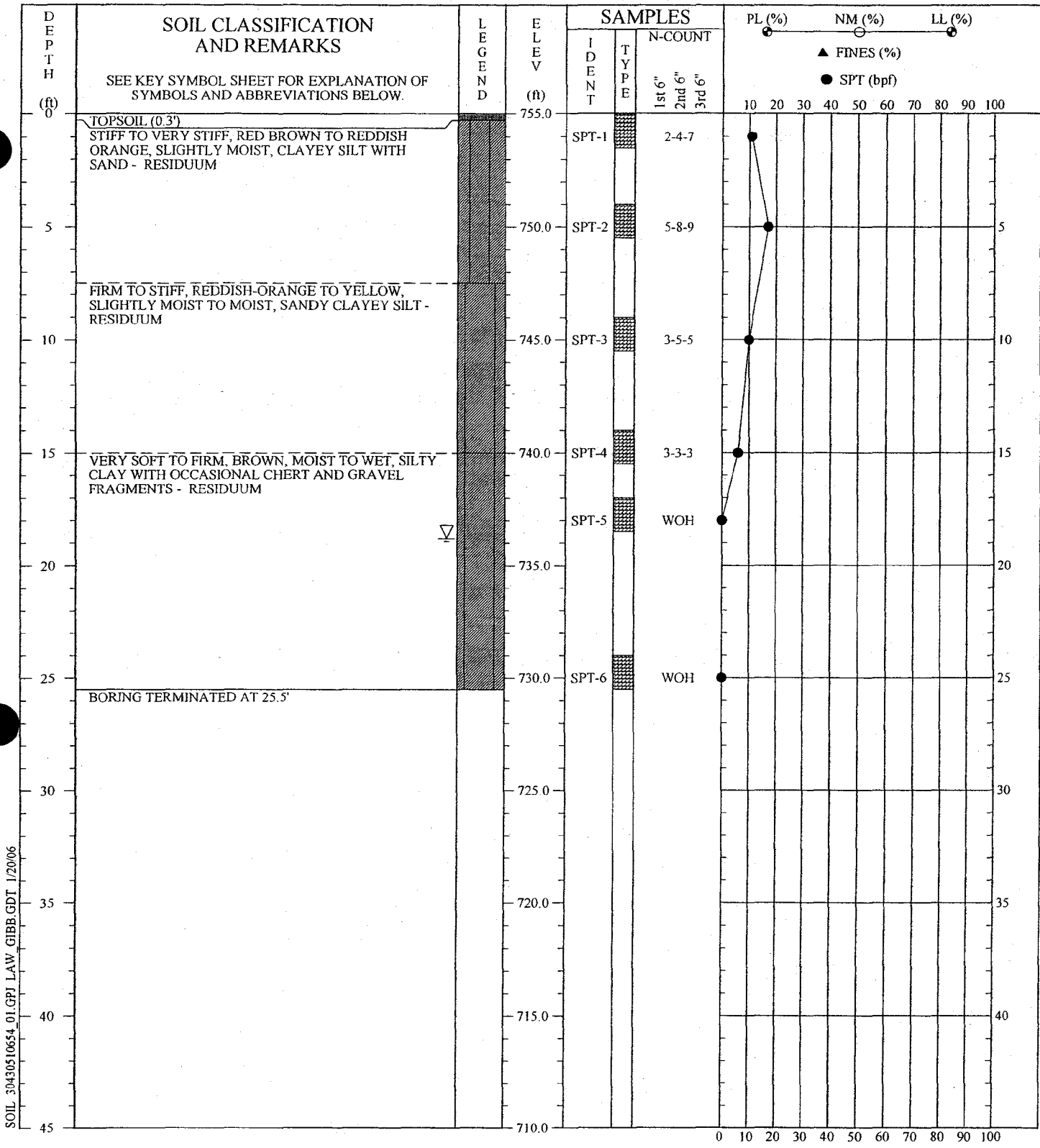

SOIL 30430510654\_01.GPJ LAW GIBB GDT 1/20/06

REMARKS: STANDARD PENETRATION RESISTANCE TESTING PERFORMED USING AN AUTOMATIC HAMMER.

SOIL TEST BORING RECORD	
<b>PROJECT:</b> TVA Kingston Additional Geotech	<b>BORING NO.:</b> MW-N
<b>DRILLED:</b> January 12, 2006	
<b>PROJ. NO.:</b> 3043051064/0001	<b>PAGE 1 OF 1</b>

THIS RECORD IS A REASONABLE INTERPRETATION OF SUBSURFACE CONDITIONS AT THE EXPLORATION LOCATION. SUBSURFACE CONDITIONS AT OTHER LOCATIONS AND AT OTHER TIMES MAY DIFFER. INTERFACES BETWEEN STRATA ARE APPROXIMATE. TRANSITIONS BETWEEN STRATA MAY BE GRADUAL.

Driller: Akins  
Prepared By: Justice  
Checked By: *AK*



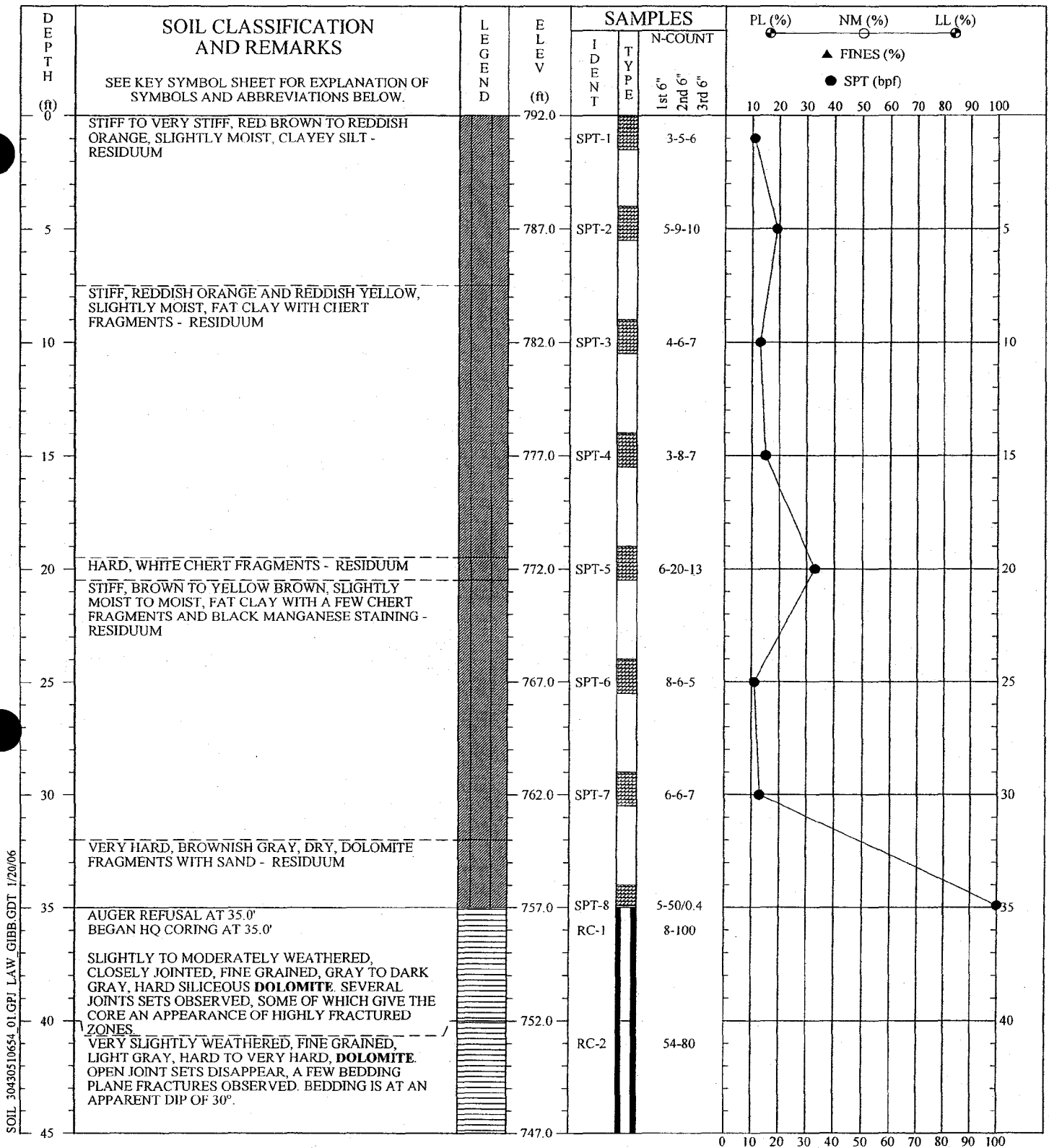

SOIL 30430510654 01.GPJ LAW\_GIBB.GDT 1/20/06

REMARKS: STANDARD PENETRATION RESISTANCE TESTING PERFORMED USING AN AUTOMATIC HAMMER. NO GROUND WATER ENCOUNTERED AT TIME OF EXPLORATION.

THIS RECORD IS A REASONABLE INTERPRETATION OF SUBSURFACE CONDITIONS AT THE EXPLORATION LOCATION. SUBSURFACE CONDITIONS AT OTHER LOCATIONS AND AT OTHER TIMES MAY DIFFER. INTERFACES BETWEEN STRATA ARE APPROXIMATE. TRANSITIONS BETWEEN STRATA MAY BE GRADUAL.

Driller : Akins  
Prepared By: Justice  
Checked By: *XOJ*

SOIL TEST BORING RECORD	
<b>PROJECT:</b> TVA Kingston Additional Geotech	<b>BORING NO.:</b> MW-P
<b>DRILLED:</b> July 12, 2006	
<b>PROJ. NO.:</b> 3043051064/0001	<b>PAGE 1 OF 2</b>



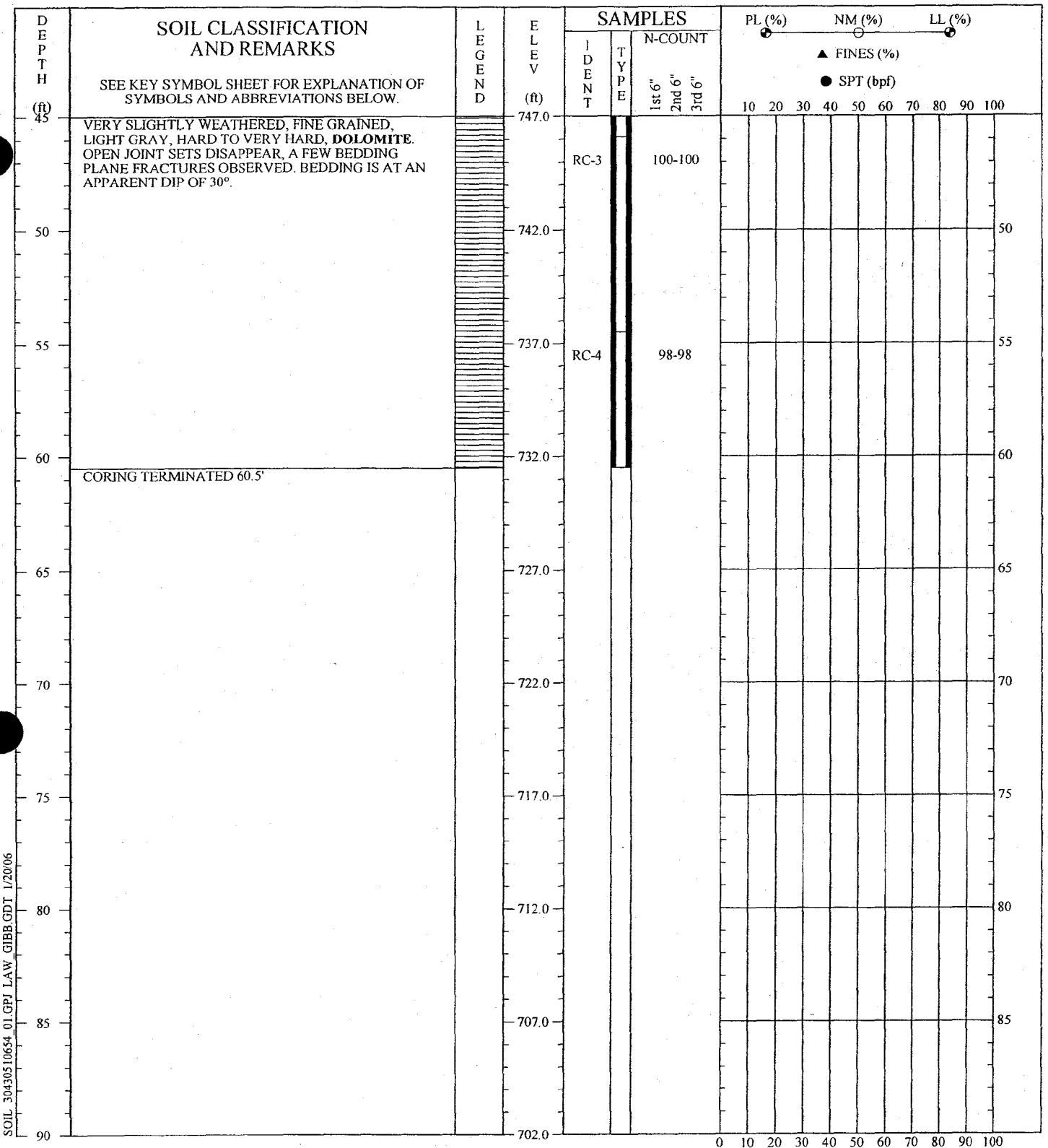

SOIL\_30430510654\_01.GPJ LAW\_GIBB.GDT 1/2006

REMARKS: STANDARD PENETRATION RESISTANCE TESTING PERFORMED USING AN AUTOMATIC HAMMER. NO GROUND WATER ENCOUNTERED AT TIME OF EXPLORATION.

THIS RECORD IS A REASONABLE INTERPRETATION OF SUBSURFACE CONDITIONS AT THE EXPLORATION LOCATION. SUBSURFACE CONDITIONS AT OTHER LOCATIONS AND AT OTHER TIMES MAY DIFFER. INTERFACES BETWEEN STRATA ARE APPROXIMATE. TRANSITIONS BETWEEN STRATA MAY BE GRADUAL.

Driller : Akins  
Prepared By: Justice  
Checked By: *[Signature]*

SOIL TEST BORING RECORD	
PROJECT: TVA Kingston Additional Geotech	
DRILLED: July 12, 2006	BORING NO.: MW-P
PROJ. NO.: 3043051064/0001	PAGE 2 OF 2

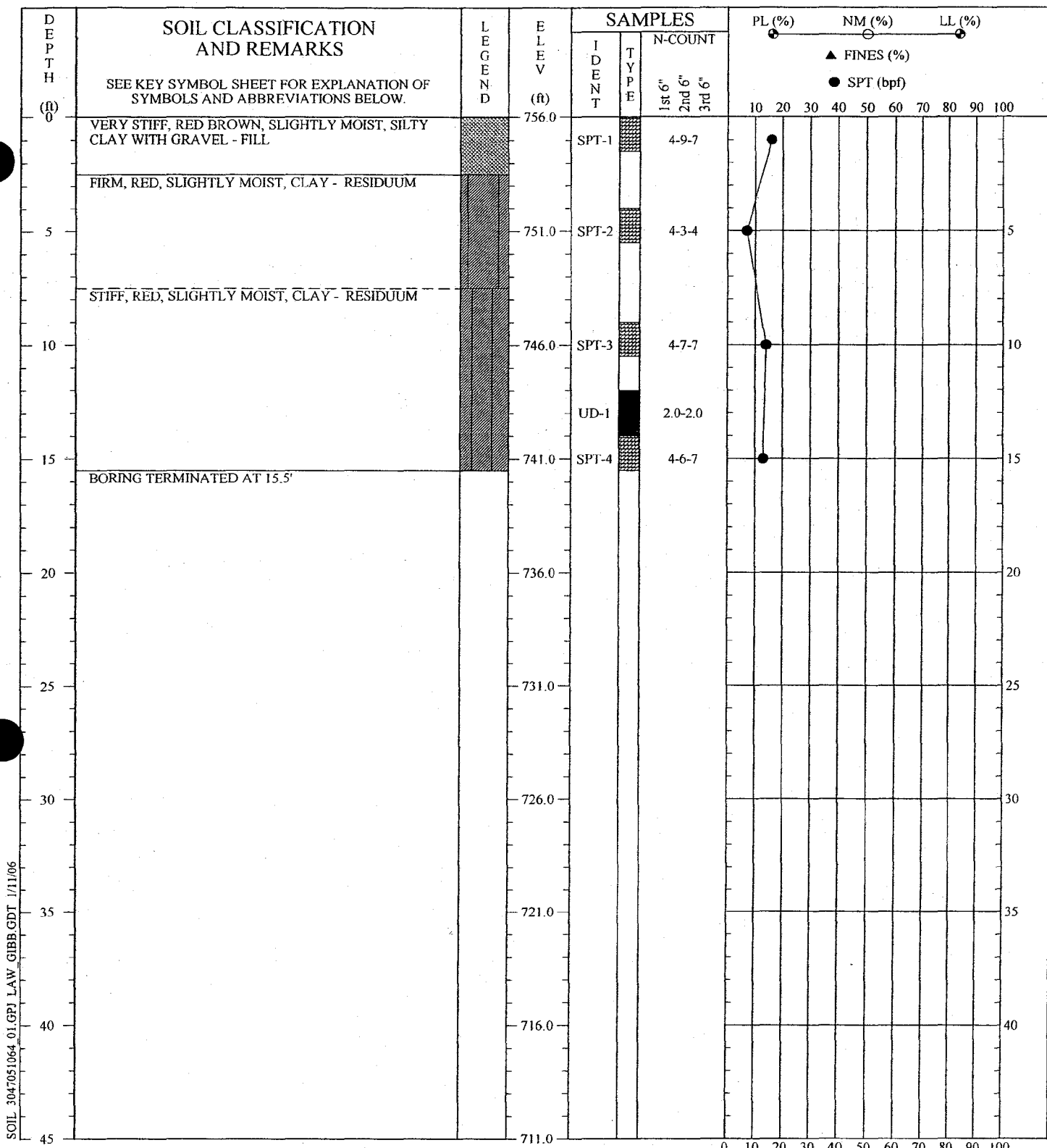

SOIL 3047051064\_01.GPJ LAW GIBB GDT 1/11/06

REMARKS: STANDARD PENETRATION RESISTANCE TESTING PERFORMED USING AN AUTOMATIC HAMMER. NO GROUND WATER ENCOUNTERED AT TIME OF EXPLORATION.

**SOIL TEST BORING RECORD**

**PROJECT:** TVA Kingston  
**DRILLED:** November 18, 2005      **BORING NO.:** K-1  
**PROJ. NO.:** 3043051064/0001      **PAGE 1 OF 1**

THIS RECORD IS A REASONABLE INTERPRETATION OF SUBSURFACE CONDITIONS AT THE EXPLORATION LOCATION. SUBSURFACE CONDITIONS AT OTHER LOCATIONS AND AT OTHER TIMES MAY DIFFER. INTERFACES BETWEEN STRATA ARE APPROXIMATE. TRANSITIONS BETWEEN STRATA MAY BE GRADUAL.

Driller : Marshall  
 Prepared By: M.O.  
 Checked By: *[Signature]*



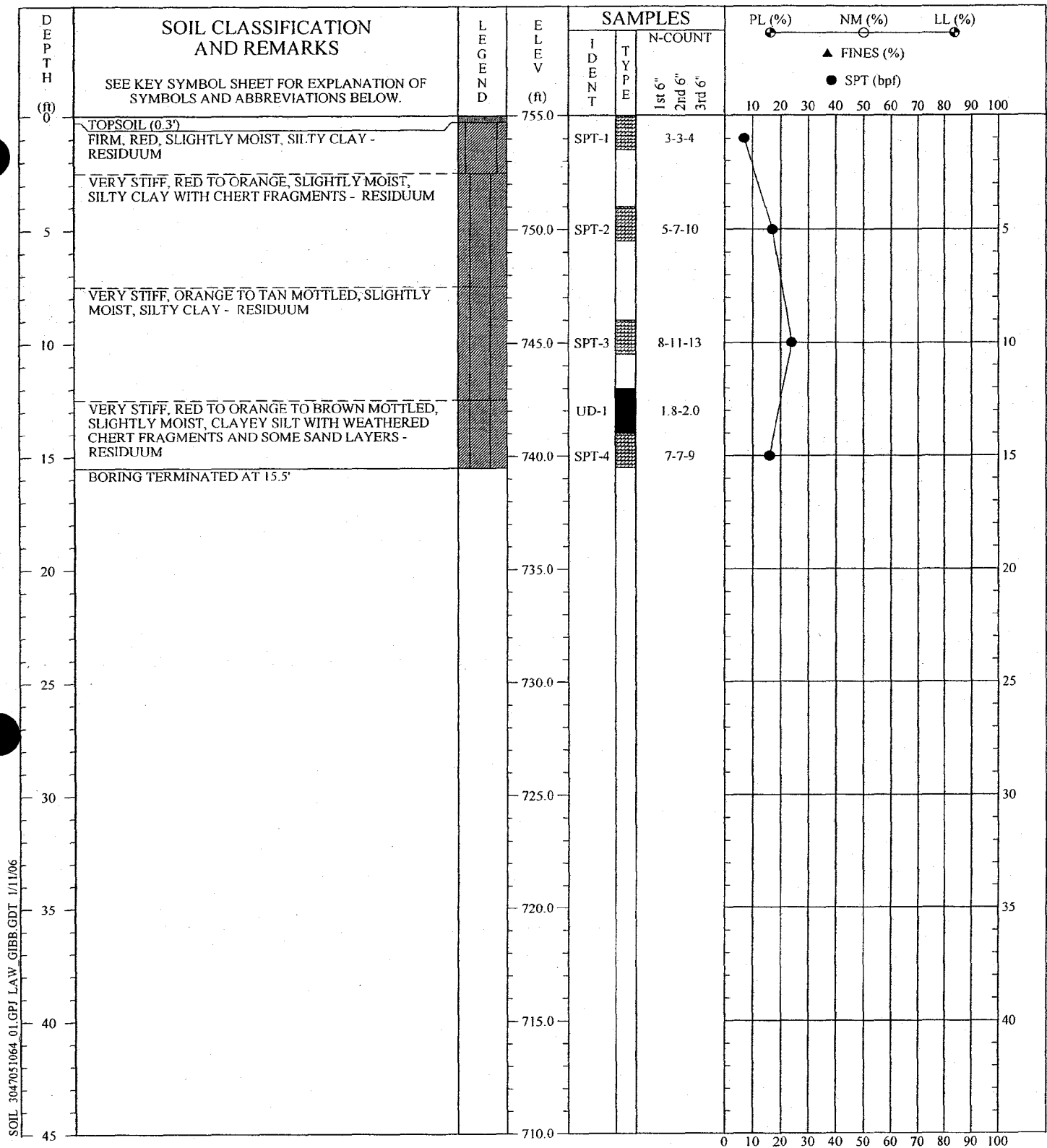

SOIL 3047051064 01.GPJ LAW GIBB.GDT 1/11/06

REMARKS: STANDARD PENETRATION RESISTANCE TESTING PERFORMED USING AN AUTOMATIC HAMMER. NO GROUND WATER ENCOUNTERED AT TIME OF EXPLORATION.

**SOIL TEST BORING RECORD**

**PROJECT:** TVA Kingston  
**DRILLED:** November 23, 2005      **BORING NO.:** K-2  
**PROJ. NO.:** 3043051064/0001      **PAGE 1 OF 1**

THIS RECORD IS A REASONABLE INTERPRETATION OF SUBSURFACE CONDITIONS AT THE EXPLORATION LOCATION. SUBSURFACE CONDITIONS AT OTHER LOCATIONS AND AT OTHER TIMES MAY DIFFER. INTERFACES BETWEEN STRATA ARE APPROXIMATE. TRANSITIONS BETWEEN STRATA MAY BE GRADUAL.

Driller: Marshall  
 Prepared By: M.O.  
 Checked By: *MA*



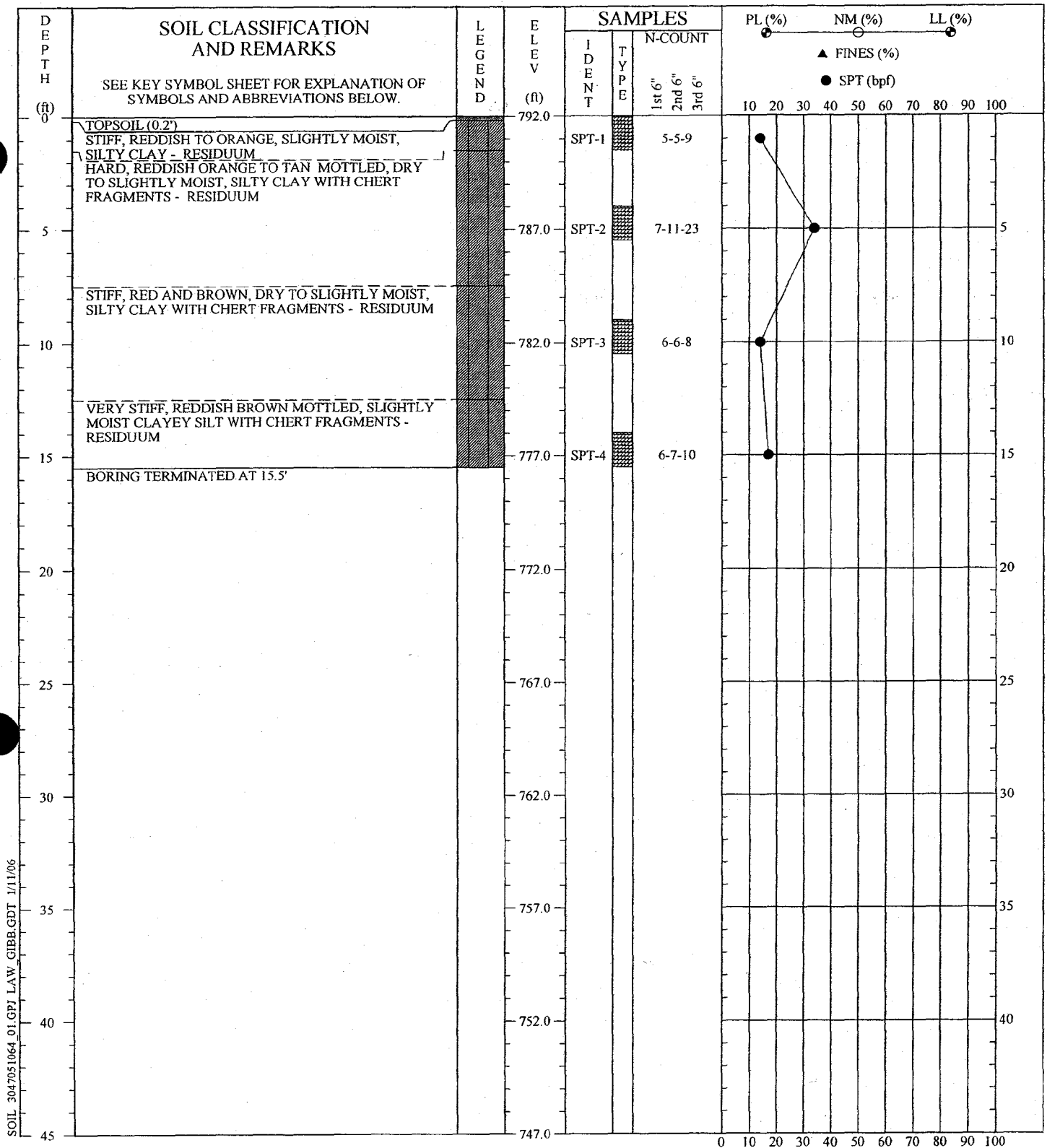

SOIL 3047051064 01.GPJ LAW\_GIBB.GDT 1/11/06

REMARKS: STANDARD PENETRATION RESISTANCE TESTING PERFORMED USING AN AUTOMATIC HAMMER. NO GROUND WATER ENCOUNTERED AT TIME OF EXPLORATION.

THIS RECORD IS A REASONABLE INTERPRETATION OF SUBSURFACE CONDITIONS AT THE EXPLORATION LOCATION. SUBSURFACE CONDITIONS AT OTHER LOCATIONS AND AT OTHER TIMES MAY DIFFER. INTERFACES BETWEEN STRATA ARE APPROXIMATE. TRANSITIONS BETWEEN STRATA MAY BE GRADUAL.

Driller : Marshall  
Prepared By: M.O.  
Checked By: *[Signature]*

SOIL TEST BORING RECORD	
<b>PROJECT:</b> TVA Kingston	<b>BORING NO.:</b> K-3
<b>DRILLED:</b> November 15, 2005	
<b>PROJ. NO.:</b> 3043051064/0001	<b>PAGE 1 OF 1</b>
	

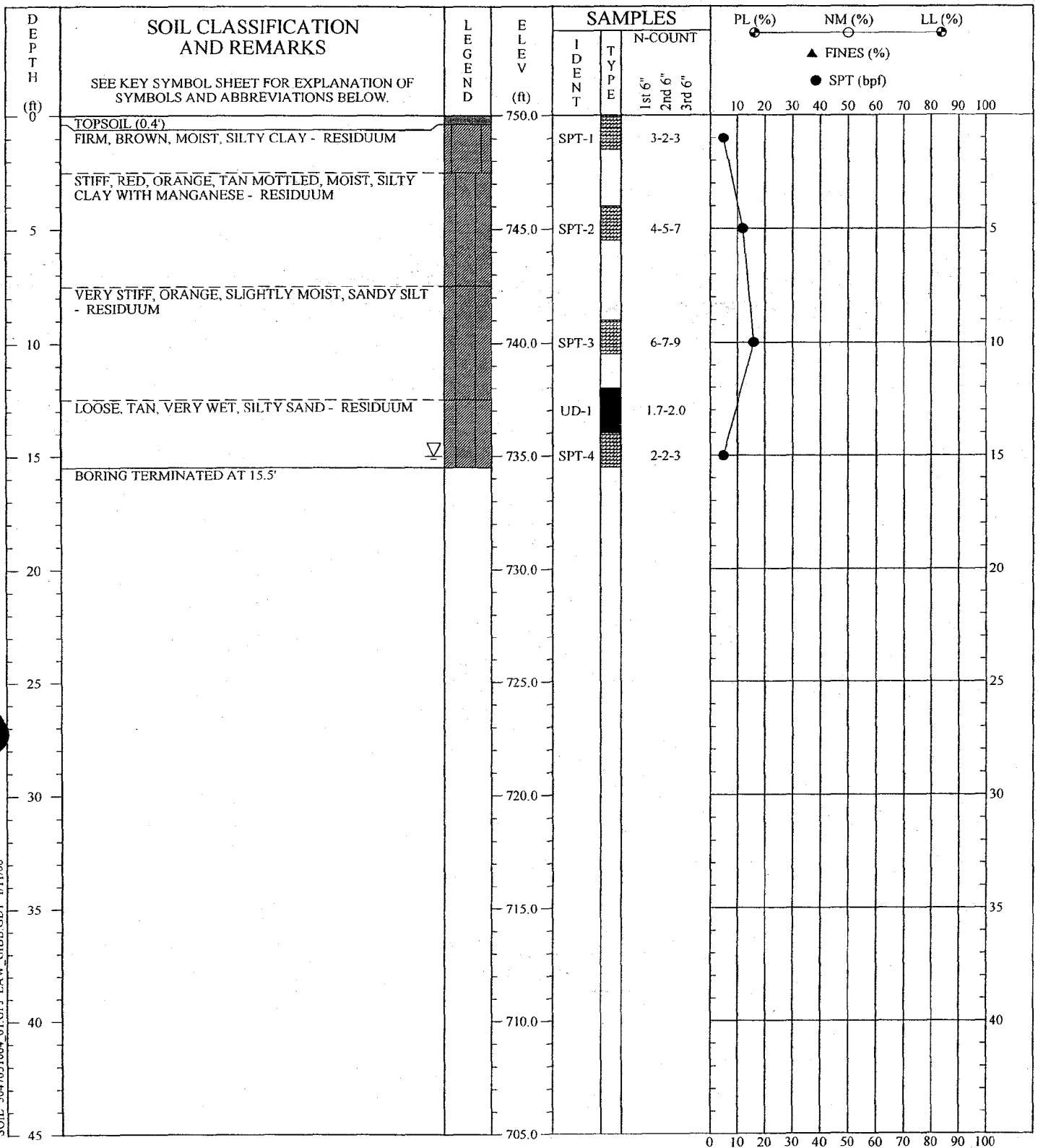

SOIL\_3047051064\_01.GPJ LAW\_GIBB.GDT 1/11/06

REMARKS: STANDARD PENETRATION RESISTANCE TESTING PERFORMED USING AN AUTOMATIC HAMMER.

THIS RECORD IS A REASONABLE INTERPRETATION OF SUBSURFACE CONDITIONS AT THE EXPLORATION LOCATION. SUBSURFACE CONDITIONS AT OTHER LOCATIONS AND AT OTHER TIMES MAY DIFFER. INTERFACES BETWEEN STRATA ARE APPROXIMATE. TRANSITIONS BETWEEN STRATA MAY BE GRADUAL.

Driller : Marshall  
Prepared By: M.O.  
Checked By: *[Signature]*

SOIL TEST BORING RECORD	
<b>PROJECT:</b> TVA Kingston	
<b>DRILLED:</b> November 22, 2005	<b>BORING NO.:</b> K-4
<b>PROJ. NO.:</b> 3043051064/0001	<b>PAGE 1 OF 1</b>
	

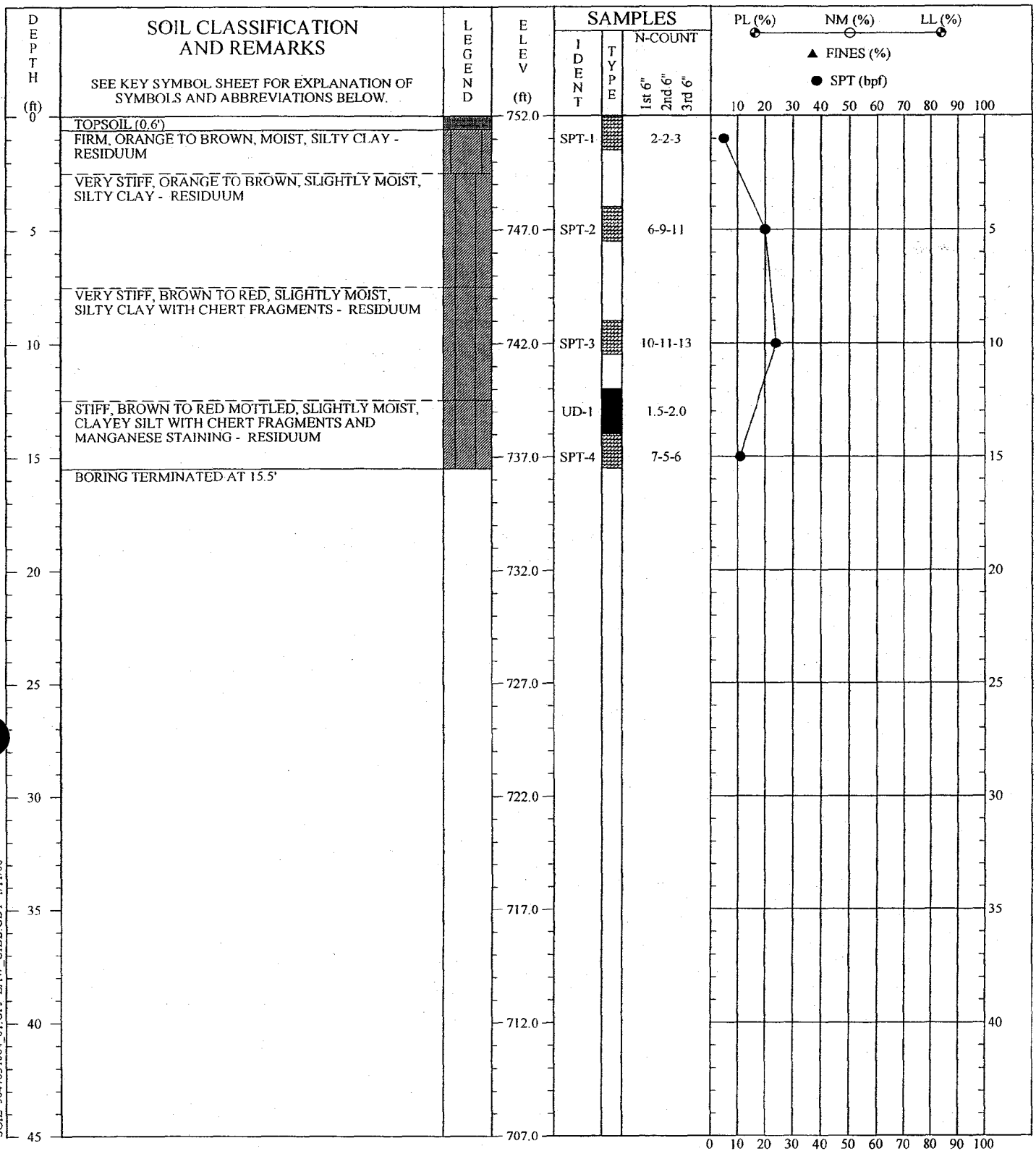

SOIL\_3047051064\_01.GPJ LAW\_GIBB\_GDT\_1/11/06

REMARKS: STANDARD PENETRATION RESISTANCE TESTING PERFORMED USING AN AUTOMATIC HAMMER. NO GROUND WATER ENCOUNTERED AT TIME OF EXPLORATION.

THIS RECORD IS A REASONABLE INTERPRETATION OF SUBSURFACE CONDITIONS AT THE EXPLORATION LOCATION. SUBSURFACE CONDITIONS AT OTHER LOCATIONS AND AT OTHER TIMES MAY DIFFER. INTERFACES BETWEEN STRATA ARE APPROXIMATE. TRANSITIONS BETWEEN STRATA MAY BE GRADUAL.

Driller: Marshall  
Prepared By: M.O.  
Checked By: *[Signature]*

SOIL TEST BORING RECORD	
PROJECT: TVA Kingston	
DRILLED: November 23, 2005	BORING NO.: K-5
PROJ. NO.: 3043051064/0001	PAGE 1 OF 1

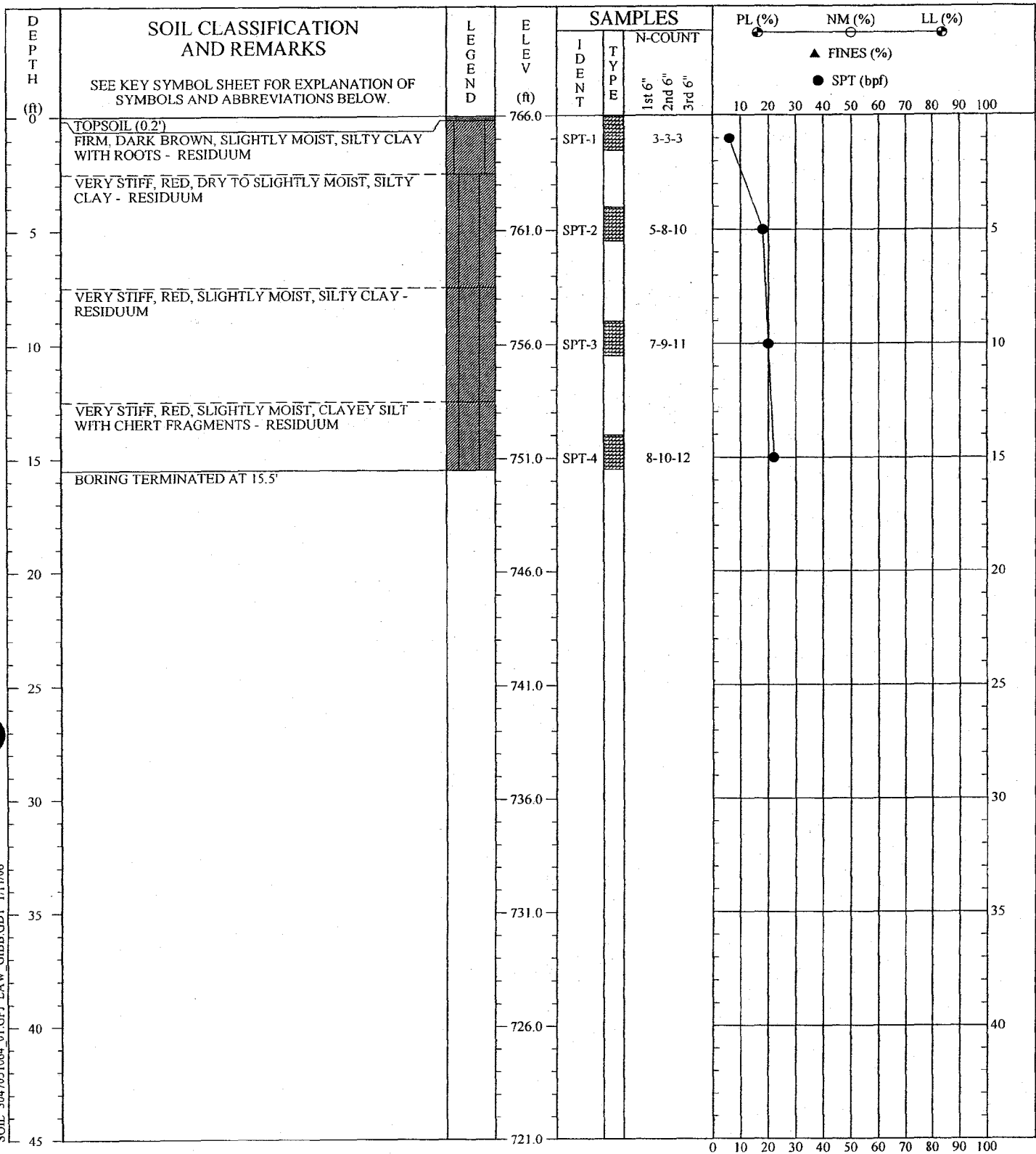

SOIL\_3047051064\_01.GPJ LAW\_GIBB.GDT 1/11/06

REMARKS: STANDARD PENETRATION RESISTANCE TESTING PERFORMED USING AN AUTOMATIC HAMMER. NO GROUND WATER ENCOUNTERED AT TIME OF EXPLORATION.

**SOIL TEST BORING RECORD**

**PROJECT:** TVA Kingston  
**DRILLED:** November 15, 2005      **BORING NO.:** K-6  
**PROJ. NO.:** 3043051064/0001      **PAGE 1 OF 1**

THIS RECORD IS A REASONABLE INTERPRETATION OF SUBSURFACE CONDITIONS AT THE EXPLORATION LOCATION. SUBSURFACE CONDITIONS AT OTHER LOCATIONS AND AT OTHER TIMES MAY DIFFER. INTERFACES BETWEEN STRATA ARE APPROXIMATE. TRANSITIONS BETWEEN STRATA MAY BE GRADUAL.

Driller : Marshall  
 Prepared By: M.O.  
 Checked By: *[Signature]*



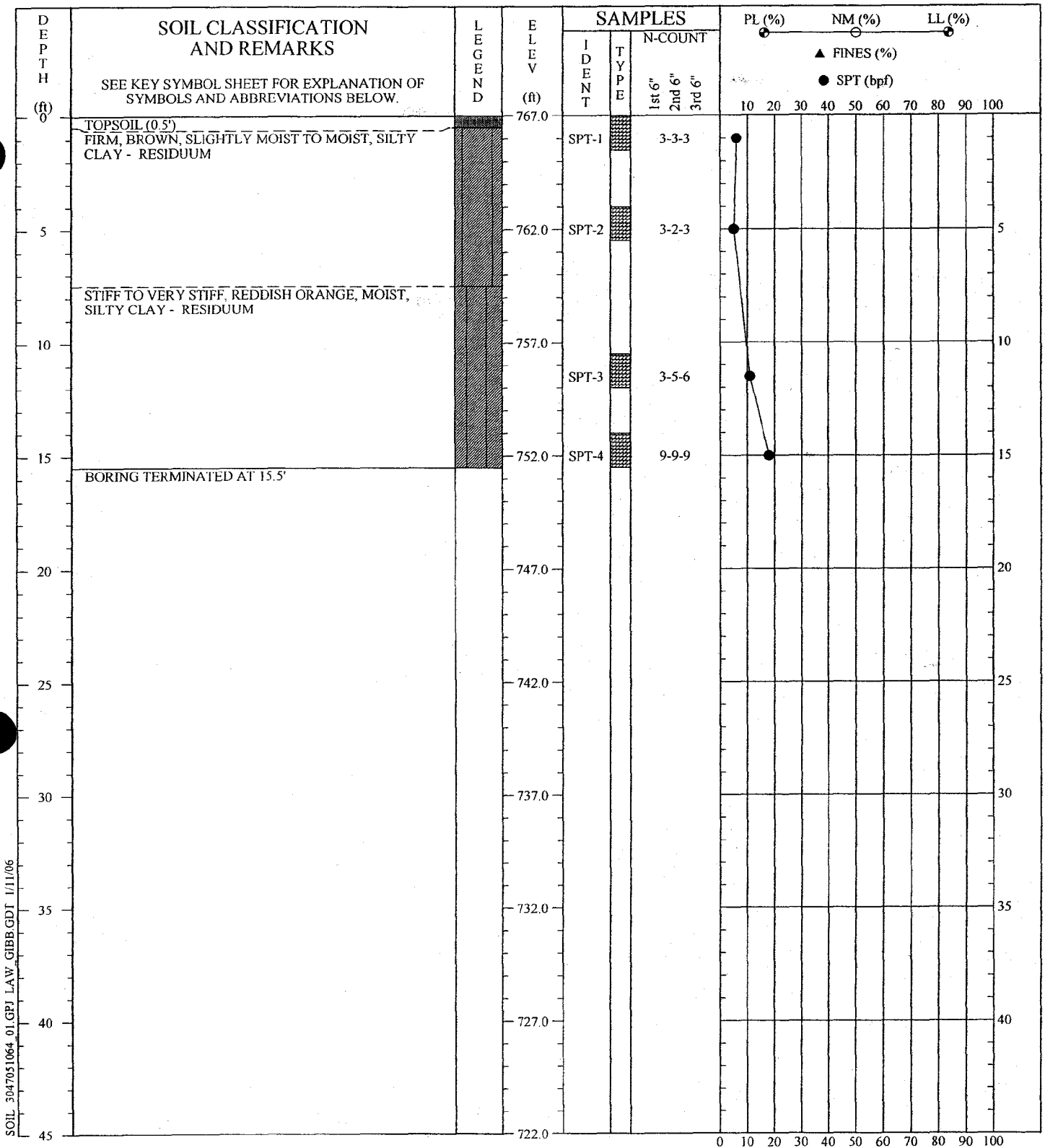

SOIL 3047051064 01.GPJ LAW\_GIBBGDI 1/11/06

REMARKS: STANDARD PENETRATION RESISTANCE TESTING PERFORMED USING AN AUTOMATIC HAMMER. NO GROUND WATER ENCOUNTERED AT TIME OF EXPLORATION.

**SOIL TEST BORING RECORD**

**PROJECT:** TVA Kingston  
**DRILLED:** November 22, 2005      **BORING NO.:** K-7  
**PROJ. NO.:** 3043051064/0001      **PAGE 1 OF 1**

THIS RECORD IS A REASONABLE INTERPRETATION OF SUBSURFACE CONDITIONS AT THE EXPLORATION LOCATION. SUBSURFACE CONDITIONS AT OTHER LOCATIONS AND AT OTHER TIMES MAY DIFFER. INTERFACES BETWEEN STRATA ARE APPROXIMATE. TRANSITIONS BETWEEN STRATA MAY BE GRADUAL.

Driller: Marshall  
 Prepared By: M.O.  
 Checked By: *[Signature]*





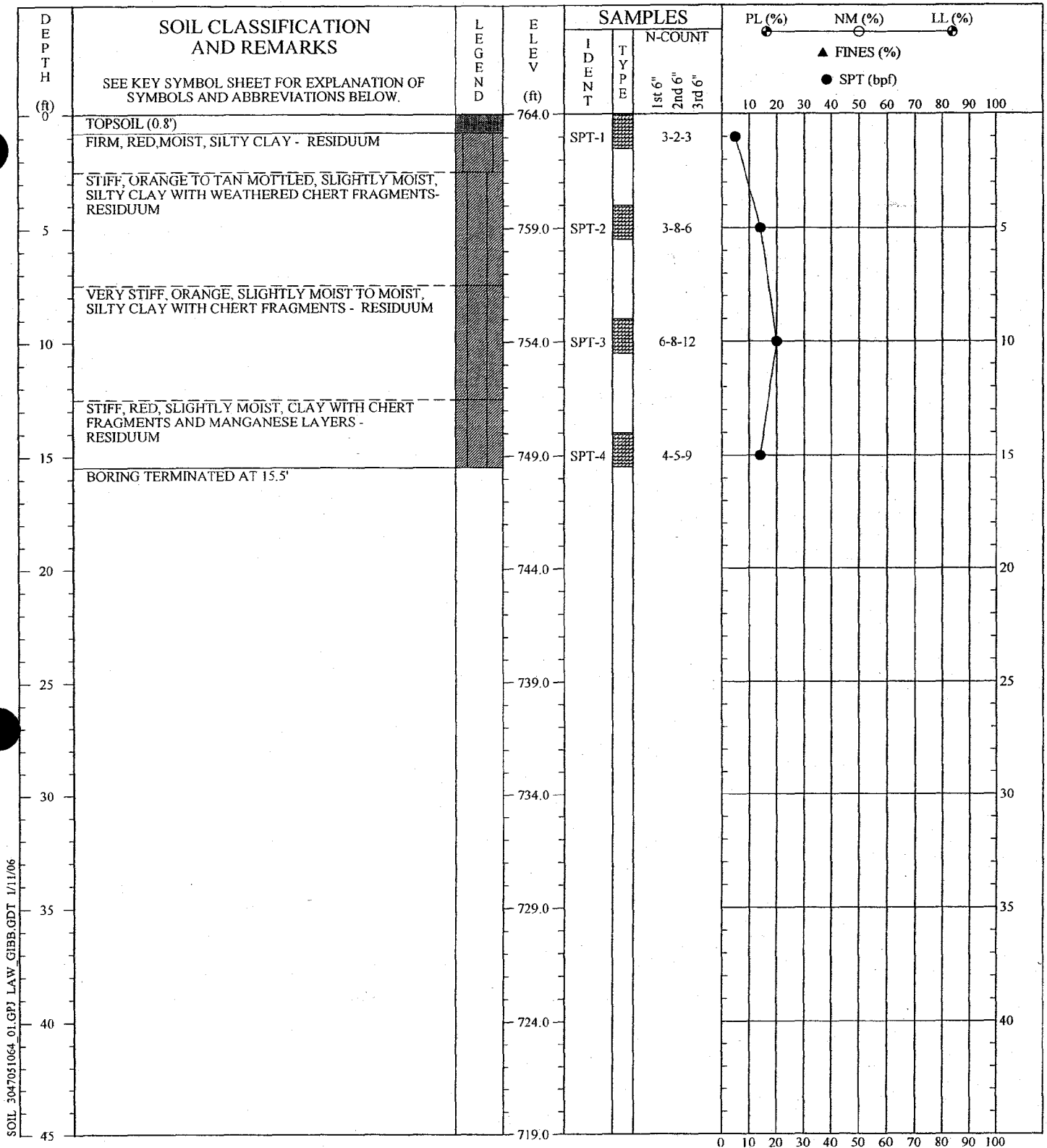

SOIL 3047051064\_01.GPJ LAW GIBB.GDT 1/11/06

REMARKS: STANDARD PENETRATION RESISTANCE TESTING PERFORMED USING AN AUTOMATIC HAMMER. NO GROUND WATER ENCOUNTERED AT TIME OF EXPLORATION.

THIS RECORD IS A REASONABLE INTERPRETATION OF SUBSURFACE CONDITIONS AT THE EXPLORATION LOCATION. SUBSURFACE CONDITIONS AT OTHER LOCATIONS AND AT OTHER TIMES MAY DIFFER. INTERFACES BETWEEN STRATA ARE APPROXIMATE. TRANSITIONS BETWEEN STRATA MAY BE GRADUAL.

Driller : Marshall  
Prepared By: M.O.  
Checked By: *[Signature]*

SOIL TEST BORING RECORD	
<b>PROJECT:</b> TVA Kingston	<b>BORING NO.:</b> K-8
<b>DRILLED:</b> November 22, 2005	<b>PAGE 1 OF 1</b>
<b>PROJ. NO.:</b> 3043051064/0001	
	

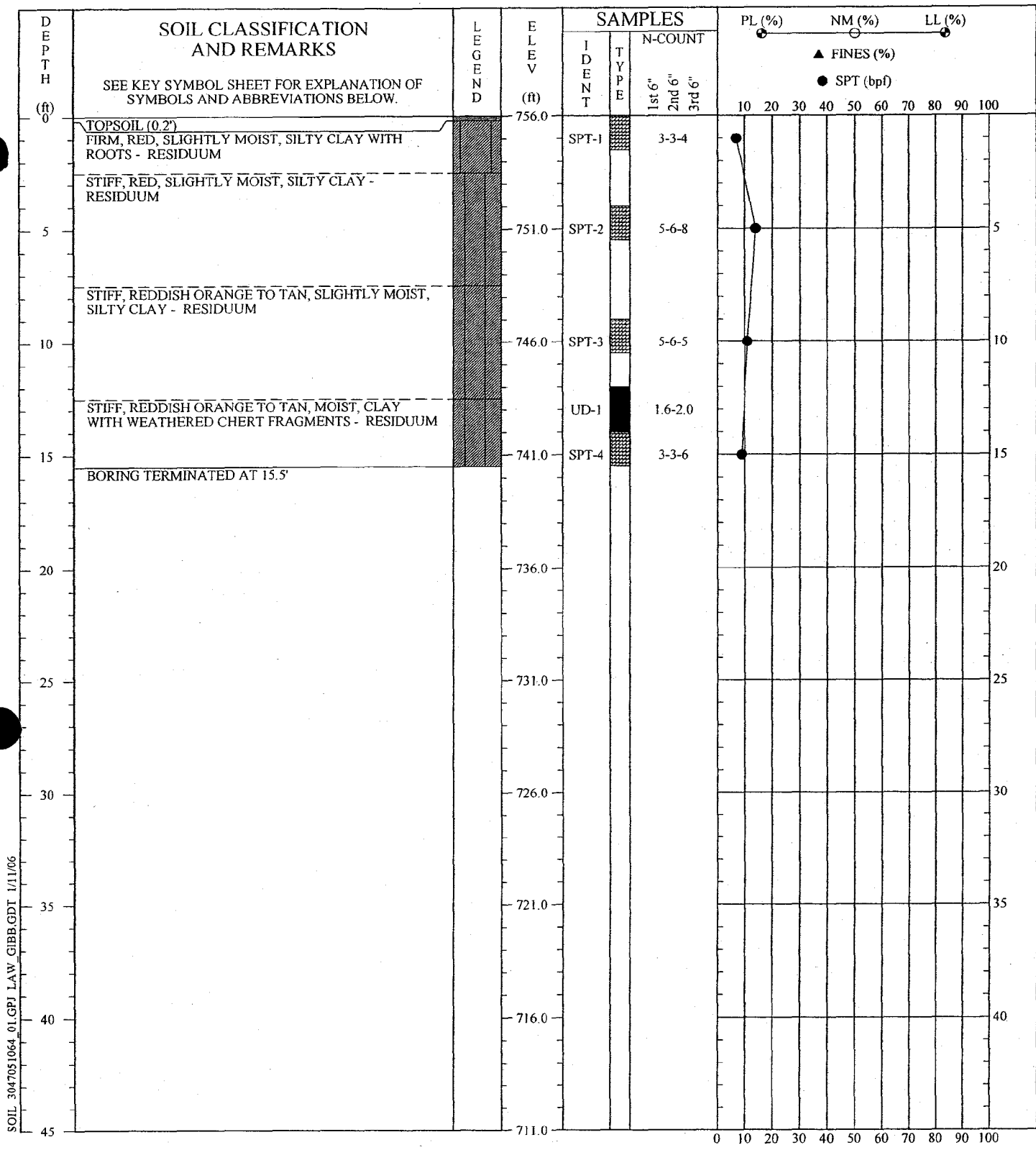

SOIL 3043051064\_01.GPJ LAW\_GIBB.GDT 1/11/06

REMARKS: STANDARD PENETRATION RESISTANCE TESTING PERFORMED USING AN AUTOMATIC HAMMER. NO GROUND WATER ENCOUNTERED AT TIME OF EXPLORATION.

SOIL TEST BORING RECORD	
<b>PROJECT:</b> TVA Kingston	<b>BORING NO.:</b> K-9
<b>DRILLED:</b> November 18, 2005	
<b>PROJ. NO.:</b> 3043051064/0001	<b>PAGE 1 OF 1</b>

THIS RECORD IS A REASONABLE INTERPRETATION OF SUBSURFACE CONDITIONS AT THE EXPLORATION LOCATION. SUBSURFACE CONDITIONS AT OTHER LOCATIONS AND AT OTHER TIMES MAY DIFFER. INTERFACES BETWEEN STRATA ARE APPROXIMATE. TRANSITIONS BETWEEN STRATA MAY BE GRADUAL.

Driller : Warren  
Prepared By: M.O.  
Checked By: *[Signature]*



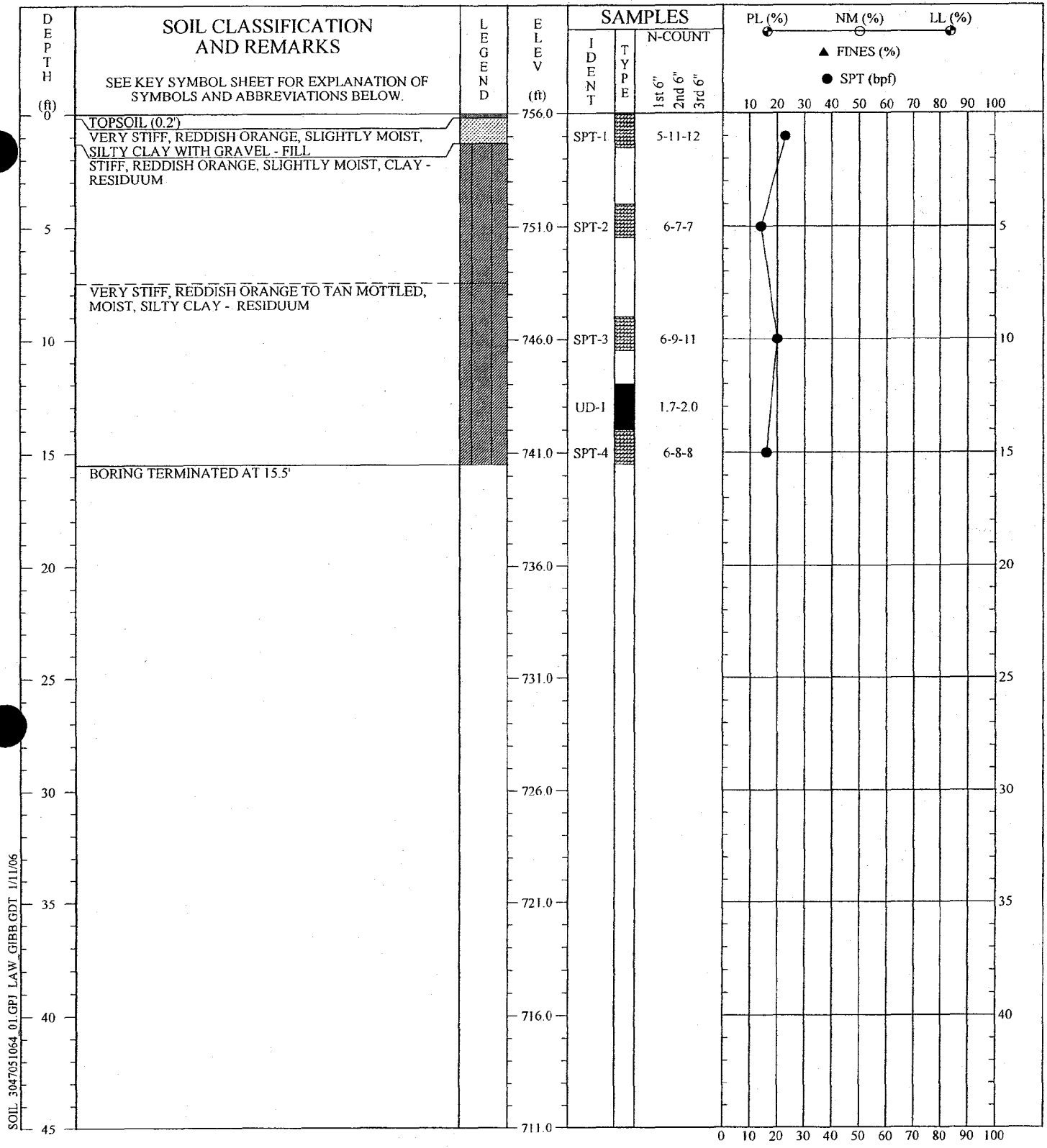

SOIL 3047051064 01.GPI LAW\_GIBB.GDT 1/11/06

REMARKS: STANDARD PENETRATION RESISTANCE TESTING PERFORMED USING AN AUTOMATIC HAMMER. NO GROUND WATER ENCOUNTERED AT TIME OF EXPLORATION.

SOIL TEST BORING RECORD	
<b>PROJECT:</b> TVA Kingston	<b>BORING NO.:</b> K-10
<b>DRILLED:</b> November 22, 2005	<b>PAGE 1 OF 1</b>
<b>PROJ. NO.:</b> 3043051064/0001	
	

THIS RECORD IS A REASONABLE INTERPRETATION OF SUBSURFACE CONDITIONS AT THE EXPLORATION LOCATION. SUBSURFACE CONDITIONS AT OTHER LOCATIONS AND AT OTHER TIMES MAY DIFFER. INTERFACES BETWEEN STRATA ARE APPROXIMATE. TRANSITIONS BETWEEN STRATA MAY BE GRADUAL.

Driller : Marshall  
 Prepared By: M.O.  
 Checked By: *[Signature]*

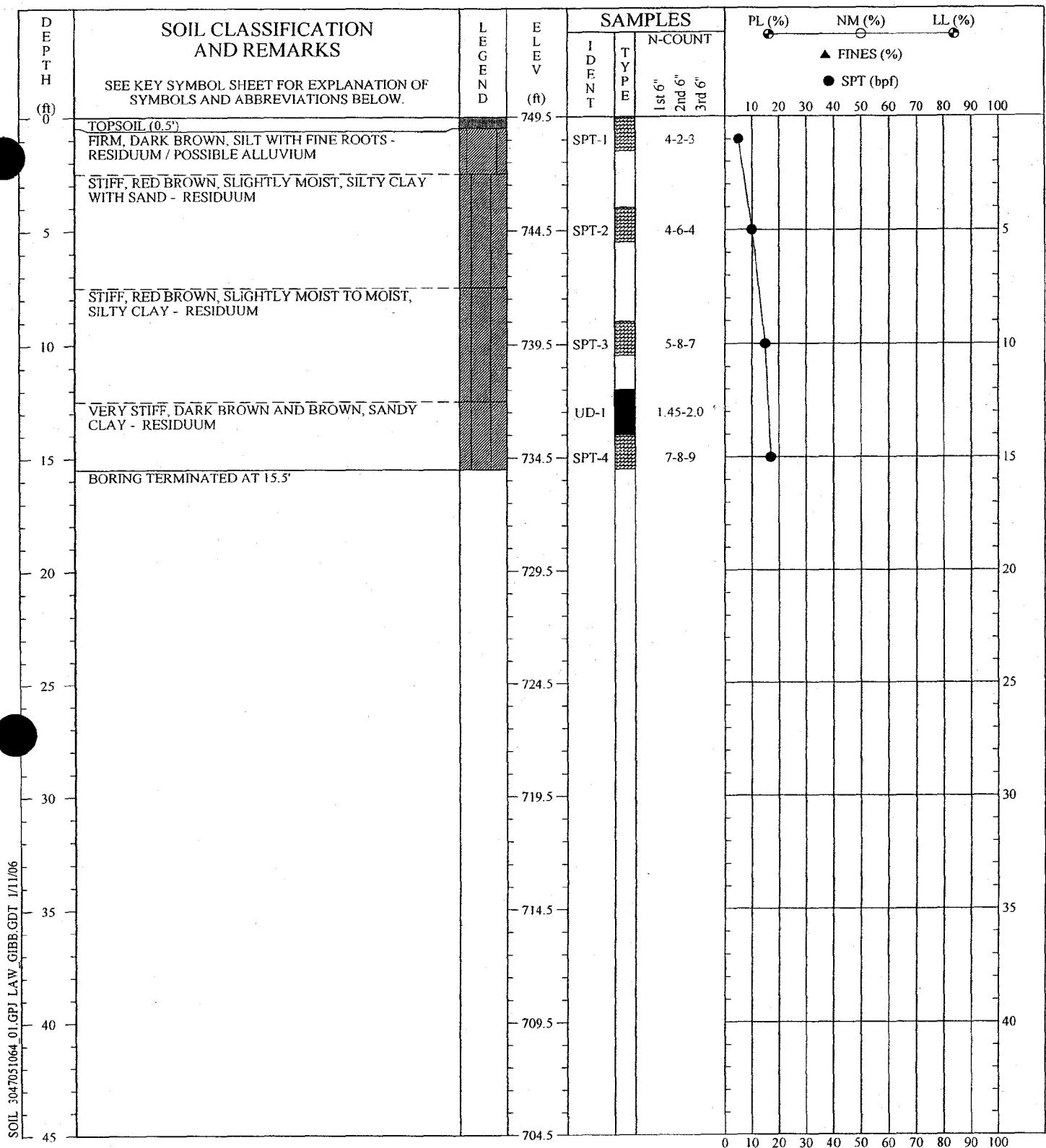

SOIL 3047051064 01.GPJ LAW, GIBB.GDT 1/11/06

REMARKS: STANDARD PENETRATION RESISTANCE TESTING PERFORMED USING AN AUTOMATIC HAMMER. NO GROUND WATER ENCOUNTERED AT TIME OF EXPLORATION.

**SOIL TEST BORING RECORD**

**PROJECT:** TVA Kingston  
**DRILLED:** November 30, 2005      **BORING NO.:** K-11  
**PROJ. NO.:** 3043051064/0001      **PAGE 1 OF 1**

THIS RECORD IS A REASONABLE INTERPRETATION OF SUBSURFACE CONDITIONS AT THE EXPLORATION LOCATION. SUBSURFACE CONDITIONS AT OTHER LOCATIONS AND AT OTHER TIMES MAY DIFFER. INTERFACES BETWEEN STRATA ARE APPROXIMATE. TRANSITIONS BETWEEN STRATA MAY BE GRADUAL.

Driller: Warren  
 Prepared By: Justice  
 Checked By: *[Signature]*



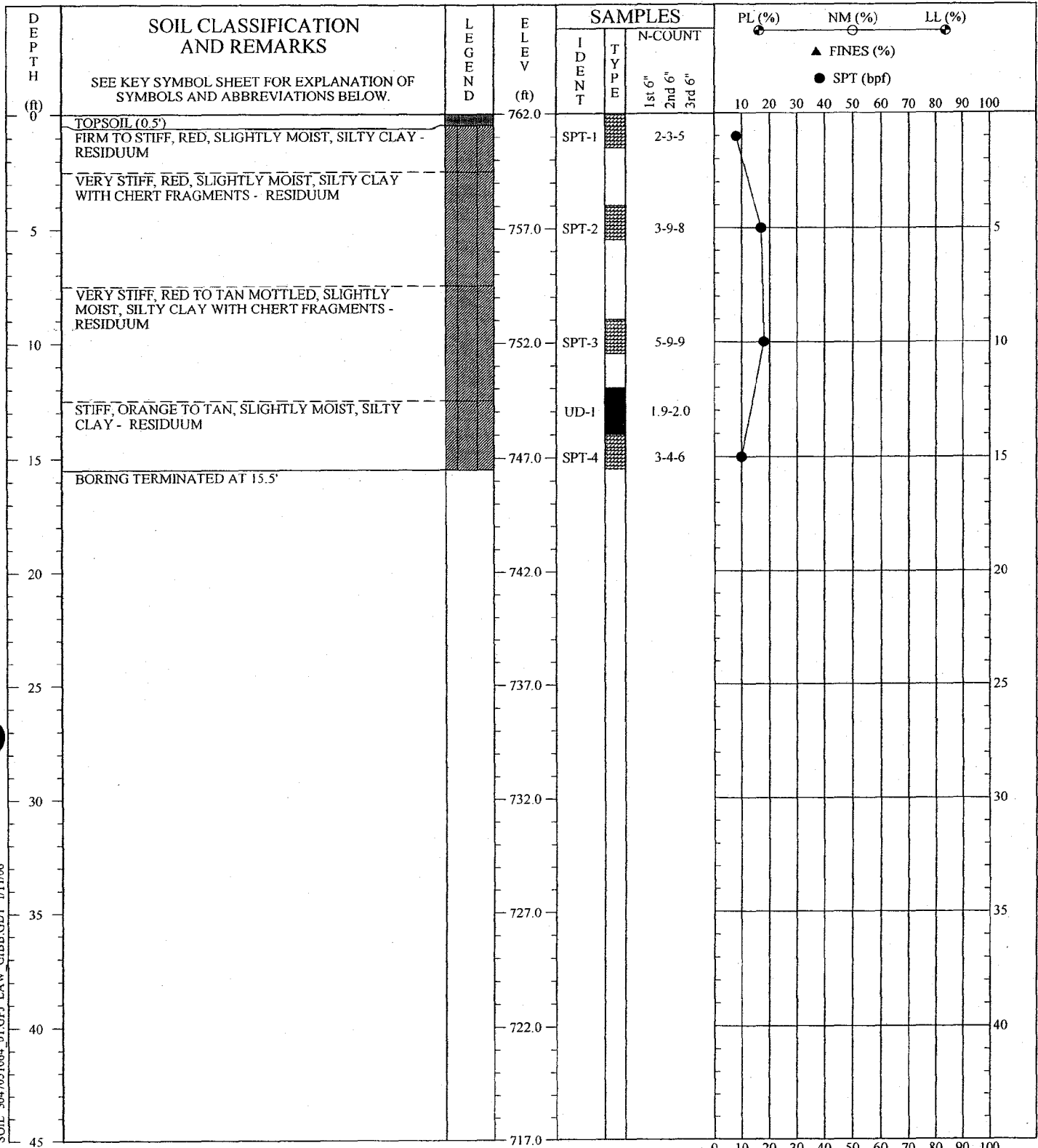

SOIL 3047051064 01.GPJ LAW GIBB.GDT 1/11/06

REMARKS: STANDARD PENETRATION RESISTANCE TESTING PERFORMED USING AN AUTOMATIC HAMMER. NO GROUND WATER ENCOUNTERED AT TIME OF EXPLORATION.

**SOIL TEST BORING RECORD**

**PROJECT:** TVA Kingston  
**DRILLED:** November 18, 2005      **BORING NO.:** K-12  
**PROJ. NO.:** 3043051064/0001      **PAGE 1 OF 1**

THIS RECORD IS A REASONABLE INTERPRETATION OF SUBSURFACE CONDITIONS AT THE EXPLORATION LOCATION. SUBSURFACE CONDITIONS AT OTHER LOCATIONS AND AT OTHER TIMES MAY DIFFER. INTERFACES BETWEEN STRATA ARE APPROXIMATE. TRANSITIONS BETWEEN STRATA MAY BE GRADUAL.

Driller: Warren  
 Prepared By: M.O.  
 Checked By: *[Signature]*



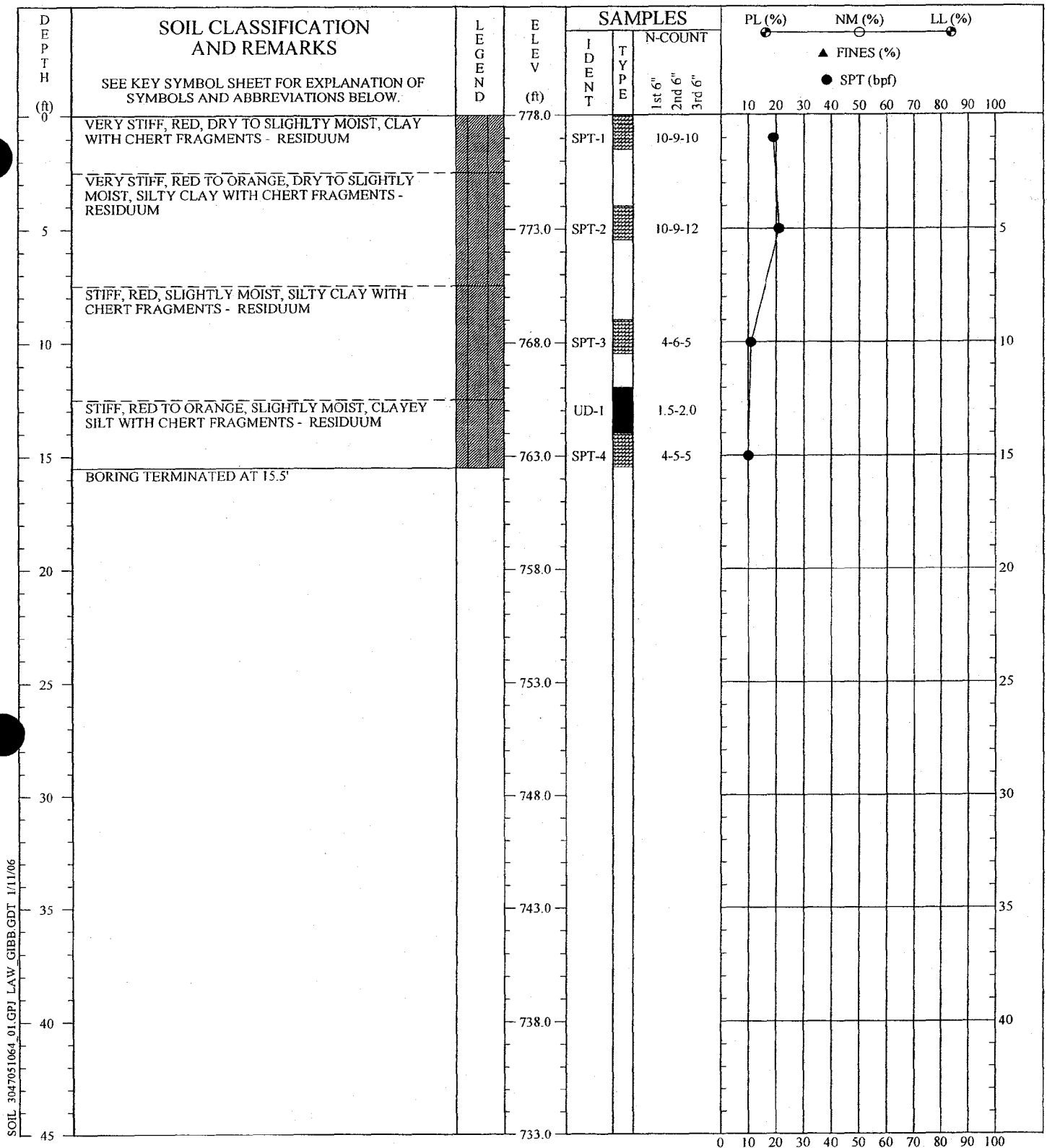

SOIL 3047051064 01.GPJ LAW GIBB.GDT 1/11/06

REMARKS: STANDARD PENETRATION RESISTANCE TESTING PERFORMED USING AN AUTOMATIC HAMMER. NO GROUND WATER ENCOUNTERED AT TIME OF EXPLORATION.

THIS RECORD IS A REASONABLE INTERPRETATION OF SUBSURFACE CONDITIONS AT THE EXPLORATION LOCATION. SUBSURFACE CONDITIONS AT OTHER LOCATIONS AND AT OTHER TIMES MAY DIFFER. INTERFACES BETWEEN STRATA ARE APPROXIMATE. TRANSITIONS BETWEEN STRATA MAY BE GRADUAL.

Driller : Warren  
Prepared By: M.O.  
Checked By: *[Signature]*

SOIL TEST BORING RECORD	
<b>PROJECT:</b> TVA Kingston	<b>BORING NO.:</b> K-13
<b>DRILLED:</b> November 18, 2005	<b>PROJ. NO.:</b> 3043051064/0001
<b>PAGE 1 OF 1</b>	

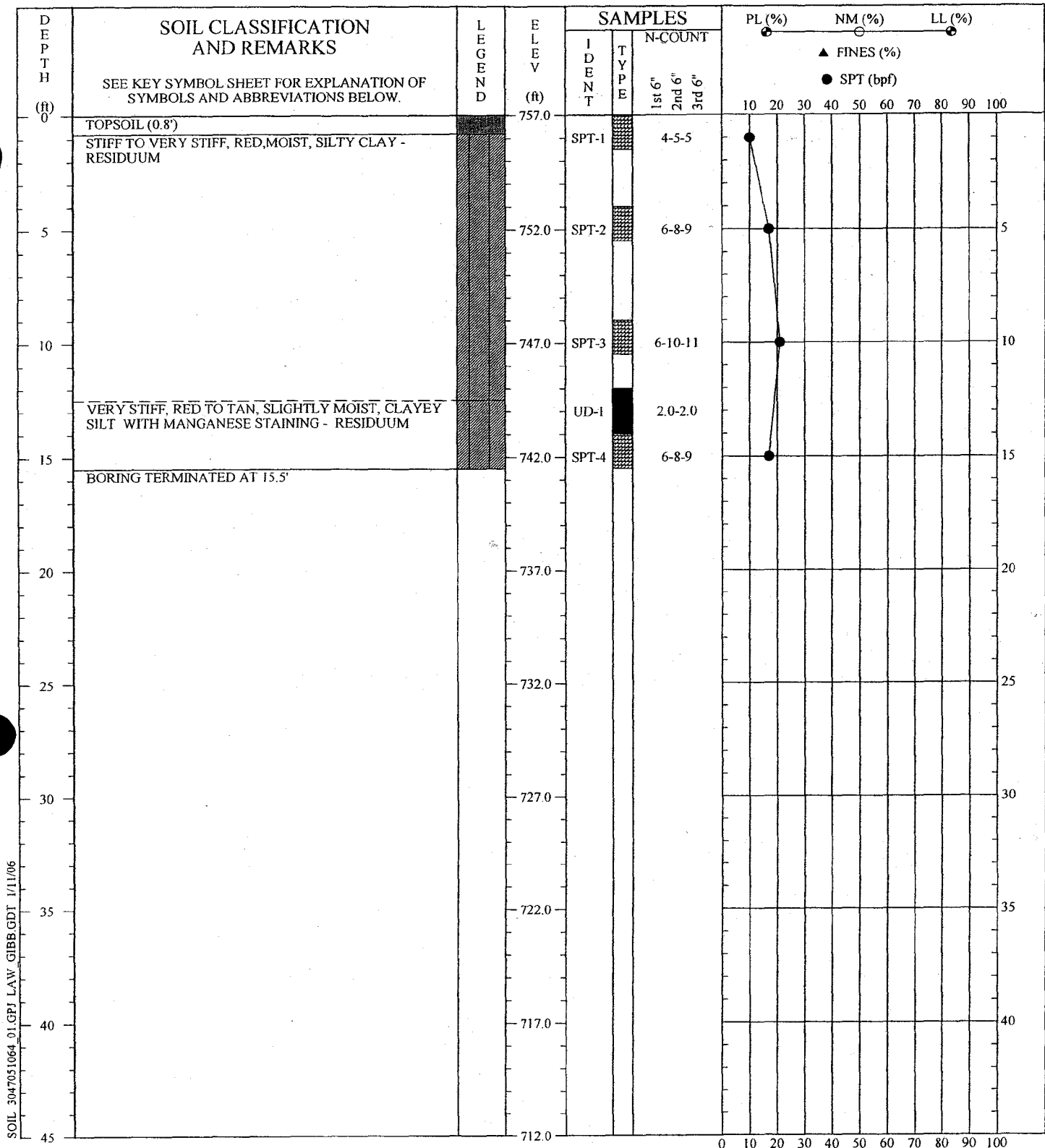

SOIL 3047051064 01.GPJ LAW GIBB.GDT 1/11/06

REMARKS: STANDARD PENETRATION RESISTANCE TESTING PERFORMED USING AN AUTOMATIC HAMMER. NO GROUND WATER ENCOUNTERED AT TIME OF EXPLORATION.

**SOIL TEST BORING RECORD**

**PROJECT:** TVA Kingston  
**DRILLED:** November 22, 2005      **BORING NO.:** K-14  
**PROJ. NO.:** 3043051064/0001      **PAGE 1 OF 1**

THIS RECORD IS A REASONABLE INTERPRETATION OF SUBSURFACE CONDITIONS AT THE EXPLORATION LOCATION. SUBSURFACE CONDITIONS AT OTHER LOCATIONS AND AT OTHER TIMES MAY DIFFER. INTERFACES BETWEEN STRATA ARE APPROXIMATE. TRANSITIONS BETWEEN STRATA MAY BE GRADUAL.

Driller : Marshall  
 Prepared By: M.O.  
 Checked By: *[Signature]*



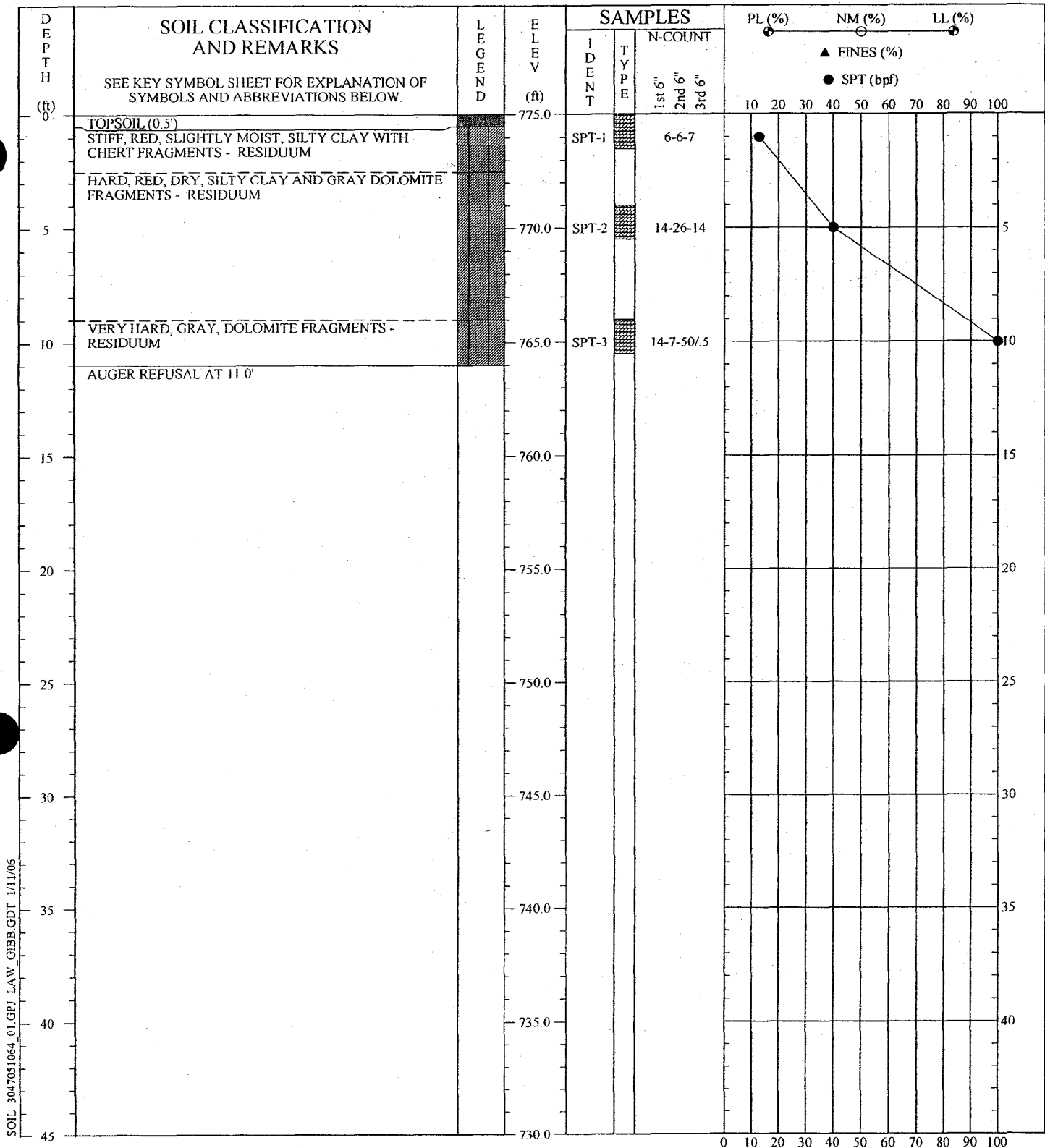

SOIL 3047051064 01.GPJ LAW\_GIBB.GDT 1/11/06

REMARKS: STANDARD PENETRATION RESISTANCE TESTING PERFORMED USING AN AUTOMATIC HAMMER. NO GROUND WATER ENCOUNTERED AT TIME OF EXPLORATION.

**SOIL TEST BORING RECORD**

**PROJECT:** TVA Kingston  
**DRILLED:** November 22, 2005      **BORING NO.:** K-15  
**PROJ. NO.:** 3043051064/0001      **PAGE 1 OF 1**

THIS RECORD IS A REASONABLE INTERPRETATION OF SUBSURFACE CONDITIONS AT THE EXPLORATION LOCATION. SUBSURFACE CONDITIONS AT OTHER LOCATIONS AND AT OTHER TIMES MAY DIFFER. INTERFACES BETWEEN STRATA ARE APPROXIMATE. TRANSITIONS BETWEEN STRATA MAY BE GRADUAL.

Driller: Marshall  
 Prepared By: M.O.  
 Checked By: *MO*





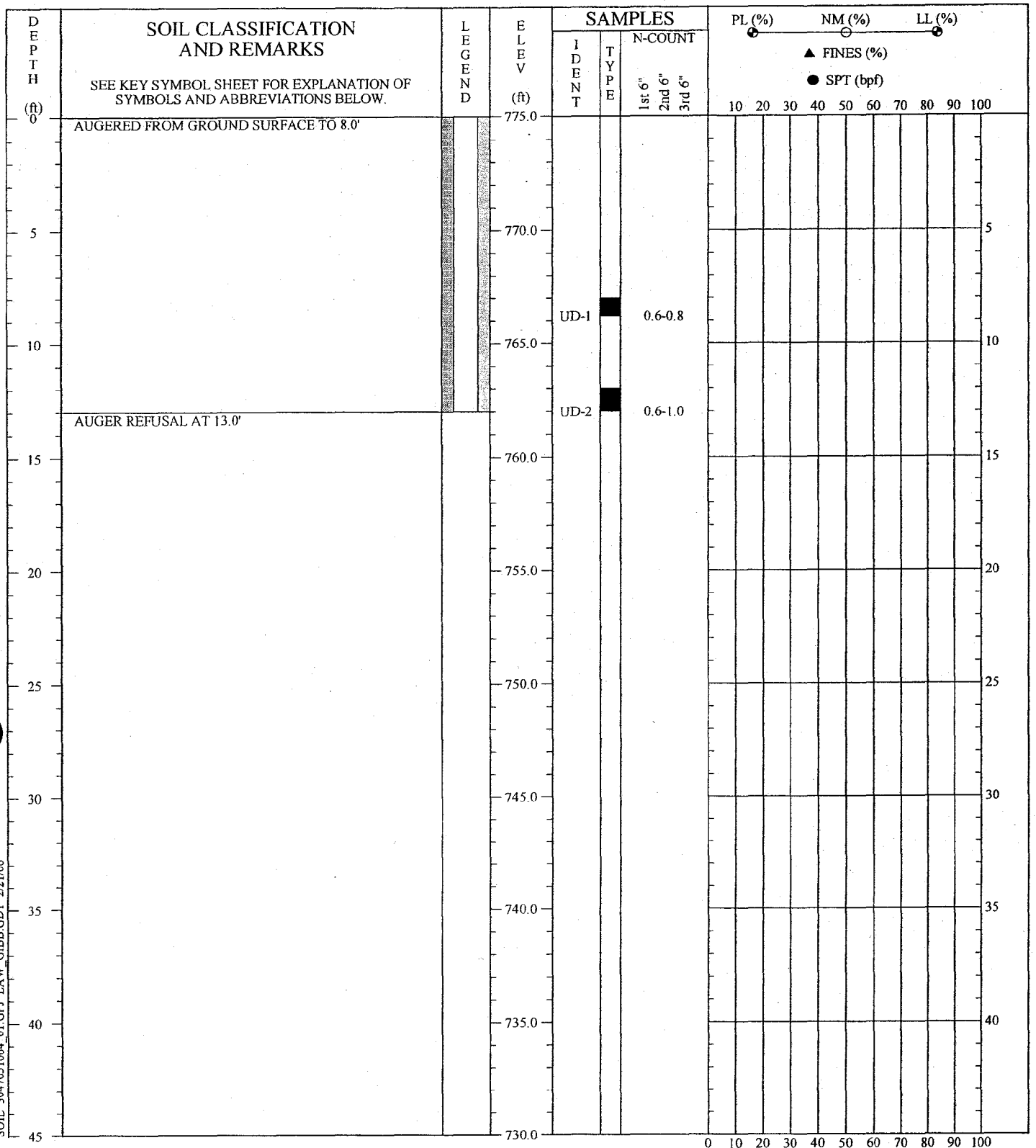

SOIL 3047051064 01.GPJ LAW\_GIBB.GDT 2/21/06

REMARKS: NO GROUND WATER ENCOUNTERED AT TIME OF EXPLORATION.

SOIL TEST BORING RECORD	
<b>PROJECT:</b> TVA Kingston	<b>BORING NO.:</b> K-15A
<b>DRILLED:</b> November 22, 2005	<b>PAGE 1 OF 1</b>
<b>PROJ. NO.:</b> 3043051064/0001	
Driller : Marshall	Prepared By: M.O.
Checked By: <i>[Signature]</i>	

THIS RECORD IS A REASONABLE INTERPRETATION OF SUBSURFACE CONDITIONS AT THE EXPLORATION LOCATION. SUBSURFACE CONDITIONS AT OTHER LOCATIONS AND AT OTHER TIMES MAY DIFFER. INTERFACES BETWEEN STRATA ARE APPROXIMATE. TRANSITIONS BETWEEN STRATA MAY BE GRADUAL.

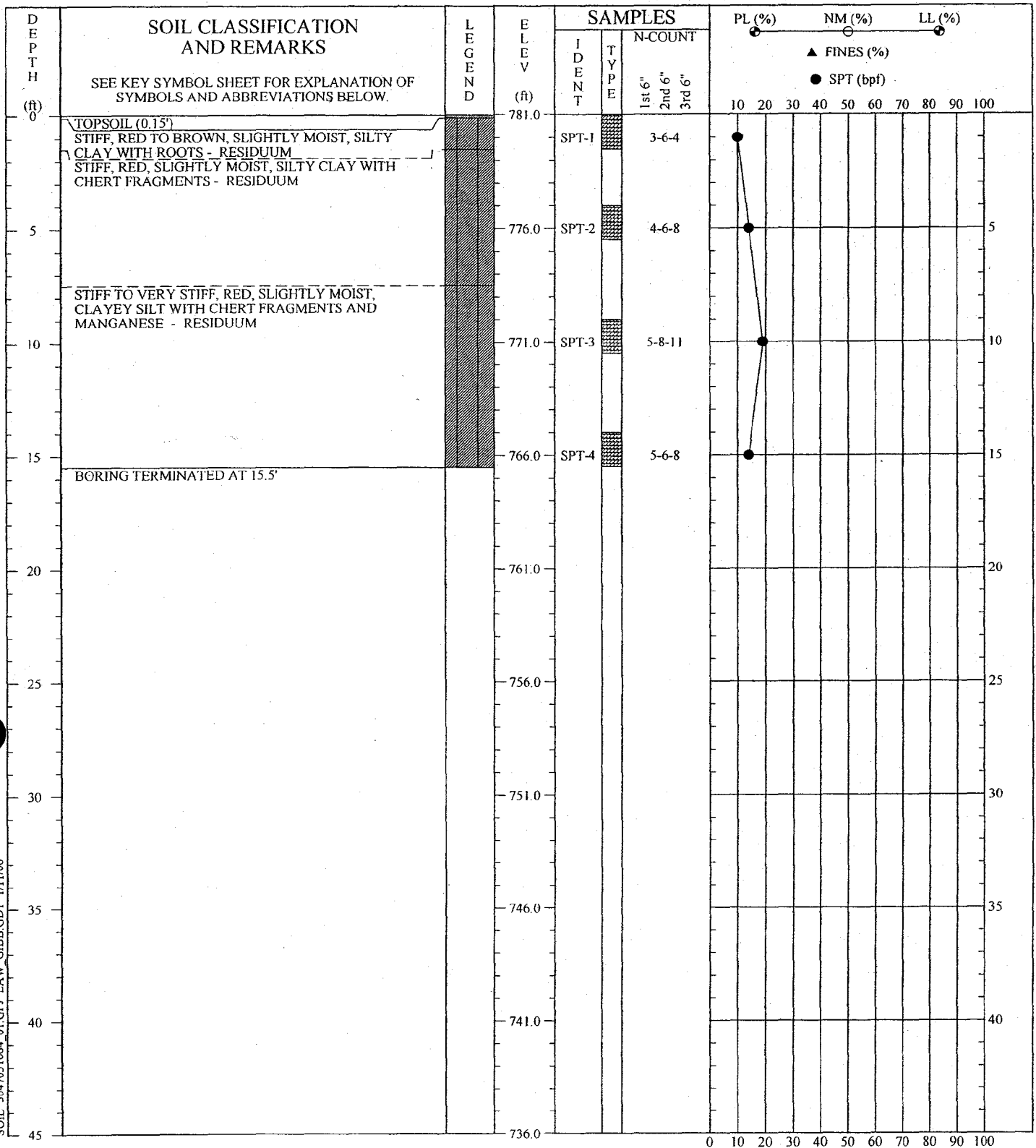

SOIL 3047051064 01.GPJ LAW GIBB.GDT 1/11/06

REMARKS: STANDARD PENETRATION RESISTANCE TESTING PERFORMED USING AN AUTOMATIC HAMMER. NO GROUND WATER ENCOUNTERED AT TIME OF EXPLORATION.

SOIL TEST BORING RECORD	
<b>PROJECT:</b> TVA Kingston	<b>BORING NO.:</b> K-16
<b>DRILLED:</b> November 16, 2005	<b>PROJ. NO.:</b> 3043051064/0001
<b>PREPARED BY:</b> M.O.	<b>CHECKED BY:</b> <i>[Signature]</i>
	

THIS RECORD IS A REASONABLE INTERPRETATION OF SUBSURFACE CONDITIONS AT THE EXPLORATION LOCATION. SUBSURFACE CONDITIONS AT OTHER LOCATIONS AND AT OTHER TIMES MAY DIFFER. INTERFACES BETWEEN STRATA ARE APPROXIMATE. TRANSITIONS BETWEEN STRATA MAY BE GRADUAL.

Driller : Marshall  
Prepared By: M.O.  
Checked By: *[Signature]*

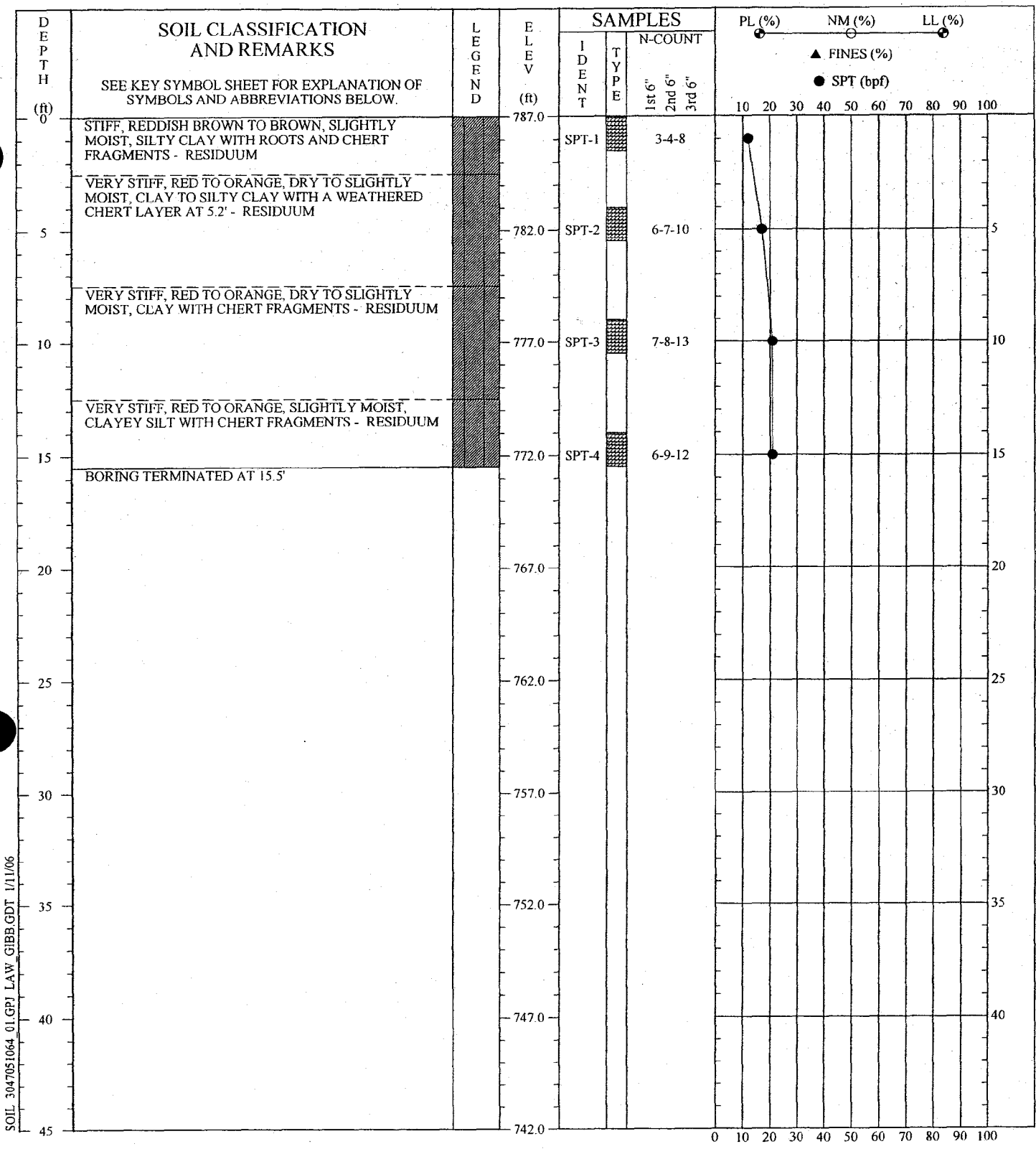

SOIL 3043051064\_01.GPJ LAW: GIBB.GDT 1/11/06

REMARKS: STANDARD PENETRATION RESISTANCE TESTING PERFORMED USING AN AUTOMATIC HAMMER. NO GROUND WATER ENCOUNTERED AT TIME OF EXPLORATION.

**SOIL TEST BORING RECORD**

**PROJECT:** TVA Kingston  
**DRILLED:** November 16, 2005      **BORING NO.:** K-17  
**PROJ. NO.:** 3043051064/0001      **PAGE 1 OF 1**

THIS RECORD IS A REASONABLE INTERPRETATION OF SUBSURFACE CONDITIONS AT THE EXPLORATION LOCATION. SUBSURFACE CONDITIONS AT OTHER LOCATIONS AND AT OTHER TIMES MAY DIFFER. INTERFACES BETWEEN STRATA ARE APPROXIMATE. TRANSITIONS BETWEEN STRATA MAY BE GRADUAL.

Driller : Marshall  
 Prepared By: M.O.  
 Checked By: *[Signature]*



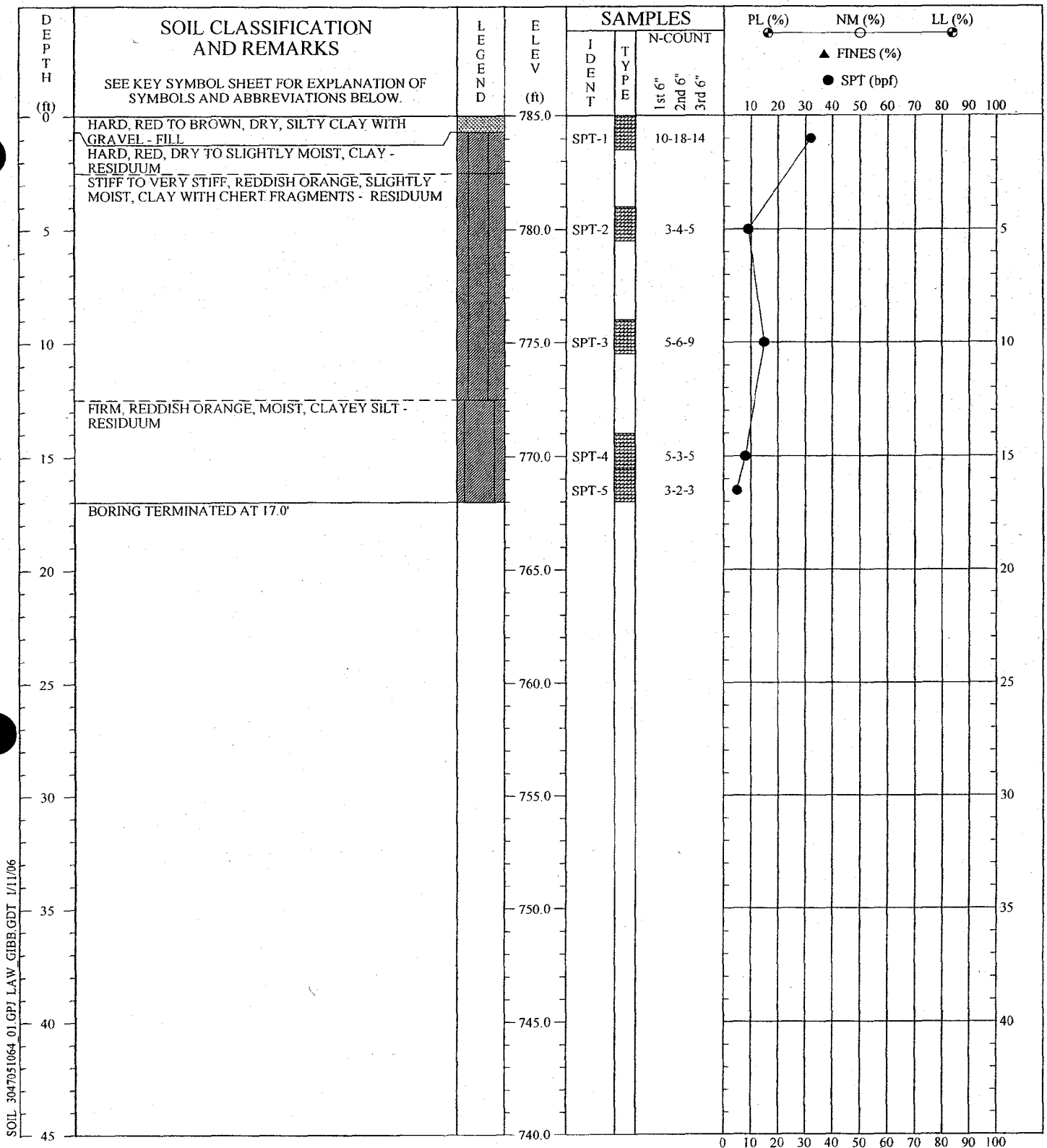

SOIL 3047051064 01.GPJ LAW\_GIBB.GDT 1/11/06

REMARKS: STANDARD PENETRATION RESISTANCE TESTING PERFORMED USING AN AUTOMATIC HAMMER. NO GROUND WATER ENCOUNTERED AT TIME OF EXPLORATION.

**SOIL TEST BORING RECORD**

**PROJECT:** TVA Kingston  
**DRILLED:** November 16, 2005      **BORING NO.:** K-18  
**PROJ. NO.:** 3043051064/0001      **PAGE 1 OF 1**

THIS RECORD IS A REASONABLE INTERPRETATION OF SUBSURFACE CONDITIONS AT THE EXPLORATION LOCATION. SUBSURFACE CONDITIONS AT OTHER LOCATIONS AND AT OTHER TIMES MAY DIFFER. INTERFACES BETWEEN STRATA ARE APPROXIMATE. TRANSITIONS BETWEEN STRATA MAY BE GRADUAL.

Driller: Marshall  
 Prepared By: M.O.  
 Checked By: *[Signature]*



**APPENDIX C**

**MONITORING WELL INSTALLATION LOGS**

# OVERBURDEN MONITORING WELL INSTALLATION RECORD

JOB NAME TVA KINGSTON GYPSUM DISPOSAL AREA

JOB NUMBER 3043051064.01

TVA WELL NUMBER MW-M

INSTALLATION DATE 01/16/2006

BOREHOLE DIAMETER 7.25" (SOIL)

DRILLED BY G. AKINS

TOTAL DEPTH 35.0'

RISER/SCREEN SCHEDULE 40 PVC

FIELD REPRESENTATIVE T. JUSTICE

MATERIAL SCHEDULE 40 PVC

DIAMETER 2.0"

SLOT SIZE 0.010"

*CTJ*

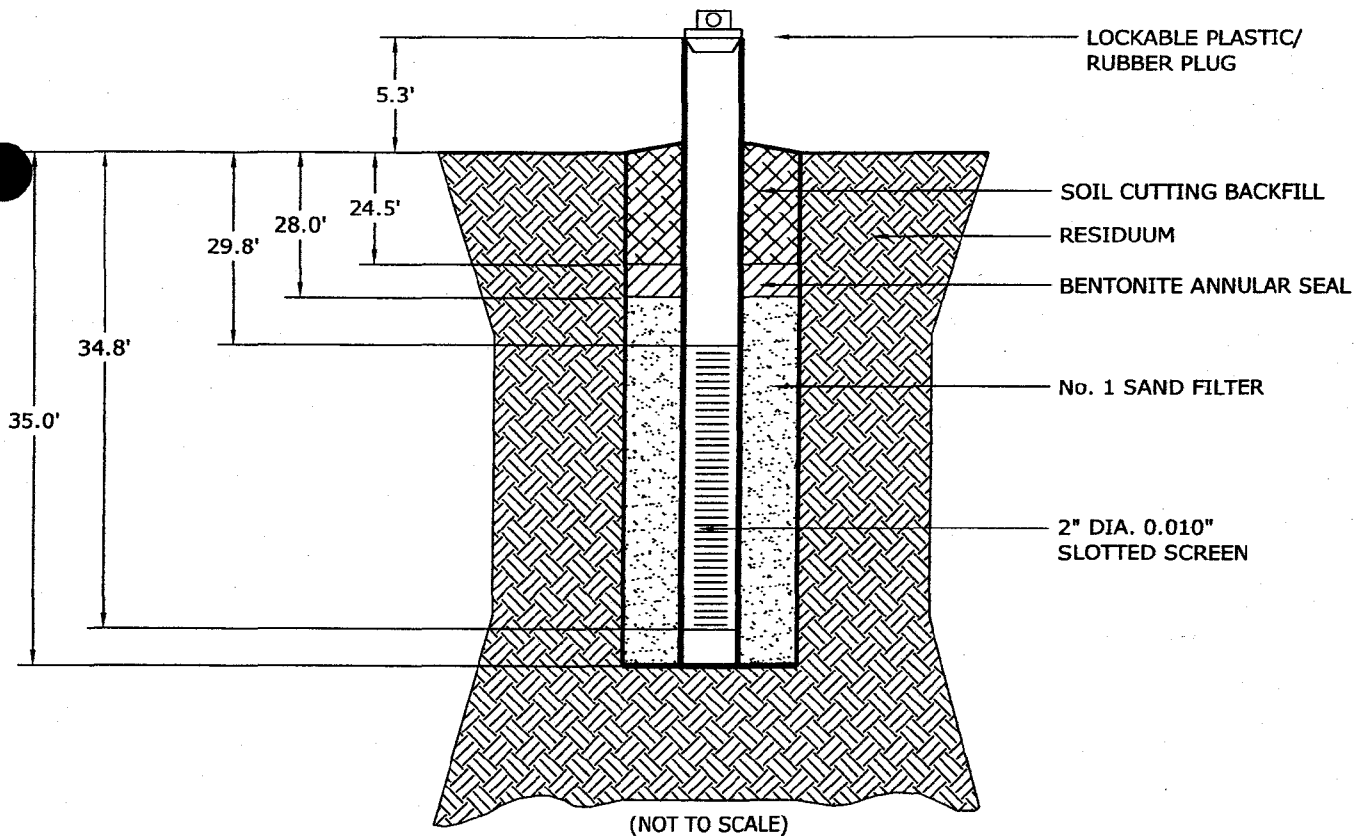

**MACTEC**

# OVERBURDEN MONITORING WELL INSTALLATION RECORD

JOB NAME TVA KINGSTON GYPSUM DISPOSAL AREA

JOB NUMBER 3043051064.01

TVA WELL NUMBER MW-N

INSTALLATION DATE 01/12/2006

BOREHOLE DIAMETER 7.25" (SOIL)

DRILLED BY G. AKINS

TOTAL DEPTH 25.5'

RISER/SCREEN SCHEDULE 40 PVC

FIELD REPRESENTATIVE T. JUSTICE

MATERIAL SCHEDULE 40 PVC

DIAMETER 2.0"

SLOT SIZE 0.010"

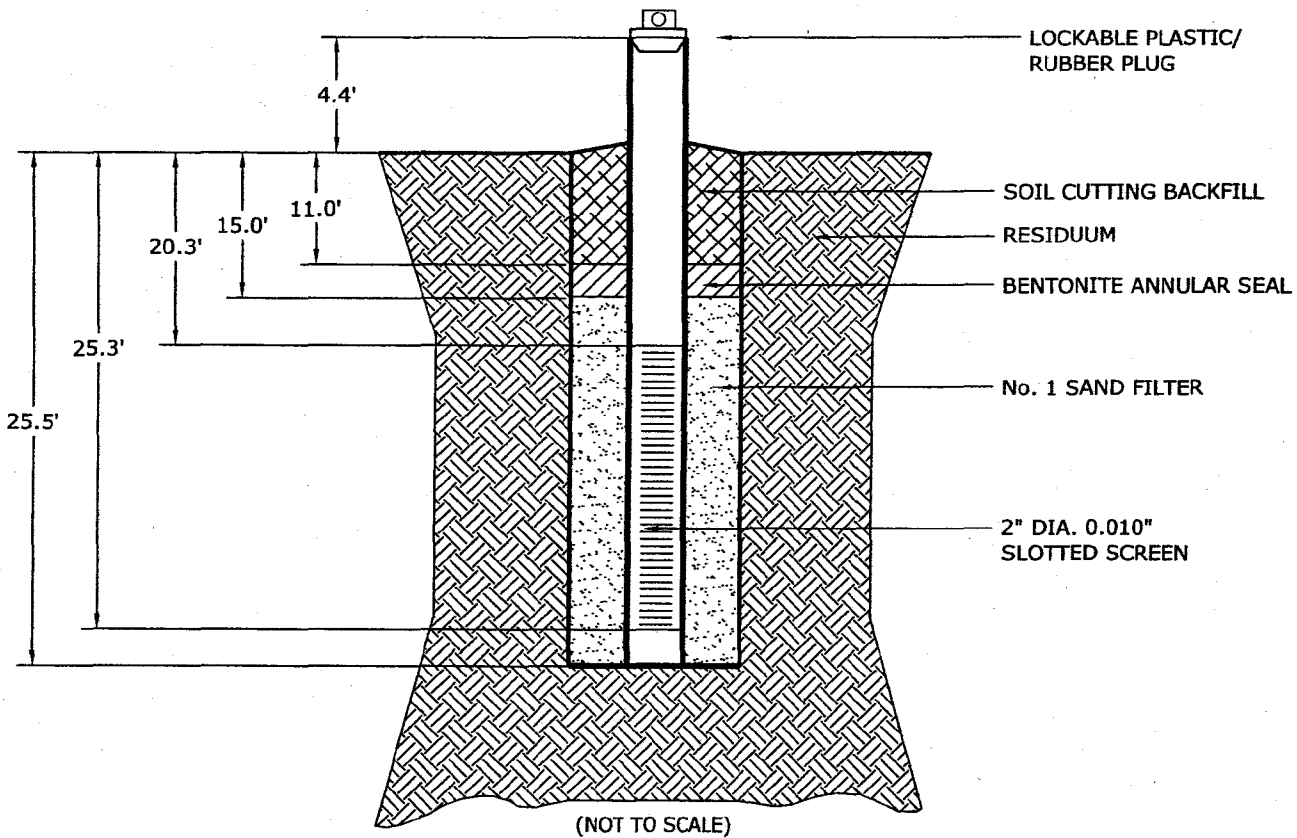

MACTEC

# BEDROCK MONITORING WELL INSTALLATION RECORD

JOB NAME TVA KINGSTON GYPSUM DISPOSAL AREA  
 TVA WELL NUMBER MW-P  
 BOREHOLE DIAMETER 7.25" (SOIL); 3.78" (BEDROCK)  
 TOTAL DEPTH 60.5'  
 FIELD REPRESENTATIVE T. JUSTICE

JOB NUMBER 3043051064.01  
 INSTALLATION DATE 01/16/2006  
 DRILLED BY G. AKINS  
 RISER/SCREEN MATERIAL SCHEDULE 40 PVC  
 DIAMETER 2.0"  
 SLOT SIZE 0.010"

*CTA*

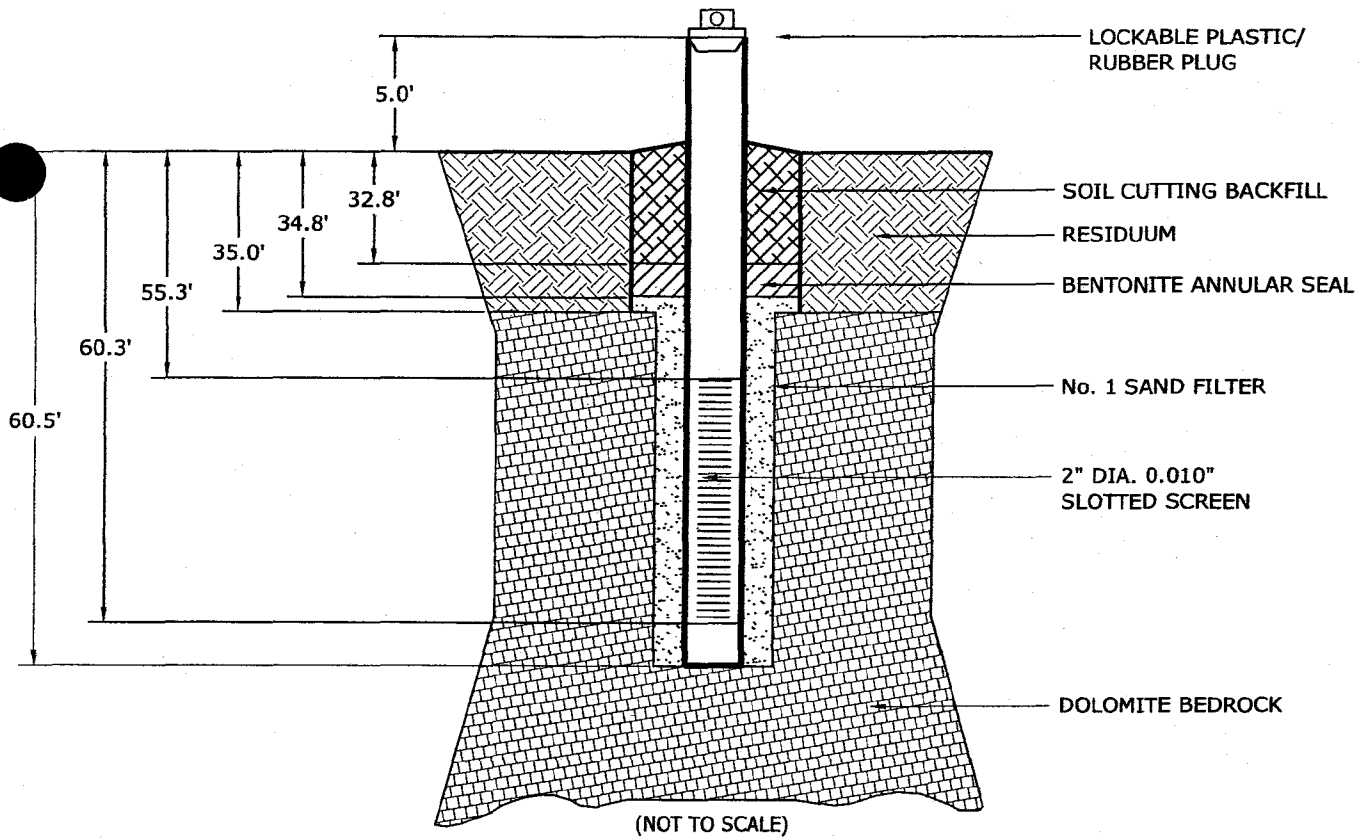



**APPENDIX D**

**LABORATORY TEST PROCEDURES**

**TABLES**

**LABORATORY TEST RESULTS**

## LABORATORY TEST PROCEDURES

### Moisture Content

The moisture content in a given mass of soil is the ratio, expressed as a percentage, of the weight of the water to the weight of the solid particles. This test was conducted in accordance with ASTM D-2216.

### Atterberg Limits (Plasticity Index)

Originally, the Atterberg Limits consisted of seven "limits of consistency" of fine-grained soils. In current engineering usage, the term usually refers only to the liquid limit (LL) and plastic limit (PL). The LL (between the liquid and plastic states) is the water content at which a trapezoidal groove of specified shape, cut in moist soil held in a special cup, is closed after 25 taps on a hard rubber plate. The PL (between plastic and semi-solid states) is the water content at which the soil crumbles when rolled into threads of 1/8-inch in diameter.

The LL has been found to be proportional to the compressibility of the normally consolidated soil. The Plasticity Index (PI) is the calculated difference in water contents between the LL and PL. Together the LL and PI are used to classify silts and clays according to the Unified Soils Classification System (ASTM D 2487). The PI is used to predict the potential for volume changes in confined soils beneath foundations or grade slabs. The LL, PL, and PI are determined in accordance with ASTM D 4318.

### Triaxial Shear Tests

Triaxial shear tests are used to determine the strength characteristics (cohesion and friction angle) of a given soil sample. Triaxial tests are also used to determine the elastic properties of the soil specimen.

Triaxial shear tests are performed on several sections of a relatively undisturbed sample extruded from the sampling tube or on remolded samples. The samples are trimmed into cylinders 1.4 to 2.8 inches in diameter and encased in rubber membranes. Each is then placed in a compression chamber and confined by all-around air pressure. The test results are presented in the form of

stress-strain curves and Mohr envelopes, or p-q plots on the accompanying Triaxial Shear Test Sheets.

One of three types of triaxial tests is normally performed, the most suitable type being determined by the loading conditions imposed on the soil in the field and the soil characteristics.

1. Consolidated-Undrained (Designated as a CU or R Test)
2. Consolidated-Drained (designated as a CD or S Test)
3. Unconsolidated-Undrained (designated as a UU or Q Test)

### **Grain Size Distribution**

Grain size tests are performed to aid in determining the soil classification and the grain size distribution. The soil samples are prepared for testing according to ASTM D 421 (dry preparation) or ASTM D 2217 (wet preparation). If only the grain size distribution of soils coarser than a number 200 sieve (0.074-mm opening) is desired, the grain size distribution is determined by washing the sample over a number 200 sieve and, after drying, passing the samples through a standard set of nested sieves. If the grain size distribution of the soils finer than the number 200 sieve is also desired, the grain size distribution of the soils coarser than the number 10 sieve is determined by passing the sample through a set of nested sieves. Materials passing the number 10 sieve are dispersed with a dispersing agent and suspended in water, and the grain size distribution calculated from the measured settlement rate of the particles. These tests are conducted in accordance with ASTM D 422. The percentage of clay, silt, sand, and gravel which are given on the individual particle size analysis sheets presented later in this appendix, were obtained on particle size boundaries in accordance with AASHTO M145-94 (1995).

### **Specific Gravity**

The specific gravity of soil solids is the ratio of the mass of a unit volume of a soil solids to the mass of the same volume of gas-free distilled water at 20C. The test method for determining the specific gravity of soil solids that passes the 4.75-mm (No. 4) sieve using a water pycnometer is described in ASTM D 854, Method B, "Test Methods for Specific Gravity of Soil Solids by Water Pycnometer".

### Compaction Tests (Moisture-Density Relationship)

Compaction tests are performed on representative soil samples to determine the maximum dry density and optimum moisture content. The results of the tests are used in conjunction with other tests to determine engineering properties relating to settlement, bearing capacity, shear strength, and permeability. The results may also be used as a standard to determine the percent compaction of any soil embankment.

The two most commonly used compaction tests are the standard Proctor test and the modified Proctor test. They are performed in accordance with ASTM D 698 and D 1557, respectively. Generally, the standard Proctor compaction test is run on samples from building areas and areas where moderate loads are anticipated. The modified Proctor compaction test is generally used for analyses of highways and other areas where large building loads are expected. Both tests have three procedures, depending upon soil particle size:

Test	Procedure	Hammer Weight (Pounds)	Hammer Fall (Inches)	Mold Diameter (Inches)	Screen Size (Material Finer Than)	Number of Layers	Number of Blows per Layer
Standard (D 698)	A	5.5	12	4	No. 4 sieve	3	25
	B	5.5	12	4	No. 3/8" sieve	3	25
	C	5.5	12	6	3/4" sieve	3	56
Modified (D 1557)	A	10	18	4	No. 4 sieve	5	25
	B	10	18	4	No. 3/8" sieve	5	25
	C	10	18	6	3/4" sieve	5	56

Test results are presented as a curve depicting dry unit weight versus moisture content. The compaction method used and any deviations from the recommended procedures are noted in the report.

### Unit Weights

The moist or dry unit weight of a given soil mass is obtained by dividing the weight of the soil mass by the volume. Selected portions of the Shelby tube samples obtained during the exploration were measured and weighed in our laboratory to determine sample unit weights.

### **Constant Head Permeability Test**

The test was performed on undisturbed and remolded samples. The physical dimensions and weight were obtained and the sample was encased in a rubber membrane and placed in a triaxial chamber. The sample was then back-pressure saturated until a B value of 0.95 or greater was reached. After saturation was obtained, the sample was consolidated under 10-psi confining stress, or, if requested, another confining stress. Upon completion of consolidation, a constant head permeability test was performed.

TABLE D-1  
 Index Property and Moisture-Density Test Results  
 TVA Kingston Gypsum Disposal Area - Additional Geotechnical  
 MACTEC Project 3043051064/01

Boring Number	Sample Depth (Feet)	Sample Type	Natural Moisture Content, %	Unit Weight, pcf	Atterberg Limits			Percent Finer Than No. 200 Sieve	USCS Classification	Specific Gravity	Compaction Tests	
					Liquid Limit	Plastic Limit	Plasticity Index				Std. Proctor Max. Dry Density, pcf	Opt. Moisture Content, %
NB-18*	6.5 - 18.5	UD	-	-	81	42	39	95.5	MH	2.62	-	-
NB-21A*	15 - 23	UD	-	-	53	28	25	83.8	CH	2.65	-	-
NB-21A*	30 - 38	UD	-	-	36	21	15	84.8	CL	2.66	-	-
NB-21B	31 - 33	UD	30.0	120.5	34	22	12	-	-	-	-	-
NB-21B*	31 - 33	UD	-	-	27	16	11	73.9	CL	2.69	-	-
NB-22	2 - 10	Bulk	30.7	-	40	22	18	81.1	CL	2.63	107.6	17.7
NB-25	2 - 10	Bulk	33.1	-	72	25	47	85.2	CH	2.74	95.1	26.0
NB-44*	19 - 28.5	UD	-	-	54	24	30	-	-	-	-	-
NB-47A*	9 - 17	UD	-	-	51	30	21	79.2	MH	2.72	-	-
NB-47A*	18 - 27	UD	-	-	58	34	24	62.8	MH	2.72	-	-
NB-47BA	20 - 22	UD	46.8	108.5	79	40	39	-	-	-	-	-
NB-47BA*	20 - 22	UD	-	-	80	40	40	44.1	GM	2.72	-	-
NB-73WB	40 - 42	UD	32.8	120.0	51	24	27	-	-	-	-	-
NB-73WBA	40 - 42	UD	29.6	124.3	54	24	30	-	-	-	-	-
NB-73WB*	40 - 42	UD	-	-	42	23	19	69.5	CL	2.74	-	-
NB-76	5 - 15	Bulk	25.3	-	48	28	20	70.0	ML	2.65	100.7	21.7
NB-77*	4 - 14	UD	-	-	41	25	16	55.3	CL	2.66	-	-
NB-77*	15 - 26	UD	-	-	53	29	24	57.5	MH	2.64	-	-
NB-77B	11 - 12.8	UD	28.7	118.8	50	24	26	-	-	-	-	-
NB-77B*	11 - 15	UD	-	-	49	29	20	60.7	ML	2.75	-	-
NB-77B	13 - 15	UD	30.7	118.9	75	31	44	-	-	-	-	-
NB-85A/B*	13 - 19	UD	-	-	59	30	29	45.4	SC	2.66	-	-
NB-85A/B*	23 - 29	UD	-	-	50	24	26	68.7	CH	2.64	-	-
NB-85B*	28 - 32	UD	-	-	66	28	38	54.5	CH	2.73	-	-
NB-85B	28 - 30	UD	39.0	113.3	74	36	38	-	-	-	-	-
NB-85B	30 - 32	UD	30.0	120.2	53	27	26	-	-	-	-	-
NB-90	9 - 11	UD	27.7	-	44	22	22	77.3	CL	2.73	-	-

**TABLE D-1**  
**Index Property and Moisture-Density Test Results**  
**TVA Kingston Gypsum Disposal Area - Additional Geotechnical**  
**MACTEC Project 3043051064/01**

Boring Number	Sample Depth (Feet)	Sample Type	Natural Moisture Content, %	Unit Weight, pcf	Atterberg Limits			Percent Finer Than No. 200 Sieve	USCS Classification	Specific Gravity	Compaction Tests	
					Liquid Limit	Plastic Limit	Plasticity Index				Std. Proctor Max. Dry Density, pcf	Opt. Moisture Content, %
NB-90	17 - 19	UD	24.8	-	30	21	9	54.0	CL	2.71	-	-
NB-92	11 - 13	UD	14.6	-	26	19	7	26.8	SC-SM	2.71	-	-
NB-92	1.5 - 5.5	SPT	-	-	32	21	11	-	-	-	-	-
K-1	12 - 14	UD	29.0	119.1	54	24	30	96.4	CH	2.73	-	-
K-2	12 - 14	UD	27.9	122.7	50	31	19	57.3	MH	2.67	-	-
K-3	10 - 15	Bulk	34.7	-	56	37	19	75.0	MH	2.69	92.1	27.8
K-4	12 - 14	UD	19.4	128.1	NV	NP	NP	25.2	SM	2.67	-	-
K-5	12 - 14	UD	26.6	122.2	65	39	26	45.1	MH	2.71	-	-
K-6	10 - 15	Bulk	25.6	-	43	29	14	75.0	ML	2.65	101.3	22.1
K-7	10 - 15	Bulk	22.3	-	31	21	10	70.5	CL	2.64	109.6	16.0
K-8	10 - 15	Bulk	22.4	-	51	27	24	53.0	CH	2.67	102.6	20.6
K-9	12 - 14	UD	26.9	119.0	50	28	22	75.9	CH	2.71	-	-
K-10	12 - 14	UD	26.1	123.7	47	26	21	62.7	CL	2.66	-	-
K-11	12 - 14	UD	22.9	125.8	NV	NP	NP	25.7	SM	2.71	-	-
K-12	12 - 14	UD	24.3	119.6	48	26	22	63.8	CL	2.71	-	-
K-13	12 - 14	UD	29.9	113.5	69	37	32	87.8	MH	2.69	-	-
K-14	12 - 14	UD	29.4	121.9	65	41	24	95.1	MH	2.73	-	-
K-15A	12 - 13	UD	37.3	110.3	60	42	18	66.0	MH	2.71	-	-
K-16	10 - 15	Bulk	28.3	-	52	29	23	78.9	MH	2.75	100.8	22.8
K-17	10 - 15	Bulk	30.6	-	75	40	35	89.0	MH	2.70	91.1	29.5
K-18	10 - 15	Bulk	31.3	-	71	37	34	79.4	MH	2.78	91.4	29.2

UD - Undisturbed Shelby Tube Sample

Bulk - Bulk Soil Sample

SPT - Standard Penetration Test Soil Sample

\* - Classification, Atterberg Limits, and grain size test results listed were obtained from testing performed on combined triaxial specimen samples

Prepared/Date: CTJ 02/06/06  
Checked/Date: SDS 02/21/06

**TABLE D-2**  
**Triaxial Compression Laboratory Test Results**  
**TVA Kingston Gypsum Disposal Area - Additional Geotechnical**  
**MACTEC Project 3043051064/01**

Boring Number	Sample Depth (Feet)	Sample Type	USCS Classification*	CU Triaxial Test						UU Triaxial Test			
				Average Dry Density (pcf)	Average Moisture Content (%)	Total		Effective		Average Dry Density (pcf)	Average Moisture Content (%)	Cohesion, C (psf)	Friction Angle, $\phi$ (degrees)
						Cohesion, C (psf)	Friction Angle, $\phi$ (degrees)	Cohesion, C' (psf)	Friction Angle, $\phi'$ (degrees)				
NB-18	6.5 - 18.5	UD	MH	87.6	29.4	ND	ND	ND	ND	-	-	-	-
NB-18	9 - 18.5	UD	-	-	-	-	-	-	-	79.9	38.4	ND	ND
NB-21A	15 - 23	UD	CH	91.8	28.8	760	19.9	160	34.8	91.6	29.1	ND	ND
NB-21A	30 - 38	UD	CL	92.7	27.0	ND	ND	ND	ND	-	-	-	-
NB-21B	31 - 33	UD	CL	96.4	26.8	1,071	14.8	318	31.0	-	-	-	-
NB-22	2 - 10	Bulk	CL	101.9	19.7	891	14.8	259	32.3	-	-	-	-
NB-25	2 - 10	Bulk	CH	90.4	27.5	1,081	11.6	530	24.6	-	-	-	-
NB-44	19 - 28.5	UD	-	84.1	34.0	ND	ND	ND	ND	82.9	35.0	ND	ND
NB-47A	9 - 17	UD	MH	91.1	30.1	ND	ND	ND	ND	99.2	23.8	2,200	2.9
NB-47A	18 - 27	UD	MH	85.5	31.8	ND	ND	ND	ND	91.1	28.2	ND	ND
NB-47BA	20 - 22	UD	GM	78.3	42.3	893	15.4	0	38.5	-	-	-	-
NB-73WB	40 - 42	UD	CL	98.2	27.3	1,345	11.9	256	32.8	-	-	-	-
NB-76	5 - 15	Bulk	ML	95.8	23.0	707	14.8	123	33.6	-	-	-	-
NB-77	4 - 14	UD	CL	97.1	24.6	ND	ND	ND	ND	95.0	25.6	ND	ND
NB-77	15 - 26	UD	MH	91.7	29.1	ND	ND	ND	ND	89.7	27.4	ND	ND
NB-77B	11 - 15	UD	ML	93.8	27.5	2,347	5.9	455	31.2	-	-	-	-
NB-85A/B	13 - 19	UD	SC	103.5	20.4	ND	ND	ND	ND	98.3	25.0	1,500	4.6
NB-85A/B	23 - 29	UD	CH	91.3	30.2	ND	ND	ND	ND	93.6	28.7	ND	ND
NB-85B	28 - 32	UD	CH	86.6	36.9	818	17.5	279	32.9	-	-	-	-

ND - Strength parameters were "not determined" due to suspect laboratory results

\* Classification results are based on the combined triaxial sample specimens Atterberg Limit and Grain Size laboratory test results

Prepared/Date: CTJ 02/06/06  
 Checked/Date: SDS 02/21/06



**TABLE D-3**  
**Hydraulic Conductivity Laboratory Test Results**  
**TVA Kingston Gypsum Disposal Area - Additional Geotechnical**  
**MACTEC Project 3043051064/01**

Boring Number	Sample Depth (Feet)	Sample Type	USCS Classification	Moisture Content (%)	Dry Density (pcf)	Effective Confining Pressure (psi)	Hydraulic Conductivity (cm/sec)
K-1	12 - 14	UD	CH	29.0	92.3	13.0	$8.4 \times 10^{-7}$
K-2	12 - 14	UD	MH	27.9	95.9	13.0	$1.4 \times 10^{-7}$
K-3	10 - 15	Bulk	MH	29.0	87.3	12.5	$3.0 \times 10^{-7}$
K-4	12 - 14	UD	SM	19.4	107.3	13.0	$1.2 \times 10^{-5}$
K-5	12 - 14	UD	MH	26.6	96.5	13.0	$1.5 \times 10^{-7}$
K-6	10 - 15	Bulk	ML	24.1	96.2	12.5	$7.4 \times 10^{-8}$
K-7	10 - 15	Bulk	CL	17.7	104.3	12.5	$1.4 \times 10^{-7}$
K-8	10 - 15	Bulk	CH	22.2	97.3	12.5	$2.7 \times 10^{-6}$
K-9	12 - 14	UD	CH	26.9	93.8	13.0	$1.8 \times 10^{-5}$
K-10	12 - 14	UD	CL	26.1	98.1	13.0	$9.1 \times 10^{-8}$
K-11	12 - 14	UD	SM	22.9	102.4	13.0	$9.1 \times 10^{-7}$
K-12	12 - 14	UD	CL	24.3	96.1	13.0	$7.6 \times 10^{-6}$
K-13	12 - 14	UD	MH	29.9	87.4	13.0	$1.6 \times 10^{-6}$
K-14	12 - 14	UD	MH	29.4	94.2	13.0	$1.7 \times 10^{-8}$
K-15A	12 - 13	UD	MH	37.3	80.3	13.0	$2.2 \times 10^{-8}$
K-16	10 - 15	Bulk	MH	24.6	95.7	12.5	$2.6 \times 10^{-8}$
K-17	10 - 15	Bulk	MH	31.7	86.6	12.5	$1.3 \times 10^{-8}$
K-18	10 - 15	Bulk	MH	31.6	87.1	12.5	$2.7 \times 10^{-8}$

UD = Undisturbed Shelby Tube Sample

Note: Bulk soil samples were remolded to approximately 95% of their respective standard Proctor maximum dry densities and 2% over optimum moisture content.

Prepared/Date: CTJ 02/06/08  
 Checked/Date: SDS 02/21/08

**GRAIN SIZE ANALYSIS TEST RESULTS**

# Particle Size Distribution Report ASTM D422/ASTM D1140

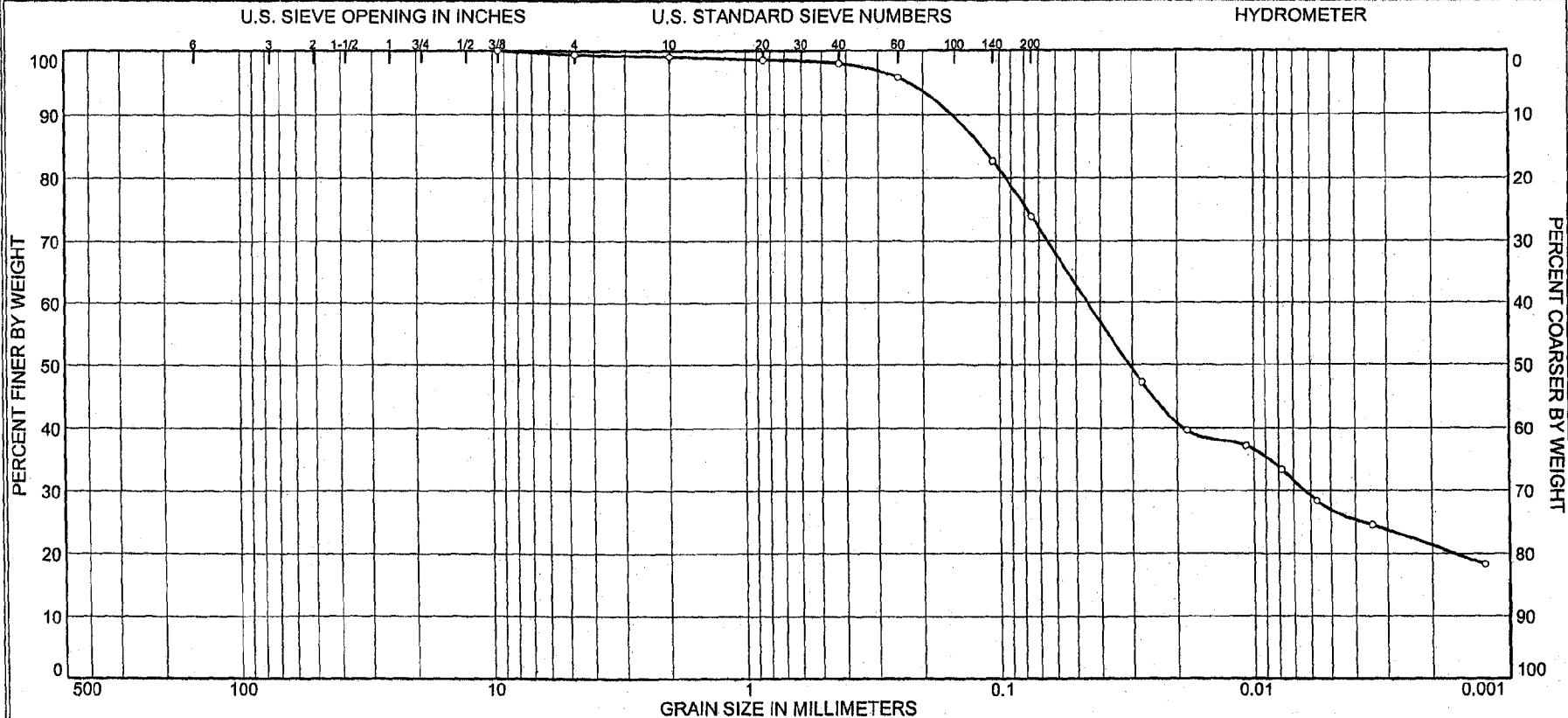

% COBBLES	% GRAVEL	% SAND	% SILT	% CLAY
0.0	0.6	25.5	47.0	26.9

SOURCE	SAMPLE #	DEPTH/ELEV.	DATE SAMPLED	USCS	MATERIAL DESCRIPTION	NM %	LL	PL
NB-21B	Composite	31 - 33	1/5/06	CL	Lean clay with sand		27	16

Client Mactec	<h2 style="margin: 0;">GeoTesting Express Inc.</h2>	Tested by: HJ	Reviewed by JW
Project TVA Kingston Proposed Gypsum Stack			
Project No. GTX G0959		Figure	

TVA-00021609

# Particle Size Distribution Report ASTM D422/ASTM D1140

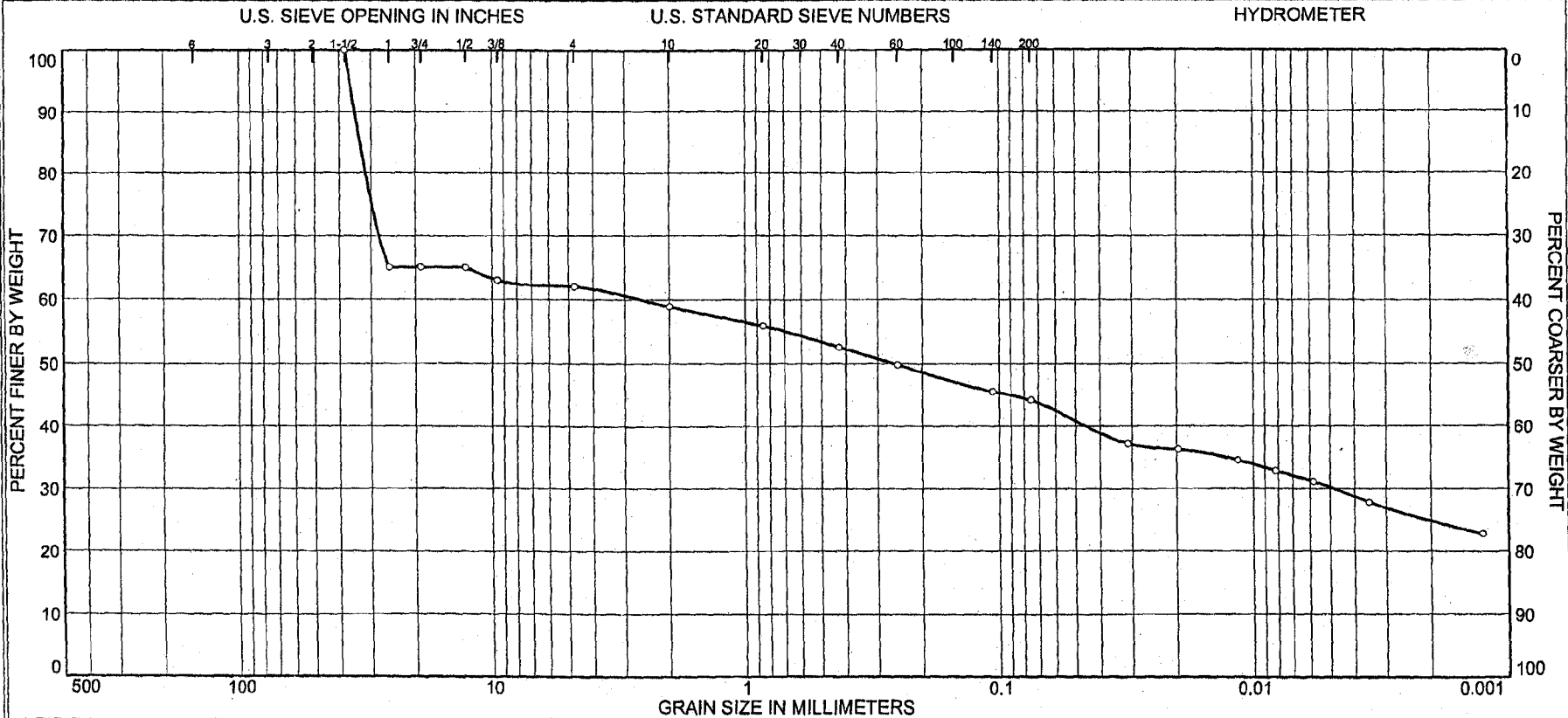

% COBBLES	% GRAVEL	% SAND	% SILT	% CLAY
0.0	38.0	17.9	13.9	30.2

SOURCE	SAMPLE #	DEPTH/ELEV.	DATE SAMPLED	USCS	MATERIAL DESCRIPTION	NM %	LL	PL
NB-47BA	Composite	20-22 Ft.	1/5/06	GM	Silty gravel with sand		80	40

Client Mactec	<h2 style="margin: 0;">GeoTesting Express Inc.</h2>	○ Tested by: HJ      Reviewed by: JW
Project TVA Kingston Proposed Gypsum Stack		
Project No. GTX G0959      Figure		

TVA-00021610



# Particle Size Distribution Report ASTM D422/ASTM D1140

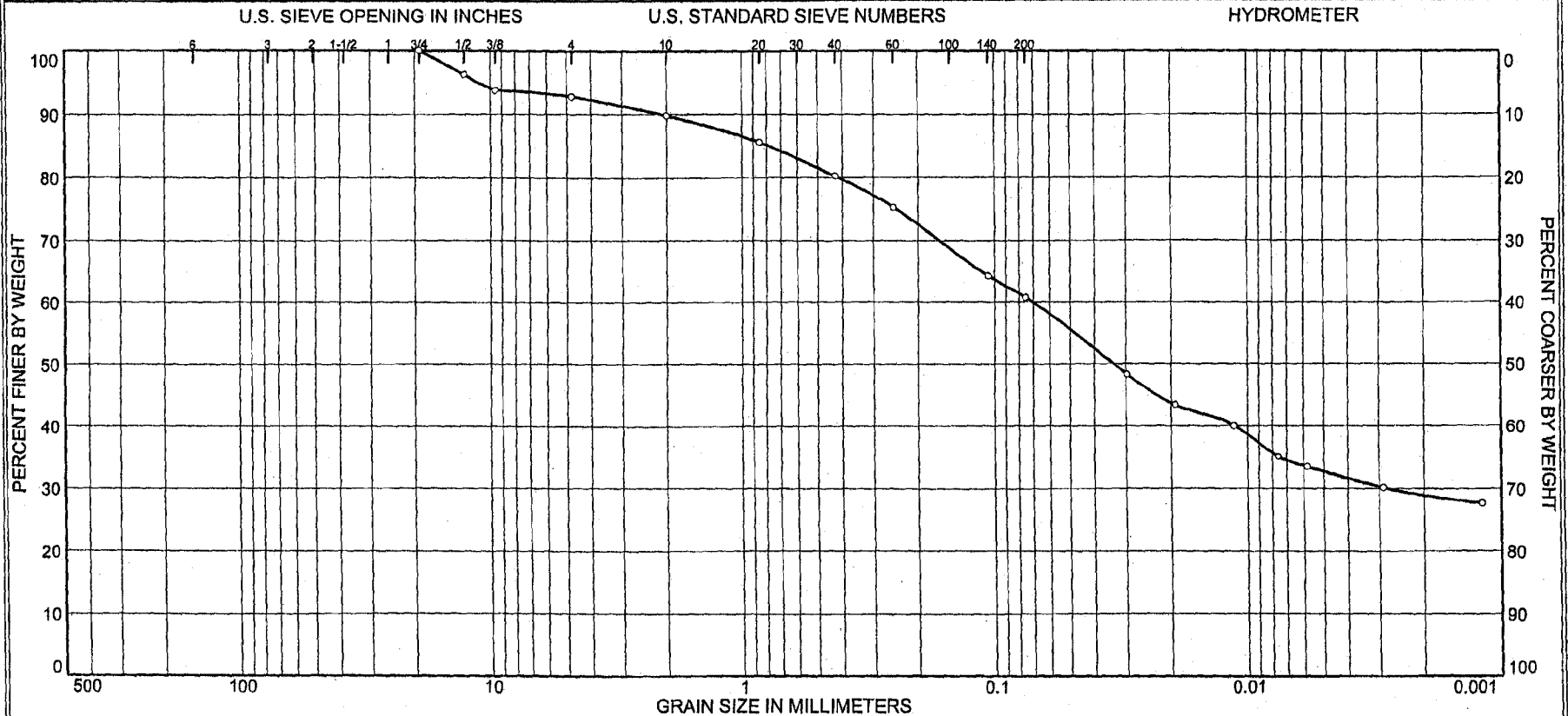

% COBBLES	% GRAVEL	% SAND	% SILT	% CLAY
0.0	7.1	32.2	28.0	32.7

SOURCE	SAMPLE #	DEPTH/ELEV.	DATE SAMPLED	USCS	MATERIAL DESCRIPTION	NM %	LL	PL
NB-77B	Ud 1 & Ud 2	Composite	12/15/05	ML	<b>SANDY SILT</b>		49	29

Client Mactec	<h2 style="margin: 0;">GeoTesting Express Inc.</h2>	○ Tested by: LJ    Reviewed by: HJ
Project TVA Kingston Proposed Gypsum Stack		
Project No. GTX G0959      Figure		

TVA-00021612

# Particle Size Distribution Report ASTM D422/ASTM D1140

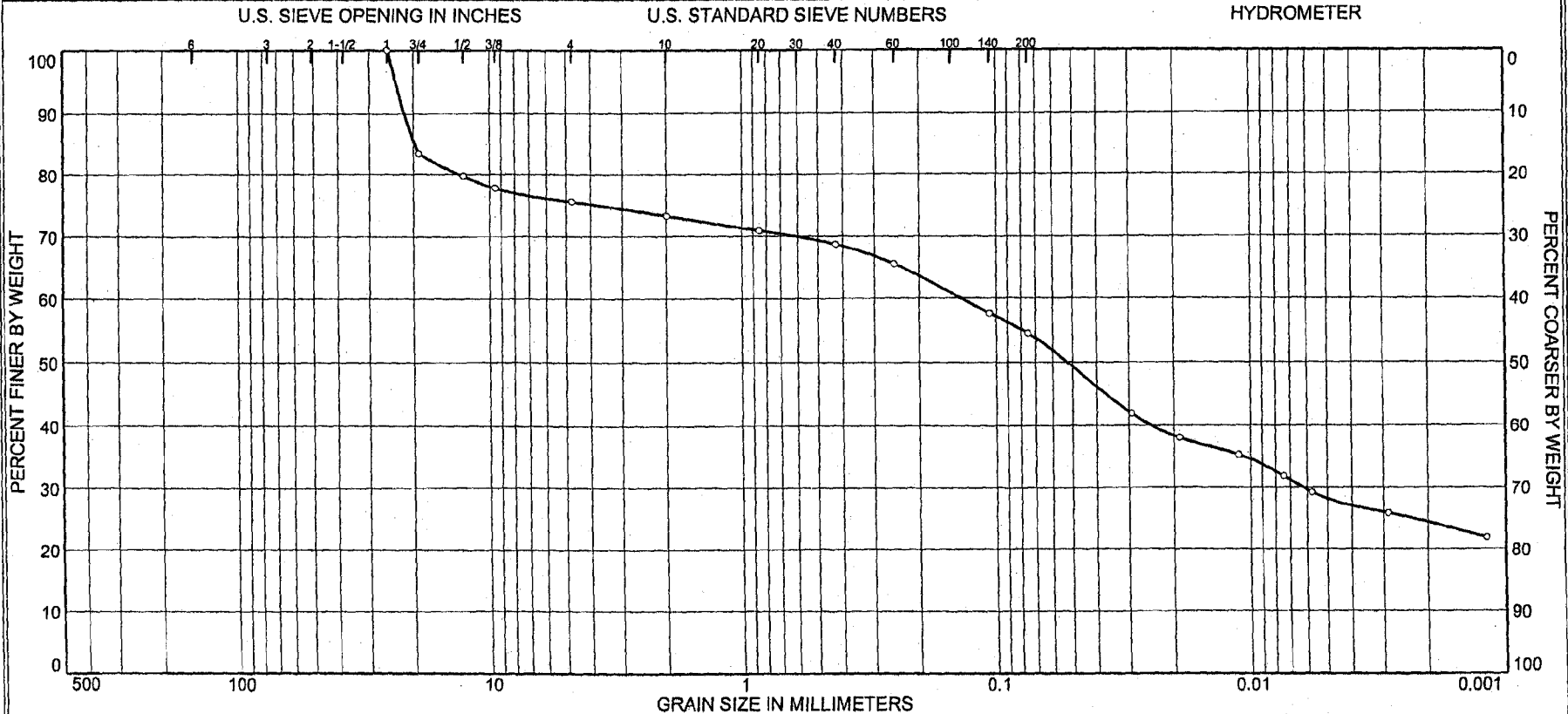

% COBBLES	% GRAVEL	% SAND	% SILT	% CLAY
0.0	24.4	21.1	26.4	28.1

SOURCE	SAMPLE #	DEPTH/ELEV.	DATE SAMPLED	USCS	MATERIAL DESCRIPTION	NM %	LL	PL
NB-85B	UD 5 & 6	Composite	12/15/05	CH	Gravelly fat clay with sand		66	28

Client Mactec Project TVA Kingston Proposed Gypsum Stack Project No. GTX G0959	<h2 style="margin: 0;">GeoTesting Express Inc.</h2>	Tested by: HJ    Reviewed by: JW
Figure		

TVA-00021613

# PARTICLE SIZE DISTRIBUTION TEST REPORT

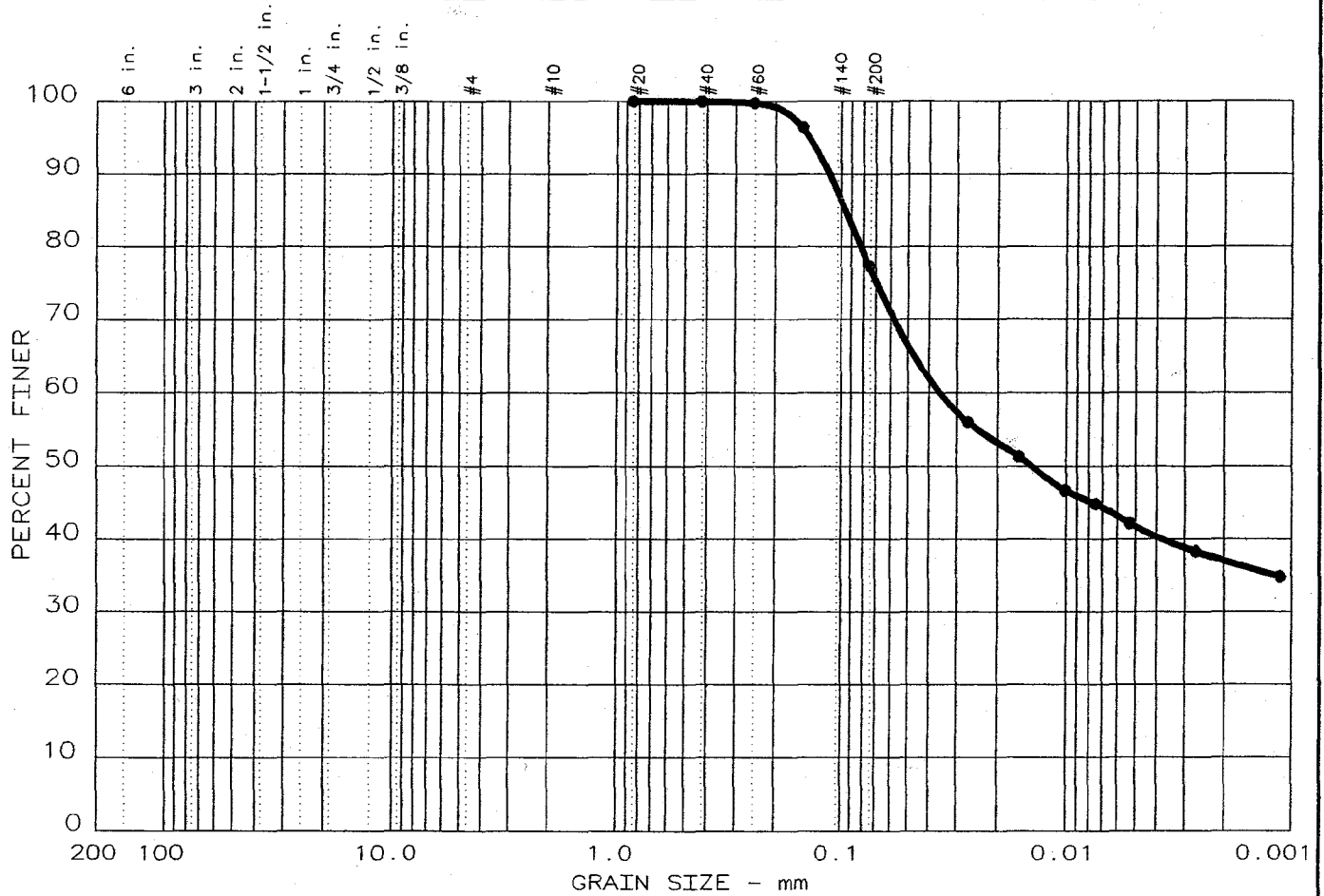

Test	% +3"	% GRAVEL	% SAND	% SILT	% CLAY	USCS	LL	PI
18	0.0	0.0	22.7	35.6	41.7	CL	44	22

SIEVE inches size	PERCENT FINER		
GRAIN SIZE			
D <sub>60</sub>	0.0359		
D <sub>30</sub>			
D <sub>10</sub>			
COEFFICIENTS			
C <sub>c</sub>			
C <sub>u</sub>			

SIEVE number size	PERCENT FINER		
	20	100.0	
40	99.9		
60	99.7		
100	96.4		
200	77.3		

Sample information:  
 • Boring NB-90, UD 9-11'  
 Orange brown to yellow  
 tan lean clay with sand

Remarks:  
 Methods: Particle Size:  
 ASTM D 422-63; Sieve  
 Analysis: AASHTO T27-99;  
 Specific Gravity: 2.73

	Project No.: 3043051064.0001
	Project: TVA Kingston- Proposed Gypsum Stack
	Date: January 23, 2006



GRAIN SIZE DISTRIBUTION TEST DATA

Test No.: 18

Date: January 23, 2006  
 Project No.: 3043051064.0001  
 Project: TVA Kingston- Proposed Gypsum Stack

Sample Data

Location of Sample: Boring NB-90, UD 9-11'  
 Sample Description 1: Orange brown to yellow  
 Sample Description 2: tan lean clay with sand  
 USCS Class: CL Liquid limit: 44 Plasticity index: 22

Notes

Remarks: Methods: Particle Size: ASTM D 422-63; Sieve  
 Analysis: AASHTO T27-99; Specific Gravity: 2.73  
 Fig. No.: B90

Mechanical Analysis Data

Initial  
 Dry sample and tare= 885.68  
 Tare = 0.00  
 Dry sample weight = 885.68  
 Sample split on number 40 sieve  
 Split sample data:  
 Sample and tare = 73.57 Tare = 0 Sample weight = 73.57  
 Cumulative weight retained tare= 0  
 Tare for cumulative weight retained= 0

Sieve	Cumul. Wt. retained	Percent finer
# 20	0.16	100.0
# 40	0.54	99.9
# 60	0.16	99.7
# 100	2.60	96.4
# 200	16.64	77.3

Hydrometer Analysis Data

Separation sieve is number 40  
 Percent -# 40 based on complete sample= 99.9  
 Weight of hydrometer sample: 74.38  
 Hygroscopic moisture correction:  
 Moist weight & tare = 52.92  
 Dry weight & tare = 52.58  
 Tare = 21.96  
 Hygroscopic moisture= 1.1 %  
 Calculated biased weight= 73.61  
 Table of composite correction values:  
 Temp, deg C: 20.0 20.5 21.0 21.5 22.0

Comp. corr: - 6.7 - 6.5 - 6.4 - 6.3 - 6.1  
 Meniscus correction only= 0  
 Specific gravity of solids= 2.734  
 Specific gravity correction factor= 0.982  
 Hydrometer type: 152H Effective depth L= 16.294964 - 0.164 x Rm

Elapsed time, min	Temp, deg C	Actual reading	Corrected reading	K	Rm	Eff. depth	Diameter mm	Percent finer
2.0	20.5	48.5	42.0	0.0132	48.5	8.3	0.0270	56.0
6.0	20.5	45.0	38.5	0.0132	45.0	8.9	0.0161	51.3
16.0	20.5	41.5	35.0	0.0132	41.5	9.5	0.0102	46.7
30.0	21.0	40.0	33.6	0.0131	40.0	9.7	0.0075	44.8
62.0	21.0	38.0	31.6	0.0131	38.0	10.1	0.0053	42.1
250.0	21.5	35.0	28.7	0.0131	35.0	10.6	0.0027	38.3
1488.0	21.0	32.5	26.1	0.0131	32.5	11.0	0.0011	34.8

-----  
 Fractional Components  
 -----

Gravel/Sand based on #4 sieve  
 Sand/Fines based on #200 sieve  
 % + 3 in. = 0.0      % GRAVEL = 0.0      % SAND = 22.7  
 % SILT = 35.6      % CLAY = 41.7

D85= 0.10    D60= 0.036    D50= 0.014





Meniscus correction only= 0  
 Specific gravity of solids= 2.71  
 Specific gravity correction factor= 0.987  
 Hydrometer type: 152H Effective depth L= 16.294964 - 0.164 x Rm

Elapsed time, min	Temp, deg C	Actual reading	Corrected reading	K	Rm	Eff. depth	Diameter mm	Percent finer
2.0	20.5	33.0	26.5	0.0133	33.0	10.9	0.0311	37.0
6.0	20.5	30.0	23.5	0.0133	30.0	11.4	0.0183	32.9
18.0	20.5	27.5	21.0	0.0133	27.5	11.8	0.0108	29.4
32.0	21.0	25.5	19.1	0.0132	25.5	12.1	0.0081	26.7
62.0	21.0	25.0	18.6	0.0132	25.0	12.2	0.0059	26.0
250.0	21.0	22.5	16.1	0.0132	22.5	12.6	0.0030	22.5
1464.0	21.0	20.5	14.1	0.0132	20.5	12.9	0.0012	19.7

-----  
 Fractional Components  
 -----

Gravel/Sand based on #4 sieve  
 Sand/Fines based on #200 sieve  
 % + 3 in. = 0.0      % GRAVEL = 0.0      % SAND = 46.0  
 % SILT = 28.5      % CLAY = 25.5

D85= 0.14    D60= 0.085    D50= 0.067  
 D30= 0.0114

# PARTICLE SIZE DISTRIBUTION TEST REPORT

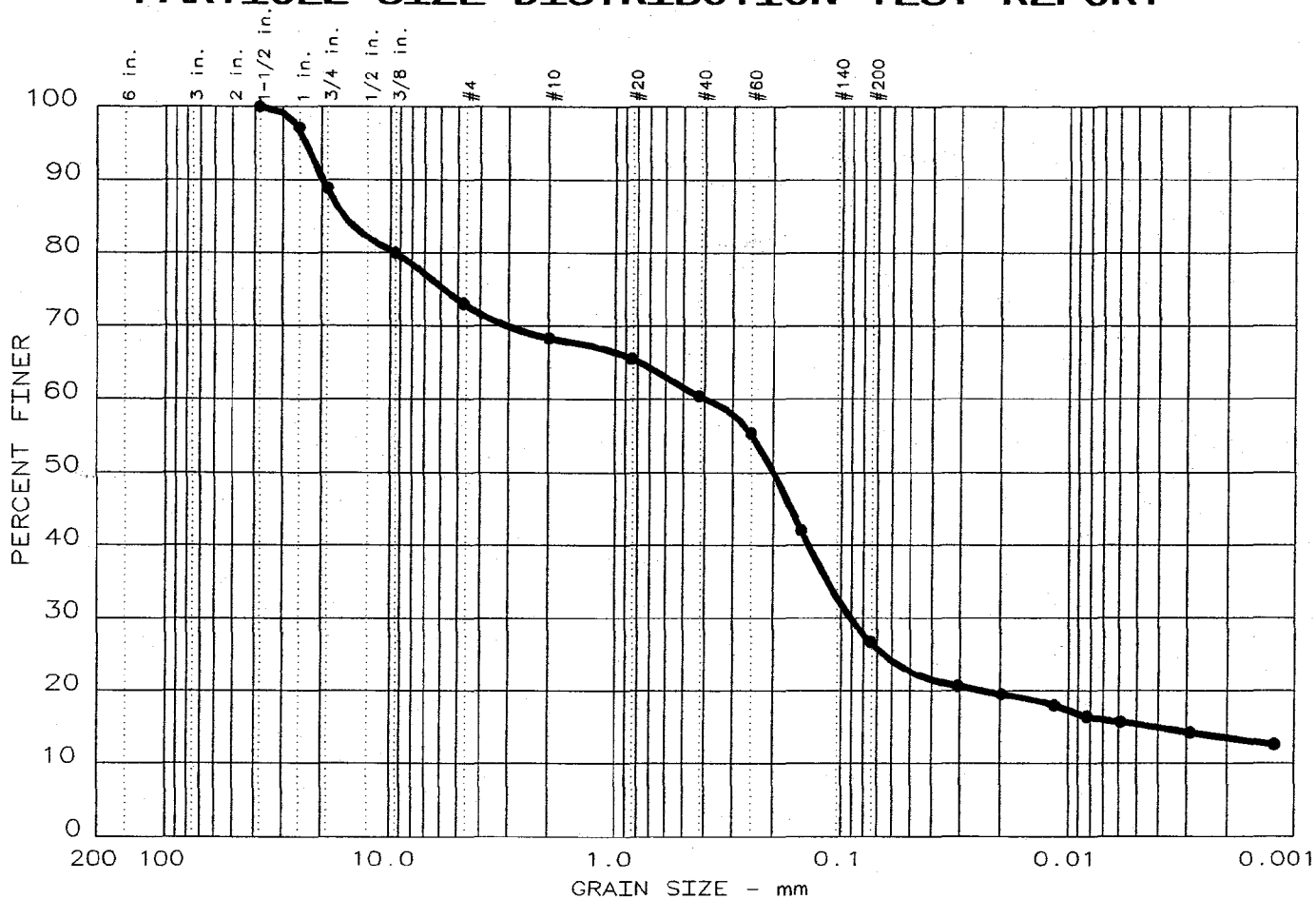

Test	% +3"	% GRAVEL	% SAND	% SILT	% CLAY	USCS	LL	PI
● 20	0.0	26.9	46.3	11.4	15.4	SC-SM	26	7

SIEVE inches size	PERCENT FINER		
	●		
1.5	100.0		
1	97.2		
0.75	88.9		
0.375	80.0		
GRAIN SIZE			
D <sub>60</sub>	0.398		
D <sub>30</sub>			
D <sub>10</sub>			
COEFFICIENTS			
C <sub>c</sub>			
C <sub>u</sub>			

SIEVE number size	PERCENT FINER		
	●		
4	73.1		
10	68.4		
20	65.6		
40	60.4		
60	55.4		
100	42.1		
200	26.8		

Sample information:  
 ● Boring NB-92, UD 11-13'  
 Red brown silty, clayey sand with gravel

Remarks:  
 Methods: Particle Size:  
 ASTM D 422-63; Sieve  
 Analysis: AASHTO T27-99;  
 Specific Gravity: 2.71

Project No.: 3043051064.0001  
 Project: TVA Kingston- Proposed Gypsum Stack  
 Date: January 23, 2006

=====

GRAIN SIZE DISTRIBUTION TEST DATA

Test No.: 20

-----

Date: January 23, 2006  
 Project No.: 3043051064.0001  
 Project: TVA Kingston- Proposed Gypsum Stack

=====

-----

Sample Data

-----

Location of Sample: Boring NB-92,UD 11-13'  
 Sample Description 1: Red brown silty, clayey  
 Sample Description 2: sand with gravel  
 JSCS Class: SC-SM      Liquid limit: 26      Plasticity index: 7

-----

Notes

-----

Remarks: Methods: Particle Size: ASTM D 422-63; Sieve  
 Analysis: AASHTO T27-99; Specific Gravity: 2.71  
 Fig. No.: B92

-----

Mechanical Analysis Data

-----

Initial  
 Dry sample and tare= 1089.89  
 Tare = 0.00  
 Dry sample weight = 1089.89  
 Sample split on number 40 sieve  
 Split sample data:  
 Sample and tare = 78.24    Tare = 0    Sample weight = 78.24  
 Cumulative weight retained tare= 0  
 Tare for cumulative weight retained= 0

Sieve	Cumul. Wt. retained	Percent finer
1.5 inches	0.00	100.0
1 inches	30.50	97.2
0.75 inches	121.10	88.9
0.375 inches	217.90	80.0
# 4	293.60	73.1
# 10	344.90	68.4
# 20	375.30	65.6
# 40	431.50	60.4
# 60	6.54	55.4
# 100	23.76	42.1
# 200	43.59	26.8

-----

Hydrometer Analysis Data

-----

Separation sieve is number 40  
 Percent -# 40 based on complete sample= 60.4  
 Weight of hydrometer sample: 78.79  
 Hygroscopic moisture correction:  
 Moist weight & tare = 53.58

Dry weight & tare = 53.35  
 Tare = 22.37  
 Hygroscopic moisture = 0.7 %  
 Calculated biased weight = 129.47  
 Table of composite correction values:  
 Temp, deg C: 20.0 21.0 21.5 22.0 23.0  
 Comp. corr: - 6.7 - 6.4 - 6.3 - 6.1 - 5.8

Meniscus correction only = 0  
 Specific gravity of solids = 2.71  
 Specific gravity correction factor = 0.987  
 Hydrometer type: 152H Effective depth L = 16.294964 - 0.164 x Rm

Elapsed time, min	Temp, deg C	Actual reading	Corrected reading	K	Rm	Eff. depth	Diameter mm	Percent finer
2.0	21.0	33.5	27.1	0.0132	33.5	10.8	0.0308	20.7
5.0	21.0	32.0	25.6	0.0132	32.0	11.0	0.0197	19.5
15.0	21.0	30.0	23.6	0.0132	30.0	11.4	0.0115	18.0
30.0	21.0	28.0	21.6	0.0132	28.0	11.7	0.0083	16.5
60.0	21.0	27.0	20.6	0.0132	27.0	11.9	0.0059	15.7
250.0	21.5	25.0	18.7	0.0132	25.0	12.2	0.0029	14.3
1443.0	21.0	23.0	16.6	0.0132	23.0	12.5	0.0012	12.7

-----  
 Fractional Components  
 -----

Gravel/Sand based on #4 sieve  
 Sand/Fines based on #200 sieve  
 % + 3 in. = 0.0      % GRAVEL = 26.9      % SAND = 46.3  
 % SILT = 11.4      % CLAY = 15.4

D85 = 15.85    D60 = 0.398    D50 = 0.197  
 D30 = 0.0902    D15 = 0.00407







Elapsed time, min	Temp, deg C	Actual reading	Corrected reading	K	Rm	Eff. depth	Diameter mm	Percent finer
0.50	22.5	50.0	45.9	0.0129	51.0	7.9	0.0515	86.5
1.00	22.5	47.5	43.4	0.0129	48.5	8.3	0.0373	81.8
2.00	22.5	44.5	40.4	0.0129	45.5	8.8	0.0272	76.1
5.00	22.5	42.0	37.9	0.0129	43.0	9.2	0.0176	71.4
15.00	22.5	39.0	34.9	0.0129	40.0	9.7	0.0104	65.8
30.00	22.5	37.0	32.9	0.0129	38.0	10.1	0.0075	62.0
60.00	22.5	35.0	30.9	0.0129	36.0	10.4	0.0054	58.2
250.00	23.0	31.0	27.0	0.0129	32.0	11.0	0.0027	50.9
1440.00	22.6	27.0	22.9	0.0129	28.0	11.7	0.0012	43.2

---

**Fractional Components**

---

Gravel/Sand based on #4

Sand/Fines based on #200

% COBBLES =

% GRAVEL =

% SAND = 3.6

% SILT = 39.0

% CLAY = 57.4

D<sub>85</sub> = 0.05    D<sub>60</sub> = 0.01    D<sub>50</sub> = 0.00





Elapsed time, min	Temp, deg C	Actual reading	Corrected reading	K	Rm	Eff. depth	Diameter mm	Percent finer
0.50	22.6	34.5	30.4	0.0131	35.5	10.5	0.0601	54.0
1.00	22.6	32.0	27.9	0.0131	33.0	10.9	0.0433	49.6
2.00	22.6	31.0	26.9	0.0131	32.0	11.0	0.0308	47.8
5.00	22.6	30.0	25.9	0.0131	31.0	11.2	0.0197	46.0
15.00	22.6	29.0	24.9	0.0131	30.0	11.4	0.0114	44.3
30.00	22.6	28.5	24.4	0.0131	29.5	11.5	0.0081	43.4
60.00	22.6	28.0	23.9	0.0131	29.0	11.5	0.0058	42.5
250.00	22.6	26.0	21.9	0.0131	27.0	11.9	0.0029	38.9
1440.00	21.9	24.0	19.7	0.0132	25.0	12.2	0.0012	35.1

---

**Fractional Components**

---

Gravel/Sand based on #4

Sand/Fines based on #200

% COBBLES =                      % GRAVEL =                      % SAND = 42.7  
 % SILT = 15.4                      % CLAY = 41.9

D85= 0.20    D60= 0.09    D50= 0.05







Effective depth  $L = 16.294964 - 0.164 \times R_m$

Elapsed time, min	Temp, deg C	Actual reading	Corrected reading	K	Rm	Eff. depth	Diameter mm	Percent finer
0.50	22.5	44.0	39.9	0.0131	45.0	8.9	0.0553	74.3
1.00	22.5	43.0	38.9	0.0131	44.0	9.1	0.0394	72.5
2.00	22.5	42.0	37.9	0.0131	43.0	9.2	0.0281	70.6
5.00	22.5	40.0	35.9	0.0131	41.0	9.6	0.0181	66.9
15.00	22.5	38.5	34.4	0.0131	39.5	9.8	0.0106	64.1
30.00	22.5	37.0	32.9	0.0131	38.0	10.1	0.0076	61.3
60.00	22.6	35.0	30.9	0.0131	36.0	10.4	0.0054	57.6
250.00	22.6	31.0	26.9	0.0131	32.0	11.0	0.0027	50.1
1440.00	22.2	29.0	24.8	0.0131	30.0	11.4	0.0012	46.2

---

Fractional Components

---

Gravel/Sand based on #4

Sand/Fines based on #200

% COBBLES =                      % GRAVEL = 3.2                      % SAND = 21.8  
% SILT = 18.4                      % CLAY = 56.6

D<sub>85</sub> = 0.23    D<sub>60</sub> = 0.01    D<sub>50</sub> = 0.00

# Particle Size Distribution Report

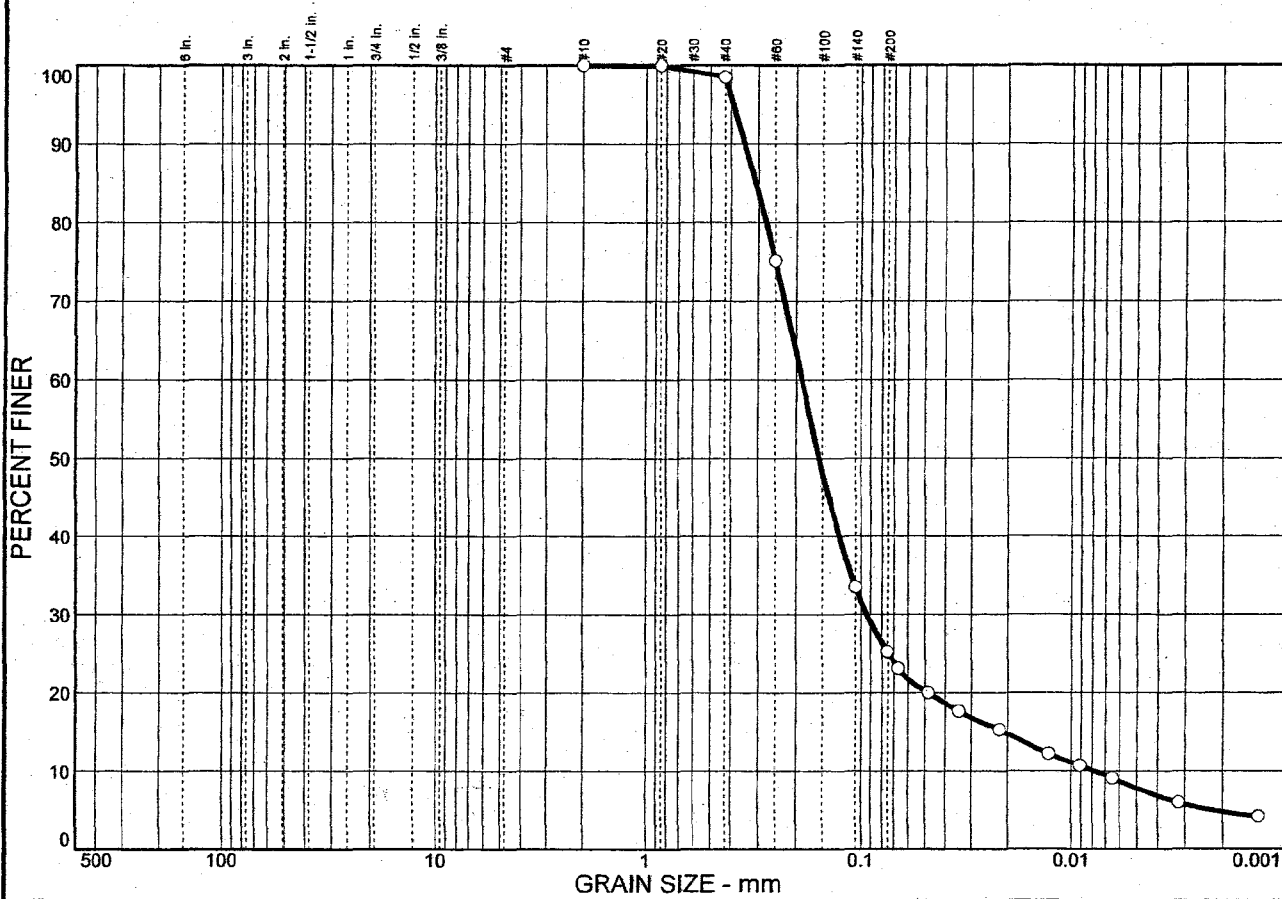

<b>% COBBLES</b>	<b>% GRAVEL</b>	<b>% SAND</b>	<b>% SILT</b>	<b>% CLAY</b>
0.0	0.0	74.8	17.3	7.9

SIEVE SIZE	PERCENT FINER	SPEC.* PERCENT	PASS? (X=NO)
#10	100.0		
#20	100.0		
#40	98.5		
#60	75.1		
#140	33.5		
#200	25.2		

**Material Description**

Silty sand

**Atterberg Limits**  
 PL= NP      LL= NV      PI= NP

**Coefficients**  
 D<sub>85</sub>= 0.309      D<sub>60</sub>= 0.188      D<sub>50</sub>= 0.155  
 D<sub>30</sub>= 0.0937      D<sub>15</sub>= 0.0207      D<sub>10</sub>= 0.0078  
 C<sub>u</sub>= 24.11      C<sub>c</sub>= 6.01

**Classification**  
 USCS= SM      AASHTO=

**Remarks**

\* (no specification provided)

Sample No.:      Source of Sample:      Date: 1-20-06  
 Location: K-4      Elev./Depth: 12'-14'

<b>MACTEC, INC.</b> Charlotte, North Carolina	Client: TVA Project: TVA Kingston - Gypsum Disposal Project No: 3043-05-1064
	Figure



Elapsed time, min	Temp, deg C	Actual reading	Corrected reading	K	Rm	Eff. depth	Diameter mm	Percent finer
0.50	22.6	19.0	14.9	0.0131	20.0	13.0	0.0670	23.1
1.00	22.6	17.0	12.9	0.0131	18.0	13.3	0.0480	20.0
2.00	22.6	15.5	11.4	0.0131	16.5	13.6	0.0343	17.6
5.00	22.6	14.0	9.9	0.0131	15.0	13.8	0.0219	15.3
15.00	22.6	12.0	7.9	0.0131	13.0	14.2	0.0128	12.2
30.00	22.6	11.0	6.9	0.0131	12.0	14.3	0.0091	10.7
60.00	22.6	10.0	5.9	0.0131	11.0	14.5	0.0065	9.1
250.00	22.6	8.0	3.9	0.0131	9.0	14.8	0.0032	6.0
1440.00	21.9	7.0	2.7	0.0133	8.0	15.0	0.0014	4.2

**Fractional Components**

Gravel/Sand based on #4

Sand/Fines based on #200

% COBBLES =                      % GRAVEL =                      % SAND = 74.8

% SILT = 17.3                      % CLAY = 7.9

D<sub>85</sub>= 0.31    D<sub>60</sub>= 0.19    D<sub>50</sub>= 0.16

D<sub>30</sub>= 0.09    D<sub>15</sub>= 0.02    D<sub>10</sub>= 0.01

C<sub>c</sub>= 6.0096    C<sub>u</sub>= 24.1106

# Particle Size Distribution Report

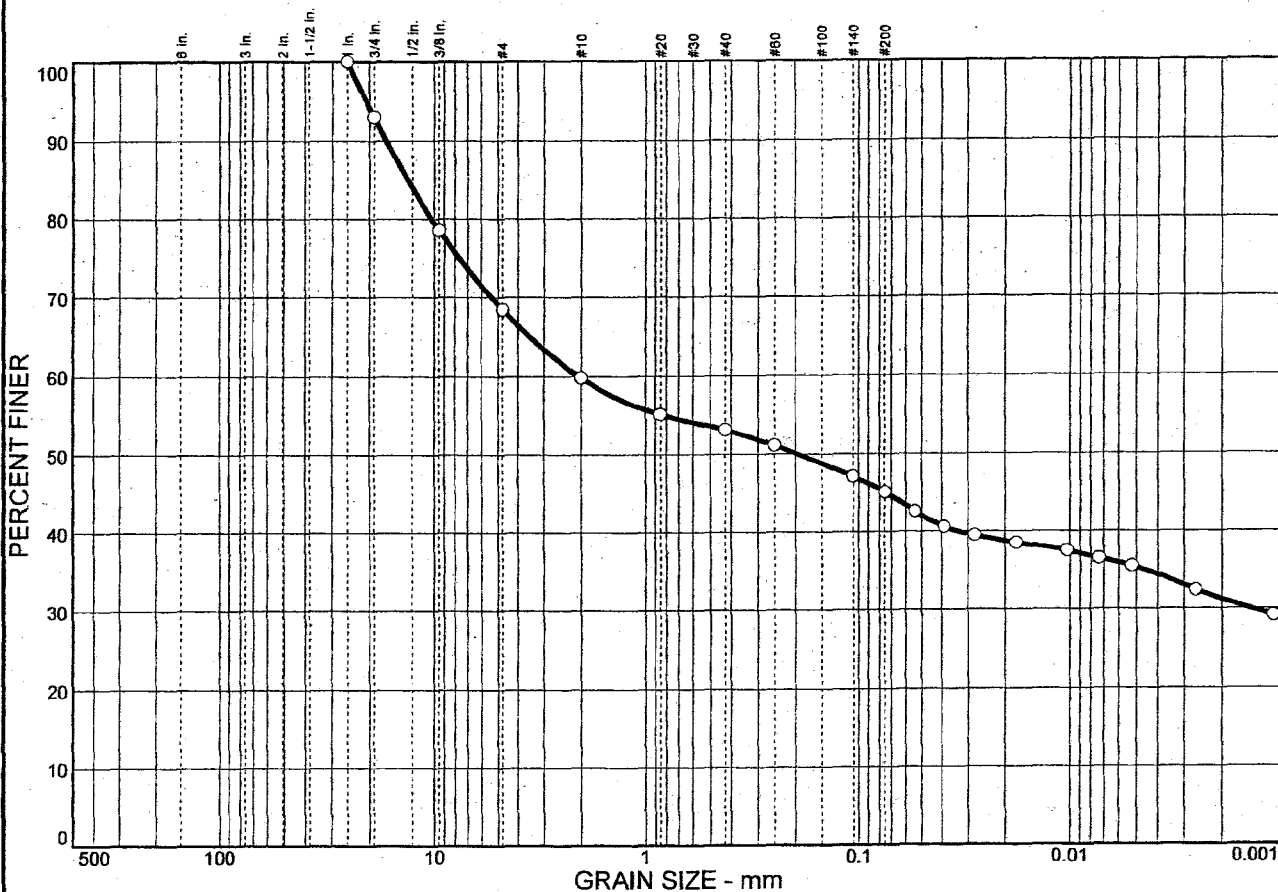

<b>% COBBLES</b>	<b>% GRAVEL</b>	<b>% SAND</b>	<b>% SILT</b>	<b>% CLAY</b>
0.0	31.5	23.4	9.8	35.3

SIEVE SIZE	PERCENT FINER	SPEC.* PERCENT	PASS? (X=NO)
1 in.	100.0		
.75 in.	93.0		
.375 in.	78.6		
#4	68.5		
#10	59.8		
#20	55.1		
#40	53.1		
#60	51.1		
#140	47.1		
#200	45.1		

**Material Description**

Silty gravel with sand

PL= 39	<b>Atterberg Limits</b>	PI= 26
	LL= 65	
	<b>Coefficients</b>	
D <sub>85</sub> = 13.3	D <sub>60</sub> = 2.05	D <sub>50</sub> = 0.194
D <sub>30</sub> = 0.0014	D <sub>15</sub> =	D <sub>10</sub> =
C <sub>u</sub> =	C <sub>c</sub> =	
	<b>Classification</b>	
USCS= GM	AASHTO=	
	<b>Remarks</b>	

\* (no specification provided)

Sample No.:  
Location: K-5

Source of Sample:

Date: 1-20-06  
Elev./Depth: 12'-14'

<p style="text-align: center;"><b>MACTEC, INC.</b></p> <p style="text-align: center;">Charlotte, North Carolina</p>	<p>Client: TVA</p> <p>Project: TVA Kingston - Gypsum Disposal</p> <p>Project No: 3043-05-1064</p>
<p>Figure</p>	



Specific gravity correction factor= 0.988

Hydrometer type: 152H

Effective depth  $L = 16.294964 - 0.164 \times R_m$

Elapsed time, min	Temp, deg C	Actual reading	Corrected reading	K	Rm	Eff. depth	Diameter mm	Percent finer
0.50	22.6	46.0	41.9	0.0130	47.0	8.6	0.0539	42.6
1.00	22.6	44.0	39.9	0.0130	45.0	8.9	0.0388	40.6
2.00	22.6	43.0	38.9	0.0130	44.0	9.1	0.0277	39.5
5.00	22.6	42.0	37.9	0.0130	43.0	9.2	0.0177	38.5
15.00	22.6	41.0	36.9	0.0130	42.0	9.4	0.0103	37.5
30.00	22.6	40.0	35.9	0.0130	41.0	9.6	0.0073	36.5
60.00	22.6	39.0	34.9	0.0130	40.0	9.7	0.0052	35.5
250.00	22.6	36.0	31.9	0.0130	37.0	10.2	0.0026	32.4
1440.00	22.0	33.0	28.7	0.0131	34.0	10.7	0.0011	29.2

**Fractional Components**

Gravel/Sand based on #4

Sand/Fines based on #200

% COBBLES =                    % GRAVEL = 31.5                    % SAND = 23.4

% SILT = 9.8                    % CLAY = 35.3

D<sub>85</sub>= 13.30    D<sub>60</sub>= 2.05    D<sub>50</sub>= 0.19

D<sub>30</sub>= 0.00

# Particle Size Distribution Report

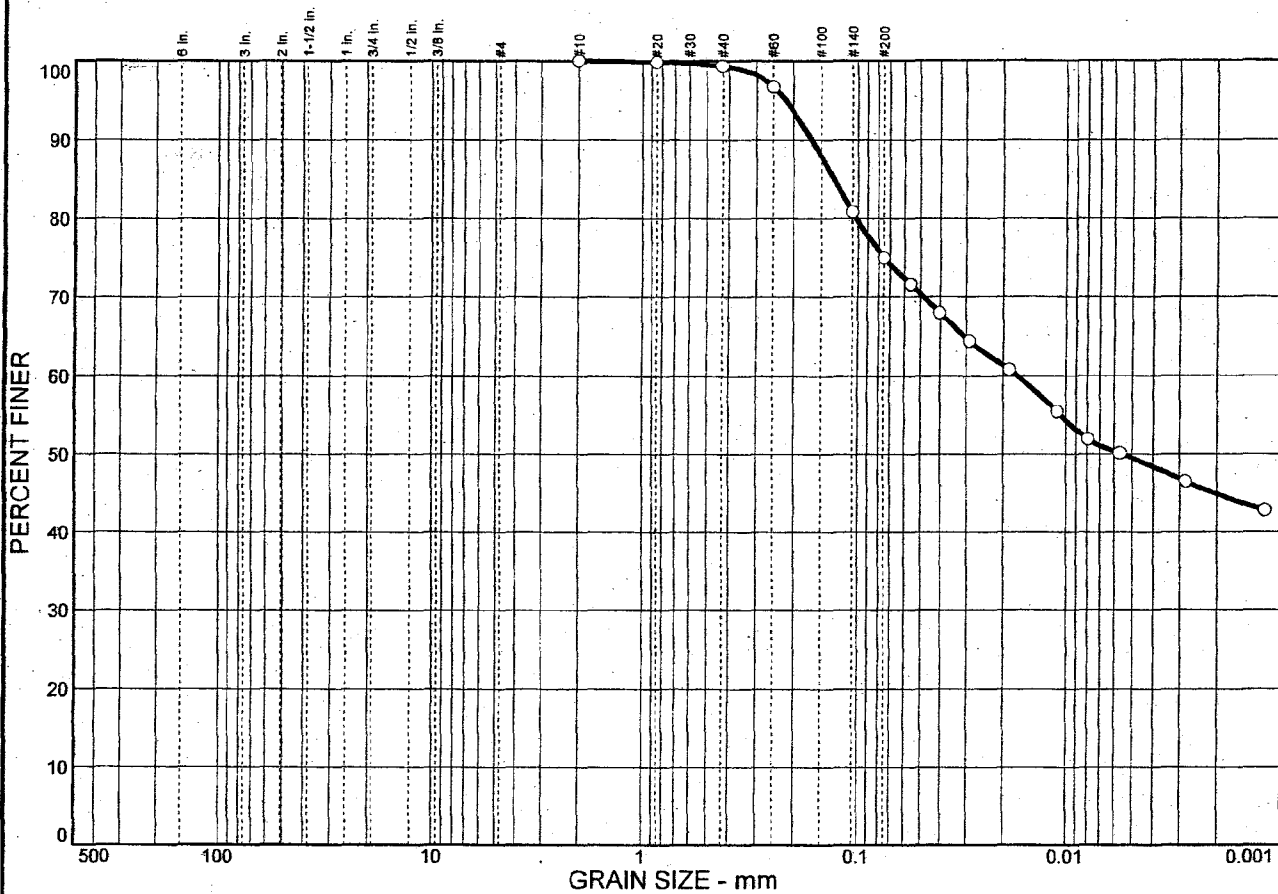

% COBBLES	% GRAVEL	% SAND	% SILT	% CLAY
0.0	0.0	25.0	25.5	49.5

SIEVE SIZE	PERCENT FINER	SPEC.* PERCENT	PASS? (X=NO)
#10	100.0		
#20	99.8		
#40	99.3		
#60	96.7		
#140	80.8		
#200	75.0		

**Material Description**

Silt with sand

**Atterberg Limits**

PL= 29      LL= 43      PI= 14

**Coefficients**

D<sub>85</sub>= 0.130      D<sub>60</sub>= 0.0170      D<sub>50</sub>= 0.0055  
D<sub>30</sub>=              D<sub>15</sub>=              D<sub>10</sub>=  
C<sub>u</sub>=              C<sub>c</sub>=

**Classification**

USCS= ML      AASHTO=

**Remarks**

\* (no specification provided)

Sample No.:  
Location: K-6

Source of Sample:

Date: 1-20-06  
Elev./Depth: 10'-15'

<p style="text-align: center;"><b>MACTEC, INC.</b></p> <p style="text-align: center;"><b>Charlotte, North Carolina</b></p>	<p>Client: TVA Project: TVA Kingston - Gypsum Disposal Project No: 3043-05-1064</p>
--	---

Figure





Elapsed time, min	Temp, deg C	Actual reading	Corrected reading	K	Rm	Eff. depth	Diameter mm	Percent finer
0.50	22.5	44.0	39.9	0.0132	45.0	8.9	0.0559	71.6
1.00	22.5	42.0	37.9	0.0132	43.0	9.2	0.0403	68.0
2.00	22.5	40.0	35.9	0.0132	41.0	9.6	0.0290	64.4
5.00	22.5	38.0	33.9	0.0132	39.0	9.9	0.0186	60.8
15.00	22.5	35.0	30.9	0.0132	36.0	10.4	0.0110	55.4
30.00	22.5	33.0	28.9	0.0132	34.0	10.7	0.0079	51.9
60.00	22.6	32.0	27.9	0.0132	33.0	10.9	0.0056	50.1
250.00	22.6	30.0	25.9	0.0132	31.0	11.2	0.0028	46.5
1440.00	22.3	28.0	23.8	0.0133	29.0	11.5	0.0012	42.8

---

**Fractional Components**

---

Gravel/Sand based on #4

Sand/Fines based on #200

% COBBLES =                      % GRAVEL =

% SAND = 25.0

% SILT = 25.5                      % CLAY = 49.5

D85= 0.13    D60= 0.02    D50= 0.01

# Particle Size Distribution Report

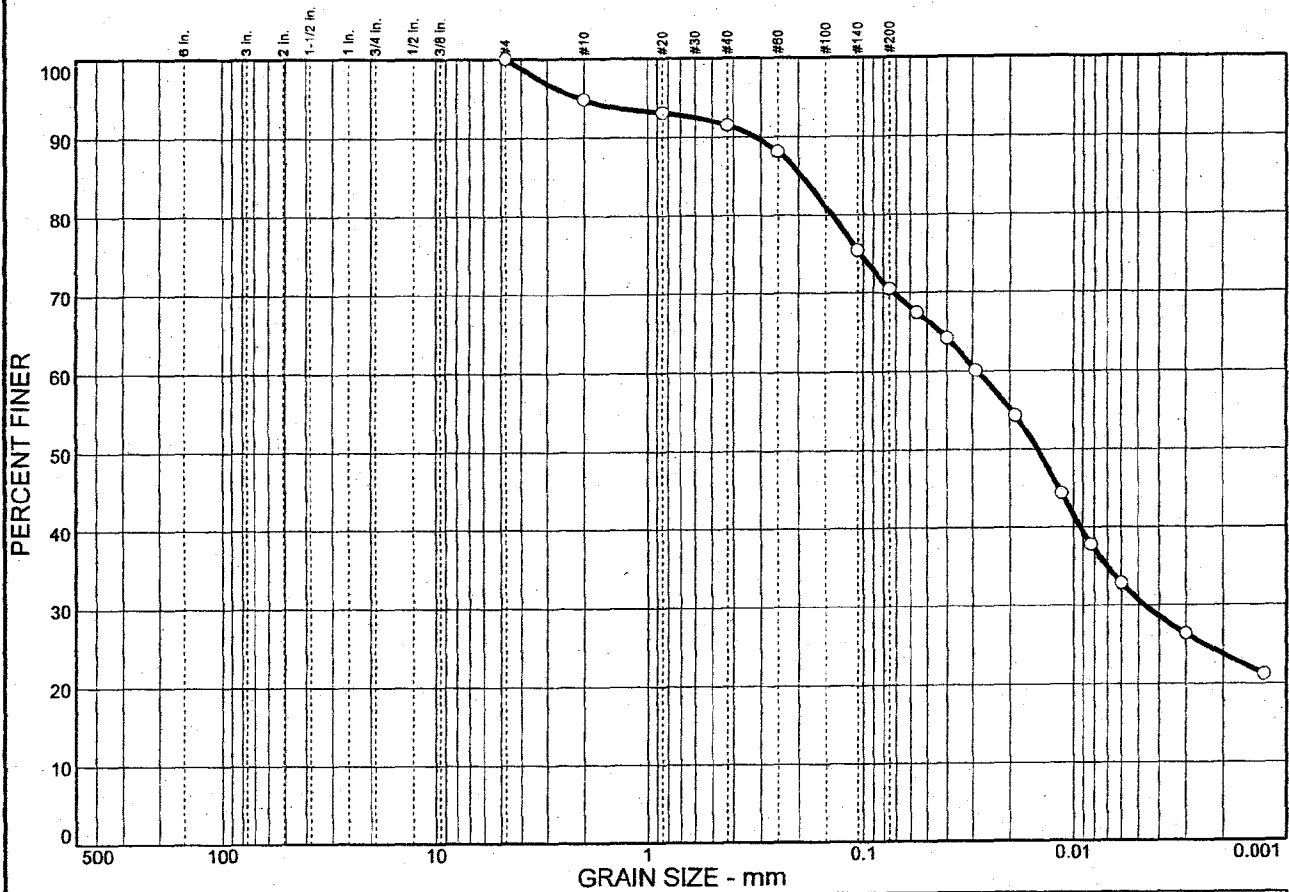

% COBBLES	% GRAVEL	% SAND	% SILT	% CLAY
0.0	0.0	29.5	39.8	30.7

SIEVE SIZE	PERCENT FINER	SPEC.* PERCENT	PASS? (X=NO)
#4	100.0		
#10	94.8		
#20	93.1		
#40	91.5		
#60	88.1		
#140	75.5		
#200	70.5		

**Material Description**

Lean clay with sand

**Atterberg Limits**

PL= 21      LL= 31      PI= 10

**Coefficients**

D<sub>85</sub>= 0.194      D<sub>60</sub>= 0.0287      D<sub>50</sub>= 0.0149  
D<sub>30</sub>= 0.0046      D<sub>15</sub>=              D<sub>10</sub>=  
C<sub>u</sub>=                      C<sub>c</sub>=

**Classification**

USCS= CL                      AASHTO=

**Remarks**

\* (no specification provided)

Sample No.:  
Location: K-7

Source of Sample:

Date: 1-20-06  
Elev./Depth: 10'-15'

<p style="text-align: center;"><b>MACTEC, INC.</b></p> <p style="text-align: center;"><b>Charlotte, North Carolina</b></p>	<p>Client: TVA Project: TVA Kingston - Gypsum Disposal Project No: 3043-05-1064</p>
<p>Figure</p>	



Elapsed time, min	Temp, deg C	Actual reading	Corrected reading	K	Rm	Eff. depth	Diameter mm	Percent finer
0.50	22.5	45.0	40.9	0.0133	46.0	8.8	0.0555	67.5
1.00	22.5	43.0	38.9	0.0133	44.0	9.1	0.0400	64.2
2.00	22.5	40.5	36.4	0.0133	41.5	9.5	0.0289	60.1
5.00	22.5	37.0	32.9	0.0133	38.0	10.1	0.0188	54.3
15.00	22.5	31.0	26.9	0.0133	32.0	11.0	0.0114	44.4
30.00	22.5	27.0	22.9	0.0133	28.0	11.7	0.0083	37.8
60.00	22.6	24.0	19.9	0.0133	25.0	12.2	0.0060	32.8
250.00	22.9	20.0	16.0	0.0132	21.0	12.9	0.0030	26.4
1440.00	22.5	17.0	12.9	0.0133	18.0	13.3	0.0013	21.2

**Fractional Components**

Gravel/Sand based on #4

Sand/Fines based on #200

% COBBLES =

% GRAVEL =

% SAND = 29.5

% SILT = 39.8

% CLAY = 30.7

D85= 0.19    D60= 0.03    D50= 0.01

D30= 0.00



---

**GRAIN SIZE DISTRIBUTION TEST DATA**

---

Client: TVA  
Project: TVA Kingston - Gypsum Disposal  
Project Number: 3043-05-1064

---

**Sample Data**

---

Source:  
Sample No.:  
Elev. or Depth: 10'-15'                      Sample Length(in./cm.):  
Location: K-8  
Description: Sandy fat clay  
Date: 1-20-06                      PL: 27                      LL: 51                      PI: 24  
USCS Classification: CH                      AASHTO Classification:  
Testing Remarks:

---

**Mechanical Analysis Data**

---

Initial

Dry sample and tare= 355.84  
Tare = 0.00  
Dry sample weight = 355.84  
Sample split on number 10 sieve  
Split sample data:  
Sample and tare = 52.23 Tare = .00 Sample weight = 52.23  
Cumulative weight retained tare= .00  
Tare for cumulative weight retained= .00

Sieve	Cumul. Wt. retained	Percent finer
75 inch	0.00	100.0
.375 inch	3.89	98.9
# 4	15.79	95.6
# 10	33.07	90.7
# 20	2.51	86.3
# 40	5.21	81.7
# 60	10.42	72.6
# 140	19.39	57.0
# 200	21.70	53.0

---

**Hydrometer Analysis Data**

---

Separation sieve is #10  
Percent -#10 based upon complete sample= 90.7  
Weight of hydrometer sample: 52.87  
Hygroscopic moisture correction:  
Moist weight & tare = 38.47  
Dry weight & tare = 38.13  
Tare = 10.71  
Hygroscopic moisture= 1.2 %  
Calculated biased weight= 57.58  
Table of composite correction values:  
Temp, deg C: 10.7 23.1 40.2  
Comp. corr: -7.0 -4.0 0.0  
  
Meniscus correction only= 1  
Specific gravity of solids= 2.666  
Specific gravity correction factor= 0.996

---

Hydrometer type: 152H

Effective depth  $L = 16.294964 - 0.164 \times R_m$

Elapsed time, min	Temp, deg C	Actual reading	Corrected reading	K	R <sub>m</sub>	Eff. depth	Diameter mm	Percent finer
0.50	22.5	34.0	29.9	0.0132	35.0	10.6	0.0605	51.6
1.00	22.5	33.0	28.9	0.0132	34.0	10.7	0.0431	49.9
2.00	22.5	32.0	27.9	0.0132	33.0	10.9	0.0307	48.2
5.00	22.5	30.5	26.4	0.0132	31.5	11.1	0.0196	45.6
15.00	22.5	29.0	24.9	0.0132	30.0	11.4	0.0115	43.0
30.00	22.5	28.0	23.9	0.0132	29.0	11.5	0.0082	41.3
60.00	22.6	27.0	22.9	0.0132	28.0	11.7	0.0058	39.6
250.00	23.5	25.0	21.1	0.0130	26.0	12.0	0.0029	36.5
1440.00	22.8	23.0	18.9	0.0131	24.0	12.4	0.0012	32.7

**Fractional Components**

Gravel/Sand based on #4

Sand/Fines based on #200

% COBBLES =            % GRAVEL = 4.4            % SAND = 42.6

% SILT = 14.1            % CLAY = 38.9

D<sub>85</sub> = 0.63    D<sub>60</sub> = 0.13    D<sub>50</sub> = 0.04





GRAIN SIZE DISTRIBUTION TEST DATA

Client: TVA  
Project: TVA Kingston - Gypsum Disposal  
Project Number: 3043-05-1064

Sample Data

Source:  
Sample No.:  
Elev. or Depth: 12'-14'                      Sample Length(in./cm.):  
Location: K-9  
Description: Fat clay with sand  
Date: 1-20-06                      PL: 28                      LL: 50                      PI: 22  
USCS Classification: CH                      AASHTO Classification:  
Testing Remarks:

Mechanical Analysis Data

Initial  
Dry sample and tare= 419.97  
Tare = 0.00  
Dry sample weight = 419.97  
Sample split on number 10 sieve  
Split sample data:  
Sample and tare = 61.91 Tare = .00 Sample weight = 61.91  
Cumulative weight retained tare= .00  
Tare for cumulative weight retained= .00  
Sieve                      Cumul. Wt.                      Percent  
   retained                      finer  
# 10                      0.00                      100.0  
# 20                      0.08                      99.9  
# 40                      0.21                      99.7  
# 60                      0.65                      99.0  
# 140                      10.11                      83.7  
# 200                      14.95                      75.9

Hydrometer Analysis Data

Separation sieve is #10  
Percent -#10 based upon complete sample= 100.0  
Weight of hydrometer sample: 63.07  
Hygroscopic moisture correction:  
Moist weight & tare = 39.12  
Dry weight & tare = 38.60  
Tare = 10.80  
Hygroscopic moisture= 1.9 %  
Calculated biased weight= 61.91  
Table of composite correction values:  
Temp, deg C: 10.7 23.1 40.2  
Comp. corr: -7.0 -4.0 0.0  
Meniscus correction only= 1  
Specific gravity of solids= 2.706  
Specific gravity correction factor= 0.988  
Hydrometer type: 152H  
Effective depth L= 16.294964 - 0.164 x Rm

Elapsed time, min	Temp, deg C	Actual reading	Corrected reading	K	Rm	Eff. depth	Diameter mm	Percent finer
0.50	22.6	48.5	44.4	0.0130	49.5	8.2	0.0526	70.8
1.00	22.6	45.0	40.9	0.0130	46.0	8.8	0.0385	65.2
2.00	22.6	41.0	36.9	0.0130	42.0	9.4	0.0282	58.9
5.00	22.6	38.0	33.9	0.0130	39.0	9.9	0.0183	54.1
15.00	22.6	35.0	30.9	0.0130	36.0	10.4	0.0108	49.3
30.00	22.6	33.0	28.9	0.0130	34.0	10.7	0.0078	46.1
60.00	22.6	31.0	26.9	0.0130	32.0	11.0	0.0056	42.9
250.00	22.6	27.0	22.9	0.0130	28.0	11.7	0.0028	36.5
1440.00	21.9	24.0	19.7	0.0131	25.0	12.2	0.0012	31.5

**Fractional Components**

Gravel/Sand based on #4

Sand/Fines based on #200

% COBBLES =                    % GRAVEL =

% SAND = 24.1

% SILT = 34.1                % CLAY = 41.8

D85= 0.11    D60= 0.03    D50= 0.01



---

**GRAIN SIZE DISTRIBUTION TEST DATA**

---

Client: TVA  
Project: TVA Kingston - Gypsum Disposal  
Project Number: 3043-05-1064

---

**Sample Data**

---

Source:  
Sample No.:  
Elev. or Depth: 12'-14'                      Sample Length(in./cm.):  
Location: K-10  
Description: Sandy lean clay  
Date: 1-20-06              PL: 26                      LL: 47                      PI: 21  
USCS Classification: CL                      AASHTO Classification:  
Testing Remarks:

---

**Mechanical Analysis Data**

---

Initial

Dry sample and tare= 496.31  
Tare = 0.00  
Dry sample weight = 496.31  
Sample split on number 10 sieve  
Split sample data:  
Sample and tare = 56.85 Tare = .00 Sample weight = 56.85  
Cumulative weight retained tare= .00  
Tare for cumulative weight retained= .00

Sieve	Cumul. Wt. retained	Percent finer
# 10	0.00	100.0
# 20	0.01	100.0
# 40	0.03	99.9
# 60	0.37	99.3
# 140	16.37	71.2
# 200	21.19	62.7

---

**Hydrometer Analysis Data**

---

Separation sieve is #10  
Percent -#10 based upon complete sample= 100.0  
Weight of hydrometer sample: 58.15  
Hygroscopic moisture correction:  
Moist weight & tare = 47.46  
Dry weight & tare = 46.65  
Tare = 11.18  
Hygroscopic moisture= 2.3 %  
Calculated biased weight= 56.85  
Table of composite correction values:  
Temp, deg C: 10.7 23.1 40.2  
Comp. corr: -7.0 -4.0 0.0

---

Meniscus correction only= 1  
Specific gravity of solids= 2.664  
Specific gravity correction factor= 0.997  
Hydrometer type: 152H  
Effective depth L= 16.294964 - 0.164 x Rm

---

Elapsed time, min	Temp, deg C	Actual reading	Corrected reading	K	Rm	Eff. depth	Diameter mm	Percent finer
0.50	22.6	37.5	33.4	0.0132	38.5	10.0	0.0588	58.5
1.00	22.6	35.0	30.9	0.0132	36.0	10.4	0.0424	54.2
2.00	22.6	32.5	28.4	0.0132	33.5	10.8	0.0306	49.8
5.00	22.6	30.0	25.9	0.0132	31.0	11.2	0.0197	45.4
15.00	22.6	28.0	23.9	0.0132	29.0	11.5	0.0115	41.9
30.00	22.6	27.0	22.9	0.0132	28.0	11.7	0.0082	40.1
60.00	22.6	26.0	21.9	0.0132	27.0	11.9	0.0059	38.4
250.00	22.6	24.0	19.9	0.0132	25.0	12.2	0.0029	34.9
1440.00	21.9	22.0	17.7	0.0133	23.0	12.5	0.0012	31.1

**Fractional Components**

Gravel/Sand based on #4

Sand/Fines based on #200

% COBBLES =                      % GRAVEL =

% SAND = 37.3

% SILT = 25.1                      % CLAY = 37.6

D<sub>85</sub>= 0.16    D<sub>60</sub>= 0.06    D<sub>50</sub>= 0.03







Elapsed time, min	Temp, deg C	Actual reading	Corrected reading	K	Rm	Eff. depth	Diameter mm	Percent finer
0.50	22.5	18.0	13.9	0.0130	19.0	13.2	0.0667	24.8
1.00	22.5	17.0	12.9	0.0130	18.0	13.3	0.0475	23.0
2.00	22.5	16.0	11.9	0.0130	17.0	13.5	0.0338	21.2
5.00	22.5	15.0	10.9	0.0130	16.0	13.7	0.0215	19.4
15.00	22.5	14.0	9.9	0.0130	15.0	13.8	0.0125	17.6
30.00	22.5	13.5	9.4	0.0130	14.5	13.9	0.0089	16.7
60.00	22.5	13.0	8.9	0.0130	14.0	14.0	0.0063	15.8
250.00	22.7	12.5	8.4	0.0130	13.5	14.1	0.0031	15.0
1440.00	22.2	12.0	7.8	0.0130	13.0	14.2	0.0013	13.9

---

**Fractional Components**

---

Gravel/Sand based on #4

Sand/Fines based on #200

% COBBLES =                    % GRAVEL =                    % SAND = 74.3  
 % SILT = 10.3                    % CLAY = 15.4

D85= 0.35    D60= 0.20    D50= 0.17  
 D30= 0.11    D15= 0.00



GRAIN SIZE DISTRIBUTION TEST DATA

Client: TVA  
Project: TVA Kingston - Gypsum Disposal  
Project Number: 3043-05-1064

Sample Data

Source:  
Sample No.:  
Elev. or Depth: 12'-14' Sample Length(in./cm.):  
Location: K-12  
Description: Sandy lean clay  
Date: 1-20-06 PL: 26 LL: 48 PI: 22  
USCS Classification: CL AASHTO Classification:  
Testing Remarks:

Mechanical Analysis Data

Initial  
Dry sample and tare= 438.64  
Tare = 0.00  
Dry sample weight = 438.64  
Sample split on number 10 sieve  
Split sample data:  
Sample and tare = 58.67 Tare = .00 Sample weight = 58.67  
Cumulative weight retained tare= .00  
Tare for cumulative weight retained= .00  
Sieve Cumul. Wt. Percent  
retained finer  
# 10 0.00 100.0  
# 20 0.04 99.9  
# 40 0.07 99.9  
# 60 2.24 96.2  
# 140 18.57 68.3  
# 200 21.26 63.8

Hydrometer Analysis Data

Separation sieve is #10  
Percent -#10 based upon complete sample= 100.0  
Weight of hydrometer sample: 59.59  
Hygroscopic moisture correction:  
Moist weight & tare = 47.14  
Dry weight & tare = 46.58  
Tare = 11.00  
Hygroscopic moisture= 1.6 %  
Calculated biased weight= 58.67  
Table of composite correction values:  
Temp, deg C: 10.7 23.1 40.2  
Comp. corr: -7.0 -4.0 0.0

Meniscus correction only= 1  
Specific gravity of solids= 2.708  
Specific gravity correction factor= 0.987  
Hydrometer type: 152H  
Effective depth L= 16.294964 - 0.164 x Rm

Elapsed time, min	Temp, deg C	Actual reading	Corrected reading	K	Rm	Eff. depth	Diameter mm	Percent finer
0.50	22.6	38.5	34.4	0.0130	39.5	9.8	0.0576	57.8
1.00	22.6	33.0	28.9	0.0130	34.0	10.7	0.0425	48.6
2.00	22.6	30.0	25.9	0.0130	31.0	11.2	0.0308	43.5
5.00	22.6	27.0	22.9	0.0130	28.0	11.7	0.0199	38.5
15.00	22.6	25.0	20.9	0.0130	26.0	12.0	0.0116	35.1
30.00	22.6	24.0	19.9	0.0130	25.0	12.2	0.0083	33.4
60.00	22.6	23.0	18.9	0.0130	24.0	12.4	0.0059	31.8
250.00	22.6	20.0	15.9	0.0130	21.0	12.9	0.0029	26.7
1440.00	21.9	17.0	12.7	0.0131	18.0	13.3	0.0013	21.4

### Fractional Components

Gravel/Sand based on #4

Sand/Fines based on #200

% COBBLES =                    % GRAVEL =

% SAND = 36.2

% SILT = 33.0                % CLAY = 30.8

D<sub>85</sub> = 0.19    D<sub>60</sub> = 0.06    D<sub>50</sub> = 0.04

D<sub>30</sub> = 0.00

# Particle Size Distribution Report

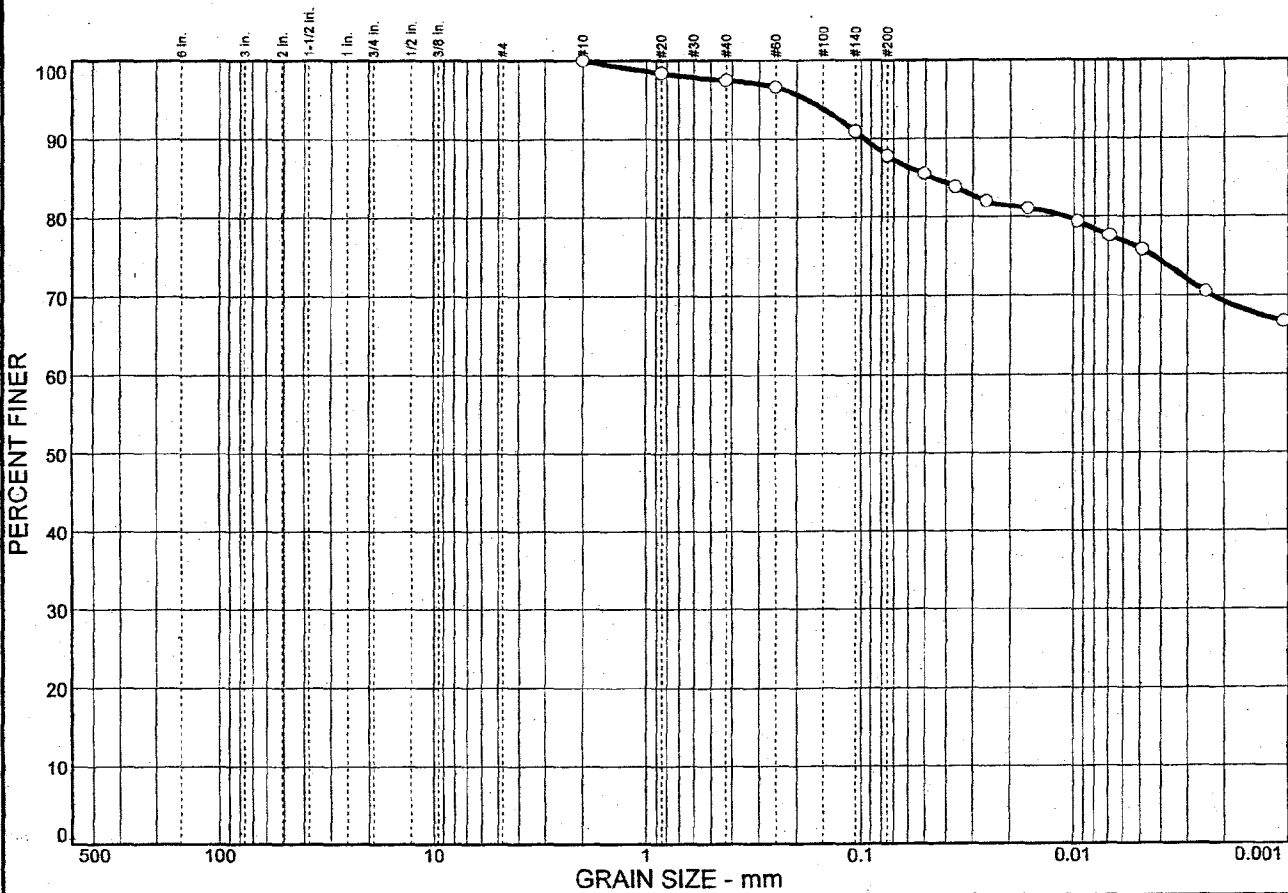

% COBBLES	% GRAVEL	% SAND	% SILT	% CLAY
0.0	0.0	12.2	11.9	75.9

SIEVE SIZE	PERCENT FINER	SPEC.* PERCENT	PASS? (X=NO)
#10	100.0		
#20	98.4		
#40	97.5		
#60	96.6		
#140	90.9		
#200	87.8		

**Material Description**  
Elastic silt

**Atterberg Limits**  
PL= 37      LL= 69      PI= 32

**Coefficients**  
D<sub>85</sub>= 0.0457      D<sub>60</sub>=      D<sub>50</sub>=  
D<sub>30</sub>=      D<sub>15</sub>=      D<sub>10</sub>=  
C<sub>u</sub>=      C<sub>c</sub>=

**Classification**  
USCS= MH      AASHTO=

**Remarks**

\* (no specification provided)

Sample No.:  
Location: K-13

Source of Sample:

Date: 1-20-06  
Elev./Depth: 12'-14'

<b>MACTEC, INC.</b> Charlotte, North Carolina	Client: TVA
	Project: TVA Kingston - Gypsum Disposal
Project No: 3043-05-1064	Figure



Elapsed time, min	Temp, deg C	Actual reading	Corrected reading	K	Rm	Eff. depth	Diameter mm	Percent finer
0.50	22.6	52.5	48.4	0.0131	53.5	7.5	0.0507	85.5
1.00	22.6	51.5	47.4	0.0131	52.5	7.7	0.0362	83.8
2.00	22.6	50.5	46.4	0.0131	51.5	7.8	0.0259	82.0
5.00	22.6	50.0	45.9	0.0131	51.0	7.9	0.0165	81.1
15.00	22.6	49.0	44.9	0.0131	50.0	8.1	0.0096	79.4
30.00	22.6	48.0	43.9	0.0131	49.0	8.3	0.0069	77.6
60.00	22.6	47.0	42.9	0.0131	48.0	8.4	0.0049	75.8
250.00	22.6	44.0	39.9	0.0131	45.0	8.9	0.0025	70.5
1440.00	22.0	42.0	37.7	0.0132	43.0	9.2	0.0011	66.7

**Fractional Components**

Gravel/Sand based on #4

Sand/Fines based on #200

% COBBLES =

% GRAVEL =

% SAND = 12.2

% SILT = 11.9

% CLAY = 75.9

D<sub>85</sub> = 0.05





---

**GRAIN SIZE DISTRIBUTION TEST DATA**

---

Client: TVA  
Project: TVA Kingston - Gypsum Disposal  
Project Number: 3043-05-1064

---

**Sample Data**

---

Source:  
Sample No.:  
Elev. or Depth: 12'-14'                                  Sample Length (in./cm.):  
Location: K-14  
Description: Elastic silt  
Date: 1-20-06                  PL: 41                                  LL: 65                                  PI: 24  
USCS Classification: MH                                  AASHTO Classification:  
Testing Remarks:

---

**Mechanical Analysis Data**

---

Initial

Dry sample and tare= 411.09  
Tare = 0.00  
Dry sample weight = 411.09  
Sample split on number 10 sieve  
Split sample data:  
Sample and tare = 56.30 Tare = .00 Sample weight = 56.30  
Cumulative weight retained tare= .00  
Tare for cumulative weight retained= .00

Sieve	Cumul. Wt. retained	Percent finer
# 10	0.00	100.0
# 20	0.03	99.9
# 40	0.10	99.8
# 60	0.27	99.5
# 140	1.46	97.4
# 200	2.75	95.1

---

**Hydrometer Analysis Data**

---

Separation sieve is #10  
Percent -#10 based upon complete sample= 100.0  
Weight of hydrometer sample: 58.24  
Hygroscopic moisture correction:  
Moist weight & tare = 52.43  
Dry weight & tare = 51.07  
Tare = 11.53  
Hygroscopic moisture= 3.4 %  
Calculated biased weight= 56.30  
Table of composite correction values:  
Temp, deg C: 10.7 23.1 40.2  
Comp. corr: -7.0 -4.0 0.0

Meniscus correction only= 1  
Specific gravity of solids= 2.733  
Specific gravity correction factor= 0.982  
Hydrometer type: 152H  
Effective depth L= 16.294964 - 0.164 x Rm

---

Elapsed time, min	Temp, deg C	Actual reading	Corrected reading	K	Rm	Eff. depth	Diameter mm	Percent finer
0.50	22.6	56.0	51.9	0.0129	57.0	6.9	0.0481	90.5
1.00	22.6	53.0	48.9	0.0129	54.0	7.4	0.0352	85.3
2.00	22.6	51.0	46.9	0.0129	52.0	7.8	0.0254	81.8
5.00	22.6	48.5	44.4	0.0129	49.5	8.2	0.0165	77.4
15.00	22.6	44.5	40.4	0.0129	45.5	8.8	0.0099	70.4
30.00	22.6	42.0	37.9	0.0129	43.0	9.2	0.0072	66.1
60.00	22.6	39.0	34.9	0.0129	40.0	9.7	0.0052	60.8
250.00	22.6	34.0	29.9	0.0129	35.0	10.6	0.0027	52.1
1440.00	22.4	30.0	25.8	0.0129	31.0	11.2	0.0011	45.1

### Fractional Components

Gravel/Sand based on #4

Sand/Fines based on #200

% COBBLES =

% GRAVEL =

% SAND = 4.9

% SILT = 34.9

% CLAY = 60.2

D85= 0.03 D60= 0.00 D50= 0.00

# Particle Size Distribution Report

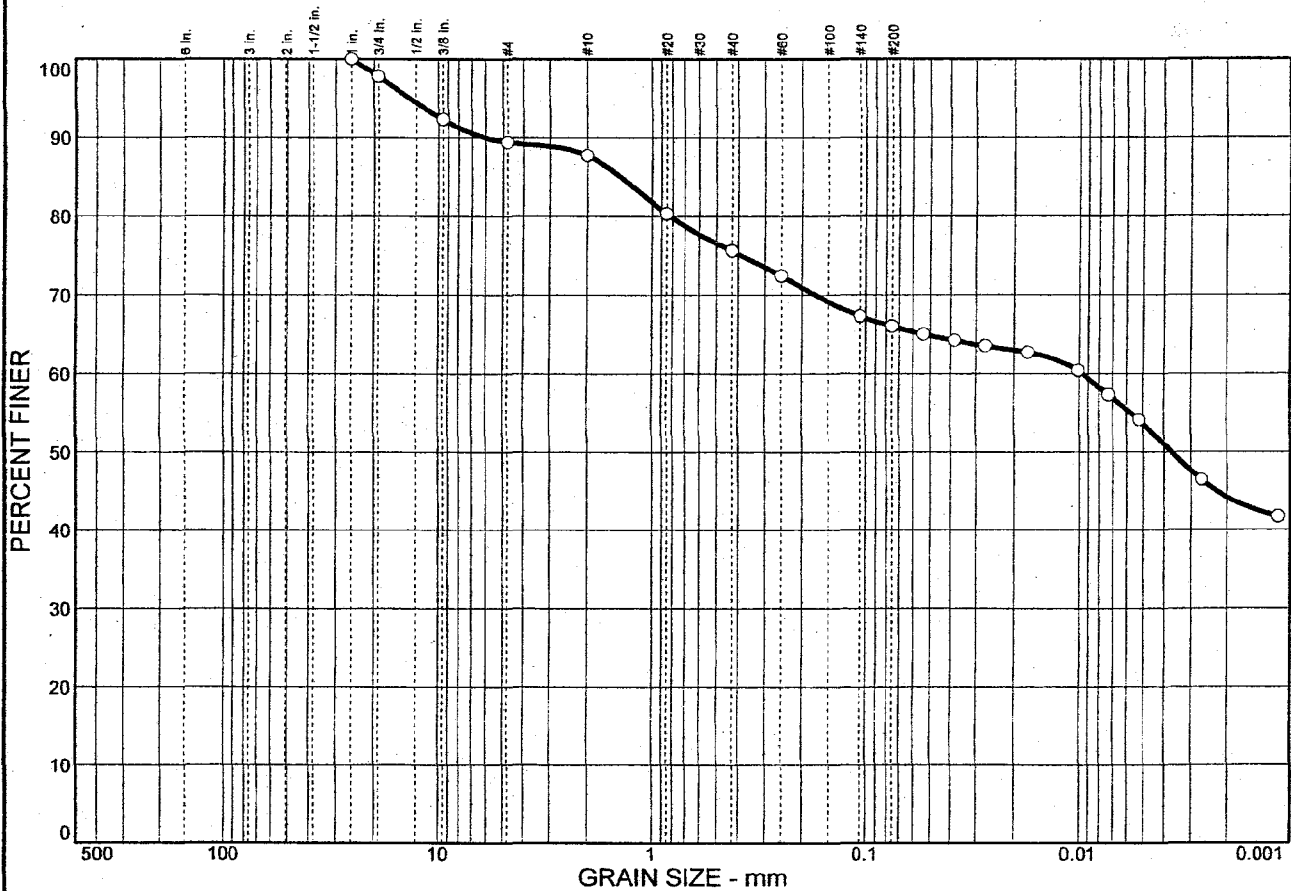

% COBBLES	% GRAVEL	% SAND	% SILT	% CLAY
0.0	10.6	23.4	12.4	53.6

SIEVE SIZE	PERCENT FINER	SPEC.* PERCENT	PASS? (X=NO)
1 in.	100.0		
.75 in.	97.8		
.375 in.	92.3		
#4	89.4		
#10	87.7		
#20	80.3		
#40	75.6		
#60	72.4		
#140	67.3		
#200	66.0		

**Material Description**

Sandy elastic silt

**Atterberg Limits**

PL= 42      LL= 60      PI= 18

**Coefficients**

D<sub>85</sub>= 1.40      D<sub>60</sub>= 0.0096      D<sub>50</sub>= 0.0037  
D<sub>30</sub>=              D<sub>15</sub>=              D<sub>10</sub>=  
C<sub>u</sub>=              C<sub>c</sub>=

**Classification**

USCS= MH      AASHTO=

**Remarks**

\* (no specification provided)

Sample No.:      Source of Sample:      Date: 1-20-06  
Location: K-15A      Elev./Depth: 12'-13'

<p style="text-align: center;"><b>MACTEC, INC.</b></p> <p style="text-align: center;">Charlotte, North Carolina</p>	<p>Client: TVA  Project: TVA Kingston - Gypsum Disposal  Project No: 3043-05-1064</p>
---	---

Figure

---

**GRAIN SIZE DISTRIBUTION TEST DATA**

---

Client: TVA  
Project: TVA Kingston - Gypsum Disposal  
Project Number: 3043-05-1064

---

**Sample Data**

---

Source:  
Sample No.:  
Elev. or Depth: 12'-13'                      Sample Length(in./cm.):  
Location: K-15A  
Description: Sandy elastic silt  
Date: 1-20-06                      PL: 42                      LL: 60                      PI: 18  
USCS Classification: MH                      AASHTO Classification:  
Testing Remarks:

---

**Mechanical Analysis Data**

---

Initial

Dry sample and tare= 397.13  
Tare = 0.00  
Dry sample weight = 397.13  
Sample split on number 10 sieve  
Split sample data:  
Sample and tare = 55.76 Tare = .00 Sample weight = 55.76  
Cumulative weight retained tare= .00  
Tare for cumulative weight retained= .00

Sieve	Cumul. Wt. retained	Percent finer
1 inch	0.00	100.0
.75 inch	8.62	97.8
.375 inch	30.57	92.3
# 4	41.99	89.4
# 10	49.01	87.7
# 20	4.69	80.3
# 40	7.71	75.6
# 60	9.71	72.4
# 140	12.97	67.3
# 200	13.82	66.0

---

**Hydrometer Analysis Data**

---

Separation sieve is #10  
Percent -#10 based upon complete sample= 87.7  
Weight of hydrometer sample: 59.02  
Hygroscopic moisture correction:  
Moist weight & tare = 51.43  
Dry weight & tare = 49.23  
Tare = 11.65  
Hygroscopic moisture= 5.9 %  
Calculated biased weight= 63.58  
Table of composite correction values:  
Temp, deg C: 10.7 23.1 40.2  
Temp. corr: -7.0 -4.0 0.0  
Meniscus correction only= 1  
Specific gravity of solids= 2.711

---

Specific gravity correction factor= 0.987

Hydrometer type: 152H

Effective depth  $L = 16.294964 - 0.164 \times R_m$

Elapsed time, min	Temp, deg C	Actual reading	Corrected reading	K	R <sub>m</sub>	Eff. depth	Diameter mm	Percent finer
0.50	22.6	46.0	41.9	0.0130	47.0	8.6	0.0538	65.0
1.00	22.6	45.5	41.4	0.0130	46.5	8.7	0.0382	64.2
2.00	22.6	45.0	40.9	0.0130	46.0	8.8	0.0272	63.5
5.00	22.6	44.5	40.4	0.0130	45.5	8.8	0.0173	62.7
15.00	22.6	43.0	38.9	0.0130	44.0	9.1	0.0101	60.4
30.00	22.6	41.0	36.9	0.0130	42.0	9.4	0.0073	57.3
60.00	22.6	39.0	34.9	0.0130	40.0	9.7	0.0052	54.1
250.00	22.6	34.0	29.9	0.0130	35.0	10.6	0.0027	46.4
1440.00	22.6	31.0	26.9	0.0130	32.0	11.0	0.0011	41.7

#### Fractional Components

Gravel/Sand based on #4

Sand/Fines based on #200

% COBBLES =                    % GRAVEL = 10.6                    % SAND = 23.4

% SILT = 12.4                    % CLAY = 53.6

D<sub>85</sub>= 1.40    D<sub>60</sub>= 0.01    D<sub>50</sub>= 0.00

# Particle Size Distribution Report

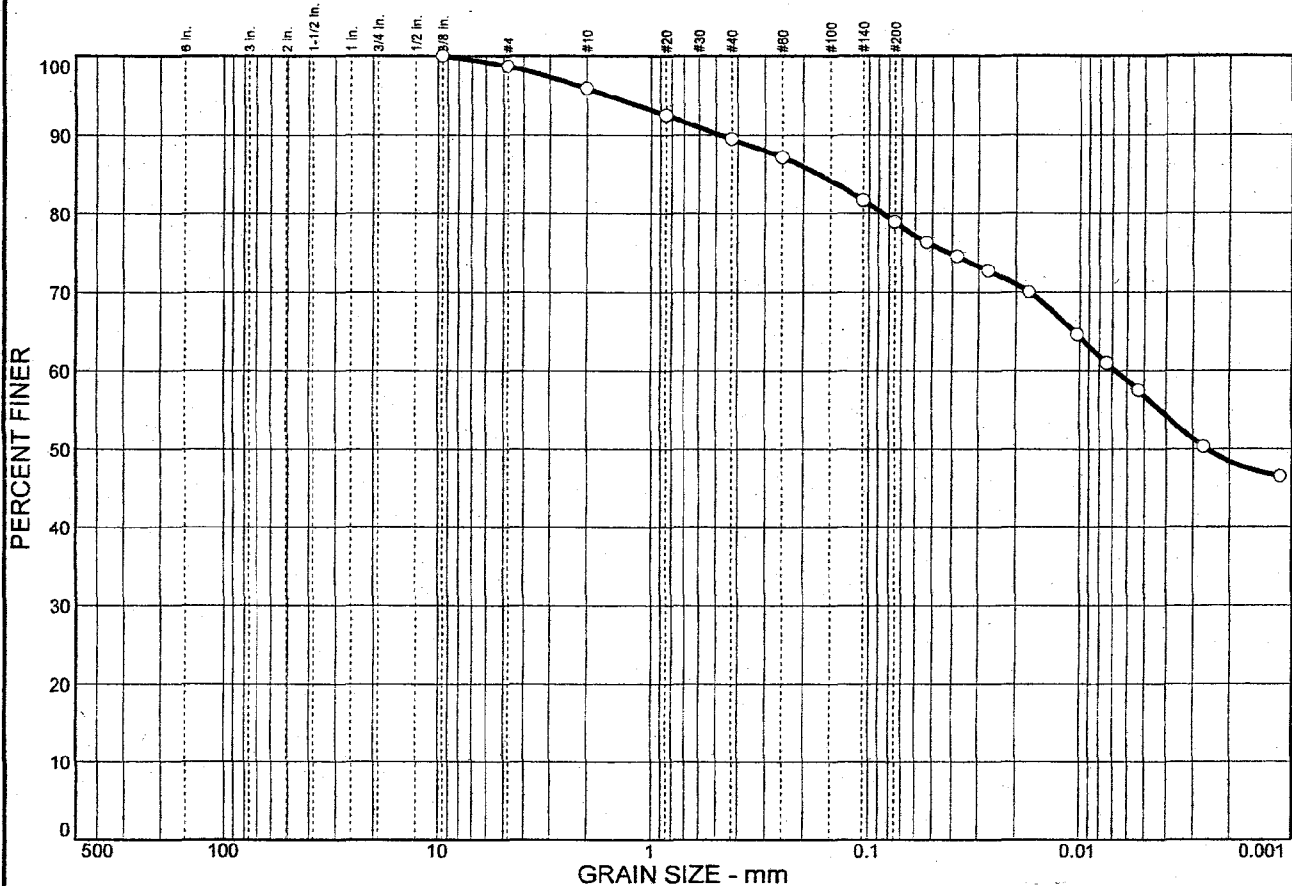

% COBBLES	% GRAVEL	% SAND	% SILT	% CLAY
0.0	1.3	19.8	22.0	56.9

SIEVE SIZE	PERCENT FINER	SPEC.* PERCENT	PASS? (X=NO)
.375 in.	100.0		
#4	98.7		
#10	95.9		
#20	92.5		
#40	89.5		
#60	87.2		
#140	81.7		
#200	78.9		

**Material Description**  
Elastic silt with sand

**Atterberg Limits**  
PL= 29      LL= 52      PI= 23

**Coefficients**  
D<sub>85</sub>= 0.169      D<sub>60</sub>= 0.0067      D<sub>50</sub>= 0.0026  
D<sub>30</sub>=              D<sub>15</sub>=              D<sub>10</sub>=  
C<sub>u</sub>=                C<sub>c</sub>=

**Classification**  
USCS= MH      AASHTO=

**Remarks**

\* (no specification provided)

Sample No.:  
Location: K-16

Source of Sample:

Date: 1-20-06  
Elev./Depth: 10'-15'

<p style="text-align: center; font-weight: bold; font-size: 1.2em;">MACTEC, INC.</p> <p style="text-align: center; font-weight: bold;">Charlotte, North Carolina</p>	<p>Client: TVA Project: TVA Kingston - Gypsum Disposal Project No: 3043-05-1064</p> <p style="text-align: right;">Figure</p>
--	--

GRAIN SIZE DISTRIBUTION TEST DATA

Client: TVA  
Project: TVA Kingston - Gypsum Disposal  
Project Number: 3043-05-1064

Sample Data

Source:  
Sample No.:  
Elev. or Depth: 10'-15' Sample Length(in./cm.):  
Location: K-16  
Description: Elastic silt with sand  
Date: 1-20-06 PL: 29 LL: 52 PI: 23  
USCS Classification: MH AASHTO Classification:  
Testing Remarks:

Mechanical Analysis Data

Initial  
Dry sample and tare= 265.46  
Tare = 0.00  
Dry sample weight = 265.46  
Sample split on number 10 sieve  
Split sample data:  
Sample and tare = 52.09 Tare = .00 Sample weight = 52.09  
Cumulative weight retained tare= .00  
Tare for cumulative weight retained= .00

Sieve	Cumul. Wt. retained	Percent finer
.375 inch	0.00	100.0
# 4	3.36	98.7
# 10	10.82	95.9
# 20	1.86	92.5
# 40	3.45	89.5
# 60	4.74	87.2
# 140	7.73	81.7
# 200	9.25	78.9

Hydrometer Analysis Data

Separation sieve is #10  
Percent -#10 based upon complete sample= 95.9  
Weight of hydrometer sample: 52.72  
Hygroscopic moisture correction:  
Moist weight & tare = 46.63  
Dry weight & tare = 46.20  
Tare = 10.91  
Hygroscopic moisture= 1.2 %  
Calculated biased weight= 54.31  
Table of composite correction values:  
Temp, deg C: 10.7 23.1 40.2  
Comp. corr: -7.0 -4.0 0.0

Manniscus correction only= 1  
Specific gravity of solids= 2.748  
Specific gravity correction factor= 0.979  
Hydrometer type: 152H

Effective depth  $L = 16.294964 - 0.164 \times R_m$

Elapsed time, min	Temp, deg C	Actual reading	Corrected reading	K	Rm	Eff. depth	Diameter mm	Percent finer
0.50	22.5	46.5	42.4	0.0129	47.5	8.5	0.0530	76.3
1.00	22.5	45.5	41.4	0.0129	46.5	8.7	0.0379	74.5
2.00	22.5	44.5	40.4	0.0129	45.5	8.8	0.0270	72.7
5.00	22.5	43.0	38.9	0.0129	44.0	9.1	0.0173	70.0
15.00	22.5	40.0	35.9	0.0129	41.0	9.6	0.0103	64.6
30.00	22.5	38.0	33.9	0.0129	39.0	9.9	0.0074	61.0
60.00	22.6	36.0	31.9	0.0128	37.0	10.2	0.0053	57.5
250.00	22.6	32.0	27.9	0.0128	33.0	10.9	0.0027	50.3
1440.00	22.3	30.0	25.8	0.0129	31.0	11.2	0.0011	46.5

**Fractional Components**

Gravel/Sand based on #4

Sand/Fines based on #200

% COBBLES =            % GRAVEL = 1.3            % SAND = 19.8

% SILT = 22.0            % CLAY = 56.9

D<sub>85</sub> = 0.17    D<sub>60</sub> = 0.01    D<sub>50</sub> = 0.00



# Particle Size Distribution Report

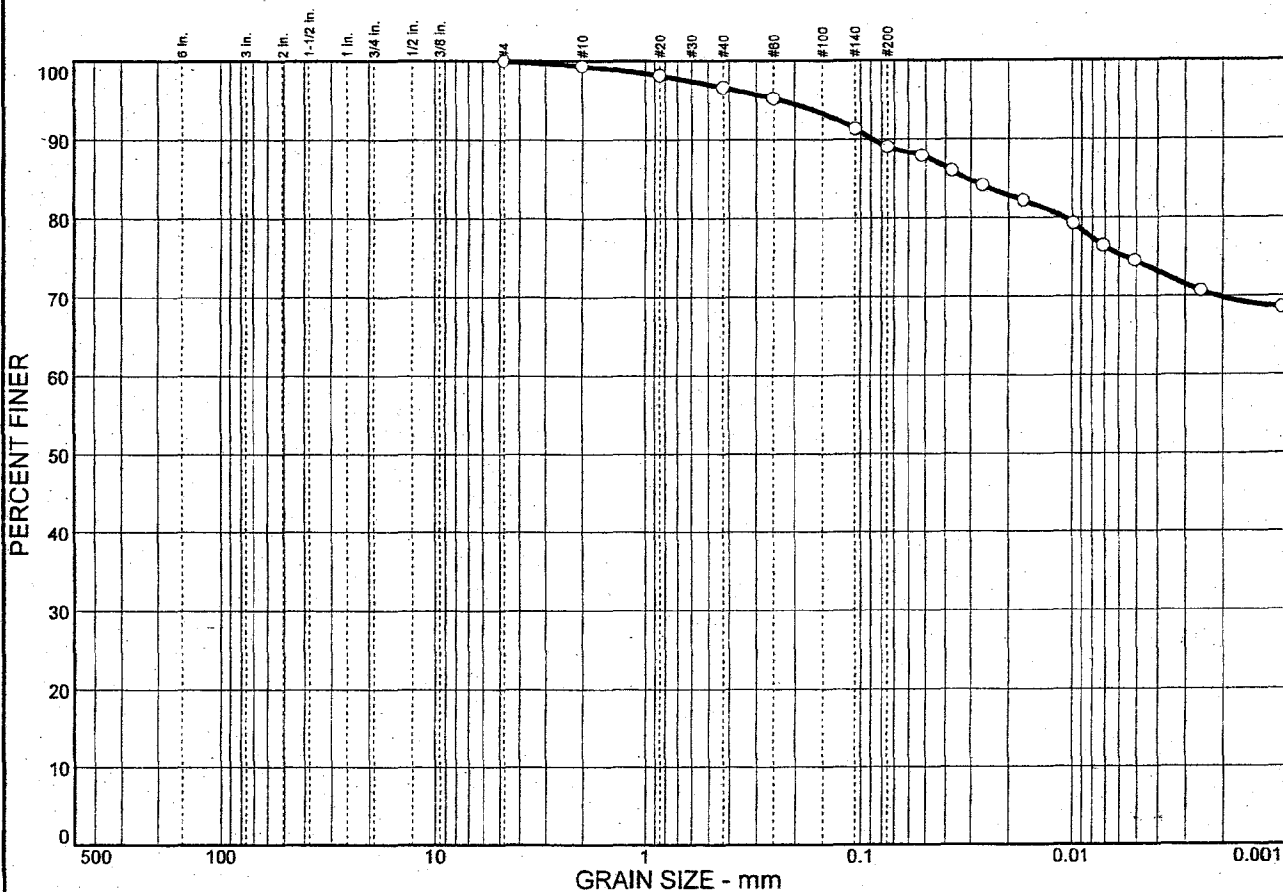

% COBBLES	% GRAVEL	% SAND	% SILT	% CLAY
0.0	0.0	11.0	14.6	74.4

SIEVE SIZE	PERCENT FINER	SPEC.* PERCENT	PASS? (X=NO)
#4	100.0		
#10	99.3		
#20	98.1		
#40	96.6		
#60	95.2		
#140	91.3		
#200	89.0		

**Material Description**

Elastic silt

PL= 40	<b>Atterberg Limits</b>	LL= 75	PI= 35
	<b>Coefficients</b>		
D <sub>85</sub> = 0.0314	D <sub>60</sub> =	D <sub>50</sub> =	
D <sub>30</sub> =	D <sub>15</sub> =	D <sub>10</sub> =	
C <sub>u</sub> =	C <sub>c</sub> =		
<b>Classification</b>			
USCS= MH		AASHTO=	
<b>Remarks</b>			

\* (no specification provided)

Sample No.:  
Location: K-17

Source of Sample:

Date: 1-20-06  
Elev./Depth: 10'-15'

<p style="font-size: 1.2em; font-weight: bold; margin: 0;">MACTEC, INC.</p> <p style="font-size: 1.1em; font-weight: bold; margin: 0;">Charlotte, North Carolina</p>	<p>Client: TVA Project: TVA Kingston - Gypsum Disposal Project No: 3043-05-1064</p> <p style="text-align: right;">Figure</p>
--	--

**GRAIN SIZE DISTRIBUTION TEST DATA**

Client: TVA  
Project: TVA Kingston - Gypsum Disposal  
Project Number: 3043-05-1064

**Sample Data**

Source:  
Sample No.:  
Elev. or Depth: 10'-15'                      Sample Length(in./cm.):  
Location: K-17  
Description: Elastic silt  
Date: 1-20-06                      PL: 40                      LL: 75                      PI: 35  
USCS Classification: MH                      AASHTO Classification:  
Testing Remarks:

**Mechanical Analysis Data**

Initial

Dry sample and tare= 285.36  
Tare = 0.00  
Dry sample weight = 285.36  
Sample split on number 10 sieve  
Split sample data:  
Sample and tare = 51.22 Tare = .00 Sample weight = 51.22  
Cumulative weight retained tare= .00  
Tare for cumulative weight retained= .00

Sieve	Cumul. Wt. retained	Percent finer
# 4	0.00	100.0
# 10	1.90	99.3
# 20	0.64	98.1
# 40	1.37	96.6
# 60	2.10	95.2
# 140	4.12	91.3
# 200	5.29	89.0

**Hydrometer Analysis Data**

Separation sieve is #10  
Percent -#10 based upon complete sample= 99.3  
Weight of hydrometer sample: 52.33  
Hygroscopic moisture correction:  
Moist weight & tare = 47.75  
Dry weight & tare = 46.97  
Tare = 10.89  
Hygroscopic moisture= 2.2 %  
Calculated biased weight= 51.58  
Table of composite correction values:  
Temp, deg C: 10.7 23.1 40.2  
Comp. corr: -7.0 -4.0 0.0

Meniscus correction only= 1  
Specific gravity of solids= 2.699  
Specific gravity correction factor= 0.989  
Hydrometer type: 152H  
Effective depth L= 16.294964 - 0.164 x Rm

Elapsed time, min	Temp, deg C	Actual reading	Corrected reading	K	Rm	Eff. depth	Diameter mm	Percent finer
0.50	22.5	50.0	45.9	0.0130	51.0	7.9	0.0519	87.9
1.00	22.5	49.0	44.9	0.0130	50.0	8.1	0.0371	86.0
2.00	22.5	48.0	43.9	0.0130	49.0	8.3	0.0265	84.1
5.00	22.5	47.0	42.9	0.0130	48.0	8.4	0.0169	82.2
15.00	22.5	45.5	41.4	0.0130	46.5	8.7	0.0099	79.3
30.00	22.5	44.0	39.9	0.0130	45.0	8.9	0.0071	76.4
60.00	22.6	43.0	38.9	0.0130	44.0	9.1	0.0051	74.5
250.00	22.6	41.0	36.9	0.0130	42.0	9.4	0.0025	70.7
1440.00	22.2	40.0	35.8	0.0131	41.0	9.6	0.0011	68.6

---

**Fractional Components**

---

Gravel/Sand based on #4

Sand/Fines based on #200

% COBBLES =

% GRAVEL =

% SAND = 11.0

% SILT = 14.6

% CLAY = 74.4

D<sub>85</sub> = 0.03



GRAIN SIZE DISTRIBUTION TEST DATA

Client: TVA  
Project: TVA Kingston - Gypsum Disposal  
Project Number: 3043-05-1064

Sample Data

Source:  
Sample No.:  
Elev. or Depth: 10'-15' Sample Length(in./cm.):  
Location: K-18  
Description: Elastic silt with sand  
Date: 1-20-06 PL: 37 LL: 71 PI: 34  
USCS Classification: MH AASHTO Classification:  
Testing Remarks:

Mechanical Analysis Data

Initial  
Dry sample and tare= 304.28  
Tare = 0.00  
Dry sample weight = 304.28  
Sample split on number 10 sieve  
Split sample data:  
Sample and tare = 56.68 Tare = .00 Sample weight = 56.68  
Cumulative weight retained tare= .00  
Tare for cumulative weight retained= .00

Sieve	Cumul. Wt. retained	Percent finer
.375 inch	0.00	100.0
# 4	25.63	91.6
# 10	49.03	83.9
# 20	0.14	83.7
# 40	0.43	83.3
# 60	0.92	82.5
# 140	1.87	81.1
# 200	3.06	79.4

Hydrometer Analysis Data

Separation sieve is #10  
Percent -#10 based upon complete sample= 83.9  
Weight of hydrometer sample: 57.16  
Hygroscopic moisture correction:  
Moist weight & tare = 43.17  
Dry weight & tare = 42.90  
Tare = 11.33  
Hygroscopic moisture= 0.9 %  
Calculated biased weight= 67.55  
Table of composite correction values:  
Temp, deg C: 10.7 23.1 40.2  
Comp. corr: -7.0 -4.0 0.0  
Viscosity correction only= 1  
Specific gravity of solids= 2.781  
Specific gravity correction factor= 0.972  
Hydrometer type: 152H

Effective depth L= 16.294964 - 0.164 x Rm

Elapsed time, min	Temp, deg C	Actual reading	Corrected reading	K	Rm	Eff. depth	Diameter mm	Percent finer
0.50	22.5	57.0	52.9	0.0127	58.0	6.8	0.0469	76.1
1.00	22.5	55.5	51.4	0.0127	56.5	7.0	0.0338	73.9
2.00	22.5	54.0	49.9	0.0127	55.0	7.3	0.0243	71.7
5.00	22.5	52.0	47.9	0.0127	53.0	7.6	0.0157	68.9
15.00	22.5	50.0	45.9	0.0127	51.0	7.9	0.0093	66.0
30.00	22.5	49.0	44.9	0.0127	50.0	8.1	0.0066	64.5
60.00	22.6	47.5	43.4	0.0127	48.5	8.3	0.0047	62.4
250.00	22.9	45.0	41.0	0.0127	46.0	8.8	0.0024	58.9
1440.00	22.4	44.0	39.8	0.0128	45.0	8.9	0.0010	57.3

Fractional Components

Gravel/Sand based on #4

Sand/Fines based on #200

% COBBLES =                    % GRAVEL = 8.4                    % SAND = 12.2  
% SILT = 16.7                    % CLAY = 62.7

D85= 2.44    D60= 0.00

**MOISTURE-DENSITY RELATIONSHIP TEST RESULTS**

# COMPACTION TEST REPORT

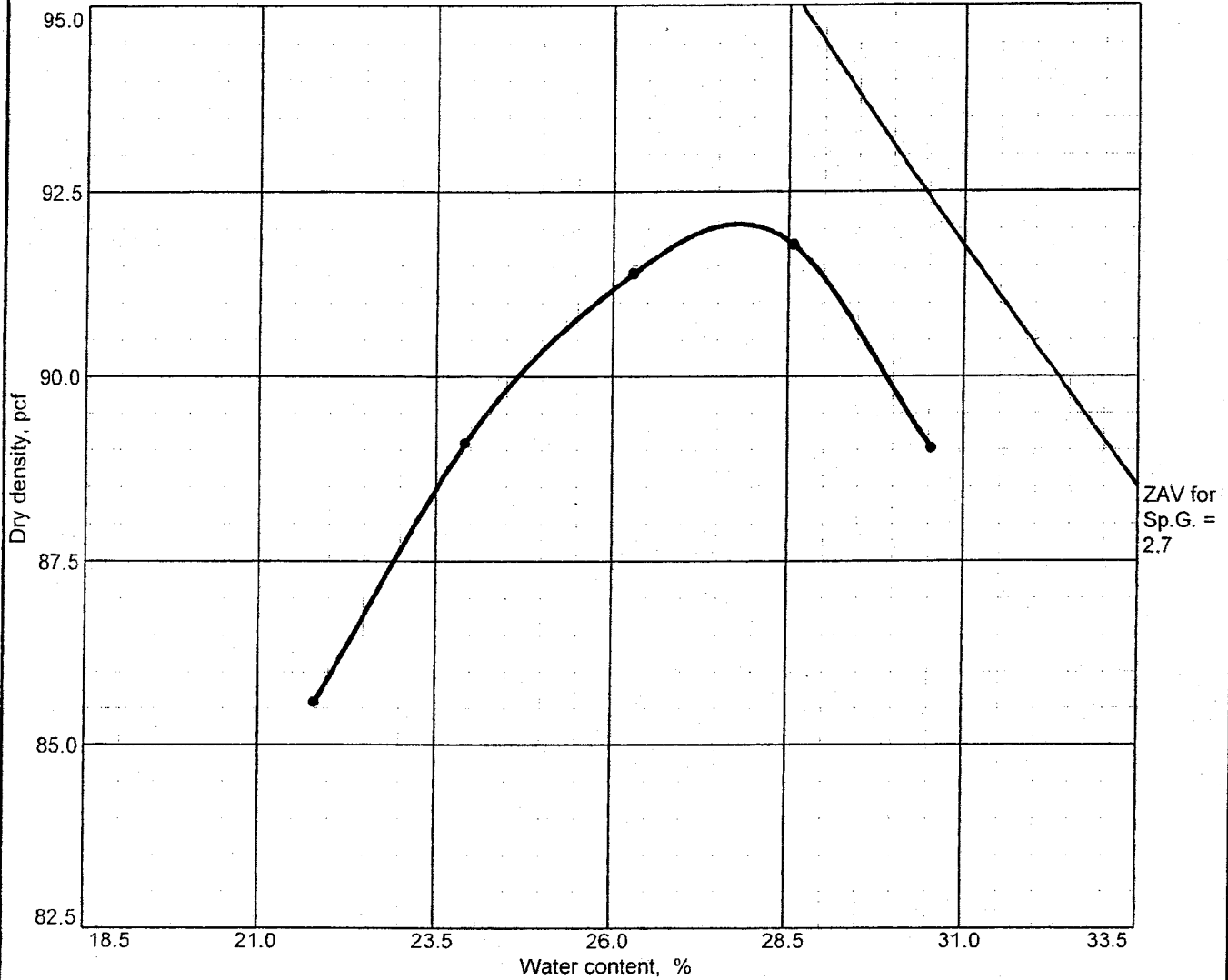

Test specification: ASTM D 698-91 Procedure A Standard

Elev/ Depth	Classification		Nat. Moist.	Sp.G.	LL	PI	% > No.4	% < No.200
	USCS	AASHTO						
10'-15'	MH		34.7%	2.69	56	19	3.2	75.0

TEST RESULTS	MATERIAL DESCRIPTION
Maximum dry density = 92.1 pcf Optimum moisture = 27.8 %	Red Brown Elastic Silt with SAND

Project No. 3043051064- Client:  
 Project: TVA Kingston Gypsum Disposal  
 • Location: K-3 10'-15'

Remarks:

COMPACTION TEST REPORT  
**MACTEC, INC.**

Figure



# COMPACTION TEST REPORT

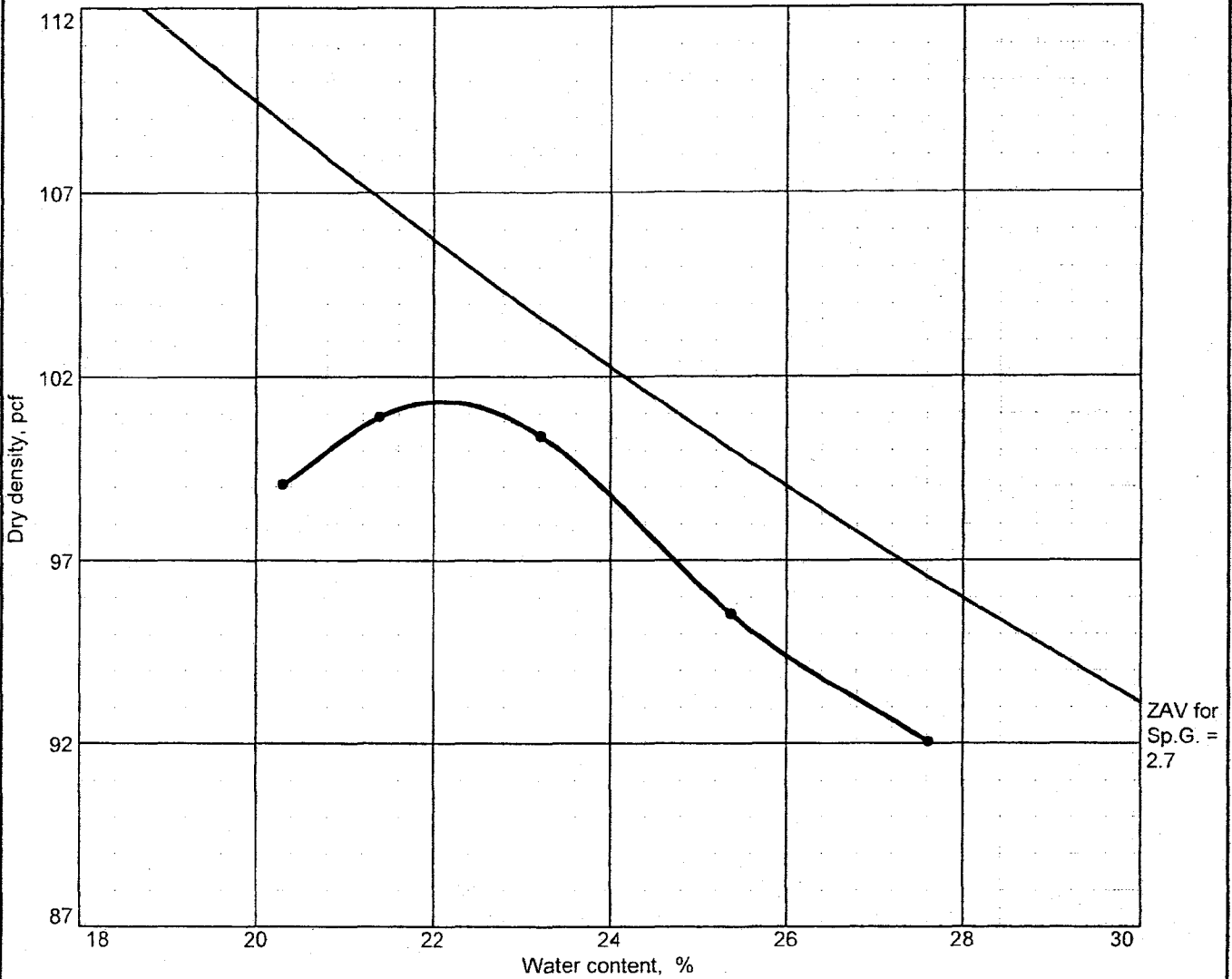

Test specification: ASTM D 698-91 Procedure A Standard

Elev/ Depth	Classification		Nat. Moist.	Sp.G.	LL	PI	% > No.4	% < No.200
	USCS	AASHTO						
10'-15'	ML		25.6%	2.65	43	14	0.0	75.0

TEST RESULTS	MATERIAL DESCRIPTION
Maximum dry density = 101.3 pcf Optimum moisture = 22.1 %	Red Brown Silt with SAND
Project No. 3043051064- Client: Project: TVA Kingston Gypsum Disposal ● Location: K-6 10'-15'	Remarks: 
COMPACTION TEST REPORT <b>MACTEC, INC.</b>	Figure

# COMPACTION TEST REPORT

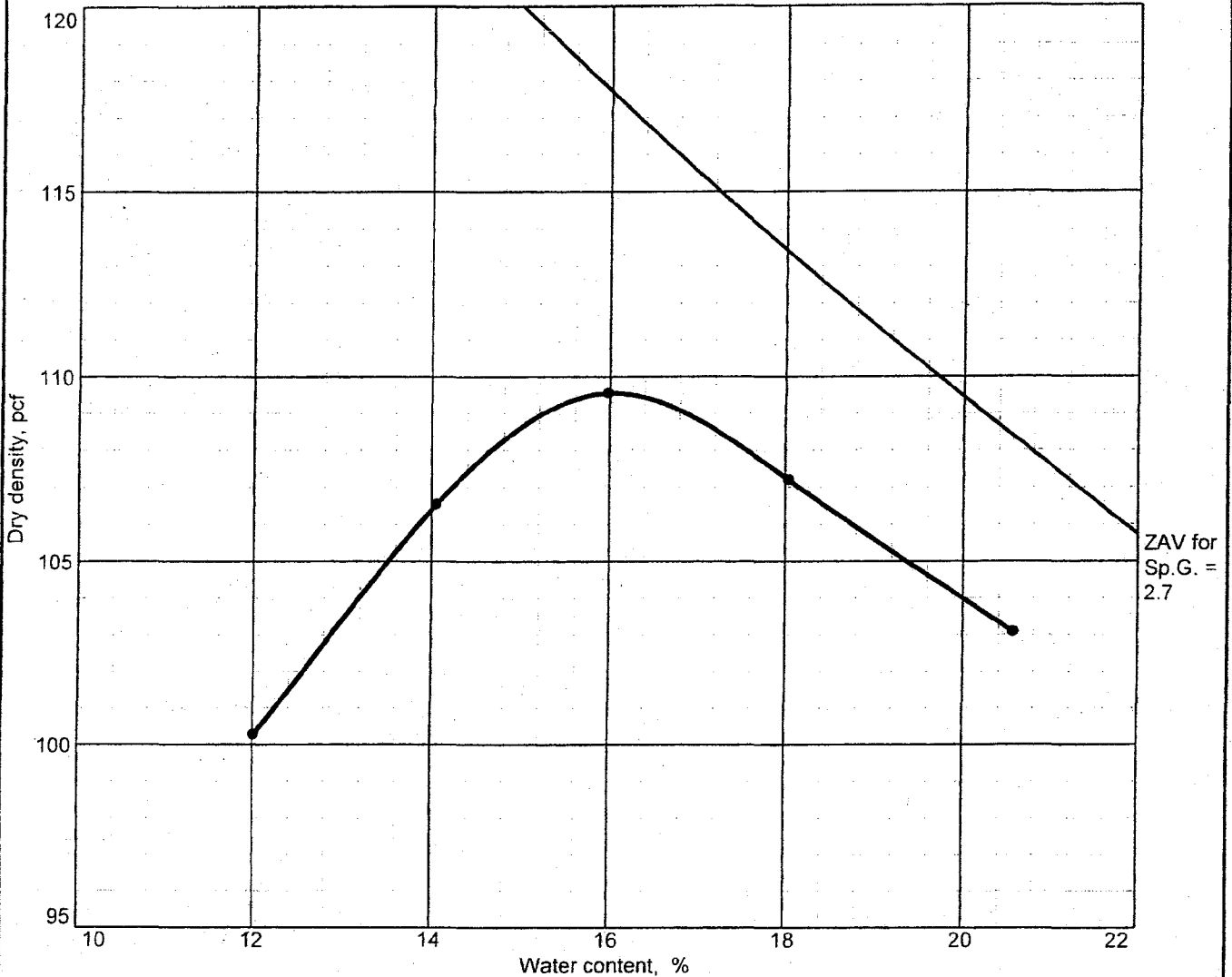

Test specification: ASTM D 698-91 Procedure A Standard

Elev/ Depth	Classification		Nat. Moist.	Sp.G.	LL	PI	% > No.4	% < No.200
	USCS	AASHTO						
10'-15'	CL		22.3%	2.64	31	10	0.0	70.5

TEST RESULTS	MATERIAL DESCRIPTION
Maximum dry density = 109.6 pcf Optimum moisture = 16.0 %	Dark Brown Lean Clay with SAND
Project No. 3043051064- Client: Project: TVA Kingston Gypsum Disposal • Location: K-7 10'-15'	Remarks: <div style="text-align: center; font-size: 2em; font-family: cursive;">CTX</div>
COMPACTION TEST REPORT <b>MACTEC, INC.</b>	Figure

# COMPACTION TEST REPORT

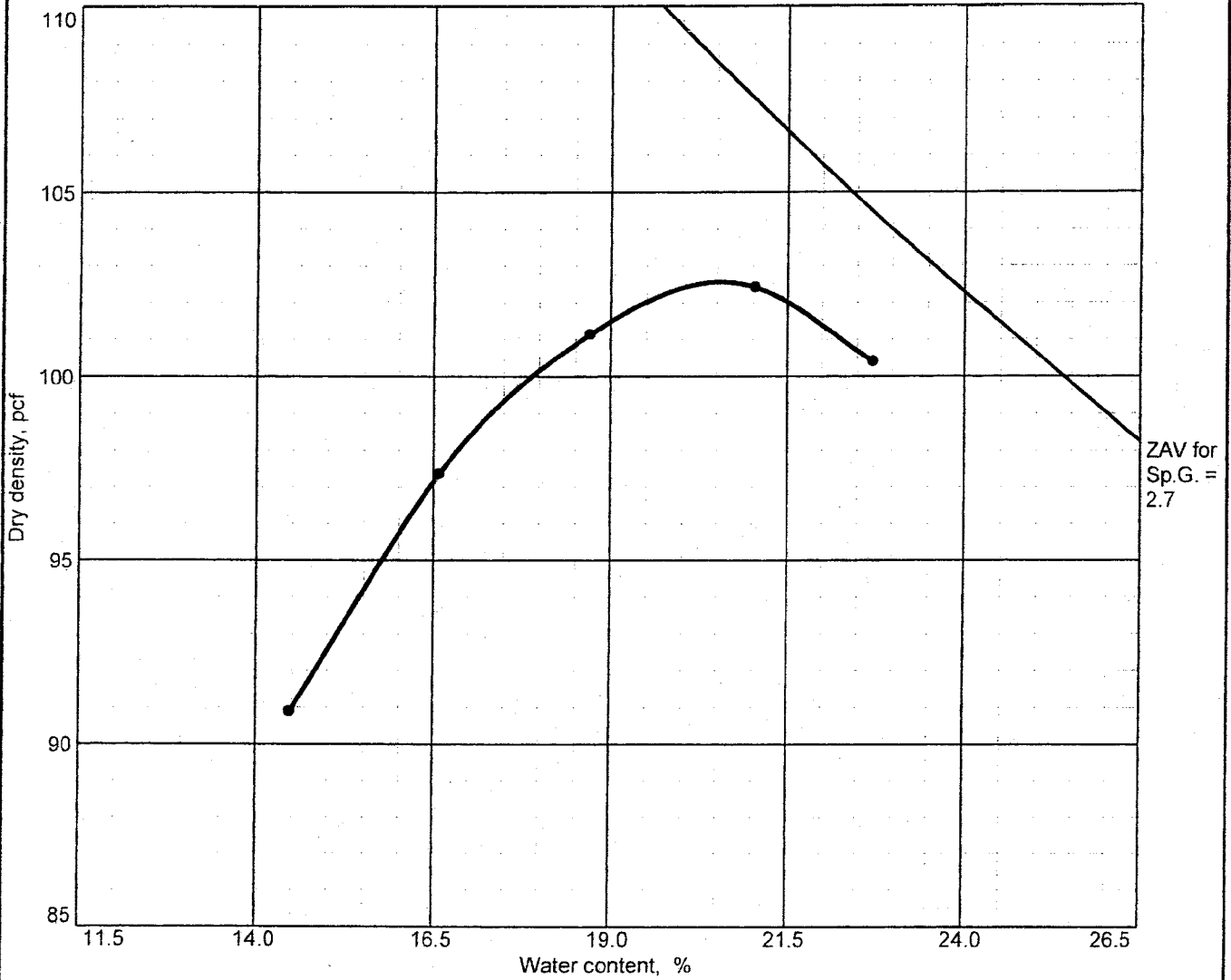

Test specification: ASTM D 698-91 Procedure A Standard

Elev/ Depth	Classification		Nat. Moist.	Sp.G.	LL	PI	% > No.4	% < No.200
	USCS	AASHTO						
10'-15'	CH		22.4%	2.67	51	24	4.4	53.0

TEST RESULTS	MATERIAL DESCRIPTION
Maximum dry density = 102.6 pcf Optimum moisture = 20.6 %	Red Brown Sandy Fat CLAY
Project No. 3043051064- Client: Project: TVA Kingston Gypsum Disposal  • Location: K-8 10'-15'	Remarks: 
COMPACTION TEST REPORT <b>MACTEC, INC.</b>	Figure

# COMPACTION TEST REPORT

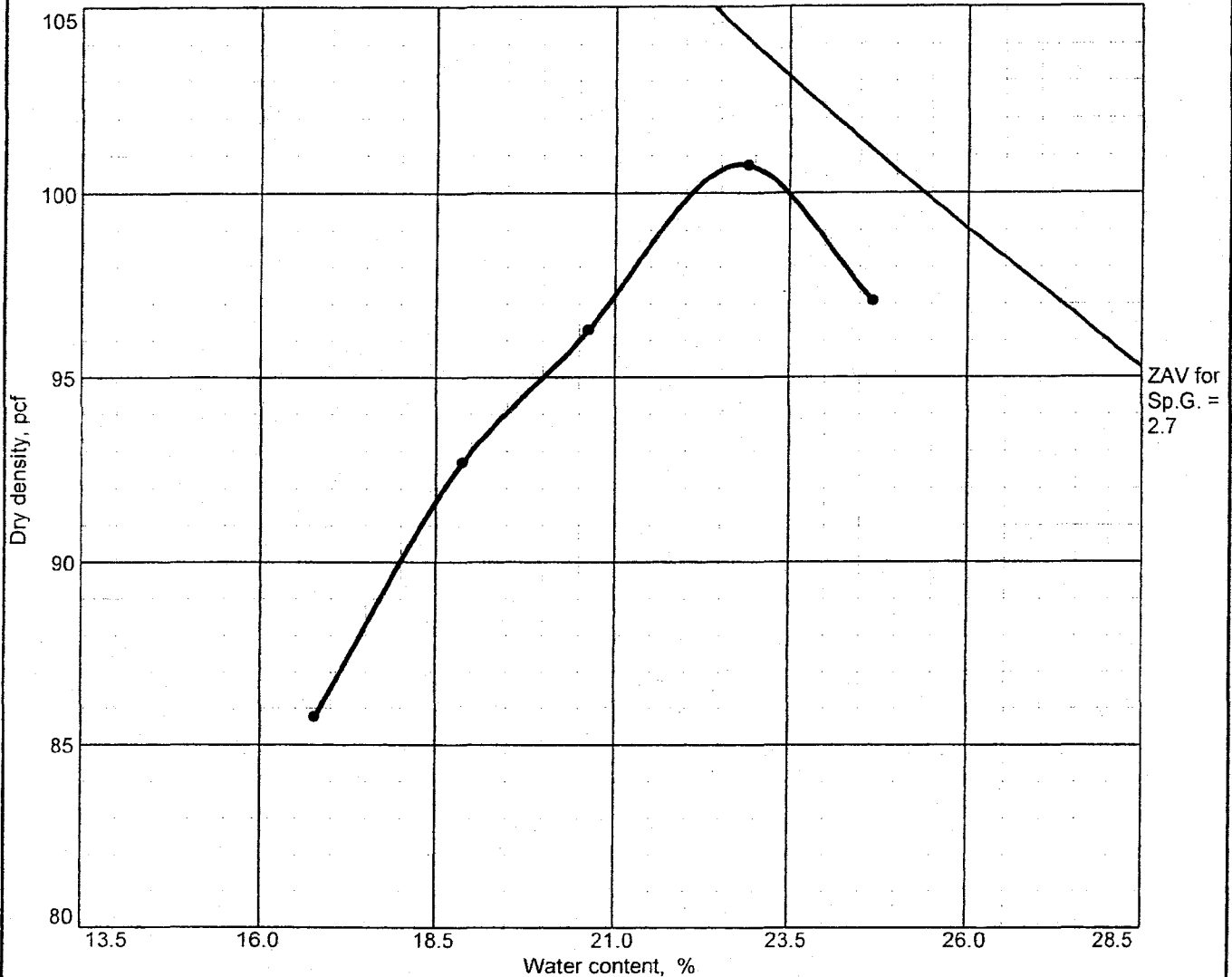

Test specification: ASTM D 698-91 Procedure A Standard

Elev/ Depth	Classification		Nat. Moist.	Sp.G.	LL	PI	% > No.4	% < No.200
	USCS	AASHTO						
10'-15'	<b>MH</b>		28.3%	2.75	52	23	1.3	78.9

TEST RESULTS	MATERIAL DESCRIPTION
Maximum dry density = 100.8 pcf Optimum moisture = 22.8 %	Dark Red Brown Elastic Silt with SAND

<b>Project No.</b> 3043051064- <b>Client:</b> <b>Project:</b> TVA Kingston Gypsum Disposal  ● <b>Location:</b> K-16 10'-15'	<b>Remarks:</b> <div style="text-align: center; font-size: 2em; font-family: cursive;">CTF</div>
--	---

COMPACTION TEST REPORT <b>MACTEC, INC.</b>	Figure
---	--------

# COMPACTION TEST REPORT

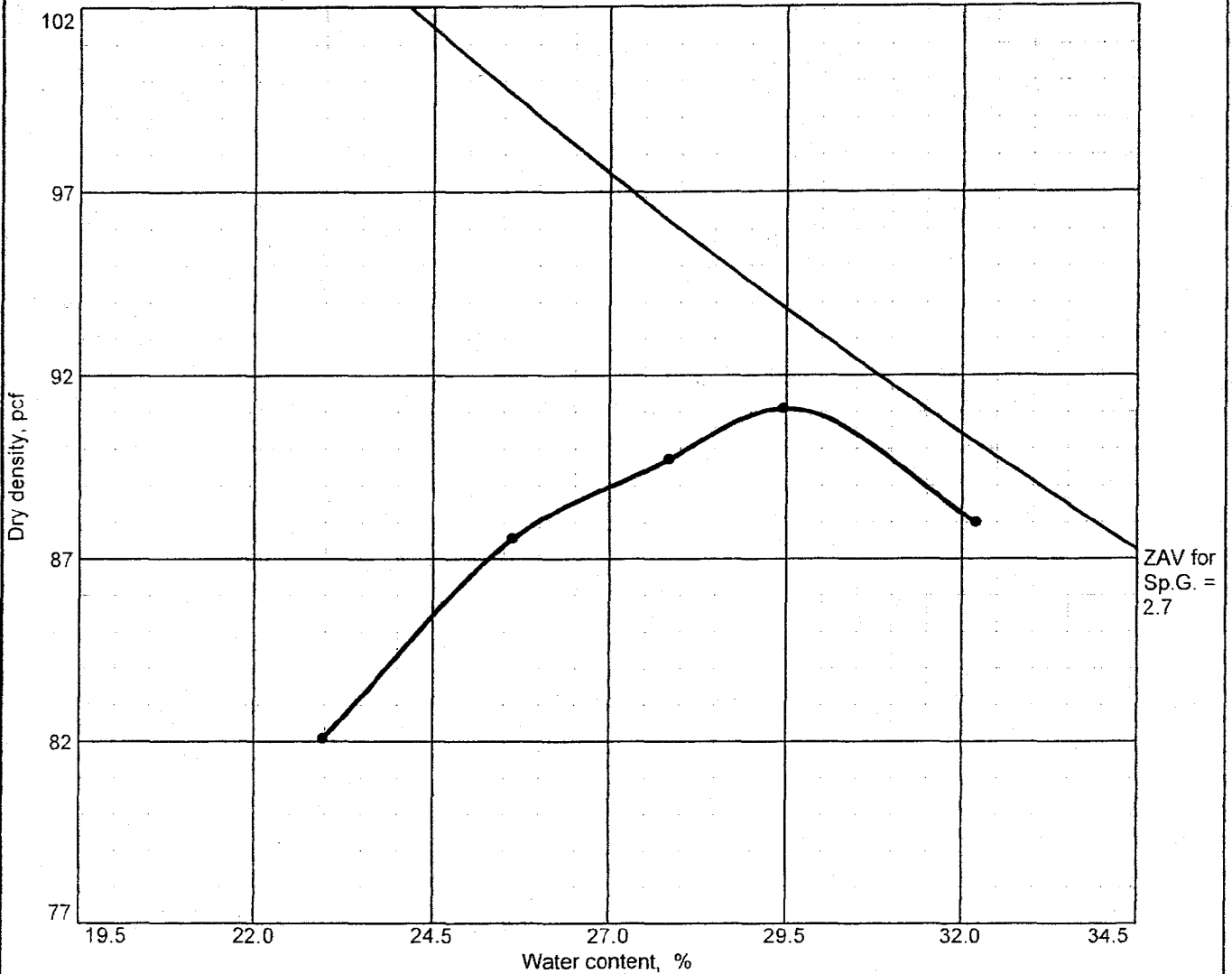

Test specification: ASTM D 698-91 Procedure A Standard

Elev/ Depth	Classification		Nat. Moist.	Sp.G.	LL	PI	% > No.4	% < No.200
	USCS	AASHTO						
10'-15'	MH		30.6 %	2.70	75	35	0.0	89.0

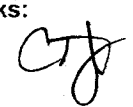
TEST RESULTS	MATERIAL DESCRIPTION
Maximum dry density = 91.1 pcf Optimum moisture = 29.5 %	Red Brown Elastic SILT
Project No. 3043051064- Client: Project: TVA Kingston Gypsum Disposal • Location: K-17 10'-15'	Remarks: 
COMPACTION TEST REPORT <b>MACTEC, INC.</b>	Figure

# COMPACTION TEST REPORT

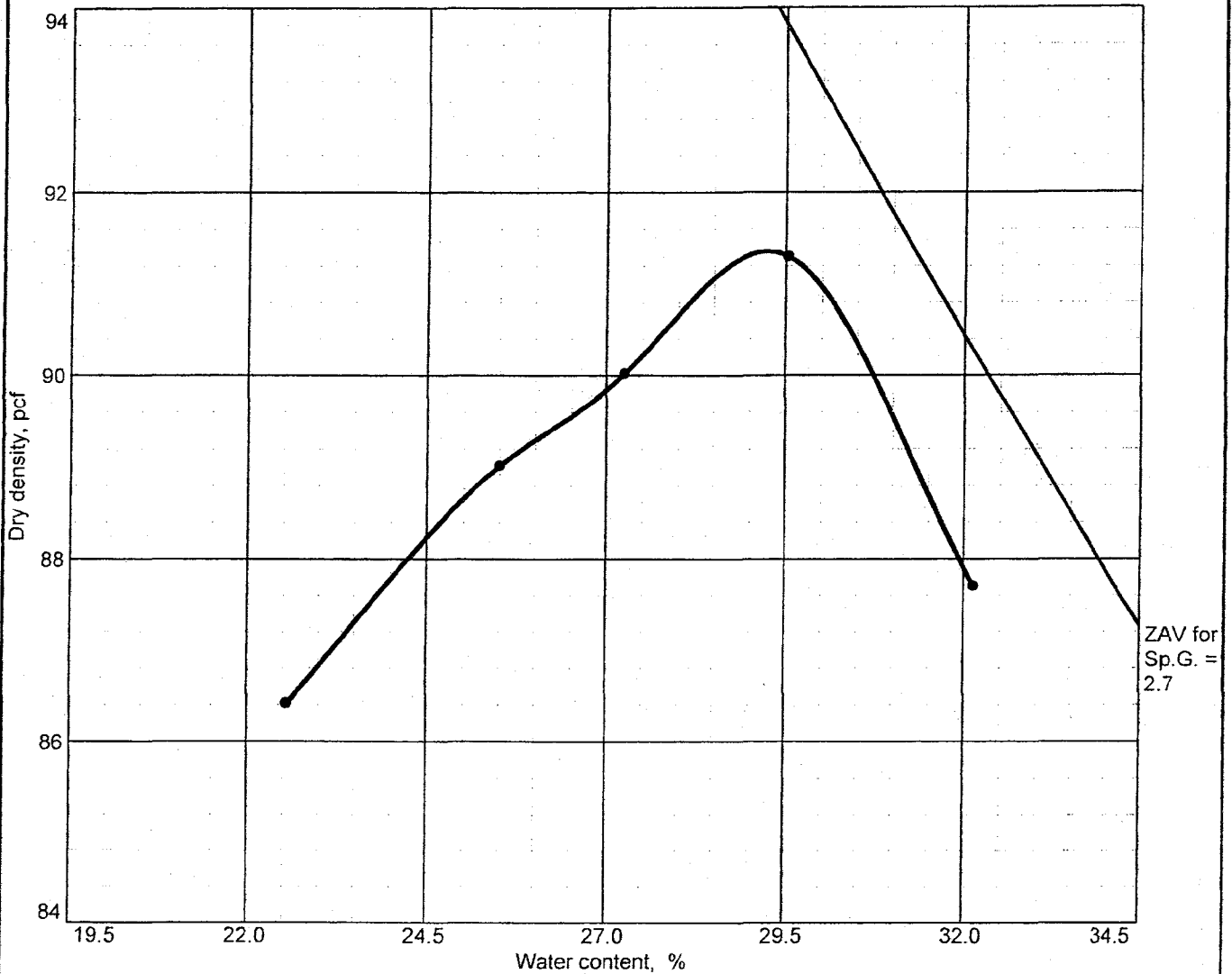

Test specification: ASTM D 698-91 Procedure A Standard

Elev/ Depth	Classification		Nat. Moist.	Sp.G.	LL	PI	% > No.4	% < No.200
	USCS	AASHTO						
10'-15'	MH		31.3%	2.78	71	34	8.4	79.4

TEST RESULTS	MATERIAL DESCRIPTION
Maximum dry density = 91.4 pcf Optimum moisture = 29.2 %	Red Brown Elastic Silt with SAND
Project No. 3043051064- Client: Project: TVA Kingston Gypsum Disposal • Location: K-18 10'-15'	Remarks: <i>CTA</i>
COMPACTION TEST REPORT <b>MACTEC, INC.</b>	Figure

**UNIT WEIGHT TEST RESULTS**

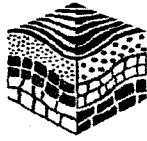

# GeoTesting Express

## GTX TECHNICAL PROCEDURE T-03 UNIT WEIGHT OF SAMPLE

Project No.: GTX G0959	Boring No.: NB-21B
Lab No: 13775	Depth: 31-33 Ft.
Project Name: Kingston Proposed Gypsum Stack	Sample ID: Ud
Tested By: HJ	Reviewed By: JW
Date: 12/14/05	Date: 02/02/06

Total Sample Height, inches	Inside Diameter of Cut Tube, inches	Moisture Content	
1      22.62	Top      2.870 Bottom   2.870 Average   2.870	Tare No.      A-16	
2      22.6		Tare Weight      16.41	grams
3      22.58		Wet Weight + Tare      130.22	grams
Average      22.60		Dry Weight + Tare      103.98	grams
		Moisture Content      30.0	%

Total Weight of Soil + Tube Section	6338.00	grams
Weight of Clean, Dry Tube Section	1713.80	grams
Wet Weight of Soil	10.19	lbs
Volume of Sample	0.085	ft <sup>3</sup>

### RESULT SUMMARY

Moisture Content	30.0	%
Wet Density	120.5	pcf
Dry Density	92.7	pcf

Remarks: \_\_\_\_\_  
 \_\_\_\_\_  
 \_\_\_\_\_



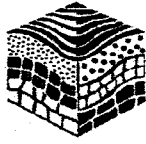

# GeoTesting Express

## GTX TECHNICAL PROCEDURE T-03 UNIT WEIGHT OF SAMPLE

Project No.: GTX G0959  
 Lab No: 13774  
 Project Name: Kingston Proposed Gypsum Stack  
 Tested By: HJ  
 Date: 12/22/05

Boring No.: NB-47BA  
 Depth: 20-22 Ft.  
 Sample ID: Ud  
 Reviewed By: JW  
 Date: 02/02/06

Total Sample Height, inches		Inside Diameter of Cut Tube, inches		Moisture Content	
1	19.65			Tare No.	A-1
2	19.65	Top	2.870	Tare Weight	16.96 grams
3	19.65	Bottom	2.870	Wet Weight + Tare	210.10 grams
Average	19.65	Average	2.870	Dry Weight + Tare	148.50 grams
				Moisture Content	46.8 %

Total Weight of Soil + Tube Section	5111.00	grams
Weight of Clean, Dry Tube Section	1490.10	grams
Wet Weight of Soil	7.98	lbs
Volume of Sample	0.074	ft <sup>3</sup>

### RESULT SUMMARY

Moisture Content	46.8	%
Wet Density	108.5	pcf
Dry Density	73.9	pcf

Remarks:

---



---



---



# GeoTesting Express

## GTX TECHNICAL PROCEDURE T-03 UNIT WEIGHT OF SAMPLE

Project No.: GTX G0959	Boring No.: NB-73WB
Lab No: 13767	Depth: 40-42 Ft.
Project Name: Kingston Proposed Gypsum Stack	Sample ID: Ud
Tested By: HJ	Reviewed By: JW
Date: 12/12/05	Date: 02/02/06

Total Sample Height, inches	Inside Diameter of Cut Tube, inches	Moisture Content
1      20.5	Top      2.870 Bottom   2.870 Average   2.870	Tare No.      M-3
2      20.5		Tare Weight    77.96 <i>grams</i>
3      20.5		Wet Weight + Tare    208.77 <i>grams</i>
Average    20.50		Dry Weight + Tare    176.43 <i>grams</i>
		Moisture Content    32.8    %

Total Weight of Soil + Tube Section	5790.00	<i>grams</i>
Weight of Clean, Dry Tube Section	1611.40	<i>grams</i>
Wet Weight of Soil	9.21	<i>lbs</i>
Volume of Sample	0.077	<i>ft<sup>3</sup></i>

### RESULT SUMMARY

Moisture Content	32.8	%
Wet Density	120.0	<i>pcf</i>
Dry Density	90.4	<i>pcf</i>

Remarks: \_\_\_\_\_  
 \_\_\_\_\_  
 \_\_\_\_\_

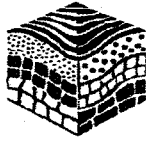

# GeoTesting Express

## GTX TECHNICAL PROCEDURE T-03 UNIT WEIGHT OF SAMPLE

Project No.: GTX G0959	Boring No.: NB-73WBA
Lab No: 13768	Depth: 40-42 Ft.
Project Name: Kingston Proposed Gypsum Stack	Sample ID: Ud
Tested By: HJ	Reviewed By: JW
Date: 12/14/05	Date: 02/02/06

Total Sample Height, inches	Inside Diameter of Cut Tube, inches	Moisture Content	
1      5.57	Top      2.848 Bottom   2.848 Average   2.848	Tare No.      B-29	
2      5.57		Tare Weight      57.99 <i>grams</i>	
3      5.57		Wet Weight + Tare      1216.14 <i>grams</i>	
Average      5.57		Dry Weight + Tare      951.73 <i>grams</i>	
		Moisture Content      29.6      %	

Total Weight of Soil + Tube Section	1158.15	<i>grams</i>
Weight of Clean, Dry Tube Section	0.00	<i>grams</i>
Wet Weight of Soil	2.55	<i>lbs</i>
Volume of Sample	0.021	<i>ft<sup>3</sup></i>

### RESULT SUMMARY

Moisture Content	29.6	%
Wet Density	124.3	<i>pcf</i>
Dry Density	96.0	<i>pcf</i>

Remarks: \_\_\_\_\_  
 \_\_\_\_\_  
 \_\_\_\_\_

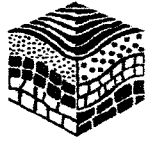

# GeoTesting Express

## GTX TECHNICAL PROCEDURE T-03 UNIT WEIGHT OF SAMPLE

Project No.: GTX G0959	Boring No.: NB-77B
Lab No: 13765	Depth: 11-12.8 Ft.
Project Name: Kingston Proposed Gypsum Stack	Sample ID: Ud
Tested By: HJ	Reviewed By: JW
Date: 12/12/05	Date: 02/02/06

Total Sample Height, inches	Inside Diameter of Cut Tube, inches	Moisture Content	
1 15.13	Top 2.870 Bottom 2.870 Average 2.870	Tare No. M-8	
2 15.09		Tare Weight 75.28	grams
3 15.11		Wet Weight + Tare 178.70	grams
Average 15.11		Dry Weight + Tare 155.63	grams
		Moisture Content 28.7	%

Total Weight of Soil + Tube Section	4195.00	grams
Weight of Clean, Dry Tube Section	1145.80	grams
Wet Weight of Soil	6.72	lbs
Volume of Sample	0.057	ft <sup>3</sup>

### RESULT SUMMARY

Moisture Content	28.7	%
Wet Density	118.8	pcf
Dry Density	92.3	pcf

Remarks: \_\_\_\_\_  
 \_\_\_\_\_  
 \_\_\_\_\_



# GeoTesting Express

## GTX TECHNICAL PROCEDURE T-03 UNIT WEIGHT OF SAMPLE

Project No.: GTX G0959  
 Lab No: 13766  
 Project Name: Kingston Proposed Gypsum Stack  
 Tested By: HJ  
 Date: 12/12/05

Boring No.: NB-77B  
 Depth: 13-15 Ft.  
 Sample ID: Ud  
 Reviewed By: JW  
 Date: 02/02/06

Total Sample Height, inches	Inside Diameter of Cut Tube, inches	Moisture Content
1 15.1	Top 2.870	Tare No. M-5
2 15.05		Tare Weight 74.98 grams
3 15.15	Bottom 2.870	Wet Weight + Tare 155.41 grams
Average 15.10	Average 2.870	Dry Weight + Tare 136.50 grams
		Moisture Content 30.7 %

Total Weight of Soil + Tube Section	4194.00	grams
Weight of Clean, Dry Tube Section	1145.00	grams
Wet Weight of Soil	6.72	lbs
Volume of Sample	0.057	ft <sup>3</sup>

### RESULT SUMMARY

Moisture Content	30.7	%
Wet Density	118.9	pcf
Dry Density	90.9	pcf

Remarks:

---



---



---

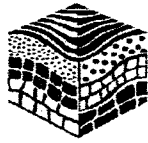

# GeoTesting Express

## GTX TECHNICAL PROCEDURE T-03 UNIT WEIGHT OF SAMPLE

Project No.: GTX G0959  
 Lab No: 13771  
 Project Name: Kingston Proposed Gypsum Stack  
 Tested By: HJ  
 Date: 12/14/05

Boring No.: NB-85B  
 Depth: 28-30 Ft.  
 Sample ID: Ud  
 Reviewed By: JW  
 Date: 02/02/06

Total Sample Height, inches	Inside Diameter of Cut Tube, inches	Moisture Content
1 15.45	Top 2.848 Bottom 2.848 Average 2.848	Tare No. A-33
2 15.45		Tare Weight 17.16 <i>grams</i>
3 15.45		Wet Weight + Tare 104.12 <i>grams</i>
Average 15.45		Dry Weight + Tare 79.70 <i>grams</i>
		Moisture Content 39.0 %

Total Weight of Soil + Tube Section	4134.00	<i>grams</i>
Weight of Clean, Dry Tube Section	1205.70	<i>grams</i>
Wet Weight of Soil	6.46	<i>lbs</i>
Volume of Sample	0.057	<i>ft<sup>3</sup></i>

### RESULT SUMMARY

Moisture Content	39.0	%
Wet Density	113.3	<i>pcf</i>
Dry Density	81.5	<i>pcf</i>

Remarks:

---



---



---



# GeoTesting Express

## GTX TECHNICAL PROCEDURE T-03 UNIT WEIGHT OF SAMPLE

Project No.: GTX G0959	Boring No.: NB-85B
Lab No: 13772	Depth: 30-32 Ft.
Project Name: Kingston Proposed Gypsum Stack	Sample ID: Ud
Tested By: HJ	Reviewed By: JW
Date: 12/14/05	Date: 02/02/06

Total Sample Height, inches	Inside Diameter of Cut Tube, inches	Moisture Content
1 9.03	Top 2.870 Bottom 2.870 Average 2.870	Tare No. A-46
2 9.05		Tare Weight 16.65 <i>grams</i>
3 9		Wet Weight + Tare 123.74 <i>grams</i>
Average 9.03		Dry Weight + Tare 99.01 <i>grams</i>
		Moisture Content 30.0 %

Total Weight of Soil + Tube Section	2530.00	<i>grams</i>
Weight of Clean, Dry Tube Section	687.00	<i>grams</i>
Wet Weight of Soil	4.06	<i>lbs</i>
Volume of Sample	0.034	<i>ft<sup>3</sup></i>

### RESULT SUMMARY

Moisture Content	30.0	%
Wet Density	120.2	<i>pcf</i>
Dry Density	92.5	<i>pcf</i>

Remarks: \_\_\_\_\_  
 \_\_\_\_\_  
 \_\_\_\_\_

**UNCONSOLIDATED UNDRAINED TRIAXIAL COMPRESSION TEST RESULTS**



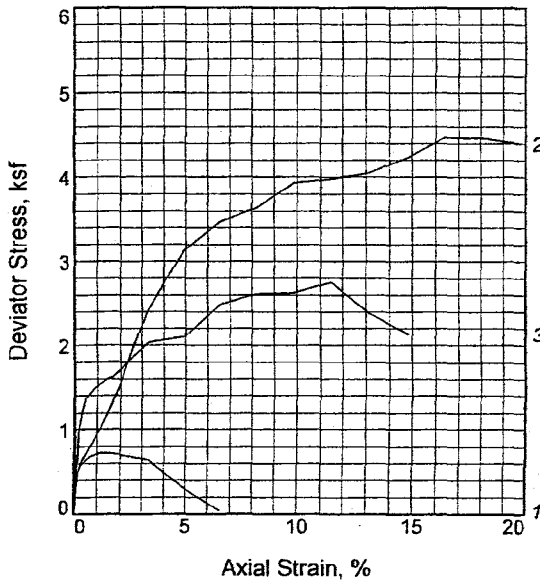
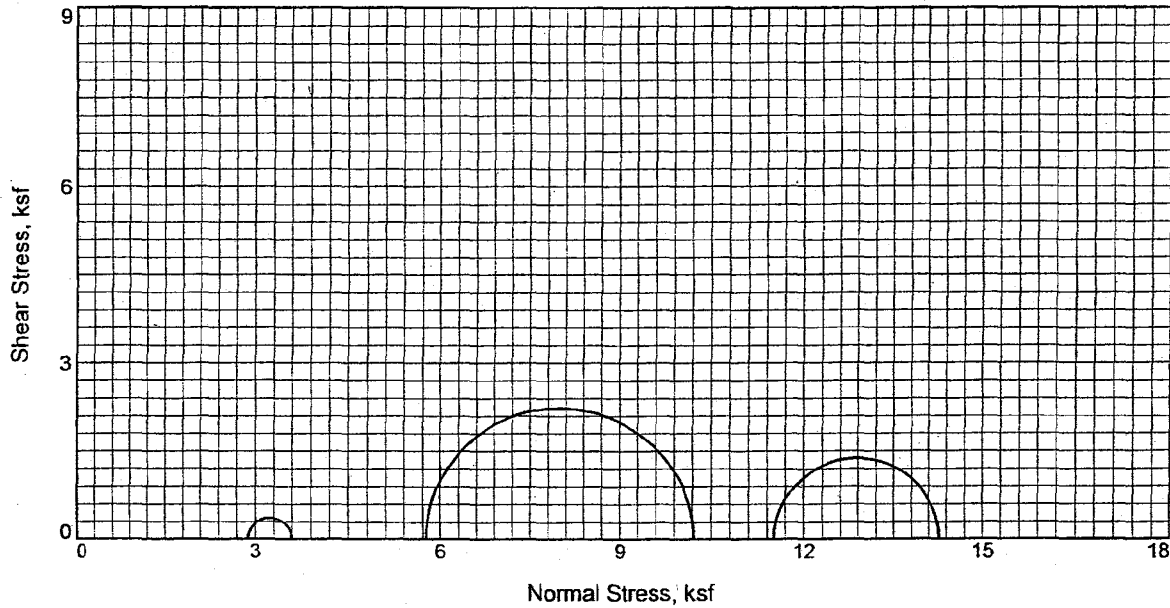

Sample No.	1	2	3	
Initial	Water Content,	39.4	37.1	38.6
	Dry Density, pcf	79.9	82.3	77.4
	Saturation,	98.6	98.3	90.9
	Void Ratio	1.0459	0.9880	1.1127
	Diameter, in.	2.82	2.81	2.80
	Height, in.	6.11	6.09	6.08
At Test	Water Content,	39.9	37.7	42.5
	Dry Density, pcf	79.9	82.3	77.4
	Saturation,	100.0	100.0	100.0
	Void Ratio	1.0459	0.9880	1.1127
	Diameter, in.	2.82	2.81	2.80
	Height, in.	6.11	6.09	6.08
Strain rate, in./min.	0.02	0.02	0.02	
Back Pressure, ksf	2.9	2.9	2.9	
Cell Pressure, ksf	5.8	8.6	14.4	
Fail. Stress, ksf	0.7	4.5	2.8	
Ult. Stress, ksf				
$\sigma_1$ Failure, ksf	3.6	10.2	14.3	
$\sigma_3$ Failure, ksf	2.9	5.8	11.5	

**Type of Test:**

Unconsolidated Undrained

**Sample Type:** undisturbed sample

**Description:**

**Assumed Specific Gravity=** 2.62

**Remarks:**

**Client:** TVA

**Project:** TVA Kingston - Proposed Gypsum Stack

**Location:** NB-18

**Sample Number:** UD-2, 3 & 4 (UU)

**Depth:** 9'-18.5'

**Proj. No.:** 3043051021

**Date:**

TRIAxIAL SHEAR TEST REPORT

**MACTEC, INC.**

Figure \_\_\_\_\_

Tested By: Alexander \_\_\_\_\_

Checked By: Hamlett \_\_\_\_\_

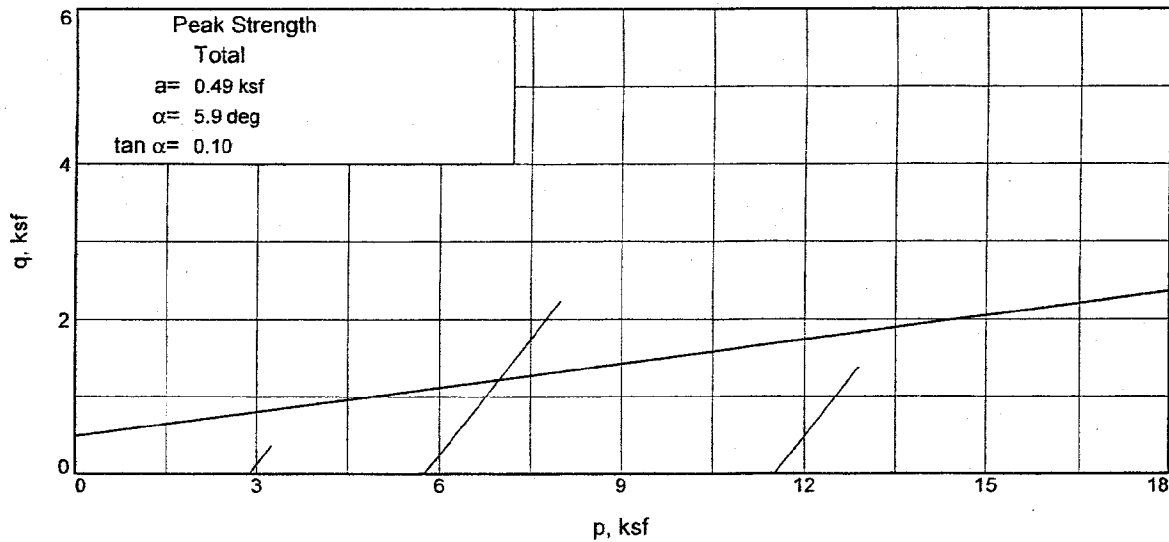
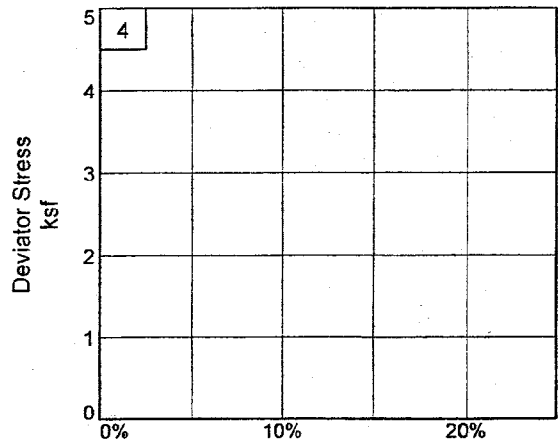
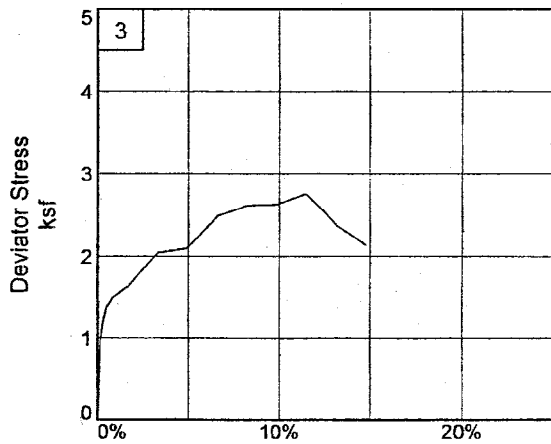
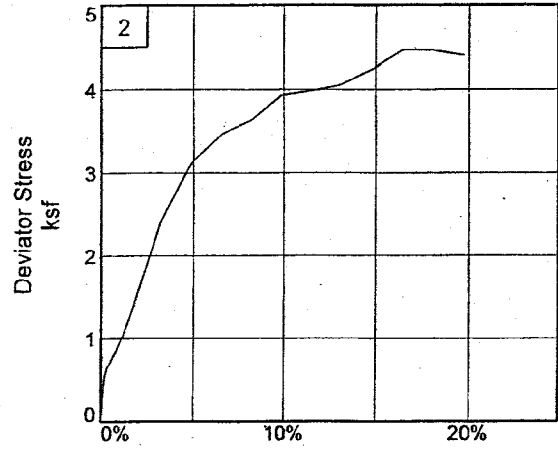
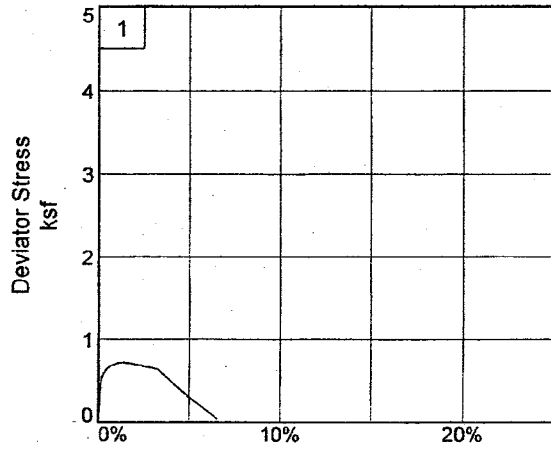

Client: TVA

Project: TVA Kingston - Proposed Gypsum Stack

Location: NB-18

Depth: 9'-18.5'

Sample Number: UD-2, 3 & 4 (UU)

Project No.: 3043051021

Figure \_\_\_\_\_

**MACTEC, INC.**

Tested By: Alexander \_\_\_\_\_

Checked By: Hamlett \_\_\_\_\_

**TRIAxIAL COMPRESSION TEST**

Unconsolidated Undrained

9/13/2005

9:03 PM

Date:  
 Client: TVA  
 Project: TVA Kingston - Proposed Gypsum Stack  
 Project No.: 3043051021  
 Location: NB-18  
 Depth: 9'-18.5' Sample Number: UD-2, 3 & 4 (UU)  
 Description:  
 Remarks:  
 Type of Sample: undisturbed sample  
 Specific Gravity=2.62 LL= PL= PI=  
 Test Method: COE uniform strain

Parameters for Specimen No. 1			
Specimen Parameter	Initial	Saturated	Final
Moisture content: Moist soil+tare, gms.	1118.300		642.950
Moisture content: Dry soil+tare, gms.	802.500		447.100
Moisture content: Tare, gms.	0.000		14.010
Moisture, %	39.4	39.9	45.2
Moist specimen weight, gms.	1118.3		
Diameter, in.	2.82	2.82	
Area, in. <sup>2</sup>	6.25	6.25	
Height, in.	6.11	6.11	
Net decrease in height, in.		0.00	
Wet Density, pcf	111.4	111.9	
Dry density, pcf	79.9	79.9	
Void ratio	1.0459	1.0459	
Saturation, %	98.6	100.0	

Test Readings for Specimen No. 1

Load ring constant = 0.72 lbs. per input unit  
 Cell pressure = 40.00 psi (5.76 ksf)  
 Back pressure = 20.00 psi (2.88 ksf)  
 Effective confining stress = 2.88 ksf  
 Strain rate, in./min. = 0.02  
 Fail. Stress = 0.72 ksf at reading no. 7

**Test Readings for Specimen No. 1**

No.	Def. Dial in.	Load Dial	Load lbs.	Strain %	Deviator Stress ksf	Minor Princ. Stress ksf	Major Princ. Stress ksf	1:3 Ratio	P ksf	Q ksf
0	0.0000	0.0	0.0	0.0	0.00	2.88	2.88	1.00		2.88
1	0.0100	31.0	22.3	0.2	0.51	2.88	3.39	1.18		3.14
2	0.0200	36.0	25.9	0.3	0.59	2.88	3.47	1.21		3.18
3	0.0300	39.0	28.1	0.5	0.64	2.88	3.52	1.22		3.20
4	0.0400	41.0	29.5	0.7	0.68	2.88	3.56	1.23		3.22
5	0.0500	42.0	30.2	0.8	0.69	2.88	3.57	1.24		3.23
6	0.0600	43.0	31.0	1.0	0.71	2.88	3.59	1.25		3.23
7	0.0700	44.0	31.7	1.1	0.72	2.88	3.60	1.25		3.24
8	0.0800	44.0	31.7	1.3	0.72	2.88	3.60	1.25		3.24
9	0.0900	44.0	31.7	1.5	0.72	2.88	3.60	1.25		3.24
10	0.1000	44.0	31.7	1.6	0.72	2.88	3.60	1.25		3.24
11	0.2000	40.0	28.8	3.3	0.64	2.88	3.52	1.22		3.20
12	0.3000	20.0	14.4	4.9	0.32	2.88	3.20	1.11		3.04
13	0.4000	3.0	2.2	6.5	0.05	2.88	2.93	1.02		2.90

**Parameters for Specimen No. 2**

Specimen Parameter	Initial	Saturated	Final
Moisture content: Moist soil+tare, gms.	1119.600		646.220
Moisture content: Dry soil+tare, gms.	816.900		468.140
Moisture content: Tare, gms.	0.000		13.530
Moisture, %	37.1	37.7	39.2
Moist specimen weight, gms.	1119.6		
Diameter, in.	2.81	2.81	
Area, in. <sup>2</sup>	6.21	6.21	
Height, in.	6.09	6.09	
Net decrease in height, in.		0.00	
Wet Density, pcf	112.8	113.3	
Dry density, pcf	82.3	82.3	
Void ratio	0.9880	0.9880	
Saturation, %	98.3	100.0	

**Test Readings for Specimen No. 2**

Load ring constant = 0.72 lbs. per input unit  
 Cell pressure = 60.00 psi (8.64 ksf)  
 Back pressure = 20.00 psi (2.88 ksf)  
 Effective confining stress = 5.76 ksf  
 Strain rate, in./min. = 0.02  
 Fail. Stress = 4.47 ksf at reading no. 19

No.	Def. Dial in.	Load Dial	Load lbs.	Strain %	Deviator Stress ksf	Minor Princ. Stress ksf	Major Princ. Stress ksf	1:3 Ratio	P ksf	Q ksf
0	0.0000	0.0	0.0	0.0	0.00	5.76	5.76	1.00		5.76
1	0.0100	31.0	22.3	0.2	0.52	5.76	6.28	1.09		6.02
2	0.0200	39.0	28.1	0.3	0.65	5.76	6.41	1.11		6.08
3	0.0300	43.0	31.0	0.5	0.71	5.76	6.47	1.12		6.12
4	0.0400	48.0	34.6	0.7	0.80	5.76	6.56	1.14		6.16
5	0.0500	52.0	37.4	0.8	0.86	5.76	6.62	1.15		6.19
6	0.0600	57.0	41.0	1.0	0.94	5.76	6.70	1.16		6.23
7	0.0700	61.0	43.9	1.1	1.01	5.76	6.77	1.17		6.26

MACTEC, INC.

**Test Readings for Specimen No. 2**

No.	Def. Dial in.	Load Dial	Load lbs.	Strain %	Deviator Stress ksf	Minor Princ. Stress ksf	Major Princ. Stress ksf	1:3 Ratio	P ksf	Q ksf
8	0.0800	67.0	48.2	1.3	1.10	5.76	6.86	1.19		6.31
9	0.0900	73.0	52.6	1.5	1.20	5.76	6.96	1.21		6.36
10	0.1000	79.0	56.9	1.6	1.30	5.76	7.06	1.23		6.41
11	0.2000	150.0	108.0	3.3	2.42	5.76	8.18	1.42		6.97
12	0.3000	197.0	141.8	4.9	3.13	5.76	8.89	1.54		7.32
13	0.4000	222.0	159.8	6.6	3.47	5.76	9.23	1.60		7.49
14	0.5000	237.0	170.6	8.2	3.63	5.76	9.39	1.63		7.58
15	0.6000	261.0	187.9	9.8	3.93	5.76	9.69	1.68		7.73
16	0.7000	269.0	193.7	11.5	3.98	5.76	9.74	1.69		7.75
17	0.8000	279.0	200.9	13.1	4.05	5.76	9.81	1.70		7.78
18	0.9000	297.0	213.8	14.8	4.23	5.76	9.99	1.73		7.87
19	1.0000	320.0	230.4	16.4	4.47	5.76	10.23	1.78		7.99
20	1.1000	326.0	234.7	18.0	4.46	5.76	10.22	1.77		7.99
21	1.2000	328.0	236.2	19.7	4.40	5.76	10.16	1.76		7.96

**Parameters for Specimen No. 2**

Specimen Parameter	Initial	Saturated	Final
Moisture content: Moist soil+tare, gms.	1055.500		550.410
Moisture content: Dry soil+tare, gms.	761.600		388.030
Moisture content: Tare, gms.	0.000		14.010
Moisture, %	38.6	42.5	43.4
Moist specimen weight, gms.	1055.5		
Diameter, in.	2.80	2.80	
Area, in. <sup>2</sup>	6.16	6.16	
Height, in.	6.08	6.08	
Net decrease in height, in.		0.00	
Wet Density, pcf	107.3	110.3	
Dry density, pcf	77.4	77.4	
Void ratio	1.1127	1.1127	
Saturation, %	90.9	100.0	

**Test Readings for Specimen No. 3**

Load ring constant = 0.72 lbs. per input unit  
 Cell pressure = 100.00 psi (14.40 ksf)  
 Back pressure = 20.00 psi (2.88 ksf)  
 Effective confining stress = 11.52 ksf  
 Strain rate, in./min. = 0.02  
 Fail. Stress = 2.75 ksf at reading no. 16

No.	Def. Dial in.	Load Dial	Load lbs.	Strain %	Deviator Stress ksf	Minor Princ. Stress ksf	Major Princ. Stress ksf	1:3 Ratio	P ksf	Q ksf
0	0.0000	0.0	0.0	0.0	0.00	11.52	11.52	1.00		11.52
1	0.0100	57.0	41.0	0.2	0.96	11.52	12.48	1.08		12.00
2	0.0200	72.0	51.8	0.3	1.21	11.52	12.73	1.10		12.12
3	0.0300	82.0	59.0	0.5	1.37	11.52	12.89	1.12		12.21
4	0.0400	85.0	61.2	0.7	1.42	11.52	12.94	1.12		12.23
5	0.0500	89.0	64.1	0.8	1.49	11.52	13.01	1.13		12.26
6	0.0600	91.0	65.5	1.0	1.52	11.52	13.04	1.13		12.28
7	0.0700	93.0	67.0	1.2	1.55	11.52	13.07	1.13		12.29

Test Readings for Specimen No. 3

No.	Def. Dial in.	Load Dial	Load lbs.	Strain %	Deviator Stress ksf	Minor Princ. Stress ksf	Major Princ. Stress ksf	1:3 Ratio	P ksf	Q ksf
8	0.0800	95.0	68.4	1.3	1.58	11.52	13.10	1.14		12.31
9	0.0900	97.0	69.8	1.5	1.61	11.52	13.13	1.14		12.32
10	0.1000	98.0	70.6	1.6	1.62	11.52	13.14	1.14		12.33
11	0.2000	125.0	90.0	3.3	2.03	11.52	13.55	1.18		12.54
12	0.3000	131.0	94.3	4.9	2.10	11.52	13.62	1.18		12.57
13	0.4000	158.0	113.8	6.6	2.48	11.52	14.00	1.22		12.76
14	0.5000	169.0	121.7	8.2	2.61	11.52	14.13	1.23		12.82
15	0.6000	173.0	124.6	9.9	2.62	11.52	14.14	1.23		12.83
16	0.7000	185.0	133.2	11.5	2.75	11.52	14.27	1.24		12.90
17	0.8000	163.0	117.4	13.2	2.38	11.52	13.90	1.21		12.71
18	0.9000	149.0	107.3	14.8	2.14	11.52	13.66	1.19		12.59

MACTEC, INC.

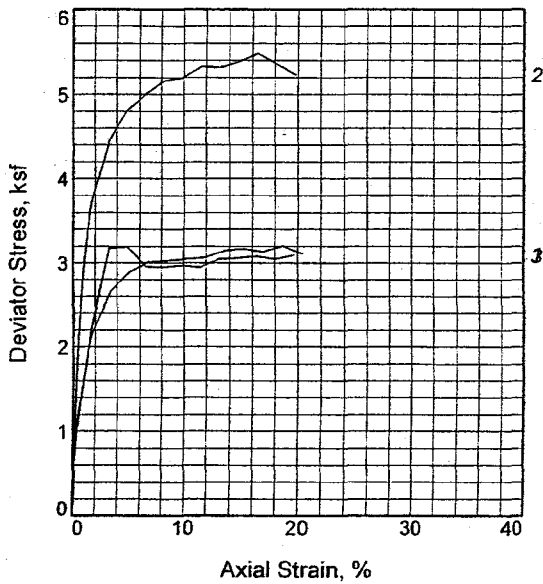
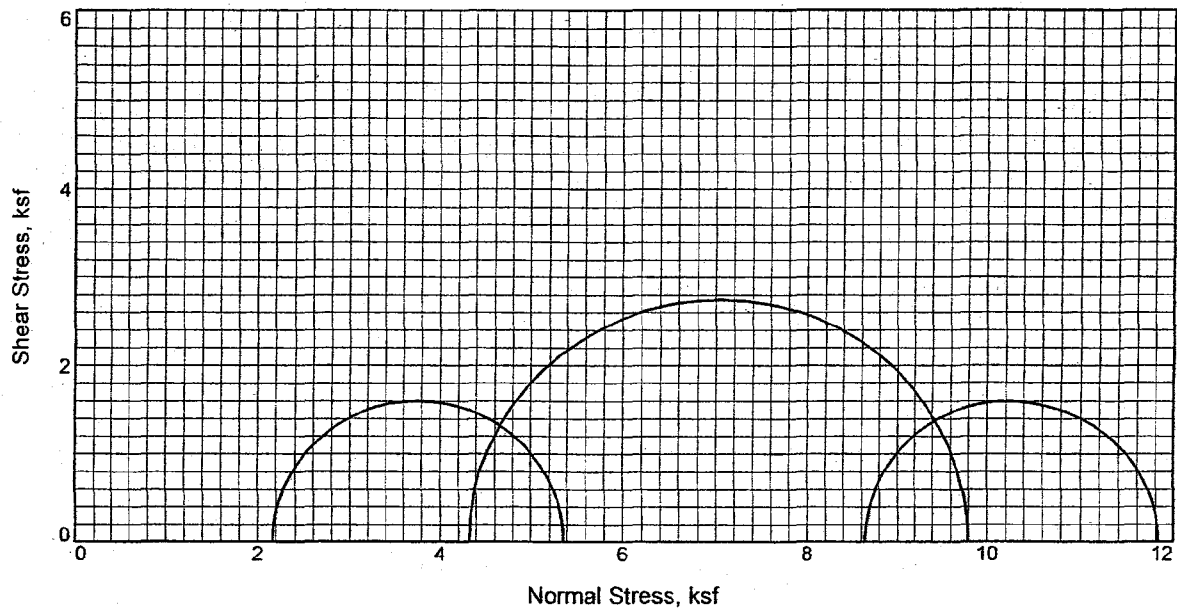

Sample No.		1	2	3
Initial	Water Content,	28.2	24.9	34.2
	Dry Density, pcf	94.4	93.5	86.8
	Saturation,	99.3	85.7	100.0
	Void Ratio	0.7519	0.7700	0.9067
	Diameter, in.	2.82	2.85	2.85
	Height, in.	5.88	6.05	6.09
At Test	Water Content,	28.4	29.1	34.2
	Dry Density, pcf	94.4	93.5	86.8
	Saturation,	100.0	100.0	100.0
	Void Ratio	0.7519	0.7700	0.9067
	Diameter, in.	2.82	2.85	2.85
	Height, in.	5.88	6.05	6.09
Strain rate, in./min.		0.02		0.02
Back Pressure, ksf		4.3	4.3	4.3
Cell Pressure, ksf		6.5	8.6	13.0
Fail. Stress, ksf		3.2	5.5	3.2
Ult. Stress, ksf				
$\sigma_1$	Failure, ksf	5.4	9.8	11.8
$\sigma_3$	Failure, ksf	2.2	4.3	8.6

**Type of Test:**

Unconsolidated Undrained

**Sample Type:** undisturbed

**Description:**

**Assumed Specific Gravity=** 2.65

**Remarks:**

**Client:** TVA

**Project:** TVA Kingston - Proposed Gypsum Stack

**Location:** NB-21A

**Sample Number:** UD-1, 2 & 3 (UU)

**Depth:** 15'-23'

**Proj. No.:** 3043051021

**Date:**

TRIAXIAL SHEAR TEST REPORT

**MACTEC, INC.**

Figure \_\_\_\_\_

Tested By: Alexander \_\_\_\_\_

Checked By: Hamlett \_\_\_\_\_

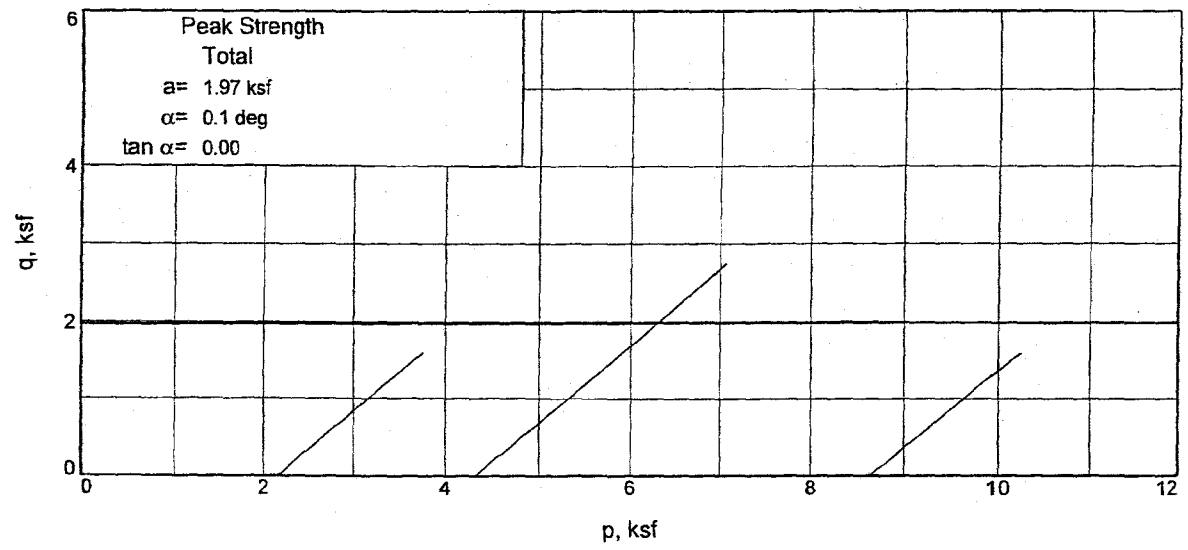
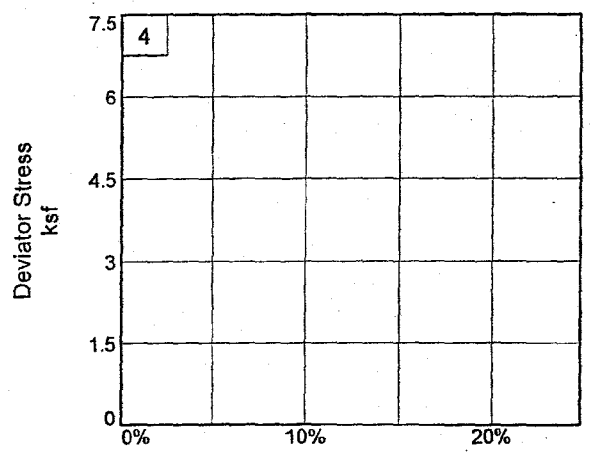
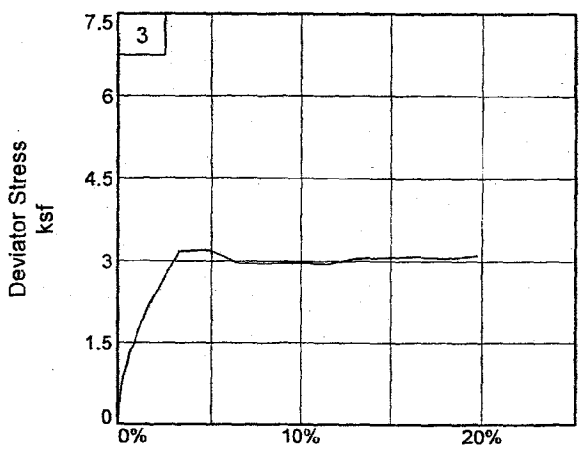
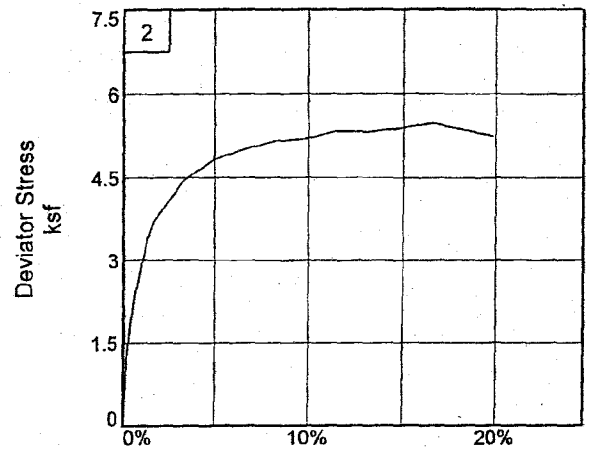
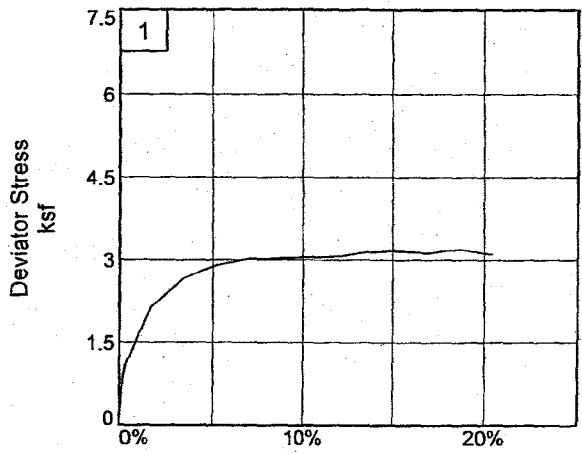

**Client:** TVA  
**Project:** TVA Kingston - Proposed Gypsum Stack  
**Location:** NB-21A      **Depth:** 15'-23'      **Sample Number:** UD-1, 2 & 3 (UU)  
**Project No.:** 3043051021      **Figure** \_\_\_\_\_      **MACTEC, INC.**

**Tested By:** Alexander \_\_\_\_\_      **Checked By:** Hamlett \_\_\_\_\_



TRIAxIAL COMPRESSION TEST  
Unconsolidated Undrained

9/13/2005  
9:15 PM

Date:  
Client: TVA  
Project: TVA Kingston - Proposed Gypsum Stack  
Project No.: 3043051021  
Location: NB-21A  
Depth: 15'-23' Sample Number: UD-1, 2 & 3 (UU)  
Description:  
Remarks:  
Type of Sample: undisturbed  
Specific Gravity=2.65 LL= PL= PI=  
Test Method: COE uniform strain

Parameters for Specimen No. 1

Specimen Parameter	Initial	Saturated	Final
Moisture content: Moist soil+tare, gms.	1170.100		637.780
Moisture content: Dry soil+tare, gms.	912.940		492.750
Moisture content: Tare, gms.	0.000		14.200
Moisture, %	28.2	28.4	30.3
Moist specimen weight, gms.	1170.1		
Diameter, in.	2.82	2.82	
Area, in. <sup>2</sup>	6.26	6.26	
Height, in.	5.88	5.88	
Net decrease in height, in.		0.00	
Wet Density, pcf	121.0	121.2	
Dry density, pcf	94.4	94.4	
Void ratio	0.7519	0.7519	
Saturation, %	99.3	100.0	

Test Readings for Specimen No. 1

Load ring constant = 0.72 lbs. per input unit  
Cell pressure = 45.00 psi (6.48 ksf)  
Back pressure = 30.00 psi (4.32 ksf)  
Effective confining stress = 2.16 ksf  
Strain rate, in./min. = 0.02  
Fail. Stress = 3.20 ksf at reading no. 20

1257 Readings for Specimen No. 1

No.	Def. Dial in.	Load Dial	Load lbs.	Strain %	Deviator Stress ksf	Minor Princ. Stress ksf	Major Princ. Stress ksf	1:3 Ratio	P ksf	Q ksf
0	0.0000	0.0	0.0	0.0	0.00	2.16	2.16	1.00		2.16
1	0.0100	49.0	35.3	0.2	0.81	2.16	2.97	1.37		2.56
2	0.0200	67.0	48.2	0.3	1.11	2.16	3.27	1.51		2.71
3	0.0300	75.0	54.0	0.5	1.24	2.16	3.40	1.57		2.78
4	0.0400	84.0	60.5	0.7	1.38	2.16	3.54	1.64		2.85
5	0.0500	92.0	66.2	0.9	1.51	2.16	3.67	1.70		2.91
6	0.0600	101.0	72.7	1.0	1.65	2.16	3.81	1.77		2.99
7	0.0700	109.0	78.5	1.2	1.78	2.16	3.94	1.83		3.05
8	0.0800	118.0	85.0	1.4	1.93	2.16	4.09	1.89		3.12
9	0.0900	125.0	90.0	1.5	2.04	2.16	4.20	1.94		3.18
10	0.1000	132.0	95.0	1.7	2.15	2.16	4.31	1.99		3.23
11	0.2000	166.0	119.5	3.4	2.65	2.16	4.81	2.23		3.49
12	0.3000	184.0	132.5	5.1	2.89	2.16	5.05	2.34		3.61
13	0.4000	195.0	140.4	6.8	3.01	2.16	5.17	2.39		3.66
14	0.5000	200.0	144.0	8.5	3.03	2.16	5.19	2.40		3.67
15	0.6000	205.0	147.6	10.2	3.05	2.16	5.21	2.41		3.68
16	0.7000	210.0	151.2	11.9	3.06	2.16	5.22	2.42		3.69
17	0.8000	220.0	158.4	13.6	3.15	2.16	5.31	2.46		3.73
18	0.9000	226.0	162.7	15.3	3.17	2.16	5.33	2.47		3.74
19	1.0000	228.0	164.2	17.0	3.13	2.16	5.29	2.45		3.73
20	1.1000	238.0	171.4	18.7	3.20	2.16	5.36	2.48		3.76
21	1.2000	236.0	169.9	20.4	3.11	2.16	5.27	2.44		3.71

**Table 3. Test Results for Specimen No. 2**

Specimen Parameter	Initial	Saturated	Final
Moisture content: Moist soil+tare, gms.	1183.200		695.390
Moisture content: Dry soil+tare, gms.	947.400		564.140
Moisture content: Tare, gms.	0.000		110.760
Moisture, %	24.9	29.1	28.9
Moist specimen weight, gms.	1183.2		
Diameter, in.	2.85	2.85	
Area, in. <sup>2</sup>	6.38	6.38	
Height, in.	6.05	6.05	
Net decrease in height, in.		0.00	
Wet Density, pcf	116.7	120.6	
Dry density, pcf	93.5	93.5	
Void ratio	0.7700	0.7700	
Saturation, %	85.7	100.0	

**Test Readings for Specimen No. 2**

Load ring constant = 0.72 lbs. per input unit  
 Cell pressure = 60.00 psi (8.64 ksf)  
 Back pressure = 30.00 psi (4.32 ksf)  
 Effective confining stress = 4.32 ksf  
 Fail. Stress = 5.48 ksf at reading no. 19

No.	Def. Dial in.	Load Dial	Load lbs.	Strain %	Deviator Stress ksf	Minor Princ. Stress ksf	Major Princ. Stress ksf	1:3 Ratio	P ksf	Q ksf
0	0.0000	0.0	0.0	0.0	0.00	4.32	4.32	1.00		4.32
1	0.0100	74.0	53.3	0.2	1.20	4.32	5.52	1.28		4.92
2	0.0200	107.0	77.0	0.3	1.73	4.32	6.05	1.40		5.19
3	0.0300	132.0	95.0	0.5	2.13	4.32	6.45	1.49		5.39
4	0.0400	151.0	108.7	0.7	2.44	4.32	6.76	1.56		5.54
5	0.0500	167.0	120.2	0.8	2.69	4.32	7.01	1.62		5.67
6	0.0600	184.0	132.5	1.0	2.96	4.32	7.28	1.69		5.80
7	0.0700	197.0	141.8	1.2	3.16	4.32	7.48	1.73		5.90
8	0.0800	211.0	151.9	1.3	3.38	4.32	7.70	1.78		6.01
9	0.0900	222.0	159.8	1.5	3.55	4.32	7.87	1.82		6.10
10	0.1000	232.0	167.0	1.7	3.71	4.32	8.03	1.86		6.17
11	0.2000	283.0	203.8	3.3	4.45	4.32	8.77	2.03		6.54
12	0.3000	312.0	224.6	5.0	4.82	4.32	9.14	2.12		6.73
13	0.4000	330.0	237.6	6.6	5.01	4.32	9.33	2.16		6.82
14	0.5000	346.0	249.1	8.3	5.16	4.32	9.48	2.19		6.90
15	0.6000	355.0	255.6	9.9	5.20	4.32	9.52	2.20		6.92
16	0.7000	371.0	267.1	11.6	5.33	4.32	9.65	2.23		6.99
17	0.8000	377.0	271.4	13.2	5.32	4.32	9.64	2.23		6.98
18	0.9000	389.0	280.1	14.9	5.38	4.32	9.70	2.25		7.01
19	1.0000	404.0	290.9	16.5	5.48	4.32	9.80	2.27		7.06
20	1.1000	403.0	290.2	18.2	5.36	4.32	9.68	2.24		7.00
21	1.2000	402.0	289.4	19.8	5.24	4.32	9.56	2.21		6.94

Specimen Parameter	Initial	Saturated	Final
Moisture content: Moist soil+tare, gms.	1183.800		682.010
Moisture content: Dry soil+tare, gms.	882.000		507.430
Moisture content: Tare, gms.	0.000		13.630
Moisture, %	34.2	34.2	35.4
Moist specimen weight, gms.	1183.8		
Diameter, in.	2.85	2.85	
Area, in. <sup>2</sup>	6.36	6.36	
Height, in.	6.09	6.09	
Net decrease in height, in.		0.00	
Wet Density, pcf	116.5	116.4	
Dry density, pcf	86.8	86.8	
Void ratio	0.9067	0.9067	
Saturation, %	100.0	100.0	

Test Readings for Specimen No. 3

Load ring constant = 0.72 lbs. per input unit

Cell pressure = 90.00 psi (12.96 ksf)

Back pressure = 30.00 psi (4.32 ksf)

Effective confining stress = 8.64 ksf

Strain rate, in./min. = 0.02

Fail. Stress = 3.19 ksf at reading no. 12

No.	Def. Dial in.	Load Dial	Load lbs.	Strain %	Deviator Stress ksf	Minor Princ. Stress ksf	Major Princ. Stress ksf	1:3 Ratio	P ksf	Q ksf
0	0.0000	0.0	0.0	0.0	0.00	8.64	8.64	1.00		8.64
1	0.0100	38.0	27.4	0.2	0.62	8.64	9.26	1.07		8.95
2	0.0200	59.0	42.5	0.3	0.96	8.64	9.60	1.11		9.12
3	0.0300	69.0	49.7	0.5	1.12	8.64	9.76	1.13		9.20
4	0.0400	82.0	59.0	0.7	1.33	8.64	9.97	1.15		9.30
5	0.0500	90.0	64.8	0.8	1.46	8.64	10.10	1.17		9.37
6	0.0600	100.0	72.0	1.0	1.61	8.64	10.25	1.19		9.45
7	0.0700	109.0	78.5	1.1	1.76	8.64	10.40	1.20		9.52
8	0.0800	118.0	85.0	1.3	1.90	8.64	10.54	1.22		9.59
9	0.0900	127.0	91.4	1.5	2.04	8.64	10.68	1.24		9.66
10	0.1000	136.0	97.9	1.6	2.18	8.64	10.82	1.25		9.73
11	0.2000	201.0	144.7	3.3	3.17	8.64	11.81	1.37		10.23
12	0.3000	206.0	148.3	4.9	3.19	8.64	11.83	1.37		10.24
13	0.4000	194.0	139.7	6.6	2.96	8.64	11.60	1.34		10.12
14	0.5000	197.0	141.8	8.2	2.95	8.64	11.59	1.34		10.11
15	0.6000	202.0	145.4	9.8	2.97	8.64	11.61	1.34		10.13
16	0.7000	204.0	146.9	11.5	2.94	8.64	11.58	1.34		10.11
17	0.8000	215.0	154.8	13.1	3.05	8.64	11.69	1.35		10.16
18	0.9000	220.0	158.4	14.8	3.06	8.64	11.70	1.35		10.17
19	1.0000	226.0	162.7	16.4	3.08	8.64	11.72	1.36		10.18
20	1.1000	228.0	164.2	18.1	3.05	8.64	11.69	1.35		10.16
21	1.2000	236.0	169.9	19.7	3.09	8.64	11.73	1.36		10.19

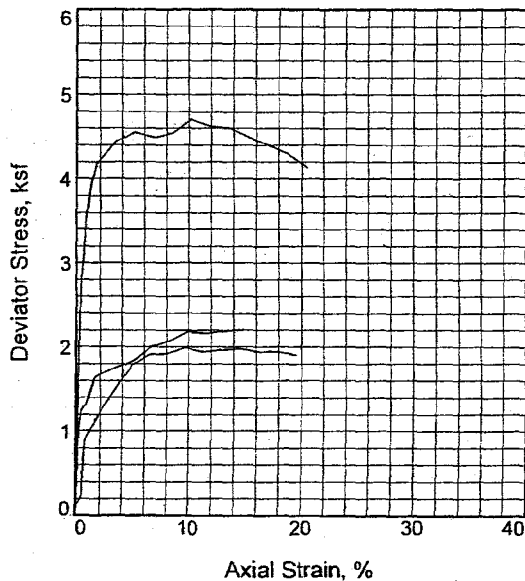
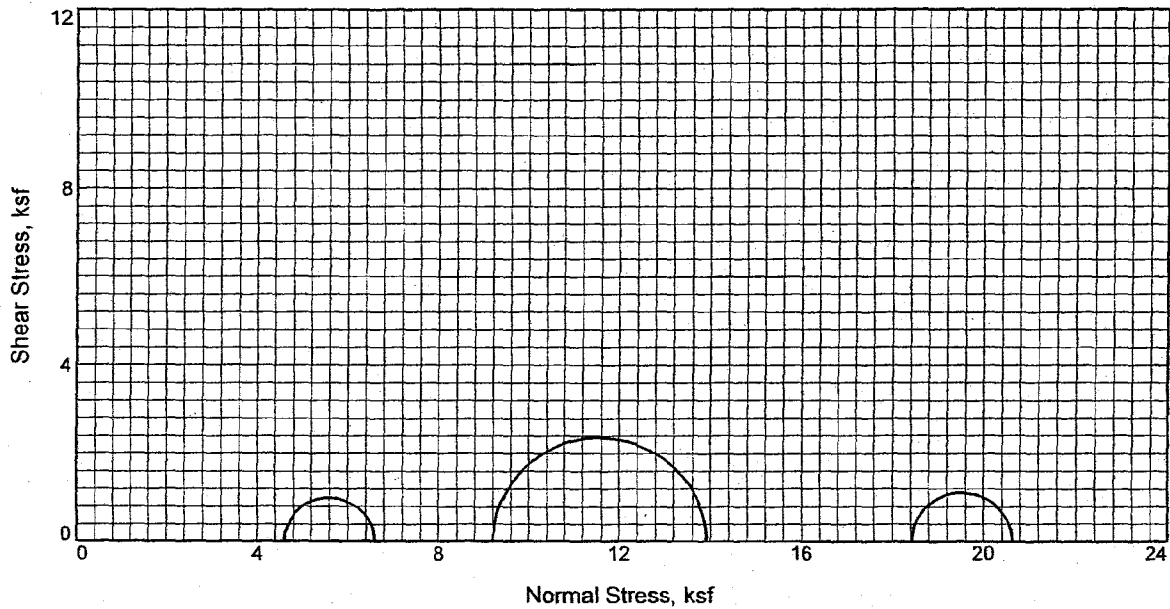

Sample No.		1	2	3
Initial	Water Content,	42.2	23.4	39.4
	Dry Density, pcf	79.2	89.9	79.6
	Saturation,	100.0	71.5	94.4
	Void Ratio	1.1530	0.8947	1.1398
	Diameter, in.	2.84	2.98	2.82
	Height, in.	6.15	5.84	6.01
At Test	Water Content,	42.2	32.8	41.8
	Dry Density, pcf	79.2	89.9	79.6
	Saturation,	100.0	100.0	100.0
	Void Ratio	1.1530	0.8947	1.1398
	Diameter, in.	2.84	2.98	2.82
	Height, in.	6.15	5.84	6.01
Strain rate, in./min.		0.02	0.02	0.02
Back Pressure, ksf		2.9	2.9	2.9
Cell Pressure, ksf		7.5	12.1	21.3
Fail. Stress, ksf		2.0	4.7	2.2
Ult. Stress, ksf				
$\sigma_1$ Failure, ksf		6.6	13.9	20.6
$\sigma_3$ Failure, ksf		4.6	9.2	18.4

**Type of Test:**  
Unconsolidated Undrained  
**Sample Type:** undisturbed  
**Description:**

**Assumed Specific Gravity=** 2.73  
**Remarks:**

**Client:** TVA  
**Project:** TVA Kingston - Proposed Gypsum Stack  
**Location:** NB-44  
**Sample Number:** UD-3,4 & 5 (UU)      **Depth:** 19'-28.5'  
**Proj. No.:** 3043051021      **Date:**

TRIAXIAL SHEAR TEST REPORT  
**MACTEC, INC.**

**Figure** \_\_\_\_\_

**Tested By:** Alexander \_\_\_\_\_ **Checked By:** Hamlett \_\_\_\_\_

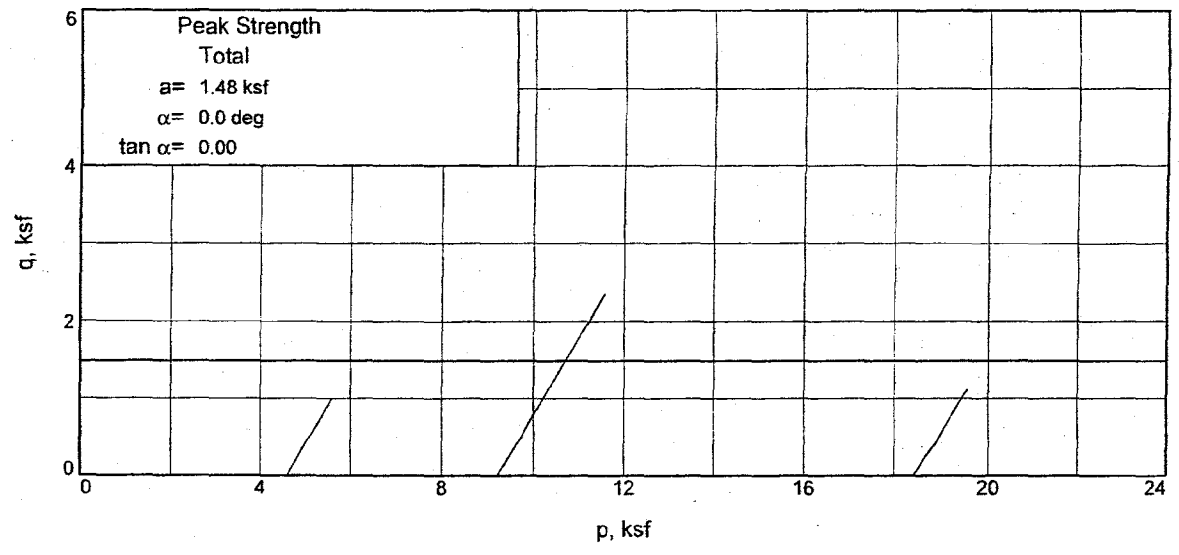
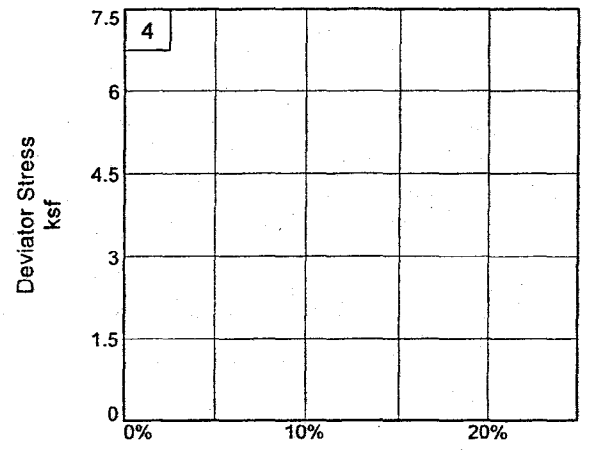
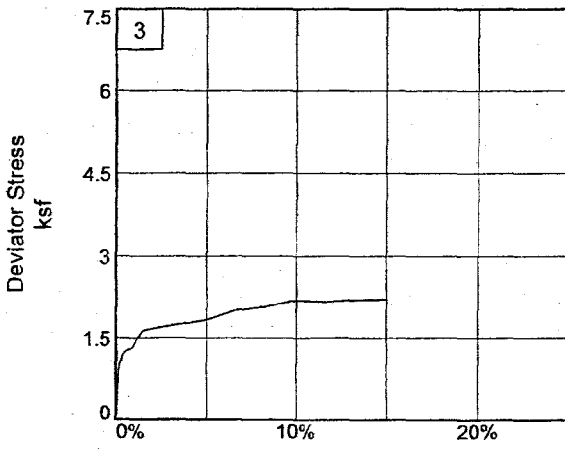
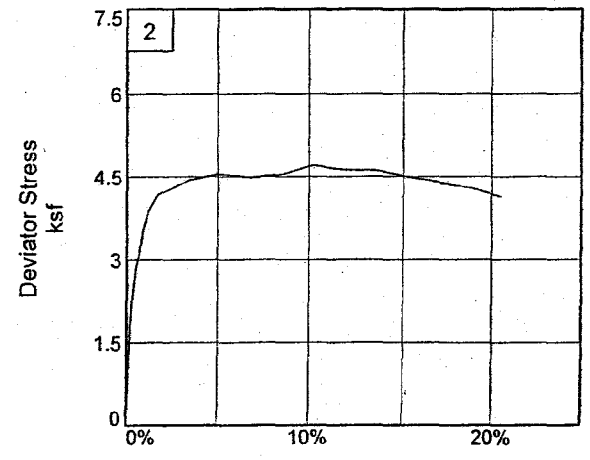
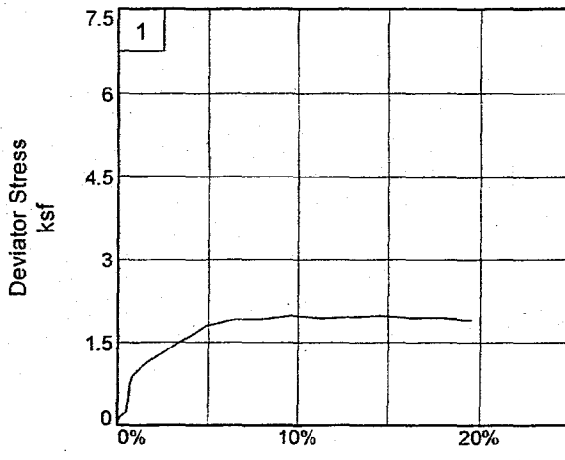

Client: TVA

Project: TVA Kingston - Proposed Gypsum Stack

Location: NB-44

Depth: 19'-28.5'

Sample Number: UD-3,4 & 5 (UU)

Project No.: 3043051021

Figure \_\_\_\_\_

**MACTEC, INC.**

Tested By: Alexander \_\_\_\_\_

Checked By: Hamlett \_\_\_\_\_

**TRIAxIAL COMPRESSION TEST**

Unconsolidated Undrained

9/13/2005

6:44 PM

**Date:**  
**Client:** TVA  
**Project:** TVA Kingston - Proposed Gypsum Stack  
**Project No.:** 3043051021  
**Location:** NB-44  
**Depth:** 19'-28.5' **Sample Number:** UD-3,4 & 5 (UU)  
**Description:**  
**Remarks:**  
**Type of Sample:** undisturbed  
**Specific Gravity:** 2.73 **LL=** **PL=** **PI=**  
**Test Method:** COE uniform strain

**Parameters for Specimen No. 1**

Specimen Parameter	Initial	Saturated	Final
Moisture content: Moist soil+tare, gms.	1142.890		556.460
Moisture content: Dry soil+tare, gms.	803.600		391.870
Moisture content: Tare, gms.	0.000		14.060
Moisture, %	42.2	42.2	43.6
Moist specimen weight, gms.	1154.0		
Diameter, in.	2.84	2.84	
Area, in. <sup>2</sup>	6.35	6.35	
Height, in.	6.15	6.15	
Net decrease in height, in.		0.00	
Wet Density, pcf	112.6	112.6	
Dry density, pcf	79.2	79.2	
Void ratio	1.1530	1.1530	
Saturation, %	100.0	100.0	

**Test Readings for Specimen No. 1**

Load ring constant = 0.72 lbs. per input unit  
 Cell pressure = 52.00 psi (7.49 ksf)  
 Back pressure = 20.00 psi (2.88 ksf)  
 Effective confining stress = 4.61 ksf  
 Strain rate, in./min. = 0.02  
 Fail. Stress = 1.99 ksf at reading no. 15

Test Readings for Specimen No. 1

No.	Def. Dial in.	Load Dial	Load lbs.	Strain %	Deviator Stress ksf	Minor Princ. Stress ksf	Major Princ. Stress ksf	1:3 Ratio	P ksf	Q ksf
0	0.0000	0.0	0.0	0.0	0.00	4.61	4.61	1.00		4.61
1	0.0100	9.0	6.5	0.2	0.15	4.61	4.75	1.03		4.68
2	0.0200	12.0	8.6	0.3	0.20	4.61	4.80	1.04		4.71
3	0.0300	14.0	10.1	0.5	0.23	4.61	4.84	1.05		4.72
4	0.0400	45.0	32.4	0.7	0.73	4.61	5.34	1.16		4.97
5	0.0500	56.0	40.3	0.8	0.91	4.61	5.51	1.20		5.06
6	0.0600	59.0	42.5	1.0	0.95	4.61	5.56	1.21		5.08
7	0.0700	62.0	44.6	1.1	1.00	4.61	5.61	1.22		5.11
8	0.0800	65.0	46.8	1.3	1.05	4.61	5.66	1.23		5.13
9	0.0900	68.0	49.0	1.5	1.09	4.61	5.70	1.24		5.15
10	0.1000	71.0	51.1	1.6	1.14	4.61	5.75	1.25		5.18
11	0.2000	93.0	67.0	3.3	1.47	4.61	6.08	1.32		5.34
12	0.3000	115.0	82.8	4.9	1.79	4.61	6.39	1.39		5.50
13	0.4000	125.0	90.0	6.5	1.91	4.61	6.52	1.41		5.56
14	0.5000	128.0	92.2	8.1	1.92	4.61	6.53	1.42		5.57
15	0.6000	135.0	97.2	9.8	1.99	4.61	6.60	1.43		5.60
16	0.7000	134.0	96.5	11.4	1.94	4.61	6.55	1.42		5.58
17	0.8000	138.0	99.4	13.0	1.96	4.61	6.57	1.43		5.59
18	0.9000	142.0	102.2	14.6	1.98	4.61	6.59	1.43		5.60
19	1.0000	142.0	102.2	16.3	1.94	4.61	6.55	1.42		5.58
20	1.1000	145.0	104.4	17.9	1.94	4.61	6.55	1.42		5.58
21	1.2000	145.0	104.4	19.5	1.90	4.61	6.51	1.41		5.56

MACTEC, INC.



**Parameters for Specimen No. 2**

Specimen Parameter	Initial	Saturated	Final
Moisture content: Moist soil+tare, gms.	1136.380		604.190
Moisture content: Dry soil+tare, gms.	920.700		472.980
Moisture content: Tare, gms.	0.000		14.100
Moisture, %	23.4	32.8	28.6
Moist specimen weight, gms.	1184.0		
Diameter, in.	2.98	2.98	
Area, in. <sup>2</sup>	6.96	6.96	
Height, in.	5.84	5.84	
Net decrease in height, in.		0.00	
Wet Density, pcf	111.0	119.4	
Dry density, pcf	89.9	89.9	
Void ratio	0.8947	0.8947	
Saturation, %	71.5	100.0	

**Test Readings for Specimen No. 2**

Load ring constant = 0.72 lbs. per input unit  
 Cell pressure = 84.00 psi (12.10 ksf)  
 Back pressure = 20.00 psi (2.88 ksf)  
 Effective confining stress = 9.22 ksf  
 Strain rate, in./min. = 0.02  
 Fail. Stress = 4.71 ksf at reading no. 14

No.	Def. Dial in.	Load Dial	Load lbs.	Strain %	Deviator Stress ksf	Minor Princ. Stress ksf	Major Princ. Stress ksf	1:3 Ratio	P ksf	Q ksf
0	0.0000	0.0	0.0	0.0	0.00	9.22	9.22	1.00		9.22
1	0.0100	109.0	78.5	0.2	1.62	9.22	10.84	1.18		10.03
2	0.0200	161.0	115.9	0.3	2.39	9.22	11.61	1.26		10.41
3	0.0300	193.0	139.0	0.5	2.86	9.22	12.08	1.31		10.65
4	0.0400	207.0	149.0	0.7	3.06	9.22	12.28	1.33		10.75
5	0.0500	236.0	169.9	0.9	3.49	9.22	12.70	1.38		10.96
6	0.0700	263.0	189.4	1.2	3.87	9.22	13.09	1.42		11.15
7	0.0800	271.0	195.1	1.4	3.98	9.22	13.20	1.43		11.21
8	0.0900	278.0	200.2	1.5	4.08	9.22	13.30	1.44		11.26
9	0.1000	285.0	205.2	1.7	4.18	9.22	13.39	1.45		11.30
10	0.2000	308.0	221.8	3.4	4.43	9.22	13.65	1.48		11.43
11	0.3000	322.0	231.8	5.1	4.55	9.22	13.77	1.49		11.49
12	0.4000	323.0	232.6	6.8	4.48	9.22	13.70	1.49		11.46
13	0.5000	333.0	239.8	8.6	4.54	9.22	13.75	1.49		11.49
14	0.6000	352.0	253.4	10.3	4.71	9.22	13.92	1.51		11.57
15	0.7000	352.0	253.4	12.0	4.62	9.22	13.83	1.50		11.52
16	0.8000	358.0	257.8	13.7	4.61	9.22	13.82	1.50		11.52
17	0.9000	356.0	256.3	15.4	4.49	9.22	13.70	1.49		11.46
18	1.0000	356.0	256.3	17.1	4.40	9.22	13.61	1.48		11.41
19	1.1000	355.0	255.6	18.8	4.29	9.22	13.51	1.47		11.36
20	1.2000	349.0	251.3	20.5	4.13	9.22	13.35	1.45		11.28

**Parameters for Specimen No. 3**

Specimen Parameter	Initial	Saturated	Final
Moisture content: Moist soil+tare, gms.	1096.380		503.560
Moisture content: Dry soil+tare, gms.	786.500		365.160
Moisture content: Tare, gms.	0.000		8.120
Moisture, %	39.4	41.8	38.8
Moist specimen weight, gms.	1091.7		
Diameter, in.	2.82	2.82	
Area, in. <sup>2</sup>	6.24	6.24	
Height, in.	6.01	6.01	
Net decrease in height, in.		0.00	
Wet Density, pcf	111.0	112.9	
Dry density, pcf	79.6	79.6	
Void ratio	1.1398	1.1398	
Saturation, %	94.4	100.0	

**Test Readings for Specimen No. 3**

Load ring constant = 0.72 lbs. per input unit  
 Cell pressure = 148.00 psi (21.31 ksf)  
 Back pressure = 20.00 psi (2.88 ksf)  
 Effective confining stress = 18.43 ksf  
 Strain rate, in./min. = 0.02  
 Fail. Stress = 2.20 ksf at reading no. 17

No.	Def. Dial in.	Load Dial	Load lbs.	Strain %	Deviator Stress ksf	Minor Princ. Stress ksf	Major Princ. Stress ksf	1:3 Ratio	P ksf	Q ksf
0	0.0000	0.0	0.0	0.0	0.00	18.43	18.43	1.00		18.43
1	0.0100	56.0	40.3	0.2	0.93	18.43	19.36	1.05		18.90
2	0.0200	71.0	51.1	0.3	1.18	18.43	19.61	1.06		19.02
3	0.0300	76.0	54.7	0.5	1.26	18.43	19.69	1.07		19.06
4	0.0400	78.0	56.2	0.7	1.29	18.43	19.72	1.07		19.08
5	0.0500	79.0	56.9	0.8	1.30	18.43	19.73	1.07		19.08
6	0.0600	84.0	60.5	1.0	1.38	18.43	19.81	1.08		19.12
7	0.0700	90.0	64.8	1.2	1.48	18.43	19.91	1.08		19.17
8	0.0800	94.0	67.7	1.3	1.54	18.43	19.97	1.08		19.20
9	0.0900	99.0	71.3	1.5	1.62	18.43	20.05	1.09		19.24
10	0.1000	101.0	72.7	1.7	1.65	18.43	20.08	1.09		19.26
11	0.3000	116.0	83.5	5.0	1.83	18.43	20.26	1.10		19.35
12	0.4000	129.0	92.9	6.7	2.00	18.43	20.43	1.11		19.43
13	0.5000	136.0	97.9	8.3	2.07	18.43	20.50	1.11		19.47
14	0.6000	146.0	105.1	10.0	2.18	18.43	20.62	1.12		19.52
15	0.7000	147.0	105.8	11.7	2.16	18.43	20.59	1.12		19.51
16	0.8000	152.0	109.4	13.3	2.19	18.43	20.62	1.12		19.53
17	0.9000	156.0	112.3	15.0	2.20	18.43	20.64	1.12		19.53

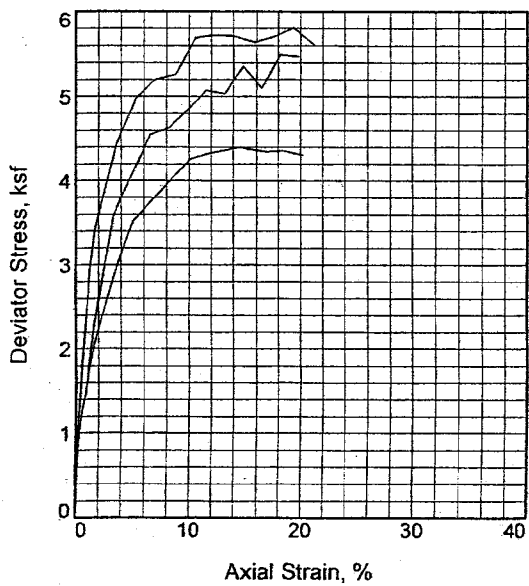
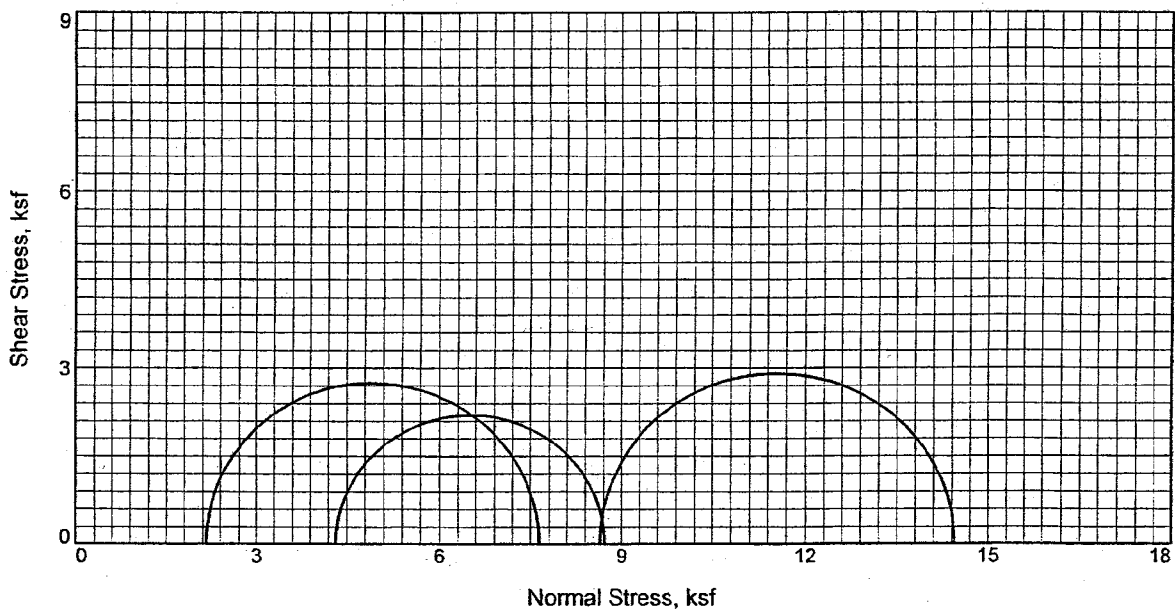

Sample No.	1	2	3	
Initial	Water Content,	25.4	25.6	20.5
	Dry Density, pcf	97.3	99.4	100.9
	Saturation,	92.8	98.3	81.8
	Void Ratio	0.7445	0.7080	0.6830
	Diameter, in.	2.88	2.83	2.79
	Height, in.	6.05	5.93	5.67
At Test	Water Content,	27.4	26.0	25.1
	Dry Density, pcf	97.3	99.4	100.9
	Saturation,	100.0	100.0	100.0
	Void Ratio	0.7445	0.7080	0.6830
	Diameter, in.	2.88	2.83	2.79
	Height, in.	6.05	5.93	5.67
Strain rate, in./min.	0.02	0.02	0.02	
Back Pressure, ksf	5.8	5.8	5.8	
Cell Pressure, ksf	7.9	10.1	14.4	
Fail. Stress, ksf	5.5	4.4	5.8	
Ult. Stress, ksf				
$\sigma_1$ Failure, ksf	7.6	8.7	14.4	
$\sigma_3$ Failure, ksf	2.2	4.3	8.6	

**Type of Test:**  
Unconsolidated Undrained

**Sample Type:** undisturbed

**Description:**

**Assumed Specific Gravity=** 2.72

**Remarks:**

**Client:** TVA

**Project:** TVA Kingston - Proposed Gypsum Stack

**Location:** NB-47A

**Sample Number:** UD-1, 2 & 3 (UU)

**Depth:** 9'-17'

**Proj. No.:** 3043051021

**Date:**

TRIAXIAL SHEAR TEST REPORT

**MACTEC, INC.**

**Figure** \_\_\_\_\_

**Tested By:** Alexander \_\_\_\_\_

**Checked By:** Hamlett \_\_\_\_\_

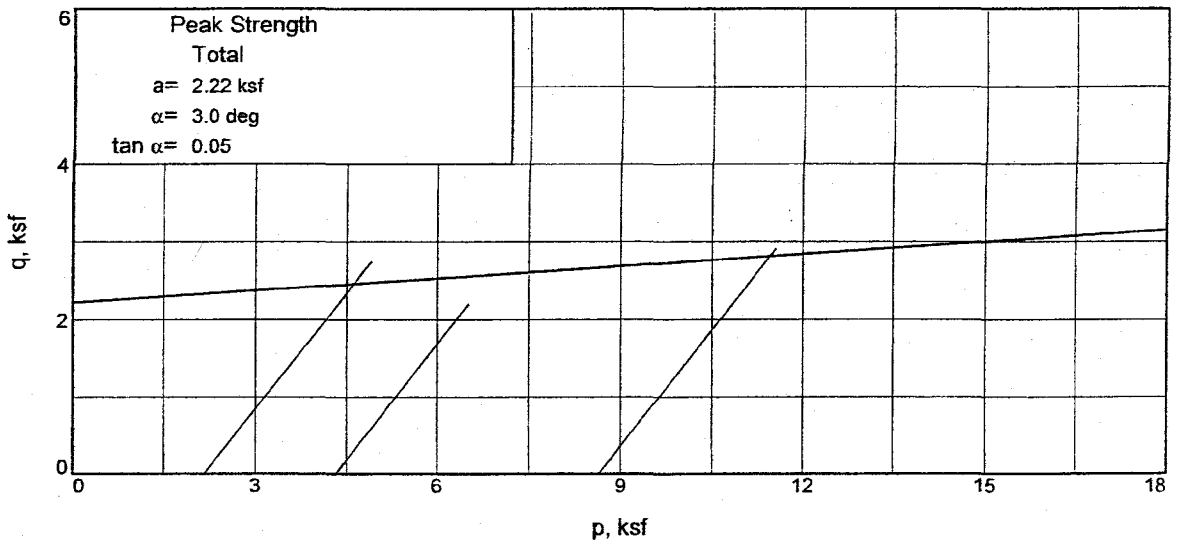
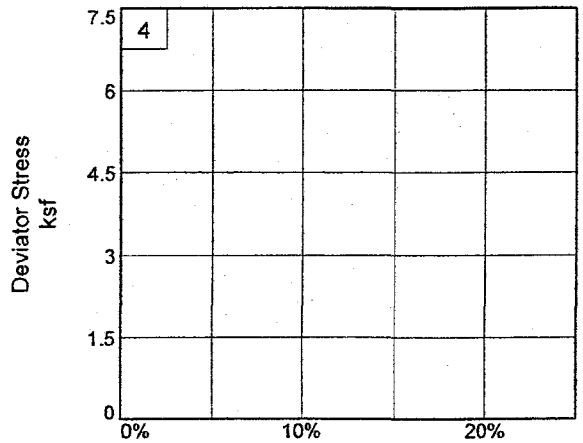
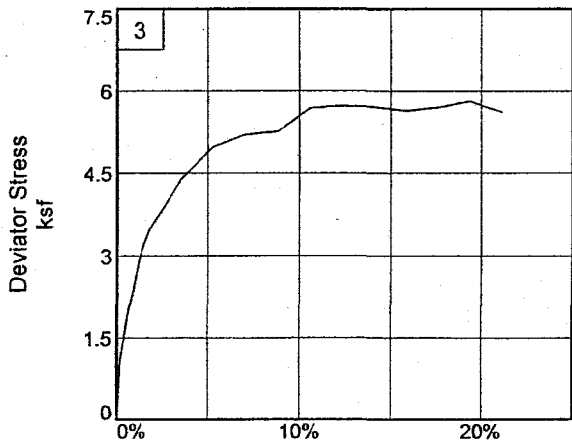
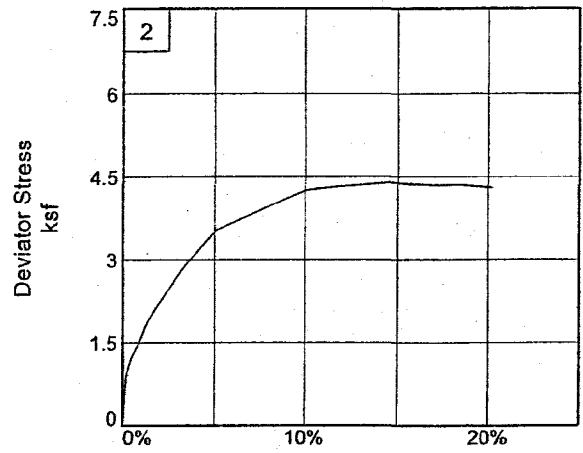
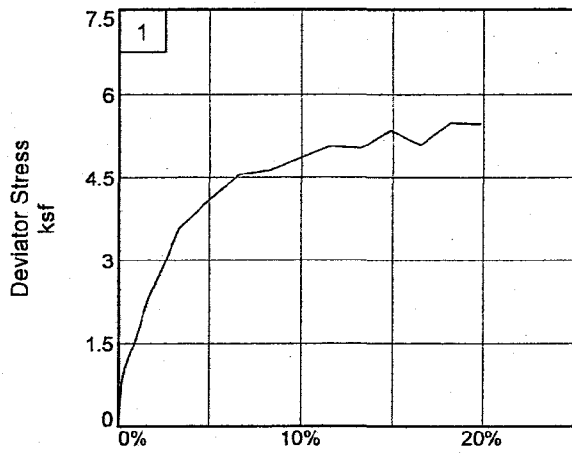

Client: TVA

Project: TVA Kingston - Proposed Gypsum Stack

Location: NB-47A

Depth: 9'-17'

Sample Number: UD-1, 2 & 3 (UU)

Project No.: 3043051021

Figure \_\_\_\_\_

**MACTEC, INC.**

Tested By: Alexander

Checked By: Hamlett

**TRIAxIAL COMPRESSION TEST**

Unconsolidated Undrained

9/13/2005

6:55 PM

Date:  
 Client: TVA  
 Project: TVA Kingston - Proposed Gypsum Stack  
 Project No.: 3043051021  
 Location: NB-47A  
 Depth: 9'-17' Sample Number: UD-1, 2 & 3 (UU)  
 Description:  
 Remarks:  
 Type of Sample: undisturbed  
 Specific Gravity=2.72 LL= PL= PI=  
 Test Method: COE uniform strain

**Parameters for Specimen No. 1**

Specimen Parameter	Initial	Saturated	Final
Moisture content: Moist soil+tare, gms.	1235.900		649.520
Moisture content: Dry soil+tare, gms.	985.650		511.890
Moisture content: Tare, gms.	0.000		14.190
Moisture, %	25.4	27.4	27.7
Moist specimen weight, gms.	1258.7		
Diameter, in.	2.88	2.88	
Area, in. <sup>2</sup>	6.49	6.49	
Height, in.	6.05	6.05	
Net decrease in height, in.		0.00	
Wet Density, pcf	122.0	124.0	
Dry density, pcf	97.3	97.3	
Void ratio	0.7445	0.7445	
Saturation, %	92.8	100.0	

**Test Results for Specimen No. 1**

Load ring constant = 0.72 lbs. per input unit  
 Cell pressure = 55.00 psi (7.92 ksf)  
 Back pressure = 40.00 psi (5.76 ksf)  
 Effective confining stress = 2.16 ksf  
 Strain rate, in./min. = 0.02  
 Fail. Stress = 5.49 ksf at reading no. 20

No.	Def. Dial in.	Load Dial	Load lbs.	Strain %	Deviator Stress ksf	Minor Princ. Stress ksf	Major Princ. Stress ksf	1:3 Ratio	P ksf	Q ksf
0	0.0000	0.0	0.0	0.0	0.00	2.16	2.16	1.00		2.16
1	0.0100	48.0	34.6	0.2	0.77	2.16	2.93	1.35		2.54
2	0.0200	65.0	46.8	0.3	1.03	2.16	3.19	1.48		2.68
3	0.0300	75.0	54.0	0.5	1.19	2.16	3.35	1.55		2.76
4	0.0400	85.0	61.2	0.7	1.35	2.16	3.51	1.62		2.83
5	0.0500	92.0	66.2	0.8	1.46	2.16	3.62	1.67		2.89
6	0.0600	103.0	74.2	1.0	1.63	2.16	3.79	1.75		2.97
7	0.0700	114.0	82.1	1.2	1.80	2.16	3.96	1.83		3.06
8	0.0800	126.0	90.7	1.3	1.99	2.16	4.15	1.92		3.15
9	0.0900	137.0	98.6	1.5	2.16	2.16	4.32	2.00		3.24
10	0.1000	147.0	105.8	1.7	2.31	2.16	4.47	2.07		3.31
11	0.2000	232.0	167.0	3.3	3.58	2.16	5.74	2.66		3.95
12	0.3000	269.0	193.7	5.0	4.08	2.16	6.24	2.89		4.20
13	0.4000	305.0	219.6	6.6	4.55	2.16	6.71	3.11		4.43
14	0.5000	316.0	227.5	8.3	4.63	2.16	6.79	3.14		4.47
15	0.6000	337.0	242.6	9.9	4.85	2.16	7.01	3.24		4.58
16	0.7000	359.0	258.5	11.6	5.07	2.16	7.23	3.35		4.70
17	0.8000	363.0	261.4	13.2	5.03	2.16	7.19	3.33		4.68
18	0.9000	394.0	283.7	14.9	5.36	2.16	7.52	3.48		4.84
19	1.0000	382.0	275.0	16.5	5.09	2.16	7.25	3.36		4.71
20	1.1000	420.0	302.4	18.2	5.49	2.16	7.65	3.54		4.90
21	1.2000	427.0	307.4	19.8	5.47	2.16	7.63	3.53		4.89

MACTEC, INC.

Specimen Parameter	Initial	Saturated	Final
Moisture content: Moist soil+tare, gms.	1182.300		674.310
Moisture content: Dry soil+tare, gms.	941.500		523.170
Moisture content: Tare, gms.	0.000		14.380
Moisture, %	25.6	26.0	29.7
Moist specimen weight, gms.	1221.1		
Diameter, in.	2.83	2.83	
Area, in. <sup>2</sup>	6.29	6.29	
Height, in.	5.93	5.93	
Net decrease in height, in.		0.00	
Wet Density, pcf	124.8	125.3	
Dry density, pcf	99.4	99.4	
Void ratio	0.7080	0.7080	
Saturation, %	98.3	100.0	

**Test Readings for Specimen No. 2**

Load ring constant = 0.72 lbs. per input unit

Cell pressure = 70.00 psi (10.08 ksf)

Back pressure = 40.00 psi (5.76 ksf)

Effective confining stress = 4.32 ksf

Strain rate, in./min. = 0.02

Fail. Stress = 4.40 ksf at reading no. 17

No.	Def. Dial in.	Load Dial	Load lbs.	Strain %	Deviator Stress ksf	Minor Princ. Stress ksf	Major Princ. Stress ksf	1:3 Ratio	P ksf	Q ksf
0	0.0000	0.0	0.0	0.0	0.00	4.32	4.32	1.00		4.32
1	0.0100	53.0	38.2	0.2	0.87	4.32	5.19	1.20		4.76
2	0.0200	66.0	47.5	0.3	1.08	4.32	5.40	1.25		4.86
3	0.0300	76.0	54.7	0.5	1.25	4.32	5.57	1.29		4.94
4	0.0400	83.0	59.8	0.7	1.36	4.32	5.68	1.31		5.00
5	0.0500	90.0	64.8	0.8	1.47	4.32	5.79	1.34		5.06
6	0.0600	98.0	70.6	1.0	1.60	4.32	5.92	1.37		5.12
7	0.0700	107.0	77.0	1.2	1.74	4.32	6.06	1.40		5.19
8	0.0800	115.0	82.8	1.3	1.87	4.32	6.19	1.43		5.26
9	0.0900	121.0	87.1	1.5	1.97	4.32	6.29	1.45		5.30
10	0.1000	128.0	92.2	1.7	2.08	4.32	6.40	1.48		5.36
11	0.2000	181.0	130.3	3.4	2.88	4.32	7.20	1.67		5.76
12	0.3000	225.0	162.0	5.1	3.52	4.32	7.84	1.82		6.08
13	0.4000	245.0	176.4	6.7	3.77	4.32	8.09	1.87		6.20
14	0.5000	266.0	191.5	8.4	4.02	4.32	8.34	1.93		6.33
15	0.6000	287.0	206.6	10.1	4.25	4.32	8.57	1.98		6.45
16	0.7000	297.0	213.8	11.8	4.32	4.32	8.64	2.00		6.48
17	0.8760	313.0	225.4	14.8	4.40	4.32	8.72	2.02		6.52
18	0.9000	313.0	225.4	15.2	4.38	4.32	8.70	2.01		6.51
19	1.0000	317.0	228.2	16.9	4.35	4.32	8.67	2.01		6.49
20	1.1000	324.0	233.3	18.6	4.35	4.32	8.67	2.01		6.50
21	1.2000	327.0	235.4	20.2	4.30	4.32	8.62	2.00		6.47

Specimen Parameter	Initial	Saturated	Final
Moisture content: Moist soil+tare, gms.	1054.000		558.820
Moisture content: Dry soil+tare, gms.	874.400		444.260
Moisture content: Tare, gms.	0.000		14.300
Moisture, %	20.5	25.1	26.6
Moist specimen weight, gms.	1107.0		
Diameter, in.	2.79	2.79	
Area, in. <sup>2</sup>	6.11	6.11	
Height, in.	5.67	5.67	
Net decrease in height, in.		0.00	
Wet Density, pcf	121.6	126.2	
Dry density, pcf	100.9	100.9	
Void ratio	0.6830	0.6830	
Saturation, %	81.8	100.0	

Load ring constant = 0.72 lbs. per input unit

Cell pressure = 100.00 psi (14.40 ksf)

Back pressure = 40.00 psi (5.76 ksf)

Effective confining stress = 8.64 ksf

Strain rate, in./min. = 0.02

Fail. Stress = 5.81 ksf at reading no. 20

No.	Def. Dial in.	Load Dial	Load lbs.	Strain %	Deviator Stress ksf	Minor Princ. Stress ksf	Major Princ. Stress ksf	1:3 Ratio	P ksf	Q ksf
0	0.0000	0.0	0.0	0.0	0.00	8.64	8.64	1.00		8.64
1	0.0100	63.0	45.4	0.2	1.07	8.64	9.71	1.12		9.17
2	0.0200	85.0	61.2	0.4	1.44	8.64	10.08	1.17		9.36
3	0.0300	107.0	77.0	0.5	1.81	8.64	10.45	1.21		9.54
4	0.0400	126.0	90.7	0.7	2.12	8.64	10.76	1.25		9.70
5	0.0500	140.0	100.8	0.9	2.35	8.64	10.99	1.27		9.82
6	0.0600	158.0	113.8	1.1	2.65	8.64	11.29	1.31		9.97
7	0.0700	175.0	126.0	1.2	2.93	8.64	11.57	1.34		10.11
8	0.0800	188.0	135.4	1.4	3.14	8.64	11.78	1.36		10.21
9	0.0900	198.0	142.6	1.6	3.30	8.64	11.94	1.38		10.29
10	0.1000	208.0	149.8	1.8	3.47	8.64	12.11	1.40		10.37
11	0.2000	269.0	193.7	3.5	4.40	8.64	13.04	1.51		10.84
12	0.3000	310.0	223.2	5.3	4.98	8.64	13.62	1.58		11.13
13	0.4000	330.0	237.6	7.1	5.20	8.64	13.84	1.60		11.24
14	0.5000	340.0	244.8	8.8	5.26	8.64	13.90	1.61		11.27
15	0.6000	375.0	270.0	10.6	5.69	8.64	14.33	1.66		11.48
16	0.7000	385.0	277.2	12.3	5.72	8.64	14.36	1.66		11.50
17	0.8000	392.0	282.2	14.1	5.71	8.64	14.35	1.66		11.50
18	0.9000	395.0	284.4	15.9	5.64	8.64	14.28	1.65		11.46
19	1.0000	408.0	293.8	17.6	5.70	8.64	14.34	1.66		11.49
20	1.1000	425.0	306.0	19.4	5.81	8.64	14.45	1.67		11.54
21	1.2000	420.0	302.4	21.2	5.62	8.64	14.26	1.65		11.45

MACTEC, INC.

TVA-00021718



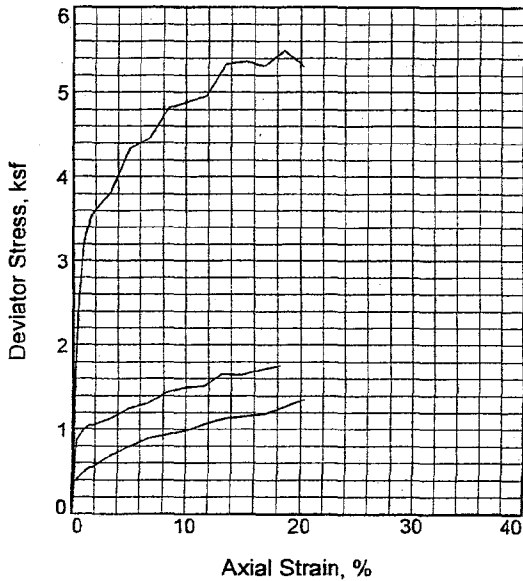
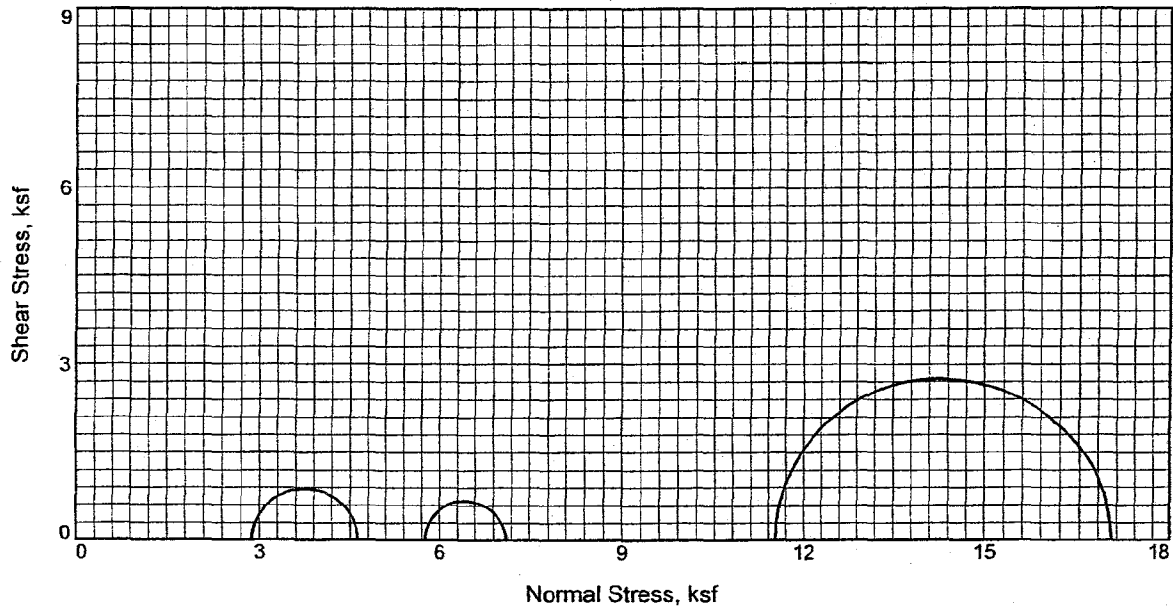

Sample No.	1	2	3	
Initial	Water Content,	25.8	31.3	27.5
	Dry Density, pcf	94.4	87.2	91.7
	Saturation,	87.7	90.0	87.8
	Void Ratio	0.7995	0.9468	0.8508
	Diameter, in.	2.82	2.86	2.83
At Test	Height, in.	6.05	5.90	5.92
	Water Content,	29.4	34.8	31.3
	Dry Density, pcf	94.4	87.2	91.7
	Saturation,	100.0	100.0	100.0
	Void Ratio	0.7995	0.9468	0.8508
Test Parameters	Diameter, in.	2.82	2.86	2.83
	Height, in.	6.05	5.90	5.92
	Strain rate, in./min.	0.02	0.02	0.02
	Back Pressure, ksf	2.9	2.9	2.9
	Cell Pressure, ksf	5.8	8.6	14.4
	Fail. Stress, ksf	1.8	1.4	5.5
	Ult. Stress, ksf			
	$\sigma_1$ Failure, ksf	4.6	7.1	17.0
	$\sigma_3$ Failure, ksf	2.9	5.8	11.5

**Type of Test:**  
Unconsolidated Undrained  
**Sample Type:** undisturbed  
**Description:**

**Assumed Specific Gravity=** 2.72  
**Remarks:**

**Client:** TVA  
**Project:** TVA Kingston - Proposed Gypsum Stack  
**Location:** NB-47A  
**Sample Number:** UD-4, 5 & 6 (UU)      **Depth:** 18'-27'  
**Proj. No.:** 3043051021      **Date:**

TRIAxIAL SHEAR TEST REPORT  
**MACTEC, INC.**

**Tested By:** Alexander \_\_\_\_\_ **Checked By:** Hamlett \_\_\_\_\_

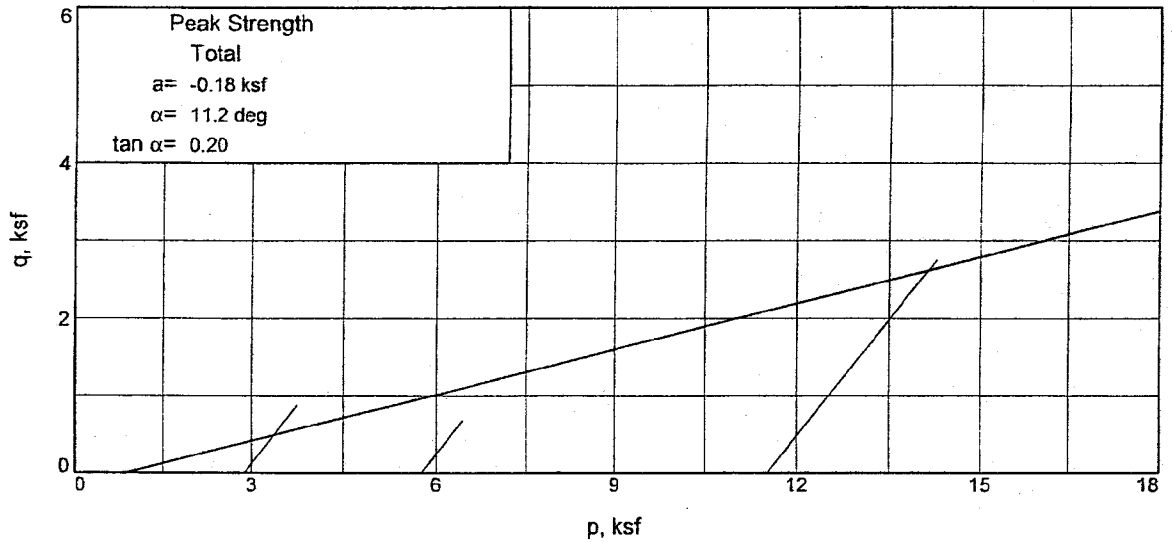
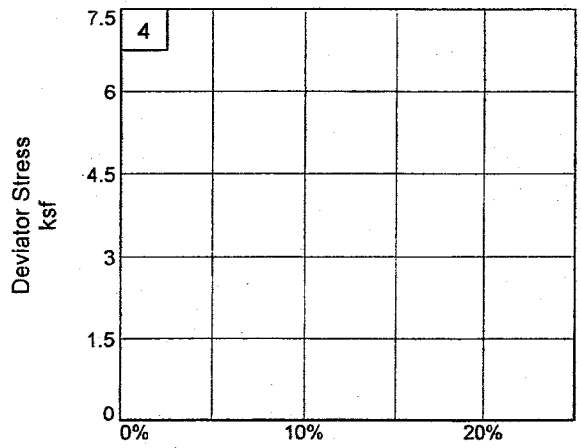
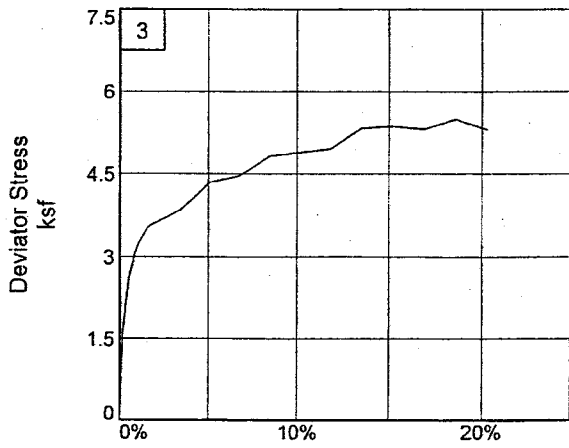
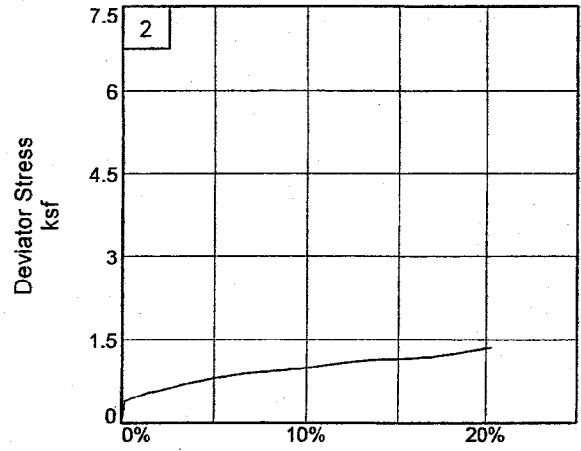
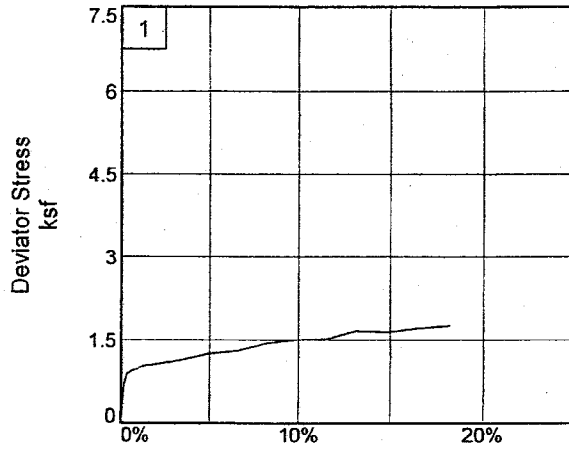

Client: TVA

Project: TVA Kingston - Proposed Gypsum Stack

Location: NB-47A

Depth: 18'-27'

Sample Number: UD-4, 5 & 6 (UU)

Project No.: 3043051021

Figure \_\_\_\_\_

**MACTEC, INC.**

Tested By: Alexander \_\_\_\_\_

Checked By: Hamlett \_\_\_\_\_

**TRIAxIAL COMPRESSION TEST**  
Unconsolidated Undrained

9/13/2005  
7:46 PM

Date:  
 Client: TVA  
 Project: TVA Kingston - Proposed Gypsum Stack  
 Project No.: 3043051021  
 Location: NB-47A  
 Depth: 18'-27' Sample Number: UD-4, 5 & 6 (UU)  
 Description:  
 Remarks:  
 Type of Sample: undisturbed  
 Specific Gravity=2.72 LL=58 PL=34 PI=24  
 Test Method: COE uniform strain

**Parameters for Specimen No. 4**

Specimen Parameter	Initial	Saturated	Final
Moisture content: Moist soil+tare, gms.	1194.000		623.320
Moisture content: Dry soil+tare, gms.	949.200		502.460
Moisture content: Tare, gms.	0.000		14.190
Moisture, %	25.8	29.4	24.8
Moist specimen weight, gms.	1177.9		
Diameter, in.	2.82	2.82	
Area, in. <sup>2</sup>	6.25	6.25	
Height, in.	6.05	6.05	
Net decrease in height, in.		0.00	
Wet Density, pcf	118.7	122.1	
Dry density, pcf	94.4	94.4	
Void ratio	0.7995	0.7995	
Saturation, %	87.7	100.0	

**Test Readings for Specimen No. 4**

Load ring constant = 0.72 lbs. per input unit  
 Cell pressure = 40.00 psi (5.76 ksf)  
 Back pressure = 20.00 psi (2.88 ksf)  
 Effective confining stress = 2.88 ksf  
 Strain rate, in./min. = 0.02  
 Fail. Stress = 1.75 ksf at reading no. 20

Test Readings for Specimen No. 1

No.	Def. Dial in.	Load Dial	Load lbs.	Strain %	Deviator Stress ksf	Minor Princ. Stress ksf	Major Princ. Stress ksf	1:3 Ratio	P ksf	Q ksf
0	0.0000	0.0	0.0	0.0	0.00	2.88	2.88	1.00		2.88
1	0.0100	40.0	28.8	0.2	0.66	2.88	3.54	1.23		3.21
2	0.0200	53.0	38.2	0.3	0.88	2.88	3.76	1.30		3.32
3	0.0300	55.0	39.6	0.5	0.91	2.88	3.79	1.32		3.33
4	0.0400	57.0	41.0	0.7	0.94	2.88	3.82	1.33		3.35
5	0.0500	58.0	41.8	0.8	0.95	2.88	3.83	1.33		3.36
6	0.0600	60.0	43.2	1.0	0.99	2.88	3.87	1.34		3.37
7	0.0700	62.0	44.6	1.2	1.02	2.88	3.90	1.35		3.39
8	0.0800	63.0	45.4	1.3	1.03	2.88	3.91	1.36		3.40
9	0.0900	64.0	46.1	1.5	1.05	2.88	3.93	1.36		3.40
10	0.1000	64.0	46.1	1.7	1.04	2.88	3.92	1.36		3.40
11	0.2000	70.0	50.4	3.3	1.12	2.88	4.00	1.39		3.44
12	0.3000	79.0	56.9	5.0	1.25	2.88	4.13	1.43		3.50
13	0.4000	84.0	60.5	6.6	1.30	2.88	4.18	1.45		3.53
14	0.5000	94.0	67.7	8.3	1.43	2.88	4.31	1.50		3.60
15	0.6000	100.0	72.0	9.9	1.50	2.88	4.38	1.52		3.63
16	0.7000	103.0	74.2	11.6	1.51	2.88	4.39	1.53		3.64
17	0.8000	115.0	82.8	13.2	1.66	2.88	4.54	1.58		3.71
18	0.9000	116.0	83.5	14.9	1.64	2.88	4.52	1.57		3.70
19	1.0000	123.0	88.6	16.5	1.70	2.88	4.58	1.59		3.73
20	1.1000	129.0	92.9	18.2	1.75	2.88	4.63	1.61		3.76

**Parameters for Specimen No. 2**

Specimen Parameter	Initial	Saturated	Final
Moisture content: Moist soil+tare, gms.	1166.800		1151.350
Moisture content: Dry soil+tare, gms.	888.400		897.910
Moisture content: Tare, gms.	0.000		13.610
Moisture, %	31.3	34.8	28.7
Moist specimen weight, gms.	1138.9		
Diameter, in.	2.86	2.86	
Area, in. <sup>2</sup>	6.42	6.42	
Height, in.	5.90	5.90	
Net decrease in height, in.		0.00	
Wet Density, pcf	114.6	117.6	
Dry density, pcf	87.2	87.2	
Void ratio	0.9468	0.9468	
Saturation, %	90.0	100.0	

**Test Readings for Specimen No. 2**

Load ring constant = 0.72 lbs. per input unit

Cell pressure = 60.00 psi (8.64 ksf)

Back pressure = 20.00 psi (2.88 ksf)

Effective confining stress = 5.76 ksf

Strain rate, in./min. = 0.02

Fail. Stress = 1.35 ksf at reading no. 21

No.	Def. Dial in.	Load Dial	Load lbs.	Strain %	Deviator Stress ksf	Minor Princ. Stress ksf	Major Princ. Stress ksf	1:3 Ratio	P ksf	Q ksf
0	0.0000	0.0	0.0	0.0	0.00	5.76	5.76	1.00		5.76
1	0.0100	24.0	17.3	0.2	0.39	5.76	6.15	1.07		5.95
2	0.0200	25.0	18.0	0.3	0.40	5.76	6.16	1.07		5.96
3	0.0300	27.0	19.4	0.5	0.43	5.76	6.19	1.08		5.98
4	0.0400	28.0	20.2	0.7	0.45	5.76	6.21	1.08		5.98
5	0.0500	29.0	20.9	0.8	0.46	5.76	6.22	1.08		5.99
6	0.0600	30.0	21.6	1.0	0.48	5.76	6.24	1.08		6.00
7	0.0700	32.0	23.0	1.2	0.51	5.76	6.27	1.09		6.02
8	0.0800	33.0	23.8	1.4	0.53	5.76	6.29	1.09		6.02
9	0.0900	34.0	24.5	1.5	0.54	5.76	6.30	1.09		6.03
10	0.1000	34.0	24.5	1.7	0.54	5.76	6.30	1.09		6.03
11	0.2000	44.0	31.7	3.4	0.69	5.76	6.45	1.12		6.10
12	0.3000	52.0	37.4	5.1	0.80	5.76	6.56	1.14		6.16
13	0.4000	59.0	42.5	6.8	0.89	5.76	6.65	1.15		6.20
14	0.5000	63.0	45.4	8.5	0.93	5.76	6.69	1.16		6.23
15	0.6000	68.0	49.0	10.2	0.99	5.76	6.75	1.17		6.25
16	0.7000	75.0	54.0	11.9	1.07	5.76	6.83	1.19		6.29
17	0.8000	81.0	58.3	13.6	1.13	5.76	6.89	1.20		6.33
18	0.9000	84.0	60.5	15.2	1.15	5.76	6.91	1.20		6.34
19	1.0000	88.0	63.4	16.9	1.18	5.76	6.94	1.21		6.35
20	1.1000	96.0	69.1	18.6	1.26	5.76	7.02	1.22		6.39
21	1.2000	105.0	75.6	20.3	1.35	5.76	7.11	1.23		6.44

**Parameters for Specimen No. 3**

Specimen Parameter	Initial	Saturated	Final
Moisture content: Moist soil+tare, gms.	1110.000		629.880
Moisture content: Dry soil+tare, gms.	870.900		478.800
Moisture content: Tare, gms.	0.000		13.550
Moisture, %	27.5	31.3	32.5
Moist specimen weight, gms.	1146.1		
Diameter, in.	2.83	2.83	
Area, in. <sup>2</sup>	6.31	6.31	
Height, in.	5.92	5.92	
Net decrease in height, in.		0.00	
Wet Density, pcf	116.9	120.4	
Dry density, pcf	91.7	91.7	
Void ratio	0.8508	0.8508	
Saturation, %	87.8	100.0	

**Test Readings for Specimen No. 3**

Load ring constant = 0.72 lbs. per input unit  
 Cell pressure = 100.00 psi (14.40 ksf)  
 Back pressure = 20.00 psi (2.88 ksf)  
 Effective confining stress = 11.52 ksf  
 Strain rate, in./min. = 0.02  
 Fail. Stress = 5.50 ksf at reading no. 20

No.	Def. Dial in.	Load Dial	Load lbs.	Strain %	Deviator Stress ksf	Minor Princ. Stress ksf	Major Princ. Stress ksf	1:3 Ratio	P ksf	Q ksf
0	0.0000	0.0	0.0	0.0	0.00	11.52	11.52	1.00		11.52
1	0.0100	98.0	70.6	0.2	1.61	11.52	13.13	1.14		12.32
2	0.0200	128.0	92.2	0.3	2.10	11.52	13.62	1.18		12.57
3	0.0300	158.0	113.8	0.5	2.58	11.52	14.10	1.22		12.81
4	0.0400	172.0	123.8	0.7	2.81	11.52	14.33	1.24		12.92
5	0.0500	186.0	133.9	0.8	3.03	11.52	14.55	1.26		13.03
6	0.0600	197.0	141.8	1.0	3.20	11.52	14.72	1.28		13.12
7	0.0700	204.0	146.9	1.2	3.31	11.52	14.83	1.29		13.18
8	0.0800	210.0	151.2	1.4	3.40	11.52	14.92	1.30		13.22
9	0.0900	216.0	155.5	1.5	3.49	11.52	15.01	1.30		13.27
10	0.1000	220.0	158.4	1.7	3.55	11.52	15.07	1.31		13.30
11	0.2000	241.0	173.5	3.4	3.82	11.52	15.34	1.33		13.43
12	0.3000	278.0	200.2	5.1	4.33	11.52	15.85	1.38		13.69
13	0.4000	291.0	209.5	6.8	4.46	11.52	15.98	1.39		13.75
14	0.5000	320.0	230.4	8.5	4.81	11.52	16.33	1.42		13.93
15	0.6000	331.0	238.3	10.1	4.89	11.52	16.41	1.42		13.96
16	0.7000	342.0	246.2	11.8	4.95	11.52	16.47	1.43		14.00
17	0.8000	375.0	270.0	13.5	5.33	11.52	16.85	1.46		14.18
18	0.9000	385.0	277.2	15.2	5.36	11.52	16.88	1.47		14.20
19	1.0000	389.0	280.1	16.9	5.31	11.52	16.83	1.46		14.17
20	1.1000	411.0	295.9	18.6	5.50	11.52	17.02	1.48		14.27
21	1.2000	405.0	291.6	20.3	5.30	11.52	16.82	1.46		14.17

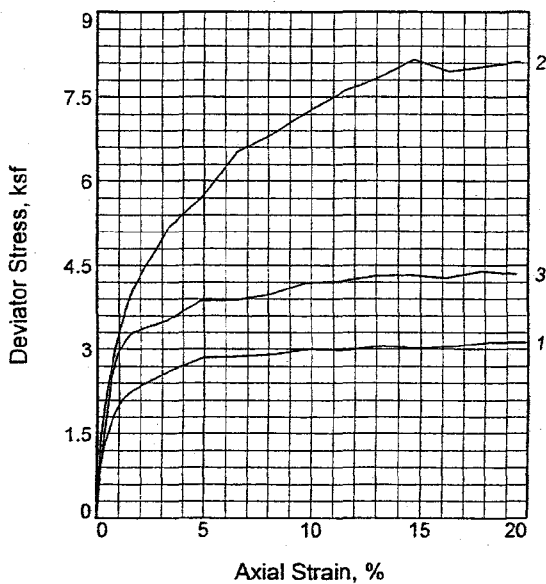
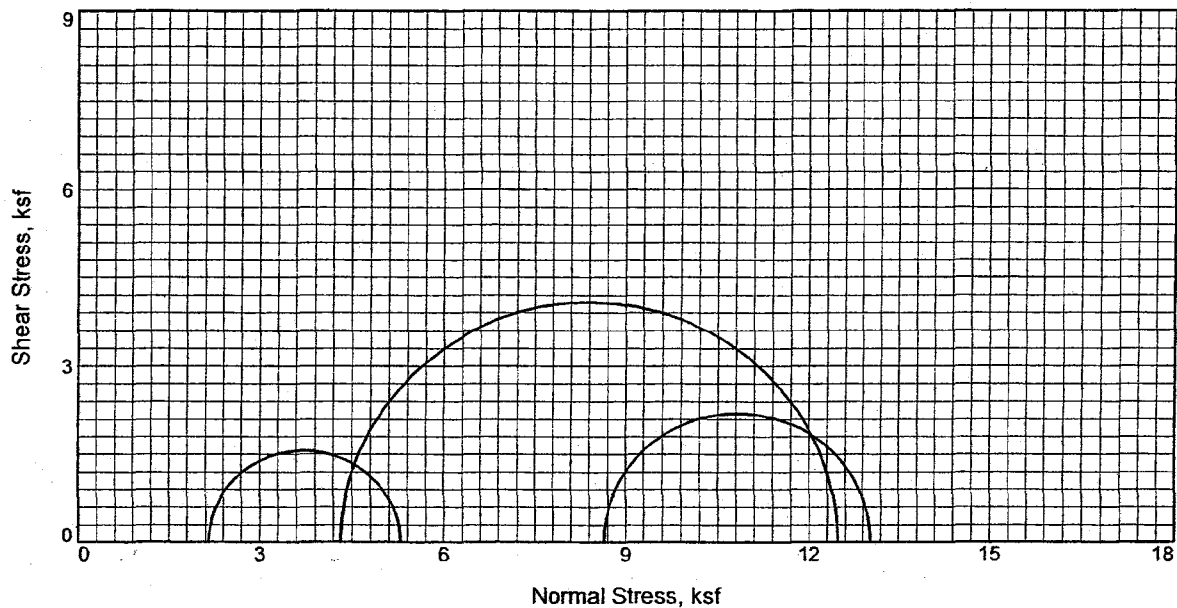

Sample No.	1	2	3	
Initial	Water Content,	26.0	19.5	31.2
	Dry Density, pcf	92.7	105.1	87.3
	Saturation,	87.6	89.6	92.1
	Void Ratio	0.7905	0.5805	0.9011
	Diameter, in.	2.85	2.86	2.83
At Test	Height, in.	6.03	6.12	6.17
	Water Content,	29.7	21.8	33.9
	Dry Density, pcf	92.7	105.1	87.3
	Saturation,	100.0	100.0	100.0
	Void Ratio	0.7905	0.5805	0.9011
	Diameter, in.	2.85	2.86	2.83
	Height, in.	6.03	6.12	6.17
	Strain rate, in./min.	0.02	0.02	0.02
	Back Pressure, ksf	5.8	5.8	5.8
	Cell Pressure, ksf	7.9	10.1	14.4
	Fail. Stress, ksf	3.1	8.2	4.4
	Ult. Stress, ksf			
	$\sigma_1$ Failure, ksf	5.3	12.5	13.0
	$\sigma_3$ Failure, ksf	2.2	4.3	8.6

**Type of Test:**

Unconsolidated Undrained

**Sample Type:** undisturbed

**Description:**

**Assumed Specific Gravity=** 2.66

**Remarks:**

**Client:** TVA

**Project:** TVA Kingston - Proposed Gypsum Stack

**Location:** NB-77A

**Sample Number:** UD-1, 2 & 3 (UU)

**Depth:** 4'-14'

**Proj. No.:** 3043051021

**Date:**

TRIAXIAL SHEAR TEST REPORT

**MACTEC, INC.**

Tested By: Alexander

Checked By: Hamlett

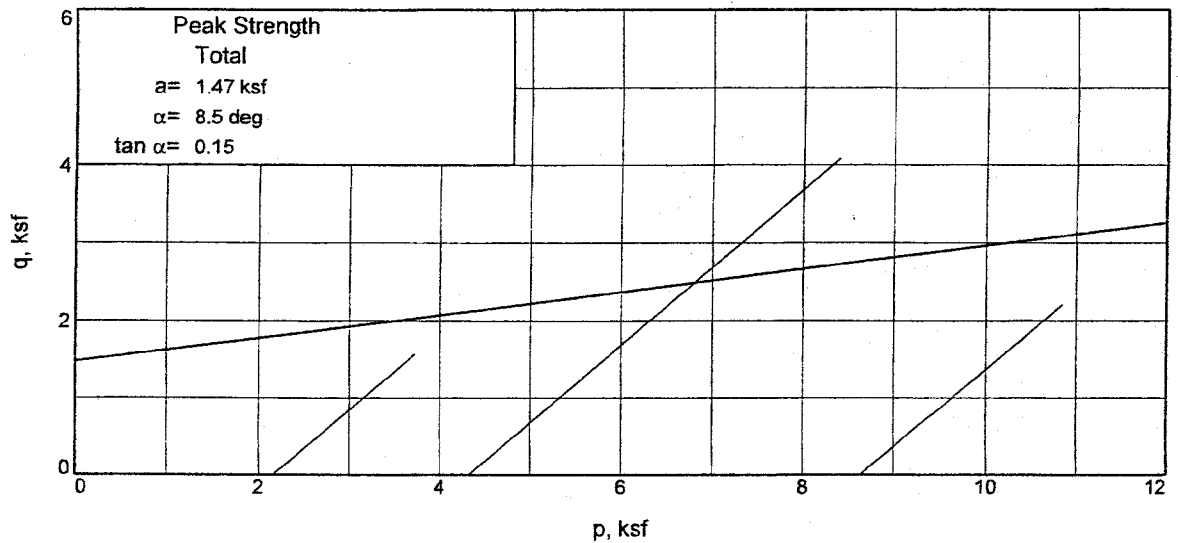
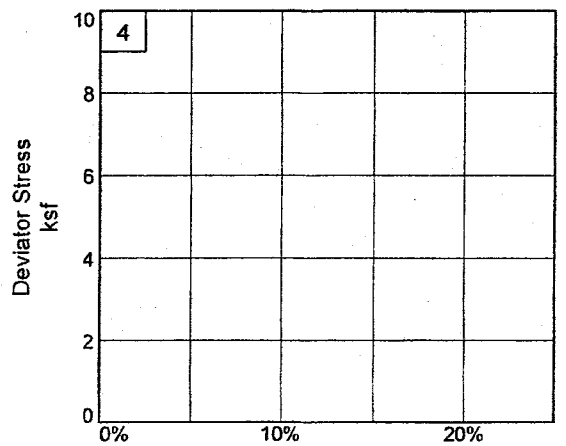
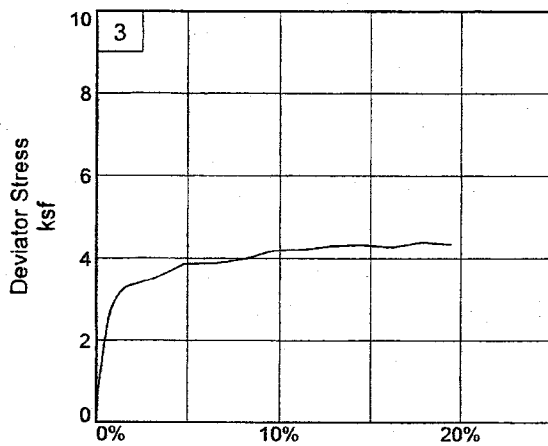
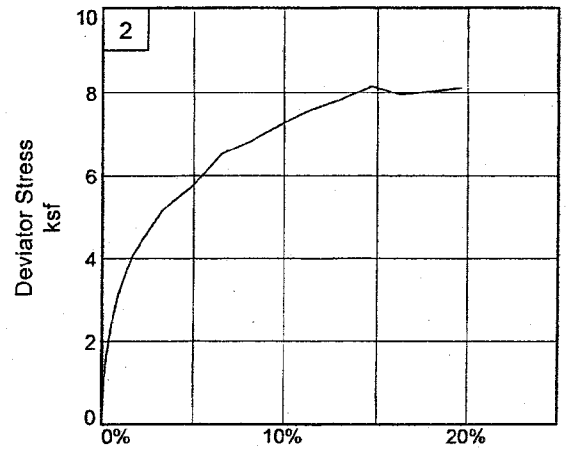
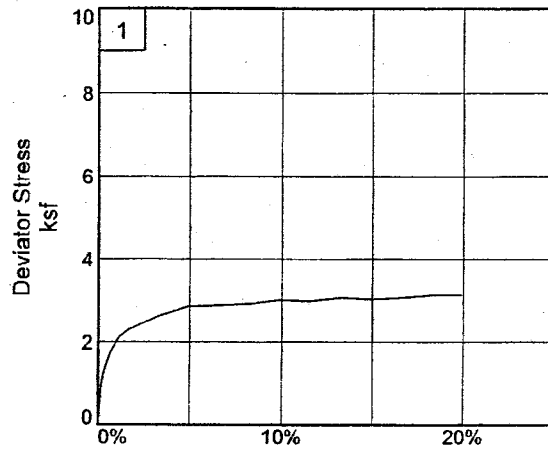

Client: TVA

Project: TVA Kingston - Proposed Gypsum Stack

Location: NB-77

Depth: 4'-14'

Sample Number: UD-1, 2 & 3 (UU)

Project No.: 3043051021

Figure \_\_\_\_\_

**MACTEC, INC.**

Tested By: Alexander \_\_\_\_\_

Checked By: Hamlett \_\_\_\_\_



TRIAXIAL COMPRESSION TEST  
Unconsolidated Undrained

9/13/2005  
8:23 PM

Date:  
Client: TVA  
Project: TVA Kingston - Proposed Gypsum Stack  
Project No.: 3043051021  
Location: NB-77  
Depth: 4'-14'                      Sample Number: UD-1, 2 & 3 (UU)  
Description:  
Remarks:  
Type of Sample: undisturbed  
Specific Gravity=2.66              LL=41              PL=25              PI=16  
Test Method: COE uniform strain

Parameters for Specimen No. 1

Specimen Parameter	Initial	Saturated	Final
Moisture content: Moist soil+tare, gms.	1158.400		557.770
Moisture content: Dry soil+tare, gms.	919.200		435.970
Moisture content: Tare, gms.	0.000		13.420
Moisture, %	26.0	29.7	28.8
Moist specimen weight, gms.	1184.0		
Diameter, in.	2.85	2.85	
Area, in. <sup>2</sup>	6.40	6.40	
Height, in.	6.03	6.03	
Net decrease in height, in.		0.00	
Wet Density, pcf	116.9	120.3	
Dry density, pcf	92.7	92.7	
Void ratio	0.7905	0.7905	
Saturation, %	87.6	100.0	

Readings for Specimen No. 1

Load ring constant = 0.72 lbs. per input unit  
Cell pressure = 55.00 psi (7.92 ksf)  
Back pressure = 40.00 psi (5.76 ksf)  
Effective confining stress = 2.16 ksf  
Strain rate, in./min. = 0.02  
Fail. Stress = 3.13 ksf at reading no. 21

Test Results for Specimen No. 1

No.	Def. Dial in.	Load Dial	Load lbs.	Strain %	Deviator Stress ksf	Minor Princ. Stress ksf	Major Princ. Stress ksf	1:3 Ratio	P ksf	Q ksf
0	0.0000	0.0	0.0	0.0	0.00	2.16	2.16	1.00		2.16
1	0.0100	56.0	40.3	0.2	0.91	2.16	3.07	1.42		2.61
2	0.0200	80.0	57.6	0.3	1.29	2.16	3.45	1.60		2.81
3	0.0300	94.0	67.7	0.5	1.51	2.16	3.67	1.70		2.92
4	0.0400	107.0	77.0	0.7	1.72	2.16	3.88	1.80		3.02
5	0.0500	117.0	84.2	0.8	1.88	2.16	4.04	1.87		3.10
6	0.0600	125.0	90.0	1.0	2.00	2.16	4.16	1.93		3.16
7	0.0700	132.0	95.0	1.2	2.11	2.16	4.27	1.98		3.22
8	0.0800	136.0	97.9	1.3	2.17	2.16	4.33	2.01		3.25
9	0.0900	140.0	100.8	1.5	2.23	2.16	4.39	2.03		3.28
10	0.1000	143.0	103.0	1.7	2.28	2.16	4.44	2.05		3.30
11	0.2000	167.0	120.2	3.3	2.61	2.16	4.77	2.21		3.47
12	0.3000	185.0	133.2	5.0	2.85	2.16	5.01	2.32		3.58
13	0.4000	190.0	136.8	6.6	2.87	2.16	5.03	2.33		3.60
14	0.5000	196.0	141.1	8.3	2.91	2.16	5.07	2.35		3.62
15	0.6000	206.0	148.3	10.0	3.00	2.16	5.16	2.39		3.66
16	0.7000	208.0	149.8	11.6	2.98	2.16	5.14	2.38		3.65
17	0.8000	218.0	157.0	13.3	3.06	2.16	5.22	2.42		3.69
18	0.9000	219.0	157.7	14.9	3.02	2.16	5.18	2.40		3.67
19	1.0000	226.0	162.7	16.6	3.05	2.16	5.21	2.41		3.69
20	1.1000	236.0	169.9	18.2	3.12	2.16	5.28	2.45		3.72
21	1.2000	241.0	173.5	19.9	3.13	2.16	5.29	2.45		3.72

MACTEC, INC.

**Test Results for Specimen No. 2**

Specimen Parameter	Initial	Saturated	Final
Moisture content: Moist soil+tare, gms.	1282.400		670.280
Moisture content: Dry soil+tare, gms.	1072.700		555.710
Moisture content: Tare, gms.	0.000		13.530
Moisture, %	19.5	21.8	21.1
Moist specimen weight, gms.	1299.0		
Diameter, in.	2.86	2.86	
Area, in. <sup>2</sup>	6.44	6.44	
Height, in.	6.12	6.12	
Net decrease in height, in.		0.00	
Wet Density, pcf	125.6	128.0	
Dry density, pcf	105.1	105.1	
Void ratio	0.5805	0.5805	
Saturation, %	89.6	100.0	

**Test Readings for Specimen No. 2**

Load ring constant = 0.72 lbs. per input unit  
 Cell pressure = 70.00 psi (10.08 ksf)  
 Back pressure = 40.00 psi (5.76 ksf)  
 Effective confining stress = 4.32 ksf  
 Strain rate, in./min. = 0.02  
 Fail. Stress = 8.16 ksf at reading no. 18

No.	Def. Dial in.	Load Dial	Load lbs.	Strain %	Deviator Stress ksf	Minor Princ. Stress ksf	Major Princ. Stress ksf	1:3 Ratio	P ksf	Q ksf
0	0.0000	0.0	0.0	0.0	0.00	4.32	4.32	1.00		4.32
1	0.0100	88.0	63.4	0.2	1.41	4.32	5.73	1.33		5.03
2	0.0200	121.0	87.1	0.3	1.94	4.32	6.26	1.45		5.29
3	0.0300	148.0	106.6	0.5	2.37	4.32	6.69	1.55		5.51
4	0.0400	168.0	121.0	0.7	2.69	4.32	7.01	1.62		5.66
5	0.0500	189.0	136.1	0.8	3.02	4.32	7.34	1.70		5.83
6	0.0600	204.0	146.9	1.0	3.25	4.32	7.57	1.75		5.95
7	0.0700	218.0	157.0	1.1	3.47	4.32	7.79	1.80		6.06
8	0.0800	232.0	167.0	1.3	3.69	4.32	8.01	1.85		6.16
9	0.0900	244.0	175.7	1.5	3.87	4.32	8.19	1.90		6.26
10	0.1000	257.0	185.0	1.6	4.07	4.32	8.39	1.94		6.36
11	0.2000	331.0	238.3	3.3	5.16	4.32	9.48	2.19		6.90
12	0.3000	374.0	269.3	4.9	5.73	4.32	10.05	2.33		7.18
13	0.4000	433.0	311.8	6.5	6.52	4.32	10.84	2.51		7.58
14	0.5000	462.0	332.6	8.2	6.83	4.32	11.15	2.58		7.74
15	0.6000	498.0	358.6	9.8	7.23	4.32	11.55	2.67		7.94
16	0.7000	532.0	383.0	11.4	7.59	4.32	11.91	2.76		8.11
17	0.8000	560.0	403.2	13.1	7.84	4.32	12.16	2.81		8.24
18	0.9000	594.0	427.7	14.7	8.16	4.32	12.48	2.89		8.40
19	1.0000	590.0	424.8	16.3	7.95	4.32	12.27	2.84		8.29
20	1.1000	608.0	437.8	18.0	8.03	4.32	12.35	2.86		8.34
21	1.2000	627.0	451.4	19.6	8.12	4.32	12.44	2.88		8.38

Specimen Parameter	Initial	Saturated	Final
Moisture content: Moist soil+tare, gms.	1142.300		567.310
Moisture content: Dry soil+tare, gms.	870.700		427.450
Moisture content: Tare, gms.	0.000		13.570
Moisture, %	31.2	33.9	33.8
Moist specimen weight, gms.	1165.0		
Diameter, in.	2.83	2.83	
Area, in. <sup>2</sup>	6.28	6.28	
Height, in.	6.17	6.17	
Net decrease in height, in.		0.00	
Wet Density, pcf	114.6	116.9	
Dry density, pcf	87.3	87.3	
Void ratio	0.9011	0.9011	
Saturation, %	92.1	100.0	

Load ring constant = 0.72 lbs. per input unit

Cell pressure = 100.00 psi (14.40 ksf)

Back pressure = 40.00 psi (5.76 ksf)

Effective confining stress = 8.64 ksf

Strain rate, in./min. = 0.02

Fail. Stress = 4.39 ksf at reading no. 20

No.	Def. Dial in.	Load Dial	Load lbs.	Strain %	Deviator Stress ksf	Minor Princ. Stress ksf	Major Princ. Stress ksf	1:3 Ratio	P ksf	Q ksf
0	0.0000	0.0	0.0	0.0	0.00	8.64	8.64	1.00		8.64
1	0.0100	54.0	38.9	0.2	0.89	8.64	9.53	1.10		9.08
2	0.0200	90.0	64.8	0.3	1.48	8.64	10.12	1.17		9.38
3	0.0300	125.0	90.0	0.5	2.05	8.64	10.69	1.24		9.67
4	0.0400	151.0	108.7	0.6	2.48	8.64	11.12	1.29		9.88
5	0.0500	168.0	121.0	0.8	2.75	8.64	11.39	1.32		10.02
6	0.0600	180.0	129.6	1.0	2.94	8.64	11.58	1.34		10.11
7	0.0700	187.0	134.6	1.1	3.05	8.64	11.69	1.35		10.17
8	0.0800	194.0	139.7	1.3	3.16	8.64	11.80	1.37		10.22
9	0.0900	199.0	143.3	1.5	3.24	8.64	11.88	1.37		10.26
10	0.1000	203.0	146.2	1.6	3.30	8.64	11.94	1.38		10.29
11	0.2000	220.0	158.4	3.2	3.51	8.64	12.15	1.41		10.40
12	0.3000	246.0	177.1	4.9	3.86	8.64	12.50	1.45		10.57
13	0.4000	251.0	180.7	6.5	3.87	8.64	12.51	1.45		10.58
14	0.5000	262.0	188.6	8.1	3.97	8.64	12.61	1.46		10.63
15	0.6000	281.0	202.3	9.7	4.19	8.64	12.83	1.48		10.73
16	0.7000	288.0	207.4	11.4	4.21	8.64	12.85	1.49		10.75
17	0.8000	300.0	216.0	13.0	4.31	8.64	12.95	1.50		10.79
18	0.9000	307.0	221.0	14.6	4.33	8.64	12.97	1.50		10.80
19	1.0000	309.0	222.5	16.2	4.27	8.64	12.91	1.49		10.78
20	1.1000	324.0	233.3	17.8	4.39	8.64	13.03	1.51		10.84
21	1.2000	327.0	235.4	19.5	4.35	8.64	12.99	1.50		10.81

MACTEC, INC.

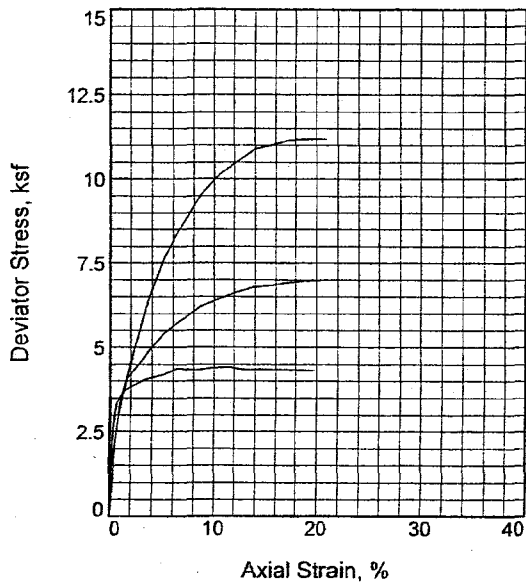
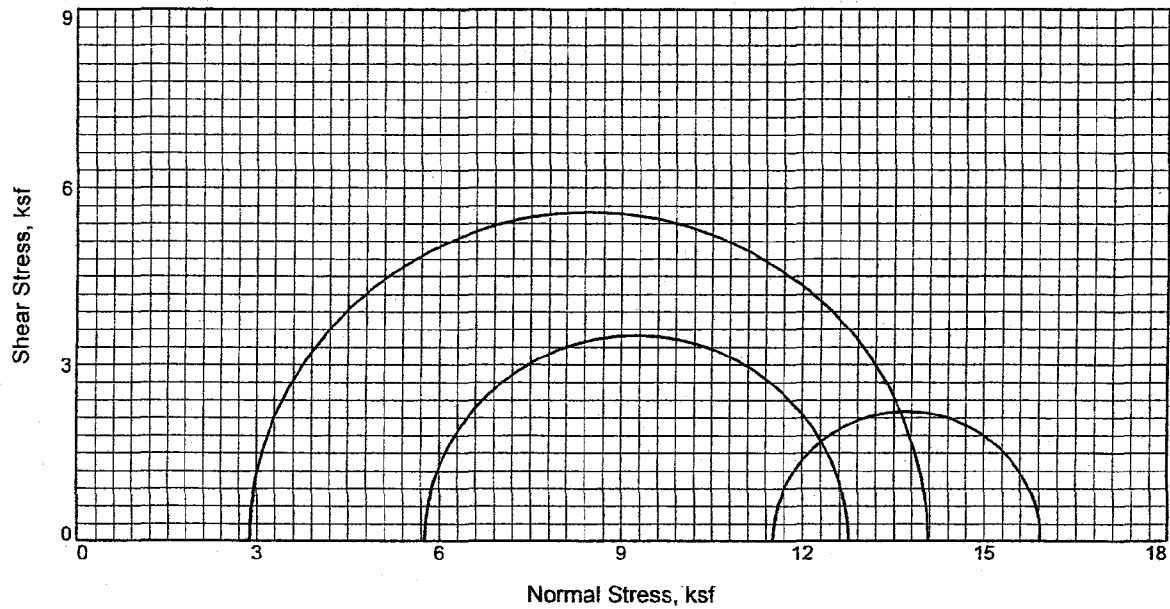

Sample No.	1	2	3	
Initial	Water Content,	21.2	21.1	39.8
	Dry Density, pcf	92.4	96.8	79.9
	Saturation,	71.5	79.3	98.8
	Void Ratio	0.7838	0.7029	1.0625
	Diameter, in.	2.87	2.87	2.83
Height, in.	5.73	5.82	6.09	
At Test	Water Content,	29.7	26.6	40.2
	Dry Density, pcf	92.4	96.8	79.9
	Saturation,	100.0	100.0	100.0
	Void Ratio	0.7838	0.7029	1.0625
	Diameter, in.	2.87	2.87	2.83
Height, in.	5.73	5.82	6.09	
Strain rate, in./min.	0.02	0.02	0.02	
Back Pressure, ksf	2.9	2.9	2.9	
Cell Pressure, ksf	5.8	8.6	14.4	
Fail. Stress, ksf	11.2	7.0	4.4	
Ult. Stress, ksf				
$\sigma_1$ Failure, ksf	14.1	12.8	15.9	
$\sigma_3$ Failure, ksf	2.9	5.8	11.5	

**Type of Test:**  
Unconsolidated Undrained

**Sample Type:** undisturbed

**Description:**

**Assumed Specific Gravity=** 2.64

**Remarks:**

**Client:** TVA

**Project:** TVA Kingston - Proposed Gypsum Stack

**Location:** NB-77A

**Sample Number:** UD-4, 6 & 7 (UU)

**Depth:** 15'-26'

**Proj. No.:** 3043051021

**Date:**

TRIAXIAL SHEAR TEST REPORT

**MACTEC, INC.**

Figure \_\_\_\_\_

Tested By: Alexander

Checked By: Hamlett

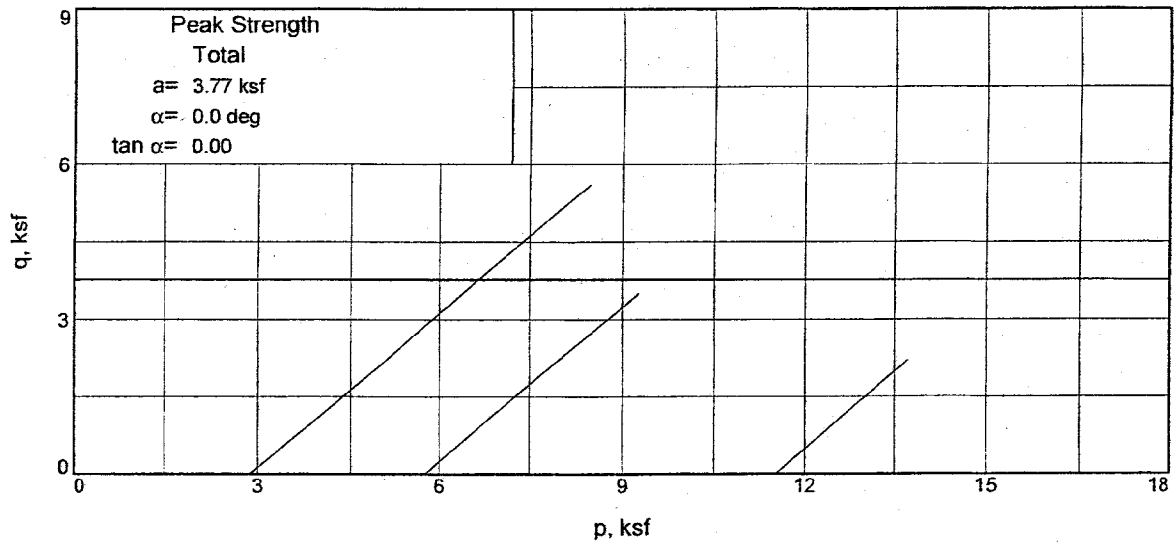
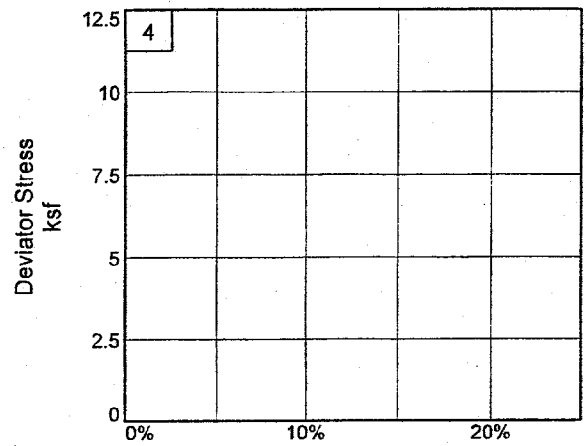
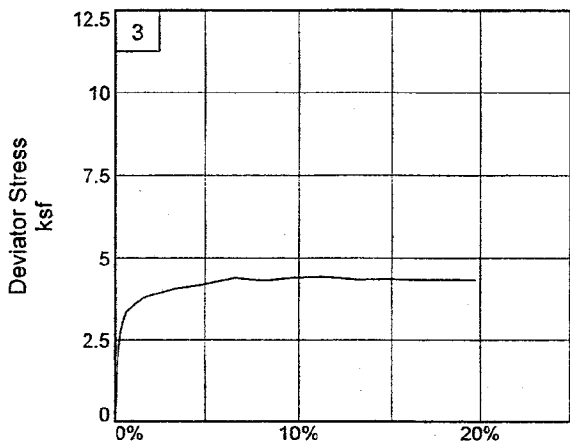
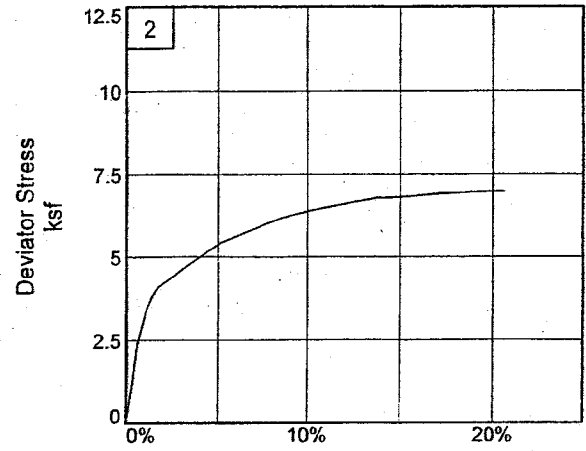
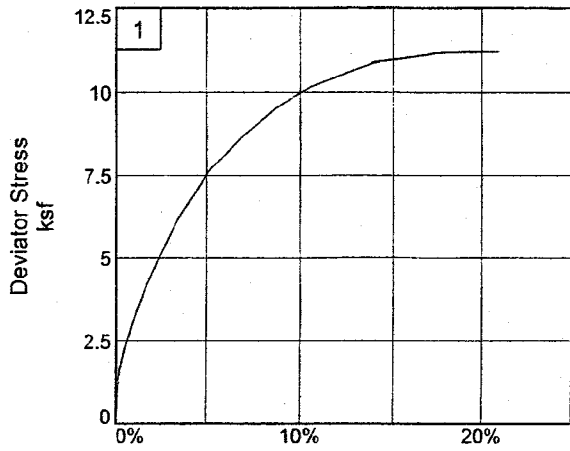

Client: TVA

Project: TVA Kingston - Proposed Gypsum Stack

Location: NB-77A

Depth: 15'-26'

Sample Number: UD-4, 6 & 7 (UU)

Project No.: 3043051021

Figure \_\_\_\_\_

**MACTEC, INC.**

Tested By: Alexander

Checked By: Hamlett

**TRIAxIAL COMPRESSION TEST**

Unconsolidated Undrained

9/19/2005

1:38 PM

Date:  
 Client: TVA  
 Project: TVA Kingston - Proposed Gypsum Stack  
 Project No.: 3043051021  
 Location: NB-77A  
 Depth: 15'-26' Sample Number: UD-4, 6 & 7 (UU)  
 Description:  
 Remarks:  
 Type of Sample: undisturbed  
 Assumed Specific Gravity=2.64 LL= PL= Pi=  
 Test Method: COE uniform strain

**Parameters for Specimen No. 1**

Specimen Parameter	Initial	Saturated	Final
Moisture content: Moist soil+tare, gms.	1078.860		460.990
Moisture content: Dry soil+tare, gms.	890.040		376.420
Moisture content: Tare, gms.	0.000		14.130
Moisture, %	21.2	29.7	23.3
Moist specimen weight, gms.	1090.3		
Diameter, in.	2.87	2.87	
Area, in. <sup>2</sup>	6.47	6.47	
Height, in.	5.73	5.73	
Net decrease in height, in.		0.00	
Wet Density, pcf	112.0	119.8	
Dry density, pcf	92.4	92.4	
Void ratio	0.7838	0.7838	
Saturation, %	71.5	100.0	

**Test Readings for Specimen No. 1**

Load ring constant = 0.72 lbs. per input unit  
 Cell pressure = 40.00 psi (5.76 ksf)  
 Back pressure = 20.00 psi (2.88 ksf)  
 Effective confining stress = 2.88 ksf  
 Strain rate, in./min. = 0.02  
 Fail. Stress = 11.19 ksf at reading no. 20

Test Readings for Specimen No. 1

No.	Def. Dial in.	Load Dial	Load lbs.	Strain %	Deviator Stress ksf	Minor Princ. Stress ksf	Major Princ. Stress ksf	1:3 Ratio	P ksf	Q ksf
0	0.0000	0.0	0.0	0.0	0.00	2.88	2.88	1.00		2.88
1	0.0100	90.0	64.8	0.2	1.44	2.88	4.32	1.50		3.60
2	0.0200	118.0	85.0	0.3	1.88	2.88	4.76	1.65		3.82
3	0.0300	143.0	103.0	0.5	2.28	2.88	5.16	1.79		4.02
4	0.0400	163.0	117.4	0.7	2.59	2.88	5.47	1.90		4.18
5	0.0500	184.0	132.5	0.9	2.92	2.88	5.80	2.01		4.34
6	0.0600	203.0	146.2	1.0	3.22	2.88	6.10	2.12		4.49
7	0.0700	219.0	157.7	1.2	3.47	2.88	6.35	2.20		4.61
8	0.0800	236.0	169.9	1.4	3.73	2.88	6.61	2.29		4.74
9	0.0900	252.0	181.4	1.6	3.98	2.88	6.86	2.38		4.87
10	0.1000	267.0	192.2	1.7	4.20	2.88	7.08	2.46		4.98
11	0.2000	403.0	290.2	3.5	6.23	2.88	9.11	3.16		6.00
12	0.3000	508.0	365.8	5.2	7.72	2.88	10.60	3.68		6.74
13	0.4000	582.0	419.0	7.0	8.68	2.88	11.56	4.01		7.22
14	0.5000	652.0	469.4	8.7	9.54	2.88	12.42	4.31		7.65
15	0.6000	706.0	508.3	10.5	10.13	2.88	13.01	4.52		7.95
16	0.7000	747.0	537.8	12.2	10.51	2.88	13.39	4.65		8.14
17	0.8000	789.0	568.1	14.0	10.88	2.88	13.76	4.78		8.32
18	0.9000	814.0	586.1	15.7	11.00	2.88	13.88	4.82		8.38
19	1.0000	843.0	607.0	17.4	11.15	2.88	14.03	4.87		8.46
20	1.1000	864.0	622.1	19.2	11.19	2.88	14.07	4.89		8.48
21	1.2000	883.0	635.8	20.9	11.19	2.88	14.07	4.89		8.47

MACTEC, INC.



**Parameters for Specimen No. 2**

Specimen Parameter	Initial	Saturated	Final
Moisture content: Moist soil+tare, gms.	1154.900		634.320
Moisture content: Dry soil+tare, gms.	953.580		520.590
Moisture content: Tare, gms.	0.000		11.220
Moisture, %	21.1	26.6	22.3
Moist specimen weight, gms.	1161.5		
Diameter, in.	2.87	2.87	
Area, in. <sup>2</sup>	6.48	6.48	
Height, in.	5.82	5.82	
Net decrease in height, in.		0.00	
Wet Density, pcf	117.2	122.5	
Dry density, pcf	96.8	96.8	
Void ratio	0.7029	0.7029	
Saturation, %	79.3	100.0	

**Test Readings for Specimen No. 2**

Load ring constant = 0.72 lbs. per input unit  
 Cell pressure = 60.00 psi (8.64 ksf)  
 Back pressure = 20.00 psi (2.88 ksf)  
 Effective confining stress = 5.76 ksf  
 Strain rate, in./min. = 0.02  
 Fail. Stress = 7.00 ksf at reading no. 21

No.	Def. Dial in.	Load Dial	Load lbs.	Strain %	Deviator Stress ksf	Minor Princ. Stress ksf	Major Princ. Stress ksf	1:3 Ratio	P ksf	Q ksf
0	0.0000	0.0	0.0	0.0	0.00	5.76	5.76	1.00		5.76
1	0.0100	42.0	30.2	0.2	0.67	5.76	6.43	1.12		6.10
2	0.0200	84.0	60.5	0.3	1.34	5.76	7.10	1.23		6.43
3	0.0300	137.0	98.6	0.5	2.18	5.76	7.94	1.38		6.85
4	0.0400	167.0	120.2	0.7	2.65	5.76	8.41	1.46		7.09
5	0.0500	189.0	136.1	0.9	3.00	5.76	8.76	1.52		7.26
6	0.0600	212.0	152.6	1.0	3.36	5.76	9.12	1.58		7.44
7	0.0700	227.0	163.4	1.2	3.59	5.76	9.35	1.62		7.55
8	0.0800	241.0	173.5	1.4	3.80	5.76	9.56	1.66		7.66
9	0.0900	251.0	180.7	1.5	3.95	5.76	9.71	1.69		7.74
10	0.1000	260.0	187.2	1.7	4.09	5.76	9.85	1.71		7.80
11	0.2000	310.0	223.2	3.4	4.79	5.76	10.55	1.83		8.15
12	0.3000	358.0	257.8	5.2	5.43	5.76	11.19	1.94		8.48
13	0.4000	390.0	280.8	6.9	5.81	5.76	11.57	2.01		8.66
14	0.5000	423.0	304.6	8.6	6.18	5.76	11.94	2.07		8.85
15	0.6000	447.0	321.8	10.3	6.41	5.76	12.17	2.11		8.97
16	0.7000	469.0	337.7	12.0	6.60	5.76	12.36	2.15		9.06
17	0.8000	491.0	353.5	13.7	6.77	5.76	12.53	2.18		9.15
18	0.9000	505.0	363.6	15.5	6.83	5.76	12.59	2.19		9.17
19	1.0000	522.0	375.8	17.2	6.91	5.76	12.67	2.20		9.22
20	1.1000	537.0	386.6	18.9	6.97	5.76	12.73	2.21		9.24
21	1.2000	551.0	396.7	20.6	7.00	5.76	12.76	2.21		9.26

**Parameters for Specimen No. 2**

Specimen Parameter	Initial	Saturated	Final
Moisture content: Moist soil+tare, gms.	1114.200		526.400
Moisture content: Dry soil+tare, gms.	797.260		373.280
Moisture content: Tare, gms.	0.000		8.080
Moisture, %	39.8	40.2	41.9
Moist specimen weight, gms.	1124.1		
Diameter, in.	2.83	2.83	
Area, in. <sup>2</sup>	6.30	6.30	
Height, in.	6.09	6.09	
Net decrease in height, in.		0.00	
Wet Density, pcf	111.7	112.1	
Dry density, pcf	79.9	79.9	
Void ratio	1.0625	1.0625	
Saturation, %	98.8	100.0	

**Test Readings for Specimen No. 2**

Load ring constant = 0.72 lbs. per input unit  
 Cell pressure = 100.00 psi (14.40 ksf)  
 Back pressure = 20.00 psi (2.88 ksf)  
 Effective confining stress = 11.52 ksf  
 Strain rate, in./min. = 0.02  
 Fail. Stress = 4.41 ksf at reading no. 16

No.	Def. Dial in.	Load Dial	Load lbs.	Strain %	Deviator Stress ksf	Minor Princ. Stress ksf	Major Princ. Stress ksf	1:3 Ratio	P ksf	Q ksf
0	0.0000	0.0	0.0	0.0	0.00	11.52	11.52	1.00		11.52
1	0.0100	117.0	84.2	0.2	1.92	11.52	13.44	1.17		12.48
2	0.0200	166.0	119.5	0.3	2.72	11.52	14.24	1.24		12.88
3	0.0300	190.0	136.8	0.5	3.11	11.52	14.63	1.27		13.08
4	0.0400	205.0	147.6	0.7	3.35	11.52	14.87	1.29		13.20
5	0.0500	210.0	151.2	0.8	3.43	11.52	14.95	1.30		13.23
6	0.0600	215.0	154.8	1.0	3.50	11.52	15.02	1.30		13.27
7	0.0700	221.0	159.1	1.1	3.60	11.52	15.12	1.31		13.32
8	0.0800	225.0	162.0	1.3	3.65	11.52	15.17	1.32		13.35
9	0.0900	230.0	165.6	1.5	3.73	11.52	15.25	1.32		13.38
10	0.1000	233.0	167.8	1.6	3.77	11.52	15.29	1.33		13.41
11	0.2000	254.0	182.9	3.3	4.04	11.52	15.56	1.35		13.54
12	0.3000	267.0	192.2	4.9	4.18	11.52	15.70	1.36		13.61
13	0.4000	285.0	205.2	6.6	4.38	11.52	15.90	1.38		13.71
14	0.5000	285.0	205.2	8.2	4.31	11.52	15.83	1.37		13.67
15	0.6000	296.0	213.1	9.9	4.39	11.52	15.91	1.38		13.72
16	0.7000	303.0	218.2	11.5	4.41	11.52	15.93	1.38		13.73
17	0.8000	303.0	218.2	13.1	4.33	11.52	15.85	1.38		13.69
18	0.9000	310.0	223.2	14.8	4.35	11.52	15.87	1.38		13.69
19	1.0000	315.0	226.8	16.4	4.33	11.52	15.85	1.38		13.69
20	1.1000	321.0	231.1	18.1	4.33	11.52	15.85	1.38		13.68
21	1.2000	327.0	235.4	19.7	4.32	11.52	15.84	1.38		13.68

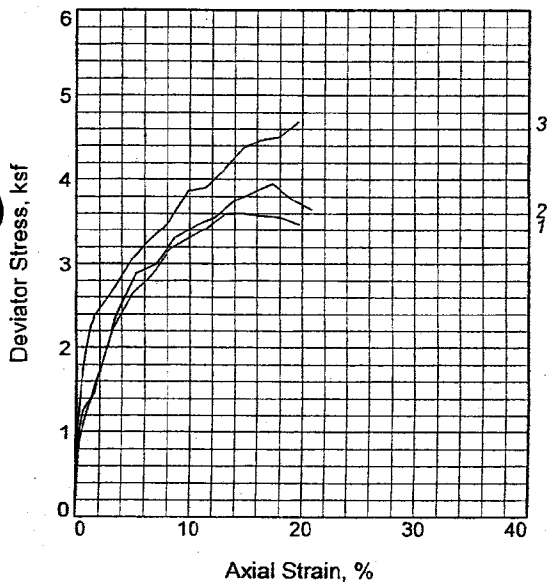
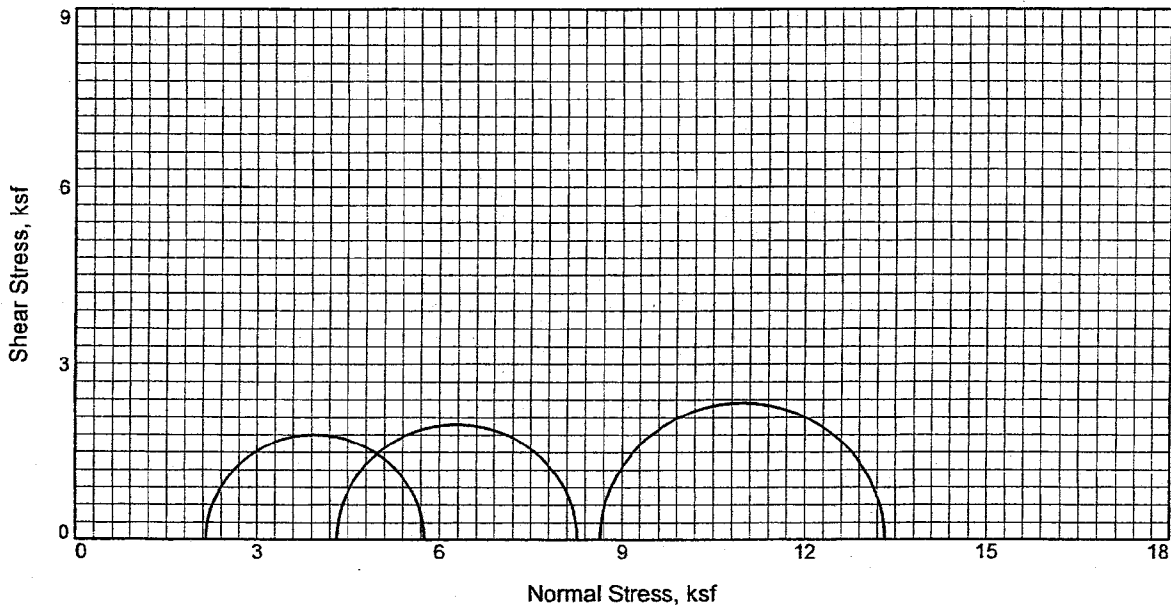

Sample No.	1	2	3	
Initial	Water Content,	25.0	25.0	25.0
	Dry Density, pcf	96.5	98.5	99.8
	Saturation,	92.2	96.8	100.0
	Void Ratio	0.7215	0.6855	0.6647
	Diameter, in.	2.84	2.86	2.91
	Height, in.	6.09	5.75	6.11
At Test	Water Content,	27.1	25.8	25.0
	Dry Density, pcf	96.5	98.5	99.8
	Saturation,	100.0	100.0	100.0
	Void Ratio	0.7215	0.6855	0.6647
	Diameter, in.	2.84	2.86	2.91
	Height, in.	6.09	5.75	6.11
Strain rate, in./min.	0.02	0.02	0.02	
Back Pressure, ksf	5.8	5.8	5.8	
Cell Pressure, ksf	7.9	10.1	14.4	
Fail. Stress, ksf	3.6	4.0	4.7	
Ult. Stress, ksf				
$\sigma_1$ Failure, ksf	5.8	8.3	13.3	
$\sigma_3$ Failure, ksf	2.2	4.3	8.6	

**Type of Test:**

Unconsolidated Undrained

**Sample Type:** undisturbed

**Description:**

**Assumed Specific Gravity=** 2.66

**Remarks:**

**Client:** TVA

**Project:** TVA Kingston - Proposed Gypsum Stack

**Location:** NB-85A and NB-85B

**Sample Number:** UD-1, 2 & 3 (UU)

**Depth:** 13'-19'

**Proj. No.:** 3043051021

**Date:**

TRIAXIAL SHEAR TEST REPORT

**MACTEC, INC.**

Figure \_\_\_\_\_

Tested By: Alexander \_\_\_\_\_

Checked By: Hamlett \_\_\_\_\_

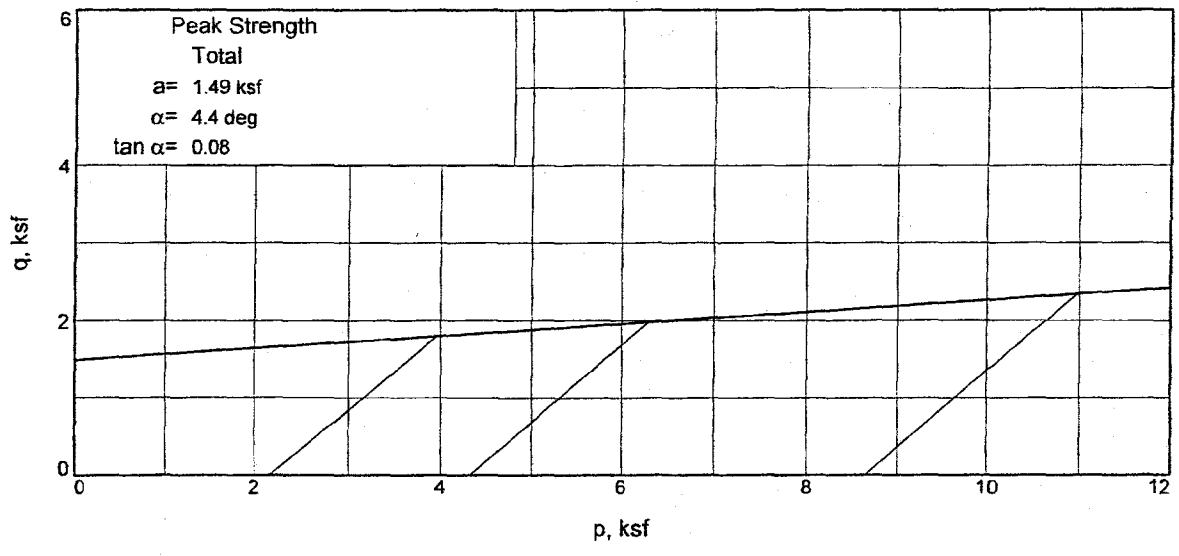
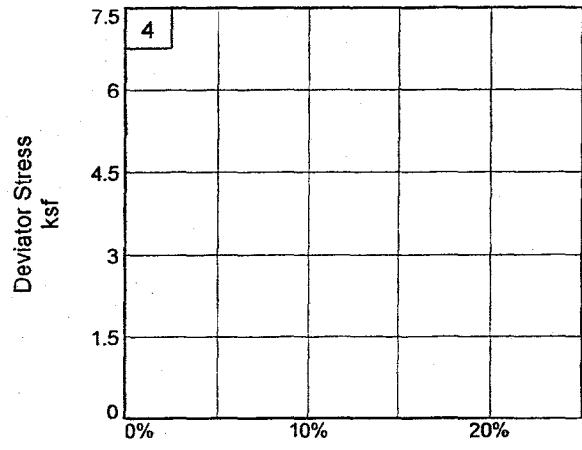
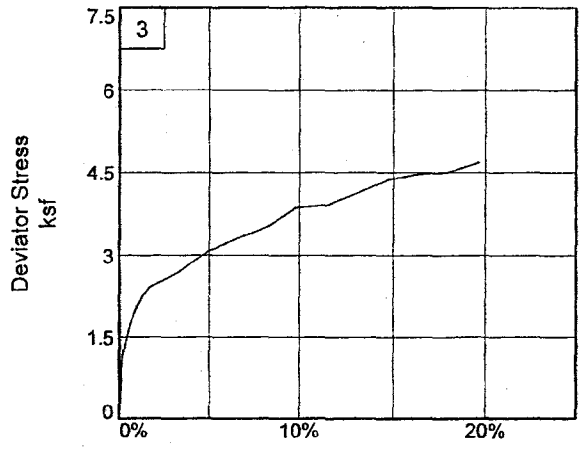
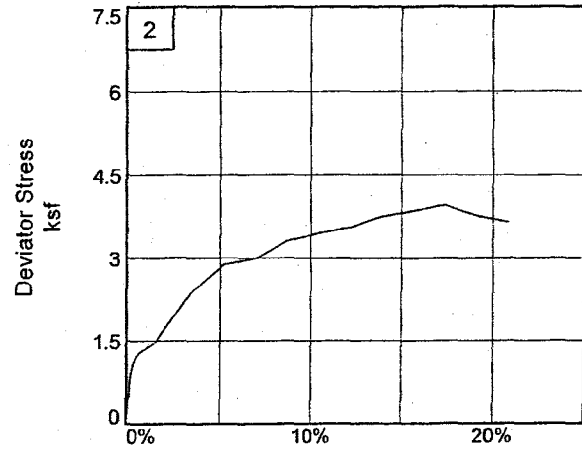
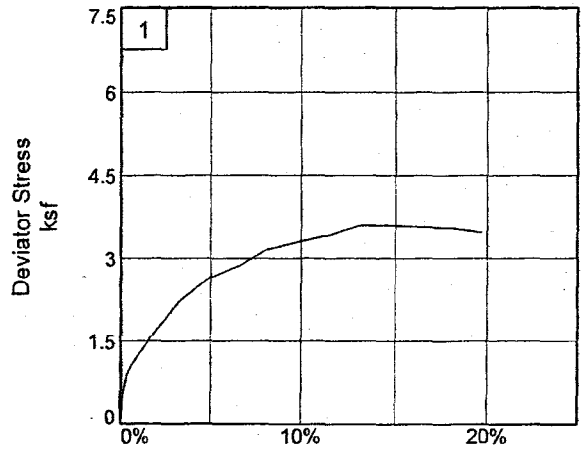

**Client:** TVA  
**Project:** TVA Kingston - Proposed Gypsum Stack  
**Location:** NB-85A and NB-85B  
**Project No.:** 3043051021  
**Depth:** 13'-19'  
**Figure** \_\_\_\_\_  
**Sample Number:** UD-1, 2 & 3 (UU)  
**MACTEC, INC.**

**Tested By:** Alexander  
**Checked By:** Hamlett

**TRIAxIAL COMPRESSION TEST**  
Unconsolidated Undrained

9/13/2005  
9:41 PM

Date:  
 Client: TVA  
 Project: TVA Kingston - Proposed Gypsum Stack  
 Project No.: 3043051021  
 Location: NB-85A and NB-85B  
 Depth: 13'-19' **Sample Number:** UD-1, 2 & 3 (UU)  
 Description:  
 Remarks:  
 Type of Sample: undisturbed  
 Specific Gravity=2.66 LL= PL= PI=  
 Test Method: COE uniform strain

**Parameters for Specimen No. 1**

Specimen Parameter	Initial	Saturated	Final
Moisture content: Moist soil+tare, gms.	1220.400		1336.600
Moisture content: Dry soil+tare, gms.	976.200		1068.970
Moisture content: Tare, gms.	0.000		93.350
Moisture, %	25.0	27.1	27.4
Moist specimen weight, gms.	1220.4		
Diameter, in.	2.84	2.84	
Area, in. <sup>2</sup>	6.33	6.33	
Height, in.	6.09	6.09	
Net decrease in height, in.		0.00	
Wet Density, pcf	120.6	122.6	
Dry density, pcf	96.5	96.5	
Void ratio	0.7215	0.7215	
Saturation, %	92.2	100.0	

**Test Readings for Specimen No. 1**

Load ring constant = 0.72 lbs. per input unit  
 Cell pressure = 55.00 psi (7.92 ksf)  
 Back pressure = 40.00 psi (5.76 ksf)  
 Effective confining stress = 2.16 ksf  
 Strain rate, in./min. = 0.02  
 Fail. Stress = 3.60 ksf at reading no. 18

No.	Def. Dial in.	Load Dial	Load lbs.	Strain %	Deviator Stress ksf	Minor Princ. Stress ksf	Major Princ. Stress ksf	1:3 Ratio	P ksf	Q ksf
0	0.0000	0.0	0.0	0.0	0.00	2.16	2.16	1.00		2.16
1	0.0100	40.0	28.8	0.2	0.65	2.16	2.81	1.30		2.49
2	0.0200	55.0	39.6	0.3	0.90	2.16	3.06	1.42		2.61
3	0.0300	62.0	44.6	0.5	1.01	2.16	3.17	1.47		2.66
4	0.0400	68.0	49.0	0.7	1.11	2.16	3.27	1.51		2.71
5	0.0500	73.0	52.6	0.8	1.18	2.16	3.34	1.55		2.75
6	0.0600	78.0	56.2	1.0	1.26	2.16	3.42	1.59		2.79
7	0.0700	82.0	59.0	1.2	1.33	2.16	3.49	1.61		2.82
8	0.0800	87.0	62.6	1.3	1.41	2.16	3.57	1.65		2.86
9	0.0900	92.0	66.2	1.5	1.48	2.16	3.64	1.69		2.90
10	0.1000	97.0	69.8	1.6	1.56	2.16	3.72	1.72		2.94
11	0.2000	141.0	101.5	3.3	2.23	2.16	4.39	2.03		3.28
12	0.3000	170.0	122.4	4.9	2.65	2.16	4.81	2.22		3.48
13	0.4000	187.0	134.6	6.6	2.86	2.16	5.02	2.32		3.59
14	0.5000	211.0	151.9	8.2	3.17	2.16	5.33	2.47		3.74
15	0.6000	224.0	161.3	9.9	3.30	2.16	5.46	2.53		3.81
16	0.7000	236.0	169.9	11.5	3.42	2.16	5.58	2.58		3.87
17	0.8000	253.0	182.2	13.1	3.60	2.16	5.76	2.67		3.96
18	0.9000	258.0	185.8	14.8	3.60	2.16	5.76	2.67		3.96
19	1.0000	261.0	187.9	16.4	3.57	2.16	5.73	2.65		3.94
20	1.1000	265.0	190.8	18.1	3.55	2.16	5.71	2.65		3.94
21	1.2000	264.0	190.1	19.7	3.47	2.16	5.63	2.61		3.89

**Test Results for Specimen No. 2**

Specimen Parameter	Initial	Saturated	Final
Moisture content: Moist soil+tare, gms.	1192.400		1305.860
Moisture content: Dry soil+tare, gms.	954.290		1061.280
Moisture content: Tare, gms.	0.000		91.170
Moisture, %	25.0	25.8	25.2
Moist specimen weight, gms.	1192.4		
Diameter, in.	2.86	2.86	
Area, in. <sup>2</sup>	6.42	6.42	
Height, in.	5.75	5.75	
Net decrease in height, in.		0.00	
Wet Density, pcf	123.1	123.9	
Dry density, pcf	98.5	98.5	
Void ratio	0.6855	0.6855	
Saturation, %	96.8	100.0	

**Test Readings for Specimen No. 2**

Load ring constant = 0.72 lbs. per input unit  
 Cell pressure = 70.00 psi (10.08 ksf)  
 Back pressure = 40.00 psi (5.76 ksf)  
 Effective confining stress = 4.32 ksf  
 Strain rate, in./min. = 0.02  
 Fail. Stress = 3.95 ksf at reading no. 19

No.	Def. Dial in.	Load Dial	Load lbs.	Strain %	Deviator Stress ksf	Minor Princ. Stress ksf	Major Princ. Stress ksf	1:3 Ratio	P ksf	Q ksf
0	0.0000	0.0	0.0	0.0	0.00	4.32	4.32	1.00		4.32
1	0.0100	48.0	34.6	0.2	0.77	4.32	5.09	1.18		4.71
2	0.0200	67.0	48.2	0.3	1.08	4.32	5.40	1.25		4.86
3	0.0300	75.0	54.0	0.5	1.21	4.32	5.53	1.28		4.92
4	0.0400	79.0	56.9	0.7	1.27	4.32	5.59	1.29		4.95
5	0.0500	82.0	59.0	0.9	1.31	4.32	5.63	1.30		4.98
6	0.0600	84.0	60.5	1.0	1.34	4.32	5.66	1.31		4.99
7	0.0700	87.0	62.6	1.2	1.39	4.32	5.71	1.32		5.01
8	0.0800	89.0	64.1	1.4	1.42	4.32	5.74	1.33		5.03
9	0.0900	92.0	66.2	1.6	1.46	4.32	5.78	1.34		5.05
10	0.1000	99.0	71.3	1.7	1.57	4.32	5.89	1.36		5.11
11	0.2000	152.0	109.4	3.5	2.37	4.32	6.69	1.55		5.51
12	0.3000	188.0	135.4	5.2	2.88	4.32	7.20	1.67		5.76
13	0.4000	199.0	143.3	7.0	2.99	4.32	7.31	1.69		5.82
14	0.5000	224.0	161.3	8.7	3.31	4.32	7.63	1.77		5.97
15	0.6000	238.0	171.4	10.4	3.45	4.32	7.77	1.80		6.04
16	0.7000	250.0	180.0	12.2	3.55	4.32	7.87	1.82		6.09
17	0.8000	269.0	193.7	13.9	3.74	4.32	8.06	1.87		6.19
18	0.9000	282.0	203.0	15.6	3.84	4.32	8.16	1.89		6.24
19	1.0000	296.0	213.1	17.4	3.95	4.32	8.27	1.91		6.30
20	1.1000	288.0	207.4	19.1	3.76	4.32	8.08	1.87		6.20
21	1.2000	285.0	205.2	20.9	3.65	4.32	7.97	1.84		6.14

**Parameters for Specimen No. 3**

Specimen Parameter	Initial	Saturated	Final
Moisture content: Moist soil+tare, gms.	1326.900		1440.860
Moisture content: Dry soil+tare, gms.	1061.520		1221.470
Moisture content: Tare, gms.	0.000		87.240
Moisture, %	25.0	25.0	19.3
Moist specimen weight, gms.	1326.9		
Diameter, in.	2.91	2.91	
Area, in. <sup>2</sup>	6.64	6.64	
Height, in.	6.11	6.11	
Net decrease in height, in.		0.00	
Wet Density, pcf	124.7	124.7	
Dry density, pcf	99.8	99.8	
Void ratio	0.6647	0.6647	
Saturation, %	100.0	100.0	

**Test Readings for Specimen No. 3**

Load ring constant = 0.72 lbs. per input unit  
 Cell pressure = 100.00 psi (14.40 ksf)  
 Back pressure = 40.00 psi (5.76 ksf)  
 Effective confining stress = 8.64 ksf  
 Strain rate, in./min. = 0.02  
 Fail. Stress = 4.68 ksf at reading no. 21

No.	Def. Dial in.	Load Dial	Load lbs.	Strain %	Deviator Stress ksf	Minor Princ. Stress ksf	Major Princ. Stress ksf	1:3 Ratio	P ksf	Q ksf
0	0.0000	0.0	0.0	0.0	0.00	8.64	8.64	1.00		8.64
1	0.0100	72.0	51.8	0.2	1.12	8.64	9.76	1.13		9.20
2	0.0200	89.0	64.1	0.3	1.39	8.64	10.03	1.16		9.33
3	0.0300	102.0	73.4	0.5	1.59	8.64	10.23	1.18		9.43
4	0.0400	114.0	82.1	0.7	1.77	8.64	10.41	1.20		9.52
5	0.0500	124.0	89.3	0.8	1.92	8.64	10.56	1.22		9.60
6	0.0600	133.0	95.8	1.0	2.06	8.64	10.70	1.24		9.67
7	0.0700	140.0	100.8	1.1	2.16	8.64	10.80	1.25		9.72
8	0.0800	147.0	105.8	1.3	2.27	8.64	10.91	1.26		9.77
9	0.0900	150.0	108.0	1.5	2.31	8.64	10.95	1.27		9.79
10	0.1000	156.0	112.3	1.6	2.40	8.64	11.04	1.28		9.84
11	0.2000	178.0	128.2	3.3	2.69	8.64	11.33	1.31		9.98
12	0.3000	206.0	148.3	4.9	3.06	8.64	11.70	1.35		10.17
13	0.4000	226.0	162.7	6.5	3.30	8.64	11.94	1.38		10.29
14	0.5000	244.0	175.7	8.2	3.50	8.64	12.14	1.41		10.39
15	0.6000	274.0	197.3	9.8	3.86	8.64	12.50	1.45		10.57
16	0.7000	282.0	203.0	11.5	3.90	8.64	12.54	1.45		10.59
17	0.8000	304.0	218.9	13.1	4.13	8.64	12.77	1.48		10.70
18	0.9000	328.0	236.2	14.7	4.37	8.64	13.01	1.51		10.82
19	1.0000	342.0	246.2	16.4	4.47	8.64	13.11	1.52		10.87
20	1.1000	352.0	253.4	18.0	4.51	8.64	13.15	1.52		10.89
21	1.2000	373.0	268.6	19.6	4.68	8.64	13.32	1.54		10.98



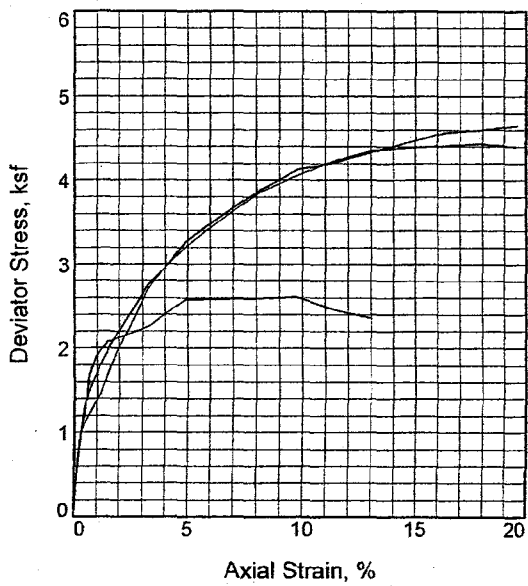
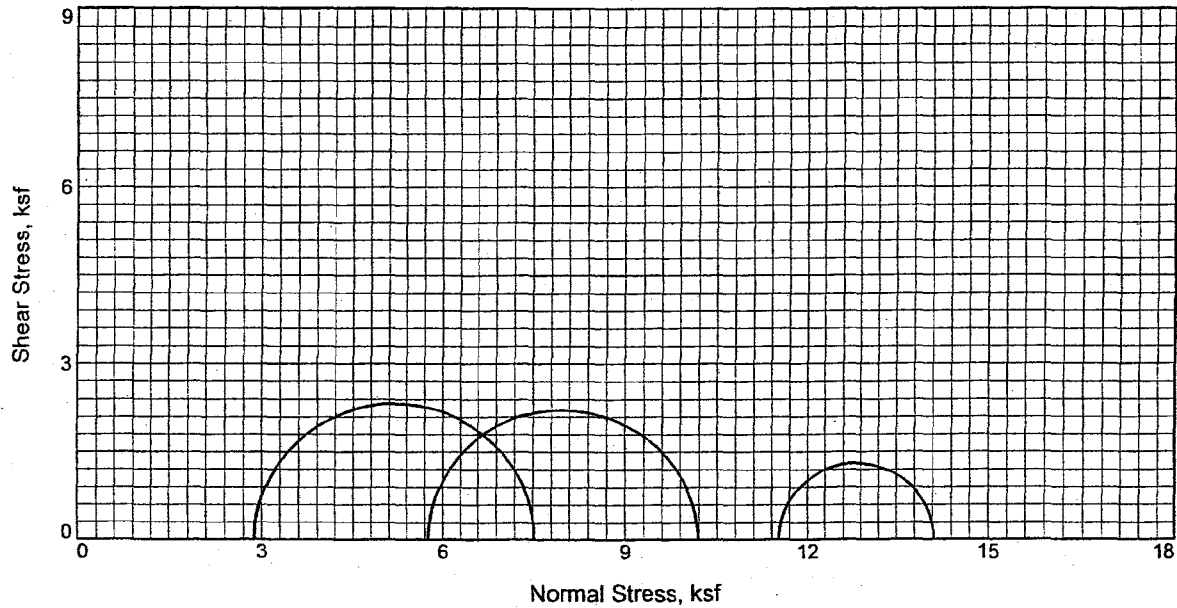

Sample No.	1	2	3	
Initial	Water Content,	23.9	29.4	32.8
	Dry Density, pcf	99.7	92.8	88.4
	Saturation,	96.7	100.0	100.0
	Void Ratio	0.6526	0.7754	0.8651
	Diameter, in.	2.83	2.83	2.84
At Test	Height, in.	6.13	6.14	6.13
	Water Content,	24.7	29.4	32.8
	Dry Density, pcf	99.7	92.8	88.4
	Saturation,	100.0	100.0	100.0
	Void Ratio	0.6526	0.7754	0.8651
Test Parameters	Diameter, in.	2.83	2.83	2.84
	Height, in.	6.13	6.14	6.13
	Strain rate, in./min.	0.02	0.02	0.02
	Back Pressure, ksf	2.9	2.9	2.9
	Cell Pressure, ksf	5.8	8.6	14.4
	Fail. Stress, ksf	4.7	4.4	2.6
	Ult. Stress, ksf			
	$\sigma_1$ Failure, ksf	7.5	10.2	14.1
	$\sigma_3$ Failure, ksf	2.9	5.8	11.5

**Type of Test:**  
Unconsolidated Undrained  
**Sample Type:** undisturbed  
**Description:**

**Assumed Specific Gravity=** 2.64  
**Remarks:**

**Client:** TVA

**Project:** TVA Kingston - Proposed Gypsum Stack

**Location:** NB-85B

**Sample Number:** UD-6, 7 & 8 (UU)

**Depth:** 23'-29'

**Proj. No.:** 3043051021

**Date:**

TRIAXIAL SHEAR TEST REPORT

**MACTEC, INC.**

**Figure** \_\_\_\_\_

**Tested By:** Alexander

**Checked By:** Hamlett

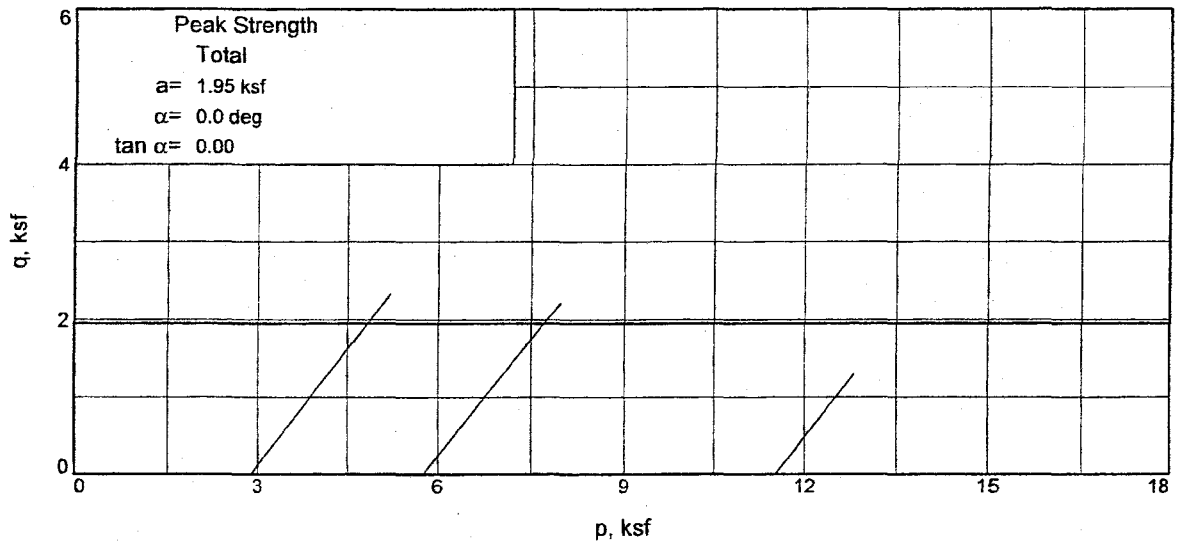
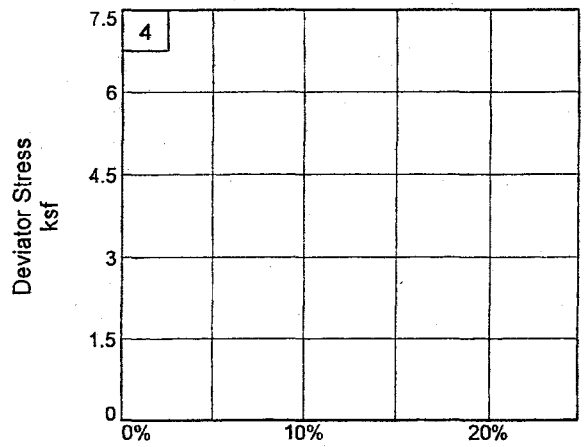
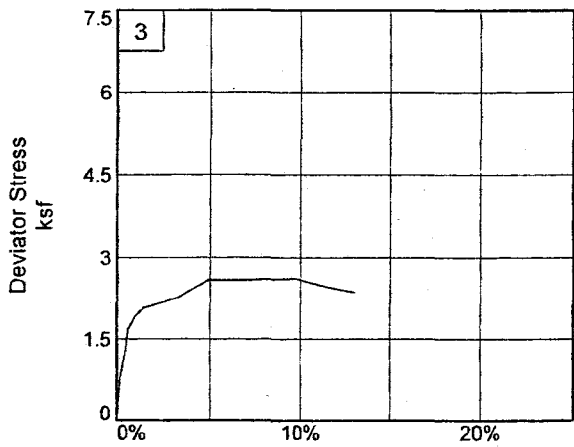
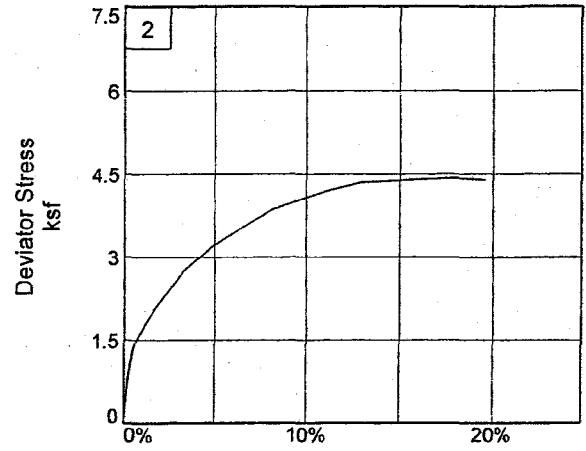
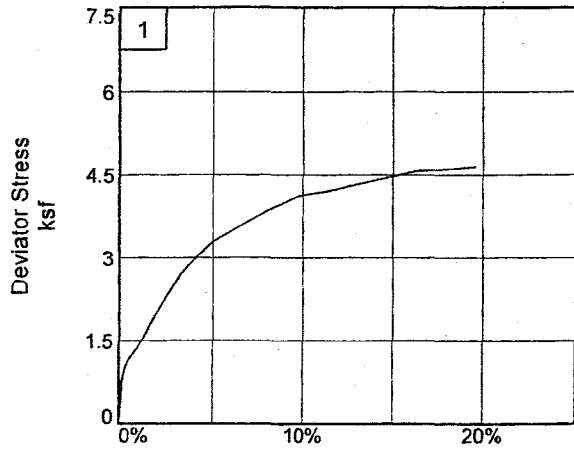

Client: TVA

Project: TVA Kingston - Proposed Gypsum Stack

Location: NB-85B

Depth: 23'-29'

Sample Number: UD-6, 7 & 8 (UU)

Project No.: 3043051021

Figure \_\_\_\_\_

**MACTEC, INC.**

Tested By: Alexander \_\_\_\_\_

Checked By: Hamlett \_\_\_\_\_

**TRIAxIAL COMPRESSION TEST**  
Unconsolidated Undrained

9/13/2005  
10:00 PM

Date:  
 Client: TVA  
 Project: TVA Kingston - Proposed Gypsum Stack  
 Project No.: 3043051021  
 Location: NB-85B  
 Depth: 23'-29' Sample Number: UD-6, 7 & 8 (UU)  
 Description:  
 Remarks:  
 Type of Sample: undisturbed  
 Specific Gravity=2.64 LL= PL= PI=  
 Test Method: COE uniform strain

Parameters for Specimen No. 1			
Specimen Parameter	Initial	Saturated	Final
Moisture content: Moist soil+tare, gms.	1254.700		1366.730
Moisture content: Dry soil+tare, gms.	1012.600		1105.290
Moisture content: Tare, gms.	0.000		93.360
Moisture, %	23.9	24.7	25.8
Moist specimen weight, gms.	1254.7		
Diameter, in.	2.83	2.83	
Area, in. <sup>2</sup>	6.31	6.31	
Height, in.	6.13	6.13	
Net decrease in height, in.		0.00	
Wet Density, pcf	123.6	124.4	
Dry density, pcf	99.7	99.7	
Void ratio	0.6526	0.6526	
Saturation, %	96.7	100.0	

Test Readings for Specimen No. 1

Load ring constant = 0.72 lbs. per input unit  
 Cell pressure = 40.00 psi (5.76 ksf)  
 Back pressure = 20.00 psi (2.88 ksf)  
 Effective confining stress = 2.88 ksf  
 Strain rate, in./min. = 0.02  
 Fail. Stress = 4.65 ksf at reading no. 21

Test Readings for Specimen No. 7

No.	Def. Dial in.	Load Dial	Load lbs.	Strain %	Deviator Stress ksf	Minor Princ. Stress ksf	Major Princ. Stress ksf	1:3 Ratio	P ksf	Q ksf
0	0.0000	0.0	0.0	0.0	0.00	2.88	2.88	1.00		2.88
1	0.0100	46.0	33.1	0.2	0.75	2.88	3.63	1.26		3.26
2	0.0200	62.0	44.6	0.3	1.02	2.88	3.90	1.35		3.39
3	0.0300	69.0	49.7	0.5	1.13	2.88	4.01	1.39		3.44
4	0.0400	74.0	53.3	0.7	1.21	2.88	4.09	1.42		3.48
5	0.0500	79.0	56.9	0.8	1.29	2.88	4.17	1.45		3.52
6	0.0600	84.0	60.5	1.0	1.37	2.88	4.25	1.47		3.56
7	0.0700	89.0	64.1	1.1	1.45	2.88	4.33	1.50		3.60
8	0.0800	96.0	69.1	1.3	1.56	2.88	4.44	1.54		3.66
9	0.0900	103.0	74.2	1.5	1.67	2.88	4.55	1.58		3.71
10	0.1000	111.0	79.9	1.6	1.79	2.88	4.67	1.62		3.78
11	0.2000	170.0	122.4	3.3	2.70	2.88	5.58	1.94		4.23
12	0.3000	209.0	150.5	4.9	3.27	2.88	6.15	2.13		4.51
13	0.4000	233.0	167.8	6.5	3.58	2.88	6.46	2.24		4.67
14	0.5000	257.0	185.0	8.2	3.88	2.88	6.76	2.35		4.82
15	0.6000	278.0	200.2	9.8	4.12	2.88	7.00	2.43		4.94
16	0.7000	289.0	208.1	11.4	4.21	2.88	7.09	2.46		4.98
17	0.8000	303.0	218.2	13.0	4.33	2.88	7.21	2.50		5.05
18	0.9000	317.0	228.2	14.7	4.45	2.88	7.33	2.54		5.10
19	1.0000	332.0	239.0	16.3	4.57	2.88	7.45	2.59		5.16
20	1.1000	341.0	245.5	17.9	4.60	2.88	7.48	2.60		5.18
21	1.2000	352.0	253.4	19.6	4.65	2.88	7.53	2.62		5.21

**Parameters for Specimen No. 2**

Specimen Parameter	Initial	Saturated	Final
Moisture content: Moist soil+tare, gms.	1216.300		650.000
Moisture content: Dry soil+tare, gms.	940.100		500.550
Moisture content: Tare, gms.	0.000		13.930
Moisture, %	29.4	29.4	30.7
Moist specimen weight, gms.	1216.3		
Diameter, in.	2.83	2.83	
Area, in. <sup>2</sup>	6.28	6.28	
Height, in.	6.14	6.14	
Net decrease in height, in.		0.00	
Wet Density, pcf	120.1	120.1	
Dry density, pcf	92.8	92.8	
Void ratio	0.7754	0.7754	
Saturation, %	100.0	100.0	

**Test Readings for Specimen No. 2**

Load ring constant = 0.72 lbs. per input unit  
 Cell pressure = 60.00 psi (8.64 ksf)  
 Back pressure = 20.00 psi (2.88 ksf)  
 Effective confining stress = 5.76 ksf  
 Strain rate, in./min. = 0.02  
 Fail. Stress = 4.43 ksf at reading no. 20

No.	Def. Dial in.	Load Dial	Load lbs.	Strain %	Deviator Stress ksf	Minor Princ. Stress ksf	Major Princ. Stress ksf	1:3 Ratio	P ksf	Q ksf
0	0.0000	0.0	0.0	0.0	0.00	5.76	5.76	1.00		5.76
1	0.0100	39.0	28.1	0.2	0.64	5.76	6.40	1.11		6.08
2	0.0200	65.0	46.8	0.3	1.07	5.76	6.83	1.19		6.29
3	0.0300	82.0	59.0	0.5	1.35	5.76	7.11	1.23		6.43
4	0.0400	91.0	65.5	0.7	1.49	5.76	7.25	1.26		6.51
5	0.0500	98.0	70.6	0.8	1.60	5.76	7.36	1.28		6.56
6	0.0600	103.0	74.2	1.0	1.68	5.76	7.44	1.29		6.60
7	0.0700	110.0	79.2	1.1	1.79	5.76	7.55	1.31		6.66
8	0.0800	115.0	82.8	1.3	1.87	5.76	7.63	1.33		6.70
9	0.0900	120.0	86.4	1.5	1.95	5.76	7.71	1.34		6.74
10	0.1000	126.0	90.7	1.6	2.05	5.76	7.81	1.36		6.78
11	0.2000	172.0	123.8	3.3	2.75	5.76	8.51	1.48		7.13
12	0.3000	204.0	146.9	4.9	3.20	5.76	8.96	1.56		7.36
13	0.4000	229.0	164.9	6.5	3.53	5.76	9.29	1.61		7.53
14	0.5000	254.0	182.9	8.1	3.85	5.76	9.61	1.67		7.69
15	0.6000	272.0	195.8	9.8	4.05	5.76	9.81	1.70		7.79
16	0.7000	289.0	208.1	11.4	4.23	5.76	9.99	1.73		7.87
17	0.8000	303.0	218.2	13.0	4.35	5.76	10.11	1.76		7.93
18	0.9000	311.0	223.9	14.7	4.38	5.76	10.14	1.76		7.95
19	1.0000	319.0	229.7	16.3	4.41	5.76	10.17	1.77		7.96
20	1.1000	327.0	235.4	17.9	4.43	5.76	10.19	1.77		7.98
21	1.2000	331.0	238.3	19.5	4.40	5.76	10.16	1.76		7.96

**Parameters for Specimen No. 3**

Specimen Parameter	Initial	Saturated	Final
Moisture content: Moist soil+tare, gms.	1192.600		565.110
Moisture content: Dry soil+tare, gms.	898.200		423.480
Moisture content: Tare, gms.	0.000		13.360
Moisture, %	32.8	32.8	34.5
Moist specimen weight, gms.	1192.6		
Diameter, in.	2.84	2.84	
Area, in. <sup>2</sup>	6.32	6.32	
Height, in.	6.13	6.13	
Net decrease in height, in.		0.00	
Wet Density, pcf	117.3	117.3	
Dry density, pcf	88.4	88.4	
Void ratio	0.8651	0.8651	
Saturation, %	100.0	100.0	

**Test Readings for Specimen No. 3**

Load ring constant = 0.72 lbs. per input unit  
 Cell pressure = 100.00 psi (14.40 ksf)  
 Back pressure = 20.00 psi (2.88 ksf)  
 Effective confining stress = 11.52 ksf  
 Strain rate, in./min. = 0.02  
 Fail. Stress = 2.61 ksf at reading no. 15

No.	Def. Dial in.	Load Dial	Load lbs.	Strain %	Deviator Stress ksf	Minor Princ. Stress ksf	Major Princ. Stress ksf	1:3 Ratio	P ksf	Q ksf
0	0.0000	0.0	0.0	0.0	0.00	11.52	11.52	1.00		11.52
1	0.0100	48.0	34.6	0.2	0.79	11.52	12.31	1.07		11.91
2	0.0200	65.0	46.8	0.3	1.06	11.52	12.58	1.09		12.05
3	0.0300	78.0	56.2	0.5	1.27	11.52	12.79	1.11		12.16
4	0.0400	103.0	74.2	0.7	1.68	11.52	13.20	1.15		12.36
5	0.0500	110.0	79.2	0.8	1.79	11.52	13.31	1.16		12.42
6	0.0600	117.0	84.2	1.0	1.90	11.52	13.42	1.17		12.47
7	0.0700	121.0	87.1	1.1	1.96	11.52	13.48	1.17		12.50
8	0.0800	124.0	89.3	1.3	2.01	11.52	13.53	1.17		12.52
9	0.0900	128.0	92.2	1.5	2.07	11.52	13.59	1.18		12.56
10	0.1000	129.0	92.9	1.6	2.08	11.52	13.60	1.18		12.56
11	0.2000	142.0	102.2	3.3	2.25	11.52	13.77	1.20		12.65
12	0.3000	165.0	118.8	4.9	2.58	11.52	14.10	1.22		12.81
13	0.4000	168.0	121.0	6.5	2.58	11.52	14.10	1.22		12.81
14	0.5000	172.0	123.8	8.2	2.59	11.52	14.11	1.23		12.82
15	0.6000	176.0	126.7	9.8	2.61	11.52	14.13	1.23		12.82
16	0.7000	169.0	121.7	11.4	2.46	11.52	13.98	1.21		12.75
17	0.8000	165.0	118.8	13.1	2.35	11.52	13.87	1.20		12.70

**CONSOLIDATED UNDRAINED TRIAXIAL COMPRESSION TEST RESULTS**

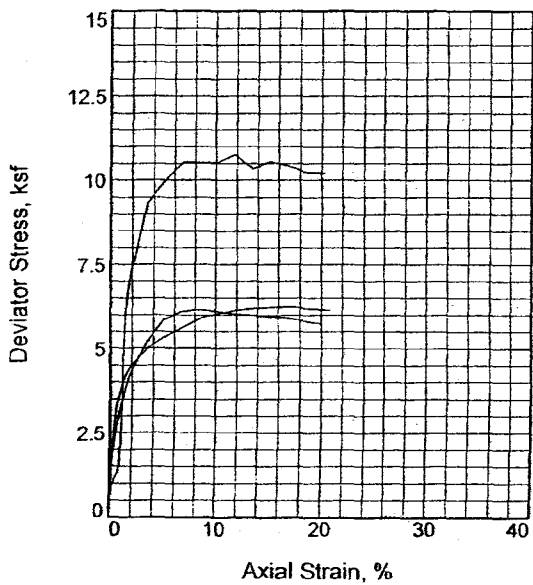
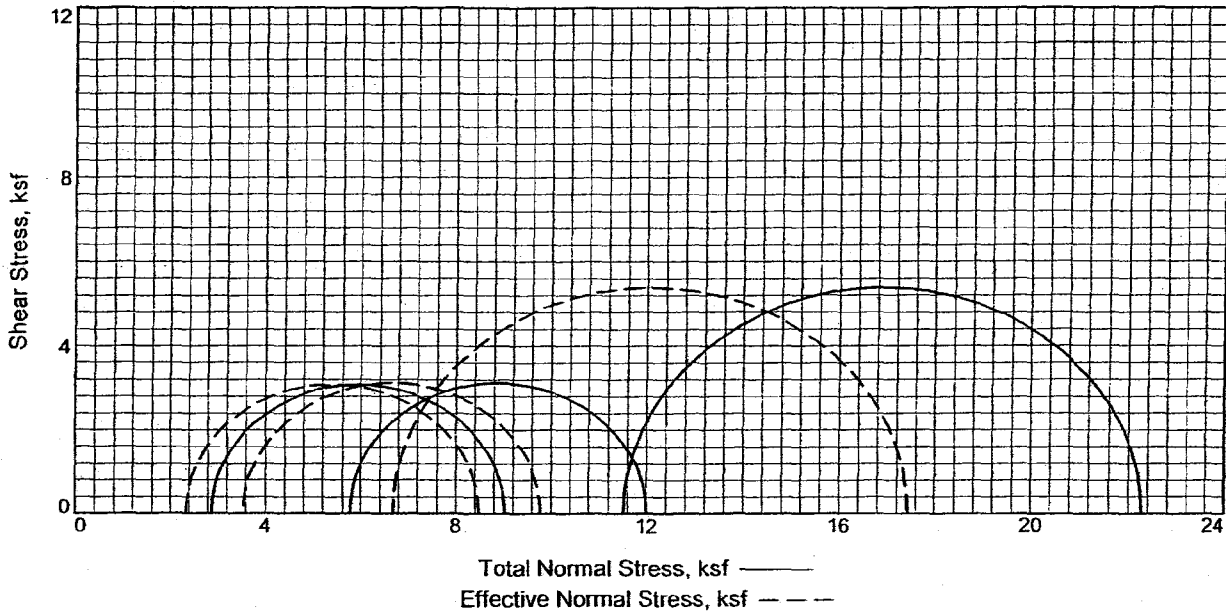

Sample No.	1	2	3	
Initial	Water Content,	29.2	26.7	32.3
	Dry Density, pcf	89.0	90.1	83.7
	Saturation,	91.2	85.8	88.8
	Void Ratio	0.8376	0.8153	0.9535
	Diameter, in.	2.84	2.84	2.81
	Height, in.	6.02	5.85	6.07
At Test	Water Content,	31.4	28.0	30.7
	Dry Density, pcf	89.8	94.4	90.7
	Saturation,	100.0	100.0	100.0
	Void Ratio	0.8221	0.7325	0.8037
	Diameter, in.	2.84	2.80	2.74
	Height, in.	6.00	5.76	5.91
Strain rate, in./min.	0.02	0.02	0.02	
Back Pressure, ksf	2.9	2.9	2.9	
Cell Pressure, ksf	5.8	8.6	14.4	
Fail. Stress, ksf	6.2	6.2	10.8	
Total Pore Pr., ksf	3.4	5.1	7.7	
Ult. Stress, ksf				
Total Pore Pr., ksf				
$\bar{\sigma}_1$ Failure, ksf	8.5	9.8	17.4	
$\bar{\sigma}_3$ Failure, ksf	2.3	3.5	6.7	

**Type of Test:**

CU with Pore Pressures

**Sample Type:** undisturbed

**Description:** Brown to red brown elastic silt

LL= 81

PL= 42

PI= 39

**Specific Gravity:** 2.62

**Remarks:** MH

**Client:** TVA

**Project:** TVA Kingston - Proposed Gypsum Stack

**Location:** NB-18

**Sample Number:** UD-1, 3 & 4 (CU)

**Depth:** 6.5'-18.5'

**Proj. No.:** 3043051021

**Date:**

TRIAXIAL SHEAR TEST REPORT

**MACTEC, INC.**

Figure \_\_\_\_\_

Tested By: Alexander

Checked By: Hamlett



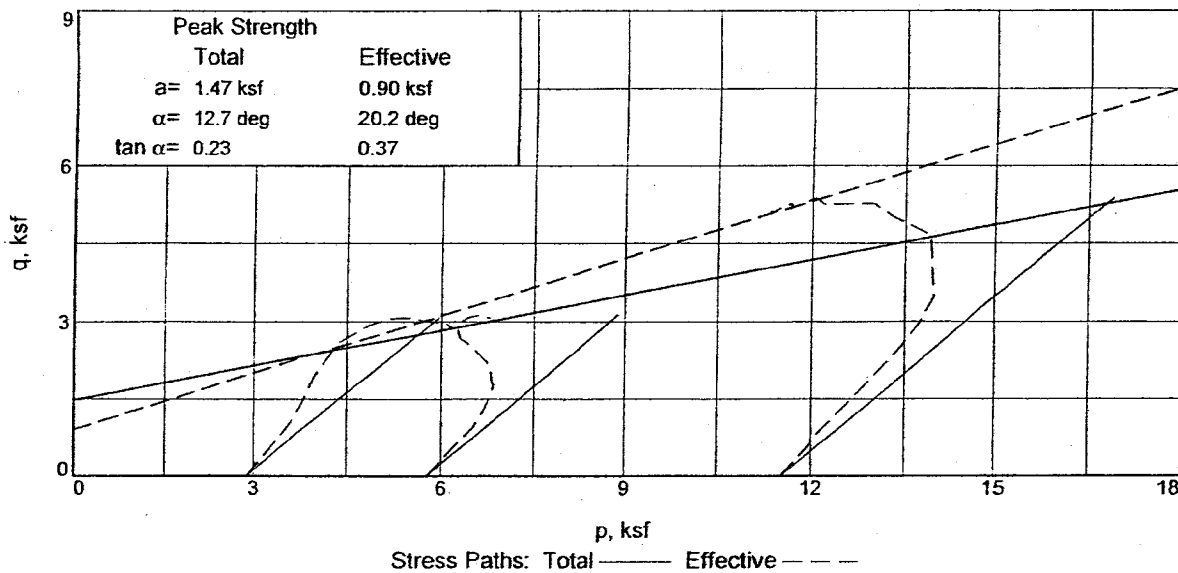
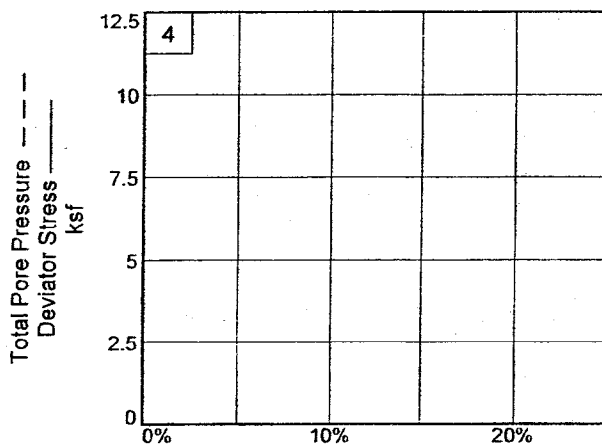
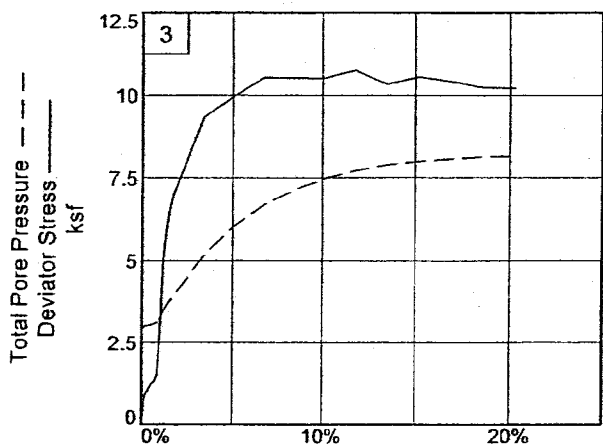
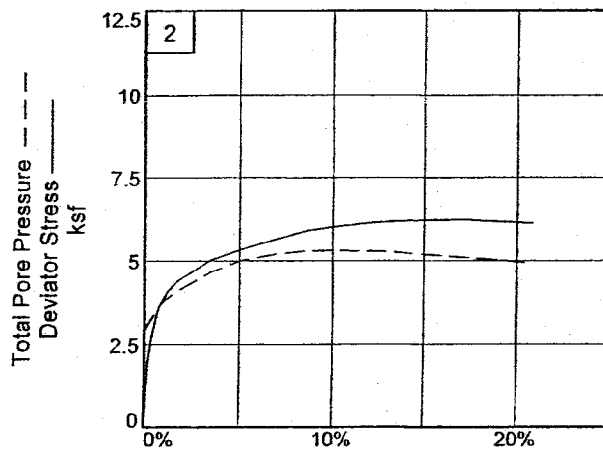
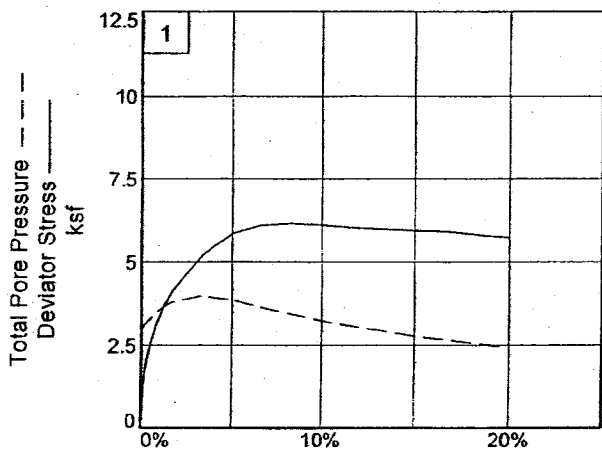

Client: TVA

Project: TVA Kingston - Proposed Gypsum Stack

Location: NB-18

Depth: 6.5'-18.5'

Sample Number: UD-1, 3 & 4 (CU)

Project No.: 3043051021

Figure \_\_\_\_\_

**MACTEC, INC.**

Tested By: Alexander \_\_\_\_\_

Checked By: Hamlett \_\_\_\_\_



Test Results for Specimen No. 7

No.	Def. Dial in.	Load Dial	Load lbs.	Strain %	Deviator Stress ksf	Minor Eff. Stress ksf	Major Eff. Stress ksf	1:3 Ratio	Pore Press. psi	P ksf	Q ksf
0	0.0000	0.0	0.0	0.0	0.00	2.88	2.88	1.00	20.00	2.88	0.00
1	0.0100	97.0	69.8	0.2	1.59	2.65	4.24	1.60	21.60	3.44	0.79
2	0.0200	132.0	95.0	0.3	2.16	2.55	4.71	1.85	22.30	3.63	1.08
3	0.0300	156.0	112.3	0.5	2.55	2.45	5.00	2.04	23.00	3.72	1.27
4	0.0400	174.0	125.3	0.7	2.84	2.38	5.21	2.19	23.50	3.79	1.42
5	0.0500	192.0	138.2	0.8	3.13	2.29	5.41	2.36	24.10	3.85	1.56
6	0.0600	206.0	148.3	1.0	3.35	2.22	5.57	2.51	24.60	3.89	1.67
7	0.0700	219.0	157.7	1.2	3.55	2.15	5.70	2.66	25.10	3.92	1.78
8	0.0800	232.0	167.0	1.3	3.76	2.09	5.85	2.80	25.50	3.97	1.88
9	0.0900	243.0	175.0	1.5	3.93	2.03	5.96	2.93	25.90	3.99	1.96
10	0.1000	255.0	183.6	1.7	4.12	1.99	6.10	3.07	26.20	4.05	2.06
11	0.2000	327.0	235.4	3.3	5.19	1.79	6.97	3.91	27.60	4.38	2.59
12	0.3000	375.0	270.0	5.0	5.85	1.92	7.76	4.05	26.70	4.84	2.92
13	0.4000	398.0	286.6	6.7	6.10	2.13	8.23	3.86	25.20	5.18	3.05
14	0.5000	409.0	294.5	8.3	6.15	2.33	8.49	3.64	23.80	5.41	3.08
15	0.6000	414.0	298.1	10.0	6.12	2.53	8.65	3.41	22.40	5.59	3.06
16	0.7000	416.0	299.5	11.7	6.03	2.69	8.72	3.24	21.30	5.71	3.02
17	0.8000	421.0	303.1	13.3	5.99	2.85	8.84	3.10	20.20	5.85	2.99
18	0.9070	426.0	306.7	15.1	5.94	3.01	8.95	2.97	19.10	5.98	2.97
19	1.0000	433.0	311.8	16.7	5.92	3.11	9.03	2.90	18.40	6.07	2.96
20	1.1460	435.0	313.2	19.1	5.78	3.27	9.05	2.77	17.30	6.16	2.89
21	1.2017	437.0	314.6	20.0	5.74	3.34	9.08	2.72	16.80	6.21	2.87

PARAMETERS FOR SPECIMEN NO. 2

Specimen Parameter	Initial	Saturated	Consolidated	Final
Moisture content: Moist soil+tare, gms.	1113.500			1136.000
Moisture content: Dry soil+tare, gms.	878.900			892.950
Moisture content: Tare, gms.	0.000			13.930
Moisture, %	26.7	31.1	28.0	27.7
Moist specimen weight, gms.	1113.5			
Diameter, in.	2.84	2.84	2.80	
Area, in. <sup>2</sup>	6.35	6.35	6.15	
Height, in.	5.85	5.85	5.76	
Net decrease in height, in.		0.00	0.09	
Wet Density, pcf	114.1	118.1	120.8	
Dry density, pcf	90.1	90.1	94.4	
Void ratio	0.8153	0.8153	0.7325	
Saturation, %	85.8	100.0	100.0	

TEST RESULTS FOR SPECIMEN NO. 2

Load ring constant = 0.72 lbs. per input unit  
 Consolidation cell pressure = 60.00 psi (8.64 ksf)  
 Consolidation back pressure = 20.00 psi (2.88 ksf)  
 Consolidation effective confining stress = 5.76 ksf  
 Strain rate, in./min. = 0.02  
 Fail. Stress = 6.24 ksf at reading no. 19

No.	Def. Dial in.	Load Dial	Load lbs.	Strain %	Deviator Stress ksf	Minor Eff. Stress ksf	Major Eff. Stress ksf	1:3 Ratio	Pore Press. psi	P ksf	Q ksf
0	0.0000	0.0	0.0	0.0	0.00	5.76	5.76	1.00	20.00	5.76	0.00
1	0.0100	115.0	82.8	0.2	1.93	5.54	7.48	1.35	21.50	6.51	0.97
2	0.0200	155.0	111.6	0.3	2.60	5.39	7.99	1.48	22.60	6.69	1.30
3	0.0300	186.0	133.9	0.5	3.12	5.23	8.35	1.60	23.70	6.79	1.56
4	0.0400	209.0	150.5	0.7	3.50	5.08	8.58	1.69	24.70	6.83	1.75
5	0.0500	222.0	159.8	0.9	3.71	4.95	8.66	1.75	25.60	6.81	1.85
6	0.0600	235.0	169.2	1.0	3.92	4.84	8.76	1.81	26.40	6.80	1.96
7	0.0700	245.0	176.4	1.2	4.08	4.75	8.83	1.86	27.00	6.79	2.04
8	0.0800	252.0	181.4	1.4	4.19	4.68	8.87	1.89	27.50	6.77	2.09
9	0.0900	259.0	186.5	1.6	4.30	4.61	8.90	1.93	28.00	6.76	2.15
10	0.1000	266.0	191.5	1.7	4.40	4.54	8.94	1.97	28.50	6.74	2.20
11	0.2000	309.0	222.5	3.5	5.03	3.97	9.00	2.26	32.40	6.49	2.51
12	0.3000	336.0	241.9	5.2	5.37	3.61	8.98	2.48	34.90	6.30	2.68
13	0.4000	360.0	259.2	6.9	5.65	3.44	9.09	2.64	36.10	6.26	2.82
14	0.5000	384.0	276.5	8.7	5.91	3.34	9.25	2.77	36.80	6.30	2.95
15	0.6000	400.0	288.0	10.4	6.04	3.33	9.37	2.82	36.90	6.35	3.02
16	0.7000	415.0	298.8	12.1	6.14	3.34	9.48	2.84	36.80	6.41	3.07
17	0.8000	427.0	307.4	13.9	6.20	3.40	9.59	2.82	36.40	6.50	3.10
18	0.9000	438.0	315.4	15.6	6.23	3.47	9.70	2.79	35.90	6.58	3.11
19	1.0000	448.0	322.6	17.3	6.24	3.54	9.78	2.76	35.40	6.66	3.12
20	1.1000	453.0	326.2	19.1	6.18	3.61	9.79	2.71	34.90	6.70	3.09
21	1.2000	460.0	331.2	20.8	6.14	3.72	9.85	2.65	34.20	6.78	3.07

**Parameters for Specimen No. 3**

Specimen Parameter	Initial	Saturated	Consolidated	Final
Moisture content: Moist soil+tare, gms.	1095.000			1095.900
Moisture content: Dry soil+tare, gms.	827.600			841.350
Moisture content: Tare, gms.	0.000			13.570
Moisture, %	32.3	36.4	30.7	30.8
Moist specimen weight, gms.	1095.0			
Diameter, in.	2.81	2.81	2.74	
Area, in. <sup>2</sup>	6.20	6.20	5.88	
Height, in.	6.07	6.07	5.91	
Net decrease in height, in.		0.00	0.16	
Wet Density, pcf	110.8	114.2	118.5	
Dry density, pcf	83.7	83.7	90.7	
Void ratio	0.9535	0.9535	0.8037	
Saturation, %	88.8	100.0	100.0	

**Test Readings for Specimen No. 3**

Load ring constant = 0.72 lbs. per input unit  
 Consolidation cell pressure = 100.00 psi (14.40 ksf)  
 Consolidation back pressure = 20.00 psi (2.88 ksf)  
 Consolidation effective confining stress = 11.52 ksf  
 Strain rate, in./min. = 0.02  
 Fail. Stress = 10.76 ksf at reading no. 16

No.	Def. Dial in.	Load Dial	Load lbs.	Strain %	Deviator Stress ksf	Minor Eff. Stress ksf	Major Eff. Stress ksf	1:3 Ratio	Pore Press. psi	P ksf	Q ksf
0	0.0000	0.0	0.0	0.0	0.00	11.52	11.52	1.00	20.00	11.52	0.00
1	0.0100	52.0	37.4	0.2	0.92	11.40	12.32	1.08	20.80	11.86	0.46
2	0.0200	59.0	42.5	0.3	1.04	11.39	12.43	1.09	20.90	11.91	0.52
3	0.0300	69.0	49.7	0.5	1.21	11.36	12.57	1.11	21.10	11.97	0.61
4	0.0400	75.0	54.0	0.7	1.31	11.33	12.65	1.12	21.30	11.99	0.66
5	0.0500	86.0	61.9	0.8	1.50	11.29	12.79	1.13	21.60	12.04	0.75
6	0.0600	168.0	121.0	1.0	2.93	11.16	14.09	1.26	22.50	12.63	1.47
7	0.0700	289.0	208.1	1.2	5.04	10.93	15.97	1.46	24.10	13.45	2.52
8	0.0800	342.0	246.2	1.4	5.95	10.77	16.72	1.55	25.20	13.75	2.97
9	0.0900	376.0	270.7	1.5	6.53	10.63	17.16	1.61	26.20	13.89	3.27
10	0.1000	401.0	288.7	1.7	6.95	10.51	17.46	1.66	27.00	13.99	3.48
11	0.2000	548.0	394.6	3.4	9.34	9.26	18.60	2.01	35.70	13.93	4.67
12	0.3000	596.0	429.1	5.1	9.98	8.35	18.33	2.19	42.00	13.34	4.99
13	0.4000	641.0	461.5	6.8	10.54	7.72	18.26	2.37	46.40	12.99	5.27
14	0.5000	652.0	469.4	8.5	10.53	7.27	17.80	2.45	49.50	12.54	5.26
15	0.6000	664.0	478.1	10.1	10.52	6.93	17.45	2.52	51.90	12.19	5.26
16	0.7000	692.0	498.2	11.8	10.76	6.68	17.44	2.61	53.60	12.06	5.38
17	0.8000	678.0	488.2	13.5	10.34	6.49	16.83	2.59	54.90	11.66	5.17
18	0.9000	706.0	508.3	15.2	10.56	6.39	16.95	2.65	55.60	11.67	5.28
19	1.0000	711.0	511.9	16.9	10.42	6.32	16.74	2.65	56.10	11.53	5.21
20	1.1000	713.0	513.4	18.6	10.24	6.26	16.50	2.63	56.50	11.38	5.12
21	1.2000	727.0	523.4	20.3	10.22	6.24	16.46	2.64	56.70	11.35	5.11

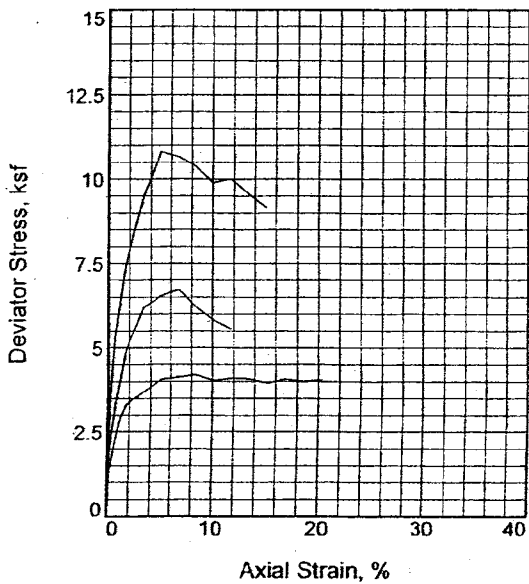
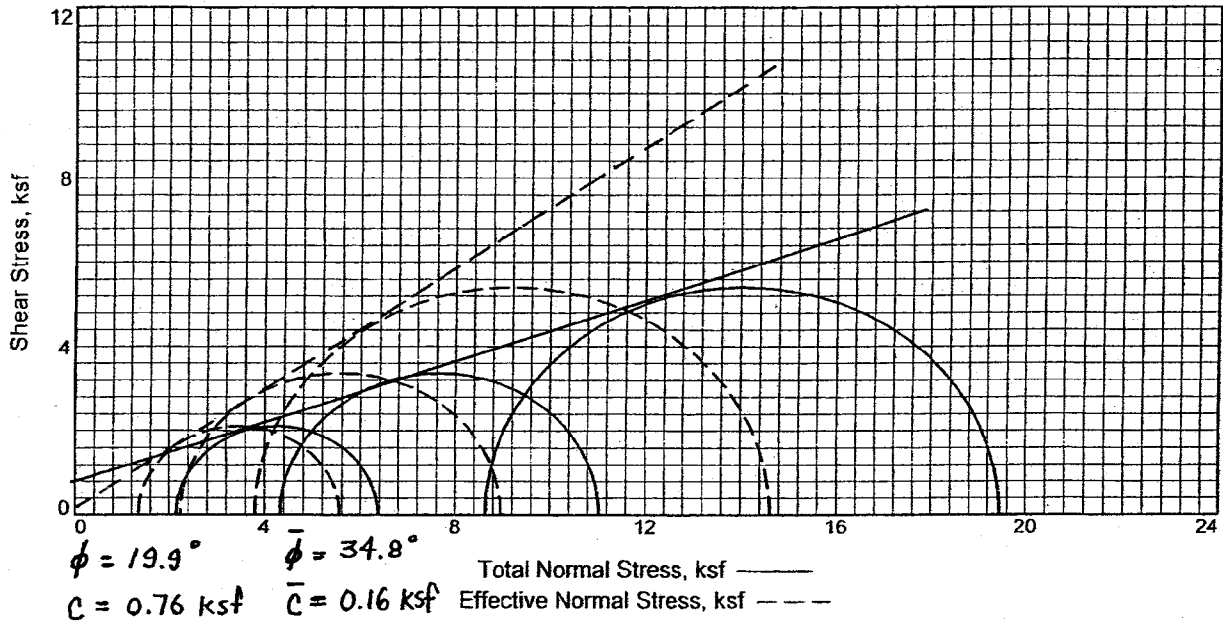

Sample No.		1	2	3
Initial	Water Content,	27.5	29.6	29.4
	Dry Density, pcf	93.0	89.8	92.7
	Saturation,	93.8	93.1	99.6
	Void Ratio	0.7787	0.8428	0.7837
	Diameter, in.	2.85	2.84	2.83
Height, in.		5.98	6.08	6.11
At Test	Water Content,	26.5	27.5	25.0
	Dry Density, pcf	97.2	95.6	99.5
	Saturation,	100.0	100.0	100.0
	Void Ratio	0.7027	0.7299	0.6629
	Diameter, in.	2.81	2.78	2.76
Height, in.		5.89	5.96	5.97
Strain rate, in./min.		0.02	0.02	0.02
Back Pressure, ksf		4.3	4.3	4.3
Cell Pressure, ksf		6.5	8.6	13.0
Fail. Stress, ksf		4.2	6.7	10.8
Total Pore Pr., ksf		5.1	6.4	9.2
Ult. Stress, ksf				
Total Pore Pr., ksf				
$\bar{\sigma}_1$ Failure, ksf		5.6	9.0	14.6
$\bar{\sigma}_3$ Failure, ksf		1.4	2.2	3.8

**Type of Test:**  
 CU with Pore Pressures  
**Sample Type:** undisturbed  
**Description:** Brown fat clay with sand  
 LL= 53      PL= 28      PI= 25  
 Specific Gravity= 2.65  
 Remarks: CH

**Client:** TVA  
**Project:** TVA Kingston - Proposed Gypsum Stack  
**Location:** NB-21A  
**Sample Number:** UD-1, 2 & 3 (CU)      **Depth:** 15'-23'  
**Proj. No.:** 3043051021      **Date:**

TRIAXIAL SHEAR TEST REPORT  
**MACTEC, INC.**

Figure \_\_\_\_\_

Tested By: Alexander \_\_\_\_\_ Checked By: Hamlett \_\_\_\_\_

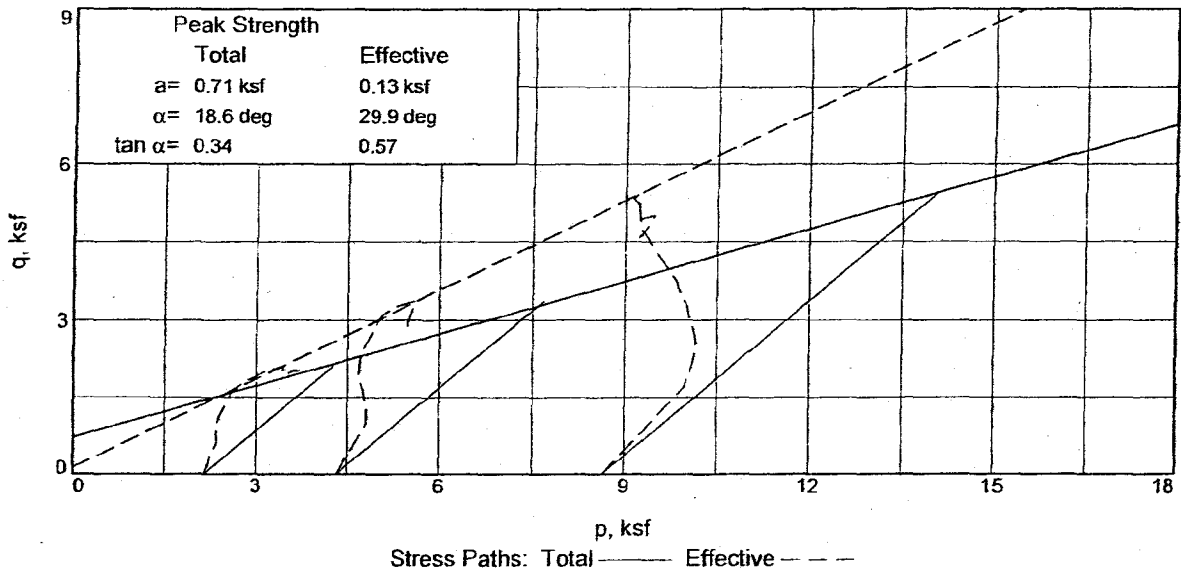
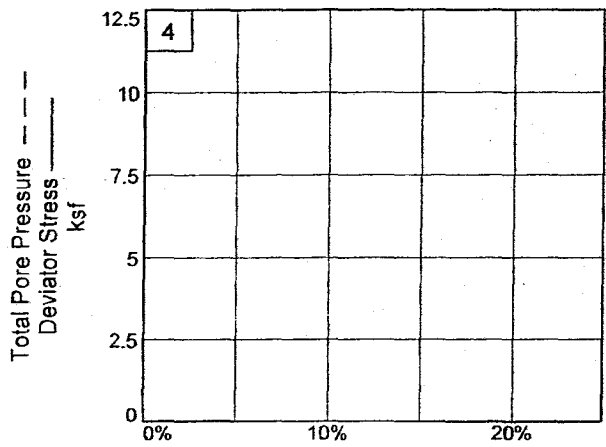
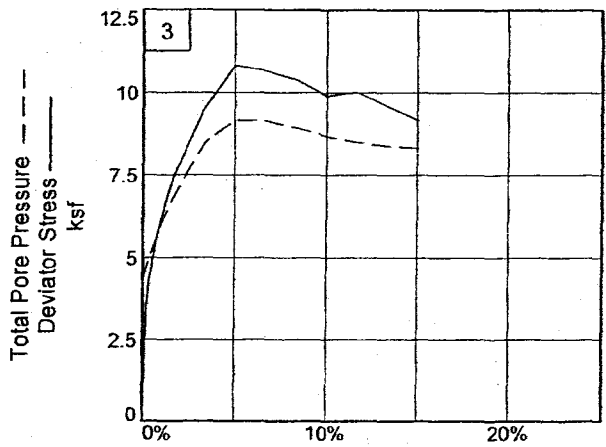
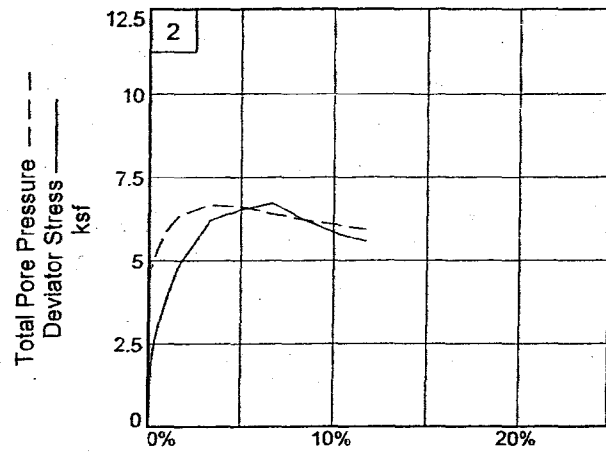
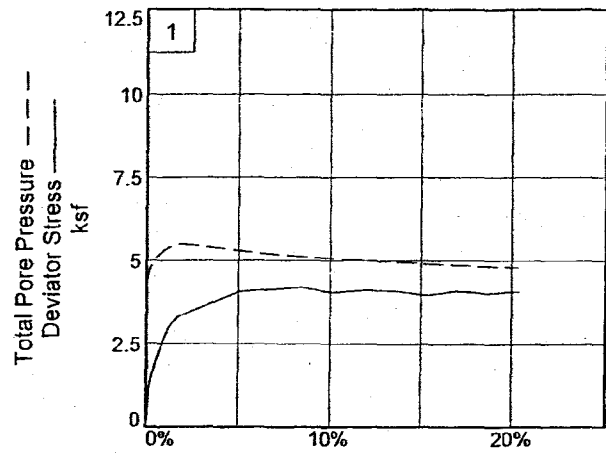

Client: TVA

Project: TVA Kingston - Proposed Gypsum Stack

Location: NB-21A

Depth: 15'-23'

Sample Number: UD-1, 2 & 3 (CU)

Project No.: 3043051021

Figure \_\_\_\_\_

**MACTEC, INC.**

Tested By: Alexander \_\_\_\_\_

Checked By: Hamlett \_\_\_\_\_

**TRIAxIAL COMPRESSION TEST**  
CU with Pore Pressures

9/13/2005  
9:21 PM

Date:  
 Client: TVA  
 Project: TVA Kingston - Proposed Gypsum Stack  
 Project No.: 3043051021  
 Location: NB-21A  
 Depth: 15'-23' Sample Number: UD-1, 2 & 3 (CU)  
 Description:  
 Remarks:  
 Type of Sample: undisturbed  
 Specific Gravity=2.65      LL=53      PL=28      PI=25  
 Test Method: COE uniform strain

**Parameters for Specimen No. 1**

Specimen Parameter	Initial	Saturated	Consolidated	Final
Moisture content: Moist soil+tare, gms.	1190.700			1289.490
Moisture content: Dry soil+tare, gms.	933.520			1021.630
Moisture content: Tare, gms.	0.000			88.110
Moisture, %	27.5	29.4	26.5	28.7
Moist specimen weight, gms.	1190.7			
Diameter, in.	2.85	2.85	2.81	
Area, in. <sup>2</sup>	6.39	6.39	6.21	
Height, in.	5.98	5.98	5.89	
Net decrease in height, in.		0.00	0.09	
Wet Density, pcf	118.6	120.3	122.9	
Dry density, pcf	93.0	93.0	97.2	
Void ratio	0.7787	0.7787	0.7027	
Saturation, %	93.8	100.0	100.0	

**Readings for Specimen No. 1**

Load ring constant = 0.72 lbs. per input unit  
 Consolidation cell pressure = 45.00 psi (6.48 ksf)  
 Consolidation back pressure = 30.00 psi (4.32 ksf)  
 Consolidation effective confining stress = 2.16 ksf  
 Strain rate, in./min. = 0.02  
 Fail. Stress = 4.20 ksf at reading no. 14



No.	Def. Dial in.	Load Dial	Load lbs.	Strain %	Deviator Stress ksf	Minor Eff. Stress ksf	Major Eff. Stress ksf	1:3 Ratio	Pore Press. psi	P ksf	Q ksf
0	0.0000	0.0	0.0	0.0	0.00	2.16	2.16	1.00	30.00	2.16	0.00
1	0.0100	74.0	53.3	0.2	1.23	1.74	2.98	1.71	32.90	2.36	0.62
2	0.0200	98.0	70.6	0.3	1.63	1.54	3.17	2.06	34.30	2.36	0.82
3	0.0300	120.0	86.4	0.5	1.99	1.37	3.36	2.46	35.50	2.36	1.00
4	0.0400	138.0	99.4	0.7	2.29	1.27	3.56	2.81	36.20	2.41	1.14
5	0.0500	153.0	110.2	0.8	2.53	1.20	3.73	3.12	36.70	2.46	1.27
6	0.0600	166.0	119.5	1.0	2.74	1.14	3.88	3.41	37.10	2.51	1.37
7	0.0700	179.0	128.9	1.2	2.95	1.08	4.03	3.73	37.50	2.56	1.48
8	0.0800	187.0	134.6	1.4	3.08	1.05	4.13	3.93	37.70	2.59	1.54
9	0.0900	194.0	139.7	1.5	3.19	1.01	4.20	4.16	38.00	2.60	1.60
10	0.1000	201.0	144.7	1.7	3.30	0.98	4.28	4.37	38.20	2.63	1.65
11	0.2000	229.0	164.9	3.4	3.69	1.05	4.75	4.51	37.70	2.90	1.85
12	0.3000	256.0	184.3	5.1	4.06	1.18	5.24	4.44	36.80	3.21	2.03
13	0.4000	265.0	190.8	6.8	4.12	1.28	5.41	4.22	36.10	3.34	2.06
14	0.5000	275.0	198.0	8.5	4.20	1.35	5.56	4.10	35.60	3.45	2.10
15	0.6000	269.0	193.7	10.2	4.03	1.41	5.45	3.86	35.20	3.43	2.02
16	0.7000	279.0	200.9	11.9	4.11	1.47	5.57	3.80	34.80	3.52	2.05
17	0.8000	283.0	203.8	13.6	4.08	1.53	5.61	3.68	34.40	3.57	2.04
18	0.9000	279.0	200.9	15.3	3.95	1.57	5.52	3.52	34.10	3.54	1.97
19	1.0000	294.0	211.7	17.0	4.08	1.63	5.70	3.51	33.70	3.67	2.04
20	1.1000	295.0	212.4	18.7	4.01	1.66	5.66	3.42	33.50	3.66	2.00
21	1.2000	305.0	219.6	20.4	4.06	1.70	5.76	3.39	33.20	3.73	2.03

**Parameters for Specimen No. 2**

Specimen Parameter	Initial	Saturated	Consolidated	Final
Moisture content: Moist soil+tare, gms.	1178.700			1201.320
Moisture content: Dry soil+tare, gms.	909.500			923.300
Moisture content: Tare, gms.	0.000			13.570
Moisture, %	29.6	31.8	27.5	30.6
Moist specimen weight, gms.	1178.7			
Diameter, in.	2.84	2.84	2.78	
Area, in. <sup>2</sup>	6.34	6.34	6.08	
Height, in.	6.08	6.08	5.96	
Net decrease in height, in.		0.00	0.13	
Wet Density, pcf	116.3	118.3	122.0	
Dry density, pcf	89.8	89.8	95.6	
Void ratio	0.8428	0.8428	0.7299	
Saturation, %	93.1	100.0	100.0	

**Readings for Specimen No. 2**

Load ring constant = 0.72 lbs. per input unit  
 Consolidation cell pressure = 60.00 psi (8.64 ksf)  
 Consolidation back pressure = 30.00 psi (4.32 ksf)  
 Consolidation effective confining stress = 4.32 ksf  
 Strain rate, in./min. = 0.02  
 Fail. Stress = 6.73 ksf at reading no. 13

No.	Def. Dial in.	Load Dial	Load lbs.	Strain %	Deviator Stress ksf	Minor Eff. Stress ksf	Major Eff. Stress ksf	1:3 Ratio	Pore Press. psi	P ksf	Q ksf
0	0.0000	0.0	0.0	0.0	0.00	4.32	4.32	1.00	30.00	4.32	0.00
1	0.0100	114.0	82.1	0.2	1.94	3.83	5.77	1.51	33.40	4.80	0.97
2	0.0200	149.0	107.3	0.3	2.53	3.54	6.07	1.71	35.40	4.81	1.27
3	0.0300	173.0	124.6	0.5	2.93	3.30	6.23	1.89	37.10	4.77	1.47
4	0.0400	194.0	139.7	0.7	3.29	3.10	6.38	2.06	38.50	4.74	1.64
5	0.0500	211.0	151.9	0.8	3.57	2.92	6.49	2.22	39.70	4.71	1.78
6	0.0600	229.0	164.9	1.0	3.87	2.75	6.62	2.41	40.90	4.68	1.93
7	0.0700	246.0	177.1	1.2	4.15	2.62	6.77	2.58	41.80	4.69	2.07
8	0.0800	261.0	187.9	1.3	4.39	2.51	6.90	2.75	42.60	4.70	2.20
9	0.0900	277.0	199.4	1.5	4.65	2.40	7.06	2.93	43.30	4.73	2.33
10	0.1000	292.0	210.2	1.7	4.90	2.30	7.20	3.12	44.00	4.75	2.45
11	0.2000	376.0	270.7	3.4	6.20	1.97	8.17	4.14	46.30	5.07	3.10
12	0.3000	403.0	290.2	5.0	6.53	2.03	8.56	4.21	45.90	5.29	3.26
13	0.4000	423.0	304.6	6.7	6.73	2.25	8.97	4.00	44.40	5.61	3.36
14	0.5000	399.0	287.3	8.4	6.23	2.42	8.65	3.58	43.20	5.54	3.12
15	0.6000	380.0	273.6	10.1	5.83	2.56	8.39	3.27	42.20	5.48	2.91
16	0.7000	370.0	266.4	11.7	5.57	2.71	8.27	3.06	41.20	5.49	2.78

**PROPERTIES OF SPECIMEN NO. 2**

Specimen Parameter	Initial	Saturated	Consolidated	Final
Moisture content: Moist soil+tare, gms.	1208.200			1209.110
Moisture content: Dry soil+tare, gms.	933.400			946.980
Moisture content: Tare, gms.	0.000			13.380
Moisture, %	29.4	29.6	25.0	28.1
Moist specimen weight, gms.	1208.2			
Diameter, in.	2.83	2.83	2.76	
Area, in. <sup>2</sup>	6.28	6.28	5.99	
Height, in.	6.11	6.11	5.97	
Net decrease in height, in.		0.00	0.14	
Wet Density, pcf	120.1	120.2	124.4	
Dry density, pcf	92.7	92.7	99.5	
Void ratio	0.7837	0.7837	0.6629	
Saturation, %	99.6	100.0	100.0	

**TESTING DATA - SPECIMEN NO. 2**

Load ring constant = 0.72 lbs. per input unit  
 Consolidation cell pressure = 90.00 psi (12.96 ksf)  
 Consolidation back pressure = 30.00 psi (4.32 ksf)  
 Consolidation effective confining stress = 8.64 ksf  
 Strain rate, in./min. = 0.02  
 Fail. Stress = 10.82 ksf at reading no. 12

No.	Def. Dial in.	Load Dial	Load lbs.	Strain %	Deviator Stress ksf	Minor Eff. Stress ksf	Major Eff. Stress ksf	1:3 Ratio	Pore Press. psi	P ksf	Q ksf
0	0.0000	0.0	0.0	0.0	0.00	8.64	8.64	1.00	30.00	8.64	0.00
1	0.0100	197.0	141.8	0.2	3.40	8.27	11.67	1.41	32.60	9.97	1.70
2	0.0200	249.0	179.3	0.3	4.30	7.96	12.26	1.54	34.70	10.11	2.15
3	0.0300	285.0	205.2	0.5	4.91	7.70	12.61	1.64	36.50	10.16	2.45
4	0.0400	312.0	224.6	0.7	5.36	7.46	12.82	1.72	38.20	10.14	2.68
5	0.0500	336.0	241.9	0.8	5.77	7.21	12.98	1.80	39.90	10.10	2.88
6	0.0600	359.0	258.5	1.0	6.15	6.97	13.12	1.88	41.60	10.05	3.08
7	0.0700	383.0	275.8	1.2	6.55	6.74	13.29	1.97	43.20	10.02	3.28
8	0.0800	402.0	289.4	1.3	6.87	6.51	13.37	2.05	44.80	9.94	3.43
9	0.0900	421.0	303.1	1.5	7.18	6.28	13.46	2.14	46.40	9.87	3.59
10	0.1000	439.0	316.1	1.7	7.47	6.11	13.58	2.22	47.60	9.84	3.74
11	0.2000	570.0	410.4	3.4	9.54	4.48	14.02	3.13	58.90	9.25	4.77
12	0.3000	658.0	473.8	5.0	10.82	3.80	14.62	3.85	63.60	9.21	5.41
13	0.4000	660.0	475.2	6.7	10.66	3.80	14.46	3.80	63.60	9.13	5.33
14	0.5000	655.0	471.6	8.4	10.39	4.03	14.42	3.58	62.00	9.23	5.19
15	0.6000	635.0	457.2	10.1	9.89	4.29	14.18	3.30	60.20	9.23	4.94
16	0.7000	655.0	471.6	11.7	10.01	4.46	14.47	3.24	59.00	9.47	5.00
17	0.8000	638.0	459.4	13.4	9.56	4.58	14.14	3.09	58.20	9.36	4.78
18	0.9000	623.0	448.6	15.1	9.16	4.64	13.80	2.98	57.80	9.22	4.58

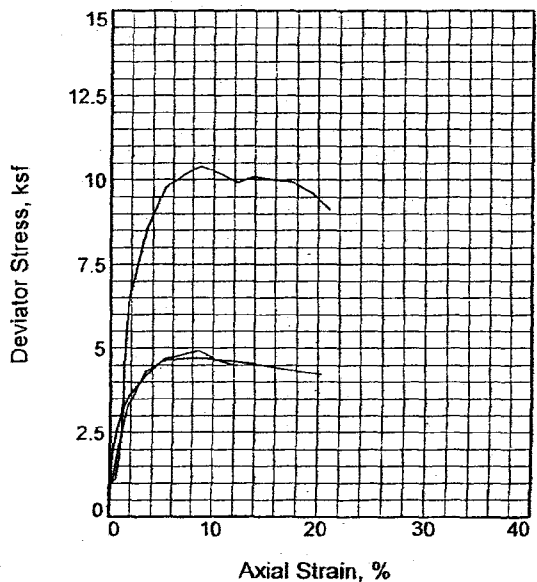
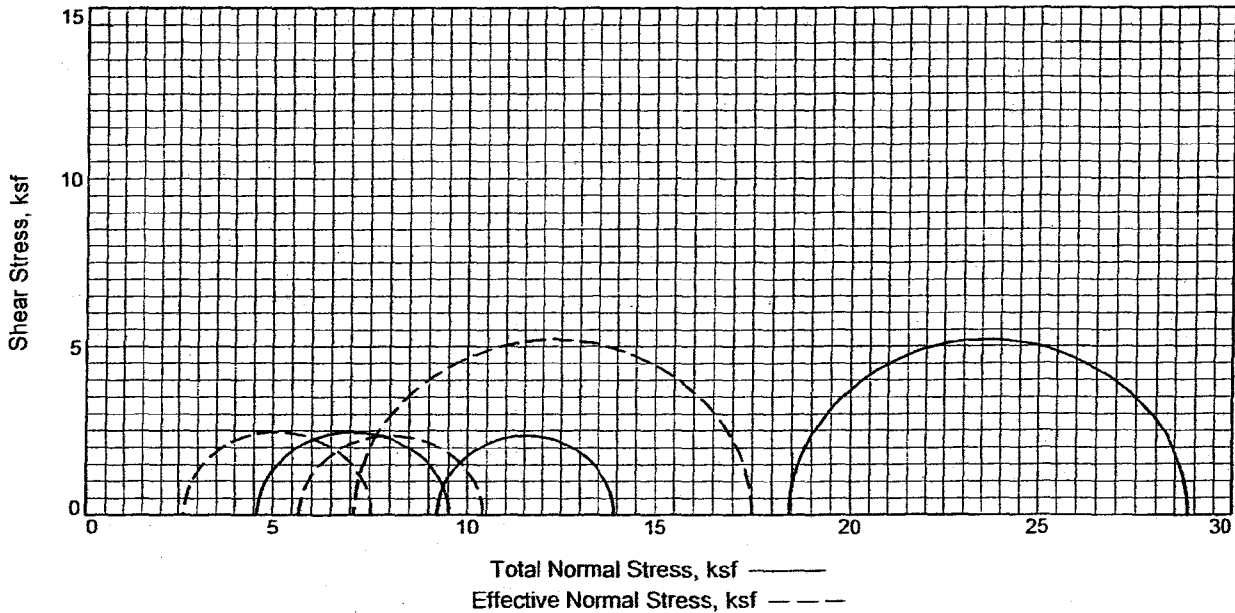

Sample No.	1	2	3	
Initial	Water Content,	24.5	29.9	26.5
	Dry Density, pcf	97.3	90.8	90.0
	Saturation,	92.4	95.8	83.5
	Void Ratio	0.7062	0.8288	0.8444
	Diameter, in.	2.85	2.84	2.89
	Height, in.	5.98	6.09	5.88
At Test	Water Content,	21.5	24.4	24.8
	Dry Density, pcf	105.7	100.6	100.1
	Saturation,	100.0	100.0	100.0
	Void Ratio	0.5717	0.6499	0.6587
	Diameter, in.	2.78	2.75	2.79
	Height, in.	5.82	5.88	5.68
Strain rate, in./min.	0.02	0.02	0.02	
Back Pressure, ksf	2.9	2.9	2.9	
Cell Pressure, ksf	7.5	12.1	21.3	
Fail. Stress, ksf	4.9	4.7	10.4	
Total Pore Pr., ksf	4.9	6.4	14.2	
Ult. Stress, ksf				
Total Pore Pr., ksf				
$\bar{\sigma}_1$ Failure, ksf	7.6	10.4	17.5	
$\bar{\sigma}_3$ Failure, ksf	2.6	5.7	7.1	

**Type of Test:**  
CU with Pore Pressures

**Sample Type:** undisturbed

**Description:** Dark gray lean clay with sand

LL= 36      PL= 21      PI= 15

Specific Gravity= 2.66

Remarks: CL

**Client:** TVA

**Project:** TVA Kingston - Proposed Gypsum Stack

**Location:** NB-21A

**Sample Number:** UD-4, 5 & 6 (CU)      **Depth:** 30'-38'

**Proj. No.:** 3043051021      **Date:**

TRIAXIAL SHEAR TEST REPORT

**MACTEC, INC.**

Figure \_\_\_\_\_

Tested By: Alexander

Checked By: Hamlett

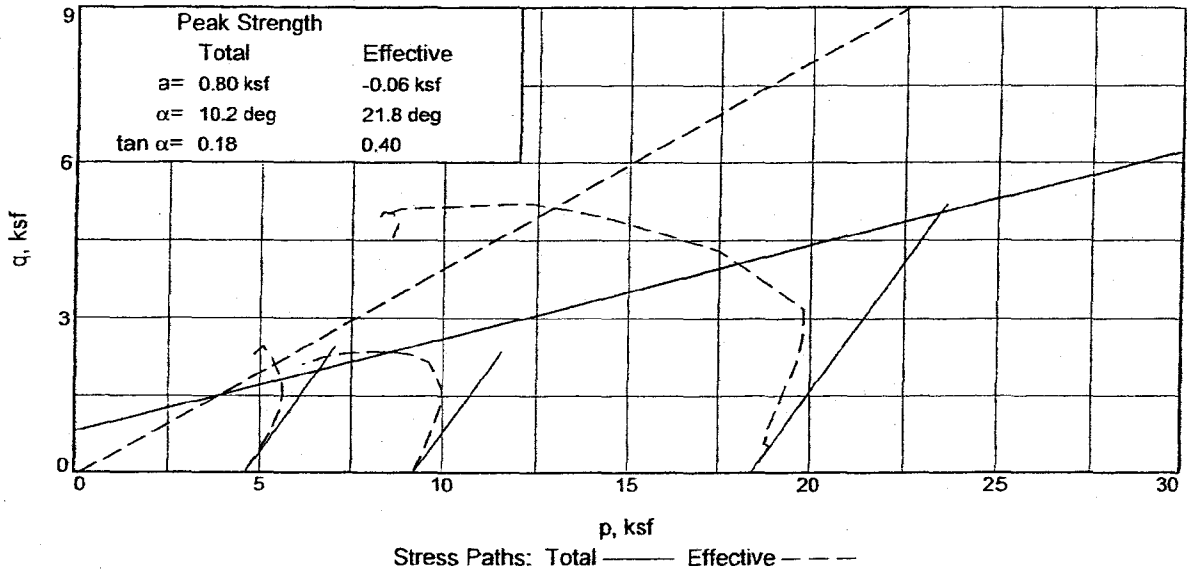
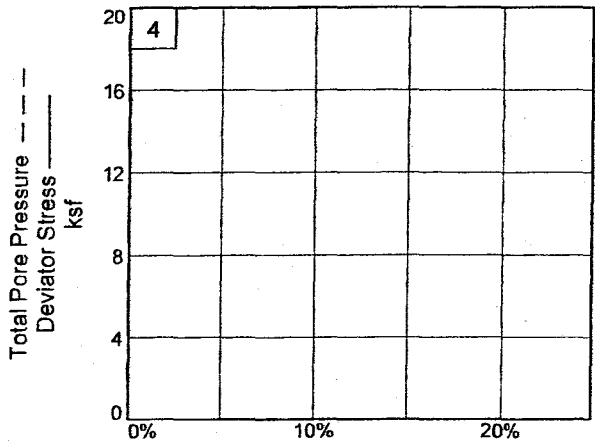
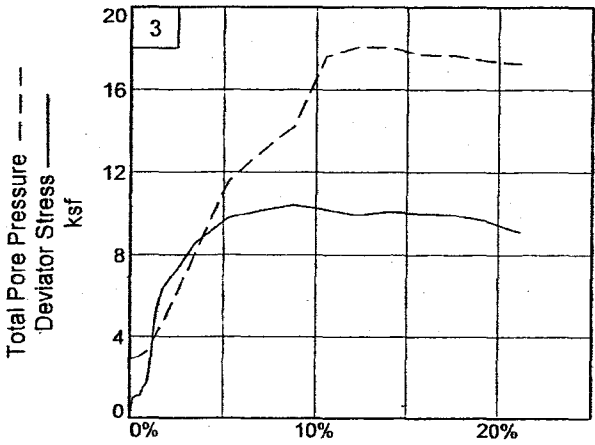
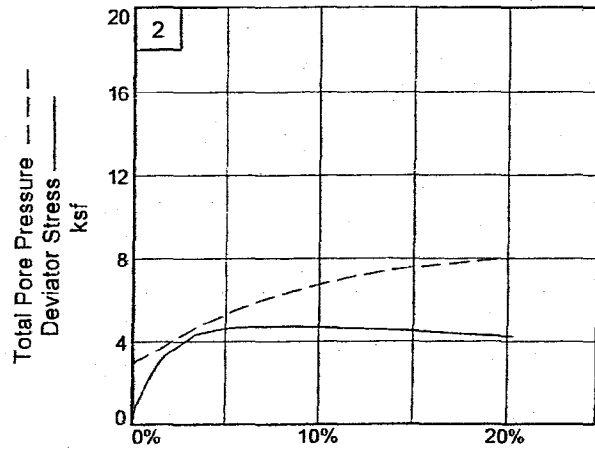
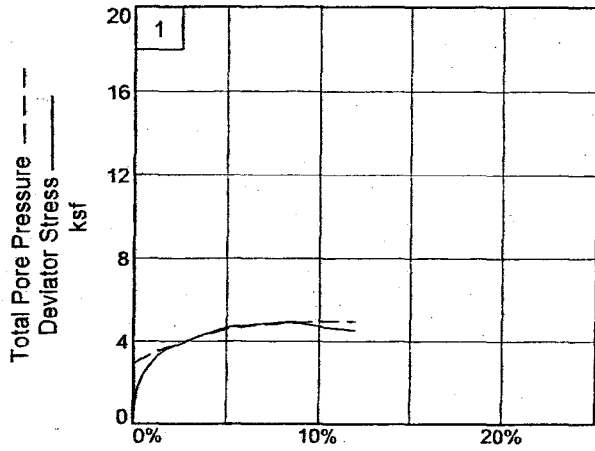

Client: TVA

Project: TVA Kingston - Proposed Gypsum Stack

Location: NB-21A

Depth: 30'-38'

Sample Number: UD-4, 5 & 6 (CU)

Project No.: 3043051021

Figure \_\_\_\_\_

**MACTEC, INC.**

Tested By: Alexander

Checked By: Hamlett



No.	Def. Dial in.	Load Dial	Load lbs.	Strain %	Deviator Stress ksf	Minor Eff. Stress ksf	Major Eff. Stress ksf	1:3 Ratio	Pore Press. psi	P ksf	Q ksf
0	0.0000	0.0	0.0	0.0	0.00	4.61	4.61	1.00	20.00	4.61	0.00
1	0.0100	96.0	69.1	0.2	1.64	4.49	6.13	1.37	20.80	5.31	0.82
2	0.0200	121.0	87.1	0.3	2.07	4.39	6.46	1.47	21.50	5.43	1.03
3	0.0300	142.0	102.2	0.5	2.42	4.33	6.76	1.56	21.90	5.54	1.21
4	0.0400	156.0	112.3	0.7	2.65	4.25	6.90	1.62	22.50	5.58	1.33
5	0.0500	168.0	121.0	0.9	2.85	4.18	7.03	1.68	23.00	5.60	1.43
6	0.0600	180.0	129.6	1.0	3.05	4.10	7.16	1.74	23.50	5.63	1.53
7	0.0700	189.0	136.1	1.2	3.20	4.03	7.23	1.79	24.00	5.63	1.60
8	0.0800	198.0	142.6	1.4	3.35	3.96	7.31	1.84	24.50	5.63	1.67
9	0.0900	204.0	146.9	1.5	3.44	3.90	7.34	1.88	24.90	5.62	1.72
10	0.1000	211.0	151.9	1.7	3.55	3.84	7.40	1.92	25.30	5.62	1.78
11	0.2000	254.0	182.9	3.4	4.20	3.31	7.51	2.27	29.00	5.41	2.10
12	0.3000	287.0	206.6	5.2	4.66	2.92	7.59	2.60	31.70	5.26	2.33
13	0.4000	301.0	216.7	6.9	4.80	2.72	7.52	2.76	33.10	5.12	2.40
14	0.5000	314.0	226.1	8.6	4.92	2.64	7.55	2.87	33.70	5.09	2.46
15	0.6000	303.0	218.2	10.3	4.66	2.55	7.21	2.83	34.30	4.88	2.33
16	0.7000	298.0	214.6	12.0	4.49	2.56	7.06	2.75	34.20	4.81	2.25

Specimen Parameter	Initial	Saturated	Consolidated	Final
Moisture content: Moist soil+tare, gms.	1228.800			600.630
Moisture content: Dry soil+tare, gms.	946.300			478.110
Moisture content: Tare, gms.	0.000			14.160
Moisture, %	29.9	31.2	24.4	26.4
Moist specimen weight, gms.	1196.2			
Diameter, in.	2.84	2.84	2.75	
Area, in. <sup>2</sup>	6.35	6.35	5.92	
Height, in.	6.09	6.09	5.88	
Net decrease in height, in.		0.00	0.20	
Wet Density, pcf	117.9	119.1	125.2	
Dry density, pcf	90.8	90.8	100.6	
Void ratio	0.8288	0.8288	0.6499	
Saturation, %	95.8	100.0	100.0	

Load ring constant = 0.72 lbs. per input unit

Consolidation cell pressure = 84.00 psi (12.10 ksf)

Consolidation back pressure = 20.00 psi (2.88 ksf)

Consolidation effective confining stress = 9.22 ksf

Strain rate, in./min. = 0.02

Fail. Stress = 4.71 ksf at reading no. 14

No.	Def. Dial in.	Load Dial	Load lbs.	Strain %	Deviator Stress ksf	Minor Eff. Stress ksf	Major Eff. Stress ksf	1:3 Ratio	Pore Press. psi	P ksf	Q ksf
0	0.0000	0.0	0.0	0.0	0.00	9.22	9.22	1.00	20.00	9.22	0.00
1	0.0100	51.0	36.7	0.2	0.89	9.04	9.93	1.10	21.20	9.49	0.45
2	0.0200	70.0	50.4	0.3	1.22	8.97	10.19	1.14	21.70	9.58	0.61
3	0.0300	87.0	62.6	0.5	1.51	8.91	10.43	1.17	22.10	9.67	0.76
4	0.0400	105.0	75.6	0.7	1.82	8.84	10.67	1.21	22.60	9.75	0.91
5	0.0500	122.0	87.8	0.8	2.12	8.76	10.87	1.24	23.20	9.81	1.06
6	0.0600	139.0	100.1	1.0	2.41	8.68	11.09	1.28	23.70	9.89	1.20
7	0.0700	154.0	110.9	1.2	2.66	8.61	11.27	1.31	24.20	9.94	1.33
8	0.0800	167.0	120.2	1.4	2.88	8.52	11.41	1.34	24.80	9.97	1.44
9	0.0900	179.0	128.9	1.5	3.08	8.44	11.52	1.37	25.40	9.98	1.54
10	0.1000	190.0	136.8	1.7	3.27	8.34	11.61	1.39	26.10	9.97	1.63
11	0.2000	255.0	183.6	3.4	4.31	7.46	11.77	1.58	32.20	9.61	2.16
12	0.3000	278.0	200.2	5.1	4.62	6.75	11.37	1.68	37.10	9.06	2.31
13	0.4000	288.0	207.4	6.8	4.70	6.16	10.86	1.76	41.20	8.51	2.35
14	0.5000	294.0	211.7	8.5	4.71	5.69	10.40	1.83	44.50	8.04	2.35
15	0.6000	297.0	213.8	10.2	4.67	5.30	9.97	1.88	47.20	7.63	2.33
16	0.7000	299.0	215.3	11.9	4.61	4.97	9.58	1.93	49.50	7.27	2.30
17	0.8000	301.0	216.7	13.6	4.55	4.71	9.26	1.97	51.30	6.98	2.28
18	0.9000	302.0	217.4	15.3	4.48	4.49	8.97	2.00	52.80	6.73	2.24
19	1.0000	301.0	216.7	17.0	4.37	4.33	8.71	2.01	53.90	6.52	2.19
20	1.1000	302.0	217.4	18.7	4.30	4.19	8.49	2.03	54.90	6.34	2.15
21	1.2000	303.0	218.2	20.4	4.22	4.08	8.30	2.04	55.70	6.19	2.11



Specimen Parameter	Initial	Saturated	Consolidated	Final
Moisture content: Moist soil+tare, gms.	1196.100			534.570
Moisture content: Dry soil+tare, gms.	945.400			438.140
Moisture content: Tare, gms.	0.000			8.080
Moisture, %	26.5	31.7	24.8	22.4
Moist specimen weight, gms.	1157.1			
Diameter, in.	2.89	2.89	2.79	
Area, in. <sup>2</sup>	6.58	6.58	6.13	
Height, in.	5.88	5.88	5.68	
Net decrease in height, in.		0.00	0.20	
Wet Density, pcf	113.9	118.6	124.9	
Dry density, pcf	90.0	90.0	100.1	
Void ratio	0.8444	0.8444	0.6587	
Saturation, %	83.5	100.0	100.0	

Load ring constant = 0.72 lbs. per input unit

Consolidation cell pressure = 148.00 psi (21.31 ksf)

Consolidation back pressure = 20.00 psi (2.88 ksf)

Consolidation effective confining stress = 18.43 ksf

Strain rate, in./min. = 0.02

Fail. Stress = 10.40 ksf at reading no. 14

No.	Def. Dial in.	Load Dial	Load lbs.	Strain %	Deviator Stress ksf	Minor Eff. Stress ksf	Major Eff. Stress ksf	1:3 Ratio	Pore Press. psi	P ksf	Q ksf
0	0.0000	0.0	0.0	0.0	0.00	18.43	18.43	1.00	20.00	18.43	0.00
1	0.0100	59.0	42.5	0.2	1.00	18.40	19.40	1.05	20.20	18.90	0.50
2	0.0200	65.0	46.8	0.4	1.10	18.32	19.41	1.06	20.80	18.86	0.55
3	0.0300	65.0	46.8	0.5	1.09	18.23	19.32	1.06	21.40	18.78	0.55
4	0.0400	88.0	63.4	0.7	1.48	18.13	19.61	1.08	22.10	18.87	0.74
5	0.0500	104.0	74.9	0.9	1.74	18.01	19.76	1.10	22.90	18.89	0.87
6	0.0600	151.0	108.7	1.1	2.53	17.86	20.38	1.14	24.00	19.12	1.26
7	0.0700	252.0	181.4	1.2	4.21	17.52	21.74	1.24	26.30	19.63	2.11
8	0.0800	313.0	225.4	1.4	5.22	17.19	22.42	1.30	28.60	19.80	2.61
9	0.0900	351.0	252.7	1.6	5.85	16.91	22.75	1.35	30.60	19.83	2.92
10	0.1000	383.0	275.8	1.8	6.37	16.63	23.00	1.38	32.50	19.82	3.18
11	0.2000	528.0	380.2	3.5	8.62	13.18	21.80	1.65	56.50	17.49	4.31
12	0.3000	610.0	439.2	5.3	9.78	9.73	19.51	2.00	80.40	14.62	4.89
13	0.4000	645.0	464.4	7.0	10.15	8.31	18.46	2.22	90.30	13.38	5.07
14	0.5000	674.0	485.3	8.8	10.40	7.10	17.50	2.47	98.70	12.30	5.20
15	0.6000	674.0	485.3	10.6	10.20	3.72	13.92	3.75	122.20	8.82	5.10
16	0.7000	668.0	481.0	12.3	9.91	3.28	13.20	4.02	125.20	8.24	4.96
17	0.8000	694.0	499.7	14.1	10.09	3.28	13.37	4.07	125.20	8.33	5.05
18	0.9000	702.0	505.4	15.8	10.00	3.63	13.63	3.76	122.80	8.63	5.00
19	1.0000	712.0	512.6	17.6	9.93	3.66	13.59	3.71	122.60	8.62	4.96
20	1.1000	706.0	508.3	19.4	9.63	3.93	13.57	3.45	120.70	8.75	4.82
21	1.2000	682.0	491.0	21.1	9.10	4.05	13.15	3.25	119.90	8.60	4.55

## CONSOLIDATED UNDRAINED TRIAXIAL TEST

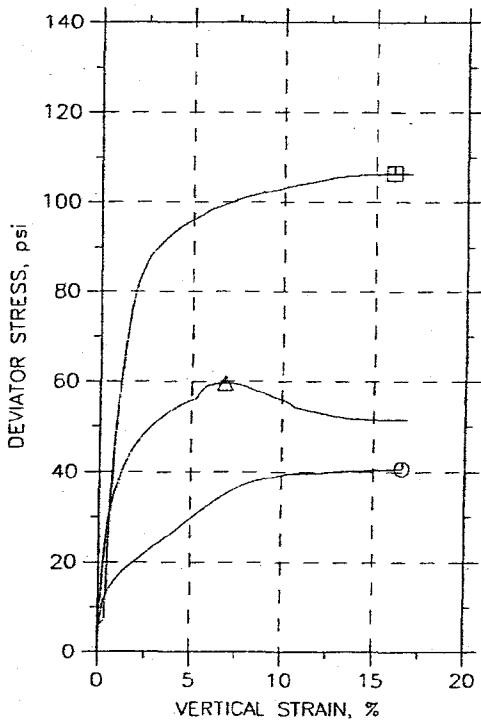
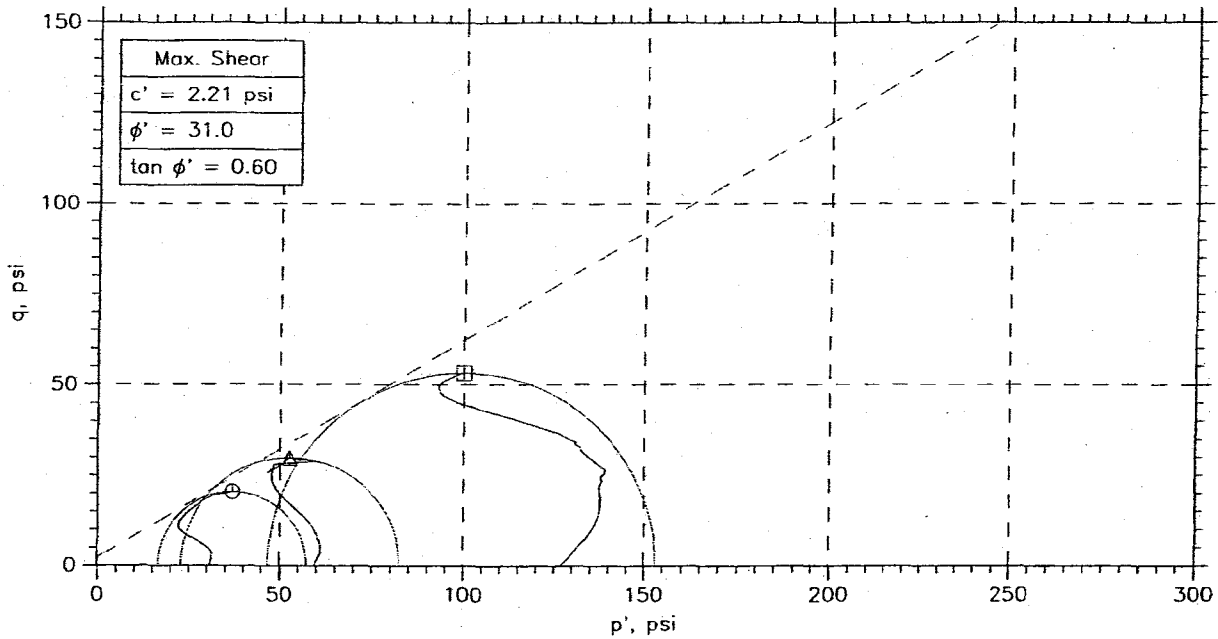

Symbol	○	△	□	
Sample No.	UD-4	UD-4	UD-4	
Test No.	13775.1	13775.2	13775.3	
Depth	31-33 Ft.	31-33 ft	31-33 ft	
Initial	Diameter, in	2.85	2.828	2.87
	Height, in	5.57	5.57	5.57
	Water Content, %	27.4	26.7	26.4
Before Shear	Dry Density, pcf	95.63	96.16	97.38
	Saturation, %	97.6	96.1	98.0
	Void Ratio	0.756	0.746	0.724
	Water Content, %	24.7	24.3	21.0
Before Shear	Dry Density, pcf	100.9	101.4	107.4
	Saturation*, %	100.0	99.7	100.0
	Void Ratio	0.665	0.656	0.564
Back Press., psi	59.99	72.03	20	
Ver. Eff. Cons. Stress, psi	32	63.97	128	
Shear Strength, psi	20.33	29.8	53.19	
Strain at Failure, %	16.5	6.83	16	
Strain Rate, %/min	0.022	0.022	0.022	
B-Value	0.95	0.95	0.95	
Measured Specific Gravity	2.69	2.69	2.69	
Liquid Limit	34	34	34	
Plastic Limit	22	22	22	

<b>GeoTesting</b> <b>express</b> <small>the groundwork for success</small>	Project: TVA Kingston Gypsum Stack				
	Location: NB-21B				
	Project No.: GTX G0959				
	Boring No.: NB-21B				
	Sample Type: Shelby Tube				
Description:					
Remarks:					

Phase calculations based on start and end of test.

\* Saturation is set to 100% for phase calculations.

# CONSOLIDATED UNDRAINED TRIAXIAL TEST

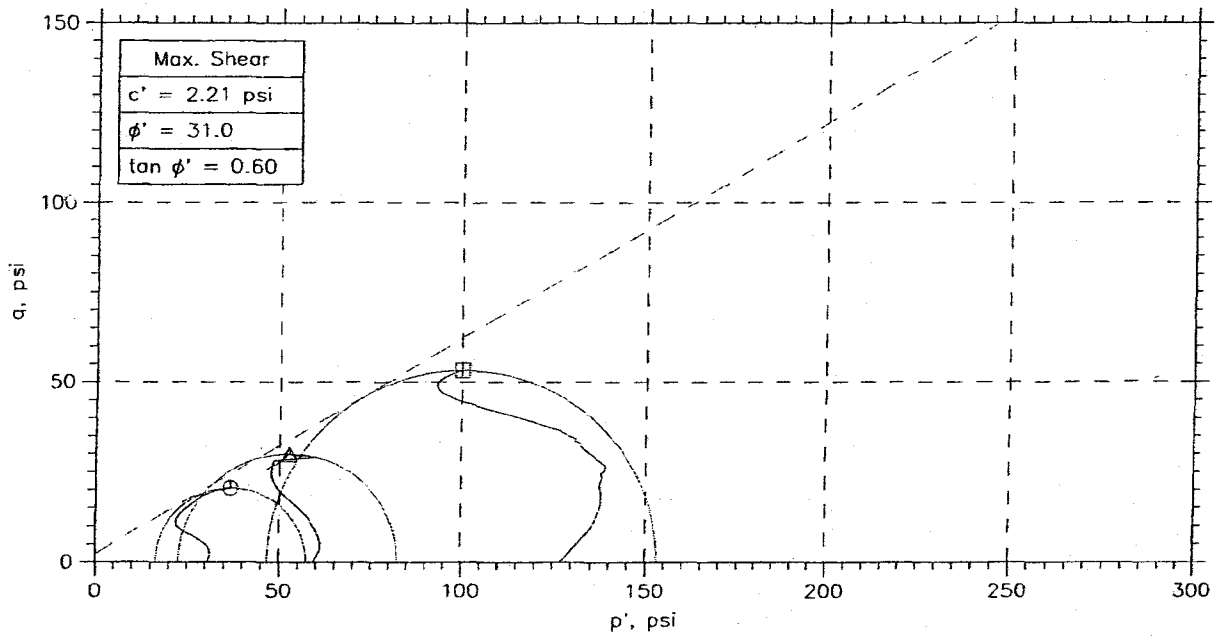
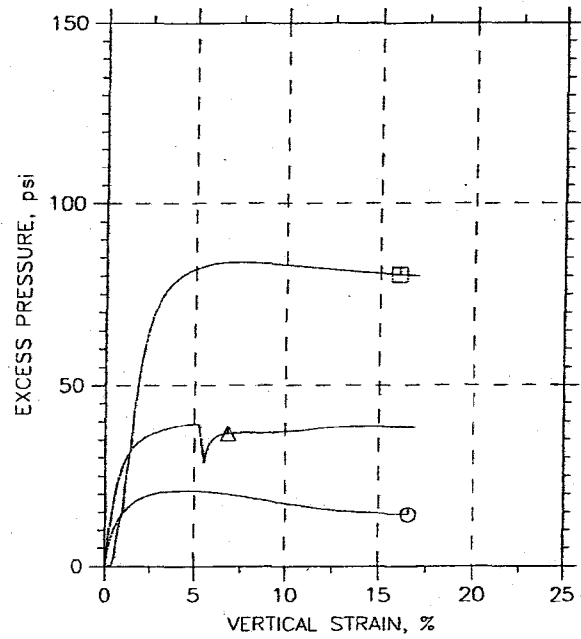
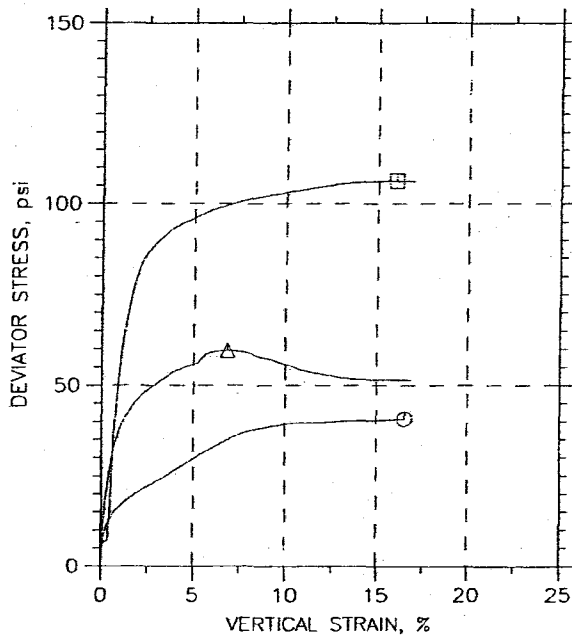

Symbol	Sample No.	Test No.	Depth	Tested By	Test Date	Checked By	Check Date	Test File
○	UD-4	13775.1	31-33 Ft.	JW	12/12/05	HJ		13775.1_2054.dat
△	UD-5	13775.2	31-33 ft	JW	12/12/05	HJ		13775.2_1057.dat
□	UD-4	13775.3	31-33 ft	JW	12/12/05	HJ		13775.3o_1062.dat

<b>GeoTesting</b> <b>express</b> <small>the groundwork for success</small>	Project: TVA Kingston Gypsum Station, Location: NB-21B		Project No.: GTX G0959
	Boring No.: NB-21B		Sample Type: Shelby Tube
	Description:		
	Remarks:		

# CONSOLIDATED UNDRAINED TRIAXIAL TEST

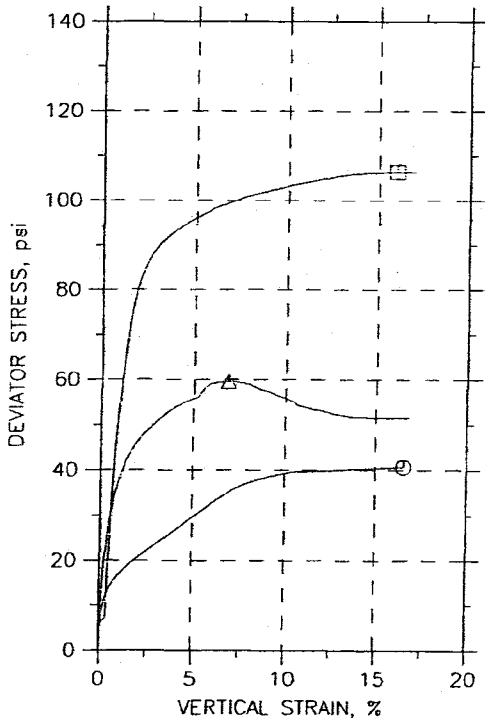
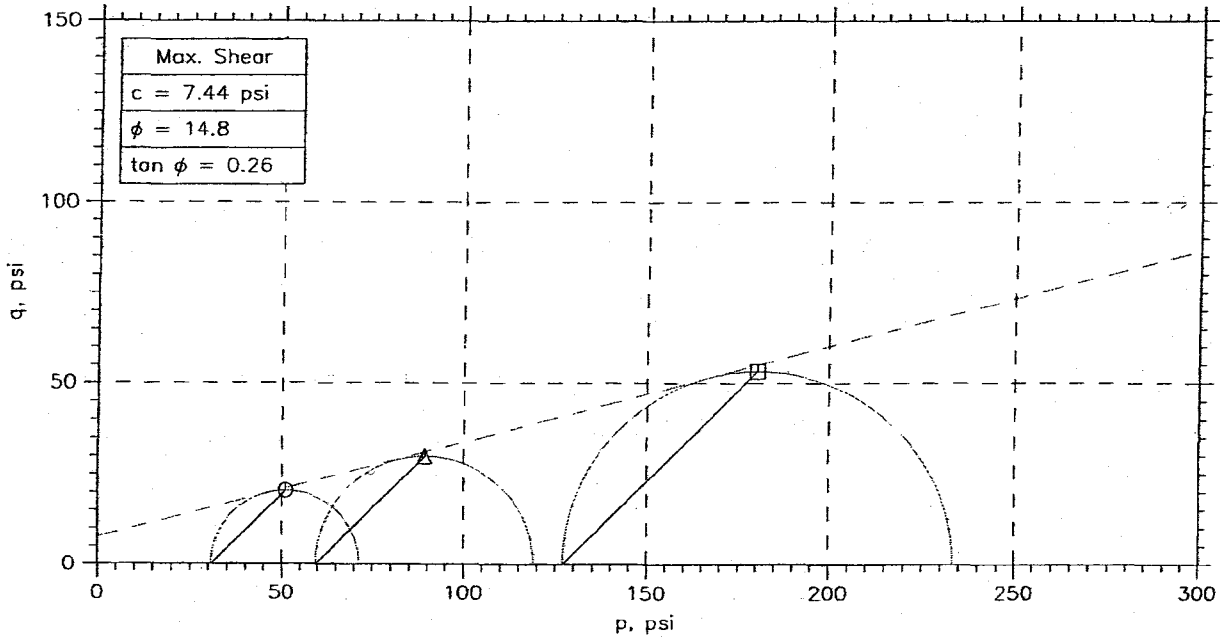

Symbol	○	△	□	
Sample No.	UD-4	UD-4	UD-4	
Test No.	13775.1	13775.2	13775.3	
Depth	31-33 Ft.	31-33 ft	31-33 ft	
Initial	Diameter, in	2.85	2.828	2.87
	Height, in	5.57	5.57	5.57
	Water Content, %	27.4	26.7	26.4
	Dry Density, pcf	95.63	96.16	97.38
	Saturation, %	97.6	96.1	98.0
	Void Ratio	0.756	0.746	0.724
Before Shear	Water Content, %	24.7	24.3	21.0
	Dry Density, pcf	100.9	101.4	107.4
	Saturation*, %	100.0	99.7	100.0
	Void Ratio	0.665	0.656	0.564
Back Press., psi	59.99	72.03	20	
Ver. Eff. Cons. Stress, psi	32	63.97	128	
Shear Strength, psi	20.33	29.8	53.19	
Strain at Failure, %	16.5	6.83	16	
Strain Rate, %/min	0.022	0.022	0.022	
B-Value	0.95	0.95	0.95	
Measured Specific Gravity	2.69	2.69	2.69	
Liquid Limit	34	34	34	
Plastic Limit	22	22	22	

**GeoTesting**  
**express**  
 the groundwork for success

Project: TVA Kingston Gypsum Stack				
Location: NB-21B				
Project No.: GTX G0959				
Boring No.: NB-21B				
Sample Type: Shelby Tube				
Description:				
Remarks:				

Phase calculations based on start and end of test.

\* Saturation is set to 100% for phase calculations.

## CONSOLIDATED UNDRAINED TRIAXIAL TEST

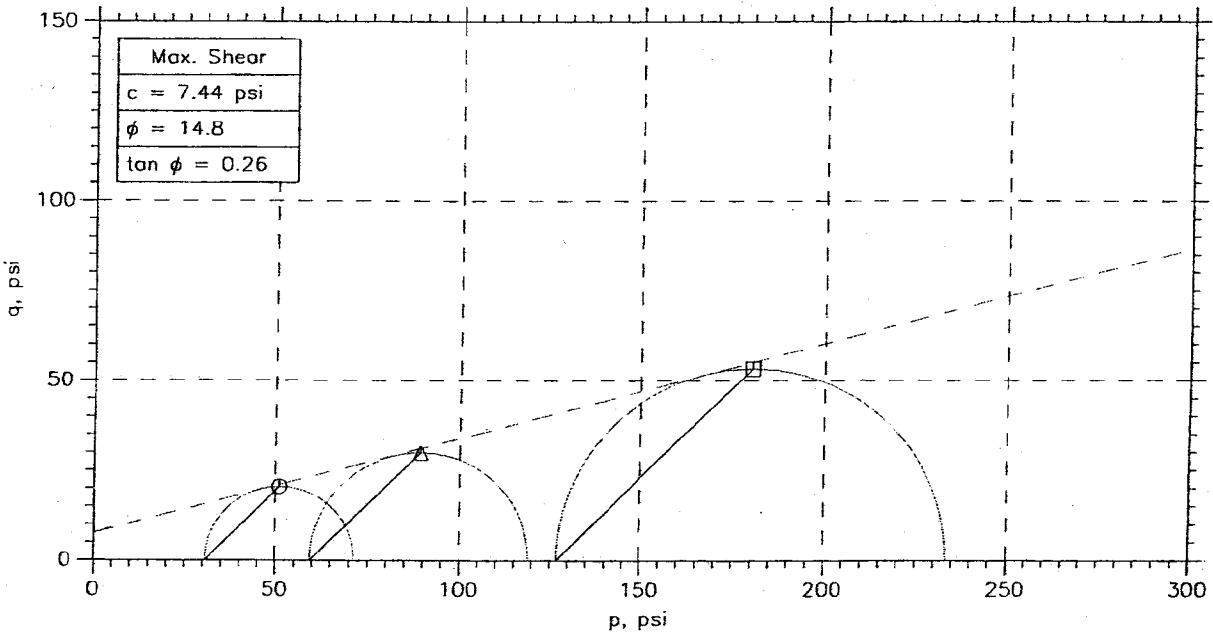
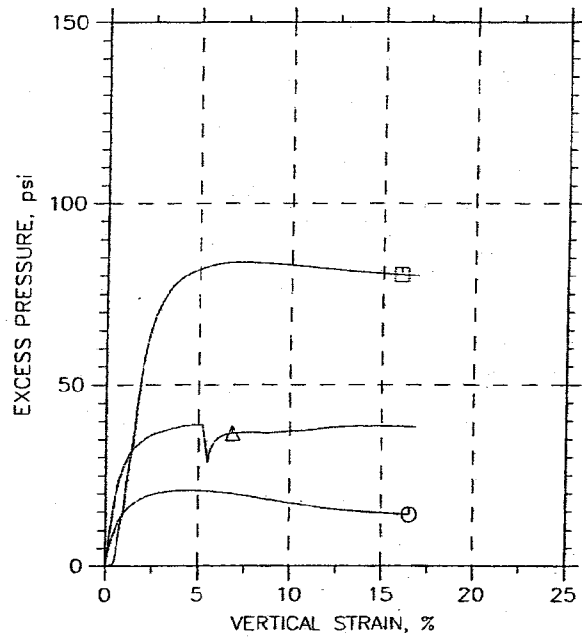
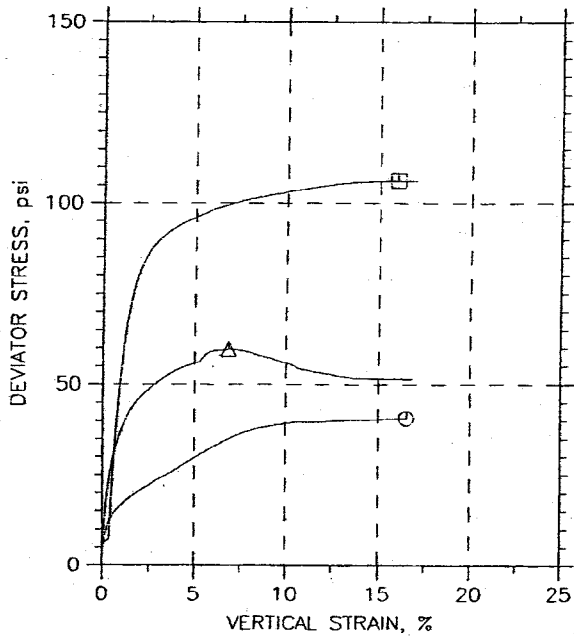

	Sample No.	Test No.	Depth	Tested By	Test Date	Checked By	Check Date	Test File
⊙	UD-4	13775.1	31-33 Ft.	JW	12/12/05	HJ		13775.1_2054.dot
△	UD-5	13775.2	31-33 ft	JW	12/12/05	HJ		13775.2_1057.dot
□	UD-4	13775.3	31-33 ft	JW	12/12/05	HJ		13775.3a_1062.dot

<b>GeoTesting</b> <b>express</b> <small>the groundwork for success</small>	Project: TVA Kingston Gypsum Station		Location: NB-21B	Project No.: GTX G0959
	Boring No.: NB-21 B		Sample Type: Shelby Tube	
	Description:			
	Remarks:			

## CONSOLIDATED UNDRAINED TRIAXIAL TEST

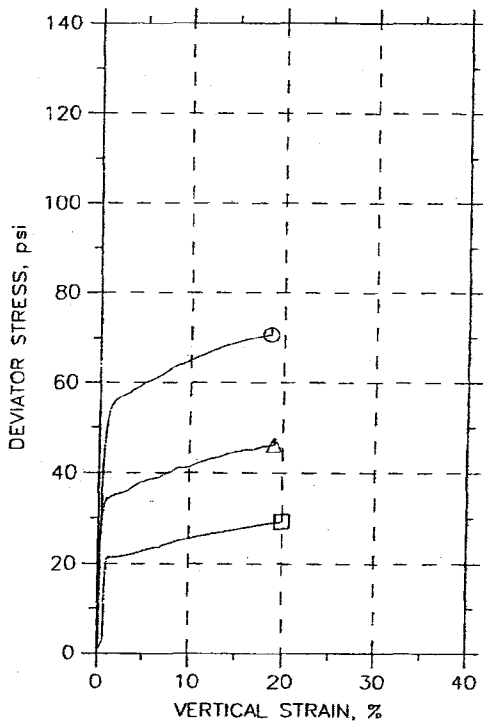
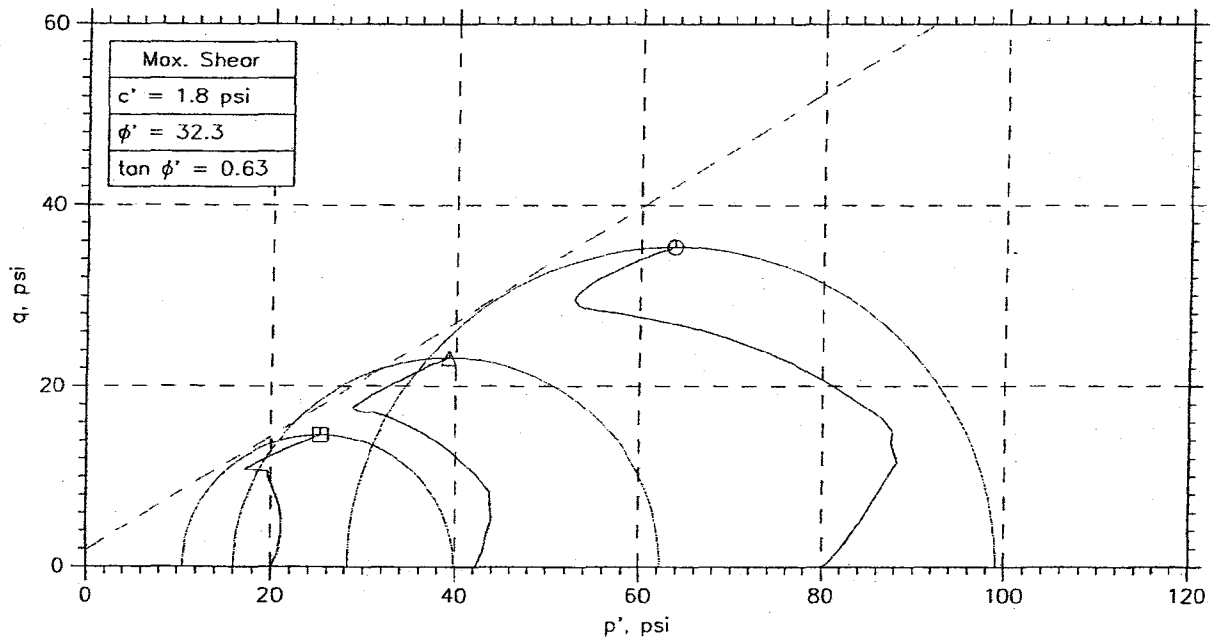

Symbol	○	△	□	
Sample No.	Bag	Bag	Bag	
Test No.	13923.3	13923.2	13923.1	
Depth	2-10 ft	2-10 ft	2-10 ft	
Initial	Diameter, in	2.87	2.87	2.87
	Height, in	6	6	6
	Water Content, %	19.7	19.6	19.7
	Dry Density, pcf	101.9	101.9	102.
	Saturation, %	84.5	84.4	85.0
Before Shear	Void Ratio	0.612	0.612	0.609
	Water Content, %	20.1	21.8	22.9
	Dry Density, pcf	107.5	104.3	102.5
	Saturation*, %	100.0	100.0	100.0
	Void Ratio	0.527	0.574	0.601
Back Press., psi	59.99	<b>89.99</b>	89.99	
Ver. Eff. Cons. Stress, psi	80.01	<b>40.32</b>	20	
Shear Strength, psi	35.34	23.1	14.61	
Strain at Failure, %	18.5	19	19.9	
Strain Rate, %/min	0.022	0.022	0.022	
B-Value	0.95	0.95	0.95	
Measured Specific Gravity	2.63	2.63	2.63	
Liquid Limit	40	40	40	
Plastic Limit	22	22	22	

<b>GeoTesting</b> express <small>the groundwork for success</small>	Project: TVA Kingston Gypsum Stack				
	Location: NB-22				
	Project No.: GTX-G0959				
	Boring No.: NB-22				
	Sample Type: Remolded				
	Description: Reddish Orange Lean Clay with Sand				
Remarks: Remolded to 95% of Standard Proctor max. dry density and +2% over opt.					

Phase calculations based on start and end of test.

\* Saturation is set to 100% for phase calculations.

## CONSOLIDATED UNDRAINED TRIAXIAL TEST

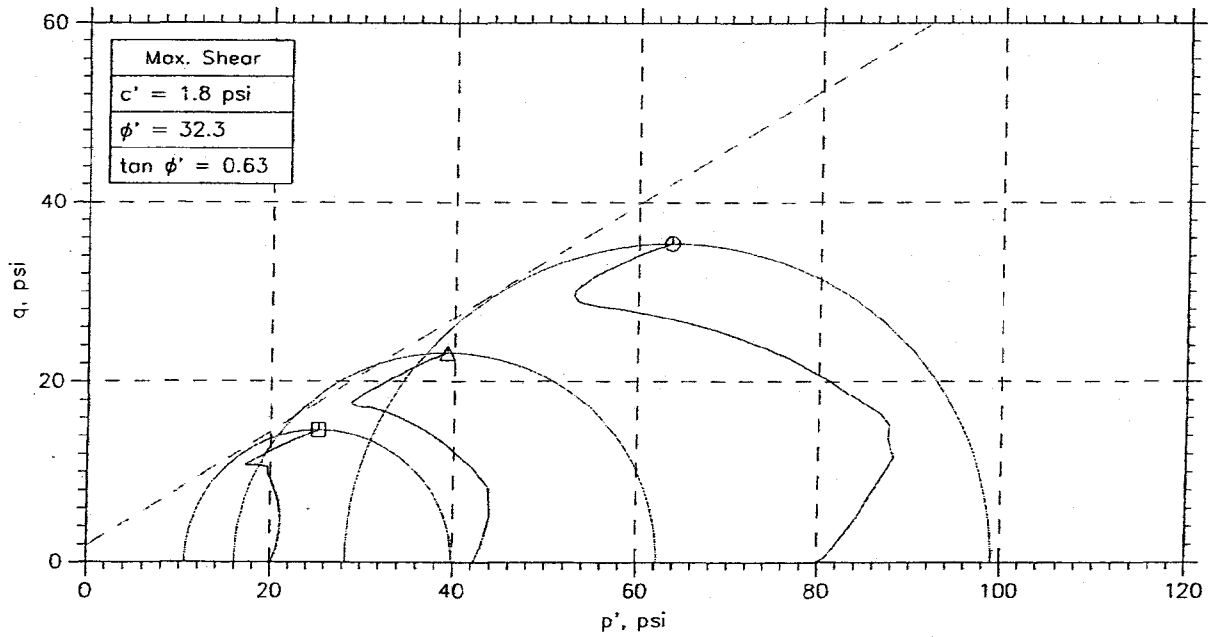
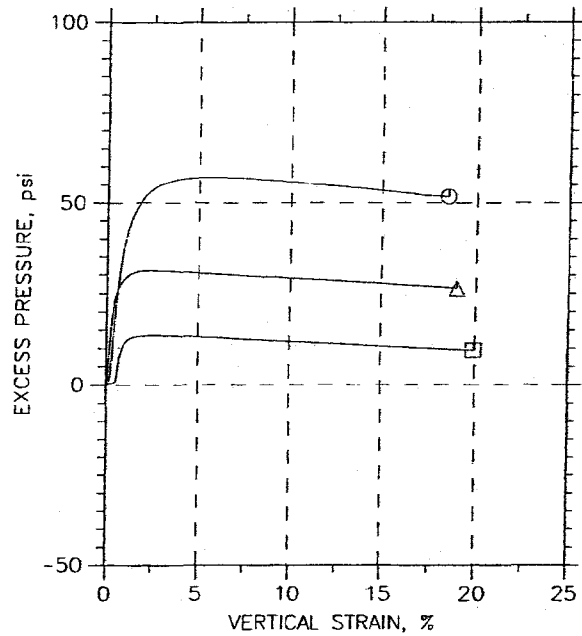
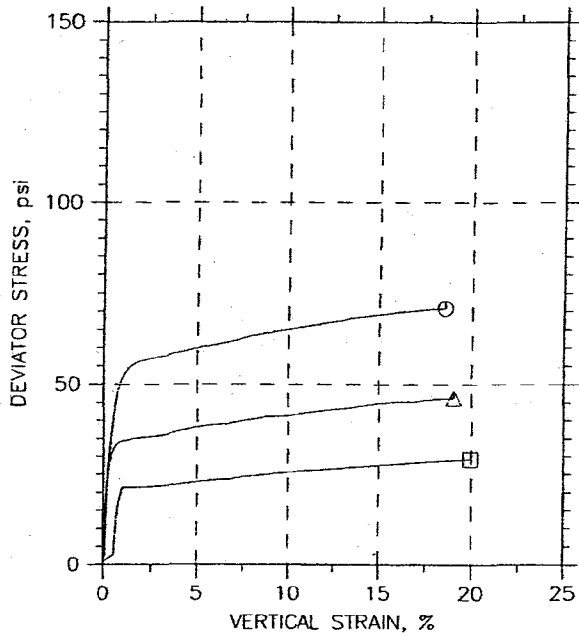

	Sample No.	Test No.	Depth	Tested By	Test Date	Checked By	Check Date	Test File
⊙	Bag	13923.3	2-10 ft	JW	1/13/06	HJ		13923.3a_1062.dat
△	Bag	13923.2	2-10 ft	JW	1/13/05	HJ		13923.2a_1057.dat
□	Bag	13923.1	2-10 ft	HJ	1/13/06	JW		13923.1_2054.dat

<b>GeoTesting</b> <b>xpress</b> <small>the groundwork for success</small>	Project: TVA Kingston Gypsum Stack location: NB-22		Project No.: GTX-G0959
	Boring No.: NB-22		Sample Type: Remolded
	Description: Reddish Orange Lean Clay with Sand		
	Remarks: Remolded to 95% of Standard Proctor max. dry density and +2% over opt.		

## CONSOLIDATED UNDRAINED TRIAXIAL TEST

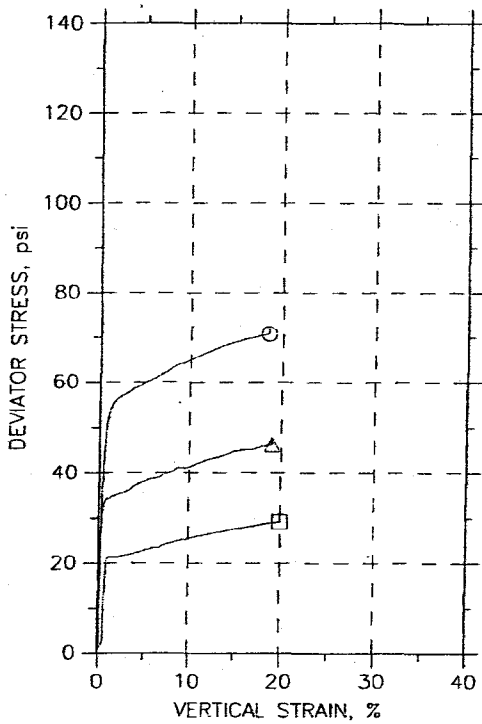
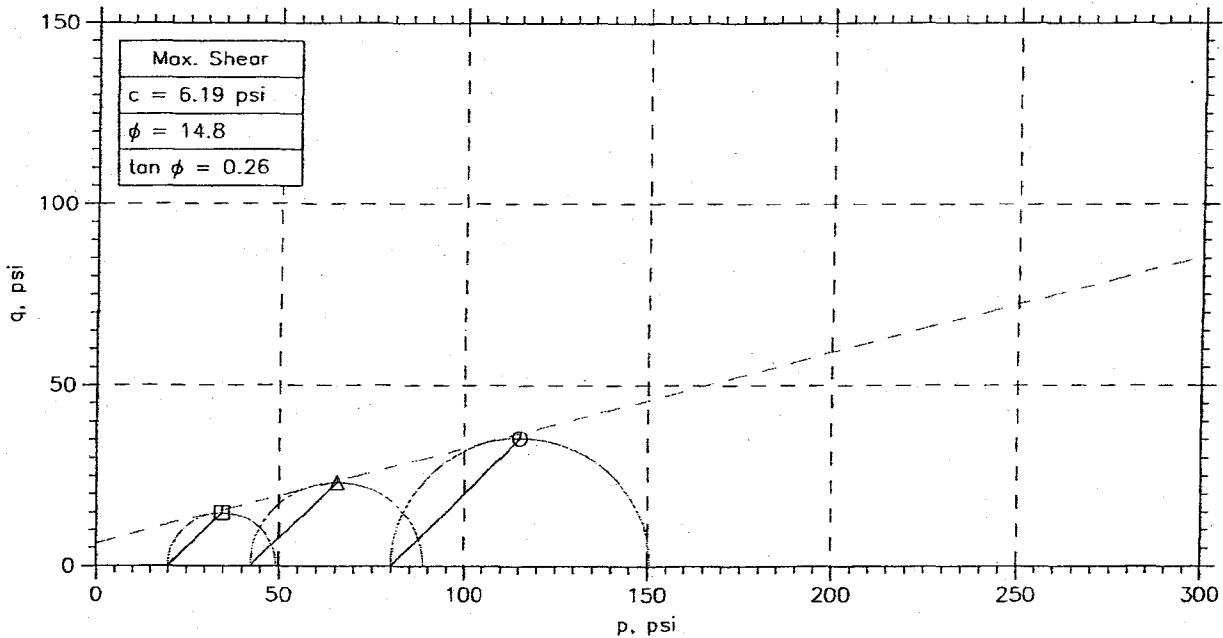

Symbol	⊙	△	□	
Sample No.	Bag	Bag	Bag	
Test No.	13923.3	13923.2	13923.1	
Depth	2-10 ft	2-10 ft	2-10 ft	
Initial	Diameter, in	2.87	2.87	2.87
	Height, in	6	6	6
	Water Content, %	19.7	19.6	19.7
	Dry Density, pcf	101.9	101.9	102.
	Saturation, %	84.5	84.4	85.0
Before Shear	Void Ratio	0.612	0.612	0.609
	Water Content, %	20.1	21.8	22.9
	Dry Density, pcf	107.5	104.3	102.5
	Saturation*, %	100.0	100.0	100.0
Back Press., psi		59.99	<b>89.99</b>	89.99
	Ver. Eff. Cons. Stress, psi	80.01	<b>40.32</b>	20
Shear Strength, psi	35.34	23.1	14.61	
Strain at Failure, %	18.5	19	19.9	
Strain Rate, %/min	0.022	0.022	0.022	
B-Value	0.95	0.95	0.95	
Measured Specific Gravity	2.63	2.63	2.63	
Liquid Limit	40	40	40	
Plastic Limit	22	22	22	

**GeoTesting**  
xpress

the groundwork for success

Project: TVA Kingston Gypsym Stack				
Location: NB-22				
Project No.: GTX-G0959				
Boring No.: NB-22				
Sample Type: Remolded				
Description: Reddish Orange Lean Clay with Sand				
Remarks: Remolded to 95% of Standard Proctor max. dry density and +2% over opt.				

Phase calculations based on start and end of test.

\* Saturation is set to 100% for phase calculations.



## CONSOLIDATED UNDRAINED TRIAXIAL TEST

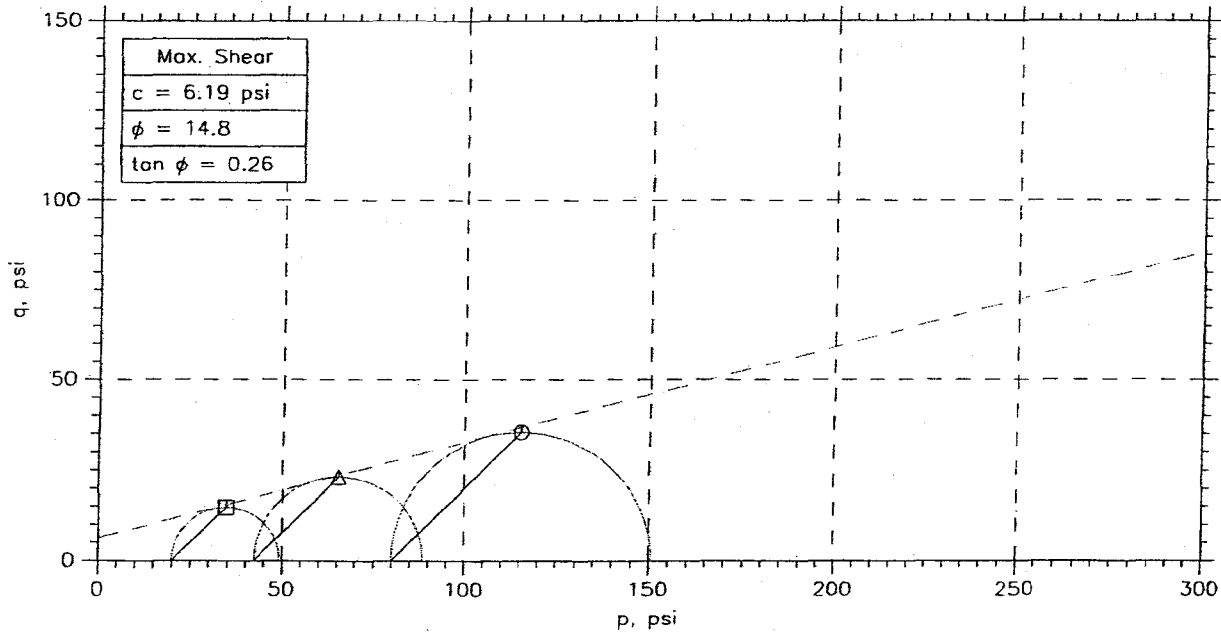
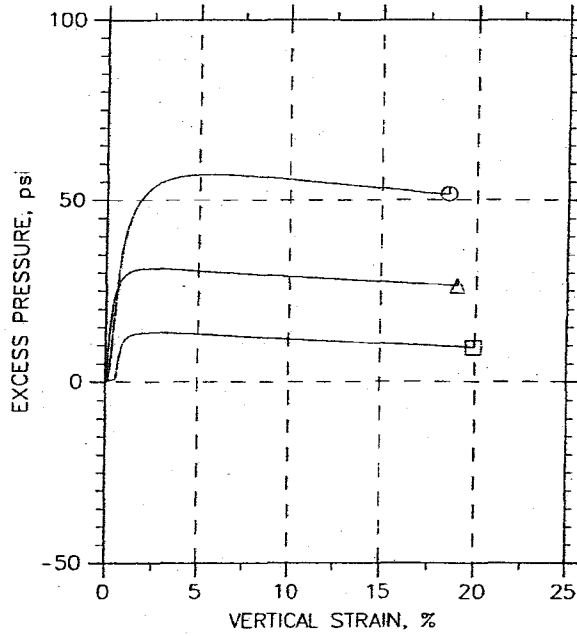
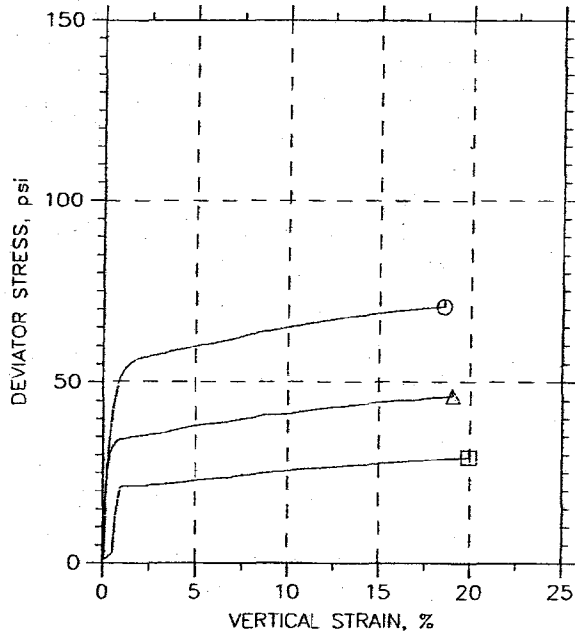

Sample No.	Test No.	Depth	Tested By	Test Date	Checked By	Check Date	Test File
⊙	13923.3	2-10 ft	JW	1/13/06	HJ		13923.3o_1062.dat
△	13923.2	2-10 ft	JW	1/13/05	HJ		13923.2o_1057.dat
□	13923.1	2-10 ft	HJ	1/13/06	JW		13923.1_2054.dat

<b>GeoTesting</b> <b>express</b> <small>the groundwork for success</small>	Project: TVA Kingston Gypsum Station Location: NB-22		Project No.: GTX-G0959
	Boring No.: NB-22		Sample Type: Remolded
	Description: Reddish Orange Lean Clay with Sand		
	Remarks: Remolded to 95% of Standard Proctor max. dry density and +2% over opt.		

## CONSOLIDATED UNDRAINED TRIAXIAL TEST

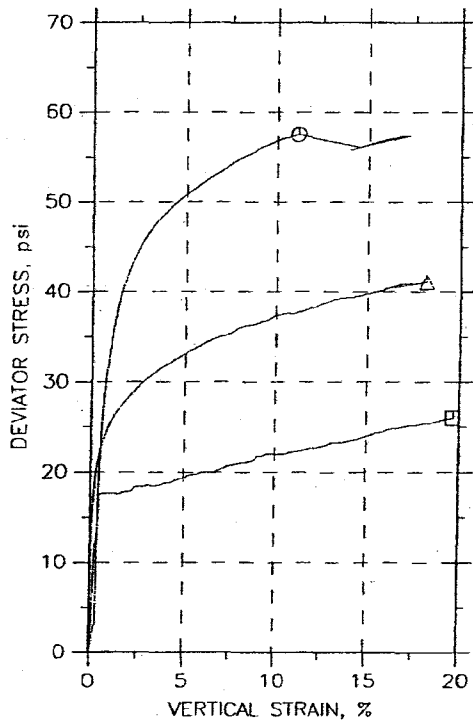
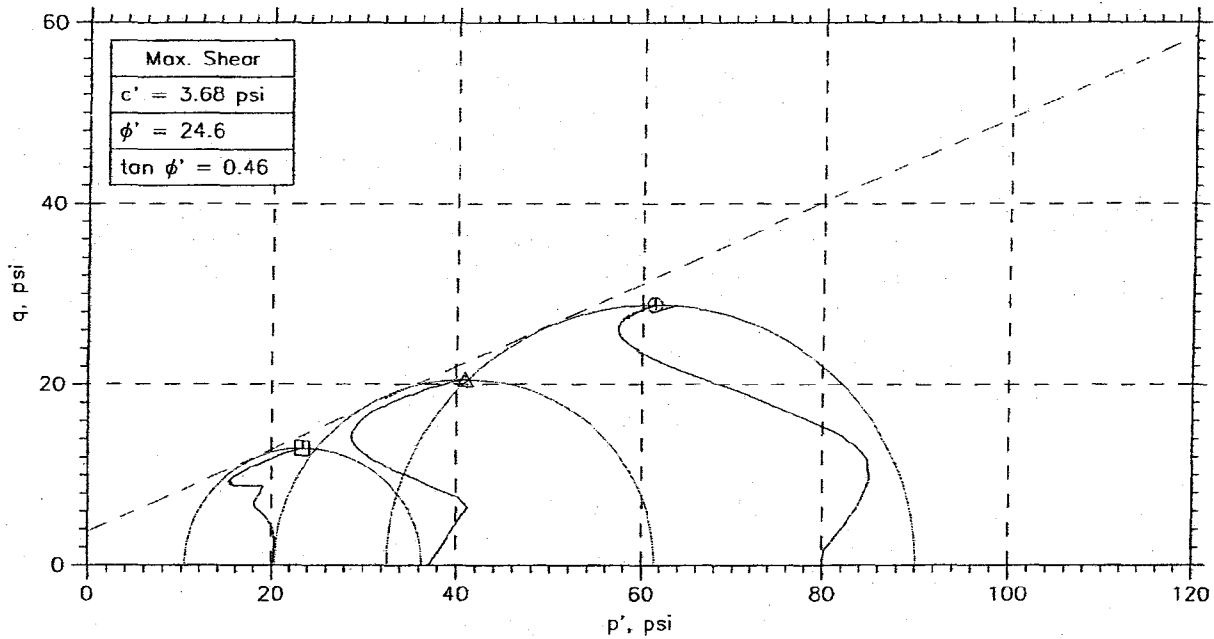

Symbol	○	△	□	
Sample No.	Bag	Bag	Bag	
Test No.	13924.3	13924.2	13924.1	
Depth	2-10 ft	2-10 ft	2-10 ft	
Initial	Diameter, in	2.87	2.87	2.87
	Height, in	6	6	6
	Water Content, %	27.5	27.6	27.3
	Dry Density, pcf	90.23	90.2	90.68
	Saturation, %	84.1	84.3	84.3
Before Shear	Void Ratio	0.896	0.896	0.886
	Water Content, %	29.4	30.4	30.8
	Dry Density, pcf	94.76	93.33	92.76
	Saturation*, %	100.1	100.0	100.0
Void Ratio	0.805	0.833	0.844	
Back Press., psi	60	90	80.01	
Ver. Eff. Cons. Stress, psi	80	40	19.99	
Shear Strength, psi	28.76	20.54	12.97	
Strain at Failure, %	11.2	18.2	19.7	
Strain Rate, %/min	0.022	0.022	0.022	
B-Value	0.95	0.95	0.95	
Measured Specific Gravity	2.74	2.74	2.74	
Liquid Limit	72	72	72	
Plastic Limit	25	25	25	

<b>GeoTesting</b> express <small>the groundwork for success</small>	Project: TVA Kingston Gypsum Stack				
	Location: NB-25				
	Project No.: GTX-G0959				
	Boring No.: NB-25				
	Sample Type: Remolded				
Description: Orange Brown Fat Clay					
Remarks: Remolded to 95% of Standard Proctor max. dry density and +2% opt. moisture content.					

Phase calculations based on start and end of test.  
 \* Saturation is set to 100% for phase calculations.

## CONSOLIDATED UNDRAINED TRIAXIAL TEST

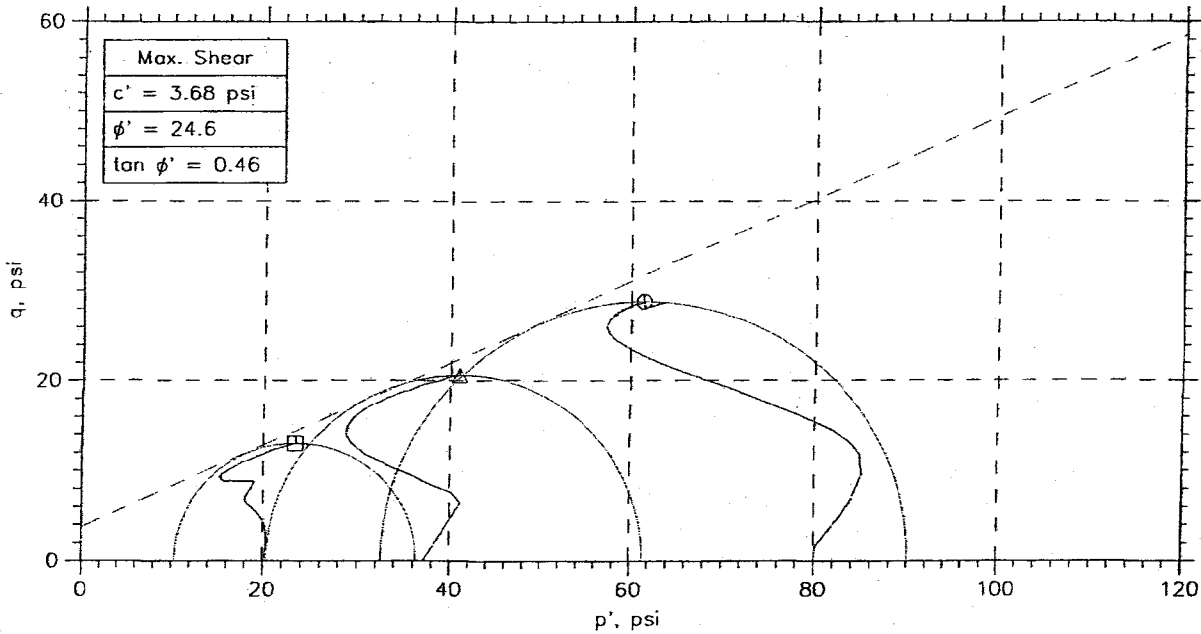
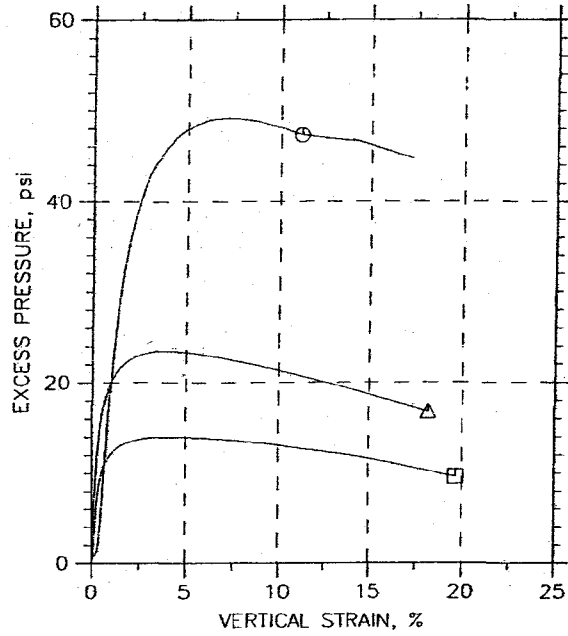
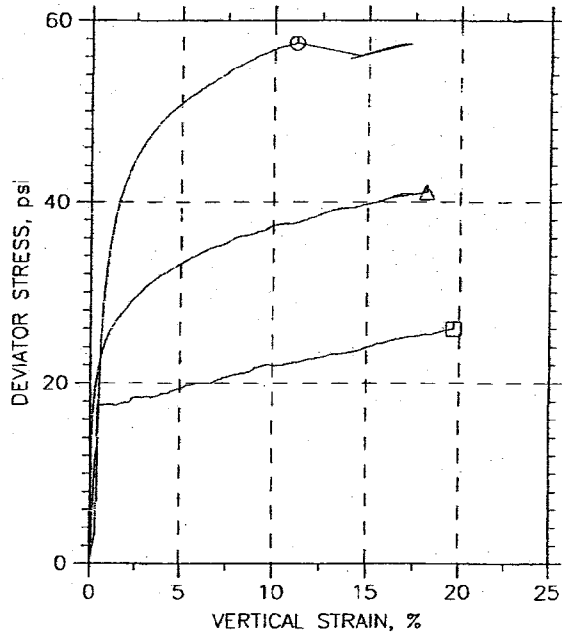

Sample No.	Test No.	Depth	Tested By	Test Date	Checked By	Check Date	Test File
⊙	Bag 13924.3	2-10 ft	JW	1/19/06	HJ		13924.3b_1062.dot
△	Bag 13924.2	2-10 ft	JW	1/19/05	HJ		13924.2_1057.dot
□	Bag 13924.1	2-10 ft	HJ	1/19/06	JW		13924.1a_2054.dot

<b>GeoTesting</b> <b>express</b> <small>the groundwork for success</small>	Project: TVA Kingston Gypsum Storage		Location: NB-25		Project No.: GTX-G0959	
	Boring No.: NB-25		Sample Type: Remolded			
	Description: Orange Brown Fat Clay					
	Remarks: Remolded to 95% of Standard Proctor max. dry density and +2% opt. moisture content.					

## CONSOLIDATED UNDRAINED TRIAXIAL TEST

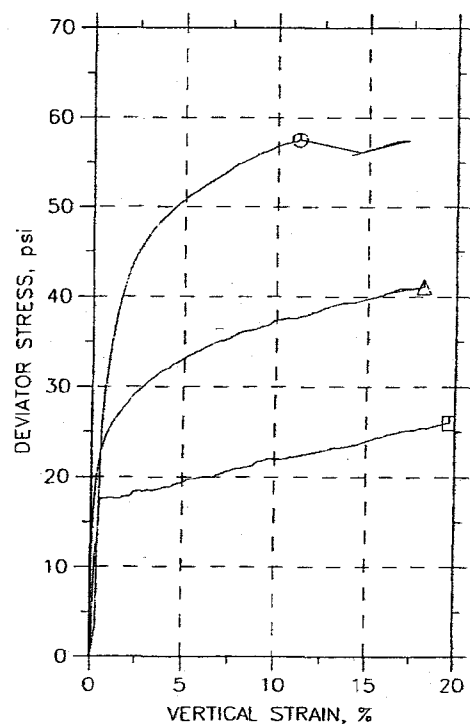
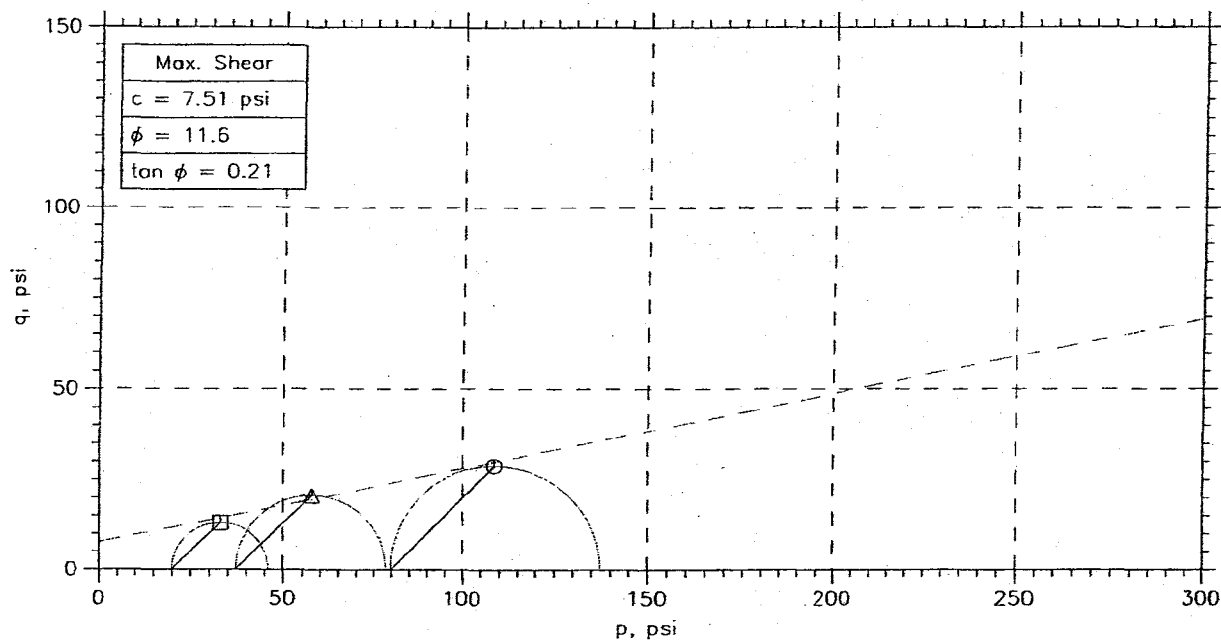

Symbol	⊙	△	□	
Sample No.	Bag	Bag	Bag	
Test No.	13924.3	13924.2	13924.1	
Depth	2-10 ft	2-10 ft	2-10 ft	
Initial	Diameter, in	2.87	2.87	2.87
	Height, in	6	6	6
	Water Content, %	27.5	27.6	27.3
	Dry Density, pcf	90.23	90.2	90.68
	Saturation, %	84.1	84.3	84.3
Before Shear	Void Ratio	0.896	0.896	0.886
	Water Content, %	29.4	30.4	30.8
	Dry Density, pcf	94.76	93.33	92.76
	Saturation*, %	100.1	100.0	100.0
Void Ratio	0.805	0.833	0.844	
Back Press., psi	60	90	80.01	
Ver. Eff. Cons. Stress, psi	80	40	19.99	
Shear Strength, psi	28.76	20.54	12.97	
Strain at Failure, %	11.2	18.2	19.7	
Strain Rate, %/min	0.022	0.022	0.022	
B-Value	0.95	0.95	0.95	
Measured Specific Gravity	2.74	2.74	2.74	
Liquid Limit	72	72	72	
Plastic Limit	25	25	25	

<b>GeoTesting</b> <b>express</b> <small>the groundwork for success</small>	Project: TVA Kingston Gypsum Stack				
	Location: NB-25				
	Project No.: GTX-G0959				
	Boring No.: NB-25				
	Sample Type: Remolded				
	Description: Orange Brown Fat Clay				
Remarks: Remolded to 95% of Standard Proctor max. dry density and +2% opt. moisture content.					

Phase calculations based on start and end of test.

\* Saturation is set to 100% for phase calculations.

## CONSOLIDATED UNDRAINED TRIAXIAL TEST

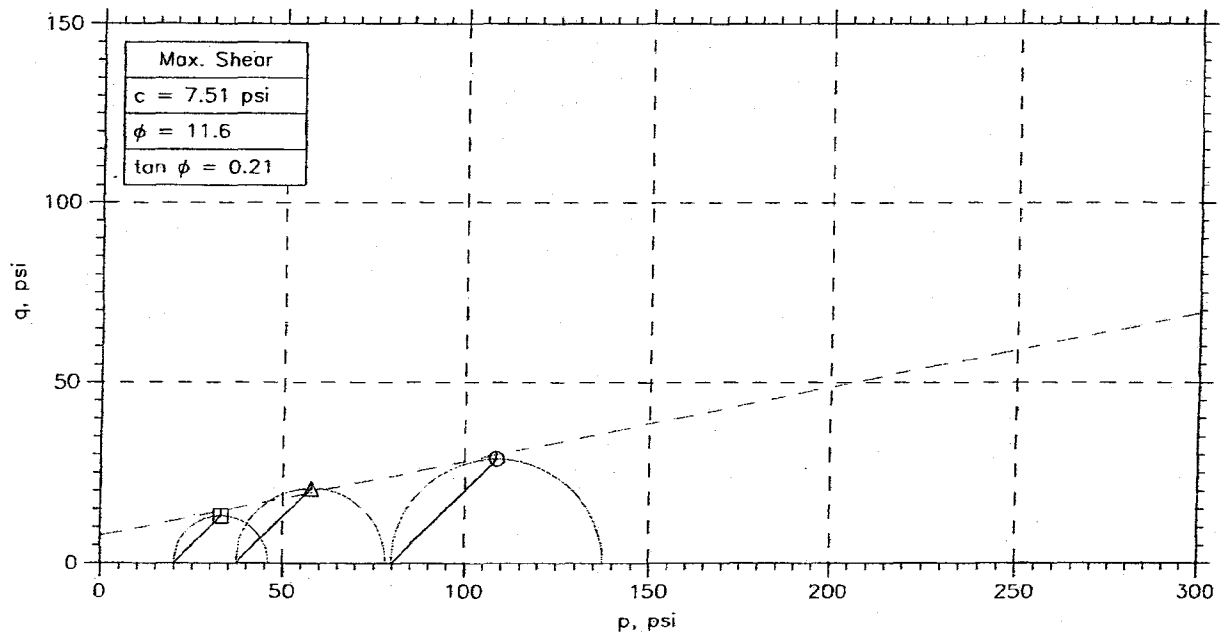
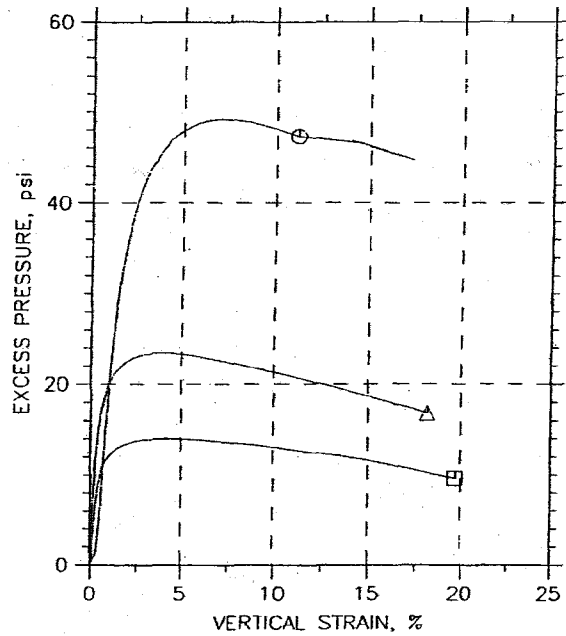
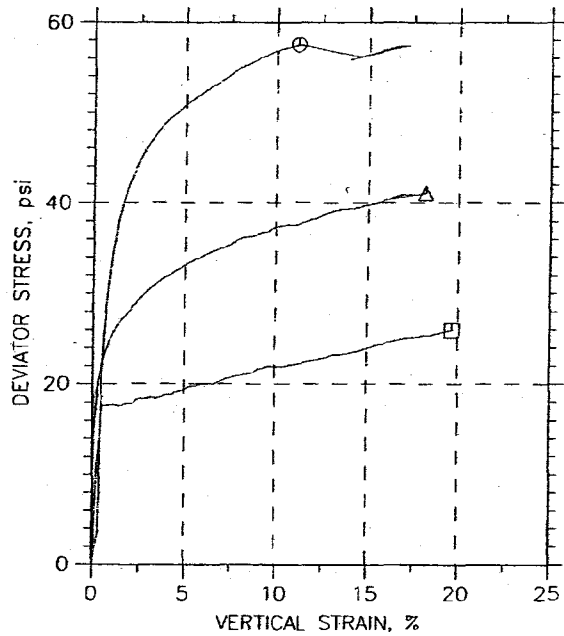

Sample No.	Test No.	Depth	Tested By	Test Date	Checked By	Check Date	Test File
⊙	Bog 13924.3	2-10 ft	JW	1/19/06	HJ		13924.3b_1062.dat
△	Bog 13924.2	2-10 ft	JW	1/19/05	HJ		13924.2_1057.dat
□	Bog 13924.1	2-10 ft	HJ	1/19/06	JW		13924.1a_2054.dat

<b>Geotesting</b> express the groundwork for success	Project: TVA Kingston Gypsum Station Location: NB-25		Project No.: GTX-G0959
	Boring No.: NB-25		Sample Type: Remolded
	Description: Orange Brown Fat Clay		
	Remarks: Remolded to 95% of Standard Proctor max. dry density and +2% opt. moisture content.		

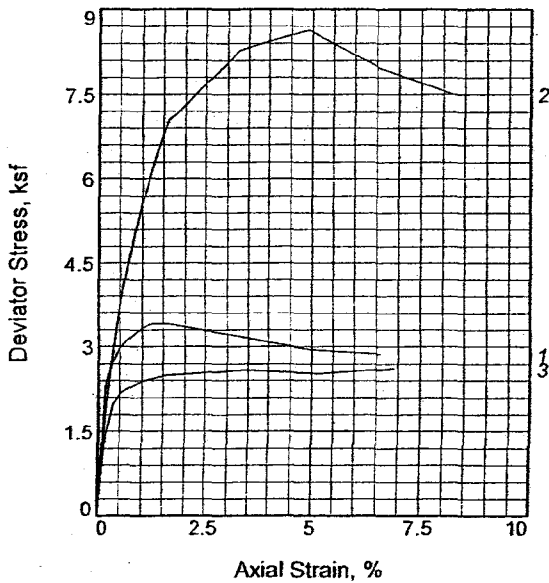
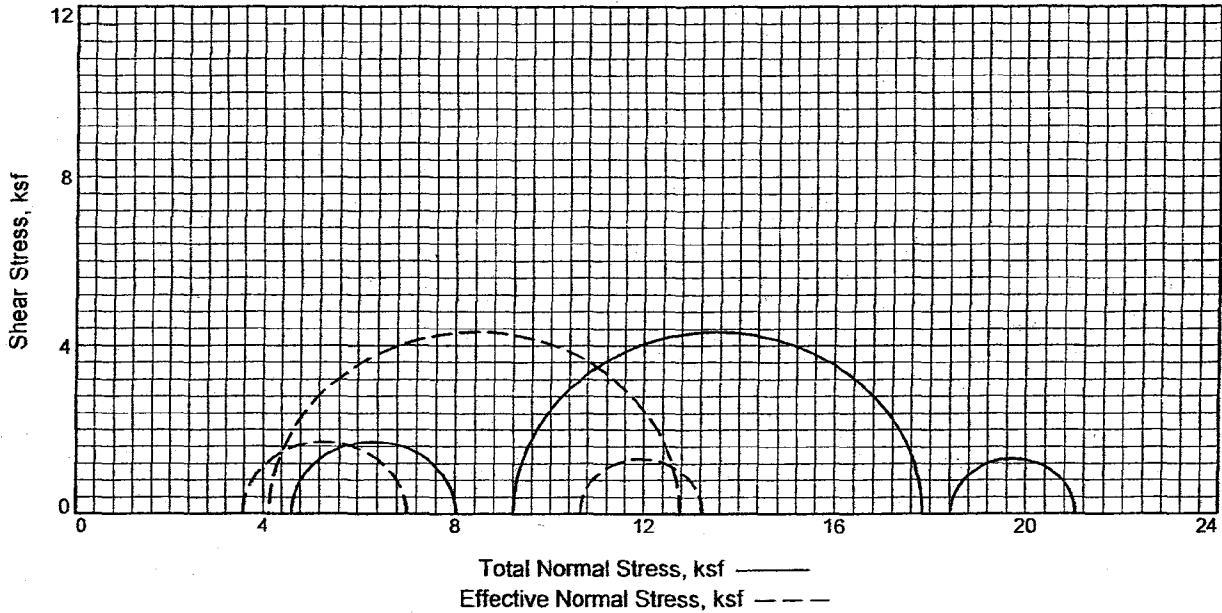

Sample No.		1	2	3
Initial	Water Content,	35.7	26.0	40.3
	Dry Density, pcf	84.6	89.5	78.3
	Saturation,	96.2	78.5	93.7
	Void Ratio	1.0137	0.9053	1.1753
	Diameter, in.	2.81	2.84	2.82
	Height, in.	6.14	6.31	6.14
At Test	Water Content,	34.2	26.3	29.8
	Dry Density, pcf	88.2	99.1	94.0
	Saturation,	100.0	100.0	100.0
	Void Ratio	0.9328	0.7193	0.8124
	Diameter, in.	2.78	2.74	2.66
	Height, in.	6.06	6.10	5.78
Strain rate, in./min.		0.02	0.02	0.02
Back Pressure, ksf		2.9	2.9	2.9
Cell Pressure, ksf		7.5	12.1	21.3
Fail. Stress, ksf		3.4	8.6	2.6
Total Pore Pr., ksf		3.9	7.9	10.7
Ult. Stress, ksf				
Total Pore Pr., ksf				
$\bar{\sigma}_1$ Failure, ksf		7.0	12.8	13.3
$\bar{\sigma}_3$ Failure, ksf		3.6	4.1	10.6

**Type of Test:**

CU with Pore Pressures

**Sample Type:** undisturbed

**Description:** Dark yellowish brown fat clay with sand

LL= 54      PL= 24      PI= 30

**Specific Gravity:** 2.73

**Remarks:** CH

**Client:** TVA

**Project:** TVA Kingston - Proposed Gypsum Stack

**Location:** NB-44

**Sample Number:** UD-3,4 & 5 (CU)      **Depth:** 19'-28.5'

**Proj. No.:** 3043051021      **Date:**

TRIAxIAL SHEAR TEST REPORT  
**MACTEC, INC.**

Figure \_\_\_\_\_

Tested By: Alexander

Checked By: Hamlett

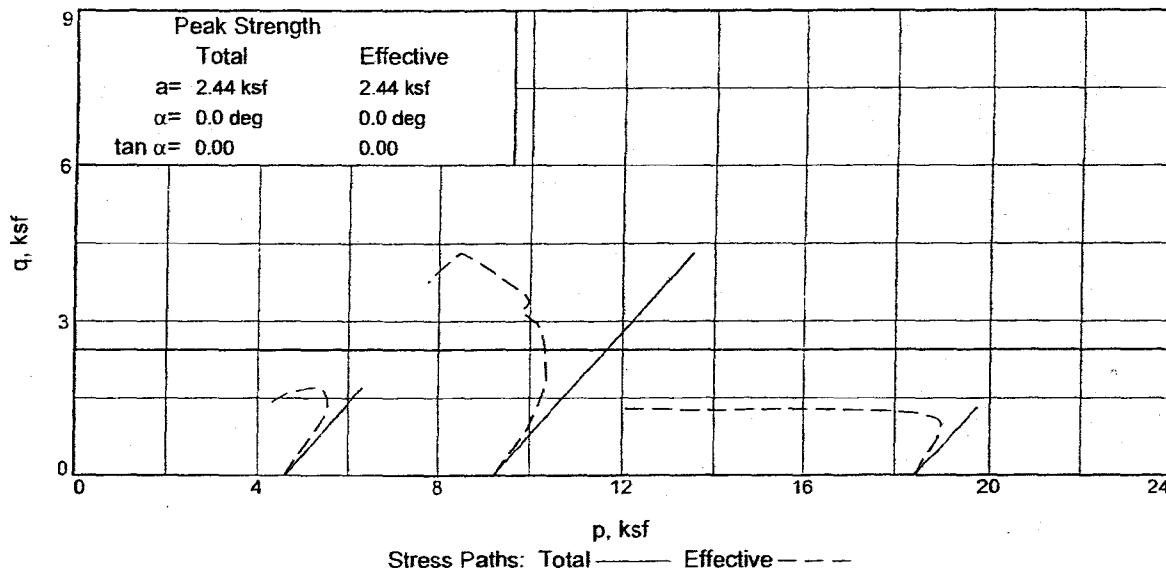
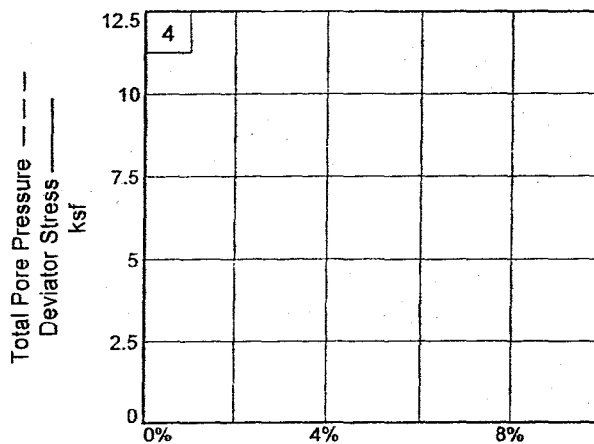
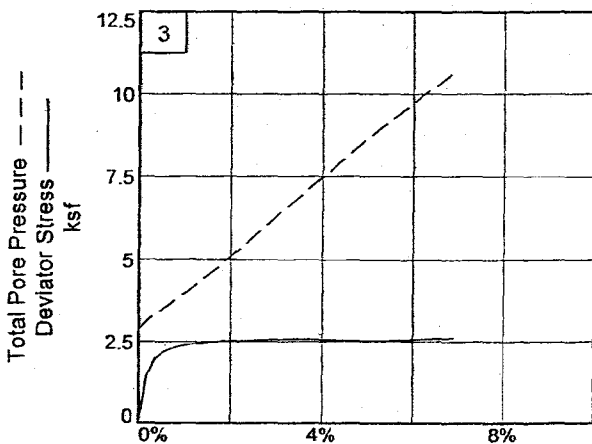
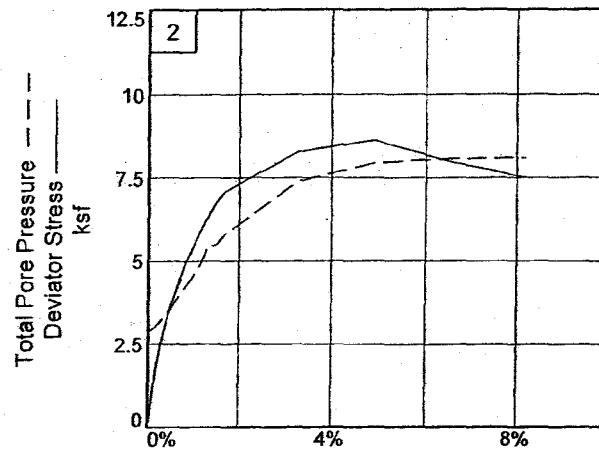
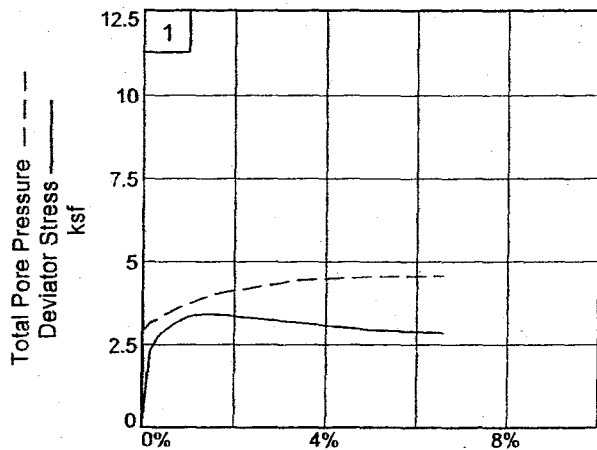

Client: TVA

Project: TVA Kingston - Proposed Gypsum Stack

Location: NB-44

Depth: 19'-28.5'

Sample Number: UD-3,4 & 5 (CU)

Project No.: 3043051021

Figure \_\_\_\_\_

**MACTEC, INC.**

Tested By: Alexander

Checked By: Hamlett





**Test Readings for Specimen No. 1**

No.	Def. Dial in.	Load Dial	Load lbs.	Strain %	Deviator Stress ksf	Minor Eff. Stress ksf	Major Eff. Stress ksf	1:3 Ratio	Pore Press. psi	P ksf	Q ksf
0	0.0000	0.0	0.0	0.0	0.00	4.58	4.58	1.00	20.20	4.58	0.00
1	0.0100	134.0	96.5	0.2	2.29	4.33	6.63	1.53	21.90	5.48	1.15
2	0.0200	159.0	114.5	0.3	2.72	4.20	6.92	1.65	22.80	5.56	1.36
3	0.0300	174.0	125.3	0.5	2.97	4.08	7.04	1.73	23.70	5.56	1.48
4	0.0400	183.0	131.8	0.7	3.11	3.96	7.07	1.79	24.50	5.52	1.56
5	0.0500	190.0	136.8	0.8	3.23	3.86	7.09	1.84	25.20	5.47	1.61
6	0.0600	196.0	141.1	1.0	3.32	3.76	7.08	1.88	25.90	5.42	1.66
7	0.0700	200.0	144.0	1.2	3.39	3.66	7.04	1.93	26.60	5.35	1.69
8	0.0800	202.0	145.4	1.3	3.42	3.59	7.00	1.95	27.10	5.29	1.71
9	0.0900	202.0	145.4	1.5	3.41	3.51	6.92	1.97	27.60	5.22	1.70
10	0.1000	202.0	145.4	1.7	3.40	3.44	6.85	1.99	28.10	5.14	1.70
11	0.2000	192.0	138.2	3.3	3.18	3.07	6.25	2.04	30.70	4.66	1.59
12	0.3000	181.0	130.3	5.0	2.95	2.94	5.89	2.00	31.60	4.41	1.47
13	0.4000	179.0	128.9	6.6	2.86	2.91	5.77	1.98	31.80	4.34	1.43

**Parameters for Specimen No. 1**

Specimen Parameter	Initial	Saturated	Consolidated	Final
Moisture content: Moist soil+tare, gms.	1158.610			1184.100
Moisture content: Dry soil+tare, gms.	919.300			922.720
Moisture content: Tare, gms.	0.000			14.290
Moisture, %	26.0	33.2	26.3	28.8
Moist specimen weight, gms.	1184.1			
Diameter, in.	2.84	2.84	2.74	
Area, in. <sup>2</sup>	6.34	6.34	5.92	
Height, in.	6.31	6.31	6.10	
Net decrease in height, in.		0.00	0.21	
Wet Density, pcf	112.7	119.1	125.2	
Dry density, pcf	89.5	89.5	99.1	
Void ratio	0.9053	0.9053	0.7193	
Saturation, %	78.5	100.0	100.0	

**Test Readings for Specimen No. 2**

Load ring constant = 0.72 lbs. per input unit  
 Consolidation cell pressure = 84.00 psi (12.10 ksf)  
 Consolidation back pressure = 20.00 psi (2.88 ksf)  
 Consolidation effective confining stress = 9.22 ksf  
 Strain rate, in./min. = 0.02  
 Fail. Stress = 8.63 ksf at reading no. 12

No.	Def. Dial in.	Load Dial	Load lbs.	Strain %	Deviator Stress ksf	Minor Eff. Stress ksf	Major Eff. Stress ksf	1:3 Ratio	Pore Press. psi	P ksf	Q ksf
0	0.0000	0.0	0.0	0.0	0.00	9.22	9.22	1.00	20.00	9.22	0.00
1	0.0100	104.0	74.9	0.2	1.82	9.04	10.86	1.20	21.20	9.95	0.91
2	0.0200	165.0	118.8	0.3	2.88	8.78	11.67	1.33	23.00	10.22	1.44
3	0.0300	211.0	151.9	0.5	3.68	8.51	12.19	1.43	24.90	10.35	1.84
4	0.0400	251.0	180.7	0.7	4.37	8.15	12.52	1.54	27.40	10.33	2.18
5	0.0500	287.0	206.6	0.8	4.99	7.82	12.81	1.64	29.70	10.31	2.49
6	0.0600	316.0	227.5	1.0	5.48	7.52	13.00	1.73	31.80	10.26	2.74
7	0.0700	342.0	246.2	1.1	5.92	7.19	13.11	1.82	34.10	10.15	2.96

**Test Reading for Specimen No. 2**

No.	Def. Dial in.	Load Dial	Load lbs.	Strain %	Deviator Stress ksf	Minor Eff. Stress ksf	Major Eff. Stress ksf	1:3 Ratio	Pore Press. psi	P ksf	Q ksf
8	0.0800	368.0	265.0	1.3	6.36	6.62	12.99	1.96	38.00	9.81	3.18
9	0.0900	390.0	280.8	1.5	6.73	6.62	13.36	2.02	38.00	9.99	3.37
10	0.1000	409.0	294.5	1.6	7.05	6.35	13.40	2.11	39.90	9.87	3.52
11	0.2000	488.0	351.4	3.3	8.27	4.71	12.98	2.76	51.30	8.84	4.14
12	0.3000	518.0	373.0	4.9	8.63	4.15	12.78	3.08	55.20	8.46	4.31
13	0.4000	487.0	350.6	6.6	7.97	4.02	11.99	2.98	56.10	8.00	3.99
14	0.5000	467.0	336.2	8.2	7.51	4.00	11.52	2.88	56.20	7.76	3.76

**Parameters for Specimen No. 2**

Specimen Parameter	Initial	Saturated	Consolidated	Final
Moisture content: Moist soil+tare, gms.	1101.080			678.520
Moisture content: Dry soil+tare, gms.	784.600			483.890
Moisture content: Tare, gms.	0.000			13.830
Moisture, %	40.3	43.1	29.8	41.4
Moist specimen weight, gms.	1109.4			
Diameter, in.	2.82	2.82	2.66	
Area, in. <sup>2</sup>	6.26	6.26	5.54	
Height, in.	6.14	6.14	5.78	
Net decrease in height, in.		0.00	0.35	
Wet Density, pcf	109.9	112.1	122.0	
Dry density, pcf	78.3	78.3	94.0	
Void ratio	1.1753	1.1753	0.8124	
Saturation, %	93.7	100.0	100.0	

**Parameters for Specimen No. 3**

Load ring constant = 0.72 lbs. per input unit  
 Consolidation cell pressure = 148.00 psi (21.31 ksf)  
 Consolidation back pressure = 20.00 psi (2.88 ksf)  
 Consolidation effective confining stress = 18.43 ksf  
 Strain rate, in./min. = 0.02  
 Fail. Stress = 2.61 ksf at reading no. 13

No.	Def. Dial in.	Load Dial	Load lbs.	Strain %	Deviator Stress ksf	Minor Eff. Stress ksf	Major Eff. Stress ksf	1:3 Ratio	Pore Press. psi	P ksf	Q ksf
0	0.0000	0.0	0.0	0.0	0.00	18.43	18.43	1.00	20.00	18.43	0.00
1	0.0100	76.0	54.7	0.2	1.42	18.17	19.59	1.08	21.80	18.88	0.71
2	0.0200	106.0	76.3	0.3	1.98	17.99	19.96	1.11	23.10	18.97	0.99
3	0.0300	117.0	84.2	0.5	2.18	17.81	19.99	1.12	24.30	18.90	1.09
4	0.0400	122.0	87.8	0.7	2.27	17.65	19.92	1.13	25.40	18.79	1.13
5	0.0500	126.0	90.7	0.9	2.34	17.47	19.81	1.13	26.70	18.64	1.17
6	0.0600	129.0	92.9	1.0	2.39	17.31	19.70	1.14	27.80	18.50	1.19
7	0.0700	131.0	94.3	1.2	2.42	17.12	19.54	1.14	29.10	18.33	1.21
8	0.0800	133.0	95.8	1.4	2.46	16.91	19.36	1.15	30.60	18.13	1.23
9	0.0900	135.0	97.2	1.6	2.49	16.72	19.21	1.15	31.90	17.96	1.24
10	0.1000	136.0	97.9	1.7	2.50	16.56	19.06	1.15	33.00	17.81	1.25
11	0.2000	143.0	103.0	3.5	2.58	14.49	17.07	1.18	47.40	15.78	1.29
12	0.3000	142.0	102.2	5.2	2.52	12.44	14.96	1.20	61.60	13.70	1.26
13	0.4000	150.0	108.0	6.9	2.61	10.64	13.26	1.25	74.10	11.95	1.31

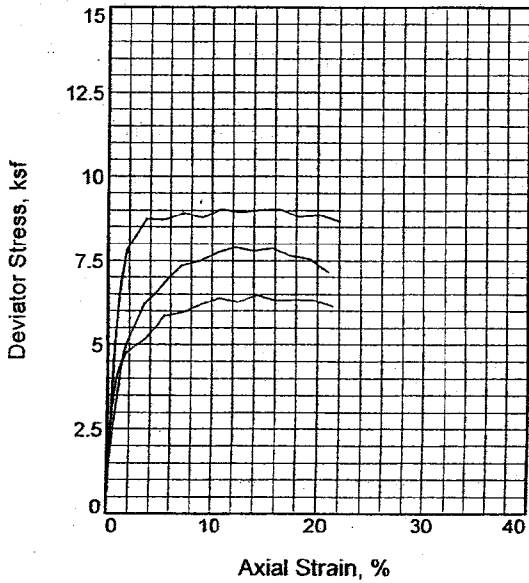
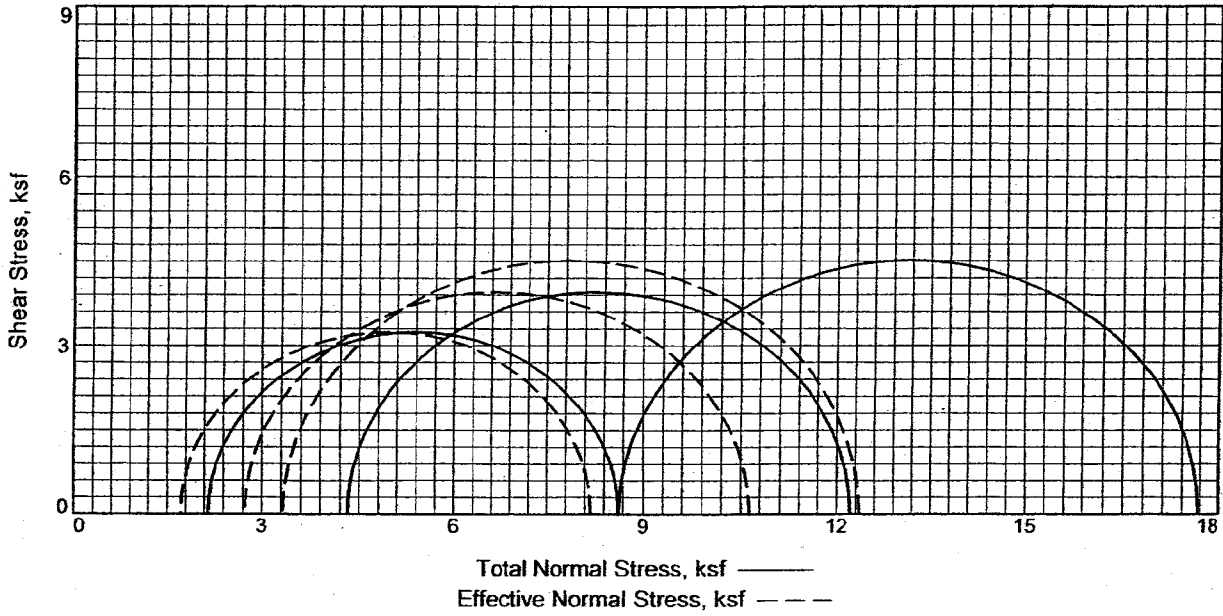

Sample No.		1	2	3
Initial	Water Content,	35.4	27.6	27.2
	Dry Density, pcf	84.0	96.1	93.1
	Saturation,	94.1	97.9	89.9
	Void Ratio	1.0223	0.7675	0.8235
	Diameter, in.	2.82	2.79	2.84
	Height, in.	5.99	5.90	5.66
At Test	Water Content,	23.3	21.9	23.5
	Dry Density, pcf	103.9	106.3	103.6
	Saturation,	100.0	100.0	100.0
	Void Ratio	0.6341	0.5970	0.6393
	Diameter, in.	2.62	2.70	2.74
	Height, in.	5.58	5.71	5.46
Strain rate, in./min.		0.02	0.02	0.02
Back Pressure, ksf		5.8	5.8	5.8
Cell Pressure, ksf		7.9	10.1	14.4
Fail. Stress, ksf		6.5	7.9	9.0
Total Pore Pr., ksf		6.2	7.3	11.1
Ult. Stress, ksf				
Total Pore Pr., ksf				
$\bar{\sigma}_1$ Failure, ksf		8.2	10.6	12.4
$\bar{\sigma}_3$ Failure, ksf		1.7	2.7	3.3

**Type of Test:**

CU with Pore Pressures

**Sample Type:** undisturbed

**Description:** Brown elastic silt with sand

LL= 51      PL= 30      PI= 21

**Specific Gravity=** 2.72

**Remarks:** MH

**Client:** TVA

**Project:** TVA Kingston - Proposed Gypsum Stack

**Location:** NB-47A

**Sample Number:** UD-1, 2 & 3 (CU)

**Depth:** 9'-17'

**Proj. No.:** 3043051021

**Date:**

TRIAXIAL SHEAR TEST REPORT

**MACTEC, INC.**

Figure \_\_\_\_\_

Tested By: Alexander

Checked By: Hamlett

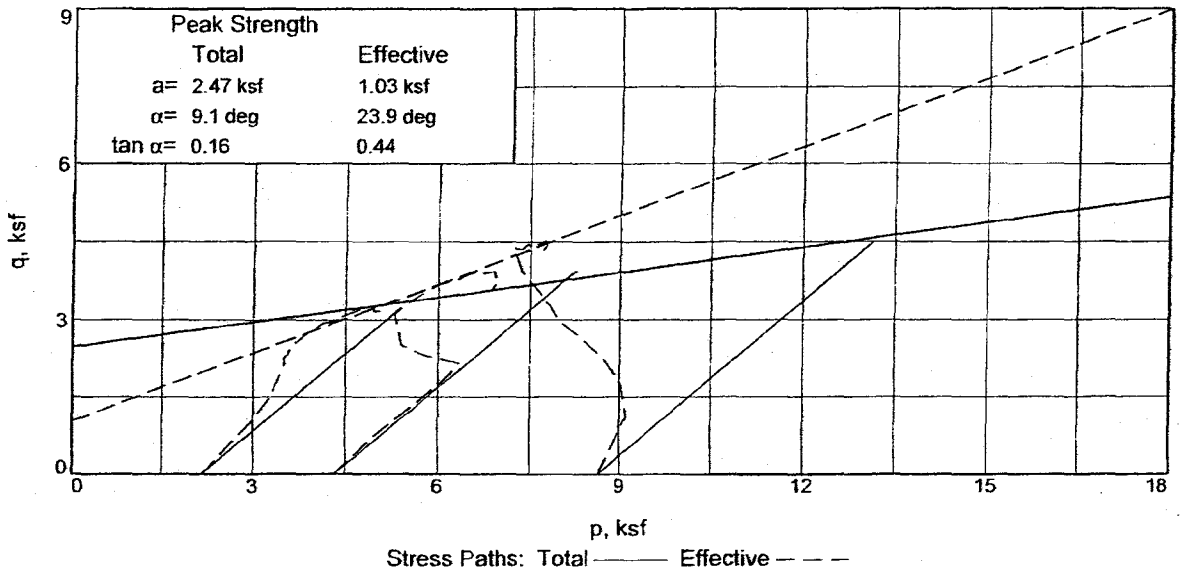
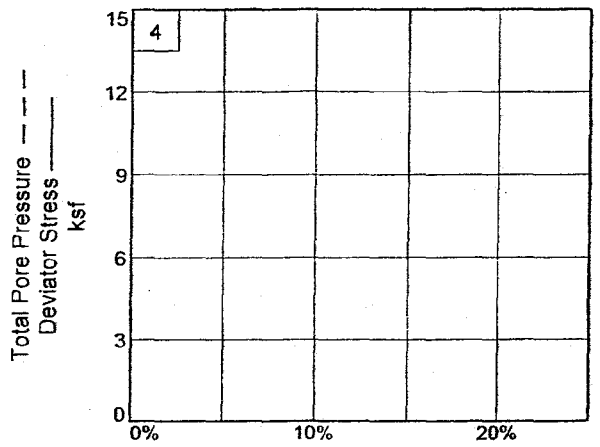
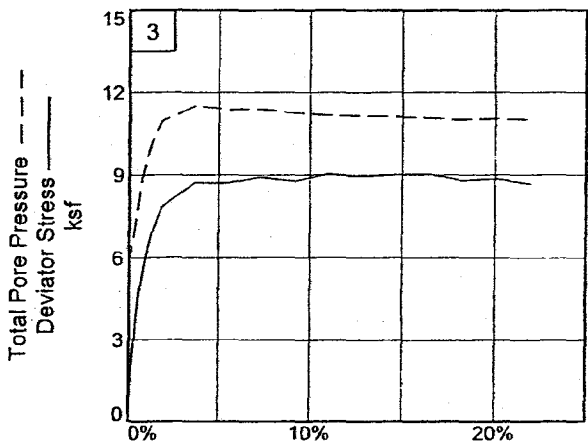
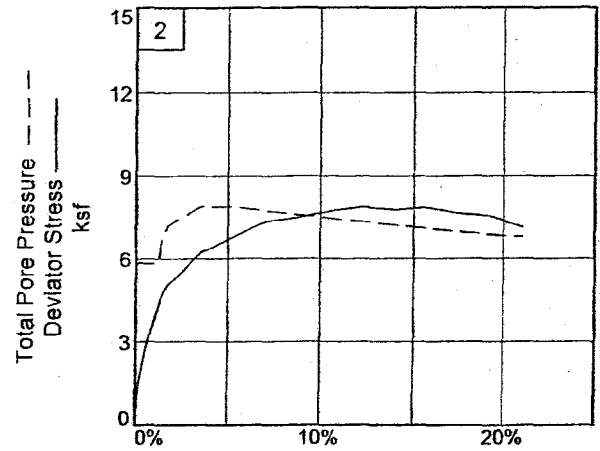
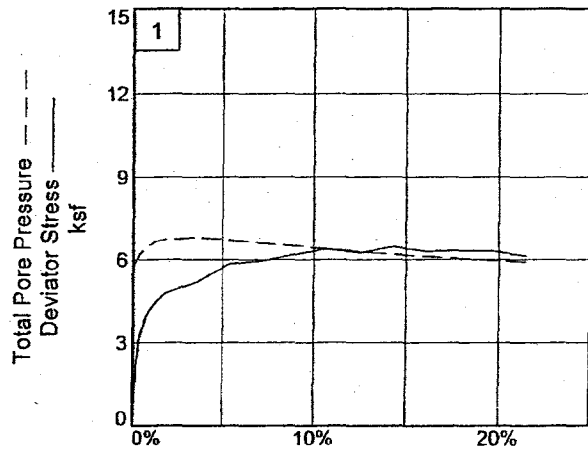

**Client:** TVA  
**Project:** TVA Kingston - Proposed Gypsum Stack  
**Location:** NB-47A      **Depth:** 9'-17'      **Sample Number:** UD-1, 2 & 3 (CU)  
**Project No.:** 3043051021      **Figure** \_\_\_\_\_      **MACTEC, INC.**

**Tested By:** Alexander \_\_\_\_\_      **Checked By:** Hamlett \_\_\_\_\_



TEST REPORT OF SPECIMEN No.

No.	Def. Dial in.	Load Dial	Load lbs.	Strain %	Deviator Stress ksf	Minor Eff. Stress ksf	Major Eff. Stress ksf	1:3 Ratio	Pore Press. psi	P ksf	Q ksf
0	0.0000	0.0	0.0	0.0	0.00	2.16	2.16	1.00	40.00	2.16	0.00
1	0.0100	110.0	79.2	0.2	2.11	1.94	4.05	2.09	41.50	3.00	1.06
2	0.0200	161.0	115.9	0.4	3.08	1.76	4.84	2.76	42.80	3.30	1.54
3	0.0300	183.0	131.8	0.5	3.50	1.61	5.11	3.17	43.80	3.36	1.75
4	0.0400	204.0	146.9	0.7	3.89	1.50	5.39	3.60	44.60	3.44	1.95
5	0.0500	216.0	155.5	0.9	4.11	1.41	5.53	3.92	45.20	3.47	2.06
6	0.0600	226.0	162.7	1.1	4.30	1.35	5.65	4.17	45.60	3.50	2.15
7	0.0700	234.0	168.5	1.3	4.44	1.27	5.71	4.51	46.20	3.49	2.22
8	0.0800	240.0	172.8	1.4	4.55	1.24	5.79	4.67	46.40	3.51	2.27
9	0.0900	248.0	178.6	1.6	4.69	1.22	5.91	4.83	46.50	3.57	2.35
10	0.1000	253.0	182.2	1.8	4.78	1.18	5.96	5.04	46.80	3.57	2.39
11	0.2000	279.0	200.9	3.6	5.17	1.12	6.29	5.60	47.20	3.71	2.59
12	0.3000	321.0	231.1	5.4	5.84	1.20	7.03	5.89	46.70	4.11	2.92
13	0.4000	333.0	239.8	7.2	5.94	1.31	7.25	5.54	45.90	4.28	2.97
14	0.5000	353.0	254.2	9.0	6.18	1.43	7.60	5.33	45.10	4.51	3.09
15	0.6000	372.0	267.8	10.7	6.38	1.53	7.91	5.18	44.40	4.72	3.19
16	0.7000	372.0	267.8	12.5	6.25	1.63	7.88	4.84	43.70	4.75	3.13
17	0.8000	393.0	283.0	14.3	6.47	1.73	8.20	4.75	43.00	4.96	3.24
18	0.9000	391.0	281.5	16.1	6.30	1.80	8.10	4.50	42.50	4.95	3.15
19	1.0000	401.0	288.7	17.9	6.33	1.87	8.20	4.38	42.00	5.04	3.16
20	1.1000	409.0	294.5	19.7	6.31	1.94	8.26	4.25	41.50	5.10	3.16
21	1.2000	406.0	292.3	21.5	6.13	2.02	8.14	4.04	41.00	5.08	3.06

MACTEC, INC.

Specimen Parameter	Initial	Saturated	Consolidated	Final
Moisture content: Moist soil+tare, gms.	1158.000			627.200
Moisture content: Dry soil+tare, gms.	907.300			492.760
Moisture content: Tare, gms.	0.000			13.740
Moisture, %	27.6	28.2	21.9	28.1
Moist specimen weight, gms.	1162.2			
Diameter, in.	2.79	2.79	2.70	
Area, in. <sup>2</sup>	6.12	6.12	5.72	
Height, in.	5.90	5.90	5.71	
Net decrease in height, in.		0.00	0.19	
Wet Density, pcf	122.6	123.2	129.7	
Dry density, pcf	96.1	96.1	106.3	
Void ratio	0.7675	0.7675	0.5970	
Saturation, %	97.9	100.0	100.0	

Load ring constant = 0.72 lbs. per input unit

Consolidation cell pressure = 70.00 psi (10.08 ksf)

Consolidation back pressure = 40.00 psi (5.76 ksf)

Consolidation effective confining stress = 4.32 ksf

Strain rate, in./min. = 0.02

Fail. Stress = 7.89 ksf at reading no. 16

No.	Def. Dial in.	Load Dial	Load lbs.	Strain %	Deviator Stress ksf	Minor Eff. Stress ksf	Major Eff. Stress ksf	1:3 Ratio	Pore Press. psi	P ksf	Q ksf
0	0.0000	0.0	0.0	0.0	0.00	4.32	4.32	1.00	40.00	4.32	0.00
1	0.0100	81.0	58.3	0.2	1.47	4.22	5.69	1.35	40.70	4.95	0.73
2	0.0200	116.0	83.5	0.4	2.10	4.23	6.33	1.50	40.60	5.28	1.05
3	0.0300	147.0	105.8	0.5	2.65	4.25	6.90	1.62	40.50	5.57	1.33
4	0.0400	174.0	125.3	0.7	3.13	4.26	7.40	1.74	40.40	5.83	1.57
5	0.0500	196.0	141.1	0.9	3.52	4.26	7.79	1.83	40.40	6.02	1.76
6	0.0600	219.0	157.7	1.1	3.93	4.23	8.16	1.93	40.60	6.20	1.97
7	0.0700	240.0	172.8	1.2	4.30	4.18	8.48	2.03	41.00	6.33	2.15
8	0.0800	259.0	186.5	1.4	4.63	3.46	8.09	2.34	46.00	5.77	2.32
9	0.0900	273.0	196.6	1.6	4.87	3.11	7.98	2.57	48.40	5.55	2.44
10	0.1000	282.0	203.0	1.8	5.03	2.88	7.91	2.75	50.00	5.39	2.51
11	0.2000	355.0	255.6	3.5	6.21	2.19	8.40	3.84	54.80	5.30	3.11
12	0.3000	394.0	283.7	5.3	6.77	2.19	8.96	4.09	54.80	5.57	3.39
13	0.4000	436.0	313.9	7.0	7.35	2.33	9.69	4.15	53.80	6.01	3.68
14	0.5000	452.0	325.4	8.8	7.48	2.48	9.96	4.02	52.80	6.22	3.74
15	0.6000	476.0	342.7	10.5	7.73	2.61	10.33	3.96	51.90	6.47	3.86
16	0.7000	496.0	357.1	12.3	7.89	2.74	10.63	3.89	51.00	6.68	3.95
17	0.8000	499.0	359.3	14.0	7.78	2.85	10.63	3.73	50.20	6.74	3.89
18	0.9000	515.0	370.8	15.8	7.87	2.98	10.85	3.64	49.30	6.92	3.93
19	1.0000	511.0	367.9	17.5	7.65	3.10	10.74	3.47	48.50	6.92	3.82
20	1.1000	516.0	371.5	19.3	7.56	3.21	10.77	3.35	47.70	6.99	3.78
21	1.2000	499.0	359.3	21.0	7.15	3.28	10.43	3.18	47.20	6.86	3.57

Specimen Parameter	Initial	Saturated	Consolidated	Final
Moisture content: Moist soil+tare, gms.	1089.500			655.220
Moisture content: Dry soil+tare, gms.	856.500			506.180
Moisture content: Tare, gms.	0.000			13.570
Moisture, %	27.2	30.3	23.5	30.3
Moist specimen weight, gms.	1116.2			
Diameter, in.	2.84	2.84	2.74	
Area, in. <sup>2</sup>	6.34	6.34	5.91	
Height, in.	5.66	5.66	5.46	
Net decrease in height, in.		0.00	0.20	
Wet Density, pcf	118.5	121.3	127.9	
Dry density, pcf	93.1	93.1	103.6	
Void ratio	0.8235	0.8235	0.6393	
Saturation, %	89.9	100.0	100.0	

Load ring constant = 0.72 lbs. per input unit  
 Consolidation cell pressure = 100.00 psi (14.40 ksf)  
 Consolidation back pressure = 40.00 psi (5.76 ksf)  
 Consolidation effective confining stress = 8.64 ksf  
 Strain rate, in./min. = 0.02  
 Fail. Stress = 9.03 ksf at reading no. 18

No.	Def. Dial in.	Load Dial	Load lbs.	Strain %	Deviator Stress ksf	Minor Eff. Stress ksf	Major Eff. Stress ksf	1:3 Ratio	Pore Press. psi	P ksf	Q ksf
0	0.0000	0.0	0.0	0.0	0.00	8.64	8.64	1.00	40.00	8.64	0.00
1	0.0100	127.0	91.4	0.2	2.23	7.99	10.22	1.28	44.50	9.10	1.11
2	0.0200	200.0	144.0	0.4	3.50	7.27	10.77	1.48	49.50	9.02	1.75
3	0.0300	261.0	187.9	0.5	4.56	6.44	10.99	1.71	55.30	8.71	2.28
4	0.0400	308.0	221.8	0.7	5.37	5.62	10.98	1.96	61.00	8.30	2.68
5	0.0500	340.0	244.8	0.9	5.91	5.05	10.97	2.17	64.90	8.01	2.96
6	0.0600	375.0	270.0	1.1	6.51	4.59	11.10	2.42	68.10	7.85	3.26
7	0.0700	400.0	288.0	1.3	6.93	4.23	11.17	2.64	70.60	7.70	3.47
8	0.0800	420.0	302.4	1.5	7.26	3.96	11.22	2.83	72.50	7.59	3.63
9	0.0900	439.0	316.1	1.6	7.58	3.67	11.25	3.06	74.50	7.46	3.79
10	0.1000	455.0	327.6	1.8	7.84	3.46	11.30	3.27	76.00	7.38	3.92
11	0.2000	516.0	371.5	3.7	8.73	2.88	11.61	4.03	80.00	7.24	4.36
12	0.3000	525.0	378.0	5.5	8.71	3.01	11.72	3.89	79.10	7.36	4.35
13	0.4000	548.0	394.6	7.3	8.92	3.01	11.92	3.96	79.10	7.47	4.46
14	0.5000	550.0	396.0	9.2	8.77	3.12	11.90	3.81	78.30	7.51	4.39
15	0.6000	578.0	416.2	11.0	9.03	3.24	12.27	3.79	77.50	7.76	4.52
16	0.7000	584.0	420.5	12.8	8.94	3.25	12.19	3.75	77.40	7.72	4.47
17	0.8000	601.0	432.7	14.6	9.01	3.28	12.29	3.74	77.20	7.79	4.50
18	0.9000	616.0	443.5	16.5	9.03	3.33	12.36	3.72	76.90	7.84	4.52
19	1.0000	613.0	441.4	18.3	8.79	3.38	12.18	3.60	76.50	7.78	4.40
20	1.1000	632.0	455.0	20.1	8.86	3.36	12.22	3.64	76.70	7.79	4.43
21	1.2000	633.0	455.8	22.0	8.67	3.38	12.06	3.56	76.50	7.72	4.34



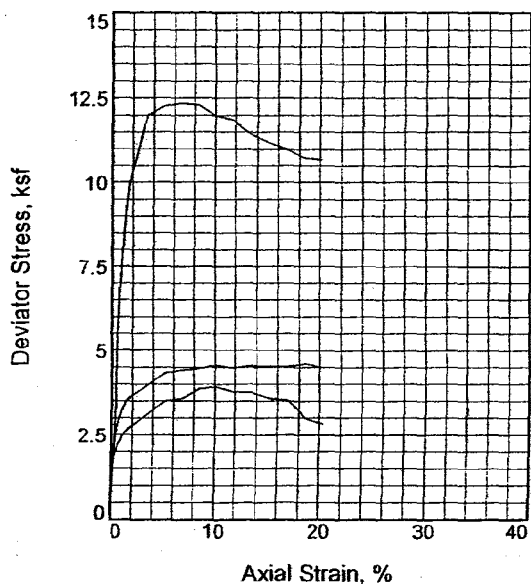
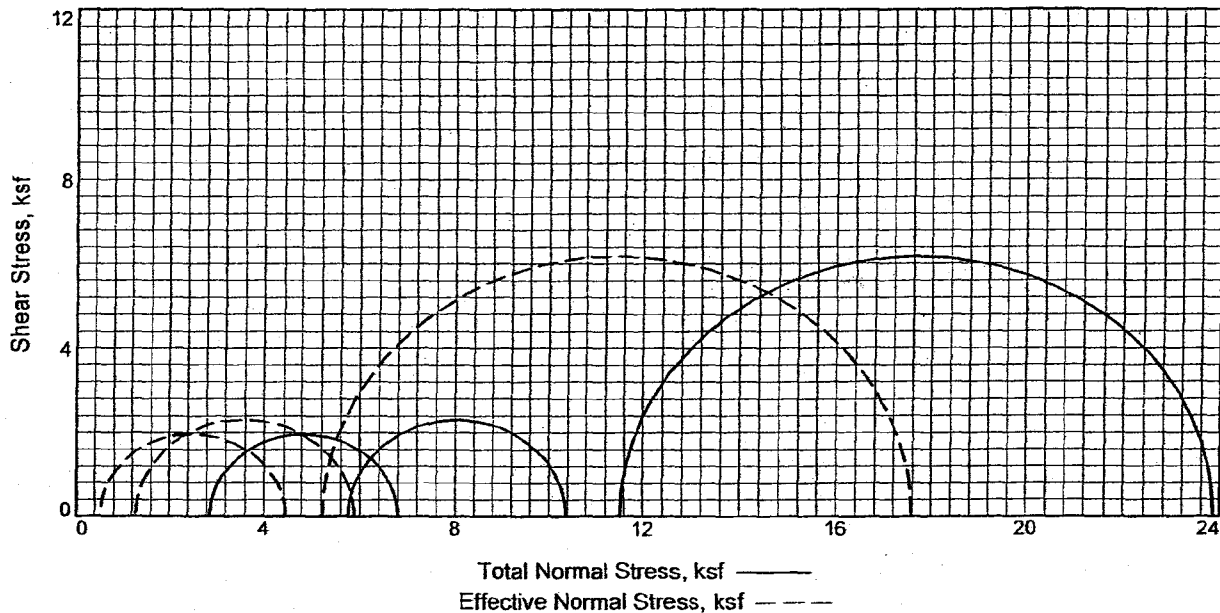

Sample No.	1	2	3
<b>Initial</b>			
Water Content,	34.3	30.5	30.5
Dry Density, pcf	83.5	87.6	85.3
Saturation,	90.2	88.3	83.9
Void Ratio	1.0327	0.9385	0.9897
Diameter, in.	2.82	2.82	2.82
Height, in.	6.01	6.03	6.12
<b>At Test</b>			
Water Content,	33.5	29.8	30.6
Dry Density, pcf	88.9	93.8	92.7
Saturation,	100.0	100.0	100.0
Void Ratio	0.9106	0.8112	0.8327
Diameter, in.	2.77	2.76	2.74
Height, in.	5.89	5.89	5.96
Strain rate, in./min.	0.02	0.02	0.02
Back Pressure, ksf	2.9	2.9	2.9
Cell Pressure, ksf	5.8	8.6	14.4
Fail. Stress, ksf	3.9	4.6	12.3
Total Pore Pr., ksf	5.2	7.4	9.2
Ult. Stress, ksf			
Total Pore Pr., ksf			
$\bar{\sigma}_1$ Failure, ksf	4.4	5.9	17.6
$\bar{\sigma}_3$ Failure, ksf	0.5	1.3	5.2

**Type of Test:**  
CU with Pore Pressures

**Sample Type:** undisturbed

**Description:** Brown sandy elastic silt

LL= 58      PL= 34      PI= 24

**Specific Gravity=** 2.72

**Remarks:** MH

**Client:** TVA

**Project:** TVA Kingston - Proposed Gypsum Stack

**Location:** NB-47A

**Sample Number:** UD-4, 5 & 6 (CU)      **Depth:** 18'-27'

**Proj. No.:** 3043051021      **Date:**

TRIAXIAL SHEAR TEST REPORT  
**MACTEC, INC.**

Figure \_\_\_\_\_

Tested By: Alexander

Checked By: Hamlett

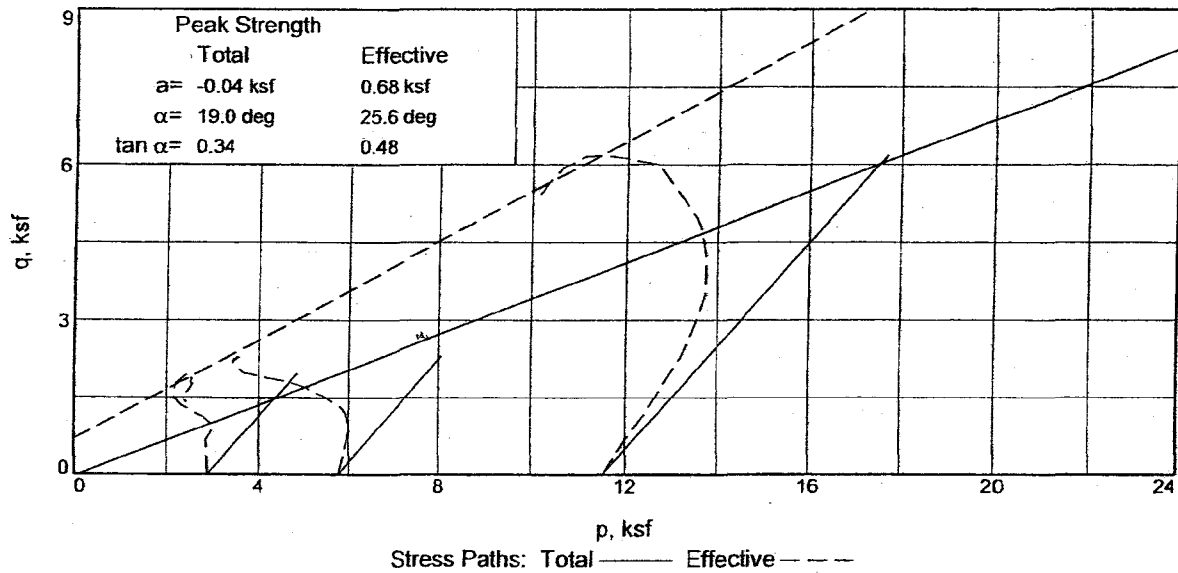
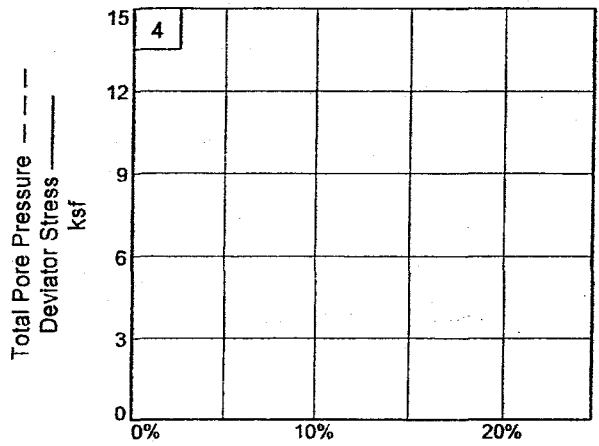
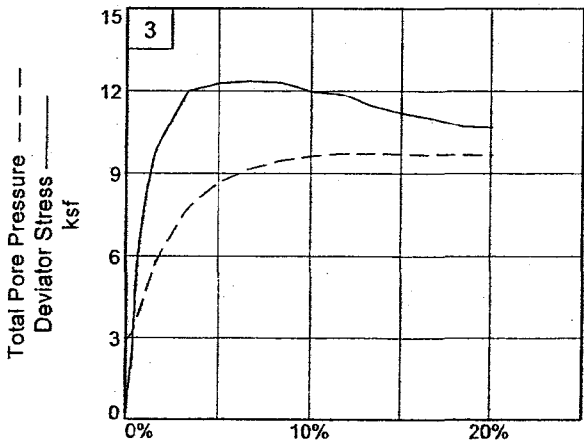
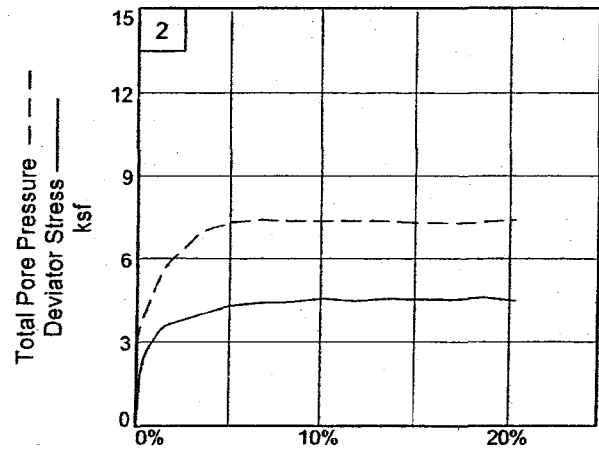
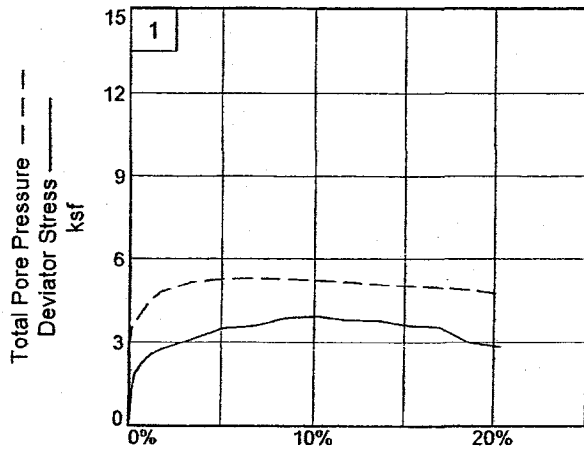

Client: TVA

Project: TVA Kingston - Proposed Gypsum Stack

Location: NB-47A

Depth: 18'-27"

Sample Number: UD-4, 5 & 6 (CU)

Project No.: 3043051021

Figure \_\_\_\_\_

**MACTEC, INC.**

Tested By: Alexander

Checked By: Hamlett

**TRIAXIAL COMPRESSION TEST**  
CU with Pore Pressures

9/16/2005  
10:50 AM

**Date:**  
**Client:** TVA  
**Project:** TVA Kingston - Proposed Gypsum Stack  
**Project No.:** 3043051021  
**Location:** NB-47A  
**Depth:** 18'-27' **Sample Number:** UD-4, 5 & 6 (CU)  
**Description:** Brown sandy elastic silt  
**Remarks:** MH  
**Type of Sample:** undisturbed  
**Specific Gravity**=2.72 **LL**=58 **PL**=34 **PI**=24  
**Test Method:** COE uniform strain

Parameters for Specimen No. 1				
Specimen Parameter	Initial	Saturated	Consolidated	Final
Moisture content: Moist soil+tare, gms.	1130.900			1121.520
Moisture content: Dry soil+tare, gms.	842.300			852.460
Moisture content: Tare, gms.	0.000			13.660
Moisture, %	34.3	38.0	33.5	32.1
Moist specimen weight, gms.	1108.5			
Diameter, in.	2.82	2.82	2.77	
Area, in. <sup>2</sup>	6.26	6.26	6.01	
Height, in.	6.01	6.01	5.89	
Net decrease in height, in.		0.00	0.12	
Wet Density, pcf	112.2	115.3	118.6	
Dry density, pcf	83.5	83.5	88.9	
Void ratio	1.0327	1.0327	0.9106	
Saturation, %	90.2	100.0	100.0	

**Test Results for Specimen No. 1**

Load ring constant = 0.72 lbs. per input unit  
 Consolidation cell pressure = 40.00 psi (5.76 ksf)  
 Consolidation back pressure = 20.00 psi (2.88 ksf)  
 Consolidation effective confining stress = 2.88 ksf  
 Strain rate, in./min. = 0.02  
 Fail. Stress = 3.92 ksf at reading no. 15

TEST RESULTS FOR SPECIMEN NO. 1

No.	Def. Dial in.	Load Dial	Load lbs.	Strain %	Deviator Stress ksf	Minor Eff. Stress ksf	Major Eff. Stress ksf	1:3 Ratio	Pore Press. psi	P ksf	Q ksf
0	0.0000	0.0	0.0	0.0	0.00	2.88	2.88	1.00	20.00	2.88	0.00
1	0.0100	78.0	56.2	0.2	1.34	2.19	3.53	1.61	24.80	2.86	0.67
2	0.0200	107.0	77.0	0.3	1.84	2.10	3.94	1.88	25.40	3.02	0.92
3	0.0300	121.0	87.1	0.5	2.08	1.87	3.95	2.11	27.00	2.91	1.04
4	0.0400	131.0	94.3	0.7	2.24	1.67	3.92	2.34	28.40	2.79	1.12
5	0.0500	136.0	97.9	0.8	2.33	1.53	3.85	2.52	29.40	2.69	1.16
6	0.0600	143.0	103.0	1.0	2.44	1.37	3.81	2.79	30.50	2.59	1.22
7	0.0750	151.0	108.7	1.3	2.57	1.20	3.77	3.15	31.70	2.48	1.29
8	0.0800	152.0	109.4	1.4	2.59	1.15	3.74	3.25	32.00	2.45	1.29
9	0.0900	156.0	112.3	1.5	2.65	1.07	3.72	3.49	32.60	2.39	1.33
10	0.1000	159.0	114.5	1.7	2.70	0.98	3.68	3.75	33.20	2.33	1.35
11	0.2000	185.0	133.2	3.4	3.08	0.59	3.67	6.22	35.90	2.13	1.54
12	0.3000	213.0	153.4	5.1	3.49	0.48	3.96	8.34	36.70	2.22	1.74
13	0.4000	222.0	159.8	6.8	3.57	0.45	4.02	9.00	36.90	2.23	1.79
14	0.5000	244.0	175.7	8.5	3.85	0.48	4.33	9.11	36.70	2.40	1.93
15	0.6000	253.0	182.2	10.2	3.92	0.52	4.44	8.56	36.40	2.48	1.96
16	0.7000	248.0	178.6	11.9	3.77	0.59	4.36	7.39	35.90	2.48	1.89
17	0.8000	252.0	181.4	13.6	3.76	0.68	4.43	6.55	35.30	2.56	1.88
18	0.9000	245.0	176.4	15.3	3.58	0.73	4.32	5.88	34.90	2.52	1.79
19	1.0000	247.0	177.8	17.0	3.54	0.79	4.33	5.47	34.50	2.56	1.77
20	1.1000	212.0	152.6	18.7	2.97	0.88	3.85	4.39	33.90	2.37	1.49
21	1.2000	205.0	147.6	20.4	2.82	1.02	3.84	3.75	32.90	2.43	1.41

Specimen Parameter	Initial	Saturated	Consolidated	Final
Moisture content: Moist soil+tare, gms.	1171.700			1145.200
Moisture content: Dry soil+tare, gms.	898.100			908.160
Moisture content: Tare, gms.	0.000			13.550
Moisture, %	30.5	34.5	29.8	26.5
Moist specimen weight, gms.	1132.8			
Diameter, in.	2.82	2.82	2.76	
Area, in. <sup>2</sup>	6.26	6.26	5.99	
Height, in.	6.03	6.03	5.89	
Net decrease in height, in.		0.00	0.13	
Wet Density, pcf	114.3	117.8	121.7	
Dry density, pcf	87.6	87.6	93.8	
Void ratio	0.9385	0.9385	0.8112	
Saturation, %	88.3	100.0	100.0	

Test Results for Specimen No. 2

Load ring constant = 0.72 lbs. per input unit  
 Consolidation cell pressure = 60.00 psi (8.64 ksf)  
 Consolidation back pressure = 20.00 psi (2.88 ksf)  
 Consolidation effective confining stress = 5.76 ksf  
 Strain rate, in./min. = 0.02  
 Fail. Stress = 4.61 ksf at reading no. 20

No.	Def. Dial in.	Load Dial	Load lbs.	Strain %	Deviator Stress ksf	Minor Eff. Stress ksf	Major Eff. Stress ksf	1:3 Ratio	Pore Press. psi	P ksf	Q ksf
0	0.0000	0.0	0.0	0.0	0.00	5.76	5.76	1.00	20.00	5.76	0.00
1	0.0100	104.0	74.9	0.2	1.80	5.13	6.92	1.35	24.40	6.03	0.90
2	0.0200	137.0	98.6	0.3	2.37	4.75	7.12	1.50	27.00	5.93	1.18
3	0.0300	155.0	111.6	0.5	2.67	4.45	7.12	1.60	29.10	5.79	1.34
4	0.0400	167.0	120.2	0.7	2.87	4.16	7.03	1.69	31.10	5.60	1.44
5	0.0500	178.0	128.2	0.8	3.06	3.92	6.97	1.78	32.80	5.45	1.53
6	0.0600	187.0	134.6	1.0	3.21	3.61	6.82	1.89	34.90	5.22	1.60
7	0.0700	196.0	141.1	1.2	3.35	3.37	6.72	2.00	36.60	5.05	1.68
8	0.0800	203.0	146.2	1.4	3.47	3.15	6.62	2.10	38.10	4.89	1.73
9	0.0900	208.0	149.8	1.5	3.55	2.97	6.51	2.20	39.40	4.74	1.77
10	0.1000	212.0	152.6	1.7	3.61	2.81	6.42	2.29	40.50	4.61	1.81
11	0.2000	236.0	169.9	3.4	3.95	1.70	5.65	3.32	48.20	3.67	1.97
12	0.3000	262.0	188.6	5.1	4.31	1.31	5.62	4.29	50.90	3.46	2.15
13	0.4000	273.0	196.6	6.8	4.41	1.22	5.63	4.60	51.50	3.43	2.20
14	0.5000	280.0	201.6	8.5	4.44	1.27	5.71	4.50	51.20	3.49	2.22
15	0.6000	293.0	211.0	10.2	4.56	1.27	5.83	4.60	51.20	3.55	2.28
16	0.7000	293.0	211.0	11.9	4.47	1.25	5.73	4.57	51.30	3.49	2.24
17	0.8000	304.0	218.9	13.6	4.55	1.27	5.82	4.59	51.20	3.54	2.28
18	0.9000	309.0	222.5	15.3	4.54	1.32	5.86	4.42	50.80	3.59	2.27
19	1.0000	314.0	226.1	17.0	4.52	1.34	5.86	4.37	50.70	3.60	2.26
20	1.1000	327.0	235.4	18.7	4.61	1.28	5.89	4.60	51.10	3.59	2.30
21	1.2000	325.0	234.0	20.4	4.48	1.22	5.71	4.66	51.50	3.47	2.24

**Parameters for Specimen No. 3**

Specimen Parameter	Initial	Saturated	Consolidated	Final
Moisture content: Moist soil+tare, gms.	1095.500			658.130
Moisture content: Dry soil+tare, gms.	839.200			494.670
Moisture content: Tare, gms.	0.000			13.340
Moisture, %	30.5	36.4	30.6	34.0
Moist specimen weight, gms.	1116.1			
Diameter, in.	2.82	2.82	2.74	
Area, in. <sup>2</sup>	6.23	6.23	5.90	
Height, in.	6.12	6.12	5.96	
Net decrease in height, in.		0.00	0.16	
Wet Density, pcf	111.4	116.4	121.0	
Dry density, pcf	85.3	85.3	92.7	
Void ratio	0.9897	0.9897	0.8327	
Saturation, %	83.9	100.0	100.0	

**Test Readings for Specimen No. 3**

Load ring constant = 0.72 lbs. per input unit  
 Consolidation cell pressure = 100.00 psi (14.40 ksf)  
 Consolidation back pressure = 20.00 psi (2.88 ksf)  
 Consolidation effective confining stress = 11.52 ksf  
 Strain rate, in./min. = 0.02  
 Fail. Stress = 12.35 ksf at reading no. 13

No.	Def. Dial in.	Load Dial	Load lbs.	Strain %	Deviator Stress ksf	Minor Eff. Stress ksf	Major Eff. Stress ksf	1:3 Ratio	Pore Press. psi	P ksf	Q ksf
0	0.0000	0.0	0.0	0.0	0.00	11.52	11.52	1.00	20.00	11.52	0.00
1	0.0100	71.0	51.1	0.2	1.25	11.35	12.59	1.11	21.20	11.97	0.62
2	0.0200	131.0	94.3	0.3	2.29	11.25	13.54	1.20	21.90	12.39	1.15
3	0.0300	262.0	188.6	0.5	4.58	10.92	15.50	1.42	24.20	13.21	2.29
4	0.0400	337.0	242.6	0.7	5.88	10.58	16.47	1.56	26.50	13.53	2.94
5	0.0500	399.0	287.3	0.8	6.95	10.25	17.21	1.68	28.80	13.73	3.48
6	0.0600	446.0	321.1	1.0	7.76	9.86	17.62	1.79	31.50	13.74	3.88
7	0.0700	487.0	350.6	1.2	8.46	9.52	17.98	1.89	33.90	13.75	4.23
8	0.0800	519.0	373.7	1.3	9.00	9.20	18.20	1.98	36.10	13.70	4.50
9	0.0900	549.0	395.3	1.5	9.50	8.88	18.39	2.07	38.30	13.64	4.75
10	0.1000	574.0	413.3	1.7	9.92	8.58	18.50	2.16	40.40	13.54	4.96
11	0.2000	706.0	508.3	3.4	11.99	6.68	18.67	2.79	53.60	12.68	6.00
12	0.3000	735.0	529.2	5.0	12.27	5.73	18.00	3.14	60.20	11.87	6.13
13	0.4000	753.0	542.2	6.7	12.35	5.24	17.59	3.36	63.60	11.42	6.17
14	0.5000	764.0	550.1	8.4	12.30	4.95	17.26	3.48	65.60	11.10	6.15
15	0.6000	758.0	545.8	10.1	11.98	4.78	16.76	3.51	66.80	10.77	5.99
16	0.7000	765.0	550.8	11.7	11.87	4.69	16.56	3.53	67.40	10.63	5.93
17	0.8000	752.0	541.4	13.4	11.44	4.69	16.14	3.44	67.40	10.42	5.72
18	0.9000	750.0	540.0	15.1	11.19	4.71	15.90	3.38	67.30	10.30	5.60
19	1.0000	752.0	541.4	16.8	11.00	4.74	15.74	3.32	67.10	10.24	5.50
20	1.1000	748.0	538.6	18.5	10.72	4.72	15.44	3.27	67.20	10.08	5.36
21	1.2000	760.0	547.2	20.1	10.67	4.74	15.41	3.25	67.10	10.07	5.33

# CONSOLIDATED UNDRAINED TRIAXIAL TEST

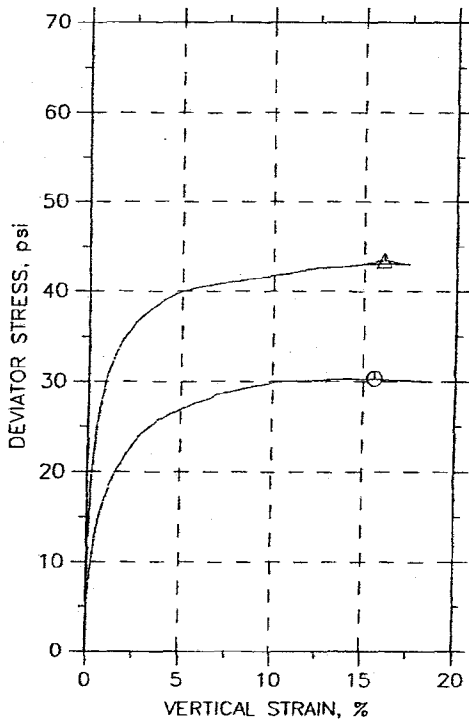
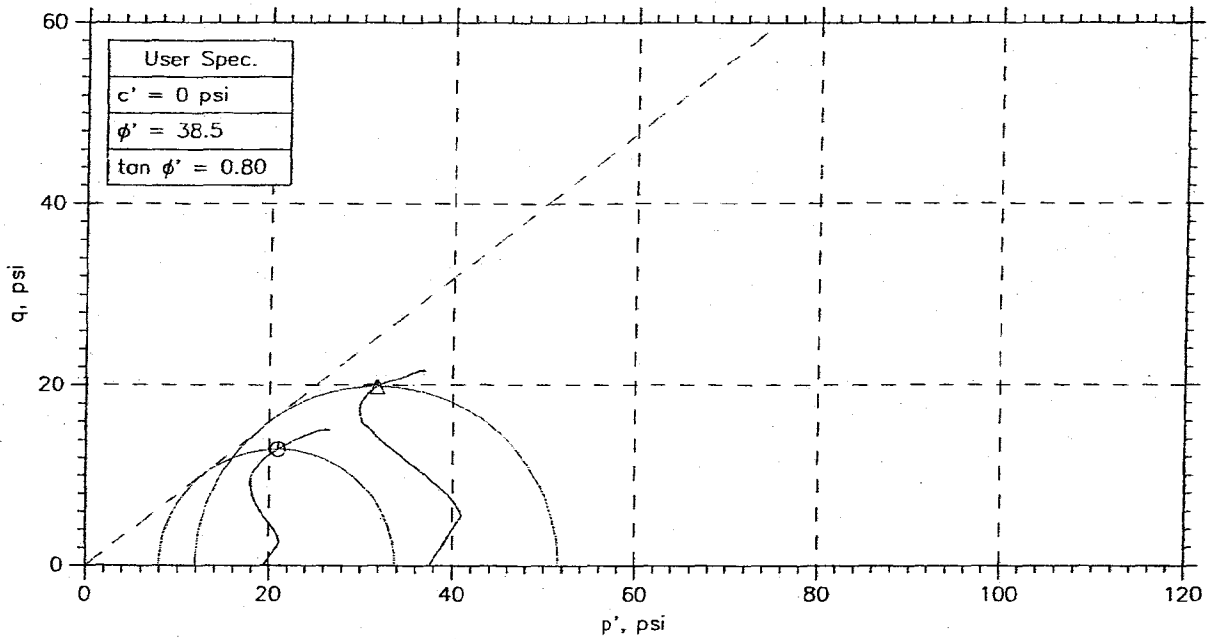

Symbol	○	△		
Sample No.	UD-1	UD-1		
Test No.	13774.1	13774.2		
Depth	20-22 Ft.	20-22 ft		
Initial	Diameter, in	2.84	2.821	
	Height, in	5.57	5.57	
	Water Content, %	43.8	40.8	
	Dry Density, pcf	77.03	79.62	
	Saturation, %	98.9	97.9	
Before Shear.	Void Ratio	1.21	1.14	
	Water Content, %	43.7	39.5	
	Dry Density, pcf	77.67	81.88	
	Saturation*, %	100.0	100.0	
	Void Ratio	1.19	1.08	
Back Press., psi	41.99	58		
Ver. Eff. Cons. Stress, psi	20	40		
Shear Strength, psi	15.17	21.71		
Strain at Failure, %	15.6	16.1		
Strain Rate, %/min	0.022	0.022		
B-Value	0.95	0.95		
Estimated Specific Gravity	2.72	2.72		
Liquid Limit	79	79		
Plastic Limit	40	40		

<b>GeoTesting</b> Express <small>the groundwork for success</small>	Project: TVA Kingston Gypsym Stack				
	Location: NB-47ba				
	Project No.: GTX G0959				
	Boring No.: NB-47BA				
	Sample Type: Shelby Tube				
Description:					
Remarks:					

Phase calculations based on start and end of test.

\* Saturation is set to 100% for phase calculations.

# CONSOLIDATED UNDRAINED TRIAXIAL TEST

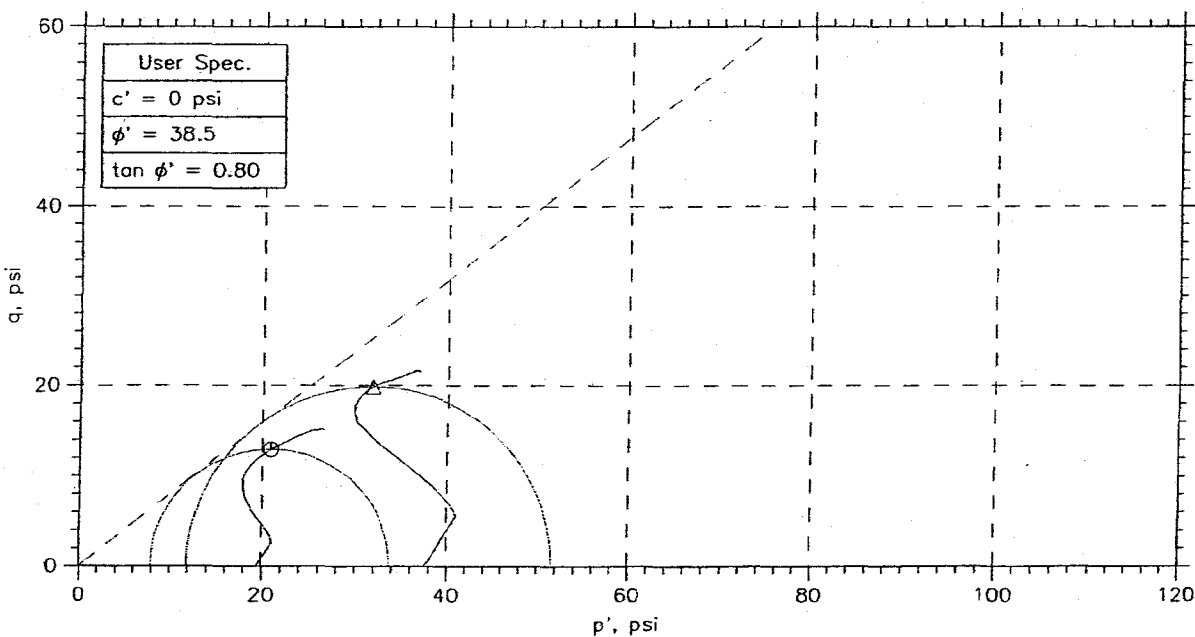
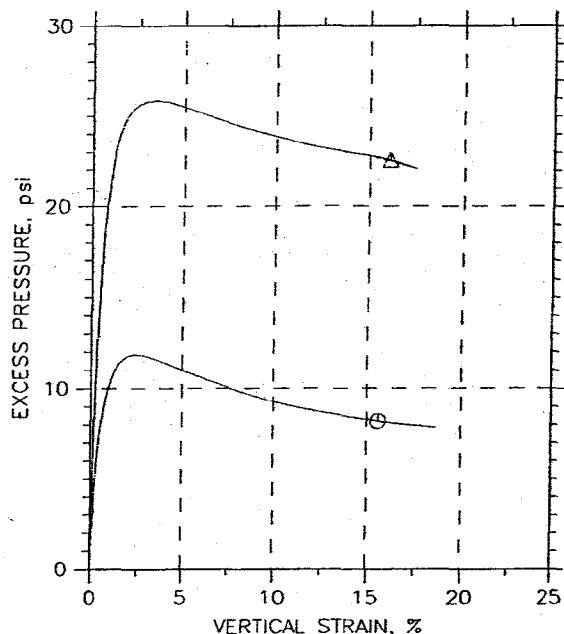
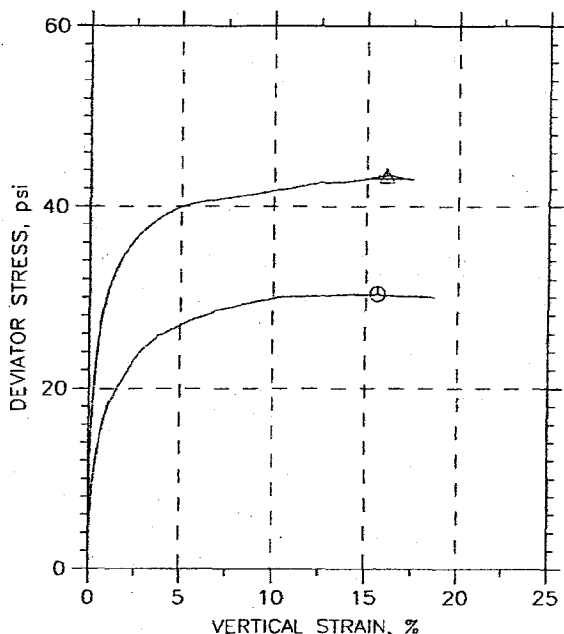

	Sample No.	Test No.	Depth	Tested By	Test Date	Checked By	Check Date	Test File
○	UD-1	13774.1	20-22 Ft.	JW	12/17/05	HJ		13774.1a_2054.dot
△	UD-1	13774.2	20-22 ft	JW	12/17/05	HJ		13774.2a_1057.dot

**GeoTesting**  
express  
the groundwork for success

Project: TVA Kingston Gypsum Sill	Location: NB-47ba	Project No.: GTX G0959
Boring No.: NB-47BA	Sample Type: Shelby Tube	
Description:		
Remarks:		



## CONSOLIDATED UNDRAINED TRIAXIAL TEST

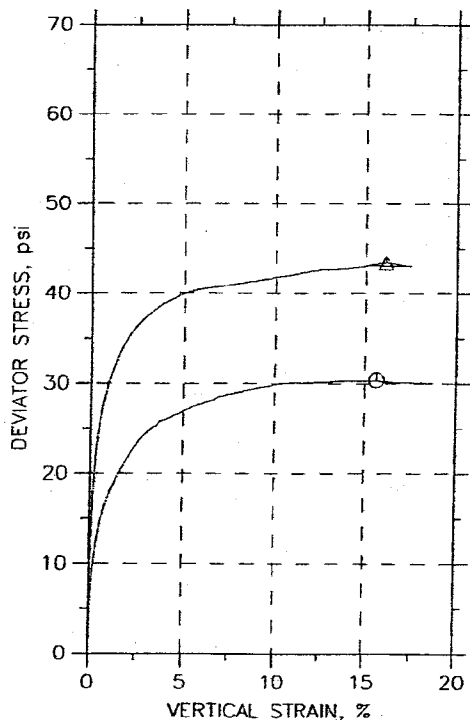
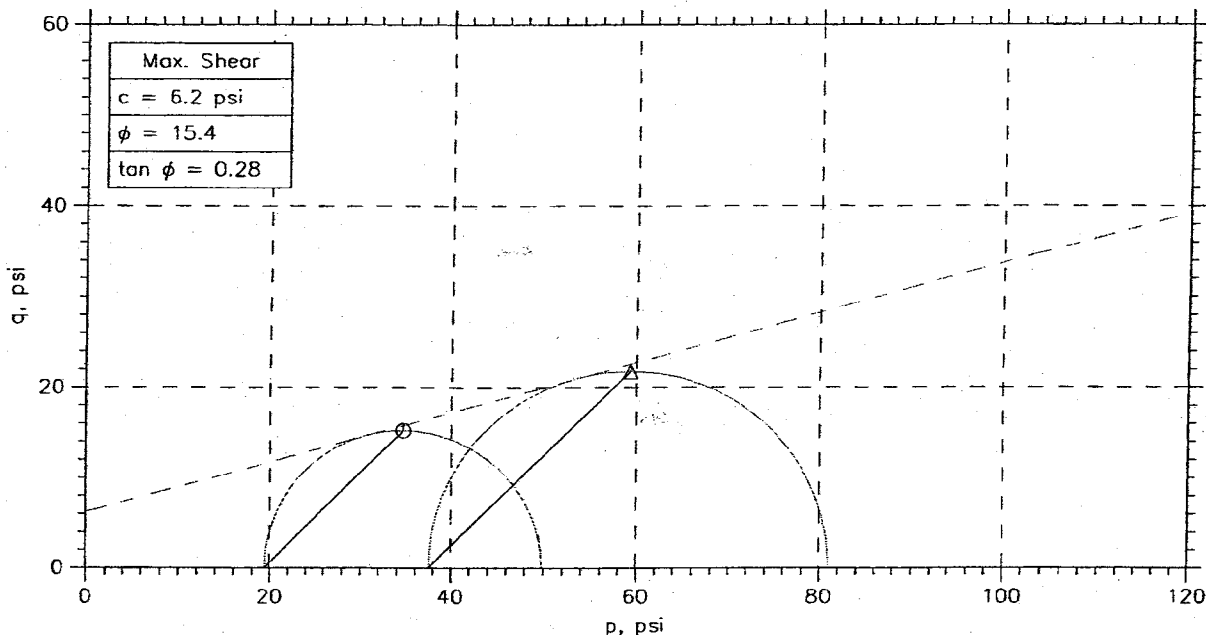

Symbol	⊙	Δ		
Sample No.	UD-1	UD-1		
Test No.	13774.1	13774.2		
Depth	20-22 Ft.	20-22 ft		
Initial	Diameter, in	2.84	2.821	
	Height, in	5.57	5.57	
	Water Content, %	43.8	40.8	
	Dry Density, pcf	77.03	79.62	
	Saturation, %	98.9	97.9	
Before Shear	Void Ratio	1.21	1.14	
	Water Content, %	43.7	39.5	
	Dry Density, pcf	77.67	81.88	
	Saturation*, %	100.0	100.0	
	Void Ratio	1.19	1.08	
	Back Press., psi	41.99	58	
	Ver. Eff. Cons. Stress, psi	20	40	
	Shear Strength, psi	15.17	21.71	
	Strain at Failure, %	15.6	16.1	
	Strain Rate, %/min	0.022	0.022	
	B-Value	0.95	0.95	
	Estimated Specific Gravity	2.72	2.72	
	Liquid Limit	79	79	
	Plastic Limit	40	40	

**GeoTesting**  
express  
the groundwork for success

Project: TVA Kingston Gypsum Stack

Location: NB-47ba

Project No.: GTX G0959

Boring No.: NB-47BA

Sample Type: Shelby Tube

Description:

Remarks:

Phase calculations based on start and end of test.

\* Saturation is set to 100% for phase calculations.

Thu, 02-FEB-2006 15:07:49

TVA-00021799

# CONSOLIDATED UNDRAINED TRIAXIAL TEST

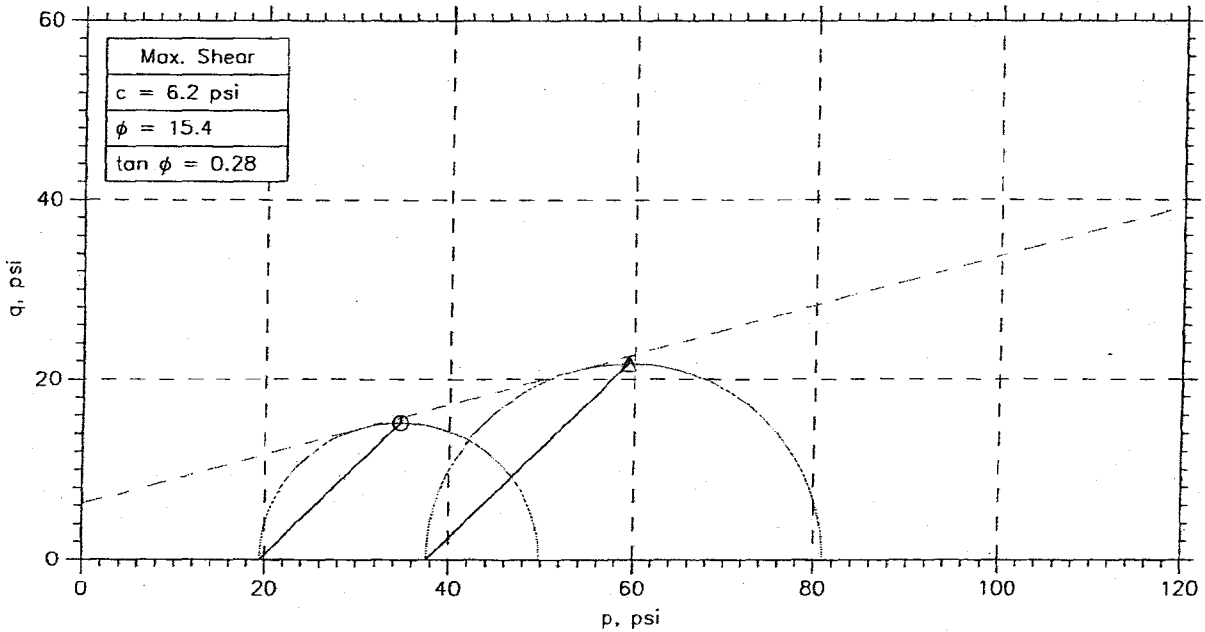
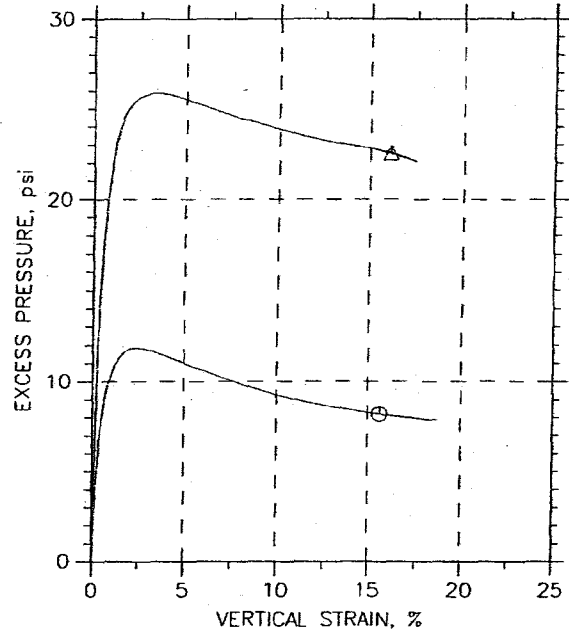
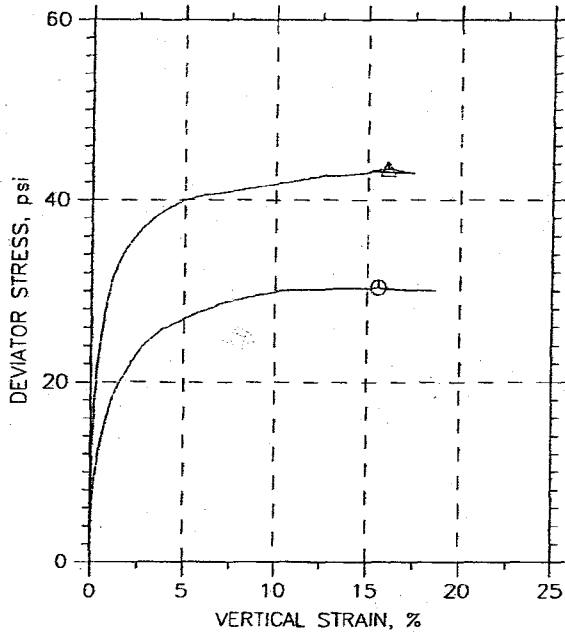

	Sample No.	Test No.	Depth	Tested By	Test Date	Checked By	Check Date	Test File
⊙	UD-1	13774.1	20-22 Ft.	JW	12/17/05	HJ		13774.1a_2054.dot
△	UD-1	13774.2	20-22 ft	JW	12/17/05	HJ		13774.2a_1057.dot

<b>Geotesting</b> <b>Express</b> <small>the groundwork for success</small>	Project: TVA Kingston Gypsum Station		Location: NB-47ba		Project No.: GTX G0959	
	Boring No.: NB-47BA		Sample Type: Shelby Tube			
	Description:					
	Remarks:					

## CONSOLIDATED UNDRAINED TRIAXIAL TEST

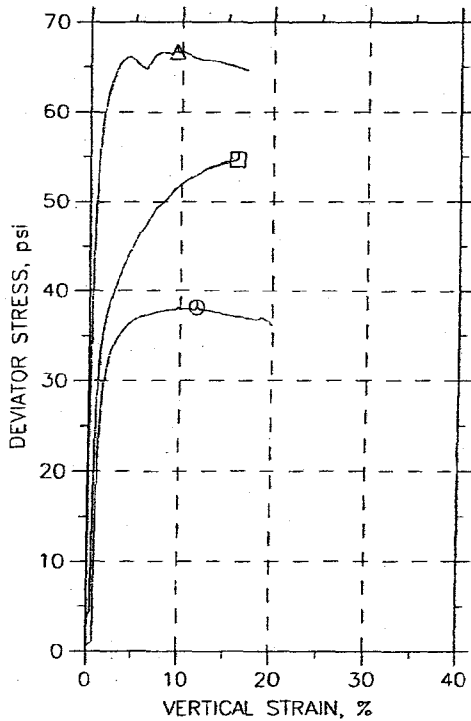
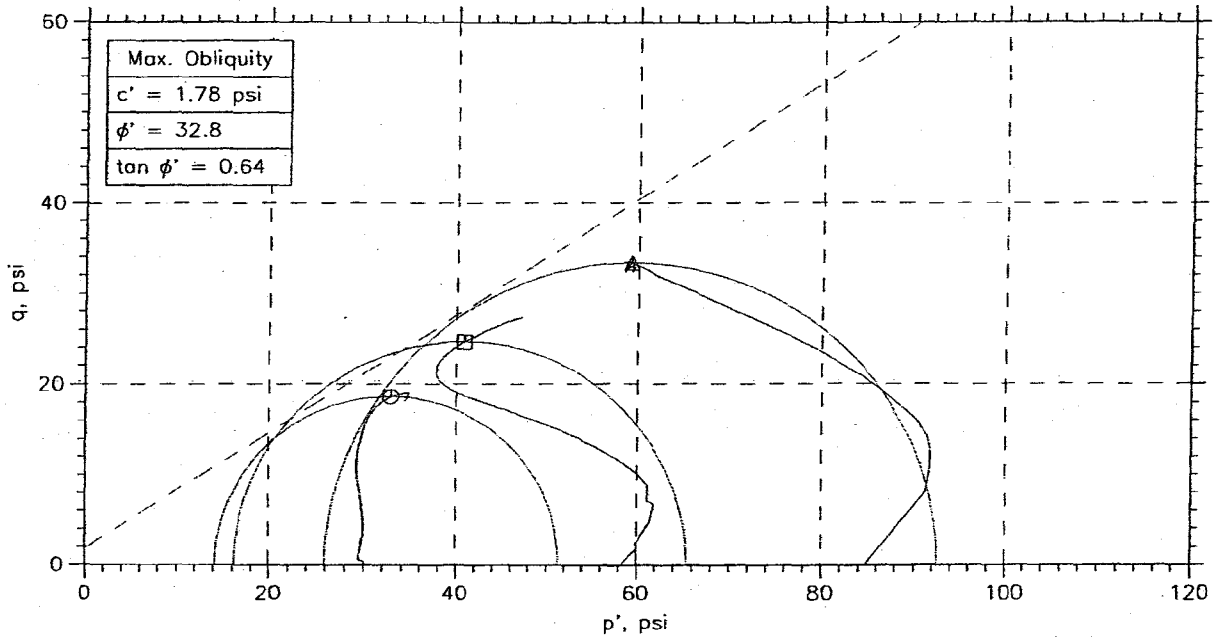

Symbol	⊙	△	□	
Sample No.	UD-3	UD-3	UD-1	
Test No.	13767.4	13767.3	13768.1	
Depth	40-42 Ft.	40-42 ft	40-42 ft	
Initial	Diameter, in	2.846	2.83	2.848
	Height, in	5.57	5.57	5.57
	Water Content, %	26.2	26.2	29.6
	Dry Density, pcf	98.67	100.1	95.95
	Saturation, %	97.9	101.0	103.4
Before Shear	Void Ratio	0.735	0.71	0.785
	Water Content, %	24.5	21.8	23.3
	Dry Density, pcf	102.4	107.2	104.4
	Saturation*, %	100.0	100.0	100.0
	Void Ratio	0.672	0.597	0.64
	Back Press., psi	61.99	54	58
	Ver. Eff. Cons. Stress, psi	30	89.99	60
	Shear Strength, psi	19.08	33.35	27.32
	Strain at Failure, %	11.8	9.46	16.1
	Strain Rate, %/min	0.022	0.022	0.022
	B-Value	0.95	0.95	0.95
	Measured Specific Gravity	2.74	2.74	2.74
	Liquid Limit	51	51	54
	Plastic Limit	24	24	24

<b>GeoTesting</b> express <i>the groundwork for success</i>	Project: TVA Kingston Gypsum Stack				
	Location: NB-73				
	Project No.: GTX G0959				
	Boring No.: NB-73WB				
	Sample Type: Shelby Tube				
	Description:				
Remarks:					

Phase calculations based on start and end of test.

\* Saturation is set to 100% for phase calculations.

# CONSOLIDATED UNDRAINED TRIAXIAL TEST

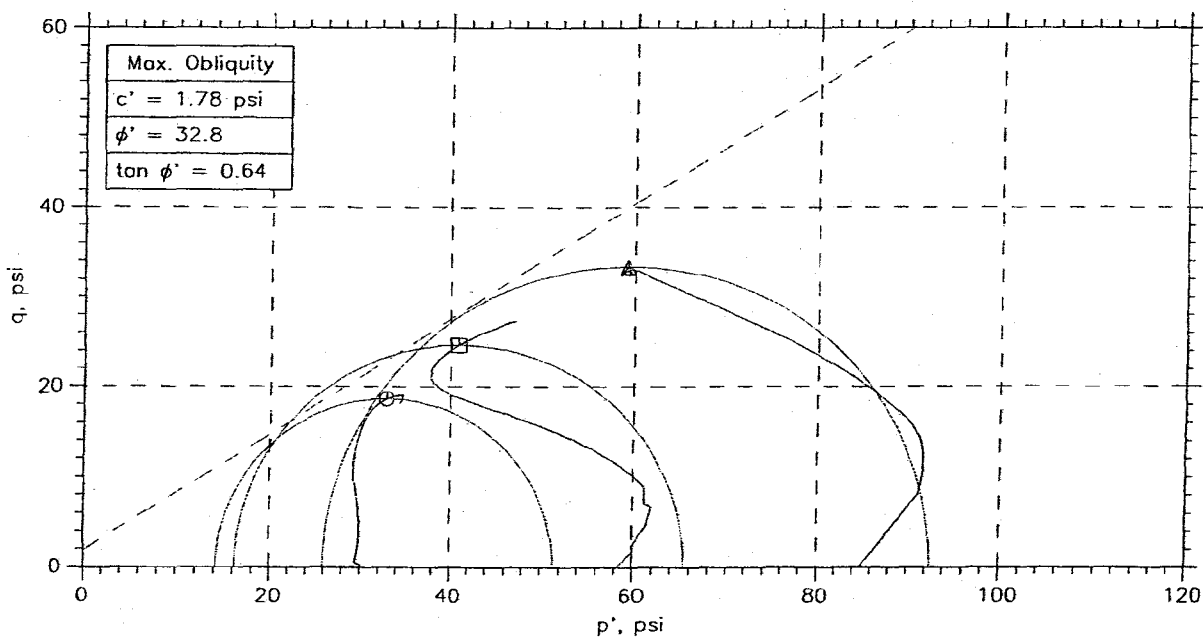
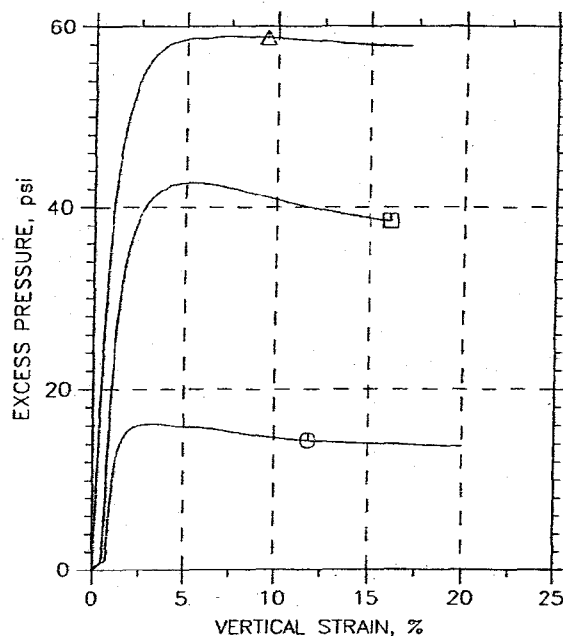
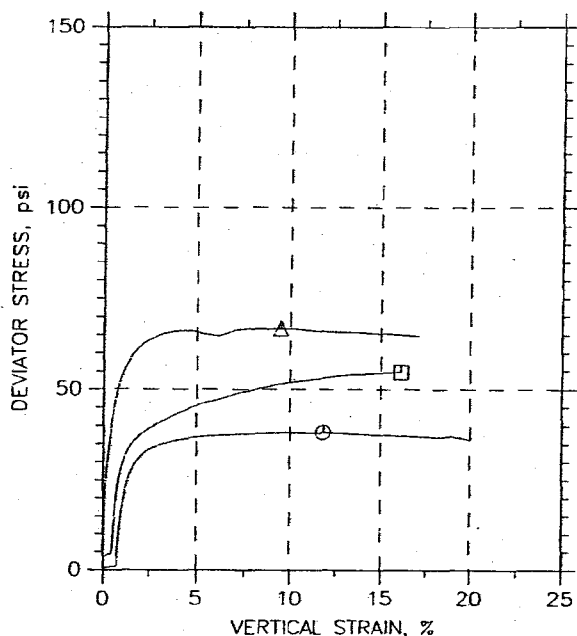

Symbol	Sample No.	Test No.	Depth	Tested By	Test Date	Checked By	Check Date	Test File
○	UD-3	13767.4	40-42 Ft.	HJ	12/6/05	JW		13767.4_2054.dat
△	UD-3	13767.3	40-42 ft	JW	12/3/05	HJ		13767.3_1062.dat
□	UD-1	13768.1	40-42 ft	JW	12/7/05	HJ		13768.1_1062.dat

**GeoTesting**  
Express  
the groundwork for success

Project: TVA Kingston Gypsum Storage Location: NB-73	Project No.: GTX G0959
Boring No.: NB-73WB	Sample Type: Shelby Tube
Description:	
Remarks:	

# CONSOLIDATED UNDRAINED TRIAXIAL TEST

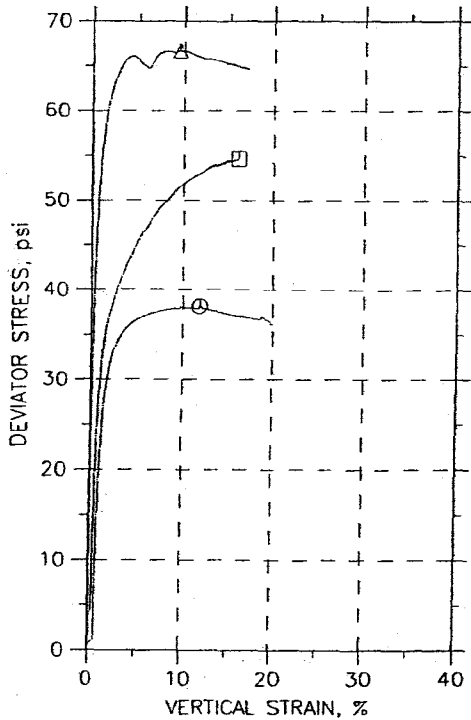
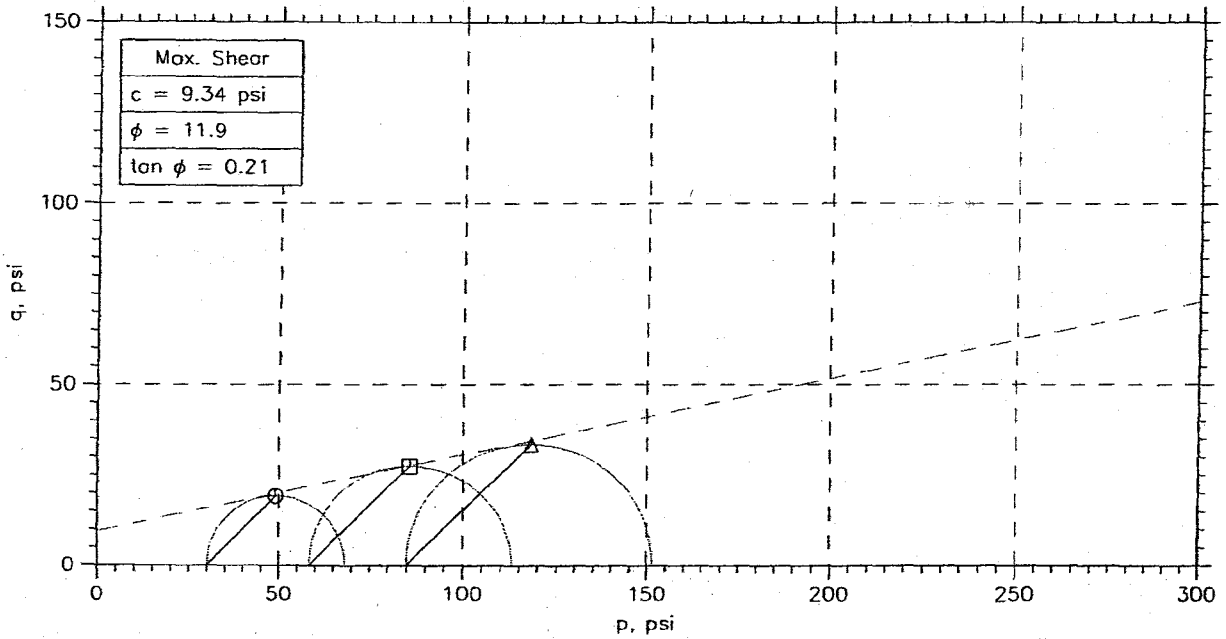

Symbol	⊙	△	⊠	
Sample No.	UD-3	UD-3	UD-1	
Test No.	13767.4	13767.3	13768.1	
Depth	40-42 Ft.	40-42 ft	40-42 ft	
Initial	Diameter, in	2.846	2.83	2.848
	Height, in	5.57	5.57	5.57
	Water Content, %	26.2	26.2	29.6
	Dry Density, pcf	98.67	100.1	95.95
	Saturation, %	97.9	101.0	103.4
Before Shear	Void Ratio	0.735	0.71	0.785
	Water Content, %	24.5	21.8	23.3
	Dry Density, pcf	102.4	107.2	104.4
	Saturations, %	100.0	100.0	100.0
Void Ratio	0.672	0.597	0.64	
Back Press., psi	61.99	54	58	
Ver. Eff. Cons. Stress, psi	30	89.99	60	
Shear Strength, psi	19.08	33.35	27.32	
Strain at Failure, %	11.8	9.46	16.1	
Strain Rate, %/min	0.022	0.022	0.022	
B-Value	0.95	0.95	0.95	
Measured Specific Gravity	2.74	2.74	2.74	
Liquid Limit	51	51	54	
Plastic Limit	24	24	24	

<b>Geotesting</b> express <i>the groundwork for success</i>	Project: TVA Kingston Gypsum Stack				
	Location: NB-73				
	Project No.: GTX G0959				
	Boring No.: NB-73 <b>WB</b>				
	Sample Type: Shelby Tube				
	Description:				
Remarks:					

Phase calculations based on start and end of test.

\* Saturation is set to 100% for phase calculations.

# CONSOLIDATED UNDRAINED TRIAXIAL TEST

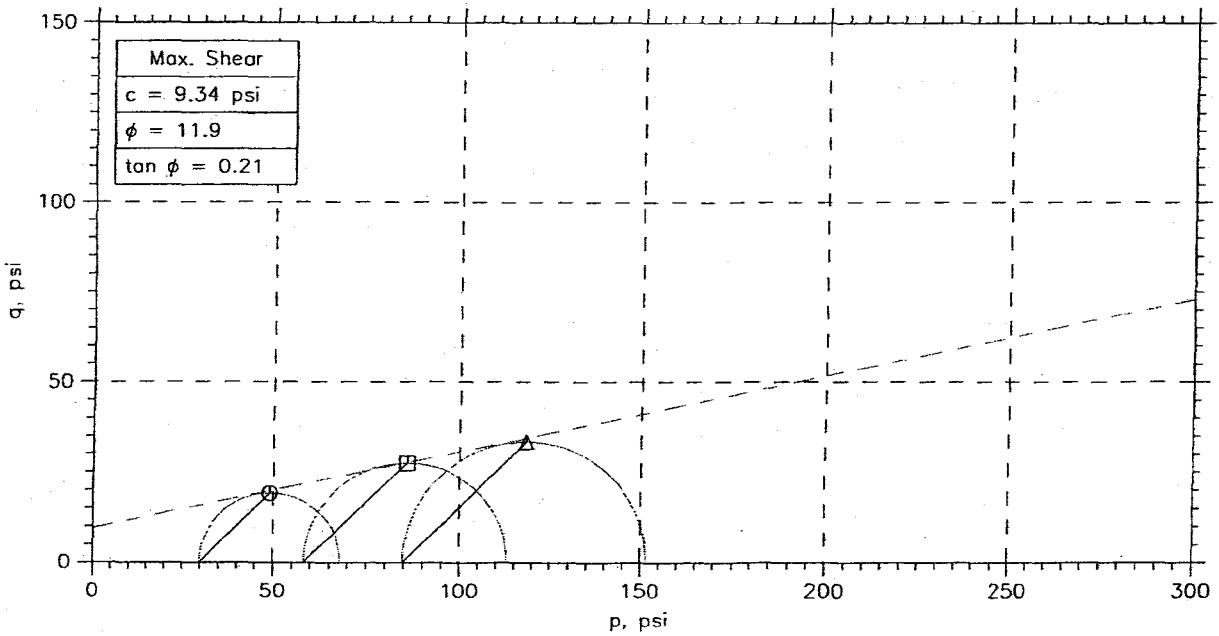
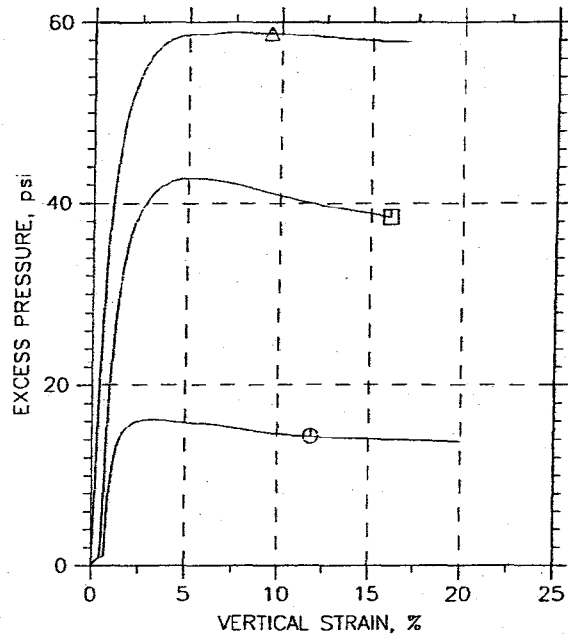
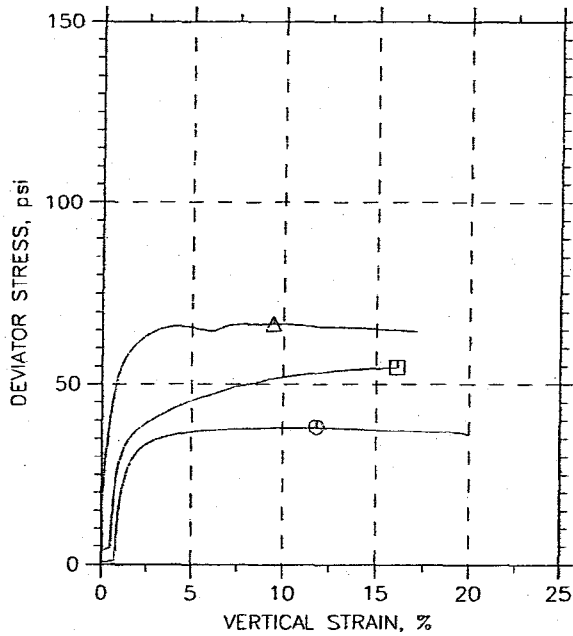

Symbol	Sample No.	Test No.	Depth	Tested By	Test Date	Checked By	Check Date	Test File
○	UD-3	13767.4	40-42 Ft.	HJ	12/6/05	JW		13767.4_2054.dat
△	UD-3	13767.3	40-42 ft	JW	12/3/05	HJ		13767.3_1062.dat
□	UD-1	13768.1	40-42 ft	JW	12/7/05	HJ		13768.1_1062.dat

<b>GeoTesting</b> <b>express</b> <small>the groundwork for success</small>	Project: TVA Kingston Gypsum Storage Location: NB-73		Project No.: GTX G0959
	Boring No.: NB-73WB		Sample Type: Shelby Tube
	Description:		
	Remarks:		

# CONSOLIDATED UNDRAINED TRIAXIAL TEST

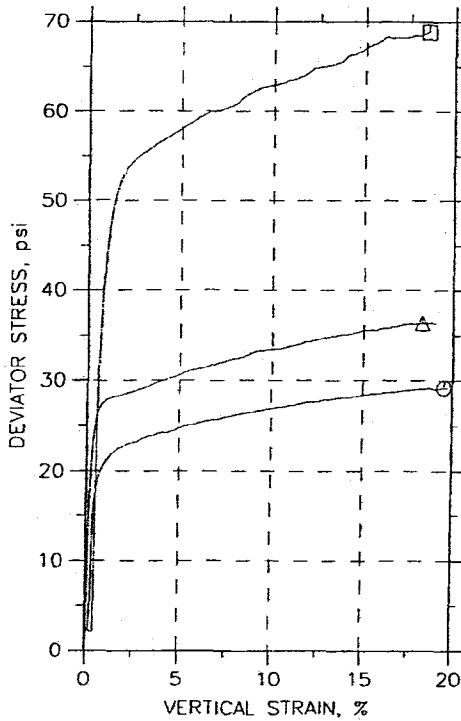
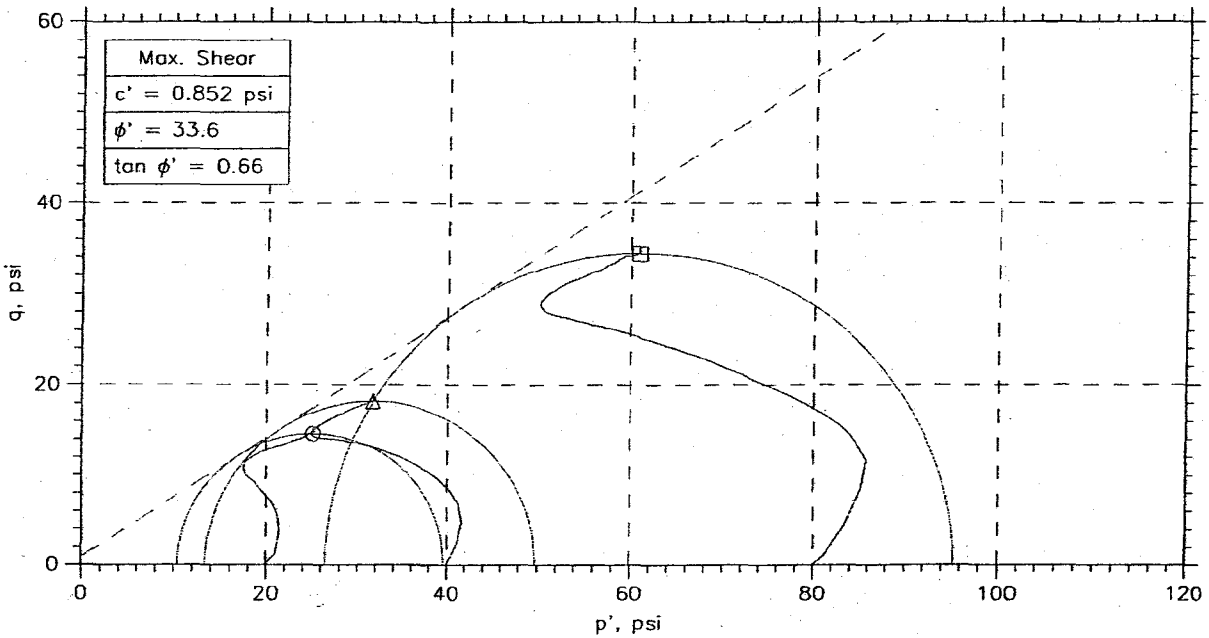

Symbol	⊙	△	□	
Sample No.	Bag	Bag	Bag	
Test No.	13925.1	13925.2	13925.3	
Depth	5-15 ft	5-15 ft	5-15 ft	
Initial	Diameter, in	2.87	2.87	2.87
	Height, in	6	6	6
	Water Content, %	23.1	22.7	23.2
	Dry Density, pcf	95.94	95.96	95.56
	Saturation, %	84.6	83.1	84.2
	Void Ratio	0.724	0.724	0.731
Before Shear	Water Content, %	25.9	25.4	23.3
	Dry Density, pcf	98.12	98.9	102.2
	Saturation*, %	100.0	100.0	100.0
	Void Ratio	0.686	0.673	0.618
Back Press., psi	89.98	90	60.01	
Ver. Eff. Cons. Stress, psi	20.01	40	79.98	
Shear Strength, psi	14.59	18.18	34.4	
Strain at Failure, %	19.5	18.3	18.5	
Strain Rate, %/min	0.022	0.022	0.022	
B-Value	0.95	0.95	0.95	
Measured Specific Gravity	2.65	2.65	2.65	
Liquid Limit	48	48	48	
Plastic Limit	28	28	28	

<b>Geotesting</b> express <i>the groundwork for success</i>	Project: TVA Kingston Gypsum Stack				
	Location: NB-76				
	Project No.: GTX G0959				
	Boring No.: NB-76				
	Sample Type: Remolded				
	Description: Reddish Brown Sandy Silt				
Remarks: Remolded to 95% of Standard Proctor max. dry density and +2% opt.					

Phase calculations based on start of test.  
 \* Saturation is set to 100% for phase calculations.

# CONSOLIDATED UNDRAINED TRIAXIAL TEST

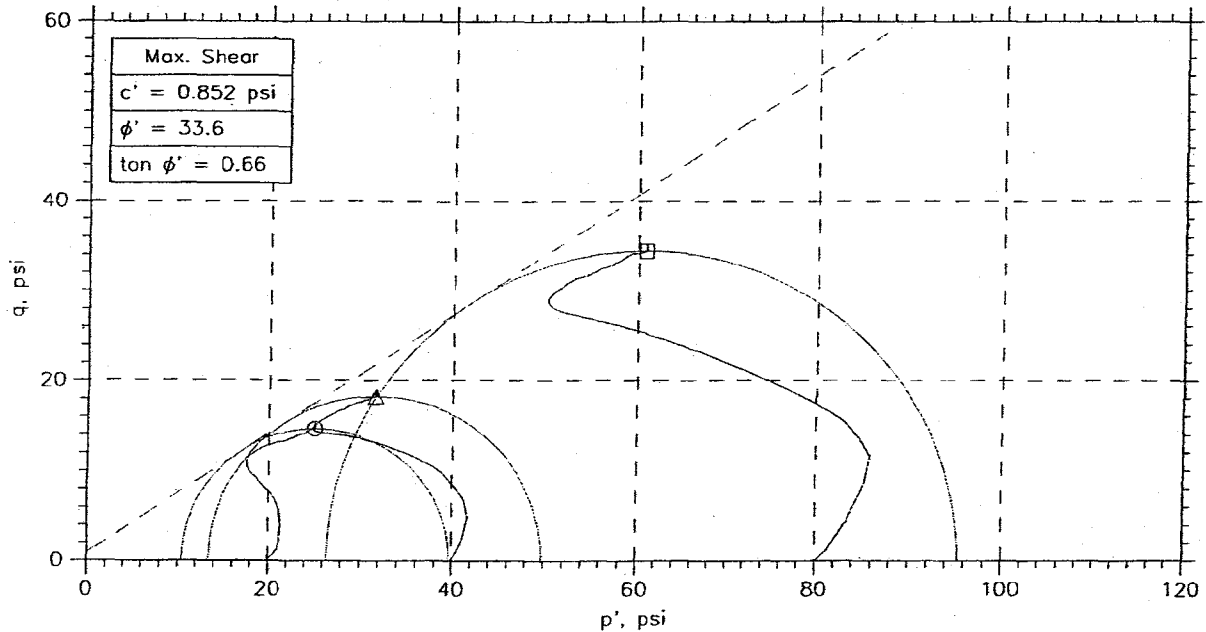
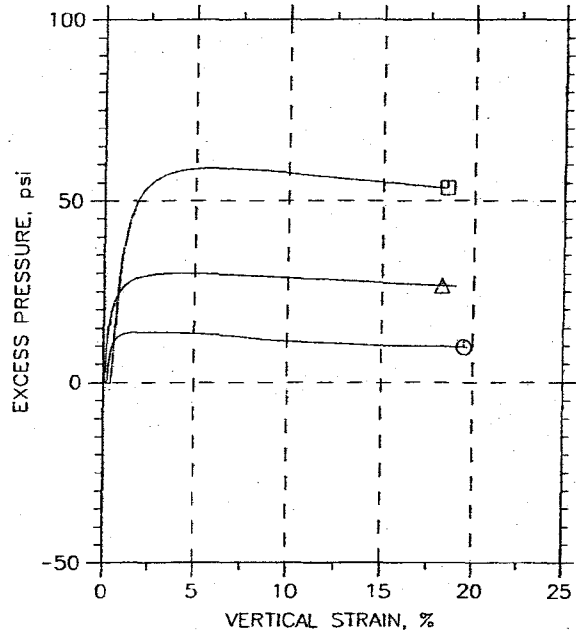
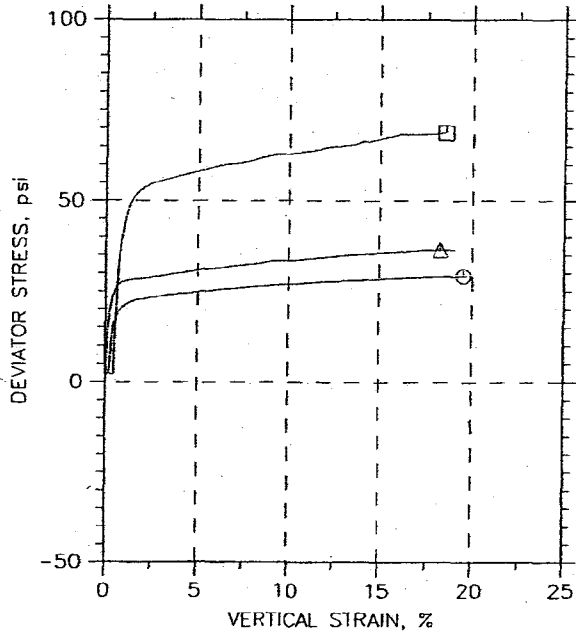

	Sample No.	Test No.	Depth	Tested By	Test Date	Checked By	Check Date	Test File
○	Bag	13925.1	5-15 ft	HJ	1/21/06	JW		13925.1a_2054.dat
△	Bag	13925.2	5-15 ft	JW	1/21/06	HJ		13925.2a_1062.dat
□	Bag	13925.3	5-15 ft	JW	1/19/05	HJ		13925.3a_1057.dat

**GeoTesting**  
**express**  
the groundwork for success

Project: TVA Kingston Gypsum Storage	Location: NB-76	Project No.: GTX G0959
Boring No.: NB-76	Sample Type: Remolded	
Description: Reddish Brown Sandy Silt		
Remarks: Remolded to 95% of Standard Proctor max. dry density and +2% opt.		



## CONSOLIDATED UNDRAINED TRIAXIAL TEST

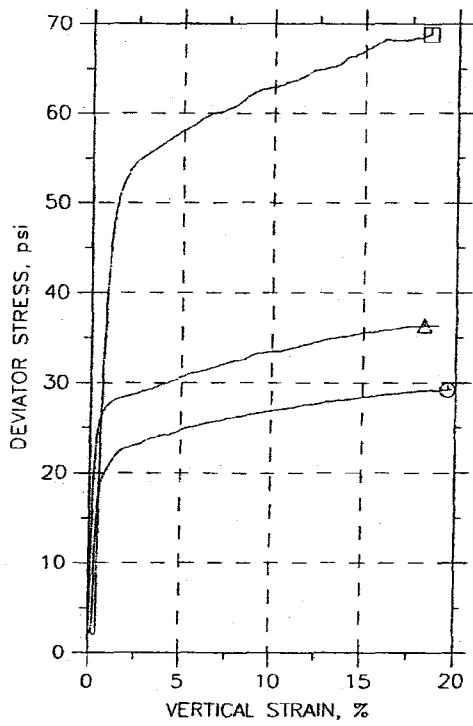
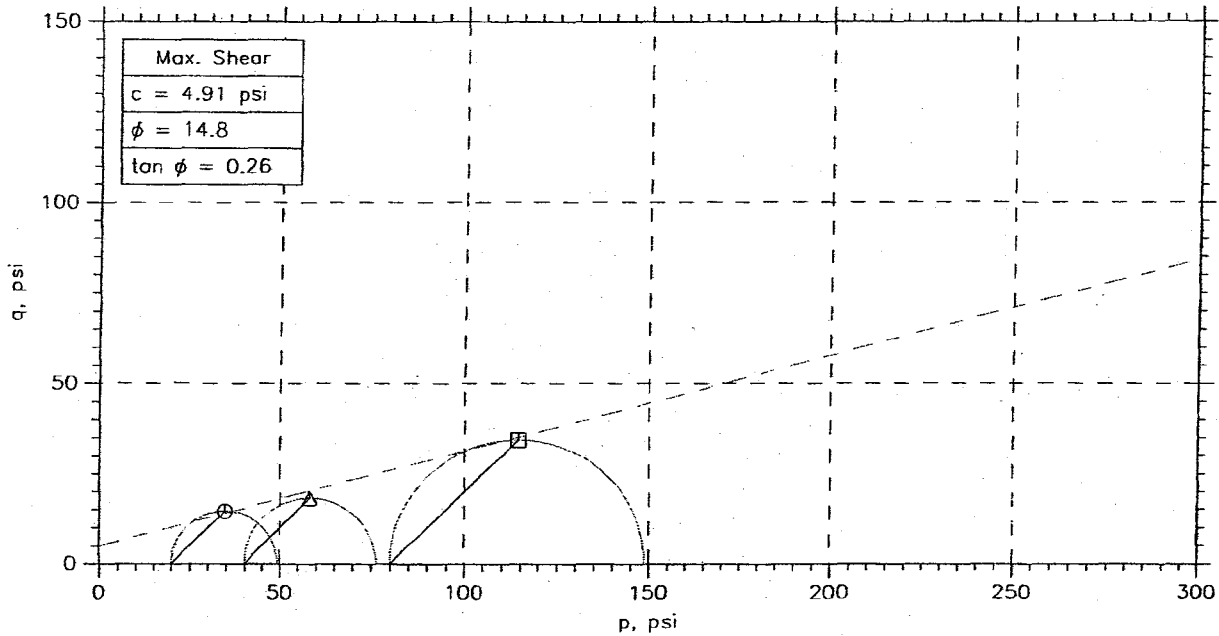

Symbol	⊙	△	⊠	
Sample No.	Bag	Bag	Bag	
Test No.	13925.1	13925.2	13925.3	
Depth	5-15 ft	5-15 ft	5-15 ft	
Initial	Diameter, in	2.87	2.87	2.87
	Height, in	6	6	6
	Water Content, %	23.1	22.7	23.2
	Dry Density, pcf	95.94	95.96	95.56
	Saturation, %	84.6	83.1	84.2
Before Shear	Void Ratio	0.724	0.724	0.731
	Water Content, %	25.9	25.4	23.3
	Dry Density, pcf	98.12	98.9	102.2
	Saturation*, %	100.0	100.0	100.0
	Void Ratio	0.686	0.673	0.618
Back Press., psi	89.98	90	60.01	
Ver. Eff. Cons. Stress, psi	20.01	40	79.98	
Shear Strength, psi	14.59	18.18	34.4	
Strain at Failure, %	19.5	18.3	18.5	
Strain Rate, %/min	0.022	0.022	0.022	
B-Value	0.95	0.95	0.95	
Measured Specific Gravity	2.65	2.65	2.65	
Liquid Limit	48	48	48	
Plastic Limit	28	28	28	

**GeoTesting**  
**xpress**  
ground-work for success

Project: TVA Kingston Gypsum Stack				
Location: NB-76				
Project No.: GTX G0959				
Boring No.: NB-76				
Sample Type: Remolded				
Description: Reddish Brown Sandy Silt				
Remarks: Remolded to 95% of Standard Proctor max. dry density and +2% opt.				

Phase calculations based on start of test.  
 \* Saturation is set to 100% for phase calculations.

## CONSOLIDATED UNDRAINED TRIAXIAL TEST

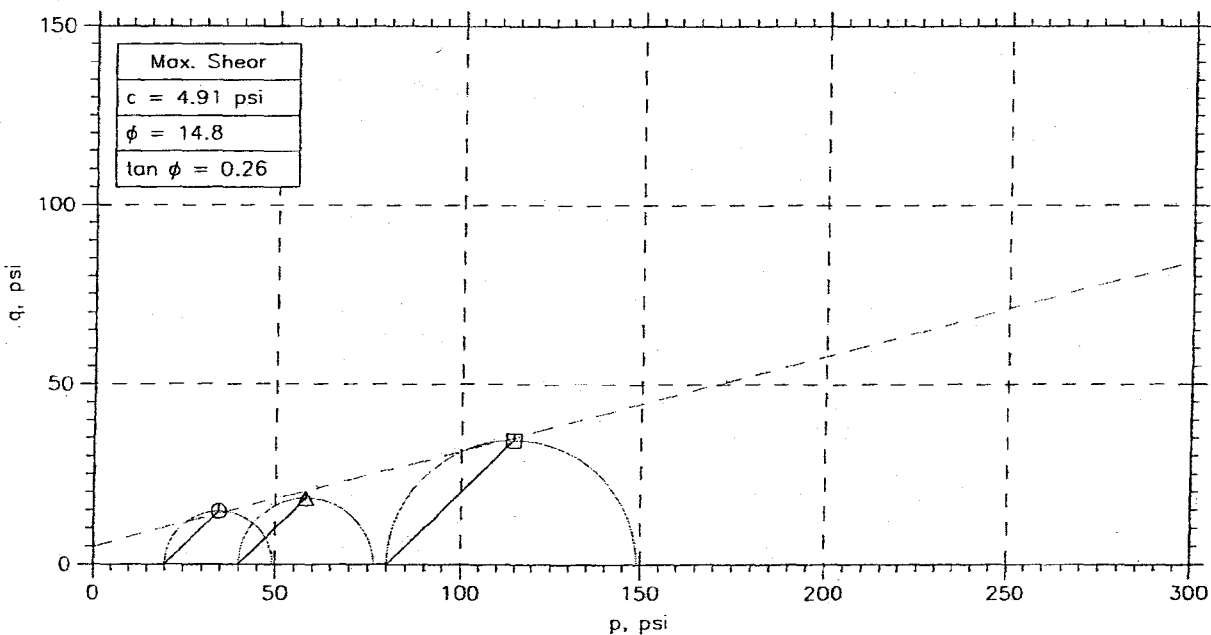
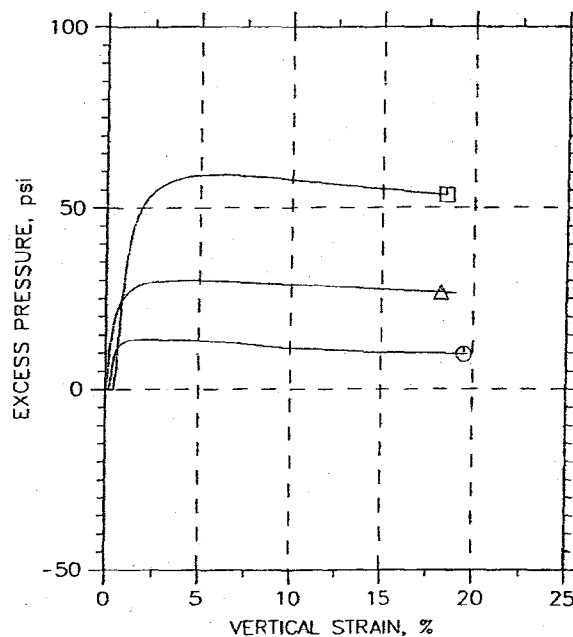
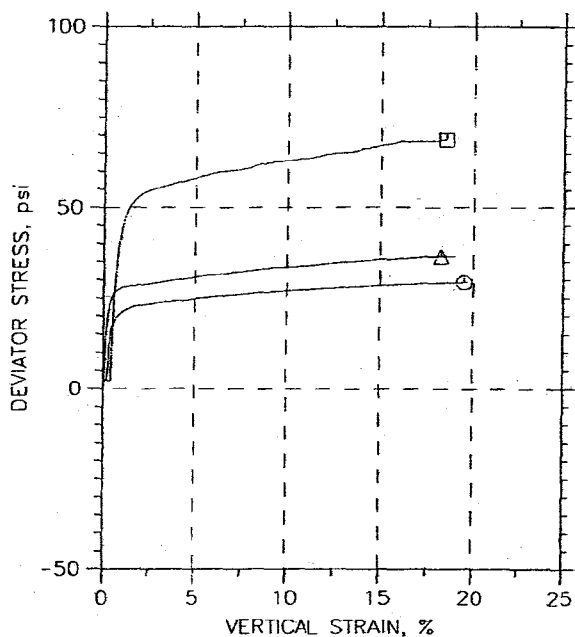

Symbol	Sample No.	Test No.	Depth	Tested By	Test Date	Checked By	Check Date	Test File
○	Bag	13925.1	5-15 ft	HJ	1/21/06	JW		13925.1a_2054.dat
△	Bag	13925.2	5-15 ft	JW	1/21/06	HJ		13925.2a_1062.dat
□	Bag	13925.3	5-15 ft	JW	1/19/05	HJ		13925.3a_1057.dat

**GeoTesting**  
express  
the groundwork for success

Project: TVA Kingston Gypsum Storage	Location: NB-76	Project No.: GTX G0959
Boring No.: NB-76	Sample Type: Remolded	
Description: Reddish Brown Sandy Silt		
Remarks: Remolded to 95% of Standard Proctor max. dry density and +2% opt.		

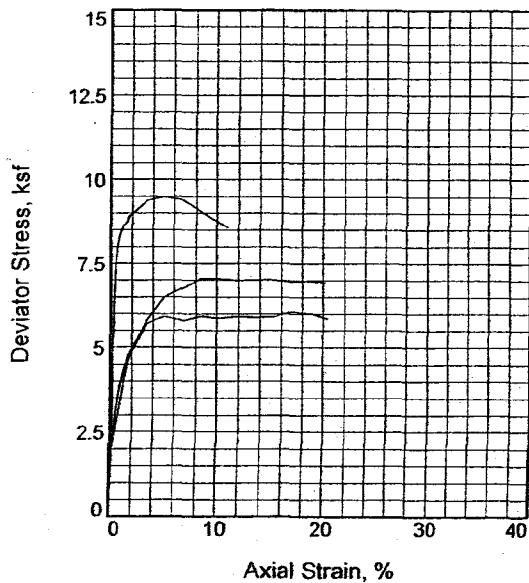
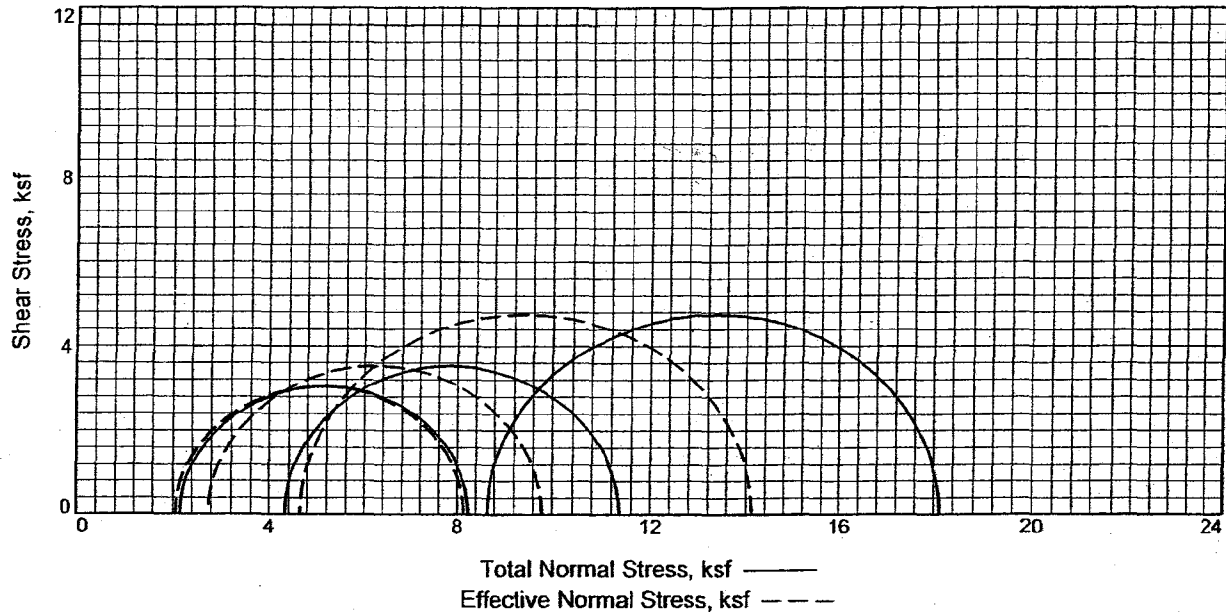

Sample No.		1	2	3
Initial	Water Content,	24.6	19.0	30.2
	Dry Density, pcf	99.2	105.0	87.2
	Saturation,	97.4	87.0	88.8
	Void Ratio	0.6732	0.5815	0.9051
	Diameter, in.	2.84	2.86	2.82
	Height, in.	6.03	6.10	6.07
At Test	Water Content,	20.2	17.4	28.7
	Dry Density, pcf	108.0	113.6	94.2
	Saturation,	100.0	100.0	100.0
	Void Ratio	0.5375	0.4622	0.7625
	Diameter, in.	2.76	2.78	2.74
	Height, in.	5.86	5.94	5.92
Strain rate, in./min.		0.02	0.02	0.02
Back Pressure, ksf		5.8	5.8	5.8
Cell Pressure, ksf		7.9	10.1	14.4
Fail. Stress, ksf		6.1	7.0	9.5
Total Pore Pr., ksf		5.9	7.3	9.7
Ult. Stress, ksf				
Total Pore Pr., ksf				
$\bar{\sigma}_1$ Failure, ksf		8.1	9.8	14.1
$\bar{\sigma}_3$ Failure, ksf		2.1	2.7	4.7

**Type of Test:**

CU with Pore Pressures

**Sample Type:** undisturbed

**Description:** Brownish yellow sandy lean clay

LL= 41

PL= 25

PI= 16

**Specific Gravity:** 2.66

**Remarks:** CL

**Client:** TVA

**Project:** TVA Kingston - Proposed Gypsum Stack

**Location:** NB-77A

**Sample Number:** UD-1, 2 & 3 (CU)

**Depth:** 4'-14'

**Proj. No.:** 3043051021

**Date:**

TRIAXIAL SHEAR TEST REPORT

**MACTEC, INC.**

Figure \_\_\_\_\_

Tested By: Alexander \_\_\_\_\_

Checked By: Hamlett \_\_\_\_\_

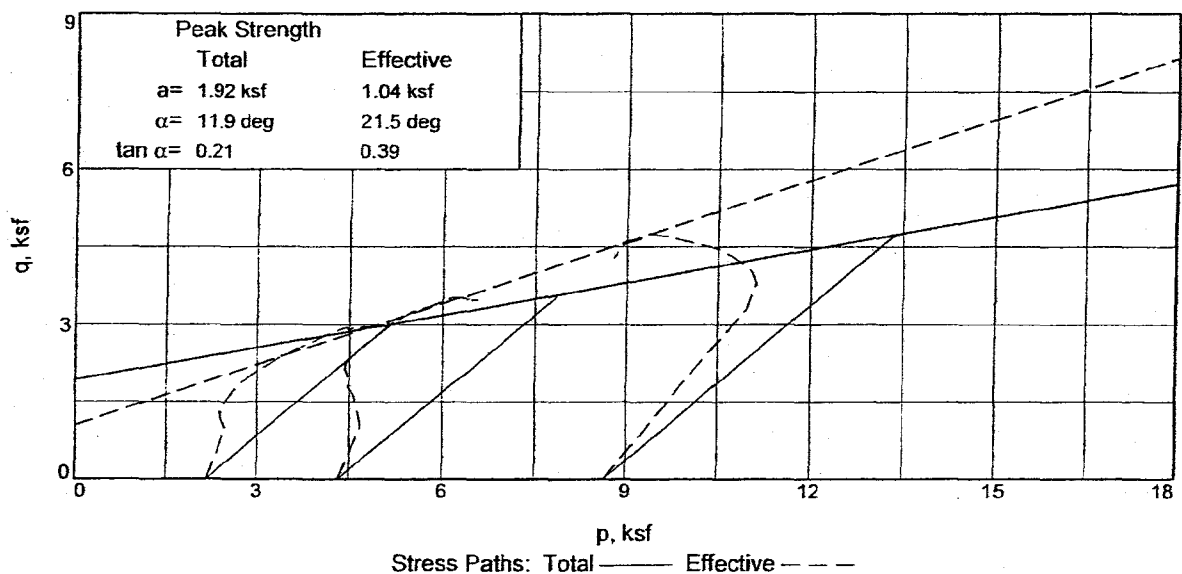
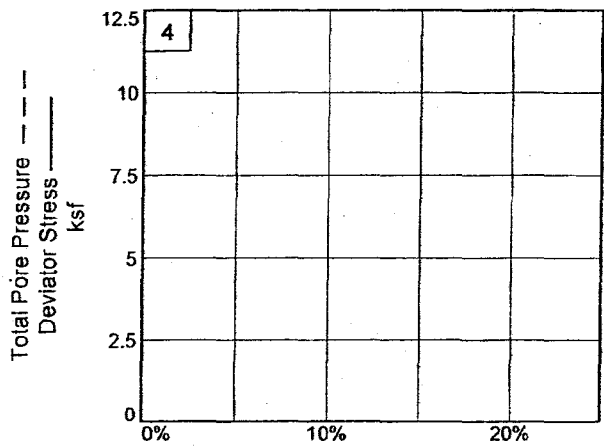
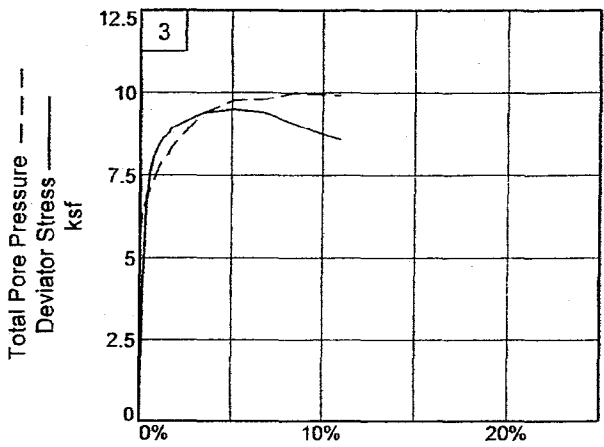
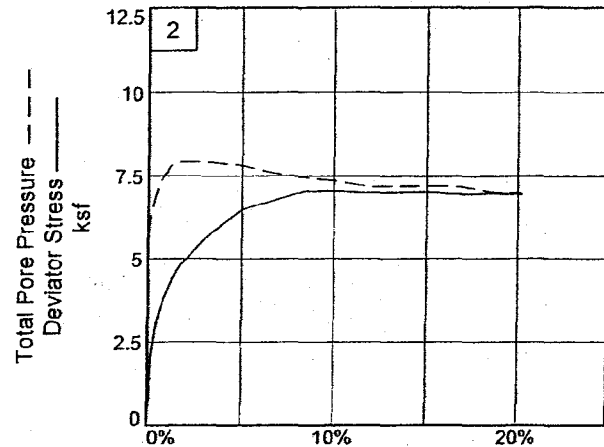
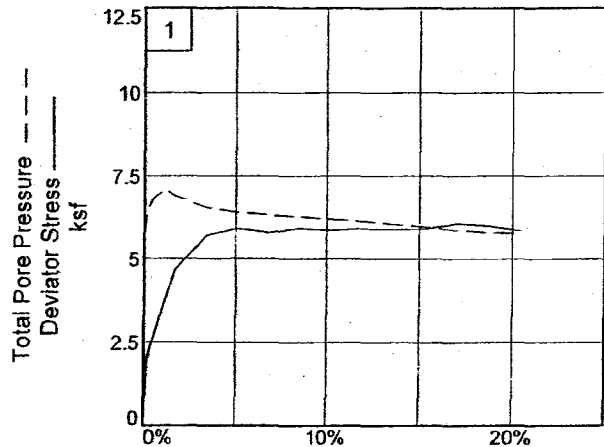

Client: TVA

Project: TVA Kingston - Proposed Gypsum Stack

Location: NB-77A

Depth: 4'-14'

Sample Number: UD-1, 2 & 3 (CU)

Project No.: 3043051021

Figure \_\_\_\_\_

**MACTEC, INC.**

Tested By: Alexander \_\_\_\_\_

Checked By: Hamlett \_\_\_\_\_



No.	Def. Dial in.	Load Dial	Load lbs.	Strain %	Deviator Stress ksf	Minor Eff. Stress ksf	Major Eff. Stress ksf	1:3 Ratio	Pore Press. psi	P ksf	Q ksf
0	0.0000	0.0	0.0	0.0	0.00	2.16	2.16	1.00	40.00	2.16	0.00
1	0.0100	113.0	81.4	0.2	1.95	1.50	3.45	2.30	44.60	2.47	0.98
2	0.0200	136.0	97.9	0.3	2.35	1.22	3.57	2.92	46.50	2.40	1.17
3	0.0300	155.0	111.6	0.5	2.67	1.05	3.72	3.54	47.70	2.39	1.34
4	0.0400	174.0	125.3	0.7	2.99	0.98	3.97	4.06	48.20	2.48	1.50
5	0.0500	192.0	138.2	0.9	3.30	0.92	4.22	4.58	48.60	2.57	1.65
6	0.0600	210.0	151.2	1.0	3.60	0.86	4.46	5.17	49.00	2.66	1.80
7	0.0700	228.0	164.2	1.2	3.90	0.88	4.78	5.44	48.90	2.83	1.95
8	0.0800	245.0	176.4	1.4	4.19	0.91	5.09	5.61	48.70	3.00	2.09
9	0.0900	260.0	187.2	1.5	4.43	0.96	5.40	5.60	48.30	3.18	2.22
10	0.1000	275.0	198.0	1.7	4.68	1.01	5.69	5.64	48.00	3.35	2.34
11	0.2000	341.0	245.5	3.4	5.70	1.37	7.07	5.17	45.50	4.22	2.85
12	0.3000	360.0	259.2	5.1	5.92	1.51	7.43	4.91	44.50	4.47	2.96
13	0.4000	359.0	258.5	6.8	5.79	1.58	7.38	4.66	44.00	4.48	2.90
14	0.5000	374.0	269.3	8.5	5.93	1.64	7.57	4.61	43.60	4.60	2.96
15	0.6000	377.0	271.4	10.2	5.86	1.71	7.58	4.42	43.10	4.64	2.93
16	0.7000	388.0	279.4	11.9	5.92	1.77	7.69	4.34	42.70	4.73	2.96
17	0.8000	394.0	283.7	13.6	5.89	1.86	7.75	4.17	42.10	4.80	2.95
18	0.9000	403.0	290.2	15.4	5.91	1.94	7.85	4.04	41.50	4.90	2.95
19	1.0000	423.0	304.6	17.1	6.08	2.06	8.14	3.95	40.70	5.10	3.04
20	1.1000	427.0	307.4	18.8	6.01	2.13	8.14	3.82	40.20	5.14	3.00
21	1.2000	425.0	306.0	20.5	5.85	2.15	8.00	3.73	40.10	5.07	2.93

Specimen Parameter	Initial	Saturated	Consolidated	Final
Moisture content: Moist soil+tare, gms.	1276.900			1287.540
Moisture content: Dry soil+tare, gms.	1072.800			1079.980
Moisture content: Tare, gms.	0.000			14.190
Moisture, %	19.0	21.9	17.4	19.5
Moist specimen weight, gms.	1282.0			
Diameter, in.	2.86	2.86	2.78	
Area, in. <sup>2</sup>	6.41	6.41	6.08	
Height, in.	6.10	6.10	5.94	
Net decrease in height, in.		0.00	0.16	
Wet Density, pcf	125.0	128.0	133.3	
Dry density, pcf	105.0	105.0	113.6	
Void ratio	0.5815	0.5815	0.4622	
Saturation, %	87.0	100.0	100.0	

Load ring constant = 0.72 lbs. per input unit

Consolidation cell pressure = 70.00 psi (10.08 ksf)

Consolidation back pressure = 40.00 psi (5.76 ksf)

Consolidation effective confining stress = 4.32 ksf

Strain rate, in./min. = 0.02

Fail. Stress = 7.05 ksf at reading no. 15

No.	Def. Dial in.	Load Dial	Load lbs.	Strain %	Deviator Stress ksf	Minor Eff. Stress ksf	Major Eff. Stress ksf	1:3 Ratio	Pore Press. psi	P ksf	Q ksf
0	0.0000	0.0	0.0	0.0	0.00	4.32	4.32	1.00	40.00	4.32	0.00
1	0.0100	121.0	87.1	0.2	2.06	3.66	5.72	1.56	44.60	4.69	1.03
2	0.0200	161.0	115.9	0.3	2.74	3.25	5.99	1.84	47.40	4.62	1.37
3	0.0300	190.0	136.8	0.5	3.22	2.97	6.19	2.09	49.40	4.58	1.61
4	0.0400	209.0	150.5	0.7	3.54	2.72	6.26	2.30	51.10	4.49	1.77
5	0.0500	225.0	162.0	0.8	3.80	2.59	6.39	2.47	52.00	4.49	1.90
6	0.0600	238.0	171.4	1.0	4.02	2.46	6.48	2.63	52.90	4.47	2.01
7	0.0700	252.0	181.4	1.2	4.24	2.30	6.55	2.84	54.00	4.43	2.12
8	0.0800	264.0	190.1	1.3	4.44	2.22	6.66	3.00	54.60	4.44	2.22
9	0.0900	275.0	198.0	1.5	4.62	2.17	6.79	3.12	54.90	4.48	2.31
10	0.1000	285.0	205.2	1.7	4.78	2.16	6.94	3.21	55.00	4.55	2.39
11	0.2000	351.0	252.7	3.4	5.78	2.16	7.94	3.68	55.00	5.05	2.89
12	0.3000	401.0	288.7	5.1	6.49	2.26	8.75	3.87	54.30	5.51	3.24
13	0.4000	425.0	306.0	6.7	6.76	2.49	9.25	3.71	52.70	5.87	3.38
14	0.5000	451.0	324.7	8.4	7.04	2.62	9.66	3.69	51.80	6.14	3.52
15	0.6000	460.0	331.2	10.1	7.05	2.74	9.78	3.58	51.00	6.26	3.52
16	0.7000	465.0	334.8	11.8	6.99	2.89	9.89	3.42	49.90	6.39	3.50
17	0.8000	475.0	342.0	13.5	7.01	2.89	9.90	3.42	49.90	6.40	3.50
18	0.9000	485.0	349.2	15.2	7.01	2.89	9.91	3.42	49.90	6.40	3.51
19	1.0000	490.0	352.8	16.8	6.95	2.89	9.84	3.40	49.90	6.37	3.47
20	1.1000	502.0	361.4	18.5	6.97	3.07	10.04	3.27	48.70	6.55	3.49
21	1.2000	510.0	367.2	20.2	6.94	3.10	10.03	3.24	48.50	6.56	3.47

Specimen Parameter	Initial	Saturated	Consolidated	Final
Moisture content: Moist soil+tare, gms.	1129.800			1141.260
Moisture content: Dry soil+tare, gms.	867.600			881.520
Moisture content: Tare, gms.	0.000			14.240
Moisture, %	30.2	34.0	28.7	29.9
Moist specimen weight, gms.	1127.0			
Diameter, in.	2.82	2.82	2.74	
Area, in. <sup>2</sup>	6.23	6.23	5.92	
Height, in.	6.07	6.07	5.92	
Net decrease in height, in.		0.00	0.15	
Wet Density, pcf	113.5	116.8	121.2	
Dry density, pcf	87.2	87.2	94.2	
Void ratio	0.9051	0.9051	0.7625	
Saturation, %	88.8	100.0	100.0	

Load ring constant = 0.72 lbs. per input unit

Consolidation cell pressure = 100.00 psi (14.40 ksf)

Consolidation back pressure = 40.00 psi (5.76 ksf)

Consolidation effective confining stress = 8.64 ksf

Strain rate, in./min. = 0.02

Fail. Stress = 9.48 ksf at reading no. 12

No.	Def. Dial in.	Load Dial	Load lbs.	Strain %	Deviator Stress ksf	Minor Eff. Stress ksf	Major Eff. Stress ksf	1:3 Ratio	Pore Press. psi	P ksf	Q ksf
0	0.0000	0.0	0.0	0.0	0.00	8.64	8.64	1.00	40.00	8.64	0.00
1	0.0100	246.0	177.1	0.2	4.30	7.98	12.28	1.54	44.60	10.13	2.15
2	0.0200	378.0	272.2	0.3	6.60	7.68	14.28	1.86	46.70	10.98	3.30
3	0.0300	436.0	313.9	0.5	7.60	7.32	14.92	2.04	49.20	11.12	3.80
4	0.0400	461.0	331.9	0.7	8.02	7.04	15.07	2.14	51.10	11.05	4.01
5	0.0500	476.0	342.7	0.8	8.27	6.83	15.10	2.21	52.60	10.96	4.14
6	0.0600	487.0	350.6	1.0	8.45	6.62	15.07	2.28	54.00	10.85	4.22
7	0.0700	496.0	357.1	1.2	8.59	6.47	15.05	2.33	55.10	10.76	4.29
8	0.0800	502.0	361.4	1.4	8.68	6.35	15.03	2.37	55.90	10.69	4.34
9	0.0900	507.0	365.0	1.5	8.75	6.26	15.01	2.40	56.50	10.64	4.37
10	0.1000	517.0	372.2	1.7	8.91	6.06	14.97	2.47	57.90	10.52	4.45
11	0.2000	553.0	398.2	3.4	9.36	5.04	14.40	2.86	65.00	9.72	4.68
12	0.3000	570.0	410.4	5.1	9.48	4.65	14.13	3.04	67.70	9.39	4.74
13	0.4000	575.0	414.0	6.8	9.40	4.62	14.02	3.03	67.90	9.32	4.70
14	0.5000	564.0	406.1	8.5	9.05	4.41	13.45	3.05	69.40	8.93	4.52
15	0.6000	554.0	398.9	10.1	8.72	4.46	13.19	2.95	69.00	8.83	4.36
16	0.6500	550.0	396.0	11.0	8.58	4.49	13.07	2.91	68.80	8.78	4.29



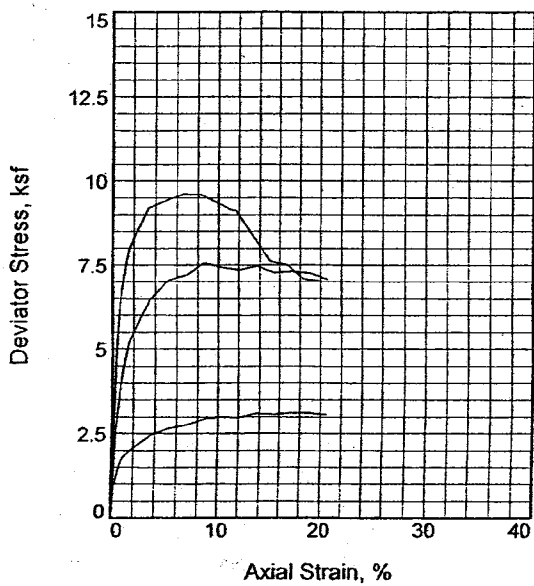
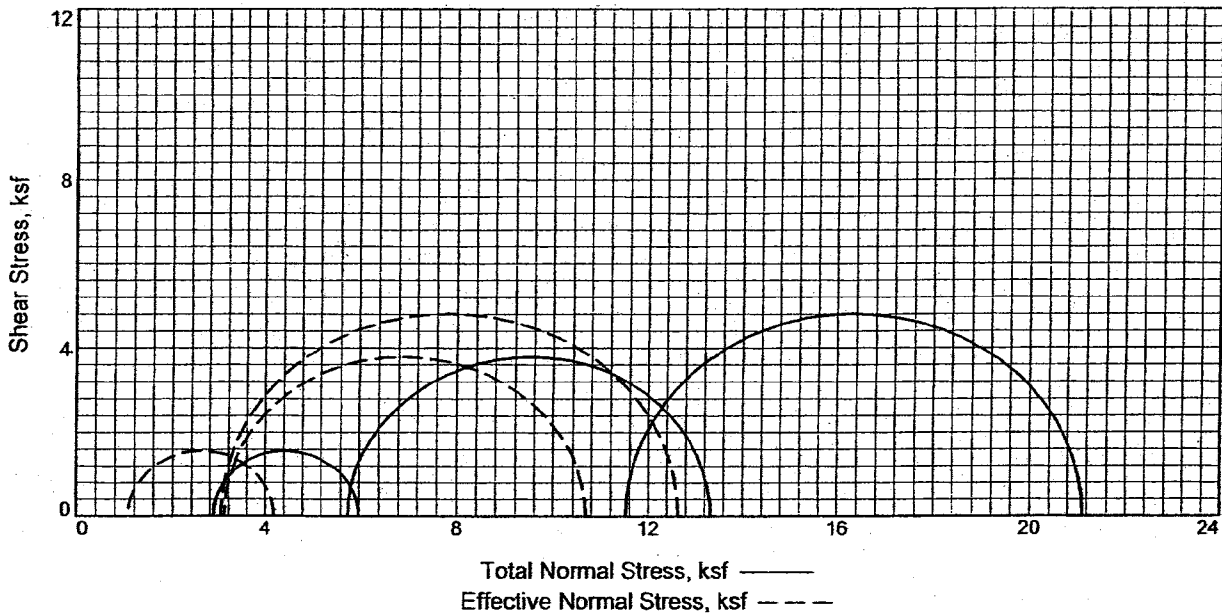

Sample No.		1	2	3
Initial	Water Content,	39.1	21.6	26.5
	Dry Density, pcf	81.0	100.1	94.0
	Saturation,	99.8	88.2	92.9
	Void Ratio	1.0350	0.6468	0.7536
	Diameter, in.	2.85	2.75	2.84
	Height, in.	5.98	5.96	6.11
At Test	Water Content,	32.8	19.3	24.4
	Dry Density, pcf	88.3	109.2	100.3
	Saturation,	100.0	100.0	100.0
	Void Ratio	0.8666	0.5095	0.6432
	Diameter, in.	2.77	2.67	2.78
	Height, in.	5.81	5.79	5.98
	Strain rate, in./min.	0.02	0.02	0.02
	Back Pressure, ksf	2.9	2.9	2.9
	Cell Pressure, ksf	5.8	8.6	14.4
	Fail. Stress, ksf	3.1	7.6	9.6
	Total Pore Pr., ksf	4.7	5.5	11.4
	Ult. Stress, ksf			
	Total Pore Pr., ksf			
	$\bar{\sigma}_1$ Failure, ksf	4.2	10.7	12.6
	$\bar{\sigma}_3$ Failure, ksf	1.1	3.1	3.0

**Type of Test:**

CU with Pore Pressures

**Sample Type:** undisturbed

**Description:** Brown sandy elastic silt

LL= 53

PL= 29

PI= 24

Specific Gravity= 2.64

Remarks: MH

**Client:** TVA

**Project:** TVA Kingston - Proposed Gypsum Stack

**Location:** NB-77A

**Sample Number:** UD-4, 5 & 7 (CU)

**Depth:** 15'-26'

**Proj. No.:** 3043051021

**Date:**

TRIAXIAL SHEAR TEST REPORT

**MACTEC, INC.**

Figure \_\_\_\_\_

Tested By: Alexander

Checked By: Hamlett

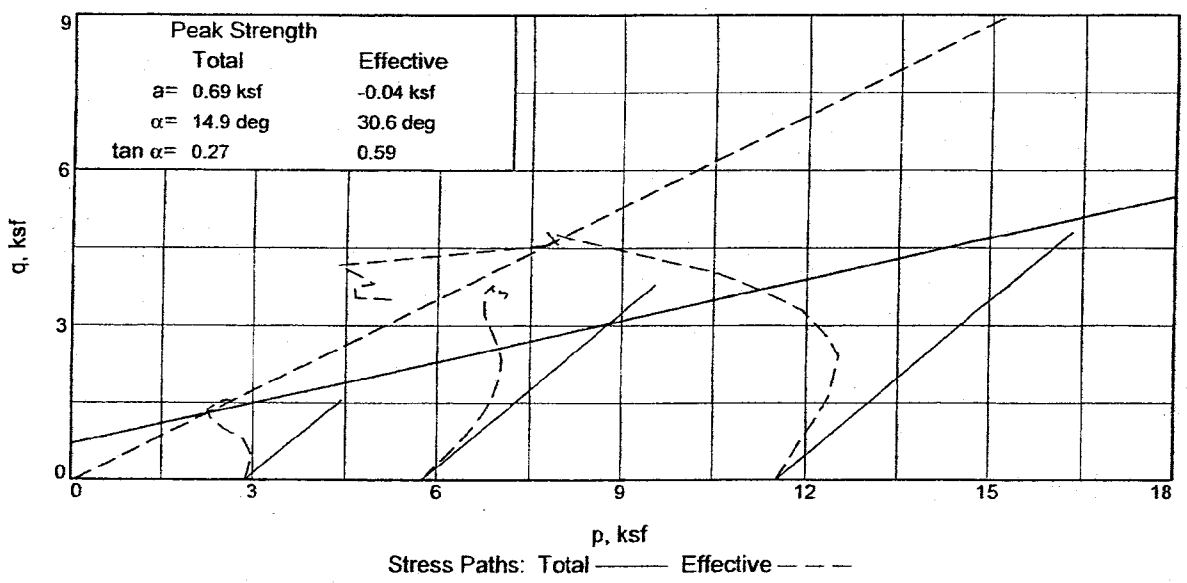
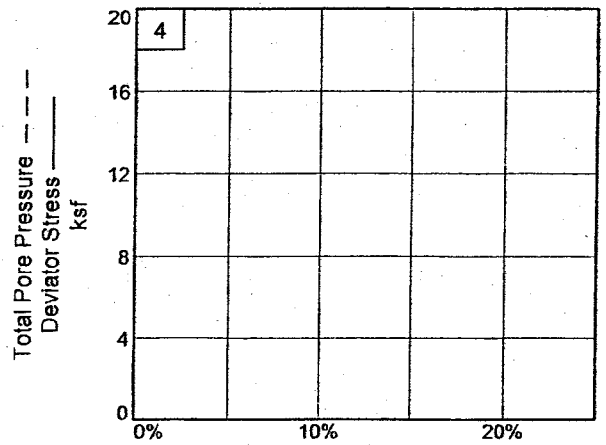
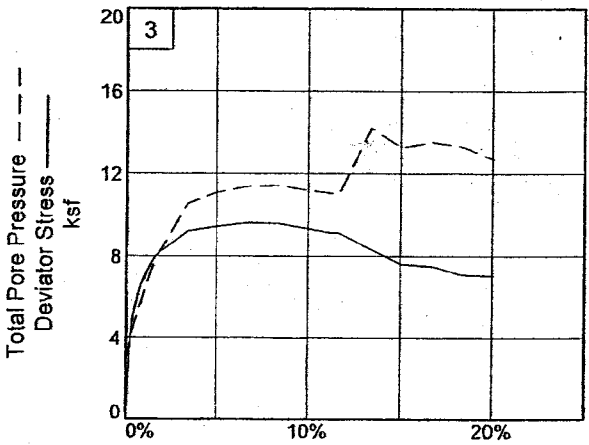
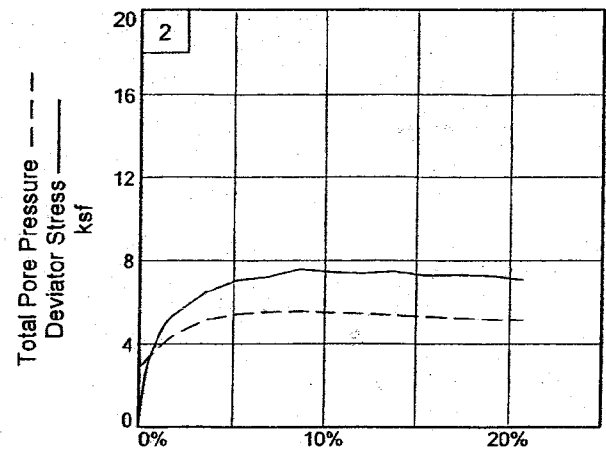
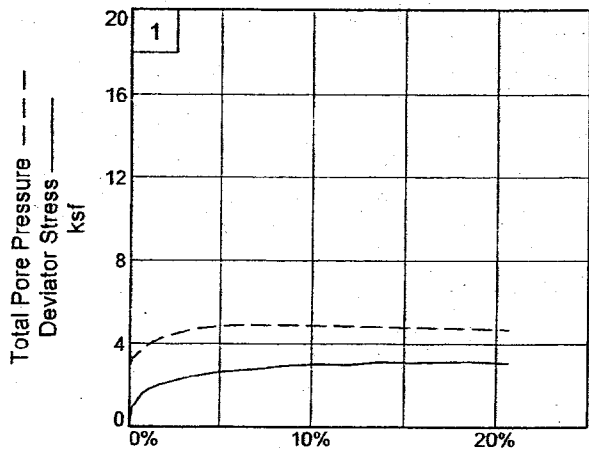

Client: TVA  
 Project: TVA Kingston - Proposed Gypsum Stack  
 Location: NB-77A      Depth: 15'-26'      Sample Number: UD-4, 5 & 7 (CU)  
 Project No.: 3043051021      Figure \_\_\_\_\_      **MACTEC, INC.**

Tested By: Alexander      Checked By: Hamlett

**TRIAXIAL COMPRESSION TEST**  
CU with Pore Pressures

9/16/2005  
10:57 AM

Date: \_\_\_\_\_  
 Client: TVA  
 Project: TVA Kingston - Proposed Gypsum Stack  
 Project No.: 3043051021  
 Location: NB-77A  
 Depth: 15'-26' Sample Number: UD-4, 5 & 7 (CU)  
 Description: Brown sandy elastic silt  
 Remarks: MH  
 Type of Sample: undisturbed  
 Specific Gravity=2.64 LL=53 PL=29 PI=24  
 Test Method: COE uniform strain

Parameters on Specimen No. 1				
Specimen Parameter	Initial	Saturated	Consolidated	Final
Moisture content: Moist soil+tare, gms.	1119.100			550.490
Moisture content: Dry soil+tare, gms.	804.330			392.810
Moisture content: Tare, gms.	0.000			13.640
Moisture, %	39.1	39.2	32.8	41.6
Moist specimen weight, gms.	1126.9			
Diameter, in.	2.85	2.85	2.77	
Area, in. <sup>2</sup>	6.37	6.37	6.02	
Height, in.	5.98	5.98	5.81	
Net decrease in height, in.		0.00	0.17	
Wet Density, pcf	112.7	112.7	117.3	
Dry density, pcf	81.0	81.0	88.3	
Void ratio	1.0350	1.0350	0.8666	
Saturation, %	99.8	100.0	100.0	

Load ring constant = 0.72 lbs. per input unit  
 Consolidation cell pressure = 40.00 psi (5.76 ksf)  
 Consolidation back pressure = 20.00 psi (2.88 ksf)  
 Consolidation effective confining stress = 2.88 ksf  
 Strain rate, in./min. = 0.02  
 Fail. Stress = 3.12 ksf at reading no. 20

Test Results for Specimen No.

No.	Def. Dial in.	Load Dial	Load lbs.	Strain %	Deviator Stress ksf	Minor Eff. Stress ksf	Major Eff. Stress ksf	1:3 Ratio	Pore Press. psi	P ksf	Q ksf
0	0.0000	0.0	0.0	0.0	0.00	2.88	2.88	1.00	20.00	2.88	0.00
1	0.0100	54.0	38.9	0.2	0.93	2.52	3.45	1.37	22.50	2.98	0.46
2	0.0200	67.0	48.2	0.3	1.15	2.36	3.51	1.49	23.60	2.94	0.58
3	0.0300	80.0	57.6	0.5	1.37	2.20	3.57	1.62	24.70	2.89	0.69
4	0.0400	92.0	66.2	0.7	1.57	2.06	3.63	1.76	25.70	2.85	0.79
5	0.0500	99.0	71.3	0.9	1.69	1.94	3.64	1.87	26.50	2.79	0.85
6	0.0600	105.0	75.6	1.0	1.79	1.81	3.61	1.99	27.40	2.71	0.90
7	0.0700	108.0	77.8	1.2	1.84	1.71	3.55	2.07	28.10	2.63	0.92
8	0.0800	112.0	80.6	1.4	1.90	1.66	3.56	2.15	28.50	2.61	0.95
9	0.0900	116.0	83.5	1.5	1.97	1.57	3.54	2.25	29.10	2.55	0.98
10	0.1000	119.0	85.7	1.7	2.02	1.51	3.53	2.33	29.50	2.52	1.01
11	0.2000	145.0	104.4	3.4	2.41	1.09	3.51	3.20	32.40	2.30	1.21
12	0.3000	162.0	116.6	5.2	2.65	0.94	3.58	3.83	33.50	2.26	1.32
13	0.4000	171.0	123.1	6.9	2.74	0.89	3.64	4.07	33.80	2.26	1.37
14	0.5000	186.0	133.9	8.6	2.93	0.91	3.84	4.23	33.70	2.37	1.46
15	0.6000	194.0	139.7	10.3	3.00	0.92	3.92	4.25	33.60	2.42	1.50
16	0.7000	196.0	141.1	12.1	2.97	0.95	3.92	4.13	33.40	2.44	1.49
17	0.8000	209.0	150.5	13.8	3.11	0.98	4.08	4.17	33.20	2.53	1.55
18	0.9000	211.0	151.9	15.5	3.07	1.01	4.08	4.05	33.00	2.54	1.54
19	1.0000	218.0	157.0	17.2	3.11	1.04	4.15	4.00	32.80	2.59	1.55
20	1.1000	223.0	160.6	18.9	3.12	1.07	4.18	3.92	32.60	2.62	1.56
21	1.2000	224.0	161.3	20.7	3.06	1.11	4.17	3.76	32.30	2.64	1.53

Specimen Parameter	Initial	Saturated	Consolidated	Final
Moisture content: Moist soil+tare, gms.	1077.430			648.960
Moisture content: Dry soil+tare, gms.	886.000			507.890
Moisture content: Tare, gms.	0.000			13.720
Moisture, %	21.6	24.5	19.3	28.5
Moist specimen weight, gms.	1132.3			
Diameter, in.	2.75	2.75	2.67	
Area, in. <sup>2</sup>	5.94	5.94	5.61	
Height, in.	5.96	5.96	5.79	
Net decrease in height, in.		0.00	0.17	
Wet Density, pcf	121.7	124.6	130.3	
Dry density, pcf	100.1	100.1	109.2	
Void ratio	0.6468	0.6468	0.5095	
Saturation, %	88.2	100.0	100.0	

Load ring constant = 0.72 lbs. per input unit

Consolidation cell pressure = 60.00 psi (8.64 ksf)

Consolidation back pressure = 20.00 psi (2.88 ksf)

Consolidation effective confining stress = 5.76 ksf

Strain rate, in./min. = 0.02

Fail. Stress = 7.57 ksf at reading no. 14

No.	Def. Dial in.	Load Dial	Load lbs.	Strain %	Deviator Stress ksf	Minor Eff. Stress ksf	Major Eff. Stress ksf	1:3 Ratio	Pore Press. psi	P ksf	Q ksf
0	0.0000	0.0	0.0	0.0	0.00	5.76	5.76	1.00	20.00	5.76	0.00
1	0.0100	88.0	63.4	0.2	1.62	5.62	7.24	1.29	21.00	6.43	0.81
2	0.0200	144.0	103.7	0.3	2.65	5.44	8.10	1.49	22.20	6.77	1.33
3	0.0300	175.0	126.0	0.5	3.22	5.28	8.50	1.61	23.30	6.89	1.61
4	0.0400	200.0	144.0	0.7	3.67	5.13	8.80	1.72	24.40	6.96	1.84
5	0.0500	221.0	159.1	0.9	4.05	4.98	9.03	1.81	25.40	7.01	2.03
6	0.0600	240.0	172.8	1.0	4.39	4.82	9.22	1.91	26.50	7.02	2.20
7	0.0700	256.0	184.3	1.2	4.68	4.69	9.37	2.00	27.40	7.03	2.34
8	0.0800	270.0	194.4	1.4	4.92	4.55	9.47	2.08	28.40	7.01	2.46
9	0.0900	283.0	203.8	1.6	5.15	4.42	9.57	2.17	29.30	7.00	2.58
10	0.1000	292.0	210.2	1.7	5.31	4.31	9.61	2.23	30.10	6.96	2.65
11	0.2000	360.0	259.2	3.5	6.43	3.54	9.97	2.81	35.40	6.76	3.21
12	0.3000	401.0	288.7	5.2	7.03	3.24	10.27	3.17	37.50	6.76	3.52
13	0.4000	418.0	301.0	6.9	7.20	3.14	10.33	3.29	38.20	6.74	3.60
14	0.5000	448.0	322.6	8.6	7.57	3.11	10.68	3.43	38.40	6.89	3.78
15	0.6000	448.0	322.6	10.4	7.43	3.17	10.59	3.34	38.00	6.88	3.71
16	0.7000	452.0	325.4	12.1	7.35	3.21	10.56	3.29	37.70	6.89	3.67
17	0.8000	468.0	337.0	13.8	7.46	3.28	10.74	3.27	37.20	7.01	3.73
18	0.9000	465.0	334.8	15.5	7.26	3.36	10.62	3.16	36.70	6.99	3.63
19	1.0000	477.0	343.4	17.3	7.30	3.43	10.73	3.13	36.20	7.08	3.65
20	1.1000	484.0	348.5	19.0	7.25	3.50	10.75	3.07	35.70	7.12	3.63
21	1.2000	482.0	347.0	20.7	7.07	3.54	10.61	2.99	35.40	7.08	3.53

Specimen Parameter	Initial	Saturated	Consolidated	Final
Moisture content: Moist soil+tare, gms.	1224.760			724.820
Moisture content: Dry soil+tare, gms.	968.090			580.180
Moisture content: Tare, gms.	0.000			13.810
Moisture, %	26.5	28.5	24.4	25.5
Moist specimen weight, gms.	1209.2			
Diameter, in.	2.84	2.84	2.78	
Area, in. <sup>2</sup>	6.34	6.34	6.07	
Height, in.	6.11	6.11	5.98	
Net decrease in height, in.		0.00	0.13	
Wet Density, pcf	118.9	120.8	124.7	
Dry density, pcf	94.0	94.0	100.3	
Void ratio	0.7536	0.7536	0.6432	
Saturation, %	92.9	100.0	100.0	

**TEST RESULTS OF SPECIMEN**

Load ring constant = 0.72 lbs. per input unit  
 Consolidation cell pressure = 100.00 psi (14.40 ksf)  
 Consolidation back pressure = 20.00 psi (2.88 ksf)  
 Consolidation effective confining stress = 11.52 ksf  
 Strain rate, in./min. = 0.02  
 Fail. Stress = 9.60 ksf at reading no. 13

No.	Def. Dial in.	Load Dial	Load lbs.	Strain %	Deviator Stress ksf	Minor Eff. Stress ksf	Major Eff. Stress ksf	1:3 Ratio	Pore Press. psi	P ksf	Q ksf
0	0.0000	0.0	0.0	0.0	0.00	11.52	11.52	1.00	20.00	11.52	0.00
1	0.0100	189.0	136.1	0.2	3.22	10.76	13.98	1.30	25.30	12.37	1.61
2	0.0200	282.0	203.0	0.3	4.80	10.14	14.94	1.47	29.60	12.54	2.40
3	0.0300	324.0	233.3	0.5	5.50	9.62	15.12	1.57	33.20	12.37	2.75
4	0.0400	363.0	261.4	0.7	6.16	9.03	15.18	1.68	37.30	12.11	3.08
5	0.0500	390.0	280.8	0.8	6.60	8.63	15.23	1.77	40.10	11.93	3.30
6	0.0600	412.0	296.6	1.0	6.96	8.14	15.10	1.86	43.50	11.62	3.48
7	0.0700	433.0	311.8	1.2	7.31	7.66	14.97	1.95	46.80	11.31	3.65
8	0.0800	451.0	324.7	1.3	7.60	7.23	14.82	2.05	49.80	11.03	3.80
9	0.0900	467.0	336.2	1.5	7.85	6.81	14.66	2.15	52.70	10.74	3.93
10	0.1000	480.0	345.6	1.7	8.06	6.49	14.55	2.24	54.90	10.52	4.03
11	0.2000	557.0	401.0	3.3	9.19	3.89	13.08	3.36	73.00	8.48	4.60
12	0.3000	581.0	418.3	5.0	9.42	3.34	12.76	3.82	76.80	8.05	4.71
13	0.4000	603.0	434.2	6.7	9.60	3.04	12.64	4.16	78.90	7.84	4.80
14	0.5000	613.0	441.4	8.4	9.59	2.98	12.57	4.22	79.30	7.78	4.79
15	0.6750	603.0	434.2	11.3	9.13	3.37	12.50	3.71	76.60	7.94	4.57
16	0.7000	606.0	436.3	11.7	9.13	3.40	12.53	3.69	76.40	7.97	4.57
17	0.8000	564.0	406.1	13.4	8.34	0.20	8.54	42.37	98.60	4.37	4.17
18	0.9000	525.0	378.0	15.1	7.61	1.15	8.76	7.61	92.00	4.96	3.81
19	1.0000	528.0	380.2	16.7	7.51	0.88	8.38	9.54	93.90	4.63	3.75
20	1.1000	508.0	365.8	18.4	7.08	1.11	8.18	7.38	92.30	4.65	3.54
21	1.2000	514.0	370.1	20.1	7.01	1.73	8.74	5.06	88.00	5.23	3.51

## CONSOLIDATED UNDRAINED TRIAXIAL TEST by ASTM D4767

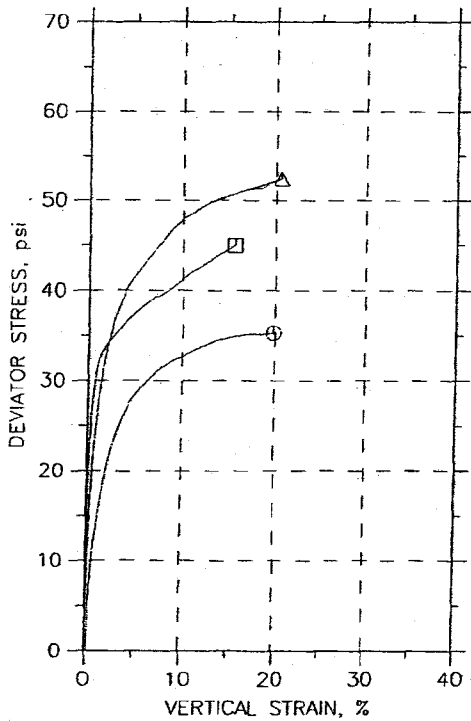
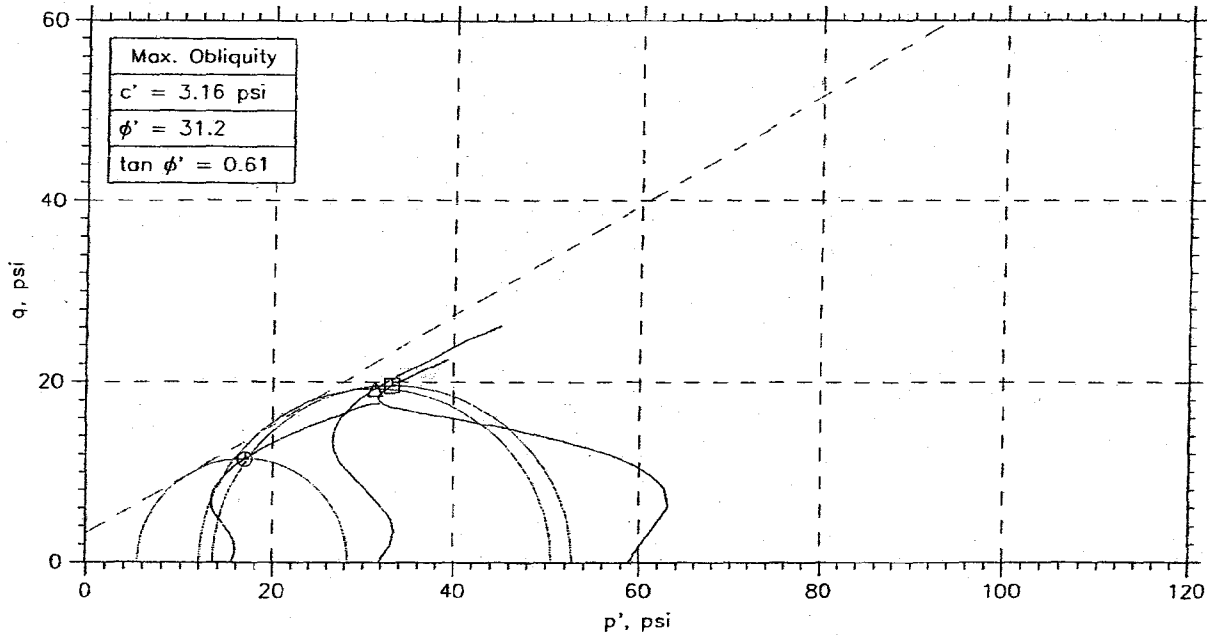

Symbol	⊙	△	⊠	
Sample No.	UD-2	UD-1	UD-1	
Test No.	13766.1	13765.2	13765.4	
Depth	13-15 Ft.	11-12.8 Ft.	11-12.8 ft	
Initial	Diameter, in	2.852	2.833	2.848
	Height, in	5.57	5.57	5.57
	Water Content, %	35.2	24.8	22.6
	Dry Density, pcf	85.2	97.98	98.28
	Saturation, %	95.2	90.6	83.1
Before Shear	Void Ratio	1.02	0.754	0.749
	Water Content, %	36.2	25.3	22.0
	Dry Density, pcf	86.05	101.2	107.
	Saturation*, %	100.0	100.0	100.0
	Void Ratio	0.997	0.698	0.606
	Back Press., psi	64	49.99	90
Ver. Eff. Cons. Stress, psi	15	30	60	
Shear Strength, psi	17.62	26.2	22.48	
Strain at Failure, %	19.8	20.6	15.5	
Strain Rate, %/min	0.022	0.00124	0.022	
B-Value	0.95	0.95	0.95	
Measured Specific Gravity	2.75	2.75	2.75	
Liquid Limit	75	50	50	
Plastic Limit	31	24	24	

<b>GeoTesting</b> press <small>groundwork for success</small>	Project: TVA Kingston Gypsum Stock			
	Location: NB-77B			
	Project No.: GTX G0959			
	Boring No.: NB-77B			
	Sample Type: Shelby Tube			
Description:				
Remarks:				

Phase calculations based on start and end of test.

\* Saturation is set to 100% for phase calculations.

# CONSOLIDATED UNDRAINED TRIAXIAL TEST by ASTM D4767

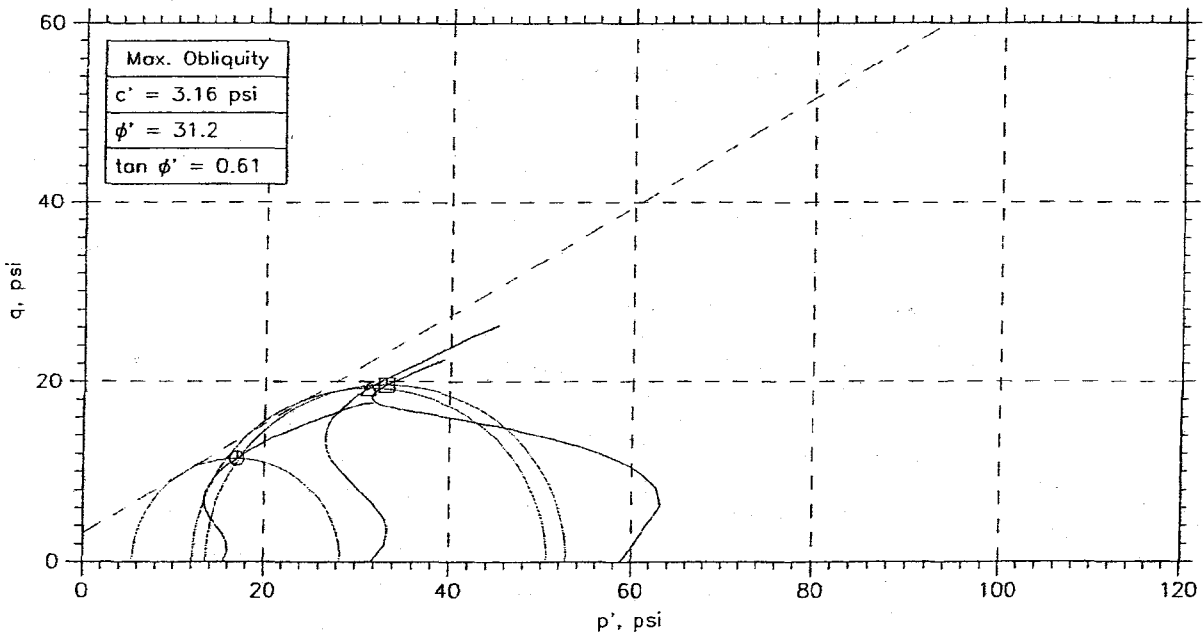
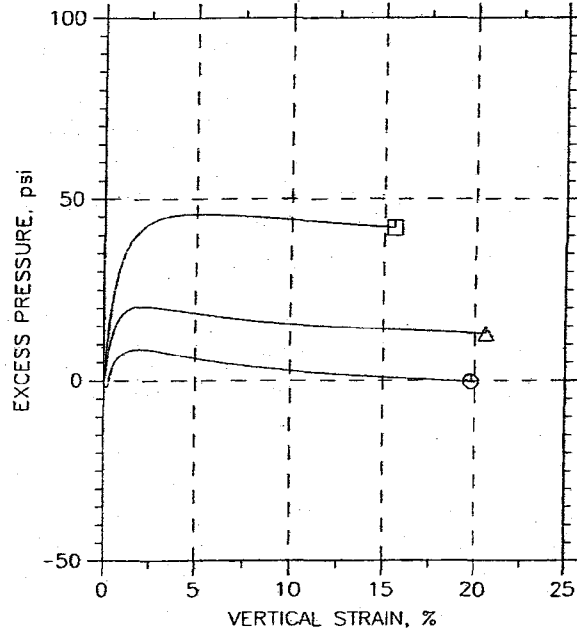
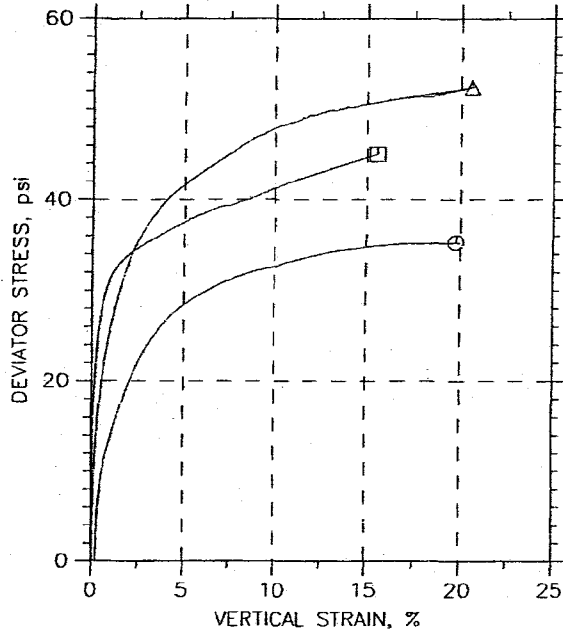

	Sample No.	Test No.	Depth	Tested By	Test Date	Checked By	Check Date	Test File
○	UD-2	13766.1	13-15 Ft.	HJ	11/30/05	JW		13766.1o_1057.dat
△	UD-1	13765.2	11-12.8 Ft.	HJ	11/30/05	JW		13765.2_2054.dat
□	UD-1	13765.4	11-12.8 ft	JW	12/5/05	HJ		13765.4_1057.dat

<b>GeoTesting</b> <b>express</b> <small>the groundwork for success</small>	Project: TVA Kingston Gypsum Station		Location: NB-77B	Project No.: GTX G0959
	Boring No.: NB-77B		Sample Type: Shelby Tube	
	Description:			
	Remarks:			



## CONSOLIDATED UNDRAINED TRIAXIAL TEST by ASTM D4767

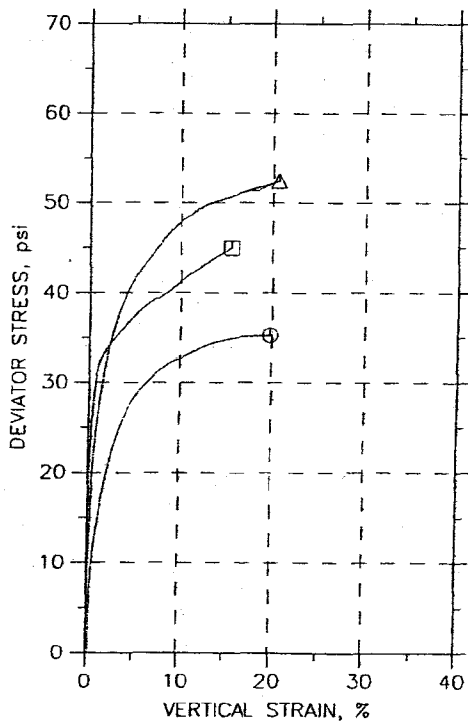
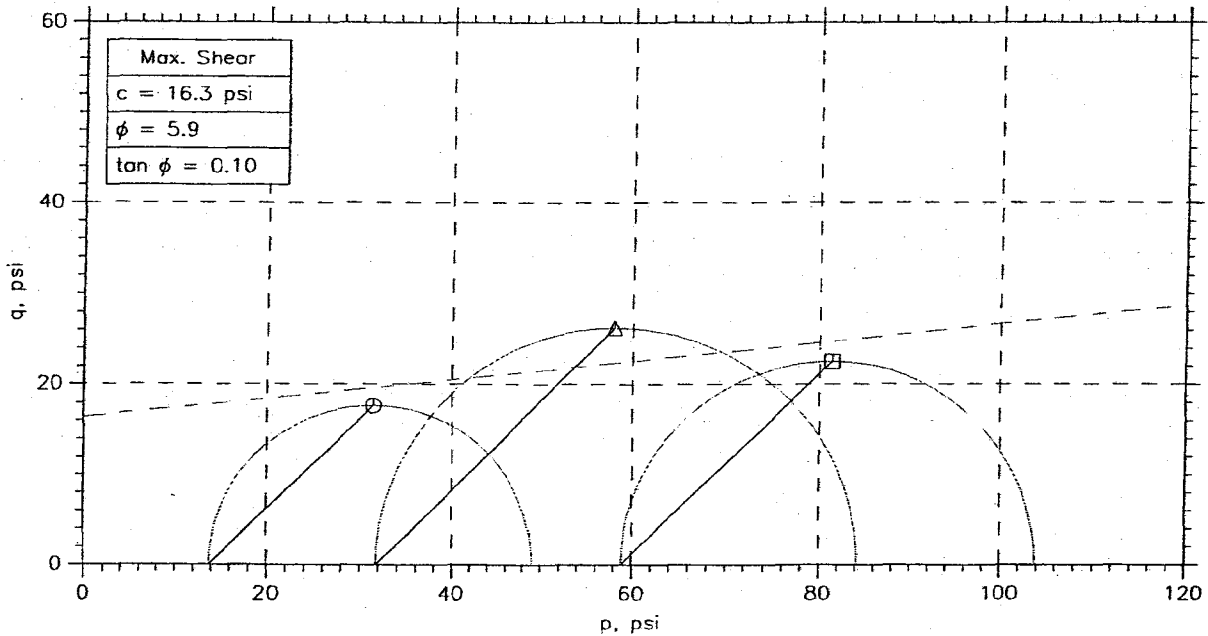

Symbol	⊙	△	□	
Sample No.	UD-2	UD-1	UD-1	
Test No.	13766.1	13765.2	13765.4	
Depth	13-15 FL	1-12.8 Ft	1-12.8 ft	
Initial	Diameter, in	2.852	2.833	2.848
	Height, in	5.57	5.57	5.57
	Water Content, %	35.2	24.8	22.6
	Dry Density, pcf	85.2	97.98	98.28
	Saturation, %	95.2	90.6	83.1
Before Shear	Void Ratio	1.02	0.754	0.749
	Water Content, %	36.2	25.3	22.0
	Dry Density, pcf	86.05	101.2	107.
	Saturation, %	100.0	100.0	100.0
Void Ratio	0.997	0.698	0.606	
Back Press., psi	64	49.99	90	
Ver. Eff. Cons. Stress, psi	15	30	60	
Shear Strength, psi	17.62	26.2	22.48	
Strain at Failure, %	19.8	20.6	15.5	
Strain Rate, %/min	0.022	0.00124	0.022	
B-Value	0.95	0.95	0.95	
Measured Specific Gravity	2.75	2.75	2.75	
Liquid Limit	75	50	50	
Plastic Limit	31	24	24	

<b>GeoTesting</b> express <small>the groundwork for success</small>	Project: TVA Kingston Gypsym Stack				
	Location: NB-77B				
	Project No.: GTX G0959				
	Boring No.: NB-77B				
	Sample Type: Shelby Tube				
	Description:				
Remarks:					

Phase calculations based on start and end of test.

\* Saturation is set to 100% for phase calculations.

# CONSOLIDATED UNDRAINED TRIAXIAL TEST by ASTM D4767

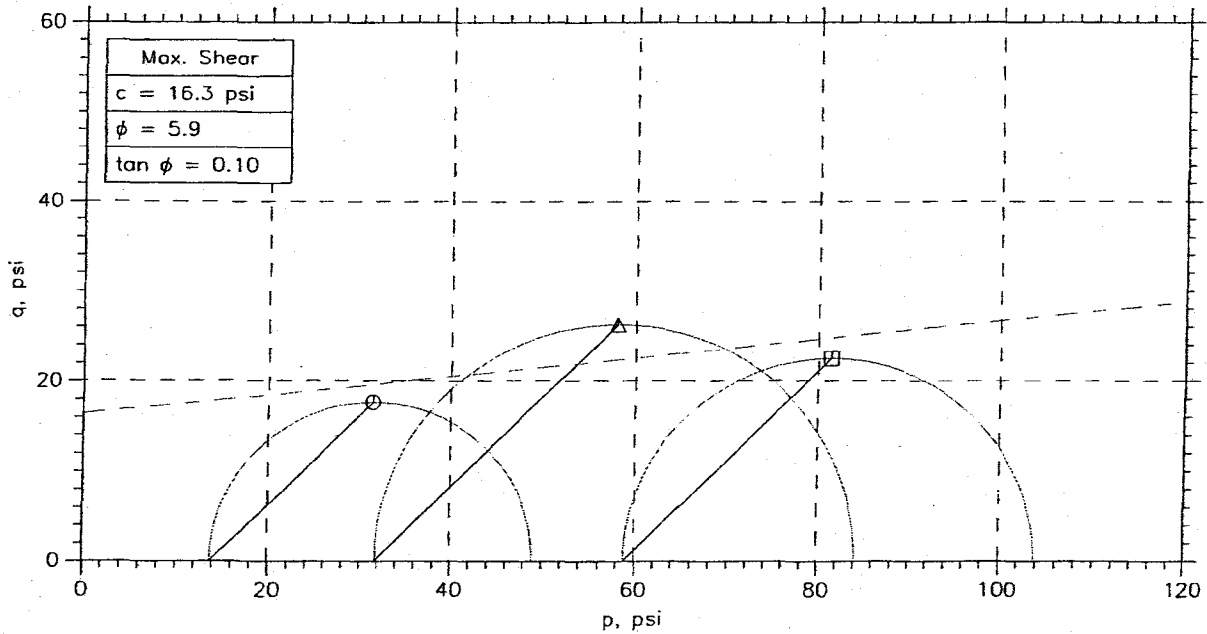
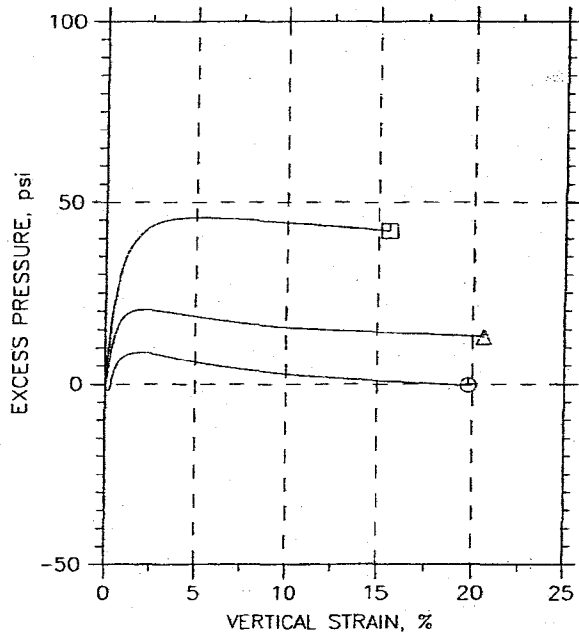
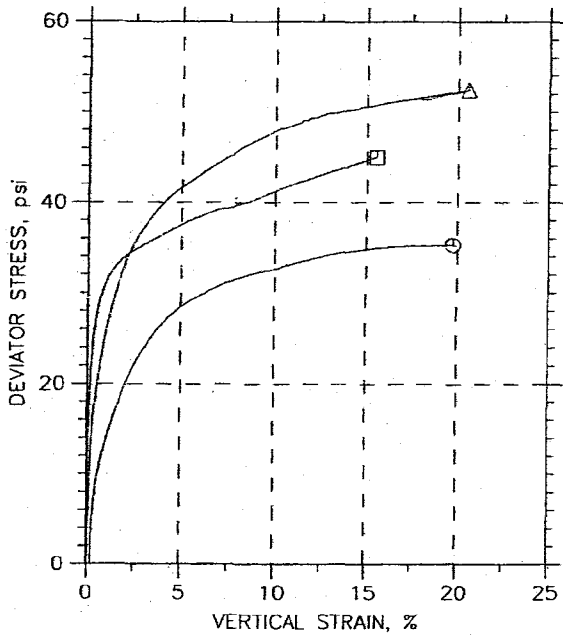

	Sample No.	Test No.	Depth	Tested By	Test Date	Checked By	Check Date	Test File
○	UD-2	13766.1	13-15 Ft.	HJ	11/30/05	JW		13766.1a_1057.dat
△	UD-1	13765.2	11-12.8 Ft.	HJ	11/30/05	JW		13765.2_2054.dat
□	UD-1	13765.4	11-12.8 ft	JW	12/5/05	HJ		13765.4_1057.dat

<b>Geotesting express</b> <small>the groundwork for success</small>	Project: TVA Kingston Gypsum Station		Location: NB-77B		Project No.: GTX G0959	
	Boring No.: NB-77B		Sample Type: Shelby Tube			
	Description:					
	Remarks:					

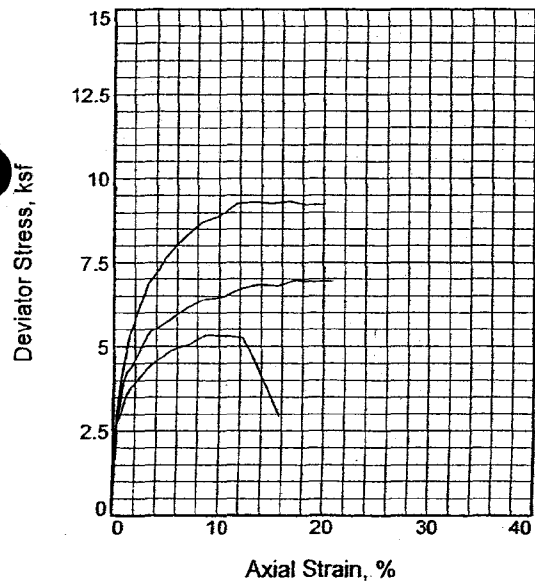
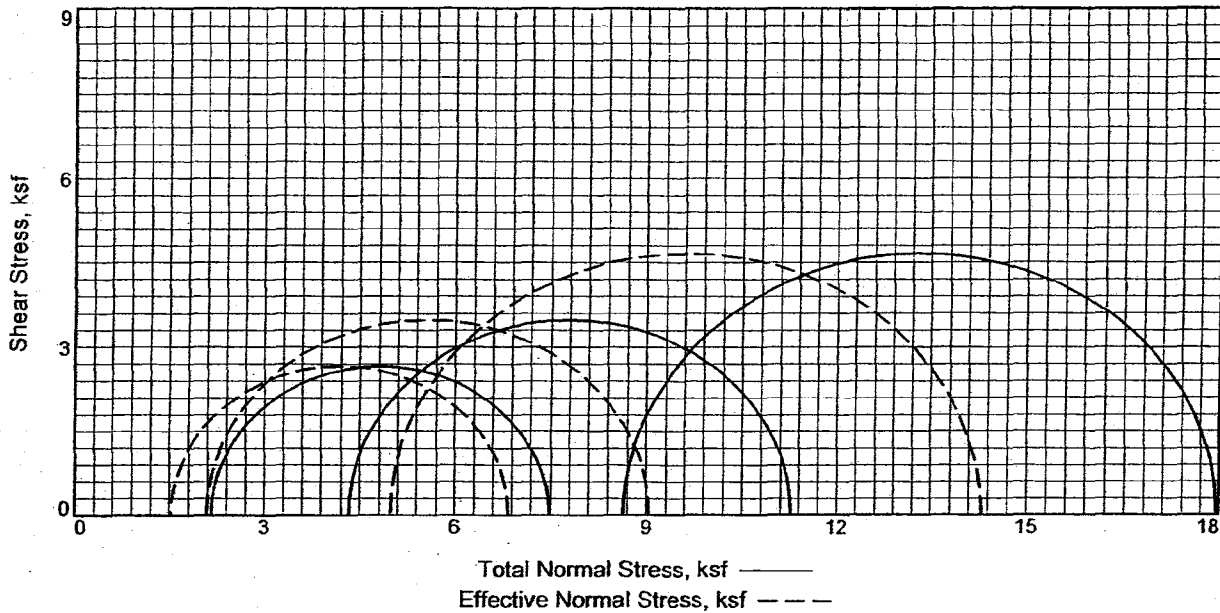

Sample No.		1	2	3
Initial	Water Content,	18.7	19.5	23.0
	Dry Density, pcf	104.0	104.7	101.7
	Saturation,	83.3	88.7	96.5
	Void Ratio	0.5963	0.5862	0.6330
	Diameter, in.	2.94	2.94	2.85
	Height, in.	5.76	5.85	6.05
At Test	Water Content,	20.4	19.9	21.4
	Dry Density, pcf	107.6	108.6	105.8
	Saturation,	100.0	100.0	100.0
	Void Ratio	0.5435	0.5297	0.5696
	Diameter, in.	2.91	2.91	2.81
	Height, in.	5.70	5.78	5.98
Strain rate, in./min.		0.01	0.01	0.01
Back Pressure, ksf		5.8	5.8	5.8
Cell Pressure, ksf		7.9	10.1	14.4
Fail. Stress, ksf		5.3	7.0	9.3
Total Pore Pr., ksf		6.4	8.0	9.4
Ult. Stress, ksf				
Total Pore Pr., ksf				
$\bar{\sigma}_1$	Failure, ksf	6.8	9.0	14.3
$\bar{\sigma}_3$	Failure, ksf	1.5	2.1	5.0

**Type of Test:**

CU with Pore Pressures

**Sample Type:** undisturbed

**Description:** Brownish yellow clayey sand with gravel

LL= 59

PL= 30

PI= 29

**Specific Gravity=** 2.66

**Remarks:** SC

**Client:** TVA

**Project:** TVA Kingston - Proposed Gypsum Stack

**Location:** NB-85A/B

**Sample Number:** UD-1, 2 & 3 (CU)

**Depth:** 13'-19'

**Proj. No.:** 3043051021

**Date:**

TRIAXIAL SHEAR TEST REPORT

**MACTEC, INC.**

Figure \_\_\_\_\_

Tested By: Alexander

Checked By: Hamlett

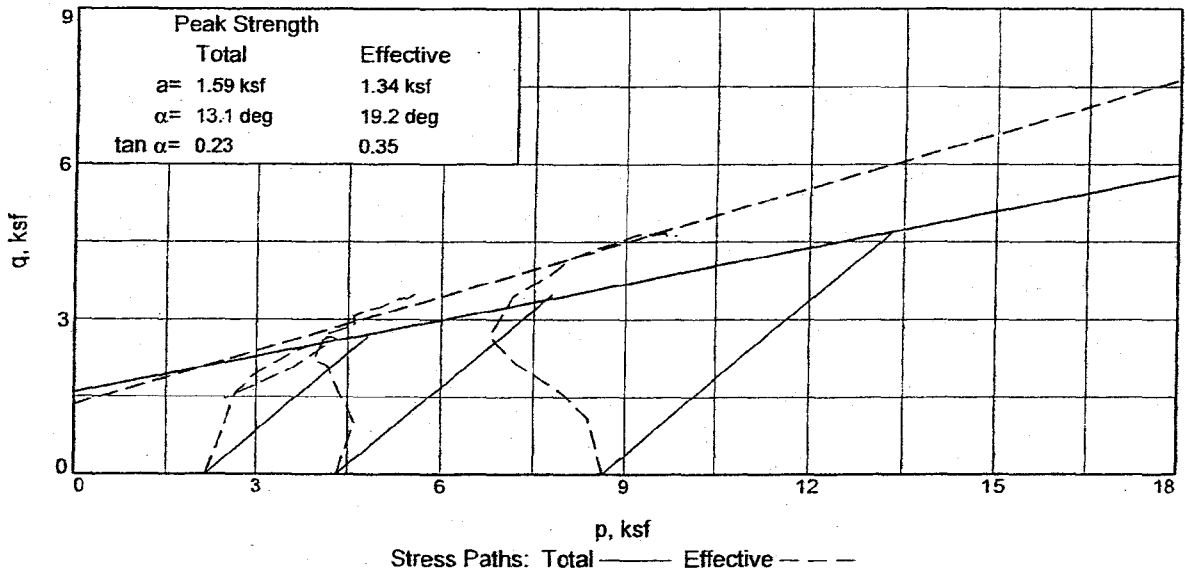
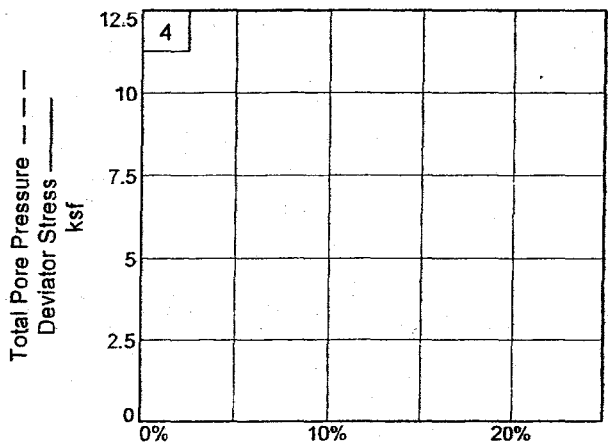
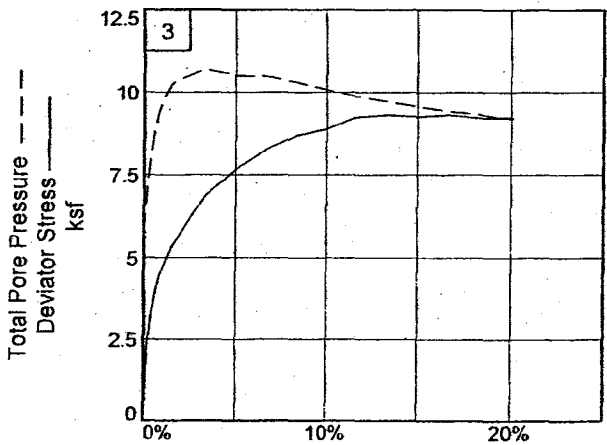
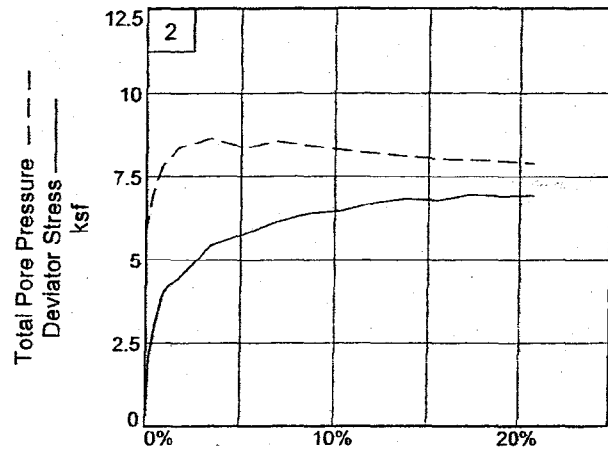
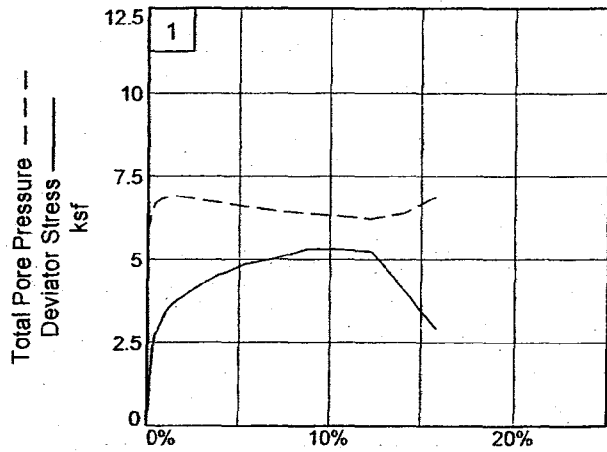

Client: TVA

Project: TVA Kingston - Proposed Gypsum Stack

Location: NB-85A and NB-85B

Depth: 13'-19'

Sample Number: UD-1, 2 & 3 (CU)

Project No.: 3043051021

Figure \_\_\_\_\_

**MACTEC, INC.**

Tested By: Alexander

Checked By: Hamlett



No.	Def. Dial in.	Load Dial	Load lbs.	Strain %	Deviator Stress ksf	Minor Eff. Stress ksf	Major Eff. Stress ksf	1:3 Ratio	Pore Press. psi	P ksf	Q ksf
0	0.0000	0.0	0.0	0.0	0.00	2.16	2.16	1.00	40.00	2.16	0.00
1	0.0100	101.0	72.7	0.2	1.57	1.63	3.20	1.97	43.70	2.41	0.79
2	0.0200	175.0	126.0	0.4	2.72	1.22	3.94	3.22	46.50	2.58	1.36
3	0.0300	184.0	132.5	0.5	2.85	1.17	4.02	3.45	46.90	2.59	1.43
4	0.0400	197.0	141.8	0.7	3.05	1.11	4.16	3.75	47.30	2.63	1.53
5	0.0500	211.0	151.9	0.9	3.26	1.07	4.33	4.06	47.60	2.70	1.63
6	0.0600	224.0	161.3	1.1	3.46	1.07	4.52	4.24	47.60	2.79	1.73
7	0.0700	233.0	167.8	1.2	3.59	1.04	4.63	4.46	47.80	2.83	1.79
8	0.0800	240.0	172.8	1.4	3.69	1.02	4.71	4.61	47.90	2.87	1.85
9	0.0900	246.0	177.1	1.6	3.78	1.02	4.80	4.69	47.90	2.91	1.89
10	0.1000	250.0	180.0	1.8	3.83	1.02	4.85	4.75	47.90	2.94	1.92
11	0.2000	295.0	212.4	3.5	4.44	1.17	5.61	4.81	46.90	3.39	2.22
12	0.3000	328.0	236.2	5.3	4.85	1.31	6.16	4.70	45.90	3.73	2.42
13	0.4000	347.0	249.8	7.0	5.03	1.44	6.47	4.49	45.00	3.96	2.52
14	0.5000	374.0	269.3	8.8	5.32	1.53	6.85	4.49	44.40	4.19	2.66
15	0.6000	381.0	274.3	10.5	5.32	1.60	6.92	4.33	43.90	4.26	2.66
16	0.7000	384.0	276.5	12.3	5.25	1.68	6.94	4.12	43.30	4.31	2.63
17	0.8000	307.0	221.0	14.0	4.12	1.53	5.64	3.70	44.40	3.58	2.06
18	0.9000	222.0	159.8	15.8	2.92	1.02	3.94	3.85	47.90	2.48	1.46

Parameters for Specimen No. 2

Specimen Parameter	Initial	Saturated	Consolidated	Final
Moisture content: Moist soil+tare, gms.	1306.600			673.800
Moisture content: Dry soil+tare, gms.	1093.000			562.000
Moisture content: Tare, gms.	0.000			13.940
Moisture, %	19.5	22.0	19.9	20.4
Moist specimen weight, gms.	1306.6			
Diameter, in.	2.94	2.94	2.91	
Area, in. <sup>2</sup>	6.80	6.80	6.64	
Height, in.	5.85	5.85	5.78	
Net decrease in height, in.		0.00	0.07	
Wet Density, pcf	125.1	127.8	130.2	
Dry density, pcf	104.7	104.7	108.6	
Void ratio	0.5862	0.5862	0.5297	
Saturation, %	88.7	100.0	100.0	

Test Results for Specimen No. 2

Load ring constant = 0.72 lbs. per input unit  
 Consolidation cell pressure = 70.00 psi (10.08 ksf)  
 Consolidation back pressure = 40.00 psi (5.76 ksf)  
 Consolidation effective confining stress = 4.32 ksf  
 Strain rate, in./min. = 0.01  
 Fail. Stress = 6.96 ksf at reading no. 19

No.	Def. Dial in.	Load Dial	Load lbs.	Strain %	Deviator Stress ksf	Minor Eff. Stress ksf	Major Eff. Stress ksf	1:3 Ratio	Pore Press. psi	P ksf	Q ksf
0	0.0000	0.0	0.0	0.0	0.00	4.32	4.32	1.00	40.00	4.32	0.00
1	0.0100	127.0	91.4	0.2	1.98	3.61	5.59	1.55	44.90	4.60	0.99
2	0.0200	173.0	124.6	0.3	2.69	3.14	5.83	1.86	48.20	4.49	1.35
3	0.0300	203.0	146.2	0.5	3.15	2.78	5.93	2.13	50.70	4.36	1.58
4	0.0400	228.0	164.2	0.7	3.54	2.52	6.06	2.40	52.50	4.29	1.77
5	0.0500	253.0	182.2	0.9	3.92	2.26	6.18	2.73	54.30	4.22	1.96
6	0.0600	266.0	191.5	1.0	4.11	2.15	6.26	2.92	55.10	4.20	2.06
7	0.0700	275.0	198.0	1.2	4.24	2.02	6.26	3.10	56.00	4.14	2.12
8	0.0800	280.0	201.6	1.4	4.31	1.92	6.23	3.25	56.70	4.07	2.16
9	0.0900	284.0	204.5	1.6	4.37	1.81	6.18	3.41	57.40	4.00	2.18
10	0.1000	289.0	208.1	1.7	4.43	1.73	6.16	3.57	58.00	3.95	2.22
11	0.2000	360.0	259.2	3.5	5.43	1.44	6.87	4.77	60.00	4.15	2.71
12	0.3000	389.0	280.1	5.2	5.76	1.73	7.49	4.33	58.00	4.61	2.88
13	0.4000	422.0	303.8	6.9	6.13	1.53	7.66	5.02	59.40	4.59	3.07
14	0.5000	448.0	322.6	8.7	6.39	1.66	8.05	4.86	58.50	4.85	3.20
15	0.6000	462.0	332.6	10.4	6.46	1.79	8.25	4.62	57.60	5.02	3.23
16	0.7000	489.0	352.1	12.1	6.71	1.87	8.58	4.58	57.00	5.23	3.36
17	0.8000	508.0	365.8	13.8	6.83	1.97	8.81	4.46	56.30	5.39	3.42
18	0.9000	515.0	370.8	15.6	6.79	2.04	8.83	4.32	55.80	5.44	3.39
19	1.0000	539.0	388.1	17.3	6.96	2.09	9.05	4.33	55.50	5.57	3.48
20	1.1000	547.0	393.8	19.0	6.92	2.12	9.03	4.27	55.30	5.57	3.46
21	1.2000	560.0	403.2	20.8	6.93	2.19	9.12	4.17	54.80	5.65	3.46

**Table 1 - Test Results for Specimen No. 2**

Specimen Parameter	Initial	Saturated	Consolidated	Final
Moisture content: Moist soil+tare, gms.	1264.200			574.400
Moisture content: Dry soil+tare, gms.	1028.200			470.640
Moisture content: Tare, gms.	0.000			14.220
Moisture, %	23.0	23.8	21.4	22.7
Moist specimen weight, gms.	1264.2			
Diameter, in.	2.85	2.85	2.81	
Area, in. <sup>2</sup>	6.36	6.36	6.20	
Height, in.	6.05	6.05	5.98	
Net decrease in height, in.		0.00	0.08	
Wet Density, pcf	125.0	125.9	128.5	
Dry density, pcf	101.7	101.7	105.8	
Void ratio	0.6330	0.6330	0.5696	
Saturation, %	96.5	100.0	100.0	

**Table 2 - Test Results for Specimen No. 2**

Load ring constant = 0.72 lbs. per input unit  
 Consolidation cell pressure = 100.00 psi (14.40 ksf)  
 Consolidation back pressure = 40.00 psi (5.76 ksf)  
 Consolidation effective confining stress = 8.64 ksf  
 Strain rate, in./min. = 0.01  
 Fail. Stress = 9.32 ksf at reading no. 19

No.	Def. Dial in.	Load Dial	Load lbs.	Strain %	Deviator Stress ksf	Minor Eff. Stress ksf	Major Eff. Stress ksf	1:3 Ratio	Pore Press. psi	P ksf	Q ksf
0	0.0000	0.0	0.0	0.0	0.00	8.64	8.64	1.00	40.00	8.64	0.00
1	0.0100	131.0	94.3	0.2	2.19	7.29	9.47	1.30	49.40	8.38	1.09
2	0.0200	185.0	133.2	0.3	3.09	6.47	9.55	1.48	55.10	8.01	1.54
3	0.0300	214.0	154.1	0.5	3.56	5.92	9.48	1.60	58.90	7.70	1.78
4	0.0400	242.0	174.2	0.7	4.02	5.39	9.41	1.75	62.60	7.40	2.01
5	0.0500	262.0	188.6	0.8	4.35	5.01	9.36	1.87	65.20	7.19	2.17
6	0.0600	280.0	201.6	1.0	4.64	4.75	9.39	1.98	67.00	7.07	2.32
7	0.0700	295.0	212.4	1.2	4.88	4.54	9.41	2.08	68.50	6.98	2.44
8	0.0800	308.0	221.8	1.3	5.09	4.35	9.43	2.17	69.80	6.89	2.54
9	0.0900	323.0	232.6	1.5	5.32	4.16	9.49	2.28	71.10	6.82	2.66
10	0.1000	332.0	239.0	1.7	5.46	4.09	9.55	2.34	71.60	6.82	2.73
11	0.2000	425.0	306.0	3.3	6.87	3.72	10.59	2.85	74.20	7.15	3.44
12	0.3000	482.0	347.0	5.0	7.66	3.90	11.56	2.96	72.90	7.73	3.83
13	0.4000	529.0	380.9	6.7	8.26	3.92	12.18	3.11	72.80	8.05	4.13
14	0.5000	566.0	407.5	8.4	8.68	4.09	12.77	3.12	71.60	8.43	4.34
15	0.6000	590.0	424.8	10.0	8.88	4.32	13.20	3.06	70.00	8.76	4.44
16	0.7000	626.0	450.7	11.7	9.25	4.54	13.78	3.04	68.50	9.16	4.62
17	0.8000	642.0	462.2	13.4	9.31	4.68	13.99	2.99	67.50	9.33	4.65
18	0.9000	651.0	468.7	15.1	9.25	4.84	14.09	2.91	66.40	9.47	4.63
19	1.0000	669.0	481.7	16.7	9.32	4.98	14.30	2.87	65.40	9.64	4.66
20	1.1000	675.0	486.0	18.4	9.22	5.07	14.29	2.82	64.80	9.68	4.61
21	1.2000	690.0	496.8	20.1	9.23	5.21	14.44	2.77	63.80	9.83	4.61



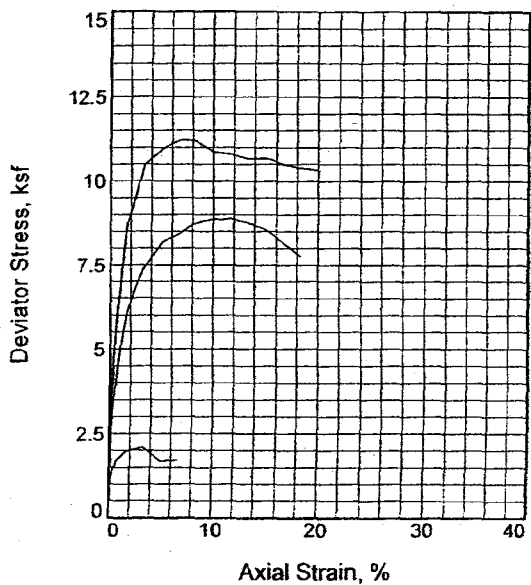
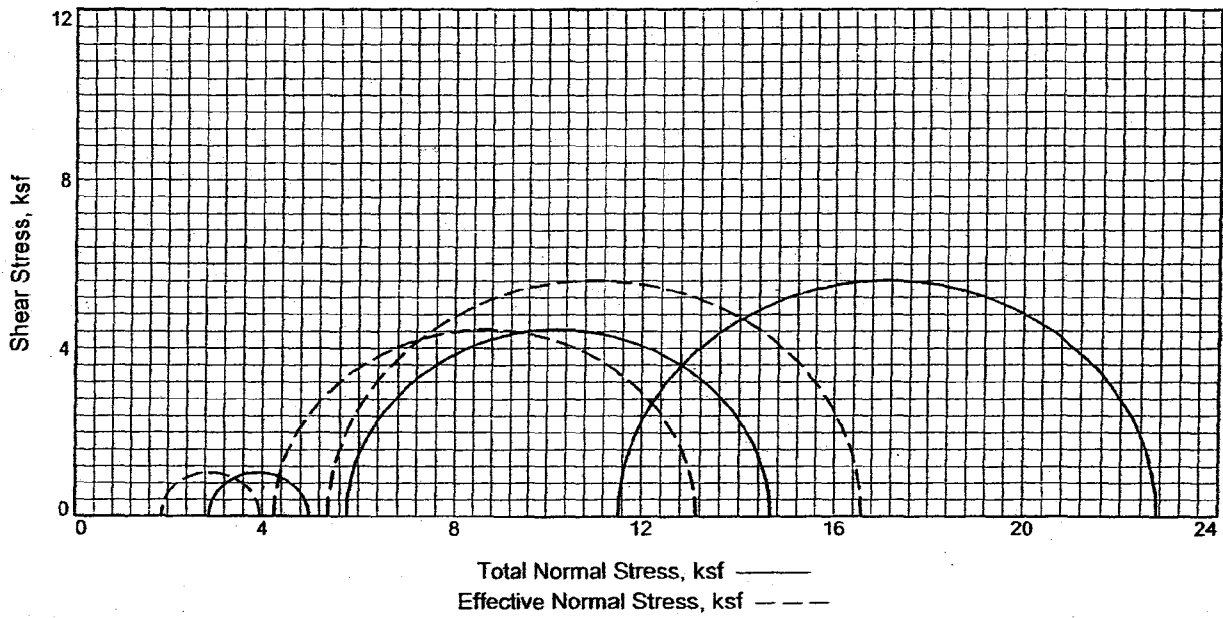

Sample No.	1	2	3	
Initial	Water Content,	32.5	30.7	27.4
	Dry Density, pcf	88.6	91.0	94.2
	Saturation,	99.9	100.0	96.6
	Void Ratio	0.8597	0.8103	0.7488
	Diameter, in.	2.84	2.85	2.84
At Test	Height, in.	6.04	6.11	6.13
	Water Content,	32.6	27.1	22.5
	Dry Density, pcf	88.6	96.1	103.3
	Saturation,	100.0	100.0	100.0
	Void Ratio	0.8597	0.7155	0.5953
Strain rate, in./min.	Diameter, in.	2.84	2.80	2.75
	Height, in.	6.04	6.01	5.95
	0.00	0.00	0.00	
	Back Pressure, ksf	2.9	2.9	2.9
	Cell Pressure, ksf	5.8	8.6	14.4
Fail. Stress, ksf	Total Pore Pr., ksf	2.1	8.9	11.2
	Ult. Stress, ksf	3.9	4.4	9.0
$\bar{\sigma}_1$ Failure, ksf	Total Pore Pr., ksf	4.0	13.1	16.6
	$\bar{\sigma}_3$ Failure, ksf	1.9	4.2	5.4

**Type of Test:**  
 CU with Pore Pressures  
**Sample Type:** undisturbed  
**Description:** Brown sandy fat clay  
 LL= 50      PL= 24      PI= 26  
 Specific Gravity= 2.64  
 Remarks: CH

**Client:** TVA  
**Project:** TVA Kingston - Proposed Gypsum Stack  
**Location:** NB-85A/B  
**Sample Number:** UD-6, 7 & 8 (CU)      **Depth:** 23'-29'  
**Proj. No.:** 3043051021      **Date:**

TRIAXIAL SHEAR TEST REPORT  
**MACTEC, INC.**

Figure \_\_\_\_\_

Tested By: Alexander

Checked By: Hamlett

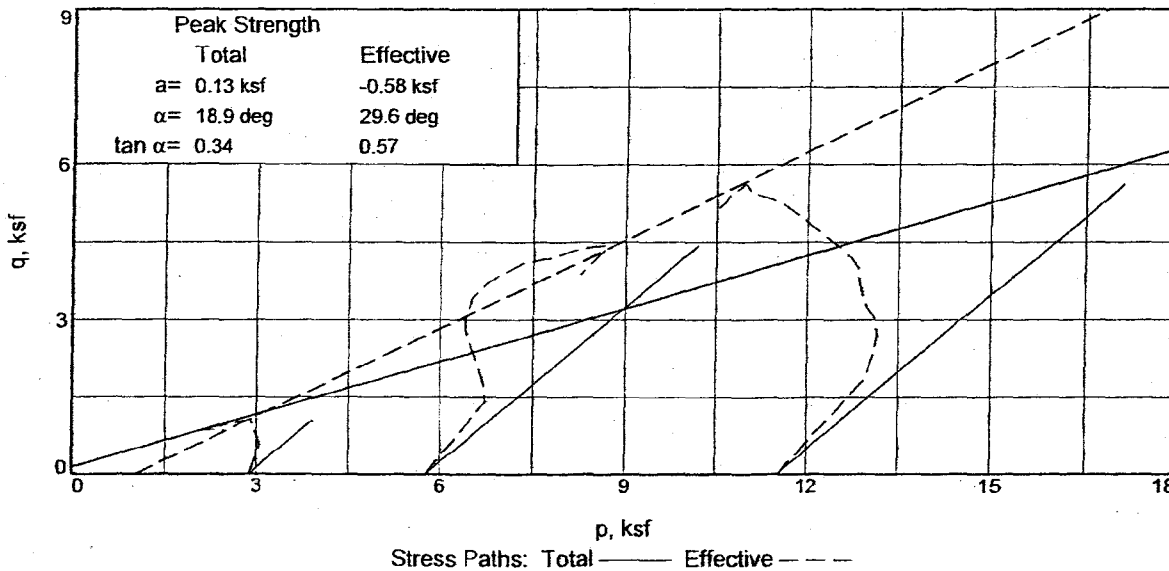
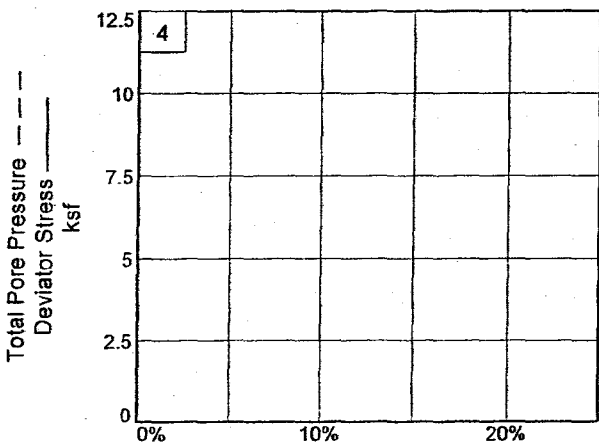
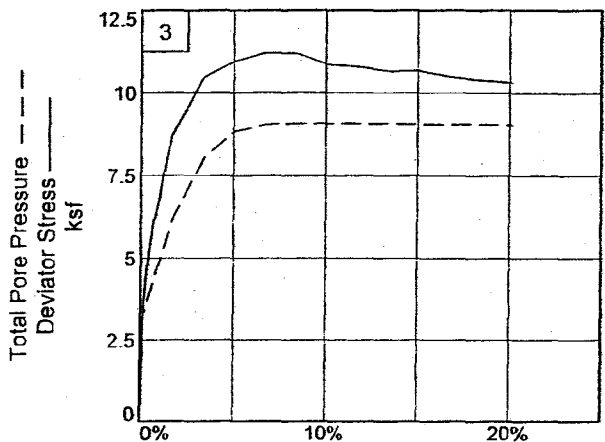
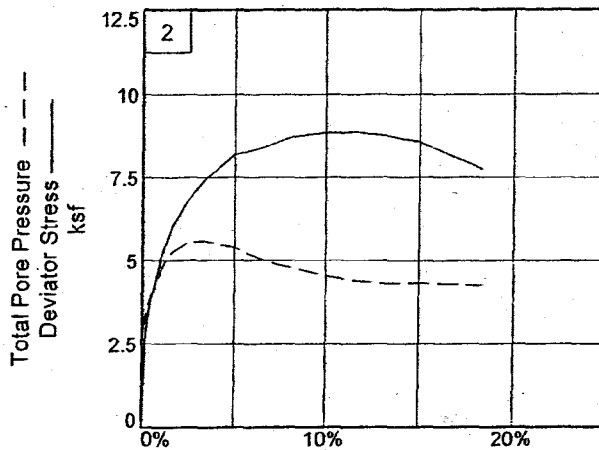
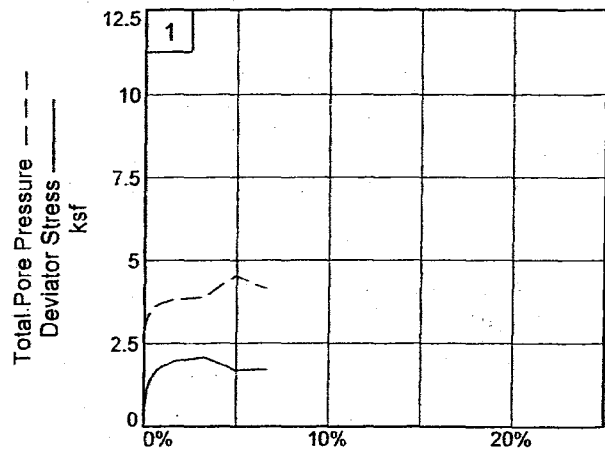

Client: TVA

Project: TVA Kingston - Proposed Gypsum Stack

Location: NB-85B

Depth: 23'-29'

Sample Number: UD-6, 7 & 8 (CU)

Project No.: 3043051021

Figure \_\_\_\_\_

**MACTEC, INC.**

Tested By: Alexander

Checked By: Hamlett



**ES/PC Results for Specimen N1011**

No.	Def. Dial in.	Load Dial	Load lbs.	Strain %	Deviator Stress ksf	Minor Eff. Stress ksf	Major Eff. Stress ksf	1:3 Ratio	Pore Press. psi	P ksf	Q ksf
0	0.0000	0.0	0.0	0.0	0.00	2.88	2.88	1.00	20.00	2.88	0.00
1	0.0100	67.0	48.2	0.2	1.10	2.51	3.60	1.44	22.60	3.05	0.55
2	0.0200	85.0	61.2	0.3	1.39	2.32	3.71	1.60	23.90	3.01	0.69
3	0.0300	96.0	69.1	0.5	1.57	2.20	3.77	1.71	24.70	2.99	0.78
4	0.0400	104.0	74.9	0.7	1.69	2.12	3.81	1.80	25.30	2.96	0.85
5	0.0500	108.0	77.8	0.8	1.76	2.07	3.83	1.85	25.60	2.95	0.88
6	0.0600	111.0	79.9	1.0	1.80	2.03	3.83	1.89	25.90	2.93	0.90
7	0.0700	114.0	82.1	1.2	1.85	2.02	3.86	1.92	26.00	2.94	0.92
8	0.0800	117.0	84.2	1.3	1.89	1.99	3.88	1.95	26.20	2.93	0.95
9	0.0900	120.0	86.4	1.5	1.94	1.96	3.90	1.99	26.40	2.93	0.97
10	0.1000	122.0	87.8	1.7	1.97	1.94	3.91	2.01	26.50	2.93	0.98
11	0.2000	132.0	95.0	3.3	2.09	1.86	3.95	2.13	27.10	2.90	1.05
12	0.3000	108.0	77.8	5.0	1.68	1.21	2.89	2.39	31.60	2.05	0.84
13	0.3500	110.0	79.2	5.8	1.70	1.45	3.15	2.17	29.90	2.30	0.85
14	0.4000	111.0	79.9	6.6	1.70	1.61	3.31	2.05	28.80	2.46	0.85

**Parameters for Specimen No. 2**

Specimen Parameter	Initial	Saturated	Consolidated	Final
Moisture content: Moist soil+tare, gms.	1216.500			669.040
Moisture content: Dry soil+tare, gms.	930.800			534.240
Moisture content: Tare, gms.	0.000			87.490
Moisture, %	30.7	30.7	27.1	30.2
Moist specimen weight, gms.	1216.5			
Diameter, in.	2.85	2.85	2.80	
Area, in. <sup>2</sup>	6.37	6.37	6.15	
Height, in.	6.11	6.11	6.01	
Net decrease in height, in.		0.00	0.11	
Wet Density, pcf	119.0	119.0	122.1	
Dry density, pcf	91.0	91.0	96.1	
Void ratio	0.8103	0.8103	0.7155	
Saturation, %	100.0	100.0	100.0	

**Test Report for Specimen No. 2**

Load ring constant = 0.72 lbs. per input unit  
 Consolidation cell pressure = 60.00 psi (8.64 ksf)  
 Consolidation back pressure = 20.00 psi (2.88 ksf)  
 Consolidation effective confining stress = 5.76 ksf  
 Strain rate, in./min. = 0.00  
 Fail. Stress = 8.88 ksf at reading no. 20

No.	Def. Dial in.	Load Dial	Load lbs.	Strain %	Deviator Stress ksf	Minor Eff. Stress ksf	Major Eff. Stress ksf	1:3 Ratio	Pore Press. psi	P ksf	Q ksf
0	0.0000	0.0	0.0	0.0	0.00	5.76	5.76	1.00	20.00	5.76	0.00
1	0.0100	168.0	121.0	0.2	2.83	5.31	8.14	1.53	23.10	6.73	1.41
2	0.0200	208.0	149.8	0.3	3.50	4.95	8.45	1.71	25.60	6.70	1.75
3	0.0300	233.0	167.8	0.5	3.91	4.69	8.61	1.83	27.40	6.65	1.96
4	0.0400	258.0	185.8	0.7	4.32	4.44	8.76	1.97	29.20	6.60	2.16
5	0.0500	281.0	202.3	0.8	4.70	4.18	8.88	2.13	31.00	6.53	2.35
6	0.0600	305.0	219.6	1.0	5.09	3.92	9.01	2.30	32.80	6.46	2.55
7	0.0700	321.0	231.1	1.2	5.35	3.74	9.10	2.43	34.00	6.42	2.68
8	0.0800	337.0	242.6	1.3	5.61	3.59	9.20	2.56	35.10	6.39	2.80
9	0.0900	352.0	253.4	1.5	5.85	3.47	9.32	2.69	35.90	6.40	2.92
10	0.1000	367.0	264.2	1.7	6.09	3.36	9.44	2.81	36.70	6.40	3.04
11	0.1500	417.0	300.2	2.5	6.86	3.08	9.94	3.23	38.60	6.51	3.43
12	0.2000	455.0	327.6	3.3	7.42	3.05	10.47	3.43	38.80	6.76	3.71
13	0.3000	510.0	367.2	5.0	8.17	3.24	11.41	3.52	37.50	7.33	4.09
14	0.4000	534.0	384.5	6.7	8.41	3.63	12.04	3.32	34.80	7.83	4.20
15	0.4500	551.0	396.7	7.5	8.60	3.77	12.37	3.28	33.80	8.07	4.30
16	0.5000	565.0	406.8	8.3	8.74	3.87	12.61	3.26	33.10	8.24	4.37
17	0.5500	574.0	413.3	9.2	8.80	3.97	12.77	3.21	32.40	8.37	4.40
18	0.6000	583.0	419.8	10.0	8.85	4.09	12.94	3.16	31.60	8.52	4.43
19	0.6500	588.0	423.4	10.8	8.85	4.18	13.02	3.12	31.00	8.60	4.42
20	0.7000	596.0	429.1	11.7	8.88	4.25	13.13	3.09	30.50	8.69	4.44
21	0.8000	599.0	431.3	13.3	8.76	4.32	13.08	3.03	30.00	8.70	4.38
22	0.9000	598.0	430.6	15.0	8.58	4.32	12.90	2.99	30.00	8.61	4.29
23	1.0000	581.0	418.3	16.7	8.17	4.35	12.52	2.88	29.80	8.43	4.09
24	1.1000	563.0	405.4	18.3	7.76	4.39	12.15	2.77	29.50	8.27	3.88

**Parameters for Specimen No. 3**

Specimen Parameter	Initial	Saturated	Consolidated	Final
Moisture content: Moist soil+tare, gms.	1221.900			617.770
Moisture content: Dry soil+tare, gms.	959.100			503.750
Moisture content: Tare, gms.	0.000			87.190
Moisture, %	27.4	28.4	22.5	27.4
Moist specimen weight, gms.	1221.9			
Diameter, in.	2.84	2.84	2.75	
Area, in. <sup>2</sup>	6.33	6.33	5.95	
Height, in.	6.13	6.13	5.95	
Net decrease in height, in.		0.00	0.18	
Wet Density, pcf	120.1	121.0	126.6	
Dry density, pcf	94.2	94.2	103.3	
Void ratio	0.7488	0.7488	0.5953	
Saturation, %	96.6	100.0	100.0	

**Test Readings for Specimen No. 3**

Load ring constant = 0.72 lbs. per input unit  
 Consolidation cell pressure = 100.00 psi (14.40 ksf)  
 Consolidation back pressure = 20.00 psi (2.88 ksf)  
 Consolidation effective confining stress = 11.52 ksf  
 Strain rate, in./min. = 0.00  
 Fail. Stress = 11.22 ksf at reading no. 13

No.	Def. Dial in.	Load Dial	Load lbs.	Strain %	Deviator Stress ksf	Minor Eff. Stress ksf	Major Eff. Stress ksf	1:3 Ratio	Pore Press. psi	P ksf	Q ksf
0	0.0000	0.0	0.0	0.0	0.00	11.52	11.52	1.00	20.00	11.52	0.00
1	0.0100	208.0	149.8	0.2	3.62	11.12	14.74	1.33	22.80	12.93	1.81
2	0.0200	270.0	194.4	0.3	4.69	10.76	15.45	1.44	25.30	13.10	2.35
3	0.0300	314.0	226.1	0.5	5.45	10.44	15.89	1.52	27.50	13.16	2.72
4	0.0400	349.0	251.3	0.7	6.04	10.11	16.15	1.60	29.80	13.13	3.02
5	0.0500	374.0	269.3	0.8	6.46	9.75	16.21	1.66	32.30	12.98	3.23
6	0.0600	402.0	289.4	1.0	6.94	9.45	16.38	1.73	34.40	12.91	3.47
7	0.0700	435.0	313.2	1.2	7.49	9.12	16.61	1.82	36.70	12.86	3.75
8	0.0800	465.0	334.8	1.3	8.00	8.84	16.84	1.90	38.60	12.84	4.00
9	0.0900	486.0	349.9	1.5	8.34	8.57	16.91	1.97	40.50	12.74	4.17
10	0.1000	509.0	366.5	1.7	8.72	8.22	16.95	2.06	42.90	12.58	4.36
11	0.2000	622.0	447.8	3.4	10.48	6.38	16.86	2.64	55.70	11.62	5.24
12	0.3000	662.0	476.6	5.0	10.96	5.57	16.53	2.97	61.30	11.05	5.48
13	0.4000	690.0	496.8	6.7	11.22	5.37	16.59	3.09	62.70	10.98	5.61
14	0.5000	702.0	505.4	8.4	11.21	5.34	16.55	3.10	62.90	10.95	5.60
15	0.6000	693.0	499.0	10.1	10.86	5.34	16.20	3.03	62.90	10.77	5.43
16	0.7000	702.0	505.4	11.8	10.80	5.34	16.14	3.02	62.90	10.74	5.40
17	0.8000	706.0	508.3	13.5	10.65	5.34	15.99	2.99	62.90	10.67	5.33
18	0.9000	721.0	519.1	15.1	10.67	5.36	16.02	2.99	62.80	10.69	5.33
19	1.0000	723.0	520.6	16.8	10.48	5.37	15.85	2.95	62.70	10.61	5.24
20	1.1000	731.0	526.3	18.5	10.38	5.37	15.76	2.93	62.70	10.56	5.19
21	1.2000	741.0	533.5	20.2	10.31	5.39	15.70	2.91	62.60	10.54	5.15

## CONSOLIDATED UNDRAINED TRIAXIAL TEST by ASTM D4767

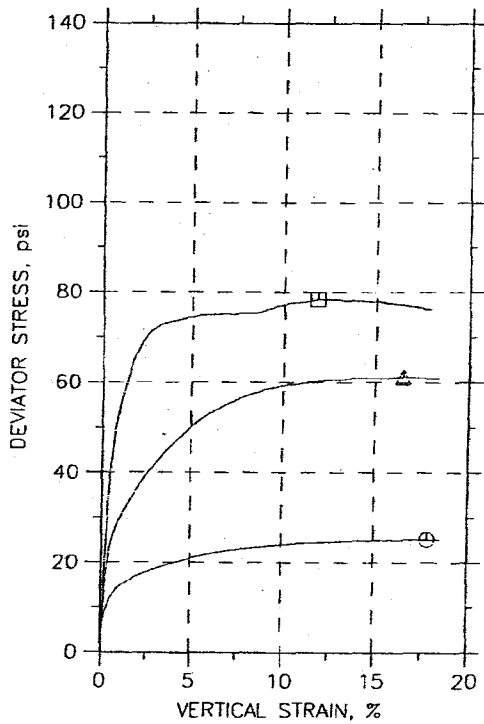
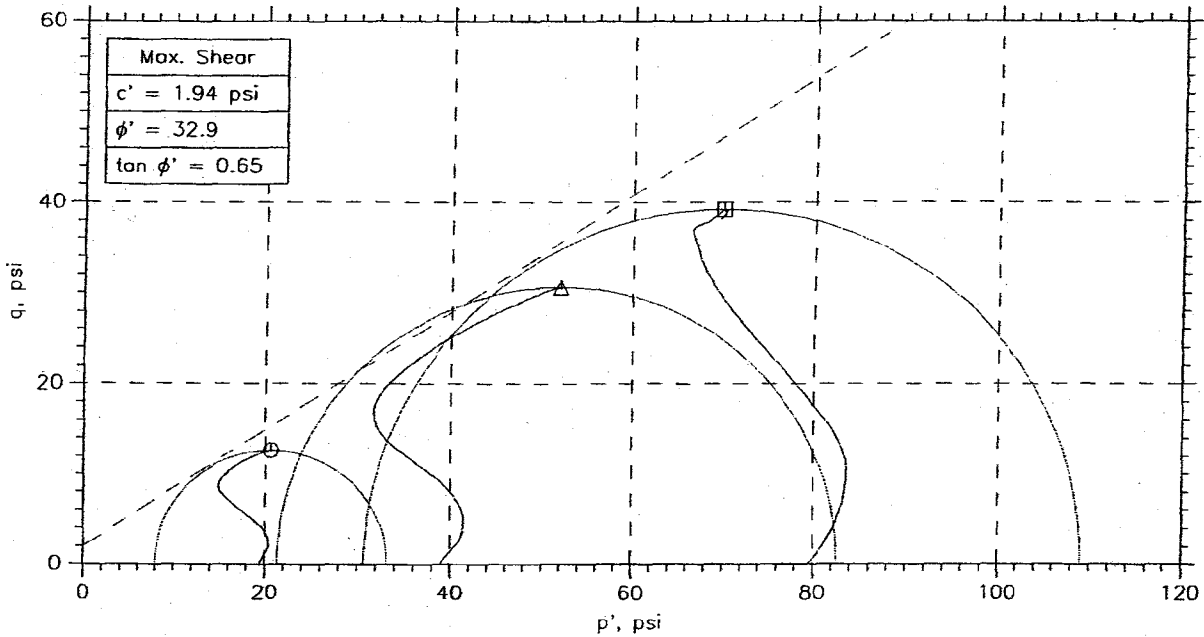

Symbol	○	△	□	
Sample No.	UD-5	UD-6	UD-5	
Test No.	13772.1	13772.2	13771.3	
Depth	28-30 ft	30-32 Ft.	28-30 ft	
Initial	Diameter, in	2.84	2.831	2.844
	Height, in	5.57	5.57	5.57
	Water Content, %	46.9	26.7	37.2
	Dry Density, pcf	76.13	98.14	85.6
	Saturation, %	103.2	98.8	102.4
Before Shear	Void Ratio	1.24	0.739	0.993
	Water Content, %	44.8	25.8	34.5
	Dry Density, pcf	76.74	100.	87.83
	Saturation*, %	100.0	100.0	100.0
	Void Ratio	1.22	0.705	0.942
	Back Press., psi	54	57.99	60
Ver. Eff. Cons. Stress, psi	20	40.01	80	
Shear Strength, psi	12.57	30.6	39.17	
Strain at Failure, %	17.8	16.5	11.8	
Strain Rate, %/min	0.022	0.022	0.022	
B-Value	0.95	0.95	0.95	
Measured Specific Gravity	2.73	2.73	2.73	
Liquid Limit	74	53	74	
Plastic Limit	36	27	36	

**GeoTesting**  
Express  
the groundwork for success

Project: TVA Kingston Gypsym Stack

Location: NB-85B

Project No.: GTX G0959

Boring No.: NB-85B

Sample Type: Shelby Tube

Description:

Remarks:

Phase calculations based on start and end of test.

\* Saturation is set to 100% for phase calculations.

Thu, 02-FEB-2006 15:26:40

TVA-00021837

## CONSOLIDATED UNDRAINED TRIAXIAL TEST by ASTM D4767

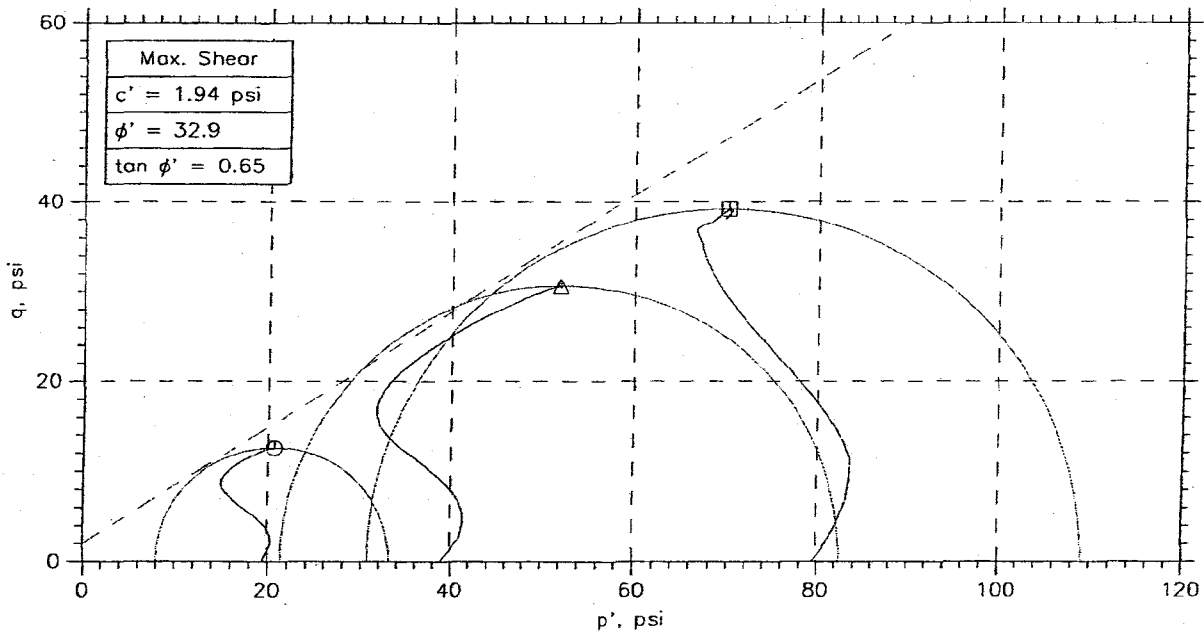
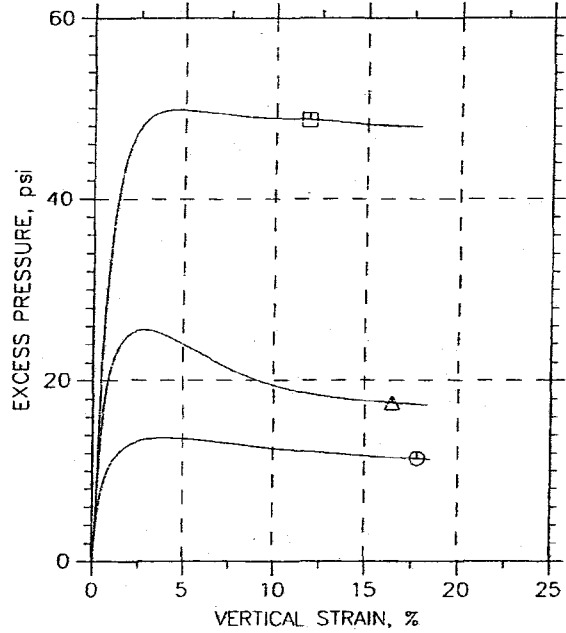
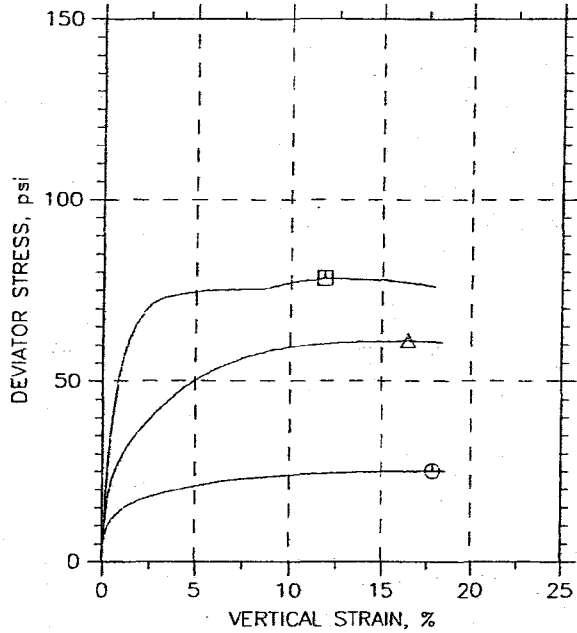

Sample No.	Test No.	Depth	Tested By	Test Date	Checked By	Check Date	Test File
⊙	UD-5	13772.1	28-30 ft	JW	12/9/05	HJ	13771.1_1057.dot
△	UD-6	13772.2	30-32 Ft.	JW	12/9/05	HJ	13772.2_2054.dot
□	UD-5	13771.3	28-30 ft	JW	12/9/05	HJ	13771.3_1062.dot

**GeoTesting  
express**  
the groundwork for success

Project: TVA Kingston Gypsum Storage	Location: NB-85B	Project No.: GTX G0959
Boring No.: NB-85B	Sample Type: Shelby Tube	
Description:		
Remarks:		



## CONSOLIDATED UNDRAINED TRIAXIAL TEST by ASTM D4767

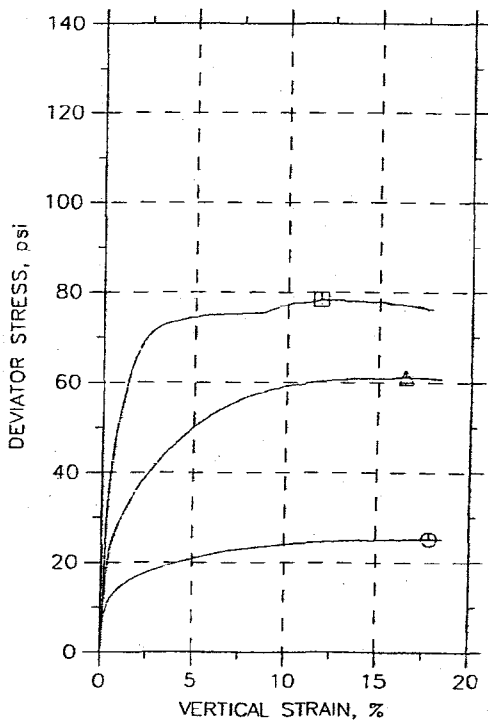
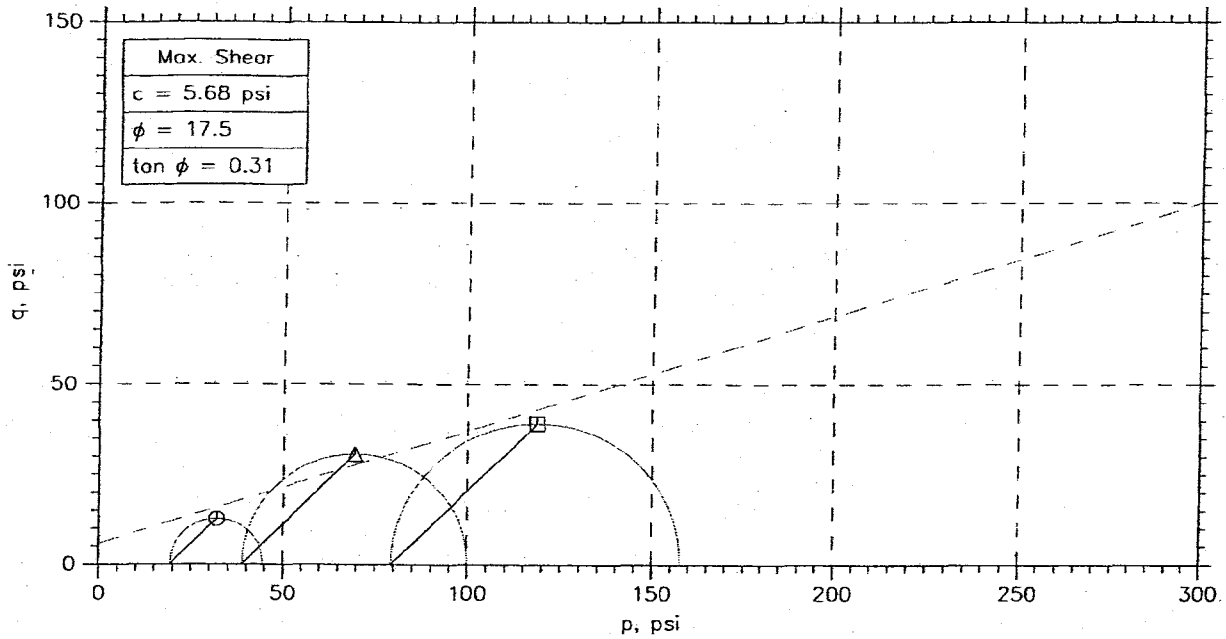

Symbol	⊙	△	□	
Sample No.	UD-5	UD-6	UD-5	
Test No.	13772.1	13772.2	13771.3	
Depth	28-30 ft	30-32 Ft.	28-30 ft	
Initial	Diameter, in	2.84	2.831	2.844
	Height, in	5.57	5.57	5.57
	Water Content, %	46.9	26.7	37.2
	Dry Density, pcf	76.13	98.14	85.6
	Saturation, %	103.2	98.8	102.4
Before Shear	Void Ratio	1.24	0.739	0.993
	Water Content, %	44.8	25.8	34.5
	Dry Density, pcf	76.74	100.	87.83
	Saturation*, %	100.0	100.0	100.0
	Void Ratio	1.22	0.705	0.942
Back Press., psi	54	57.99	60	
Ver. Eff. Cons. Stress, psi	20	40.01	80	
Shear Strength, psi	12.57	30.6	39.17	
Strain at Failure, %	17.8	16.5	11.8	
Strain Rate, %/min	0.022	0.022	0.022	
B-Value	0.95	0.95	0.95	
Measured Specific Gravity	2.73	2.73	2.73	
Liquid Limit	74	53	74	
Plastic Limit	36	27	36	

**GeoTesting**  
express  
the groundwork for success

Project: TVA Kingston Gypsum Stack

Location: NB-85B

Project No.: GTX G0959

Boring No.: NB-85B

Sample Type: Shelby Tube

Description:

Remarks:

Phase calculations based on start and end of test.

\* Saturation is set to 100% for phase calculations.

Thu, 02-FEB-2006 15:27:10

TVA-00021839

# CONSOLIDATED UNDRAINED TRIAXIAL TEST by ASTM D4767

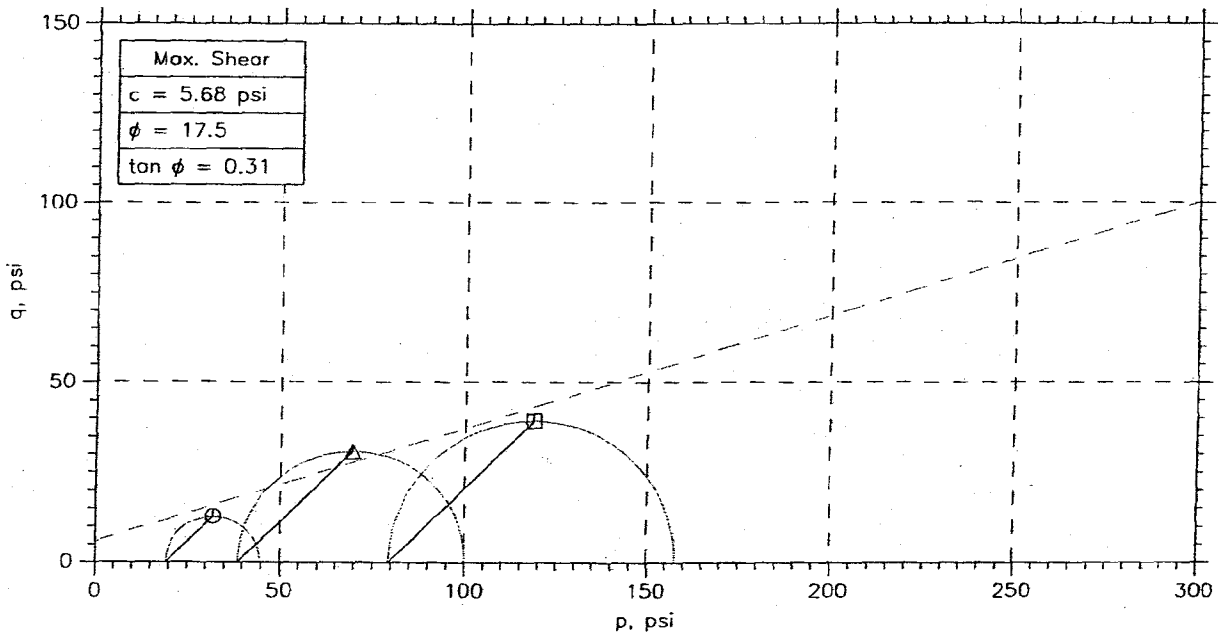
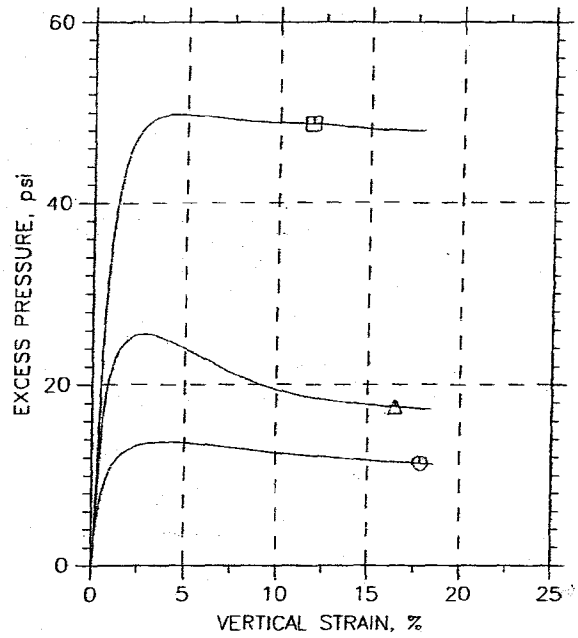
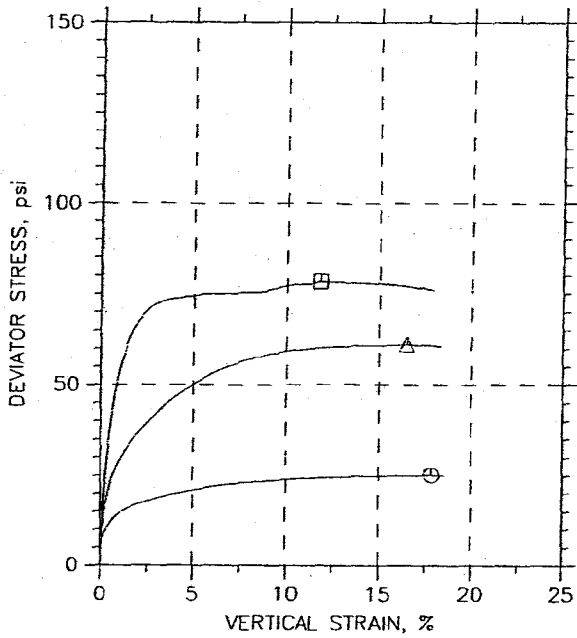

	Sample No.	Test No.	Depth	Tested By	Test Date	Checked By	Check Date	Test File
○	UD-5	13772.1	28-30 ft	JW	12/9/05	HJ		13771.1_1057.dat
△	UD-6	13772.2	30-32 Ft.	JW	12/9/05	HJ		13772.2_2054.dat
□	UD-5	13771.3	28-30 ft	JW	12/9/05	HJ		13771.3_1062.dat

 the groundwork for success	Project: TVA Kingston Gypsum Storage Location: NB-85B		Project No.: GTX G0959
	Boring No.: NB-85B		Sample Type: Shelby Tube
	Description:		
	Remarks:		

**PERMEABILITY TEST RESULTS**

**PERMEABILITY TEST RESULTS**

**TVA Kingston - Gypsum Disposal  
 MACTEC Project No.  
 3043-05-1064-01**

**Summary of Laboratory Testing for Hydraulic Conductivity**

Boring	Sample	Depth (ft)	Moisture (%)	Dry Unit wt (pcf)	Hydraulic Conductivity (cm/sec)
K-11	UD	12-14	22.9	102.4	$9.1 \times 10^{-7}$
K-12	UD	12-14	24.3	96.1	$7.6 \times 10^{-6}$
K-13	UD	12-14	29.9	87.4	$1.6 \times 10^{-6}$
K-14	UD	12-14	29.4	94.2	$1.7 \times 10^{-8}$
K-15A	UD	12-13	37.3	80.3	$2.2 \times 10^{-6}$
K-16	Bulk	10-15	24.6	95.7	$2.6 \times 10^{-8}$
K-17	Bulk	10-15	31.7	86.6	$1.3 \times 10^{-8}$
K-18	Bulk	10-15	31.6	87.1	$2.7 \times 10^{-8}$

Note: Bulk soil samples were remolded to approximately 95% of their respective standard Proctor maximum dry densities and 2% over optimum moisture content.

*CJA*