

DRAFT

Trackwork Estimate for Kingston Spur

Track	(including Ballast & Ties)	<u>Quantity</u>	<u>Units</u>	<u>Unit Price</u>	<u>Extension</u>
	Jointed	300	TF	\$85.00	\$ 25,500.00
	CW	25,813.29	TF	\$91.00	\$ 2,349,009.39
	GuardRails	1260	TF	\$30.00	\$ 37,800.00
Turnouts (New)		7	EA	\$22,525.00	\$ 157,675.00
Relocated T.O.'s		2	EA	\$5,000.00	\$ 10,000.00
Crossings (surface)					
	Swan Pond Circle (North)(RubberMat)	1	LS	\$15,000.00	\$ 15,000.00
	Swan Pond Circle (South)(RubberMat)	1	LS	\$15,000.00	\$ 15,000.00
	Kingston Plant Entrance (Timber)	1	LS	\$30,000.00	\$ 30,000.00
	Plant Road at Harriman	1	LS	\$10,000.00	\$ 10,000.00
	Private Crossings	6	EA	\$1,000.00	\$ 6,000.00
	Signals Swan Pond (N)	1	EA	\$150,000.00	\$ 150,000.00
	Signals Swan Pond (S)	1	EA	\$100,000.00	\$ 100,000.00
	Signs	8	EA	\$300.00	\$ 2,400.00
Removals					
	Track in Harriman Yard	1126	TF	\$20.00	\$ 22,520.00
Other Items					
	Flaggers in NS Yard				\$ 5,000.00
	Mobilization				\$ 15,000.00
	Demob				\$ 15,000.00
				Total	\$ 2,965,904.39

j:fossil/site/kif spur estimate.xls

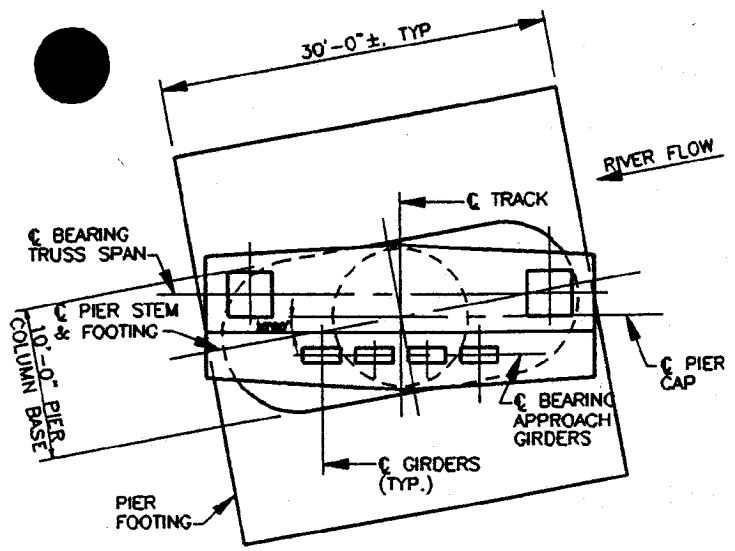

PLAN - CENTER SPAN PIERS

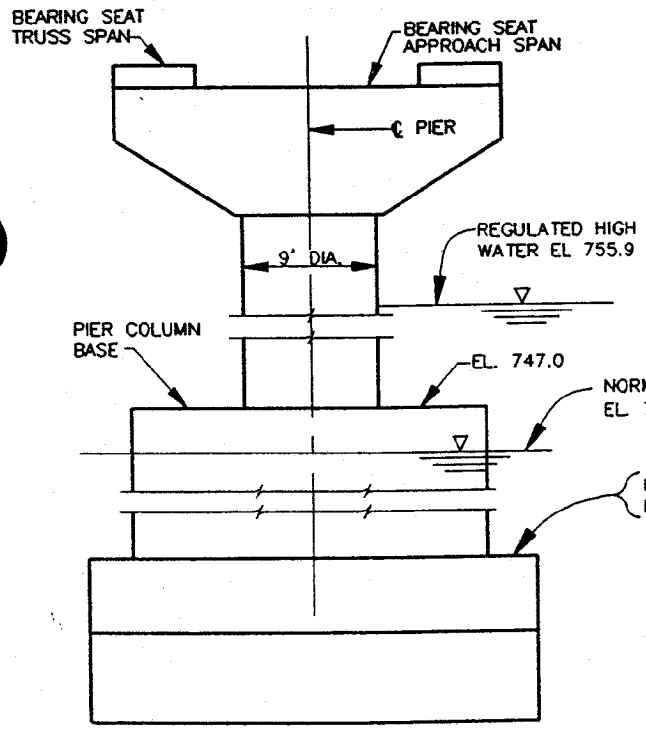

ELEVATION - CENTER SPAN PIERS

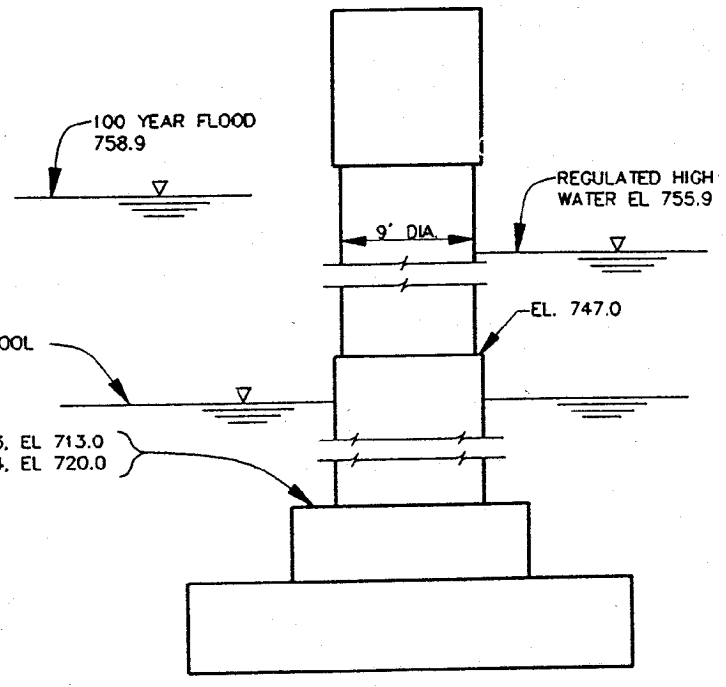

END VIEW - CENTER SPAN PIERS

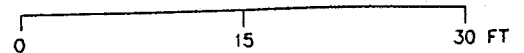

- NOTES:
1. VERTICAL DATUM - NGVD 29
 2. NAVIGATION CHANNEL BOTTOM GRADE IS EL 724.0.

PROPOSED BRIDGE
 over EMORY RIVER
 at ROANE COUNTY, TENNESSEE
 counties ROANE COUNTY, TENN.
 application by TENN. VALLEY AUTHORITY
 sheet 4 of 4 date 10-2-97

REVISION DATE 12-15-97

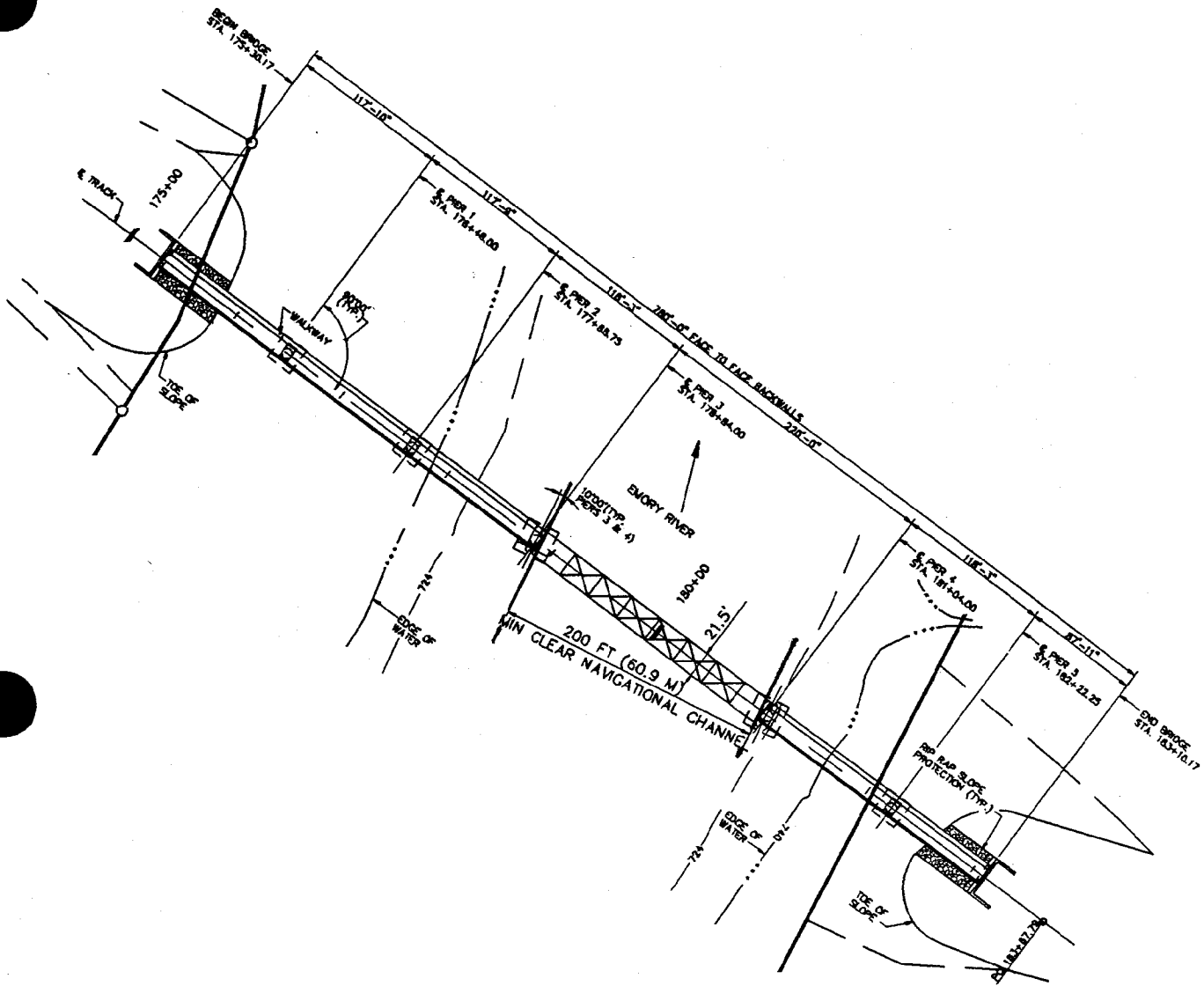

PLAN

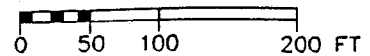

NOTE:
 NAVIGATION CHANNEL BOTTOM GRADE
 IS EL 724.0.

PROPOSED BRIDGE

over EMORY RIVER
 at ROANE COUNTY, TENNESSEE
 counties ROANE COUNTY, TENN.
 application by TENN. VALLEY AUTHORITY
 sheet 2 of 4 date 10-2-97

REVISED 12-15-97

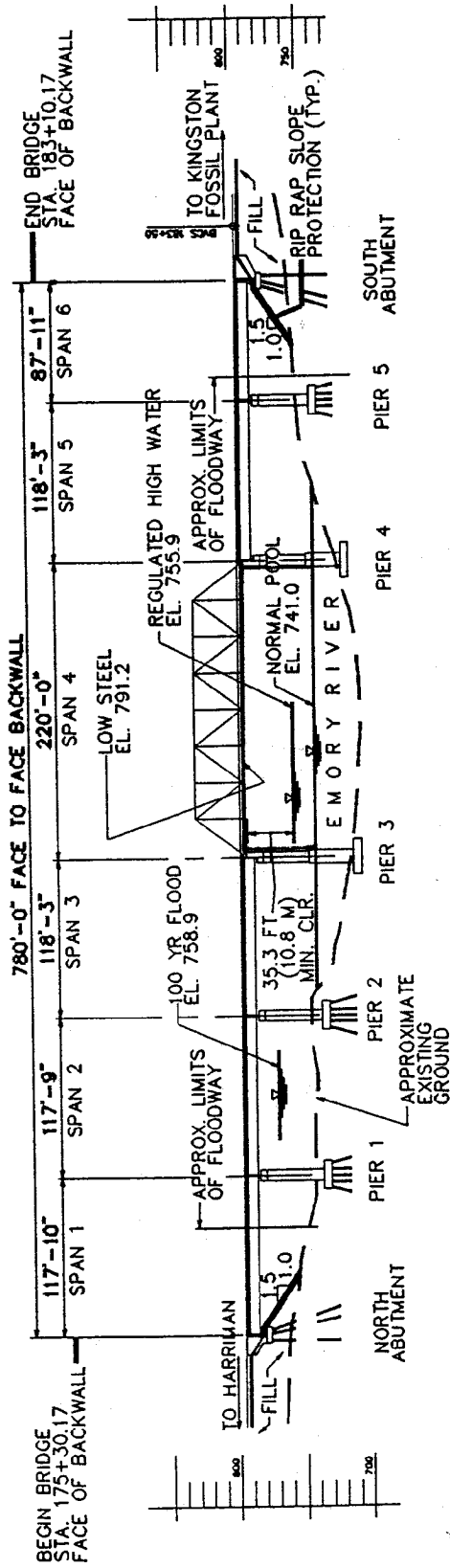

ELEVATION
SHOWN ALONG & TRACK

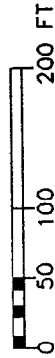

NOTE:
VERTICAL DATUM - NGVD 29

PROPOSED BRIDGE

over EMORY RIVER
 at ROANE COUNTY, TENNESSEE
 counties ROANE COUNTY, TENN.
 application by TENN. VALLEY AUTHORITY
 sheet 3 of 4 date 10-2-97
 REVISED 12-15-97