

VS OFFICE

Wednesday 08/05/92 04:27 pm

To: Ralph G Johnson C PE08 BR 2B
 From: Yvonne R Hosler Security: Limited
 Subject: KIF BackupSewagePumpStati Date Received: 08/05/92

8/5/92

Ralph Johnson:

KINGSTON FOSSIL PLANT - BACKUP SEWAGE PUMP STATION

Please pursue the engineering and drawings necessary to allow installation. Drawings are needed for State approval.

Charge time to 68XX-544045-X4500C-J2020.

Let me know if your cost will exceed \$6K.

Robert L. Bruce (x7226)
 Project Manager
 BR 3D-C

(by Yvonne Hosler)

RECEIVED
 FOSSIL ENGRG
 SERVICES

08 05 '92

Referred	H	Info	Comments
RGJ		✓	
RAB			
KWB	✓		
LED			
FWJ			
WLP			
JWP			
EBR			
PHF			

July 28, 1992

Kenneth W. Burnette, MR 3D-C

KINGSTON FOSSIL PLANT - BACKUP SEWAGE PUMPS

As we discussed on the telephone, I am forwarding you all field specifications and sketches for your use in preparing PE approved drawings and specifications to be submitted to the State.

Once these drawings and specifications are completed, please mail to R.L.Pope at Kingston Fossil Plant.

Call me at 224-1293 if you have any questions.

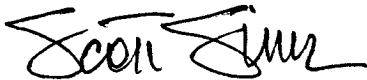

Scott Sims
Manager, Modification Projects
Modification Services
Kingston Fossil Plant

cc: R.L. Pope

→ Thursday, Aug. 13th
SCOPE 4 MANHOLE EST. FOR PHASE II DESIGN
DURATION / SCHEDULE
PRESTIGE NUMBER
GET LOCATION DRWG.
SCOPE
COORDINATE WITH OTHERS
DESIGN SUMP BOX

Project Authorization No. 923064A
Date APRIL 16, 1992

Agreement between Eastern Zone MOD SVS and G.UB.MK
Requesting Organization Performing Organization

Location: KINGSTON FOSSIL PLANT Unit(s): YARD

Description of work to be performed: INSTALL BACK UP SEWAGE PUMPS
AS PER ATTACHED RFP
(IF APPROVED, CONSTRUCTION WILL BE PERFORMED UNDER SAME PA NUMBER)

Estimated costs:
ESTIMATE COST : ESTIMATE COST NOT TO EXCEED \$4000
LABOR MHRS : (ACTUAL EXPENSE TO BE FURNISHED
Labor COST : WITH ESTIMATE)
MATERIAL/TOOLS:
EQUIPMENT :
MISC :
TOTAL :

Projected commencement and completion dates: START 5/4/92
COMPLETE 6/12/92

Account Number: Requesting Organization Performing Organization
Principal Contact: 70A5-544045-X45A00Z-22020

Name: SCOTT SIMS JERRY MOUNTS
Signature: Julie C. Graves for
Title: FOSSIL MODIFICATION MGR
Address: KINGSTON FOSSIL PLANT
Telephone No.: 9-1-224-1293

Plant Approval: Name: VERBALLY APPROVED LARRY ROBERTS
Signature: _____
Date: 4-16-92

Organization Budget Officer: Name: _____

Approved By: Name: Lawrence D. Chapman
Title: Eastern Zone Manager
Signature: Julie C. Graves for
Date: 4/17/92

Distribution of copies:
1 Julie C. Graves, SMW 1A-K
2 Rob Ivey, SMW 1A-K
3 Plant Manager (LARRY ROBERTS)
4 Project Manager (BOB BRUCE)
5 Carol Lawson, LP 2E-C
6 John May, SMW 1A-K
7 SCOTT SIMS, KINGSTON

**MODIFICATION SERVICES
REQUEST FOR PROPOSAL (RFP)**

Title INSTALL BACKUP SEWAGE PUMPS PCN No. _____
 Location KINGSTON RFP No. 923064A
 Unit(s) YARD Date APRIL 16, 1992
 Request for proposal between MOO. SVS and G.UB.MK
 Requesting Organization Performing Organization

Proposal needed by: APRIL 24, 1992

Description of work to be performed:

Scope: INSTALL BACKUP SEWAGE PUMPS AS PER ATTACHED SCOPE.

Overall Schedule: Start MAY 4, 1992
 Finish JUNE 12, 1992

Specification and Drawings:

No _____ Yes (See Attachment PROVIDED)

Special or Project Specific Facilities Available:

No Yes _____ (See Attachment _____)

List of Accounts: (See Attachment PROVIDED)

Special Technical Requirements or Special Reports and Documentation

Required: No _____ Yes (See Attachment PROVIDED)

List of Types and Numbers of Personnel Required:

No Yes _____ (See Attachment _____)

Other (Describe) _____

No Yes _____ (See Attachment _____)

Proposal to include the following:

<input checked="" type="checkbox"/>	Yes	_____	No	Detailed Estimate
<input checked="" type="checkbox"/>	Yes	_____	No	Detailed Project Schedule
_____	Yes	<input checked="" type="checkbox"/>	No	Staffing Plan
<input checked="" type="checkbox"/>	Yes	_____	No	Listing of Proposed Subcontracts and Qualification and Experience Information
_____	Yes	<input checked="" type="checkbox"/>	No	Special Labor Relations Information
<input checked="" type="checkbox"/>	Yes	_____	No	General Listing of Small Tools, Consumable Materials, Heavy Equipment Required
_____	Yes	<input checked="" type="checkbox"/>	No	Other (Describe) _____

	<u>Requesting Organization</u>	<u>Performing Organization</u>
Principal Contact:		
Name	<u>SCOTT SIMS</u>	<u>JERRY MOUNTS</u>
Signature	<u>JULIE C. GRAVES</u>	_____
Title	<u>FOSSIL MODIFICATION MGR</u>	_____
Address	<u>KINGSTON FOSSIL PLANT</u>	_____
Telephone No.	<u>224-1293 OR 224-1277</u>	_____

PROJECT DESCRIPTION

Provide and install two new sewage pumps, a cast in place concrete lift station, electrical feed and controls for the new pumps and connecting piping.

SCOPE DETAILS

A cast in place reinforced concrete lift station shall be constructed approximately 10 feet south of the existing chlorination building as shown on TVA drawing 17W400. The slab shall be 8 inches thick with No. 4 bars 12" on center both ways. The interior dimensions for the lift station shall be 6 feet x 6 feet x 9 feet 3 inches deep. The walls are to be 8" thick with No. 4 bars 12 inches on center both ways. The lift station shall be covered with a painted 1/2 inch thick steel plate. Hinged doors shall be provided in the plate for access and pump removal. Each door shall be sized such that total weight of door does not exceed 60 lbs. Hinges and handles shall be included. The concrete lift station shall be watertight. A retaining wall similar to the one for Coal Yard sump (18W250-1 & 2) shall be provided.

Two new submersible pumps shall be installed in the new lift station. Each pump will be rated at 90 GPM at 105 TDH. The pumps will be of the recessed impeller type. Each pump shall be provided with a frame for easy removal of the pumps without making any piping disconnections. The frame shall be provided by the pump vendor. New 4" PVC piping shall be provided for the pump discharge. Each pump shall be provided with a pressure gage and root valve, a check valve and an isolation valve. An isolation valve shall be provided in the existing sewage ejector line. The 6" combined PVC discharge for the new pumps shall tie back the existing sewage ejector discharge. An 8" PVC line shall be used for draining the old chlorinator building sump to new lift station. A 4" vent shall be installed between the two sumps. The 2 lines shall be offset to allow for settling. Each line shall be sealed in the station and old chlorinator building sump. A sliderail system along with guiderails shall be furnished for each pump. All valves shall be provided with valve boxes.

Power to the pumps will be from feeder board in crusher building. A new 100 amp breaker shall be installed in bottom of panel 4.3-1#2 AWG copper wire shall be run from panel to existing coal yard sump pump via conduit PLC-2220. A weather tight junction box shall be installed at coal yard sump pumps with feed to new sewage pumps. A NEMA 3 or 3R weather tight duplex control panel shall be installed at the pumps. Fusible disconnects shall be provided for each pump. The pumps shall have automatic on and off controls. Levels shall be set for duty pump on, standby on, high level alarm and low level off. Local annunciation (orange light for pump on & red light for high level alarm) shall be provided locally. Tie onto existing ground wire in area. See 25W800 for existing layout.

A 1-1/2" raw water line shall be routed at the new lift station for washing out of station. The 1-1/2" line shall be SCH 80 PVC and shall terminate at grade in a valve box. The 1-1/2" line shall be fitted with a female hose connection.

Pump drawings, curves, O & M manuals and motor data shall be furnished by partner to TVA on the equipment.

The system shall be electrically checked out and put into service. The area around the new pumps shall be graded, leveled and grass planted to agree with surrounding area.

REFERENCE DRAWINGS

1. 18W250-1 & 2, Yard Misc Concrete Sumps (later)
2. 17W400, 401, 402, 403, 404, Yard Sewage
3. 25W800, Yard Conduit and Grounding
4. 17W412-2, Yard Chemical Treatment Pond and Coal Pile Drainage
5. 45C800 PLC-112 480 Volt Cable Schedule

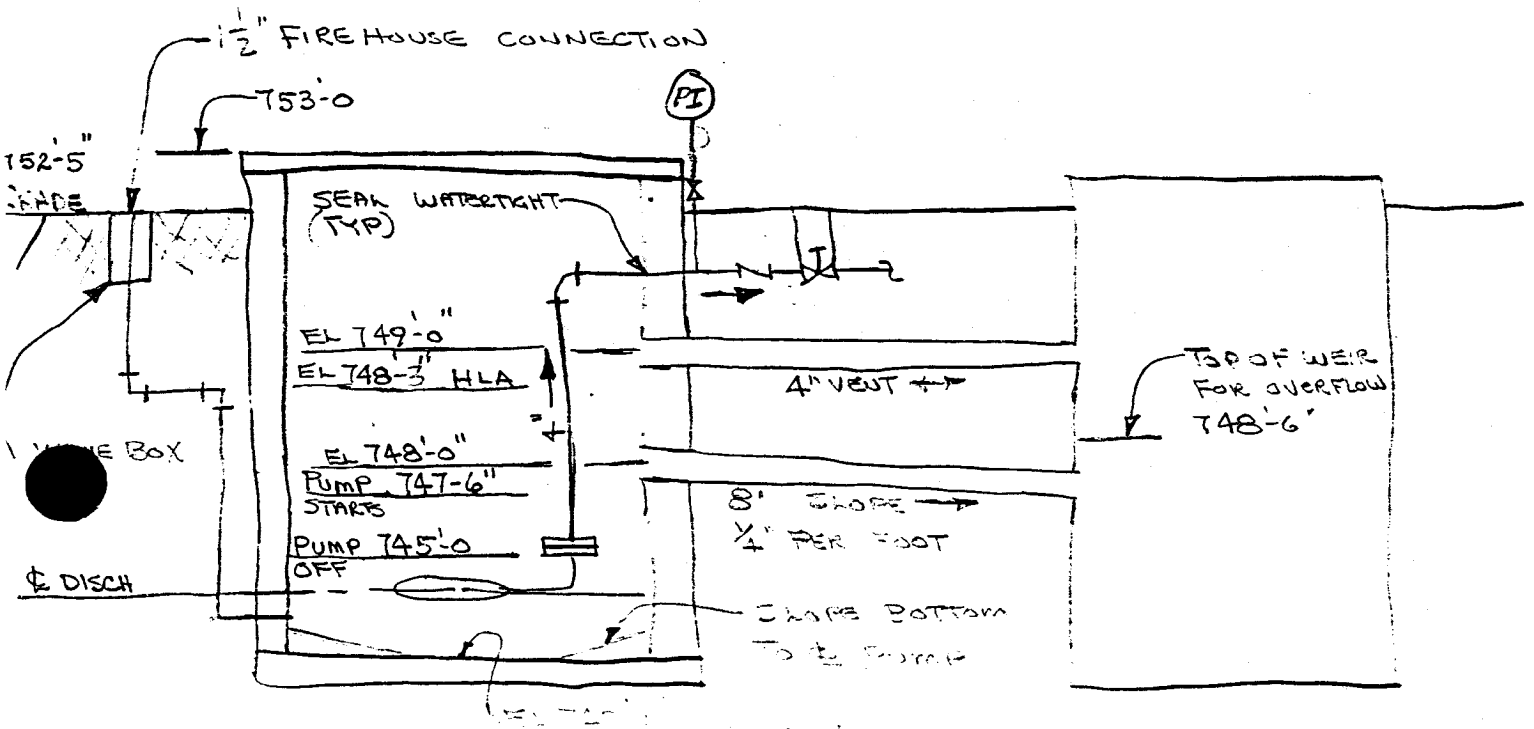
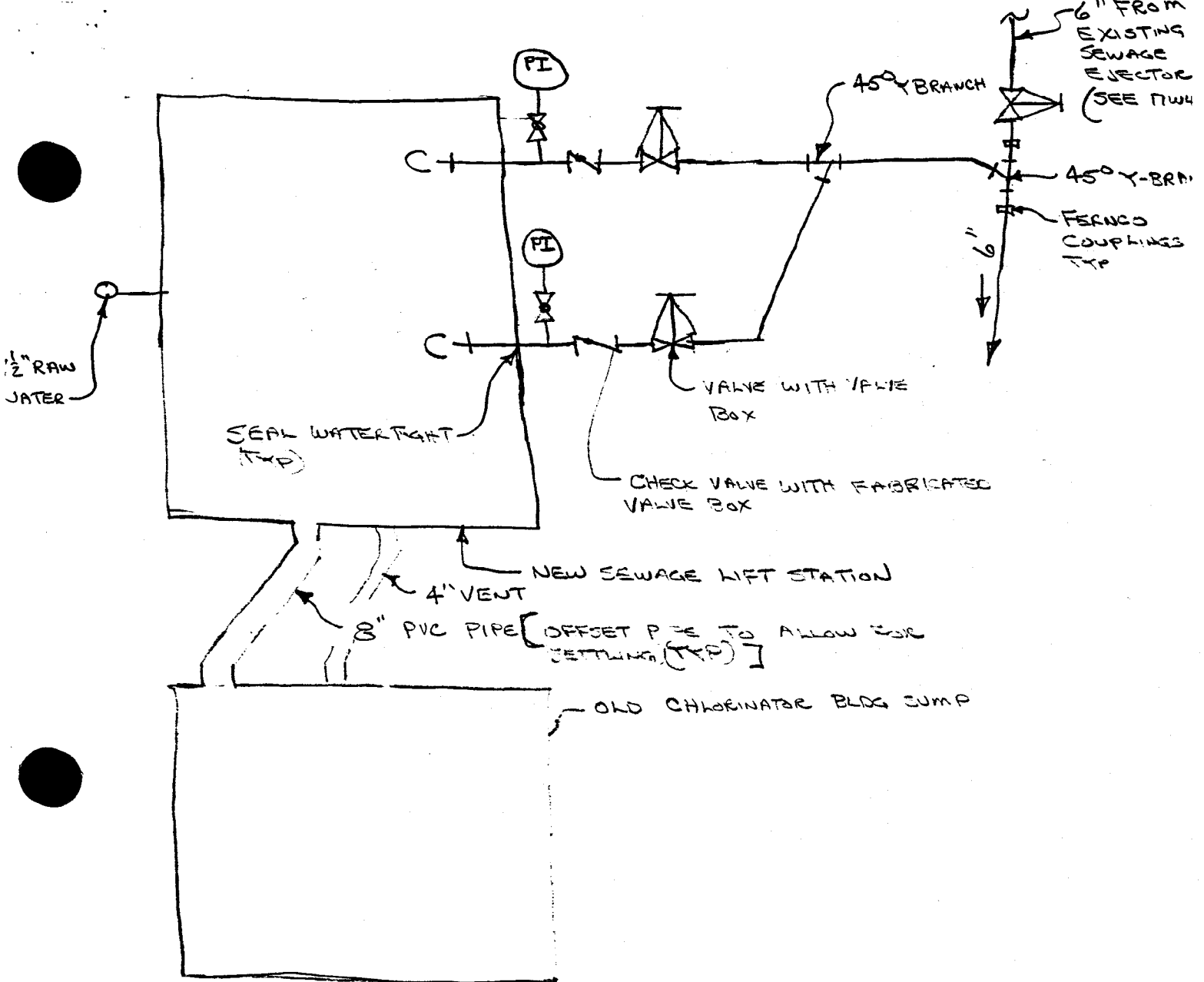

HP (1)	RPM (2)	NEMA DESIGN CODE	LOCKED ROTOR CODE	WGT	FRAME	FULL LOAD AMP		FULL LOAD		COIL RESISTANCE		CABLE SIZE	
						230V	460V	PF	EFF	230V	460V	230V	460
.5	1775	A	R	165	140TY	4.0	2.0	53.5	47.0	4.67	18.8	14	14
.75	1750	A	P	165	140TY	4.2	2.1	63.4	54.9	4.67	18.8	14	14
1	1735	B	L	165	140TY	5.0	2.5	71.6	54.5	4.67	18.8	14	14
1.5	1730	B	K	165	140TY	6.0	3.0	74.5	63.8	3.398	13.59	14	14
2	1735	B	K	165	140TY	7.2	3.6	76.0	68.9	2.30	9.2	14	14
3	1725	B	H	165	140TY	10.4	5.2	77.6	71.5	1.62	6.48	14	14
5	1735	B	H	200	180TY	14.8	7.4	81.3	76.0	.95	3.8	12	14
7.5	1740	B	H	200	180TY	21.0	10.5	80.6	83.8	.545	2.18	10	14
10	1755	B	H	335	210TY	27.0	13.5	80.5	86.2	.368	1.471	8	12
15	1755	B	G	335	210TY	42.0	21.0	77.8	86.0	.213	.853	8	10
20	1750	B	G	335	210TY	56.0	28.0	80.3	84.4	.178	.714	6	8
25	1750	B	G	445	250TY	66.0	33.0	84.1	84.8	.140	.5618	4	8
30	1750	B	G	445	250TY	78.0	39.0	85.4	84.1	.1125	.45	2	8
40	1745	B	F	445	250TY	104.0	52.0	84.6	86.7	.084	.336	2	6
50	1770	B	F	1150	320TY	126.0	63.0	83.0	90.1	.042	.168	1/0	4
60	1765	B	F	1150	320TY	154.6	77.3	81.2	90.0	.0388	.155	2/0	2
75	1770	B	F	1150	320TY	NA	92.0	82.9	91.4	NA	.1104	NA	2
100	1775	B	G	1500	360TY	NA	120.0	83.2	91.3	NA	.0809	NA	1
125	1770	B	F	1500	360TY	NA	153.0	83.2	92.0	NA	.0511	NA	2/0

(1) MOTOR RATINGS ABOVE 60 HP ARE NOT AVAILABLE AT VOLTAGES BELOW 460 VOLTS.

(2) FOUR POLE MOTORS ARE 1750 RPM.

- 208 VOLT AMPERAGE MULTIPLY 230 VOLT AMPERAGE BY 1.15.

- CONTROL CABLE FOR ALL MOTORS IS .485+/-0.025 INCHES DIAMETER, CONDUCTOR SIZE 18/5.

- CONSULT FACTORY FOR POWER CABLE LENGTHS GREATER THAN 95 FEET.

- WHEN MOTORS ARE ORDERED AT 460 VOLT CONNECTION ONLY, MOTORS WILL NOT BE RECONNECTABLE TO 230 VOLT.

PROPOSAL BY

D&F Distributors, Inc.

PUMPS OF ALL TYPES • WATER & SEWAGE TREATMENT CONTROLS AND EQUIPMENT
LOW AND HIGH VACUUM PUMPS • AIR MOTORS • ROTARY COMPRESSORS • BLOWERS • EJECTORS

1144 INDY COURT
EVANSVILLE, IN 47711
(812) 867-2441
FAX (812) 867-6822

2606 EUGENIA AVENUE
NASHVILLE, TN 37211
(615) 259-9090
FAX (615) 259-9095

8727 COMMERCE PARK PL., SUITE 1
INDIANAPOLIS, IN 46268
(317) 876-9208
FAX (317) 879-8648

6309 ULRICH AVENUE
LOUISVILLE, KY 40219
(502) 968-0107
FAX (502) 968-0538

April 3, 1991

Tennessee Valley Authority

Attn: Garland Corder
Subject: Kingston Springs Sewage Pumps/Revision #1
Conditions: 90GPM @ 105'TDH / pH = 7

Dear Mr. Corder,

I am pleased to quote the following for your consideration. Should the conditions be different than about please contact me

Qty (2) ESSCO submersible pump, size 4x12, complete with 20HP 460/3/60 1750rpm motor, frame 210TY with 100% recessed impeller, cast iron construction, dual mechanical seals, warrick seal failure indicator in panel, koppers 200 coating
.....\$ \$4947.00 each pump

Qty (1) ESSCO Sliderrail system for ESSCO pumps, Duplex design to include pump discharge flanges, baseplate/ discharge elbows and brackets. (TVA to provide 1&1/4" inch pipe sch #40 as guide rails) system designed for two pumps
.....\$ 1572.00 each
(two required)

Qty (1) Duplex Control Panel for above ESSCO pumps, with NEMA weathertight enclosure, high water alarm, alarm light, seal failure indicator, 4 float switches, and float brcket
..... \$ 1882.00 each

Please call with your questions.

FOB: Collect from Factory
Terms: Net 30 Days
Delivery: 4 to 6 weeks

Sincerely,
Mark P. Sharp
Mark P. Sharp
Sales Engineer

1-800-264-0355
800-264-0355

ORDER ACCEPTANCE CONDITIONS

1. Shipping Instructions

All material on this quotation must be released for shipment at one time to one destination. We reserve the right to make additional charges for partial releases.

2. Acceptance of this Proposal

This proposal is subject to your acceptance within thirty (30) days and to the subsequent approval by an Executive Officer of our company. Unless otherwise specified on our invoice terms will be net thirty days. A service charge of 1½% per month will be charged on all accounts 31 days or over from date of invoice 18% per annum plus attorney fees and collection costs.

3. Changes and Modifications

No amendments or modifications of this agreement shall be binding on either party unless specified in writing and signed by both. Changes in specifications for goods or material covered by this proposal can be made only with our written consent.

4. Delays and Liability

We shall not be responsible for delay caused by strikes, lockouts, inability to procure materials, allocation or restriction on deliveries of materials to be furnished by D & F Distributors, Inc. whether imposed by law; regulation; or any action of our suppliers; fire, accident, or causes beyond our control. Delays in delivery of the products covered by this proposal occasioned by reason of your request (e.g., changes in design or specifications) or your act, or omission, shall or may cause correspondingly extended delivery of subject product. Under these conditions, our obligation to meet a specific shipping date is cancelled.

5. Taxes and Duties

The above prices do not include any Federal, State, Local or Use Tax and if such taxes apply, they should be paid direct.

Cancellation

Cancellation or delay in releasing for shipment of products described on your request will be accepted only upon terms that will indemnify us against loss. In the event of any cancellation by you, prior to completion of this order, you shall pay us whatever charges may be accrued against D & F Distributors, Inc. by its actions in arranging for procurement of same.

7. Title and Ownership

Title to the goods and material covered by this proposal shall pass to you as and when the same are delivered by us to carrier, and we shall not be responsible for any loss, damage or destruction thereof occurring after such delivery.

8. Returned Goods

Written permission must be obtained before returning any material to us or our supplier. Material returned for credit will be subject to factory inspection. All material must be shipped with transportation charges prepaid. A restocking charge of 10% will be assessed for goods returned.

Products which are made to special order are not returnable.

9. WARRANTIES

The only warranties are the express warranties of the manufacturer(s). D & F DISTRIBUTORS MAKES NO OTHER WARRANTY OF ANY KIND WHATEVER, EXPRESSED OR IMPLIED, AND ALL IMPLIED WARRANTIES OF MERCHANTABILITY AND FITNESS FOR A PARTICULAR PURPOSE ARE HEREBY DISCLAIMED BY D & F DISTRIBUTORS AND EXCLUDED FROM THIS AGREEMENT.

DAMAGES

UNDER NO CIRCUMSTANCES WILL D & F DISTRIBUTORS BE LIABLE FOR ANY SPECIAL, INDIRECT, INCIDENTAL, OR CONSEQUENTIAL DAMAGES, EXPENSES, LOSSES OR DELAYS HOWSOEVER CAUSED.

ESSCO

SUBMERSIBLE PUMPS WITH NON-CLOG OR SEMI-OPEN IMPELLER

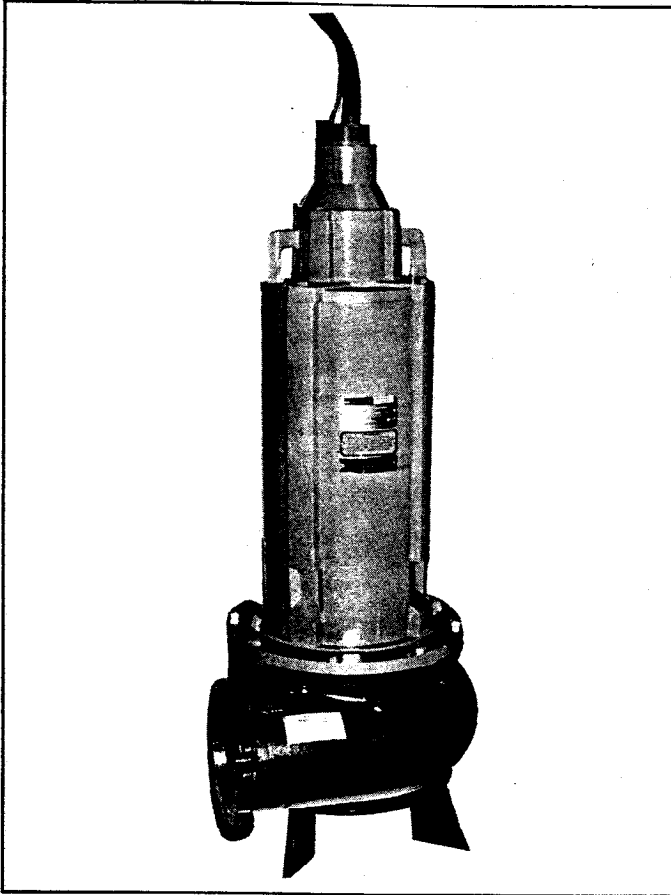

ESSCO submersible non-clog pumps are designed to provide the maximum pump efficiencies while maintaining the optimum in equipment life. ESSCO designs maximum flexibility into every unit, such as special materials, special coatings, special mechanical seals and many other options.

VOLUTE: Each ESSCO volute is designed with maximum life in mind. ESSCO provides extra material in high wear areas as well as special designs to handle heavy grit slurries.

IMPELLER: All ESSCO non-clog impellers are designed with smooth water passages. Each impeller is inspected for irregular surfaces, then statically, and on larger units, dynamically balanced.

COOL AGIVENT: Each ESSCO submersible pump includes a Cool Agivent apparatus which is for venting pump cases and cooling external surface of the motor. This patented device will allow a more shallow wet well design, as well as keep the motor cool when not submerged. All ESSCO submersible pumps are capable of running dry continuously. (Consult factory for specific applications.)

MOTOR: Reliance U.L. listed for Class 1, Div. 1, Group D, hazardous location, complete with a moisture detector and thermal protection. Heavy duty thrust bearings and dual seals give added protection and on special request high temperature or abrasion resistant seals are available.

SIZES AVAILABLE: 3" through 12" discharge.

WEAR RINGS: All ESSCO non-clog pumps are available with wear rings. Wear ring materials include cast iron, bronze, stainless steel and on special request, hardened wear rings. Other materials are available. (Consult factory with specific details.)

SPECIAL MATERIALS: ESSCO submersible pumps are available in materials other than cast iron. Special materials include 316 S.S., bronze and high chromium iron (Brinnell 550-650 hardness). Other materials are available on special requests

All ESSCO Pumps are Cast, Manufactured, Assembled and Tested in the U.S.A.

ENGINEERS SALES-SERVICE CO., INC.



4935 TELEGRAPH ROAD
P.O. BOX 7036
LOS ANGELES, CA 90022-0736
(213) 261-2181
FAX (213) 261-1523

FORM SP-002

DISTRIBUTED BY:

D & F DISTRIBUTORS, INC.

2606 Eugenia Avenue
Nashville, TN 37211
(615) 259-9090

D & F DISTRIBUTORS, INC.
2606 Eugenia Avenue
Nashville, TN 37211
(615) 259-9090

**SPECIFICATIONS FOR ESSCO SUBMERSIBLE VORTEX PUMPS
CAST IRON CONSTRUCTION**

GENERAL:

Pump shall be furnished as follows:

Size 4 " heavy duty submersible pump which shall include a submersible motor, cast iron volute, cast iron impeller, carbon ceramic lower mechanical seal and stainless steel hardware.

PUMPING CONDITIONS:

90 gallons per minute at 105 ft. total dynamic head with motor load not exceeding 20 HP rating.

PUMP CASING:

Pump casing shall be constructed of class 30 cast iron . All internal case clearances shall be equal to discharge diameter so that large diameter solids or long stringy materials will pass through the pump with the greatest handling efficiency.

Where the pump motor flange comes in contact with the volute there shall be an adapter plate or the volute shall have an indexed register to insure an accurate fit.

IMPELLER:

The impeller shall be 100% recessed, shrouded, flat design and shall be mounted in such a manner as to allow solids which enter the suction opening to leave the pump with minimal impeller contact. The solids or fluids being pumped shall not have to enter impeller in order to discharge.

Cupped impellers, curved impellers, or impellers that protrude into the volute in a manner that impedes the flow of pipe sized solids are not acceptable.

The impeller shall be attached to the shaft by a stainless steel bolt, stainless steel washer, stainless steel key, and be mechanically locked to insure that the impeller bolt will not back out if unit is operated backwards. Pumps over 30 HP shall have a cad. plated grade 8 bolt in lieu of a 316 S.S. impeller bolt.

PUMP SUPPORT STAND:

When used the pump support stand shall be heavy duty capable of supporting the full weight of the pump and motor.

EXTERNAL HARDWARE:

All external shall be made of 300 series stainless steel.

GENERAL - MOTOR:

The pump motor shall be a 3 phase, 20HP, 220/440 volts, 1750 RPM, AC, U.L. listed Reliance submersible motor, manufactured by Reliance Electric Co., 24701 Euclid Ave., Cleveland, Ohio 44117 and shall not exceed 20 HP rating at any of the above rated conditions. No exceptions.

MOTOR SHAFT:

The motor shaft shall be one piece 416 stainless steel. Shaft extending through both bearings with proper length to connect directly to pump impeller.

The bearings shall be prelubricated at the factory and designed for B10-life of 35,000 hours.

The shaft extension bearings shall be locked to prevent shaft movement and to take high thrust loads.

MOTOR ENCLOSURES:

Motor enclosures shall be cast iron, water-tight and shall be sealed by the use of "O" rings and shall have rabbit joints with a large overlap, or there shall be furnished an adapter plate to accomplish an accurate fit equal to an indexed register fit.

Electrical cable leads shall be 25 feet in length and joined to motor enclosure by use of an epoxy mold in the motor end bracket.

Lifting eyes shall be cast into the motor housing and shall be of adequate strength to lift the entire pump and motor assembly.

The motor shall contain dual independent mechanical seals with one operating in a oil bath.

MOTOR SEALS:

A carbon against ceramic lower mechanical seal shall be installed prior to pump shipment. A written verification shall be provided prior to shipment of the pump unit. The seal elastomers shall be Buna-N and the spring shall be 316 S.S.

Two moisture sensing probes shall be used to detect any influx of conductive liquid past the outer seal and provide ample warning of first seal failure.

A carbon against ceramic inner mechanical seal shall be installed prior to pump shipment. A written verification shall be provided prior to shipment of the pump unit. The seal elastomers shall be Buna-N and the spring shall be 316 S.S.

MOTOR:

The motor nameplate horsepower rating shall not be exceeded by the brake horsepower requirements of the pump for the specified head and GPM condition.

The motor shall contain special Class "B" insulation with Class "F" materials. Insulation shall be rated for continuous duty in free air at rated horsepower.

Automatic reset, normally closed thermal overloads, shall be installed in adjacent phases of the motor winding to provide the overheating protection.

The motor shall be designed for a Class I, Division I, Group D, hazardous location as defined by the National Electrical Code.

Motor nameplate shall be made of stainless steel.

FASTENERS:

All fasteners and impeller spacer shall be stainless steel.

CERTIFICATION:

Pumps and motors must be certified by testing. See attached certification requirements. The written certification report must be supplied prior to shipment of pumps to user.

PUMP INFORMATION:

Prior to shipment of pumps from factory, eight (8) copies of information listed below shall be submitted to:

Pump information to be submitted:

1. Pump cross section with parts list.
2. Pump shop detail drawings.
3. Certified performance data and test reports.
(See attached certification requirements.)
4. Instructions for erection or installation, operation and maintenance.

CERTIFICATION REQUIREMENTS

PUMP TEST:

The pump manufacturer shall perform the following inspections and tests on each pump before shipment from factory:

- a.) Impeller, motor rating and electrical connections shall first be checked for compliance to the customer's purchase order.
- b.) A motor and cable insulation test for moisture content or insulation defects shall be made.

- c.) Prior to submergence, the pump shall be run dry to establish correct rotation and mechanical integrity.
- d.) The pump shall be run for 30 minutes submerged, a minimum of six (6) ft. under water.
- e.) After operational test d.), the insulation test b.) are to be performed again.
- f.) Certification that pump units meet required pumping conditions.

A written report stating the forgoing steps have been done will be supplied with each pump prior to the time of shipment.

The pump cable end will be sealed with a high quality protective covering to make it impervious to moisture or water seepage prior to electrical installation.

PUMP WARRANTY:

The pump manufacturer shall warrant the units being supplied to the owner against defects in workmanship and material for a period of five (5) years or 10,000 hours under normal use, operation and service. The warranty shall be in printed form and apply to all similar units.

C:\WS2000\88
March 20, 1989

JOB #:

SIZE	A	B	C	D	E	F	G	H	I	J	K	L	M	N	O
3	14.75	8.125	10	7	17	14	18	15	13.25	4.5	14.5	5.75	17.625	11	14
4	14.75	8.125	10	7	17	14	18	15	13.25	4.5	14.5	5.75	17.625	11	14
6	17.625	9.25	12	9	19	16	20	17	15.375	5.5	15.5	5.75	18.625	11	16

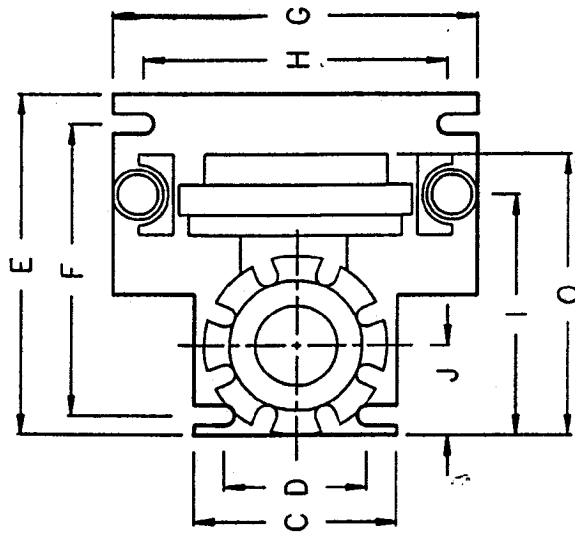
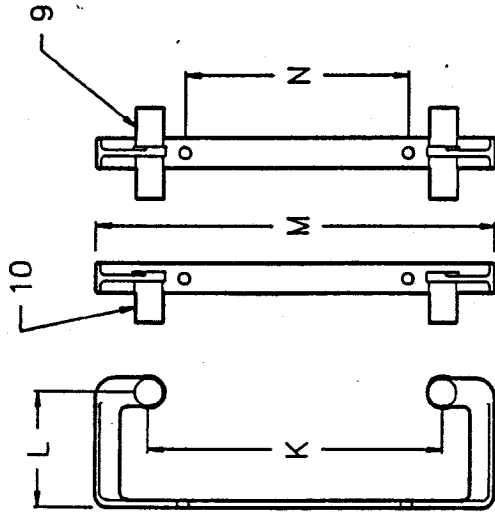
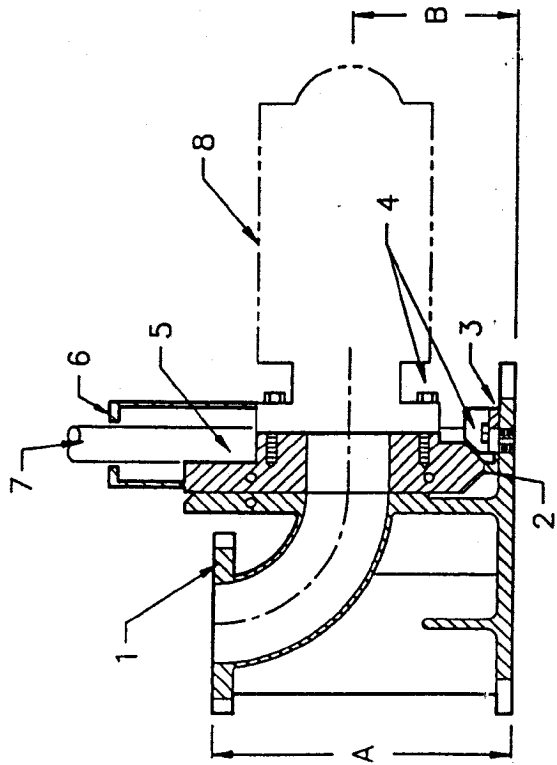

ITEM DESCRIPTION	MATERIAL
1 ELBOW	CAST IRON
2 RAIL SOCKET	316 STAINLESS STEEL
3 KICKER	CAST IRON
4 CAP SCREW	304 STAINLESS STEEL
5 SLIDING FACE	BRONZE
6 RAIL PIPE GUIDE	BRONZE
7 GUIDE PIPE (BY OTHERS)	
8 PUMP REFERENCE	
9 INTERMEDIATE GUIDE BRACKET (OPTIONAL)	304 OR 316 STAINLESS STEEL
10 TOP GUIDE BRACKET	304 OR 316 STAINLESS STEEL

ALL DIMENSIONS ARE IN INCHES

ES&CO PUMPS

DATE: 5/17/89
 FILE NAME: SLDDIM3
 DRAWN BY: BRAD J. MANN
 CHECKED BY: J.I.
 REV. DATE: 1/24/89

DIMENSIONS FOR
 SLIDE RAIL ELBOW

JOB #:

JOB #: _____ SR #: _____
 CUSTOMER NAME: _____
 CERTIFIED BY: _____
 DATE: _____

140TY=28.76
 180TY=29.26
 210TY=34.37
 250TY=40.75
 320TY=45.44
 360TY=59.37

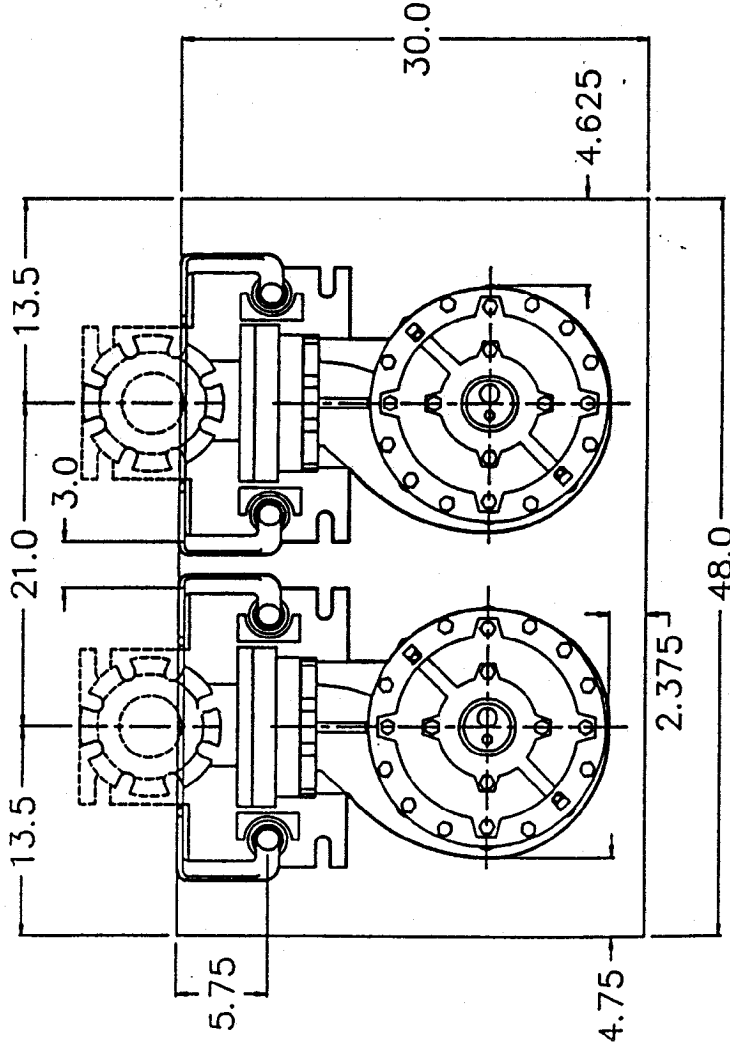
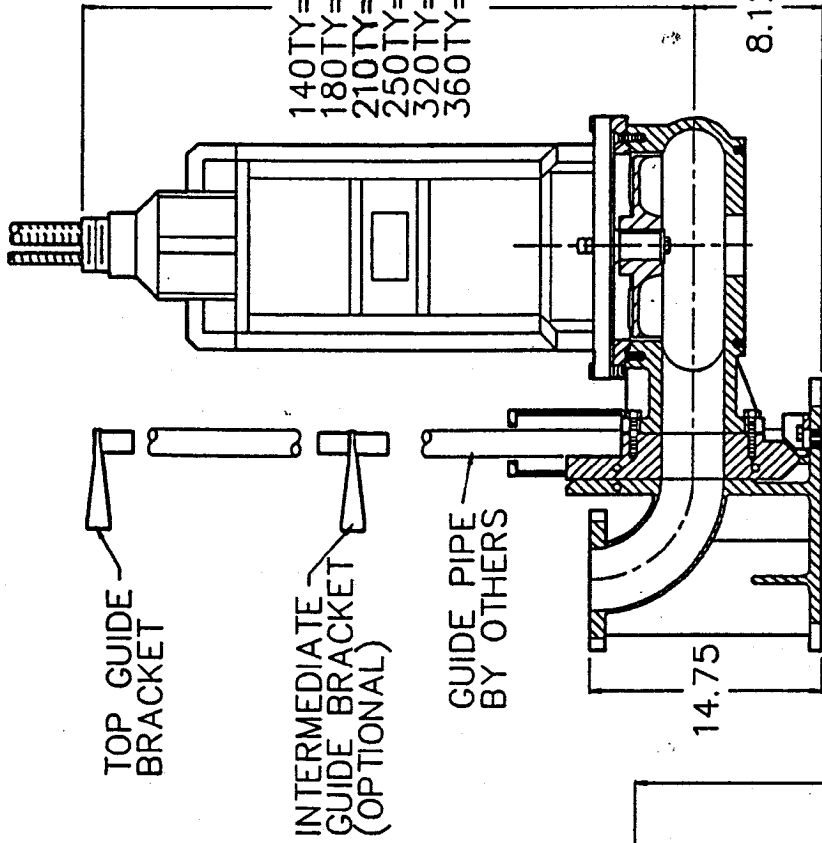

(1) NOT FOR CONSTRUCTION UNLESS CERTIFIED.
 NOTES:

ALL DIMENSIONS ARE IN INCHES

DATE:	1/23/89
FILE NAME:	412PIT
DRAWN BY:	BRAD J. MANN
CHECKED BY:	J.I.
REV. DATE:	4/17/90

ES&CO PUMPS

HATCH COVER
 LAYOUT FOR
 4 X 12 VORTEX
 CENTERLINE PUMP

SIZE	A	B	C	D	E	F	G	H	J	K	L
3X8	8.3	*	3.4	5.5	6.8	9.6	5.8	-	7.3	11.8	7.8
4X12	11.6	*	4	7.8	8.8	9.7	4.5	6.5	7.5	18	9
4X16	12.9	*	4	7.8	9.6	12.1	4.5	7.5	10.4	19.5	9
6X12	15.4	*	6	9.5	9.5	10.8	6	6.3	9.3	19.5	11
6X8X17	19.1	*	8	12.5	13	16	5.5	8.5	10.5	28	11

MOTOR FRAME SIZE					
140TY	180TY	210TY	250TY	320TY	360TY
B 23.9	24.4	30.1	35.5	37.8	43.3

NOTES:

1. ALL DIMENSIONS ARE IN INCHES.
2. NOT FOR CONSTRUCTION UNLESS CERTIFIED.
3. DIMENSIONS +/- .05 INCH.
4. FLANGES HAVE 125# C.I. DRILLING.

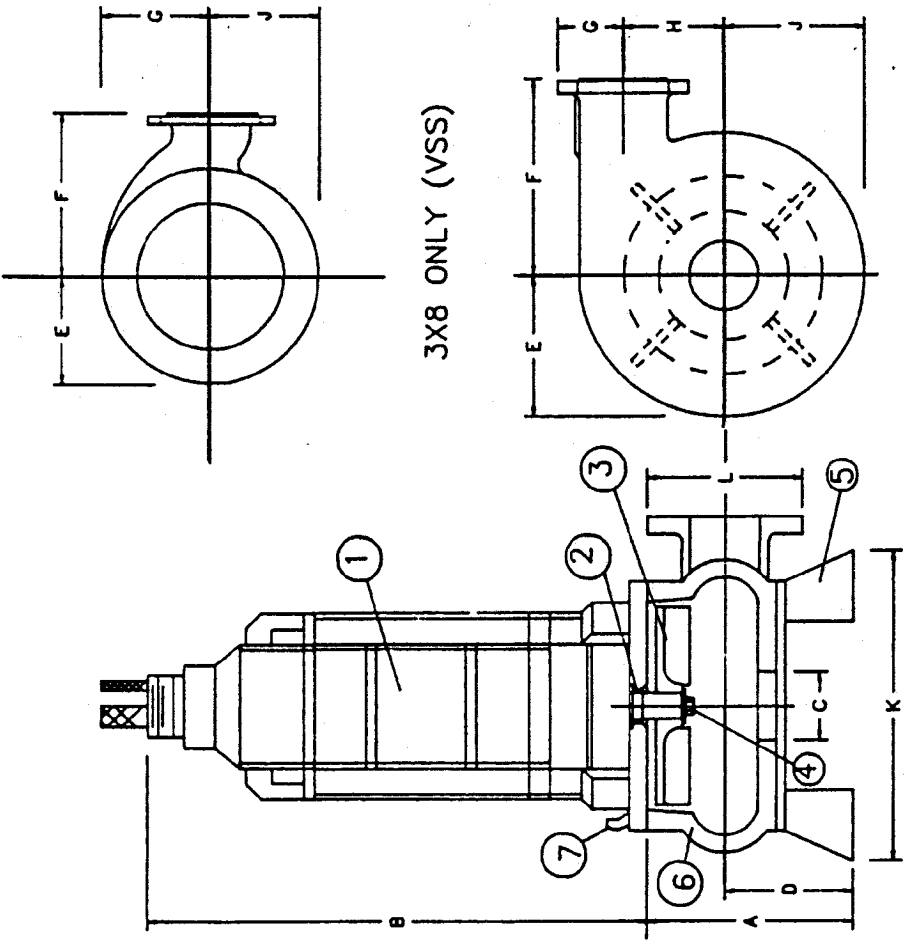

PARTS LIST

1	U.L. LISTED MOTOR
2	STAINLESS STEEL SPACER
3	CAST IRON CLOCKWISE IMPELLER
4	STAINLESS STEEL IMPELLER BOLT AND WASHER
5	STEEL PUMP BASE
6	CAST IRON CLOCKWISE VOLUTE
7	COOL AGIVENT® U.S. PAT. NO. 1,105,478
8	ADAPTOR PLATE (NOT SHOWN)
	ALL HARDWARE STAINLESS STEEL

JOB # _____ SR # _____
 CUSTOMER NAME: _____
 CERTIFIED BY: _____
 DATE: _____

ENGINEERS SALES-SERVICE CO., INC.
ESCO PUMPS
 SUBMERSIBLE VORTEX PUMPS
 100% RECESSED IMPELLER

DATE: 1/84

1-7-84