

**GUIDANCE MANUAL
FOR
COMPLIANCE WITH THE
FILTRATION AND DISINFECTION REQUIREMENTS
FOR
PUBLIC WATER SYSTEMS
USING
SURFACE WATER SOURCES**

MARCH 1991 EDITION



**SCIENCE AND TECHNOLOGY BRANCH
CRITERIA AND STANDARDS DIVISION
OFFICE OF DRINKING WATER
U.S. ENVIRONMENTAL PROTECTION AGENCY
WASHINGTON, D.C.**

Printed on Recycled Paper

**GUIDANCE MANUAL
FOR
COMPLIANCE WITH THE
FILTRATION AND DISINFECTION REQUIREMENTS
FOR
PUBLIC WATER SYSTEMS
USING
SURFACE WATER SOURCES**

for

**Science and Technology Branch
Criteria and Standards Division
Office of Drinking Water
U.S. Environmental Protection Agency
Washington, D.C.**

Contract No. 68-01-6989

by

**Malcolm Pirnie, Inc.
100 Eisenhower Drive
Paramus, New Jersey 07653**

**HDR Engineering, Inc.
5175 Hillside Circle
Eldorado Hills, CA 95630**

October, 1990

Acknowledgments

Preparation of this document involved important contributions from many people in two consulting engineering firms, several private consultants, and the United States Environmental Protection Agency (USEPA). Malcolm Pirnie, Inc., with technical contributions provided by HDR Engineering Inc., conducted the day-to-day work under contract with the USEPA.

Principal authors from Malcolm Pirnie were David J. Hildebrand and Linda Averell Wancho. Personnel from HDR involved in this work were Jerry Troyan and Perri P. Garfinkel. Additional personnel from Malcolm Pirnie who contributed to either the technical content or the preparation of the manual included: John E. Dyksen, James K. Schaefer, Scott L. Phillips and Peter B. Galant.

Private consultants who contributed to the document included: Dr. Appiah Amirtharajah, Georgia Institute of Technology, Atlanta, GA; Dr. Ovadia Lev, Hebrew University, Jerusalem, Israel; Dr. Vincent Oliveri, formerly John Hopkins University, Baltimore, MD; Dr. Phillip C. Singer, University of North Carolina, Chapel Hill, NC; Dr. Mark Wiesner, Rice University, Houston, TX.

Preparation of the document was overseen by Stig Regli, the USEPA project officer. Valuable technical review and major contributions to the text were provided by Thomas Grubbs, Office of Drinking Water, USEPA, and Leigh Woodruff, Region X, USEPA.

Special thanks are given to the following individuals working for USEPA whose review and comment on numerous drafts greatly contributed to the evolution of this document: John Davidson, Office of Policy, Planning and Evaluation; Edwin Geldreich, Drinking Water Research Division, Office of Research and Development; John Hoff, formerly with Drinking Water Research Division, Office of Research and Development; Walt Jakubowski, Environmental Monitoring and Support Laboratory, Office of Research and Development; Dr. Gary Logsdon, formerly with Drinking Water Research Division, Office of Research and Development; Kevin Reilly, Region I; Margaret Silver, Office of General Council; and Jim Westrick, Technical Support Division, Office of Drinking Water.

Appreciation is also expressed to state public health officials, representatives of the drinking water industry, academicians, and the American public for their participation in submitting timely and insightful comments without which this document would not have been possible.

Some of the appendices have primary authors which are noted on the corresponding cover pages.

TABLE OF CONTENTS

1. INTRODUCTION

2. GENERAL REQUIREMENTS

- 2.1 Application
- 2.1.1 Types of Water Supplies
- 2.1.2 Determination of Applicable Sources
- 2.2 Treatment Requirements
- 2.3 Operator Personnel Qualifications

3. COMPLIANCE FOR SYSTEMS NOT FILTERING

- 3.1 Source Water Quality Criteria
 - 3.1.1 Coliform Concentrations
 - 3.1.2 Turbidity Levels
- 3.2 Disinfection Criteria
 - 3.2.1 Inactivation Requirements
 - 3.2.2 Determination of Overall Inactivation for Residual Profile, Multiple Disinfectants and Multiple Sources and Multiple Sources
 - 3.2.3 Demonstration of Maintaining a Residual
 - 3.2.4 Disinfection System Redundancy
- 3.3 Site-Specific Conditions
 - 3.3.1 Watershed Control Program
 - 3.3.2 On-site Inspection
 - 3.3.3 No Disease Outbreaks
 - 3.3.4 Monthly Coliform MCL
 - 3.3.5 Total Trihalomethane (TTHM) Regulations

4. DESIGN AND OPERATING CRITERIA FOR FILTRATION AND DISINFECTION TECHNOLOGY

- 4.1 Introduction
- 4.2 Selection of Appropriate Filtration Technology
 - 4.2.1 General Descriptions
 - 4.2.2 Capabilities
 - 4.2.3 Selection
- 4.3 Available Filtration Technologies
 - 4.3.1 Introduction
 - 4.3.2 General
 - 4.3.3 Conventional Treatment
 - 4.3.4 Direct Filtration
 - 4.3.5 Slow Sand Filtration
 - 4.3.6 Diatomaceous Earth Filtration
 - 4.3.7 Alternate Technologies
 - 4.3.8 Nontreatment Alternatives
- 4.4 Disinfection
 - 4.4.1 General
 - 4.4.2 Recommended Removal/Inactivation
 - 4.4.3 Total Trihalomethane (TTHM) Regulations

5. CRITERIA FOR DETERMINING IF FILTRATION AND DISINFECTION ARE SATISFACTORILY PRACTICED

- 5.1 Introduction
- 5.2 Turbidity Monitoring Requirements
 - 5.2.1 Sampling Location
 - 5.2.2 Sampling Frequency
 - 5.2.3 Additional Monitoring
- 5.3 Turbidity Performance Criteria
 - 5.3.1 Conventional Treatment or Direct Filtration
 - 5.3.2 Slow Sand Filtration
 - 5.3.3 Diatomaceous Earth Filtration
 - 5.3.4 Other Filtration Technologies
- 5.4 Disinfection Monitoring Requirements
- 5.5 Disinfection Performance Criteria
 - 5.5.1 Minimum Performance Criteria Required Under the SWTR
 - 5.5.2 Recommended Performance Criteria
 - 5.5.3 Disinfection By-Product Considerations
 - 5.5.4 Recommended Disinfection System Redundancy
 - 5.5.5 Determination of Inactivation by Disinfection
- 5.6 Other Considerations

6. REPORTING

- 6.1 Reporting Requirements for Public Water Systems Not Providing Filtration
- 6.2 Reporting Requirements for Public Water Systems Using Filtration

7. COMPLIANCE

- 7.1 Introduction
- 7.2 Systems Using a Surface Water Source Not Ground Water Under the Direct Influence of Surface Water)
- 7.3 Compliance Transition with Current NPDWR Turbidity Requirements
- 7.4 Systems Using a Ground Water Source Under the Direct Influence of a Surface Water
- 7.5 Responses for Systems not Meeting the SWTR Criteria
 - 7.5.1 Introduction
 - 7.5.2 Systems Not Filtering
 - 7.5.3 Systems Currently Filtering

8. PUBLIC NOTIFICATION

9. EXEMPTIONS

- 9.1 Overview of Requirements
- 9.2 Recommended Criteria
- 9.3 Compelling Factors
- 9.4 Evaluation of Alternate Water Supply Sources
- 9.5 Protection of Public Health
- 9.6 Notification to EPA

List of Tables

Table	Description
2-1	Survey Form for the Classification of Drinking Water Sources
4-1	Removal Capabilities of Filtration Processes
4-2	Generalized Capability of Filtration Systems to Accommodate Raw Water Quality Conditions
6-1	Source Water Quality Conditions for Unfiltered Systems
6-2	Long Term Source Water Quality Conditions for Unfiltered Systems
6-3	CT Determination for Unfiltered Systems Monthly Report to Primacy Agency
6-4	Disinfection Information for Unfiltered Systems Monthly Report to Primacy Agency
6-5	Distribution System Disinfectant Residual Data for Unfiltered and Filtered Systems - Monthly Report to Primacy Agency
6-6	Monthly Report to Primacy Agency for Compliance Determination - Unfiltered Systems
6-7	Daily Data Sheet for Filtered Systems
6-8	Monthly Report to Primacy Agency for Compliance Determination-Filtered Systems
7-1	Requirements for Unfiltered Systems
7-2	Requirements for Filtered Systems
2-1	Steps to Source Classification
3-1	Determination of Inactivation for Multiple Disinfectant Application to a Surface Water Source
3-2	Individually Disinfected Surface Sources Combined at a Single Point
3-3	Multiple Combination Points for Individually Disinfected Surface Sources
4-1	Flow Sheet for a Typical Conventional Water Treatment Plant
4-2	Flow Sheet for Typical Softening Treatment Plants
4-3	Flow Sheet for a Typical Direct Filtration Plant
4-4	Flow Sheet for a Typical Direct Filtration Plant with Flocculation

LIST OF APPENDICES

<i>Appendix</i>	<i>Description</i>
A	Use of Particulate Analysis for Source and Water Treatment Evaluation
B	Institutional Control of Legionella
C	Determination Of Disinfectant Contact Time D Analytical Requirements of the SWTR and a Survey of the Current Status of Residual Disinfectant Measurement Methods for all Chlorine Species and Ozone
E	Inactivation Achieved by Various Disinfectants
F	Basis for CT Values
G	Protocol for Demonstrating Effective Disinfection
H	Sampling Frequency for Total Coliforms in the Distribution System
I	Maintaining Redundant Disinfection Capability
J	Watershed Control Program
K	Sanitary Survey
L	Small System Considerations
M	Protocol for Demonstration of Effective Treatment
N	Protocols for Point-of-Use Treatment Devices
O	Guidelines to Evaluate Ozone Disinfection

1. INTRODUCTION

This Guidance Manual complements the filtration and disinfection treatment requirements for public water systems using surface water sources or ground water under the direct influence of surface water promulgated in 40 CFR Part 141, Subpart H. In this manual, these requirements are referred to as in the Surface Water Treatment Rule (SWTR).

The purpose of this manual is to provide guidance to United States Environmental Protection Agency (USEPA) Regional Offices, Primacy Agencies and affected utilities in the implementation of the SWTR, and to help assure that implementation is consistent. For example, the SWTR sets treatment requirements which apply to a large range of source water conditions. The guidance manual suggests design, operating and performance criteria for specific surface water quality conditions to provide the optimum protection from microbiological contaminants. These recommendations are presented as advisory guidelines only; unlike the provisions of the SWTR, these recommendations are not mandatory requirements. In many cases, it will be appropriate to tailor requirements to specific circumstances; the guidance manual is designed to give the Primacy Agency flexibility in establishing the most appropriate treatment requirements for the systems within their jurisdiction.

Throughout this document, the term "Primacy Agency" refers to a State with primary enforcement responsibility for public water systems or "primacy," or to mean EPA in the case of a State that has not obtained primacy.

In order to facilitate the use of this manual, it has been structured to follow the framework of the SWTR as closely as possible. Brief descriptions of the contents of each section of this manual are presented in the following paragraphs.

Section 2

This section provides guidance for determining whether a water supply source is subject to the requirements of the SWTR including the determination of whether a ground water source is under the direct

influence of surface water, i.e. at risk for the presence of Giardia cysts or other large microorganisms. The overall treatment requirements of the SWTR are also presented, along with recommendations for the qualifications of operator personnel.

Section 3

For systems which are subject to the requirements of the SWTR and which do not currently provide filtration, this section provides guidance to the Primacy Agency for determining if a given system:

- Meets the source water quality criteria
- Meets the disinfection requirements including:
 - 99.9 and 99.99 percent inactivation of Giardia cysts and viruses and application of the CT (disinfectant residual concentration x contact time) concept
 - Point of entry to distribution system requirements
 - Distribution system requirements
 - Provision for disinfection system redundancy
- Maintains an adequate watershed control program
- Meets the on-site inspection requirements
- Has not had an identified waterborne disease outbreak
- Complies with the requirements of the revised Total Coliform Rule
- Complies with Total Trihalomethane (TTHM) Rule

Section 4

This section pertains to systems which do not meet the requirements to avoid filtration outlined in Section 3 and therefore are required to install filtration. Guidance is given for the selection of an appropriate filtration technology based on the source water quality and the capabilities of various technologies to achieve the required performance criteria. In addition, recommended design and operating criteria are provided for different filtration technologies.

Section 5

Section 5 presents guidance to the Primacy Agency for determining compliance with the turbidity and disinfection performance requirements, and in turn, whether filtration and disinfection are satisfactorily practiced. Recommendations are made for the level of disinfection to be provided in order to meet the overall treatment requirements of the SWTR. This section describes how to evaluate the adequacy of disinfection using CT or other methods.

Section 6

Section 6 provides guidelines to the Primacy Agency for establishing the reporting requirements associated with the SWTR. The requirements include report content and frequency, and are applicable to both filtering and nonfiltering systems.

Section 7

This section provides an overview of the schedule for Primacy Agencies and utilities to meet the requirements of the SWTR. Examples are presented to provide guidance for corrective measures which can be taken by systems which are not in compliance with the treatment requirements.

Section 8

This section presents guidance on public notification. Included are examples of events which would require notification, language for the notices and the methods of notification.

Section 9

Section 9 provides guidance to the Primacy Agency for determining whether a system is eligible for an exemption. The criteria for eligibility for an exemption include:

- Compelling factors (economic or resource limitations)
- No available alternate source
- Protection of public health

This section also provides guidance for evaluating the financial capabilities of a water system, reviewing the availability of alternate sources and suggests interim measures for protecting public health.

Appendices

The manual also contains appendices which provide more detailed guidance in specific areas. These include:

Appendix A - EPA Consensus Method for Giardia cyst Analysis

Several procedures are available for Giardia cyst analysis in water. In 1983 the USEPA held a conference to establish a consensus on the procedure to be used in the future. This consensus method would promote uniformity in testing and provide a basis for future comparisons. The consensus method and the background data used to develop it are presented in this appendix.

Appendix B - Institutional Control of Legionella

Filtration and/or disinfection provides protection from Legionella. However, it does not assure that recontamination or regrowth will not occur in the hot water or cooling systems of buildings within the distribution system. This appendix provides guidance for monitoring and treatment which can be used by institutional systems for the control of Legionella.

Appendix C - Determination of Disinfectant Contact Time

In many cases, the determination of disinfectant contact times needed to evaluate the CT of a water system will necessitate the use of tracer studies. This appendix provides guidance for conducting these studies. In some cases it may not be practical to conduct a tracer study. For such cases guidance is given for estimating the detention time based on the physical configuration of the system.

**Appendix D - Analytical Requirements
of the SWTR and A Survey of the Current
Status of Residual Disinfectant
Measurement Methods for all Chlorine
Species and Ozone**

This appendix includes a listing of the analytical methods required under the SWTR. An executive summary of a report on the analytical methods used to measure the residual concentrations of the various disinfectants is included. The reliability and limitations of each of the methods are presented.

**Appendix E - Inactivations Achieved
by the Various Disinfectants**

This appendix presents the log inactivations of Giardia cysts and viruses which are achieved at various CT levels by chlorine, chlorine dioxide, chloramines and ozone. Inactivations of viruses achieved by UV absorbance are also included.

Appendix F - Basis for CT Values

This appendix provides the background and rationale utilized in developing the CT values for the various disinfectants. Included is a paper by Clark and Regli, 1990, in which a mathematical model was used in the determination of CT values for free chlorine.

**Appendix G - Protocol for Demonstrating
Effective Disinfection**

This appendix provides the recommended protocols for demonstrating the effectiveness of chloramines, chlorine dioxide and ozone as primary disinfectants.

**Appendix H - Sampling Frequency for
Total Coliforms in the Distribution System**

The sampling frequency required by the revised Total Coliform Rule 54 FR 27544 (June 29, 1989) is presented in this appendix.

**Appendix I - Maintaining
Redundant Disinfection Capability**

This appendix details the conditions and equipment which should be maintained by a system using chlorine, chlorine dioxide, ozone or chloramines to assure that compliance with the SWTR requirement for redundant disinfection is met.

Appendix J - Watershed Control Program

This appendix provides a detailed outline of a watershed program. This program may be adjusted by the Primacy Agency to serve the specific needs of a particular water system.

Appendix K - Sanitary Survey

This appendix provides guidance for conducting a comprehensive sanitary survey of a supply source and its treatment and delivery to the consumer. Suggested elements of an annual on-site inspection are included in Section 3.

Appendix L - Small System Considerations

This appendix describes difficulties which may be faced by small systems in complying with the SWTR along with guidelines for overcoming these difficulties.

**Appendix M - Protocol for the
Demonstration of Effective Treatment**

This appendix presents pilot study protocols to evaluate the effectiveness of an alternate filtration technology in meeting the performance requirements of the SWTR. It presents the use of particle size analysis for demonstrating the actual removal of Giardia cyst achieved by a treatment train. Guidance for conventional and direct filtration plants to demonstrate that adequate filtration is being maintained at effluent turbidities between 0.5 and 1 Nephelometric Turbidity Unit (NTU) is also included.

**Appendix N - Protocol for
Point-of-Use Treatment Devices**

In some limited cases, it may be appropriate to install point-of-use (POU) or point-of-entry (POE) treatment devices as an interim measure to provide protection to the public health. This appendix provides a protocol for evaluating and determining the efficacy of POU/POE treatment devices.

**Appendix O - Guidelines to
Evaluate Ozone Disinfection**

The CT evaluation used for other disinfectants is inappropriate for ozone. This appendix presents alternative methods for evaluating the disinfection effectiveness of ozone systems.

2. GENERAL REQUIREMENTS

2.1 Application

The SWTR pertains to all public water systems which utilize a surface water source or ground water source under the direct influence of surface water. The SWTR defines a surface water as all waters which are open to the atmosphere and subject to surface runoff. Ground water under the direct influence of surface water is defined as: any water beneath the surface of the ground with (i) significant occurrence of insects or other macroorganisms, algae, organic debris, or large-diameter pathogens such as Giardia lamblia, or (ii) significant and relatively rapid shifts in water characteristics such as turbidity, temperature, conductivity, or pH which closely correlate to climatological or surface water conditions. Direct influence must be determined for each individual source in accordance with criteria established by the Primacy Agency. The Primacy Agency criteria may provide for documentation of well construction and geology, with field evaluation, or site-specific measurements of water quality as explained in Section 2.1.2.

Saline water sources such as the ocean are not generally considered to be subject to the requirements of the SWTR because of the low survival time of pathogens in a saline environment (Geldreich, 1989). Pathogens generally can only survive a few hours in saline water and any remaining pathogens should be removed or inactivated during desalination. However, it is up to the Primacy Agency's discretion to determine which systems must meet the SWTR requirements. In cases where there is a sewage discharge located near the water intake, it may be appropriate for the Primacy Agency to require the system to comply with the SWTR.

The traditional concept that all water in subsurface aquifers is free from pathogenic organisms is based upon soil being an effective filter that removes microorganisms and other relatively large particles by straining and antagonistic effects (Bouwer, 1978). In most cases pathogenic bacteria retained in the soil find themselves in a hostile environment, are not able to multiply and eventually die. However, some underground sources of drinking water may be subject to contamination by pathogenic organisms from the direct influence of nearby surface waters.

Only those subsurface sources which are at risk to contamination from Giardia cysts will be subject to the requirements of the SWTR. Giardia

cysts generally range in size from 7 to 12 um. Subsurface sources which may be at risk to contamination from bacteria and enteric viruses, but which are not at risk from Giardia cysts will be regulated either under the Total Coliform Rule or forthcoming disinfection treatment requirements for ground waters. EPA intends to promulgate disinfection requirements for ground water systems in conjunction with regulations for disinfection by-products by 1992.

2.1.1 Types of Water Supplies

Surface Waters

Surface water supplies that are often used as sources of drinking water include two major classifications, running and quiescent waters. Streams, rivers and brooks are examples of running water, while lakes, reservoirs, impoundments and ponds are examples of quiescent waters. The exposure of surface waters to the atmosphere results in exposure to precipitation events, surface water runoff and contamination with micro and macroorganisms resulting from activities in their surrounding areas. These sources are subject to the requirements of the SWTR.

Systems with rain water catchments not subject to surface runoff (e.g. roof catchment areas) are not considered vulnerable to contamination from animal populations which carry protozoan cysts pathogenic to humans and are thus not subject to the SWTR requirements. However, such systems should at least provide disinfection to treat for potential bacterial and viral contamination coming from bird populations.¹

Ground Waters under Direct Influence of Surface Water

Ground water sources which may be subject to contamination with pathogenic organisms from surface waters include, springs, infiltration galleries, wells or other collectors in subsurface aquifers. The following section presents a recommended procedure for determining whether a source will be subject to the requirements of the SWTR. These determinations are to be made for each individual source. If the determination will involve an evaluation of water quality, eg. particulate analysis, it is important that these analyses be made on water taken

¹ One study (Markwell and Shortridge, 1981) indicates that a cycle of waterborne transmission and maintenance of influenza virus may exist within duck communities, and that it is conceivable for virus transmission to occur in this manner to other susceptible animals, including humans.

directly from the source and not on blended water or water from the distribution system.

2.1.2 Determination of Applicable Sources

The Primacy Agency has the responsibility for determining which water supplies must meet the requirements of the SWTR. However, it is the responsibility of the water purveyors to provide the Primacy Agency with the information needed to make this determination. This section provides guidance to the Primacy Agency for determining which water supplies are surface waters or ground waters directly influenced by a surface water and are thereby subject to the requirements of the SWTR. Following the determination that the source is subject to the SWTR, the requirements enumerated in Sections 2.2 and 2.3 must be met.

The Primacy Agency must develop a program for evaluating ground water sources for direct influence by December 30, 1990. All community ground water systems must be evaluated by June 29, 1994, while all non-community systems must be evaluated by June 29, 1999. Primacy Agencies with an approved Wellhead Protection (WHP) Program, may be able to use the WHP program's requirements which include delineation of wellhead protection areas, assessment of sources of contamination and implementation of management control measures. These same requirements can be used for meeting the requirements of the watershed control program for ground water under the direct influence of a surface water.

A multiple step approach has been developed as the recommended method of determining whether a ground water source is under direct influence of a surface water. This approach includes the review of information gathered during sanitary surveys. As defined by the USEPA, a sanitary survey is an on-site review of the water source, facilities, equipment operation and maintenance of a public water system for the purpose of evaluating the adequacy of such source, facilities, equipment, operation and maintenance for producing and distributing safe drinking water. Sanitary surveys are required under the Total Coliform Rule and may be required under the forthcoming disinfection requirements for ground water systems as a condition for obtaining a variance or for determining the level of disinfection required. Therefore, it is recommended that the determination of direct influence be correlated with the sanitary surveys conducted under these other requirements.

A. Source Evaluation Protocol

As illustrated on Figure 2-1, the determination of whether a source is subject to the requirements of the SWTR may involve one or more of the following steps:

1. A review of the records of the system's source(s) to determine whether the source is obviously a surface water, i.e. pond, lake, streams, etc.
2. If the source is a well, determination of whether it is clearly a ground water source, or whether further analysis is needed to determine possible direct surface water influence.
3. A complete review of the system's files followed by a field sanitary survey. Pertinent information to gather in the file review and field survey includes: source design and construction; evidence of direct surface water contamination; water quality analysis; indications of waterborne disease outbreaks; operational procedures (i.e. pumping rates, etc.); and customer complaints regarding water quality or water related infectious illness.
4. Conducting particulate analyses and other water quality sampling and analyses.

Step 1. Records Review

A review of information pertaining to each source should be carried out to identify those sources which are obvious surface waters. These would include ponds, lakes, streams, rivers, reservoirs, etc. If the source is a surface water, then the SWTR would apply, and criteria in the rule would need to be applied to determine if filtration is necessary. If the source is not an obvious surface water, then further analyses, as presented in Steps 2, 3, or 4, are needed to determine if the SWTR will apply. If the source is a well (vertical or horizontal), go to Step 2. If the source is a spring, infiltration gallery, or any other subsurface source, proceed to Step 3 for a more detailed analysis.

Step 2. Review of Well Sources

While most well sources have historically been considered to be ground water, recent evidence suggests that some wells, especially shallow wells constructed near surface waters, may be directly influenced by surface water. One approach in determining whether a well is subject to contamination by surface water would be to evaluate the water quality of the well by the criteria in Step 4. However, this process is rather time

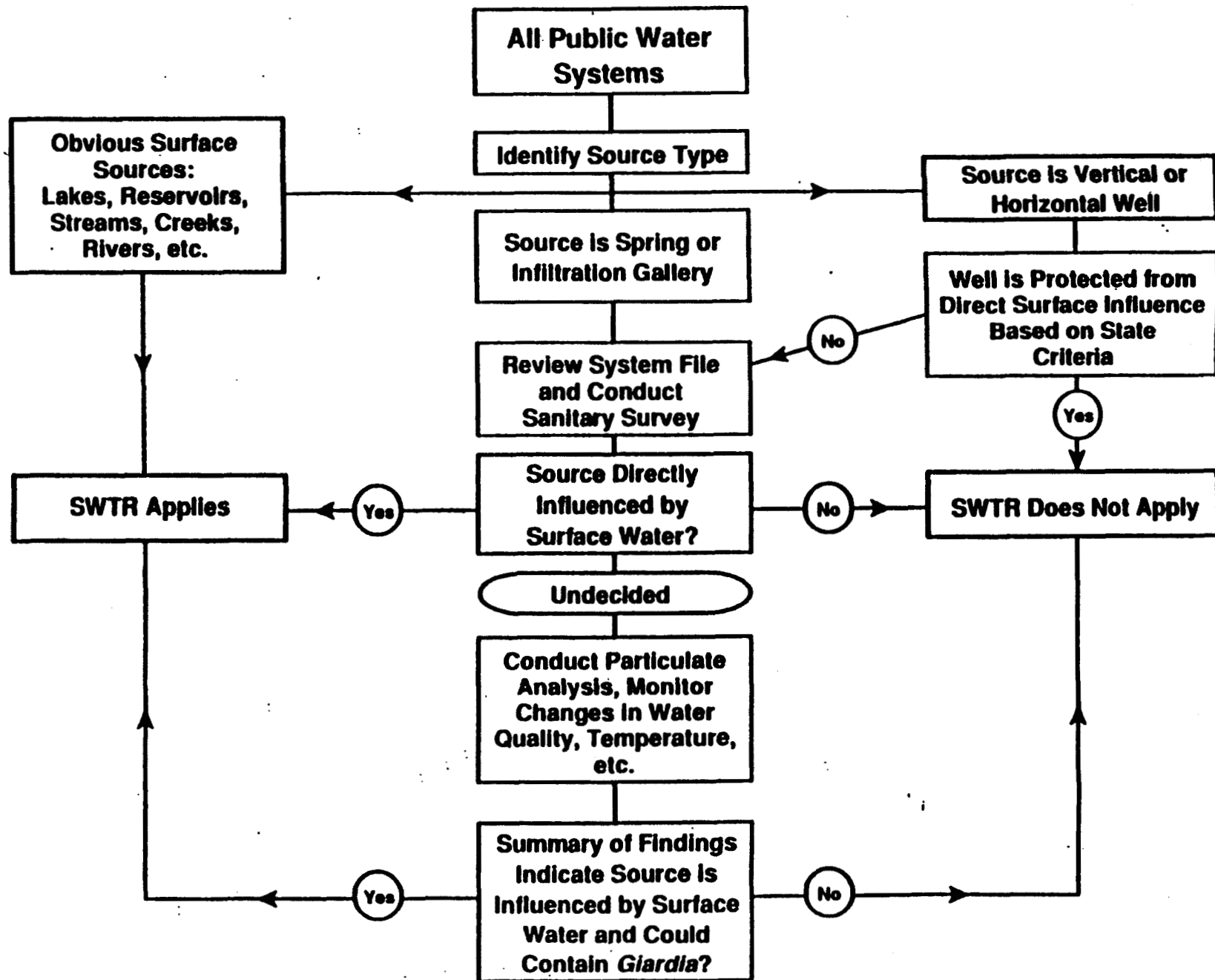

FIGURE 2-1 - STEPS TO SOURCE CLASSIFICATION

consuming and labor intensive. In an attempt to reduce the effort needed to evaluate well sources, a set of criteria has been developed to identify wells in deep, well protected aquifers which are not subject to contamination from surface water. While these criteria are not as definitive as water quality analysis, it is believed that they provide a reasonable degree of accuracy, and allow for a relatively rapid determination for a large number of well sources in the U.S.

Wells with perforations or a well screen less than or equal to 50 feet in depth are considered to be shallow wells, and should be evaluated for direct surface influence according to steps 3 and/or 4. For wells greater than 50 feet in depth, State or system files should be reviewed for the criteria listed below:

1. The well construction should include:
 - A surface sanitary seal using bentonite clay, concrete or other acceptable material.
 - A well casing that penetrates a confining bed.
 - A well casing or collector laterals that are only perforated or screened below a confining bed.

The importance of evaluating the hydrogeology of wells or collectors, even those more than 200 feet from a surface water, cannot be overstated. The porosity and transmissivity of aquifer materials, hydrologic gradients, and continuity of confining layers above screens or perforations may need to be considered in detail for some sources. Porous aquifer material is more likely to allow surface water to directly influence ground water than finer grained materials. In addition, high well pumping rates may alter the existing hydrologic gradient. Ground water flow direction may change such that surface water is drawn into a collector, whereas under low pumping rates it may not. Evaluating pumping rate effects and other hydrogeologic information must be done on a site specific basis.

If information on well construction or hydrogeology are incomplete or raise questions regarding potential surface water influence, a more detailed analysis in steps 3 and 4 should be considered.

2. The casing or nearest collector lateral should be located at least 200 feet from any surface water.
3. The water quality records should indicate:

- No record of total coliform or fecal coliform contamination in untreated samples collected over the past three years.
- No history of turbidity problems associated with the source.
- No history of known or suspected outbreak of Giardia, or other pathogenic organism associated with surface water (e.g. Cryptosporidium), which has been attributed to that source.

4. If data is available for particulate matter in the well there should be:

- No evidence of particulate matter associated with surface water.

If data is available for turbidity or temperature from the well and a nearby surface water there should be:

- No turbidity or temperature data which correlates to that of a nearby surface water.

Wells that meet all of the criteria listed above are not subject to the requirements of the SWTR, and no additional evaluation is needed. Wells that do not meet all the requirements listed require further evaluation in accordance with Steps 3 and/or 4 to determine whether or not they are directly influenced by surface water.

Step 3. On-site Inspection

For sources other than a well source, the State or system files should be reviewed for the source construction and water quality conditions as listed in Step 2. Reviewing historical records in State or system files is a valuable information gathering tool for any source. However, the results may be inconclusive. A sanitary survey in the field may be helpful in establishing a more definite determination of whether the water source is at risk to pathogens from direct surface water influence.

Information to obtain during an on-site inspection include:

- Evidence that surface water enters the source through defects in the source such as lack of a surface seal on wells, infil-

tration gallery laterals exposed to surface water, springs open to the atmosphere, surface runoff entering a spring or other collector, etc.

- Distances to obvious surface water sources.

If the survey indicates that the well is subject to direct surface water influence, the source must either be reconstructed as explained later in this section or it must be treated in accordance with the requirements for the SWTR. If the survey does not show conclusive evidence of direct surface water influence, the analysis outlined in Step 4 should be conducted.

The Washington State Department of Social and Health Services has developed a form to guide them and provide consistency in their evaluation of sources for surface water influence (Notestine & Hudson, 1988). Table 2-1 provides a copy of this form as a guide for evaluating sources.

Step 4. Particulate Analysis and Other Indicators

a. Surface Water Indicators

Particulate analysis is intended to identify organisms which only occur in surface waters as opposed to ground waters, and whose presence in a ground water would clearly indicate that at least some surface water has been mixed with it. The EPA Consensus Method in Appendix A can be used for Giardia cyst analysis.

In 1986 Hoffbuhr et. al. listed six parameters identifiable in a particulate analysis which were believed to be valid indicators of surface contamination of ground water. These were: diatoms, rotifers, coccidia, plant debris, insect parts, and Giardia cysts. Later work by Notestine and Hudson (1988) found that microbiologists did not all define plant debris in the same way, and that deep wells known to be free of direct surface water influence were shown by particulate analysis to contain "plant debris" but none of the other five indicators. Their work suggests that "plant debris" may not currently be a useful tool in determining direct surface water influence, but may be in the future when a standard definition of "plant debris" is developed. Therefore, it is recommended that only the presence of the other five parameters; diatoms and certain other algae, rotifers, coccidia, insect parts, and Giardia, be used as

TABLE 2-1

SURVEY FORM FOR THE CLASSIFICATION OF DRINKING WATER SOURCES

General

1. Utility Name (ID#) _____
 2. Utility Person(s) Contacted _____
 3. Source Type (As shown on state inventory)
 Spring Horizontal Well Vertical Well
 Infiltration System Shallow Well
 4. Source Name _____ Year constructed _____
 5. Is this source used seasonally or intermittently? No Yes
If yes, are water quality problems the reason? No Yes
 6. Has there ever been a waterborne disease outbreak associated with this source? Yes No If yes, explain _____

 7. Have there been turbidity or bacteriological MCL violations within the last five years associated with this source? No Yes
If yes, describe frequency, cause, remedial action (s) taken _____

 8. Have there been consumer complaints within the past five years associated with this source? No Yes If yes, discuss nature, frequency, remedial action taken _____

 9. Is there any evidence of surface water intrusion (pH, temperature, conductivity, etc. changes) during the year? Yes No
If yes, describe _____

- If not, submit supporting data.
10. Sketch of source in plan view (on an additional sheet)

Shallow Wells

1. Does the well meet good sanitary practices regarding location, construction, seal etc. to prevent the entrance of surface water?
Yes _____ No _____ If no, describe the deficiencies _____

2. What is the depth of the well? _____ (ft)
Elevation of top of casing? _____ (ft msl)
Elevation of land surface? _____ (ft msl)

3. Hydrogeology (Attach copy of well log or summarize it on reverse)
 - a. Depth to static water level? (Feet) _____
 - b. Drawdown? (Feet) _____
 - c. What is the depth to the highest screen or perforation?
(Feet) _____
 - d. Are there impervious layers above the highest screen of
perforation?
Yes _____ No _____ Unknown _____
If yes, please describe _____

4. Is there a permanent or intermittent surface water within 200 feet
of the well? Yes _____ No _____ If yes, describe (type, distance
etc.) and submit location map

What is the elvation of normal pool? _____ (ft msl)
Elevation of 100 year flood level? _____ (ft msl)
Elevation of bottom of lake or river? _____ (ft msl)

5. Additional comments: _____

Springs

1. a. What is the size of the catchment area (acres)? _____
b. Give a general description of the area (terrain; vegetation; soil etc.)

2. What is the vertical distance between the ground surface and the nearest point of entry to the spring collector(s) (feet)? _____

3. How rapidly does rainfall percolate into the ground around the spring?
____ Percolates readily; seldom if ever any runoff.
____ Percolates readily but there is some runoff in heavy rain.
____ Percolates slowly. Most local rainfall ponds or runs off.
____ Other _____

4. Does an impervious layer prevent direct percolation of surface water to the collector(s)? Yes _____ No _____ Unknown _____

5. Is the spring properly constructed to prevent entry of surface water? Yes _____ No _____

6. Sediment
 - a. Is the spring box free of debris and sediment? Yes ___ No ___
 - b. When was it last cleaned (Date) _____
 - c. How often does it need to be cleaned? (month) _____
 - d. How much sediment accumulates between cleaning? (estimate in inches)

7. Additional comments: _____

Infiltration Systems

1. What are the shortest distances (vertical and horizontal separating the collector from the nearest surface water? (Feet) _____

2. Does turbidity of the source vary 0.2 NTU or more throughout the year? Yes _____ No _____ Not measured _____
If yes, describe how often and how much (pH, temperature, conductivity, etc.)

3. Additional Comments _____

Survey Conducted By: _____ Date: _____

Decision? Surface Impacted Source Yes _____ No _____ If no, further evaluation needed (particulate analysis, etc.)

indicators of direct surface contamination. In addition, if other large diameter (> 7 um) organisms which are clearly of surface water origin such as Diphilobothrium are present, these should also be considered as indicators of direct surface water influence.

b. Interpretation

Since standard methods have not been developed specifically for particulate analysis, there has not been consistency in the way samples have been collected and analyzed. Differences in the degree of training and experience of the microbiologists has added further to the difficulty in comparing results from sample to sample, and system to system. The current limitations in sample collection and analytical procedures must be considered when interpreting the results. Until standardized methods are developed, the EPA Consensus Method included in Appendix A is recommended as the analytical method for particulate analysis. The following is a discussion of the significance of finding the six indicators identified above.

Identification of a Giardia cyst in any source water should be considered conclusive evidence of direct surface water influence. The repeated presence of diatoms in source water should be considered as conclusive evidence of direct surface water influence. However, it is important that this determination be based on live diatoms, and not empty silica skeletons which may only indicate the historical presence of surface water.

Bluegreen, green, or other chloroplast containing algae require sunlight for their metabolism as do diatoms. For that reason their repeated presence in source water should also be considered as conclusive evidence of direct surface water influence.

Hoffbuhr (1986) indicates that rotifers and insect parts are indicators of surface water. Others have pointed out though that rotifers do not require sunlight, and not all rotifers require a food source such as algae which originates in surface water. Their nutritional requirements may be satisfied by organic matter such as bacteria, or decomposing soil organic material, not necessarily associated with surface water. More precise identification of rotifers, i.e. to the species level, is necessary to determine the specific nutritional requirements of the rotifer(s) present. Further information on identifying rotifer species and on which species require food sources originating in surface water,

would be valuable, but is not readily available at this time. Without knowledge of which species is present, the finding of rotifers indicates that the source is either a) directly influenced by surface water, or b) it contains organic matter sufficient to support the growth of rotifers. It could be conservatively assumed based on this evidence alone that such a source is directly influenced by surface water. However, it is recommended that this determination be supported by other evidence, eg. the source is near a surface water, turbidity fluctuations are significant, etc.

Insects or insect parts likewise may originate in surface water, from the soil, or they may be airborne in uncovered sources. If insects are observed in a particulate analysis sample, it should be confirmed if possible that there is no other route by which insects could contaminate the source other than surface water. For example, if a spring is sampled, and the cover is not well constructed, it is possible that insects found in a sample were airborne rather than waterborne. Insects which spend a portion of their lifecycle in water are the best indicators of direct surface water influence, for example, larvae of mayflies, stoneflies, damselflies, and dragonflies. Terrestrial insects should not be ruled out as surface water indicators though, since their accidental presence in surface water is common.

Howell, (1989) has indicated that some insects may burrow and the finding of eggs or burrowing larvae (eg. chironomids) may not be good indicators of direct surface water influence. For some insects this may be true, but the distance which insects burrow in subsurface sediments is expected to be small, and insect larvae are generally large in comparison to Giardia cysts. Until further research suggests otherwise, it is recommended that insects or insect parts be considered strong evidence of surface water influence if not direct evidence in and of themselves. The strength of this evidence would be increased if the source in question is near a surface water, and particulate analysis of the surface water found similar insects.

Coccidia are intracellular parasites which occur primarily in vertebrates, eg. animals and fish, and live in various tissues and organs including the intestinal tract (eg. Cryptosporidium). Though not frequently identified by normal particulate analysis techniques, coccidia are good indicators of direct surface water contamination since they

require a vertebrate host or hosts and are generally large in size (10 - 20 um or greater). Cryptosporidium is commonly found in surface water, but due to its small size (4 - 6 um) it is not normally identified without specific antibody staining techniques.

Other macroorganisms (>7 um) which are parasitic to animals and fish may be found and are good indicators of surface water influence. Examples include, but are not limited to, helminths (e.g., tape worm cysts), ascaris, and Diphyllbothrium.

c. Sampling Method

A suggested protocol for collecting samples is listed below.

- Sampling Procedure

Samples should be collected using the equipment outlined in the EPA Consensus Method included in Appendix A.

- Location

Samples should always be collected as close to the source as possible, and prior to any treatment. If samples must be taken after disinfection, samples should be noted and analyzed as soon as possible.

- Number

A minimum of two samples should be collected during the period the source is most susceptible to surface water influence. Such critical periods will vary from system to system and will need to be determined case by case. For some systems, it may be one or more days following a significant rainfall (eg. 2" in 24 hours). For other systems it may be a period of maximum flows and stream turbidities following spring snowmelt, or during the summer months when water tables are elevated as a result of irrigation. In each case, particulate samples should be collected when the source in question is most effected. A surrogate measure such as source turbidity or depth to water table may be useful in making the decision to monitor. If there is any ambiguity in the particulate analysis results, additional samples should be collected when there is the greatest likelihood that the source will be contaminated by surface water.

- Volume

Sample volume should be between 500 and 1000 gallons, and should be collected over a 4 to 8 hour time period. It is preferable to analyze a similar (+/- 10%) volume of water for all sources, preferably a large volume, although this may not always be possible due to elevated turbidity or sampling logistics. The volume filtered should be recorded for all samples.

d. Other Indicators

A number of other indicators could be used to provide supportive evidence of surface influence. While particulate analysis probably provides the most direct evidence that pathogens from surface water could be migrating into a ground water source, other parameters such as turbidity, temperature, pH and conductivity could provide supportive, but less direct, evidence.

Turbidity fluctuations of greater than 0.5 - 1 NTU over the course of a year may be indicative of surface water influence. Considerable caution should be used when evaluating turbidity changes though, since the turbidity could be caused by very small particles (< 1um) not originating in a surface water or it could be that larger particles are being filtered out and only the very smallest particles migrate into the water source. Only ground water sources at risk to contamination from Giardia or other large pathogens (> 7 um) are subject to the SWTR requirements.

Temperature fluctuations may also indicate surface water influence. Fortunately these are easy to obtain and if there is a surface water within 500 feet of the water source, measurements of both should be recorded for comparison. Large changes in surface water temperature closely followed by similar changes in source temperature would be indicative of surface water influence. Also, temperature changes (in degrees F) of greater than 15 to 20% over the course of a year appear to be a characteristic of some sources influenced by surface water (Randall, 1970). Changes in other chemical parameters such as pH, conductivity, hardness, etc. could also be monitored. Again, these would not give a direct indication of whether pathogens originating in surface water were present, but could indicate whether the water chemistry was or was not similar to a nearby surface water and/or whether source water chemistry changed in a similar pattern to surface water chemistry. At this time no numerical guidelines are available to differentiate what is or is not similar, so these comparisons are more qualitative than quantitative.

B. Seasonal Sources

Some sources may only be used for part of the year, for example during the summer months when water usage is high. These sources should not be excluded from evaluation and, like other sources, should be evaluated during their period(s) of highest susceptibility. Particular

attention should be given to those sources which appear to be directly influenced by surface water during part of the year. There may be times during which these subsurface water sources are not influenced by surface water and other times when they are part or all surface water. If that is the case, then it is critical that careful testing be done prior to, during and at the end of the use of the source. This should be done over several seasons to account for seasonal variation. In practice, it is preferable to use sources which are less vulnerable to contamination since susceptible sources will necessitate ongoing monitoring and close attention to operation.

C. Modification of Sources

Sources directly influenced by surface water may be altered in some cases to eliminate the surface water contamination. Primacy Agencies may elect to allow systems with such sources to modify the construction of the source and/or the area surrounding the source in an effort to eliminate surface water contamination. Since this could be expensive and take considerable time to evaluate for effectiveness, careful consideration should be given to the decision to modify a source. In deciding whether source modification is appropriate, systems and Primacy Agencies should consider the following points:

- Is the cause of the surface water contamination known? If the specific cause or point of surface water contamination is not known, it will not be possible to determine an effective control strategy. Further, there may be several reasons why the source is susceptible to direct surface water influence. For example, an infiltration gallery may receive surface water because some of its laterals are exposed in the bed of a nearby stream, and also because laterals distant from the stream are shallow and are affected by surface runoff. Simply modifying or eliminating one or the other set of laterals in this case would not entirely eliminate surface water influence.
- What is the likelihood that modification of the source will be effective? Assuming that the source of contamination has been identified, the expected effectiveness of control measures should be evaluated. If the cause is relatively evident, a crack in a well casing or an uncovered spring box for example; then there is a high degree of confidence that an effective solution could be developed. Should the nature of the contamination be more diffuse, or widespread, then the merits of spending time and money to modify the source should be carefully considered. In the case of the example above, eliminating the use of the laterals under the stream will solve part of the

problem. However, without considerably more hydrogeologic information about the aquifer and the placement of the other laterals, it is not clear what, if any, control measures would effectively eliminate direct surface water influence in those laterals distant from the stream.

If a source is identified as being directly influenced by surface water, and it is decided to attempt to modify it, interim disinfection practices which will ensure at least 99.9% inactivation of Giardia should be considered. Methods and levels of disinfection which can be used to achieve such removals can be found in S141.72 (a) of the SWTR and in Section 3.2 of this manual.

A partial listing of types of modifications which could be undertaken includes:

- Diverting surface runoff from springs by trenching, etc.
- Redeveloping springs to capture them below a confining layer.
- Covering open spring collectors.
- Reconstructing wells to install sanitary seals, and/or to screen them in a confined (protected) aquifer.
- Repairing cracks or breaks in any type of source collector that allows the entry of surface contaminants.
- Discontinue the use of infiltration laterals which intercept surface water.

An extended period of monitoring should follow reconstruction (eg. through at least two years or critical periods) to evaluate whether the source is still directly influenced by surface water. Preferably particulate analysis would be used to make such evaluations, but it may be helpful to use simpler measures, such as temperature and turbidity, as screening tools. Longer term monitoring at critical times may also be an appropriate agreement between the system and the Primacy Agency if there is still doubt about the long term effectiveness of the solution.

If modification is not feasible, another alternative to avoid having to comply with the SWTR may be to develop a new well either deeper or at a different location.

2.2 Treatment Requirements

According to the SWTR, all community and noncommunity public water systems which use a surface water source or a ground water under the direct influence of a surface water must achieve a minimum of 99.9 percent (3-log) removal and/or inactivation of Giardia cysts, and a minimum of 99.99 percent (4-log) removal and/or inactivation of viruses. In the SWTR and this manual, "viruses" means viruses of fecal origin which are infectious to humans by waterborne transmission. Filtration plus disinfection or disinfection alone may be utilized to achieve these performance levels, depending on the source water quality and site specific conditions. The SWTR establishes these removal and/or inactivation requirements based on Giardia and viruses because this level of treatment will also provide protection from heterotrophic plate count (HPC) bacteria and Legionella² as required in the SDWA amendments.

Guidelines for meeting the requirements of the SWTR are provided in the remainder of this manual as outlined in Section 1. All systems must meet the operator qualifications presented in Section 2.3.

2.3 Operator Personnel Qualifications

The SWTR requires that all systems must be operated by qualified personnel. It is recommended that the Primacy Agency set standards for operator qualifications, in accordance with the system type and size. In order to accomplish this, the Primacy Agency should develop a method of evaluating an operator's competence in operating a water treatment system. Primacy Agencies which do not currently have a certification program are thereby encouraged to implement such a program. An operator certification program provides a uniform base for operator qualifications and an organized system for evaluating these qualifications.

It is recommended that plant operators have a basic knowledge of science, mathematics and chemistry involved with water treatment and supply. The minimum requirements for at least one key staff member should include an understanding of:

² In the SWTR and this manual "Legionella" means a genus of bacteria, some species of which have caused a type of pneumonia called Legionnaires Disease; the etiologic agent of most cases of Legionnaires Disease examined has been L. pneumophila.

- The principles of water treatment and distribution and their characteristics
- The uses of potable water and variations in its demand
- The importance of water quality to public health
- The equipment, operation and maintenance of the distribution system
- The treatment process equipment utilized, its operational parameters and maintenance
- The principles of each process unit (including the scientific basis and purpose of the operation and the mechanical components of the unit)
- Performance criteria such as turbidity, total coliform, fecal coliform, disinfectant residual, pH, etc. to determine operational adjustments
- Common operating problems encountered in the system and actions to correct them
- The current National Primary Drinking Water Regulations, the Secondary Drinking Water Regulations and monitoring and reporting requirements
- Methods of sample collection and sample preservation
- Laboratory equipment and tests used to analyze samples (where appropriate)
- The use of laboratory results to analyze plant efficiency
- Record keeping
- Customer relations
- Budgeting and supervision (where appropriate)

Training in the areas listed above and others is available through the American Water Works Association (AWWA) training course series for water supply operations. The course series includes a set of four training manuals and one reference book as follows:

- Introduction to Water Sources and Transmission (Volume 1)
- Introduction to Water Treatment (Volume 2)
- Introduction to Water Distribution (Volume 3)
- Introduction to Water Quality Analyses (Volume 4)

- Reference Handbook: Basic Science Concepts and Applications
- Instructor Guide and Solutions Manual for Volumes 1, 2, 3 and 4

These manuals are available through the American Water Works Association, 6666 West Quincy Avenue, Denver, Colorado 80235 USA, (303) 794-7711.

The State of California also offers a series of training manuals for water treatment plant operators prepared by the California State University School of Engineering in Sacramento. The manuals include:

1. Water Supply System Operation. (1 Volume)
2. Water Treatment Plant Operation. (2 Volumes)

These operator training manuals are available from California State University, Sacramento, 6000 J Street, Sacramento, California 95819, phone (916) 454-6142.

Completion of an established training and certification program will provide the means of assuring that the operators have received training in their respective area, and are qualified for their position. The education and experience requirements for certification should be commensurate with the size and the complexity of the treatment system. At the present time, some states have instituted a certification program while others have not. Following is a summary of the basic contents of a certification program, which can serve as a guide to the Primacy Agency in developing a complete program.

- Board of examiners for the development and implementation of the program.
- Classification of treatment facilities by grade according to the size and technology of the facilities.
- Educational and experience requirements for operators of the various treatment facilities according to grade.
- A written/oral examination to determine the knowledge, ability and judgement of the applicants with certification obtained upon receiving a passing grade.
- Renewal program for the license of certification, including the requirement of additional coursework or participation in workshops.

The certification program should provide technically qualified personnel for the operation of the plant.

The extensive responsibility which is placed on the operating personnel warrants the development of an outline of the responsibilities and authority of the personnel members to aid them in the efficient operation of the plant. The major responsibilities which should be delegated in the outline of responsibilities include: the normal day-to-day operations, preventive maintenance, field engineering, water quality monitoring, troubleshooting, emergency response, cross-connection control, implementation of improvements, budget formulation, response to complaints and public/press contact. A reference which the Primacy Agency may utilize in developing the outline is "Water Utility Management Practices" published by AWWA.

3. CRITERIA FOR SYSTEMS NOT FILTERING

The provisions of the Surface Water Treatment Rule (SWTR) require that filtration must be included in the treatment train unless certain criteria are met. These criteria are described in this chapter. They include:

Source Water Quality Conditions

1. Coliform concentrations (total or fecal).
2. Turbidity levels.

Disinfection Criteria

1. Level of disinfection.
2. Point of entry disinfection.
3. Distribution system disinfection.
4. Disinfection redundancy or automatic shutoff.

Site-Specific Criteria

1. Watershed control program.
2. On-site inspections.
3. No waterborne disease outbreaks.
4. Complies with the total coliform MCL.
5. Complies with the Total Trihalomethane (TTHM) regulation. Currently this only applies to systems serving more than 10,000 people.

The purpose of this section is to provide guidance to the Primacy Agency for determining compliance with these provisions.

3.1 Source Water Quality Criteria

The first step in determining if filtration is required for a given surface water supply is to determine whether the supply meets the source water quality criteria as specified in the SWTR. If the supply does not meet the source water quality criteria, changes in operation to meet the site-specific criteria may improve the water quality so that the source

criteria will be met. However, if the Primacy Agency believes that the source water quality criteria and/or the site-specific criteria cannot be met, or that filtration is appropriate regardless, the Primacy Agency may require the installation of filtration without a complete evaluation to determine whether the system meets all the criteria required to avoid filtration.

Sampling Location

The SWTR requires that source water samples be collected at a location just prior to the "point of disinfectant application," i.e., where the water is disinfected and no longer subject to surface runoff. For example, a system which has multiple reservoirs in series, where each of the reservoirs has previously been disinfected and receives surface runoff, must take the raw water sample(s) just prior to the point of disinfection or disinfection sequences used for calculating the CT [disinfectant residual (mg/L) x contact time (min.)]. Disinfected water in reservoirs receiving surface runoff cannot be counted toward CT credit. It is also not appropriate for systems to monitor the source water after the "point of disinfectant application" even if disinfection from this point is not used for calculating CT credit.

3.1.1 Coliform Concentrations: The SWTR states that, to avoid filtration, a system must demonstrate that either the fecal coliform concentration is less than 20/100 ml or the total coliform concentration is less than 100/100 ml in the water prior to the point of disinfectant application in 90 percent of the samples taken during the six previous months. Where monitoring for both parameters has been or is conducted, the rule requires that only the fecal coliform limit be met. However, EPA recommends that the analytical results for both total coliforms and fecal coliforms be reported. In addition, if the turbidity of a surface water source is greater than 5 NTU and the surface source is blended with a ground water source to reduce the turbidity, EPA recommends that the high turbidity water prior to blending meet the fecal coliform source water quality criteria.

Elevated coliform levels in surface water indicate higher probabilities of fecal contamination, some of which could be protected from exposure to disinfection by embodiment in particulate matter. Blending of

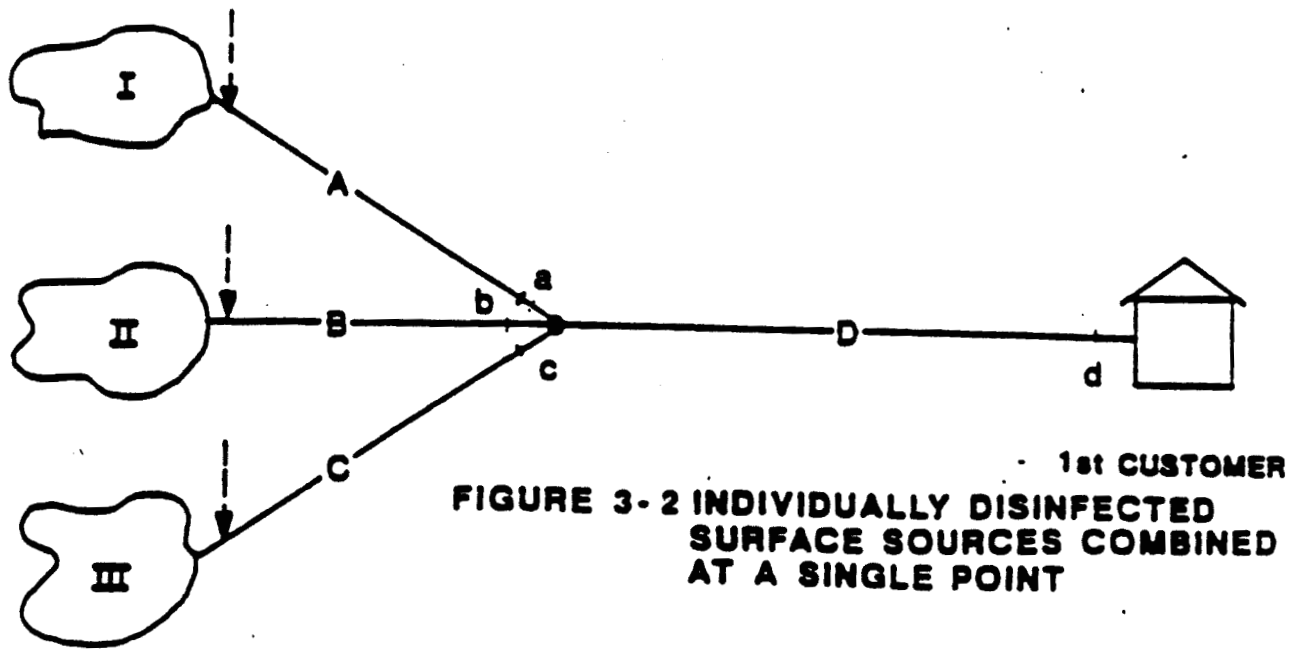

FIGURE 3-2 INDIVIDUALLY DISINFECTED SURFACE SOURCES COMBINED AT A SINGLE POINT

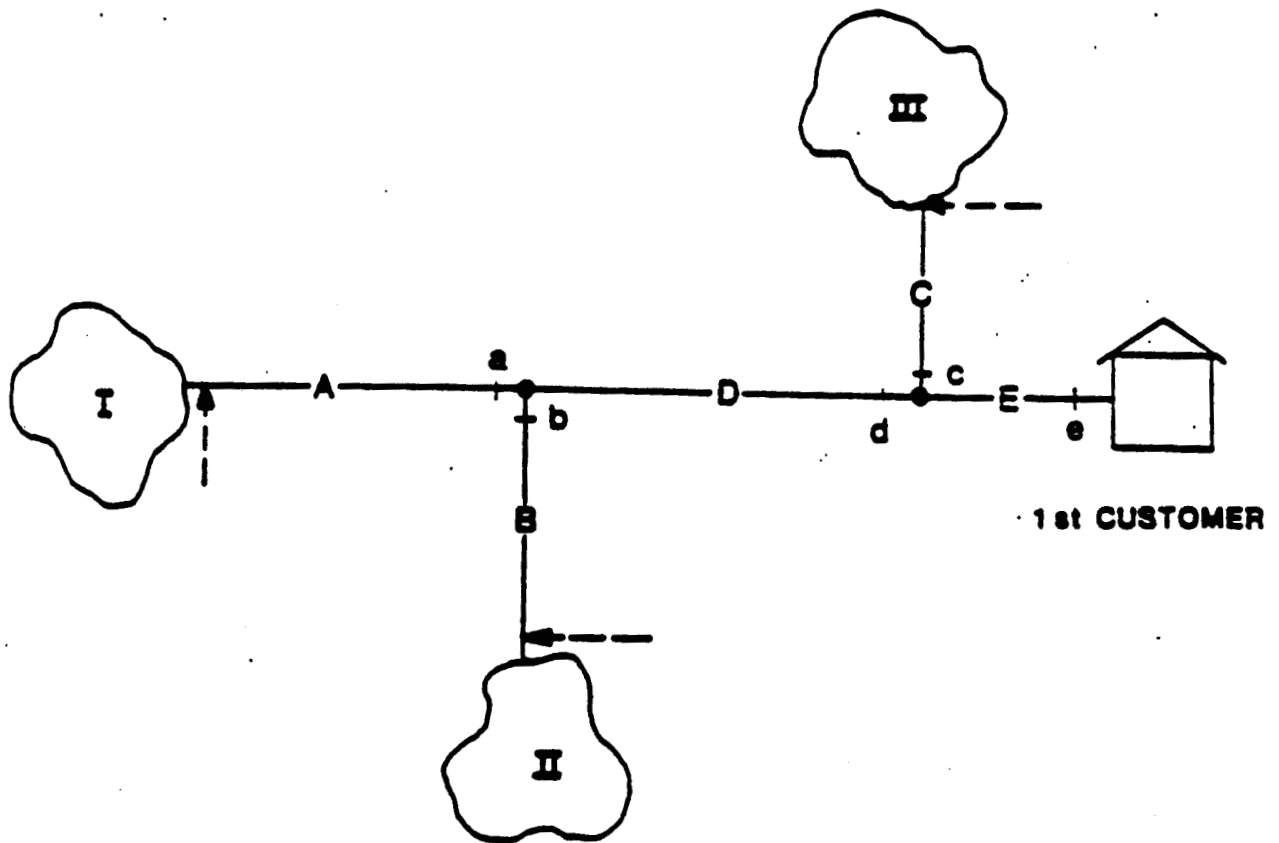

FIGURE 3-3 MULTIPLE COMBINATION POINTS FOR INDIVIDUALLY DISINFECTED SURFACE SOURCES

- ← DISINFECTANT APPLICATION
- COMBINATION POINT
- SAMPLING POINTS

the surface water with ground water to reduce coliform levels may obscure the indication of such possible effects. Thus, EPA does not recommend blending to reduce coliform levels in the source water. Furthermore, EPA does not recommend blending to reduce turbidity levels in cases where elevated fecal contamination may be masked.

Ongoing monitoring is required to ensure that these requirements are continually met. The samples may be analyzed using either the multiple tube fermentation method or the membrane filter test (MF) as described in the 16th Edition of Standard Methods.

Sampling Frequency

Minimum sampling frequencies are as follows:

<u>Population Served</u>	<u>Coliform Samples/Week</u>
≤500	1
501-3,300	2
3,301-10,000	3
10,001-25,000	4
>25,000	5

Grab samples must be taken on different days. In addition, one sample must be taken every day during which the turbidity exceeds 1 NTU, unless the Primacy Agency determines that the system, for logistical reasons outside the system's control, cannot have the sample analyzed within 30 hours of collection. If taken, these samples count towards the weekly sampling requirement. Also, under the Total Coliform Rule, systems must take one coliform sample in the distribution system near the first service connection within 24 hours after a source water turbidity measurement exceeds 1 NTU. This measurement must be included in the total coliform compliance determination. The purpose of these requirements is to ensure that the monitoring occurs during worst case conditions.

The initial evaluation of the source water quality is based on the data from the previous 6 months. After the initial evaluation, systems must continue to conduct sampling each month to demonstrate compliance with the source water quality criteria on an ongoing basis. If the criterion has not been met, the system must filter.

Use of Historical Data Base

Some systems may already monitor their source water for total and/or fecal coliform concentration. The resulting historical data base may be sufficient for the Primacy Agency to make the initial determination of whether the system meets the source water quality criteria. The historical data base is considered sufficient for making this determination if:

- The raw water sampling location is upstream of the point of disinfectant application as previously defined.
- The monthly samples represent at least the minimum sampling frequency previously mentioned.
- The sampling period covers at least the previous six months.

3.1.2 Turbidity Levels: To avoid filtration, the turbidity of the water prior to disinfection cannot exceed 5 NTU, on an ongoing basis, based on grab samples collected every four hours (or more frequently) that the system is in operation. A system may substitute continuous turbidity monitoring for grab sample monitoring if it validates such measurements for accuracy with grab sample measurements on a regular basis, as specified by the Primacy Agency.¹ If a public water system uses continuous monitoring, it must use turbidity values recorded every four hours (or some shorter regular time interval) to determine whether it meets the turbidity limit for raw water. A system occasionally may exceed the 5 NTU limit and still avoid filtration as long as (a) the Primacy Agency determines that each event occurred because of unusual or unpredictable circumstances and (b) as a result of this event, there have not been more than two such events in the past twelve months the system served water to the public or more than five such events in the past 120 months the system

¹ Validation should be performed at least twice a week based on the procedure outlined in Part 214A in the 16th Edition of Standard Methods. Although the 17th Edition is available, the 16th Edition is that which is referred to in the rule. Improper installation of continuous monitors may allow for air bubbles to enter the monitor resulting in false turbidity spikes. To avoid air bubbles reaching the turbidimeter, the sample tap should be installed below the center line of the pipe and an air release valve may be included on the sample line.

served water to the public. An "event" is defined as a series of consecutive days in which at least one turbidity measurement each day exceeds 5 NTU.

It is important to note that every event, i.e., exceedance of the 5 NTU limit, regardless of whether the system must filter as a consequence, constitutes a violation of a treatment technique requirement. For example, if the turbidity exceeded 5 NTU in at least one measurement each day for three consecutive days, this would constitute one event and one treatment technique violation. If this was the third event in the past 12 months the system served water to the public, or the sixth event in the past 120 months the system had served water to the public, the system would also be required to install filtration. In all cases, the system must inform the Primacy Agency when the turbidity exceeds 5 NTU as soon as possible, but no later than the end of the next business day.

The Primacy Agency should evaluate additional data from the utility to determine the significance of the event with respect to the potential health risk to the community and determine whether a boil water notice is necessary. The additional data may include raw water fecal coliform levels, duration and magnitude of the turbidity excursion, nature of the turbidity (organic or inorganic), disinfectant residual entering the system during the excursion and/or coliform levels in the distribution system following the excursion. Boil water notices are not required under the SWTR, they may be issued at the discretion of the Primacy Agency.

In order to determine if the periods with turbidity greater than 5 NTU are unusual or unpredictable, it is recommended that in addition to the historical turbidity data, the water purveyor should collect and provide to the Primacy Agency current and historical information on flows, reservoir water levels, climatological conditions, and any other information that the Primacy Agency deems relevant. The Primacy Agency will then evaluate this information to determine if the event was unusual or unpredictable. Examples of unusual or unpredictable events include hurricanes, floods and earthquakes. High turbidity events may be avoided by:

- Use of an alternate source which is not a surface water and does not have to meet the requirements of the SWTR.

- Use of an alternate source which is not a surface water and does not have to meet the requirements of the SWTR.
- Use of an alternate source which is a surface water and which does meet the requirements of the SWTR.
- Utilization of stored water to supply the community until the source water quality meets the criteria.

3.2 Disinfection Criteria

3.2.1 Inactivation Requirements

To avoid filtration, a system must demonstrate that it maintains disinfection conditions which inactivate 99.9 percent of Giardia cysts and 99.99 percent of viruses every day of operation except any one day each month. If the disinfection conditions provide less than these inactivations during more than one day of the month, the system is in violation of a treatment technique requirement. If the system incurs such a violation during any two months in the previous 12 months, the system must install filtration, unless one of the violations was caused by unusual and unpredictable circumstances as determined by the Primacy Agency. Systems with three or more violations in the previous 12 months must install filtration regardless of the cause of the violation. To demonstrate adequate inactivations, the system must monitor and record the disinfectant(s) used, disinfectant residual(s), disinfectant contact time(s), pH (for chlorine), and water temperature, and use these data to determine if it is meeting the minimum total inactivation requirements in the rule.

A number of disinfectants are available, including ozone, chlorine, chlorine dioxide and chloramines. The SWTR prescribes CT [C, residual disinfectant concentration (mg/L) x T, contact time (min)] levels for these disinfectants which will achieve different levels of inactivation under various conditions. The disinfectant(s) used to meet the inactivation requirements is identified as the primary disinfectant throughout the remainder of this document.

To determine compliance with the inactivation requirements, a system must calculate the CT value(s) for its disinfection conditions during peak hourly flow once each day that it is delivering water to its customers. For the purpose of calculating CT value, T is the time (in minutes) it

takes the water, during peak hourly flow, to move between the point of disinfectant application and a point where, C, residual disinfectant concentration is measured prior to the first customer. Residual disinfectant concentration is the concentration of the disinfectant (in mg/L) at a point before or at the first customer. Contact time in pipelines must be calculated based on plug flow (i.e., where all water moves homogeneously in time between two points) by dividing the internal volume of the pipeline by the peak hourly flow rate through that pipeline. Contact time within mixing basins, settling basins storage reservoirs, and any other tankage must be determined by tracer studies or an equivalent method as determined by the Primacy Agency. The contact time determined from tracer studies to be used for calculating CT is T_{10} . T_{10} is the detention time corresponding to the time for which 90 percent of the water has been in contact with at least the residual concentration, C. Guidance for determining contact times for basins is provided in Appendix C.

The first customer is the point at which finished water is first consumed. In many cases this will include the treatment plant itself. This definition of first customer pertaining to the point of first consumption assures that the water has received the required disinfection to provide protection from microorganisms for all consumers. Peak hourly flow should be considered as the greatest volume of water passing through the system during any one hour in a consecutive 24 hour period. Thus, it is not meant to be the absolute peak flow occurring at any instant during the day.

Systems with only one point of disinfectant application may determine the total inactivation based on one point of residual measurement prior to the first customer, or on a profile of the residual concentration after the point of disinfectant application. Methods of disinfection measurement are presented in Appendix D. The residual profile and the total inactivation is calculated as follows:

- Measure the disinfectant residual, C, at any number of points within the treatment train.
- Determine the travel time, T, between the point of disinfectant application and the point where C is measured for the first section. For subsequent measurements of "C," T is the

time it takes for water to move from the previous "C" measurement point to this point of measurement.

- Calculate CT for each point of residual measurement (CT_{calc}).
- Determine the inactivation ratio ($CT_{calc}/CT_{99.9}$) for each section.²
- Sum the inactivation ratios for each section, i.e. $C_1T_1/CT_{99.9} + C_2T_2/CT_{99.9} + C_nT_n/CT_{99.9}$ to determine the total inactivation ratio.

If the total inactivation ratio (sum ($CT_{calc}/CT_{99.9}$)) is equal to or greater than 1.0, the system provides greater than 99.9 percent inactivation of Giardia cysts), and the system meets the disinfection performance requirement. Further explanation of CT calculations is presented in Section 3.2.2.

Systems need only calculate one CT (CT_{calc}) each day, for a point at or prior to the first customer; alternatively they have the option of calculating numerous CTs after the point of disinfectant application but prior to the first customer to determine the inactivation ratio. Profiling the residual gives credit for the higher residuals which exist after the disinfectant is applied but before the first customer. Profiling the residual may not be necessary if one CT is calculated (CT_{calc}), and this exceeds the applicable $CT_{99.9}$. In this case, the system is meeting the disinfection performance requirement. For systems with a very low oxidant demand in the water and long contact times, this approach may be the most practical to use.

For systems with multiple points of disinfectant application, such as ozone followed by chlorine, or chlorine applied at two different points in the treatment train, the inactivation ratio of each disinfectant section prior to the first customer is used to determine the total inactivation ratio. The disinfectant residual of each disinfection

² $CT_{99.9}$ is the CT value required to achieve 99.9 percent or 3-log Giardia cyst inactivation for the conditions of pH, temperature and residual concentration for each section. A section is the portion of the system with a measurable contact time between two points of disinfection application or residual monitoring.

section and the corresponding contact time must be measured at some point prior to the subsequent disinfection application point(s) to determine the inactivation ratio for each section, and whether the total inactivation ratio is 1.0 or more. For example, if the first disinfection section provided an inactivation ratio of 2/3 (or 99 percent inactivation) and the second disinfection section provided an inactivation ratio of 1/3 (or 90 percent inactivation), the total inactivation ratio would equal 1.0 ($2/3 + 1/3 = 1$) indicating that 99.9% inactivation was provided and the disinfection requirements are met. Further explanation of the determination of total inactivation provided is contained in Section 3.2.2.

Maintaining Inactivation Level

The SWTR establishes CTs for chlorine, chlorine dioxide, ozone and chloramines which will achieve 3-log inactivations of Giardia cysts and at least 4-log inactivation of viruses. Appendix E presents CTs for these and other log inactivations. A system must demonstrate compliance with the inactivation requirements based on conditions occurring during peak hourly flow. Since a system generally can only identify peak hourly flow after it has occurred, hourly residual measurements during the day are suggested. If the sampling points are remote, or manpower is limited and collection of hourly grab samples is impractical, continuous monitors may be installed. In cases where continuous monitors are impractical, the Primacy Agency may establish an acceptable monitoring program on a case-by-case basis; where possible this should be based on historical flow patterns. Measurements for the hour of peak flow can then be used in calculating CT. The pH (for systems using chlorine) and temperature must be determined daily for each disinfection sequence prior to the first customer.

Since the system's inactivation is determined during peak hourly flow, the disinfectant dosage applied to meet CT requirements may not be necessary during lower flow conditions. Continuing to apply a disinfectant dosage based on the peak hourly flow could possibly result in increased levels of disinfectant by-products, including TTHMs and increased costs. Under lower flow conditions, a higher contact time is available and a lower residual may provide the CT needed to meet the inactivation requirements. The system may therefore choose to adjust the

disinfectant dose with changes in flow. The system should, however, maintain a disinfectant residual which will still provide a 3-log inactivation of Giardia cysts and a 4-log inactivation of viruses at non-peak hourly flows. The system should therefore evaluate the residual needed to provide the required inactivation under different flow conditions and set the dosage accordingly. The following provides an example of maintaining the required inactivation.

Example

A 5 mgd non-filtering system disinfecting with free chlorine at one point of application, has a contact time of 165 minutes during a peak flow of 5 MGD. The flow varies from 1 to 5 MGD. The pH and temperatures of the water are 7 and 5 C, respectively. At a residual of 0.9 mg/L, a CT of 148 mg/L-min is required to meet the disinfection requirements. The CT for 0.9 mg/L residual is determined by straight line interpolation between 0.8 mg/L and 1.0 mg/L residuals. Under lower flow conditions, the available contact time is longer and a lower residual would provide the required disinfection. Based on existing contact time and using the appropriate CT tables (in this case, Table E-2) in Appendix E for a 3-log Giardia cyst inactivation, the required disinfection would be provided by maintaining the following chlorine residuals for the indicated flow:

<u>Flow (MGD)</u>	<u>Contact Time (min)</u>	<u>CT (mg/L-min) Required</u>	<u>Free Chlorine Residual (mg/L)</u>
5	165	148	0.9
4	206	145	0.7
3	275	143	0.6
2	412	139	0.4
1	825	139	0.2

This table indicates the variation of residuals needed for the system to provide the required inactivation. For chlorine, the disinfectant residual cannot be adjusted in direct proportion to the flow because the CT needed for disinfection is dependent upon the residual. Since it is not practical to continuously adjust the residual and, since a disinfection level for a 3-log Giardia cyst inactivation must be maintained under all flow conditions, it is suggested that the flow variation at the utility be divided into ranges and the residual needed at

the higher flow rate of each range be maintained for all flows within the range to ensure the required disinfection. The following flow ranges and residuals are suggested for the system:

<u>Flow Range (MGD)</u>	<u>Free Chlorine Residual (mg/L)</u>
1 - 1.9	0.4
2 - 3.9	0.6
4 - 5	0.9

By maintaining these residuals, the utility is ensuring the provision of the required disinfection while minimizing the disinfectant application, which should result in lower disinfection by-products and costs.

Although these residuals will meet the inactivation requirements, maintaining a residual in the distribution system must also be considered. If no other point of disinfection exists prior to the distribution system, the residual for disinfection must be maintained at a level which will also provide a residual throughout the distribution system. The complete range of flows occurring at the plant should be evaluated for determining the required residual. A utility may establish the residual requirements for as many flow ranges as is practical.

The CTs determined from the daily system data should be compared to the values in the table for the pH and temperature of the water, to determine if the required CT has been achieved. Only the analytical methods prescribed in the SWTR, or otherwise approved by EPA, may be used for measuring disinfectant residuals. Methods prescribed in the SWTR are listed in Appendix D. The Appendix also contains a paper which describes monitoring methods for various disinfectants and conditions.

The Primacy Agency should make periodic checks on its utilities to assure that they are maintaining adequate disinfection at non-peak flow conditions.

Meeting the Inactivation Requirement Using Free Chlorine

When free chlorine is used as a disinfectant, the efficiency of inactivation is influenced by the temperature and pH of the water. Thus, the measurement of the temperature and pH for the determination of the CT is required. The SWTR provides the CT requirements for free chlorine at

various temperatures and pHs which may occur in a source water. These values are presented in Table E-1 through Table E-7 in Appendix E. The basis for these values is discussed in Appendix F. For free chlorine, a 3-log inactivation of Giardia cysts will provide greater than a 4-log inactivation of viruses, thus meeting the SWTR inactivation requirements.

As indicated in Table E-2, a raw water temperature of 5 C, a pH of 7.0, and a residual chlorine concentration of 1.4 mg/L require a CT of 155 mg/L-min to provide a 3-log inactivation of Giardia cysts. Therefore, to meet the inactivation requirement under these conditions with one point of residual measurement, a contact time of 111 minutes $[(155 \text{ mg/L-min}) / (1.4 \text{ mg/L})]$ prior to the first customer would be required.

Meeting the Inactivation Requirement Using Chloramines

Chloramines are a much weaker oxidant than free chlorine, chlorine dioxide and ozone. The CT values for chloramines presented in Table E-12 are based on disinfection studies using preformed chloramines and in vitro excystation of Giardia muris cysts (Rubin, 1988). No safety factor was applied to the laboratory data on which the CT values were based since EPA believes that chloramination, conducted in the field, is more effective than using preformed chloramines.

In the laboratory testing using preformed chloramines, ammonia and chlorine were reacted to form chloramines before the addition of the microorganisms. Under field conditions, chlorine is usually added first followed by ammonia addition further downstream. Also, even after the addition of ammonia, some free chlorine residual may persist for a period of time. Therefore, free chlorine is present for a period of time prior to the formation of chloramines. Since this free chlorine contact time is not duplicated in the laboratory when testing with preformed chloramines, the CT values obtained by such tests may provide conservative values when compared to those CTs actually obtained in the field with chlorine applied before ammonia. Also, other factors such as mixing in the field (versus no mixing in the laboratory) may contribute to disinfection effectiveness. For these reasons, systems using chloramines for disinfection may demonstrate effective disinfection in accordance with the procedure in Appendix G in lieu of meeting the CT values in Appendix E.

If a system uses chloramines and is able to achieve the CT values for 99.9 percent inactivation of Giardia cysts, it is not always appropriate to assume that 99.99 percent or greater inactivation of viruses was also achieved. New data indicate that Hepatitis A virus is more sensitive than Giardia cysts to inactivation by preformed chloramines (Sobsey, 1988). The CT values required to achieve 99.99 percent inactivation of Hepatitis A with preformed chloramines are lower than those needed to achieve 99.9 percent inactivation of Giardia cysts. These data contrast with other data which indicate that rotavirus is more resistant than Giardia cysts to preformed chloramines (Hoff, 1986).³ However, rotavirus is very sensitive to inactivation by free chlorine, much more so than Hepatitis A (Hoff, 1986;⁴ Sobsey, 1988). If chlorine is applied prior to ammonia, the short term presence of free chlorine would be expected to provide at least 99.99 percent inactivation of rotavirus prior to the addition of ammonia and subsequent formation of chloramines. Thus, EPA believes it is appropriate to use Hepatitis A data, in lieu of rotavirus data, as a surrogate for defining minimum CT values for inactivation of viruses by chloramines, under the condition that chlorine is added to the water prior to the addition of ammonia.

A system which achieves a 99.9 percent or greater inactivation of Giardia cysts with chloramines can be considered to achieve at least 99.99 percent inactivation of viruses, provided that chlorine is added to the water prior to the addition of ammonia. Table E-13 provides CT values for achieving different levels of virus inactivation. However, if ammonia is added first, the CT values in the SWTR for achieving 99.9 percent inactivation of Giardia cysts cannot be considered adequate for achieving 99.99 percent inactivation of viruses.

Under such cases of chloramine production, the SWTR requires systems to demonstrate through on-site challenge studies, that the system is

³ CT values in excess of 5,000 are required for a 4-log inactivation of rotavirus by preformed chloramines but no minimum CT values have been determined.

⁴ CT values ranging from 0.025 to 2.2 achieve 99 percent inactivation of rotavirus by free chlorine at pH = 6 -10 and 4 - 5°C (Hoff, 1986).

achieving at least a 4-log inactivation of viruses. Guidance for conducting such studies is given in Appendix G. Once conditions for achieving a 4-log inactivation of viruses has been established, the Primacy Agency should require systems to report their disinfection operating conditions on an ongoing basis. These conditions should verify that the system is operating at CT values in excess of that needed to achieve a 4-log virus inactivation or 3-log Giardia cyst inactivation, whichever is higher.

Meeting the Inactivation Requirement Using Chlorine Dioxide

Under the SWTR, the CT values for the inactivation of Giardia cysts using chlorine dioxide are independent of pH. Under the SWTR the only parameter affecting the CT requirements associated with the use of chlorine dioxide is temperature. Table E-8 in Appendix E presents the chlorine dioxide CT values required for the inactivation of Giardia cysts at different temperatures. The basis for these CT values is discussed in Appendix F. Systems which use chlorine dioxide are not required to measure the pH of the disinfected water for the calculation of CT. For chlorine dioxide, a 3-log inactivation of Giardia cysts will generally result in greater than a 4-log virus inactivation, and assure meeting the SWTR inactivation requirements. However, for chlorine dioxide, unlike chlorine where this relationship always holds true, at certain temperatures, the 4-log virus CTs may be higher than the 3-log Giardia cyst CTs.

The Primacy Agency may allow lower CT values than those specified in the SWTR for individual systems based on information provided by the system. Protocols for demonstrating effective disinfection at lower CT values is provided in Appendix G.

As indicated in Tables E-8 and E-9, the CT requirements for chlorine dioxide are substantially lower than those required for free chlorine. However, chlorine dioxide is not as stable as free chlorine or chloramines in a water system and may not be capable of providing the required disinfectant residual throughout the distribution system. In addition, out of concern for toxicological effects, EPA's current guideline is that the sum of the chlorine dioxide, chlorate and chlorite residuals, be less than 1.0 mg/L at all consumer taps. This guideline may be lowered as more health effects data become available. These concerns further reduce the

feasibility of using chlorine dioxide as a secondary disinfectant for distribution systems. Therefore, the use of chlorine dioxide as a primary disinfectant may result in the need for the application of a secondary disinfectant, such as chlorine or chloramines, that will persist in the distribution system and provide the required residual protection.

Meeting the Inactivation Requirement Using Ozone

Another disinfectant to inactivate Giardia cysts and viruses is ozone. As with chlorine dioxide, under the SWTR, the CT values for ozone are independent of pH. Tables E-10 and E-11 present the CT requirements for ozone at different source water temperatures. The basis for the CT values for ozone is given in Appendix F. As for free chlorine, a 3-log Giardia cyst inactivation with ozone will result in greater than a 4-log virus inactivation. Unlike chlorine, for cases where only a 1-log or lower Giardia inactivation is needed with ozone, the CT values for virus inactivation may be higher than the CT for Giardia. The Primacy Agency may allow lower CT values for individual systems based on information provided by the system that demonstrates that CT values lower than those specified in the rule achieve the same inactivation efficiencies (see Appendix G).

Ozone is extremely reactive and dissipates quickly after application. Therefore, a residual⁵ can only be expected to persist a short time

⁵ The residual must be measured using the Indigo Trisulfonate Method (Bader & Hoigne, 1981) or automated methods which are calibrated in reference to the results obtained by the Indigo Trisulfonate method, on a regular basis as determined by the Primacy Agency. The Indigo Trisulfonate method is included in the 17th Edition of Standard Methods. This method is preferable to current standard methods because of the selectivity of the Indigo Trisulfonate indicator in the presence of most interferences found in ozonated waters. The ozone degrades an acidic solution of indigo trisulfonate in a 1:1 proportion. The decrease in absorbance is linear with increasing ozone concentrations over a wide range. Malonic acid can be added to block interference from chlorine. Interference from permanganate, produced by the ozonation of manganese, is corrected by running a blank in which ozone is destroyed prior to addition of the indigo reagent. The samples can be analyzed using a spectrophotometer at a 600 nm wavelength which can detect residuals as low as 2 ug/L or a visual color comparison method which can measure down to 10 ug/L ozone. Although currently available monitoring probes do not use the Indigo Trisulfonate Method, they can

after application. In addition, the application of ozone to water is dependent on mass transfer. For these reasons, the method of CT determination used for the other disinfectants is impractical for ozone. The CT_{calc} must be determined for the ozone contactor alone. The contactor will have some portions where the ozone is applied and other portions of the contactor where ozone is no longer applied, which are referred to as the reactive flow chambers.

For many ozone contactors, the residual in the contactor will vary in accordance with the method and rate of application, the residual will be nonuniform and is likely to be zero in a portion of the contactor. As previously indicated, the CT value is based on the presence of a known residual during a specific contact time. Thus disinfection credit is only provided for the time when a residual is present. Besides the nonuniformity of the residual, monitoring the residual will be difficult because of the ozone's high reactivity and the closed design of the contactors.

In addition to the difficulty in determining the ozone residual for the CT calculation, the contact time will vary between basins depending on their flow configuration. Several types of devices are available for adding ozone to water including porous diffusers, submerged turbines, injector, packed towers and static mixers. Each type of device can be used in either single or multiple chamber contactors. The flow through a single chamber turbine contactor will approximate a completely mixed unit, while flow through a single chamber diffused contactor, or a multiple chamber diffused contactor, will more closely represent plug flow. This variation in flow in different contactors makes the use of T_{10} inappropriate for some contactors.

The differences between ozone contactors and other disinfection systems resulted in the development of several approaches for determining the inactivation provided by ozone, including:

- Evaluation of C and T
- Segregated Flow Analysis (SFA)
- Continuously Stirred Tank Reactor (CSTR)
- Site Specific Evaluation

be calibrated via this method.

The method which is appropriate for a particular system will depend on system configuration and the required level of inactivation. Another significant difference is that ozone may be applied to provide only a portion of the overall 3-log Giardia cyst and 4-log virus inactivation with the remainder of the inactivation provided by another disinfectant. Appendix O provides details for selecting the appropriate method of evaluation for specific conditions.

The evaluation of C and T involves separate determination of the ozone residual concentration, C, and the contact time, T, in the contactor. C can be determined for individual chambers of a contactor based on the residual measured at several points throughout the chamber, or at the exit of the chamber. The T value can be determined through a tracer study or an equivalent method as approved by the Primacy Agency with air or oxygen applied during testing, using the same feed gas rate as used during operation. Appendix O provides details for the CT approach.

SFA is based on the results of a tracer study used in conjunction with the measured ozone residual to determine the survival of microorganisms exiting the contactor. The survival corresponds to a certain inactivation. Guidelines for this approach are included in Appendix O.

The CSTR approach is applicable for contactors which have a high degree of mixing. Experience has shown that for contactors such as turbine units, the ozone residual is generally uniform throughout the contactor. The ozone residual measured at the exit of the contactor is used in an equation for CSTRs to determine the inactivation provided. Appendix O provides details for conducting CSTR analysis.

Site specific evaluations may include:

- Measurement of an observable parameter to correlate with C
- Mathematical model for disinfection efficiency
- Microbial indicator studies for disinfection efficiency

to more closely determine the inactivation provided in a particular system. Appendix O provides details for applying site specific evaluations.

Summary

Many systems which do not provide filtration will have difficulty in providing the contact time necessary to satisfy the inactivation requirements prior to the first customer. For example, a system using free chlorine at a water temperature of 5 C, a pH of 7.0 and a chlorine residual of 1.4 mg/L would require 111 minutes of contact time to meet the inactivation requirement. Potential options for these systems include:

- Installation of storage facilities to provide the required contact time under maximum flow conditions.
- Use of an alternate primary disinfectant such as ozone or chlorine dioxide which has CT values lower than those required for free chlorine for the required inactivation.

For some systems, the difficulty in obtaining the required inactivation may only be a seasonal problem. A system that has raw water temperatures which reach 20 C during the summer months at a pH of 7.0, may have sufficient contact time to meet the CT of 56 mg/L-min (Table E-5) at a chlorine concentration of 1 mg/L. However, assuming the same pH and chlorine concentration, it may not have sufficient contact time to meet the CT requirement at 5 C, 149 mg/L-min (Table E-2), or at 0.5 C, 210 mg/L-min (Table E-1). Under those conditions, a system could choose to use ozone or chlorine dioxide on a seasonal basis, since they are stronger disinfectants requiring a shorter contact time.

As indicated in Table E-12, the CT values for chloramines may be impractical to attain for most systems. Systems which currently utilize chloramines as a primary disinfectant may need to use either free chlorine, chlorine dioxide or ozone in order to provide the required disinfection. However, systems using chloramines as a primary disinfectant may chose to demonstrate the adequacy of the disinfection. Appendix G presents a method for making this demonstration.

Meeting the Inactivation Requirement Using Alternate Disinfectants

For systems using disinfectants other than chlorine, chloramines, chlorine dioxide, or ozone, the effectiveness of the disinfectant can be demonstrated using the protocol contained in Appendix G. The protocol in Appendix G.3 for batch testing should be followed for any disinfectant

which can be prepared in an aqueous solution and will be stable throughout the testing. For disinfectants which are not stable, the pilot study protocol outlined in Appendix G.4 should be followed.

3.2.2 Determination of Overall Inactivation for Residual Profile, Multiple Disinfectants and Multiple Sources

For systems which apply disinfectant(s) at more than one point, or choose to profile the residual from one point of application, the total inactivation is the sum of the inactivation ratios between each of the points of disinfection or between each of the residual monitoring points, respectively. The portion of the system with a measurable contact time between two points of disinfection application or residual monitoring will be referred to as a section. The calculated CT (CT_{calc}) for each section is determined daily.

The CT needed to fulfill the disinfection requirements is $CT_{99.9}$, corresponding to a 3-log inactivation of Giardia cysts and greater than or equal to a 4-log inactivation of viruses (except for chloramines and sometimes chlorine dioxide as explained in Section 3.2.1). The inactivation ratio for each section is represented by $CT_{calc}/CT_{99.9}$, as explained in Section 3.2.1, and indicates the portion of the required inactivation provided by the section. The sum of the inactivation ratios from each section can be used to determine the overall level of disinfection provided. Assuming inactivation is a first order reaction, the inactivation ratio corresponds to log and percent inactivations as follows:

$CT_{calc}/CT_{99.9}$		<u>Log Inactivation</u>		<u>Percent Inactivation</u>
0.17	=	0.5 log	=	68 %
0.33	=	1 log	=	90%
0.50	=	1.5 log	=	96.8%
0.67	=	2 log	=	99%
0.83	=	2.5 log	=	99.7%
1.00	=	3 log	=	99.9%
1.33	=	4 log	=	99.99%

$CT_{99.9}$ can be determined for each section by referring to Tables E-1 through E-13 in Appendix E, using the pH (when chlorine is the disinfectant) and temperatures of the water for the respective sections. These tables present the log inactivation of Giardia cysts and viruses achieved by CTs at various water temperatures and pHs.

Log inactivations are additive, so:

$$0.5 \text{ Log} + 1.0 \text{ Log} = 1.5 \text{ Log or}$$

$$0.17CT_{99.9} + 0.33CT_{99.9} = 0.5CT_{99.9}$$

If the sum of the inactivation ratios is greater than or equal to one, the required 3-log inactivation of Giardia cysts has been achieved. An inactivation ratio of at least 1.0 is needed to demonstrate compliance with the Giardia cyst inactivation requirements for unfiltered systems.

The total log inactivation can be determined by multiplying the sum of the inactivation ratios (sum $(CT_{calc}/CT_{99.9})$), by three. The total log inactivation can be determined in this way because $CT_{99.9}$ is equivalent to a 3-log inactivation. The total percent inactivation can be determined as follows:

$$y = \frac{100 - 100}{10^x} \quad \text{Equation (1)}$$

where: y = % inactivation

x = log inactivation

For example:

$$x = 3.0 \text{ log inactivation}$$

$$y = 100 - \frac{100}{10^{3.0}} = 99.9 \text{ \% inactivation}$$

As explained in Section 3.2.1, the CT_{calc} determined for each disinfection section is the product of the disinfectant residual in mg/L and the detention time in minutes through the section at peak hourly flow. However, for many water systems, peak hourly flow will not necessarily occur simultaneously in all sections. The extent to which the occurrence of peak hourly flow will vary between sections of the system depends on

the characteristics of an individual system including its size, storage capacity within the distribution system, the number of sources, and hydraulic capacities between different sections. In order to simplify the determination of peak hourly flow for the system, it should be taken as peak hourly flow in the last section of the system prior to the first customer.

The CT values for all the sections should be calculated for the flow and the residuals occurring during the hour of peak flow in the last section. The most accurate way to determine the flow in a particular section is through the use of a flow meter. However, some sections of the system may not have a flow meter. The following guidelines can be used to determine the flow to be used in calculating CT:

- For sections which do not have meters, the flow should be assumed to be the higher of the two flows occurring in the closest upstream and downstream sections with meters.
- In cases where a section contains a pipeline and a basin with the flow meter located prior to the basin, the metered flow does not represent the discharge rate of the basin. The difference in inlet and discharge rates from a basin will impact the water level in the basin. As explained in Appendix C, falling water levels will result in lower T_{10} values.
 - To assure that the detention time of a basin is not overestimated, the discharge flow from a basin should be used in lieu of the influent flow, unless the influent flow is higher.
 - To estimate the discharge flow from a basin the closest flow meter downstream of the basin should be used.

The following example presents the determination of the total percent inactivation for multiple points of disinfection, with variation in flow between sections.

Example

A community of 6,000 people obtains its water supply from a lake which is 10 miles from the city limits. Two 0.2 MG storage tanks are located along the 12-inch transmission line to the city. The water is disinfected with chlorine dioxide at the exit from the lake and with chlorine at the discharge from the first and second storage tanks. The

average water demand of the community is 1 MGD with a peak hourly demand of approximately 2 MGD. For the calculations of the overall percent inactivation, the supply system is divided into three sections as shown on Figure 3-1.

Section 1 - from the lake to the discharge from the first storage tank,

Section 2 - from the discharge from the first storage tank to the discharge from the second tank

Section 3 - from the discharge of the second storage tank to the first customer

The overall inactivation is computed daily for the peak hourly flow conditions. Sections 1 and 3 contain flow meters to monitor the water being withdrawn from the lake and the water being delivered to the distribution system as shown on Figure 3-1. On the day of this example calculation, the peak hourly flow in section 3 was 2 MGD. During this hour, water was being withdrawn from the lake at a rate of 1.5 mgd. Considering the placement of flow meters, the flow of 2 mgd measured in section 3 should be used for calculating CT for that section. Since section 2 does not have a flow meter, the meter in section 3 serves as a measure of the discharge from storage tank 2 and should be the flow used in the calculation of CT for section 2. The flow meter in section 1 records the flow through the transmission main which should be used in the calculation of CT for the pipeline. However, this meter does not represent the discharge from storage tank 1. Since the water is being pumped to the distribution system at a higher rate than the flow entering storage tank 1, the flow of 2 mgd measured in section 3 should be used for calculating the CT for storage tank 1.

The pH, temperature and disinfectant residual of the water were measured at the end of each section just prior to the next point of disinfection and the first customer during the hour of peak flow. The water travels through the 12-inch transmission main at 177 ft/min at

1.5 MGD.⁶ The detention times of the storage tanks were read off the T₁₀ vs. Q plots generated from tracer studies conducted on the storage tanks (see Appendix C). The data for the inactivation calculation are as follows:

	<u>Section 1</u>	<u>Section 2</u>	<u>Section 3</u>
length of pipe (ft)	15,840	26,400	10,560
flow (mgd)			
pipe	1.5	2.0	2.0
tank	2.0	2.0	
contact time (min)			
pipe	89	111	45
tank	116	114	0
total	205	225	45
disinfectant	chlorine dioxide	chlorine	chlorine
residual (mg/L)	0.1	0.2	0.4
temperature (C)	5	5	5
pH	8	8	8

This information is then used in conjunction with the CT_{99.9} values in Appendix E to determine the (CT_{calc}/CT_{99.9}) in each section as follows:

Section 1 - Chlorine dioxide

$$CT_{calc} = 0.1 \text{ mg/L} \times 105 \text{ minutes} = 20.5 \text{ mg/L-min}$$

From Table E-8 at a temperature of 5 C and pH = 8, CT_{99.9} is 26 mg/L-min

$$CT_{calc}/CT_{99.9} = \frac{20.5 \text{ mg/L-min}}{26 \text{ mg/L-min}} = 0.79$$

Section 2 - Chlorine

$$CT_{calc} = 0.2 \text{ mg/L} \times 225 \text{ minutes} = 45 \text{ mg/L-min}$$

From Table E-2 at a temperature of 5 C and pH = 8, CT_{99.9} is 198 mg/L-min

$$CT_{calc}/CT_{99.9} = \frac{45 \text{ mg/L-min}}{198 \text{ mg/L-min}} = 0.23$$

$$^6 \quad \frac{Q}{A} = \frac{1.5 \times 10^6 \text{ gal/day} \times \frac{1 \text{ ft}^3}{7.48 \text{ gal}} \times \frac{\text{day}}{1440 \text{ min}}}{\frac{1 \text{ ft}^2}{4}} = 177 \text{ ft/min}$$

Section 3 - Chlorine

$$CT_{calc} = 0.4 \text{ mg/L-min} \times 45 \text{ min} = 18 \text{ mg/L-min}$$

From Table E-2 at a temperature of 5 C and pH = 8,
CT_{99.9} is 198 mg/L-min

$$CT_{calc}/CT_{99.9} = \frac{18 \text{ mg/L-min}}{198 \text{ mg/L-min}} = 0.09$$

The sum of CT_{calc}/CT_{99.9} is equal to 1.11, which is greater than 1, therefore, the system meets the requirements of providing a 3-log inactivation of Giardia cysts. The log inactivation provided is:

$$x = 3 \times \frac{CT_{calc}}{CT_{99.9}} = 3 \times 1.11 = 3.33$$

The percent inactivation can be determined using equation 1.

$$y = 100 - \frac{100}{10^{3.33}} = 100 - \frac{100}{2,138} = 100 - 0.05 = 99.95\% \text{ inactivation}$$

The system meets the requirement of providing a 99.9 percent inactivation of Giardia cysts.

The SWTR also requires that the public be provided with protection from Legionella as well as Giardia cysts and viruses. Inactivation levels have not been set for Legionella because the required inactivation of Giardia cysts will provide protection from Legionella.⁷ However, this level of disinfection cannot assure that all Legionella will be inactivated and that no recontamination or regrowth in recirculating hot water systems of buildings or cooling systems will occur. Appendix B provides

⁷ Kuchta et al. (1983) reported a maximum CT requirement of 22.5 for a 99 percent inactivation of Legionella in a 21 C tap water at a pH of 7.6-8.0 when using free chlorine. Using first order kinetics, a 99.9 percent inactivation requires a CT of 33.8. Table A-5 presents the CTs needed for free chlorine to achieve a 99.9 percent inactivation of Giardia cysts at 20 C. This table indicates that the CT required for a 3-log inactivation of Giardia at the temperature and pH of the Legionella test ranges from 67 to 108 depending on chlorine residual. These CT's are two to three times higher than that which is needed to achieve a 3 log inactivation of Legionella.

guidance for monitoring and treatment to control Legionella in institutional systems.

The above discussion pertains to a system with one source with sequential disinfection. Another system may blend more than one source, and disinfect one or more of the sources independently prior to blending. System conditions which may exist include:

- All the sources are combined at one point prior to supplying the community but one or more of the sources are disinfected prior to being combined, as shown on Figure 3-2.
- Each source is disinfected individually and enters the distribution system at a different point, as shown on Figure 3-3.

For all systems combining sources, the first step in determining the CT should be to determine the CT_{calc} provided from the point of blending closest to the first customer using the contact time and residual at peak hourly flow for that portion of the distribution system. This corresponds to section D on Figure 3-2 and section E on Figure 3-3. If the CT_{calc} for section D or E provides the required inactivation, no additional CT credit is needed and no further evaluation is required. However, if the CT for section D or E is not sufficient to achieve the required inactivation, then the inactivation ratio $(CT_{calc})/(CT_{99.9})$ should be determined for each section to determine the overall inactivation provided for each source. The total inactivation must be greater than or equal to one for all sources in order to comply with the requirements for 3-log inactivation of Giardia cysts.

On Figure 3-2, sections A, B, C and D contain sampling points a, b, c and d, respectively. The sum of the inactivation ratios for sections A+D, B+D and C+D must each be greater than or equal to one for the disinfection requirements to be met.

The total inactivation for each source on Figure 3-2 should be determined as follows:

Source 1

- Determine CT_{calc} for sections A and D based on the residual measurements at sample points a and d, and the travel time

through each section under peak hourly flow conditions for the respective section.

- Determine $CT_{99.9}$ for the pH and temperature conditions in each section using the tables in Appendix E
- Calculate the inactivation ratios ($CT_{calc}/CT_{99.9}$) for sections A and D.
- Calculate the sum of the inactivation ratios for sections A and D to determine the total inactivation for source I.
- If the sum of the inactivation ratios is greater than or equal to 1.0, the system has provided the required 3-log Giardia cyst inactivation.

Source II

- Determine CT_{calc} for section B based on the residual measured at sample point b and the travel time through the section under peak hourly flow conditions.
- Determine $CT_{99.9}$ for section B for the pH and temperature conditions in the section using the appropriate tables in Appendix E.
- Calculate the inactivation ratio ($CT_{calc}/CT_{99.9}$) for section B.
- Add the inactivation ratios for sections B and D to determine the total inactivation for source II.
- If the sum of the inactivation ratios is greater than or equal to 1.0, the system has provided the required 3-log Giardia cyst inactivation for the source.

Source III

- Determine CT_{calc} for section C based on the residual measured at sample point c and the travel time through the section under peak hourly flow conditions.
- Determine $CT_{99.9}$ for section C for the pH and temperature conditions in the section using the appropriate tables in Appendix E.
- Calculate the inactivation ratio ($CT_{calc}/CT_{99.9}$) for section C.
- Add the inactivation ratios for sections C and D to determine the total inactivation for Source III.

- If the sum of the inactivation ratios is greater than or equal to 1.0, the system has provided the required 3-log Giardia cyst inactivation for the source.

The determination of the total inactivation for each source may require more calculations for systems such as that on Figure 3-3 than on Figure 3-2. On Figure 3-3 sections A, B, C, D, and E contain sampling points a, b, c, d, and e respectively. In order to minimize the calculations needed, the determination of the total inactivation should begin with the source closest to the first customer.

The total inactivation for each source on Figure 3-3 should be determined as follows:

Source III

- Determine CT_{calc} for sections C and E based on the residual measurement at sample points c and e and the detention time in each section under peak hourly flow conditions for the respective section.
- Determine $CT_{99.9}$ for the pH and temperature conditions in each section using the tables in Appendix E.
- Calculate the inactivation ratios ($CT_{calc}/CT_{99.9}$) for sections C and E.
- Calculate the sum of the inactivation ratios for sections C and E to determine the total inactivation for source III.
- If the sum of the inactivation ratios is greater than or equal to 1.0, the system has provided the required 3-log Giardia cyst inactivation for source III.

Source II

- Determine CT_{calc} for section D based on the residual measured at sample point d and the detention time through the section under peak hourly flow conditions.
- Determine $CT_{99.9}$ for section D for the pH and temperature conditions in the section using the appropriate tables in Appendix E.
- Calculate the inactivation ratio ($CT_{calc}/CT_{99.9}$) for section D.
- Add the inactivation ratios for sections D and E to determine the overall inactivation.

- If the sum of the inactivation ratios is greater than or equal to 1.0, the system has provided the required 3-log Giardia cyst inactivation for source II, as well as source I since the water from each of these sources are combined prior to sections D and E.
- If the total inactivation ratio for sections D and E is less than 1.0, additional calculations are needed. Proceed as follows for source II.
- Determine CT_{calc} for section B based on the residual measured at sample point b and the detention time through the section under peak hourly flow conditions.
- Determine $CT_{99.9}$ for section B for the pH and temperature conditions in the section using the appropriate tables in Appendix E.
- Calculate the inactivation ratio ($CT_{calc}/CT_{99.9}$) for section B.
- Add the inactivation ratios for sections B, D and E to determine the total inactivation for source II.
- If the sum of the inactivation ratios is greater than or equal to 1.0, the system has provided the required 3-log Giardia cyst inactivation for the source.

Source I

As noted in the determination of the inactivation provided for source II, if the sum of the inactivation ratios for sections D and E is greater than or equal to 1.0, the system has provided the required 3-log Giardia cyst inactivation. However, if this sum is less than 1.0 additional calculations will be needed to determine the overall inactivation provided for source I. The calculations are as follows:

Source I

- Determine CT_{calc} for section A based on the residual measured at sample point a and the detention time in the section under peak hourly flow conditions.
- Determine $CT_{99.9}$ for section A for the pH and temperature conditions in the section using the appropriate tables in Appendix E.
- Calculate the inactivation ratio ($CT_{calc}/CT_{99.9}$) for section A.
- Add the inactivation ratios for sections A, D, and E to determine the total inactivation for source I.

- If the sum of the inactivation ratios is greater than or equal to 1.0, the system has provided the required 3-log Giardia cyst inactivation for the source.

3.2.3 Demonstration of Maintaining a Residual

The SWTR establishes two requirements concerning the maintenance of a residual. The first requirement is to maintain a minimum residual of 0.2 mg/L entering the distribution system. The second is to maintain a detectable residual throughout the distribution system. The disinfectant used to meet these requirements is identified as the secondary disinfectant throughout the remainder of this document. These requirements are further explained in the following sections.

Maintaining a Residual Entering the Distribution System

To avoid filtration, the disinfectant residual in water entering the distribution system cannot be less than 0.2 mg/l for more than four hours, with one exception noted below. Systems serving more than 3,300 persons must monitor continuously. If there is a failure in the continuous monitoring equipment, the system may substitute grab sampling every four hours for up to five working days following the failure of the equipment. Systems serving 3,300 or fewer people may monitor continuously or take grab samples at the frequencies prescribed below:

<u>System Size by Population</u>	<u>Samples/day*</u>
≤500	1
501-1,000	2
1,001-2,500	3
2,501-3,300	4

*Samples cannot be taken at the same time.

The sampling intervals are subject to Primacy Agency review and approval.

If at any time the residual disinfectant concentration falls below 0.2 mg/l in a system using grab sample monitoring, the system must continue to take a grab sample every four hours until the residual disinfectant concentration is equal to or greater than 0.2 mg/l. For all systems, if the residual concentration is not restored to at least 0.2 mg/l within four hours after a value of less than 0.2 mg/l is observed, the system is

in violation of a treatment technique requirement, and must install filtration. However, if the Primacy Agency finds that the exceedance was caused by an unusual and unpredictable circumstance, the Primacy Agency may choose not to require filtration. EPA expects Primacy Agencies to use this provision sparingly; it is intended to encompass catastrophic events, not infrequent large storm events. In addition, any time the residual concentration falls below 0.2 mg/l, the system must notify the Primacy Agency. Notification must occur as soon as possible, but no later than the end of the next business day. The system also must notify the Primacy Agency by the end of the next business day whether or not the residual was restored within four hours.

Failure of a monitoring or reporting requirement does not trigger a requirement to filter although they are violations.

Maintaining a Residual Within the System

To avoid filtration, the disinfectant residual in the distribution system cannot be undetectable in more than five percent of the samples in a month, for any two consecutive months that the system serves water to the public. Systems may measure HPC instead of disinfectant residual. Sites with HPC concentrations of less than or equal to 500/ml are considered equivalent to sites with detectable residuals for the purpose of determining compliance. Public water systems must monitor for the presence of a disinfectant residual (or HPC levels) at the same frequency and locations as total coliform measurements taken pursuant to the Total Coliform Rule. However, if the Primacy Agency determines, based on site-specific considerations, that a system has no means for having a sample transported and analyzed for HPC by a certified laboratory within the requisite time and temperature conditions (Method 907, APHA, 1985), but that the system is providing adequate disinfection in the distribution system, this requirements does not apply to that system.

For systems which use both surface and ground water sources, the Primacy Agency may allow the system to take disinfectant residual or HPC samples at points other than the total coliform sampling locations if it determines that such points are more representative of treated (disinfected) water quality within the distribution system.

Disinfectant residual can be measured as total chlorine, free chlorine, combined chlorine or chlorine dioxide (or HPC level). The SWTR lists the approved analytical methods for these analyses. For example, several test methods can be used to test for chlorine residual in the water, including amperometric titration, DPD colorimetric, DPD ferrous titrimetric method and iodometric method, as described in the 16th Edition of Standard Methods.⁸ Appendix D provides a review and summary of available techniques to measure disinfectant residuals.

If a system fails to maintain a detectable disinfectant residual or an HPC level of less than or equal to 500/ml in more than 5 percent of the samples during a month, for any two consecutive months the system serves water to the public, the system is in violation of a treatment technique requirement. In addition, this system must install filtration unless the Primacy Agency determines that the violation was not due to a deficiency in treatment of the source water (e.g., the violation was due to a deficiency in the distribution system, such as cross-connection contamination or failure in the pipeline).

The absence of a detectable disinfectant residual in the distribution system may be due to a number of factors, including:

- Insufficient chlorine applied at the treatment plant
- Interruption of chlorination
- A change in chlorine demand in either the source water or the distribution system
- Long standing times and/or, long transmission distances

Available options to correct the problem of low disinfectant residuals in distribution systems include:

- Routine flushing

⁸ Also, portable test kits are available which can be used in the field to detect residual upon the approval of the Primacy Agency. These kits may employ titration or colorimetric test methods. The colorimetric kits employ either a visual detection of a residual through the use of a color wheel, or the detection of the residual through the use of a hand held spectrophotometer.

- Increasing disinfectant doses at the plant
- Cleaning of the pipes (either mechanically by pigging or by the addition of chemicals to dissolve the deposits) in the distribution system to remove accumulated debris which may be exerting a disinfectant demand;
- Flushing and disinfection of the portions of the distribution system in which a residual is not maintained; or
- Installation of satellite disinfection feed facilities within the distribution system.

For systems unable to maintain a residual, the Primacy Agency may determine that it is not feasible for the system to monitor HPC and judge that disinfection is adequate based on site-specific conditions.

Additional information on maintaining a residual in the system is available in the AWWA Manual of Water Supply Practices and Water Chlorination Principles and Practices.

3.2.4 Disinfection System Redundancy

Another requirement for unfiltered water supply systems is disinfection facility redundancy. A system providing disinfection as the only treatment is required to assure that the water delivered to the distribution system is continuously disinfected. The SWTR requires either redundant disinfection equipment with auxiliary power and automatic start-up and alarm; or an automatic shutoff of delivery of water to the distribution system when the disinfectant residual level drops below 0.2 mg/L. In order to fulfill the requirement of providing redundant disinfection facilities, the following system is recommended:

- All components have backup units with capacities equal to or greater than the largest unit on-line.
- A minimum of two storage units of disinfectant which can be used alternately - e.g., two cylinders of chlorine gas, two tanks of hypochlorite solution
- Where the disinfectant is generated on-site, such as ozone, backup units with a capacity equal to or greater than that of the largest unit on-line.
- Automatic switchover equipment to change the feed from one storage unit to the other before the first empties or becomes inoperable

- Feed systems with backup units with capacities equal to or greater than the largest unit on-line.
- An alternate power supply such as a standby generator with the capability of running all the electrical equipment at the disinfection station. The generator should be on-site and functional with the capability of automatic start-up on power failure

Systems providing disinfection may have several different configurations for type and location of disinfectant application. The following guidelines are provided to assist Primacy Agencies and utilities in determining the need for redundancy. Possible disinfection configurations include:

- one disinfectant used for primary and secondary disinfection
 - one point of application
 - multiple points of application
- two different disinfectants used for primary and secondary disinfection

In many cases one disinfectant will be used to fulfill both the total inactivation and residual requirements. One or more application points may be used to accomplish this. When one application point is used to meet both the primary and secondary disinfection requirements, the system is required to include redundant disinfection facilities.

When multiple points of application are used, redundancy is recommended for the disinfection facilities at each point of application which is essential to meet the total inactivation requirements. In addition, to assure the maintenance of a residual entering and throughout the distribution system, either:

- the last point of application prior to the distribution system should have redundancy, or
- the point of application immediately prior to this point should have redundancy and sufficient capacity to assure a residual entering the distribution system.

Systems may also use two different disinfectants, one to fulfill the inactivation requirements and the second to maintain a residual. An

example of this would include a system using ozone as a primary disinfectant and chloramines as a secondary disinfectant. EPA recommends that:

- the disinfection facilities at each point of disinfectant application in the primary system essential in providing the overall inactivation requirements include redundancy, and
- the secondary disinfection facilities include redundancy, unless the disinfectant used for primary disinfection can provide a residual for the distribution system as well. If the primary disinfectant can be used for residual maintenance, the last point of primary disinfectant application should include redundancy and sufficient capacity to assure a residual entering the distribution system.

Appendix I contains more specific information to assist the Primacy Agency in establishing requirements for providing redundant disinfection facilities.

Providing automatic shutoff of water delivery requires approval by the Primacy Agency. The Primacy Agency must determine that this action will not result in an unreasonable risk to health or interfere with fire protection. This determination should include the evaluation of the system configuration to protect against negative pressures in the system, and providing for high demand periods including fire flow requirements. Automatic shutoff should be allowed only if systems have adequate distribution system storage to maintain positive pressure for continued water use.

3.3 SITE-SPECIFIC CONDITIONS

In addition to meeting source water quality criteria and disinfection criteria, nonfiltering systems using surface water supplies must meet the following criteria:

- Maintain a watershed control program
- Conduct a yearly on-site inspection
- Determine that no waterborne disease outbreaks have occurred
- Comply with the revised annual total coliform MCL
- Comply with TTHM regulations (currently applies to systems serving >10,000 people)

Guidelines for meeting these other criteria are presented in the following sections.

3.3.1 Watershed Control Program

A watershed control program is a surveillance and monitoring program which is conducted to protect the quality of a surface water source. An aggressive and detailed watershed control program is desirable to effectively limit or eliminate potential contamination by human viruses. A watershed program may impact parameters such as turbidity, certain organic compounds, viruses, total and fecal coliforms, and areas of wildlife habitation. However, the program is expected to have little or no impact on parameters such as naturally occurring inorganic chemicals. Limiting human activity in the watershed may reduce the likelihood of animals becoming infected with pathogens and thereby reduce the transmission of pathogens by wildlife. Preventing animal activity near the source water intake prior to disinfection may also reduce the likelihood of pathogen occurrence at the intake.

The effect of a watershed program is difficult to quantify since many variables that influence water quality are beyond the control or knowledge of the water supplier. As a result, the benefit of a watershed control program or specific control measures must in many cases be based on accumulated cause and effect data and on the general knowledge of the impact of control measures rather than on actual quantification. The effectiveness of a program to limit or eliminate potential contamination by human viruses will be determined based on: the comprehensiveness of the watershed review; the ability of the water system to effectively carry

out and monitor the management decisions regarding control of detrimental activities occurring in the watershed; and the potential for the water system to maximize land ownership and/or control of land use within the watershed. According to the SWTR, a watershed control program should include as a minimum:

- A description of the watershed including its hydrology and land ownership
- Identification, monitoring and control of watershed characteristics and activities in the watershed which may have an adverse effect on the source water quality
- A program to gain ownership or control of the land within the watershed through written agreements with land owners, for the purpose of controlling activities which will adversely affect the microbiological quality of the water
- An annual report which identifies special concerns in the watershed and how they are being handled, identifies activities in the watershed, projects adverse activities expected to occur in the future and how the utility expects to address them.

Appendix J contains a more detailed guide to a comprehensive watershed program.

In preparing a watershed control program, surface water systems should draw upon the State watershed assessments and nonpoint source (NPS) pollution management programs required by S319 of the Clean Water Act. Information on these programs is available from State water quality agencies or EPA's regional offices. Assessments identify NPS pollutants in water and assess the water quality. Utilities should use the assessments when evaluating pollutants in their watershed. Surface water quality assessments can also be obtained from the lists of waters prepared under S304(1) of the Clean Water Act, and State biennially prepared S305(b) reports.

State NPS management programs identify best management practices (BMPs) to be employed in reducing NPS pollution. These management programs can be incorporated in the watershed program to protect against degradation of the source water quality.

For systems using ground water sources under the influence of surface water, the control measures delineated in the Wellhead Protection (WHP) program encompass the requirements of the watershed control program, and can be used to fulfill the requirements of the watershed control program. Guidance on the content of State Wellhead Protection Programs and the delineation of wellhead protection areas is given in: "Guidance for Applicants for State Wellhead Protection Program Assistance Funds Under the Safe Drinking Water Act," June, 1987, and "Guidelines for Delineation of Wellhead Protection Areas," June, 1987, available from the EPA office of Ground-Water Protection (WH-550G).

As a minimum, the WHP program must:

- Specify the duties of State agencies, local governmental entities and public water supply systems with respect to the development and implementation of Programs;
- Determine the wellhead protection area (WHPA) for each wellhead as defined in subsection 1428(e) based on all reasonably available hydrogeologic information, ground-water flow, recharge and discharge and other information the State deems necessary to adequately determine the WHPA;
- Identify within each WHPA all potential anthropogenic sources of contaminants which may have any adverse effect on the health of persons;
- Describe a program that contains, as appropriate, technical assistance, financial assistance, implementation of control measures, education, training and demonstration projects to protect the water supply within WHPAs from such contaminants;
- Present contingency plans for locating and providing alternate drinking water supplies for each public water system in the event of well or wellfield contamination by such contaminants;
- Consider all potential sources of such contaminants within the expected wellhead area of a new water well which serves a public water supply system; and
- Provide for public participation.

3.3.2 On-site Inspection

The watershed control program and on-site inspection are inter-related preventive strategies. On-site inspection is actually a program which includes and surpasses the requirements of a watershed program.

While the watershed program is mainly concerned with the water source, on-site inspection includes some additional requirements for source water quality control and is also concerned with the disinfection facilities. As defined by the EPA, an on-site inspection includes review of the water source, disinfection facilities and operation and maintenance of a public water system for the purpose of evaluating the adequacy of such systems for producing safe drinking water.

The SWTR requires an annual on-site inspection to evaluate the watershed control program and disinfection facilities. The inspection must be performed by a party approved by the Primacy Agency. The inspection should be conducted by competent individuals such as sanitary and civil engineers, sanitarians, and technicians who have experience and knowledge in the operation, maintenance, and design of water systems, and who have a sound understanding of public health principles and waterborne diseases. Guidance for the contents of an inspection are included in the following paragraphs. Appendix K presents guidelines for a sanitary survey which includes and surpasses the requirements of an on-site inspection.

As the first step in determining which SWTR requirements, if any, a source is subject to, EPA recommends that utilities conduct a detailed, comprehensive sanitary survey. Appendix K presents a comprehensive list of water system features that the person conducting the survey should be aware of and review as appropriate. This initial investigation establishes the quality of the water source, its treatment and delivery to the consumer. EPA recommends that this comprehensive evaluation be repeated every three years for systems serving 4,100 people or less and every five years for systems serving more than 4,100 people. Also, under the Total Coliform Rule, ground water systems which take less than 5 coliform samples per month must conduct such sanitary surveys within every 5 or 10 years depending upon whether the source is protected and disinfected.

The annual on-site inspection to fulfill the SWTR requirements should include as a minimum:

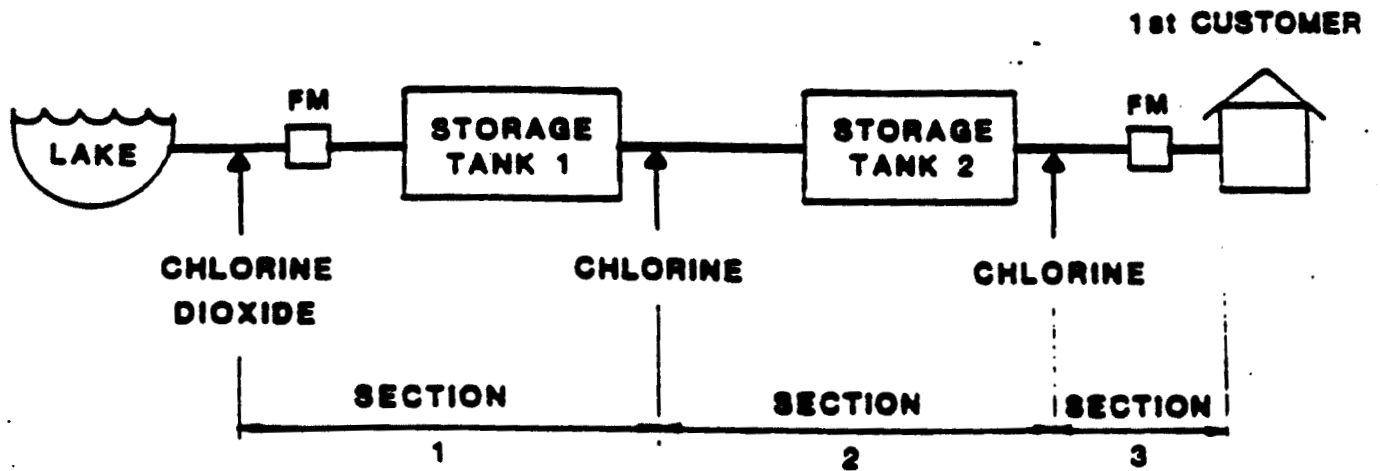

FIGURE 3-1. DETERMINATION OF INACTIVATION FOR MULTIPLE DISINFECTANT APPLICATION TO A SURFACE WATER SOURCE

1. Source Evaluation

- a. Review the effectiveness of the watershed control program (Appendix J).
- b. Review the physical condition and protection of the source intake.
- c. Review the maintenance program to insure that all disinfection equipment is appropriate and has received regular maintenance and repair to assure a high operating reliability.

2. Treatment Evaluation

- a. Review improvements and/or additions made to disinfection processes during the previous year to correct deficiencies detected in earlier surveys.
- b. Review the condition of disinfection equipment.
- c. Review operating procedures.
- d. Review data records to assure that all required tests are being conducted and recorded and disinfection is effectively practiced (CT calculations should be spot checked to ensure that they were done correctly).
- e. Identify any needed improvements in the equipment, system maintenance and operation, or data collection.

In addition to these requirements, a periodic sanitary survey is recommended for all systems, including those with filtered and unfiltered supplies. The sanitary survey should include the items listed in 1 and 2 above as well as:

3. Distribution System Evaluation

- a. Review the condition of storage facilities.
- b. Determine that the system has sufficient pressure throughout the year.
- c. Verify that system equipment has received regular maintenance.
- d. Review additions/improvements incorporated during the year to correct deficiencies detected in the initial inspection.

- e. Review cross connection prevention program, including annual testing of backflow prevention devices.
- f. Review routine flushing program for effectiveness.
- g. Evaluate the corrosion control program and its impact on distribution water quality.
- h. Review the adequacy of the program for periodic storage reservoir flushing.
- i. Review practices in repairing water main breaks to assure they include disinfection.

4. Management/Operation Evaluation

- a. Review the operations to assure that any difficulties experienced during the year have been adequately addressed.
- b. Review staffing to assure adequate numbers of properly trained and/or certified personnel are available.
- c. Verify that a regular maintenance schedule is followed.
- d. Audit systems records to verify that they are adequately maintained.
- e. Review bacteriological data from the distribution system for coliform occurrence, repeat samples and action response.

3.3.3 No Disease Outbreaks

Under the provisions of the SWTR, a surface water system which does not filter must not have been identified as a source of waterborne disease, or if it has been so identified, the system must have been modified sufficiently to prevent another such occurrence, as determined by the Primacy Agency. If a waterborne disease outbreak has occurred and the outbreak was or is attributed to a treatment deficiency, then the system must install filtration unless the system has upgraded its treatment system to remedy the deficiency which led to the outbreak and the Primacy Agency has determined that the system is satisfying this requirement. If the Primacy Agency has determined the disease outbreak was the result of a distribution system problem rather than a source water treatment deficiency, the system is not required to install filtration.

In order to determine whether the above requirement is being met, the responsible federal, state and local health agencies should be surveyed to obtain the current and historical information on waterborne disease outbreaks which may have occurred within a given system. Whether conducted by the Primacy Agency or submitted by the water purveyor, this information should include:

1. Source of the Information:
 - a. Name of agency
 - b. Name and phone number of person contacted
 - c. Date of inquiry
2. Outbreak Data
 - a. Known or suspected incidents of waterborne disease outbreaks
 - b. Date(s) of occurrence(s)
 - c. Type or identity of illness
 - d. Number of cases
3. Status of Disease Reporting:
 - a. Changes in regulations; e.g., giardiasis was not a reportable disease until 1985
4. If a Disease Outbreak has Occurred:
 - a. Was the reason for the outbreak identified; e.g., inadequate disinfection?
 - b. Did the outbreak occur while the system was in its current configuration?
 - c. Was remedial action taken?
 - d. Have there been any further outbreaks since the remedial action was taken?

If a review of the available information indicates that the system or network for disease reporting is inadequate within the Primacy Agency's area of responsibility, efforts should be made to encourage the appropriate agencies to upgrade the disease reporting capabilities within the area.

3.3.4 Monthly Coliform MCL

To avoid filtration, a system must comply with the MCL for total coliforms, established in the Total Coliform Rule, for at least 11 out of the previous 12 months the system served water to the public on an ongoing basis, unless the Primacy Agency determines that failure to meet this requirement was not caused by a deficiency in treatment of the source water. If the Primacy Agency makes such a determination, the system is not required to install filtration. The Total Coliform Rule requires systems using surface water or ground water under the influence of surface water which do not filter to collect a sample at or near the first customer each day that the turbidity level exceeds 1 NTU within 24 hours of learning of the result and to analyze the sample for the presence of total coliforms. (If the Primacy Agency determines that it is not possible for the system to have such a sample analyzed within 24 hours, this time limit may be extended on a case-by-case basis.) This sample may be used to fulfill the routine compliance monitoring requirements of the Total Coliform Rule. The results of the additional sample must be included in determining whether the system is in compliance with the monthly MCL for total coliforms.

3.3.5 Total Trihalomethane (TTHM) Regulations

For the system to continue to use disinfection as the only treatment, it must comply with the total trihalomethane (TTHM) MCL regulation. The current regulation established an MCL for total TTHM of 0.10 mg/L for systems serving a population greater than 10,000. Both the MCL and the system population covered may be reduced in the future, and this should be considered when planning disinfectant application.

One alternative to meet the CT requirements of the SWTR is to increase the disinfectant dose. For many systems, a higher chlorine dose will result in increased formation of TTHMs. Changes in disinfection practice should maintain TTHM levels of less than 0.10 mg/L. In lieu of increasing chlorine dose, use of an alternate disinfectant which produces fewer TTHMs could be considered. Alternate disinfectants include the use of ozone or chlorine dioxide as primary disinfectants with chlorine or chloramines as secondary (residual) disinfectants. It is important to note that EPA also will promulgate regulations for disinfectants and

disinfection by-products which may limit application of some of these disinfectants. EPA recommends that Primacy Agencies keep informed through communication with EPA on interim guidance on how to avoid conflict for systems to comply with both the SWTR and the forthcoming regulations on disinfectants and disinfection by-products. Any changes which appear to not meet the by-product regulations should not be implemented.

4. DESIGN AND OPERATING CRITERIA FOR FILTRATION AND DISINFECTION TECHNOLOGY

4.1 Introduction

To comply with the SWTR, public water systems must include filtration, or some other approved particulate removal technology, in their treatment process unless they are able to satisfy certain conditions. Those conditions include compliance with source water quality criteria and site-specific criteria. Guidance for determining whether these conditions are met is provided in Section 3 of this manual. Systems unable to satisfy these conditions must provide particulate removal and meet criteria pertaining to operation, design and performance. These criteria are specified in part in the definitions of technologies in the SWTR and more specifically as determined by the Primacy Agency.

This section provides guidance both for those water systems which currently do not have filtration equipment and must add it, and for systems which have existing filtration processes. Guidance on additional alternatives for small systems is presented in Appendix L.

This section includes guidance on the following topics:

- a. **Filtration Technology:** Descriptions, capabilities, design criteria and operating requirements for each technology, and a listing of major factors to be considered in their selection, including raw water quality considerations.
- b. **Disinfection:** Descriptions of the most applicable disinfection technologies used with filtration systems, and a presentation of the relative effectiveness of these disinfection technologies with respect to inactivation of bacteria, cysts and viruses.
- c. **Alternate Technologies:** Descriptions of some currently available alternate filtration technologies.
- d. **Other Alternatives:** Includes a description of some nontreatment alternatives including regionalization and use of an alternate source.

4.2 Selection of Appropriate Filtration Technology

Filtration is generally provided by passing water through a bed of sand, a layer of diatomaceous earth or a combination bed of coarse anthra-

cite coal overlaying finer sand. Filters are classified and named in a number of ways. For example, based on application rate, sand filters can be classified as either slow or rapid; yet these two types of filters differ in many more characteristics than just application rate. They differ in their removal process, bed material, method of cleaning, and operation. Based on the type of bed material, filters can be classified as sand, diatomaceous earth, dual-media (coal-sand) or even multi-media in which a third layer of high density sand is used.

4.2.1 General Descriptions

Current technologies specified by the SWTR are:

- a. **Conventional Treatment:** A series of processes including coagulation, flocculation, sedimentation and filtration.
- b. **Direct Filtration:** A series of processes including coagulation (and perhaps flocculation) and filtration, but excluding sedimentation.
- c. **Slow Sand Filtration:** A process which involves passage of raw water through a bed of sand at low velocity, generally less than 0.4 meters/hour (1.2 ft/hr), resulting in substantial particulate removal by physical and biological mechanisms.
- d. **Diatomaceous Earth Filtration:** A process that meets the following conditions:
 - A precoat cake of diatomaceous earth filter media is deposited on a support membrane (septum)
 - The water is filtered by passing it through the cake on the septum; additional filter media, known as body feed, is continuously added to the feed water in order to maintain the permeability of the filter cake.

e. **Alternate Technologies:** Any filtration process other than those listed above. Available alternate filtration technologies include, but are not limited to:

- Package Plants¹
- Cartridge Filters

4.2.2 Capabilities

Filtration processes provide various levels of turbidity and microbial contaminant removal. When properly designed and operated and when treating source waters of suitable quality, the above filtration processes are capable of achieving at least a 2-log (99 percent) removal of Giardia cysts and at least a 1-log (90 percent) removal of viruses without disinfection (Logsdon, 1987b; USEPA, 1988b; Roebeck, 1962). The exception is cartridge filters which may not provide effective virus removal. A summary of the removal capabilities of the various filtration processes is presented in Table 4-1.

As indicated in Table 4-1, conventional treatment without disinfection is capable of achieving up to a 3-log removal of Giardia cysts and up to a 3-log removal of viruses. Direct filtration can achieve up to a 3-log removal of Giardia cysts and up to a 2-log removal of viruses. Achieving the maximum removal efficiencies with these treatment processes requires the raw water to be properly coagulated and filtered. Factors which can adversely affect removal efficiencies include:

- Raw water turbidities less than 1 NTU
- Cold water conditions
- Non-optimal or no coagulation
- Improper filter operation including:

¹ Depending upon the type of treatment units in place, historical performance and/or pilot plant work, these plants could be categorized as one of the technologies in a-d above at the discretion of the State. Several studies have already indicated that some package plants effectively remove Giardia cysts. If such plants provided adequate disinfection so that the complete treatment train achieves at least a 3-log removal/inactivation of Giardia cysts and a 4-log removal/inactivation of viruses, use of this technology would satisfy the minimum treatment requirements.

- No filter to waste
- Intermittent operation
- Sudden rate changes
- Poor housekeeping
- Operating the filters after turbidity breakthrough

Studies of slow sand filtration have shown that this technology (without disinfection) is capable of providing greater than a 3-log removal of Giardia cysts and greater than a 3-log removal of viruses.

Factors which can adversely affect removal efficiencies include:

- Poor source water quality
- Cold water conditions
- Increases in filtration rates
- Decreases in bed depth
- Improper sand size
- Inadequate ripening

Diatomaceous earth (DE) filtration can achieve greater than a 3-log removal of Giardia cysts when sufficient precoat and body feed are used. However, turbidity and total coliform removals are strongly influenced by the grade of DE employed. Conversely, DE filtration is not very effective for removing viruses unless the surface properties of the diatomaceous earth have been altered by pretreatment of the body feed with alum or a suitable polymer. In general, DE filtration is assumed to achieve only a 1-log removal of viruses unless demonstrated otherwise. Factors which can affect the removal of Giardia cysts and viruses include:

- Precoat thickness
- Amount of body feed
- Grade of DE
- Improper conditioning of septum
- Improper pretreatment of the body feed

Package plants can be used to treat water supplies for communities as well as for recreational areas, parks, construction camps, ski resorts, military installations and other facilities where potable water is not available from a municipal supply. Operator requirements vary significantly with specific situations. Under unfavorable raw water conditions,

TABLE 4-1

REMOVAL CAPABILITIES OF FILTRATION PROCESSES⁽¹⁾

<u>Process</u>	<u>Log Removals</u>		
	<u>Giardia⁽²⁾ Cysts</u>	<u>Viruses</u>	<u>Total⁽²⁾ Coliform</u>
Conventional Treatment	2 - 3	1 - 3 ⁽³⁾	>4
Direct Filtration	2 - 3	1 - 2 ⁽³⁾	1 - 3
Slow Sand Filtration	2 - 3 ⁽⁵⁾	1 - 3 ⁽⁴⁾	1 - 2
Diatomaceous Earth Filtration	2 - 3 ⁽⁵⁾	1 - 2 ⁽²⁾	1 - 3

Note:

1. Without disinfection.
2. Logsdon, 1987b.
3. Roebeck *et al* 1962.
4. Poynter and Slade, 1977.
5. These technologies generally achieve greater than a 3-log removal.

package plants could demand full-time attention. Package plants are most widely used to treat surface supplies for removal of turbidity, color and coliform organisms prior to disinfection. They are currently available in capacities up to 6 mgd.

Colorado State University conducted a series of tests on one package plant over a 5-month period during the winter of 1985-86 (Horn and Hendricks, 1986). Existing installations in Colorado had proven effective for turbidity removal, and the tests at the university were designed to evaluate the system's effectiveness in removing coliform bacteria and Giardia cysts from low turbidity, low temperature source waters. The test results showed that the filtration system could remove greater than 99 percent of Giardia cysts for waters which had less than 1 NTU turbidity and less than 5 C temperatures, as long as proper chemical treatment was applied, and the filter rate was 10 gpm/ft² or less. In addition, an alternate water source having a turbidity ranging from 3.9 to 4.5 NTU was used in 12 test runs with coagulant doses ranging from 15 to 45 mg/L. The effluent turbidities from these runs were consistently less than 0.5 NTU.

Surveys of existing facilities indicate that while package plants may be capable of achieving effective treatment, many have not consistently met the interim MCL for turbidity, and in some cases, coliforms were detected in the filtered water (Morand et al., 1980; Morand and Young, 1983). The performance difficulties were primarily the result of the short detention time inherent in the design of the treatment units, the lack of skilled operators with sufficient time to devote to operating the treatment facilities, and the wide-ranging variability in quality of the raw water source. For instance, raw water turbidity was reported to often exceed 100 NTU at one site. Improvements in operational techniques and methods at this site resulted in a substantial improvement in effluent quality. After adjustments were made, the plant was capable of producing a filtered water with turbidities less than 1 NTU, even when influent turbidities increased from 17 to 100 NTU within a 2-hour period, as long as proper coagulation was provided.

One of the major conclusions of these surveys was that package water treatment plants manned by competent operators can consistently remove

turbidity and bacteria from surface waters of a fairly uniform quality. Package plants applied where raw water turbidities are variable require a high degree of operational skill and nearly constant attention by the operator. Regardless of the quality of the raw water source, all package plants require at least a minimum level of maintenance and operational skill and proper chemical treatment if they are to produce satisfactory water quality.

Cartridge filters using microporous filter elements (ceramic, paper or fiber) with pore sizes as small as 0.2 μm may be suitable for producing potable water from raw water supplies containing moderate levels of turbidity, algae and microbiological contaminants. The advantage to small systems of these cartridge filters is that, with the exception of disinfectant, no other chemicals are required. The process is one of strictly physical removal of small particles by straining as the water passes through a porous cartridge. Other than occasional cleaning or cartridge replacement, operational requirements are not complex and do not require skilled personnel. However, the SWTR does require each surface water system to be operated by a qualified operator, as determined by the Primacy Agency. Such a system may be suitable for some small systems where, generally, only maintenance personnel are available for operating water supply facilities. However, the use of cartridge filters should be limited to low turbidity source waters because of their susceptibility to rapid headloss buildup. For example, manufacturer's guidelines for achieving reasonable filter run lengths with certain polypropylene filter elements are that the raw water turbidity be 2 NTU or less (USEPA, 1988b).

Long (1983) analyzed the efficacy of a variety of cartridge filters using turbidity measurements, particle size analysis, and scanning electron microscope analysis. The filters were challenged with a suspension of microspheres averaging 5.7 μm in diameter which is smaller than a Giardia cyst. The microspheres were applied at a concentration of 40,000 to 65,000 spheres per ml. Ten of 17 cartridge filters removed over 99.9 percent of the microspheres.

In tests using live infectious cysts from a human source, cartridge filters were found to be highly efficient in removing Giardia cysts

(Hibler, 1986). Each test involved challenging a filter with 300,000 cysts at a concentration of 10,000 cysts/ml. The average removal for five tests was 99.86 percent, with removal efficiencies ranging from 99.5 percent to 99.99 percent.

The application of cartridge filters to small water systems using either cleanable ceramic or disposable polypropylene cartridges appears to be a feasible method for removing turbidity and most microbiological contaminants. However, data regarding the ability of cartridge filters to remove viruses are not available. Since disinfection by itself could achieve a 4-log inactivation of viruses, if the cartridge filter removes greater than or equal to 3 logs of Giardia, then the filter plus disinfection would achieve the overall minimum requirements, regardless of whether only negligible Giardia inactivation is achieved (e.g., less than 0.5 log). However, consideration should be given to the feasibility of providing multiple barriers of treatment for each target organism, i.e., some Giardia and virus removal by each barrier (i.e., some removal by filtration and some inactivation by disinfection) as protection in case one of the barriers fails. The efficiency and economics of the process must be closely evaluated for each situation. Pretreatment in the form of roughing filters (rapid sand or multi-media) or fine mesh screens may be needed to remove larger suspended solids which, if not removed, could cause the rapid buildup of headloss across the cartridges (USEPA, 1988a).

In general, conventional treatment, direct filtration, slow sand filtration and diatomaceous earth filtration can be designed and operated to achieve the maximum removal of the water quality parameters indicated in Table 4-1. However, for the purpose of selecting the appropriate filtration and disinfection technologies and for determining design criteria, these filtration processes should be assumed to achieve a 2-log removal of Giardia cysts and a 1-log removal of viruses. This conservative approach will assure that the treatment facility has adequate capability to respond to non-optimum performance due to changes in raw water quality, plant upsets, etc. The balance of the required removals and/or inactivation of Giardia cysts and viruses would be achieved through the application of appropriate disinfection.

The performance of alternate technologies such as cartridge filters, and possibly package plants, depending upon the unit under consideration cannot be stated with certainty at this time. Because of these performance uncertainties, pilot studies should be used to demonstrate their efficacy for a given water supply.

4.2.3 Selection

For any specific site and situation, a number of factors will determine which filtration technology is most appropriate. Among these are: raw water quality conditions, space and personnel availability, and economic constraints. A discussion of the impact of raw water quality on the technology selection is presented here. The impact of site-specific factors and economic constraints is presented in the USEPA document "Technologies and Costs for the Removal of Microbial Contaminants from Potable Water Supplies" (USEPA, 1988b).

Raw Water Quality Conditions

The number of treatment barriers provided should be commensurate with the degree of contamination in the source water. The four technologies specified in the SWTR vary in their ability to meet the performance criteria when a wide range of raw water quality is considered. While the numerical values of raw water quality that can be accommodated by each of the four technologies will vary from site to site, general guidance can be provided. General guidelines for selecting filtration processes, based on total coliform count, turbidity, and color are presented in Table 4-2. It is not recommended that filtration systems other than those listed in Table 4-2 be used when the general raw water quality conditions exceed the values listed, unless it has been demonstrated through pilot testing that the technology can meet the performance criteria under the raw water quality conditions expected to occur at the site.

The filtration processes listed in Table 4-1 are capable of achieving the required performance criteria when properly designed and operated if they are treating a source water of suitable quality (i.e., generally within the ranges indicated in Table 4-2). One of the causes

TABLE 4-2

GENERALIZED CAPABILITY OF FILTRATION SYSTEMS
TO ACCOMMODATE RAW WATER QUALITY CONDITIONS

<u>Treatment</u>	<u>General Restrictions</u>		
	<u>Total Coliforms (#/100 ml)</u>	<u>Turbidity (NTU)</u>	<u>Color (CU)</u>
Conventional with predisinfection	<20,000 ⁽³⁾	No restrictions ⁽³⁾	<75 ⁽²⁾
Conventional without predisinfection	<5,000 ⁽³⁾	No restrictions ⁽³⁾	<75 ⁽²⁾
Direct filtration with flocculation	<500 ⁽³⁾	<7-14 ⁽¹⁾	<40 ⁽⁴⁾
In-line filtration	<500 ⁽³⁾	<7-14 ⁽¹⁾	<10 ⁽³⁾
Slow sand filtration	<800 ⁽⁵⁾	<10 ⁽⁵⁾	<5 ⁽³⁾
Diatomaceous earth filtration	<50 ⁽³⁾	<5 ⁽³⁾	<5 ⁽³⁾

Notes:

1. Depends on algae population, alum or cationic polymer coagulation -- (Cleasby et al., 1984.)
2. USEPA, 1971.
3. Letterman, 1986.
4. Bishop et al., 1980.
5. Slezak and Sims, 1984.

of filtration failures is the use of inappropriate technology for a given raw water quality (Logsdon, 1987b). These criteria are general guidelines. Periodic occurrences of raw water coliform, turbidity or color levels in excess of the values presented in Table 4-2 should not preclude the selection or use of a particular filtration technology. For example, the following alternatives are available for responding to occasional raw water turbidity spikes:

- a. Direct Filtration
 - Continuous monitoring and coagulant dose adjustment
 - More frequent backwash of filters
 - Use of presedimentation
- b. Slow Sand Filtration
 - Use of a roughing filter
 - Use of an infiltration gallery
- c. Diatomaceous Earth Filtration
 - Use of a roughing filter
 - Use of excess body feed

For the above alternatives, EPA recommends that pilot testing be conducted to demonstrate the efficacy of the treatment alternative.

The characteristics of each filtration technology are a major factor in the selection process. Significant characteristics include performance capabilities (contaminant removal efficiencies), design and construction requirements, and operation and maintenance requirements. Details regarding each of the four filtration technologies are presented in the following section.

4.3 Available Filtration Technologies

4.3.1 Introduction

As indicated in the preamble to the SWTR, the historical responsibility of the States to establish design and operating criteria for public drinking water plants will continue. The purpose of the following sections is to provide guidance on how the design and operating criteria may need to be changed in order to assure that the performance criteria in the SWTR are met.

The design criteria for the various filtration technologies found in the 1987 edition of Recommended Standards for Water Works (Great Lakes, 1987) are the minimum design criteria that a majority of states are currently following.² These standards are referred to as Ten States Standards in the remainder of this manual. The design criteria contained in the Ten States Standards have not been duplicated here. Rather, the reader is referred to the Ten States Standards directly. EPA recommends the following additions and/or changes to the Ten State Standards in order to assure compliance with the performance criteria of the SWTR.

4.3.2 General

The following recommendations apply to all filtration plants:

- a. All filtration plants should provide continuous turbidity monitoring of the effluent turbidity from each individual filter.^{3,4} If continuous monitoring is impractical, routine monitoring of individual filters is recommended as a minimum.
- b. All filtration systems should be concerned with the peak turbidity levels in the filtered water after backwashing and

² Based upon the results of a survey conducted for the American Water Works Association Research Foundation (AWWARF), some 38 states use the Ten States Standards entirely or in modified form (AWWARF, 1986).

³ Although this is not a requirement of the SWTR, it is recommended because of the possibility that not all filters in a treatment plant will produce the same effluent turbidity. This may be due to a variety of conditions that include bed upsets, failure of media support or underdrain systems, etc. Although the combined effluent from all the filters may meet the turbidity requirements of the SWTR, the turbidity level from an individual filter may substantially exceed the limits. This may result in the passage of Giardia cysts or other pathogens.

⁴ Validation should be performed at least twice a week based on the procedure outlined in Part 214A in the 16th Edition of Standard Methods. It should be noted that improper installation of continuous monitors may allow for air bubbles to enter the monitor resulting in false turbidity spikes. To avoid air bubbles reaching the turbidimeter the sample tap should be installed below the center line of the pipe and an air release valve may be included on the sample line.

make every attempt to operate the filters to minimize the magnitude and duration of these turbidity spikes.⁵

Individual filters should be monitored as discussed in Section 4.3.2.a and when excessive turbidity spikes are found, corrective actions taken. During these turbidity peaks, Giardia cysts and other pathogens may be passed into the finished water. There is evidence that a 0.2 to 0.3 NTU increase in the turbidity during the first period of the filter run can be associated with rises in Giardia cyst concentrations by factors of twenty to forty (Logsdon, 1985). Special studies should be conducted to determine the extent of the turbidity spike problems.

There are basically four approaches available for correcting problems with turbidity spikes after backwashing. These are as follows (Bucklin, et al 1988):

- Proper chemical conditioning of the influent water to the filter can minimize the magnitude and duration of these turbidity spikes. This could include proper control of the primary coagulant chemicals such as alum or iron compounds. In some cases filter aids using polymers may be needed to control the turbidity spikes.
- Gradually increasing the filtration rate in increments when placing the filter in operation. Starting the filter at a low flow rate and then increasing the flow in small increments over 10 to 15 minutes has been shown to reduce the turbidity spikes in some cases (Logsdon, 1987).
- Addition of coagulants to the backwash water has also been shown to reduce the extent of turbidity spikes after backwash. Typically the same primary coagulant used in the plant is added to the backwash water. Polymers alone or in combination with the primary coagulant may also be used.
- Filter-to-waste may be practiced where a portion of the filtered water immediately after starting the filter is wasted. This is only possible where the filter system has

⁵ For most high rate granular bed filters, there is a period of conditioning, or break-in immediately following backwashing, during which turbidity and particle removal is at a minimum, referred to as the break-in period. The turbidity peaks are thought to be caused by remnants of backwash water within the pores of and above the media passing through the filter, and/or floc breakup during the filter ripening period before it can adequately remove influent turbidity.

provided the necessary valves and piping to allow this procedure. There is some concern whether or not this practice is beneficial. The extra valve operations needed for filter-to-waste can disrupt the filter flow rate to the extent that they create their own turbidity spikes. Some knowledge of the time actually needed for filter-to-waste is also needed before it can be determined that this is an effective procedure for controlling turbidity spikes. If the length of time the filter-to-waste is practiced is less than that before the turbidity spike passes, the disruption caused by the valve operation may actually increase the turbidity spike.

Different plants and the individual filters within the plant may have different turbidity spike characteristics. The four approaches presented above, therefore, must be evaluated on a case-by-case basis. Special studies will be required to identify those filters with the turbidity spike problems and assist in selecting which of the four approaches is best for correcting the problem. It has been generally found that turbidity spikes can be minimized through one or a combination of the first three approaches.

In order to establish filter-to-waste operating guidelines, the following procedure is suggested:

- Review the effluent turbidity data for each filter and determine which filter historically has the highest effluent turbidity.
- Following backwashing of the filter with the poorest performance, place that filter into service and collect grab samples every 5 to 10 minutes for a period of at least 60 minutes.⁶
- Analyze the grab samples for turbidity and determine how long the filter must be in operation before the effluent turbidity drops
 - to less than or equal to 0.5 NTU
 - or 1 NTU in cases where a filtered water turbidity of less than or equal to 1 NTU is allowed.

⁶ Continuous turbidity monitoring can be used in place of grab sampling.

Limited information exists on the typical magnitude and duration of peak turbidity levels after backwashing and what levels are considered acceptable to assure that these turbidity spikes are not associated with passage of Giardia cysts. Information from plant scale tests, showing the typical magnitude and duration of these turbidity spikes is available from two plants (Bucklin et al., 1988). Studies conducted at these plants over a year showed that these peaks occurred within the first few minutes after the filter was placed back in operation, their effects lasted for several hours, and varied in magnitude from 0.08 to 0.35 NTU on average.

For existing plants without provisions for filter-to-waste, the decision to add the necessary piping to provide this capability should be made only after carefully evaluating the other three approaches. If the results of special studies show that the other three options are not effective in minimizing the turbidity spikes then the expense of adding the filter-to-waste capabilities may be justified.

For new plants the capability of filter-to-waste may be required by the Primacy Agency or should be considered. By having this capability, additional flexibility will be available for turbidity spike control. This flexibility may also be useful for other filter maintenance functions such as after media replacement or when heavy chlorination of the filter is needed after maintenance.

4.3.3 Conventional Treatment

Conventional treatment is the most widely used technology for removing turbidity and microbial contaminants from surface water supplies. Conventional treatment includes the pretreatment steps of chemical coagulation, rapid mixing, flocculation and sedimentation followed by filtration. These conventional treatment plants typically use aluminum and iron compounds in the coagulation processes. Polymers may also be used to enhance the coagulation and filtration processes. A flow sheet for a conventional treatment plant is presented on Figure 4-1.

Lime softening is a treatment process used to remove hardness and turbidity from surface waters. Treatment is typically accomplished with conventional process units. The lime softening process removes the

calcium and magnesium from the water by precipitating them as calcium carbonate and magnesium hydroxide. Turbidity levels in the water are also reduced by this process. Lime and possibly soda ash is added to the raw water to raise its pH to a point at which these precipitates are formed and then removed from the water during sedimentation and filtration. Lime softening may be used for the removal of carbonate hardness in the pH range of 9 to 10 through a single stage process. Two-stage lime/soda ash softening at a pH of 10 to 12 can be used for the removal of non-carbonate hardness and magnesium. Two-stage softening includes recarbonation to neutralize the caustic alkalinity, reducing the pH to the range of 8.5 to 9.5. A flow sheet for typical one- and two-stage softening plants is presented on Figure 4-2.

Each of these three conventional treatment processes uses filtration following sedimentation. Three different types of filters are used. Sand filters, normally found in older plants, use a single media of sand to form a filter bed, and are generally designed with a filtration rate of 2 gpm/ft². Newer plants normally use dual-media or mixed media filters. Dual media filters use a combination of anthracite coal along with a sand to form the filter bed. Mixed media filters use coal, sand, and a third material to form the filter bed. Dual and mixed media filters can be designed to operate at higher filtration rates than sand filters, i.e., 4 to 6 gpm/ft².

Design Criteria

The minimum design criteria in the Ten State Standards for conventional treatment are considered sufficient for the purposes of complying with the SWTR with the following addition:

- The criteria for sedimentation should be expanded to include other methods of solids removal including dissolved air flotation. Plate separation and upflow-solids contact clarifiers included in the 1987 Ten State Standards should also be considered.

Operating Requirements

In addition to the operating requirements in the Ten State Standards, a coagulant should be used at all times the treatment plant is

in operation.⁷ Conventional and direct filtration plants must be monitored carefully because failure to maintain optimum coagulation can result in poor filter performance and breakthrough of cysts and viruses.⁸ Although the detention time provided by the settling basins results in some margin of safety, the loss of coagulation control at the chemical feed or rapid mix points may not be noticed until the poorly coagulated water reaches the filters, after the process has failed. Failure to effectively monitor and control filter operation can result in undetected poor filter performance (Logsdon, 1987a; Logsdon, 1987b).

Effective operation of a conventional treatment plant requires careful monitoring and control of:

- Chemical Feed
- Rapid Mix
- Flocculation
- Sedimentation
- Filtration

For the purposes of the SWTR, the requirements for effective operation of a conventional water treatment plant can be summarized as follows:

- a. The application of a coagulant and the maintenance of effective coagulation and flocculation at all times when a treatment plant is in operation.⁹ Proper process control

⁷ Dependable removal of Giardia cysts can not be guaranteed if a water is filtered without being properly coagulated (Logsdon, 1987b; Al-Ani et al., 1985). This is true even if the raw water turbidity is less than 1 NTU.

⁸ As indicated in the preamble to the proposed SWTR, 33 percent of the reported cases of giardiasis in waterborne disease outbreaks were attributed to improperly operated filtration plants.

⁹ Some conventional water treatment plants which treat low turbidity source waters (<1 NTU) reportedly discontinue the application of coagulant(s) during periods of low turbidity since the raw water already meets the turbidity MCL. However, studies have shown that cyst removal for low turbidity waters is the most difficult to achieve and requires optimum pretreatment including coagulation to achieve effective removals

procedures should be used at the plant to assure that chemical feeds are adjusted and maintained in response to variations in raw water temperature and turbidity.

b. Maintenance of effective filtration will require proper operation procedures to meet the turbidity requirements of the SWTR. Proper operation should include:

- Proper chemical conditioning of the water ahead of the filter to assure adequate turbidity removal through the filter.
- Control of the flow rates and elimination of rapid changes in flow rate applied to the filter.
- Backwashing of filters before the filtered water quality is degraded to the point that the plant fails to meet the turbidity requirements of the SWTR. The criteria on which to base initiation of backwash will have to be determined for each plant. Experience with operation cycles including run times and headloss data may serve as the basis for this site specific criteria.
- After backwash bringing the clean filters back on line so that excessive turbidity spikes in the filtered water are not created. Section 4.3.2.B of this manual discusses these turbidity spikes and approaches available to minimize them.

c. Filters removed from service generally should be backwashed upon start-up. However, in some cases, it may be impractical to backwash filters each time they are removed from service. Accordingly, the Primacy Agency may choose to allow start-up without backwashing under certain conditions on a site-by-site basis. In making this decision, the following should be considered:

- the length of time the filter was off-line
- performance of the filter while being put on-line

The filter should be brought back on-line in such a way that no turbidity spikes that could be associated with passage of

(Al-Ani et al., 1985).

Giardia cysts and other pathogens occur. If problems with turbidity spikes are found when starting up dirty filters, special studies should be used to evaluate if any of the approaches discussed in Section 4.3.2.B of this manual are effective in minimizing the turbidity spikes.

4.3.4 Direct Filtration

A direct filtration plant can include several different pretreatment unit processes depending upon the application. In its simplest form, the process includes only in-line filters preceded by chemical coagulant application and mixing. The mixing step, particularly in pressure filters, can be satisfied by influent pipeline turbulence. In larger plants with gravity filters, an open rapid-mix basin with mechanical mixers typically is used. Figure 4-3 illustrates the unit processes of a typical direct filtration plant.

Another variation of the direct filtration process consists of the addition of a coagulant to the raw water followed by rapid mixing and flocculation, as illustrated on Figure 4-4. The chemically conditioned and flocculated water is then applied directly to a dual- or multi-media filter (USEPA, 1988b).

Design Criteria

The 1987 edition of the Ten State Standards recommends pilot studies to determine most design criteria. For the purposes of implementation of the SWTR this requirement is considered sufficient with the following exception:

- a. A coagulant must be used at all times when the treatment plant is in operation.¹⁰

¹⁰ Optimum coagulation is critical for effective turbidity and microbiological removals with direct filtration (Al-Ani et al., 1985).

Operating Requirements

Operating considerations for direct filtration plants are essentially identical to those for conventional treatment plants. The major difference is that a direct filtration plant will not have a clarifier, and may or may not have a flocculation or contact basin. In addition, EPA recommends that all direct filtration plants, both new and existing, be required to make provisions to minimize the break-in time of a filter being put on-line.¹¹

As with conventional treatment, the initiation of backwashing a filter should first be based on filter effluent turbidity values, then by headloss and run time. Effluent turbidity monitoring equipment should be set to initiate filter backwash at an effluent value of 0.5 NTU or less, in order to meet filtered water quality requirements. Also, any filters removed from service should be backwashed upon start-up. In some cases, it may not be practical to backwash filters every time they are removed from service. This decision should be made by the Primacy Agency on a case-by-case basis, based on the same considerations as for conventional systems.

4.3.5 Slow Sand Filtration

Slow sand filters differ from single-media rapid-rate filters in a number of important characteristics. In addition to the difference of flow rate, slow sand filters:

- a. Function using biological mechanisms as well as physical-chemical mechanisms
- b. Use smaller sand particles
- c. Are not backwashed, but rather are cleaned by removing the surface media
- d. Have much longer run times between cleaning

¹¹ As with conventional treatment, direct filtration produces a relatively poor quality filtered water at the beginning of filter runs and therefore a filter-to-waste period is recommended. In some cases, the addition of a filter aid or bringing filters on-line slowly will be appropriate (Cleasby et al., 1984).

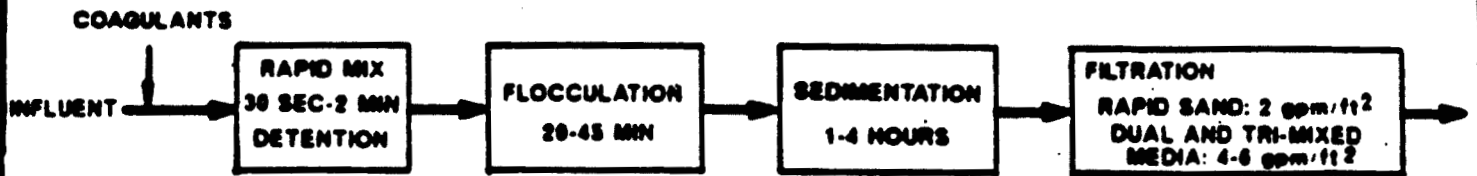

**FIGURE 4-1-FLOW SHEET OF A TYPICAL CONVENTIONAL
WATER TREATMENT PLANT**

SINGLE STAGE SOFTENING [1]

LIME

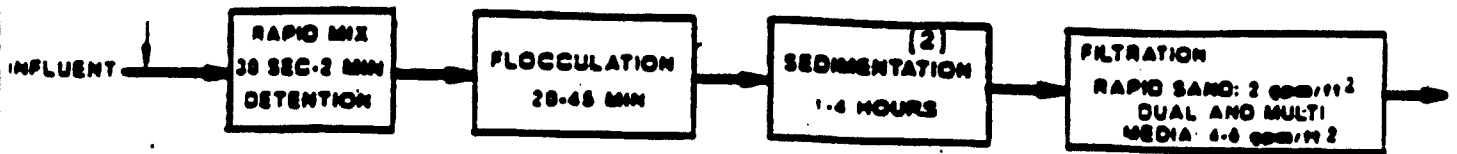

[1] PH RANGE 9-10

[2] OR ALTERNATE SOLIDS REMOVAL PROCESS

TWO STAGE SOFTENING [1]

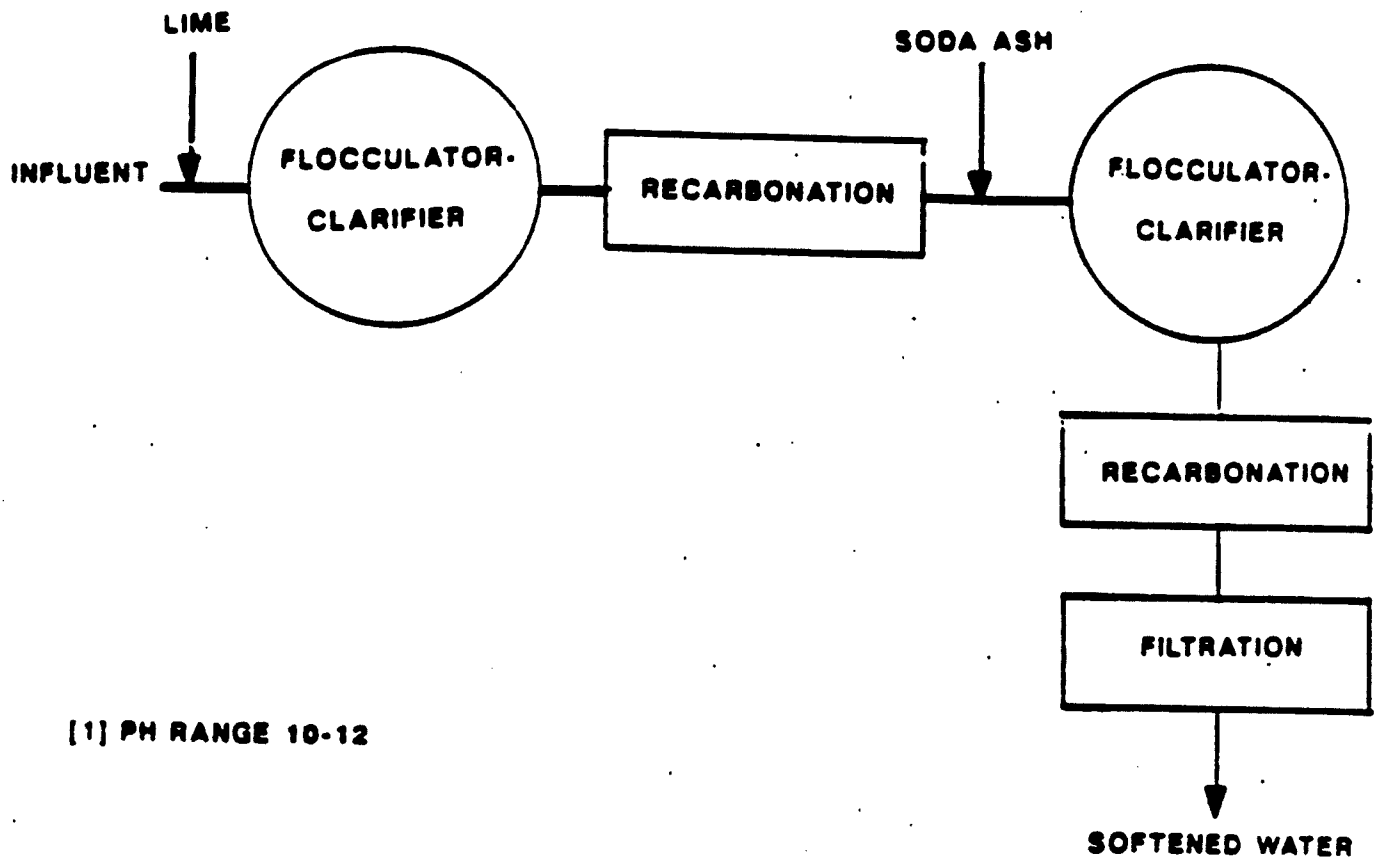

[1] PH RANGE 10-12

FIGURE 4-2-FLOW SHEET OF TYPICAL SOFTENING TREATMENT PLANTS

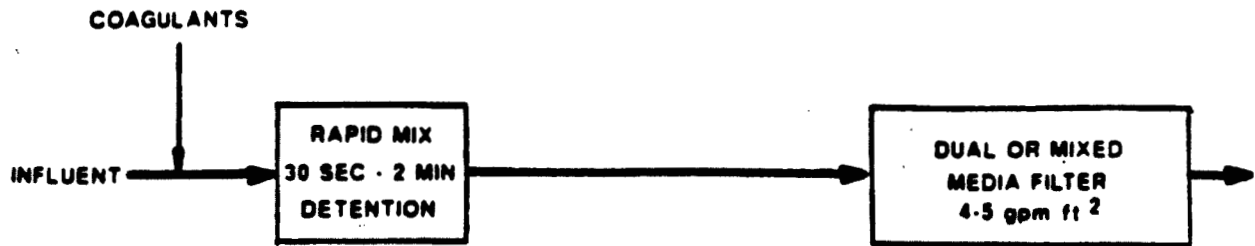

**FIGURE 4-3 FLOW SHEET FOR A TYPICAL
DIRECT FILTRATION PLANT**

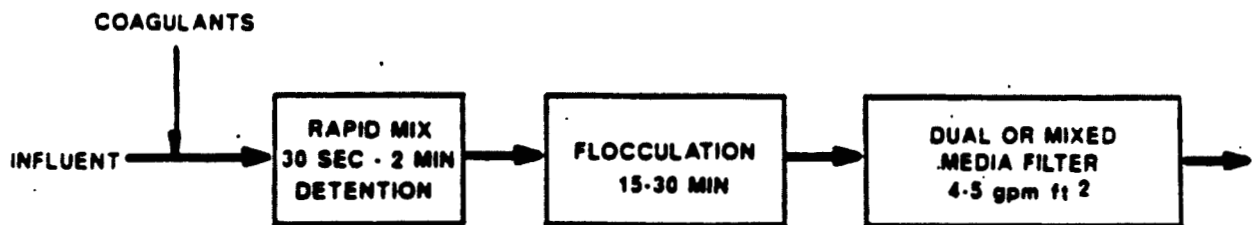

**FIGURE 4-4-FLOW SHEET FOR A TYPICAL DIRECT
FILTRATION PLANT WITH FLOCCULATION**

- e. Require a ripening period at the beginning of each run

Although rapid rate filtration is the water treatment technology used most extensively in the United States, its use has often proved inappropriate for small communities since rapid-rate filtration is a technology that requires skilled operation by trained operators. Slow sand filtration requires very little control by an operator. Consequently, use of this technology may be more appropriate for small systems where source water quality is within the guidelines recommended in Section 4.2.3.

As indicated in this section, slow sand filtration also may be applicable to other source water quality conditions with the addition of pretreatment such as a roughing filter or presedimentation.

Design Criteria

The minimum design criteria presented in the Ten State Standards for slow sand filters are considered sufficient for the purposes of implementation of the SWTR with the following exceptions:

- a. Raw water quality limitations should be changed to reflect the values given in Table 4-2.¹²
- b. The effective sand size should be between 0.15mm and 0.35mm rather than the current 0.30 mm to 0.45 mm.¹³

Additional guidance on the design of slow sand filtration is available in the design manual entitled Slow Sand Filtration for Community Water Supplies Technical Paper 24, 1987 published by the International

¹² Without pretreatment, limitations exist in the quality of water that is suitable for slow sand filtration (Logsdon, 1987b; Cleasby et al., 1984; Bellamy et al., 1985; Fox et al., 1983).

¹³ Significant decreases in total coliform removals were shown at effective sand sizes less than 0.35 mm (Bellamy et al., 1985). As defined in the AWWA Standard for Filtering Material, effective size is the size opening that will pass 10 percent by weight of a sample of filter material.

Reference Centre for Community Water Supply and Sanitation (IRC),
P.O. Box 5500, 2280 HM Rijswijk, the Netherlands.

Operating Requirements

Maintenance of a slow sand filter involves two periodic tasks:

- a. Removal of the top 2 to 3 cm (0.8 to 1.2 inches) of the surface of the sand bed when the headloss exceeds 1 to 1.5 m.¹⁴
- b. Replacement of the sand when repeated scrapings have reduced the depth of the sand to approximately one-half of its design depth (Bellamy et al., 1985).

Following scraping, slow sand filters produce poorer quality filtrate at the beginning of a run, and a filter-to-waste or ripening period of one to two days is recommended before use to supply the system. The ripening period is an interval of time immediately after a scraped filter is put back on-line, when the turbidity or particle count results are significantly higher than the corresponding values for the operating filter. During this time, the microorganisms multiply and attain equilibrium in the "schmutzdecke." Filter effluent monitoring results should be used to determine the end of the ripening period. For example, a turbidimeter could be set at 1.0 NTU or less to initiate start of the filter run.

When repeated scrapings of the sand have reduced the depth of the sand bed to approximately one-half of its design depth, the sand should be replaced. Filter bed depths of less than 0.3 to 0.5 m (12 to 20 inches) have been shown to result in poor filter performance (Bellamy et al., 1985). The replacement procedure should include removal of the remaining sand down to the gravel support, the addition of new sand to one half of the design depth and placement of the sand previously removed on top of the new sand.¹⁵

¹⁴ Removal of this top layer of the "Schmutzdecke" should restore the filter to its operational capacity and initial headloss.

¹⁵ This procedure results in clean sand being placed in the bottom half of the filter bed and biologically active sand in the top half reducing the amount of time required for the curing period. It also provides

The amount of time for the biological population to mature in a new sand filter (also called curing) and to provide stable and full treatment varies. The World Health Organization (1980) reported that curing requires a few weeks to a few months. Fox et al., (1983) found that "about 30 days" were required to bring particle and bacterial effluents down to a stable level. All researchers agree that a curing time for a new filter is required before the filter operates at its fullest potential (Bellamy et al., 1985).

4.3.6 Diatomaceous Earth Filtration

Diatomaceous earth (DE) filtration, also known as precoat or diatomite filtration, is appropriate for direct treatment of surface waters for removal of relatively low levels of turbidity and microorganisms.

Diatomite filters consist of a layer of DE about 3 mm (1/8 inch) thick supported on a septum or filter element. The thin precoat layer of DE must be supplemented by a continuous body feed of diatomite, which is used to maintain the porosity of the filter cake. If no body feed is added, the particles filtered out will build up on the surface of the filter cake and cause rapid increases in headloss. The problems inherent in maintaining the proper film of DE on the septum have restricted the use of diatomite filters for municipal purposes, except under certain favorable raw water quality conditions, i.e., low turbidity and good bacteriological quality. Specific upper limits of raw water quality parameters are not well-defined because diatomaceous earth filtration performance depends on the nature, as well as the concentration, of the raw water particles and the grades of diatomite employed. Logsdon (1987b) reported that filtered water turbidities above 1 NTU and short filter runs were observed for several diatomaceous earth plants having maximum raw water turbidities above 20 NTU.

for a complete exchange of sand over time, alleviating potential problems of excessive silt accumulation and clogging of the filter bed (Bellamy et al., 1985).

Design Criteria

The minimum design criteria presented in the Ten State Standards for diatomaceous earth filtration are considered sufficient for the purposes of compliance with the SWTR with the following exceptions:

- a. The recommended quantity of precoat is 1 kg/m² (0.2 pounds per square foot) of filter area, and the minimum thickness of the precoat filter cake is 3mm to 5mm (1/8 to 1/5-inch).¹⁶
- b. Treatment plants should be encouraged to provide a coagulant coating (alum or suitable polymer) of the body feed.¹⁷

Operating Requirements

Operating requirements specific to DE filters include:

- Preparation of body feed and precoat
- Verification that dosages are proper
- Periodic backwashing and disposal of spent filter cake
- Periodic inspection of the septum(s) for cleanliness or damage
- Verification that the filter is producing a filtered water that meets the performance criteria

4.3.7 Alternate Technologies

The SWTR allows the use of filtration technologies other than those specified above provided that the system demonstrates to the Primacy Agency using pilot studies or other means that the filtration technology when combined with disinfection achieves at least 3-log Giardia cyst and 4-log virus removal/inactivation. Such technologies must also meet the turbidity performance criteria for slow sand filtration. Guidance for

¹⁶ Studies have shown that a precoat thickness of 1 kg/m² (0.2 lbs/ft²) was most effective in Giardia cyst removal and that the precoat thickness was more important than the grade size in cyst removal (DeWalle et al., 1984; Logsdon et al., 1981; Bellamy et al., 1984).

¹⁷ Although enhancement of the DE is not required for Giardia cyst removal, coagulant coating of the body feed has been found to significantly improve removals of viruses, bacteria and turbidity. (Brown et al., 1974; Bellamy et al., 1984).

conducting pilot studies to demonstrate this effectiveness is provided in Appendix M of this manual.

Reverse osmosis is a membrane filtration method which is used for desalination and/or the removal of organic contaminants. The treatment process is effective for the removal of Giardia cysts and viruses and no demonstration is necessary.

Alternate filtration technologies which are currently available include, but are not limited to:

- Package Plants
- Cartridge Filters

Package plants in principle are not a separate technology from the preceding technologies. However, in many cases they are different enough in design criteria, and operation and maintenance requirements that they should be considered as an alternate technology. The package plant is designed as a factory-assembled, skid-mounted unit generally incorporating a single, or at most, a few process units. A complete treatment process typically consists of chemical coagulation, flocculation, settling and filtration. Package plants generally can be applied to flows ranging from about 25,000 gpd to approximately 6 mgd (USEPA, 1988b). In cases where the Primacy Agency believes that the design criteria of the package plant corresponds to the design criteria of the processes established earlier in this section (i.e., that the package plant qualifies as conventional or direct filtration), the requirement of pilot testing may be waived.

The application of cartridge filters using either cleanable ceramic or disposable polypropylene cartridges to small water systems may be a feasible method for removing turbidity and some microbiological contaminants, such as Giardia cysts although no data are available regarding their ability to remove viruses. Pilot studies are required to demonstrate the efficacy of this technology for a given supply. However, if the technology was demonstrated to be effective through pilot plant studies at one site, then the technology could be considered to be effective at another site which had similar source water quality conditions. Therefore, pilot plant testing at the new site might not be necessary.

It is important to note that the demonstration of achieving the 3-log Giardia cyst and 4-log virus removal/inactivation requirements includes disinfection. Thus, if a cartridge filter is demonstrated to achieve a 3-log removal of Giardia cysts and it is determined by CTs that the disinfection achieves at least a 4-log virus inactivation, the effectiveness of the technology would be demonstrated. The technology must also maintain turbidities less than 1 NTU in 95 percent of the monthly samples. Meeting this turbidity requirement assures a high probability that turbidity will not interfere with disinfection and that the inactivation efficiencies predicted by the CTs are reliable.

Design Criteria

After any necessary pilot studies are conducted and a successful demonstration of performance has been made, design criteria should be established and approved by the Primacy Agency. Eventually, a sufficiently large data base will become available, making it easier to apply the alternate technologies to other water supplies of similar quality.

Operating Requirements

After any necessary pilot studies are conducted and a successful demonstration of performance has been made, operating requirements should be established and approved by the Primacy Agency.

4.3.8 Nontreatment Alternatives

Under certain circumstances, some systems may have other alternatives available. These alternatives include regionalization and the use of alternate sources.

For small water systems which must provide filtration, a feasible option may be to join with other small or large systems to form a regional water supply system. In addition, alternative water sources located within a reasonable distance of a community which would allow the system to meet the requirements of the SWTR and other applicable drinking water regulations, may be developed to provide a satisfactory solution to a community water quality problem. The availability of alternative ground

water sources will depend upon the size and location of the system and the costs involved.

4.4 Disinfection

4.4.1 General

The SWTR requires that disinfection be included as part of the treatment of surface water for potable use. As noted earlier, EPA recommends that the number of treatment barriers be commensurate with the degree of contamination in the source water in accordance with Table 4-2. For example, as indicated in Table 4-2, when the total coliforms in the source water are greater than 5,000/100 ml, conventional treatment with pre-disinfection is recommended. However, the selection of appropriate disinfection requires consideration of other factors in addition to those included in Table 4-2. These considerations include:

- a. Source water quality and the overall removal/inactivation of Giardia cysts and viruses desired.
- b. Likelihood of TTHM formation.
- c. Potential need for an oxidant for purposes other than disinfection including control of taste; odor, iron, manganese, color, etc.

4.4.2 Recommended Removal/Inactivation

The SWTR requires a minimum 3-log removal/inactivation of Giardia cysts and a minimum 4-log removal/inactivation of viruses:

- a. Well-operated conventional treatment plants which have been optimized for turbidity removal can be expected to achieve at least a 2.5-log removal of Giardia cysts.
- b. Well-operated diatomaceous earth, slow sand filtration and direct filtration plants can be expected to achieve at least 2-log removal of Giardia cysts.

EPA recommends that:

- a. Conventional filtration systems provide sufficient disinfection to achieve a minimum of 0.5-log Giardia cyst and 2-log virus inactivation.

- b. Slow sand filtration systems provide sufficient disinfection to achieve a minimum of 2-log Giardia cyst and 2-log virus inactivation.
- c. Systems using diatomaceous earth and direct filtration, or other filtration methods, should provide sufficient disinfection to achieve a minimum of 1-log Giardia cyst and 3-log virus inactivation.

Further guidance on the disinfection level to be provided is contained in Section 5. CT values for achieving these inactivations are presented in Appendix E. As indicated in this Appendix:

- a. A comparison of Tables E-1 through E-6 with Table E-7 indicates that systems which achieve a 0.5-log inactivation of Giardia cysts, using free chlorine, will achieve greater than a 4-log inactivation of viruses.
- b. Ozone and chlorine dioxide are generally more effective at inactivating viruses than Giardia cysts. However, as indicated in Tables E-8 through E-11, there are some conditions under which the disinfection needed to provide the recommended virus inactivation is higher than that needed for the recommended Giardia cyst inactivation. Therefore, a system using ozone or chlorine dioxide for disinfection must check the CT values needed to provide the recommended inactivation of both Giardia cysts and viruses and provide the higher of the two disinfection levels. Systems may demonstrate their efficiency for overall removal/inactivation using the protocol in Appendices G and M.
- c. As indicated in Tables E-12 and E-13, chloramines are much less effective for inactivating Giardia cysts and viruses than the other disinfectants. Also, chloramines may be applied to the system in several ways, either with chlorine added prior to ammonia, ammonia added prior to chlorine or preformed. For systems applying chlorine ahead of ammonia, the required level of disinfection may be determined as follows:
 - determine the CT needed to provide the required inactivation of Giardia and viruses and provide the higher of the two levels or

- follow the protocol in Appendix G to demonstrate effective inactivation to allow lower levels of disinfection.

For systems applying ammonia ahead of chlorine or preformed chloramines, the EPA recommends that the system demonstrate effective virus inactivation according to the protocol in Appendix G, since the CT values for virus inactivation in Table E-13 only apply to the addition of chlorine prior to ammonia.

Although the SWTR requires a minimum of a 3-log removal/inactivation of Giardia cysts and a minimum of a 4-log removal/inactivation of viruses, it may be appropriate for the Primacy Agency to require greater removals/-inactivations depending upon the degree of contamination within the source water.

Rose (1988) conducted a survey of water sources to characterize the level of Giardia cyst occurrence for "polluted" and "pristine" waters. Polluted waters are defined as waters in the vicinity of sewage and agricultural wastes, while pristine waters are those originating from protected watersheds with no significant sources of microbiological contamination from human activities. EPA believes that treatment should be provided to assure less than one case of microbiologically-caused illness per year per 10,000 people. In order to provide this level of protection, 3, 4 or 5-log Giardia cyst removal/inactivation should be provided for the following source water qualities:

Giardia Cyst Removal/Inactivation Required Based^{18, 19}
on Source Water Cyst Concentration

Giardia Inactivation	<u>3-log</u>	<u>4-log</u>	<u>5-log</u>
Allowable daily avg cyst concentration/100 L (geometric mean)	≤1	>1-10	>10-100

¹⁸ Rose, 1988.

¹⁹ 10⁻⁴ annual risk per person based on consumption of 2 liters of water daily.

According to these guidelines, systems with sewage and agricultural discharges to the source water should provide treatment to achieve an overall 5-log removal/inactivation of Giardia cysts, while the minimum required 3-log removal/inactivation is sufficient for sources with no significant microbiological contamination from human activities. A 4-log removal/inactivation of cysts should be provided for source waters whose level of microbiological contamination is between these two extremes. The location of discharges or other activities polluting the water supply with respect to the location of the intake should also be considered in determining the level of removal/inactivation needed. For instance, long travel times and substantial dilution of a discharge will lessen the impact of the discharge on the intake water quality, in which case less of an increase in the overall treatment recommended above, would be warranted. It is important to note that these levels of treatment for different generalized source water characterizations are presented only as guidelines. The Primacy Agency could develop disinfection requirements based on these or other guidelines. It could also require systems with available resources to conduct raw water monitoring for Giardia cyst concentrations to establish the appropriate level of overall treatment and disinfection needed.

The Primacy Agency may also review the nature of occurrence of Giardia-sized particles in the raw water supply and the association with turbidity occurrence. If it can be demonstrated that a higher degree of removal of particles in the size range of Giardia is accomplished when turbidity levels and associated Giardia levels are elevated, then a log removal credit higher than 3 could be allowed for that particular treatment plant, during such occurrences. This credit should correspond to the log particle removal efficiencies accomplished, as determined by particle counting data, or turbidity data if properly qualified. In all cases, a minimum of 0.5 log reduction of Giardia should be achieved by disinfection in addition to the removal credit allowed for by other treatment.

Until a risk analysis for exposure to viruses is developed, a rough guideline for virus removal/inactivation, can be considered as follows:

- a. For a 4-log Giardia cyst removal/inactivation, a 5-log virus removal/inactivation is recommended.
- b. For 5-log Giardia removal/inactivation, a 6-log virus removal/inactivation is recommended.

These guidelines assume that virus occurrence in the source water is roughly proportional to Giardia cyst occurrence, and that

- viruses occur at higher concentrations in source waters, or
- are more infectious than Giardia cysts and
- infections from viruses may have more health risk significance than Giardia cysts.

Based on these assumptions, higher levels of protection are warranted.

To meet the levels of inactivation recommended here, significant changes in the system may be required. To avoid changes in the system which may result in conflicts with future regulations, the Primacy Agency may wish to establish interim disinfection levels to provide protection of the public health prior to the promulgation of the disinfection by-product regulations and then reconsider whether these levels are still appropriate after the disinfection by-product regulations are promulgated. Guidance for establishing interim disinfection requirements is provided in Section 5.5.

4.4.3 Total Trihalomethane (TTHM) Regulations

In addition to complying with disinfection requirements, systems must meet the requirements of the TTHM regulations. Currently, this regulation includes an MCL for TTHMs of 0.10 mg/L for systems which serve greater than 10,000 people. EPA expects to issue new regulations with a lower MCL in the near future. These regulations may also pertain to systems serving less than 10,000 people. Therefore, the selection of an appropriate disinfectant or disinfection strategy must include consideration of current and future regulations.

5. CRITERIA FOR DETERMINING IF FILTRATION AND DISINFECTION ARE SATISFACTORILY PRACTICED

5.1 Introduction

Under the SWTR, new and existing filtration plants must meet specified monitoring and performance criteria in order to assure that filtration and disinfection are satisfactorily practiced. These criteria include:

- Turbidity monitoring requirements
- Turbidity performance criteria
- Disinfection monitoring requirements
- Disinfection performance criteria

The overall objective of these criteria is to provide control of: Giardia cysts; viruses; turbidity; HPC; and Legionella by assuring a high probability that:

- a. Filtration plants are well-operated and achieve maximum removal efficiencies of the above parameters.
- b. Disinfection will provide adequate inactivation of Giardia cysts, viruses, HPC and Legionella.

5.2 Turbidity Monitoring Requirements

5.2.1 Sampling Location

The purpose of the turbidity requirements for systems which use filtration is to indicate:

- a. Giardia cyst and general particulate removal for conventional treatment and direct filtration
- b. General particulate removal for diatomaceous earth filtration and slow sand filtration
- c. Possible interference with disinfection for all filtration processes

To accomplish the purposes of the turbidity requirements, the SWTR requires that the turbidity samples be representative of the system's

filtered water. The sampling locations which would satisfy this requirement include:

- a. Combined filter effluent prior to entry into a clearwell,
- b. Clearwell effluent;
- c. Plant effluent or immediately prior to entry into the distribution system; or
- d. Average of measurements from each filter effluent.

The selection of sampling locations for demonstrating compliance with the turbidity performance criteria is left to the system or the preference of the Primacy Agency.

5.2.2 Sampling Frequency

The turbidity of the filtered water must be determined:

- a. At least once every four hours that the system is in operation, or
- b. The Primacy Agency may reduce the sampling frequency to once per day for systems using slow sand filtration or filtration treatment other than conventional treatment, direct filtration or diatomaceous earth filtration, if it determines that less frequent monitoring is sufficient to indicate effective filtration performance. For systems serving 500 or fewer people, the Primacy Agency may reduce the sampling frequency to once per day regardless of the type of filtration used if it determines that less frequent monitoring is sufficient to indicate effective filtration performance.

A system may substitute continuous turbidity monitoring for grab sample monitoring if it validates the continuous measurement for accuracy on a regular basis using a protocol approved by the Primacy Agency. EPA recommends that the calibration of continuous turbidity monitors be verified at least twice per week according to the procedures established in Method 214A of the 16th Edition of Standard Methods.¹

¹ Although the 17th Edition of Standard Methods is available, the 16th Edition is referred to in the SWTR. Continuous turbidity monitors must be installed properly to prevent air bubbles from reaching the monitor.

5.2.3 Additional Monitoring

As indicated in Section 4.3.2, EPA recommends that systems equip each filter with a continuous turbidity monitor. This recommendation is not part of the requirements of the SWTR and is not required for establishing compliance. Rather, it is recommended as a tool for systems to use to better monitor their treatment efficiency and to provide a method for detecting a deterioration in filter performance.

If continuous monitoring of each filter effluent cannot be implemented, then EPA recommends that at least the following be conducted on a quarterly basis:

- a. Monitor each filter, either by grab samples or continuous monitors, through the course of a routine cycle of operation, i.e.: from restart to backwash
- b. Visually inspect each filter where appropriate for indications of physical deterioration of the filter

These are general suggestions. The Primacy Agencies are encouraged to work with the systems to determine the best overall monitoring program(s) for their particular filtration plants in order to assess the status of the filter units. Each filter within a system should be maintained so that each filter effluent meets the turbidity performance criteria for the combined filter effluent (i.e., the turbidity limits specified in the SWTR).

5.3 Turbidity Performance Criteria

The SWTR establishes turbidity performance criteria for each of the filtration technologies. As previously indicated, these criteria provide an indication of:

- a. Effective particle and microbial removal
- b. Potential for interference with disinfection

In filtration, effective particle removal depends on both physical and chemical factors. The particles to be removed must be transported to the surface of the media and they must attach to the media. When efficient particle removal does not occur, the deterioration of filter

performance can be due to either physical problems with the filters or problems with the treatment chemistry.

Physical problems which can result in a deterioration of filter performance include:

- a. Media loss
- b. Media deterioration
- c. Mud ball formation
- d. Channeling or surface cracking
- e. Underdrain failure
- f. Cross-connections

In addition, the treatment chemistry has a significant impact on filtration. Specifically, effective particle removal is a function of the:

- a. Raw water chemistry and the changes induced by the chemicals added
- b. Surface chemistry of the particles to be removed
- c. Surface chemistry of the media

Consequently, when a filter experiences particle or turbidity breakthrough prior to the development of terminal headloss, the search for alternatives to correct the problem must include not only an evaluation of the potential physical causes but the treatment chemistry as well. Generally this involves an evaluation of one or more of the following:

- a. Alternate coagulant type and/or dose
- b. Alternate coagulant aid or flocculant aid type and/or dose
- c. Need for an alternate oxidant type and/or dose
- d. Need for a filter aid or alternate dose

5.3.1 Conventional Treatment or Direct Filtration

The minimum turbidity performance criteria for systems using conventional treatment or direct filtration are:

- a. Filtered water turbidity must be less than or equal to 0.5 NTU in 95 percent of the measurements taken every month.
- b. Filtered water turbidity levels of less than or equal to 1 NTU in 95 percent of the measurements taken every month may be permitted on a case-by-case basis if the Primacy Agency determines that the system (filtration with disinfection) is capable of achieving the minimum overall performance requirements of 99.9 percent removal/inactivation of Giardia cysts at the higher turbidity level. Such a determination could be based upon an analysis of existing design and operating conditions and/or performance relative to certain water quality characteristics. The design and operating conditions to be reviewed include:
 - the adequacy of treatment prior to filtration,
 - the percent turbidity removal across the treatment train, and
 - level of disinfection.

Water quality analysis which may also be used to evaluate the treatment effectiveness include particle size counting before and after the filter. Pilot plant challenge studies simulating full scale operation may also be used to demonstrate effective treatment. Depending on the source water quality and system size, the Primacy Agency will determine the extent of the analysis and whether a pilot plant demonstration is needed. For this demonstration, systems are allowed to include disinfection in the determination of the overall performance by the system.²

- c. Filtered water turbidity may not exceed 5 NTU at any time.

The Primacy Agency can assume that conventional treatment plants that are meeting the minimum performance criteria are achieving at least a 2.5-log removal of Giardia cysts and at least a 2-log removal of viruses prior to disinfection.³

² Recommended protocol for this demonstration is presented in Appendix M.

³ The literature indicates that well operated conventional treatment plants can achieve up to 3-log reduction of Giardia cysts and viruses (Logsdson, 1987b and Roebeck et al., 1962). Limiting the credit to 2.5-logs for Giardia cysts and 2-logs for viruses provides a margin of safety by requiring more disinfection. This is consistent with the

The Primacy Agency can assume that direct filtration plants that are meeting the minimum performance criteria are achieving at least a 2-log removal of Giardia cysts and a 1-log removal of viruses.⁴

Although the minimum turbidity performance criterion allows for a maximum filtered water turbidity of 0.5 NTU, treatment facilities using conventional treatment or direct filtration, whose raw water supplies have turbidity levels of 1 NTU or less, should be encouraged to achieve filtered water turbidity levels of less than 0.2 NTU.⁵

Primacy Agencies may allow systems which believe that they are actually achieving greater than a 2- or 2.5-log Giardia cyst removal to demonstrate the actual removal achieved using the protocol outlined in Appendix M. It is reasonable to expect that systems using conventional treatment for high turbidity source water (e.g., turbidities in excess of 100 NTU), and which optimize chemical treatment prior to filtration, may be achieving a 3-log or greater Giardia cyst removal if their filter effluent is substantially below the 0.5 NTU turbidity limit. Softening plants using conventional processes and 2-stage treatment processes may also achieve a 3-log Giardia cyst removal/inactivation. The high pH of softening may result in inactivation of Giardia cysts and viruses which can be demonstrated according to the protocol outlined in Appendix G. Appendix M can be used to demonstrate the Giardia cyst removal achieved.

multiple barrier concept.

⁴ Literature indicates that well operated direct filtration plants can achieve up to a 3-log removal of Giardia cysts and up to a 2-log removal of viruses (Logsdon, 1987b; Roebeck et al., 1962). Limiting the credit to 2-log for Giardia cysts and 1-log for viruses provides a margin of safety by requiring more disinfection. This is consistent with the multiple barrier concept.

⁵ Research has demonstrated that filter effluent turbidities substantially lower than 0.5 NTU are needed to obtain effective removals of Giardia cysts and viruses with low turbidity source waters (Logsdon, 1987b; Al-Ani et al., 1985).

5.3.2 Slow Sand Filtration

For systems using slow sand filtration, the turbidity performance requirements are:

- a. The filtered water turbidity must be less than or equal to 1 NTU in 95 percent of the measurements for each month.
- b. At the discretion of the Primacy Agency, a higher filter effluent turbidity may be allowed for well operated plants (Section 4.3.5) on a case-by-case basis, if there is no interference with disinfection and the turbidity level never exceeds 5 NTU. Noninterference with disinfection could be assumed if the finished water entering the distribution system is meeting the coliform MCL and HPC levels are less than 10/ml during times of highest turbidity.
- c. Filtered water turbidity may not exceed 5 NTU at any time.

Slow sand filtration plants, with appropriate design and operating conditions and which meet the minimum turbidity performance criteria can be considered to be well operated and achieving at least a 2-log removal of Giardia cysts and 2-log removal of viruses without disinfection.⁶ Primacy Agencies may allow systems which believe that they are actually achieving greater than a 2-log Giardia cyst removal to demonstrate the actual removal achieved using the protocol outlined in Appendix M.

5.3.3 Diatomaceous Earth Filtration

For systems using diatomaceous earth filtration, the turbidity performance criteria are:

- a. The filtered water turbidity must be less than or equal to 1 NTU in 95 percent of the measurements for each month.
- b. The turbidity level of representative samples of filtered water must at no time exceed 5 NTU.

Diatomaceous earth systems, with appropriate design and operating conditions and which meet the minimum turbidity performance criterion can

⁶ As indicated in Section 4, pilot studies have shown that with proper nurturing of the schmutzdecke, operation at a maximum loading rate of 0.2 m/hr will provide optimum removal of Giardia cysts and viruses (Logsdon, 1987b; Bellamy et al., 1985).

be considered to be well operated and achieving at least 2-log removal of Giardia cysts and at least 1-log removal of viruses without disinfection. Systems which believe that they are actually achieving greater than a 2-log Giardia cyst removal may demonstrate the actual removal achieved using the protocol outlined in Appendix M.

5.3.4 Other Filtration Technologies

The turbidity performance criteria for filtration technologies other than those presented above, are the same as for slow sand filtration. The Giardia cyst removal achieved by these systems must be demonstrated to the Primacy Agency. The protocol outlined in Appendix M may be used as a basis for this demonstration.

Reverse osmosis is a membrane filtration method used to remove dissolved solids from water supplies. Desalination is a typical use of the process. Application to potable water treatment is limited to extremely high quality raw water supplies of low turbidity (1 NTU or less), or following pretreatment to produce a supply of low turbidity.

The membrane excludes particles larger than 0.001 to 0.0001 um range, thereby effectively removing bacteria, Giardia cysts and viruses. Credit can be given for at least a 3-log Giardia cyst and 4-log virus removal, with no demonstration. It should be noted that this removal credit assumes the membranes are in tact with no holes in the membranes allowing the passage of organisms.

5.4 Disinfection Monitoring Requirements

Each system must continuously monitor the disinfectant residual of the water as it enters the distribution system and record the lowest disinfectant residual each day. If there is a failure in the continuous monitoring equipment, the system may substitute grab sample monitoring every 4 hours for up to 5 working days following the equipment failure. Systems serving 3300 people or fewer may take grab samples in lieu of continuous monitoring at frequencies as follows:

<u>System Population</u>	<u>Samples/Day</u>
≤500	1
501-1,000	2
1,001 - 2,500	3
2,501 - 3,300	4

The grab samples must be taken at different times during the day, with the sampling intervals subject to Primacy Agency review and approval. If the residual concentration falls below 0.2 mg/L, the system must take another sample within 4-hours and notify the Primacy Agency as soon as possible, but no later than the end of the next business day, even if the residual is restored to 0.2 mg/L or greater within 4 hours. If the residual is not restored to 0.2 mg/L or greater within 4 hours, the system is in violation of a treatment technique requirement. Each system must also measure the disinfectant residual in the distribution system at the same frequency and locations at which total coliform measurements are made pursuant to the requirements in the revised Total Coliform Rule (54 FR 27544; June 29, 1989). For systems which use both surface and ground water sources, the Primacy Agency may allow substitute sampling sites which are more representative of the treated surface water supply.

5.5 Disinfection Performance Criteria

5.5.1 Minimum Performance Criteria Required by the SWTR

For systems which provide filtration, the disinfection requirements of the SWTR are:

- a. Disinfection must be provided to ensure that the total treatment processes of the system (including filtration) achieves at least a 3-log removal/inactivation of Giardia cyst and a 4-log removal/inactivation of viruses. The Primacy Agency must determine what level of disinfection is required for each system to meet this criterion.
- b. The system must demonstrate by continuous monitoring and recording that a disinfectant residual in the water entering the distribution system is never less than 0.2 mg/L for more than 4 hours. If at any time the residual falls below 0.2 mg/L for more than 4 hours the system is in violation. The

system must notify the Primacy Agency whenever the residual falls below 0.2 mg/L before the end of the next business day.

- c. The system must demonstrate detectable disinfectant residuals or HPC levels of 500 or fewer colonies/ml in at least 95 percent of the samples from the distribution system each month for any two consecutive months.

5.5.2 Recommended Performance Criteria

Disinfection must be applied to assure that the overall treatment provided achieves at least a 3-log removal/inactivation of Giardia cyst and a 4-log removal/inactivation of viruses. As outlined in Section 5.3, well operated filter plants achieve at least a 2 to 2.5-log removal of Giardia cysts and between a 1 to 2-log removal of viruses. EPA therefore recommends that the Primacy Agencies adopt additional disinfection performance criteria that include:

- a. As a minimum, primary disinfection requirements that are consistent with the overall treatment requirements of the SWTR, or preferably;
- b. Primary disinfection requirements as a function of raw water quality as outlined in Section 4.4.

Recommended Minimum Disinfection

The required minimum primary disinfection is the disinfection needed for the entire treatment process to meet the overall treatment requirement of 3-log Giardia and 4-log virus removal/inactivation. The following table provides a summary of the expected minimum level of treatment performance in well operated filter systems and the recommended level of disinfection.

<u>Filtration</u>	<u>Expected Log Removals</u>		<u>Recommended Disinfection (Log Inactivations)</u>	
	<u>Giardia</u>	<u>Viruses</u>	<u>Giardia</u>	<u>Viruses</u>
Conventional	2.5	2.0	0.5	2.0
Direct	2.0	1.0	1.0	3.0
Slow Sand	2.0	2.0	1.0	2.0
Diatomaceous Earth	2.0	1.0	1.0	3.0

In cases where the system believes that the treatment processes are achieving greater removals than those listed above, the actual removal provided by the processes can be demonstrated through the procedures outlined in Appendix M. However, EPA recommends that, despite the removals demonstrated, systems should provide a minimum of 0.5 log Giardia cyst inactivation to supplement filtration and maintain a second treatment barrier for microorganisms.

Recommended Disinfection as a Function of Raw Water Quality

Although the SWTR requires the overall treatment to provide a minimum of a 3-log Giardia cyst and a 4-log virus removal/inactivation, it may be appropriate for the Primacy Agency to require greater removals/inactivations depending on the degree of contamination in the source water as presented in Section 4.4. Following is a summary of the recommended overall treatment which should be provided based on an estimate of the Giardia cyst concentration in the source water:

Allowable daily avg cyst concentration/100 L (geometric mean)	<u><1</u>	<u>>1-10</u>	<u>>10-100</u>
<u>Giardia</u> cyst Removal/Inactivation	3-log	4-log	5-log
Virus Removal/Inactivation	4-log	5-log	6-log

If a slow sand filtration plant must achieve a 4-log removal/inactivation of Giardia cysts and a 5-log removal/inactivation of viruses, and credit for 2-log Giardia cyst and 2-log virus removal by filtration is granted, disinfection for a 2-log Giardia cyst inactivation and 3-log virus inactivation would be needed to meet the overall removal/inactivation. However, Primacy Agencies may allow systems which use particle size analysis outlined in Appendix M to demonstrate greater than a 2-log Giardia cyst removal to provide less than 2-log Giardia cyst inactivation through disinfection.

5.5.3 Disinfection By-Product Considerations

Although the EPA suggests increased levels of disinfection for various source water conditions, a utility should not implement such a change without considering the potential conflict with the requirements of existing or future disinfection by-product regulations. EPA intends to promulgate National Primary Drinking Water Regulations to regulate levels of disinfectants and disinfection by-products when it promulgates disinfection requirements for ground water systems (anticipated in 1992). EPA is concerned that changes required in utilities' disinfection practices to meet the recommended inactivations for the SWTR might be inconsistent with treatment changes needed to comply with the forthcoming regulations for disinfectants and disinfection by-products. For this reason, EPA recommends that Primacy Agencies exercise discretion, sensitive to potential disinfection by-product concerns, in determining the level of disinfection needed for filtered systems to meet the overall treatment requirements specified in the rule or recommended based on source water quality.

Until the promulgation of the disinfection by-product regulation, EPA recommends that the Primacy Agency allow more credit for Giardia cyst and virus removal by filtration than otherwise recommended if a) the Primacy Agency determines that a system is not currently at a significant risk from microbiological contamination at the existing level of disinfection and b) less stringent interim disinfection conditions are necessary for the system to modify its disinfection process to optimally achieve compliance with the SWTR as well as the forthcoming disinfection by-product regulations. The following paragraphs outline the recommended disinfection levels for systems meeting the above conditions.

For well-operated conventional filtration plants that meet the minimum turbidity requirements at all times, the Primacy Agency may consider giving the system credit for 3-log Giardia cyst removal (in lieu of the generally recommended 2.5-log credit). Also, for well-operated direct filtration plants, the Primacy Agency may consider giving the system credit for 2.5-log Giardia cyst removal in lieu of the generally

recommended 2.0-log credit. EPA recommends that these additional credits be given for conventional or direct filtration only if:

- a. The total treatment train achieves 1) at least 99 percent turbidity removal, or filtered water turbidities are consistently less than 0.5 NTU, whichever is lower,⁷ or 2) a 99.9 percent removal of particles in the size range of 5 to 15 μm is demonstrated as outlined in Appendix M;⁸ and
- b. The level of heterotrophic plate count (HPC) bacteria in the finished (disinfected) water entering the distribution system is consistently less than 10/ml.

Systems using slow sand filtration or diatomaceous earth filtration may be given interim credit for up to 3-log Giardia cyst removal if the system meets the recommended conditions listed above for conventional systems. Pilot plant studies have demonstrated that these technologies, when well operated, generally achieve at least 3.0-log removals (USEPA, 1988a).

The EPA believes that interim level of disinfection requirements may be appropriate in some cases depending upon source water quality, reliability of system operation and potential increased health risks from disinfection by-products. EPA intends to regulate disinfectants and disinfection by-products in 1992. At this time it will become apparent how systems with disinfection by-product problems can optimally meet the disinfection requirements of the SWTR and the disinfection by-products regulations, concurrently.

⁷ For example, a system with a raw water turbidity averaging 20 NTU maintaining a filtered water turbidity less than 0.2 NTU can be granted 3-log Giardia cyst removal credit with no further demonstration.

⁸ In cases where the Primacy Agency has a data base which shows a correlation between turbidity and Giardia cysts removal, turbidity may be used in lieu of particle size analysis. Turbidity removal requirements should be set to assure 99.9 percent Giardia cyst removal. A correlation between turbidity and Giardia cyst removal was shown in a study reported by Hendricks et al (1984).

5.5.4 Recommended Disinfection System Redundancy

The SWTR does not require a redundant disinfection system for filtered supplies. However, in order to assure the continuous provision of disinfection to meet the overall removal/inactivation requirements and to maintain a residual entering the distribution system, EPA recommends that redundant disinfection equipment be provided. As contained in the 1987 edition of Ten State Standards, where disinfection is required for protection of the supply, standby equipment is required. Automatic switchover should be provided as needed, to assure continuous disinfectant application.

Recommendations for providing redundant disinfection are outlined in Section 3.2.4 and detailed in Appendix I.

5.5.5 Determination of Inactivation by Disinfection

The desired level of inactivation can be achieved by disinfection at any point in the treatment or distribution system prior to the first customer. Disinfection provided prior to filtration is referred to as pre-disinfection while disinfection after filtration is referred to as post-disinfection. As presented in Section 3.2, the inactivation of Giardia cysts and viruses provided by disinfection are indicated by CT values.

The SWTR defines CT as the residual disinfectant concentration(s) in mg/L multiplied by the contact time(s) in minutes. The contact time is measured from the point of disinfectant application to the point of residual measurement or between points of residual measurement. The inactivation efficiency can be determined by calculating CT at any point along the process after disinfectant application prior to the first customer.

A system may determine the inactivation efficiency based on one point of residual measurement prior to the first customer, or on a profile of the residual concentration after the point of disinfectant application. The residual profile is generated by monitoring the residual at several points between the point(s) of disinfectant application and the first customer. The system can then use the method described in Section 3.2 for determining the total inactivation credit. Profiling the residual allows

for credit of significantly higher residuals which may exist before the water reaches the first customer. Methods for determining various disinfectant residuals are described in Appendix D.

In pipelines, the contact time can be assumed equivalent to the hydraulic detention time and is calculated by dividing the internal volume of the pipeline by the peak hourly flow rate through the pipeline. In mixing basins and storage reservoirs, the hydraulic detention time generally does not represent the actual disinfectant contact time because of short circuiting. The contact time in such chambers should be determined by tracer studies or an equivalent demonstration. The time determined from the tracer study to be used for calculating CT is T_{10} . T_{10} represents the time that 90 percent of the water (and microorganisms within the water) will be exposed to disinfection within the disinfectant contact chamber. Guidance for determining detention time in contact chambers is provided in Appendix C.

The residual disinfectant concentration should be measured daily, during peak hourly flow, for each disinfectant section prior to the first customer in the distribution system. Unless a system knows from experience when peak flow will occur, a system can only identify peak hourly flow after it has occurred. Therefore, EPA suggests that residual measurements be taken every hour. If it is not practical to take grab samples each hour, the system may take grab samples during the period peak flow is expected to occur, or continuous monitors may be used. The measurements taken during the hour of peak flow can then be used to determine the CT for each section (CT_{calc}). The determination of CTs is explained in Section 3.2.1.

Although the inactivation maintained in the system is determined during peak hourly flow, the disinfectant dosage applied to maintain this inactivation may not be necessary under lower flow conditions. Under lower flow conditions, a higher contact time is generally available and the CT needed to meet the required inactivation may be met with a lower residual concentration. Continuing to apply a disinfectant dosage based on the peak hourly flow may provide more disinfection than is needed, increasing costs and possibly resulting in increased levels of disinfectant by-products. However, the system should also maintain the required

inactivation levels at non-peak hourly flows. The system should therefore evaluate the dose needed to provide the CT necessary for maintaining the required inactivation under different flow conditions and set the dosage accordingly. The following example provides guidelines for determining flow ranges and disinfection levels to maintain the required disinfection.

Example

A 20-mgd direct filtration plant applying free chlorine as a disinfectant has a contact time of 27.5 minutes under peak flow conditions. As noted in Section 5.3, well-operated direct filtration plants achieve 2-log Giardia cyst removal and 1-log virus removal. Therefore, disinfection for 1-log Giardia cyst inactivation and 3-log virus inactivation is recommended. The pH and temperature of the water are 7 and 5 C, respectively. Using Table E-2, a CT of 55 is required to achieve 1-log Giardia cyst inactivation at a residual of 2 mg/L. This level of treatment is more than adequate for 3-log inactivation of viruses requiring a CT of 6, as indicated in Table E-7. However, under low flow conditions the available contact time is longer, and lower residuals are needed to provide the same level of inactivation. Based on the calculated contact time under various flow rates and the CT values in Table E-2, adequate disinfection would be provided by maintaining the following chlorine residuals for the indicated flows:

<u>Flow (MGD)</u>	<u>Contact the (min)</u>	<u>CT₉₀ (mg/L-min) Required</u>	<u>Free Chlorine Residual (mg/L)</u>
20	27.5	55	2.0
15	36	52.5	1.5
10	54	50	1.0
5	108	47	0.5

CT₉₀ corresponds to a 1-log inactivation. If a different level of inactivation were needed, CT values for that inactivation would be read from the tables corresponding to the pH and temperature of the water.

- Section 3.2.2 lists the percent inactivations corresponding to log inactivations, i.e., 0.5-log equals 68 percent requiring CT₆₈.

- In cases where the residual, pH or temperature of the water is an intermediate value not reported in the tables, linear (straight-line) interpolation may be used.
- For example, in the above listing, 0.5 mg/L residuals are not included in the Appendix E tables. The CT_{90} value was determined by interpolating between the ≤ 0.4 mg/L value of 46 mg/L-min and the 0.6 mg/L value of 48 mg/L-min.
- CT values for intermediate pH and temperature values may also be interpolated; or
- The CT values for the higher pH or lower temperature listed in the table may be used instead of interpolation.
- $CT_{99.9}$ tables in the SWTR can be used to calculate the CT required to achieve any log inactivation by:

$$CT_{\text{required}} = \frac{\text{log inactivation required}}{3.0 \text{ log}} \times CT_{99.9}$$

The variation in CT required with respect to the residual for chlorine makes it impractical for the utility to continually change the disinfectant dose as the flow changes. Therefore, EPA suggests that the flow variation at the utility be divided into ranges and the residual needed at the higher flow of the range be maintained for all flows within the range to assure adequate disinfection. The following flow ranges and residuals at the given pH and temperature are suggested for this plant:

<u>Flow Range (MGD)</u>	<u>Free Chlorine Residual (mg/L)</u>
5-10	1.0
10-15	1.5
15-20	2.0

In this way, the utility is assuring the provision of the required disinfection while minimizing the disinfectant costs and possibly lowering disinfection by-products.

Although these residuals will meet the required CT, maintaining a residual in the distribution system must also be considered. If there is no other point of disinfection prior to the distribution system, the residual for disinfection must be maintained at a level which will also

provide a residual throughout the distribution system. The complete range of flows occurring at the plant should be evaluated for determining the required residual. The utilities may establish the residual needs for as many flow ranges as is practical.

The Primacy Agency should make periodic checks to assure that the utility is maintaining adequate disinfection at both peak and non-peak flow conditions.

In contrast to this close control of disinfectant addition and CT monitoring, for filtered systems which have long detention times and regularly exceed the CT requirements for the inactivation needed, it may be unnecessary for the system to calculate CTs each day of operation. Unlike unfiltered systems where CTs must be calculated each day, for filtered systems, monitoring the residual at the end of the contact time may be sufficient to indicate that the required disinfection is provided. However, this results in much higher CTs in the summer than is needed, which adds to costs and possibly unnecessary increased production of disinfection by-products. The following example outlines one scenario for which this would apply.

Example

A utility disinfects with chlorine ahead of a reservoir prior to direct filtration. The Primacy Agency may give a well-operated direct filtration plant credit for 2-log Giardia cyst removal and 1-log virus removal. Therefore, 1-log Giardia cyst and 3-log virus inactivation through disinfection is needed. For free chlorine, the CTs for 1-log Giardia cyst inactivation exceed the CTs for 3-log virus inactivation. Therefore, CTs for Giardia cyst inactivation are the controlling CTs. The following water quality conditions occur in the reservoir during the year:

pH	7 - 7.5
Temperature (° C)	5 - 20
Chlorine residual (mg/L)	0.2 - 0.8

The required CT for chlorine increases with:

- increasing residual,
- increasing pH, and
- decreasing temperature

Thus, for a residual of 0.8 mg/L the CT needed for a 1-log Giardia cyst inactivation is as follows:

<u>pH</u>	<u>Temperature (C)</u>	<u>CT₉₀ mg/L-min</u>
7.5	5	58 (Table E-2)
7	20	18 (Table E-5)

Tracer studies conducted on the reservoir indicated a T₁₀ of 150 minutes at the system's maximum flow. For the maximum CT of 58 mg/L-min required, the minimum residual needed to meet this requirement is 0.4 mg/L, calculated as:

$$\frac{58 \text{ mg/L-min}}{150 \text{ min}} = 0.4 \text{ mg/L}$$

At a residual of 0.4 mg/L, CT₉₀ is 55 mg/L-min. Thus, any residual ≥0.4 mg/L will provide the needed disinfection throughout the year and the Primacy Agency may require the system to report only the residual maintained, reducing the effort needed to determine effective disinfection. Maintaining this residual in the summer, however, provides much higher CTs than needed, possibly resulting in unnecessary costs and increased disinfection by-products.

Meeting the Recommended Inactivation Using Free Chlorine

As previously indicated in Section 3.2.1, the effectiveness of free chlorine as a disinfectant is influenced by both the temperature and pH of the water and by the concentration of chlorine. The inactivation of Giardia cysts by free chlorine at various temperatures and pHs are presented in Appendix E (Table E-1 through Table E-6). The CT values for the inactivation of viruses by free chlorine are presented in Table E-7.

To determine whether a system is meeting these inactivations, the free chlorine residual, pH and temperature must be measured, at one point or several points prior to the first customer, where contact time(s) is measured. The contact time should be determined from the point of application of the disinfectant to the point(s) where the residual is measured for determining CTs prior to the first customer. The CTs

actually achieved in the system should then be compared to the values in the table for the pH and temperature of the water at the point(s) of residual measurement. Guidance on calculating the CT for chlorine is presented in Section 3.2.1.

Meeting the Recommended Inactivation Using Chlorine Dioxide

CT values for the inactivation of Giardia cysts by chlorine dioxide are presented in Table E-8 and the CT values for the inactivation of viruses are presented in Table E-9. As shown in Tables E-8 and E-9, the only parameter affecting the CT requirements for chlorine dioxide is temperature. However, the disinfection efficiency of chlorine dioxide may be significantly increased at higher pHs. Since the CT values in Tables E-8 and E-9 were based on data at pH 7 and 6, respectively, and chlorine dioxide appears to be more effective at higher pHs, systems with high pHs may wish to demonstrate that CT values lower than those presented in Tables E-8 and E-9 may achieve the desired level of inactivation.

Chlorine dioxide residuals are short-lived. Therefore, sampling and residual analysis at various points in the treatment process downstream of the point of application may be necessary to establish the last point at which a residual is present. Subsequent sampling and residual analyses conducted upstream of this point can be used to determine the CT credit by using the demonstrated detention time between the point of application and the sampling location. Methods for calculating CT values are presented in Section 3.2. Systems using chlorine dioxide may conduct pilot studies to demonstrate effective disinfection in lieu of calculating CT, or for determining that lower CT values than those in Appendix E are appropriate. Guidelines for conducting these studies are presented in Appendix G.

Meeting the Recommended Inactivation using Ozone

CT values for the inactivation of Giardia cysts by ozone are presented in Table E-10 for various temperatures and inactivation rates. As indicated in this table, the CTs required for inactivation with ozone are substantially lower than those required for free chlorine. This reflects the fact that ozone is a more powerful disinfectant. The CT requirements for inactivation of viruses using ozone are presented in Table E-11. In cases where only a 1-log or lower Giardia cyst inactivation is needed, the CT values for virus inactivation may be higher than

the CTs for Giardia cysts. Because of the reactivity of ozone, it is unlikely that a residual will exist for more than a few minutes. As a result, the application of a persistent disinfectant such as chlorine or chloramines is needed to maintain the required disinfectant residual in the distribution system. Guidance for calculating CT values for ozone are presented in Section 3.2.1 and Appendix O. In lieu of calculating the CT for an ozone contactor or demonstrating that lower CTs are effective, the disinfection efficiency can be demonstrated through pilot studies as presented in Appendix G.

Meeting the Recommended Inactivation Requirements using Chloramines

CT values for the inactivation of Giardia cysts by chloramines are presented in Table E-12. The high CT values associated with the use of chloramines may be unachievable for some systems. In these cases, chlorine, ozone, or chlorine dioxide should be used for primary disinfection, and chloramines for residual disinfection, as necessary. Table E-13 presents CT values for the inactivation of viruses with chloramines. This table is only applicable for indicating virus inactivation efficiencies if chlorine is added prior to ammonia. Systems which add ammonia prior to chlorine or ammonia and chlorine concurrently, can determine viral inactivation efficiencies using the protocol given in Appendix G. For systems applying chloramines to meet the virus inactivation requirements, EPA recommends that they also monitor for HPC in the finished water, as presented in Section 5.6. Systems also may demonstrate effective disinfection with chloramines in lieu of calculating CT, or to determine that lower CT values than those indicated in Appendix E are appropriate. The protocols outlined in Appendix G can be used for this demonstration. Further guidance on chloramines is given in Section 3.2.1.

Meeting the Inactivation Requirement Using Ultraviolet (UV) Radiation

Ultraviolet radiation is a method of disinfection which can be applied to meet the virus inactivation requirements of the SWTR.

UV disinfectant dose, expressed in terms of UV intensity and exposure time/unit area ($\text{mW}\cdot\text{sec}/\text{cm}^2$) incorporates the elements of the CT concept and therefore can be considered as analogous or equivalent to a CT value. UV disinfection usually employs commercially available units

designed to deliver doses of 25 to 35 mW-sec/cm². The dose can be increased by reducing water flow rate and/or by adding additional units in series. UV disinfection efficiency differs from that of chemical disinfectants in that it is not affected by water temperature. UV radiation does not effectively penetrate solids and is absorbed by certain dissolved substances. Therefore, turbidity and other water quality factors are important determinants of UV disinfection efficiency, and UV should be applied after turbidity removal.

CT values for the inactivation of Giardia cysts by UV are not included in Appendix E. The results of two studies (Rice and Hoff, 1981; Carlson et al, 1985) indicate that Giardia cysts are extremely resistant to inactivation by UV with doses greater than 60 mW-sec/cm² causing less than 80% inactivation. Because UV appears to be very ineffective for Giardia cyst inactivation and in the absence of sufficient data showing the doses needed to inactivate 0.5 to 3.0 logs of cysts, UV must be used in combination with other disinfectants to provide evidence of effective cyst inactivation.

CT values for the inactivation of viruses by UV are presented in Table E-14. Units used for UV disinfection should be equipped with fail-safe devices that will provide automatic shutdown of water flow if UV dose decreases to levels lower than those specified in Table E-14.

Meeting the Inactivation Requirement Using Alternate Disinfectants

For system using disinfectants other than chlorine, chloramines, chlorine dioxide, or ozone, the effectiveness of the disinfectant can be demonstrated using the protocol contained in Appendix G. The protocol in Appendix G.3 for batch testing should be followed for any disinfectant which can be prepared in an aqueous solution and will be stable throughout the testing. For disinfectants which are not stable, the pilot study protocol outlined in Appendix G.4 should be followed.

Examples for Determining the Disinfection to be Provided

1) Recommended 0.5-log Giardia, 2-log Virus Inactivation

A community of 70,000 uses a river as its drinking water source. Ozonation prior to a conventional treatment plant is used to treat the

water. The source has a protected watershed with limited human activity and no sewage discharge. The river water has the following water quality characteristics:

Turbidity	10 - 200 NTU
Total estimated Giardia cyst level	<1/100 /L
pH	7.0 - 7.5
Temperature	5 - 15

The treatment plant has a design capacity of 15 mgd and treats an average flow of 10 mgd. A three chamber ozone contactor precedes the rapid mix. Alum and polymer are added as a coagulant and coagulant aid, respectively. The finished water turbidity at the plant is maintained within the range of 0.1 to 0.2 NTU. Chloramines are applied after the filters, but prior to the clearwells, to maintain a residual entering and throughout the distribution system.

Based on the raw water quality and source water protection, an overall 3-log Giardia cyst and 4-log virus removal/inactivation is appropriate for this water source. However, as noted in Section 5.3, Primacy Agencies may credit well operated conventional filtration plants with 2.5-log Giardia cyst removal and 2-log virus removal. Therefore, disinfection for 0.5-log Giardia cysts and 2-log viruses is recommended to meet the overall treatment requirements of the SWTR.

On the day of this example calculation, the peak hourly flow rate of the plant was 13 mgd. The contact time of the ozone basin, T_{10} determined from tracer study data is 6 minutes for this flow. The water had a pH of 7 and a temperature of 5 C on the day of the calculation. For ozone under these conditions of pH and temperature, the following CTs are needed for the required inactivation (Tables E-10, E-11):

	<u>0.5-log Giardia</u>	<u>2-log virus</u>
CT	0.3	0.6

The CT values indicate that viruses are the controlling parameter for disinfection and the overall inactivation provided will be calculated based on viruses. The overall virus inactivation provided by the ozone contactor is determined as follows:

Average

Chamber	Residual C (mg/L)	T ₁₀ (minutes)	CT _{calc} (mg/L)	CT _{99.9} (mg/L-min.)	CT _{calc} /CT _{99.9}
1	0.1	2	0.2	0.9	0.22
2	0.2	2	0.4	0.9	0.44
3	0.2	2	0.4	0.9	0.44

The sum of CT_{calc}/CT_{99.9} is 1.1. This corresponds to more than a 3-log virus inactivation determined as 3 X CT_{calc}/CT_{99.9} = 3 X 1.1 = 3.3-log. Therefore, the system exceeds the recommended inactivation.

2) Recommended 1-log Giardia Cyst, 2-log Virus Inactivation

A 2 MGD slow sand filtration plant treating reservoir water, fed by mountain streams with no nearby wastewater discharges, provides drinking water for a community of 8,000 people. The water quality at the intake has the following water quality characteristics:

Turbidity	5 - 10 NTU
Total coliforms	Not measured
Total estimated <u>Giardia</u> cyst level	<1/100 L
pH	6.5 - 7.5
Temperature	5 - 15 C

The filtered water turbidity ranges from 0.6 - 0.8 NTU. Considering the source water quality and plant performance, an overall 3-log Giardia cyst and 4-log virus removal/inactivation is considered sufficient for this system. As noted in Section 5.3, the Primacy Agency may credit slow sand plants with 2-log Giardia cyst and 2-log virus removal. Therefore disinfection for 1-log Giardia cyst and 2-log virus inactivation is recommended for the system to meet the overall treatment requirements.

Chlorine is added prior to the clearwells to provide disinfection. The clearwells have a capacity of 80,000 gallons. A one mile, 16-inch transmission main transports the water from the treatment plant to the first customer. The inactivation provided is determined daily for the peak hourly flow conditions. Tracer studies have been conducted to determine the T₁₀ for the clearwells for different flow rates. For the purposes of calculating the inactivation the system is divided into two sections.

Section 1 - clearwell

Section 2 - transmission main

The flowrate at peak hourly flow from the clearwell was 1.5 mgd on the day of this example. At this flowrate, the T_{10} of the clearwell is 67 minutes, as determined from the results of the tracer studies. At this flowrate, water travels through the transmission main at 99 ft/min. The data for the calculation of the inactivation is as follows:

	<u>Section 1</u>	<u>Section 2</u>
length of pipe (ft)	0	5280
contact time (min)		
pipe	0	53
basin	67	0
total	67	53
disinfectant	chlorine	chlorine
residual (mg/L)	1.0	0.6
temperature C	5	5
pH	7.5	7.5

For free chlorine, a 1-log Giardia cyst inactivation provides greater than a 4-log virus inactivation; therefore, Giardia cyst inactivation is the controlling parameter, and the inactivation provided is determined based on Giardia cysts. The calculation is as follows:

Section 1 - Chlorine

$$CT_{calc} = 1.0 \text{ mg/L} \times 67 \text{ minutes} = 67 \text{ mg/L-min}$$

From Table E-2, at a temperature of 5 C and a pH of 7.5, $CT_{99.9}$ is 179 mg/L-min

$$CT_{calc}/CT_{99.9} = \frac{67 \text{ mg/L-min}}{179 \text{ mg/L-min}} = 0.37$$

Section 2 - Chlorine

$$CT_{calc} = 0.6 \text{ mg/L} \times 53 \text{ minutes} = 32 \text{ mg/L-min}$$

From Table E-2, at a temperature of 5 C and a pH of 7.5, $CT_{99.9}$ is 171 mg/L-min

$$CT_{calc}/CT_{99.9} = \frac{32 \text{ mg/L-min}}{171 \text{ mg/L-min}} = 0.19$$

The sum of $CT_{calc}/CT_{99.9}$ is equal to 0.56. This is equivalent to a 1.7-log Giardia cyst inactivation determined as $3\text{-log} \times CT_{calc}/CT_{99.9} = 3 \times 0.56 =$

1.7-logs. Therefore, the system exceeds the disinfection recommended to meet the overall treatment requirements.

3) Recommended 2-log Giardia Cyst, 4-log Virus Inactivation

A community of 30,000 people uses a reservoir treated by direct filtration for its water supply. The reservoir is fed by a river which receives the discharge from a wastewater treatment plant 10 miles upstream of the reservoir. The reservoir water quality is as follows:

Turbidity	5 - 15 NTU
Total coliforms	100 - 1000/100 ml
Total estimated <u>Giardia</u> cyst level	5/100 L
pH	6 - 7
Temperature	5 - 15 C

Based on the source water quality, an overall removal/inactivation of 4-log Giardia cyst and 5-log virus is recommended as outlined in Section 4.4.

The source water flows by gravity to a 3 MG storage reservoir prior to pumping to the water treatment plant. Chloramines are produced by first adding chlorine then ammonia to the water within the inlet of the storage reservoir. Chlorine dioxide is added to the filtered water prior to the clearwells. Chloramines are applied after the clearwells to maintain a residual in the distribution system. The system design flow is 8 mgd with an average flow of 5 mgd. For the calculation of the overall inactivation, the system is divided into 2 sections.

Section 1 - the storage reservoir and the transmission to the treatment plant

Section 2 - the clearwells

The overall inactivation for the system is computed daily at the peak hourly flow conditions. The pH, temperature, and disinfectant residual is measured at the end of each section prior to the next point of disinfectant application and the first customer. The flow is measured in the transmission main entering the plant and exiting the clearwells. On the day of this example calculation, the peak hourly flow was 6 mgd in the transmission mains entering and leaving the plant. If the flowrates were different, the T_{10} corresponding to the respective flowrate would be used

in the calculation. Guidance for determining CTs when flowrates vary within a system is given in Section 3.2. The water velocity through the 20-inch transmission main is 256 ft/min at a flow of 6 mgd. Tracer studies were conducted on the storage reservoir and clearwells. As determined from the testing the detention times, T_{10} , of the basins at a flow of 6 mgd are 380 and 130 minutes for the storage reservoir and clearwells, respectively. The data for the calculation of inactivation is as follows:

	<u>Section 1</u>	<u>Section 2</u>
length of pipe (ft)	4500	0
contact time (min)		
pipe	18	0
basin	380	130
total	398	130
disinfectant	chloramines	chlorine dioxide
residual (mg/L)	1.5	0.2
temperature C	5	5
pH	7	7

For each of the disinfectants used, the following CTs are needed for 2-log *Giardia* and 4-log virus inactivation for the pH and temperature conditions of the system.

	<u>CT for 2-log Giardia</u>	<u>CT for 4-log Virus</u>
chloramines	1430	1988
chlorine dioxide	17	33.4

The CT required for the virus inactivation is higher than that needed for Giardia inactivation for each of the disinfectants. Since the viruses are the controlling parameter, the inactivation calculation will be based on the viruses. The calculation is as follows:

Section 1 - Chloramines

$$CT_{calc} = 1.5 \text{ mg/L} \times 398 \text{ minutes} = 597 \text{ mg/L-min}$$

From Table E-13, at a temperature of 5 C and a pH of 7, $CT_{99.99}$ is 1988 mg/L-min

$$CT_{calc}/CT_{99.99} = \frac{597 \text{ mg/L-min}}{1988} = 0.3$$

1988 mg/L-min

Section 2 - Chlorine Dioxide

$$CT_{calc} = 0.2 \text{ mg/L} \times 130 \text{ minutes} = 26 \text{ mg/L-min}$$

From Table E-9, at a temperature of 5 C and a pH of 7, $CT_{99.99}$ is 33.4 mg/L-min

$$CT_{calc}/CT_{99.99} = \frac{26 \text{ mg/L-min}}{33.4 \text{ mg/L-min}} = 0.78$$

The sum of $CT_{calc}/CT_{99.99}$ is equal to 1.08, which is equivalent to a 4.3-log inactivation of viruses, determined as follows:

$$x = 4\text{-log} \times \frac{CT_{calc}}{CT_{99.99}} = 4 \times 1.08 = 4.3\text{-logs}$$

Therefore, the system provides sufficient disinfection to meet the overall recommended treatment performance.

5.6 Other Considerations

Monitoring for heterotrophic plate count (HPC) bacteria is not required under the SWTR. However, such monitoring may provide a good operational tool for:

- Measuring microbial breakthrough
- Evaluating process modifications
- Detecting loss of water main integrity
- Detecting bacterial regrowth conditions within the distribution system
- Determining interference with the coliform measurements (AWWA, 1987)

Therefore, EPA recommends routine monitoring for HPC in the plant effluent and within the distribution system whenever the analytical capability is available in-house or nearby. Systems which do not have this capability should consider using a semi-quantitative bacterial water sampler kit, although this is not acceptable for compliance monitoring.

As discussed in the preamble to the SWTR, EPA believes that it is inappropriate to include HPC as a treatment performance criterion in the rule since small systems would not have in-house analytical capability to conduct the measurement, and they would need to send the samples to a private laboratory. Unless the analysis is conducted rapidly, HPC may multiply and the results may not be representative.

EPA recommends an HPC level of less than 10/ml in the finished water entering the distribution system and levels of less than 500/ml throughout the distribution system.

Legionella is another organism which is not included as a treatment performance criterion. Inactivation information on Legionella is limited. EPA believes that treatment which complies with the SWTR will remove and/or inactivate substantial levels of Legionella which might occur in source waters, thereby reducing chances that Legionella will be transported through the system and reducing the possibility that growth might occur in the distribution system or hot water systems within homes and institutions. Since Legionella are similar in size to coliform organisms, removals by filtration should be similar to those reported for total coliforms. In addition, the available disinfection information indicates that the CT requirements for inactivation of Legionella are lower than those required for the inactivation of Giardia cysts. EPA recognizes, that regardless of the treatment provided, some Legionella may enter plumbing and air conditioning systems and subsequently multiply (Muraca et al., 1986). EPA believes that these concerns are best addressed through guidance contained in Appendix B.

6. REPORTING

6.1 Reporting Requirements for Public Water Systems Not Providing Filtration

The SWTR requires unfiltered systems to prepare monthly reports for the Primacy Agency to determine compliance with the requirements for:

- source water fecal and/or total coliform levels
- source water turbidity levels
- disinfection level
- disinfectant residual entering the distribution system
- disinfectant residuals throughout the distribution system.

The monthly reports must be prepared and submitted to the Primacy Agency within 10 days after the end of the month. The utility must maintain a daily or monthly data log used to prepare the monthly reports. Tables 6-1 through 6-5 are examples of daily data sheets which the utilities may find useful for logging the data needed to prepare reports for the Primacy Agency.

Table 6-6 presents a concise format which can be used by the system for the monthly reports to the Primacy Agency. Tables 6-3 and 6-4 must also be submitted with the monthly report. After the initial 12 months of reporting, the Primacy Agency may remove the requirement for reporting the information contained in Table 6-3 if it is satisfied that the system is computing compliance with the CT requirements correctly. The individual sample results summarized in the monthly reports should be kept on file at the utility for a minimum of 5 years.

In addition to the monthly reporting requirements for source water quality conditions and disinfection information, systems with unfiltered supplies are also required to submit annual reports for the watershed control program and the on-site inspection, within 10 days after the end of the federal fiscal year.

The Primacy Agency will review the reports to determine whether the system is in compliance. A possible report format for the watershed control program is:

1. Summarize all activities in the watershed(s) for the previous year.
2. Identify activities or situations of actual and potential concern in the watershed(s).
3. Describe how the utility is proceeding to address activities creating potential health concerns.

EPA recommends that the Primacy Agency submits the annual watershed reports to the State Water Quality Managers. The reports will be useful in updating statewide assessments and management programs.

The SWTR requires each system to provide the Primacy Agency with a report of the on-site inspection unless the inspection is conducted by the Primacy Agency. EPA suggests that:

1. A report of the inspection containing the findings, suggested improvements and dates by which to complete improvements is to be prepared following the initial system review. When and how system has resolved problems identified in the previous report should also be included.
2. To lessen the burden on utilities, a report containing results of the general survey should be submitted in subsequent years.

In addition to these reporting requirements, the SWTR requires that the reporting requirements of the Total Trihalomethane Regulation and the Coliform Rule also be met.

Records of waterborne disease outbreaks also must be maintained. In the event of a waterborne disease outbreak, as defined in part 141.2 of the SWTR, the Primacy Agency must be notified by the end of the next business day.

The report of the outbreak should contain:

1. Date of occurrence
2. Type of illness
3. Number of cases
4. System conditions at the time of the outbreak, including disinfectant residuals, pH, temperature, turbidity, and bacteriological results.

The records of an outbreak should be maintained permanently or until filtration is installed.

6.2 Reporting Requirements for Public Water Systems Using Filtration

The SWTR requires filtered water systems to submit monthly reports to the Primacy Agency for determination of compliance with the requirements for:

- treated water turbidity
- disinfectant residual entering the distribution system
- disinfectant residuals throughout the distribution system

Tables 6-7 and 6-8 present a format which the utility can use as a daily data log and to submit monthly reports to the Primacy Agency.

Recommended Reporting Not Required by the SWTR

The Primacy Agency may also want filtered water systems to report some information associated with recommendations made in this manual which are not requirements of the SWTR. EPA recommends that filtered water systems:

1. Report the log inactivation of Giardia cysts and viruses, required by the Primacy Agency.
2. Report point of application for all disinfectants used.
3. Report the daily CT(s) used to calculate the log inactivation of Giardia cysts and viruses.
4. If more than one disinfectant is used, report the CT(s) and inactivation(s) achieved for each disinfectant and the total percent inactivation achieved.
5. Note any difference between the measured CT(s) and the CT required to meet the overall minimum treatment performance requirement specified by the Primacy Agency.

Tables 6-3 and 6-4 can be used to maintain the records necessary for numbers 2 through 5.

This information can be used to determine the disinfection level maintained by the system to assure that the overall removal/inactivation required is maintained.

The Primacy Agency may make provisions to minimize the reporting requirements for systems with reservoirs, large amounts of storage or long transmission mains which provide a long disinfectant contact time. Since these systems typically provide inactivation in excess of that needed, the Primacy Agency may require the system only to report the minimum daily residual at the end of the disinfectant contact time. The CT maintained can then be estimated based on this residual and the contact time under the system design flow. This method of CT determination will eliminate the need for the system to determine the contact time under maximum flow conditions each day.

TABLE 6-1

SOURCE WATER QUALITY CONDITIONS FOR UNFILTERED SYSTEMS
(For system use only)

Month _____
Year _____

System/Treatment Plant _____
PWSID _____

Date	2 Coliform Measurements				3 Turbidity Measurements	
	No. of Samples		No. of Samples Meeting Specified Limits		Maximum Turbidity (NTU)	Turbidity "Event" (Yes or No)
	Fecal	Total	Fecal (<= 20/100 mL)	Total (<= 100/100 mL)		
1						
2						
3						
4						
5						
6						
7						
8						
9						
10						
11						
12						
13						
14						
15						
16						
17						
18						
19						
20						
21						
22						
23						
24						
25						
26						
27						
28						
29						
30						
31						
Totals:					Maximum daily turbidity = _____ NTU	Total number of turbidity "events" = _____

- Notes:**
1. Samples are taken from the source water immediately prior to the first disinfection point included in the CT determination.
 2. As specified in 40 CFR 141.74(b)(1), a fecal or total coliform sample must be taken on each day that the system operates and a source water turbidity measurement exceeds 1 NTU.
 3. For each day that the maximum turbidity exceeds 5 NTU, the date should also be entered for the day that the State was notified of this exceedance, e.g., "7.3-22 Apr".
 4. A "yes" response is required each day the maximum turbidity exceeds 5 NTU and the previous day did not. This is indicative of the beginning of a turbidity "event". The total number of "yes" responses equals the number of turbidity "events".

TABLE 6-2

LONG-TERM SOURCE WATER QUALITY CONDITIONS FOR UNFILTERED SYSTEMS
(For system use only)

Year _____ System/Treatment Plant _____
PWSID _____

Month	Coliform Measurements				Turbidity Measurements	
	No. of Samples		No. of Samples Meeting Specified Limits		Days with Turbidity >5 NTU	Number of Turbidity Events
	Fecal	Total	Fecal (<= 20/100 mL)	Total (<= 100/100 mL)		
January						
February						
March						
April						
May						
June						
July						
August						
September						
October						
November						
December						
Total:						

TABLE 6-3

1, 2

CT DETERMINATION FOR UNFILTERED SYSTEMS - MONTHLY REPORT TO PRIMACY AGENCY

Month _____ System/Treatment Plant _____

Year _____ PWSID _____

Disinfectant/Sequence of Application _____

Date	³ Disinfectant Concentration, C (mg/L)	³ Disinfectant Contact Time, T (min.)	⁴ CTcalc (=C x T)	^{3, 5} pH	³ Water Temp. (deg. C)	⁶ CT99.9	(CTcalc/CT99.9)
1							
2							
3							
4							
5							
6							
7							
8							
9							
10							
11							
12							
13							
14							
15							
16							
17							
18							
19							
20							
21							
22							
23							
24							
25							
26							
27							
28							
29							
30							
31							

Prepared by _____
Date _____

Notes:

1. To be included in the monthly report for at least 12 months after the initiation of reporting. After that time, the Primacy Agency may no longer require this form.
2. Use a separate form for each disinfectant/sampling site. Enter disinfectant and sequence position, e.g., "ozone/1st" or "ClO₂/3rd".
3. Measurement taken at peak hourly flow.
4. CTcalc = C (mg/L) x T (min.).
5. Only required if the disinfectant is free chlorine.
6. From Tables 1.1 - 1.6, 2.1, and 3.1, 40 CFR 141.74(b)(3).

TABLE 6-4

DISINFECTION INFORMATION
FOR UNFILTERED SYSTEMS - MONTHLY REPORT TO PRIMACY AGENCY

Month _____
Year _____

System/Treatment Plant _____
PWSID _____

Date	Minimum Disinfectant Residual at Point-of-Entry to Distribution System (mg/L)	(CT _{calc} /CT _{99.9}) (from Table 6-3)						SUM (CT _{calc} /CT _{99.9})	SUM (CT _{calc} /CT _{99.9}) < 1 (Yes or No)
		Disinfectant Sequence							
		1st	2nd	3rd	4th	5th	6th		
1									
2									
3									
4									
5									
6									
7									
8									
9									
10									
11									
12									
13									
14									
15									
16									
17									
18									
19									
20									
21									
22									
23									
24									
25									
26									
27									
28									
29									
30									
31									

Prepared by _____
Date _____

Notes:

1. If less than 0.2 mg/L, the lowest level and duration of the period must be reported, e.g., "0.1-3 hrs."
2. To determine SUM (CT_{calc}/CT_{99.9}), add (CT_{calc}/CT_{99.9}) values from the first disinfectant sequence to the last.
3. If SUM (CT_{calc}/CT_{99.9}) < 1, a treatment technique violation has occurred, and a "yes" response must be entered.

TABLE 6-5

DISTRIBUTION SYSTEM DISINFECTANT RESIDUAL DATA FOR UNFILTERED AND FILTERED SYSTEMS
MONTHLY REPORT TO PRMACY AGENCY

Month _____
Year _____

System/Treatment Plant _____
PWSID _____

Date	No. of Sites Where Disinfectant Residual was Measured (=a)	No. of Sites Where no Disinfectant Residual Measured, but HPC Measured (=b)	No. of Sites Where Disinfectant Residual Not Detected, no HPC Measured (=c)	No. of Sites Where Disinfectant Residual Not Detected, HPC > 500/ml (=d)	No. of Sites Where Disinfectant Residual Not Measured, HPC > 500 ml (=e)
1					
2					
3					
4					
5					
6					
7					
8					
9					
10					
11					
12					
13					
14					
15					
16					
17					
18					
19					
20					
21					
22					
23					
24					
25					
26					
27					
28					
29					
30					
31					
Total	a=	b=	c=	d=	e=

$$V = (c+d+e)/(a+b) \times 100 = (\underline{\quad} + \underline{\quad} + \underline{\quad}) / (\underline{\quad} + \underline{\quad}) \times 100 = \underline{\quad} \%$$

Prepared by _____
Date _____

TABLE 6-6

MONTHLY REPORT TO PRIMACY AGENCY FOR COMPLIANCE DETERMINATION - UNFILTERED SYSTEMS

Month _____ System/Treatment Plant _____
 Year _____ PWSID _____

Source Water Quality Conditions

- A. Cumulative number of months for which results are reported
 For source water coliform monitoring _____ (No. of months)
 For turbidity monitoring _____ (No. of months)

B. Coliform Criteria

	No. of Samples		No. of Samples Meeting Specified Limits	
	Fecal	Total	Fecal (<= 20/100 mL)	Total (<= 100/100mL)
Previous 6 months':	w = _____	x = _____	y = _____	z = _____
Percentage of samples <= 20/100 mL fecal coliforms, F = y/w x 100 = _____ %				
Percentage of samples <= 100/100 mL total coliforms, T = z/x x 100 = _____ %				
Is F < 90%?: Yes: _____ No: _____ N/A: _____; is T < 90%?: Yes: _____ No: _____ N/A: _____				

C. Turbidity Criteria

Maximum turbidity level for reporting (current) month = _____ NTU
 Enter the month 120 months prior to the reporting month or January 1991 (whichever is later) _____

Dates of 5 NTU Exceedances Since Latest Month Recorded Above		
Beginning Date	Duration (days)	Date Reported

Disinfection Criteria

A. Point-of-Entry Minimum Disinfectant Residual Criteria

Days the Residual was <0.2 mg/L		
Day	Duration of Low Level (hrs.)	Date Reported to Primacy Agency

B. Distribution System Disinfectant Residual Criteria

The value of a, b, c, d, and e from Table 6-5, as specified in 40 CFR 141.75 (b)(2)(iii)(A)-(E):

a = _____, b = _____, c = _____, d = _____, e = _____

$$V = \frac{c + d + e}{a + b} \times 100 = \text{_____ \%}$$

For previous month, V = _____ %

C. Disinfection Requirement Criteria

Record the date and value of SUM (CTcalc/CT99.9) for any SUM (CTcalc/CT99.9) < 1 (from Table 6-4):

If none, enter "none".

Date	SUM (CTcalc/CT99.9)

Prepared by _____
 Date _____

Notes:

- The current 6-month cumulatives are required to determine whether compliance with the coliform criteria has been achieved. These totals are calculated from: the previous 6-month cumulatives, the current month's, and totals from the earliest of 6 previous months.

TABLE 6-7

DAILY DATA SHEET FOR FILTERED SYSTEMS

(For system use only)

Month _____

System/Treatment Plant _____

Year _____

Filtration Technology _____

PWSID _____

Date	1	2				3	4	5
	Minimum Disinfectant Residual at Point-of-Entry to Distribution System (mg/L)	Filter #	Combined Filter Effluent	Clearwell Effluent	Plant Effluent	No. of Turbidity Measurements	No. of Turbidity Measurements ≤ Specified Limit	No. of Turbidity Measurements > 5 NTU
1								
2								
3								
4								
5								
6								
7								
8								
9								
10								
11								
12								
13								
14								
15								
16								
17								
18								
19								
20								
21								
22								
23								
24								
25								
26								
27								
28								
29								
30								
31								
Totals:								

Notes:

1. For multiple disinfectants, this column must only be completed for the last disinfectant added prior to entering the distribution system. If less than 0.2 mg/L, the duration of the period must be reported, e.g., "0.1-3 hrs".
2. For systems using conventional treatment, direct filtration, or technologies other than slow sand or diatomaceous earth filtration, turbidity measurements may be taken at the combined filter effluent, clearwell effluent, or plant effluent prior to entry into the distribution system. The turbidity may also be measured for each individual filter with a separate sheet maintained for each.
3. For continuous monitors count each 4-hour period as 1 sample.
4. Depending on the filtration technology employed, the number of turbidity samples meeting the following levels must be recorded: conventional treatment or direct filtration-0.5 NTU, slow sand filtration-1 NTU, diatomaceous earth filtration-1 NTU. The State may specify alternate performance levels for conventional treatment or direct filtration, not exceeding 1 NTU, and slow sand filtration, not exceeding 5 NTU, in which case the number of turbidity measurements meeting these levels must be recorded.
5. In recording the number of turbidity measurements exceeding 5 NTU, the turbidity values should also be recorded. e.g., 6.2, 8.0

TABLE 6-8

MONTHLY REPORT TO PRIMACY AGENCY FOR
COMPLIANCE DETERMINATION - FILTERED SYSTEMS

Month _____
Year _____

System/Treatment Plant _____
Type of Filtration _____
Turbidity Limit _____
PWSID _____

Turbidity Performance Criteria

- A. Total number of filtered water turbidity measurements = _____
- B. Total number of filtered water turbidity measurements that are less than or equal to the specified limits for the filtration technology employed = _____
- C. The percentage of turbidity measurements meeting the specified limits = $B/A \times 100 = \frac{\quad}{\quad} \times 100 = \quad\%$
- D. Record the date and turbidity value for any measurements exceeding 5 NTU: If none, enter "none".

Date	Turbidity, NTU

Disinfection Performance Criteria

- A. Point-of-Entry Minimum Disinfectant Residual Criteria

Date	Minimum Disinfectant Residual at Point-of-Entry to Distribution System (mg/L)	Date	Minimum Disinfectant Residual at Point-of-Entry to Distribution System (mg/L)	Date	Minimum Disinfectant Residual at Point-of-Entry to Distribution System (mg/L)
1		11		21	
2		12		22	
3		13		23	
4		14		24	
5		15		25	
6		16		26	
7		17		27	
8		18		28	
9		19		29	
10		20		30	
				31	

Days the Residual was <0.2 mg/L		
Day	Duration of Low Level (hrs.)	Date Reported to Primacy Agency

- B. Distribution System Disinfectant Residual Criteria

The value of a, b, c, d, and e from Table 6-5, as specified in 40 CFR 141.75 (b)(2)(iii)(a)-(e):

a = _____, b = _____, c = _____, d = _____, e = _____

$V = \frac{c + d + e}{a + b} \times 100 = \quad\%$

For previous month, V = _____ %

Prepared by _____
Date _____

7. COMPLIANCE

7.1 Introduction

This section provides guidance on when and how the requirements of the SWTR will go into effect, including determinations made by Primacy Agencies.

7.2 SYSTEMS USING A SURFACE WATER SOURCE (NOT GROUND WATER UNDER THE DIRECT INFLUENCE OF SURFACE WATER)

The SDWA requires, within 18 months following the promulgation of a rule, that Primacy Agencies promulgate any regulations necessary to implement that rule. Under S1413, these rules must be at least as stringent as those required by EPA. Thus, Primacy Agencies must promulgate regulations which are at least as stringent as the SWTR by December 30, 1990. By December 30, 1991, each Primacy Agency must determine which systems will be required to filter. If filtration is required, it must be installed within 18 months following the determination or by June 29, 1993, whichever is later. In cases where it is not feasible for a system to install filtration in this time period, the Primacy Agency may allow an exemption to extend the time period (see Section 9).

If a Primacy Agency fails to comply with this schedule for adopting the criteria and applying them to determine who must filter, systems must comply with the "objective" or self-implementing criteria (i.e., the requirements that are clear on the face of the rule and do not require the exercise of Primacy Agency discretion). Unfiltered supplies must comply beginning December 30, 1991 and filtered supplies beginning June 29, 1993.

Monitoring requirements for unfiltered systems must be met beginning December 30, 1990 unless the Primacy Agency has already determined that filtration is necessary. This coincides with the Agency's requirement to promulgate regulations for making filtration decisions by that date under the SDWA. Primacy Agencies may specify which systems should conduct the monitoring necessary to demonstrate compliance with the criteria for avoiding filtration. For some systems where an historical data base exists, and where it is apparent that the system would exceed the source

water quality criteria (or that some other criteria would not be met, such as an adequate watershed control program), no monitoring may be necessary for the Primacy Agency to determine that filtration is required. If a particular system (and/or the Primacy Agency) knows that it cannot meet the criteria for avoiding filtration, there is no reason to require that system to conduct the source water monitoring prior to the formal decision by the Primacy Agency that filtration is required. This is true because the only purpose of that monitoring would be to demonstrate whether or not the criteria to avoid filtration are being met.

In reviewing the data for determining which systems must filter, the Primacy Agency will have to decide on a case-by-case basis the conditions which will require filtration. For example, a system may not meet the specified CT requirements for the first few months of monitoring and upgrades its disinfection to meet the CT requirements in subsequent months. In this case, the Primacy Agency could conclude that the system will be able to meet this criterion for avoiding filtration. The time periods specified for in the criteria to avoid filtration (e.g., six months for total coliforms, one year and ten years for turbidity and one year for CT requirements) do not begin until December 30, 1991 unless the Primacy Agency specifies an earlier date.

Beginning December 30, 1991 the requirements for avoiding filtration specified in S141.71(a) and (b) and the requirements of S141.71(c) and S141.72(a) go into effect unless the Primacy Agency already has determined that filtration is required. Beginning December 30, 1991, if a system fails to meet any one of the criteria for avoiding filtration, even if the system were meeting all the criteria up to that point, it must install filtration and comply with the requirements for filtered systems including the general requirements in S141.73 and the disinfection requirements in S141.72(b), within 18 months of the failure. Whenever a Primacy Agency determines that filtration is required, it may specify interim requirements for the period prior to installation of filtration treatment.

Following the determination that filtration is required, the system must develop a plan to implement its installation. The plan must include consideration for the following:

- Providing uninterrupted water service throughout the transition period
- Siting for the future facility
- Financing options and opportunities
- Scheduling of design and construction

Systems which are unable to install filtration within the specified time frame may apply for an exemption to extend the period for installing filtration.

Table 7-1 summarizes the requirements for the SWTR for unfiltered systems noting conditions which require the installation of filtration. It is important to note that only treatment technique violations trigger the requirement to install filtration while violations of monitoring, reporting or analytical requirements do not. The monitoring requirements for unfiltered supplies are presented in Section 3 and the reporting requirements are presented in Section 6.

All systems with filtration in place must meet the treatment technique requirements specified in S141.73 (filtration criteria) and S141.72(b) (disinfection criteria), and the monitoring and reporting requirements specified in S141.74(c) and S141.75(b), respectively, beginning June 29, 1993. Table 7-2 summarizes the SWTR requirements for filtered systems, including conditions needed for compliance with treatment requirements. Monitoring requirements for filtered supplies are enumerated in Section 5 and reporting requirements are presented in Section 6.

7.3 Compliance Transition with Current NPDWR Turbidity Requirements

The current (interim) NPDWR for turbidity under S141.13 (MCL requirements) and S141.22 (monitoring requirements) will apply for unfiltered systems until December 30, 1991 unless the Primacy Agency determines that filtration is required. In cases where filtration is required, the interim NPDWR applies until June 29, 1993 or until filtration is installed, whichever is later. Unfiltered supplies will also be

subject to the turbidity monitoring requirements of S141.74(b)(2) beginning December 30, 1990 coincidentally with the interim requirements. Beginning June 29, 1993, the turbidity performance criteria for filtered systems (S141.73), and the monitoring requirements under S141.74 will apply.

**7.4 Systems Using a Ground Water Source
Under the Direct Influence of Surface Water**

Part of the Primacy Agency's program revisions to adopt the SWTR must include procedures for determining, for each system in the Primacy Agency served by a ground water source, whether that source is under the direct influence of surface water. By June 29, 1994 and June 29, 1999, each Primacy Agency must determine which community and non-community public water supplies, respectively, use ground water which is under the direct influence of surface water. EPA recommends that these determinations be made in conjunction with related activities required by other regulations (e.g., sanitary surveys pursuant to the final coliform rule, vulnerability assessments pursuant to the volatile organic chemicals rule, the forthcoming disinfection requirements for ground water systems). In addition, EPA-approved wellhead protection programs required under the Safe Drinking Water Act Section 1428 may contain methods and criteria for determining zones of contribution, assessments of potential contamination, and management of sources of contamination. These programs may be used as a partial basis for the vulnerability assessment and for making the determination of (a) whether a system is under the direct influence of surface water and (b) if direct influence is determined, whether there is adequate watershed control to avoid filtration. Guidelines for developing and implementing a wellhead protection program are found in "Guidelines for Applicants for State Wellhead Protection Program Assistance Funds under the Safe Drinking Water Act" (U.S. EPA, 1987a).

A system using a ground water source under the influence of surface water that does not have filtration in place must begin monitoring and reporting in accordance with S141.74(b) and S141.75(a), respectively, to determine whether it meets the criteria for avoiding filtration beginning December 30, 1990 or six months after the Primacy Agency determines that

TABLE 7-1

REQUIREMENTS FOR UNFILTERED SYSTEMS

Requirement	Criterion	Monitoring	Required for Compliance ⁽¹⁾	Triggers Filtration ⁽²⁾	Notification ⁽³⁾	
					Primary Agency	Public
Unfiltered Supplies (S141.71)						
a) Source Water Quality Conditions						
1) Fecal Coliform Total Coliform	20/100ml 100/100ml	Frequency based on population		<90% of samples from past 6 mos < criterion	monthly report	No
2) Turbidity	SNTU	continuous or grab/4 hrs	<SNTU	>SNTU unless "event"	next business day	Yes
b) Site-Specific Conditions						
1i) Disinfection for 3-log <i>Giardia</i> cyst & 4-log virus inactivation (S141.72(a))	CT _{99.9}	daily at peak flow except for one day per month	≥ criterion daily consecutive months (4)	violation for >1 of 12	monthly report	Yes
Redundant Disinfection Components (S141.72(a)(2))				components not in place	annual report of on-site inspection	Yes
Disinfectant Residual entering the system (S141.72(3)(1))	0.2 mg/l	continuous; systems <3300 population-grab samples	not <0.2 mg/l for >4 hours	violation if <0.2 mg/l for >4 hours unless Primacy Agency determines unusual and unpredictable	next business day if <0.2mg/l for any period of time	Yes (if <0.2 mg/L for >4 hours)
(ii) Disinfectant Residual in the Distribution System (S141.72(a)(4))	detectable residual or HPC ≤500/ml	(5) sample location & frequency based on population, approved by State	detectable in ≥ 95% of monthly samples for any two consecutive months	violation unless failure is not caused by deficiency in source water treatment	monthly report	Yes

TABLE 7-1

REQUIREMENTS FOR UNFILTERED SYSTEMS (Continued)

Requirement	Criterion	Monitoring	Required for Compliance ⁽¹⁾	Triggers Filtration ⁽²⁾	Notification	
					Primacy Agency	Public ⁽³⁾
2) Watershed Control Program	in place	activities in watershed		insufficient program as determined by Primacy Agency	annual report	
3) On-site inspection	annual	watershed program & disinfection system		insufficient program as determined by Primacy Agency	annual report	
4) Waterborne Disease Outbreak	no outbreaks recorded	public health	No outbreak with current configuration and source	outbreak with current configuration and source	next business day	Yes
5) Total Coliform Rule	≤1 positive for systems taking <40 samples/mo; ≤5.0% positive for systems taking ≥40 samples/mo.	frequency based on population	meet criterion each month	> criterion for >1 of 12 consecutive months unless failure is not caused by a deficiency in source water treatment	monthly report	
6) Total Trihalomethane Regulation	0.10 mg/l for systems serving >10,000	quarterly		> criterion based on annual average		

Notes:

1. Non-compliance results in a treatment technique violation.
2. Failure to install filtration within 18 months after failure to meet unfiltered supply criteria results in a treatment technique violation.
3. in local newspaper within 14 days of violation and mail notice with bill or by itself within 45 days of violation.
4. Violation may be allowed for 2 of 12 consecutive months if the Primacy Agency determines one violation to be caused by unusual and unpredictable circumstances.
5. Primacy Agency may determine whether adequate disinfection is provided.

TABLE 7-2

REQUIREMENTS FOR FILTERED SYSTEM

Requirement	Criterion	Monitoring	Compliance ⁽¹⁾	Notification	
				Primary Agency	Public ⁽²⁾
Filtered Supplies (SI41.73)					
a) Conventional or Direct Filtration	0.5 NTU (up to 1 NTU) ⁽⁴⁾	continuous or grab/4 hrs	95% monthly samples < MCL none > 5 NTU	monthly report	Yes
b) Slow sand Filtration	1 NTU (up to 5 NTU) ⁽⁴⁾	continuous or grab/4 hrs (one/day) ⁽⁴⁾	95% monthly samples < MCL none > 5 NTU	monthly report	Yes
c) Diatomaceous Earth Filtration	1 NTU	continuous or grab/4 hrs	95% monthly samples < 1 NTU none > 5 NTU	monthly report	Yes
d) Other Technologies	1 NTU up (to 5 NTU) ⁽⁴⁾	continuous or grab/4 hrs (one/day) ⁽⁴⁾	95% monthly samples < MCL none > 5 NTU	monthly report	Yes

TABLE 7-2

REQUIREMENTS FOR FILTERED SYSTEM (Continued)

Requirement	Criterion	Monitoring	Compliance ⁽¹⁾	Notification ⁽²⁾	
				Primacy Agency	Public
Disinfection for Filtered Supplies (S141.72(b))					
1) Supplement Filtration to meet Overall Treatment				as specified	Yes
2) Disinfectant Residual Entering System	0.2 mg/L	continuous; systems < 3300 population-grab samples	not < 0.2 mg/L for > 4 hrs	next business day	Yes
3) Disinfectant Residual in Distribution System	detectable residual or MPC ≤ 500 /ml ⁽³⁾	sample location & frequency based on population approved by State	not < MCL in > 5% of monthly samples for 2 consecutive months	monthly report	Yes

Notes:

1. Non-compliance results in a treatment technique violation.
2. In local newspaper within 14 days of violation and mail notice with bill or by itself within 45 days of violation.
3. Primacy Agency may determine whether adequate disinfection is provided.
4. If Primacy Agency exercises discretion.

the ground water source is under the influence of surface water, whichever is later. Within 18 months following the determination that a system is under the influence of surface water, the Primacy Agency must determine, using the same criteria that apply to systems using a surface water source, whether the system must provide filtration treatment. As for systems using a surface water source, the Primacy Agency must evaluate the data on a case-by-case basis to determine conditions which will trigger the need for filtration.

Beginning December 30, 1991 or 18 months after the determination that a system is under the direct influence of surface water, whichever is later, the criteria for avoiding filtration in S141.71(a) and (b) and the requirements for unfiltered systems in S141.71(c) and S141.72(a) go into effect, unless the Primacy Agency has determined that filtration is required. As with systems using a surface water source, subsequent failure to comply with any one of the criteria for avoiding filtration requires the installation of filtration treatment. Thus, beginning December 30, 1991 or 18 months after the Primacy Agency determines that a system is using a ground water source under the direct influence of surface water, whichever is later, a system which fails to meet any one of the criteria to avoid filtration must install filtration and comply with the requirements for filtered systems within 18 months of the failure or by June 29, 1993, whichever is later. As for unfiltered systems, systems under the direct influence of surface water may apply for an exemption to extend the time period for installing filtration.

Any system using a ground water source that the Primacy Agency determines is under the direct influence of surface water and that already has filtration in place at the time of the Primacy Agency determination must meet the treatment technique, monitoring and reporting requirements for filtered systems beginning June 29, 1993 or 18 months after the Primacy Agency determination, whichever is later.

7.5 Responses for Systems not Meeting SWTR Criteria

7.5.1 Introduction

Systems which presently fail to meet the SWTR criteria may be able to upgrade the system's design and/or operation and maintenance in order to achieve compliance. The purpose of this section is to present options which may be followed to achieve compliance.

7.5.2 Systems Not Filtering

Systems not filtering must meet the criteria to avoid filtration beginning December 30, 1991 and on a continuing basis thereafter or install filtration. Systems not filtering can be divided into two categories:

- A. Those systems not currently meeting the SWTR criteria but with the ability to upgrade to meet them.
- B. Those systems not able to meet the SWTR criteria by December 30, 1991. If the installation of filtration is not possible by June 29, 1993 the system may request an exemption and take interim measures to provide safe water to avoid violation of a treatment technique requirement.

Systems in Category A

Example A - Response Situation

Condition: System is not meeting the source water fecal and/or total coliform concentrations but has not received judgment on the adequacy of its watershed control.

Response Options:

- Monitor for fecal coliforms rather than total coliforms if this is not already done. Fecal coliforms are a direct indicator of fecal contamination where total coliforms are not. If total coliform levels are exceeded but fecal levels are not, the system meets the criteria.
- Take appropriate action in the watershed to assure fecal and total coliform concentrations are below the criteria, such as elimination of animal activity near the source water intake.

Example B - Response Situation

Condition: System meets the source water quality criteria, watershed control requirements, and is maintaining a disinfectant residual within the distribution system, but is not able to meet the CT requirements due to lack of contact time prior to the first customer.

Response Options:

- Increase the application of disinfectant while monitoring THM levels to ensure they remain below the MCL.
- Add additional contact time through storage to obtain an adequate CT.
- Apply a more effective disinfectant such as ozone.

Systems in Category B

Example A - Response Situation

Condition: System meets the source water turbidity but not the fecal coliform requirements. A sewage treatment plant discharges into the source water. A determination has been made that the system does not have adequate watershed control.

Response Options:

- Purchase water from a nearby surveyor or use an alternate source such as ground water if available.
- Take steps to install filtration, applying for an exemption (time delay) as presented in Section 9 where appropriate.

Example B

Condition: The source water exceeds a turbidity of 5 NTU for more than two periods in a year under normal weather and operating conditions.

Response Options:

- Purchase water from a nearby purveyor or use an alternate source such as ground water if available.
- Take steps to install filtration, applying for an exemption (time delay) as presented in Section 9 where appropriate.

In the interim prior to adoption of either of the above options, certain protective measures may be appropriate. One protective measure which can be used would be the issuance of a public notice to boil all water for consumption during periods when the turbidity exceeds 5 NTU. If such a notice is issued, the utility should continue sampling the distribution system for chlorine residual and total coliforms, and initiate measurement of HPCs in the distribution system. These data and the raw water turbidity should be used to determine when to lift the boil water notice.

The notice could be lifted when:

- The historical (prior to high turbidity) disinfectant residual concentration is reestablished in the distribution system;
- The total coliform requirements are met;
- The HPC count is less than 500/ml; and
- The turbidity of the raw water is less than 5 NTU.

7.4.3 Systems Currently Filtering

Systems which are currently filtering must meet the SWTR criteria within 48 months of the SWTR to be in compliance, after which the criteria must be continually met for the system to be in compliance.

Example A - Response Situation

Condition: A direct filtration plant is treating a surface water which is not compatible with this treatment process. The system is not achieving its required turbidity performance or disinfection criteria.

Response Options:

- Optimize coagulant dose.
- Reduce filter loading rates.
- Evaluate the effect on performance of installing flocculation and sedimentation ahead of the filters.

Example B - Response Situation

Condition: A filtration plant is using surface water which is compatible with its treatment system. The system is not achieving disinfection performance criteria required by the Primacy Agency to achieve a 1-log inactivation of Giardia cysts; however, it is meeting the requirements of the Total Coliform Rule.

Response Options:

- Increase disinfectant dosage(s).
- Install storage facilities to increase disinfectant contact time.
- Ensure optimum filtration efficiency by:
 - Use of a filter aid.
 - Reduction in filter loading rates.
 - More frequent backwashing of filters.

The Primacy Agency may grant additional removal credit for optimum filtration.

EPA intends to promulgate National Primary Drinking Water Regulations to regulate levels of disinfectants and disinfectant by-product when it promulgates disinfection requirements for ground water systems (anticipated in 1992). EPA is concerned that changes required in utilities' disinfection practices to meet the required inactivations for the SWTR might be inconsistent with treatment changes needed to comply with the forthcoming regulations for disinfectants and disinfection by-products. For this reason, the EPA is allowing Primacy Agencies discretion in determining the level of disinfection required for filtered systems to meet the overall treatment performance requirements specified in the rule or recommended based on source water quality.

During the interim period, prior to promulgation of the disinfection by-product regulation, EPA recommends that the Primacy Agency allow more credit for Giardia cyst and virus removal than generally recommended. This interim level is recommended in cases where the Primacy Agency determines that a system is not currently at a significant risk from microbiological concerns at the existing level of disinfection and that

a deferral is necessary for the system to upgrade its disinfection process to optimally achieve compliance with the SWTR as well as the forthcoming disinfection by-product regulations. Section 5.5.3 presents some guidelines for establishing interim disinfection requirements.

8. PUBLIC NOTIFICATION

The SWTR specifies that the public notification requirements of the Safe Drinking Water Act (SDWA) and the implementing regulations of 40 CFR Paragraph 141.32 must be followed. These regulations divide public notification requirements into two tiers. These tiers are defined as follows:

1. Tier 1:
 - a. Failure to comply with MCL
 - b. Failure to comply with prescribed treatment technique
 - c. Failure to comply with a variance or exemption schedule

2. Tier 2:
 - a. Failure to comply with monitoring requirements
 - b. Failure to comply with a testing procedure prescribed by a NPDWR
 - c. Operating under a variance/exemption. This is not considered a violation but public notification is required.

The SWTR classifies violations of Sections 141.70, 141.71(c), 141.72 and 141.73 (i.e., treatment technique requirements as specified in Section 141.76) as Tier 1 violations and violations of Section 141.74 as Tier 2 violations. Violations of 141.75 (reporting requirements) do not require public notification.

There are certain general requirements which all public notices must meet. All notices must provide a clear and readily understandable explanation of the violation, any potential adverse health effects, the population at risk, the steps the system is taking to correct the violation, the necessity of seeking alternate water supplies (if any) and any preventative measures the consumer should take. The notice must be conspicuous, not contain any unduly technical language, unduly small print or similar problems. The notice must include the telephone number of the owner or operator or designee of the public water system as a source of additional information concerning the violation where appropriate. The notice must be bi- or multilingual if appropriate.

In addition, the public notification rule requires that when providing information on potential adverse health effects in Tier 1 public

notices and in notices on the granting and continued existence of a variance or exemption, the owner or operator of a public water system must include certain mandatory health effects language. For violations of treatment technique requirements for filtration and disinfection, the mandatory health effects language is:

Microbiological Contaminants

The United States Environmental Protection Agency (EPA) sets drinking water standards and has determined that microbiological contaminants are a health concern at certain levels of exposure. If water is inadequately treated, microbiological contaminants in that water may cause disease. Disease symptoms may include diarrhea, cramps, nausea, and possibly jaundice and any associated headaches, and fatigue. These symptoms, however, are not just associated with disease-causing organisms in drinking water, but also may be caused by a number of factors other than your drinking water. EPA has set enforceable requirements for treating drinking water to reduce the risk of these adverse health effects. Treatment such as filtering and disinfecting the water removes or destroys microbiological contaminants. Drinking water which is treated to meet EPA requirements is associated with little to none of this risk and should be considered safe.

Further, the owner or operator of a community water system must give a copy of the most recent notice for any Tier 1 violations to all new billing units or hookups prior to or at the time service begins.

The medium for performing public notification and the time period in which notification must be sent varies with the type of violation and is specified in Section 141.32. For Tier 1 violations (i.e., violations of Sections 141.70, 141.71, 141.72 and 141.73), the owner or operator of a public water system must give notice:

1. By publication in a local daily newspaper as soon as possible but in no case later than 14 days after the violation or failure. If the area does not have a daily newspaper, then notice shall be given by publication in a weekly newspaper of general circulation in the area, and
2. By either direct mail delivery or hand delivery of the notice, either by itself or with the water bill not later than 45 days after the violation or failure. The Primacy Agency may waive this requirement if it determines that the owner or operator has corrected the violation within the 45 days.

Although the SWTR does not specify any acute violations, the Primacy Agency may specify some Tier 1 violations as posing an acute risk to human health; for example these violations may include:

1. A waterborne disease outbreak in an unfiltered supply.
2. Turbidity of the water prior to disinfection of an unfiltered supply or the turbidity of filtered water exceeds 5 NTU at any time.
3. Failure to maintain a disinfectant residual of at least 0.2 mg/l in the water being delivered to the distribution system.

For these violations or any others defined by the Primacy Agency as "acute" violations, the system must furnish a copy of the notice to the radio and television stations serving the area as soon as possible but in no case later than 72 hours after the violation. Depending upon circumstances particular to the system, as determined by the Primacy Agency, the notice may instruct that all water should be boiled prior to consumption.

Following the initial notice, the owner or operator must give notice at least once every three months by mail delivery (either by itself or with the water bill), or by hand delivery, for as long as the violation or failure exists.

There are two variations on these requirements. First, the owner or operator of a community water system in an area not served by a daily or weekly newspaper must give notice within 14 days after the violation by hand delivery or continuous posting of a notice of the violation. The notice must be in a conspicuous place in the area served by the system and must continue for as long as the violation exists. Notice by hand delivery must be repeated at least every three months for the duration of the violation.

Secondly, the owner or operator of a noncommunity water system (i.e., one serving a transitory population) may give notice by hand delivery or continuous posting of the notice in conspicuous places in the area served by the system. Notice must be given within 14 days after the violation. If notice is given by posting, then it must continue as long

as the violation exists. Notice given by hand delivery must be repeated at least every three months for as long as the violation exists.

For Tier 2 violations (i.e., violations of 40 CFR 141.74, analytical and monitoring requirements) notice must be given within three months after the violation by publication in a daily newspaper of general circulation, or if there is no daily newspaper, then in a weekly newspaper. In addition, the owner or operator shall give notice by mail (either by itself or with the water bill) or by hand delivery at least once every three months for as long as the violation exists. Notice of a variance or exemption must be given every three months from the date it is granted for as long as it remains in effect.

If the area is not served by a daily or weekly newspaper, the owner or operator of a community water system must give notice by continuous posting in conspicuous places in the area served by the system. This must continue as long as the violation does or the variance or exemption remains in effect. Notice by hand delivery must be repeated at least every three months for the duration of the violation or the variance of exemption.

For noncommunity water systems, the owner or operator may give notice by hand delivery or continuous posting in conspicuous places; beginning within 3 months of the violation or the variance or exemption. Posting must continue for the duration of the violation or variance or exemption and notice by hand delivery must be repeated at least every 3 months during this period.

The Primacy Agency may allow for owner or operator to provide less frequent notice for minor monitoring violations (as defined, by the Primacy Agency if EPA has approved the Primacy Agency's substitute requirements contained in a program revision application).

To provide further assistance in preparing public notices, several examples have been provided. However, each situation is different and may call for differences in the content and tone of the notice. All notices must comply with the general requirements specified above.

Example 1 - Tier 1 Violation-Unfiltered Supply

Following is an example of a Tier 1 violation which may be considered by the Primacy Agency to pose an acute risk to human health.

A system which does not apply filtration experiences a breakdown in the chlorine feed systems and the switchover system fails to activate the backup systems. A number of hours pass before the operator discovers the malfunction. The operator, upon discovery of the malfunction, contacts the local television and radio stations and announces that the public is receiving untreated water. The announcement may read as follows:

We have just received word from the Aswan Water Board that a malfunction of the disinfection system has allowed untreated water to pass into the distribution system. Thus, this system providing drinking water is in violation of a treatment technique requirement. The United States Environmental Protection Agency (EPA) sets drinking water standards and has determined that microbiological contaminants are a health concern at certain levels of exposure. If water is inadequately treated, microbiological contaminants in that water may cause disease. Disease symptoms may include diarrhea, cramps, nausea, and possibly jaundice and any associated headaches, and fatigue. These symptoms, however, are not just associated with disease-causing organisms in drinking water, but also may be caused by a number of factors other than your drinking water. EPA has set enforceable requirements for treating drinking water to reduce the risk of these adverse health effects. Treatment such as filtering and disinfecting the water removes or destroys microbiological contaminants. Drinking water which is treated to meet EPA requirements is associated with little to none of this risk and should be considered safe.

The temporary breakdown in disinfection may have allowed micro-organisms to pass into the distribution system. The operation of the system has been restored so that no further contamination of the distribution system will occur. Any further changes will be announced.

Additional information is available at the following number:
235-WATER.

A direct mailing of the notice is provided within 45 days of the occurrence.

Example 2 - Tier 1 Violation-Unfiltered Supply

Following is an example of a Tier 1 violation which may be considered by the Primacy Agency to pose an acute risk to human health.

A system supplies an unfiltered surface water to its customers. During a period of unusually heavy rains caused by a hurricane in the area, the turbidity of the water exceeds 5 NTU. The turbidity data during which the heavy rains occur is as follows:

<u>Day 1 NTU</u>	<u>Day 2 NTU</u>	<u>Day 3 NTU</u>	<u>Day 4 NTU</u>	<u>Day 5 NTU</u>
0.4	0.8	0.7	0.7	7.6
0.4	0.5	0.4	7.6	3.1
0.5	0.5	0.4	11.3	2.7
0.7	0.4	0.5	9.6	0.7
1.1	0.4	0.4	7.2	0.8
0.9	0.6	0.6	5.0	0.5

The following public notice was prepared and submitted to the local newspaper, television and radio stations within 72 hours of the first turbidity exceedence of 5 NTU.

The occurrence of heavy rains in our watershed is causing a rise in the turbidity of the drinking water supplied by Fairfax Water Company.

Turbidity is a measurement of particulate matter in water. It is of significance in drinking water because irregularly shaped particles can both harbor microorganisms and interfere directly with disinfection which destroys microorganisms. While the particles causing the turbidity may not be harmful or even visible at the concentrations measured, the net effect of a turbid water is to increase the survival rate of microorganisms contained in the water. This is of concern because several diseases are associated with waterborne microorganisms.

Because of the high turbidity levels, the Fairfax system is in violation of a treatment requirement set by the Environmental Protection Agency (EPA).

The United States Environmental Protection Agency (EPA) sets drinking water standards and has determined that microbiological contaminants are a health concern at certain levels of exposure. If water is inadequately treated, microbiological contaminants in that water may cause disease. Disease symptoms may include diarrhea, cramps, nausea, and possibly jaundice and any associated headaches, and fatigue. These symptoms, however, are not just associated with disease-causing organisms in drinking water, but also may be caused by a number of factors other than your drinking water. EPA has set enforceable requirements for treating drinking water to reduce the risk of these adverse health effects. Treatment such as filtering and disinfecting the water removes or destroys microbiological contaminants. Drinking water which is treated to

meet EPA requirements is associated with little to none of this risk and should be considered safe.

In order to protect yourself from illness, all water from the Fairfax system used for drinking, cooking and washing dishes should be boiled at a rolling boil for one minute.

The system is being closely monitored and a notice will be issued when the water returns to an acceptable quality and no longer needs to be boiled.

The utility continues sampling the distribution system for chlorine residual and total coliforms, and initiates measurement of the HPCs in the distribution system. The notice is lifted when all the following are met:

- The historical (prior to high turbidity) disinfectant residual concentration is reestablished in the distribution system.
- The total coliform requirements are met.
- The HPC count is <500/ml.
- The turbidity of the raw water is less than 5 NTU.

The Primacy Agency must decide whether the turbidity event was unusual or unpredictable and whether filtration should be installed.

Example 3 - Tier 1 Violation - Filtered Supply

A conventional treatment plant is treating a surface water. A malfunctioning alum feed system resulted in an increase of the filter effluent turbidities. The effluent turbidity was between 0.5 and 1.0 NTU in 20 percent of the samples for the month. The utility issued a notice which was published in a local daily newspaper within 14 days after the violation. The notice read as follows:

During the previous month, the Baltic Water Treatment Plant experienced difficulties with the chemical feed system. The malfunctions caused an effluent turbidity level above 0.5 NTU in 20 percent of the samples for the month. The current treatment standards require that the turbidity must be less than 0.5 NTU in 95 percent of the monthly samples. The Baltic drinking water system has thus been in violation of a treatment technique requirement.

The United States Environmental Protection Agency (EPA) sets drinking water standards and has determined that microbiological

contaminants are a health concern at certain levels of exposure. If water is inadequately treated, microbiological contaminants in that water may cause disease. Disease symptoms may include diarrhea, cramps, nausea, and possibly jaundice and any associated headaches, and fatigue. These symptoms, however, are not just associated with disease-causing organisms in drinking water, but also may be caused by a number of factors other than your drinking water. EPA has set enforceable requirements for treating drinking water to reduce the risk of these adverse health effects. Treatment such as filtering and disinfecting the water removes or destroys microbiological contaminants. Drinking water which is treated to meet EPA requirements is associated with little to none of this risk and should be considered safe.

The chemical, feed and switchover components of the system have been repaired and are in working order and turbidity levels are meeting the standard. It is unlikely that illness will result from the turbidity exceedences previously mentioned because continuous stringent disinfection conditions were in effect and the system was in compliance with other microbiological drinking water standards pertaining to microbiological contamination. However, a doctor should be contacted in the event of illness. For additional information call, 1-800-726-WATER.

9. EXEMPTIONS

9.1 Overview of Requirements

Section 1416 of the Safe Drinking Water Act allows a Primacy Agency to exempt any public water system within its jurisdiction from any treatment technique requirement imposed by a national primary drinking water regulation upon a finding that:

1. Due to compelling factors (which may include economic factors), the public water system is unable to comply with the treatment technique requirement;
2. The public water system was in operation on the effective date of the treatment technique requirement or, for a system that was not in operation by that date, only if no reasonable alternative source of drinking water is available to the new system; and
3. The granting of the exemption will not result in an unreasonable risk to health.

If a Primacy Agency grants a public water system an exemption, the Agency must prescribe, at the time the exemption is granted, a schedule for:

1. Compliance (including increments of progress) by the public water system with each treatment technique requirement with respect to which the exemption was granted; and
2. Implementation by the system of such control measures as the Primacy Agency may require during the period the exemption is in effect.

Before prescribing a schedule, the Primacy Agency must provide notice and opportunity for a public hearing on the schedule. The schedule prescribed must require compliance by the public water system with the treatment technique requirement as expeditiously as practicable, but in no case later than one year after the exemption is issued (except that, if the system meets certain requirements, the final date for compliance may be extended for a period not to exceed three years from the date the exemption is granted). For systems serving less than 500 service

connections, and meeting certain additional requirements, the Primary Agency may renew the exemption for one or more additional two-year periods.

Under the SWTR, no exemptions are allowed from the requirement to provide disinfection for surface water systems, but exemptions are available to reduce the degree of disinfection required. Exemptions from the filtration requirements are available. The following sections present guidelines for evaluating conditions under which exemptions are appropriate.

9.2 Recommended Criteria

In order to obtain an exemption from the SWTR, a system must meet certain minimum criteria to assure no unreasonable risk to health. These should be applied before looking at other factors such as economics. Recommended minimum criteria for assuring no unreasonable risk to health exists are listed below.

Systems which do not provide filtration

- Practice disinfection to achieve at least a 2-log inactivation of Giardia cysts; or comply with the disinfection requirements for the distribution system as defined in Section 141.72(b) of the SWTR.
- Comply with the monthly coliform MCL; or provide bottled water (or another alternate water source) or point of use treatment devices for their customers in which representative samples comply with all the MCL National Primary Drinking Water Regulations.

EPA recommends that in order to obtain an extension to the initial 1 year exemption period in addition to the required elements in Section 1416, the system would need to be in compliance with the monthly coliform MCL, satisfy the above disinfection criteria and not have any evidence of waterborne disease outbreaks attributable to the system at the end of that first exemption period. If at any point during the extended exemption period the system did not meet these conditions, the exemption should be withdrawn and the system should be subject to an enforcement action.

Systems which provide filtration

- Practice disinfection to achieve at least a 0.5 log inactivation of Giardia cysts; or comply with the disinfection requirements for the distribution system as defined in Section 141.72 of the rule.
- Comply with the monthly coliform MCL; or provide bottled water (or another alternate water source) or point of use treatment devices for their customers in which representative samples comply with all the MCL National Primary Drinking Water Regulations.
- Take all practical steps to improve the performance of its filtration system.

In order to obtain an extension to the initial exemption period, in addition to the required elements in Section 1416, the system should be in compliance with the coliform MCL, satisfy the above disinfection criteria and not have any evidence of waterborne disease outbreaks attributable to the treatment system at the end of that first exemption period. If at any point during the extended exemption period the system did not meet these conditions, the exemption should be withdrawn and the system should be subject to an enforcement action. In addition, the system must continue to be taking steps to improve the performance of its filtration system to achieve the criteria specified in the SWTR.

Once these minimum requirements are applied, the Primacy Agency should look at the other factors as described in Sections 9.3, 9.4, and 9.5.

9.3 Compelling Factors

Compelling factors are often associated with small systems. The major compelling factor tends to be economic. In some cases the compelling factor may not be solely economic, but rather the contractual and physical infeasibility of having a required treatment installed within the time period specified in the regulation. For example, it may not be feasible for a very large system to install filtration by June 1993 if required. In such cases exemptions are also appropriate. Additional considerations for small systems are presented in Appendix L.

If system improvements necessary to comply with the SWTR incur costs which the Primacy Agency determines pose an economic barrier to acquisition of necessary treatment, the system fulfills the criteria of demonstrating a compelling hardship which makes it unable to meet the treatment requirements. In such cases, the EPA believes it is reasonable to grant an exemption if the system also meets the criteria in 9.4 and 9.5.

The USEPA document, "Technologies and Costs for the Removal of Microbial Contaminants from Potable Water Supplies," contains costs associated with available treatment alternatives (USEPA, 1988b). Costs found in this document, or those generated from more site-specific conditions, can be used as the basis for determining the ability of a system to afford treatment. The total annual water production costs per household for a system can be estimated based on the household water usage and the production costs per thousand gallons. As estimated in the above cited USEPA document, each cent per thousand gallons of treated water is approximately equivalent to \$1 per year per household if a household water usage of 100,000 gallons per year is assumed.¹ This estimate will need to be adjusted according to water usage for cases where the household usage differs from 100,000 gallons per year.

The following examples are presented to provide guidance in estimating costs for a system to upgrade its system or install filtration. This cost information could be used for determining whether a system might be eligible for an exemption.

Example 1

A water system which supplies an average daily flow of 0.05 mgd to a small urban community receives its water supply from a lake. The system currently provides disinfection with chlorine but does not provide filtration. The system reviewed its source water quality and found the characteristics to be as follows:

¹ This is the national average residential household consumption reported in: Final Descriptive Summary - 1986 Survey of Community Water Systems. October 23, 1987. USEPA: Office of Drinking Water.

Total coliforms	1,000/100 ml
Turbidity	10 - 13 NTU
Color	6 - 9 CU

Based upon the criteria in the SWTR, this source requires filtration and a review of the water quality criteria presented in Table 4-2 indicates that the treatment technique best suited to these source conditions is conventional treatment. A conventional package treatment plant with a capacity of 0.068 MGD may be purchased and put on line at a cost of \$277/household-year not including real estate, piping or raw water pumping costs which may be significant depending on the plant location.² EPA has estimated that, on average, these costs might add another 50% depending on site specific factors (USEPA, 1989)

Thus the cost estimate for implementing filtration indicates that the increase in the average annual household water bill would be approximately \$277 plus the cost of real estate, piping, and raw water pumping as needed. The incomes of people in the community and the current water bills can be reviewed by the Primacy Agency along with these estimated costs to determine if an undue economic hardship is incurred by these treatment methods. Upon determination that an economic hardship is incurred, the Primacy Agency may grant an exemption from filtration, provided that the system can assure the protection of the health of the community. However, if the water supply system for a nearby community meets the drinking water standards and there is the ability to hook up to that system, an exemption generally should not be granted unless such costs also presented an economic hardship.

Example 2

A large urban community, with a median annual income of \$25,000 per family, is supplied with water from lakes and reservoirs. The community places an average daily demand of 3 mgd on the supply system. The watershed of the system is moderately populated and used for farming and

² Table VI-3 ("Technologies and Costs for the Removal of Microbial Contaminants From Potable Water Supplies," USEPA, 1988b) lists the total costs as 277.4 cents/1000 gal. Estimated costs for real estate, piping, and raw water pumping as a function of site specific conditions are available in Table E-1, E-2, and E-3 of this same document.

grazing. The system currently provides filtration using diatomaceous earth filtration and disinfection with chloramines.

A review of the source and finished water quality was conducted to evaluate the plant's performance. The source water quality was determined to be:

Total coliforms	30 - 40/100 ml
Turbidity	2 - 3 NTU
Color	1 - 2 CU

Diatomaceous earth is therefore an acceptable filtration method.³ However, review of the finished water showed that a residual in the distribution system is only maintained 80 percent of the time. In addition to this, coliforms were detected in 10 percent of the samples taken over the twelve month period. Inspection of the chlorination equipment showed the equipment is deteriorated. Review of the monthly reports showed that the coliforms appeared in the distribution system shortly after the chlorinators malfunctioned. This observation led to the conclusion that new disinfection facilities were needed.

The source water quality and available contact time after disinfection were then used to determine the most appropriate disinfectant for the system. As described in Section 5.5, ozone, chlorine or chlorine dioxide can be used as primary disinfectants given these conditions. A preliminary review of costs for applying the various disinfectants showed chlorine to be the most economical at a cost of \$2.8/household/year⁴ (USEPA, 1988b). This cost does not include backup equipment; however, even with providing duplicate equipment doubling this cost to \$5.6/household/year, the improvement incurs minimal cost and the Primacy Agency should not grant the system an exemption based on economic hardship.

³ As determined from Table 4-2 of Section 4.

⁴ Table VI-12 (USEPA, 1988b) lists a total cost of 2.8 cents/1000 gal for a plant capacity of 5.85 mgd.

$$\frac{(2.8 \text{ cents})}{(1,000 \text{ gal})} \frac{(\$1/\text{household-year})}{(\text{cents}/1000 \text{ gal})} = \$2.8/\text{household-year}$$

9.4 Evaluation of Alternate Water Supply Sources

Systems which would incur very high costs for installing a required treatment to comply with the SWTR, should evaluate the possibility of using an alternate source. These alternate sources include:

- The use of ground water
- Connection to a nearby water purveyor
- Use of an alternate surface water supply

When considering the use of ground water, the purveyor must determine the capacity of the underlying aquifer for supplying the demand. The water quality characteristics of the aquifer must be evaluated to determine what treatment may be needed to meet existing standards. The cost of the well construction and treatment facilities must then be determined and converted into a yearly cost per household.

The connection to a nearby purveyor involves contacting the purveyor to determine their capacity and willingness to supply the water. Once it has been determined that the alternate source meets all applicable drinking water standards, the cost of the transmission lines, distribution system, and other facilities (e.g. disinfection, repumping, etc.) must then be determined and amortized into a yearly cost per household.

If the cost for using an alternate source is found by the Primacy Agency to present an economic hardship, and the purveyor can demonstrate that there will be no unreasonable risk to health, the Primacy Agency may grant an exemption to the SWTR for the purveyor and develop a schedule of compliance.

9.5 Protection of Public Health

Systems which apply for an exemption from the SWTR must demonstrate to the Primacy Agency that the health of the community will not be put at risk by the granting of such an exemption. A system should be able to provide adequate protection for the public health by meeting the minimum suggested EPA requirements in Section 9.2. However, a Primacy Agency may specify additional measures or criteria a system must meet to protect public health, depending on the particular circumstances. Systems with currently unfiltered surface water supplies which fail to meet the source

water quality criteria will be required to install filtration as part of their treatment process. However, it may take 3 to 5 years or more before the filtration system can be designed, constructed and begin operation, thereby justifying the granting of an exemption. During this period, possible interim measures which the system could take to further satisfy the Primacy Agency's concern include one or more of the following:

- a. Use of higher disinfectant dosages without exceeding the TTHM MCL (even for systems not currently subject to this MCL)
- b. Installation of a replacement or additional disinfection system which provides greater disinfection efficiency and which can be integrated into the new filtration plant
- c. Increasing the monitoring and reporting to the Primacy Agency
- d. Increasing protection of the watershed
- e. Increasing the frequency of sanitary surveys
- f. Temporarily purchasing water from a nearby water system
- g. For small systems, temporary installation of a mobile filtration (package) plant
- h. Increasing contact time by rerouting water through reservoirs

In some cases systems may be able to increase their disinfection dosages during the interim period to provide additional protection against pathogenic organisms. This alternative should be coupled with a requirement for increased monitoring for coliforms, HPC and disinfectant residual within the distribution system. However, disinfectant dosage should not be increased if this would result in a violation of the TTHM MCL, even for systems not currently subject to this MCL.

Systems which are planning to install filtration may be able to utilize a more efficient disinfectant that can later be integrated into the filter plant. Currently ozone and chlorine dioxide are considered to be the most efficient disinfectants.

For all systems which do not meet the source water quality criteria and must install filtration, EPA recommends that during the interim period the Primacy Agency increase its surveillance of the system and require

increased monitoring and reporting requirements to assure adequate protection of the public health.

Any required increases in watershed control and/or on-site inspections will not alleviate the need for more stringent disinfection requirements and increased monitoring of the effectiveness of the system employed. Their purpose would be to identify and control all sources of contamination so that the existing system will provide water of the best possible quality.

For some systems, it may be possible to purchase water from a nearby system on a temporary basis. This may involve no more than the use of existing interconnections or it may require the installation of temporary connections.

Trailer mounted filtration units (package plants) are sometimes available from state agencies for emergencies or may be rented or leased from equipment manufacturers.

Systems may also be required to supply bottled water or install point-of-entry (POE) treatment devices. For the reasons listed below, these alternatives should only be utilized if the previously mentioned alternatives are not feasible:

- In many states bottled water is subject only to the water quality requirements of the FDA as a beverage and not to the requirements of the Safe Drinking Water Act.
- Point-of-entry treatment devices are not currently covered by performance or certification requirements which would assure their effectiveness or performance.

If the installation of POE devices is required, the selection of the appropriate treatment device should be based upon a laboratory or field scale evaluation of the devices. A guide for testing the effectiveness of POE units in the microbiological purification of contaminated water is provided in Appendix N.

Several issues arise with the use of POE devices. These include establishing who or what agency (1) has the responsibility for ensuring compliance with standards; (2) retains ownership of the treatment units; (3) performs monitoring, analyses and maintenance; and (4) manages the

treatment program and maintains insurance coverage for damage and liability. It should also be considered that there is no significant increase in risk over centrally treated water.

These issues should be borne in mind when POE as a treatment alternative is being considered.

Systems with currently unfiltered surface water supplies which meet the source water quality criteria, but do not meet one or more of the other requirements for watershed control, sanitary survey, compliance with annual coliform MCL or disinfection by-product regulation(s), will be required to install filtration unless the deficiencies can be corrected within 48 months of promulgation of the SWTR. Interim protection measures include those previously listed.

Systems with currently unfiltered surface water supplies which meet the source water quality criteria and the site specific criteria but which do not meet the disinfection requirements, will be required to install filtration unless the disinfection requirements (adequate CT and/or disinfection system redundancy) can be met. During the interim period, available options include:

- a. Temporary installation of a mobile treatment plant
- b. Temporary purchase of water from a nearby purveyor
- c. Increased monitoring of the system
- d. Installation of temporary storage facilities to increase the disinfectant contact time

Currently filtered supplies which fail to meet the turbidity or disinfection performance criteria presented in Section 5 will be required to evaluate and upgrade their treatment facilities in order to attain compliance. During the interim period available options for improving the finished water quality include:

- a. Use of a filter aid to improve filter effluent turbidities
- b. Increased disinfectant dosages
- c. The addition of an alternate disinfectant is an option after the disinfection by-products rule is promulgated

- d. Reduction in filter loading rates with subsequent reduction in plant capacity
- e. Installation of temporary storage facilities to increase disinfectant contact time

9.6 Notification to EPA

The SDWA requires that each Primacy Agency which grants an exemption notify EPA of the granting of this exemption. The notification must contain the reasons for the exemption, including the basis for the finding that the exemption will not result in an unreasonable risk to public health and document the need for the exemption.

REFERENCES

REFERENCES

Ali-Ani, M.; McElroy, J. M.; Hibler, C. P.; Hendricks, D. W. Filtration of Giardia Cysts and other Substances, Volume 3: Rapid Rate Filtration. EPA-600/2-85-027, U.S. Environmental Protection Agency, WERL, Cincinnati, Ohio, April, 1985.

American Public Health Association; American Water Works Association; Water Pollution Control Federation. Standard Methods for the Examination of Water and Wastewater, 16th ed., pp. 134-6, 298-310, 827-1038, 1985.

American Public Health Association; American Water Works Association; Water Pollution Control Federation. Standard Methods for the Examination of Water and Wastewater, 17th ed., 1989.

American Water Works Association. Manual of Water Supply Practices and Water Chlorination Principles and Practices, 1973.

American Water Works Association Research Foundation (AWWARF). A Summary of State Drinking Water Regulations and Plan Review Guidance. June, 1986.

Bader, H.; Hoigne, J. Determination of Ozone in Water by the Indigo Method, Water Research 15; 449-454, 1981.

Bellamy, W. D.; Lange, K. P.; Hendricks, D. W. Filtration of Giardia Cysts and Other Substances. Volume 1: Diatomaceous Earth Filtration. EPA-600/2-84-114, U.S. Environmental Protection Agency, Cincinnati, Ohio, 1984.

Bellamy, W. D.; Silverman, G. P.; Hendricks, D. W. Filtration of Giardia Cysts and Other Substances. Volume 2: Slow Sand Filtration. EPA-600/2-85-026, U.S. Environmental Protection Agency, MERL, Cincinnati, Ohio, April, 1985.

Bishop, S.; Craft, T. F.; Fisher, D. R.; Ghosh, M.; Prendiville, P.W.; Roberts, K. J.; Steimle, S.; Thompson, J. The Status of Direct Filtration, Committee Report. J.AWWA, 72(7):405-411, 1980.

Bouwer, H. Ground Water Hydrology. McGraw Hill Book Co., New York, pp. 339-356, 1978.

Brown, T. S.; Malina, J. F., Jr.; Moore, B. D. Virus Removal by Diatomaceous Earth Filtration - Part 1 & 2. J.AWWA 66(2):98-102, (12):735-738, 1974.

Bucklin, K.; Amirtharajah, A.; Cranston, K. Characteristics of Initial Effluent Quality and Its Implications for the Filter-to-Waste Procedure. AWWA Research Foundation Report. November, 1988.

Carlson, D.A.; Seabloom, R.W.; DeWalle, F.D.; Wetzler, T.F.; Evgeset, J.; Butler, R.; Wangsuthachart, S.; Wang, S. Ultraviolet Disinfection of Water for Small Water Systems. EPA/600/2-85-092, U.S. Environmental Protection Agency, Water Engineering Reserach Laboratory, Drinking Water Research Division, Cincinnati, Ohio, September, 1985.

Clark, R.M.; Regli, S. A Mathematical and Statistical Analysis for the Inactivation of Giardia lamblia by Free Chlorine. Submitted to the Journal of Environmental Science Engineering, 1989.

Clark, R.; Regli, S.; Black, D. Inactivation of Giardia lamblia by Free Chlorine: A Mathematical Model. Presented at AWWA Water Quality Technology Conference. St. Louis, Mo., November 1988.

Cleasby, J. L.; Hilmo, D. J.; Dimitracopoulos, C. J. Slow-Sand and Direct In-Line Filtration of a Surface Water. J.AWWA, 76(12):44-55, 1984.

DeWalle, F. B.; Engeset, J.; Lawrence, W. Removal of Giardia lamblia Cysts by Drinking Water Plants. EPA-600/S2-84-069, United States Environmental Protection Agency, MERL, Cincinnati, Ohio, May 1984.

Fox, K. R.; Miltner, R. J.; Logsdon, G. S.; Dicks, D. L.; Drolet, L. F. Pilot Plant Exploration of Slow Rate Filtration. Presented at the AWWA Annual Conference Seminar, Las Vegas, Nevada, June 1983.

Fujioka, R.; Kungskulniti, N.; Nakasone, S. Evaluation of the Presence - Absence Test for Coliforms and the Membrane Filtration Method for Heterotrophic Bacteria. AWWA Technology Conference Proceedings, November, 1986.

Geldreich, E. Personal communication to Linda Averell, Malcolm Pirnie Engineers, Paramus, New Jersey, July 1989.

Great Lakes-Upper Mississippi River Board of State Public Health and Environmental Managers Committee. Recommended Standards for Water Works, 1987 Edition.

Hendricks, D.; Al-Ani, M.; Bellamy, W.; Hibler, C.; McElroy, J. Surrogate Indicators for Assessing Removal of Giardia Cysts, AWWA Water Quality Technology Conference, 1984.

Hoff, J. C. Inactivation of Microbial Agents by Chemical Disinfectants. EPA-600/S2-86-067, U.S. Environmental Protection Agency, Water Engineering Research Laboratory, Drinking Water Research Division, Cincinnati, Ohio, September 1986.

Hoffbuhr, J. W.; Blair, J.; Bartleson, M.; Karlin, R. Use of Particulate Analysis for Source and Water Treatment Evaluation. AWWA Water Quality Technology Conference Proceedings, November 1986.

Horn, J. B.; Hendricks, D. W. Removals of Giardia Cysts and other Particles from Low Turbidity Waters Using the Culligan Multi-Tech Filtra-

tion System. Engineering Research Center, Colorado State University, Unpublished, 1986.

Joost, R. D.; Long, B. W.; Jackson, L. Using Ozone as a Primary Disinfectant for the Tucson CAP Water Treatment Plant, presented at the IOA/PAC Ozone Conference, Monroe, MI, 1988.

Kuchta, J. M.; States, S. J.; McNamara, A. M.; Wadowsky, R. M.; Yee, R. B. Susceptibility of Legionella pneumophila to Chlorine in Tap Water. Appl. Environ. Microbiol., 46(5): 1134-1139, 1983.

Letterman, R. D. The Filtration Requirement in the Safe Drinking Water Act Amendments of 1986. U.S. EPA/AAAS Report, August 1986.

Logsdon, G. S.; Symons, J. M.; Hoyer, Jr., R. L.; Arozarena, M. M. Alternative Filtration Methods for Removal of Giardia Cysts and Cyst Model. J.AWWA, 73:111-118, 1981.

Logsdon, G.; Thurman, V.; Frindt, E.; Stoecker, J. Evaluating Sedimentation and Various Filter Media for Removal of Giardia Cysts. J. AWWA, 77:2:61, 1985.

Logsdon, G. S. Report for Visit to Carrollton, Georgia, USEPA travel report, February 12, 1987a.

Logsdon, G. S. Comparison of Some Filtration Processes Appropriate for Giardia Cyst Removal. USEPA Drinking Water Research Division; Presented at Calgary Giardia Conference, Calgary; Alberta, Canada, February 23-25, 1987b.

Long, R. L. Evaluation of Cartridge Filters for the Removal of Giardia lamblia Cyst Models from Drinking Water Systems. J. Environ. Health, 45(5):220-225, 1983.

Markwell, D. D., and Shortridge, K. F. Possible Waterborne Transmission and Maintenance of Influenza Viruses in Domestic Ducks. Applied and Environmental Microbiology, Vol. 43, pp. 110-116, January, 1981.

Morand, J., M.; C. R. Cobb; R. M. Clark; Richard, G. S. Package Water Treatment Plants, Vol. 1, A performance Evaluation. EPA-600/2-80-008a, USEPA, MERL, Cincinnati, Ohio, July 1980.

Morand, J. M.; Young, M. J. Performance Characteristics of Package Water Treatment Plants, Project Summary. EPA-600/52-82-101, USEPA, MERL, Cincinnati, Ohio, March, 1983.

Muraca, P.; Stout, J. E.; Yu, V. L. Comparative Assessment of Chlorine, Heat, Ozone, and UV Light for Killing Legionella pneumophila Within a Model Plumbing System. Appl. Environ. Microbiol., 53(2):447-453, 1987.

Notestine, T., Hudson, J. Classification of Drinking Water Sources as Surface or Ground Waters. Final Project Report. Office of Environmental

Health Programs. Washington Department of Social and Health Services, August 1988.

Poynter, S. F. B.; Slade, J. S. The Removal of Viruses by Slow Sand Filtration, Prog. Wat. Tech. Vol. 9, pp. 75-88, Pergamon Press, 1977. Printed in Great Britain.

Randall, A.D. Movement of Bacteria From a River to a Municipal Well - A Case History. American Water Works Association Journal. Vol. 62, No. 11, p.716-720., November 1970.

Rice, E.W.; Hoff, J.C. Inactivation of Giardia lamblia cysts by Ultraviolet Radiation. Appl. Environ. Microbiol. 42: 546-547, 1981.

Robeck, G. G.; Clarke, N. A.; Dostal, K. A. Effectiveness of Water Treatment Processes in Virus Removal. J. AWWA, 54(10):1275-1290, 1962.

Robson, C.; Rice, R.; Fujikawa, E.; Farver, B. Status of U.S. Drinking Water Treatment Ozonation Systems, presented at IOA Conference, Myrtle Beach, SC, December 1988.

Rose, J. Cryptosporidium in Water; Risk of Protozoan Waterborne Transmission. Report prepared for the Office of Drinking Water, U.S. EPA, Summer, 1988.

Rubin, A. Factors Affecting the Inactivation of Giardia Cysts by Monochloramine and Comparison with other Disinfectants. Water Engineering Research Laboratory, Cincinnati, OH, March 1988a.

Rubin, A. "CT Products for the Inactivation of Giardia Cysts by Chlorine, Chloramine, Iodine, Ozone and Chlorine Dioxide" submitted for publication in J. AWWA, December 1988b.

Slezak, L.; Sims, R. The Application and Effectiveness of Slow Sand Filtration in the United States. J.AWWA, 76(12):38-43, 1984.

Sobsey, M. Detection and Chlorine Disinfection of Hepatitis A in Water. CR-813-024. EPA Quarterly Report. December 1988.

Stolarik, G.; Christie, D. Projection of Ozone C-T Values Los Angeles Aqueduct Filtration Plant, 1988.

U. S. Environmental Protection Agency, Office of Drinking Water, Criteria and Standards Division. Manual for Evaluating Public Drinking Water Supplies, 1971.

U. S. Environmental Protection Agency, Office of Drinking Water. Public Notification Handbook for Drinking Water Suppliers, May 1978.

U. S. Environmental Protection Agency, Office of Ground Water Protection. Guidelines for Applicants for State Wellhead Protection Program Assistance Funds Under the SDWA, June 1987a.

U. S. Environmental Protection Agency, Office of Ground Water Protection. Guidelines for Delineation of Wellhead Protection Area, June 1987b.

U. S. Environmental Protection Agency, Office of Drinking Water. Workshop on Emerging Technologies for Drinking Water Treatment, April, 1988a.

U. S. Environmental Protection Agency, Office of Drinking Water. Technologies and Costs for the Removal of Microbial Contaminants from Potable Water Supplies, October, 1988b.

World Health Organization Collaborating Center. Slow Sand Filtration of Community Water Supplies in Developing Countries. Report of an International Appraiser Meeting, Nagpur, India, Bulletin Series 16, September 15-19, 1980.

APPENDIX A
EPA CONSENSUS METHOD
FOR GIARDIA CYST ANALYSIS

TESTING FOR GIARDIA IN WATER

To begin the workgroups on testing, Jay Vasconcelos gave a slide presentation about the testing method used in the Region 10 Laboratory. The following pages and Appendix C summarize his talk.

Methods of Testing for Giardia in Water (George (Jay) Vasconcelos, Regional Microbiologist, Region 10 Laboratory, Manchester, Washington)

Background:

Although recent development of an excystation technique by Drs. Bingham, Meyer, Rice and Schaefer could in future lead to developing cultural methods, at this time no reliable methods exist for culturing Giardia cysts from water samples. At present, the only practical method for determining the presence of cysts in water is by direct microscopic examination of sample concentrates.

Microscopic detection in water-sample concentrates isn't an ideal process. Finding and identifying the cysts relies almost entirely on the training, skill, experience and persistence of the examiner. (And it is a skill not widespread among water-supply laboratories.) But despite its limitations, microscopic identification is currently the best method we have.

Years ago, the basic assumption was made that in order to find Giardia cysts in water, some form of sample concentration was necessary. As early as 1950, labs were using membrane filters with a porosity of 0.45 μm . With few exceptions, these attempts were unsuccessful. The center for Disease Control has tried particulate filtration, with diatomaceous earth as the medium. This removed the cysts from the water, but the cysts couldn't be separated from the particles of diatomaceous earth.

With the recent increase in the incidence of waterborne giardiasis, further efforts have been made to improve the detection method. An ideal method would be one that recovers all cysts in a water sample rapidly, cheaply and simply; allows rapid detection, identification and quantification; and provides information on the viability of and/or infectivity potential of cysts detected.

Unfortunately, no such method exists. The methods presently available can be broadly separated into two general stages: primary concentration and processing (see Table 1 on next page), and detection and identification (see Table 2 on next page).

TESTING FOR GIARDIA IN WATER

Methods of Testing for Giardia in Water (Continued...)

TABLE 1: PRIMARY CONCENTRATION AND PROCESSING METHODS

<u>METHOD</u>	<u>INVESTIGATOR (S)</u>	<u>RESULTS</u>
1. Membrane Filtration		
Cellulosic (47mm-0.45um)	Chang & Kabler USPHS, 1956	Generally unsuccessful
Polycarbonate (293mm-5um)	Pyper, DuFrain & Henry Eng 1982, (unpublished)	Passing 1 gal/min @ 10 PSI. 15-1800 gal total.
2. Particulate Filtration (diatomaceous earth, sand, etc.)		
	Shaw et al, 1977 Juranez, 1979	Generally good removal but poor elution
3. Algae (Forst) Centrifuge		
	Holman et al, 1983 DMHS, Washington	Good rapid recovery, but limited in field use.
4. Anionic and Cationic Exchange Resins		
	Brewer, Wright State UN. (unpublished)	Generally unsuccessful
5. Epoxy-Fiberglass Balston Tube Filters (10"-8um)		
	Riggs, CDHS Lab, Berkley, CA (unpublished)	Overall recovery 20-80%
6. Microporous Yarnwoven Depth Filters (7 & 1um orlon & polypropylene)		
	Jakubowski, Erickson, 1979 & 1980, EPA-Cincinnati	Recovery 3-15% Extraction ave. 58%
7. Pellican Cassette System		
	Millipore Corp. (unpublished)	May be useful for processing filter washings
8. Filterwashing Apparatus		
	DuWalle, U. of Wash., 1982 (unpublished)	Claims 75% recovery from orlon filters

TABLE 2: DETECTION METHODS

<u>METHOD</u>	<u>INVESTIGATORS(S)</u>	<u>RESULTS</u>
1. Immunofluorescen		
DFA	Riggs, CSDHS Lab, Berkley, CA 1983	Good prep., Cross Rx
IFA	Sauch, EPA-Cincinnati Riggs, CSOS	Still under study
<u>Monoclonal Antibodies</u>	Riggs, CSDHS Sauch, EPA-Cincinnati (unpublished)	Still under study
2. ELISA Method		
	Hungar, J. Hopkins MD, 1983	Feces samples only
3. Brightfield/Phase Contrast		
	EPA Consensus method	Ongoing

TESTING FOR GIARDIA IN WATER

Methods of Testing for Giardia in Water (Continued...)

Copies of Table 1 and Table 2 are also shown in Appendix C, along with further detail about the methods.

EPA Consensus Method:

In September, 1980, the EPA convened a workshop on Giardia methodology in Cincinnati. Its main purpose was to identify the best available methodology, and to agree on a reference method. The five labs in attendance recognized that any proposed method would be based in large part on opinions and personal preferences rather than on hard data, but that agreeing on a consensus method would promote uniformity and provide a basis for future comparisons. Our lab has modified the EPA consensus method slightly for our use. This method is outlined below.

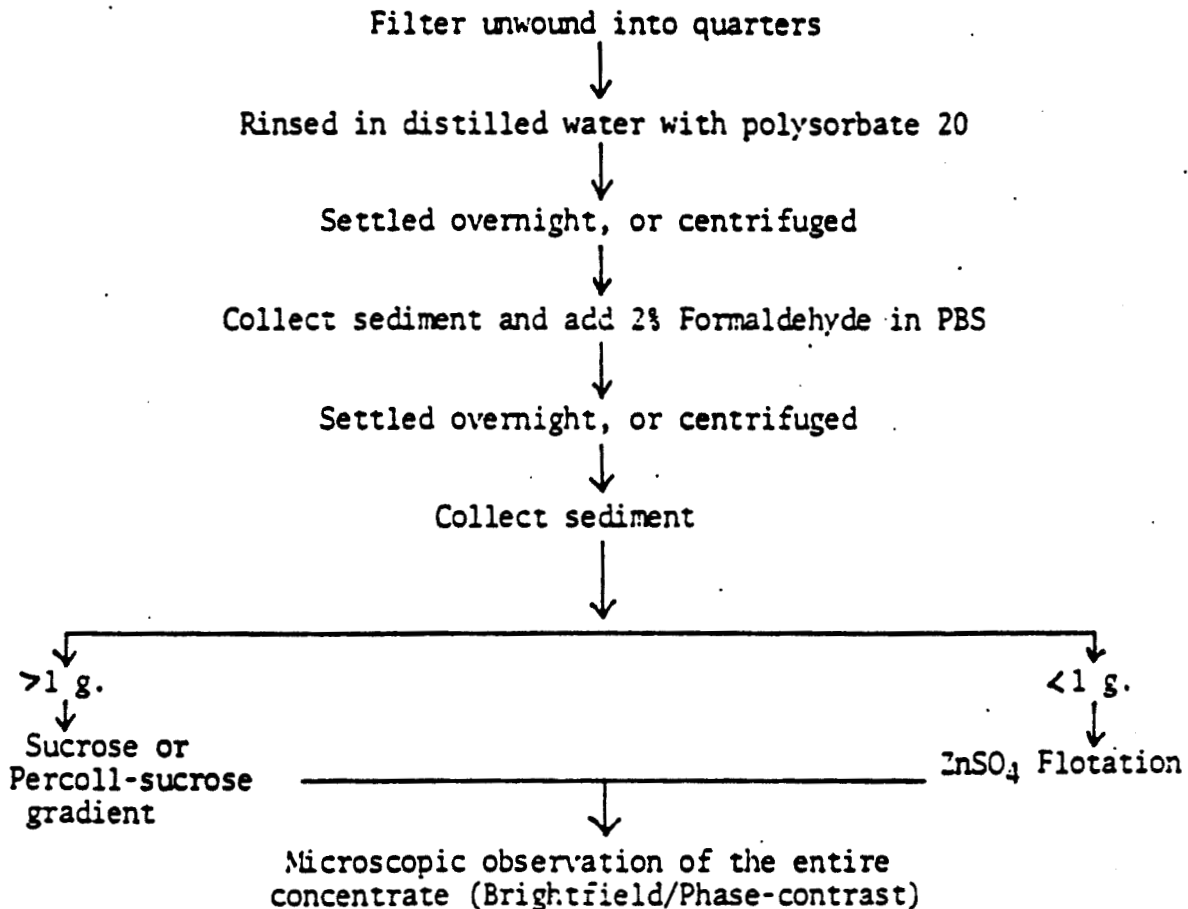

APPENDIX B
INSTITUTIONAL CONTROL OF LEGIONELLA

APPENDIX B
INSTITUTIONAL CONTROL OF LEGIONELLA

Legionella is a genus name for bacteria commonly found in lake and river waters. Some species of this genus have been identified as the cause of the disease legionellosis. In particular, Legionella pneumophila has been identified as the cause of Legionnaires disease, the pneumonia form of legionellosis and with Pontiac Fever, a nonpneumonia disease. Outbreaks of legionellosis are primarily associated with inhalation of water aerosols or, less commonly, with drinking water containing Legionella bacteria with specific virulence factors not yet identified. Foodborne outbreaks have not been reported (USEPA, 1985).

As discussed in this document, treatment requirements for disinfection of a municipal water supply are thought to provide at least a 3 log reduction of Legionella bacteria (see Section 3.2.2). However, some recontamination may occur in the distribution system due to cross connections and during installation and repair of water mains. It has been hypothesized that the low concentrations of Legionella entering buildings due to these sources may colonize and regrow in hot water systems (USEPA, 1985). Although all of the criteria required for colonization are not known, large institutions, such as hospitals, hotels, and public buildings with recirculating hot water systems seem to be the most susceptible. The control of Legionella in health care institutions, such as hospitals, is particularly important due to the increased susceptibility of many of the patients. The colonization and growth of Legionella in drinking water primarily occurs within the consumer's plumbing systems after the water leaves the distribution system. Therefore, the control of these organisms must be the consumer's responsibility. This appendix is intended to provide guidance to these institutions for the detection and control of the Legionella bacteria.

B.1 MONITORING

It is suggested that hospitals, and other institutions with potential for the growth of Legionella, conduct routine monitoring of

their hot water systems at least quarterly.¹ The analytical procedures for the detection of these organisms can be found in Section 912.I "Legionellaceae" of the 16th edition of Standard Methods. Samples should be taken at, or closely following, the hot water storage reservoir and from a number of shower heads. It is recommended that showers with the least frequent usage be included in the sampling program. Follow-up testing is suggested for all positive indications prior to the initiation of any remedial measures. If the presence of Legionella is confirmed, then remedial measures should be taken. Although the regrowth of Legionella is commonly associated with hot water systems, hot and cold water interconnections may provide a pathway for cross contamination. For this reason, systems detecting Legionella in hot water systems should also monitor their cold water systems.

B.2 TREATMENT

Because the primary route of exposure to Legionella is probably inhalation, rather than ingestion, it is recommended that disinfection procedures include an initial shock treatment period to disinfect shower heads and hot water taps where the bacteria may colonize and later become airborne. The shock treatment period should also include disinfection of hot water tanks. After this time, a point-of entry treatment system can be installed to provide continual disinfection of the hot water system.

B.2.1 Initial Disinfection

The most applicable method for the initial disinfection of shower heads and water taps is heat eradication. The fittings can be removed and held at temperatures greater than 60 C for at least 24 hours. Disinfection of fittings can also be achieved by soaking or rinsing with a strong chlorine solution. When soaking the fittings, a minimum chlorine strength of 50 mg/L should be used for a period of no less than 3 hours. Rinsing

¹ Monitoring frequency based on the reported rate of Legionella regrowth observed during disinfection studies (USEPA, 1985).

with chlorine should be performed with more concentrated solutions. Care must be taken not to corrode the finished surface on the fittings. Commercially available bleaches, for example, are typically 5.25 percent chlorine by weight.

B.2.2 Long-Term Disinfection

Heat - Numerous studies have shown that increasing the hot water temperature to 50 - 70 C over a period of several hours may help to reduce and inhibit Legionella populations. However, some instances of regrowth after 3 to 6 months have been reported. In these cases, the authors have concluded that a periodic schedule of short-term temperature elevation in the hot water may be an effective control against legionellosis (USEPA, 1985; Muraca, 1986). Disinfection by this method also requires periodic flushing of faucets and shower heads with hot water. Although heat eradication is easily implemented and relatively inexpensive, a disadvantage is the potential need for periodic disinfection. The potential for scalding from the unusually hot water also exists (USEPA, 1985; Muraca, et al. 1986).

Chlorination - Several studies have suggested that a free chlorine residual of 4 mg/L will eradicate Legionella growth. There is, however, a possibility for recontamination in areas of the system where the chlorine residual drops below this level. A stringent monitoring program is therefore required to ensure that the proper residual is maintained throughout the system and under varying flow conditions. It may also be necessary to apply a large initial chlorine dose to maintain the 4 mg/L residual. This may cause problems of pipe corrosion and, depending on water quality, high levels of trihalomethanes (THMs).

Ozone - Ozone is the most powerful oxidant used in the potable water industry. One study indicated that an ozone dosage of 1 to 2 mg/L was sufficient to provide a 5 log reduction of Legionella (Muraca, et al. 1986). Ozone is generated by passing a high voltage current of electricity through a stream of dry air or oxygen. The use of high voltage electricity requires proper handling to avoid creating hazardous conditions. The ozone is applied by bubbling the ozone containing gas through the water in a chamber called a contactor.

One of the disadvantages of this system is its complexity. It requires a dry air or oxygen source, a generator, and a contactor sized to provide 2 to 5 minutes of contact time and an ambient ozone monitor. All materials in contact with the ozone must be constructed of special ozone resistant materials to prevent leakage. Leak detection is also required because of the toxic nature of ozone and possible explosive conditions if pure oxygen is used for generation.

Another disadvantage of ozonation is the rapid decomposition of ozone residuals. The half-life of ozone in drinking water is typically around 10 minutes. This makes it difficult, if not impossible, to maintain a residual throughout the water system and may require the use of a supplementary disinfectant such as chlorine or heat. For these reasons it is not thought that ozonation is viable for institutional applications.

Ultraviolet Irradiation - Ultraviolet (UV) light, in the 254 nanometer wavelength range can be used as a disinfectant. UV systems typically contain low-pressure mercury vapor lamps to maximize output in the 254 nm range. Water entering the unit passes through a clear cylinder while the lamp is on, exposing bacteria to the UV light. Because UV light can not pass through ordinary window glass, special glass or quartz sleeves are used to assure adequate exposure.

The intensity of UV irradiation is measured in microwatt-seconds per square centimeter ($\mu\text{W-s/cm}^2$). Several studies have shown a 90 percent reduction of Legionella with a UV dosage of 1000 - 3000 $\mu\text{W-s/cm}^2$, compared to 2000 to 5000 $\mu\text{W-s/cm}^2$ for E. coli, Salmonella and Pseudomonas (USEPA, 1985). In another study, a 5 log reduction of Legionella was achieved at 30,000 $\mu\text{W-s/cm}^2$; and the reduction was more rapid than with both ozone and chlorine disinfection (Muraca, et al. 1986).

The major advantage of UV disinfection is that it does not require the addition of chemicals. This eliminates the storage and feed problems associated with the use of chlorine, chlorine dioxide and chloramines. In addition, the only maintenance required is periodic cleaning of the quartz sleeve and replacement of bulbs. UV monitors are available which measure the light intensity reaching the water and provides a signal to the user when maintenance is required. These monitors are strongly suggested for any application of UV irradiation for disinfection. It should be noted,

however, that these monitors measure light intensity which may not be directly related to disinfection efficiency. The UV lamps should therefore not be operated past the manufacturers use rating even with a continuous UV monitor installed.

Another disadvantage of UV disinfection, as with ozonation, is that a residual is not provided. A supplementary disinfectant may therefore be required to provide protection throughout the system. In addition, turbidity may interfere with UV disinfection by blocking the passage of light to the microorganisms.

B.3 OTHER CONTROL METHODS

In addition to chemical and heat disinfection, there are system modifications which can be made to inhibit Legionella growth. Many institutions have large hot water tanks heated by coils located midway in the tank. This type of design may result in areas near the bottom of the tank which are not hot enough to kill Legionella. Designing tanks for more even distribution of heat may help limit bacterial colonization. In addition, sediment build-up in the bottom of storage tanks provides a surface for colonization. Periodic draining and cleaning may therefore help control growth. Additionally, other studies have found that hot water systems with stand-by hot water tanks used for meeting peak demands, still tested positive for Legionella despite using elevated temperature (55 C) and chlorination (2 ppm) (Fisher-Hoch, et al. 1984.) Stringent procedures for the cleaning, disinfection and monitoring of these stagnant tanks should be set up and followed on a regular basis.

In another study, it was reported that black rubber washers and gaskets supported Legionella growth by providing habitats protected from heat and chlorine. It was found, after replacement of the black rubber washers with Proteus 80 compound washers, that it was not possible to detect Legionella from any of the fixtures (Colbourne, et al. 1984).

B.4 CONCLUSIONS

Legionella bacteria have been identified as the cause of the disease legionellosis, of which the most serious form is Legionnaires Disease. Although conventional water treatment practices are sufficient to provide disinfection of Legionella, regrowth in buildings with large hot water heaters, and especially with recirculating hot water systems, is a significant problem. This problem is of particular concern to health care institutions, such as hospitals, where patients may be more susceptible to the disease.

This guideline suggests a program of quarterly monitoring for Legionella. If the monitoring program suggests a potential problem with these organisms, a two stage disinfection program is suggested consisting of an initial period of shock treatment followed by long term disinfection.

Four methods of disinfection for the control of Legionella were presented in this appendix; heat, chlorination, ozonation, and ultraviolet irradiation. All four of the methods have proven effective in killing Legionella. Ultraviolet irradiation and heat eradication are the suggested methods of disinfection due, primarily, to advantages in monitoring and maintenance. However, site specific factors may make chlorination or ozonation more feasible for certain applications. In addition, it is recommended that all outlets, fixtures and shower heads be inspected and all black rubber washers and gaskets replaced with materials which do not support the growth of Legionella organisms.

One problem associated with the application of point-of-entry treatment systems is the lack of an approved program for certifying performance claims. However, the National Sanitation Foundation (NSF), Ann Arbor, MI an unofficial, non-profit organization, does have a testing program to verify disinfection efficiencies and materials of construction. Certification by the NSF, or other equivalent organizations, is desirable when selecting a treatment system.

APPENDIX C
DETERMINATION OF DISINFECTANT
CONTACT TIME

APPENDIX C
DETERMINATION OF DISINFECTANT CONTACT TIME

As indicated in Section 3, for pipelines, all fluid passing through the pipe is assumed to have a detention time equal to the theoretical or mean residence time at a particular flow rate. However, in mixing basins, storage reservoirs, and other treatment plant process units, utilities will be required to determine the contact time for the calculation of CT through tracer studies or other methods approved by the Primary Agency.

For the purpose of determining compliance with the disinfection requirements of the SWTR, the contact time of mixing basins and storage reservoirs used in calculating CT should be the detention time at which 90 percent of the water passing through the unit is retained within the basin. This detention time was designated as T_{10} according to the convention adopted by Thirumurthi (1969). A profile of the flow through the basin over time can be generated by tracer studies. Information provided by these studies is used for estimating the detention time, T_{10} , for the purpose of calculating CT.

This appendix is divided into two sections. The first section presents a brief synopsis of tracer study methods, procedures, and data evaluation. In addition, examples are presented for conducting hypothetical tracer studies to determine the T_{10} contact time in a clearwell. The second section presents a method of determining T_{10} from theoretical detention times in systems where it is impractical to conduct tracer studies.

C.1 Tracer Studies

C.1.1 Flow conditions

Although detention time is proportional to flow, it is not generally a linear function. Therefore, tracer studies are needed to establish detention times for the range of flow rates experienced within each disinfectant section.

As discussed in Section 3.2, a single flow rate may not characterize the flow through the entire system. With a series of reservoirs,

clearwells, and storage tanks flow will vary between each portion of the system.

In filter plants, the plant flow is relatively uniform from the intake through the filters. An increase or reduction in the intake pumping capacity will impart a proportional change in flow through each process unit prior to and including the filters. Therefore, at a constant intake pumping rate flow variations between disinfectant sections within a treatment plant, excluding clearwells, are likely to be small, and the the design capacity of the plant, or plant flow, can be considered the nominal flow rate through each individual process unit within the plant. Clearwells may operate at a different flow rate than the rest of the plant, depending on the pumping capacity.

Ideally, tracer tests should be performed for at least four flow rates that span the entire range of flow for the section being tested. The flow rates should be separated by approximately equal intervals to span the range of operation, with one near average flow, two greater than average, and one less than average flow. The flows should also be selected so that the highest test flow rate is at least 91 percent of the highest flow rate expected to ever occur in that section. Four data points will assure a good definition of the section's hydraulic profile.

The results of the tracer tests performed for different flow rates should be used to generate plots of T_{10} vs. Q for each section in the system. A smooth line is drawn through the points on each graph to create a curve from which T_{10} may be read for the corresponding Q at peak hourly flow conditions. This procedure is presented in Section C.1.8.

It may not be practical for all systems to conduct studies at four flow rates. The number of tracer tests that are practical to conduct is dependent on site-specific restrictions and resources available to the system. Systems with limited resources can conduct a minimum of one tracer test for each disinfectant section at a flow rate of not less than 91 percent of the highest flow rate experienced at that section. If only one tracer test is performed, the detention time determined by the test may be used to provide a conservative estimate in CT calculations for that section for all flow rates less than or equal to the tracer test flow rate. T_{10} is inversely proportional to flow rate, therefore, the T_{10} at a

flow rate other than that which the tracer study was conducted (T_{10s}) can be determined by multiplying the T_{10} from the tracer study (T_{10T}) by the ratio of the tracer study flow rate to the desired flow rate, i.e.,

$$T_{10s} = T_{10T} \times Q_T/Q_D \text{ where}$$

T_{10s} = T_{10} at system flow rate
 T_{10T} = T_{10} at tracer flow rate
 Q_T = tracer study flow rate
 Q_D = system flow rate

The most accurate tracer test results are obtained when flow is constant through the section during the course of the test. Therefore, the tracer study should be conducted at a constant flow whenever practical. For a treatment plant consisting of two or more equivalent process trains, a constant flow tracer test can be performed on a section of the plant by holding the flow through one of the trains constant while operating the parallel train(s) to absorb any flow variations. Flow variations during tracer tests in systems without parallel trains or with single clearwells and storage reservoirs are more difficult to avoid. In these instances, T_{10} should be recorded at the average flow rate over the course of the test.

C.1.2 Other Tracer Study Considerations

In addition to flow conditions, detention times determined by tracer studies are dependent on the water level in the contact basin. This is particularly pertinent to storage tanks, reservoirs, and clearwells which, in addition to being contact basins for disinfection are also often used as equalization storage for distribution system demands. In such instances, the water levels in the reservoirs vary to meet the system demands. The actual detention time of these contact basins will also vary depending on whether they are emptying or filling.

For some process units, especially sedimentation basins which are operated at a near constant level, that is, flow in equals flow out, the detention time determined by tracer tests is valid for calculating CT when the basin is operating at water levels greater than or equal to the level at which the test was performed. If the water level during testing is

higher than the normal operating level, the resulting concentration profile will predict an erroneously high detention time. Conversely, extremely low water levels during testing may lead to an overly conservative detention time. Therefore, when conducting a tracer study to determine the detention time, a water level at or slightly below, but not above, the normal minimum operating level is recommended.

For many plants, the water level in a clearwell or storage tank varies between high and low levels in response to distribution system demands. In such instances, in order to obtain a conservative estimate of the contact time, the tracer study should be conducted during a period when the tank level is falling (flow out greater than flow in). This procedure will provide a detention time for the contact basin which is also valid when the water level is rising (flow out less than flow in) from a level which is at or above the level when the T_{10} was determined by the tracer study. Whether the water level is constant or variable, the tracer study for each section should be repeated for several different flows, as described in the previous section.

For clearwells which are operated with extreme variations in water level, maintaining a CT to comply with inactivation requirements may be impractical. Under such operating conditions, a reliable detention time is not provided for disinfection. However, the system may install a weir to ensure a minimum water level and provide a reliable detention time.

Systems comprised of storage reservoirs that experience seasonal variations in water levels may perform tracer studies during the various seasonal conditions. For these systems, tracer tests should be conducted at several flow rates and representative water levels that occur for each seasonal condition. The results of these tests can be used to develop hydraulic profiles of the reservoir for each water level. These profiles can be plotted on the same axis of T_{10} vs. Q and may be used for calculating CT for different water levels and flow rates.

Detention time may also be influenced by differences in water temperature within the system. For plants with potential for thermal stratification, additional tracer studies are suggested under the various seasonal conditions which are likely to occur. The contact times determined by the tracer studies under the various seasonal conditions

should remain valid as long as no physical changes are made to the mixing basin(s) or storage reservoir(s).

As defined in Section 3.2.2, the portion of the system with a measurable contact time between two points of disinfection or residual monitoring is referred to as a section. For systems which apply disinfectant(s) at more than one point, or choose to profile the residual from one point of application, tracer studies should be conducted to determine T_{10} for each section containing process unit(s). The T_{10} for a section may or may not include a length of pipe and is used along with the residual disinfectant concentration prior to the next disinfectant application or monitoring point to determine the $CT_{2,10}$ for that section. The inactivation ratio for the section is then determined. The total inactivation and log inactivation achieved in the system can then be determined by summing the inactivation ratios for all sections as explained in Section 3.2.2.

For systems that have two or more units of identical size and configuration, tracer studies only need to be conducted on one of the units. The resulting graph of T_{10} vs. flow can be used to determine T_{10} for all identical units.

Systems with more than one section in the treatment plant may determine T_{10} for each section

- by individual tracer studies through each section, or
- by one tracer study across the system

If possible, tracer studies should be conducted on each section to determine the T_{10} for each section. In order to minimize the time needed to conduct studies on each section, the tracer studies should be started at the last section of the treatment train prior to the first customer and completed with the first section of the system. Conducting the tracer studies in this order will prevent the interference of residual tracer material with subsequent studies.

However, it may not always be practical for systems to conduct tracer studies for each section because of time and manpower constraints. In these cases, one tracer study may be used to determine the T_{10} values

for all of the sections at one flow rate. This procedure involves the following steps:

1. Add tracer at the beginning of the furthest upstream disinfection section.
2. Measure the tracer concentration at the end of each disinfection section.
3. Determine the T_{10} to each monitoring point as outlined in the data evaluation examples presented in Section C.1.7.
4. Subtract T_{10} values of each of the upstream sections from the overall T_{10} value to determine the T_{10} of each downstream section.

This approach is valid for a series of two or more consecutive sections as long as all process units within the sections experience the same flow condition. This approach is illustrated by Hudson (1975) in which step-dose tracer tests were employed to evaluate the baffling characteristics of flocculators and settling basins at six water treatment plants. At one plant, tracer chemical was added to the rapid mix, which represented the beginning of the furthest upstream disinfection section in the system. Samples were collected from the flocculator and settling basin outlets and analyzed to determine the residence-time characteristics for each section. Tracer measurements at the flocculator outlet indicated an approximate T_{10} of 5 minutes through the rapid mix, interbasin piping and flocculator. Based on tracer concentration monitoring at the settling basin outlet, an approximate T_{10} of 70 minutes was determined for the combined sections, including the rapid mix, interbasin piping, flocculator, and settling basin. The flocculator T_{10} of 5 minutes was subtracted from the combined sections' T_{10} of 70 minutes, to determine the T_{10} for the settling basin alone, 65 minutes.

This approach may also be applied in cases where disinfectant application and/or residual monitoring is discontinued at any point between two or more sections with known T_{10} values. These T_{10} values may be summed to obtain an equivalent T_{10} for the combined sections.

For ozone contactors, flocculators or any basin containing mixing, tracer studies should be conducted for the range of mixing used in the

process. In ozone contactors, air or oxygen should be added in lieu of ozone to prevent degradation of the tracer. The flow rate of air or oxygen used for the contactor should be applied during the study to simulate actual operation. Tracer studies should then be conducted at several air/oxygen to water ratios to provide data for the complete range of ratios used at the plant. For flocculators, tracer studies should be conducted for various mixing intensities to provide data for the complete range of operations.

C.1.3 Tracer Study Methods

This section discusses the two most common methods of tracer addition employed in water treatment evaluations, the step-dose method and the slug-dose method. Tracer study methods involve the application of chemical dosages to a system and tracking the resulting effluent concentration as a function of time. The effluent concentration profile is evaluated to determine the detention time, T_{10} .

While both tracer test methods can use the same tracer materials and involve measuring the concentration of tracer with time, each has distinct advantages and disadvantages with respect to tracer addition procedures and analysis of results.

The step-dose method entails introduction of a tracer chemical at a constant dosage until the concentration at the desired end point reaches a steady-state level. Step-dose tracer studies are frequently employed in drinking water applications for the following reasons:

- the resulting normalized concentration vs. time profile is directly used to determine, T_{10} , the detention time required for calculating CT
- very often, the necessary feed equipment is available to provide a constant rate of application of the tracer chemical

One other advantage of the step-dose method is that the data may be verified by comparing the concentration versus elapsed time profile for samples collected at the start of dosing with the profile obtained when the tracer feed is discontinued.

Alternatively, with the slug-dose method, a large instantaneous dose of tracer is added to the incoming water and samples are taken at the exit of the unit over time as the tracer passes through the unit. A disadvantage of this technique is that very concentrated solutions are needed for the dose in order to adequately define the concentration versus time profile. Intensive mixing is therefore required to minimize potential density-current effects and to obtain a uniform distribution of the instantaneous tracer dose across the basin. This is inherently difficult under water flow conditions often existing at inlets to basins. Other disadvantages of using the slug-dose method include:

- the concentration and volume of the instantaneous tracer dose must be carefully computed to provide an adequate tracer profile at the effluent of the basin
- the resulting concentration vs. time profile cannot be used to directly determine T_{10} without further manipulation
- a mass balance on the treatment section is required to determine whether the tracer was completely recovered

One advantage of this method is that it may be applied where chemical feed equipment is not available at the desired point of addition, or where the equipment available does not have the capacity to provide the necessary concentration of the chosen tracer chemical. Although, in general, the step-dose procedure offers the greatest simplicity, both methods are theoretically equivalent for determining T_{10} . Either method is acceptable for conducting drinking water tracer studies, and the choice of the method may be determined by site-specific constraints or the system's experience.

C.1.4 Tracer Selection

An important step in any tracer study is the selection of a chemical to be used as the tracer. Ideally, the selected tracer chemical should be readily available, conservative (that is, not consumed or removed during treatment), easily monitored, and acceptable for use in potable water supplies. Historically, many chemicals have been used in tracer studies that do not satisfy all of these criteria, including potassium permanganate, alum, chlorine, and sodium carbonate. However, chloride and fluoride are

the most common tracer chemicals employed in drinking water plants that are nontoxic and approved for potable water use. Rhodamine WT can be used as a fluorescent tracer in water flow studies in accordance with the following guidelines:

- Raw water concentrations should be limited to a maximum concentration of 10 mg/L.
- Drinking water concentrations should not exceed 0.1 ug/L.
- Studies which results in human exposure to the dye must be brief and infrequent.
- Concentrations as low as 2 ug/L can be used in tracer studies because of the low detection level in the range of 0.1 to 0.2 ug/L.

The use of Rhodamine B as a tracer in water flow studies is not recommended by the EPA.

The choice of a tracer chemical can be made based, in part, on the selected dosing method and also on the availability of chemical feeding equipment. For example, the high density of concentrated salt solutions and their potential for inducing density currents, usually precludes chloride and fluoride as the selected chemical for slug-dose tracer tests.

Fluoride can be a convenient tracer chemical for step-dose tracer tests of clearwells because it is frequently applied for finished water treatment. However, when fluoride is used in tracer tests on clarifiers, allowances should be made for fluoride that is absorbed on floc and settles out of water (Hudson, 1975). Additional considerations when using fluoride in tracer studies include:

- it is difficult to detect at low levels
- many states impose a finished water limitation of 1 mg/L
- the federal secondary and primary drinking water standards (MCLs) for fluoride are 2 and 4 mg/L, respectively

The use of fluoride is only recommended in cases where the feed equipment is already in place for safety reasons.

In instances where only one of two or more parallel units is tested, flow from the other units would dilute the tracer concentration prior to leaving the plant and entering the distribution system. Therefore, the impact of drinking water standards on the use of fluoride and other tracer chemicals can be alleviated in some cases.

C.1.5 Tracer Addition

The tracer chemical should be added at the same point(s) in the treatment train as the disinfectant to be used in the CT calculations.

C.1.5.1 Step-dose Method

The duration of tracer addition is dependent on the volume of the basin, and hence, its theoretical detention time. In order to approach a steady-state concentration in the water exiting the basin, tracer addition and sampling should usually be continued for a period of two to three times the theoretical detention time (Hudson, 1981). It is not necessary to reach a steady state concentration in the exiting water to determine T_{10} , however, it is necessary to determine tracer recovery. It is recommended that the tracer recovery be determined to identify hydraulic characteristics or density problems. Generally, a 90 percent recovery is considered to provide reliable results for the evaluation of T_{10} .

In all cases, the tracer chemical should be dosed in sufficient concentration to easily monitor a residual at the basin outlet throughout the test. The required tracer chemical concentration, is generally dependent upon the nature of the chosen tracer chemical, including its background concentration, and the mixing characteristics of the basin to be tested. Recommended chloride doses on the order of 20 mg/L (Hudson, 1975) should be used for step-method tracer studies where the background chloride level is less than 10 mg/L. Also, fluoride concentrations as low as 1.0 to 1.5 mg/L are practical when the raw water fluoride level is not significant (Hudson, 1975). However, tracer studies conducted on systems suffering from serious shortcircuiting of flow may require substantially larger step-doses. This would be necessary to detect the tracer chemical and to adequately define the effluent tracer concentration profile.

C.1.5.2 Slug-dose Method

The duration of tracer measurements using the slug-dose method is also dependent on the volume of the basin, and hence, its theoretical detention time. In general, samples should be collected for at least twice the basin's theoretical detention time, or until tracer concentrations are detected near background levels. In order to get reliable results for T_{10} values using the slug-dose method, it is recommended that the total mass of tracer recovered be approximately 90 percent of the mass applied. This guideline presents the need to sample until the tracer concentration recedes to the background level. The total mass recovered during testing will not be known until completion of the testing and analysis of the data collected. The sampling period needed is very site specific. Therefore, it may be helpful to conduct a first run tracer test as a screen to identify the appropriate sampling period for gathering data to determine T_{10} .

Tracer addition for slug-dose method tests should be instantaneous and provide uniformly mixed distribution of the chemical. Tracer addition is considered instantaneous if the dosing time does not exceed 2 percent of the basin's theoretical detention time (Marske and Boyle, 1973). One recommended procedure for achieving instantaneous tracer dosing is to apply the chemical by gravity flow through a funnel and hose apparatus. This method is also beneficial because it provides a means of standardization, which is necessary to obtain reproducible results.

The mass of tracer chemical to be added is determined by the desired theoretical concentration and basin size. The mass of tracer added in slug-dose tracer tests should be the minimum mass needed to obtain detectable residual measurements to generate a concentration profile. As a guideline, the theoretical concentration for the slug-dose method should be comparable to the constant dose applied in step-dose tracer tests, i.e., 10 to 20 mg/L and 1 to 2 mg/L for chloride and fluoride, respectively. The maximum mass of tracer chemical needed is calculated by multiplying the theoretical concentration by the total basin volume. This is appropriate for systems with high dispersion and/or mixing. This quantity is diluted as required to apply an instantaneous dose, and minimize density effects. It should be noted that the mass applied is not

likely to get completely mixed throughout the total volume of the basin. Therefore, the detected concentration might exceed theoretical concentrations based on the total volume of the basin. For these cases, the mass of chemical to be added can be determined by multiplying the theoretical concentration by only a portion of the basin volume. An example of this is shown in Section C.1.7.2 for a slug-dose tracer study. In cases where the tracer concentration in the effluent must be maintained below a specified level, it may be necessary to conduct a preliminary test run with a minimum tracer dose to identify the appropriate dose for determining T_{10} without exceeding this level.

C.1.6 Test Procedure

In preparation for beginning a tracer study, the raw water background concentration of the chosen tracer chemical must be established. The background concentration is essential, not only for aiding in the selection of the tracer dosage, but also to facilitate proper evaluation of the data.

The background tracer concentration should be determined by monitoring for the tracer chemical prior to beginning the test. The sampling point(s) for the pre-tracer study monitoring should be the same as the points to be used for residual monitoring to determine CT values. The monitoring procedure is outlined in the following steps:

- If the tracer chemical is normally added for treatment, discontinue its addition to the water in sufficient time to permit the tracer concentration to recede to its background level before the test is begun.
- Prior to the start of the test, regardless of whether the chosen tracer material is a treatment chemical, the tracer concentration in the water is monitored at the sampling point where the disinfectant residual will be measured for CT calculations.
- If a background tracer concentration is detected, monitor it until a constant concentration, at or below the raw water background level is achieved. This measured concentration is the baseline tracer concentration.

Following the determination of the tracer dosage, feed and monitoring point(s), and a baseline tracer concentration, tracer testing can begin.

Equal sampling intervals, as could be obtained from automatic sampling, are not required for either tracer study method. However, using equal sample intervals for the slug-dose method can simplify the analysis of the data. During testing, the time and tracer residual of each measurement should also be recorded on a data sheet. In addition, the water level, flow, and temperature should be recorded during the test.

C.1.6.1 Step-dose Method

At time zero, the tracer chemical feed will be started and left at a constant rate for the duration of the test. Over the course of the test, the tracer residual should be monitored at the required sampling point(s) at a frequency determined by the overall detention time and site specific considerations. As a general guideline, sampling at intervals of 2 to 5 minutes should provide data for a well-defined plot of tracer concentration vs. time. If on-site analysis is available, less frequent residual monitoring may be possible until a change in residual concentration is first detected. As a guideline, in systems with a theoretical detention time greater than 4 hours, sampling may be conducted every 10 minutes for the first 30 minutes, or until a tracer concentration above the baseline level is first detected. In general, shorter sampling intervals enable better characterization of concentration changes; therefore, sampling should be conducted at 2 to 5-minute intervals from the time that a concentration change is first observed until the residual concentration reaches a steady-state value. A reasonable sampling interval should be chosen based on the overall detention time of the unit being tested.

If verification of the test is desired, the tracer feed should be discontinued, and the receding tracer concentration at the effluent should be monitored at the same frequency until tracer concentrations corresponding to the background level are detected. The time at which tracer feed is stopped is time zero for the receding tracer test and must be noted. The receding tracer test will provide a replicate set of measurements which can be compared with data derived from the rising tracer concentration versus time curve. For systems which currently feed the tracer chemical,

the receding curve may be generated from the time the feed is turned off to determine the background concentration level.

C.1.6.2 Slug-dose Method

At time zero for the slug-dose method, a large instantaneous dose of tracer will be added to the influent of the unit. The same sampling locations and frequencies described for step-dose method tests also apply to slug-dose method tracer studies. One exception with this method is that the tracer concentration profile will not equilibrate to a steady state concentration. Because of this, the tracer should be monitored frequently enough to ensure acquisition of data needed to identify the peak tracer concentration.

Slug-dose method tests should be checked by performing a material balance to ensure that all of the tracer fed is recovered, or, mass applied equals mass discharged.

C.1.7 Data Evaluation

Data from tracer studies should be summarized in tables of time and residual concentration. These data are then analyzed to determine the detention time, T_{10} , to be used in calculating CT. Tracer test data from either the step or slug-dose method can be evaluated graphically, numerically, or by a combination of these techniques.

C.1.7.1 Step-dose Method

The graphical method of evaluating step-dose test data involves plotting a graph of dimensionless concentration versus time and reading the value for T_{10} directly from the graph at the appropriate dimensionless concentration. Alternatively, the data from step-dose tracer studies may be evaluated numerically by developing a semi-logarithmic plot of the dimensionless data. The semi-logarithmic plot allows a straight line to be drawn through the data. The resulting equation of the line is used to calculate the T_{10} value, assuming that the correlation coefficient indicates a good statistical fit (0.9 or above). Scattered data points from step-dose tracer tests are discredited by drawing a smooth curve through the data.

An illustration of the T_{10} determination will be presented in an example of the data evaluation required for a clearwell tracer study.

C.1.7.2 Slug-dose Method

Data from slug-dose tracer tests is analyzed by converting it to the mathematically equivalent step-dose data and using techniques discussed in Section C.1.7.1 to determine T_{10} . A graph of dimensionless concentration versus time should be drawn which represents the results of a slug-dose tracer test. The key to converting between the data forms is obtaining the total area under the slug-dose data curve. This area is found by graphically or numerically integrating the curve. The conversion to step-dose data is then completed in several mathematical steps involving the total area.

A graphical technique for converting the slug-dose data involves physically measuring the area using a planimeter. The planimeter is an instrument used to measure the area of a plane closed curve by tracing its boundary. Calibration of this instrument to the scale of the graph is required to obtain meaningful readings.

The rectangle rule is a simple numerical integration method which approximates the total area under the curve as the sum of the areas of individual rectangles. These rectangles have heights and widths equal to the residual concentration and sampling interval (time) for each data point on the curve, respectively. Once the data has been converted, T_{10} may be determined in the same manner as data from step-dose tracer tests.

Slug-dose concentration profiles can have many shapes, depending on the hydraulics of the basin. Therefore, slug-dose data points should not be discredited by drawing a smooth curve through the data prior to its conversion to step-dose data. The steps and specific details involved with evaluating data from both tracer study methods are illustrated in the following examples.

Example for Determining T_{10} in a Clearwell

Two tracer studies employing the step-dose and slug-dose methods of tracer addition were conducted for a clearwell with a theoretical detention time, T , of 30 minutes at an average flow of 2.5 MGD. Because fluoride is added at the inlet to the clearwell as a water treatment chemical, necessary feed equipment was in place for dosing a constant

concentration of fluoride throughout the step-dose tracer test. Based on this convenience, fluoride was chosen as the tracer chemical for the step-dose method test. Fluoride was also selected as the tracer chemical for the slug-dose method test. Prior to the start of testing, a fluoride baseline concentration of 0.2 mg/L was established for the water exiting the clearwell.

Step-dose Method Test

For the step-dose test a constant fluoride dosage of 2.0 mg/L was added to the clearwell inlet. Fluoride levels in the clearwell effluent were monitored and recorded every 3 minutes. The raw tracer study data, along with the results of further analyses are shown in Table C-1.

The steps in evaluating the raw data shown in the first column of Table C-1 are as follows. First, the baseline fluoride concentration, 0.2 mg/L, is subtracted from the measured concentration to give the fluoride concentration resulting from the tracer study addition alone. For example, at elapsed time = 39 minutes, the tracer fluoride concentration, C, is obtained as follows:

$$\begin{aligned} C &= C_{\text{measured}} - C_{\text{baseline}} \\ &= 1.85 \text{ mg/L} - 0.2 \text{ mg/L} \\ &= 1.65 \text{ mg/L} \end{aligned}$$

This calculation was repeated at each time interval to obtain the data shown in the third column of Table C-1. As indicated, the fluoride concentration rises from 0 mg/L at t = 0 minutes to the applied fluoride dosage of 2 mg/L, at t = 63 minutes.

The next step is to develop dimensionless concentrations by dividing the tracer concentrations in the second column of Table C-1 by the applied fluoride dosage, $C_0 = 2 \text{ mg/L}$. For time = 39 minutes, C/C_0 is calculated as follows:

$$\begin{aligned} C/C_0 &= (1.65 \text{ mg/L}) / (2.0 \text{ mg/L}) \\ &= 0.82 \end{aligned}$$

The resulting dimensionless data, presented in the fourth column of Table C-1, is the basis for completing the determination of T_{10} by either the graphical or numerical method.

TABLE C-1

CLEARWELL DATA--STEP-DOSE TRACER TEST^(1,2,3)

<u>t. minutes</u>	<u>Fluoride Concentration</u>		
	<u>Measured, mg/L</u>	<u>Tracer, mg/L</u>	<u>Dimensionless, C/Co</u>
0	0.20	0	0
3	0.20	0	0
6	0.20	0	0
9	0.20	0	0
12	0.29	0.09	0.045
15	0.67	0.47	0.24
18	0.94	0.74	0.37
21	1.04	0.84	0.42
24	1.44	1.24	0.62
27	1.55	1.35	0.68
30	1.52	1.32	0.66
33	1.73	1.53	0.76
36	1.93	1.73	0.86
39	1.85	1.65	0.82
42	1.92	1.72	0.86
45	2.02	1.82	0.91
48	1.97	1.77	0.88
51	1.84	1.64	0.82
54	2.06	1.86	0.93
57	2.05	1.85	0.92
60	2.10	1.90	0.95
63	2.14	1.94	0.96

Notes:

1. Baseline conc. = 0.2 mg/L, fluoride dose = 2.0 mg/L
2. Measured conc. = Tracer conc. + Baseline conc.
3. Tracer conc. = Measured conc. - Baseline conc.

In order to determine T_{10} by the graphical method, a plot of C/Co vs. time should be generated using the data in Table C-1. A smooth curve should be drawn through the data as shown on Figure C-1.

T_{10} is read directly from the graph at a dimensionless concentration (C/Co) corresponding to the time for which 10 percent of the tracer has passed at the effluent end of the contact basin (T_{10}). For step-dose method tracer studies, this dimensionless concentration is $C/Co = 0.10$ (Levenspiel, 1972).

T_{10} should be read directly from Figure C-1 at $C/Co = 0.1$ by first drawing a horizontal line ($C/Co = 0.1$) from the Y-axis ($t = 0$) to its intersection with the smooth curve drawn through the data. At this point of intersection, the time read from the X-axis is T_{10} and may be found by extending a vertical line downward to the X-axis. These steps were performed as illustrated on Figure C-1, resulting in a value for T_{10} of approximately 13 minutes.

For the numerical method of data analysis, several additional steps are required to obtain T_{10} from the data in the fourth column of Table C-1. The forms of data necessary for determining T_{10} through a numerical solution are $\log_{10}(1-C/Co)$ and t/T , the elapsed time divided by the theoretical residence time. These are obtained by performing the required mathematical operations on the data in the fourth column of Table C-1. For example, recalling that the theoretical detention time, T , is 30 minutes, the values for $\log_{10}(1-C/Co)$ and t/T are computed as follows for the data at $t = 39$ minutes:

$$\begin{aligned}\log_{10}(1-C/Co) &= \log_{10}(1-0.82) \\ &= \log_{10}(0.18) \\ &= -0.757\end{aligned}$$

$$t/T = 39 \text{ min}/30 \text{ min} = 1.3$$

This calculation was repeated at each time interval to obtain the data shown in Table C-2. These data should be linearly regressed as $\log_{10}(1-C/Co)$ versus t/T to obtain the fitted straight-line parameters to the following equation:

FIGURE C-1
C/Co vs. Time
Graphical Analysis for T10

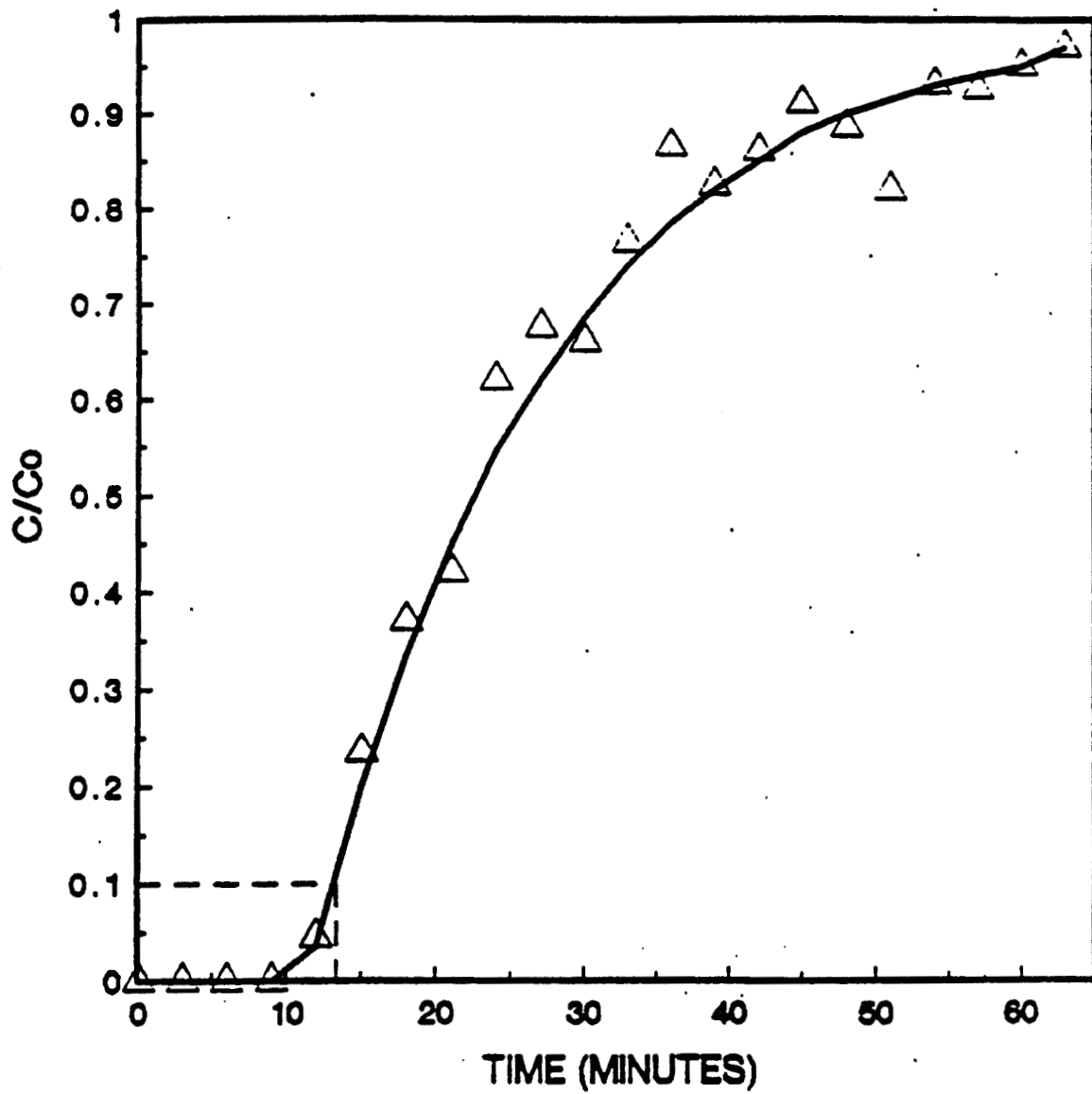

TABLE C-2

DATA FOR NUMERICAL DETERMINATION OF T_{10}

<u>t/T</u>	<u>$\log_{10}(1-C/C_0)$</u>
0	0
0.1	0
0.2	0
0.3	0
0.4	-0.020
0.5	-0.116
0.6	-0.201
0.7	-0.237
0.8	-0.420
0.9	-0.488
1.0	-0.468
1.1	-0.629
1.2	-0.870
1.3	-0.757
1.4	-0.854
1.5	-1.046
1.6	-0.939
1.7	-0.745
1.8	-1.155
1.9	-1.125
2.0	-1.301
2.1	-1.532

$$\log_{10}(1-C/Co) = m(t/T) + b \quad (1)$$

In equation 1, m and b are the slope and intercept, respectively, for a plot of $\log_{10}(1-C/Co)$ vs. t/T . This equation can be used to calculate T_{10} , assuming that the correlation coefficient for the fitted data indicates a good statistical fit (0.9 or above).

A linear regression analysis was performed on the data in Table C-2, resulting in the following straight-line parameters:

$$\begin{aligned} \text{slope} = m &= -0.774 \\ \text{intercept} = b &= 0.251 \\ \text{correlation coefficient} &= 0.93 \end{aligned}$$

Although these numbers were obtained numerically, a plot of $\log_{10}(1-C/Co)$ versus t/T is shown for illustrative purposes on Figure C-2 for the data in Table C-2. In this analysis, data for time = 0 through 9 minutes were excluded because fluoride concentrations above the baseline level were not observed in the clearwell effluent until $t = 12$ minutes.

Equation 1 is then rearranged in the following form to facilitate a solution for T_{10} :

$$T_{10}/T = (\log_{10}(1 - 0.1) - b)/m \quad (2)$$

In equation 2, as with graphical method, T_{10} is determined at the time for which $C/Co = 0.1$. Therefore, in equation 2, C/Co has been replaced by 0.1 and t (time) by T_{10} . To obtain a solution for T_{10} , the values of the slope, intercept, and theoretical detention time are substituted as follows:

$$\begin{aligned} T_{10}/30 \text{ min.} &= (\log_{10}(1 - 0.1) - 0.251)/(-0.774) \\ T_{10} &= 12 \text{ minutes} \end{aligned}$$

In summary both the graphical and numerical methods of data reduction resulted in comparable values for T_{10} . With the numerical method, T_{10} was determined as the solution to an equation based on the

straight-line parameters to a linear regression analysis of the tracer study data instead of an "eyeball" estimate from a data plot.

Slug-dose Method Test

A slug-dose tracer test was also performed on the clearwell at a flow rate of 2.5 mgd. A theoretical clearwell fluoride concentration of 2.2 mg/L was selected. The fluoride dosing volume and concentration were determined from the following considerations:

Dosing Volume

- The fluoride injection apparatus consisted of a funnel and a length of copper tubing. This apparatus provided a constant volumetric feeding rate of 7.5 liters per minute (L/min) under gravity flow conditions.
- At a flow rate of 2.5 mgd, the clearwell has a theoretical detention time of 30 minutes. Since the duration of tracer injection should be less than 2 percent of the clearwell's theoretical detention time for an instantaneous dose, the maximum duration of fluoride injection was:

$$\text{Max. dosing time} = 30 \text{ minutes} \times .02 = 0.6 \text{ minutes}$$

- At a dosing rate of 7.5 L/min, the maximum fluoride dosing volume is calculated to be:

$$\text{Max. dosing volume} = 7.5 \text{ L/min.} \times 0.6 \text{ minutes} = 4.5 \text{ L}$$

For this tracer test, a dosing volume of 4 liters was selected, providing an instantaneous fluoride dose in 1.8 percent of the theoretical detention time.

Fluoride Concentration

- The theoretical detention time of the clearwell, 30 minutes, was calculated by dividing the clearwell volume, 52,100 gallons or 197,200 liters, by the average flow rate through the clearwell, 2.5 mgd.
- Assuming the tracer is completely dispersed throughout the total volume of the clearwell, the mass of fluoride required to achieve a theoretical concentration of 2.2 mg/L is calculated as follows:

$$\text{Fluoride mass (initial)} = 2.2 \text{ mg/L} \times 197,200 \text{ L} \times \frac{1 \text{ g}}{1000 \text{ mg}} = 434 \text{ g}$$

FIGURE C-2
1-C/Co vs. t/T
Numerical Analysis for T10

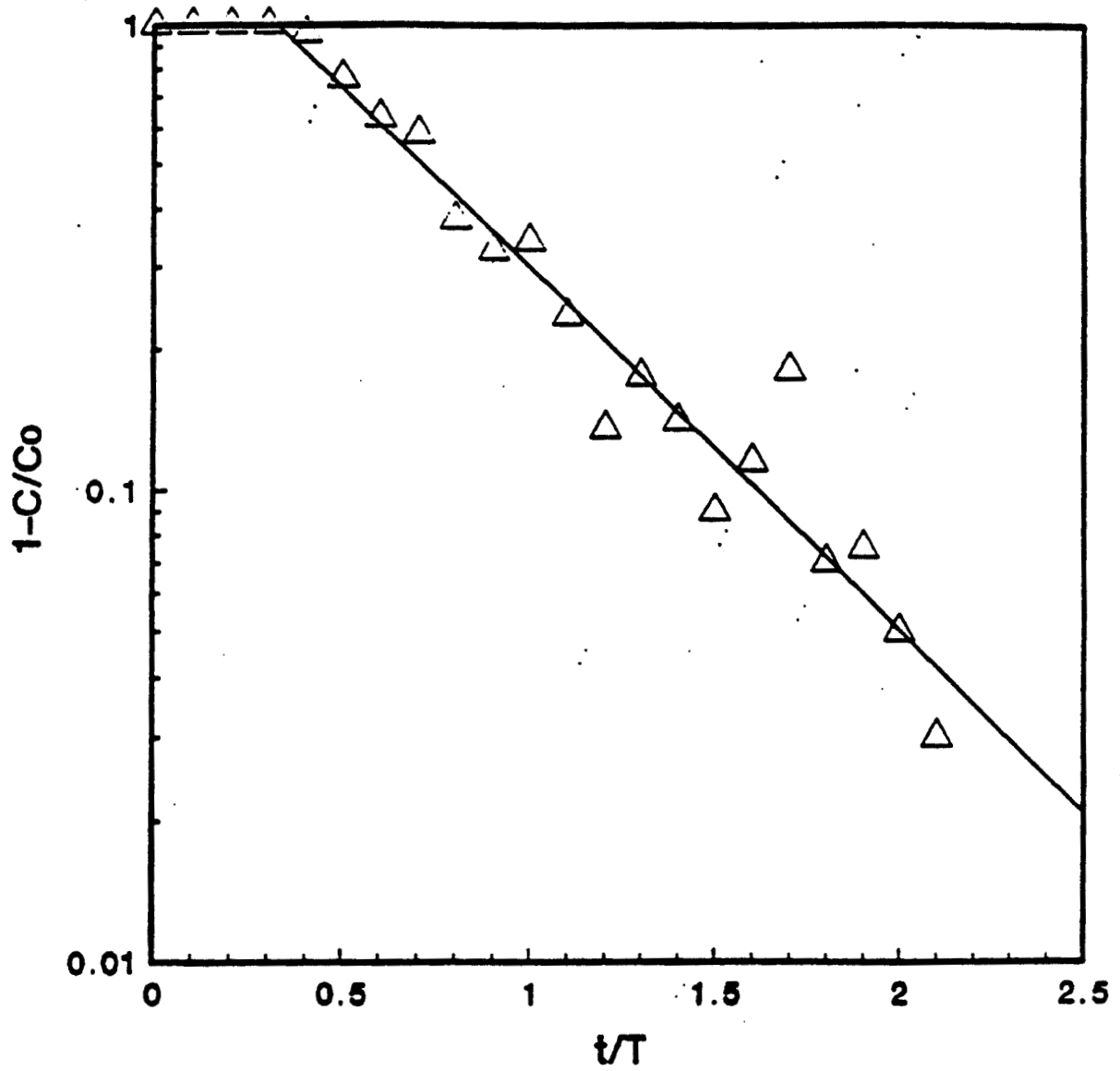

Slope, $m = -0.774$
Intercept, $b = 0.251$

Correlation Coefficient = 0.93

- The concentration of the instantaneous fluoride dose is determined by dividing this mass by the dosing volume, 4 liters:

$$\text{Fluoride concentration} = \frac{434 \text{ g}}{4 \text{ L}} = 109 \text{ g/L}$$

Fluoride levels in the exit to the clearwell were monitored and recorded every 3 minutes. The raw slug-dose tracer test data are shown in Table C-3.

The first step in evaluating the data for different times is to subtract the baseline fluoride concentration, 0.2 mg/L, from the measured concentration at each sampling interval (Table C-3). This is the same as the first step used to evaluate step-dose method data and gives the fluoride concentrations resulting from the tracer addition alone, shown in the third column of Table C-3. As indicated, the fluoride concentration rises from 0 mg/L at $t = 0$ minutes to the peak concentration of 3.6 mg/L at $t = 18$ minutes. The exiting fluoride concentration gradually recedes to near zero at $t = 63$ minutes. It should be noted that a maximum fluoride concentration of 2.2 mg/L is based on assuming complete mixing of the tracer added throughout the total clearwell volume. However, as shown in Table C-3, the fluoride concentrations in the clearwell effluent exceeded 2.2 mg/L for about 6 minutes between 14 and 20 minutes. These higher peak concentrations are caused by the dispersion of tracer throughout only a portion of the total clearwell volume. If a lower tracer concentration is needed in the effluent because of local or federal regulations, the mass to be added should be decreased accordingly.

The dimensionless concentrations in the fourth column of Table C-3 were obtained by dividing the tracer concentrations in the third column by the clearwell's theoretical concentration, $C_0 = 2.2$ mg/L. These dimensionless concentrations were then plotted as a function of time, as is shown by the slug-dose data on Figure C-3. These data points were connected by straight lines, resulting in a somewhat jagged curve.

The next step in evaluating slug-dose data is to determine the total area under the slug-dose data curve on Figure C-3. Two methods exist for finding this area -- graphical and numerical. The graphical method is

TABLE C-3

CLEARWELL DATA -- SLUG-DOSE TRACER TEST (1,2,3)

<u>t, minutes</u>	<u>Fluoride Concentration</u>		
	<u>Measured, mg/L</u>	<u>Tracer, mg/L</u>	<u>Dimensionless, C/Co</u>
0	0.2	0	0
3	0.2	0	0
6	0.2	0	0
9	0.2	0	0
12	1.2	1	0.45
15	3.6	3.4	1.55
18	3.8	3.6	1.64
21	2.0	1.8	0.82
24	2.1	1.9	0.86
27	1.4	1.2	0.55
30	1.3	1.1	0.50
33	1.5	1.3	0.59
36	1.0	0.8	0.36
39	0.6	0.4	0.18
42	1.0	0.8	0.36
45	0.6	0.4	0.18
48	0.8	0.6	0.27
51	0.6	0.4	0.18
54	0.4	0.2	0.09
57	0.5	0.3	0.14
60	0.6	0.4	0.18
63	0.4	0.2	0.09

Notes:

1. Measured conc. = Tracer conc. + Baseline conc.
2. Baseline conc. = 0.2 mg/L, fluoride dose = 109 g/L, theoretical conc. = 2.2 mg/L
3. Tracer conc. = Measured conc. - Baseline conc.

FIGURE C-3
C/Co vs. Time
Conversion of Slug-to Step-Dose Data

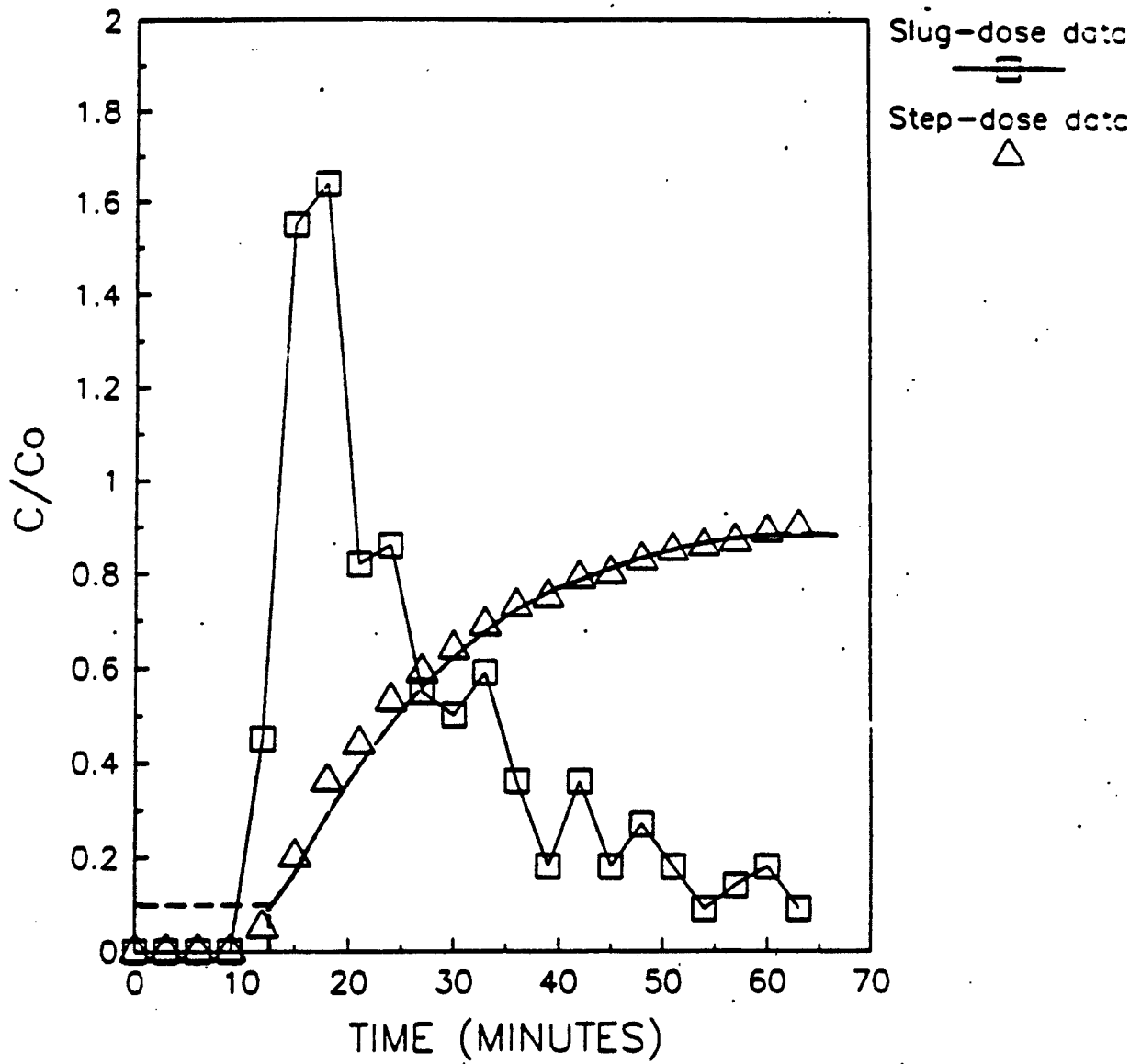

based on a physical measurement of the area using a planimeter. This involves calibration of the instrument to define the units conversion and tracing the outline of the curve to determine the area. The results of performing this procedure may vary depending on instrument accuracy and measurement technique. Therefore, only an illustration of the numerical technique for finding the area under the slug-dose curve will be presented for this example.

The area obtained by either the graphical or numerical method would be similar. Furthermore, once the area is found, the remaining steps involved with converting the data to the step-dose response are the same.

Table C-4 summarizes the results of determining the total area using a numerical integration technique called the rectangle rule. The first and second columns in Table C-4 are the sampling time and fluoride concentration resulting from tracer addition alone, respectively. The steps in applying these data are as follows. First, the sampling time interval, 3 minutes, is multiplied by the fluoride concentration at the end of the 3-minute interval to give the incremental area, in units of milligram minutes per liter. For example, at elapsed time, $t = 39$ minutes, the incremental area is obtained as follows:

$$\begin{aligned} \text{Incremental area} &= \text{sampling time interval} \times \text{fluoride conc.} \\ &= (39-36) \text{ minutes} \times 0.4 \text{ mg/L} \\ &= 1.2 \text{ mg-min/L} \end{aligned}$$

This calculation was repeated at each time interval to obtain the data shown in the third column of Table C-4.

If the data had been obtained at unequal sampling intervals, then the incremental area for each interval would be obtained by multiplying the fluoride concentration at the end of each interval by the time duration of the interval. This convention also requires that the incremental area be zero at the first sampling point, regardless of the fluoride concentration at that time.

As is shown in Table C-4, all incremental areas were summed to obtain 59.4 mg-min/L, the total area under the slug-dose tracer test curve. This number represents the total mass of fluoride that was

detected during the course of the tracer test divided by the average flow rate through the clearwell.

To complete the conversion of slug-dose data to its equivalent step-dose response requires two additional steps. The first involves summing, consecutively, the incremental areas in the third column of Table C-4 to obtain the cumulative area at the end of each sampling interval. For example, the cumulative area at time, $t = 27$ minutes is found as follows:

$$\begin{aligned}\text{Cumulative area} &= 0 + 0 + 0 + 0 + 3 + 10.2 + 10.8 + 5.4 + 5.7 + 3.6 \\ &= 38.7 \text{ mg-min/L}\end{aligned}$$

The cumulative areas for each interval are recorded in the fourth column of Table C-4.

The final step in converting slug-dose data involves dividing the cumulative area at each interval by the total mass applied. Total area based on applied mass is calculated as follows:

$$\begin{aligned}\text{Total area mass applied/average flow} &= 434 \text{ g} \times 1000 \frac{\text{mg}}{\text{g}} / 6,570 \frac{\text{L}}{\text{min}} \\ &= 66.1 \frac{\text{mg-min}}{\text{L}}\end{aligned}$$

For time = 39 minutes, the resulting step-dose data point is calculated as follows:

$$\begin{aligned}C/C_0 &= 49.5 \text{ mg-min/L} / 59.4 \text{ mg-min/L} \\ &= 0.83\end{aligned}$$

The result of performing this operation at each sampling interval is the equivalent step-dose data. These data points are shown in the fifth column of Table C-4 and are also plotted on Figure C-3 to facilitate a graphical determination of T_{10} . A smooth curve was fitted to the step-dose data as shown on the figure.

T_{10} can be determined by the methods illustrated previously in this example for evaluating step-dose tracer test data. The graphical method illustrated on Figure C-3 results in a reading of $T_{10} = 15$ minutes.

TABLE C-4
EVALUATION OF SLUG-DOSE DATA

<u>t. minutes</u>	<u>Fluoride, mg/L</u>	<u>Incremental Area, mg-min/L</u>	<u>Cumulative Area, mg-min/L</u>	<u>Equivalent Step-Dose Data</u>
0	0	0	0	0
3	0	0	0	0
6	0	0	0	0
9	0	0	0	0
12	1	3	3	0.05
15	3.4	10.2	13.2	0.22
18	3.6	10.8	24.0	0.40
21	1.8	5.4	29.4	0.49
24	1.9	5.7	35.1	0.59
27	1.2	3.6	38.7	0.65
30	1.1	3.3	42.0	0.71
33	1.3	3.9	45.9	0.77
36	0.8	2.4	48.3	0.81
39	0.4	1.2	49.5	0.83
42	0.8	2.4	51.9	0.87
45	0.4	1.2	53.1	0.89
48	0.6	1.8	54.9	0.92
51	0.4	1.2	56.1	0.94
54	0.2	0.6	56.7	0.95
57	0.3	0.9	57.6	0.97
60	0.4	1.2	58.8	0.99
63	0.2	+ 0.6	59.4	1.00

Total Area = 59.4

C.1.7.3 Additional Considerations

In addition to determining T_{10} for use in CT calculations, slug-dose tracer tests provide a more general measure of the basin's hydraulics in terms of the fraction of tracer recovery. This number is representative of short-circuiting and dead space in the unit resulting from poor baffling conditions and density currents induced by the tracer chemical. A low tracer recovery is generally indicative of inadequate hydraulics. However, inadequate sampling in which peaks in tracer passage are not measured will result in an under estimate of tracer recovery. The tracer recovery is calculated by dividing the mass of fluoride detected by the mass of fluoride dosed.

The dosed fluoride mass was calculated previously and was 434 grams. The mass of detected fluoride can be calculated by multiplying the total area under the slug-dose curve by the average flow, in appropriate units, at the time of the test. The average flow in the clearwell during the test was 2.5 mgd or 6,570 L/min. Therefore, the mass of fluoride tracer that was detected is calculated as follows:

$$\begin{aligned}\text{Detected fluoride mass} &= \text{total area} \times \text{average flow} \\ &= 59.4 \frac{\text{mg-min}}{\text{L}} \times \frac{1 \text{ g}}{1000 \text{ mg}} \times 6,570 \frac{\text{L}}{\text{min}} \\ &= 390 \text{ g}\end{aligned}$$

Tracer recovery is then calculated as follows:

$$\begin{aligned}\text{Fluoride recovery} &= \text{detected mass/dosed mass} \times 100 \\ &= 390 \text{ g} / 434 \text{ g} \times 100 \\ &= 90 \%\end{aligned}$$

This is a typical tracer recovery percentage for a slug-dose test, based on the experiences of Hudson (1975) and Thirumurthi (1969).

C.1.8 Flow Dependency of T_{10}

For systems conducting tracer studies at four or more flows, the T_{10} detention time should be determined by the above procedures for each of the desired flows. The detention times should then be plotted versus flow. For the example presented in the previous section, tracer studies

were conducted at additional flows of 1.1, 4.2, and 5.6 MGD. The T_{10} values at the various flows were:

<u>Flow</u>	<u>T_{10}</u>
1.1	25
2.5	13
4.2	7
5.6	4

T_{10} data for these tracer studies were plotted as a function of the flow, Q , as shown on Figure C-4.

If only one tracer test is performed, the flow rate for the tracer study should be not less than 91 percent of the highest flow rate experienced for the section. The hydraulic profile to be used for calculating CT would then be generated by drawing a line through points obtained by multiplying the T_{10} at the tested flow rate by the ratio of the tracer study flow rate to each of several different flows in the desired flow range.

For the example presented in the previous section, the clearwell experiences a maximum flow at peak hourly conditions of 6.0 mgd. The highest tested flow rate was 5.6 mgd, or 93 percent of the maximum flow. Therefore, the detention time, $T_{10} = 4$ minutes, determined by the tracer test at a flow rate of 5.6 mgd may be used to provide a conservative estimate of T_{10} for all flow rates less than or equal to the maximum flow rate, 6.0 mgd. The line drawn through points found by multiplying $T_{10} = 4$ minutes by the ratio of 5.6 mgd to each of several flows less than 5.6 mgd is also shown on Figure C-4 for comparative purposes with the hydraulic profile obtained from performing four tracer studies at different flow rates.

C.2 Determination of T_{10} Without Conducting a Tracer Study

In some situations, conducting tracer studies for determining the disinfectant contact time, T_{10} , may be impractical or prohibitively expensive. The limitations may include a lack of funds, manpower or equipment necessary to conduct the study. For these cases, the Primacy Agency may allow the use of "rule of thumb" fractions representing the

FIGURE C-4
Detention Time vs. Flow

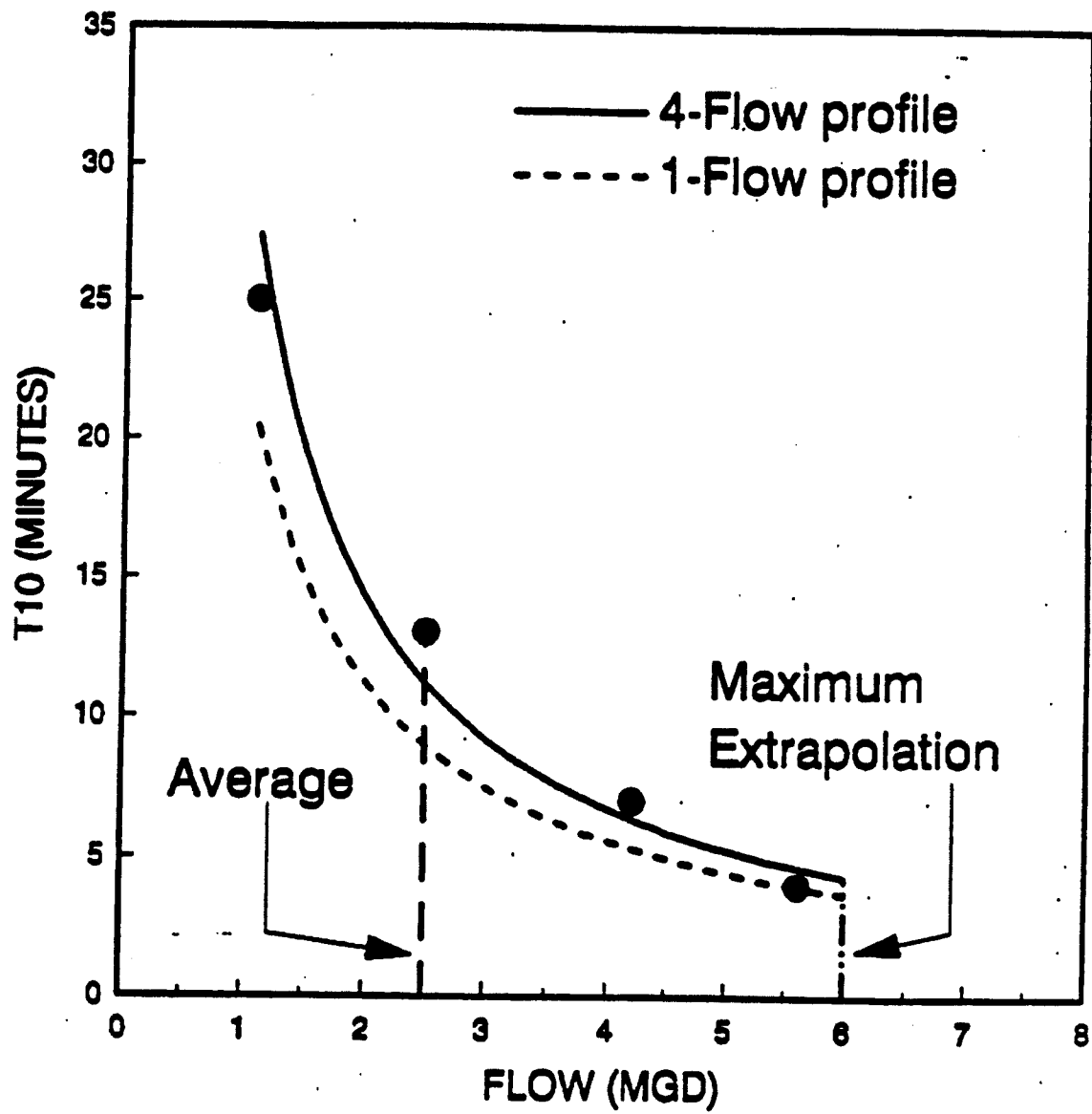

ratio of T_{10} to T , and the theoretical detention time, to determine the detention time, T_{10} , to be used for calculating CT values. This method for finding T_{10} involves multiplying the theoretical detention time by the rule of thumb fraction, T_{10}/T , that is representative of the particular basin configuration for which T_{10} is desired. These fractions provide rough estimates of the actual T_{10} and are recommended to be used only on a limited basis.

Tracer studies conducted by Marske and Boyle (1973) and Hudson (1975) on chlorine contact chambers and flocculators/settling basins, respectively, were used as a basis in determining representative T_{10}/T values for various basin configurations. Marske and Boyle (1973) performed tracer studies on 15 distinctly different types of full-scale chlorine contact chambers to evaluate design characteristics that affect the actual detention time. Hudson (1975) conducted 16 tracer tests on several flocculation and settling basins at six water treatment plants to identify the effect of flocculator baffling and settling basin inlet and outlet design characteristics on the actual detention time.

C.2.1 Impact of Design Characteristics

The significant design characteristics include: length-to-width ratio, the degree of baffling within the basins, and the effect of inlet baffling and outlet weir configuration. These physical characteristics of the contact basins affect their hydraulic efficiencies in terms of dead space, plug flow, and mixed flow proportions. The dead space zone of a basin is basin volume through which no flow occurs. The remaining volume where flow occurs is comprised of plug flow and mixed flow zones. The plug flow zone is the portion of the remaining volume in which no mixing occurs in the direction of flow. The mixed flow zone is characterized by complete mixing in the flow direction and is the complement to the plug flow zone. All of these zones were identified in the studies for each contact basin. Comparisons were then made between the basin configurations and the observed flow conditions and design characteristics.

The ratio T_{10}/T was calculated from the data presented in the studies and compared to its associated hydraulic flow characteristics. Both studies resulted in T_{10}/T values which ranged from 0.3 to 0.7. The results

of the studies indicate how basin baffling conditions can influence the T_{10}/T ratio, particularly baffling at the inlet and outlet to the basin. As the basin baffling conditions improved, higher T_{10}/T values were observed, with the outlet conditions generally having a greater impact than the inlet conditions.

As discovered from the results of the tracer studies performed by Marske and Boyle (1973) and Hudson (1975), the effectiveness of baffling in achieving a high T_{10}/T fraction is more related to the geometry and baffling of the basin than the function of the basin. For this reason, T_{10}/T values may be defined for three levels of baffling conditions rather than for particular types of contact basins. General guidelines were developed relating the T_{10}/T values from these studies to the respective baffling characteristics. These guidelines can be used to determine the T_{10} values for specific basins.

C.2.2 Baffling Classifications

The purpose of baffling is to maximize utilization of basin volume, increase the plug flow zone in the basin, and minimize short circuiting. Some form of baffling at the inlet and outlet of the basins is used to evenly distribute flow across the basin. Additional baffling may be provided within the interior of the basin (intra-basin) in circumstances requiring a greater degree of flow distribution. Ideal baffling design reduces the inlet and outlet flow velocities, distributes the water as uniformly as practical over the cross section of the basin, minimizes mixing with the water already in the basin, and prevents entering water from short circuiting to the basin outlet as the result of wind or density current effects. Three general classifications of baffling conditions -- poor, average, and superior -- were developed to categorize the results of the tracer studies for use in determining T_{10} from the theoretical detention time of a specific basin. The T_{10}/T fractions associated with each degree of baffling are summarized in Table C-5. Factors representing the ratio between T_{10} and the theoretical detention time for plug flow in pipelines and flow in a completely mixed chamber have been included in Table C-5 for comparative purposes. However, in practice the theoretical T_{10}/T values of 1.0 for plug flow and 0.1 for mixed flow are seldom

TABLE C-5

BAFFLING CLASSIFICATIONS

<u>Baffling Condition</u>	<u>L_0/L</u>	<u>Baffling Description</u>
Unbaffled (mixed flow)	0.1	None, agitated basin, very low length to width ratio, high inlet and outlet flow velocities
Poor	0.3	Single or multiple unbaffled inlets and outlets, no intra-basin baffles
Average	0.5	Baffled inlet <u>or</u> outlet with some intra-basin baffles
Superior	0.7	Perforated inlet baffle, serpentine or perforated intra-basin baffles, outlet weir or perforated launders
Perfect (plug flow)	1.0	Very high length to width ratio (pipeline flow), perforated inlet, outlet, and intra-basin baffles

achieved because of the effect of dead space. Conversely, the T_{10}/T values shown for the intermediate baffling conditions already incorporate the effect of the dead space zone, as well as the plug flow zone, because they were derived empirically rather than from theory.

As indicated in Table C-5, poor baffling conditions consist of an unbaffled inlet and outlet with no intra-basin baffling. Average baffling conditions consist of intra-basin baffling and either a baffled inlet or outlet. Superior baffling conditions consist of at least a baffled inlet and outlet, and possibly some intra-basin baffling to redistribute the flow throughout the basin's cross-section.

The three basic types of basin inlet baffling configurations are: a target-baffled pipe inlet, an overflow weir entrance, and a baffled submerged orifice or port inlet. Typical intra-basin baffling structures include: diffuser (perforated) walls; launders; cross, longitudinal, or maze baffling to cause horizontal or vertical serpentine flow; and longitudinal divider walls, which prevent mixing by increasing the length-to-width ratio of the basin(s). Commonly used baffled outlet structures include free-discharging weirs, such as sharpcrested and V-notch, and submerged ports or weirs. Weirs that do not span the width of the contact basin, such as Cipolletti weirs, should not be considered baffling as their use may substantially increase weir overflow rates and the dead space zone of the basin.

C.2.3 Examples of Baffling

Examples of these levels of baffling conditions for rectangular and circular basins are explained and illustrated in the following section. Typical uses of various forms of baffled and unbaffled inlet and outlet structures are also illustrated.

The plan and section of a rectangular basin with poor baffling conditions, which can be attributed to the unbaffled inlet and outlet pipes, is illustrated on Figure C-5. The flow pattern shown in the plan view indicates straight-through flow with dead space occurring in the regions between the individual pipe inlets and outlets. The section view reveals additional dead space from a vertical perspective in the upper inlet and lower outlet corners of the contact basin. Vertical mixing also occurs as

bottom density currents induce a counter-clockwise flow in the upper water layers.

The inlet flow distribution is markedly improved by the addition of an inlet diffuser wall and intra-basin baffling as shown on Figure C-6. However, only average baffling conditions are achieved for the basin as a whole because of the inadequate outlet structure -- a Cipolletti weir. The width of the weir is short in comparison with the width of the basin. Consequently, dead space exists in the corners of the basin, as shown by the plan view. In addition, the small weir width causes a high weir overflow rate, which results in short circuiting in the center of the basin.

Superior baffling conditions are exemplified by the flow pattern and physical characteristics of the basin shown on Figure C-7. The inlet to the basin consists of submerged, target-baffled ports. This inlet design serves to reduce the velocity of the incoming water and distribute it uniformly throughout the basin's cross-section. The outlet structure is a sharpcrested weir which extends for the entire width of the contact basin. This type of outlet structure will reduce short circuiting and decrease the dead space fraction of the basin, although the overflow weir does create some dead space at the lower corners of the effluent end. These inlet and outlet structures are by themselves sufficient to attain superior baffling conditions; however, maze-type intra-basin baffling was included as an example of how this type of baffling aids in flow redistribution within a contact basin.

The plan and section of a circular basin with poor baffling conditions, which can be attributed to flow short circuiting from the center feed well directly to the effluent trough is shown on Figure C-8. Short circuiting occurs in spite of the outlet weir configuration because the center feed inlet is not baffled. The inlet flow distribution is improved somewhat on Figure C-9 by the addition of an annular ring baffle at the inlet which causes the inlet flow to be distributed throughout a greater portion of the basin's available volume. However, the baffling conditions in this contact basin are only average because the inlet center feed arrangement does not entirely prevent short circuiting through the upper levels of the basin.

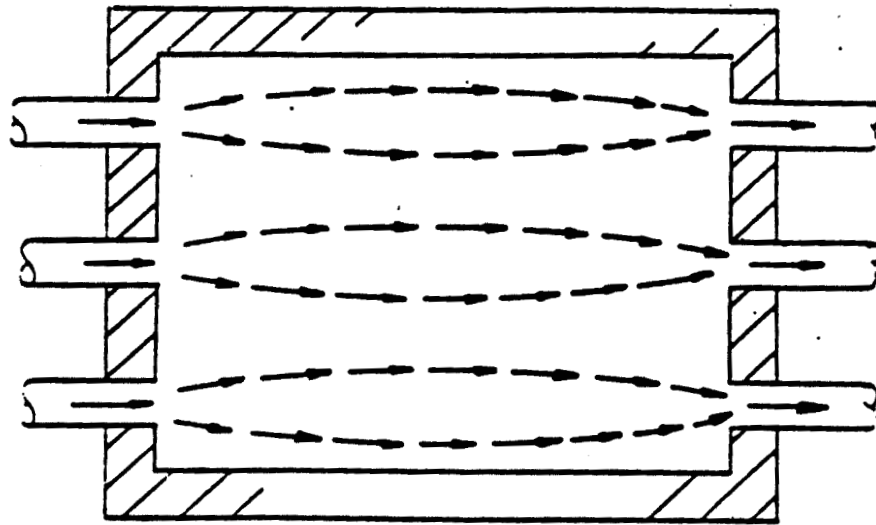

PLAN

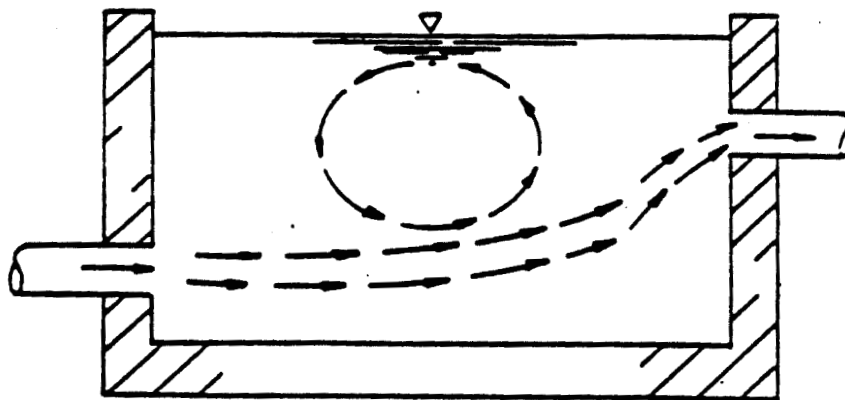

SECTION

FIGURE C-5 POOR BAFFLING CONDITIONS --
RECTANGULAR CONTACT BASIN

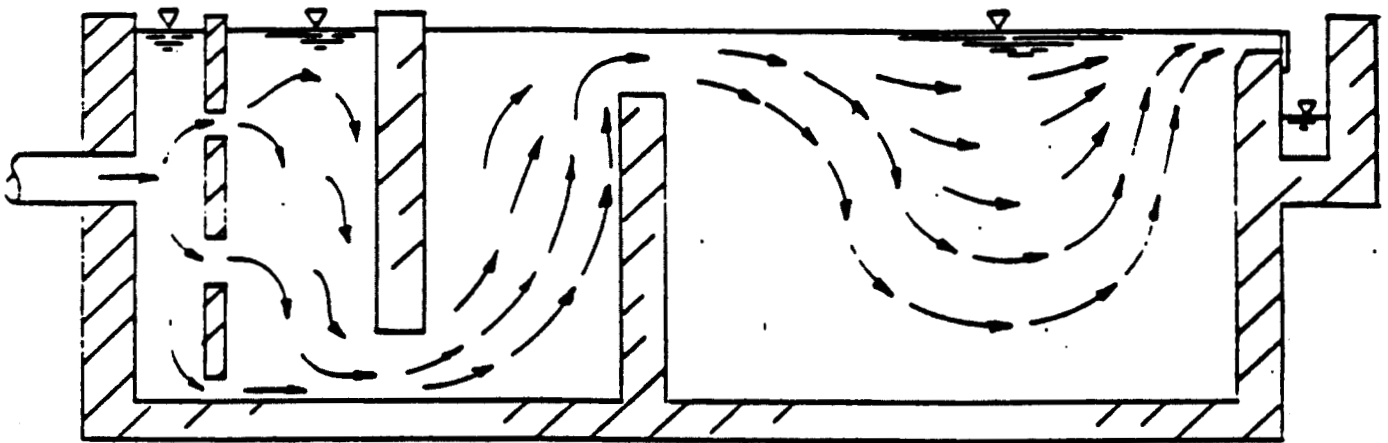
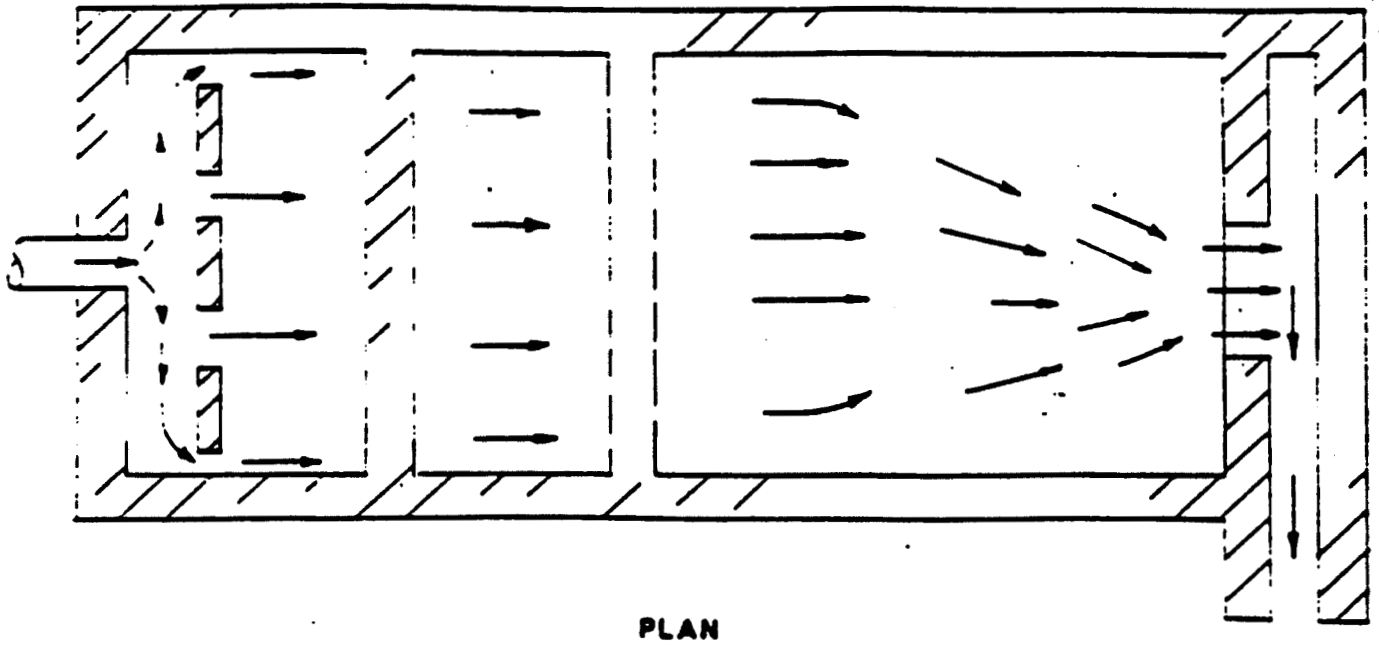

**FIGURE C-6 AVERAGE BAFFLING CONDITIONS --
RECTANGULAR CONTACT BASIN**

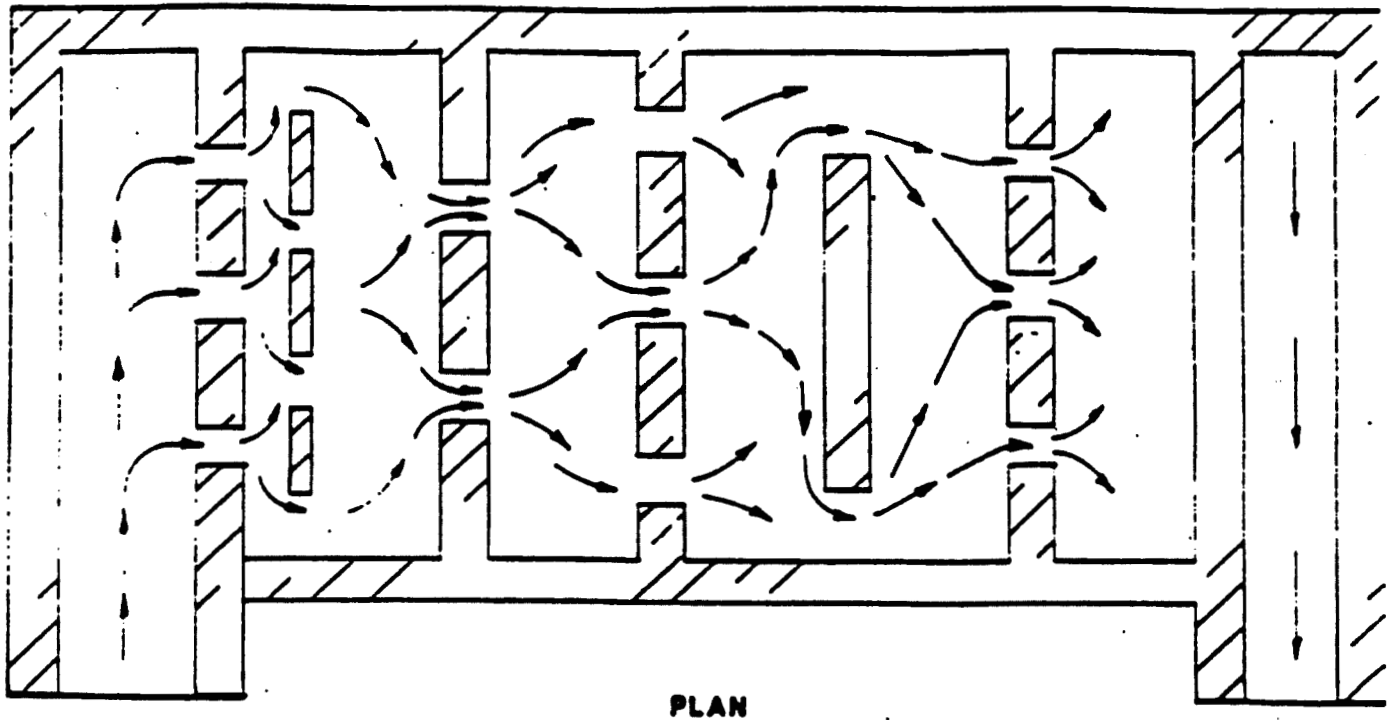

PLAN

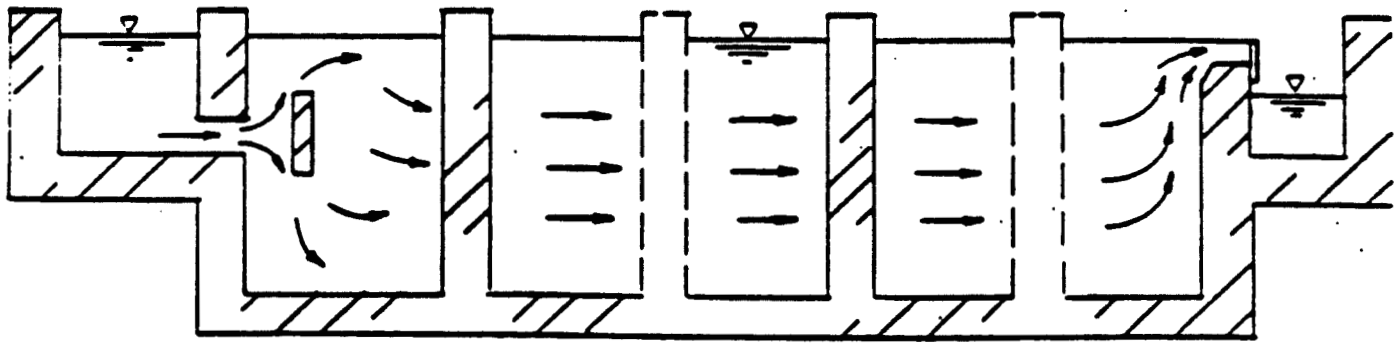

SECTION

**FIGURE C-7 SUPERIOR BAFFLING CONDITIONS --
RECTANGULAR CONTACT BASIN**

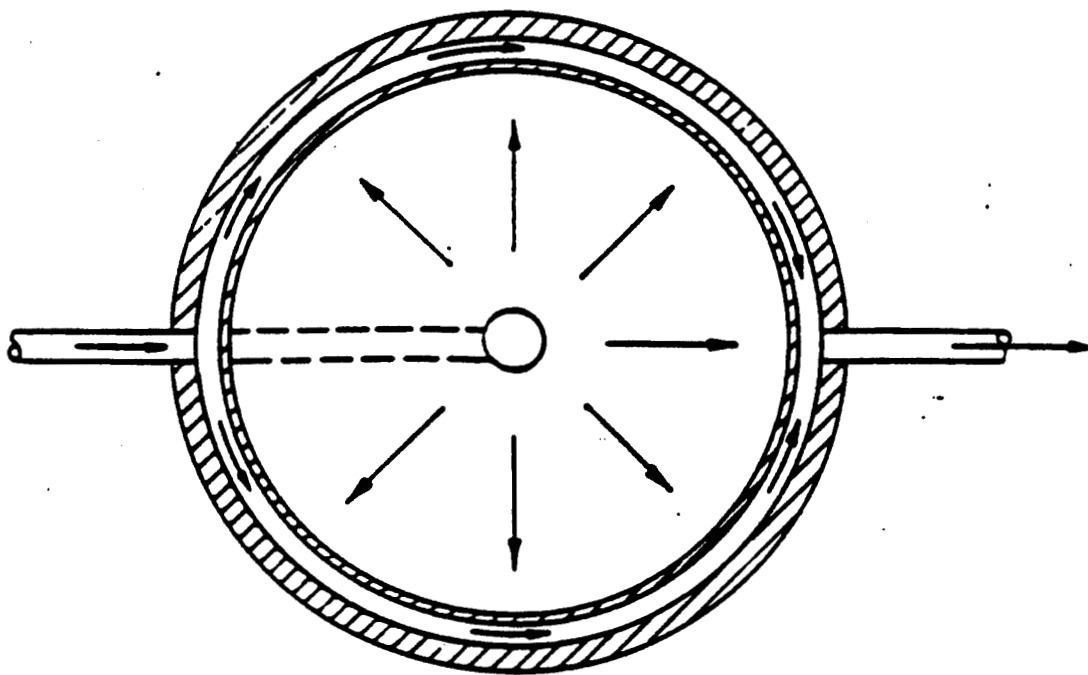

PLAN

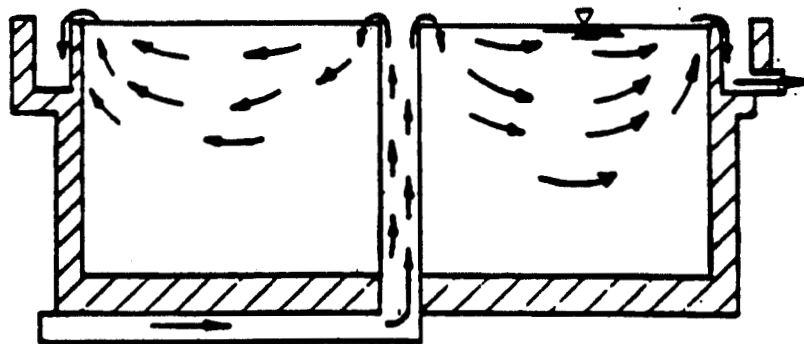

SECTION

FIGURE C-8 POOR BAFFLING CONDITIONS --
CIRCULAR CONTACT BASIN

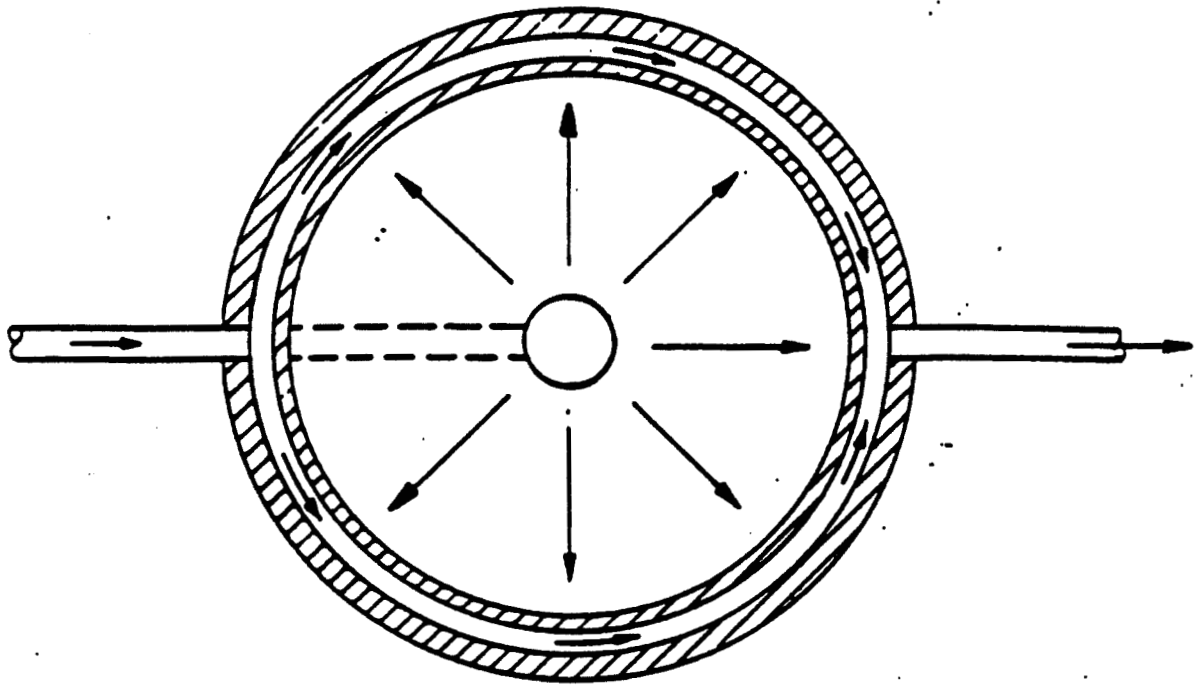

PLAN

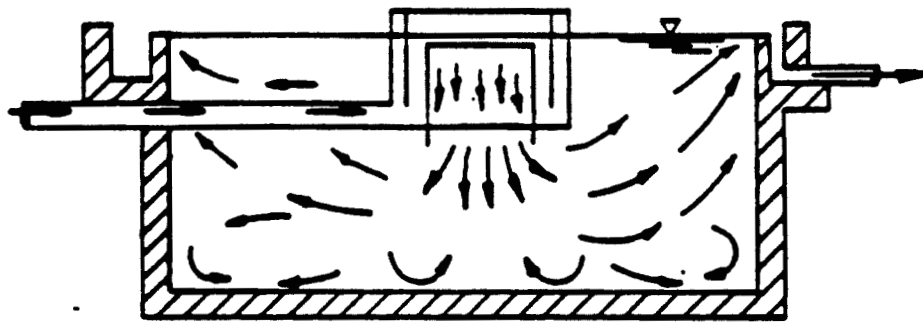

SECTION

FIGURE C-9 AVERAGE BAFFLING CONDITIONS - -
CIRCULAR CONTACT BASIN

Superior baffling conditions are attained in the basin configuration shown on Figure C-10 through the addition of a perforated inlet baffle and submerged orifice outlet ports. As indicated by the flow pattern, more of the basin's volume is utilized due to uniform flow distribution created by the perforated baffle. Short circuiting is also minimized because only a small portion of flow passes directly through the perforated baffle wall from the inlet to the outlet ports.

C.2.4 Additional Considerations

Flocculation basins and ozone contactors represent water treatment processes with slightly different characteristics from those presented in Figures C-5 through C-10 because of the additional effects of mechanical agitation and mixing from ozone addition, respectively. Studies by Hudson (1975) indicated that a single-compartment flocculator had a T_{10}/T value less than 0.3, corresponding to a dead space zone of about 20 percent and a very high mixed flow zone of greater than 90 percent. In this study, two four-compartment flocculators, one with and the other without mechanical agitation, exhibited T_{10}/T values in the range of 0.5 to 0.7. This observation indicates that not only will compartmentation result in higher T_{10}/T values through better flow distribution, but also that the effects of agitation intensity on T_{10}/T are reduced where sufficient baffling exists. Therefore, regardless of the extent of agitation, baffled flocculation basins with two or more compartments should be considered to possess average baffling conditions ($T_{10}/T = 0.5$), whereas unbaffled, single-compartment flocculation basins are characteristic of poor baffling conditions ($T_{10}/T = 0.3$).

Similarly, multiple stage ozone contactors are baffled contact basins which show characteristics of average baffling conditions. Single stage ozone contactors should be considered as being poorly baffled. However, circular, turbine ozone contactors may exhibit flow distribution characteristics which approach those of completely mixed basins, with a T_{10}/T of 0.1, as a result of the intense mixing.

In many cases, settling basins are directly connected to the flocculators. Data from Hudson (1975) indicates that poor baffling conditions at the flocculator/settling basin interface can result in

backmixing from the settling basin to the flocculator. Therefore, settling basins that have integrated flocculators without effective inlet baffling should be considered as poorly baffled, with a T_{10}/T of 0.3, regardless of the outlet conditions, unless intra-basin baffling is employed to redistribute flow. If intra-basin and outlet baffling is utilized, then the baffling conditions should be considered average with a T_{10}/T of 0.5.

Filters are special treatment units because their design and function is dependent on flow distribution that is completely uniform. Except for a small portion of flow which shortcircuits the filter media by channeling along the walls of the filter, filter media baffling provides a high percentage of flow uniformity and can be considered superior baffling conditions for the purpose of determining T_{10} . As such, the T_0 value can be obtained by subtracting the volume of the filter media, support gravel, and underdrains from the total volume and calculating the theoretical detention time by dividing this volume by the flow through the filter. The theoretical detention time is then multiplied by a factor of 0.7, corresponding to superior baffling conditions, to determine the T_{10} value.

C.2.5 Conclusions

The recommended T_{10}/T values and examples are presented as a guideline for use by the Primacy Agency in determining T_{10} values in site specific conditions and when tracer studies cannot be performed because of practical considerations. Selection of T_{10}/T values in the absence of tracer studies was restricted to a qualitative assessment based on currently available data for the relationship between basin baffling conditions and their associated T_{10}/T values. Conditions which are combinations or variations of the above examples may exist and warrant the use of intermediate T_{10}/T values such as 0.4 or 0.6. As more data on tracer studies become available, specifically correlations between other physical characteristics of basins and the flow distribution efficiency parameters, further refinements to the T_{10}/T fractions and definitions of baffling conditions may be appropriate.

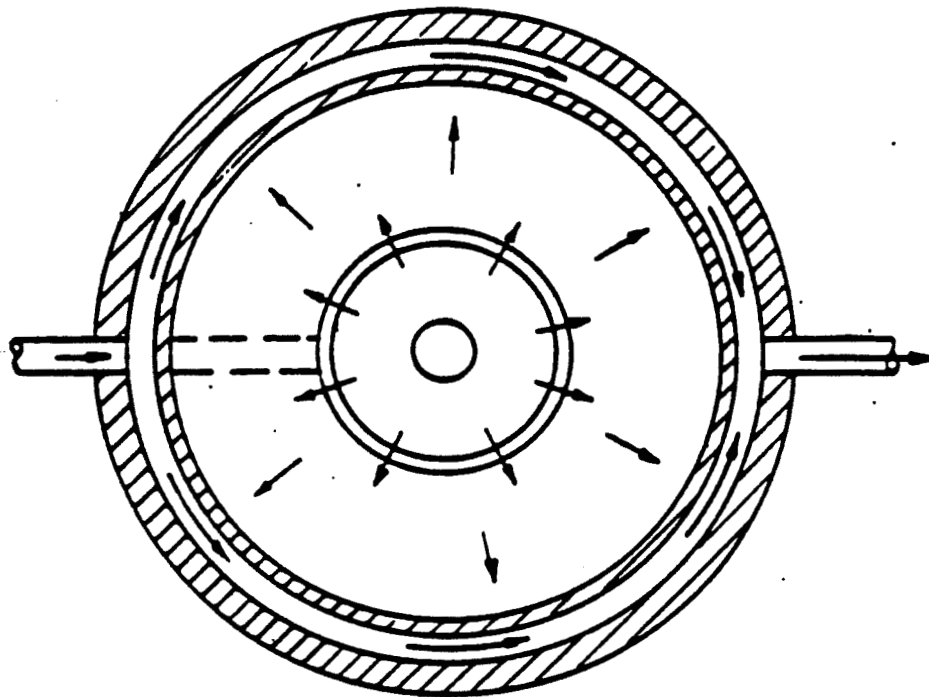

PLAN

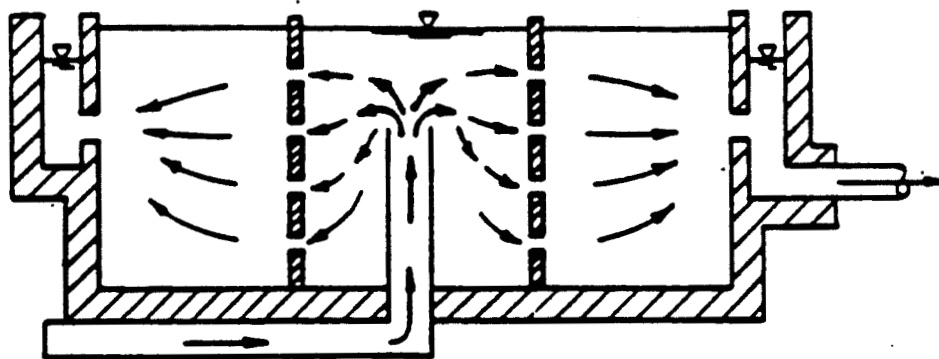

SECTION

FIGURE C-10 SUPERIOR BAFFLING CONDITIONS --
CIRCULAR CONTACT BASIN

References

Hudson, H. E., Jr.. "Residence Times in Pretreatment", J. AWWA, pp. 45-52, January, 1975.

Hudson, H. E., Jr.. Water Clarification Processes: Practical Design and Evaluation, Van Nostrand Reinhold Company, New York, 1981.

Levenspiel, O.. Chemical Reaction Engineering, John Wiley & Sons, New York, 1972.

Marske, D. M. and Boyle, J. D.. "Chlorine Contact Chamber Design - A Field Evaluation", Water and Sewage Works, pp. 70-77, January, 1973.

Thirumurthi, D.. "A Break-through in the Tracer Studies of Sedimentation Tanks", J. WPCF, pp. R405-R418, November, 1969.

APPENDIX C:

CONCENTRATING, PROCESSING, DETECTING AND IDENTIFYING
GIARDIA CYSTS IN WATER

The following pages contain background information supporting Jay Vasconcelos' talk, "Methods of Testing for Giardia in Water." Please see the summary of this talk (pp.14 through 16) for further information, and for an outline of the modified EPA Consensus Method.

APPENDIX C : CONCENTRATING, PROCESSING
 DETECTING AND IDENTIFYING GIARDIA CYSTS IN WATER

<u>METHOD</u>	<u>INVESTIGATOR (S)</u>	<u>RESULTS</u>
1. <u>Membrane Filtration</u>		
Cellulosic (47mm-0.45µm)	Chang and Kabler USPHS, 1956	Generally unsuccessful
Polycarbonate (29.7mm-5µm)	Pyper, DuFrain and Henry Eng 1982, (unpublished)	Passing 1 gal/min at 10-PSI. 15-1800 gal total
2. <u>Particulate Filtration</u> (diatomaceous earth, sand, etc.)	Shaw et al, 1977 Juranek, 1979	Generally good removal but poor elution
3. <u>Algae (Foerst) Centrifuge</u>	Holman et al, 1983 DHHS, Washington	Good rapid recovery, but limited in field use
4. <u>Anionic and Cationic Exchange Resins</u>	Brewer, Wright State UN. (unpublished)	Generally unsuccessful
5. <u>Epoxy-Fiberglass Balston Tube Filters</u> (10"-8µm)	Riggs, CDHS Lab, Berkley, CA (unpublished)	Overall recovery 20-80 percent.
6. <u>Microporous Yarnwoven Depth Filters</u> (7 and 1µm orlon and polypropylene)	Jakubowski, Erickson, 1979 and 1980, EPA-Cincinnati	Recovery 3-15 percent Extraction ave. 58 percent
7. <u>Pellican Cassette System</u>	Millipore Corp. (unpublished)	May be useful for processing filter washings
8. <u>Filterwashing Apparatus</u>	DuWalle, U. of Wash., 1982 (unpublished)	Claims 75 percent recovery from orlon filters

TABLE 1

APPENDIX C: CONCENTRATING, PROCESSING,
DETECTING AND IDENTIFYING GIARDIA CYSTS IN WATER

PRIMARY CONCENTRATION AND PROCESSING METHODS

1. MEMBRANE FILTER (MF) METHODS

a. Cellulosic (mixed esters of cellulose)

1. Chang and Kabler in 1955
First to use MF for cyst recovery. Recovered 20-42 percent at cyst concentration of 3, 5, and 10 cyst/gal. - no cyst found at 1 cyst/gal.
2. Method was used in 1965 Colorado outbreak (Moore, et al, 1969) using 2 liter size water samples from 10 sites. No cysts were detected. Use of cellulosic filters have generally not been successful in demonstrating cysts in drinking water.

b. Polycarbonate (PC) Filters

1. Luchtel and Colleagues in 1980 used 293 mm, 5.0 μ m pore size nucleopore (PC) filters to concentrate formalin-fixed G. lamblia cysts from 20 L tap water samples. Recovery rates of approximately 75 percent were reported.
2. Pyper of DuFrain and Henry Engineers claim good recovery with same nucleopore filter at a flow rate of 1 gal./min., not over 10 PSI, passing 15-1800 gal. in just over 24 hours.

c. Even with these claims by Pyper and Luchtel, the MF Method has only once (Aspen, 1965) been successful in demonstrating cysts in water--probably because:

1. Inability to process a sufficient volume.
2. Inability to remove cysts from filter.
3. Cysts weren't present at time of sampling during or after outbreak.

2. PARTICULATE FILTRATION

- a. SAND - CDC (Shaw, 1977) used high-vol filtration through swimming pool sand filter (280,000 gal. total over 10 days) - was backflushed into 55 gal. drums and coagulated w/alum. Concentration fed to beagle puppies and after treatment (cheesecloth to wire screening to 30 μ m MF to centrifuge) was examined microscopically. First time cysts observed in water supply after concentration.
- b. Diatomaceous earth (DE) - CDC (Juraneck, 1979) used DE to remove cysts from seeded water. Problem was that cysts couldn't be removed from DE particles. Brewer (1983) claims 5.2-31.1 percent recovery from DE backwash. Retention through 3 forms (celite 505, HyFlo-Supercel and celite 560) at cyst concentration ranging from 6-15,000 cyst/L. Recovery range between 66-100 percent.

APPENDIX C: CONCENTRATING, PROCESSING,
DETECTING AND IDENTIFYING GIARDIA CYSTS IN WATER

3. ALGAE CENTRIFUGE

- a. Was found to recover more cysts (10X) than a series of MF-filters and nylon screens: 5 vs. 1 day by MF.
- b. May be impractical in field because of power requirement.
- c. If used in lab, 1 large single sample collected in the field could miss cyst.
- d. May find application for concentration cysts from orlon filter washings.

4. ANIONIC AND CATIONIC EXCHANGE RESINS (Brewer - unpublished)

- a. Based on hypothesis that cysts could be attracted to charged surfaces, cysts have a charge of approximately 25mV at pH 5.5 which increases in electro-negativity as the pH rises to 8.0.
- b. Charge attraction techniques have been used for concentration of both bacteria and viruses in water.
- c. Five exchange resins were tested:
 - (1. 40 percent recovery from anionic Dowex 1-XY columns
 - (2. 38 percent recovery from cationic Dowex 50W-X8 columns
- d. Compared to parallel tests w/diatomaceous earth, exchange resins less efficient in retention.

5. BALSTON EPOXY-FIBERGLASS TUBE FILTERS

- a. Riggs of CSHD, Viral and Rick. Lab., can filter 500 gallons drinking water thru 10" - 8 μ m Balston tube filter.
- b. Backflushes w/1 L 3 percent beef extract or solution of 0.5 percent potassium citrate.
- c. Concentration is centrifuged w/40 percent potassium citrate and middle layer filtered thru 5 μ polycarbonate filters.
- d. Uses direct immunofluorescence antibody technique for detection and identification.
- e. Claims 20-80 percent efficiency in collection, preprocessing and ID.

6. MICROPOROUS YARNWOVEN DEPTH FILTERS

- a. In 1975 EPA developed a concentration-extraction method involving large volumes of water thru microporous yarnwoven orlon-fiber filters.
- b. This method has been tentatively adopted as the "method of choice" for concentrating cysts from water supplies.

APPENDIX C: CONCENTRATING, PROCESSING,
DETECTING AND IDENTIFYING GIARDIA CYSTS IN WATER

- c. Since initial studies which showed only 3-15 percent recovery with a mean of 6.3 percent and a 58 percent extraction rate, several changes have been made which may have increased the retention rate to >20 percent.
 - 1. Gone from 7 to 1 μ m porosity filter
 - 2. Limited the rate of flow to 1/2 gallon/min
 - 3. Limited the pressure head to 10 PSI
 - 4. Have gone to polypropylene filters in lieu of orlon
- d. It was the first method successfully used to detect cysts in the distribution system of a community water supply.
- e. Is the recommended filter to be used by the EPA consensus method.

7. PELLICAN CASSETTE SYSTEM

- a. Is a plate and frame style holder which accepts both ultra thin and depth type filters.
- b. Has from 0.5 to 25 ft² of filter area.
- c. Has not been investigated thoroughly but has had some success in virus concentration.
- d. Its main application for cyst recovery may lay with the processing of filter washings.

8. FILTERWASHING APPARATUS

- a. This is a proposed device by DuWalle, 1982 from U. of W., for unwinding the fibers from the filter cartridge while repeatedly brushing and squeezing them while in a bath solution.
- b. Bath could contain either a surfactant or pH controlled solution.
- c. Potential claims are as high as 75 percent extraction of cysts from the fibers.

TABLE 2: DETECTION METHODS

<u>METHOD</u>	<u>INVESTIGATOR(S)</u>	<u>RESULTS</u>
1. <u>Immunofluorescence</u>	Riggs, CSDHS Lab, Berkley, CA 1983	Good prep., Cross Rx
a. DFA		
b. IFA	Sauch, EPA-Cincinnati Riggs, CSDS	Still under study
c. Monoclonal Antibodies	Riggs, CSDHS Sauch, EPA-Cincinnati (unpublished)	Still under study
2. <u>ELISA Method</u>	Hungar, J. Hopkins MD, 1983	Feces samples only
3. <u>Brightfield/Phase Contrast</u>	EPA Consensus method	Ongoing

APPENDIX C: CONCENTRATING, PROCESSING,
DETECTING AND IDENTIFYING GIARDIA CYSTS IN WATER

DETECTION METHODS

1.a. DIRECT FLUORESCENT ANTIBODY (DRA) TECHNIQUE

1. Riggs has produced a high titer purified immune sera to Giardia lamblia cysts in guinea pigs and labeled it with Fluorecein isothio cyanate. Sera is purified thru NH₄OH and DEAE sefadex fractionation.
2. Obtained cross reactions with Chilomastix mesnili cysts but claims it can be easily distinguished from Giardia by its smaller size.

1.b. INDIRECT FLUORESCENT ANTIBODY (IFA) TECHNIQUE

1. Sauch using IFA with immune sera from rabbits (unpurified). It is reacted with commercially available fluorescent-labeled goat anti-rabbit gamma globulin.
2. Some cross-reactions with certain algal cells.

1.c. MONOCLONAL ANTIBODIES

1. Using clones of hybridoma cell lines obtained by fusing mouse myeloma cells with spleen cells from mice (BALB/c) immunized with G. lamblia trophozoites.
2. Produced eight monoclonal antibodies evaluated by IFA against both trophs and cysts.
 - a. 3/8 stained the ventral disk
 - b. 2 stained the nuclei
 - c. 2 stained cytoplasmic granules
 - d. 2 stained membrane components.
3. Variability in staining may be due to differences in stages of encystment.
4. Preliminary results indicate monoclonal ABs may give rapid and specific ID of cysts.
5. Rx may be too specific, not reacting with all human forms of G. lamblia may have to go to polyclonal ABs.

2. ELISA METHOD

- a. Hungar at John Hopkins (unpublished) has produced a detection method by ELISA using a intact "sandwich" technique in 96-well microtiter plates.
- b. Using antisera from 2 different animals (may present problem).
- c. Need a minimum of 12 cysts/well for color Rx.

APPENDIX D

**ANALYTICAL REQUIREMENTS OF THE SWTR AND
A SURVEY OF THE CURRENT STATUS OF RESIDUAL DISINFECTANT
MEASUREMENT METHODS FOR ALL CHLORINE SPECIES AND OZONE**

APPENDIX D
ANALYTICAL REQUIREMENTS

Only the analytical method(s) specified in the SWTR, or otherwise approved by EPA, may be used to demonstrate compliance with the requirements of the SWTR. Measurements of pH, temperature, turbidity, and residual disinfectant concentrations must be conducted by a party approved by the Primacy Agency. Measurements for total coliforms, fecal coliforms, and heterotrophic bacteria as measured by the heterotrophic plate count (HPC), must be conducted by a laboratory certified by the Primacy Agency or EPA to do such analysis. Until laboratory certification criteria are developed for the analysis of HPC and fecal coliforms, any laboratory certified for total coliform analysis is acceptable for HPC and fecal coliform analysis. The test methods to be used for various analyses are listed below:

- (1) Fecal coliform concentration - Method 908C (MPN Procedure), 908D (Estimation of Bacterial Density), or 909C (Membrane Filter Procedure) as set forth in Standard Methods for the Examination of Water and Wastewater, American Public Health Association, 16th edition.
- (2) Total coliform concentration - Methods 908A, B, D (MPN Procedure) or 909A, B (Membrane Filter Procedure) as set forth in Standard Methods for the Examination of Water and Wastewater, American Public Health Association, 16th edition; Autoanalysis Colilert (EPA refers to this as Minimal Medium ONPG-MUG Method), as set forth in Applied and Environmental Microbiology, American Society for Microbiology, Volume 54, No. 6, June 1988. pp. 1595-1601.
- (3) Heterotrophic Plate Count - Method 907A (Pour Plate Method), as set forth in Standard Methods for the Examination of Water and Wastewater, American Public Health Association, 16th edition.
- (4) Turbidity - Method 214A (Nephelometric Method) as set forth in Standard Methods for the Examination of Water and Wastewater, American Public Health Association, 16th edition.
- (5) Residual disinfectant concentration - Residual disinfectant concentrations for free chlorine and combined chlorine must be measured by Method 408C (Amperometric Titration Method), Method 408D (DPD Ferrous Titrimetric Method), Method 408E (DPD Colorimetric Method), or Method 408F (Leuco Crystal Violet

Method) as set forth in Standard Methods for the Examination of Water and Wastewater, American Public Health Association, 16th edition. Disinfectant residuals for free chlorine and combined chlorine may also be measured by using DPD colorimetric test kits if approved by the Primacy Agency. Disinfectant residuals for ozone must be measured by the Indigo Trisulfonate Method (Bader, H., Hoigne, J., "Determination of Ozone in Water by the Indigo Method; A Submitted Standard Method;" Ozone Science and Engineering, Vol. 4, pp. 169-176, Pergamon Press Ltd., 1982), or automated methods which are calibrated in reference to the results obtained by the Indigo Trisulfonate Method, on-a regular basis, as determined by the Primacy Agency. This method is described in section of the manual. (Note: This method is included in the 17th edition of Standard Methods for the Examination of Water and Wastewater, American Public Health Association; the Iodometric Method in the 16th edition may not be used.) Disinfectant residuals for chlorine dioxide must be measured by Method 410B (Amperometric Method) or Method 410C (DPD Method) as set forth in Standard Methods for the Examination of Water and Wastewater, American Public Health Association, 16th edition.

- (6) Temperature - Method 212 as set forth in Standard Methods for the Examination of Water and Wastewater, American Public Health Association, 16th edition.
- (7) pH - Method 423 as set forth in Standard Methods for the Examination of Water and Wastewater, American Public Health Association, 16th edition.

References

Edberg et al, "National Field Evaluation of a Defined Substrate Method for the Simultaneous Enumeration of Total Coliforms and Escherichia Coli from Drinking Water: Comparison with the Standard Multiple Tube Fermentation Method," Applied and Environmental Microbiology, Volume 54, pp. 1595-1601, June 1988.

PREFACE

The AWWA paper entitled "A survey of the current status of residual disinfectant measurement method for all chlorine species and ozone" will be included in the final document. It has not been included here for the sake of brevity. However, the publication is available from the AWWA Customer Services Department, 6666 W. Quincy Avenue, Denver, Co. 80235; Telephone (303) 794-7711. The document publication number is 90529.

The above publication summarizes the AWWA Research foundation's 816 page publication entitled " Disinfectant Residual Measurement Methods", publication number 90528. This document is also available from the customer services department listed above.

**A SURVEY OF THE CURRENT STATUS OF RESIDUAL DISINFECTANT
MEASUREMENT METHODS FOR ALL CHLORINE SPECIES AND OZONE**

by

Gilbert Gordon
Department of Chemistry
Miami University
Oxford, OH 45056

William J. Cooper
Drinking Water Research Center
Florida International University
Miami, Florida 33199

Rip G. Rice
Rice, Incorporated
Ashton, Maryland 20861

Gilbert E. Pacey
Department of Chemistry
Miami University
Oxford, Ohio 45056

Prepared for:

AWWA Research Foundation
6665 W. Quincy Avenue
Denver, CO 80235

November 1987

Published by the American Water Works Association

DISCLAIMER

This study was funded by the American Water Works Association Research Foundation (AWWARF). AWWARF assumes no responsibility for the content of the research study reported in this publication, or for the opinions or statements of fact expressed in the report. The mention of tradenames for commercial products does not represent or imply the approval or endorsement of AWWARF. This report is presented solely for informational purposes.

Although the research described in this document has been funded in part by the United States Environmental Protection Agency through a Cooperative Agreement, CR-811335-01, to AWWARF, it has not been subjected to Agency review and therefore does not necessarily reflect the views of the Agency and no official endorsement should be inferred.

Copyright © 1987
by
American Water Works Association Research Foundation
Printed in U.S.

FOREWORD

This report is part of the on-going research program of the AWWA Research Foundation. The research described in the following pages was funded by the Foundation in behalf of its members and subscribers in particular and the water supply industry in general. Selected for funding by AWWARF's Board of Trustees, the project was identified as a practical, priority need of the industry. It is hoped that this publication will receive wide and serious attention and that its findings, conclusions, and recommendations will be applied in communities throughout the United States and Canada.

The Research Foundation was created by the water supply industry as its center for cooperative research and development. The Foundation itself does not conduct research; it functions as a planning and management agency, awarding contracts to other institutions, such as water utilities, universities, engineering firms, and other organizations. The scientific and technical expertise of the staff is further enhanced by industry volunteers who serve on Project Advisory Committees and on other standing committees and councils. -An extensive planning process involves many hundreds of water professionals in the important task of keeping the Foundation's program responsive to the practical, operational needs of local utilities and to the general research and development needs of a progressive industry.

All aspects of water supply are served by AWWARF's research agenda: resources, treatment and operations, distribution and storage, water quality and analysis, economics and management. The ultimate purpose of this effort is to assist local water suppliers to provide the highest possible quality of water, economically and reliably. The Foundation's Trustees are pleased to offer this publication as contribution toward that end.

This project reviewed all disinfectant residual measurement methods for free chlorine, chloramines, ozone and chlorine dioxide with special attention to interferences that could be experienced by the water utility industry. Recommendations, practical guidance, and cautions on the selection of appropriate residual measurement techniques are summarized (Please see Preface for information on full report).



Jerome B. Gilbert
Chairman, Board of Trustees
AWWA Research Foundation



James F. Hanwaring, P.E.
Executive Director
AWWA Research Foundation

PREFACE

This document summarizes the AWWA Research Foundation's 815 page publication "Disinfectant Residual Measurement Methods." That publication (Publication Number 90529) can be ordered from the AWWA Customer Services Department, 6666 W. Quincy Avenue, Denver, CO 80235; telephone, (303) 794-7711.

The purpose of this summary document is to provide the water utility laboratory analyst with guidance in selecting disinfectant residual measurement methods. Either this document or the full report is recommended as a companion to Standard Methods for the Examination of Water and Wastewater.

ACKNOWLEDGEMENTS

The authors wish to express their appreciation to the American Water Works Association - Research Foundation for the opportunity to carry out this detailed review of the literature.

Furthermore, the authors would like to pay tribute to the really important people -- all those who did the original work and made this secondary source of information possible.

Finally, the authors wish to express their appreciation to the members of the Project Advisory Committee:

- 1) Mark Carter, Ph.D.
Rocky Mountain Analytical Laboratories
- 2) J. Donald Johnson, Ph.D.
University of North Carolina
- 3) Leown A. Moore
Drinking Water Research Division--EPA
- 4) R. Rhodes Trussell, Ph.D.
James M. Montgomery Consulting Engineers, Inc.

G.G.

W.J.C.

R.G.R

G.E.P.

EXECUTIVE SUMMARY

BACKGROUND

The objective of this Report is to review and summarize all disinfectant residual measurement techniques currently available for free chlorine (along with the various chloramines), combined chlorine, chlorite ion, chlorine dioxide, chlorate ion, and ozone.

Presently, both chlorine dioxide and ozone are gaining considerable favor as alternatives to chlorine disinfection (1). The analytical chemistry for these disinfectants when compared with chlorine is even more complex and less readily understood as evidenced by various surveys (2-5) and detailed research carried out in various laboratories (6-10).

Chlorine dioxide is manufactured at the site of its use by reactions involving sodium chlorite, chlorate ion, chlorine gas and/or hypochlorite ion and sulfuric acid or hydrochloric acid (11-12). Consequently, chlorate ion, chlorite ion, hypochlorite ion and/or hypochlorous acid frequently will be found occurring as by-products or unreacted starting materials. These materials are strong oxidizing agents which are very reactive and behave in many ways similar to chlorine dioxide itself.

There are more than 2,000 water treatment plants today using ozone, and less than half of them are applying ozone solely for disinfection. The large majority of water treatment plants use ozone as a chemical oxidant. Many of the plants applying ozone for disinfection also are using ozone, in the same plant, for chemical oxidation. Analyses for residual ozone in water are applicable only in the treatment plant, either in the ozone contactor(s) or at their outlets. Residual ozone is never present in the distribution system; however, its by-products may be.

There have been numerous attempts to evaluate the relative advantages and disadvantages associated with the measurement of free and combined chlorine. Different criteria are frequently used for the evaluation of the analytical measurements and often suggestions for the improvement of test procedures have gone largely ignored. No comprehensive and objective review of the literature appears to be available. This Report is aimed at providing such a review along with guidance and recommendations as to what criteria water utilities should use in selecting residual monitoring techniques based on circumstances by category.

OBJECTIVES

1. To review and summarize all residual measurement techniques currently available for free chlorines--taking into account the roles of chloramines.
2. To review and summarize all residual measurement techniques currently available for combined chlorine.

3. To briefly review the present understanding of the chlorine-ammonia chemistry and in particular, in relationship to the measurement of chlorine and combined chlorine.
4. To review and summarize all residual measurement techniques currently available for chlorine dioxide, chlorite ion and chlorate ion.
5. To review and summarize the analytical procedures currently used by operating water utilities to control ozone treatment processes, considering disinfection as well as the many oxidative applications of ozone in water treatment applications.
6. To discuss common interferences associated with the measurement of each of the disinfectants/oxidants described above (free chlorine, combined chlorine, chlorite ion, chlorine dioxide, chlorate ion, and ozone).
7. To provide guidance and recommendation for water utilities in selecting residual monitoring techniques for each of the above disinfectants/oxidants.
8. To recommend future research for development of monitoring and analytical methods to improve accuracy, and reduce time and cost requirements for the measurement of the above disinfectants.

In the full report, we present as complete as possible an examination of the world-wide body of literature on analytical methods used by the water utility industry in order to elaborate on the various problems, advantages, disadvantages and known interferences for each of the currently used analytical methods.

Foremost in our objectives has been a better understanding of the reliability of various measurements which have been carried out. Since there are inherent limitations in all measurements, it becomes apparent that there are specific needs for some indication of the reliability of the result, i.e., what is the precision and accuracy of the reported value, and are these acceptable?

The volatility of most of the disinfectants makes sampling and sample handling a major contributor to imprecision and inaccuracies. "Standard additions" is a questionable technique; it should be avoided if possible, since the pipetting and dilution process causes potential loss of disinfectant.

The relative usefulness of each method, along with descriptions of known interferences such as turbidity, organic matter, ionic materials, solids, color, buffering capacity, as well as the nature of the sample and the time between collection of the sample and the actual analysis, are described in this report. It must be emphasized, however, that almost invariably each of the methods described is based on the total oxidizing capacity of the solution being analyzed and is readily subject to interferences from the presence of other potential oxidizing agents and/or intermediates from concomitant chemical reactions. Under ideal conditions some of the methods are accurate to better

than it--especially in the absence of common interferences--whereas other methods are almost semi-quantitative in nature with many common species interfering with both the precision and accuracy of the measurements.

We have also included chlorate ion as a residual species in that only recently have reliable analytical methods begun to appear in the literature (5,6,10). We also report on the chemistry of the chlorine-ammonia system and the associated breakpoint reactions, because one of the most common interferences in the measurement of free chlorine is monochloramine.

The most important development for this report has been the decision to include a preliminary section describing an "idealized" analytical method. The need for this section became apparent as our writing progressed describing each of the analytical methods for chlorine. Specific items included in this "idealized" method are accuracy, precision, reproducibility, lack of interferences, ease of use of the method, lack of false positive values, and so forth.

The benefit of the "idealized" analytical method is to allow individual comparisons and to allow the choice between various methods based on individual method shortcomings. For example, a particular method might have as its only difficulty interference by manganese and iron. In many circumstances, this type of interference might be a major problem. However, should the water supply under consideration not have any manganese or iron, it is quite likely that the method might be very usable--and as a matter of fact well might be the best method of choice.

In other cases, speed of analysis rather than potential interferences (or choice of some other important characteristic) might be the guiding factor in choosing an analytical method. In this way rational choices can be made based on potential and/or real difficulties and/or interferences and as compared to an "idealized" method -- rather than a possibly controversial existing method.

Table I has been constructed as a quick reference guide to the available methods for the determination of water disinfection chemicals and byproducts. Included are pertinent analytical characteristics such as detection limits, working range, interferences, accuracy and precision estimates. The current status of the method, as gleaned from this report, is given. The necessary operator skill level is given to aid the laboratory manager in assessing the manpower requirements for a particular method. Additional information concerning the reasons for the current status is contained in the Recommendation Section of the Executive Summary and the complete report.

As each of the methods is described in detail in the full report, specific conclusions are drawn--along with appropriate recommendations--by comparing the method against the "idealized" analytical method for that species.

One additional benefit of this direct comparison is the possibility of adding or subtracting a method to the list of Standard Methods for the Examination of Water and Wastewater (13), based on a rational set of criteria. It should also be possible in the future to decide on the viability of various methods based on their meeting specific criteria rather than based only on comparisons between analytical laboratories (and personalized subjective reactions to the various methods themselves

TABLE I. CHARACTERISTICS AND COMPARISONS OF ANALYTICAL METHODS^o

<u>TYPE OF TEST (METHOD)¹</u>	<u>Species¹ MEASURED DIRECTLY</u>	<u>DETECTION LIMIT (mg/L)</u>	<u>WORKING RANGE (mg/L)</u>	<u>EXPECTED ACCURACY (± %)</u>	<u>EXPECTED PRECISION (± %)</u>	<u>SKILL^o LEVEL</u>
FREE CHLORINE						
"Ideal"	Cl ₂ + HOCl/OCl ⁻	0.001	0.001 - 10	0.5	0.1	1
UV/VISIBLE	Cl ₂ + HOCl/OCl ⁻	- 1	1 - 100	NR	NR	3
Continuous	Cl ₂ + HOCl/OCl ⁻	1.5	1.5 - 300	NR	NR	3
AMPEROMETRIC TITRATION:						
Forward	Cl ₂ + HOCl/OCl ⁻	0.0018 ¹	> 10	NF	NF	2
		0.02 - 0.03 ²	> 10	NF	3 - 50	2
Back	Cl ₂ + HOCl/OCl ⁻	0.002	> 10	3 - 50	NF	2
Continuous	Cl ₂ + HOCl/OCl ⁻	0.005	> 10	NR	1.0	2/3
IODOMETRIC TITRATION:						
Standard (Total Chlorine)		0.07 ³	0.1 - 10	NR	NR	2
		0.35 ⁴	0.5 - 10	NR	NR	2
DPD						
FAS Tit'n	Cl ₂ + HOCl/OCl ⁻	0.004 ³	0.01 - 10	NF	2 - 7	1
		0.011 ⁴	0.01 - 10	NF	2 - 7	1
Color'metric	Cl ₂ + HOCl/OCl ⁻	0.01 ⁵	0.01 - 10	1 - 15	1 - 14	1
Steadifac	Cl ₂ + HOCl/OCl ⁻	0.01 ⁵	0.01 - 10	NF	NR	1/2
LCV						
Black and Whittle	Cl ₂ + HOCl/OCl ⁻	0.01	0.25 - 3	NF	NR	1
Whittle & Lapteff	Cl ₂ + HOCl/OCl ⁻	0.01	0.25 - 10	NR	0 - 10	2

TABLE I. CHARACTERISTICS (cont'd)

<u>STABILITY</u> <u>REAGENT</u>	<u>PRODUCTS</u>	<u>INTERFERENCES</u>	<u>pH RANGE</u>	<u>FIELD TEST</u>	<u>AUTOMATED</u>	<u>CURRENT STATUS</u>
5 YRS	> 1 DAY	NONE	Independent	YES	YES	RECOMMENDED
NA	NA	ClNH ₂ - Cl ₃ N backgnd Abs	pH Dependent	NO	NO	RECOMMENDED (LAB TEST)
NA	NA	ClNH ₂ - Cl ₃ N	pH Dependent	NO	YES	CONT'D STUDY
1-2 yrs	NA	ClNH ₂ - Cl ₃ N	pH Dependent	YES	YES	RECOMMENDED
1-2 yrs	NA	ClNH ₂ - Cl ₃ N	pH Dependent	YES	YES	RECOMMENDED
1-2 yrs	NA	ClNH ₂ - Cl ₃ N	pH Dependent	YES	YES	RECOMMENDED
1-2 yrs	NA	ClNH ₂ - Cl ₃ N	pH Dependent	YES	YES	RECOMMENDED
1 yr	10 min or less	All oxidizing species	pH Dependent	NO	NO	RECOMMENDED (LAB TEST)
1 yr	10 min or less	All oxidizing species	pH Dependent	NO	NO	RECOMMENDED (LAB TEST)
powder stable ^a	30 min	ClNH ₂ - Cl ₃ N oxid species	Requires buffer	NO	NO	RECOMMENDED (LAB TEST)
powder stable ^a	30 min	ClNH ₂ - Cl ₃ N oxid species	Requires buffer	NO	NO	RECOMMENDED (LAB TEST)
powder stable ^a	30 min	ClNH ₂ - Cl ₃ N oxid species	Requires buffer	YES	NO	RECOMMENDED (FIELD TEST)
powder stable ^a	30 min	ClNH ₂ - Cl ₃ N oxid species	Requires buffer	YES	NO	RECOMMENDED (FIELD TEST)
months	NR	ClNH ₂ - Cl ₃ N oxid species	Requires buffer	YES	NO	ABANDON
months	NR	Oxidizing species	Buffering	YES	NO	RECOMMENDED (LAB TEST)

TABLE I. CHARACTERISTICS AND COMPARISONS OF ANALYTICAL METHODS[®] (cont'd)

<u>TYPE OF TEST (METHOD)[†]</u>	<u>Species[†] MEASURED DIRECTLY</u>	<u>DETECTION LIMIT (mg/L)</u>	<u>WORKING RANGE (mg/L)</u>	<u>EXPECTED ACCURACY (± %)</u>	<u>EXPECTED PRECISION (± %)</u>	<u>SKILL[†] LEVEL</u>
FACTS						
Color'metric	Cl ₂ + HOCl/OCl ⁻	0.1	0.25 - 10	5 - 20	1 - 11	1
Spect'photo	Cl ₂ + HOCl/OCl ⁻	0.012	0.05 - 10	NR	NR	1
METHYL ORANGE	Cl ₂ + HOCl/OCl ⁻	NR	NR	NR	NR	2
O-TOLIDINE	Cl ₂ + HOCl/OCl ⁻	NR	NR	NR	NR	1
3,3'-DIMETHYLNAPHTHIDINE		-				
	Cl ₂ + HOCl/OCl ⁻	0.05	NR	NR	2 - 6	2/3
O-DIANISIDINE	Cl ₂ + HOCl/OCl ⁻	0.1	NR	NR	NR	2/3
CHEMILUMINESCENCE						
Hydrogen Peroxide	Cl ₂ + HOCl/OCl ⁻	NR	NR	NR	NR	3
Luminol	OCl ⁻	0.0007	NR	NR	NR	3
Lophine	OCl ⁻	0.14	0.2 - 20	NR	NR	3
ELECTRODE METHODS						
Membrane	HOCl	0.004	0.04 - 1	NR	1.6	3
Bare-wire	Cl ₂ + HOCl/OCl ⁻	0.1	0.1 - 3	NR	1 - 25	3
Potent'metric	Cl ₂ + HOCl/OCl ⁻	0.005	0.01 - 1	1 - 6	7 - 10	2
AgI Volt'metric	Cl ₂ + HOCl/OCl ⁻	0.01	0.1 - 10	NR	NR	3

TABLE I. CHARACTERISTICS (cont'd)

<u>STABILITY</u> <u>REAGENT</u>	<u>PRODUCTS</u>	<u>INTERFERENCES</u>	<u>pH RANGE</u>	<u>FIELD TEST</u>	<u>AUTOMATED</u>	<u>CURRENT STATUS</u>
2 years'	30 min at high Cl ₂	Oxidizing species	Buffering critical	YES	NO	RECOMMENDED
2 years'	30 min at high Cl ₂	Oxidizing species	Buffering critical	YES	NO	RECOMMENDED
NF	NF	Oxidizing species	Buffering required	YES	NO	ABANDON
NF	NF	Oxidizing species	Buffering required	YES	NO	ABANDON
NF	15-20 min	Oxidizing species	NR	NO	NO	ABANDON
NF	55 min	Oxidizing species	NR	NO	NO	ABANDON
NR	<1 sec	None	Independent	NO	POSSIBLE	ABANDON
NR	<1 sec	Oxidizing species	pH Dependent	NO	POSSIBLE	CONT'D STUDY
NR	<1 sec	None	pH Dependent	NO	YES	CONT'D STUDY
NA	NA	Oxidizing Gas species	Dependent on pH	POSSIBLE	POSSIBLE	CONT'D STUDY
NA	NA	Oxidizing species, Cl ⁻	NR	POSSIBLE	POSSIBLE	CONT'D STUDY
3 months	NA	Oxidizing species Cl ⁻	pH Dependent	YES	YES	RECOMMENDED
NA	NA	Oxidizing species, Cl ⁻	Buffer required	POSSIBLE	POSSIBLE	CONT'D STUDY

TABLE I. CHARACTERISTICS AND COMPARISONS OF ANALYTICAL METHODS^o (cont'd)

<u>TYPE OF TEST (METHOD)^o</u>	<u>Species^o MEASURED DIRECTLY</u>	<u>DETECTION LIMIT (mg/L)</u>	<u>WORKING RANGE (mg/L)</u>	<u>EXPECTED ACCURACY (± %)</u>	<u>EXPECTED PRECISION (± %)</u>	<u>SKILL^o LEVEL</u>
TOTAL CHLORINE^o						
"Ideal"	Cl ₂ + HOCl/OCl ⁻ NH ₂ Cl NHCl ₂ NCl ₃	0.001	0.001 - 10	0.5	0.1	1
AMPEROMETRIC TITRATION:						
Forward	Cl ₂ + HOCl/OCl ⁻ NH ₂ Cl NHCl ₂ NCl ₃	0.0018 ¹	> 10	NF	NF	2
	Cl ₂ + HOCl/OCl ⁻ NH ₂ Cl NHCl ₂ NCl ₃	0.02 - 0.03 ²	> 10	NF	3 - 50	2
Back	Cl ₂ + HOCl/OCl ⁻ NH ₂ Cl NHCl ₂ NCl ₃	0.002	> 10	3 - 50	NF	2
Continuous	Cl ₂ + HOCl/OCl ⁻ NH ₂ Cl NHCl ₂ NCl ₃	0.005	> 10	NR	1.0	2/3
IODOMETRIC TITRATION:						
Standard	Cl ₂ + HOCl/OCl ⁻ NH ₂ Cl NHCl ₂ NCl ₃	0.07 ³	0.1 - 10	NR	NR	2
	Cl ₂ + HOCl/OCl ⁻ NH ₂ Cl NHCl ₂ NCl ₃	0.35 ⁴	0.5 - 100	NR	NR	2
DPD						
FAS Tit'n	Cl ₂ + HOCl/OCl ⁻ NH ₂ Cl NHCl ₂ NCl ₃	0.004 ⁵	0.01 - 10	NF	2 - 7	1
	Cl ₂ + HOCl/OCl ⁻ NH ₂ Cl NHCl ₂ NCl ₃	0.11 ⁴	0.01 - 10	NF	2 - 7	1
Color'metric	Cl ₂ + HOCl/OCl ⁻ NH ₂ Cl NHCl ₂ NCl ₃	0.001 ⁵	0.01 - 10	1 - 15	1 - 14	1
LCV						
Black & Whittle	Cl ₂ + HOCl/OCl ⁻ NH ₂ Cl NHCl ₂ NCl ₃	0.005	0.25 - 3	NF	4 - 10	1

TABLE I. CHARACTERISTICS (cont'd)

<u>STABILITY</u> <u>REAGENT</u>	<u>PRODUCTS</u>	<u>INTERFERENCES</u>	<u>pH RANGE</u>	<u>FIELD TEST</u>	<u>AUTOMATED</u>	<u>CURRENT STATUS</u>
5 YRS	> 1 DAY	NONE	Independent of pH	YES	YES	RECOMMENDED
1 - 2 yrs	NA	Oxidizing Species	pH Dependent	YES	YES	RECOMMENDED
1 - 2 yrs	NA	Oxidizing Species	pH Dependent	YES	YES	RECOMMENDED
1 - 2 yrs	NA	Oxidizing Species	pH Dependent	YES	YES	RECOMMENDED
1 - 2 yrs	NA	Oxidizing Species	pH Dependent	YES	YES	RECOMMENDED
1 yr	10 min	All oxidizing species	pH Dependent	NO	NO	RECOMMENDED (LAB TEST)
1 yr	10 min	All oxidizing species	pH Dependent	NO	NO	RECOMMENDED (LAB TEST)
powder stable ^c	30 min	Oxidizing Species	Requires buffer	NO	NO	RECOMMENDED (LAB TEST)
powder stable ^c	30 min	Oxidizing Species	Requires buffer	YES	NO	RECOMMENDED (FIELD TEST)
powder stable ^c	30 min	Oxidizing Species	Requires buffer	YES	NO	RECOMMENDED (FIELD TEST)
months	NR	Oxidizing Species	Requires buffer	YES	NO	ABANDON

TABLE I. CHARACTERISTICS AND COMPARISONS OF ANALYTICAL METHODS^o (cont'd)

<u>TYPE OF TEST (METHOD)¹</u>	<u>Species¹ MEASURED DIRECTLY</u>	<u>DETECTION LIMIT (mg/L)</u>	<u>WORKING RANGE (mg/L)</u>	<u>EXPECTED ACCURACY (± %)</u>	<u>EXPECTED PRECISION (± %)</u>	<u>SKILL¹ LEVEL</u>
Whittle & Lapteff	Cl ₂ + HOCl/OCl ⁻ NH ₂ Cl NHCl ₂ NCl ₃	0.01	0.25 - 10	NF	4 - 10	2
FACTS						
Color'metric	Cl ₂ + HOCl/OCl ⁻ NH ₂ Cl NHCl ₂ NCl ₃	0.1	0.25 - 10	5 - 20	1 - 11	1
Spect'photo	Cl ₂ + HOCl/OCl ⁻ NH ₂ Cl NHCl ₂ NCl ₃	0.012	0.05 - 10	NF	NR	1
ELECTRODE METHODS						
Pot'metric	Cl ₂ + HOCl/OCl ⁻ NH ₂ Cl NHCl ₂ NCl ₃	0.005	0.01 - 1	1 - 6	7 - 10	2
MONOCHLORAMINE ^o						
"Ideal"	NH ₂ Cl	0.001	0.001 - 10	0.5	0.1	1
UV/VISIBLE	NH ₂ Cl	- 1	1 - 100	NR	NR	3
AMPEROMETRIC TITRATION:						
Forward	NH ₂ Cl	NR	> 10	NF	0 - 10	2
Back	NH ₂ Cl	NR	> 10	NF	NF	2
DPD						
FAS Tit'n	NH ₂ Cl	NR	0.01 - 10	NF	2 - 7	1
Color'metric	NH ₂ Cl	NR	0.01 - 10	NF	5 - 75	1

TABLE I. CHARACTERISTICS (cont'd)

<u>STABILITY</u> <u>REAGENT</u>	<u>PRODUCTS</u>	<u>INTERFERENCES</u>	<u>pH RANGE</u>	<u>FIELD TEST</u>	<u>AUTOMATED</u>	<u>CURRENT STATUS</u>
months	NR	Oxidizing Species	Buffering	YES	NO	RECOMMENDED (LAB TEST)
2 YRS	30 min at high Cl ₂	Oxidizing Species	Buffering critical	YES	NO	RECOMMENDED
2 YRS	30 min at high Cl ₂	Oxidizing species	Buffering critical	YES	NO	RECOMMENDED
3 months	NA	Oxidizing Species, Cl ⁻	pH Dependent	YES	YES	RECOMMENDED
5 YRS	> 1 DAY	NONE	Independent	YES	YES	RECOMMENDED
NA	NA	Cl ₂ NH - Cl ₃ N backgnd Abs	pH Dependent	NO	NO	RECOMMENDED (LAB TEST)
1-2 yrs	NA	Cl ₂ NH - Cl ₃ N	pH Dependent	YES	YES	RECOMMENDED
1-2 yrs	NA	Cl ₂ NH - Cl ₃ N	pH Dependent	YES	YES	RECOMMENDED
powder stable ^a	30 min	ClNH ₂ - Cl ₃ N oxid species	Requires buffer	NO	NO	RECOMMENDED (LAB TEST)
powder stable ^a	30 min	ClNH ₂ - Cl ₃ N oxid species	Requires buffer	YES	NO	RECOMMENDED (FIELD TEST)

TABLE I. CHARACTERISTICS AND COMPARISONS OF ANALYTICAL METHODS² (cont'd)

<u>TYPE OF TEST (METHOD)¹</u>	<u>Species¹ MEASURED DIRECTLY</u>	<u>DETECTION LIMIT (mg/L)</u>	<u>WORKING RANGE (mg/L)</u>	<u>EXPECTED ACCURACY (± %)</u>	<u>EXPECTED PRECISION (± %)</u>	<u>SKILL¹ LEVEL</u>
LCV						
Whittle & Lapteff	NH ₂ Cl	NR	0.25 - 10	NF	0 - 43	2
ELECTRODE METHODS						
Silver iodide Voltammetric	NH ₂ Cl	NR	0.1 - 10	NR	NR	3
DICHLORAMINE ²						
"Ideal"	NHCl ₂	0.001	0.001 - 10	0.5	0.1	1
UV/VISIBLE	NHCl ₂	- 1	1 - 100	NR	NR	3
AMPEROMETRIC TITRATION:						
Forward	NHCl ₂	NR	> 10	NF	0	2
Back	NHCl ₂	NR	> 10	3 - 50	NF	2
DPD						
FAS Tit'n	NHCl ₂	NR	0.01 - 10	NF	NF	1
Color'metric	NHCl ₂	NR	0.01 - 10	NF	0 - 100	1
LCV						
Whittle & Lapteff	NHCl ₂	NR	0.25 - 10	NF	10 - 150	2

TABLE I. CHARACTERISTICS (cont'd)

<u>STABILITY</u> <u>REAGENT</u>	<u>PRODUCTS</u>	<u>INTERFERENCES</u>	<u>pH RANGE</u>	<u>FIELD</u> <u>TEST</u>	<u>AUTOMATED</u>	<u>CURRENT</u> <u>STATUS</u>
months	NR	Oxidizing species	Requires buffer	YES	NO	RECOMMENDED (LAB TEST)
NA	NA	Oxidizing species	Requires buffer	POSSIBLE	POSSIBLE	CONT'D STUDY
5 YRS	> 1 DAY	NONE	Independent of pH	YES	YES	RECOMMENDED
NA	NA	ClNH ₂ & Cl ₃ N backgd Abs	pH Dependent	NO	NO	RECOMMENDED (LAB TEST)
1-2 yrs	NA	ClNH ₂ & Cl ₃ N	pH Dependent	YES	YES	RECOMMENDED
1-2 yrs	NA	ClNH ₂ & Cl ₃ N	pH Dependent	YES	YES	RECOMMENDED
powder stable ^a	30 min	ClNH ₂ & Cl ₃ N oxid species	Requires buffer	NO	NO	RECOMMENDED (LAB TEST)
powder stable ^a	30 min	ClNH ₂ & Cl ₃ N oxid species	Requires buffer	YES	NO	RECOMMENDED (FIELD TEST)
months	NR	Oxidizing species	Requires buffer	YES	NO	RECOMMENDED (LAB TEST)

TABLE I. CHARACTERISTICS AND COMPARISONS OF ANALYTICAL METHODS² (cont'd)

<u>TYPE OF TEST (METHOD)¹</u>	<u>Species¹ MEASURED DIRECTLY</u>	<u>DETECTION LIMIT (mg/L)</u>	<u>WORKING RANGE (mg/L)</u>	<u>EXPECTED ACCURACY (± %)</u>	<u>EXPECTED PRECISION (± %)</u>	<u>SKILL² LEVEL</u>
TRICHLORAMINE²						
"Ideal"	NCl ₃	0.001	0.001 - 10	0.5	0.1	1
UV/VISIBLE	NCl ₃	NR	NR	NR	NR	3
AMPEROMETRIC TITRATION:						
Forward	NCl ₃	NR	> 10	NF	5 - 100	2
DPD						
FAS Tit'n	NCl ₃	NR	0.01 - 10	NR	NR	1
Color'metric	NCl ₃	NR	0.01 - 10	NR	NR	1
LCV						
Whittle & Lapteff	NCl ₃	NR	0.25 - 10	NR	NR	2
CHLORINE DIOXIDE						
"Ideal"	ClO ₂	0.001	0.001 - 10	0.5	0.1	1
IODOMETRIC	ClO ₂	0.002	0.002 - 95	1 - 2	1 - 2	2
AMPEROMETRIC	ClO ₂ ¹⁰	0.012	0.02 - ??	1 - 15	1 - 15	3
DPD	ClO ₂ ¹⁰⁻¹¹	0.008	0.008 - 20	10	7 - 15	2
UV						
Manual	ClO ₂	0.05	0.05 - 500	5	5	2
FIA	ClO ₂	0.25	0.25 - 142	2	1	1

TABLE I. CHARACTERISTICS (cont'd)

<u>STABILITY</u> <u>REAGENT</u>	<u>PRODUCTS</u>	<u>INTERFERENCES</u>	<u>pH RANGE</u>	<u>FIELD TEST</u>	<u>AUTOMATED</u>	<u>CURRENT STATUS</u>
5 YRS	> 1 DAY	NONE	Independent	YES	YES	RECOMMENDED
NA	NA	ClNH ₂ - Cl ₂ NH backgnd Abs HOCl/OCl ⁻	pH Dependent	NO	NO	RECOMMENDED (LAB TEST)
1-2 yrs	NA	ClNH ₂ - Cl ₂ NH	pH Dependent	NO	YES	RECOMMENDED (LAB TEST)
powder stable ^a	30 min	ClNH ₂ - Cl ₂ NH oxid species	Requires buffer	NO	NO	RECOMMENDED (LAB TEST)
powder stable ^a	30 min	ClNH ₂ - Cl ₂ NH oxid species	Requires buffer	YES	NO	RECOMMENDED (LAB TEST)
months	NR	Oxidizing species	Requires buffer	YES	NO	RECOMMENDED (LAB TEST)
5 YRS	> 1 DAY	NONE	Independent	YES	YES	RECOMMENDED
1 YR	Subject to oxidation	Oxidizing species	2 - 5	NO	NO	NOT RECOMMENDED
good	Subject to oxidation	Metal ions & nitrite ion	7	NO	NO	CURRENTLY USED
solid stable ^a	< 30 min	Oxidizing species	7	NO	NO	NOT RECOMMENDED
none	none	Other UV absorbers.	Independent	NO	YES	RECOMMENDED (LAB TEST)
none	none	none	Independent	NO	YES	RECOMMENDED (LAB TEST)

TABLE I. CHARACTERISTICS AND COMPARISONS OF ANALYTICAL METHODS[®] (cont'd)

<u>TYPE OF TEST (METHOD)[†]</u>	<u>Species[†] MEASURED DIRECTLY</u>	<u>DETECTION LIMIT (mg/L)</u>	<u>WORKING RANGE (mg/L)</u>	<u>EXPECTED ACCURACY (± %)</u>	<u>EXPECTED PRECISION (± %)</u>	<u>SKILL[•] LEVEL</u>
ACVK ^{1,2}	ClO ₂	0.04	0 - 25	NR	NR	1
CHLOROPHENOL RED	ClO ₂	0.003	0.003 - 1	10	5	1
o-TOLIDINE	ClO ₂	0.1	NR	NR	NR	1
INDIGO BLUE	ClO ₂	0.01	NR	NR	1.5	1
CHEMILUMINESCENCE						
Luminol	ClO ₂	0.3	0.3 - 1	NR	8	1
GDFIA ^{1,3}	ClO ₂	0.005	0.005 - 74	2	1	1
ELECTROCHEM.						
Pt Microelec.	ClO ₂ + ClO ₂ ⁻	1.3	NR	7	NR	2/3
Vit. Carbon	ClO ₂	32	NR	NR	NR	3
Voltam. Mem.	ClO ₂	0.25	NR	NR	NR	2
Rotating Volt. Membrane	ClO ₂	0.30	0.30 - 3	NR	6.4	2/3
CHLORITE ION						
"Ideal"	ClO ₂ ⁻	0.001	0.001 - 10	0.5	0.1	1
AMPEROMETRIC						
Iodometric	ClO ₂ ⁻	0.05	0.05 - 95	5	5	2
IODOMETRIC						
Sequential	ClO ₂ ⁻	0.011	> 1	1	1	3
Modified	ClO ₂ ⁻	0.3	0.5 - 20	0.5	1 - 3	3
DPD	ClO ₂ ⁻	0.01	0.01 - 10	5	5	2

TABLE I. CHARACTERISTICS (cont'd)

<u>STABILITY</u> <u>REAGENT</u>	<u>PRODUCTS</u>	<u>INTERFERENCES</u>	<u>pH RANGE</u>	<u>FIELD</u> <u>TEST</u>	<u>AUTOMATED</u>	<u>CURRENT</u> <u>STATUS</u>
NR	NR	minimal	8.1 - 8.4	NO	NO	CONT'D STUDY
6 months	NR	unknown	7	YES	NO	NOT RECOMMENDED
NR	NR	Oxidizing species	NR	NO	NO	NOT RECOMMENDED
good	good	O ₃ , Cl ₂	> 4	NO	NO	NOT RECOMMENDED
1 DAY	< 1 sec	NR	NR	NO	NO	NOT RECOMMENDED
1 DAY	< 1 sec	Cl ₂	> 12	NO	YES	RECOMMENDED CONT'D STUDY
none	none	ClO ₂ ⁻	5 - 5.5	NO	NO	CONT'D STUDY
none	none	ClO ₂ ⁻	3.5 - 7	NO	NO	CONT'D STUDY
none	none	HOCl	7.8	NO	NO	CONT'D STUDY
none	none	HOCl	5 - 5.5	NO	NO	CONT'D STUDY
5 YRS	> 1 DAY	NONE	Independent	YES	YES	RECOMMENDED
1 YR	Subject to oxidation	Oxidizing species	2 - 5	NO	NO	NOT RECOMMENDED
good	Subject to oxidation	Metal ions & nitrite ion	7	NO	NO	RECOMMENDED AT HIGH CONC.
good	Subject to oxidation	Metal ions & nitrite ion	2	NO	NO	CONT'D STUDY
Solid stable ^o	< 30 min	Oxidizing species	7	NO	NO	NOT RECOMMENDED

TABLE I. CHARACTERISTICS AND COMPARISONS OF ANALYTICAL METHODS² (cont'd)

<u>TYPE OF TEST (METHOD)¹</u>	<u>Species¹ MEASURED DIRECTLY</u>	<u>DETECTION LIMIT (mg/L)</u>	<u>WORKING RANGE (mg/L)</u>	<u>EXPECTED ACCURACY (± %)</u>	<u>EXPECTED PRECISION (± %)</u>	<u>SKILL² LEVEL</u>
CHLORATE ION						
"Ideal"	ClO ₃ ⁻	0.001	0.001 - 10	0.5	0.1	1
IODOMETRIC						
Sequential	ClO ₃ ⁻	0.064	> 1	2	- 2 - 5	3
Modified	ClO ₃ ⁻	0.3	0.3 - 20	1	1 - 3	3
FIA	ClO ₃ ⁻	0.08	0.08 - 0.8	3.5	1	2
DPD	ClO ₃ ⁻	0.01	0.01 - 10	5	5	2
OZONE						
"Ideal"	O ₃	0.01	0.01 - 10	0.5	0.1	1
IODOMETRIC	O ₃	0.002	0.5 - 100	1 - 35	1 - 2	2
ARSENIC BACK TITRATION	O ₃	0.002	0.5 - 65	1 - 5	1 - 2	2
FACTS	O ₃	0.02	0.5 - 5	5 - 20	1 - 5	2
DPD	O ₃	0.1	0.2 - 2	5 - 20	5	2
INDIGO						
Spect'photo	O ₃	0.001	0.01 - .1	1	0.5	1
		0.006	0.05 - .5	1	0.5	1
		0.1	> 0.3	1	0.5	1

TABLE I. CHARACTERISTICS (cont'd)

<u>STABILITY</u> <u>REAGENT</u>	<u>PRODUCTS</u>	<u>INTERFERENCES</u>	<u>pH RANGE</u>	<u>FIELD TEST</u>	<u>AUTOMATED</u>	<u>CURRENT STATUS</u>
5 YRS	> 1 DAY	NONE	Independent	YES	YES	RECOMMENDED
good	Subject to oxidation	Metal ions & nitrite ion	7	NO	NO	RECOMMENDED AT HIGH CONC.
good	Subject to oxidation	Metal ions & nitrite ion	2	NO	NO	CONT'D STUDY
1 year	1 day	Oxidizing species	< 1	NO	YES	USED AFTER ALL ClO_2 , ClO_2^- GONE
Solid stable*	< 30 min	Oxidizing species	7	NO	NO	NOT RECOMMENDED
5 YRS	> 1 DAY	NONE	Independent	YES	YES	RECOMMENDED
1 YR	subject to oxidation	All ozone by products and oxidants	< 2	NO	NO	ABANDON
1 YR	subject to oxidation	Oxidizing species	6.8	NO	NO	CONT'D STUDY
2 YRS	no fading first 5 min	Oxidizing species	6.6	NO	NO	NOT RECOMMENDED
Solid stable*	< 30 min	Oxidizing species	6.4	NO	NO	NOT RECOMMENDED
good	good	Cl_2 , Mn ions Br_2 , I_2	2	NO	YES	RECOMMENDED
good	good	Cl_2 , Mn ions Br_2 , I_2	2	NO	YES	RECOMMENDED
good	good	Cl_2 , Mn ions Br_2 , I_2	2	NO	YES	RECOMMENDED

TABLE I. CHARACTERISTICS AND COMPARISONS OF ANALYTICAL METHODS[®] (cont'd)

<u>TYPE OF TEST (METHOD)[†]</u>	<u>Species[†] MEASURED DIRECTLY</u>	<u>DETECTION LIMIT (mg/L)</u>	<u>WORKING RANGE (mg/L)</u>	<u>EXPECTED ACCURACY (± %)</u>	<u>EXPECTED PRECISION (± %)</u>	<u>SKILL[•] LEVEL</u>
INDIGO (cont'd)						
Visual	O ₃	0.1	0.01 - 0.1	5	5	1
			> 0.1	5	5	1
GDFIA	O ₃	0.03	0.03 - 0.4 other ranges possible	1	0.5	2
LCV	O ₃	0.005	NR	NR	NR	1
ACVK	O ₃	0.25	0.05 - 1	NR	NR	1
o-TOLIDINE	O ₃	NOT QUANTITATIVE		NR	NR	1
BISTERPYRIDINE	O ₃	0.004	0.05 - 20	2.7	2.1	3
CARMINE INDIGO	O ₃	< 0.5	NR	NR	NR	1
ELECTROCHEM						
Amperometric	Total oxidants	- 1	NR	5	5	2
Amperometric iodometric	Total Oxidants	- 0.5	NR	5	5	2
Bare electrode	O ₃	0.2	NF	5	5	2
Membrane elect.	O ₃	0.062	NF	5	5	1
Differential Pulse Dropping Mercury	O ₃	NR	NR	NR	NR	3
Differential Pulse Polar- ography	O ₃	0.003	NR	NR	NR	3
Potentiometric	O ₃	NR	NR	NR	NR	1

TABLE I. CHARACTERISTICS (cont'd)

<u>STABILITY</u> <u>REAGENT</u>	<u>PRODUCTS</u>	<u>INTERFERENCES</u>	<u>pH RANGE</u>	<u>FIELD</u> <u>TEST</u>	<u>AUTOMATED</u>	<u>CURRENT</u> <u>STATUS</u>
good	good	Cl ₂ , Mn ions	2	YES	NO	RECOMMENDED
good	good	Br ₂ I ₂ Cl ₂ , Mn ions	2	YES	NO	RECOMMENDED
good	good	Br ₂ I ₂				
good	good	Cl ₂ at > 1mg/L	2	NO	YES	COMPARISON STUDIES NEEDED
Stable	Stable	S ²⁻ SO ³⁻ Cr ⁶⁺	2	NO	NO	CONT'D STUDY
NR	NR	Mn > 1 mg/L Cl ₂ > 10 mg/L	2	NO	NO	CONT'D STUDY
NR	NR	Metal ions, NO ₂ ⁻	2	YES	NO	ABANDON
Good	Good	Cl ₂	< 7	NO	YES	RECOMMENDED (LAB TEST)
NR	NR	NR	2	NO	NO	CONT'D STUDY
none	NA	Oxidizing species	2	NO	YES	RELATIVE MONITORING
1 YR	Subject to oxidation	Oxidizing species	4 - 4.5	NO	NO	NOT RECOMMENDED
none	NR	NR	NR	NO	YES	CONT'D STUDY
none	NR	NR	NR	NO	POSSIBLE	CONT'D STUDY
none	NR	NR	NR	NO	NO	RESEARCH LAB
none	NR	NR	4	NO	NO	CONT'D STUDY
none	NR	NR	NR	NO	YES	CONT'D STUDY

TABLE I. CHARACTERISTICS AND COMPARISONS OF ANALYTICAL METHODS^a

<u>TYPE OF TEST (METHOD)[†]</u>	<u>Species[‡] MEASURED DIRECTLY</u>	<u>DETECTION LIMIT (mg/L)</u>	<u>WORKING RANGE (mg/L)</u>	<u>EXPECTED ACCURACY (± %)</u>	<u>EXPECTED PRECISION (± %)</u>	<u>SKILL[*] LEVEL</u>
UV	O ₃	0.02	> 0.02	0.5 ^{1,4}	0.5	1
ISOTHERMAL PRESSURE CHANGE	O ₃	4 x 10 ⁻⁵	4 x 10 ⁻⁵ - 10	0.5	0.5	1
OZONE GAS PHASE						
"Ideal"	O ₃	1	1 - 50,000	1	1	1
UV	O ₃	0.5	0.5 - 50,000	2	2.5	1/2
Stripping Absorption Iodometry	O ₃	0.002	0.5 - 100	1 - 35	1 - 2	2
Chemiluminescence	O ₃	0.005	0.005 - 1	7	5	1/2
Gas phase titration	O ₃	0.005	0.005 - 30	8	3.5	2
Rhodamine B/ Gallic Acid	O ₃	0.001	NR	NR	5	1
Amperometry	O ₃	NR	NR	NR	NR	1

- [‡] for page numbers in the full report, refer to the Alphabetical Index
[†] direct determination of the species measured without interferences
^{*} Operator Skill Levels: 1 - minimal, 2 - good technician,
 3 - experienced chemist

NA Not applicable

NR Not reported

NF Not found

1 Using research grade electrochemical equipment

2 Using commercial titrator

3 Spectrophotometric endpoint detection

4 Visual endpoint detection.

5 Using test kit

6 Liquid reagent is unstable

7 Stability is very dependent on the purity of the 2-propanol used

TABLE I. CHARACTERISTICS (cont'd)

<u>REAGENT</u>	<u>STABILITY PRODUCTS</u>	<u>INTERFERENCES</u>	<u>pH RANGE</u>	<u>FIELD TEST</u>	<u>AUTOMATED</u>	<u>CURRENT STATUS</u>
none	NA	Other Absorber	Independent	NO	YES	ESTABLISH MOLAR ABSORB-TIVITY
none	good	none	Independent	NO	YES	COMPARISON STUDY
none	none	none	Independent	YES	YES	RECOMMENDED
none	none	none	NA	YES	YES	RECOMMENDED
good	good	SO ₂ , NO ₂	NA	YES	NO	ABANDON
stable	< 1 sec	none	NA	YES	YES	RECOMMENDED
stable	stable	none	NA	YES	NO	NOT RECOMMENDED
problems		NR	NA	YES	POSSIBLE	NOT RECOMMENDED
none	none	NR	NA	YES	YES	NOT RECOMMENDED

-
- 8 Total Chlorine is all chlorine species with +1 oxidation state
 9 Very little actual work has been carried out on selective determination of chloramines. The values reported are from extrapolated studies that had objectives other than the selective determination of chloramines. Most methods are indirect procedures which are not recommended
 10 Indirect method
 11 1/3 of ClO₂ determined
 12 Acid chrome violet potassium (ACVK)
 13 Gas diffusion flow injection analysis (GDFIA)
 14 Based on current molar absorbtivity and proper sample handling techniques. Current best estimates of molar absorbtivity of 2900-3300 give a possible error of > 10%.
- © Taken from Gordon, Cooper, Rice, and Pacey, AWWA-RF Review on "Disinfectant Residual Measurements Methods" (1987)
-

Chapter 4 (Indexed Reference Citations) has been included in this report in order to assist readers in locating particular papers of interest. The 48 categories for chlorine, chloramines, and the oxy-chlorine species, along with the additional 60 categories for ozone, should make the task of finding individual papers of interest considerably less cumbersome. Papers which describe several methods have been included in each of the appropriate categories. All together, the 1,400 references cited in Chapters 1-3 number more than 2,000 individual citations when distributed in the indexed form of Chapter 4.

Chapter 5 is an alphabetical listing of the individual references citations. Finally, a detailed Index has been included in order to assist readers in locating subjects of specific interest. We hope the readers will find these additional chapters as useful as have we in preparing this report.

RECOMMENDATIONS

General Statements on Comparisons.

There have been and will continue to be reports of methods comparison. One of the most important considerations for a method is accuracy, i.e. the ability of the method to determine the correct concentration of a disinfectant in solution. An equally important consideration is precision, i.e. how well does the analytical method reproducibly measure the same concentration. Frequently experiments are conducted to determine the "equivalency" of the methods. From such results, methods may be found to be equivalent, but the only analytical considerations tested were accuracy, as judged by a Reference Method, and precision, judged for each method based on the experimental design.

No considerations were given to specificity or analyst preference. Yet one of the most difficult tasks in the area of disinfection analytical methods development is comparison testing. It is recommended that a protocol be developed to initiate comparison of the disinfectants. This protocol should include all of the factors delineated in the "Ideal Method" and should be undertaken in both laboratory controlled conditions and at selected water treatment plants around the country.

Chlorine Chemistry.

Clearly, the conversion to moles, equivalents, or normality from units of mg/L (as Cl_2) or mg/L (as other oxidants) can easily be confused (and confusing). Our recommendation is that all oxidizing agents be reported in molar units (M) and, if necessary, in mg/L of that oxidizing agent as measured (i.e. mg/L (as Cl_2) or mg/L (as ClO_2^-) or mg/L (as ClO_3^-). Furthermore, we recommend that oxidizing equivalents per mole of oxidant be reported to minimize additional potential confusion. For example, when ClO_2 is reduced to ClO_2^- , this corresponds to one equivalent/mole; on the other hand, when ClO_2 is reduced to Cl^- , this corresponds to five equivalents/mole. A summary of molecular weights and oxidizing equivalents for the various chlorine species, oxychlorine species and ozone is given in Table II.

TABLE II. EQUIVALENT WEIGHTS FOR CALCULATING CONCENTRATIONS ON THE BASIS OF MASS.

Species	Molecular Weight g/mol	Electrons Transferred	Equivalent Weight g/eq
Chlorine	70.906	2	35.453
Monochloramine	51.476	2	25.738
Dichloramine	85.921	4	21.480
Trichloramine	120.366	6	20.061
Chlorine dioxide	67.452	1	67.452
Chlorine dioxide	67.452	5	13.490
Chlorite ion	67.452	4	16.863
Chlorate ion	83.451	6	13.909
Ozone	47.998	2	23.999
Ozone	47.998	6	8.000

Several mechanisms have been proposed for the decomposition of dichloramine, but the complete mechanism at the breakpoint has not been resolved. Clearly, the chemistry is complicated and varies markedly with solution composition. A detailed understanding of the specific reactions involved requires a detailed knowledge of the concentration of all chloramine species in the system.

Nitrogen-containing organic compounds may be present in surface water and ground-water. Because of analytical complexities, very few detailed studies have been undertaken to determine the individual compounds present and the concentration at which they exist. Kjeldahl nitrogen analysis is used frequently, but this does not provide any detailed information with regard to individual compounds. The area of organic nitrogen and the determination of specific compounds in natural waters is one of the increasing interest and requires considerably more research in characterization and methods development.

Ultraviolet Methods.

In general, because the molar absorptivities are quite low for chlorine and chloramine species, ultraviolet methods are not considered useful in routine monitoring of chlorine residuals. In addition to the low molar absorptivities, there is often background absorbance that may interfere with the measurement in various natural waters. However, these measurements are of use in standardizing the chlorine species in distilled waters and are often used in experimental work

related to chlorine speciation. This method does have considerable potential for the determination of relatively high concentrations of halogens, particularly in relatively clean water. This method might find use in monitoring chlorine species in water treatment plants. However, with a more elaborate multiwavelength spectrophotometer and computer-controlled spectral analysis, it might be possible to analyze several halogens simultaneously.

It is also possible that additional methods using permeable membranes could be developed for the simultaneous determination of chlorine species in aqueous solution. Additional work is necessary in this area. Although the molar absorptivities of the species is not of a magnitude as to lend it to the routine determination of the dilute (less than 10^{-5} M) chlorine and chlorine-ammonia species, it is potentially helpful in determining the concentration of standard solutions. Absorption spectrophotometric analysis has and will continue to be very important in the area of chlorine chemistry. It can be used in the unambiguous determination of relatively high concentrations of the species in relatively pure water.

Continuous Amperometric Titration Method.

Interferences appear to be reduced using the continuous amperometric method because the reagents are added to the sample just prior to contacting the indicating electrode. Thus, when compared to the amperometric titration, the amount of interference by iodate ion, bromate ion, copper(II), iron(III), and manganese(IV) is reduced by approximately one-tenth. No reports appear to be available in the literature on the determination of mixed oxidants using the amperometric method. Such experiments need to be carried out. In addition, few experiments have been reported which clearly demonstrate that the electrodes remain uncontaminated for drinking water or waste water systems. In the absence of such comparisons, the accuracy of any electrode procedure may be questionable.

However, the amperometric titration determination of chlorine species remains the standard for routine laboratory measurements. Given proper analyst training and experience, the commercially available instrumentation is sensitive and precise. This method should remain as the method for laboratory use and accuracy comparisons. It requires more analyst experience than colorimetric methods, but can be relied on to give very accurate and precise measurements. It should be noted that care must be exercised when using one titrator for the measurement of both free and combined chlorine. Small quantities of iodide ion can lead to errors when differentiating between free and combined chlorine. Careful rinsing with chlorine demand free water (CDFW) is a must! Additional development of automated back-titration equipment with the goal of lowering the limit of detection and improving the reproducibility would be highly beneficial.

Iodometric Titration Method.

The iodometric titration is useful for determining high concentrations of total chlorine. The most useful range is 1 mg/L (as Cl_2) or greater. It is a common oxidation-reduction titration analytical method and provides a reference procedure for total chlorine. Although not necessarily used routinely, most laboratories use it as a reference method and it is not likely ever to be eliminated from use.

Colorimetric Methods.

It is reported in Standard Methods (13) that nitrogen trichloride can be measured using the DPD method; however, the method has not been confirmed by independent investigations and should be used only as a qualitative method. Additional research is necessary to determine the effectiveness of the DPD method for nitrogen trichloride. The effect of the presence of mercuric chloride in the reagents for minimizing the breakthrough of monochloramine into the free chlorine reading with the DPD method has been shown. It is very important that the addition of mercuric chloride to the buffer be followed to minimize the direct reaction of monochloramine with DPD. This phenomenon is not thoroughly understood. This effect should be studied more thoroughly and the principle may be applicable to all of the colorimetric methods.

The use of thioacetamide was evaluated for monochloramine (using DPD-Steadifac). It was shown under these conditions to eliminate any positive interference in the free residual measurement. These results are not as yet understood, but the implication is that the chemistry of oxidation is different for monochloramine and free chlorine. These results suggest that more work is necessary to better define the reactions involved, and this may lead to a more usable analytical procedure. This procedure is recommended for use in waters that are suspected to be relatively high in combined chlorine.

The DPD-Ethyl Acetate Extraction Procedure is a modification of the DPD chemistry. The method is based on the oxidation of iodide ion by active chlorine followed by extraction of the iodine species into ethyl acetate. This procedural modification may be of use in the determination of total residual chlorine in both the field and laboratory. Additional work is necessary before it can be used to any great extent. It does not appear to offer substantial advantages to the already well tested colorimetric method for laboratory measurements.

The DPD methods have become the most widely used procedures for the measurement of chlorine. This is not likely to change. The DPD color reagent, in liquid form, has been shown to be quite unstable and is not recommended for use. It is sensitive to oxidation by oxygen and thus requires a control measurement. Clearly, it is better to use dry reagents.

Leuco Crystal Violet, LCV.

No studies have been reported that examine the interference of chlorine dioxide and/or ozone in the LCV method. It is anticipated that these oxidants would interfere in the method, and studies should be conducted to quantify these potential interferents.

Syringaldazine; FACTS.

A study using syringaldazine in a continuous method to differentiate free from combine chlorine has been reported. It was concluded that it could be used and was useful in controlling free chlorination. Further work would have to be conducted to use this or any colorimetric method in continuous analyzers.

Chemiluminescence.

Several papers have appeared that detail the reaction of hydrogen peroxide and hypochlorous acid and the resulting chemiluminescence. The mechanism has been relatively well established and the chemiluminescence is thought to occur as a result of the formation of singlet oxygen. The light emitted is red (635 nm), and occurs most readily in alkaline solution. This reaction is rather insensitive to low concentrations and is not suitable for the determination of hypochlorous acid in aqueous solution. However, the studies that have been reported can serve as a guide for those interested in pursuing other methods for the determination of hypochlorous acid by chemiluminescence. It is not sensitive enough to be considered as an analytical method for chlorine in water treatment.

A study has been reported that details the use of luminol for the measurement of hypochlorite ion. The optimum pH for analysis was between 9.0 and 11.0. Luminol also has been used for the determination of hydrogen peroxide. 4,5,6,7,-tetramethoxyluminol is 30 % more sensitive than luminol. Either of these compounds may be more sensitive in the determination of free chlorine. As these compounds have not been tried it appears that additional studies are necessary. From the limited data available, it appears that this reaction has considerable promise as an analytical method. It may very well be the most sensitive method to date.

It is reported that lophine, in a reaction with hypochlorite ion, produces light. Very few details were given in the study for this reaction. It appears that lophine also may be good as a chemiluminescence reaction system for free chlorine. Additional work should be undertaken to better characterize the details of this reaction.

Luminol and some of its derivatives, or lophine, may be well suited for the very sensitive measurements of chlorine species. Additional research should be undertaken to develop the use of chemiluminescence for use in the determination of chlorine in water. The potential exists for rapid, simple, and specific methods for chlorine and possibly other oxidants. With the advent of fiber optic sensors and their application in chemiluminescence methods, this technology will be important in the future.

Fluorescence.

The use of rhodamine B has been reported as a low level fluorometric method for the determination of bromine. This method is qualitatively specific for bromine, although chlorine will react to decrease the fluorescence. The advantage of this method is that it is capable of determining oxidants at very low concentrations. This method could be applied to chlorine analysis by first using the free chlorine to oxidize the bromide ion to bromine, an irreversible reaction, followed by the determination of bromine. This method was not developed fully and very little work has been undertaken since the first publication. It does appear to have considerable potential and future research in the area of methods development should not exclude additional work on this fluorometric procedure.

Other Electrode Methods.

Additional studies are required to better understand the limitations of membrane electrode methods. It appears that they may have prominent roles to play in chlorine residual measurements in the future.

In a series of experiments carried out for the determination of free chlorine in tap water, it was observed that there was a statistically significant difference between the results of the amperometric titration and the membrane electrodes. It was thought to be a problem in the membrane electrodes. However, on reconsideration, it is possible that the electrodes were actually giving a free chlorine reading and the amperometric titration was reading the sum of free and organically combined chlorine. The study was conducted on water which is relatively high in organic nitrogen. It is possible that considerable chlorine is present as organically combined chlorine and interferes in the amperometric titration procedure, but does not interfere with the membrane electrode measurements. This question must be resolved. Carefully designed experiments to explicitly resolve these differences would be most appropriate.

There have been no reports of experiments using bare-electrode amperometric analyzers where other oxidants such as chlorine dioxide, chlorite ion, chlorate ion or ozone have been tested with the bare-electrode. Additional studies are required to expand these bare-electrode amperometric studies to quantitate interferences with oxidants other than those tested, and to expand to other natural waters.

Since the accuracy of the potentiometric electrodes is affected, if temperature corrections are not used, it is recommended that temperature be either controlled or measured simultaneously. Additional independent measurements of accuracy should be undertaken for the potentiometric electrodes.

It appears that the potentiometric electrode can be used for the determination of total residual oxidant. It is suitable for continuous measurements and appears to give results that are acceptable when compared to the amperometric titrator.

General Summary and Recommendations for Chlorine.

In comparing all of the methods to the "Ideal Method" we find that none come very close to our ideal standard. Continued development of the various methods will, however, come closer and closer to the ideal.

For the present, the amperometric titration techniques will remain the laboratory standard used for the basis of comparisons of accuracy. These methods, with proper precautions can differentiate between the common inorganic chlorine/chlorine ammonia species, and in general suffer from as few interferences as any of the methods.

Of the three common colorimetric procedures, DPD, LCV, and FACTS, the DPD is by far the most commonly used method. From the available literature it is clear that the DPD procedure has a number of weaknesses. In particular, the colored product is a free radical which limits the stability of the colored reaction product. The direct reaction with monochloramine, to form a product identical

to the reaction with free chlorine, is also a drawback. This problem can be reduced by the addition of thioacetamide. Liquid reagent instability precludes their use in most cases; care should be taken to determine blanks frequently.

The present LCV method that appears in Standard Methods (13) is outdated and has been substantially improved upon by Whittle and Lapteff (14). This method allows for the differentiation of the common free and combined inorganic chlorine species. However, because only one comparison study has been conducted, additional collaborative testing is recommended.

The FACTS test procedure appears to be very useful for the determination of free chlorine in the presence of relatively high concentrations of combined inorganic chlorine. A severe drawback of the FACTS test procedure is the insolubility of the syringaldazine in either 2-propanol or water. This leads to difficulties in reagent preparation, and presumably to the color stability problem encountered at the higher concentrations of chlorine (greater than 6 - 8 mg/L (as Cl₂)). Although a method for the use of the FACTS test for total chlorine has been reported, it should be tested further.

Electrode methods have been developed employing several different concepts. The membrane electrodes appear to have potential as specific methods for hypochlorous acid. Common interferences are other nonionized molecules such as chlorine dioxide and ozone. Potentiometric electrodes for the determination of total chlorine are improving in both detection limit and stability. These electrodes appear to have promise in the area of process control. Their inclusion as methods for routine use in the laboratory and field is warranted.

Both fluorescence and chemiluminescence methods also show promise for the specific determination of free chlorine at very low concentrations. Within this area of spectrofluorometric methods, there is considerable work yet to be initiated. Continued development work is warranted and recommended in this promising area.

From the review of analytical procedures for the determination of chlorine in aqueous solution, it is readily apparent that only a few of the methods are used routinely. Nevertheless, there is certain to be a continued interest in developing new and better methods of analysis. We would strongly recommend that new methods be presented in terms of the "Ideal Method" and that whenever possible, comparisons with real samples and interlaboratory comparisons be made.

Flow injection analytical techniques are becoming very common. Continued development should lead to the automation of many colorimetric and fluorometric analytical methods for the measurement of free and combined chlorine and its various species in water. With the current emphasis on automation, the methods that are to be developed and those already developed can readily exceed present standards of accuracy and precision. Automation will also lead to operator independent methods and should lead to improvements in process control and monitoring.

Chlorine Analytical Methods Comparative Studies.

The reader is cautioned against accepting the results of any or all of the above tests without some reservations. Where possible we have tried to add com-

ments, parenthetically, based upon our knowledge of the field. It is very important in reviewing data from comparison tests that the analyst be aware of the objectives of the comparison testing. For example, a test may be judged unacceptable because of an unacceptable lower limit of detection that is beyond the need for concern for other investigators.

In general when testing several test procedures it is important to identify the objective of the testing. Equally important is the use of the data. In reporting the results of the above tests, it should be kept in mind that many manufacturers of chemicals for analytical methods and Test Kits change their procedures as a result of the testing. The concerned analyst needs to determine if the results are still valid. This change is not necessarily applicable to other studies where the chemistry of an analytical method is examined. In general, the more the test studies chemistry and not merely the test procedures, the more applicable the results are for future reference.

Another area of confusion concerns precision and accuracy. An analytical method may be judged acceptable based on the precision of the results, while the same method may give poor accuracy. These statistical parameters are separate and must be tested using different experimental designs. Comparisons with the "Ideal Method" would require that both be at acceptable levels.

In general, there is a lack of comprehensive studies to better understand the chemistry associated with the individual test procedures. Investigations of this nature are necessary on a continuing basis, because of the advances in analytical instrumentation and our continued improvements in understanding the details of the underlying chemistry.

Chlorine Dioxide Analytical Methods.

The iodometric method is a questionable method even for carefully controlled research laboratory chlorine dioxide standards. In real samples where a large number of potential interferences can exist, the method is destined to produce erroneous results. Newer, more species specific methods are better choices.

Any method which determines concentrations by difference is potentially inaccurate and subject to large accumulative errors--both in terms of accuracy and precision. The subtraction of two large numbers to produce a small number means that the errors associated with those large numbers are propagated to the small number. The result in many cases is that the error is larger than the smaller number, therefore, giving meaningless information. Methods such as this, which obtain values by differences, should be avoided.

The DPD method uses the difference method in the evaluation of concentrations. The direct measurement of species by means of a more reliable and accurate method to determine chlorine dioxide is needed. The same questions raised about the DPD method for chlorine also apply here.

Ultraviolet spectrophotometry, utilizing continuous flow automated methods, has a great potential for accurate and precise measurements with the added advantage of ease of operation and high sample throughput. Flow injection analysis methods (FIA) should be carefully evaluated against existing methods for accuracy and precision. The method should be field tested and the potential

problem of membrane reliability should be evaluated for long term operations.

Additional bench studies using continuous flow methods with chemiluminescence detection must be carried out. The superior selectivity of this method needs to be utilized. Comparison lab testing and field study should be carried out.

Chlorite/Chlorate Ion Analytical Methods.

The iodometric/ampereometric methods are indirect determinations of chlorite ion and cannot be recommended. The DPD method for chlorite ion can not be recommended because it is unreliable.

The iodometric sequential methods appear to be very workable on samples containing greater than 1 mg/L chlorite ion or chlorate ion with good precision and accuracy resulting. The method requires considerable operator skill and experience to obtain good precision and accuracy for samples containing less than 1 mg/L chlorite ion or chlorate ion. The method should be field tested with other methods using both high and low ratios of chlorate ion to chlorite ion. The method should be used with caution on low level samples of drinking water and/or wastewater, although direct methods requiring less specialized skills are preferred.

Interlaboratory comparisons should be carried out for the modified iodometric method for the direct analysis of chlorite ion and chlorate ion. The detailed effects of various potential interferences need to be evaluated.

The argentometric titration method is to be recommended only for relatively high concentrations of oxy-chlorine species (10-100 mg/L) but may be very useful in establishing inter-laboratory bench mark comparisons at these high concentration ranges. No such comparisons are currently available.

A highly precise, automated FIA method for low level chlorate ion needs to be developed possibly using various masking agents such as glycine, oxalic acid, malonic acid, and nitrite ion to initially remove other possible oxy-halogen interfering species. The method appears to be very promising in that it can be used to directly determine low level chlorate ion concentrations.

Difficulties With Ozone Measurements: Need For Ideal Method.

As a consequence of the nature of ozone, its continuous self-decomposition, volatility from solution, and the reaction of ozone and its decomposition products with many organic and inorganic contaminants in water, the determination of dissolved residual ozone is very difficult. A detailed knowledge of the mechanism of aqueous ozone decomposition and the potential role of the various highly reactive intermediates, is imperative in order to accurately evaluate the analytical methods (15). In this context it should be noted that most ozone methods are modifications of chlorine residual methods which determine total oxidants in the solution. Therefore, ozone decomposition products such as hydrogen peroxide and the like are also measured.

Iodometry can be used as an example of the difficulties encountered in making aqueous ozone measurements (16). Iodide ion is oxidized to iodine by ozone in an unbuffered potassium iodide solution. The pH then is adjusted to

with sulfuric acid and the liberated iodine is titrated with sodium thiosulfate to a starch end point. The ozone/iodine stoichiometry for this reaction has been found to range from 0.65 to 1.5. Factors affecting the stoichiometry include: pH, buffer composition, buffer concentration, iodide ion concentration, sampling techniques, and reaction time. The pH during the initial ozone/iodide ion reaction and the pH during the iodine determination have been shown to markedly alter the ozone/iodine stoichiometry. The formation of iodate ion and hydrogen peroxide have been implicated specifically as factors affecting the ozone/iodine stoichiometry (17). Modifications in the iodine determination include changes in end point detection, pH, and back-titration techniques. None of these modifications has been demonstrated to be totally satisfactory.

The biggest difficulty in interpreting the existing ozone literature is that no one method has been accepted as the Reference Method. Therefore, comparison between several different methods can create false conclusions about the accuracy of the methods. The method most often used for comparative purposes in the research laboratory is UV measurement of ozone at 260 nm. Even with this method there is apparent confusion over the molar absorptivity for aqueous ozone, with the values ranging from 2900 to 3600 M⁻¹cm⁻¹ (16).

All analytical methods reported, particularly those of early vintage, should be reevaluated, considering the recent information about oxidative by-products from ozone decomposition and the ozonation process itself. Some of these factors may not have been considered during development of the original analytical procedures. Certainly, more detailed information and comparisons should be available. Because of the difficulties of establishing a reliable Reference Method we propose that the existing and future methods be compared against an "Ideal Method". This "Ideal Method" would incorporate all of the characteristics that are desired for an ozone method, taking into account all other potential interferences, decomposition products, and samples originating from various sources. Finally, automation, while not an absolute necessity, can add to the selectivity and ideal nature of a method for ozone determination.

Ozone Measurement: Gas Phase.

The many uses of ozonation in the treatment of drinking water are controlled by monitoring a number of parameters. Dissolved residual ozone is only one of these parameters, and its measurement controls only disinfection conducted after filtration, but before addition of a residual disinfectant for the distribution system. However, it is very clear that the cost, efficiency, safety and improvements in design of ozone water purification systems is extremely dependent on the accurate determination of gas phase ozone. Therefore, analytical methods must be developed that will accurately measure ozone in the gas phase and residual ozone in the aqueous phase. At this point it is unrealistic to believe that one single method will be acceptable for both sample matrices.

Iodometry, UV absorption and chemiluminescence are the three most common methods employed for gas phase measurements (16). Each of these has been applied to determine the amount of ozone present in generator exit gases, when stripped from solution to the gas phase, or the amount of ozone in a connector exhaust gas.

These techniques of monitoring concentrations in contactor exhaust gases are quite promising as a method of controlling the production of adequate quantities of ozone. This provides considerable savings in electrical energy costs for ozone generation. Direct inter-comparisons of the various gas phase measurement techniques are needed in order to evaluate accuracy.

Determination of stripped ozone in the gaseous state was reported in the 16th Edition of Standard Methods (13) for measuring ozone dissolved in water. However, in addition to the procedure being subject to the same limitations of UV absorption and chemiluminescence procedures in aqueous solution, the effects of the gas stripping process itself must be taken into consideration.

Although the iodometric stripping/aqueous absorption method has been approved in Standard Methods (13), we question the accuracy of the method. All evidence would suggest that the method is problematic. Even though the impurities are substantially left behind by the stripping, the actual procedure and the continual decomposition of ozone does introduce inaccuracies into this method. This method can be used as a relative measure of ozone for control purposes.

This basic stripping approach followed by absorption in aqueous solution (and colorimetric measurement) may deserve to be studied further. However, the biggest potential problem appears to be that at high concentrations of ozone the colorimetric compounds may react by a mechanism different from that used for residual ozone measurements. Research should be concentrated on the reagents that have already exhibited ozone selectivity.

Iodometry (Aqueous Phase).

If the performance of ozone in a specific treatment application is not dependent only on the ozone, but is instead a collective function of its reactive decomposition products as well, then iodometry can give a representative and reproducible reading of the total oxidants. For example, most European drinking water treatment plants employing ozonation as the primary disinfectant, have relied on iodometric measurements as the basis for insuring adequate disinfection, attaining a residual "ozone" level of 0.4 mg/L in the first contact chamber and maintaining this level for at least four minutes).

However, it is now abundantly clear that the 0.4 mg/L value is a measure of the amount of total oxidants present, and not necessarily ozone alone. Therefore, either the absolute level of ozone required to attain the expected degree of disinfection is lower than 0.4 mg/L over the required period of time, or some of the decomposition/oxidation products formed upon ozonation also have disinfecting properties, or both. Clearly, detailed experiments need to be carried out to demonstrate the efficacy of disinfection by the decomposition products of ozone. Similar efficacy data for ozone decomposition products could be developed for other uses of ozone (e.g., chemical oxidation) when measurement of residual ozone levels must be made to control the process. Such data would help to justify the continued use of iodometry to measure "total oxidants", rather than only ozone.

Historically, iodometry has been used as the reference method for determining ozone, and against which other analytical procedures have been

"standardized". It is now quite clear that because of its lack of selectivity, the use of iodometry should be limited to that of only a control procedure. In terms of ozonation processes, measurement-for control purposes-of the production rate of ozone generators and bacterial disinfection/viral inactivation may be based upon iodometry, provided the user recognizes the many limitations of the method. The reevaluation of this method must be carried out with the specific goal being to define when the method is reliable and the situations where it is not accurate.

Many authors have tactfully pointed out the many disadvantages of iodometry, leaving it to the reader to decide whether or not to use the procedure. In a detailed comparison of eight analytical methods for the determination of residual ozone it was concluded (16):

"No iodometric method is recommended for the determination of ozone in aqueous solution because of the unreliability of the method and because of the difficulty of the comparison of results obtained with minor modifications in the iodometric method itself."

Arsenic(III) Direct Oxidation.

In the direct oxidation of arsenic(III), ozone reacts with inorganic arsenic(III) at pH 4-7, the pH is adjusted to 6.5-7 and the excess arsenic(III) species is back-titrated with standard iodine to a starch end point. Values for residual ozone determined by the arsenic direct oxidation method and by the indigo method agreed within 6% of the UV values. The primary advantages of the arsenic direct oxidation procedure are minimal interferences, good precision in the hands of experienced operators, and apparently good overall accuracy. This procedure continues to be recommended along with the indigo method. Additional comparisons of this method should be made with the indigo method under various conditions.

Syringaldazine, FACTS.

The FACTS procedure, which was developed for the selective determination of free available chlorine (hypochlorous acid + hypochlorite ion) in the presence of combined chlorine (chloramines), has been adapted for the determination of residual ozone (19). In this procedure, an aqueous solution of ozone is added to a solution of potassium iodide, and the liberated iodine is added to a 2-propanol solution of syringaldazine at pH 6.6. The resulting color is measured spectrophotometrically at 530 nm.

The FACTS procedure has the major advantage of providing a spectrophotometric procedure for the determination of ozone. However, the major limitations of the FACTS method are still those of the iodometric procedure. Due to the observed changes in slope and intercept which are problems caused by the interferences, self-decomposition of ozone, and stoichiometry, this method could be reviewed in order to fully evaluate its potential usefulness. However, considering the other colorimetric methods that are available further development of the FACTS method does not seem to give any promise of the improved selectivity that is needed.

N,N-Diethyl-p-phenylenediamine, DPD.

The DPD procedure is based on the ozone oxidation of iodide ion present in excess phosphate buffer at pH 6.4 to produce iodine, which then oxidizes the DPD cation to a pink Wurster cation which is measured spectrophotometrically, or titrated. The interferences include all oxidants capable of oxidizing iodide ion to iodine, including ozone decomposition products, halogens, and manganese oxides (20).

One advantage of the DPD method is that determinations can be made by ferrous ammonium sulfate (FAS) titrimetry, spectrophotometrically or by a color comparator. Ozone concentrations of less than or equal to 2 mg/L can be determined colorimetrically. Clearly, the procedure requires the difference of differences and is limited by the same factors which limit iodometry, specifically the presence of materials which can oxidize iodide ion to iodine.

Although evaluation of this procedure versus the standard ultraviolet and indigo procedures would seem to be necessary to make a more educated decision about the continued use or abandonment of this method, the recommendation is that other colorimetric methods are considerably more reliable than DPD. Therefore development or testing is neither recommended nor considered necessary at this time.

Indigo Trisulfonate.

The indigo method is subject to fewer interferences than most colorimetric methods and fewer interferences than all iodometric procedures (21-23). At pH 2, chlorite, chlorate, and perchlorate ions, and hydrogen peroxide do not decolorize Indigo Reagent when observed within a few hours and when the concentrations of the interferences are within a factor of 10 of that of the ozone to be determined.

Ozone decomposition products and the products of ozonolysis of organic solutes do not appear to interfere. However, chlorine, bromine, and iodine do cause some interference, as do the oxidized forms of manganese. The addition of malonic acid to the samples will mask the interference of chlorine.

For the Indigo Trisulfonate Method, it should be noted that when the ultraviolet absorption method is used to standardize the indigo method (or any method) for ozone, the choice of molar absorptivity is very critical. It is recommended that the equations of Hoigne continue to be used since they are based on a molar absorptivity of $2950 \text{ M}^{-1}\text{cm}^{-1}$. If and when a different value for molar absorptivity is reported and confirmed, the (calibration) equations would have to be appropriately changed. In this manner, all current measurements using the indigo method would continue to be comparable.

The advantages of the indigo procedure is that it is based on a measure of discoloration which is rapid and stoichiometric. This analytical procedure is recommended for use over any other procedure for the determination of residual ozone. Its primary attributes are its sensitivity, selectivity, accuracy, precision, speed, and simplicity of operation.

The gas diffusion flow injection analysis (GD-FIA) procedure eliminates the interference of oxidized forms of manganese, and markedly reduces the interference of chlorine (24). Other than interference of chlorine which can be reduced to zero by addition of malonic acid, there are no known interferences to the determination of ozone by this GD-FIA procedure using the indigo method.

The primary advantages of the GD-FIA procedure are its accuracy, selectivity, lack of interferences, reproducibility, and rapidity. Thus, the method is well suited for laboratory research studies and for use as an automated analytical procedure.

More studies should be conducted with specific gas-permeable membranes, particularly with respect to repeated and/or continuous exposure to ozone solutions. The use of FIA equipment in a process control environment also must be evaluated. The GD-FIA indigo procedure might well be adopted as the analytical method of choice.

o-Tolidine

The o-tolidine method (addition of 1-2 drops of o-tolidine solution to ozone-containing water to develop the yellow color) is very simple, and easily adapted to field color comparators, suitable for unskilled analysts. However, this advantage cannot compensate for the lack of quantitation of the method, nor for the carcinogenicity of the reagent (o-tolidine). The recommendation is to abandon this method.

Carmine Indigo.

The carmine indigo procedure has been used in Canadian water works plants for the past 15 years. The ozone containing water is titrated with a solution of carmine indigo until a faint blue color persists indicating that all of the ozone has been destroyed. Specific interferences are unknown, but any oxidant capable of decolorizing the carmine indigo dye most likely will interfere.

Effects of interferences should be determined, as should precision, accuracy, and effects of reagent storage and pH. The method should be studied in direct comparison with other methods, such as the indigo and UV absorption methods. Automation of this method could lead to improved selectivity for ozone.

Amperometry.

With bare electrode amperometers, either the solution or the electrode is rotated to establish a diffusion layer, and the electrical current measured is directly proportional to the concentration of dissolved oxidant (25). Commercial amperometric analyzers give satisfactory results provided there is no oxidant other than ozone present in the sample. In many situations they provide adequate monitoring of total oxidant. The bare electrode system has good sensitivity, and is applicable as a continuous nonselective monitor for ozone. When other oxidants such as chlorine, chlorine dioxide, bromine, and iodine are present, the technique has difficulties. The exact nature and magnitude of these interferences requires additional research.

Due to the accumulation of surface impurities at the electrode surfaces, all bare amperometric electrode systems are subject to loss of sensitivity with use. With uncovered electrode surfaces, fouling has been observed to be a significant problem as was the case in earlier tests with oxygen electrodes. Additionally, the response is influenced by numerous surface-active agents and also halogens and oxygen.

An improvement in the development of amperometric methods for ozone analysis has been the application of gas-permeable membranes for increasing selectivity and preventing electrode fouling (26-27). These Teflon membrane electrodes exhibit less than 2% interference (in terms of current response) from bromine, hypobromous acid, chlorine dioxide, hydrogen peroxide, nitrogen trichloride, and hypochlorous acid (26-27).

This type of amperometric membrane sensor needs to be developed further based on the exhibited selectivities. The most disturbing attribute is the temperature dependence. If different membranes could maintain selectivity while minimizing the temperature effect, this type of sensor could become highly recommended.

The application of positive voltage potentials and the use of polymeric membranes that are selectively permeable to gases has enhanced the opportunity for selective measurement of ozone. This is a very significant improvement over bare amperometric electrodes as well as most older colorimetric/spectrophotometric and titrimetric methods. With an applied voltage of +0.6 V (vs SCE) at the cathode, only the most powerful oxidizing agents can overcome the "resistance" of this anodic voltage and cause electron flow cathodically through the electrochemical circuit. This general approach should continue to be used in future electrochemical developments.

Other Electrochemical Methods.

In the differential pulse polarography procedure (DPP), a predetermined amount of phenylarsine oxide (PAO) is added in excess to an ozone solution to reduce the levels of dissolved ozone present. Excess PAO then is measured quantitatively by pulse polarography. The DPP method may under some circumstances be useful in the research laboratory. The prospects of its use in the plant or field are not as promising since a higher degree of operator skill is required.

Potentiometry involves the cathodic reduction of dissolved ozone. The diffusion-limiting current measured is proportional to the concentration of ozone in the water. Further evaluation of potentiometric systems may be in order. However, the fundamental problems of electrode fouling must be addressed. Perhaps a combination of membranes and potentiometric detection would produce a promising system for ozone determinations. The system appears to have modest potential for development.

Ultraviolet Measurements.

Ultraviolet absorption measurements also can be used for residual aqueous ozone at 258-260 nm. There is uncertainty with respect to the molar absorptivity for aqueous ozone. In the literature, values ranging from 2900 to

3600 M⁻¹cm⁻¹ are reported. This uncertainty in the molar absorptivity is critical to the future use and calibration uses of the UV methods. Clearly, further work to verify this value is strongly recommended.

If the molar absorptivity for ozone is known unambiguously, UV absorption is in principle an absolute method for the determination of ozone, which is not dependent upon calibration or standardization against other analytical methods. Therefore, it can be used for calibration of other analytical methods for ozone. It is specific to the determination of ozone, and is applicable to measurement in gaseous and aqueous phases.

Physical Methods.

The calorimetric method is based on the enthalpy of the catalyzed decomposition of ozone ($\Delta H = 144.41$ KJ/mole). The calorimetric determination of ozone is calibration-independent. The technique is specific to the determination of molecular ozone, but is applicable to measurement only in the gas phase. However, the higher the concentration of ozone in the gas phase, the more accurate the method appears to be, since a greater temperature difference is observed. Potential interferences have not been reported.

The method has been shown to agree with iodometric and UV absorption procedures, particularly for the measurement of ozone in the gases exiting ozone generators. Therefore, the procedure can be used to monitor applied ozone dosages. Additional detailed interlaboratory comparisons need to be carried out.

The isothermal differential pressure procedure is based on the generation of an increased number of gas molecules during the UV destruction of ozone at constant temperature. When this reaction is carried out isothermally in a closed vessel, the increase in pressure of the contained gas is proportional to the ozone concentration. In principle, this procedure achieves a totally physical ozone measurement without requiring checks such as the stored molar absorptivity. Various automated instrumental checks such as the stored molar absorptivity, the age of the UV light source, the zero point reading, measurement of the flow of the test gas and the flushing gas, and the reading of the diagnostic display are possible.

No specific comparisons are reported. However, in principle it appears that this physical method is the best candidate for calibrating the gas phase ozone instruments currently being used for ozonation control. As long as pure oxygen is used for ozone generation this method would be free of interferences and would be subject only to strict temperature control of the measurement cell. Further study of this system would be necessary before it could be recommended for further consideration.

General Summary and Recommendations for Ozone.

In comparing all the methods to the "Ideal Method" we find that none come close to our ideal standard. Continued development of the various selective methods will, however, come closer and closer to the ideal.

In terms of gas phase measurements, none of the existing methods can be recommended for accurate determinations of ozone. If a relative value of the ozone concentration is needed for control purposes, most of the methods reported could be applicable.

The accurate determination of ozone in the aqueous phase is complicated by the decomposition of ozone, its reactivity to the other species present, and the by-products of the ozonation reactions. Most current methods were developed without a clear knowledge of the associated ozone chemistry. Therefore most of the methods are unacceptable or cannot be recommended. In particular, no iodometric based chemistry is acceptable for the determination of aqueous ozone. Indigo trisulfonate and arsenic(III) direct oxidation are acceptable methods. Amperometry continues to improve -- especially as an automated control method.

The stripping techniques have some merit in terms of improved ozone selectivity. However, automated chemical systems such as flow injection analysis offer considerably more promise. The current GD-FIA indigo procedure is superior for residual ozone measurements due to its selectivity for ozone.

The most important aspect of any potential new or improved ozone analytical method will be speed of analysis and selectivity of the detection system for only ozone. As a point of comparison, we strongly recommend that all future and existing methods be compared against the "Ideal Method".

LITERATURE

1. Symons, J.M.; et al. "Ozone, Chlorine Dioxide and Chloramines as Alternatives to Chlorine for Disinfection of Drinking Water" in Water Chlorination: Environmental Impact and Health Effects, Vol. 2; Jolley, R.L.; Gorchev, H. and Hamilton, D.H., Jr., Editors. (Ann Arbor, MI: Ann Arbor Science Publishers, Inc., 1979) pp. 555-560 and Complete Report entitled "State of the Art ..." (Cincinnati, OH: U.S. EPA, November, 1977), 84 pp.
2. Proceedings of Seminar on "The Design and Operation of Drinking Water Facilities Using Ozone or Chlorine Dioxide", Rice, R.G., Editor. (Dedham, MA: New England Water Works Assoc., 1979).
3. Miller, G.W.; Rice, R.G.; Robson, C.M.; Scullin, R.L.; Kühn, W. and Wolf, H., "An Assessment of Ozone and Chlorine Dioxide Technologies for Treatment of Municipal Water Supplies", U.S. Environmental Protection Agency, EPA Project Report, EPA-600/2-78/018, 1978, 571 pp.
4. Miltner, R.J. "Measurement of Chlorine Dioxide and Related Products", in Proceedings of the Water Quality Technological Conference, (Denver, CO: American Water Works Assoc., 1976), pp. 1-11.

5. Gordon, G. "Improved Methods of Analysis for Chlorate, Chlorite, and Hypochlorite Ions at the Sub-mg/L Level", U.S. Environmental Protection Agency, EPA Technical Report, EPA-600/4-85/079, October, 1985. 35 p. and Presented at AWWA WQTC, in Proc. AWWA Water Quality Technology Conference, December, Nashville, TN, 1982, pp. 175-189.
6. Aieta, E.M.; Roberts, P.V. "Chlorine Dioxide Chemistry: Generation and Residual Analysis" in Chemistry in Water Reuse, Vol. 1, Cooper, W.J., Editor (Ann Arbor, MI: Ann Arbor Science Publishers, Inc., 1981), pp. 429-452.
7. Hoigné, J.; Bader, H. "Bestimmung von Ozon und Chlordioxid in Wasser mit der Indigo-Methode" ("Determination of Ozone and Chlorine Dioxide in Water With the Indigo Method"), Vom Wasser, 1980, 25, 261-280.
8. Gilbert, E.; Hoigné, J. "Messung von Ozon in Wasserwerken: Vergleich der DPD- und Indigo-Methode" ("Ozone Measurement in Water Treatment Plants: Comparison of the DPD and Indigo Methods"), GW-Wasser/Abwasser, 1983, 124, 527-531.
9. Schalekamp, M. "European Alternatives and Experience" in Proceedings of the National (Canadian) Conference on Critical Issues in Drinking Water Quality, (Ottawa, Ontario, Canada: Federation of Associations on Canadian Environment, 1984), pp. 140-169.
10. Ikeda, Y.; Tang, T-F.; Gordon, G. "Iodometric Method of Determination of Trace Chlorate Ion", Anal. Chem., 1984, 56, 71-73.
11. Emmenegger F.; Gordon, G. "The Rapid Interaction between Sodium Chlorite and Dissolved Chlorine", Inorg. Chem., 1967, 6, 633-635.
12. Aieta, E.M.; Berg, J.D. "A Review of Chlorine Dioxide in Drinking Water Treatment", J. Am. Water Works Assoc., 1986, 78, 62-72.
13. Standard Methods for The Examination of Water and Wastewater, 16th Edition, Greenberg, A.E.; Trussell, R.R.; Clesceri, L.S.; Franson, M.A.H., Editors (Washington, D.C.: American Public Health Assoc., 1985), 1268 pp. and 15th Edition, Greenberg, A.E.; Connors, J.J.; Jenkins, D.; Franson, M.A.H., Editors (Washington, DC: American Public Health Assoc., 1980), 1134 pp.
14. Whittle, G.P.; Lapteff, A., Jr. "New Analytical Techniques for the Study of Water Disinfection" in Chemistry of Water Supply, Treatment, and Distribution, Rubin, A.J., Editor, (Ann Arbor, MI: Ann Arbor Sci. Pub., Inc., 1974), pp. 63-88.
15. Tomiyasu, H.; Fukutomi, H.; Gordon, G. "Kinetics and Mechanism of Ozone Decomposition in Basic Aqueous Solution", Inorg. Chem., 1985, 24, 2962-2966.

16. Grunwell, J.; Benga, J.; Cohen, H.; Gordon, G. "A Detailed Comparison of Analytical Methods for Residual Ozone Measurement", *Ozone Sci. Eng.*, 1983, 1, 203-223.
17. Flamm, D.L.; Anderson, S.A. "Iodate Formation and Decomposition in Iodometric Analysis of Ozone", *Environ. Sci. Technol.*, 1975, 2, 660-663.
18. Rehme, K.A.; Puzak, J.C.; Beard, M.E.; Smith, C.F.; Paur, R.J. "Evaluation of Ozone Calibration Procedures", U.S. Environmental Protection Agency, EPA Project Summary, EPA-600/S4-80-050, February, 1980, 277 pp.
19. Liebermann, J., Jr.; Roscher, N.M.; Meier, E.P.; Cooper, W.J. Development of the FACTS Procedure for Combined Forms of Chlorine and Ozone in Aqueous Solutions", *Environ. Sci. Technol.*, 1980, 14, 1395-1400.
20. Palin, A.T.; Derreumaux, A. "Détermination de l'Ozone Résiduel dans l'eau" ("Determination of Ozone Residual in Water"), *L'Eau et l'Industrie*, 1977, 12, 57-60.
21. Bader, H.; Hoigné, J. "Colorimetric Method for the Measurement of Aqueous Ozone Based on the Decolorization of Indigo Derivatives", in Ozonization Manual for Water and Wastewater Treatment, Masschelein, W.J., Editor, (New York, NY: John Wiley & Sons, 1982), pp. 169-172.
22. Bader, H.; Hoigné, J. "Determination of Ozone in Water by the Indigo Method", *Water Research* 1981, 15, 449-456.
23. Bader, H.; Hoigné, J. "Determination of Ozone in Water by the Indigo Method; A Submitted Standard Method", *Ozone: Science and Eng.*, 1982, 4, 169-176.
24. Straka, M.R.; Gordon, G.; Pacey, G.E. "Residual Aqueous Ozone Determination by Gas Diffusion Flow Injection Analysis", *Anal. Chem.*, 1985, 57, 1799-1803.
25. Masschelein, W.J. "Continuous Amperometric Residual Ozone Analysis in the Tailfer (Brussels, Belgium) Plant", in Ozonization Manual for Water and Wastewater Treatment, Masschelein, W.J., Editor, (New York, NY: John Wiley & Sons, 1982), pp. 187-188.
26. Stanley, J.H.; Johnson, J.D. "Amperometric Membrane Electrode for Measurement of Ozone in Water", *Anal. Chem.*, 1979, 51, 2144-2147.
27. Stanley, J.W.; Johnson, J.D. "Analysis of Ozone in Aqueous Solution", in Handbook of Ozone Technology and Applications, Vol. 1, Rice, R.G. and Netzer, A., Editors (Ann Arbor, MI: Ann Arbor Sci. Pub., Inc., 1982), pp. 255-276.

A GUIDE FOR EFFICIENT USE OF THIS REPORT (AND A BRIEF GLOSSARY OF TERMS)

This Report contains a very detailed review of all disinfectant residual measurement methods. The Executive Summary is intended to give readers a brief overview of the advantages and disadvantages of each method. To that end, Table I (Characteristics and Comparisons of Analytical Methods) has been included to summarize each of our findings and to recommend possible directions for future research. In addition, Table II (Equivalent Weights for Calculating Concentrations on the Basis of Mass) describes the equivalent weights of each of the disinfection species in terms of the actual reactions involved in the disinfection process.

Each chapter contains individual recommendations following the discussion of the method. A summary of all of the recommendations is also given at the end of each chapter. Additional help is given by means of an alphabetical Index containing more than 2500 individual terms. Specific cross referencing for all recommendations can be found in the Index either under the "recommendation", or, in terms of the subject of the numbered recommendation itself.

The term Referee Method is used to describe appropriate comparisons with existing methods and Standard Methods refers to a specifically recommended method. The Index should be an additional aid to finding the details of specific methods.

In this context, it should be noted that the individual literature citations are specific to each individual chapter -- and are either numbered individually within chapters 2 and 3, or alphabetically sequenced within chapters 4 and 5.

Chapter 4 (Indexed Reference Citations) has been included in this report in order to assist readers in locating particular papers of interest. The 48 categories for chlorine, chloramines, and the oxy-chlorine species, along with the additional 60 categories for ozone, should make the task of finding individual papers of interest considerably less cumbersome. Papers which describe several methods have been included in each of the appropriate categories. All together, the 1,400 references cited in Chapters 1-3 number more than 2,000 individual citations when distributed in the indexed form of Chapter 4.

Chapter 5 is an alphabetical listing of the individual references citations. Finally, a detailed Index has been included in order to assist readers in locating subjects of specific interest. We hope the readers will find these additional chapters as useful as have we in preparing this report.

A brief Glossary follows on the next page in order to assist readers in the various specialized terms and abbreviations used in this report. For additional terms, the reader is referred to the Index.

GLOSSARY

- Accuracy -- the ability to determine the correct concentration
- BAKI -- boric acid buffered potassium iodide method for ozone
- Breakpoint -- the inorganic reaction of chlorine with ammonia nitrogen
- CDFW -- chlorine demand free water
- Combined Chlorine -- inorganic and organic chloramines
- Detection Limit -- a signal that is 3 times the noise level of the system
- DOC -- dissolved organic carbon
- DPD -- (N,N-diethyl-p-phenylenediamine)
- FACTS -- free available chlorine test with syringaldazine
- FIA -- flow injection analysis, an automated analysis procedure
- Free Chlorine -- the species, $\text{Cl}_2 + \text{HOCl} + \text{OCl}^-$
- KI -- potassium iodide method for ozone
- LCV -- leuco crystal violet
- mL -- milliliter(s), standard unit of volume
- Molar Absorptivity (ϵ) reported in units of $\text{M}^{-1}\text{cm}^{-1}$
- NBKI -- neutral buffered potassium iodide method for ozone
- Precision -- how well the method reproducibly measures the same concentration
- Reactive Intermediate -- species such as O_2^- , HO_2^- , HO_2 , OH , O_3^- , etc.
- Referee Method -- the method against which a working method is compared
- Sensitivity -- the change in signal per unit concentration [i.e. Amps/mol]
- Standard Methods -- the book, Standard Methods for the Examination of Water and Wastewater published by APHA, AWWA, and WPCF
- THM's -- trihalomethanes
- Total Chlorine -- the combination of Free Chlorine and Combined Chlorine
- TOC -- total organic carbon
- TOX -- total organic halogen

APPENDIX E
INACTIVATIONS ACHIEVED
BY VARIOUS DISINFECTANTS

TABLE E-1
CT VALUES FOR INACTIVATION
OF GIARDIA CYSTS BY FREE CHLORINE
AT 0.5 C OR LOWER (1)

CHLORINE CONCENTRATION (mg/L)	pH <= 6						pH = 6.5						pH = 7.0						pH = 7.5					
	Log Inactivations						Log Inactivations						Log Inactivations						Log Inactivations					
	0.5	1.0	1.5	2.0	2.5	3.0	0.5	1.0	1.5	2.0	2.5	3.0	0.5	1.0	1.5	2.0	2.5	3.0	0.5	1.0	1.5	2.0	2.5	3.0
<=0.4	23	46	69	91	114	137	27	54	82	109	136	163	33	65	98	130	163	195	40	79	119	158	198	237
0.6	24	47	71	94	118	141	28	56	84	112	140	168	33	67	100	133	167	200	40	80	120	159	199	239
0.8	24	48	73	97	121	145	29	57	86	115	143	172	34	68	103	137	171	205	41	82	123	164	205	246
1	25	49	74	99	123	148	29	59	88	117	147	176	35	70	105	140	175	210	42	84	127	169	211	253
1.2	25	51	76	101	127	152	30	60	90	120	150	180	36	72	108	143	179	215	43	86	130	173	216	259
1.4	26	52	78	103	129	155	31	61	92	123	153	184	37	74	111	147	184	221	44	89	133	177	222	266
1.6	26	52	79	105	131	157	32	63	95	126	158	189	38	75	113	151	188	226	46	91	137	182	228	273
1.8	27	54	81	108	135	162	32	64	97	129	161	193	39	77	116	154	193	231	47	93	140	186	233	279
2	28	55	83	110	138	165	33	66	99	131	164	197	39	79	118	157	197	236	48	95	143	191	238	286
2.2	28	56	85	113	141	169	34	67	101	134	168	201	40	81	121	161	202	242	50	99	149	198	248	297
2.4	29	57	86	115	143	172	34	68	103	137	171	205	41	82	124	165	206	247	50	99	149	199	248	298
2.6	29	58	88	117	146	175	35	70	105	139	174	209	42	84	126	168	210	252	51	101	152	203	253	304
2.8	30	59	89	119	148	178	36	71	107	142	178	213	43	86	129	171	214	257	52	103	155	207	258	310
3	30	60	91	121	151	181	36	72	109	145	181	217	44	87	131	174	218	261	53	105	158	211	263	316
CHLORINE CONCENTRATION (mg/L)	pH = 8.0						pH = 8.5						pH <= 9.0											
	Log Inactivations						Log Inactivations						Log Inactivations											
	0.5	1.0	1.5	2.0	2.5	3.0	0.5	1.0	1.5	2.0	2.5	3.0	0.5	1.0	1.5	2.0	2.5	3.0						
<=0.4	46	92	139	185	231	277	55	110	165	219	274	329	65	130	195	260	325	390						
0.6	48	95	143	191	238	286	57	114	171	228	285	342	68	136	204	271	339	407						
0.8	49	98	148	197	246	295	59	118	177	236	295	354	70	141	211	281	352	422						
1	51	101	152	203	253	304	61	122	183	243	304	365	73	146	219	291	364	437						
1.2	52	104	157	209	261	313	63	125	188	251	313	376	75	150	226	301	376	451						
1.4	54	107	161	214	268	321	65	129	194	258	323	387	77	155	232	309	387	464						
1.6	55	110	165	219	274	329	66	132	199	265	331	397	80	159	239	318	398	477						
1.8	56	113	169	225	282	338	68	136	204	271	339	407	82	163	245	326	408	489						
2	58	115	173	231	288	346	70	139	209	278	348	417	83	167	250	333	417	500						
2.2	59	118	177	235	294	353	71	142	213	284	355	426	85	170	256	341	426	511						
2.4	60	120	181	241	301	361	73	145	218	290	363	435	87	174	261	348	435	522						
2.6	61	123	184	245	307	368	74	148	222	296	370	444	89	178	267	355	444	533						
2.8	63	125	188	250	313	375	75	151	226	301	377	452	91	181	272	362	453	543						
3	64	127	191	255	318	382	77	153	230	307	383	460	92	184	276	368	460	552						

Notes:

(1) CT = CT for 3-log inactivation

TABLE E-2
CT VALUES FOR INACTIVATION
OF GIARDIA CYSTS BY FREE CHLORINE
AT 5 C (1)

CHLORINE CONCENTRATION (mg/L)	pH <= 6 Log Inactivations						pH = 6.5 Log Inactivations						pH = 7.0 Log Inactivations						pH = 7.5 Log Inactivations					
	0.5	1.0	1.5	2.0	2.5	3.0	0.5	1.0	1.5	2.0	2.5	3.0	0.5	1.0	1.5	2.0	2.5	3.0	0.5	1.0	1.5	2.0	2.5	3.0
<=0.4	16	32	49	65	81	97	20	39	59	78	98	117	23	46	70	93	116	139	28	55	83	111	138	166
0.6	17	33	50	67	83	100	20	40	60	80	100	120	24	48	72	95	119	143	29	57	86	114	143	171
0.8	17	34	52	69	86	103	20	41	61	81	102	122	24	49	73	97	122	146	29	58	88	117	146	175
1	18	35	53	70	88	105	21	42	63	83	104	125	25	50	75	99	124	149	30	60	90	119	149	179
1.2	18	36	54	71	89	107	21	42	64	85	106	127	25	51	76	101	127	152	31	61	92	122	153	183
1.4	18	36	55	73	91	109	22	43	65	87	108	130	26	52	78	103	129	155	31	62	94	125	156	187
1.6	19	37	56	74	93	111	22	44	66	88	110	132	26	53	79	105	132	158	32	64	96	128	160	192
1.8	19	38	57	76	95	114	23	45	68	90	113	135	27	54	81	108	135	162	33	65	98	131	163	196
2	19	39	58	77	97	116	23	46	69	92	115	138	28	55	83	110	138	165	33	67	100	133	167	200
2.2	20	39	59	79	98	118	23	47	70	93	117	140	28	56	85	113	141	169	34	68	102	136	170	204
2.4	20	40	60	80	100	120	24	48	72	95	119	143	29	57	86	115	143	172	35	70	105	139	174	209
2.6	20	41	61	81	102	122	24	49	73	97	122	146	29	58	88	117	146	175	36	71	107	142	178	213
2.8	21	41	62	83	103	124	25	49	74	99	123	148	30	59	89	119	148	178	36	72	109	145	181	217
3	21	42	63	84	105	126	25	50	76	101	126	151	30	61	91	121	152	182	37	74	111	147	184	221
CHLORINE CONCENTRATION (mg/L)	pH = 8.0 Log Inactivations						pH = 8.5 Log Inactivations						pH <= 9.0 Log Inactivations											
	0.5	1.0	1.5	2.0	2.5	3.0	0.5	1.0	1.5	2.0	2.5	3.0	0.5	1.0	1.5	2.0	2.5	3.0						
<=0.4	33	66	99	132	165	198	39	79	118	157	197	236	47	93	140	186	233	279						
0.6	34	68	102	136	170	204	41	81	122	163	203	244	49	97	146	194	243	291						
0.8	35	70	105	140	175	210	42	84	126	168	210	252	50	100	151	201	251	301						
1	36	72	108	144	180	216	43	87	130	173	217	260	52	104	156	208	260	312						
1.2	37	74	111	147	184	221	45	89	134	178	223	267	53	107	160	213	267	320						
1.4	38	76	114	151	189	227	46	91	137	183	228	274	55	110	165	219	274	329						
1.6	39	77	116	155	193	232	47	94	141	187	234	281	56	112	169	225	281	337						
1.8	40	79	119	159	198	238	48	96	144	191	239	287	58	115	173	230	288	345						
2	41	81	122	162	203	243	49	98	147	196	245	294	59	118	177	235	294	353						
2.2	41	83	124	165	207	248	50	100	150	200	250	300	60	120	181	241	301	361						
2.4	42	84	127	169	211	253	51	102	153	204	255	306	61	123	184	245	307	368						
2.6	43	86	129	172	215	258	52	104	156	208	260	312	63	125	188	250	313	375						
2.8	44	88	132	175	219	263	53	106	159	212	265	318	64	127	191	255	318	382						
3	45	89	134	179	223	268	54	108	162	216	270	324	65	130	195	259	324	389						

Notes:

(1) CT = CT for 3-log inactivation

**TABLE E-3
CT VALUES FOR INACTIVATION
OF GIARDIA CYSTS BY FREE CHLORINE
AT 10 C (1)**

CHLORINE CONCENTRATION (mg/L)	pH <= 6 Log Inactivations						pH = 6.5 Log Inactivations						pH = 7.0 Log Inactivations						pH = 7.5 Log Inactivations					
	0.5	1.0	1.5	2.0	2.5	3.0	0.5	1.0	1.5	2.0	2.5	3.0	0.5	1.0	1.5	2.0	2.5	3.0	0.5	1.0	1.5	2.0	2.5	3.0
<=0.4	12	24	37	49	61	73	15	29	44	59	73	88	17	35	52	69	87	104	21	42	63	83	104	125
0.6	13	25	38	50	63	75	15	30	45	60	75	90	18	36	54	71	89	107	21	43	64	85	107	128
0.8	13	26	39	52	65	78	15	31	46	61	77	92	18	37	55	73	92	110	22	44	66	87	109	131
1	13	26	40	53	66	79	16	31	47	63	78	94	19	37	56	75	93	112	22	45	67	89	112	134
1.2	13	27	40	53	67	80	16	32	48	63	79	95	19	38	57	76	95	114	23	46	69	91	114	137
1.4	14	27	41	55	68	82	16	33	49	65	82	98	19	39	58	77	97	116	23	47	70	93	117	140
1.6	14	28	42	55	69	83	17	33	50	66	83	99	20	40	60	79	99	119	24	48	72	96	120	144
1.8	14	29	43	57	72	86	17	34	51	67	84	101	20	41	61	81	102	122	25	49	74	98	123	147
2	15	29	44	58	73	87	17	35	52	69	87	104	21	41	62	83	103	124	25	50	75	100	125	150
2.2	15	30	45	59	74	89	18	35	53	70	88	105	21	42	64	85	106	127	26	51	77	102	128	153
2.4	15	30	45	60	75	90	18	36	54	71	89	107	22	43	65	86	108	129	26	52	79	105	131	157
2.6	15	31	46	61	77	92	18	37	55	73	92	110	22	44	66	87	109	131	27	53	80	107	133	160
2.8	16	31	47	62	78	93	19	37	56	74	93	111	22	45	67	89	112	134	27	54	82	109	136	163
3	16	32	48	63	79	95	19	38	57	75	94	113	23	46	69	91	114	137	28	55	83	111	138	166
CHLORINE CONCENTRATION (mg/L)	pH = 8.0 Log Inactivations						pH = 8.5 Log Inactivations						pH <= 9.0 Log Inactivations											
	0.5	1.0	1.5	2.0	2.5	3.0	0.5	1.0	1.5	2.0	2.5	3.0	0.5	1.0	1.5	2.0	2.5	3.0						
<=0.4	25	50	75	99	124	149	30	59	89	118	148	177	35	70	105	139	174	209						
0.6	26	51	77	102	128	153	31	61	92	122	153	183	36	73	109	145	182	218						
0.8	26	53	79	105	132	158	32	63	95	126	158	189	38	75	113	151	188	226						
1	27	54	81	108	135	162	33	65	98	130	163	195	39	78	117	156	195	234						
1.2	28	55	83	111	138	166	33	67	100	133	167	200	40	80	120	160	200	240						
1.4	28	57	85	113	142	170	34	69	103	137	172	206	41	82	124	165	206	247						
1.6	29	58	87	116	145	174	35	70	106	141	176	211	42	84	127	169	211	253						
1.8	30	60	90	119	149	179	36	72	108	143	179	215	43	86	130	173	216	259						
2	30	61	91	121	152	182	37	74	111	147	184	221	44	88	133	177	221	265						
2.2	31	62	93	124	155	186	38	75	113	150	188	225	45	90	136	181	226	271						
2.4	32	63	95	127	158	190	38	77	115	153	192	230	46	92	138	184	230	276						
2.6	32	65	97	129	162	194	39	78	117	156	195	234	47	94	141	187	234	281						
2.8	33	66	99	131	164	197	40	80	120	159	199	239	48	96	144	191	239	287						
3	34	67	101	134	168	201	41	81	122	162	203	243	49	97	146	195	243	292						

Notes:

(1) CT = CT for 3-log inactivation

**TABLE E-4
CT VALUES FOR INACTIVATION
OF GIARDIA CYSTS BY FREE CHLORINE
AT 15 C (1)**

CHLORINE CONCENTRATION (mg/L)	pH <= 6 Log Inactivations						pH = 6.5 Log Inactivations						pH = 7.0 Log Inactivations						pH = 7.5 Log Inactivations					
	0.5	1.0	1.5	2.0	2.5	3.0	0.5	1.0	1.5	2.0	2.5	3.0	0.5	1.0	1.5	2.0	2.5	3.0	0.5	1.0	1.5	2.0	2.5	3.0
<=0.4	8	16	25	33	41	49	10	20	30	39	49	59	12	23	35	47	58	70	14	28	42	55	69	83
0.6	8	17	25	33	42	50	10	20	30	40	50	60	12	24	36	48	60	72	14	29	43	57	72	86
0.8	9	17	26	35	43	52	10	20	31	41	51	61	12	24	37	49	61	73	15	29	44	59	73	88
1	9	18	27	35	44	53	11	21	32	42	53	63	13	25	38	50	63	75	15	30	45	60	75	90
1.2	9	18	27	36	45	54	11	21	32	43	53	64	13	25	38	51	63	76	15	31	46	61	77	92
1.4	9	18	28	37	46	55	11	22	33	43	54	65	13	26	39	52	65	78	16	31	47	63	78	94
1.6	9	19	28	37	47	56	11	22	33	44	55	66	13	26	40	53	66	79	16	32	48	64	80	96
1.8	10	19	29	38	48	57	11	23	34	45	57	68	14	27	41	54	68	81	16	33	49	65	82	98
2	10	19	29	39	48	58	12	23	35	46	58	69	14	28	42	55	69	83	17	33	50	67	83	100
2.2	10	20	30	39	49	59	12	23	35	47	58	70	14	28	43	57	71	85	17	34	51	68	85	102
2.4	10	20	30	40	50	60	12	24	36	48	60	72	14	29	43	57	72	86	18	35	53	70	88	105
2.6	10	20	31	41	51	61	12	24	37	49	61	73	15	29	44	59	73	88	18	36	54	71	89	107
2.8	10	21	31	41	52	62	12	25	37	49	62	74	15	30	45	59	74	89	18	36	55	73	91	109
3	11	21	32	42	53	63	13	25	38	51	63	76	15	30	46	61	76	91	19	37	56	74	93	111
CHLORINE CONCENTRATION (mg/L)	pH = 8.0 Log Inactivations						pH = 8.5 Log Inactivations						pH <= 9.0 Log Inactivations											
	0.5	1.0	1.5	2.0	2.5	3.0	0.5	1.0	1.5	2.0	2.5	3.0	0.5	1.0	1.5	2.0	2.5	3.0						
<=0.4	17	33	50	66	83	99	20	39	59	79	98	118	23	47	70	93	117	140						
0.6	17	34	51	68	85	102	20	41	61	81	102	122	24	49	73	97	122	146						
0.8	18	35	53	70	88	105	21	42	63	84	105	126	25	50	76	101	126	151						
1	18	36	54	72	90	108	22	43	65	87	108	130	26	52	78	104	130	156						
1.2	19	37	56	74	93	111	22	45	67	89	112	134	27	53	80	107	133	160						
1.4	19	38	57	76	95	114	23	46	69	91	114	137	28	55	83	110	138	165						
1.6	19	39	58	77	97	116	24	47	71	94	118	141	28	56	85	113	141	169						
1.8	20	40	60	79	99	119	24	48	72	96	120	144	29	58	87	115	144	173						
2	20	41	61	81	102	122	25	49	74	98	123	147	30	59	89	118	148	177						
2.2	21	41	62	83	103	124	25	50	75	100	125	150	30	60	91	121	151	181						
2.4	21	42	64	85	106	127	26	51	77	102	128	153	31	61	92	123	153	184						
2.6	22	43	65	86	108	129	26	52	78	104	130	156	31	63	94	125	157	188						
2.8	22	44	66	88	110	132	27	53	80	106	133	159	32	64	96	127	159	191						
3	22	45	67	89	112	134	27	54	81	108	135	162	33	65	98	130	163	195						

Notes:

(1) CT = CT for 3-log inactivation

**TABLE E-5
CT VALUES FOR INACTIVATION
OF GIARDIA CYSTS BY FREE CHLORINE
AT 20 C (1)**

CHLORINE CONCENTRATION (mg/L)	pH <= 6 Log Inactivations						pH = 6.5 Log Inactivations						pH = 7.0 Log Inactivations						pH = 7.5 Log Inactivations					
	0.5	1.0	1.5	2.0	2.5	3.0	0.5	1.0	1.5	2.0	2.5	3.0	0.5	1.0	1.5	2.0	2.5	3.0	0.5	1.0	1.5	2.0	2.5	3.0
<=0.4	6	12	18	24	30	36	7	15	22	29	37	44	9	17	26	35	43	52	10	21	31	41	52	62
0.6	6	13	19	25	32	38	8	15	23	30	38	45	9	18	27	36	45	54	11	21	32	43	53	64
0.8	7	13	20	26	33	39	8	15	23	31	38	46	9	18	28	37	46	55	11	22	33	44	55	66
1	7	13	20	26	33	39	8	16	24	31	39	47	9	19	28	37	47	56	11	22	34	45	56	67
1.2	7	13	20	27	33	40	8	16	24	32	40	48	10	19	29	38	48	57	12	23	35	46	58	69
1.4	7	14	21	27	34	41	8	16	25	33	41	49	10	19	29	39	48	58	12	23	35	47	58	70
1.6	7	14	21	28	35	42	8	17	25	33	42	50	10	20	30	39	49	59	12	24	36	48	60	72
1.8	7	14	22	29	36	43	9	17	26	34	43	51	10	20	31	41	51	61	12	25	37	49	62	74
2	7	15	22	29	37	44	9	17	26	35	43	52	10	21	31	41	52	62	13	25	38	50	63	75
2.2	7	15	22	29	37	44	9	18	27	35	44	53	11	21	32	42	53	63	13	26	39	51	64	77
2.4	8	15	23	30	38	45	9	18	27	36	45	54	11	22	33	43	54	65	13	26	39	52	65	78
2.6	8	15	23	31	38	46	9	18	28	37	46	55	11	22	33	44	55	66	13	27	40	53	67	80
2.8	8	16	24	31	39	47	9	19	28	37	47	56	11	22	34	45	56	67	14	27	41	54	68	81
3	8	16	24	31	39	47	10	19	29	38	48	57	11	23	34	45	57	68	14	28	42	55	69	83
CHLORINE CONCENTRATION (mg/L)	pH = 8.0 Log Inactivations						pH = 8.5 Log Inactivations						pH <= 9.0 Log Inactivations											
	0.5	1.0	1.5	2.0	2.5	3.0	0.5	1.0	1.5	2.0	2.5	3.0	0.5	1.0	1.5	2.0	2.5	3.0						
<=0.4	12	25	37	49	62	74	15	30	45	59	74	89	18	35	53	70	88	105						
0.6	13	26	39	51	64	77	15	31	46	61	77	92	18	36	55	73	91	109						
0.8	13	26	40	53	66	79	16	32	48	63	79	95	19	38	57	75	94	113						
1	14	27	41	54	68	81	16	33	49	65	82	98	20	39	59	78	98	117						
1.2	14	28	42	55	69	83	17	33	50	67	83	100	20	40	60	80	100	120						
1.4	14	28	43	57	71	85	17	34	52	69	86	103	21	41	62	82	103	123						
1.6	15	29	44	58	73	87	18	35	53	70	88	105	21	42	63	84	105	126						
1.8	15	30	45	59	74	89	18	36	54	72	90	108	22	43	65	86	108	129						
2	15	30	46	61	76	91	18	37	55	73	92	110	22	44	66	88	110	132						
2.2	16	31	47	62	78	93	19	38	57	75	94	113	23	45	68	90	113	135						
2.4	16	32	48	63	79	95	19	38	58	77	96	115	23	46	69	92	115	138						
2.6	16	32	49	65	81	97	20	39	59	78	98	117	24	47	71	94	118	141						
2.8	17	33	50	66	83	99	20	40	60	79	99	119	24	48	72	95	119	143						
3	17	34	51	67	84	101	20	41	61	81	102	122	24	49	73	97	122	146						

Notes:

(1) CT = CT for 3-log inactivation

99.9

TABLE E-6
CT VALUES FOR INACTIVATION
OF GIARDIA CYSTS BY FREE CHLORINE
AT 25 C (1)

CHLORINE CONCENTRATION (mg/L)	pH <= 6 Log Inactivations						pH = 6.5 Log Inactivations						pH = 7.0 Log Inactivations						pH = 7.5 Log Inactivations					
	0.5	1.0	1.5	2.0	2.5	3.0	0.5	1.0	1.5	2.0	2.5	3.0	0.5	1.0	1.5	2.0	2.5	3.0	0.5	1.0	1.5	2.0	2.5	3.0
<=0.4	4	8	12	16	20	24	5	10	15	19	24	29	6	12	18	23	29	35	7	14	21	28	35	42
0.6	4	8	13	17	21	25	5	10	15	20	25	30	6	12	18	24	30	36	7	14	22	29	36	43
0.8	4	9	13	17	22	26	5	10	16	21	26	31	6	12	19	25	31	37	7	15	22	29	37	44
1	4	9	13	17	22	26	5	10	16	21	26	31	6	12	19	25	31	37	8	15	23	30	38	45
1.2	5	9	14	18	23	27	5	11	16	21	27	32	6	13	19	25	32	38	8	15	23	31	38	46
1.4	5	9	14	18	23	27	6	11	17	22	28	33	7	13	20	26	33	39	8	16	24	31	39	47
1.6	5	9	14	19	23	28	6	11	17	22	28	33	7	13	20	27	33	40	8	16	24	32	40	48
1.8	5	10	15	19	24	29	6	11	17	23	28	34	7	14	21	27	34	41	8	16	25	33	41	49
2	5	10	15	19	24	29	6	12	18	23	29	35	7	14	21	27	34	41	8	17	25	33	42	50
2.2	5	10	15	20	25	30	6	12	18	23	29	35	7	14	21	28	35	42	9	17	26	34	43	51
2.4	5	10	15	20	25	30	6	12	18	24	30	36	7	14	22	29	36	43	9	17	26	35	43	52
2.6	5	10	16	21	26	31	6	12	19	25	31	37	7	15	22	29	37	44	9	18	27	35	44	53
2.8	5	10	16	21	26	31	6	12	19	25	31	37	8	15	23	30	38	45	9	18	27	36	45	54
3	5	11	16	21	27	32	6	13	19	25	32	38	8	15	23	31	38	46	9	18	28	37	46	55
CHLORINE CONCENTRATION (mg/L)	pH = 8.0 Log Inactivations						pH = 8.5 Log Inactivations						pH <= 9.0 Log Inactivations											
	0.5	1.0	1.5	2.0	2.5	3.0	0.5	1.0	1.5	2.0	2.5	3.0	0.5	1.0	1.5	2.0	2.5	3.0						
<=0.4	8	17	25	33	42	50	10	20	30	39	49	59	12	23	35	47	58	70						
0.6	9	17	26	34	43	51	10	20	31	41	51	61	12	24	37	49	61	73						
0.8	9	18	27	35	44	53	11	21	32	42	53	63	13	25	38	50	63	75						
1	9	18	27	36	45	54	11	22	33	43	54	65	13	26	39	52	65	78						
1.2	9	18	28	37	46	55	11	22	34	45	56	67	13	27	40	53	67	80						
1.4	10	19	29	38	48	57	12	23	35	46	58	69	14	27	41	55	68	82						
1.6	10	19	29	39	48	58	12	23	35	47	58	70	14	28	42	56	70	84						
1.8	10	20	30	40	50	60	12	24	36	48	60	72	14	29	43	57	72	86						
2	10	20	31	41	51	61	12	25	37	49	62	74	15	29	44	59	73	88						
2.2	10	21	31	41	52	62	13	25	38	50	63	75	15	30	45	60	75	90						
2.4	11	21	32	42	53	63	13	26	39	51	64	77	15	31	46	61	77	92						
2.6	11	22	33	43	54	65	13	26	39	52	65	78	16	31	47	63	78	94						
2.8	11	22	33	44	55	66	13	27	40	53	67	80	16	32	48	64	80	96						
3	11	22	34	45	56	67	14	27	41	54	68	81	16	32	49	65	81	97						

Notes:

(1) CT = CT for 3-log inactivation

TABLE E-7
CT VALUES FOR
INACTIVATION OF VIRUSES BY FREE CHLORINE⁽¹⁾

<u>Temperature (C)</u>	<u>Log Inactivation</u>					
	<u>2.0</u>		<u>3.0</u>		<u>4.0</u>	
	<u>pH</u>		<u>pH</u>		<u>pH</u>	
	<u>6-9</u>	<u>10</u>	<u>6-9</u>	<u>10</u>	<u>6-9</u>	<u>10</u>
0.5	6	45	9	66	12	90
5	4	30	6	44	8	60
10	3	22	4	33	6	45
15	2	15	3	22	4	30
20	1	11	2	16	3	22
25	1	7	1	11	2	15

Notes:

1. Basis for values given in Appendix F.

TABLE E-8
CT VALUES FOR
INACTIVATION OF GIARDIA CYSTS
BY CHLORINE DIOXIDE⁽¹⁾

<u>Inactivation</u>	<u>Temperature (C)</u>					
	<u><=1</u>	<u>5</u>	<u>10</u>	<u>15</u>	<u>20</u>	<u>25</u>
0.5-log	10	4.3	4	3.2	2.5	2
1-log	21	8.7	7.7	6.3	5	3.7
1.5-log	32	13	12	10	7.5	5.5
2-log	42	17	15	13	10	7.3
2.5-log	52	22	19	16	13	9
3-log	63	26	23	19	15	11

Note:

1. Basis for values given in Appendix F.

TABLE E-9
CT VALUES FOR
INACTIVATION OF VIRUSES
BY CHLORINE DIOXIDE pH 6-9⁽¹⁾

Removal	Temperature (C)					
	≤1	5	10	15	20	25
2-log	8.4	5.6	4.2	2.8	2.1	1.4
3-log	25.6	17.1	12.8	8.6	6.4	4.3
4-log	50.1	33.4	25.1	16.7	12.5	8.4

Notes:

1. Basis for values given in Appendix F.

TABLE E-10
CT VALUES FOR
INACTIVATION OF GIARDIA CYSTS
BY OZONE⁽¹⁾

<u>Inactivation</u>	<u>Temperature (C)</u>					
	<u><=1</u>	<u>5</u>	<u>10</u>	<u>15</u>	<u>20</u>	<u>25</u>
0.5-log	0.48	0.32	0.23	0.16	0.12	0.08
1-log	0.97	0.63	0.48	0.32	0.24	0.16
1.5-log	1.5	0.95	0.72	0.48	0.36	0.24
2-log	1.9	1.3	0.95	0.63	0.48	0.32
2.5-log	2.4	1.6	1.2	0.79	0.60	0.40
3-log	2.9	1.9	1.43	0.95	0.72	0.48

Note:

1. Basis for values given in Appendix F.

TABLE E-11
CT VALUES FOR
INACTIVATION OF VIRUSES BY OZONE⁽¹⁾

<u>Inactivation</u>	<u>Temperature (C)</u>					
	<u><=1</u>	<u>5</u>	<u>10</u>	<u>15</u>	<u>20</u>	<u>25</u>
2-log	0.9	0.6	0.5	0.3	0.25	0.15
3-log	1.4	0.9	0.8	0.5	0.4	0.25
4-log	1.8	1.2	1.0	0.6	0.5	0.3

Note:

1. Basis for values given in Appendix F.

TABLE E-12
CT VALUES FOR
INACTIVATION OF GIARDIA CYSTS
BY CHLORAMINE pH 6-9⁽¹⁾

<u>Inactivation</u>	<u>Temperature (C)</u>					
	<u><=1</u>	<u>5</u>	<u>10</u>	<u>15</u>	<u>20</u>	<u>25</u>
0.5-log	635	365	310	250	185	125
1-log	1,270	735	615	500	370	250
1.5-log	1,900	1,100	930	750	550	375
2-log	2,535	1,470	1,230	1,000	735	500
2.5-log	3,170	1,830	1,540	1,250	915	625
3-log	3,800	2,200	1,850	1,500	1,100	750

Note:

1. Basis for values given in Appendix F.

TABLE E-13
CT VALUES FOR
INACTIVATION OF VIRUSES BY CHLORAMINE⁽¹⁾

<u>Inactivation</u>	<u>Temperature (C)</u>					
	<u><=1</u>	<u>5</u>	<u>10</u>	<u>15</u>	<u>20</u>	<u>25</u>
2-log	1,243	857	643	428	321	214
3-log	2,063	1,423	1,067	712	534	356
4-log	2,883	1,988	1,491	994	746	497

Notes:

1. Basis for values given in Appendix F.

TABLE E-14
CT VALUES FOR
INACTIVATION OF VIRUSES BY UV⁽¹⁾

<u>Log Inactivation</u>	
<u>2.0</u>	<u>3.0</u>
21	36

Note:

1. Basis for values given in Appendix F.

APPENDIX F
BASIS FOR CT VALUES

APPENDIX F
BASIS OF CT VALUES

F.1 Inactivation of *Giardia* Cysts

F.1.1 Free Chlorine

The CT values for free chlorine in Tables E-1 through E-6 are based on a statistical analysis (Clark et al., 1988; attached to this appendix), which considered both animal infectivity studies (Hibler et al., 1987) and excystation studies (Jarroll et al., 1981; Rice et al., 1982; Rubin et al., 1988). A multiplicative model was selected to best represent the chemical reactions during the inactivation process. This model was applied to each of the data sets, listed above, and in various combinations. The animal infectivity data were included in all combinations studied. The animal infectivity data was considered essential for inclusion in all the analysis of combined data sets because it included many more data points than the other data sets, all of which represented inactivation levels at 99.99 percent. Because of limitations with the excystation methodology, only data for achieving less than 99.9 percent inactivation was available from such studies.

Statistical analysis supported the choice of combining the Hibler et al. and the Jarroll et al. data (and excluding the Rice et al. (1981) and Rubin et al. (1987) data), to form the best fit model for predicting CT values for different levels of inactivation. As a conservative regulatory strategy, Clark and Regli (1990) (attached at the end of this appendix), recommended that CT values for different levels of inactivation be determined by applying first order kinetics to the 99 percent upper confidence interval of the $CT_{99.99}$ values predicted by the model.

The model was applied using the above strategy as a safety factor, to determine the CT values ranging from 0.5-log to 3-log inactivation at 0.5 and 5 C. CT values for temperatures above 5 C were estimated assuming a twofold decrease for every 10 C. CT values for temperatures at 0.5 C were estimated assuming a 1.5 times increase to CT values at 5 C. This general principle is supported by Hoff (1986). It is important to note that the CT values for free chlorine are sensitive to the residual

concentration, C. For example, at a pH of 7 and a temperature of 10 C, a 3-log Giardia cyst inactivation results from a CT of 107 mg/L-min with a free residual of 0.6 g/L and a CT of 124 mg/L-min with a free residual of 2.0 mg/L.

Application of the model to pHs above 8, up to 9, was considered reasonable because the model is substantially sensitive to pH (e.g., CTs at pH 9 are over three times greater than CTs at pH 6 and over two times greater than CTs at pH 7). At a pH of 9, approximately four percent of the hypochlorous acid fraction of free chlorine is still present. Recent data indicate that in terms of HOCl residuals (versus total free chlorine residuals including HOCl and OCl⁻) the CT products required for inactivation of Giardia muris and Giardia lamblia cysts decrease with increasing pH from 7 to 9 (Leahy et al., 1987; Rubin et al., 1988b). However, with increasing pH, the fraction of free chlorine existing as the weaker oxidant species (OCl⁻) increases. In terms of total free chlorine residuals (i.e., HOCl and OCl⁻) the CT products required for inactivation of Giardia muris cysts increase with increasing pH from 7 to 9 by less than a factor of 2 at concentrations of less than 5.0 mg/L (see Table F-1). Also, the significance of pH on the value of CT products achieving 99 percent inactivation appears to decrease with decreasing temperature and free chlorine concentration. The relative effects of pH, temperature, and chlorine concentration, on inactivation of Giardia muris cysts appears to be the same for Giardia lamblia cysts (Rubin et al., 1988b), although not as much data for Giardia lamblia cysts for high pH and temperature values as for Giardia muris cysts is yet available.

F.1.2 Ozone and Chlorine Dioxide

The CT values for ozone in Table E-10 are based on disinfection studies using in vitro excystation of Giardia lamblia (Wickramanayake, G. B., et al., 1985). CT₉₉ values at 5 C and pH 7 for ozone ranged from 0.46 to 0.64 (disinfectant concentrations ranging from 0.11 to 0.48 mg/L). No CT values were available for other pHs. The highest CT₉₉ value, 0.64, was used as a basis for extrapolation to obtain the CT values at 5 C, assuming first order kinetics and applying a safety factor of 2, e.g., (0.64 X 3/2 X 2 = 1.9). CT values for temperatures

TABLE F-1

**CT VALUES TO ACHIEVE 99 PERCENT
INACTIVATION OF GIARDIA MURIS CYSTS BY FREE CHLORINE**
(Source: Rubin, et al., 1988b)

pH	Temperature (C)	Concentration (mg/L)			
		0.2-0.5	0.5-1.0	1.0-2.0	2.0-5.0
7	1	500	760	1,460	1,200
	15	200	290	360	290
8	1	510	820	1,580	1,300
	15		220		320
9	1	440	1,100	1,300	2,200
	15	310	420	620	760

above 5 C were estimated assuming a twofold decrease for every 10 C. CT values for temperatures at 0.5 C were estimated assuming a 1.5 times increase to CT values at 5 C.

The CT values for chlorine dioxide in Table E-8 are based on disinfection studies using in vitro excystation of Giardia muris CT₉₉ values at pH 7 and 1 C, 5 C, 15 C and 25 C (Leahy, 1985 and Rubin, 1988b). The average CT₉₉ value at each temperature (27.9 at 1 C, 11.8 at 5 C, 8.5 at 15 C, and 4.7 at 25 C) was extrapolated using first order kinetics and multiplied by a safety factor of 1.5 to obtain the CT_{99.9} values, e.g.,

$$\text{at 1 C, } C_{99.9} = 27.9 \times 1.5 \times 1.5 = 63.$$

Because of the limited data available at pHs other than pH 7, the same CT values are specified for all pHs. Although most of the CT₉₉ data were determined at pH 7, it is known that chlorine dioxide is more effective at pH 9. Thus, the CT values in the rule are more conservative for higher pHs than for lower pHs.

A lower safety factor is used for chlorine dioxide than for ozone, because the data was generated using Giardia muris cysts which are more resistant than Giardia lamblia cysts. CT values at other temperatures were estimated, based on the same rule of thumb multipliers assumed for ozone.

A larger safety factor was applied to the ozone and chlorine dioxide data than to the chlorine data because:

- a. Less data were available for ozone and chlorine dioxide than for chlorine;
- b. Data available for ozone and chlorine dioxide, because of the limitations of the excystation procedure, only reflected up to or slightly beyond 99 percent inactivation. Data for chlorine, based on animal infectivity studies rather than excystation procedures, reflected inactivation of 99.99 percent. Extrapolation of data to achieve CT values for 99.9 percent inactivation with ozone and chlorine dioxide, involved greater uncertainty than the direct determination of CT values for 99.9 percent inactivation using chlorine.
- c. The CT values for ozone and chlorine dioxide to achieve 99.9 percent inactivation are feasible to achieve; and
- d. Use of ozone and chlorine dioxide is likely to occur within the plant rather than in the distribution system (versus chlorine and chloramines which are the likely disinfectants

for use in the distribution system). Contact time measurements within the plant will involve greater uncertainty than measurement of contact time in pipelines.

EPA recognizes that the CT values for ozone and chlorine dioxide are based on limited data. Therefore, EPA encourages the generation of additional data in accordance with the protocols provided in Appendix G to determine conditions other than the specified CT values, for providing effective disinfection at a particular system.

F.1.3 Chloramines

The CT values for chloramines in Table E-12 are based on disinfection studies using preformed chloramines and in vitro excystation of Giardia muris (Rubin, 1988). Table F-2 summarizes CT values for achieving 99 percent inactivation of Giardia muris cysts. The highest CT values for achieving 99 percent inactivation at 1 C (2,500) and 5 C (1,430) were each multiplied by 1.5 (i.e., first order kinetics were assumed) to estimate the $CT_{99.9}$ values at 0.5 C and 5 C, respectively, in Table E-12. The $CT_{99.9}$ value of 970 at 15 C was multiplied by 1.5 to estimate the $CT_{99.9}$ value. The highest $CT_{99.9}$ value of 1,500 at 15 C and pH 6 was not used because it appeared anomalous to the other data. Interesting to note is that among the data in Table F-2 the CT values in the lower residual concentration range (<2 mg/L) are higher than those in the higher residual concentration range (2-10 mg/L). This is opposite to the relationship between these variables for free chlorine. For chloramines, residual concentration may have greater influence than contact time on the inactivation of Giardia cysts within the range of chloramine residual concentrations practiced by water utilities (less than 10 mg/L). No safety factor was applied to these data since chloramination, conducted in the field, is more effective than using preformed chloramines. Also, Giardia muris appears to be more resistant than Giardia lamblia to chloramines (Rubin, 1988b).

The protocol in Appendix G can be used to demonstrate if less stringent disinfection conditions than those cited in Table E-12 can achieve comparable levels of inactivation for specific system characteristics.

TABLE F-2

**CT VALUES FOR 99 PERCENT
INACTIVATION OF GIARDIA MURIS CYSTS BY MONOCHLORAMINE***
(Source: Rubin, 1988)

pH	Temperature (C)	Monochloramine Concentration (mg/L)	
		≤0.2	2.0-10.0
6	15	1,500	880
	5	>1,500	>880
	1	>1,500	>880
7	15	>970	970
	5	>970	1,400
	1	2,500	>1,400
8	15	1,000	530
	5	>1,000	1,430
	1	>1,000	1,880
9	15	890	560
	5	>890	>560
	1	>890	>560

*CT values with ">" signs are extrapolated from the known data.

F.2 Inactivation of Viruses

F.2.1 Free Chlorine

CT values for free chlorine are based on data by Sobsey (1988) for inactivation of Hepatitis A virus (HAV), Strain HM175, at pH 6,7,8,9 and 10, chlorine concentrations of 0.5 to 0.2, and a temperature of 5 C, as contained in Table F-3. The highest CT value for the pH range 6-9 for achieving 2, 3, and 4-log inactivation of HAV were multiplied by a safety factor of 3 to obtain the CT values listed in Table E-7. (e.g., the CT value for achieving 4-log inactivation at pHs 6-9 was determined by multiplying $2.55 \times 3 = 7.6 = 8$). The CT values at pH 10 were significantly higher than those for pHs 6-9 and are considered separately. The CT values in Table E-7 for pH 10 also include a safety factor of 3. CT values at temperatures other than 5 C were determined assuming a two fold decrease for every 10 C increase. CT values for inactivating viruses in general are based on HAV data since they give higher CT values than those for inactivation of polio and rotaviruses under similar conditions of pH and temperature (Hoff, 1986).

F.2.2 Chlorine Dioxide

Data by Sobsey (1988) for inactivation of Hepatitis A virus, strain HM 175, by a chlorine dioxide concentration of 0.5 mg/l at pH 6 and 5 C is shown in Table F-4. The CT values in Table E-9 for pHs 6-9 and temperature = 5 C were determined by applying a safety factor of 2 to the average CT values presented in Table F-4 at pH 6. This safety factor is lower than that used to determine CT values for chlorine because chlorine dioxide appears to be significantly more effective at higher pHs and most waters are assumed to have a higher pH than 6.

CT values at temperatures other than 5 C in Table E-9 were determined by applying a twofold decrease for every 10 C increase. The data for pH 9 was not considered because it is very limited and other viruses are more resistant to chlorine dioxide than Hepatitis A is at pH 9. According to Hoff (1986) at a pH of 9 and a temperature of 21 C, a CT of 0.35 provides a 4-log inactivation of poliovirus 1. Applying the same safety factor and rule of thumb multipliers to this data results in a CT

of 2.8 for a 4-log virus inactivation at 0.5°C, in contrast to a CT of 50.1 resulting from the Hepatitis A data at pH 6. Therefore, in order to assure inactivation of Hepatitis A, the higher CT values are needed. Systems with high pHs may wish to demonstrate the effectiveness of chlorine dioxide at lower CT values based on the protocol in Appendix G. Chlorine dioxide is much more effective for inactivating rotavirus and polio virus than it is for inactivating HAV (Hoff 1986).

F.2.3 Chloramines

The CT values in Table E-13 at 5 C were based directly on data by Sobsey (1988) using preformed chloramines at pH 8. No safety factor was applied to the laboratory data since chloramination in the field, where some transient presence of free chlorine would occur, is assumed more effective than preformed chloramines.

HAV is less resistant to preformed chloramines than are other viruses. For example, CTs of 3,800-6,500 were needed for 2-log inactivation of simian rotavirus at pH = 8.0 and temperature = 5 C (Berman and Hoff, 1984). However, these same viruses are very sensitive to free chlorine. CT values ranging from less than 0.025 to 2.16 were required to achieve 99 percent inactivation of rotavirus by free chlorine at pH = 6-10 and temperature = 4-5 C (Hoff, 1986). HAV is more resistant to free chlorine than are rotaviruses.

The CT values in Table E-13 apply for systems using combined chlorine where chlorine is added prior to ammonia in the treatment sequence. This should provide sufficient contact with free chlorine to assure inactivation of rotaviruses. CT values Table E-13 should not be used for estimating the adequacy of disinfection in systems applying preformed chloramines or ammonia ahead of chlorine, since CT values based on HAV inactivation with preformed chloramines may not be adequate for destroying rotaviruses. In systems applying preformed chloramines, it is recommended that inactivation studies as outlined in Appendix G be performed with Bacteriophage MS2 as the indicator virus to determine sufficient CT values. Also, the protocol in Appendix G can be used by systems applying chlorine ahead of ammonia to demonstrate less stringent disinfection conditions than those indicated in Table E-13.

TABLE F-3

CT VALUES FOR INACTIVATION OF HEPATITIS A VIRUS
BY FREE CHLORINE

(Source: Sobsey 1988)

LOG INACTIVATION	pH				
	6	7	8	9	10
2	1.18	0.70	1.00	1.25	19.3
3	1.75	1.07	1.51	1.9	14.6
4	2.33	1.43	2.03	2.55	9.8

TABLE F-4

CT VALUES FOR INACTIVATION OF HEPATITUS A VIRUS
BY CHLORINE DIOXIDE (SOBSEY 1988)

	<u>Experiment No.</u>	<u>ClO₂ Concentration (mg/L)</u>	
		<u>Initial</u>	<u>Average</u>
pH6	1	0.49	0.32
	2	0.50	0.33
	3	0.51	0.36
	4	0.51	0.37
pH9	1	0.5	0.5
	2	0.5	0.5

	<u>Log Inactivation</u>	<u>(min)</u>				<u>CT¹</u>				<u>Average CT</u>
		<u>Experiment No.</u>				<u>Experiment No.</u>				
		1	2	3	4	1	2	3	4	
pH6	2	12	9	5	7	3.8	3.0	1.8	2.6	2.8
	3	30	29	22	20	9.4	9.6	7.9	7.4	8.6
	4	55	59	43	39	17	20	16	14	16.7
pH9	>2.5	0.33	--	--	--	<0.17	--	--	--	<0.17
	>3.6	0.33	--	--	--	<0.17	--	--	--	<0.17

Note:

1. CT values were obtained by multiplying inactivation time by the average concentration shown above for each experiment.

F.2.4 Ozone

No laboratory CT values based on inactivation of HAV virus are yet available for ozone. Based on data from Roy (1982), a mean CT value of 0.2 achieved 2-log inactivation of poliovirus 1 at 5 C and pH 7.2. Much lower CT values are needed to achieve a 2-log inactivation of rotavirus (Vaughn, 1987). No CT values were available for achieving greater than a 2-log inactivation. The CT values in Table E-11 for achieving 2-log inactivation at 5 C were determined by applying a safety factor of 3 to the data from Roy (1982). CT values for 3 and 4-log inactivation were determined by applying first order kinetics and assuming the same safety factor of 3. CT values were adjusted for temperatures other than 5 C by applying a twofold decrease for every 10 C increase. Based on the available data, CT values for ozone disinfection are not strongly dependent on pH. Therefore, data obtained at pH = 7.2 is assumed to apply for pHs in the range of 6.0 to 9.0. However, it should be noted that the maintenance of an ozone residual is affected by pH.

F.2.5 Ultraviolet Light (UV)

The CT values for inactivation of viruses by UV are based on studies by Sobsey (1988) on inactivation of Hepatitis A virus (HAV) by UV. These data were used because HAV has been established as an important cause of waterborne disease. The CT values were derived by applying a safety factor of 3 to the HAV inactivation data. The CT values in Table E-14 are higher than the CT values for UV inactivation of poliovirus 1 and simian rotavirus from previous studies (Chang et al., 1985).

F.2.6 Potassium Permanganate

Potassium permanganate is a commonly used oxidant in water treatment. Preliminary testing by Yahya, et al 1988, indicates that potassium permanganate may contribute to virus inactivation. The test data included in Table F-5 indicates the inactivation of bacteriophage MS-2 using potassium permanganate with a pure water-buffer solution. These data do not include safety factors. It is likely that CT values for actual water treatment processes will differ from these values. This data has only been provided here as an indication of the potential of potassium

TABLE F-5
CT VALUES FOR 2-LOG INACTIVATION
OF MS-2 BACTERIOPHAGE WITH POTASSIUM PERMANGANATE

<u>KMnO₄</u> <u>(mg/L)</u>	<u>pH 6.0</u>	<u>pH 8.0</u>
0.5	27.4 a ⁽¹⁾	26.1 a
1.5	32.0 a	50.9 b
2.0	ND ⁽²⁾	53.5 c
5.0	63.8 a	35.5 c

Notes:

1. Letters indicate different experimental conditions.
2. Not determined.

**THE BASIS FOR GIARDIA C·T VALUES IN THE SURFACE WATER
TREATMENT RULE: INACTIVATION BY CHLORINE**

by

**Robert M. Clark, Director
Drinking Water Research Division
Risk Reduction Engineering Laboratory
Cincinnati, OH 45268**

and

**Stig Regli
Office of Drinking Water
U.S. Environmental Protection Agency
Washington, DC 20460**

**RISK REDUCTION ENGINEERING LABORATORY
OFFICE OF RESEARCH AND DEVELOPMENT
U.S. ENVIRONMENTAL PROTECTION AGENCY
CINCINNATI, OH 45268**

February 1991

THE BASIS FOR GIARDIA C·T VALUES IN THE SURFACE WATER
TREATMENT RULE: INACTIVATION BY CHLORINE

by

Robert M. Clark,^a and Stig Regli^b

INTRODUCTION

The 1986 amendments to the Safe Drinking Water Act (SDWA) require EPA to promulgate primary drinking water regulations (a) specifying criteria under which filtration would be required, (b) requiring disinfection as a treatment technique for all public water systems, and (c) establishing maximum contaminant levels (MCLs) or treatment requirements for control of Giardia lamblia, viruses, Legionella, heterotrophic plate count bacteria, and turbidity. EPA has promulgated treatment technique requirements to fulfill the SDWA requirement for systems using surface waters and ground waters under the direct influence of surface water.¹ Additional regulations specifying disinfection requirements for systems using ground water sources not under the direct influence of surface water will be proposed and promulgated at a later date. This paper presents a model that relates pH, temperature, chlorine concentration, and inactivation level to Giardia inactivation by free chlorine. Because Giardia lamblia is known to be one of the most resistant organisms to disinfection by chlorine found in water, much interest and effort

^aDirector, Drinking Water Research Division, Risk Reduction Engineering Laboratory, 26 W. Martin Luther King Drive, Cincinnati, Ohio 45268

^bUSEPA, Office of Drinking Water, 401 M Street, S.W., Washington, DC 20460

has been devoted to determination of C:t values for Giardia lamblia. The model has been used to predict "C:t" values that have been included as part of EPA's Surface Water Treatment Rule (SWTR).

BACKGROUND

Under the SWTR all community and non-community public water systems using surface water, or ground water under the direct influence of surface water, are required to provide minimum disinfection to control Giardia lamblia, enteric viruses and bacteria.¹ In addition, unless the source water is well protected and meets certain water quality criteria (total or fecal coliforms and turbidity limits), treatment must also include filtration. The treatment provided, in any case, is required to achieve at least 99.9 percent removal and/or inactivation of Giardia lamblia cysts and at least 99.99 percent removal and/or inactivation of viruses (i.e., virus of fecal origin and infectious to humans). Unfiltered systems are required to demonstrate that disinfection alone achieves the minimum performance requirements by monitoring disinfectant residual(s), disinfectant contact time(s), pH (if chlorine is used), and water temperature. These data must be applied to determine if their "C:t" value [the product of disinfectant concentration (mg/L) and disinfectant contact (minutes)] equals or exceeds the C:t values for Giardia lamblia specified in the SWTR.¹ With the exception of chloramines, where ammonia is added prior to chlorine, these C:t values are also adequate to achieve greater than 99.99 percent inactivation of viruses. For filtered systems, states are required to specify the level of disinfection for each system to ensure that their overall treatment achieves at least 99.9 and 99.99 percent removal and/or inactivation of Giardia lamblia cysts and viruses, respectively.¹

In the Guidance Manual to the SWTR, EPA recommends C:t values for

different disinfectants to achieve levels of inactivation for unfiltered systems. Filtered systems will be required to achieve less inactivation than required for unfiltered systems. The percent inactivation that filtered systems should achieve as a function of the filtration technology in place and source water quality conditions is also recommended.²

PROBLEM

The destruction of pathogens by chlorination is dependent on a number of factors, including water temperature, pH, disinfectant contact time, degree of mixing, turbidity, presence of interfering substances, and concentration of chlorine available. The pH has a significant effect on inactivation efficiency because it determines the species of chlorine found in solution, each of which has a different inactivation efficiency.

The impact of temperature on disinfection efficiency is also significant. For Example, Clarke's work in virus destruction by chlorine indicates that contact time must be increased two to three times when the temperature is lowered 10°C.³ Disinfection by chlorination can inactivate Giardia cysts, but only under rigorous conditions. Most recently, Hoff et al. concluded that (1) these cysts are among the most resistant pathogens known, (2) disinfection at low temperatures is especially difficult, and (3) treatment processes prior to disinfection are important.⁴

Typical C·t values for 99 percent inactivation of Giardia lamblia by free chlorine at different temperatures and pH values are shown in Table 1.

TABLE 1. C·T VALUES FOR 99% INACTIVATION OF GIARDIA⁶
LAMBLIA CYSTS BY FREE CHLORINE

Temp (°C)	pH	Disinfectant Concentration (mg/L)	Range		Mean C·t	No. of Experiments
			Time (min)	C·t		
5	6	1.0-8.0	6-47	47-84	65	4
	7	2.0-8.0	7-42	56-152	97	3
	8	2.0-8.0	72-164	72-164	110	3
15	6	2.5-3.0	7	18-21	20	2
	7	2.5-3.0	6-18	18-45	32	2
	8	2.5-3.0	7-21	21-52	37	2
25	6	1.5	< 6	< 9	< 9	1
	7	1.5	< 7	< 10	< 10	1
	8	1.5	< 8	< 12	< 12	1

Jarroll et al., using in vitro excystation to determine cyst viability, showed that greater than 99.8 percent of Giardia lamblia cysts can be killed by exposure to 2.5 mg/L of chlorine for 10 minutes at 15°C and pH 6, or after 60 minutes at pH 7 or 8. At 5°C, exposure to 2 mg/L of chlorine killed at least 99.8 percent of all cysts at pH 6 and 7 after 60 minutes.⁵ While it required 8 mg/L to kill the same percentage of cysts at pH 6 and 7 after 10 minutes, it required 8 mg/L to inactivate cysts to the same level at pH 8 after 30 minutes. Inactivation rates decreased at lower temperatures and at higher pH values as indicated by the higher C·t values.

Because of the obvious interactions among these variables it is essential that a model be developed for predicting C·t values under the various conditions that may exist in drinking water systems.

OBJECTIVE

As indicated, many factors influence Giardia lamblia reaction kinetics. The objective of the study described in this paper therefore is to develop an equation that will relate C:t values for Giardia inactivated by chlorine to such factors as pH, temperature, level of inactivation and chlorine concentration. As mentioned previously, this equation ultimately provided the values presented in the SWTR and associated Guidance Manual for disinfection of Giardia lamblia by free chlorine.

SIGNIFICANCE

The significance of these efforts relates to the fact that EPA's Office of Drinking Water has adopted the C:t concept to quantify the inactivation of Giardia lamblia by disinfection with free chlorine. Whether or not a utility is forced to install surface water treatment will depend on its ability to meet the C:t values specified by the SWTR. Even if the utility is not required to install filtration a utility may have to make significant investments in holding basins and disinfection capacity in order to meet these requirements. Therefore C:t values established under the SWTR will be extremely important to the drinking water industry and the authors believe it is important that the industry understand the basis for the procedures used to estimate these values. This paper describes the way in which C:t values were calculated for the SWTR. It is unlikely that utilities can directly use the models developed in this paper, although it is important that they understand the mechanism by which C:t values have been derived. Tables generated from the model will be useful as they provide the C:t values for Giardia inactivation by chlorine that utilities must achieve. These tables are presented at the end of the paper.

THEORY

Current disinfection theory is based on the Chick or Chick-Watson model. Chick's law expresses the rate of destruction of microorganisms based on a first-order chemical reaction.⁶

$$dN/dt = -kt \quad (1)$$

which when integrated yields

$$\ln (N_t/N_o) = -kt \quad (2)$$

where

N_t = number of organisms present at time t (minutes)

N_o = number of organisms present at time 0

k = rate constant characteristic of type of disinfectant, microorganism, and water quality aspects of system (minutes⁻¹)

t = time (minutes)

Watson, using Chick's data, refined this equation to produce an empirical relation that included changes in the disinfectant concentration:⁷

$$\ln (N/N_o) = r C^n t \quad (3)$$

where

C = concentration of disinfectant [(milligrams/liter)^{1/n}]

r = coefficient of specific lethality (liters/milligram \cdot minutes)

n = coefficient of dilution (liters/milligrams \cdot minutes)

or

$$(1/r) \ln (N_t/N_o) = C^n t \quad (4)$$

For a given level of survival such as $N_t/N_o = 0.001$ (3 log reduction) the left hand side of equation 4 is a constant K , or

$$K = C^n t \quad (5)$$

The value K will vary depending on the level of inactivation.

EFFECT OF OTHER VARIABLES

As indicated previously C:t values have been found to be a function of pH, temperature, disinfectant concentration and level of inactivation.⁸

Therefore in this study equation 5 was reformulated as follows:

$$C:t = C^{-(n-1)} K \quad (6)$$

where

K = f (pH, temp, I)

I = ratio of organisms at time t to the organisms at time 0 (N_t/N_0)

temp = temperature at which experiment was conducted in °C

pH = pH at which experiment was conducted in pH units

Equation 6 can be rewritten in the form:

$$C:t = R I^a C^b \text{pH}^c \text{temp}^d \quad (7)$$

where

R, a, b, c, and d are coefficient to be determined.

A more convenient form for coefficient estimation and the one used in this paper is as follows:

$$t = R I^a C^{b-1} \text{pH}^c \text{temp}^d \quad (8)$$

As will be discussed in the following sections these coefficients will be determined by a statistical analysis using appropriate data bases.

COEFFICIENT ESTIMATES

Several data sets are available for estimating the coefficients in equation 8. Data sets have been developed by Jarroll, Hibler, Rice and Rubin.^{5,9,10,11}

Much of the available Giardia inactivation data is based on excystation rather than animal infectivity since it is an easier measure of cyst viability.¹¹ Hoff et al. compared mouse infectivity and excystation for

determining the viability of G. muris cysts exposed to chlorine and reported that both methods yielded similar results.¹² Hibler et al. used Mongolian gerbils to determine the effects of chlorine on G. lamblia cysts.⁹ In a series of experiments, cysts were exposed for various time periods to free chlorine concentrations ranging from 0.4 to 4.2 mg/L at 0.5, 2.5, and 5.0°C and pH 6, 7, and 8. Each of 5 gerbils was fed 5×10^4 of the chlorine exposed cysts and subsequently examined for evidence of infection. Since the test animals had each received a dose of 5×10^4 of the chlorine exposed cysts and subsequently examined for evidence of infection and since infectivity studies with unchlorinated cysts showed that approximately 5 cysts usually constituted an infective dose, the following assumptions were made depending on the infectivity patterns occurring in the animals. If all five animals were infected, it was assumed that C:t had produced less than 99.99 percent inactivation and if no animals were infected, that it had produced greater than 99.99 percent inactivation.⁹ If, however, 1-4 animals were infected it was assumed that the level of viable cysts were 5 per animal and that 99.99 percent of the original cyst population had been inactivated. Hibler interpolated from the results and provided comprehensive tables showing C:t values at 0.5°C temperature intervals.⁹ Because of observations indicating that C:t values increased as chlorine concentration increased within the range of chlorine concentrations used, Hibler et al. advised against use of the C:t values for chlorine concentrations above 2.5 mg/L.

Table 2 summarizes Hibler's data for the different experimental conditions examined. Column 3 shows the range of chlorine concentrations in mg/L to which cysts were exposed before being fed to the gerbils, and Column 7 shows the number of experiments which yields 1-4 infected gerbils out of 5.

Column 4 shows the range of cyst exposure times and Column 5 contains the range of C't values that are the product of the chlorine concentration and cyst exposure time.

TABLE 2. C'T VALUES FOR 99.99 PERCENT INACTIVATION BASED ON ANIMAL INFECTIVITY DATA

pH	Temp °C	Range of Conc. (mg/L)	Range of Cyst Exposure Time (min)	Range of C't values from Data	Range of Predicted C't Values	Number of Observations
6	0.5	0.56-3.96	39-300	113-263	136-192	25
6	2.5	0.53-3.80	18-222	65-212	107-151	15
6	5	0.44-3.47	25-287	50-180	93-134	26
7	0.5	0.51-4.05	76-600	156-306	205-295	14
7	2.5	0.64-4.23	55-350	124-347	169-235	14
7	5	0.73-4.08	47-227	144-222	156-211	15
8	0.5	0.49-3.25	132-593	159-526	294-410	22
8	2.5	0.50-3.24	54-431	175-371	233-324	21
8	5	0.84-3.67	95-417	200-386	209-299	15

Hibler's data set, based on animal infectivity, is appealing because it is a more direct indicator of cyst viability than data based on excystation. However the C't values in this data set are based solely on 99.99 percent inactivation. The other three data sets, based on excystation, have values calculated for all four parameters in equation 8. Table 3 contains a summary characterization of the studies on which these data sets were based. Because no one individual experiment provided the exact characteristics required for this study an attempt was made to find the "most consistent" set of data for parameter estimation, which might include several of the data sets discussed.

**TABLE 3. CHARACTERIZATION OF G. LAMBLIA FREE CHLORINE*
INACTIVATION STUDIES USED IN PREDICTIVE MODELS**

Reference No.	Cyst Source	Viability Assay	Comments
5	Symptomatic human	excystation	Conventional survival curves based on multiple samples. End point - 0.1% survival
7	Gerbils, adapted from infected humans. (CDC isolate)	gerbil infectivity (5 animals/sample)	No survival curves. Endpoint sought - 0.01% survival
8	Symptomatic and nonsymptomatic humans	excystation	Conventional survival curves based on multiple samples. End point - 0.1% survival
9	Gerbils adapted from infected humans. (Several isolates used)	excystation	Conventional survival curves based on multiple samples. End

*Data provided by Dr. John Hoff formerly of USEPA

The Hibler data set was included in all combinations considered because it was the largest data set, the data set was based on animal infectivity, and the data reflected higher percent inactivation than required under the SWTR. Since the data based on excystation, with the exception of a few data points, only reflected percent inactivation up to 1 log or less than that required under the SWTR, inclusion of the Hibler data was considered essential for developing a model that could predict disinfection conditions for achieving

99.9 percent inactivation with minimum uncertainty. Filtered systems will need to know disinfection conditions for achieving less than 99.9 percent inactivation. Therefore data from at least one of the excystation studies was considered essential since the C't values in the SWTR may be used for calculating partial inactivation levels (i.e., less than 99.9 percent).

A fundamental question that needed to be addressed was the statistical compatibility of the data sets. Initial regression estimates for each of the data sets were made using equation 8.¹³ High "r²" were obtained for these fits but significant differences were found for the "R" coefficient or slope. This indicated that the basic model was adequate but that there were differences in the coefficients as defined by the individual estimates using equation 8. It was decided to "anchor" all of the data sets to the Hibler data set. The approach used was to construct an indicator random variable to move the regression intercept or slope to compensate for data set differences.¹³ The significance of the indicator random variable would support the hypothesis of different regression surfaces, i.e., incompatibility of the data sets chosen. The indicator random variable was created in such a way as to always differentiate between the Hibler data set and other data sets considered and to move the regression intercept not the slope. The indicator random variable was defined as follows:

$$z = \begin{cases} 0 & \text{if Hibler data} \\ 1 & \text{if other data} \end{cases} \quad (9)$$

Therefore equation 8 was modified as follows:

$$t = R I^a C^{b-1} \text{pH}^c \text{temp}^d 10^{ez} \quad (10)$$

where t, I, C, pH, temp are defined as in equation 8, and R, a, b, c, d, e are constants determined from regression.

Equation 10 can be transformed as follows:

$$\log t \approx \log R + a \log I + (b-1) \log C + c \log pH + d \text{ temp} + ez \quad (11)$$

In equation 11 when $z = 0$ equation 10 is defined over the Hibler data set, and

$$t = R I^a C^{b-1} pH^c \text{ temp}^d \quad (12)$$

When $z = 1$ equation 10 is defined over the remaining data and

$$t = (R \cdot 10^e) I^a C^{b-1} pH^c \text{ temp}^d \quad (13)$$

Table 4 displays the data set combinations and regression diagnostics. Note that z is the indicator random variable.

In Table 4, the first column shows the various data sets considered in the analysis. Column two contains the " r^2 " values based on equation 13 for each of the data combinations. Column three indicates major results of the analysis. For example it was found, for the first data set combination, that the intercept, and temperature variable were not significant. Column 4 shows the test that was used to determine whether or not the equation yields biased results.

As indicated in Column 4 of Table 4 residual plots were used to determine constant variance and normality. Fortunately a strict assumption of normality is not required. As stated in Neter, Wasserman and Whitmore "Small departures from normality do not create any serious problems.¹⁴ Major departures, on the other hand, should be of concern". Further they write, "Unless the departures from normality are serious, particularly with respect to skewness, the actual confidence coefficients and risks of error will be close to the levels for exact normality". In addition because of the large sample size one would expect the central limit theories would apply and symmetry would not be an issue.

It was found that 90% of the data fell within plus/or/minus 1.64 standard deviations of the mean. In addition 75% of the data fell within plus or minus 1 minus standard deviation which gives support for the normality assumption. [For a perfect normal distribution we would expect 68% of the data to lie within plus or minus 1 standard deviation. Similarly, we would expect 90% to lie within plus or minus 1.64 standard deviation of the mean].

The indicator random variable for the intercept variable using the Hibler, Jarroll data base was not significant (p-value = 0.3372). All other data bases considered had a significant indicator random variable at the 0.095 level of significance. A formal test for differences of intercept and/or slope between the Hibler and Jarroll data sets was conducted and no difference was detected.

As mentioned previously the Hibler data set does possess some desirable characteristics and it is the largest data set among all data sets available. However one might argue that by forcing the Hibler data set into the analysis the possibility has been ignored that the other data sets may be mutually consistent, and the Hibler data set may represent an "outlier". In addition, one might hypothesize that data from different experimental situations prohibits us from making a reasonable comparison among these excystation studies. Table 4 shows that the Hibler and Jarroll data sets are compatible. Since Table 4 also shows that Hibler-Rice and Hibler-Rubin is not consistent, then it is reasonable to assume that the Jarroll data is not consistent with the Rice and Rubin data so that the Hibler data is not alone in being inconsistent with the other data sets. It seems reasonable therefore to start with the Hibler data set, the largest one, then incorporate other smaller data sets into the modeling process. Thus logic supports the use of the Hibler,

Jarroll data base for extending the model development and the coefficients in equation 8 were estimated using these data as shown in Table 5 in the log transformed form.¹³

TABLE 4. DIAGNOSTIC RESULTS FROM DATA SET COMBINATION ANALYSIS

Data sets considered	R-Square	Variables	Plots
Hibler, Rice, Jarroll, Rubin	0.6801	intercept, temp not-significant	non-normal data non-constant var
Hibler, Rice, Jarroll, Rubin, z	0.7316	intercept, temp not-significant	non-normal data non-constant var
Hibler, Rice, Rubin	0.6649	intercept, temp not-significant	non-normal data non-constant var
Hibler, Rice, Rubin, z	0.7899	intercept not-significant	non-normal data non-constant var
Hibler,, Jarroll, Rubin	0.6424	intercept, temp not-significant	non-normal data non-constant var
Hibler, Jarroll, Rubin, z	0.6879	intercept, temp not-significant	non-normal data non-constant var
Hibler, Rice, Jarroll	0.8619	all variables significant	non-normal data non-constant var
Hibler, Rice, Jarroll, z	0.865	all variables significant	non-normal data non-constant var
Hibler, Rubin	0.6483	temp not-significant	non-normal data non-constant var
Hibler, Rubin, z	0.7593	intercept not-significant	non-normal data constant var
Hibler, Rice	0.8548	all variables significant	non-normal data constant var
Hibler, Rice, z	0.8678	all variables significant	non-normal data constant var
Hibler, Jarroll	0.8452	all variables significant	non-normal data constant var
Hibler, Jarroll, z	0.8459	z not significant	non-normal data constant var

TABLE 5. COEFFICIENT ESTIMATES FOR EQUATION 8.

Variable	DF	Coefficient	Standard Error	Statistical Analysis		Variance Inflation Factor
				T for H ₀ : Parameter=0	PROB > 0	
INTERCEP	1	-0.902	0.200	-4.518	0.0001	0.000
LOGI	1	-0.268	0.014	-19.420	0.0001	1.183
LOGCHLOR	1	-0.812	0.042	-19.136	0.0001	1.033
LOGPH	1	2.544	0.221	11.535	0.0001	1.032
LOGTEMP	1	-0.146	0.028	-5.117	0.0001	1.179

In Table 5 column 7 entitled the "Variance Inflation Factor (VIF)" is defined as $(1-R_k^2)$ where R_k^2 is the coefficient of multiple determination when X_k is regressed on the other variables in the model. The minimum value of VIF is 1 if there is no multicollinearity. As shown in column 7 all of the variance inflation factors are close to one.

DISCUSSION OF MODEL

As discussed in the previous sections the coefficients for equation 8 were determined by a combination of log transformation and linear regression. An issue to consider is the probability that there is measurement error in the model's independent variables and the effect that this could have on estimates of the parameters.

Regression is intended to fulfill the dual purposes of prediction and explanation. The purpose of equation 8 is primarily to predict by providing water utilities guidance as to what C't values will be needed for a desired level of inactivation. The purpose of this model is to predict C't values and will not be hampered by measurement error as long as consistency is maintained.¹⁵ Since any measurement is subject to some type of error, the approach taken to deal with this issue was to provide safe or "conservative estimates" of C't values.

As one of the diagnostic procedures applied to the analysis equation 13 was evaluated for multicollinearity. As can be see from Table 5 all of the coefficients are highly significant and there is no multicollinearity.

TABLE 6. COLLINEARITY DIAGNOSTICS

Condition Number	VAR PROP Intercep	VAR PROP LOGI	VAR PROP LOGCHLOR	VAR PROP LOGPH	VAR PROP LOGTEMP
1.000	0.0002	0.0031	0.0214	0.0003	0.0174
2.495	0.0001	0.0063	0.0138	0.0001	0.7833
2.801	0.0003	0.0067	0.9285	0.0004	0.0005
10.662	0.0147	0.9266	0.0029	0.0253	0.1918
45.636	0.9847	0.0574	0.0334	0.9739	0.0071

In Table 6 VAR PROP is the variance-decomposition proportion (VDP) and has a maximum value of 1. A high condition number coupled with high VDP values for two or more coefficients is an indication of multicollinearity between those variables. A condition of 45.636 in conjunction with an intercept VDP of 0.9847 and Log(pH) VDP of 0.9739 indicated a dependency between the intercept and Log(pH) variable, however, multicollinearity among the other coefficients were nonexistent.

The final equation used for predicting C:t values in the SWTR was based on equation 8 as follows:

$$C:t = RI^a C^b pH^c temp^d \quad (14)$$

Confidence intervals of the coefficients estimate for equation 14 based on the Bonferroni method at a 99% confidence interval are:^{14,16}

R: (0.384, 0.4096)
a: (-0.2321, -0.3031)
b: (0.0792, 0.2977)
c: (1.9756, 3.1117)
d: (-0.2192, -0.0724)

RESULTS

There are many uncertainties regarding the various data sets that might be considered for calculating C:t values. The random variable analysis shows the statistical incompatibility among most of these data sets. More work needs to be done to define the impact of strain variation and in vivo versus in vitro techniques on C:t values. In order to provide conservative estimates for C:t values in the SWTR and the guidance document the authors used the approach illustrated in Figure 1.

In Figure 1 the 99% confidence interval of the 4 log inactivation level is calculated. First order kinetics are then assumed so that the inactivation "line" goes through 1 at C:t = 0 and a C:t value equal to the upper 99% confidence interval at 4 logs of inactivation. As can be seen the inactivation line consists of higher C:t values than all of the mean predicted C:t values from equation 14, most of the Jarroll et al., and most of the Hibler data points. Conservative C:t values, for a specified level of inactivation, can be obtained from the inactivation line prescribed by the disinfection conditions. For the example indicated in Figure 1, the appropriate C:t for achieving 99.9% inactivation would be 105. This approach (assumption of first order kinetics) also provides the basis for establishing credits for sequential disinfection steps allowed under the SWTR. It should be noted that this approach provides very conservative estimates at mid range levels of C:t.

Note in Figure 1 that some of the individual data points fall outside the 99% confidence interval estimated at the four logs of inactivation. This is to be expected since the confidence intervals constructed were for mean C:t values, but also indicated the high variability of the Hibler data.

Equation 14 was applied using the above strategy, as a safety factor, to determine the C:t values for 99.9 percent inactivation at 0.5°C and 5°C in the

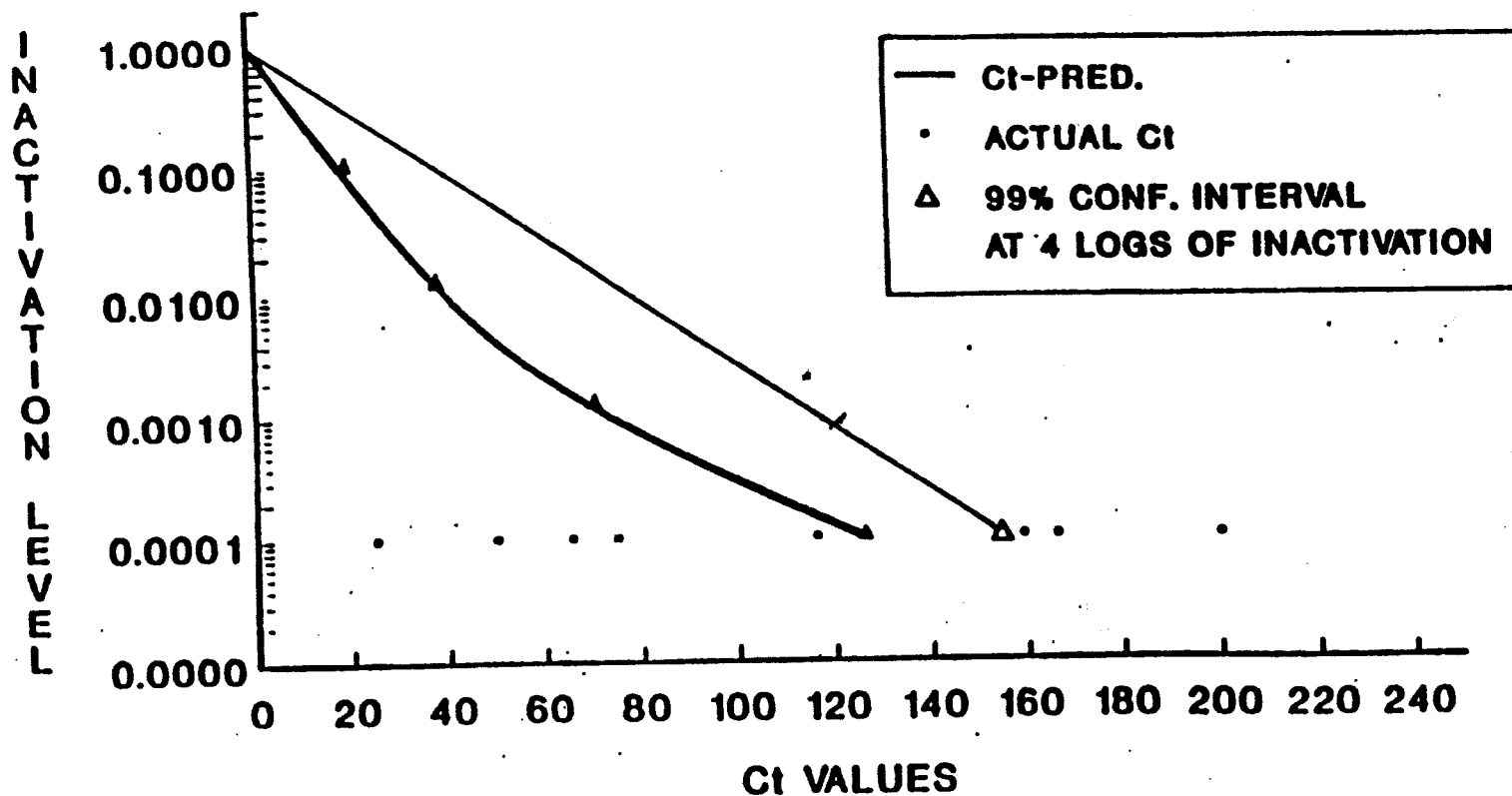

**FIGURE 1. 99% CONFIDENCE LEVELS USING
EQUATION 14 FOR CHLORINE = 2 mg/l;
PH = 6; TEMPERATURE = 5° C**

final SWTR.¹ C·t values for temperatures above 5°C were estimated assuming a twofold decrease for every 10°C increase in temperature since all the Hibler data was generated at 5°C or less. This general principle is supported by Hoff.

Application of equation 14 to pHs above 8, up to 9, was considered reasonable because the model is substantially sensitive to pH (e.g., C·ts at pH 9 are about three times greater than C·ts at pH 6 and about two times greater than C·ts at pH 7). At a pH of 9, approximately four percent of the hypochlorous acid fraction of free chlorine is still present. Other data indicate that in terms of HOCl residuals (versus total free chlorine residuals including HOCl and OCl⁻) the C·t values required for inactivation of Giardia muris and Giardia lamblia cysts decrease with increasing pH from 7 to 9.¹⁰ However, with increasing pH, the fraction of free chlorine existing as the weaker oxidant species (OCl⁻) increases. In terms of total free chlorine residuals (i.e., HOCl and OCl⁻) the C·t values required for inactivation of Giardia muris and Giardia lamblia cysts increase with increasing pH from 7 to 9 but generally less than by a factor of 2 at concentrations of less than 5.0 mg/L.¹⁰ Table 7 compares the C·t values in the proposed SWTR to those given in the SWTR. The C·t values in the proposed SWTR were based only on the Hibler data and included different safety factors.^{2,8}

TABLE 7. COMPARISON BETWEEN MODIFIED APPROACH (MEANS) AND RULE C-TS AT 99.9% INACTIVATION AND 5°C IN THE PROPOSED AND FINAL SWTR.

Concentration mg/L	pH							
	6		7		8		9	
	Proposed	Final	Proposed	Final	Proposed	Final	Proposed	Final
1	105	108	149	165	216	238	329	312
2	116	122	165	186	243	269	371	353

The C't values in the final SWTR are 0-10 percent lower than in the proposed SWTR. Table 8 presents representative C't values determined by application of the above described approach.

TABLE 8. CALCULATED C-T VALUES FOR GIARDIA INACTIVATION USING USING EQUATION 14 AT 0.5°C and 5°

Values for Inactivation of Giardia Cysts by Free Chlorine at 0.5°C

Chlorine Concentration mg/L	pH = 6				pH = 7				pH = 8				pH = 9			
	Log Inactivation				Log Inactivation				Log Inactivation				Log Inactivation			
	0.5	1.0	2.0	3.0	0.5	1.0	2.0	3.0	0.5	1.0	2.0	3.0	0.5	1.0	2.0	3.8
0.4	23	46	91	137	33	65	130	195	46	92	185	277	65	130	260	390
1	25	49	99	148	35	70	140	210	51	101	203	304	73	146	291	437
2	28	55	110	165	39	79	157	236	58	115	231	346	83	167	333	500
3	30	60	121	181	44	87	174	261	64	127	255	382	92	184	368	552

Values for Inactivation of Giardia Cysts by Free Chlorine at 5°C

Chlorine Concentration mg/L	pH = 6				pH = 7				pH = 8				pH = 9			
	Log Inactivation				Log Inactivation				Log Inactivation				Log Inactivation			
	0.5	1.0	2.0	3.0	0.5	1.0	2.0	3.0	0.5	1.0	2.0	3.0	0.5	1.0	2.0	3.8
0.4	16	32	65	97	23	46	93	139	33	66	137	198	47	93	186	279
1	18	35	70	105	25	50	99	149	36	72	144	216	52	104	208	312
2	19	39	77	116	28	55	110	165	41	81	162	243	59	118	235	353
3	21	42	84	126	30	61	121	182	45	89	179	268	65	130	259	389

Because calculations for the SWTR C:t values are the upper limit on the error bounds associated with equation 14 (Table 8), an equation was developed to estimate these C:t values for 0.5 and 5°C directly. C:t values above 5°C can be estimated by using the method given below to estimate C:t values at 5°C, then the assumption that there is a twofold decrease in C:t values for every 10°C increase in temperature can be applied. The equation for the estimated C:t values at 0.5 and 5°C is as follows:

$$C:t = 0.36 \text{ pH}^{2.69} \text{ temp}^{-0.15} C^{0.15} (-\log I)^{1.00} \quad (R^2 = 0.998) \quad (15)$$

where the variables in equation 15 are as defined previously.

Table 9 compares the values estimated by equation 15 and the SWTR values shown in Table 8.

TABLE 9. CALCULATED C:T VALUES FOR GIARDIA INACTIVATION USING EQUATION 15 AT 0.5 AND 5°C

Values for Inactivation of Giardia Cysts by Free Chlorine at 0.5°C																
Chlorine Concentration mg/L	pH = 6				pH = 7				pH = 8				pH = 9			
	Log Inactivation				Log Inactivation				Log Inactivation				Log Inactivation			
	0.5	1.0	2.0	3.0	0.5	1.0	2.0	3.0	0.5	1.0	2.0	3.0	0.5	1.0	2.0	3.8
0.4	22	43	86	129	33	65	131	196	47	94	187	281	64	129	257	385
1	25	49	99	148	37	75	149	224	54	107	214	321	74	147	294	441
2	27	55	109	164	41	83	165	248	59	118	137	355	81	163	325	487
3	29	58	116	174	44	88	175	263	63	126	251	377	86	173	345	517

Values for Inactivation of Giardia Cysts by Free Chlorine at 5°C																
Chlorine Concentration mg/L	pH = 6				pH = 7				pH = 8				pH = 9			
	Log Inactivation				Log Inactivation				Log Inactivation				Log Inactivation			
	0.5	1.0	2.0	3.0	0.5	1.0	2.0	3.0	0.5	1.0	2.0	3.0	0.5	1.0	2.0	3.8
0.4	15	31	61	91	23	46	92	138	33	66	132	198	46	91	182	272
1	17	35	70	104	26	53	106	158	38	76	151	227	52	104	208	311
2	19	39	77	116	29	58	117	175	42	84	167	251	58	115	320	345
3	20	41	82	123	31	62	124	186	44	89	178	266	61	122	244	366

FUTURE WORK

Because of the importance from an economic and a public health viewpoint of the calculation of C't values for the inactivation of Giardia lamblia by free chlorine, much effort has been expended in developing models that interrelate the important variables effecting these values.⁸ The work reported in this paper reflects the authors attempts to develop such a relationship for inclusion in the SWTR. However, it also raises a very interesting point regarding the application of statistical methodology to public policy decision problems. There is no perfect "regulatory" experiment that answers all of the textbook questions that could be raised regarding regulatory decision making. One has to use available data and incorporate the best judgment that can be brought to bear on a given issue to insure that public health and welfare is protected. The need to combine data sets from different investigations and then develop a decision rule based on the data, as shown in this paper, as an example of the this process.

There is no doubt in the authors' mind that other better models may be developed. For example, Haas' work in applying the Hom model to inactivation data and incorporating the method of Maximum Likelihood for estimating parameters is promising.¹⁷ The authors believe that the public is best served by examining problems from many different points of view and encourage others to pursue these difficult, frustrating but extremely challenging problems.

SUMMARY AND CONCLUSIONS

Amendments to the Safe Drinking Water Act clearly require that all surface water suppliers in the U.S. filter and/or disinfect to protect the health of their customers. G. lamblia has been identified as one of the leading causes of waterborne disease outbreaks in the U.S. G. lamblia cysts are also one of the most resistant organisms to disinfection by free chlorine.

EPA's Office of Drinking Water has adopted the C:t concept to quantify the inactivation of G. lamblia cysts by disinfection. If a utility can assure that a large enough C:t can be maintained to ensure adequate disinfection then, depending upon site specific factors, it may not be required to install filtration. Similarly, the C:t concept can be applied to filtered systems for determining appropriate levels of protection.

In this paper, an equation has been developed that can be used to predict C:t values for the inactivation of G. lamblia by free chlorine based on the interaction of disinfectant concentration, temperature, pH, and inactivation level. The parameters for this equation have been derived from a set of animal infectivity and excystation data. The equation can be used to predict C:t values for achieving 0.5 to 4 logs of inactivation, within temperature ranges of 0.5 to 5°C, chlorine concentration ranges up to 4 mg/L, and pH levels of 6 to 8. While the model was not based on pH values above 8, the model is still considered applicable up to pH level of 9. The equation shows the effect of disproportionate increases of C:t versus inactivation levels. Using 99% confidence intervals at the 4 log inactivation levels and applying first order kinetics to these end points a conservative regulatory strategy for defining C:t at various levels of inactivation has been developed. This approach represents an alternative to the regulatory strategy previously proposed.

ACKNOWLEDGMENTS

The authors would like to acknowledge Ms. Patricia Pierson and Ms. Diane Routledge for their assistance in preparing this manuscript. The authors are grateful to Dr. John Hoff, formerly of USEPA, Ms. Shirley Pien and Ms. Eleanor Read of the Computer Sciences Corporation, Mr. Dennis Black of the University of Nevada, Las Vegas, and Dr. Charles Haas of the Illinois Institute of Technology for their review and suggestions to improve the manuscript. The authors would like to extend a special acknowledgement to Ms. Dianne Wild for her assistance in the preparation of this manuscript.

REFERENCES

1. National Primary Drinking Water Regulations: Filtration, Disinfection, Turbidity, Giardia lamblia, Viruses, Legionella, and Heterotrophic Bacteria. Final Rule, 40 CFR parts 141 and 142. Fed. Reg. 54:124:27486 (June 29, 1989).
2. U.S. Environmental Protection Agency, Office of Drinking Water, Criteria and Standards Division. Guidance Manual for Compliance with the Filtration and Disinfection Requirements for Public Water Systems Using Surface Water Sources, October 1987.
3. Clarke, N. A., Berg, C., Kabler, P. W., and Chang, S. L., "Human Enteric Viruses in Water: Source, Survival, and Removability". International Conference on Water Pollutions Research, Landar, September, 1962.
4. Hoff, J. C., Rice, E. W., and Schaefer III, F. W. "Disinfection and the Control of Waterborne Giardiasis", In Proceedings of the 1984 Specialty Conference, Environmental Engineering Division, ASCE, June 1984.
5. Jarroll, E. L., Bingham, A. K., and Meyer, E. A. "Effect of Chlorine on Giardia Lamblia Cyst Viability". Applied and Environmental Microbiology, Vol. 41, pp. 483-48, February, 1981.
6. Chick, H., "an Investigation of the Laws of Disinfection:", J. Hygiene, 8, 92 (1908).
7. Watson, W. E., "A Note on the Variation of the Rate of Disinfection with Change in the Concentration of the Disinfectant", J. Hygiene, 8, 536 (1908).
8. Clark, R. M., Read, E. J., and Hoff, J. C. "Analysis of Inactivation of Giardia Lamblia by Chlorine", Journal of Environmental Engineering, ASCE, Vol. 115, No. 1, February, 1989, pp. 80-90.
9. Hibler, C. P., Hancock, C. M., Perger, L. M., Wegrzyn, J. G. and Swabby, K. D. "Inactivation of Giardia Cysts with Chlorine at 0.5°C to 5.0°C. american Water Works Association Research Foundation, 6666 West Quincy Avenue, Denver, Colorado 80235, 1987.
10. Rice, E. W., Hoff, J. C. and Schaefer III, F. W. "Inactivation of Giardia Cysts by Chlorine", Applied and Environmental Microbiology, Jan. 1982, Vol. 43, No. 1, pp. 250-251.
11. Rubin, A. J., Evers, D. P., Eyman, C. M., and Jarroll, E. L., "Inactivation of Gerbil-Cultured Giardia Lamblia Cysts by Free Chlorine", Applied and Environmental Microbiology, Oct. 1989, Vol. 55, No. 10, p. 2592-2594.
12. Hoff, J. C., "Inactivation of Microbial Agents by Chemical Disinfectants" EPA/600/2-86-067.
13. Draper, N. and Smith, H. (1981) Second Edition, Applied Regression Analysis, Wiley: New York.

14. Neter, J. and Wasserman, W. (1974), Applied Linear Statistical Models, Irwin: Homewood, IL.
15. Fuller, Wayne, Measurement Error Models, John Wiley & Sons, 1987.
16. Belsley, D. A., Kuh, e. and Welsch, R. E. (1980), Regression Diagnostics, Wiley: New York.
17. Haas, Charles W., and Hillar, B. Statistical Analysis of Data on Chlorine Inactivation of Giardia Lamblia, Final Report prepared for U.S. EPA Office of Drinking Water, January 6, 1988.

GLOSSARY

- $d N_t/dt$ = rate of change of organisms with respect to time
- k = inactivation rate in minutes⁻¹
- t = time in minutes
- N_t = number of organisms at time t
- N_0 = number of organisms at time 0
- r = coefficient of specific lethality (liters/milligram - minutes)
- C = concentration of disinfectant [milligrams/liter]^{1/n}
- n = coefficient of dilution
- K = constant at given level temperature, pH and inactivation level
- pH = pH in water phase
- temp = temperature in °C
- I = level of inactivation
- $C \cdot t$ = concentration in mg/L times time in minutes
- R = coefficient to be determined
- a = coefficient to be determined
- c = coefficient to be determined
- d = coefficient to be determined
- e = coefficient to be determined
- z = coefficient to be determined
- VIF = variance inflation factor. If VIF is 1 there is no multicollinearity
- VDP = variance decomposition number. If VDP is high for two or more variables there is an induction of multicollinearity between variables
- Bonferroni technique = a conservative method of estimating confidence intervals

permanganate as a disinfectant. It is not meant to be used as a basis for establishing CT requirements.

References

Berman, D.; Hoff, J. Inactivation of Simian Rotavirus SA 11 by Chlorine, Chlorine Dioxide and Monochloramine. *Appl. Environ. Microbiol.*, 48:317-323, 1984.

Chang, J.C.H.; Ossoff, S.F.; Lobe, D.C.; Dorfman, M.H.; Dumais, C.M.; Qualls, R.G.; Johnson, J.D. Inactivation of Pathogenic and Indicator Microorganisms. *Applied Environ. Micro.*, June 1985, pp. 1361-1365.

Clark, R.M.; Read, E.J.; Hoff, J.C. Inactivation of Giardia lamblia by Chlorine: A Mathematical and Statistical Analysis. Unpublished Report, EPA/600/x-87/149, DWRD, Cincinnati, OH, 1987.

Clark, R.; Regli, S.; Black, D. Inactivation of Giardia lamblia by Free Chlorine: A Mathematical Model. Presented at AWWA Water Quality Technology Conference. St. Louis, Mo., November 1988.

Clark, M.R.; Regli, S. The Basis for Giardia CT Values in the Surface Water Treatment Rule: Inactivation by Chlorine. Submitted to *Journal of Water Supply Research and Technology-Aqua*, August 1990.

Hibler, C.P.; C.M. Hancock; L.M. Perger; J.G. Wegrzn; K.D. Swabby Inactivation of Giardia cysts with Chlorine at 0.5 C to 5.0 C American Water Works Association Research Foundation, In press, 1987.

Hoff, J.C. Inactivation of Microbial Agents by Chemical Disinfectants, EPA/600/52-86/067, U.S. Environmental Protection Agency, Water Engineering Research Laboratory, Cincinnati, Ohio, September, 1986.

Jarroll, E.L.; A.K. Binham; E.A. Meyer Effect of Chlorine on Giardia lamblia Cyst Viability. *Appl. Environ. Microbiol.*, 41:483-487, 1981.

Leahy, J.G.; Rubin, A.J.; Sproul, O.J. Inactivation of Giardia muris Cysts by Free Chlorine. *Appl. Environ. Microbiol.*, July 1987.

Rice, E.; Hoff, J.; Schaefer, F. Inactivation of Giardia Cysts by Chlorine. *Appl. and Environ. Microbiology*, 43:250-251, January 1982.

Roy, D., R.S. Engelbrecht, and E.S.K. Chian. Comparative Inactivation of Six Enteroviruses by Ozone. *J. AWWA*, 74(12):660, 1982.

Rubin, A. Factors Affecting the Inactivation of Giardia Cysts by Monochloramine and Comparison with other Disinfectants. Water Engineering Research Laboratory, Cincinnati, OH March 1988a.

Rubin, A. "CT Products for the Inactivation of Giardia Cysts by Chlorine, Chloramine, Iodine, Ozone and Chlorine Dioxide" submitted for publication in J. AWWA, December, 1988b.

Sobsey, M. Detection and Chlorine Disinfection of Hepatitis A in Water. CR-813-024. EPA Quarterly Report. December 1988.

Vaughn, J.; Chen, Y.; Lindburg, K.; Morales, D. Inactivation of Human and Simian Rotaviruses by Ozone. Appl. Environ. Microbiol., 53(9):2218-2221, September 1987.

Wickramanayake, G.; Rubin, A.; Sproul, O. Effects of Ozone and Storage Temperature on Giardia Cysts. J.AWWA, 77(8):74-77, 1985.

Yahya, M.T., Landeen, L.K., Forsthoefel, N.R., Kujawa, K., and Gerba, C.P. Evaluation of Potassium Permanganate for Inactivation of Bacteriophage MS-2 in Water Systems. Copyright 1988, Carus Chemical Company, Ottawa, Illinois.

APPENDIX G-1

DETERMINING CHLORAMINE INACTIVATION OF GIARDIA
FOR THE SURFACE WATER TREATMENT RULE

Microbiological Treatment Branch
Risk Reduction Engineering Laboratory

and

Parasitology and Immunology Branch
Environmental Monitoring Systems Laboratory
U.S. Environmental Protection Agency
26 West Martin Luther King Drive
Cincinnati, Ohio 45268

TABLE OF CONTENTS

I. Materials.....	3
II. Reagents.....	4
III. <u>Giardia muris</u> Assay.....	7
IV. Disinfection Procedures for <u>Giardia</u>	10
V. Procedure for Determining Inactivation.....	12
VI. Bibliography.....	13
VII. Technical Contacts.....	14
Appendix	
A. Use of the Hemocytometer.....	15
B. Preparation and Loading of Chamber Slides.....	20

The Surface Water Treatment Rule requires 99.9% or greater removal/inactivation of Giardia. The following protocol may be used to determine the percentage of Giardia inactivation obtained by a treatment plant using chloramine disinfection.

I. MATERIALS

A. Materials for Disinfection

1. Stock chlorine solution
2. Stock ammonia solution
3. Stirring device
4. Incubator or water bath for temperatures below ambient
5. Water from treatment plant
6. Giardia muris cysts
7. Assorted glassware
8. Assorted pipettes
9. Reagents and instruments for determining disinfectant residual
10. Sterile sodium thiosulfate solution
11. Vacuum filter device, for 47mm diameter filters
12. 1.0 μ m pore size polycarbonate filters, 47 mm diameter
13. Vacuum source
14. Crushed ice and ice bucket
15. Timer

3. Materials for Excystation

1. Exposed and control Giardia muris cysts
2. Reducing solution
3. 0.1 M sodium bicarbonate
4. Trypsin-Tryode's solution
5. 15 ml conical screw cap centrifuge tubes
6. Water bath, 37°C
7. Warm air incubator or slide warming tray, 37°C
8. Aspirator flask
9. Vacuum source
10. Assorted pipettes
11. Vortex mixer
12. Centrifuge with swinging bucket rotor
13. Chamber slides
14. Phase contrast microscope
15. Differential cell counter
16. Timer

II. REAGENTS

A. Reducing Solution

<u>Ingredient</u>	<u>Amount</u>
glutathione (reduced form)	0.2 g
L-cysteine-HCl	0.2 g
1X Hanks' balanced salt solution	20.0 ml

Dissolve the dry ingredients in the 1X Hanks' balanced salt solution and warm to 37°C before use in the experiment. Prepare fresh, within 1 hour of use.

B. Sodium Bicarbonate Solution, 0.1 M

<u>Ingredient</u>	<u>Amount</u>
Sodium bicarbonate	0.42 g

Dissolve the salt in 10 to 15 ml distilled water. Adjust the volume to 50 ml with additional distilled water and warm to 37°C before use in the experiment. Prepare fresh, within 1 hour of use.

C. Sodium Bicarbonate Solution, 7.5%

<u>Ingredient</u>	<u>Amount</u>
Sodium bicarbonate	7.5 g

Dissolve the sodium bicarbonate in 50 ml distilled water. Adjust the volume to 100 ml with additional distilled water. Store at room temperature.

D. Sodium Thiosulfate Solution, 10%

<u>Ingredient</u>	<u>Amount</u>
Sodium thiosulfate	10.0 g

Dissolve the sodium thiosulfate in 50 ml distilled water. Adjust the volume to 100 ml with additional distilled water. Filter sterilize the solution through a 0.22 μ m porosity membrane or autoclave for 15 minutes at 121°C. Store at room temperature.

E. Tyrode's Solution, 20X

Ingredient	Amount
NaCl	160.0 g
KCl	4.0 g
CaCl ₂	4.0 g
MgCl ₂ · 6H ₂ O	2.0 g
NaH ₂ PO ₄ · H ₂ O	1.0 g
Glucose	20.0 g

Dissolve the dry ingredients in the order listed in 750 ml distilled water. Adjust the volume to 1.0 liter with additional distilled water. If long term storage (up to 1 year) is desired, filter sterilize the solution through a 0.22 μ m porosity membrane.

F. Tyrode's Solution, 1X

Ingredient	Amount
20X Tyrode's solution	5.0 ml

Dilute 5 ml of the 20X Tyrode's solution to a final volume of 100 ml with distilled water.

G. Trypsin-Tyrode's Solution

Ingredient	Amount
Trypsin, 1:100, U.S. Biochemical Co.	0.50 g
NaHCO ₃	0.15 g
1X Tyrode's solution	100.00 ml

With continuous mixing on a stirplate, gradually add 100 ml 1X Tyrode's solution to the dry ingredients. Continue stirring until the dry ingredients are completely dissolved. Adjust the pH of the solution to 8.0 with 7.5% NaHCO₃. Chill the trypsin Tyrode's solution to 4°C. NOTE: Trypsin lots must be tested for their excystation efficiency. Prepare fresh, within 1 hour of use.

H. Polyoxyethylene Sorbitan Monolaurate (Tween 20) Solution, 0.01% (v/v)

Ingredient	Amount
Tween 20	0.1 ml

Add the Tween 20 to 1.0 liter of distilled water. Mix well.

I. Vaspar

<u>Ingredient</u>	<u>Amount</u>
Paraffin	1 part
Petroleum jelly	1 part

Heat the two ingredients in a boiling water bath until melting and mixing is complete.

III. GIARDIA MURIS ASSAY

A. Cysts

Giardia muris cysts may be available from commercial sources. The cysts may be produced in Mongolian gerbils (Meriones unguiculatus) or in mice. Mus musculus, the laboratory mouse, CF-1, BALBc, and C3H/He strains have been used to produce G. muris cysts. The method is labor intensive and requires a good animal facility.

In order for the disinfection procedure to work properly, the G. muris cysts used must be of high quality. Evaluation of a cyst suspension is a subjective procedure involving aspects of morphology and microbial contamination as well as excystation. A good quality G. muris cyst preparation should exhibit the following:

1. Examine cyst stock suspension microscopically for the presence of empty cyst walls (ECW). Cyst suspensions containing equal to or greater than 1% ECW should not be used for determining inactivation at any required level. However, if a 99.9% level of disinfection inactivation is required, the stock cyst suspension must contain <0.1% ECW.
2. Excystation should be 90% or greater.
3. The cyst suspension should contain little or no detectable microbial contamination.
4. Good G. muris cysts are phase bright with a defined cyst wall, peritrophic space, and agranular cytoplasm. Cysts which are phase dark, have no detectable peritrophic space, and have a granular cytoplasm may be non-viable. There generally should be no more than 4 to 5% phase dark cysts in the cyst preparation.

Good G. muris cyst preparations result when the following guidelines are followed during cyst purification from feces:

- a. Use feces collected over a period of 24 hours or less.
- b. The isolation of the cysts from the feces should be done immediately after the fecal material is collected.
- c. Initially, G. muris cysts should be purified from the fecal material by flotation using 1.0 M sucrose.
- d. If the G. muris cyst suspension contains an undesirable density of contaminants after the first sucrose float, further purification is necessary. Two methods for further purification are suggested.
 - 1) Cysts may be reconcentrated over a layer of 0.85 M sucrose in a 50 ml conical centrifuge tube. If this

second exposure to sucrose is not done quickly, high cyst losses can occur due to their increased bouyant density in the hyperosmotic sucrose medium. The cysts must be thoroughly washed free of the sucrose immediately after collection of the interface.

- 2) Cysts can be separated from dissimilar sized contaminants by sedimentation at unit gravity, which will not adversely affect cyst bouyant density, morphology, or viability.

B. Maintenance of Cysts

1. Preparation of stock suspension

Determine the suspension density of the G. muris cyst preparation using a hemocytometer (see Appendix A). Adjust the cyst suspension density with distilled water to approximately $3-5 \times 10^6$ cysts/ml.

2. Storage

Store cysts in distilled water in a refrigerator at 4°C. Cysts should not be used for disinfection experiments if they are more than 2 weeks old (from time of feces deposition).

C. Excystation Assay

A number of G. muris excystation procedures have been described in the scientific literature (see Bibliography, Section VI). Any of these procedures may be used provided 90% or greater excystation of control, uninfected G. muris cysts is obtained. The following protocol is used to evaluate the suitability of cysts in the stock suspension, and to determine excystation in control and disinfected cysts.

1. For evaluating a cyst suspension or for running an unexposed control, transfer 5×10^5 G. muris cysts from the stock preparation to a 15 ml conical screw cap centrifuge tube. An unexposed control should be processed at the same time as the disinfected exposed cysts.
2. Reduce the volume of G. muris cyst suspension in each 15 ml centrifuge tube to 0.5 ml or less by centrifugation at $400 \times g$ for 2 minutes. Aspirate and discard the supernatant to no less than 0.2 ml above the pellet.
3. Add 5 ml reducing solution, prewarmed to 37°C, to each tube.
4. Add 5 ml 0.1 M NaHCO_3 , prewarmed to 37°C, to each tube. NOTE: Tightly close the caps to prevent the loss of CO_2 . If the CO_2 escapes, excystation will not occur.
5. Mix the contents of each tube by vortexing and place in a 37°C water bath for 30 minutes.

6. Remove the tubes from the water bath and centrifuge each for 2 minutes at 400 x g.
7. Aspirate and discard the supernatant to no less than 0.2 ml above the pellet and resuspend the pellet in each tube in 10 ml trypsin-Tyrode's solution chilled to 4°C.
8. Centrifuge the tubes for 2 minutes at 400 x g.
9. Aspirate and discard the supernatant to no less than 0.2 ml above the pellet.
10. Add 0.3 ml trypsin-Tyrode's solution, prewarmed to 37°C, to each tube. Resuspend the G. muris cysts by low speed vortexing.
11. Prepare a chamber slide for each tube (see Appendix B).
12. Seal the coverslip on each chamber slide with melted vaspar and incubate at 37°C for 30 minutes in an incubator or on a slide warmer.
13. After incubation, place a chamber slide on the stage of an upright phase contrast microscope. Focus on the slide with a low power objective. Use a total magnification of 400X or more for the actual quantitation. NOTE: Be careful to keep the objectives out of the vaspar.
14. While scanning the slide and using a differential cell counter, enumerate the number of empty cyst walls (ECW), partially excysted trophozoites (PET), and intact cysts (IC) observed (see Section V for a further description of these forms and the method for calculating percentage excystation). If the percentage excystation in the stock suspension is not 90% or greater, do not continue with the disinfection experiment.

IV. DISINFECTION PROCEDURES FOR GIARDIA

- A. The treatment plant water to be used should be the water influent into the chloramine disinfection unit process used in the plant. If chloramine disinfection is performed at more than one point in the treatment process, e.g., prefiltration and postfiltration, the procedure should simulate as closely as possible actual treatment practice.
- B. Prepare stock ammonia and chlorine solutions to be added to the treatment plant water to achieve the same stoichiometric relationship between chlorine and ammonia that is used in the water treatment plant. These solutions should be concentrated enough so that no more than 2 ml of each solution will be added to the treatment plant water being disinfected.
- C. Determine the contact time by the methods described in the Surface Water Treatment Rule and/or the associated Guidance Manual.
- D. Rinse a 600 ml beaker with treatment plant water to remove any extraneous material that may cause disinfectant demand. Then add 400 ml treatment plant water to the beaker.
- E. Mix the contents of the beaker short of producing a vortex in the center and continue until the conclusion of the experiment.
- F. Equilibrate the 600 ml beaker and its contents as well as the disinfectant reagents to the desired experimental temperature.
- G. Adjust the stock G. muris cyst suspension with distilled water so that the concentration is $2-5 \times 10^6$ cysts/ml.
- H. Add 0.5 ml of the adjusted cyst suspension to the contents of the 600 ml beaker.
- I. Add the disinfectant reagents to the beaker using the same reagents, the same sequence of addition of reagents, and the same time interval between addition of reagents that is used in the disinfection procedure in the treatment plant.
- J. Just prior to the end of the exposure time, remove a sample adequate for determination of the disinfectant residual concentration. Use methods prescribed in the Surface Water Treatment Rule for the determination of combined chlorine. This residual should be the same ($\pm 20\%$) as residual present in the treatment plant operation.
- K. At the end of the exposure time, add 1.0 ml 10% sodium thiosulfate solution to the contents of the 600 ml beaker.
- L. Concentrate the G. muris cysts in the beaker by filtering the entire contents through a 1.0 μ m porosity 47 mm diameter polycarbonate filter.

- M. Place the filter, cyst side up, on the side of a 150 ml beaker. Add 10 ml 0.01% Tween 20 solution to the beaker. Using a Pasteur pipette, wash the G. muris cysts from the surface of the filter by aspirating and expelling the 0.01% Tween 20 solution over the surface of the filter.
- N. Transfer the contents of the 150 ml beaker to an appropriately labeled 15 ml screw cap conical centrifuge tube.
- O. Keep the tube on crushed ice until the excystation assay is performed (see Section III, C) on the disinfectant exposed cysts and on an unexposed control preparation obtained from the stock cyst suspension.

V. PROCEDURE FOR DETERMINING INACTIVATION

A. Giardia muris Excystation Quantitation Procedure

The percentage excystation is calculated using the following formula:

$$\% \text{ excystation} = \frac{\text{ECW} + \text{PET}}{\text{ECW} + \text{PET} + \text{IC}} \times 100,$$

where ECW is the number of empty cyst walls,
 PET is the number of partially excysted trophozoites, and
 IC is the number of intact cysts.

An ECW is defined as a cyst wall which is open at one end and is completely devoid of a trophozoite. A PET is a cyst which has started the excystation process and progressed to the point where the trophozoite has either started to emerge or has completely emerged and is still attached to the cyst wall. An IC is a trophozoite which is completely surrounded with a cyst wall showing no evidence of emergence. For the control, generally 100 forms are counted to determine the percent excystation.

The number of cysts that must be observed and classified (ECW, PET, IC) in the disinfected sample is dependent on the level of inactivation desired and on the excystation percentage obtained in the control.

For 0.5, 1 and 2 \log_{10} reductions, (68%, 90% and 99% inactivation, respectively), the minimum number of cysts to be observed and classified is determined by dividing 100 by the percentage excystation (expressed as a decimal) obtained in the control.

For a 3 \log_{10} reduction (99.9% inactivation) the minimum number of cysts to be observed and classified is determined by dividing 1,000 by the percentage excystation (expressed as a decimal) obtained in the control.

B. Determining Inactivation

The amount of inactivation is determined by comparing the percentage excystation of the exposed cyst preparation to the percentage excystation in the control preparation using the following formula:

$$\% \text{ inactivation} = 100\% - [(\text{exposed } \% \text{ excysted} / \text{control } \% \text{ excysted}) \times 100]$$

If the percentage excystation in the exposed preparation is zero, i.e., only IC (no ECW or PET) are observed and counted, use <1 as the value for "exposed % excysted" in the formula for calculating % inactivation.

VI. BIBLIOGRAPHY

American Public Health Association; American Water Works Association; Water Pollution Control Federation. Standard Methods for the Examination of Water and Wastewater, 16th ed. (1985).

Belosevic, M. & G.M. Faubert. Giardia muris: correlation between oral dosage, course of infection, and trophozoite distribution in the mouse small intestine. *Exp. Parasitol.*, 56:93 (1983).

Erlandsen, L.S. and E.A. Meyer. Giardia and Giardiasis. Plenum Press, New York, (1984).

Faubert, G.M. et al. Comparative studies on the pattern of infection with Giardia spp. in Mongolian gerbils. *J. Parasitol.*, 69:802 (1983).

Feely, D.E. A simplified method for in vitro excystation of Giardia muris. *J. Parasitol.*, 72:474-475 (1986).

Feely, D.E. Induction of excystation of Giardia muris by CO₂. 62nd Annual Meeting of the American Society of Parasitologists, Lincoln, Nebraska, Abstract No. 91 (1987).

Gonzalez-Castro, J., Bermejo-Vicedo, M.T. and Palacios-Gonzalez, F. Desenquistamiento y cultivo de Giardia muris. *Rev. Iber. Parasitol.*, 46:21-25 (1986).

Melvin, D.M. and H.M. Brooke. Laboratory Procedures for the Diagnosis of Intestinal Parasites. 3rd ed., HHS Publication No. (CDC) 82-8282 (1982).

Miale, J.B. Laboratory Medicine Hematology, 3rd ed. C. V. Mosby Company, St. Louis, Missouri (1967).

Roberts-Thomson, I.C. et al. Giardiasis in the mouse: an animal model. *Gastroenterol.*, 71:57 (1976).

Sauch, J.F. Purification of Giardia muris cysts by velocity sedimentation. *Appl. Environ. Microbiol.*, 48:454 (1984).

Sauch, J.F. A new method for excystation of Giardia. Advances in Giardia Research. University of Calgary, Calgary, Canada (In Press).

Schaefer, III, F.W., Rice, E.W., & Hoff, J.C. Factors promoting In vitro excystation of Giardia muris cysts. *Trans. Roy. Soc. Trop. Med. Hyg.*, 78:795 (1984).

VII. TECHNICAL CONTACTS:

- A. Eugene W. Rice
Microbiological Treatment Branch
Risk Reduction Engineering Laboratory
U.S. Environmental Protection Agency
26 West Martin Luther King Drive
Cincinnati, Ohio 45268
- Phone: (513) 569-7233
- B. Frank W. Schaefer, III
Parasitology and Immunology Branch
Environmental Monitoring Systems Laboratory
U.S. Environmental Protection Agency
26 West Martin Luther King Drive
Cincinnati, Ohio 45268
- Phone: (513) 569-7222

Appendix A: Use of the Hemocytometer

Suspension Density Determination Using the Improved Neubauer (Bright-line) Hemocytometer

The hemocytometer consists of two chambers separated by a transverse trench and bordered bilaterally by longitudinal trenches. Each chamber is ruled and consists of nine squares, each 1 x 1 x 0.1 mm with a volume of 0.1 mm³. Each square mm is bordered by a triple line. The center line of the three is the boundary line of the square. (See Figure 1).

According to the U. S. Bureau of Standards' requirements, the cover glass must be free of visible defects and must be optically plane on both sides within plus or minus 0.002 mm. ONLY HEMOCYTOTOMETER COVER GLASSES MAY BE USED. ORDINARY COVER GLASSES AND SCRATCHED HEMOCYTOTOMETERS ARE UNACCEPTABLE, as they introduce errors into the volume relationships.

The suspension to be counted must be evenly distributed and free of large debris, so that the chamber floods properly. The suspension to be counted should contain 0.01% Tween 20 solution to prevent Giardia cysts from sticking and causing improper hemocytometer chamber flooding. Cyst suspensions should be adjusted so that there are a total of 60 to 100 cysts in the four corner counting squares. Counts are statistically accurate in this range. If the suspension is too numerous to be counted, then it must be diluted sufficiently to bring it into this range. In some cases, the suspension will be too dilute after concentration to give a statistically reliable count in the 60-100 cyst range. There is nothing that can be done about this situation other than to record the result as questionable.

To use the hemocytometer:

1. Dilute or concentrate the suspension as required.
2. Apply a clean cover glass to the hemocytometer and load the hemocytometer chamber with 8-10 μ l of vortexed suspension per chamber. If this operation has been properly executed, the liquid should amply fill the entire chamber without bubbles or overflowing into the surrounding moats. Repeat this step with a clean, dry hemocytometer and cover glass, if loading has been incorrectly done. See step (12) below for the hemocytometer cleaning procedure.
3. Do not attempt to adjust the cover glass, apply clips, or in any way disturb the chamber after it has been filled. Allow the Giardia cysts to settle 30 to 60 seconds before starting the count.
4. The Giardia cysts may be counted using a magnification 200-600X.
5. Move the chamber so the ruled area is centered underneath it.
6. Then, locate the objective close to the cover glass while watching it from the side of rather than through the microscope.

7. Focus up from the coverslip until the hemocytometer ruling appears.
8. At each of the four corners of the chamber is a 1 mm² divided into 16 squares in which Giardia cysts are to be counted (see Figure 1). Beginning with the top row of four squares, count with a hand tally counter in the directions indicated in Figure 2. Avoid counting Giardia cysts twice by counting only those touching the top and left boundary lines and none of those touching the lower and right boundary lines. Count each square mm in this fashion.
9. The formula for determining the number of Giardia cysts per ml suspension is:

$$\frac{\# \text{ of cysts counted}}{\# \text{ of sq. mm counted}} \times \frac{10}{1 \text{ mm}} \times \frac{\text{dilution factor}}{1} \times \frac{1,000 \text{ mm}^3}{1 \text{ ml}} =$$

cysts/ml

10. Record the result on a data sheet similar to that shown in Figure 3.
11. A total of six different hemocytometer chambers must be loaded, counted, and then averaged for each Giardia cyst suspension to achieve optimal counting accuracy.
12. After each use, the hemocytometer and coverslip must be cleaned immediately to prevent the cysts and debris from drying on it. Since this apparatus is precisely machined, abrasives cannot be used to clean it as they will disturb the flooding and volume relationships.
 - a. Rinse the hemocytometer and cover glass first with tap water, then 70% ethanol, and finally with acetone.
 - b. Dry and polish the hemocytometer chamber and cover glass with lens paper. Store it in a secure place.
13. A number of factors are known to introduce errors into hemocytometer counts. These include:
 - a. Inadequate suspension mixing before flooding the chamber.
 - b. Irregular filling of the chamber, trapped air bubbles, dust, or oil on the chamber or coverslip.
 - c. Chamber coverslip not flat.
 - d. Inaccurately ruled chamber.
 - e. The enumeration procedure. Too many or too few Giardia cysts per square, skipping or recounting some Giardia cysts.

- f. Total number of Giardia cysts counted is too low to give statistical confidence in result.
- g. Error in recording tally.
- h. Calculation error; failure to consider dilution factor, or area counted.
- i. Inadequate cleaning and removal of cysts from the previous count.
- j. Allowing filled chamber to sit too long so that chamber suspension dries and concentrates.

Date	Person Counting	Count #	# Cells Counted	# mm ² Counted	Dilution Factor	# Cysts* ml	Remarks
		1					
		2					
		3					
		4					
		5					
		6					
		7					
		8					
		9					
		10					
		11					
		12					
		13					
		14					
		15					
		16					
		17					
		18					
		19					
		20					

$$* \text{ \# cysts/ml} = \frac{\text{\# of cysts counted}}{\text{\# of sq. mm counted}} \times \frac{10}{1 \text{ mm}} \times \frac{\text{dilution factor}}{1} \times \frac{1,000 \text{ mm}^3}{1 \text{ ml}}$$

Figure 3. Hemocytometer Data Sheet for Giardia Cysts

Appendix B. Preparation and Loading of Excystation Chamber Slides

1. Using tape which is sticky on both sides, cut strips approximately 12 x 3 mm.
2. Apply a strip of the tape to one side of a 22 x 22 mm coverslip.
3. Apply a second strip of tape to the opposite edge but same side of the coverslip.
4. Handling the coverslip by the edges only, attach the coverslip to the center of a 3 x 1 inch glass slide by placing the taped sides of the coverslip down along the long edge of the glass slide.
5. Make sure the coverslip is securely attached to the slide by lightly pressing down on the edges of the coverslip with your fingers. Care should be taken to keep finger prints off the center of the coverslip.
6. To load the chamber slide, place a Pasteur or microliter pipette containing at least 0.2 ml of the Giardia cyst suspension about 2 mm from an untaped edge of the coverslip. Slowly allow the cyst suspension to flow toward the coverslip. As it touches the coverslip it will be wicked or drawn rapidly under the coverslip by adhesive forces. Only expell enough of the cyst suspension to completely fill the chamber formed by the tape, slide, and coverslip.
7. Wipe away any excess cyst suspension which is not under the coverslip with an absorbant paper towel, but be careful not to pull cyst suspension from under the coverslip.
8. Seal all sides of the coverslip with vaspar to prevent the slide from drying out during the incubation.

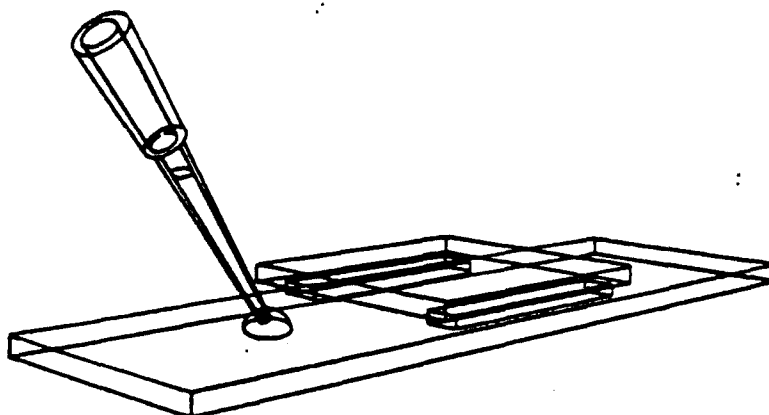

Figure 1. Excystation Chamber Slide

NOTE: Prepared excystation chamber slides may be commercially available from Spiral Systems, Inc., 6740 Clough Pike, Cincinnati, Ohio 45244, (513) 231-1211 or 232-3122, or from other sources.

78/01/90

APPENDIX G-2

DETERMINING CHLORAMINE INACTIVATION OF VIRUS
FOR THE SURFACE WATER TREATMENT RULE

Microbiological Treatment Branch
Risk Reduction Engineering Laboratory

and

Parasitology and Immunology Branch
Environmental Monitoring Systems Laboratory
U.S. Environmental Protection Agency
26 West Martin Luther King Drive
Cincinnati, Ohio 45268

TABLE OF CONTENTS

I. Materials.....	3
II. Reagents and Media.....	4
III. MS2 Bacteriophage Assay.....	6
IV. Disinfection Procedure.....	8
V. Procedure for Determining Inactivation.....	9
VI. Bibliography.....	10
VII. Technical Contacts.....	11

The Surface Water Treatment Rule requires 99.99% or greater removal/inactivation of viruses. The following protocol may be used to determine the percentage of virus inactivation obtained by a treatment plant using chloramine disinfection.

I. MATERIALS

A. Materials for Disinfection

1. Stock chlorine solution
2. Stock ammonia solution
3. Stirring device
4. Incubator or water bath for less than ambient temperature
5. Water from treatment plant
6. MS2 bacteriophage
7. Assorted glassware
8. Assorted pipettes
9. Aqueous, sterile sodium thiosulfate solution
10. Refrigerator
11. Vortex mixer
12. Timer

B. Materials for MS2 Assay

1. MS2 bacteriophage and its Escherichia coli host
2. Assorted glassware
3. Assorted pipettes
4. Incubator, 37°C
5. Refrigerator
6. Petri dishes, 100 x 15 mm, sterile
7. Vortex mixer
8. Water bath, 45°C
9. Sterile rubber spatula
10. EDTA, disodium salt
11. Lysozyme, crystallized from egg white
12. Centrifuge with swinging bucket rotor

II. REAGENTS AND MEDIA

A. Tryptone-Yeast Extract (TYE) Broth

Ingredient	Amount
Bacto tryptone	10.0 g
Yeast extract	1.0 g
Glucose	1.0 g
NaCl	8.0 g
1.0 M CaCl ₂	2.0 ml

Dissolve in distilled water to a total volume of 1.0 liter, then add 0.3 ml of 6.0 M NaOH. This medium should be sterilized either by autoclaving for 15 minutes at 121°C or filtration through a 0.22 μ m porosity membrane and then stored at approximately 4°C. It is used in preparing bacterial host suspensions for viral assays.

B. Tryptone-Yeast Extract (TYE) Agar

Ingredient	Amount
TYE broth	1.0 liter
Agar	15.0 g

The agar should be added to the broth prior to sterilization. The medium should be sterilized by autoclaving for 15 minutes at 121°C. This medium is used to prepare slant tubes for maintenance of bacterial stock cultures. The prepared slant tubes should be stored at approximately 4°C.

C. Bottom Agar for Bacteriophage Assay

Ingredient	Amount
Bacto tryptone	10.0 g
Agar	15.0 g
NaCl	2.5 g
KCl	2.5 g
1.0 M CaCl ₂	1.0 ml

Dissolve the ingredients in distilled water to a total volume of 1 liter. The medium should be sterilized by autoclaving for 15 minutes at 121°C. After autoclaving and cooling, store at 4°C. Immediately prior to use, liquefy the medium by heating. Add approximately 15 ml of liquefied agar into each Petri dish. This bottom layer serves as an anchoring substrate for the top agar layer.

D. Top Agar for Bacteriophage Assay

<u>Ingredient</u>	<u>Amount</u>
Bacto tryptone	10.0 g
Agar	8.0 g
NaCl	8.0 g
Yeast extract	1.0 g
Glucose	1.0 g
1.0 M CaCl ₂	1.0 ml

Dissolve the ingredients in distilled water to a total volume of 1 liter. This medium should be sterilized by autoclaving 15 minutes at 121°C. After cooling, store at 4°C until needed in bacteriophage assays. Immediately prior to use in assays, liquefy the medium by heating and then cool to and maintain at a temperature of 45°C.

E. Salt Diluent for Bacteriophage Assay

<u>Ingredient</u>	<u>Amount</u>
NaCl	8.5 g
1.0 M CaCl ₂	2.0 ml

Dissolve in distilled water to a total volume of 1 liter. This diluent should be sterilized either by autoclaving for 15 minutes at 121°C or filtration through a 0.22 μ m porosity membrane. Store at room temperature.

F. CaCl₂, 1.0 M

<u>Ingredient</u>	<u>Amount</u>
CaCl ₂	11.1 g

Dissolve in distilled water to a total volume of 100 ml. Autoclave 15 minutes at 121°C or filter sterilize the solution through a 0.22 μ m porosity membrane. Store at room temperature.

G. Sodium Thiosulfate, 1%

<u>Ingredient</u>	<u>Amount</u>
Sodium thiosulfate	1.0 g

Dissolve the sodium thiosulfate in 50 ml distilled water. Adjust the volume to 100 ml with additional distilled water. Filter sterilize the solution through a 0.22 μ m porosity membrane or autoclave 15 minutes at 121°C. Store at room temperature.

III. MS2 BACTERIOPHAGE ASSAY

A. Microorganisms

1. MS2 bacteriophage: catalog number 15597-B1, American Type Culture Collection, 12301 Parklawn Drive, Rockville, MD 20852
2. Bacterial host: Escherichia coli, catalog number 15597, American Type Culture Collection.

B. Growth and Maintenance of Microorganisms

1. Preparation of bacterial host stock cultures

Inoculate host bacteria onto TYE agar slant tubes, incubate 24 hours at 37°C to allow bacterial growth, and then refrigerate at 4°C. At monthly intervals the cultured bacterial hosts should be transferred to a new TYE agar slant.

2. Preparation of bacteriophage stock suspension

Melt top agar and maintain at 45°C. Add 3 ml of the agar to a 13 x 100 mm test tube contained in a rack in a 45°C water bath. Add 0.5 to 1.0 ml of the bacteriophage suspension diluted so that the host bacterial "lawn" will show nearly complete lysis after overnight incubation. Add 0.1 to 0.2 ml of a TYE broth culture of the host bacteria that has been incubated overnight. Mix gently and pour the contents on the surface of bottom agar contained in a Petri dish that has been prepared previously. Rock the Petri dish to spread the added material evenly over the agar surface. After the top agar solidifies (about 15 minutes), invert the Petri dish and incubate overnight at 37°C. Repeat the above procedure so that a minimum of 5 but no more than 10 Petri dishes are prepared.

Following this incubation and using a sterile rubber spatula, gently scrape the top and bottom agar layers into a large beaker. Add to this pool of agar layers an amount of TYE broth sufficient to yield a total volume of 80 ml. To this mixture add 0.4 g of EDTA (disodium salt) and 0.052 g of lysozyme (crystallized from egg white). Incubate this mixture at room temperature for 2 hours with continuous mixing. Then centrifuge the mixture for 15 minutes at 3,000 x g. Carefully remove the upper fluid layer. This fluid layer constitutes a viral stock suspension for use in subsequent testing and assays. The viral stock suspension may be divided into aliquots and stored either frozen or at 4°C.

C. Performance of Bacteriophage Assay

A two-week supply of Petri dishes may be poured with bottom agar ahead of time and refrigerated inverted at 4°C. If stored in a refrigerator, allow agar plates to equilibrate to room temperature

before use. Eighteen hours prior to beginning a bacteriophage assay, prepare a bacterial host suspension by inoculating 5 ml of TYE broth with a small amount of bacteria taken directly from a slant tube culture. Incubate the broth containing this bacterial inoculum overnight (approximately 18 hours) at 37°C immediately prior to use in bacteriophage assays as described below. This type of broth culture should be prepared freshly for each day's bacteriophage assays. If necessary, a volume greater than 5 ml can be prepared in a similar manner.

On the day of assay, melt a sufficient amount of top agar and maintain at 45°C in a water bath. Place test tubes (13 x 100 mm) in a rack in the same water bath and allow to warm, then add 3 ml of top agar to each tube. Inoculate the test tubes containing top agar with the bacteriophage samples (0.5 to 1.0 ml of the sample/tube) plus 0.1 to 0.2 ml of the overnight bacterial host suspension. Dilute the bacteriophage samples from 10^{-1} to 10^{-4} in salt diluent prior to inoculation and assay each dilution in triplicate. In addition, assay the uninoculated salt diluent as a negative control. Agitate the test tubes containing top agar, bacteriophage inoculum, and bacterial host suspension gently on a vortex mixer, and pour the contents of each onto a hardened bottom agar layer contained in an appropriately numbered dish. Quickly rock the Petri dishes to spread the added material evenly, and place on a flat surface at room temperature while the agar present in the added material solidifies (approximately 15 minutes). Invert and incubate the dishes at 37°C overnight (approximately 18 hours). The focal areas of viral infection which develop during this incubation are referred to as "plaques" and, if possible, should be enumerated immediately after the incubation. If necessary, the incubated Petri dishes can be refrigerated at 4°C overnight prior to plaque enumeration. As a general rule, count only those plates that contain between 20 and 200 plaques.

IV. DISINFECTION PROCEDURE

- A. The treatment plant water to be used should be the water influent into the chloramine disinfection unit process used in the plant. If chloramine disinfection is performed at more than one point in the treatment process, e.g. prefiltration and postfiltration, the procedure should simulate as closely as possible actual treatment practice.
- B. Prepare stock ammonia and chlorine solutions to be added to the treatment plant water to achieve the same stoichiometric relationship between chlorine and ammonia that is used in the water treatment plant. These solutions should be concentrated enough so that no more than 2 ml of each solution will be added to the treatment plant water being disinfected.
- C. Determine the contact time by the methods described in the Surface Water Treatment Rule and/or the associated Guidance Manual.
- D. Rinse two 600 ml beakers with treatment plant water to remove any extraneous material that may cause disinfectant demand. Then add 400 ml treatment plant water to the beaker. The first beaker will be seeded with MS2 before the contents are chloraminated. The second beaker will be an indigenous virus control and will be chloraminated without addition of extraneous phage.
- E. Mix the contents of the beaker short of producing a vortex in the center and continue until the conclusion of the experiment.
- F. Equilibrate the 600 ml beakers and their contents as well as the disinfectant reagents to the desired experimental temperature.
- G. Dilute the stock MS2 bacteriophage so that the bacteriophage concentration is 1 to 5×10^8 PFU/ml.
- H. Add 1.0 ml of the diluted MS2 bacteriophage to the contents of the first 600 ml beaker.
- I. Remove a 10 ml sample from the contents of the first beaker after 2 minutes of mixing. Assay the MS2 bacteriophage concentration in this sample within 4 hours and record the results as PFU/ml. This value is the initial MS2 concentration.
- J. Remove a 10 ml sample from the contents of the second beaker after 2 minutes of mixing. Assay the indigenous bacteriophage concentration in this sample within 4 hours (at the same time as you assay the sample from the first beaker) and record the results as PFU/ml. This value is the initial unseeded concentration.
- K. Add the disinfectant reagents to the contents of both beakers using the same sequence, time, and concentrations as are used in the actual treatment plant operations.

- L. Just prior to the end of the contact time, remove a volume of sample adequate for determination of the disinfectant residual concentration from both beakers. Use methods prescribed in the Surface Water Treatment Rule for the determination of combined chlorine. This residual should be the same ($\pm 20\%$) as the residual present in the treatment plant operation.
- M. At the end of the exposure time, remove a 10 ml sample from the first 600 ml beaker and neutralize with 0.25 ml of 1.0% aqueous, sterile sodium thiosulfate. Assay for the MS2 bacteriophage survivors and record the results as PFU/ml. This value is the exposed MS2 concentration.
- N. At the end of the exposure time, remove a 10 ml sample from the second 600 ml beaker and neutralize with 0.25 ml of 1.0% aqueous, sterile sodium thiosulfate. Assay for the indigenous bacteriophage survivors and record the results as PFU/ml. This value is the exposed unseeded concentration.

V. PROCEDURE FOR DETERMINING INACTIVATION

A. Calculation of Percentage Inactivation

Use the following formula to calculate the percent inactivation of MS2:

$$1. \quad \% \text{ inactivation} = 100\% - [(\text{exposed MS2}/\text{initial MS2}) \times 100]$$

Using values from Section IV steps I, J, M and N calculate initial MS2 and exposed MS2 as follows:

$$2. \quad \text{Initial MS2 (PFU/ml)} = I - J.$$

$$3. \quad \text{Exposed MS2 (PFU/ml)} = M - N.$$

If the number of PFU/ml in exposed MS2 is zero, i.e., no plaques are produced after assay of undiluted and diluted samples, use <1 PFU/ml as the value in the above formula.

B. Comparison of Percentage Inactivation to \log_{10} of Inactivation

68% inactivation is equivalent to 0.5 \log_{10} inactivation
 90% inactivation is equivalent to 1 \log_{10} inactivation
 99% inactivation is equivalent to 2 \log_{10} inactivation
 99.9% inactivation is equivalent to 3 \log_{10} inactivation

VI. BIBLIOGRAPHY

Adams, M.H. Bacteriophages. Interscience Publishers, New York (1959).

American Public Health Association; American Water Works Association; Water Pollution Control Federation. Standard Methods for the Examination of Water and Wastewater, 16th ed. (1985).

Grabow, W.O.K. et al. Inactivation of hepatitis A virus, other enteric viruses and indicator organisms in water by chlorination. *Water Sci. Technol.*, 17:657 (1985)

Jacangelo, J.D.; Olivieri, V.P.; & Kawata, K. Mechanism of inactivation of microorganisms by combined chlorine. AWWARF Rept., Denver, CO (1987).

Safe Drinking Water Committee. The disinfection of drinking water. In: Drinking Water and Health, National Academy Press, Washington, D.C., 2:5 (1980).

Shah, P. & McCamish, J. Relative resistance of poliovirus 1 and coliphages f₂ and T2 in water. *Appl. Microbiol.* 24:658 (1972).

U.S. Environmental Protection Agency. Guidance Manual for Compliance with the Filtration and Disinfection Requirements for Public Water Systems Using Surface Water Sources. Appendix G. U.S. EPA, Office of Water, Criteria and Standards Division, Washington, D.C. (1988).

Ward, N.R.; Wolfe, R.L.; & Olson, B.H. Effect of pH, application technique, and chlorine-to-nitrogen ratio on disinfectant activity of inorganic chloramines with pure culture bacteria. *Appl. Environ. Microbiol.*, 48:508 (1984).

VII. TECHNICAL CONTACTS:

A. Donald Berman
Microbiological Treatment Branch
Risk Reduction Engineering Laboratory
U.S. Environmental Protection Agency
26 West Martin Luther King Drive
Cincinnati, Ohio 45268

Phone: (513) 569-7235

B. Christon J. Hurst
Microbiological Treatment Branch
Risk Reduction Engineering Laboratory
U.S. Environmental Protection Agency
26 West Martin Luther King Drive
Cincinnati, Ohio 45268

Phone: (513) 569-7331

G.3 DETERMINING CHLORINE DIOXIDE INACTIVATION OF GIARDIA CYSTS AND VIRUS

Giardia Cysts

The basis for the chlorine dioxide CT values for Giardia cysts in the Guidance Manual is given in Appendix F.1.2. The CT values are based on data collected mainly at pH 7. Very little data was available at other pHs. A review of data from Hoff (1986) indicates that the disinfection efficiency of chlorine dioxide for bacteria and viruses increases approximately 2 to 3 fold as pH increases from 7 to 9. Data on which the CT values in the SWTR are based indicate that at 25 C, G. muris cyst inactivation CTs were approximately 2 fold higher at pH 7 than at pH 9 (Leahy, 1985). In addition, the data also indicate that chlorine dioxide efficiency increases as disinfectant concentration increases within the range studied.

Because the data on effects of chlorine dioxide concentration and water pH on Giardia cyst inactivation efficiency were very limited, they were not considered in calculating the Giardia cyst CT values in Appendix E. However, the data suggest that site specific conditions, i.e. water pH and disinfectant concentration, can have significant effects on chlorine dioxide effectiveness. Therefore, the option of allowing the Primacy Agency to consider the use of lower CT values by individual systems has been provided.

This approval should be based on acceptable experimental data provided by the system. The data should be collected using the protocol provided in Appendix G-1 for determining Giardia cyst inactivation by chloramine with appropriate changes in Section IV A, B, I and J to reflect the use of chlorine dioxide rather than chloramines. This procedure can be used for any disinfectant which can be prepared in an aqueous solution and is stable over the course of the testing. To do this, chloramine should be replaced with the test disinfectant in the above noted sections.

Virus

The basis for the chlorine dioxide CT values for virus in Appendix F.2.2 consists of limited data from Sobsey (1988). Because the pH 9 data available were very limited, the CT values are based on the pH 6 data with a safety factor of 2 applied. As indicated previously, review of data from a number of studies (Hoff, 1986) shows that chlorine dioxide efficiency increases 2 to 3 fold as pH increases from 7 to 9.

Because the virus CT values for chlorine dioxide are very conservative and most systems operate at water pHs higher than those on which the CT values are based, the option of allowing the Primacy Agency to consider the use of lower CT values has been provided.

This approval should be based on acceptable experimental data provided by the system. The data should be collected using the protocol provided in Appendix G.2 with appropriate changes in Sections I A, 1 and 2 and IV A, B, D, K, and L to reflect the use of chlorine dioxide rather than chloramines. This procedure can be used for any disinfectant which can be prepared in an aqueous solution and is stable over the course of the testing. To do this, chloramine should be replaced with the test disinfectant in the above noted sections.

REFERENCES

Hoff, J.C. Inactivation of Microbial Agents By Chemical Disinfectants, EPA/600/52-86/067, U.S. Environmental Protection Agency, Water Engineering Research Laboratory, Cincinnati, Ohio, September, 1986.

Leahy, J.G. Inactivation of Giardia Muris Cysts by Chlorine and Chlorine Dioxide. Thesis, Department of Civil Engineering, Ohio State University, 1985.

Sobsey, M.D. Detection and Chlorine Disinfection of Hepatitis A Virus in Water. CR813024, EPA Quarterly Report, Dec. 1988.

G.4 DETERMINING OZONE INACTIVATION OF GIARDIA CYSTS AND VIRUS

G.4.1 BACKGROUND

The basis for the ozone CT values are given in Appendices F.1.2 (Giardia cysts) and F.2.4 (Virus). As indicated, both sets of CT values are based on limited data and because of this, the values established are conservative and employ large safety factors. In addition, the difference between the way the laboratory experiments used to develop the CT values and how ozone is used in water treatment presents a problem with translating the data for field use. The laboratory studies were conducted using steady state ozone concentrations with ozone continually added during the contact period. In contrast, steady state ozone concentrations are not maintained in field use. Also, the effectiveness of ozone contactors used in field applications may vary from each other and from the mixing efficiencies applied in the laboratory experiments used to establish the CT values.

The net effect of all of these differences is to limit the applicability of the CT values in the SWTR and Guidance Manual to individual systems. Therefore, the option of allowing the Primacy Agency to consider the use of lower CT values by individual systems has been provided.

This approval should be based on acceptable experimental data provided by the system. In general, the procedures provided in Appendix G.1 for determining Giardia cyst inactivation and Appendix G.2 for determining virus inactivation can be used. However, unlike chloramines ozone is not a stable disinfectant. Because of ozone's rapid dissipation, a pilot study must be used in lieu of the batch system to demonstrate the disinfection efficiency. General considerations for conducting pilot studies to demonstrate the disinfection ability of ozone or any other unstable disinfectant are enumerated below.

G.4.2 GENERAL CONSIDERATIONS FOR PILOT TEST

- A. All microorganisms, reagents and media are prepared as indicated in sections G.1 for Giardia and G.2 for virus.

- B. The disinfectant should be prepared, measured and added to the test water as it would be added to the water at the water treatment plant.
- C. Specific reactor design should be a function of the disinfectant and reflect how the disinfectant is added at the water treatment plant. Provisions should be made to determine concentration of disinfectant and microbial survival to be measured with contact time.

An example of conducting a pilot test for a plug flow reactor using ozone or another unstable disinfectant is provided below.

Example - Plug Flow Reactor Protocol

The size of the plug flow reactor can be approximated from the table below. Glass, stainless steel, copper, plastic tubing or other material compatible with the disinfectant can be used to construct the plug flow reactor. Table 1 shows the approximate length of pipe for a plug flow reactor to yield 10 minutes contact at flow rates between 50 and 500 ml/min. Depending on pipe size and material an economical reactor can be constructed.

TABLE 1. APPROXIMATE LENGTH AND DIAMETER OF PIPE
BASED ON FLOW

FLOW ml/min	TIME MIN.	VOLUME LITERS	CC	LINEAR PIPE LENGTH, METERS NOMINAL PIPE DIAMETER, CM					
				0.6 0.28	1.2 1.31	1.8 2.54	2.54 5.07	3.81 11.40	5.08 20.27
50	10	0.5	500	17.7	4.4	2.0	1.0	0.4	0.2
100	10	1	1000	35.4	8.8	3.9	2.0	0.9	0.5
200	10	2	2000	70.7	17.7	7.9	3.9	1.8	1.0
300	10	3	3000	106.1	26.5	11.8	5.9	2.6	1.5
400	10	4	4000	141.5	35.4	15.7	7.9	3.5	2.0
500	10	5	5000	176.8	44.2	19.6	9.9	4.4	2.5

Additional information on the design of specific pilot studies can be found in the following references by Thompson (1982), Montgomery (1985), and Al-Ani (1985).

Additional Materials to those in G.1 and/or G.2

plug flow reactor
cyst suspension, 2×10^7 cysts/trial

cyst quantity - cysts are prepared as indicated in G.1.

10^3 cysts/ml X 20,000 ml = 2×10^7 cysts required/trial.

MS2 stock, 2×10^{10} /trial

2-20 liter (5 gal) carboy

test water pump, mid range 200 ml/min

disinfectant generator

disinfectant pump, mid range 10-20 ml/min

disinfectant residual reagents and equipment

Test Procedure

A. Reactor conditions

1. Test Water Flow rate= 200 ml/min (this may vary from 50 to 500 ml/min with 20 l reservoir total experimental time= 100 min)
2. Disinfectant flow
gas-requires specific contactor designed for disinfectant
Liquid=10 to 20 ml/min
3. Temperature
controlled
4. Prepare 20 liter reservoir (5 gal) of test water at the pH and temperature of the CT trial. Do not add microorganisms
5. Prepare 20 liter reservoir (5 gal) of test water and equilibrate to the temperature of the CT trial. Add Giardia muris cysts at an initial density of 10^3 cysts/ml and/or MS2 bacterial virus at an initial density of 10^6 PFU/ml. Mix thoroughly and adjust pH to the pH of the CT trial. Continuous mixing of the test water feed stock should be carried out over the course of the CT trial to prevent the Giardia cysts from settling.

B. Disinfection Procedure - Prior to Disinfection Trial

1. Determine contact time for the sample ports in the plug flow reactor under conditions of the CT trial by methods described in the SWTR.
2. Determine disinfectant concentration with no microorganisms in the feed test water.

C. CT Trial Procedure

1. Start test water feed without cysts and or virus (approx. 200 ml/min), start disinfectant feed (gas or liquid).

Allow system to equilibrate.

Monitor disinfectant residual by appropriate method during this time. Samples for disinfectant residual should be taken directly into tubes or bottles containing reagents to fix the disinfectant at the time the sample is collected. Keep a plot of disinfectant residual vs running time to evaluate steady state conditions.

2. After the disinfectant residual has stabilized, switch to the reservoir containing the test microorganism(s).
3. Allow system to equilibrate for a time = 3 X final contact time.

example

final contact time = 10 min, allow 30 min.

4. Monitor disinfectant residual by appropriate method during this time. If the disinfectant residual is stable begin chemical and biological sampling for calculation of CT.
5. Sampling

a. Chemical

A sufficient volume (about 250 ml) should be collected from the sampling tap prior to the biological composite to determine:

pH

Residual disinfectant - Samples

should be collected directly

into tubes or bottles containing

reagents to fix the disinfectant

at the time the sample is collected.

b. Biological

Samples for microbial analysis are collected as short time composite samples over a 10 to 20 minute time period. Several trials may run for a given 20 liter test water preparation as long as sufficient equilibra-

tion and flow recovery times are allowed between trials.

- Zero time samples should be collected as 250 ml composite samples either directly from the test water feed reservoir or in line prior to the addition of the disinfectant.
- Four 250 ml samples are collected separately into a 2 l sterile bottle containing a neutralizing agent for the particular disinfectant. Each sample is thoroughly mixed upon collection and stored at 4 C. If multiple sample ports are used, the order of collection should be from longest to shortest contact time to minimize flow changes due to sampling.

6. Giardia cyst recovery and assay.

Concentrate the 1000 ml composite sample by filtration according to the method given in section G.1. Record and report the data as described in section G.1. The expected cysts/sample is given below:

$$\text{Cysts/sample} = 4 \times 250 \text{ ml} \times 10^3 \text{ cyst/ml} = 1 \times 10^6 \text{ cyst/sample.}$$

7. Virus Assay

Before filtration for Giardia, remove 10.0 ml from the biological composite sample to a sterile screw cap culture tube containing 2 to 3 drops chloroform. Assay for MS2, record and report the virus data according to the methods and procedures described in G.2. Be sure to correct the Giardia sample volume to 990 ml.

8. Calculation of CT

Calculate CT in a manner described in Section G.1 for Giardia and Section G.2 for virus. The residual disinfectant should be the average of the four residual determinations performed prior to the individual samples collected for the biological composite and the time should be the time determined for the sample port under similar flow conditions.

REFERENCES

Al-Ani, C.S.U., Filtration of Giardia Cysts and other substances: Volume 3. Rapid Rate Filtration (EPA/600/2-85/027) 1985.

Montgomery, James M. Consulting Engineers Inc., Water Treatment Principles and Design, John Wiley and Sons, May 1982.

Wallis, P.M., Davies, J.S., Nuthonn, R., Bichanin-Mappin, J.M., Roach, P.D., and Van Roodeloon, A. Removal and Inactivation of Giardia Cysts in a Mobile Water Treatment Plant Under Field Conditions: Preliminary Results. In Advances in Giardia Research. P.M. Wallis and B.R. Hammand, eds, Union of Calgary Press, p. 137-144, 1989.

Wolfe, R.L., Stewart, M.H., Liange, S.L., and McGuire, M.J., Disinfection of Model Indicator Organisms in a Drinking Water Pilot Plant by Using PEROXONE, Applied Environmental Microbiology, Vol 55, 1989, pp 2230-2241.

Olivieri, V.P. and Sykora, J.L., Field and Evaluation of CT for Determining the Adequacy of Disinfection. American Water Works Association Water Quality Technology Conference. In press, 1989.

APPENDIX H

**SAMPLING FREQUENCY FOR TOTAL COLIFORMS
IN THE DISTRIBUTION SYSTEM**

TABLE H-1

**TOTAL COLIFORM SAMPLING REQUIREMENTS
BASED UPON POPULATION**

<u>Population Served</u>	<u>Minimum Number of Samples Per Month</u> (1,2,3)	<u>Population Served</u>	<u>Minimum Number of Samples Per Month</u>
25 to 1,000	1	59,001 to 70,000	70
1,001 to 2,500	2	70,001 to 83,000	80
2,501 to 3,300	3	83,001 to 96,000	90
3,301 to 4,100	4	96,001 to 130,000	100
4,101 to 4,900	5	130,001 to 220,000	120
4,901 to 5,800	6	220,001 to 320,000	150
5,801 to 6,700	7	320,001 to 450,000	180
6,701 to 7,600	8	450,001 to 600,000	210
7,601 to 8,500	9	600,001 to 780,000	240
8,501 to 12,900	10	780,001 to 970,000	270
12,901 to 17,200	15	970,001 to 1,230,000	300
17,201 to 21,500	20	1,230,001 to 1,520,000	330
21,501 to 25,000	25	1,520,001 to 1,850,000	360
25,001 to 33,000	30	1,850,001 to 2,270,000	390
33,001 to 41,000	40	2,270,001 to 3,020,000	420
41,001 to 50,000	50	3,020,001 to 3,960,000	450
50,001 to 59,000	60	3,960,001 or more	480

Notes:

1. Non-community systems using all or part surface water and community systems must monitor total coliform at this frequency. A non-community water system using ground water and serving 1,000 persons or fewer must monitor quarterly, beginning 5 years after the rule's promulgation, although this can be reduced to yearly if a sanitary survey shows no defects. A non-community water system serving more than 1,000 persons during any month, or a non-community water system using surface water, must monitor at the same frequency as a like-sized community public water system for each month the system provides water to the public.
2. Unfiltered surface water systems must analyze one coliform sample each day the turbidity exceeds 1NTU.

TABLE H-1

TOTAL COLIFORM SAMPLING REQUIREMENTS
BASED UPON POPULATION (Continued)

3. Systems collecting fewer than 5 samples per month on a regular basis must conduct sanitary surveys. Community and non-community systems must conduct the initial sanitary surveys within 5 and 10 years of promulgation, respectively. Subsequent surveys must be conducted every 5 years, except for non-community systems using protected and disinfected ground water, which have up to 10 years to conduct subsequent surveys.

TABLE H-2

MONITORING AND REPEAT SAMPLE FREQUENCY

<u>System Size</u>	<u># Routine Samples</u>	<u># Repeats</u>	<u>More Monitoring For</u>
NCWS ⁽¹⁾	Quarterly ⁽²⁾	4	5/mo for 1 additional mo
25 - 1,000	Monthly ⁽²⁾	4	5/mo for 1 additional mo
1,001 - 2,500	2/mo	3	5/mo for 1 additional mo
2,501 - 3,300	3/mo	3	5/mo for 1 additional mo
3,301 - 4,100	4/mo	3	5/mo for 1 additional mo
4,101 - 4,900	5/mo	3	None
>4,900	Table 1	3	None

Notes:

1. Non-community Water systems.
2. For exceptions, see Table 1.

APPENDIX I
MAINTAINING REDUNDANT
DISINFECTION CAPABILITY

APPENDIX I
REDUNDANT DISINFECTION CAPABILITY

The SWTR requires that unfiltered water systems provide redundant disinfection components to ensure the continuous application of a disinfectant to the water entering the distribution system. In many systems, both filtered and unfiltered, a primary disinfectant is used to provide the overall inactivation/removal and a secondary residual is applied to maintain a residual in the distribution system. As outlined in Sections 3.2.4 and 5.5.4, redundancy of the disinfection system(s) is recommended to ensure that the overall treatment requirement of 3-log Giardia cyst and 4-log virus removal/inactivation is achieved, and a residual is maintained entering the distribution system. This is particularly important for unfiltered supplies where the only treatment barrier is disinfection. Redundancy of components is necessary to allow for disinfection during routine repairs, maintenance and inspection and possible failures.

In reviewing water disinfection facilities for compliance with redundancy requirements, the following items should be checked:

I. General

- A. Are the capacities of all components of both the primary system and the backup system equal to or greater than the required capacities?

Some systems may have two or more units that provide the required dosage rates when all units are operating. In these cases, an additional unit is needed as backup, during the downtime of any of the operating units. The backup must have a capacity equal to or greater than that of the largest on-line unit.

- B. Are adequate safety precautions being followed, relative to the type of disinfectant being used?
- C. Are redundant components being exercised or alternated with the primary components?
- D. Are all components being properly maintained?
- E. Are critical spare parts on hand to repair disinfection equipment?

- F. Are spare parts available for components that are indispensable for disinfecting the water?

II. Disinfectant Storage

A minimum of two storage units capable of being used alternately should be provided. The total combined capacity of the storage units should provide as a minimum the system design capacity.

A. Chlorine

Storage for gaseous chlorine will normally be in 150-lb cylinders, 2,000-lb containers, or larger on-site storage vessels.

1. Is there automatic switchover equipment if one cylinder or container empties or becomes inoperable?
2. Is the switching equipment in good working order, (manually tested on a regularly scheduled basis), and are spare parts on hand?
3. Are the scales adequate for at least two cylinders or containers.

B. Hypochlorite

Storage of calcium hypochlorite or sodium hypochlorite is normally provided in drums or other suitable containers. Redundancy requirements are not applicable to these by themselves, as long as the required minimum storage quantity is on hand at all times.

C. Ammonia

Anhydrous ammonia is usually stored in cylinders as a pressurized liquid. Aqua ammonia is usually stored as a solution of ammonia and water in a horizontal pressure vessel.

1. Is the available storage volume divided into two or more usable units?
2. Is automatic switching equipment in operation to change over from one unit to another when one is empty or inoperable?
3. Are there spare parts for the switching equipment?

III. Generation

Ozone and chlorine dioxide are not stored on-site. Rather, because of their reactivity, they are generated and used immediately.

To satisfy the redundancy requirements for these disinfectants it is recommended that two generating units, or two sets of units, capable of supplying the required feed rate be provided. In systems where there is more than one generation system, a standby unit should be available for times the on-line units need repair. The backup unit should have a capacity equal to or greater than the unit(s) it may replace.

A. Chlorine Dioxide

Chlorine, sodium chlorite, or sodium hypochlorite should be stored in accordance with storage guidelines previously described.

B. Ozone

Are all generation components present and in working order for both the primary and the redundant units (whether using air or oxygen)?

C. Common

Is switchover and automatic start-up equipment installed and operable to change from the primary generating unit(s) to the redundant unit(s)?

IV. Feed Systems

Redundancy in feed systems requires two separate units, or systems, each capable of supplying the required dosage of disinfectant. If more than one unit is needed to apply the required feed rate, a spare unit should be available to replace any of the operating units during times of malfunction. The replacement unit should, therefore, have a capacity equal to or greater than that of the largest unit which it may replace. This requirement applies to all disinfection methods, and is best implemented by housing the on-line and redundant components in separate rooms, enclosures, or areas, as appropriate.

In reviewing these systems for redundancy, the following components should be checked:

A. Chlorine

1. Evaporators
2. Chlorinators
3. Injectors

B. Hypochlorite

1. Mixing tanks and mixers
2. Chemical feed pumps and controls
3. Injectors

C. Ozone

1. Dissolution equipment, including compressor and delivery piping systems

D. Chlorine Dioxide

1. Chlorine feed equipment
2. Sodium chlorite mixing and metering equipment
3. Day tank and mixer
4. Metering pumps
5. If a package ClO₂ unit is used, two must be provided

E. Chloramination

1. Chlorine feed equipment
2. Ammonia feed equipment, including applicable equipment for either:
 - a. Anhydrous ammonia (gas)
 - b. Aqua ammonia (solution)

V. Residual Monitoring

The best method of monitoring a disinfection facility for continuous operation is by continuous recording equipment. To improve reliability, it is suggested that duplicate continuous monitors are present for backup in the event of monitor failure. However, if there is a failure in the monitoring system for indicating that a continuous residual is being maintained, the SWTR allows systems to take grab samples every four hours for up to five days during monitor repair. For systems without 24 hour staffing it will not be practical to take grab samples and redundant monitoring equipment is recommended. Failure of continuous monitoring would be a violation of a monitoring requirement, not a treatment requirement.

A. Chlorine

1. Does the facility have a continuous monitor for chlorine residual at the disinfection system site with an alarm

or indicator to show when the monitor is not functioning? For added assurance, the provision of a backup monitoring unit is also recommended.

2. Is there instrumentation in place to automatically switch from one monitor to the other if the first one fails?

B. Hypochlorite

Same as for chlorine system.

C. Ozone

1. Does the facility have a continuous ozone monitor with automatic switchover capability and alarms?
2. Does the facility have a continuous ozone residual monitor with automatic switchover capability and alarms?

D. Chlorine Dioxide

1. Does the facility have a continuous chlorine dioxide monitor with automatic switchover capability and alarms?
2. Does the facility have a continuous chlorine dioxide residual monitor with automatic switchover capability and alarms?

E. Chloramination

1. Does the facility have a continuous ammonia monitor with automatic switchover capability and alarm?
2. Does the facility also have a continuous chlorine residual monitor on-site with automatic switchover capability and alarms?

VI. Power Supply

A permanently installed standby generator, capable of running all electrical equipment at the disinfection station, and equipped for automatic start-up on power failure, should be on-site and functional.

Alternatives to a standby generator, such as a feed line from a different power source, are acceptable if they can be shown to have equal reliability.

VII. Alarms

Indicators and alarms, both local and remote, should be capable of promptly alerting operating and supervisory personnel of problem conditions.

A. Local

Lights, buzzers, and horns should be installed and functioning to alert on-site personnel to problem conditions.

B. Remote

Alarm signals should be relayed to a central control panel which is manned 24 hours per day and whose operators can notify response personnel immediately.

C. Problem Conditions

A minimum list of problem conditions which should have indicators and alarms, both locally and at a 24-hour per day switchboard, are as follows:

1. Disinfectant leak
2. Feeder pump failure
3. Power outage
4. Generator or alternate power source on
5. Disinfectant residual less than setpoint value

VIII. Facility Layout

Maximum reliability is ensured when redundant units are separated from primary units. The type of separation should be appropriate to the type of potential malfunction. For example, any area within a building subject to a chlorine leak should have primary components separated from redundant components by an airtight enclosure, i.e., separate rooms of varying sizes.

IX. Separate Facility

Under certain conditions, such as location of a disinfection facility in an area of high earthquake potential, the most reliable means of providing redundant facilities may be to house them in a completely separate structures at a different site.

APPENDIX J
WATERSHED CONTROL PROGRAM

APPENDIX J
WATERSHED CONTROL PROGRAM

The following is a guideline for documenting a watershed control program. The SWTR only requires a watershed control program for unfiltered supplies. A watershed control program can also benefit a filtered system by providing protection for maintaining the source water quality, minimizing the level of disinfection to be provided. It is therefore recommended that all systems conduct the basic elements of a watershed control program. However, the scope of the program should increase as the complexity and size of the watershed/ system increases. The program could be more or less comprehensive than this outline, and will be determined on a case-by-case basis by the utility and the Primacy Agency. In addition to the guidelines below, a wellhead protection program could be the basis of a watershed control program in many states. All of the elements found below would also be part of a local wellhead protection program.

A. Watershed Description

1. Geographical location and physical features of the watershed.
2. Location of major components of the water system in relationship to the watershed.
3. Hydrology: Annual precipitation patterns, stream flow characteristics, etc.
4. Agreements and delineation of land use/ownership.

B. Identification of the Watershed Characteristics and Activities Detrimental to Water Quality

1. Naturally Occurring:
 - a. Effect of precipitation, terrain, soil types and land cover
 - b. Animal populations (describe) -- include a discussion of the Giardia contamination potential, any other microbial contamination transmitted by animals

- c. Other - any other activity which can adversely affect water quality

2. Man-Made:

- a. Point sources of contamination such as wastewater treatment plant, industrial discharges, barnyard, feedlots, or private septic systems

The impact of these sources on the microbiological quality of the water source should be evaluated. In cases resulting in identifiable degradation, the discharges should be eliminated in order to minimize the treatment of the water needed.

- b. Nonpoint Source of Contamination:

- 1) Road construction - major highways, railroads
- 2) Pesticide usage
- 3) Logging
- 4) Grazing animals
- 5) Discharge to ground water which recharges the surface source
- 6) Recreation activities
- 7) Potential for unauthorized activity in the watershed
- 8) Describe any other human activity in the watershed and its potential impact on water quality

It should be noted that grazing animals in the watershed may lead to the presence of Cryptosporidium in the water. Cryptosporidium is a pathogen which may result in a disease outbreak upon ingestion. No information is available on its resistance to various disinfectants, therefore it is recommended that grazing should not be permitted on watersheds of non-filtering systems. Sewage discharges will introduce viruses into the water source which may be occluded in solids and protected from inactivation through disinfection. It is, therefore, recommended that sewage discharges should not be permitted within watersheds of non-filtering supplies. Although it is preferable to not have grazing or sewage discharges within the watershed, Primacy Agencies will

need to evaluate the impact of these activities on a case-by-case basis. In cases where there is a long detention time and a high degree of dilution between the point of the activity and the water intake, these activities may be permissible for unfiltered supplies. The utility should set priorities to address the impacts in B.1. and 2., considering their health significance and the ability to control them.

C. Control of Detrimental Activities/Events

Depending on the activities occurring within the watershed, various techniques could be used to eliminate or minimize their effect. Describe what techniques are being used to control the effect of activities/events identified in B.1. and 2. in its yearly report.

Example:

Activity: Logging in the watershed.

Management Decision: Develop program to minimize impact of logging.

Procedure: Establish agreements with logging companies to maintain practices which will minimize adverse impacts on water quality. These practices should include:

- limiting access to logging sites
- ensuring cleanup of sites
- controlling erosion from site.

Monitoring: Periodically review logging practices to ensure they are consistent with the agreement between the utility and the logging companies.

Example:

Activity: Point sources of discharge within the watershed.

Management Decision: Eliminate those discharges or minimize their impact.

Procedures: Actively participate in the review of discharge permits to alert the reviewing agency of the potential (actual) impacts of the discharge and lobby for its elimination or strict control.

Monitoring: Conduct special monitoring to ensure conditions of the permit are met and to document adverse effects on water quality.

D. Monitoring

1. **Routine:** Minimum specifications for monitoring several raw water quality parameters are listed in Section 3.1. Describe when, where and how these samples will be collected. These results will be used to evaluate whether the source may continue to be used without filtration.
2. **Specific:** Routine monitoring may not provide information about all parameters of interest. For example, it may be valuable to conduct special studies to measure contaminants suspected of being present (*Giardia*, pesticides, fuel products, enteric viruses, etc.). Frequent presence of either *Giardia* or enteric viruses in raw water samples prior to disinfection would indicate an inadequate watershed control program. Monitoring may also be useful to assess the effectiveness of specific control techniques, and to audit procedures or operational requirements instituted within the watershed. Utilities are encouraged to conduct additional monitoring as necessary to aid them in controlling the quality of the source water.

E. Management/Operations

1. **Management**
 - a. Organizational structure
 - b. Personnel and education/certification requirements
2. **Operations**
 - a. Describe system operations and design flexibility.
 - b. The utility should conduct some form of ongoing review or survey in the watershed to identify and react to potential impacts on water quality. The scope of this review should be documented and agreed upon by the utility and Primacy Agency on a case-by-case basis.
 - c. Specifically describe operational changes which can be made to adjust for changes in water quality. Example: Switching to alternate sources; increasing the level of disinfection; using

settling basins. Discuss what triggers, and who decides to make, those changes.

3. Annual Report: As part of the watershed program, an annual report should be submitted to the Primacy Agency. The contents of the report should:
 - a. Identify special concerns that occurred in the watershed and how they were handled (example: herbicide usage, new construction, etc.).
 - b. Summarize other activities in the watershed such as logging, hunting, water quality monitoring, etc.
 - c. Project what adverse activities are expected to occur in the future and describe how the utility expects to address them.

F. Agreements/Land Ownership

The goal of a watershed management program is to achieve the highest level of raw water quality practicable. This is particularly critical to an unfiltered surface supply.

1. The utility will have maximum opportunity to realize this goal if they have complete ownership of the watershed. Describe efforts to obtain ownership, such as any special programs or budget. When complete ownership of the watershed is not practical, efforts should be taken to gain ownership of critical elements, such as, reservoir or stream shoreline, highly erodable land, and access areas to water system facilities.
2. Where ownership of land is not possible, written agreements should be obtained recognizing the watershed as part of a public water supply. Maximum flexibility should be given to the utility to control land uses which could have adverse effect on the water quality. Describe such agreements.
3. Describe how the utility ensures that the landowner complies with these agreements.

APPENDIX K
SANITARY SURVEY

APPENDIX K
SANITARY SURVEY

The SWTR requires that an on-site inspection be conducted each year as outlined in Section 3. It is recommended that at the onset of determining the classification of a source water that a detailed sanitary survey be conducted. In addition, it is recommended that a sanitary survey such as contained in this appendix be conducted every 3 to 5 years by both filtered and unfiltered systems to ensure that the quality of the water and service is maintained. This time period is suggested since the time and effort needed to conduct the comprehensive survey makes it impractical for it to be conducted annually. A periodic sanitary survey is also required under the Total Coliform Rule for systems collecting fewer than 5 samples/month. The survey must be conducted every 5 years for all systems except for protected ground water systems which disinfect. These systems must conduct the survey every 10 years.

The sanitary survey involves three phases, including planning the survey, conducting the survey and compiling the final report of the survey, as will be presented in the following pages.

1. Planning the Survey

Prior to conducting or scheduling a sanitary survey, there should be a detailed review of the water system's file to prepare for the survey. The review should pay particular attention to past sanitary survey reports and correspondence describing previously identified problems and their solutions. These should be noted, and action/inaction regarding these problems should be specifically verified in the field. Other information to review includes: any other correspondence, water system plans, chemical and microbiological sampling results, operating reports, and engineering studies. This review will aid in the familiarization with the system's past history and present conditions, and the agency's past interactions with the system.

The initial phase of the water quality review will be carried out prior to conducting the survey as well, and will consist of reviewing the water system's monitoring records. Records should be reviewed for compliance with all applicable microbiological, inorganic chemical, organic chemical, and radiological contaminant MCLs, and also for compliance with the monitoring requirements for those contaminants. The survey

will provide an opportunity to review these records with the utility, and to discuss solutions to any MCL or monitoring violations. The survey will also provide an opportunity to review how and where samples are collected, and how field measurements (turbidity, chlorine residual, fluoride, etc.) are made. Points to cover include:

- a. Is the system in compliance with all applicable MCLs (organic chemical, inorganic chemical, microbiological, and radiological)?
- b. Is the system in compliance with all monitoring requirements?

The pre-survey file review should generate a list of items to check in the field, and a list of questions about the system. It will also help to plan the format of the survey and to estimate how much time it may take. The next step is to make the initial contact with the system management to establish the survey date(s) and time. Any records, files, or people that will be referenced during the survey should be mentioned at the outset. Clearly laying out the intent of the survey up front will greatly help in managing the system, and will ensure that the survey goes smoothly without a need for repeat trips.

2. Conducting the Survey

The on-site portion of the survey is the most important and will involve interviewing those in charge of managing the water system as well as the operators and other technical people. The survey will also review all major system components from the source(s) to the distribution system. A standard form is frequently used to ensure that all major components and aspects of each system are consistently reviewed. However, when in the field, it is best to have an open mind and focus most attention on the specifics of the water system, using the form only as a guide. The surveyor should be certain to be on time when beginning the survey. This consideration will help get the survey started smoothly with the operator and/or manager.

As the survey progresses, any deficiencies that are observed should be brought to the attention of the water system personnel, and the problem and the corrective measures should be discussed. It is far better to clarify technical details and solutions while standing next to the problem than it is to do so over the telephone. Points to cover include:

- a. Is the operator competent in performing the necessary field testing for operational control?

- b. Are testing facilities and equipment adequate, and do reagents used have an unexpired shelf life?
- c. Are field and other analytical instruments properly and regularly calibrated?
- d. Are records of field test results and water quality compliance monitoring results being maintained?
- e. Conduct any sampling which will be part of the survey.

Also, detailed notes of the findings and conversations should be taken so that the report of the survey will be an accurate reconstruction of the survey.

Specific components/features of the system to review and some pertinent questions to ask are:

A. Source Evaluation

All of the elements for a source evaluation enumerated below may also be part of a Wellhead Protection Program.

1. Description: based on field observations and discussion with the operator, a general characterization of the watershed should be made. Features which could be included in the description are:
 - a. Area of watershed or recharge area.
 - b. Stream flow.
 - c. Land usage (wilderness, farmland, rural housing, recreational, commercial, industrial, etc.).
 - d. Degree of access by the public to watershed.
 - e. Terrain and soil type.
 - f. Vegetation.
 - g. Other.
2. Sources of contamination in the watershed or sensitive areas surrounding wells or well fields should be identified. Not only should this be determined by physically touring and observing the watershed and its daily uses, but the surveyor should also actively question the water system manager about adverse and potentially adverse

activities in the watershed. An example of types of contamination includes:

a. Man Made.

1. Point discharges of sewage, storm-water, and other wastewater.
2. On-site sewage disposal systems.
3. Recreational activities (swimming, boating, fishing, etc.).
4. Human habitation.
5. Pesticide usage.
6. Logging.
7. Highways or other roads from which there might be spills.
8. Commercial or industrial activity.
9. Solid waste or other disposal facilities.
10. Barnyards, feed lots, turkey and chicken farms and other concentrated domestic animal activity.
11. Agricultural activities such as grazing, tillage, etc., which affects soil erosion, fertilizer usage, etc.
12. Other.

b. Naturally Occurring.

1. Animal populations, both domestic and wild.
2. Turbidity fluctuations (from precipitation, landslides, etc.).
3. Fires.
4. Inorganic contaminants from parent materials (e.g., asbestos fibers).
5. Algae blooms.

6. Other.

This list is by no means all inclusive. The surveyor should rely principally on his observations and thorough questioning regarding the unique properties of each watershed to completely describe what may contaminate the source water.

3. Source Construction.

a. Surface Intakes.

1. Is the source adequate in quantity?
2. Is the best quality source or location in that source being used?
3. Is the intake protected from icing problems if appropriate?
4. Is the intake screened to prevent entry of debris, and are screens maintained?
5. Is animal activity controlled within the immediate vicinity of the intake?
6. Is there a raw water sampling tap?

b. Infiltration Galleries.

1. Is the source adequate in quantity?
2. Is the best quality source being used?
3. Is the lid over the gallery watertight and locked?
4. Is the collector in sound condition and maintained as necessary?
5. Is there a raw water sampling tap?

c. Springs.

1. Is the source adequate in quantity?
2. Is there adequate protection around the spring such as fencing to control the area within 200 feet?

3. Is the spring constructed to best capture the spring flow and exclude surface water infiltration?
4. Are there drains to divert surface water from the vicinity of the spring?
5. Is the collection structure of sound construction with no leaks or cracks?
6. Is there a screened overflow and drain pipe?
7. Is the supply intake located above the floor and screened?
8. Is there a raw water sampling tap?

d. Catchment and Cistern.

1. Is source adequate in quantity?
2. Is the cistern of adequate size?
3. Is the catchment area protected from potential contamination?
4. Is the catchment drain properly screened?
5. Is the catchment area and cistern of sound construction and in good condition?
6. Is catchment constructed of approved non-toxic, non-leaching material?
7. Is the cistern protected from contamination -- manholes, vents, etc?
8. Is there a raw water tap?

e. Other Surface Sources.

1. Is the source adequate in quantity?
2. Is the best possible source being used?
3. Is the immediate vicinity of the source protected from contamination?

4. Is the structure in good condition and properly constructed?
 5. Is there a raw water sampling tap?
4. Pumps, Pumphouses, and Controls.
 - a. Are all intake pumps, booster pumps, and other pumps of sufficient capacity?
 - b. Are all pumps and controls operational and maintained properly?
 - c. Are check valves, blow off valves, water meters and other appurtenances operated and maintained properly?
 - d. Is emergency power backup with automatic start-up provided and does it work (try it)?
 - e. Are underground compartments and suction wells waterproof?
 - f. Is the interior and exterior of the pumphouse in good structural condition and properly maintained?
 - g. Are there any safety hazards (electrical or mechanical) in the pumphouse?
 - h. Is the pumphouse locked and otherwise protected against vandalism?
 - i. Are water production records maintained at the pumphouse?
 5. Watershed Management (controlling contaminant sources): The goal of the watershed management program is to identify and control contaminant sources in the watershed (see Section 3.3.1 of this document, "Watershed Control Program"). Under ideal conditions each source of contamination identified in 2 will already have been identified by the utility, and some means of control instituted, or a factual determination made that its impact on water quality is insignificant. To assess the degree to which the watershed management program is achieving its goal, the following types of inquiries could be made:

- a. If the watershed is not entirely owned by the utility, have written agreements been made with other land owners to control land usage to the satisfaction of the utility? Are appropriate regulations under the contract of state/local department of health in effect?
- b. Is the utility making efforts to obtain as complete ownership of the watershed as possible? Is effort directed to control critical elements?
- c. Are there means by which the watershed is regularly inspected for new sources of contamination or trespassers where access is limited?
- d. Are there adequately qualified personnel employed by the utility for identifying watershed and water quality problems and who are given the responsibility to correct these problems?
- e. Are raw water quality records kept to assess trends and to assess the impact of different activities and contaminant control techniques in the watershed?
- f. Has the system responded adequately to concerns expressed about the source or watershed in past sanitary surveys?
- g. Has the utility identified problems in its yearly watershed control reports, and if so, have these problems been adequately addressed?
- h. Identify what other agencies have control or jurisdiction in the watershed. Does the utility actively interact with these agencies to see that their policies or activities are consistent with the utility's goal of maintaining high raw water quality?

B. Treatment Evaluation

1. Disinfection.

- a. Is the disinfection equipment and disinfectant appropriate for the application (chloramines, chlorine, ozone, and chlorine

dioxide are generally accepted disinfectants)?

- b. Are there back-up disinfection units on line in case of failure, and are they operational?
- c. Is there auxiliary power with automatic start up in case of power outage? Is it tested and operated on a regular basis, both with and without load?
- d. Is there an adequate quantity of disinfectant on hand and is it properly stored (e.g., are chlorine cylinders properly labeled and chained)?
- e. In the case of gaseous chlorine, is there automatic switch over equipment when cylinders expire?
- f. Are critical spare parts on hand to repair disinfection equipment?
- g. Is disinfectant feed proportional to water flow?
- h. Are daily records kept of disinfectant residual near the first customer from which to calculate CTs?
- i. Are production records kept from which to determine CTs?
- j. Are CTs acceptable based on the level of treatment provided (see Surface Water Treatment Rule for CT values, and Sections 3 and 5 of this guidance manual for calculation of CT).
- k. Is a disinfectant residual maintained in the distribution system, and are records kept of daily measurements?
- l. If gas chlorine is used, are adequate safety precautions being followed (e.g., exhaust fan with intake within six inches of the floor, self-contained breathing apparatus that is regularly tested, regular safety training for employees, ammonia bottles and/or automatic chlorine detectors)? Is the system adequate to ensure

the safety of both the public and the employees in the event of a chlorine leak?

2. Other.

- a. Are other treatment processes appropriate and are they operated to produce consistently high water quality?
- b. Are pumps, chemical feeders, and other mechanical equipment in good condition and properly maintained?
- c. Are controls and instrumentation adequate for the process, operational, well maintained and calibrated?
- d. Are accurate records maintained (volume of water treated, amount of chemical used, etc.)?
- e. Are adequate supplies of chemical on hand and properly stored?
- f. Are adequate safety devices available and precautions observed?

Sections of a sanitary survey pertaining to systems containing filtration facilities have been omitted, as this section of the guidance document pertains to non-filtering systems.

C. Distribution System Evaluation

After water has been treated, water quality must be protected and maintained as it flows through the distribution system to the customer's tap. The following questions pertain to the water purveyor's ability to maintain high water quality during storage and distribution.

1. Storage.

a. Gravity.

1. Are storage reservoirs covered and otherwise constructed to prevent contamination?
2. Are all overflow lines, vents, drainlines, or cleanout pipes turned downward and screened?

3. Are all reservoirs inspected regularly?
4. Is the storage capacity adequate for the system?
5. Does the reservoir (or reservoirs) provide sufficient pressure throughout the system?
6. Are surface coatings within the reservoir in good repair and acceptable for potable water contact?
7. Is the hatchcover for the tank watertight and locked?
8. Can the reservoir be isolated from the system?
9. Is adequate safety equipment (caged ladder, OSHA approved safety belts, etc.) in place for climbing the tank?
10. Is the site fenced, locked, or otherwise protected against vandalism?
11. Is the storage reservoir disinfected after repairs are made?
12. Is there a scheduled program for cleaning storage reservoir sediments, slime on floor and side walls.

b. **Hydropneumatic.**

1. Is the storage capacity adequate for the system?
2. Are instruments, controls, and equipment adequate, operational, and maintained?
3. Are the interior and exterior surfaces of the pressure tank in good condition?
4. Are tank supports structurally sound?
5. Does the low pressure cut in provide adequate pressure throughout the entire system?

6. Is the pump cycle rate acceptable (not more than 15 cycles/hour)?

2. Cross Connections.

- a. Is the system free of known uncontrolled cross connections?
- b. Does the utility have a cross connection prevention program, including annual testing of backflow prevention devices?
- c. Are backflow prevention devices installed at all appropriate locations (wastewater treatment plant, industrial locations, hospitals, etc.)?

3. Other.

- a. Are proper pressures and flows maintained at all times of the year?
- b. Do all construction materials meet AWWA or equivalent standards?
- c. Are all services metered and are meters read?
- d. Are plans for the system available and current?
- e. Does the system have an adequate maintenance program?
 - Is there evidence of leakage in the system?
 - Is there a pressure testing program?
 - Is there a regular flushing program?
 - Are valves and hydrants regularly exercised and maintained?
 - Are AWWA standards for disinfection followed after all repairs?
 - Are there specific bacteriological criteria and limits prescribed for new line acceptance or following line repairs?

- Describe the corrosion control program.
- Is the system interconnected with other systems?

D. Management/Operation

1. Is there an organization that is responsible for providing the operation, maintenance, and management of the water system?
2. Does the utility regularly summarize both current and long-term problems identified in their watershed, or other parts of the system, and define how they intend to solve the problems i.e., is their planning mechanism effective; do they follow through with plans?
3. Are customers charged user fees and are collections satisfactory?
4. Are there sufficient personnel to operate and manage the system?
5. Are personnel (including management) adequately trained, educated, and/or certified?
6. Are operation and maintenance manuals and manufacturers technical specifications readily available for the system?
7. Are routine preventative maintenance schedules established and adhered to for all components of the water system?
8. Are sufficient tools, supplies, and maintenance parts on hand?
9. Are sufficient operation and maintenance records kept and readily available?
10. Is an emergency plan available and usable, and are employees aware of it?
11. Are all facilities free from safety defects?

When the survey is completed, it is always preferable to briefly summarize the survey with the operator(s) and management. The main findings of the survey should be reviewed so it is clear that there are not misunderstandings about findings/conclusions. It is also good

to thank the utility for taking part in the survey, arranging interviews with employees, gathering and explaining their records, etc. The information and help which the utility can provide an invaluable to a successful survey, and every attempt should be made to continue a positive relationship with the system.

3. Reporting the Survey

A final report of the survey should be completed as soon as possible to formally notify the system and other agencies of the findings. There is no set or necessarily best format for doing so, and the length of the report will depend on the findings of the survey and size of the system. Since the report may be used for future compliance actions and inspections, it should include as a minimum: 1) the date of the survey; 2) who was present during the survey; 3) the findings of the survey; 4) the recommended improvements to identified problems; and 5) the dates for completion of any improvements. Any differences between the findings discussed at the conclusion of the survey and what's included in the final report should be discussed and clarified with the utility prior to sending out the final report. In other words, the utility should be fully aware of the contents of the final report before receiving it.

APPENDIX L
SMALL SYSTEM CONSIDERATIONS

APPENDIX L
SMALL SYSTEM CONSIDERATIONS

Introduction

Under the provisions of the SWTR, systems with fewer than 500 service connections may be eligible for an exemption. Guidance on the requirements for an exemption is provided in Section 9. For systems which are not eligible for an exemption, compliance with the SWTR is mandatory. It is recognized that the majority (approximately 75 percent) of people in the United States are served by a relatively small number of large systems. However, most water systems in the United States are small. For small systems, compliance with the various provisions of the SDWA has traditionally been a problem. Records show small systems have a disproportionately higher incidence of drinking water quality and monitoring difficulties. The reasons for these difficulties can generally be broken down into the following three categories:

- Economics
- Treatment Technologies
- Operations (lack of qualified personnel)

Small water systems typically face severe economic constraints. Their lack of operating revenues results in significant limitations on their ability to respond to the requirements of the SDWA. These systems cannot benefit from the economies of scale which are available to larger systems.

The second difficulty facing the small systems has been the lack of appropriate treatment technologies. Although methods for removing most of the contaminants known to occur in drinking water are available, many of these technologies have only recently been scaled down for the smaller systems.

The third problem which has traditionally plagued small systems is the lack of well trained operators. This deficiency is the result of many combined factors. First of all, many of these operators are employed only on a part-time basis or if they are employed on a full-time basis they have a myriad of additional duties. In addition, the operator's technical

background may be limited as well. This results from the low salary of the position, which is uninviting to qualified operators. Also, in spite of the requirement of retaining certified operators upheld in many states, it seems to be difficult to enforce this requirement in small systems.

The purpose of this appendix is to provide assistance to the Primacy Agency in defining the problems and potential solutions typically associated with small systems. It is beyond the scope of this document to provide an indepth dicussion of the needs of small systems. However, over the past several years the needs of the small water systems have been recognized to be of primary concern and numerous workshops, seminars and committees have been attempting to more clearly define workable solutions. A partial listing of the papers, reports and proceedings which discuss problems and solutions pertaining to small systems beyond that which is possible in this manual is presented in the reference list of this appendix.

Economics

One of the most severe constraints of small systems is the small economic base from which to draw funds. Certain treatment and services must be provided for a community regardless of how few people are served. Thus, as the number of connections to the system decrease, the cost per connection increases. The economic limitations of small utilities makes it difficult to provide needed upgrading of existing facilities or an adequate salary to maintain the employment of a qualified operator to monitor and maintain the system. Adding to the severity of the economic hardships of small systems is the fact that many of the small water systems are privately owned, with private ownership increasing as system size decreases. The ownership of the plant presents difficulties since privately owned systems are subject to rate controls by the local public utility commission, are not eligible for public grants and loans, and may find commercial loans hard to obtain.

Financing options for small systems include; federal and state loan and grant programs, federal revenue sharing and revenue bonds (for municipal systems) and loans through the United States Small Business Administration (SBA) and use of industrial development bonds or privatiza-

tion (for private utilities). These options are explained in greater detail in the "Guidance Manual - Institutional Alternatives for Small Water Systems" (AWWA, 1986). The following paragraphs will explain some existing options which may ease the hardship of financing small water treatment facilities.

The major cause of small system difficulties arises from the lack of funds and resources. It is therefore in the best interest of small utilities to expand their economic base and the resources available to them, to achieve the economies of scale available to larger systems. Regionalization is the physical or operational union of small systems to effect this goal. This union can be accomplished through the physical interconnection of two or more small systems or the connection of a smaller system to a pre-existing larger system. Water supply systems can also join together for the purchase of supplies, materials, engineering services, billing and maintenance. The union of the small systems increases the population served, thereby dispersing the operational costs and decreasing the cost per consumer.

The creation of utility satellites is another form of regionalization. A satellite utility is one which taps into the resources of an existing larger facility without being physically connected to, or owned by, the larger facility. The larger system may provide any of the following for the smaller system:

1. Varying levels of technical operational, or managerial assistance on a contract basis.
2. Wholesale treated water with or without additional services.
3. Assuming ownership, operation and maintenance responsibility when the small system is physically separate with a separate source.

The formation of a satellite offers many advantages for both the satellite and the parent utility. These advantages include: an improved economy of scale for satellites, an expanded revenue base for the parent utility, provisions of needed resources to satellites, the retention of the satellites' local autonomy, improved water quality management of the satellite, improved use of public funds for publicly owned satellites.

In order to create a more definite structure for the union of resources of water treatment facilities, water districts may be created. Water districts are formed by county officials and provide for the public ownership of the utilities. The utilities in any given district would combine resources and/or physically connect systems so that one or two facilities would provide water for the entire district. The creation of water districts creates eligibility for public monies, has the potential for economies of size, facilitates the takeover or contract services with publicly owned non-community systems and small privately owned systems, and offers a tax advantage. Drawbacks include subjection to politics, a strong local planning effort is needed for success, and competition with private enterprises.

The centralization of utilities can be taken one step further through the creation of county utilities or even state utilities. The government will create a board which may then act to acquire, construct, maintain and operate any public water supply within its district, the system may provide water on its own or purchase water from any municipal corporation. The board may adopt and administer rules for the construction, maintenance, protection and use of public water supplies and the fixation of reasonable rates for water supplies. The cost of construction and/or upgrading of facilities may be defrayed through the issuance of bonds and/or property assessment. As with all the alternatives, the creation of government control of the utilities has its advantages and disadvantages. The advantages include: the creation of central management, creation of economy of scale for utilities, eligibility for public grants and loans, savings through centralized purchasing, management, consultation, planning and technical assistance, and possible provision for pool of trained operators. The disadvantages include the subjectivity to politics, the slow response caused by bureaucracy, and competition to private contractors.

Treatment Technologies

The high cost of available treatment technologies has limited their use in small water supply systems. Recently prefabricated package plants and individual treatment units have been developed to lessen these costs.

At the present time, the treatment technologies which are available to enable systems to comply with the Safe Drinking Water Act are identified to be the following:

- Package plants
- Slow-sand filters
- Diatomaceous earth filters
- Cartridge filtration

A brief discussion of each treatment method is provided below.

Package Plants

Clarification and filtration units which require minimal assembly in the field can now be manufactured. To minimize required operator skill level and operational attention, the equipment should be automated. Continuous effluent turbidity and disinfectant residual monitoring systems with alarms and emergency shutdown provisions are features that safeguard water quality and should be provided for unattended plants.

Slow-Sand Filters

Slow-sand filters are applicable to small water supply systems. Their proven record of effective removal of turbidity and Giardia cysts makes them suitable for application where operational attention is minimal. Since no chemicals other than a disinfectant are needed, and no mechanical equipment is involved, the required operator skill level is the lowest of the filtration alternatives available to small systems.

Diatomaceous Earth Filters

Diatomaceous earth (DE) pressure and vacuum filters can be used on relatively low turbidity surface waters (less than 1 to 2 NTU) for removal of turbidity and Giardia cysts. DE filters can effectively remove particles as small as 1 micron, but would require coagulating chemicals and special filter aids to provide significant virus removal.

Cartridge Filters

Cartridge filters using microporous ceramic filter elements with pore sizes as small as 0.2 μm may be suitable for producing potable water, in combination with disinfection, from raw water supplies containing moderate levels of turbidity, algae, protozoa and bacteria. The advantage to a small system, is, with the exception of chlorination, that no other chemicals are required. The process is one of strictly physical removal

of small particles by straining as the water passes through the porous membranes. Other than occasional cleaning or membrane replacement, operational requirements are not complex and do not require skilled personnel.

Selection of a Filtration Technology

The criteria for selection of a filtration technology for a small community are essentially the same as those for a larger community. That is, the utility must first screen the complete list of available alternatives to eliminate those which are either not technically suited to the existing conditions (Table 4-1) or not affordable by the utility. Remaining alternatives should then be evaluated based on both cost (capital, annual, and life-cycle) and non-cost bases (operation and maintenance, technical requirements versus personnel available; flexibility regarding future needs; etc.). In these evaluations it should be noted that even though automated package plants are cost-competitive with slow sand filters, their operation requirements to achieve optimum performance could be complicated. Also, the maintenance requirements for package plants would be mechanically and electrically oriented and might require a maintenance agreement with the manufacturer.

During the process of installing the treatment system, interim measures should be taken to ensure the delivery of a reasonably safe water to the consumers. In addition to the available interim measures listed in Section 9.3, temporary installation of mobile filtration plants may be possible. These trailer-mounted units are sometimes available from state agencies for emergencies, but more often may be rented or leased from an equipment manufacturer.

Modification of Existing Filtration Systems

Small treatment systems that are already in existence should comply with the performance criteria of the SWTR. If the systems are not found to be performing satisfactorily, modifications to the existing process may be required. Improvement in treatment efficiency depends on the type of filtration system in use. Operation of slow sand filters could be checked for bed depth, short-circuiting, excessive hydraulic loading, and for the need to pretreat the raw water. Infiltration galleries, or sometimes, roughing filters ahead of a slow sand filter may provide for better

performance by reducing the solids load on the filters. However, the design criteria and costs for this alternative have not yet been defined. Site specific studies may be required before roughing filters could be used to achieve compliance with the regulations. Diatomaceous earth (DE) filters should be checked for appropriate precoat and body feed application, hydraulic loading, grade (size) of DE being used, and possible need for chemical pretreatment. Package plants would have to be checked process-by-process, similar to the system used for a conventional plant. Other filtration processes would have to be checked for hydraulic loading rate, appropriateness of the filter material (pore size), and possible need for additional pretreatment.

Disinfection

Disinfection (CT) requirements for small systems can be met in several different ways. The most obvious method of maintaining a disinfectant residual in the distribution system is to add disinfectant at one or more additional locations. An alternate method is to increase the disinfectant dose at the existing application point(s). The latter alternative, however, may increase disinfectant byproducts, including THMs, in the system.

If it is a relatively short distance between the treatment system and the first customer, additional contact time can be provided so that the disinfectant dose does not have to be increased beyond desirable residuals. Two specific methods of increasing contact time for small systems are 1) installing a pressure vessel or closed storage vessel, baffled to provide adequate contact time, or 2) constructing a looped pipeline, on the finished water line between the filtration-disinfection system and the first customer. The feasibility of either of these methods would depend on system specifics that include size, physical conditions, and cost.

If it is not practical to provide additional storage time to achieve the desired CT, an alternate, more effective disinfectant may be used. An alternate disinfectant may provide a sufficient CT without altering the system configuration.

Operations

Water treatment facilities need to be operated properly in order to achieve maximum treatment efficiencies. There is currently a lack of well trained operators at many small treatment plants. The main cause is lack of awareness of the importance of correct plant operation, lack of training programs, lack of enforcement of the requirement for employment of a certified operator and lack of funds to employ such an operator.

Small systems may wish to implement a circuit rider/operator program. In this program a qualified, certified, experienced operator works for several water supply systems. The rider can either directly operate the plants, or provide technical assistance to individual plant operators, by acting as a trainer through on-the-job supervision. The latter would be preferable since it could create a pool of well trained operators.

The main cause of inadequately trained operators is the lack of well established training programs. Until such training programs are begun, systems must depend on other training means, such as seminars and books. One resource which may be helpful in running the plant is "Basic Management Principles for Small Water Systems - An AWWA Small-Systems Resource Book", 1982.

Most package plant manufacturers' equipment manuals include at least brief sections on operating principles, methods for establishing proper chemical dosages, instructions for operating the equipment, and troubleshooting guides. An individual who studies these basic instructions and receives comprehensive start-up training should be able to operate the equipment satisfactorily. These services are vital to the successful performance of a package water treatment plant and should be a requirement of the package plant manufacturer. The engineer designing a package plant facility should specify that start-up and training services be provided by the manufacturer, and also should consider requiring the manufacturer to visit the plant at 6-month and 1-year intervals after start-up to adjust the equipment, review operations, and retrain operating personnel. Further, this program should be ongoing and funds should be budgeted every year for at least one revisit by the package plant manufacturer.

Another way for small systems to obtain qualified plant operation would be to contract the services of administrative, operations, and/or maintenance personnel from a larger neighboring utility, government agencies, service companies or consulting firms. These organizations could supply assistance in financial and legal planning, engineering, purchasing accounting and collection services, laboratory support, licensed operators or operator training, treatment and water quality assurance, regulatory liaison, and/or emergency assistance. Through the contracting of these services the utility provides for the resources needed, improves water quality management and retains its autonomy. However, if and when the contract is terminated, the utility returns to its original status.

References

American Water Works Association. Basic Management Principles for Small Water Systems, 1982.

American Water Works Association. Design and Construction of Small Water Systems, 1984.

Kelly, Gidley, Blair and Wolfe, Inc. Guidance Manual - Institutional Alternatives for Small Water Systems. AWWA Research Foundation Contract 79-84, 1986.

APPENDIX M
PROTOCOL FOR DEMONSTRATION
OF EFFECTIVE TREATMENT

APPENDIX M

PROTOCOL FOR DEMONSTRATION OF EFFECTIVE TREATMENT

This appendix presents approaches which can be taken to demonstrate overall effective removal and/or inactivation of Giardia cysts.

M.1 Demonstration for Alternate Technology

Systems using a filtration technology other than those enumerated in the SWTR may demonstrate the effectiveness of the treatment process through pilot or full scale testing. As a minimum, testing should be conducted when the source exhibits its worst case annual conditions. Some systems may have two periods of "worst case" water quality including the cold water in winter or algae blooms during the summer.

Pilot units should include the following:

- filtration rate of the pilot system equal to filtration rate on full scale unit
- pilot filter diameter greater than or equal to 50 times the media diameter, (Robeck, et al 1959)
- media diameter, depth, and size gradation should be identical to full scale,
- coagulant dosing identical to full scale
- any mixing and settling occurring before filtration in the full scale plant should be reproduced as closely as possible in the pilot. Mixing should be of the same G value(s), and the detention time for settling should be close to the average flow detention time for the projected full scale plant.

According to the SWTR, alternate technologies must be capable of meeting the same turbidity performance criteria of slow sand filtration systems. Thus the filtered water from the process should be monitored continuously or with grab samples every four hours for turbidity. The requirement for meeting turbidity performance has been established to

ensure that there will be no interference of turbidity with virus inactivation through disinfection.

Following the demonstration of meeting the turbidity requirements, the level of Giardia cyst removal achieved must be determined. The protocol in M.2 may be followed for this demonstration.

M.2 Particle Size Analysis Demonstration for Giardia Cyst Removal Credit

Particle size analysis may be used to demonstrate the level of actual Giardia cyst removal provided by the system. This demonstration can be done using samples from the full scale plant or a pilot unit.

In the case of either a full scale or pilot scale demonstration, removal of particles in the range of 5 to 15 μm in diameter should be determined using an electronic particle counter that has been calibrated with latex spheres. If a light blockage device is used (e.g. HIAC) this calibration should have been done during installation of the device. The calibration should be checked before taking measurements for the purposes of this demonstration. Samples should be diluted appropriately to ensure that measurements do not reflect coincident error. Coincident error results when more than one particle passes the detector at one time, causing an inaccurate particle count and diameter measurement. An electrical sensing zone device (e.g. Coulter Counter or Elzone) may also be used. Appropriate dilutions, electrolyte strength, and calibration procedures should be followed (these are scheduled to be outlined in the 17th edition of Standard Methods). When using an electrical sensing zone instrument, an orifice no larger than 125 μm and no smaller than 40 μm should be used since only particles between 2% and 40% of the orifice diameter are accurately sized and counted (Karuhn et al 1975).

Samples of the filter influent and effluent should be taken 5 minutes after the backwashed filter is placed in operation, and every 30 minutes thereafter for the first 3 hours of operation, followed by hourly samples up until backwash (Wiesner et al 1987). All samples should show at least a 2-log removal. The SWTR establishes an overall treatment requirement of 3-log Giardia cyst removal/inactivation. Thus, disinfection

tion must be provided to supplement the particulate removal and meet this requirement.

Samples from repeated filter runs may be averaged at each sampling time, but samples should not be averaged within one filter run.

Additional suggestions on particle counting technique (Wiesner 1985):

- 1) If particle counts are not determined immediately upon sampling (within 10 minutes) samples should be diluted.
- 2) For an electrical sensing zone measurement, samples should be diluted 1:5 to 1:20 with a "particle-free" electrolyte solution (approximately 1% NaCl) containing 100 particles per ml or fewer.
- 3) For a light blockage measurement, particle free water should be used to dilute samples.
- 4) Dilutions should be done to produce particle concentrations as close to the tolerance for coincident error as possible to minimize background counts.
- 5) Particle counts should be determined within 8 hours of sampling.
- 6) All sampling vessels should be washed with laboratory detergent, double rinsed in particle free water, and rinsed twice with the water being sampled at the time of sampling.

The log reduction of particles in the size range of 5 to 15 um in size can be assumed to correspond to the log reduction of Giardia cysts which would be achieved.

M.3 Demonstration for Increased Turbidity Allowance

Based upon the requirements of the SWTR, the minimum turbidity performance criteria for systems using conventional treatment or direct filtration is filtered water turbidity less than or equal to 0.5 NTU in 95 percent of the measurements taken each month. However, at the discretion of the Primacy Agency, filtered water turbidity levels of less than or equal to 1 NTU in 95 percent of the measurements taken every month

may be permitted on a case-by-case basis depending on the capability of the total system to remove and/or inactivate at least 99.9 percent of Giardia lamblia cysts.

Treatment plants that use settling followed by filtration, or direct filtration are generally capable of producing a filtered water with a turbidity of 0.2 NTU or less. The most likely cause of high turbidities in the filtered water is incorrect coagulant dosing (O'Melia, 1974). Regardless of the turbidity of the raw or finished water, coagulant addition at some point prior to filtration is required to destabilize particles for removal in the filter. Only plants documenting continuous coagulant feed prior to filtration should be eligible for being allowed higher filtered water turbidities than the 0.5 NTU requirement. At plants that continuously feed coagulant and do not meet the 0.5 NTU requirement, a series of jar tests, and perhaps sand column filtration tests (in batch) should be performed to evaluate the optimum coagulant dose for turbidity removal.

In the event that plants can document continuous coagulant feed, and, after running the plant under conditions determined in batch testing to be optimal for turbidity removal, still do not meet the 0.5 NTU requirement, effective filtration status may still be appropriate. This would further be supported if it can be shown that the full scale plant is capable of achieving at least a 2-log reduction in the concentration of particles between 5 and 15 μm in size through particle size analysis as outlined in Section M.2. Where a full scale plant does not yet exist, appropriately scaled-down pilot filters might be used for such a demonstration.

Disinfection

The level of disinfection could also be considered for determining when to allow a higher turbidity performance criterion for a system. For example, if a system achieves 3-log Giardia cyst inactivation through disinfection, as determined by CT values, it may be appropriate to allow higher filtered water turbidities (i.e., greater than 0.5 NTU but less than 1 NTU in 95 percent of the measurements and never exceeding 5 NTU).

The expected level of fecal contamination and Giardia cyst concentrations in the source water should be considered in the above analysis. High levels of disinfection (e.g., 2 to 3-log inactivation of Giardia cysts), in addition to filtration which achieves less than 0.5 NTU in 95 percent of the measurements may be appropriate, depending upon source water quality. Further guidance on the level of disinfection to be provided for various source water conditions is provided in Section 4.4.2. In all cases the minimum disinfection to be provided must supplement the particulate removal to ensure at least a 3-log Giardia cyst removal/inactivation.

References

American Public Health Association; American Water Works Association; Water Pollution Control Federation. Standard Methods for the Examination of Water and Wastewater, 17th ed. (supplement), September 1989.

Coulter Electronics 600 W. 20th Street, Hialeah, FL 33010-2428

Karuhn, R.; Davies, R.; Kaye, B.; Clinch, M. Studies on the Coulter Counter Part I. Powder Technology Volume II, pp. 157-171, 1975.

O'Melia, C. The Role of Polyelectrolytes in Filtration Processes, EPA - 67012-74-032, 1974.

Robeck, G.; Woodward, R. L. Pilot Plants for Water Treatment Research, Journal of Sanitary Engineering ASCE Vol. 85;SA4; 1, August 1959.

Wiesner, M. "Optimum Water Treatment Plant Configuration Effects of Raw Water Characteristics," dissertation John Hopkins University, Baltimore, MD, 1985.

Wiesner, M.; Rook, J. J.; Fiessinger, F. Optimizing the Placement of GAC Filters, J. AWWA VOL 79, pp. 39-49, Dec 1987.

APPENDIX N
PROTOCOLS FOR POINT-OF-USE
DEVICES

Preface

The protocol presented in this paper can be applied to demonstrate the effectiveness of new technologies as well as point-of-use devices. The evaluation presented here deals with the removal of particulates and disinfection. In areas which pertain to disinfection, the guidelines contained in Appendix G take precedence.

CONTENTS

	<u>Page</u>
PREFACE	
1. GENERAL	N-1
2. PERFORMANCE REQUIREMENTS	N-6
3. MICROBIOLOGICAL WATER PURIFIER TEST PROCEDURES	N-8
APPENDIX N-1 SUMMARY FOR BASIS OF STANDARDS AND TEST WATER PARAMETERS	N-21
APPENDIX N-2 LIST OF PARTICIPANTS IN TASK FORCE	N-29
APPENDIX N-3 RESPONSE BY REVIEW SUBCOMMITTEE TO PUBLIC COMMENTS	N-31

**UNITED STATES
ENVIRONMENTAL PROTECTION AGENCY**

**Registration Division
Office of Pesticide Programs
Criteria and Standards Division
Office of Drinking Water**

**GUIDE STANDARD AND PROTOCOL FOR
TESTING MICROBIOLOGICAL WATER PURIFIERS**

**Report of Task Force
Submitted April, 1986
Revised April, 1987**

1. GENERAL

1.1 Introduction

The subject of microbiological purification for waters of unknown microbiological quality repeatedly presents itself to a variety of governmental and non-governmental agencies, consumer groups, manufacturers and others. Examples of possible application of such purification capabilities include:

- Backpackers and campers
- Non-standard military requirements
- Floods and other natural disasters
- Foreign travel and stations (however, not for extreme contamination situations outside of the U.S.)
- Contaminated individual sources, wells and springs (however, not for the conversion of waste water to microbiologically potable water)
- Motorhomes and trailers

Batch methods of water purification based on chlorine and iodine disinfection or boiling are well known, but many situations and personal choice call for the consideration of water treatment equipment. Federal agencies specifically involved in responding to questions and problems relating to microbiological purifier equipment include:

- Registration Division, Office of Pesticide Programs (OPP), Environmental Protection Agency (EPA): registration of microbiological purifiers (using chemicals);
- Compliance Monitoring Staff, EPA: control of microbiological purifier device claims (non-registerable products such as ultra-violet units, ozonators, chlorine generators, others);
- U.S. Army Medical Bioengineering Research and Development Laboratory (USAMBRDL), U.S. Army Natick Research and Development Center and other Army and military agencies: research and development for possible field applications;
- Criteria and Standards Division, Office of Drinking Water (ODW), EPA: Consideration of point-of-use technology as acceptable technology under the Primary Drinking Water Regulations; consumer information and service;

- Drinking Water Research, Water Engineering Research Laboratory (WERL), EPA; responsible for water treatment technology research;
- Microbiology Branch, Health Effects Research Laboratory (HERL), EPA; responsible for study of health effects related to drinking water filters.

A number of representatives of the above mentioned agencies provided excellent participation in the task force to develop microbiological testing protocols for water purifiers. Major participation was also provided by the following:

- A technical representative from the Water Quality Association;
- A technical representative from the Environmental Health Center, Department of Health and Welfare of Canada; and
- An associate professor (microbiology) from the University of Arizona.

1.2 Basic Principles

1.2.1 Definition

As set forth in EPA Enforcement Strategy and as supported by a Federal Trade Commission (FTC) decision (FTC v. Sibco Products Co., Inc., et al., Nov. 22, 1965), a unit, in order to be called a microbiological water purifier, must remove, kill or inactivate all types of disease-causing microorganisms from the water, including bacteria, viruses and protozoan cysts so as to render the processed water safe for drinking. Therefore, to qualify, a microbiological water purifier must treat or remove all types of challenge organisms to meet specified standards.

1.2.2 General Guide

The standard and protocol will be a general guide and, in some cases, may present only the minimum features and framework for testing. While basic features of the standard and protocol have been tested, it was not feasible to conduct full-fledged testing for all possible types of units. Consequently, protocol users should include pre-testing of their units in a testing rig, including the sampling techniques to be used. Where users of the protocol find good reason to alter or add to the guide in order to meet specific operational problems, to use an alternate organism or laboratory procedure, or to respond to innovative treatment units without decreasing the level of

testing or altering the intent of the protocol, they should feel free to do so. For example, the OPP Registration Division might find it necessary to amend the guide somewhat for different types of treatment units. Another example would be ultraviolet (U.V.) units, which may have specific requirements in addition to the guide protocol.

1.2.3 Performance-Based

The standard will be performance-based, utilizing realistic worst case challenges and test conditions and use of the standard shall result in water quality equivalent to that of a public water supply meeting the microbiological requirements and intent of the National Primary Drinking Water Regulations.

1.2.4 Exceptions

A microbiological water purifier must remove, kill or inactivate all types of pathogenic organisms if claims are made for any organism. However, an exception for limited claims may be allowed for units removing specific organisms to serve a definable environmental need (i.e., cyst reduction units which can be used on otherwise disinfected and microbiologically safe drinking water, such as a disinfected but unfiltered surface water containing cysts. Such units are not to be called microbiological water purifiers and should not be used as sole treatment for an untreated raw water.)

1.2.5 Not to Cover Non-Microbiological Reduction Claims

The treatment of water to achieve removal of a specific chemical or other non-microbiological substances from water will not be a part of this standard. National Sanitation Foundation (NSF) Standards 42 (Aesthetic Effects) and 53 (Health Effects) provide partial guides for chemical removal and other claims testing.

1.2.6 Construction and Information Exclusions

While the standard recommends safe, responsible construction of units with non-toxic materials for optimum operation, all such items and associated operational considerations are excluded as being beyond the scope of the standard. Included in the exclusion are materials of construction, electrical and safety aspects, design and construction details, operational instructions and information, and mechanical performance testing.

1.2.7 Research Needs Excluded

The guide standard and protocol must represent a practical testing program and not include research recommendations. For example, consideration of mutant organisms or differentiation between injured and dead organisms would be research items at this time and not appropriate for inclusion in the standard.

1.2.8 Not to Consider Sabotage

Esoteric problems which could be presented by a variety of hypothetical terrorist (or wartime) situations, would provide an unnecessary complication, and are not appropriate for inclusion in the standard.

1.2.9 Continuity

The guide standard and protocol will be a living document, subject to revision and updating with the onset of new technology and knowledge. It is recommended that the responsible authorities for registration and drinking water quality review potential needs every two to three years and reconvene the task force upon need or upon request from the water quality industry, to review and update the standard and testing protocol.

1.3 Treatment Units Coverage

1.3.1 Universe of Possible Treatment Units

A review of treatment units that might be considered as microbiological purifiers discloses a number of different types covering treatment principles ranging from filtration and chemical disinfection to ultraviolet light radiation.

1.3.2 Coverage of This Standard

In view of the limited technical data available and in order to expedite the work of the task force, the initial coverage is limited, on a priority basis, to three basic types of microbiological water purifiers or active components with their principal means of action as follows:

1.3.2.1 Ceramic Filtration Candles or Units (may or may not contain a chemical bacteriostatic agent)

Filtration, and adsorption, and chemical anti-microbial activity if a chemical is included.

1.3.2.2 Halogenated Resins and Units

Chemical disinfection and possibly filtration. (Note: While not included in this guide standard, halogen products for disinfection or systems using halogen addition and fine filtration may be tested using many of its elements, i.e., test water parameters, microbiological challenge and reduction requirements, analytical techniques and other pertinent elements.)

1.3.2.3 Ultraviolet (UV) Units

UV irradiation with possible add-on treatment for adsorption and filtration (not applicable to UV units for treating potable water from public water supply systems).

1.3.3 Application of Principles to Other Units

While only three types of units are covered in this standard, the principles and approaches outlined should provide an initial guide for the testing of any of a number of other types of units and/or systems for the microbiological purification of contaminated water.

2. PERFORMANCE REQUIREMENTS

2.1 Microbiological Water Purifier

In order to make the claim of "microbiological water purifier," units must be tested and demonstrated to meet the microbiological reduction requirements of Table 1 according to the test procedures described in Section 3 (Appendix N-1) for the specific type of unit involved.

2.2 Chemical Health Limits

Where silver or some other pesticidal chemical is used in a unit, that chemical concentration in the effluent water must meet any National Primary Drinking Water Maximum Contaminant Level (MCL), additional Federal guidelines or otherwise be demonstrated not to constitute a threat to health from consumption or contact where no MCL exists.

2.3 Stability of Pesticidal Chemical

Where a pesticidal chemical is used in the treatment unit, the stability of the chemical for disinfectant effectiveness should be sufficient for the potential shelf life and the projected use life of the unit based on manufacturer's data. Where stability cannot be assured from historical data and information, additional tests will be required.

2.4 Performance Limitations

2.4.1 Effective Lifetime

The manufacturer must provide an explicit indication or assurance of the unit's effective use lifetime to warn the consumer of potential diminished treatment capability either through:

- a. Having the unit terminate discharge of treated water, or
- b. Sounding an alarm, or
- c. Providing simple, explicit instruction for servicing or replacing units within the recommended use life (measurable in terms of volume throughput, specific time frame or other appropriate method).

2.4.2 Limitation on Use of Iodine

EPA policy initially developed in 1973 and reaffirmed in 1982 (memo of March 3, 1982 from J. A. Cotruvo to G. A. Jones, subject: "Policy on Iodine Disinfection") is that iodine disinfection is acceptable for short-term or limited or emergency use but that it is not recommended for long-term or routine community water supply application where iodine-containing species may remain in the drinking water.

3. MICROBIOLOGICAL WATER PURIFIER TEST PROCEDURES

3.1 Purpose

These tests are performed on ceramic filtration candles or units, halogenated resins and units and ultraviolet (UV) units in order to substantiate their microbiological removal capabilities over the effective use life of the purifier as defined in Table 1 and, where a pesticidal chemical is used, to determine that said chemical is not present in the effluent at excessive levels (see Section 3.5.3.4, Appendix N).

3.2 Apparatus

Three production units of a type are to be tested, simultaneously, if feasible; otherwise, in a manner as similar to that as possible.

Design of the testing rig must parallel and simulate projected field use conditions. For plumbed-in units a guide for design of the test rig may be taken from "Figure 1: Test Apparatus-Schematic" (p. A-2 of Standard Number 53 "Drinking Water Treatment Units -- Health Effects," National Sanitation Foundation). Otherwise, the test rig must be designed to simulate field use conditions (worst case) for the unit to be tested.

3.3 Test Waters -- Non-Microbiological Parameters

In addition to the microbiological influent challenges, the various test waters will be constituted with chemical and physical characteristics as follows:

3.3.1 Test Water #1 (General Test Water)

This water is intended for the normal non-stressed (non-challenge) phase of testing for all units and shall have specific characteristics which may easily be obtained by the adjustment of many public system tap waters, as follows:

- a. It shall be free of any chlorine or other disinfectant residual;
- b. pH -- 6.5 - 8.5;
- c. Total Organic Carbon (TOC) 0.1 - 5.0 mg/L;
- d. Turbidity 0.1 - 5 NTU;

- e. Temperature 20 C ± 5 C; and
- f. Total Dissolved Solids (TDS) 50 - 500 mg/L.

3.3.2 Test Water #2 (Challenge Test Water/Halogen Disinfection)

This water is intended for the stressed challenge phase of testing where units involve halogen disinfectants (halogen resins or other units) and shall have the following specific characteristics:

- a. Free of chlorine or other disinfectant residual;
- b. (1) pH 9.0 ± .2, and
(2) for iodine-based units a pH of 5.0 ± .2 (current information indicates that the low pH will be the most severe test for virus reduction by iodine disinfection);
- c. Total Organic Carbon (TOC) not less than 10 mg/L;
- d. Turbidity not less than 30 NTU;
- e. Temperature 4 C ± 1 C; and
- f. Total Dissolved Solids (TDS) 1,500 mg/L ± 150 mg/L.

3.3.3 Test Water #3 (Challenge Test Water/Ceramic Candle or Units With or Without Silver Impregnation)

This water is intended for the stressed challenge phase of testing for the indicated units but not for such units when impregnated with a halogen disinfectant (for the latter, use Test Water #2). It shall have the following specific characteristics:

- a. It shall be free of any chlorine or other disinfectant residual;
- b. pH 9.0 ± .2;
- c. Total Organic Carbon (TOC) -- not less than 10 mg/L;
- d. Turbidity -- not less than 30 NTU;
- e. Temperature 4 C ± 1 C; and
- f. Total Dissolved Solids (TDS) -- 1,500 mg/L ± 150 mg/L.

3.3.4 Test Water #4 (Challenge Test Water for Ultraviolet Units)

This water is intended for the stressed phase of testing for UV units and shall have the following specific characteristics:

- a. Free of chlorine or other disinfectant residual;
- b. pH 6.5 - 8.5;
- c. Total Organic Carbon (TOC) -- not less than 10 mg/L;
- d. Turbidity -- not less than 30 NTU;
- e. Temperature 4 C ~ 1 C;
- f. Total Dissolved Solids (TDS) -- 1,500 mg/l ~ 150 mg/L;
- g. Color U.V. absorption (absorption at 254 nm) -- Sufficient para-hydroxybenzoic acid (PHBH) to be just below the trigger point of the warning alarm on the U.V. unit. (Note that Section 3.5.1.1 provides an alternative of adjusting the U.V. lamp electronically, especially when the U.V. lamp is preceded by activated carbon treatment.)

3.3.5 Test Water #5 (Leaching Test Water for Units Containing Silver)

This water is intended for stressed leaching tests of units containing silver to assure that excess levels of silver will not be leached into the drinking water. It shall have the following specific characteristics:

- a. Free of chlorine or other disinfectant residual;
- b. pH -- 5.0 ~ 0.2;
- c. Total Organic Carbon (TOC) -- approximately 1.0 mg/L;
- d. Turbidity -- 0.1 - 5 NTU;
- e. Temperature -- 20 C ~ 5 C; and
- f. Total Dissolved Solids (TDS) -- 25 - 100 mg/L.

3.3.6 Recommended Materials for Adjusting Test Water Characteristics

- a. pH: inorganic acids or bases (i.e., HCl, NaOH);
- b. Total Organic Carbon (TOC): humic acids;
- c. Turbidity: A.C. Fine Test Dust (Park No. 1543094)

from: A.C. Spark Plug Division
General Motors Corporation
1300 North Dort Highway
Flint, Michigan 48556;

- d. Total Dissolved Solids (TDS): sea salts, Sigma Chemical Co., S9883 (St. Louis, MO) or another equivalent source of TDS;

- e. Color U.V. Absorption: p-hydroxybenzoic acid (grade: general purpose reagent).

3.4 Analytical Methods

3.4.1 Microbiological Methods

Methods in this section are considered "state-of-the-art" at the time of its preparation and subsequent improvements should be expected. Methods used for microbiological analyses should be compatible with and equal to or better than those given below.

3.4.1.1 Bacterial Tests

- a. Chosen Organism: Klebsiella terrigena (ATCC-33257).
- b. Method of Production: Test organism will be prepared by overnight growth in nutrient broth or equivalent to obtain the organism in the stationary growth phase (Reference: Asburg, E.D., Methods of Testing Sanitizers and Bacteriostatic Substances In: Disinfection, Sterilization and Preservation, Seymour S. Block, ed., pp. 964-980, 1983). The organism will be collected by centrifugation and washed three times in phosphate buffered saline before use. Alternatively, the organisms may be grown overnight on nutrient agar slants or equivalent and washed from the slants with phosphate buffered saline. The suspensions should be filtered through sterile Whatman Number 2 filter paper (or equivalent) to remove any bacterial clumps. New batches of organisms must be prepared daily for use in challenge testing.
- c. State of Organism: Organisms in the stationary growth phase and suspended in phosphate buffered saline will be used.
- d. Assay Techniques: Assay may be by the spread plate, pour plate or membrane filter technique on nutrient agar, M.F.C. or m-Endo medium (Standard Methods for the Examination of Water and Wastewater, 16th edition, 1985, APHA). Each sample dilution will be assayed in triplicate.

3.4.1.2 Virus Tests

- a. Chosen Organisms: Poliovirus type 1 (LSc) (ATCC-VR-59), and Rotavirus Strain SA-11 (ATCC-VR-899) or WA (ATCC-VR-2018).
- b. Method of Production: All stocks should be grown by a method described by Smith and Gerba (in Methods in Environmental Virology, pp. 15-47, 1982) and purified by the procedure of Sharp, et al. (Appl. Microbiol., 29:94-101, 1975), or similar procedure (Berman and Hoff, Appl. Environ. Microbiol., 48:317-323, 1984), as these methods will produce largely monodispersed virion particles.

- c. **State of the Organism:** Preparation procedure will largely produce monodispersed particles.
- d. **Assay Techniques:** Poliovirus type 1 may be grown in the BGM, MA-104 or other cell line which will support the growth of this virus. The rotaviruses are best grown in the MA-104 cell line. Since both viruses can be assayed on the MA-104 cell line, a challenge test may consist of equal amounts of both viruses as a mixture (i.e., the mixture must contain at least 1.0×10^7 /mL of each virus). Assays may be as plaque forming units (PFU) or as immunofluorescence foci (IF) (Smith and Gerba, In: Methods in Environmental Virology, pp. 15-47, 1982). Each dilution will be assayed in triplicate.

3.4.1.3 Cyst Tests

a. Chosen Organism

1. Giardia lamblia or the related organism, Giardia muris, may be used as the challenge cyst.
2. Where filtration is involved, tests with 4-6 micron spheres or particles have been found to be satisfactory and may be used as a substitute for tests of occlusion using live organisms (see Table 1). Spheres or particles may only be used to evaluate filtration efficacy. Disinfection efficacy can only be evaluated with the use of viable Giardia cysts.

- b. **Method of Production:** Giardia muris may be produced in laboratory mice and Giardia lamblia may be produced in Mongolian gerbils; inactivation results based on excystation measurements correlate well with animal infectivity results.
- c. **State of the Organism:** Organisms may be separated from fecal material by the procedure described by Sauch (Appl. Environ. Microbiol., 48:454-455, 1984) or by the procedure described by Bingham, et al. (Exp. Parasitol., 47:284-281, 1979).
- d. **Assay Techniques:** Cysts are first reconcentrated (500 ml., minimum sample size) according to the method of Rice, Hoff and Schaefer (Appl. Environ. Microbiol., 43:250-251, 1982). The excystation method described by Schaefer, et al. (Trans., Royal Soc. of Trop. Med. & Hyg. 78:795-800, 1984) shall be used to evaluate Giardia muris cyst viability. For Giardia lamblia cysts, the excystation method described by Bingham and Meyer (Nature, 277:301-302, 1979) or Rice and Schaefer (J. Clin. Microbiol., 14:709-710, 1981) shall be used. Cyst viability may also be determined by an assay method involving the counting of trophozoites as well as intact cysts (Bingham, et al., Exp. Parasitol., 47:284-291, 1979).

3.4.2 Chemical and Physical Methods

All physical and chemical analyses shall be conducted in accordance with procedures in Standard Methods for the Examination of Water and Wastewater, 16th Edition, American Public Health Association, or equivalent.

3.5 Test Procedures

3.5.1 Procedure - Plumbed-in Units

- a. 1. Install three production units of a type as shown in Figure 1 and condition each unit prior to the start of the test in accordance with the manufacturer's instructions with the test water without the addition of the test contaminant. Measure the flow rate through each unit. The unit shall be tested at the maximum system pressure of 60 psig static and flow rate will not be artificially controlled.
2. Test waters shall have the defined characteristics continuously except for test waters 2, 3 and 4 with respect to turbidity. The background non-sampling turbidity level will be maintained at 0.1-5 NTU but the turbidity shall be increased to the challenge level of not less than 30 NTU in the following manner:
 - In the "on" period(s) prior to the sampling "on" period.
 - In the sampling "on" period when the sample actually will be taken. (Note: at least 10 unit void volumes of the 30 NTU water shall pass through the unit prior to actual sampling so as to provide adequate seasoning and uniformity before sample collection.)
- b. 1. Use appropriate techniques of dilution and insure continual mixing to prepare a challenge solution containing the bacterial contaminant. Then spike test water continuously with the influent concentration specified in Table 1.
2. Use appropriate techniques to prepare concentrated virus and Giardia suspensions. Feed these suspensions into the influent stream so as to achieve the influent concentrations specified in Table 1 in the following manner:
 - In the "on" period(s) prior to the sampling "on" period.
 - In the sampling "on" period when the sample actually will be taken. (Note: at least 10 unit void volumes of seeded water shall pass through the unit prior to sampling so as to provide adequate seasoning and uniformity before sample collection.)

- c. Purge the system of the uncontaminated water with a sufficient flow of contaminated test water. Start an operating cycle of 10 percent on, 90 percent off with a 15 to 40 minute cycle (Example: 3 minutes on, 27 minutes off) with the contaminated test water. This cycle shall be continued for not more than 16 hours per day (minimum daily rest period of 8 hours). The total program shall extend to 100% of estimated volume capacity for halogenated resins or units and for 10-1/2 days for ceramic candles or units and U.V. units.
- d. Sampling: Samples of influent and effluent water at the specified sampling points shall be collected as shown below for the various units; these are minimum sampling plans which may be increased in number by the investigator. All samples shall be collected in duplicate from the flowing water during the sampling "on" portion of the cycle and they shall be one "unit void volume" in quantity (or of appropriate quantity for analysis) and represent worst case challenge conditions. Effluent samples shall usually be collected near the middle of the sampling "on" period (or the whole volume during one "on" period) except for samples following the specified "stagnation" periods, for which sampling shall be conducted on the first water volume out of the unit. Each sample will be taken in duplicate and shall be retained and appropriately preserved, if required, for chemical or microbiological analysis in the event verification is required. (For units where the volume of a single "on" period is insufficient for the required analysis, samples from successive "on" periods may be accumulated until a sufficient volume has been collected.)

1(a). Sampling Plan: Halogenated Resins or Units (Non-iodine Based)

Test Point (% of Estimated Capacity)	Test Water	Tests		
		Influent Background	Active Agent/ Residual	Microbiological
Start	General	X	X	X
25%			X	X
50%			X	X
After 48 hours stagnation			X	X
60%	Chal-		X	X
75%	lenge		X	X
* After 48 hours stagnation	pH - 9.0 ± 0.2		X	X
100%			X	X

1(b). Sampling Plan: Iodinated Resins or Units

<u>Test Point</u> (% of Estimated Capacity)	<u>Test</u> <u>Water</u>	<u>Tests</u>		
		<u>Influent</u> <u>Background</u>	<u>Active</u> <u>Agent/</u> <u>Residual</u>	<u>Microbiological</u>
Start	General	X	X	X
25%			X	X
50%			X	X
After 48 hours stagnation			X	X
60%	Chal-		X	X
75%	lence		X	X
After 48 hours stagnation	pH - 9.0 ~ 0.2		X	X
90%	Chal-		X	X
100%	lence		X	X
After 48 hours stagnation	pH - 5.0 ~ 0.2		X	X

2. Sampling Plan: Ceramic Candles or Units and U.V. Units

<u>Test Point</u>	<u>Test</u> <u>Water</u>	<u>Tests</u>	
		<u>Influent</u> <u>Background</u>	<u>Microbiological</u>
Start	General	X	X
Day 3 (middle)			X
Day 6 (middle)			X
After 48 hours stagnation			X
Day 7 (middle)			X
Day 8 (near end)	Chal-		X
After 48 hours stagnation	lence		X
Day 10-1/2			X

(Note: All days are "running days" and exclude stagnation periods. When the units contain silver, a leaching test shall be conducted as shown in Section 3.5.1.e and silver residual will be measured at each microbiological sampling point.)

- e. **Leaching Tests for Silverized Units:** Where the unit contains silver, additional tests utilizing Test Water #5 will be conducted as follows:

<u>Test Point</u>	<u>Tests</u>	
	<u>Influent Background</u>	<u>Silver/Residual</u>
Start	X	X
Day 2		X
After 48 hours stagnation		X

f. **Alternate Sampling Plans:**

1. Since some laboratories may find it inconvenient to test some units on a 16 hour on/8 hour off cycle, two alternates are recognized:

- Go to a shorter operational day but lengthen the days of test proportionally
- Use up to 20 percent "on"/80 percent "off" for a proportionally shorter operational day

2. Sampling points must be appropriately adjusted in any alternate sampling plan.

- g. **Application of Test Waters:** The application of test waters is designed to provide information on performance under both normal and stressed conditions; it should be the same or equivalent to the following:

1. a. **Halogenated Resins or Units (Non-iodine based) --**

First 50% of test period:	Test Water 1 (General)
Last 50% of test period:	Test Water 2 (Challenge) (pH - 9.0 ± 0.2)

- b. **Iodinated Resins or Units --**

First 50% of test period:	Test Water 1 (General)
Next 25% of test period:	Test Water 2 (Challenge) (pH - 9.0 ± 0.2)
Last 25% of test period:	Test Water 2 (Challenge) (but with pH - 5.0 ± 0.2)

2. **Ceramic Candles or Units --**

First 6 days of testing:	Test Water 1 (General)
--------------------------	------------------------

Last 4-1/2 days of testing: Test Water 3 (Challenge)

3. Ultraviolet (U.V.) Units --

First 6 days of testing: Test Water 1 (General)

Last 4-1/2 days of testing: Test Water 4 (Challenge)

h. Analyses and monitoring:

1. Microbiological sampling and analysis shall be conducted of the specified influent and effluent sampling points during each indicated sampling period.
 2. Test Water Monitoring: The specified parameters of the various test waters (see Section 3.3) will be measured and recorded at each microbiological sampling point; the specified parameters will be measured at least once on non-sampling days when the units are being operated.
 3. Background chemical analyses of influent water shall be conducted at least once at the start of each test period to determine the concentration of the U.S. EPA primary inorganic contaminants, secondary contaminants and routine water parameters, not otherwise covered in the described test waters.
 4. In addition, quality assurance testing shall be conducted for the seed bacteria under environmental conditions on the first and last days of testing to make sure that there is no significant change over the test day. Populations will be measured (for example, as dispersed in the supply tank) at the beginning and end of the test day to detect possible incidental effects such as proliferation, die-off, adsorption to surfaces, etc. Relatively stable bacterial seed populations are essential to an acceptable test program.
 5. When a unit contains a halogen or silver, the active agent residual will be measured in the effluent at each microbiological test (sampling) point.
 6. Silver will additionally be measured three times in the effluent as specified in Section 3.5.1.e.
- i. Neutralization of Disinfection Activity: Immediately after collection, each test sample must be treated to neutralize residual disinfectant. For halogen- and silver-based disinfectants this may be done by addition of thioglycollate-thiosulfate neutralizer solution (Chambers, et al., J. Amer. Water Works Assoc., 54:208-216, 1962). This solution should be prepared daily. All results are invalid unless samples are neutralized immediately upon collection.
- j. Special Provisions for Ceramic Candles or Units:

1. Provisions for slow flow: Ceramic units may be subject to clogging and greatly reduced flow over the test period. An attempt should be made to maintain manufacturer rated or claimed flow rates, but even at reduced flows the sampling program set forth in Section 3.5.1.d.2 shall be maintained.
 2. Cleaning of ceramic units: Units should be cleaned according to manufacturer's directions. Two cleanings should occur during the period of test (in order to prove the unit's durability through the cleaning procedure). However, near the time of microbiological sampling, the units should not be cleaned until after the sampling. Further, no anti-microbial chemical (for cleaning or sanitizing) may be applied to the units during the test period unless the manufacturer specifies the same as part of routine maintenance.
- k. Halogenated units or U.V. units with mechanical filtration processes separate from the microbiological disinfection components shall have the mechanical filtration components replaced or serviced when significant flow reduction (clogging) occurs in accordance with the manufacturer's instructions in order to maintain the test flow rate. Units with non-removable mechanical filtration components will be run until flow is below that considered acceptable for consumer convenience. (If premature clogging presents a problem, some specialized units may require a customized test plan.)
1. Special Provisions for Ultraviolet (U.V.) Units:
 1. The units will be adequately challenged by the prescribed test waters; consequently they will be operated at normal intensity. However, where the U.V. treatment component is preceded by activated carbon treatment, the output of the U.V. lamp shall be adjusted electronically, such as by reducing the current to the lamp or other appropriate means, to be just above the alarm point. This option shall be available for use under other U.V. configurations, at the choice of the persons responsible for testing, as an alternative to the use of the U.V. absorbent, p-hydroxybenzoic acid.
 2. Fail/safe: Units will provide and will be tested for fail/safe warnings in the event of water quality changes or equipment failures which may interfere with its microbiological purification function.
 3. Cleaning: Manufacturer's guidance with respect to cleaning will be followed.

3.5.2 Procedure: Non-Plumbed Units

- a. General: The basic procedures given in Section 3.5.1 shall be used with necessary adaptations to allow for the specific design of the

unit. In any event, the testing procedures shall provide a test challenge equivalent to those for plumbed-in units.

- b. Test conditions and apparatus should be adapted to reflect proposed or actual use conditions in consultation with the manufacturer, including flow rate and number of people to be served per day. In some cases variable flow or other non-standard conditions may be necessary to reflect a worst-case test.

3.5.3 Acceptance and Records

3.5.3.1

To qualify as a microbiological water purifier, all three production units of a type must continuously meet or exceed the reduction requirements of Table 1, within allowable measurement tolerances for not more than ten percent of influent/effluent sample pairs, defined as follows:

Virus:	one order of magnitude
Bacteria:	one order of magnitude
Cysts:	one/half order of magnitude

The geometric mean of all microbiological reductions must meet or exceed the requirements of Table 1. An example is given as follows:

- Unit: iodinated resin.
- Number of sample pairs over the completed test program:
10 per unit -- 3 units = 30.
- Number of allowable sample pairs where log reduction is insufficient: 10% of 30 = 3 sample pairs.
- Allowable minimum log reductions in these 3 pairs:
 - Bacteria - 5 log
 - Virus - 3 log
 - Cyst - 2-1/2 log
- Conclusion: If the geometric mean of all reductions meets or exceeds the requirements of Table 1, the indicated insufficient sample pairs will be allowed.

3.5.3.2 Records

All pertinent procedures and data shall be recorded in a standard format and retained for possible review until the report of results has been completely accepted by review authorities, in no case for less than a year.

3.5.3.3 Scaling Up or Down

Where a manufacturer has several similar units using the same basic technology and parallel construction and operation, it may sometimes be appropriate to allow the test of one unit to be considered representative of others. Where any serious doubt exists, all units of various sizes may require testing. A "rule of three" is suggested as a matter of judgment. Scaling up to three times larger or one-third, based on the size of either the test unit or of its operative element, may be allowed. However, for UV units, any size scale-up must be accompanied by a parallel increase in radiation dose.

3.5.3.4

Where silver or some other chemical is used in the unit, concentrations in the effluent water must meet any National Primary Drinking Water Maximum Contaminant Level (MCL), additional Federal guidelines, or otherwise must not constitute a threat to health where no MCL exists.

APPENDIX N-1

SUMMARY FOR BASIS OF STANDARDS AND TEST WATER PARAMETERS

A. Microbiological Reduction Requirements

1. Bacteria

Current standards for the microbiological safety of drinking water are based on the presence of coliform bacteria of which Klebsiella is a member. Members of the genus Klebsiella are also potential pathogens of man (Vlassof, 1977). Klebsiella terrigena is designated as the test organism since it is commonly found in surface waters (Izard, et al., 1981).

Experience with the use of coliform bacteria to estimate the presence of enteric bacterial pathogens in drinking water as performed over the last 75 years indicates a high degree of reliability. Required testing of more than one bacterial pathogen appears unjustified since viral and Giardia testing will be required. Enteric viruses and Giardia are known to be more resistant to common disinfectants than enteric bacterial pathogens and viruses are more resistant to removal by treatments such as filtration. Thus, any treatment which would give a good removal of both virus and Giardia pathogens would most likely reduce enteric bacteria below levels considered infectious (Jarroll, et al., 1981; Liu, et al., 1971).

The concentration of coliform bacteria in raw sewage is approximately 10^9 /100 ml. Concentrations in polluted stream waters have been found to exceed 10^5 per 100 ml (Culp, et al., 1978, Table 10).

Based on the over 10^5 /100 ml concentrations observed in highly polluted stream water and a target effluent concentration of less than 1/100 ml, a 6 log reduction is recommended.

2. Virus

In the United States concentrations of enteroviruses are estimated to range from 10^3 - 10^4 /liter in raw sewage (Farrah and Schaub, 1971). Based on this observation it is estimated that natural waters contaminated with raw sewage may contain from 10^1 to 10^2 enteric viruses per liter.

There are currently no standards for viruses in drinking water in the United States. However, EPA has proposed a non-enforceable health-based recommended maximum contaminant level (RMCL) of zero for viruses (EPA, 1985). Several individuals and organizations have developed guidelines for the presence of viruses in drinking water and various experts have proposed standards (WHO, 1979, 1984; Berg, 1971; Melnick, 1976). It has generally been felt that drinking

water should be free of infectious virus since even one virus is potentially infectious and suggested standards are largely based on technological limits of our detection methodology. Guidelines suggested by the World Health Organization (1984) and others recommend that volumes to be tested be in the order of 100-1,000 liters and that viruses be absent in these volumes.

Assuming a target effluent level of less than one virus in 100 liters of water and a concentration of 10^4 enteric viruses in 100 liters of sewage-contaminated waters, the water purifier units should achieve at least 4 logs of virus removal.

The relative resistance of enteric viruses to different disinfectants varies greatly among the enteric viruses and even among members of the same group (i.e., enteroviruses). For example, while f2 coliphage is one of the most resistant viruses to inactivation by chlorine it is one of the most susceptible to inactivation by ozone (Harakeh and Butler, 1984). Ionic conditions and pH can also affect the relative resistance of different viruses to a disinfectant (Engelbrecht, et al., 1980). On this basis it is felt that more than one enteric virus should be tested to ensure the efficacy of any disinfection system. Poliovirus type 1 (Strain LSc) was chosen as one of the test viruses because it has been extensively used in disinfection and environmental studies as representative of the enterovirus family. It is recognized that it is not the most resistant virus to inactivation by chlorine, but is still resistant enough to serve as a useful indicator. Rotavirus is selected as the second test enteric virus since it represents another group of enteric viruses in nucleic acid composition and size. It is also a major cause of viral gastroenteritis and has been documented as a cause of water borne gastroenteritis (Gerba, et al., 1985). The human rotavirus or the similar Simian rotavirus may be used in the test procedure. A net 4-log reduction for a joint challenge of 1×10^7 /L each for poliovirus and rotavirus is recommended.

3. Cysts (Protozoan)

Over the past several years, giardiasis has consistently been one of the most frequently reported waterborne diseases transmitted by drinking water in the United States (Craun, 1984). EPA has proposed a RMCL of zero for Giardia (EPA, 1985). Its occurrence has generally been associated with treatment deficiencies including either inadequate or no filtration. Giardiasis has not been known to occur from drinking water produced by well-operated filtration treatment plants. De Walle, et al. (1984), in a study of filtration treatment plant efficiencies, cited percent removals for Giardia in pilot plant tests as follows:

- Rapid filtration with coagulation-sedimentation: 96.6-99.9%;
- Direct filtration with coagulation: 95.9-99.9%.

From this research and from the lack of Giardia cases in systems where adequate filtration exists, a 3-log (99.9%) reduction requirement is considered to be conservative and to provide a comparable level of protection for water purifiers to a well-operated filtration treatment plant.

Data on environmental levels for cysts in natural waters is limited because of the difficulties of sampling and analysis. Unpublished data indicate very low levels from less than 1/L to less than 10/L. Here a 3-log reduction would provide an effluent of less than 1/100 L, comparable to the recommended virus reduction requirements.

Either Giardia lamblia or the related organism, Giardia muris, which is reported to be a satisfactory test organism (Hoff, et al., 1985), may be used as the challenge organism. Tests will be conducted with a challenge of 10^6 organisms per liter for a 3-log reduction.

Where the treatment unit or component for cysts is based on the principle of occlusion filtration alone, testing for a 3-log reduction of 4-6 micron particles or spheres (National Sanitation Foundation Standard 53, as an example) is acceptable. Difficulties in the cyst production and measurement technologies by lesser-equipped laboratories may require the use of such alternative tests where applicable.

B. Microbiological Purifier Test Procedures

1. Test Waters

- a. The general test water (test water #1) is designed for the normal, non-stressed phase of testing with characteristics that may easily be obtained by the adjustment of many public system tap waters.
- b. Test water #2 is intended for the stressed phase of testing where units involve halogen disinfectants.
 1. Since the disinfection activity of some halogens falls with a rising pH, it is important to stress test at an elevated pH. The recommended level of 9.0 ± 0.2 , while exceeding the recommended secondary level (Environmental Protection Agency, 1984) is still within a range seen in some natural waters (Environmental Protection Agency, 1976). However, for iodine-based units, a second stressful condition is provided -- a pH of 5.0 ± 0.2 since current information indicates that the disinfection activity of iodine falls with a low pH (National Research Council, 1980). While beneath the recommended secondary level (Environmental Protection Agency, 1984) a pH of 5.0

is not unusual in natural waters (Environmental Protection Agency, 1976).

2. Organic matter as total organic carbon (TOC) is known to interfere with halogen disinfection. While this TOC is higher than levels in many natural waters, the designated concentration of 10 mg/L is cited as typical in stream waters (Culp/Wesner/Culp, 1978).
 3. High concentrations of turbidity can shield microorganisms and interfere with disinfection. While the recommended level of not less than 30 NTU is in the range of turbidities seen in secondary wastewater effluents, this level is also found in many surface waters, especially during periods of heavy rainfall and snow melt (Culp/Wesner/Culp, 1978).
 4. Studies with Giardia cysts have shown decreasing halogen disinfection activity with lower temperatures (Jarroll, et al., 1980); 4 C, a common low temperature in many natural waters, is recommended for the stress test.
 5. The amount of dissolved solids (TDS) may impact the disinfection effectiveness of units that rely on displaceable or exchange elements by displacement of halogens or resins, or it may interfere with adsorptive processes. While TDS levels of 10,000 mg/L are considered unusable for drinking, many supplies with over 2,000 mg/L are used for potable purposes (Environmental Protection Agency, 1984). The recommended level of 1,500 mg/L represents a realistic stress challenge.
- c. Test water #3 is intended for the stressed phase of testing of ceramic filtration candles or units with or without silver impregnation.
1. Since viruses are typically eluted from adsorbing media at high pHs (Environmental Protection Agency, 1978) it may be concluded that a high pH will provide the most stressful testing for a ceramic-type unit; consequently, the high natural water pH of 9.0 is recommended.
 2. Expert opinion also holds that organic material will interfere with adsorption of viruses. Thus, a high total organic carbon level of not less than 10 mg/L is recommended.
 3. Turbidity may enhance the entrapment and removal of microorganisms but it also may stimulate "short-circuiting" through some units. A turbidity level of 30 NTU will provide stress at time of sampling but the

non-sampling level of 0.1-5 NTU will allow routine operation of units.

4. Expert opinion holds that low water temperatures and high TDS would most likely interfere with virus reduction by adsorption; consequently, a 4 C temperature and 1,500 mg/L TDS are recommended.
- d. Test water #4 is intended for the stressed phase of testing for ultraviolet (UV) units.
1. In general, high TOC, turbidity and TDS and low temperature are considered most stressful for UV, and the indicated challenge levels are the same as for test water #2.
 2. The pH is not critical and may range from 6.5 to 8.5.
 3. In order to test the UV units at their most vulnerable stage of operation, a color challenge (light absorption at 254 nm) is to be maintained at a level where UV light intensity is just above the unit's low intensity warning alarm point. However, an alternate to the absorption challenge is provided through adjusting the light intensity output of the UV lamp electronically by reducing current to the lamp, or other appropriate means, to be just above the alarm point; this approach would be particularly necessary where the UV lamp is preceded by activated carbon treatment.
- e. Test water #5 is intended for the stressed leaching tests of units containing silver. Low pH, TOC, turbidity, and TDS and higher temperature are felt to be the characteristics associated with increased leachability. The recommended pH of 5.0 ± .2, while being beneath the recommended secondary range of 6.5-8.5 (Environmental Protection Agency, 1984) is still found in some natural waters.

2. Test Procedures

The plan for testing and sampling is designed to reveal unit performance under both "normal" and "stressed" operating conditions. The stressed phase would utilize a set of water quality and operations conditions to give the units a realistic worst case challenge. Testing plans for a specific model might involve modifications to the recommended plan; more samples could be taken and analyzed; more units could be studied. The principle of demonstrating adequate performance even under realistic worst case conditions should be maintained and the final selected test procedures should be agreed as between investigators and reviewers or regulators.

While some aspects of the testing procedures have been utilized in actual experiments, the proposed protocol has not been verified or utilized for the various units that may be considered. Consequently, investigators and users of this protocol may find reasons to alter some aspects through their practical experience; needed changes should be discussed and cleared with involved reviewers/regulators.

REFERENCES:

Berg, G. Integrated approach to the problem of viruses in water. J. ASCE, Sanit. Eng. Div. 97:867-882, 1971.

Culp/Wesner/Culp. Guidance for planning the location of water supply intakes downstream from municipal wastewater treatment facilities. EPA Report, Office of Drinking Water. Washington, DC, 1978.

Craun, G. F. 1984. Waterborne outbreaks of giardiasis: Current status. In: Giardia and giardiasis. D. L. Erlandsen and E. A. Meyer Eds., Plenum Press, New York, pp. 243-261, 1984.

DeWalle, F. B.; J. Engeset; Lawrence, W. Removal of Giardia lamblia cyst by drinking water treatment plants. Report No. EPA-600/52-84-069, Office of Research and Development, Cincinnati, OH, 1984.

Engelbrecht, R. S., et al. Comparative inactivation of viruses by chlorine. Appl. Environ. Microbiol. 40:249-256, 1980.

Environmental Protection Agency. Quality criteria for water. Washington, DC, 1976.

Environmental Protection Agency. National secondary drinking water regulations. EPA-570/9-76-000, Washington, DC, 1984.

Environmental Protection Agency. National primary drinking water regulations; synthetic organic chemicals, inorganic chemicals and microorganisms; Proposed rule. Federal Register, Nov. 13, 1985.

Farrar, S. R., and S. A. Schaub. Viruses in wastewater sludges. In: Viral Pollution of the Environment, G. Berg, Ed. CRC Press, Boca Raton, Florida. pp. 161-163, 1983.

Gerba, C. P.; Rose, J. B.; Singh, S. N. Waterborne gastroenteritis and viral hepatitis. CRC Critical Rev. Environ. Contr. 15:213-236, 1985.

Harakeh, M.; Butler, M. Inactivation of human rotavirus, SA-11 and other enteric viruses in effluent by disinfectants. J. Hyg. Camb. 93:157-163, 1984.

Hoff, J. C.; Rice, E. W.; Schaefer, F. W. Comparison of animal infectivity and excystation as measures of Giardia muris cyst inactivation by chlorine. Appl. Environ. Microbiol. 50:1115-1117, 1985.

Izard, D.; Farragut, C.; Gavini, F.; Kersters, K.; DeLey, J.; Leclerc, H. Klebsiella terrigena, a new species from water and soil. Intl. J. Systematic Bacteriol. 31:116-127, 1981.

Jakubowski, W. Detection of Giardia cysts in drinking water. In: Giardia and Giardiasis, Erlandsen, S. L.; Meyer, E. A. Eds., Plenum Press, NY. pp. 263-286, 1984.

Jarroll, E. L.; Bingham, A. K.; Meyer, E. A. Giardia cyst destruction: Effectiveness of six small-quantity water disinfection methods. Am. J. Trop. Med. 29:8-11, 1980

Jarroll, E. L.; Bingham, A. K.; Meyer, E. A. Effect of chlorine on Giardia cyst viability. Appl. Environ. Microbiol. 43:483-487, 1981.

Liu, O. C., et al. Relative resistance of 20 human enteric viruses to free chlorine in Potomac River water. Proceedings of 13th Water Quality Conference Snøeyink, V.; Griffin, V. Eds., pp. 171-195, 1971.

Melnick, J. L. Viruses in water. In: Viruses in Water Berg, G.; Bodily, H. L.; Lennette, E. H.; Melnick, J. L.; Metclaf T. G., Eds. Amer. Public Hlth. Assoc., Washington, DE, pp. 3-11, 1976.

National Research Council. The disinfection of drinking water, In: Drinking Water and Health, Volume 2. Washington, DC, pp. 5-137, 1980.

National Sanitation Foundation. Drinking water treatment units: Health effects. Standard 53. Ann Arbor, MI, 1982.

Vlassoff, L. T. Klebsiella. In: Bacterial Indicators/Health Hazards Associated with Water Hoadley, A. W.; Dutka, B. J., Eds. American Society for Testing and Materials, Philadelphia, PA. pp. 275-288, 1977.

World Health Organization. Human Viruses in Water, Technical Support Series 639, World Health Organization, Geneva, 1979.

World Health Organization. Guidelines for Drinking Water Quality. Volume 1. Recommendations. World Health Organization, Geneva, 1984.

APPENDIX N-2

LIST OF PARTICIPANTS: TASK FORCE ON GUIDE STANDARD AND PROTOCOL FOR
TESTING MICROBIOLOGICAL WATER PURIFIERS

Stephen A. Schaub, Chairman -- U.S. Army Medical Bioengineering Research and Development Laboratory (USAMBRDL), Fort Detrick, Maryland 21701, FTS: 8/935-7207 -- Comm: 301/663-7207.

Frank A. Bell, Jr., Secretary -- Criteria and Standards Division, Office of Drinking Water (WH-550), Environmental Protection Agency, Washington, D.C. 20460, Phone: 202/382-3037.

Paul Berger, Ph.D. -- Criteria and Standards Division, Office of Drinking Water (WH-550), Environmental Protection Agency, Washington, D.C. 20460, Phone: 202/382-3039.

Art Castillo -- Disinfectants Branch, Office of Pesticide Programs (TS-767C0), Environmental Protection Agency, Washington, D.C. 20460, Phone: 703/557-3695.

Ruth Douglas -- Disinfectants Branch, Office of Pesticide Programs (TS-767C), Environmental Protection Agency, Washington, D.C. 20460, Phone: 703/557-3675.

Al Dufour -- Microbiology Branch, Health Effects Research Laboratory, Environmental Protection Agency, 26 W. St. Clair Street, Cincinnati, Ohio 45268, Phone: FTS: 8/684-7870 -- Comm: 513/569-7870.

Ed Geldreich -- Chief, Microbiological Treatment Branch, Water Engineering Research Laboratory, Environmental Protection Agency, 26 W. St. Clair Street, Cincinnati, Ohio 45268, Phone: FTS: 8/684-7232 -- Comm: 513/569-7232.

Charles Gerba -- Associate Professor, Department of Microbiology and Immunology, University of Arizona, Tucson, Arizona 85721, Phone: 602/621-6906.

John Hoff -- Microbiological Treatment Branch, Water Engineering Research Laboratory, Environmental Protection Agency, 26 W. St. Clair Street, Cincinnati, Ohio 45268, Phone: FTS: 8/684-7331 -- Comm: 513/569-7331.

Art Kaplan -- Office of Research and Development (RD-681) Environmental Protection Agency, Washington, D.C. 20460, Phone: 202/382-2583.

Bala Krishnan -- Office of Research and Development (RD-681) Environmental Protection Agency, Washington D.C. 20460, Phone: 202/382-2583.

John Lee -- Disinfectants Branch, Office of Pesticide Programs (TS-767C)

Environmental Protection Agency, Washington, D.C. 20460, Phone:
703/557-3663.

Dorothy Portner -- Disinfectants Branch, Office of Pesticide Programs
(TS-767-C), Environmental Protection Agency, Washington, D.C. 20460,
Phone: 703/557-0484.

Don Reasoner -- Microbiological Treatment Branch, Water Engineering Research
Laboratory, Environmental Protection Agency, 26 W. St. Clair Street,
Cincinnati, Ohio 45268, Phone: 312/654-4000.

P. Reguanthan (Regu) -- Everpure, Inc., 660 N. Blackhawk Drive, Westmont,
Illinois 60559, Phone: 312/654-4000.

David Stangel -- Policy and Analysis Branch, Office of Compliance Monitoring,
Environmental Protection Agency, Washington, D.C., Phone: 202/382-7845.

Richard Tobin -- Monitoring and Criteria Division, Environmental Health
Center, Department of Health and Welfare of Canada, Tunney's Pasture,
Ottawa, Ontario, K1A 0L2, Canada, Phone: 613/990-8982.

APPENDIX N-3

RESPONSE BY REVIEW SUBCOMMITTEE⁽¹⁾ TO PUBLIC COMMENTS ON GUIDE STANDARD
AND PROTOCOL FOR TESTING MICROBIOLOGICAL WATER PURIFIERS

- A. Recommendation for the use of Giardia lamblia cysts as a replacement for Giardia muris cysts as the protozoan cyst test organisms.

Recommendation:

The subcommittee concurs with the recommendation and further endorses the use of Giardia lamblia as the preferred cyst test for evaluation of all treatment units and devices. Obviously the use of the protozoan organisms of actual health concern in testing is most desirable. Anyone finding the Giardia lamblia strain feasible for testing and cost-effective to work with is encouraged to use same instead of Giardia muris.

- B. Substitution of 4-6 micron bead or particle tests as an alternate option instead of the Giardia cysts for evaluating devices that rely strictly on occlusion filtration for microbiological removal: Several commenters criticized the use of beads or particles (e.g., A.C. fine dust) and recommended only use of live Giardia cysts for performance tests.

Discussion:

The subcommittee recognizes and favors the use of the natural human parasite, Giardia lamblia, but was not aware of any convincing scientific data which would disallow the optional use of testing with beads or particles for units or devices using only occlusion filtration to remove microorganisms. Previous development of the National Sanitation Standard (NSF) 53 (1982) requirement for cyst reduction (using 4-6 micron particles as cyst models) was based on engineering and scientific opinion and experimental evidence at that time. Specifically, Logsdon⁽¹⁾ used radioactive cyst models in the initial phase of a study of removal efficiencies for diatomaceous earth filters; subsequent experiments with Giardia muris cysts confirmed the efficacy of the diatomaceous earth filters. Further studies by Hendricks⁽²⁾ and DeWalle⁽³⁾ with Giardia lamblia cysts also showed comparable reduction efficiencies for diatomaceous earth filters.

1.S.A. Schaub; F.A. Bell, Jr.; P. Berger; C. Gerba; J. Hoff; P. Regunathan; and R. Tobin. [Includes additional revision pursuant to Scientific Advisory Panel review (Federal Insecticide, Fungicide, and Rodenticide Act).]

Subsequently confirmatory parallel testing results have been developed vis-a-vis 4-6 micron particles as compared to Giardia lamblia cysts. Specifically, two units listed by NSF for cyst reduction (using 4-6 micron particles)⁽⁴⁾ have also been tested and listed for 100% efficiency reduction (using Giardia lamblia cysts) by Hibler⁽⁵⁾:

1. Everpure Model QC4-SC
2. Royal Boulton Model F303.

Again we prefer the use of the human pathogen, Giardia lamblia; however, no experimental data has been provided regarding the lack of validity or of failure in previous tests utilizing beads or particles of 4-6 microns. In most cases the bacterial or viral challenges to occlusion filters ill represent a greater problem in terms of microbiological reduction requirements than will cysts. Therefore, without substantiation of deficiencies, the use of 4-6 micron beads or particles is considered to be as feasible as the use of live cysts for routine performance testing of water filtration (occlusion) devices.

Recommendation:

Recommend retaining the optional use of 4-6 micron particles or beads for cyst reduction testing in occlusion filtration devices only.

References:

- (1) Logsdon, G. S., et al. Alternative Filtration Methods for Removal of Giardia Cysts and Cyst Models, JAWWA, 73(2)111-118, 1981.
 - (2) Logsdon, G. S.; Hendricks, D. W., et al. Control of Giardia Cysts by Filtration: The Laboratory's Rose. Presented at the AWWA Water Quality Technology Conference, December, 1983.
 - (3) DeWalle, et al. Removal of Giardia lamblia Cysts by Drinking Water Treatment Plants, Grant No. R806127, Report to Drinking Water Research Division, U.S. EPA (ORD/MERL), Cincinnati, Ohio.
 - (4) National Sanitation Foundation, Listing of Drinking Water Treatment Units, Standard 53. May, 1986.
 - (5) Hibler, C. P. An Evaluation of Filters in the Removal of Giardia lamblia. Water Technology, pp. 34-36. July, 1984.
- C. Alternate assay techniques for cyst tests (Jensen): Proposed alterations in cyst tests include a different method for separating cysts from fecal material and an assay method involving the counting of trophozoites as well as intact cysts. Both alterations have been used by Bingham, et al. (Exp. Parasitol., 47:284-291, 1979).

Recommendation:

These alterations appear to be reasonable laboratory procedures, supported by a peer-reviewed article and will be included in the Report as options for possible development and use by interested laboratories.

- D. The use of pour plate techniques as an option for Klebsiella terrigena bacteria analyses.

Recommendation:

The pour plate technique adds a heat stress factor to the bacteria which constitutes a possible deficiency. However, it is a recognized standard method and probably will not adversely affect the Klebsiella terrigena. Consequently, it will be added to the Report as one of the acceptable techniques.

- E. Option of using Escherichia coli in lieu of Klebsiella terrigena for the bacterial tests.

Discussion:

Appendix N-1, Section A.1. of the Guide Standard and Protocol sets forth the basis for selection of K. terrigena as the test bacteria. The selection was made along pragmatic line emphasizing the occurrence of K. terrigena in surface waters and that it would represent the enteric bacteria. It was also pointed out that the tests with virus and Giardia were expected to be more severe than the bacterial tests. For comprehensiveness, bacterial tests were included in the protocol but were not felt to be as crucial as the virus and Giardia tests.

E. coli, or any number of other generally accepted indicator bacteria, could be used for the test program if they were shown to have good testing and survival characteristics (equivalent to K. terrigena) by the interested research laboratory.

Recommendation:

The intent of the Guide Standard and Protocol is to provide a baseline program subject to modification when properly supported by an interested laboratory. Consequently, any laboratory could propose and with proper support (demonstrating challenge and test equivalency to K. terrigena) use Escherichia coli or one of the other enteric bacteria. This idea will be included in revised working in Section 1.2.2, "General Guide."

- F. Performance requirements for Giardia cysts and virus in relation to the EPA-Recommended Maximum Contamination Levels (RMCLs) of zero.

Discussion:

The RMCLs of zero for Giardia and viruses which have been proposed by EPA are health goals. They are no enforceable standards since to assure the presence of "no organisms" would require an infinite sample. The

rationale for the recommended performance requirements for Giardia cysts and virus is set forth in Sections A.2 and A.3 of Appendix A. We feel that these requirements together with the application of realistic worst case test conditions will provide a conservative test for units resulting in treated effluent water equivalent to that of a public water supply meeting the microbiological requirements and intent of the National Primary Drinking Water Regulations.

Recommendation:

Retain recommended performance (log reduction) requirements for cyst and virus reduction.

- G. Rotavirus and its proposed assay: One commenter states that the rotavirus tests are impractical because Amirtharajah (J. AWWA, 78(3):34-49, 1976) cites "no satisfactory culture procedures available for analysis of these pathogens and, therefore, monitoring would not be feasible."

Discussion:

Section 3.4.1.2, "Virus Tests" of the Report, presents means for culturing and assaying rotaviruses. This means for doing the rotavirus tests are available and are practical for application in the laboratory. Dr. Amirtharajah was referring to the field collection, identification in the presence of a wide variety of microorganisms, and quantification as not being "satisfactory." Laboratory analysis of rotaviruses is practical but their field monitoring may not yet be feasible.

Further, the selection of both poliovirus and rotavirus as test viruses was necessitated by the fact that the surface adsorptive properties and disinfection resistance of the various enteric viruses have been shown to differ significantly by virus group and by strains of a specific virus. While all enteric viruses and their strains could not be economically tested, it was determined by the task force that at least two distinctly different virus types should be tested to achieve some idea of the diversity of removal by the various types of water purifiers. Polio and rota viruses have distinctly different physical and chemical characteristics representative of the viruses of concern. Polioviruses are small single stranded RNA viruses with generally good adsorptive properties to surfaces and filter media while rotaviruses are over twice as large, are double stranded RNA and in some studies have been found to possess less potential for adsorption onto surfaces or filter media. These two viruses also have been demonstrated to have somewhat different disinfection kinetics.

Recommendation:

Retain the rotavirus test requirements.

- H. Definition of microbiological water purifier: One general comment requested redefinition based on "lack of any virus removal" requirement

in the EPA primary drinking water regulations, so that no virus reduction requirement should be included. Also, it was claimed that the separation of purifiers from non-purifiers would be a "disservice to consumers and other users."

Discussion:

Viruses are recognized in the EPA regulations vis-a-vis a proposed recommended maximum contaminant level of zero. Since virus monitoring for compliance with a possible MCL is not yet feasible, a treatment requirement is necessary. Virus control will be considered in the Safe Drinking Water Act filtration and disinfection treatment regulations. The reduction of viruses by treatment is discussed by Amirtharajah (J. AWWA, 78:3:34-49, 1986).

With respect to consumers and other users, we feel that the current definition is appropriate and necessary. The average consumer cannot be expected to know the difference between viruses, bacteria and cysts, or when a raw water will or will not contain any of these organisms. In order to protect the average consumer, the subject units either alone or with supplementary treatment, should be able to cope with all of the specified organisms.

Recommendation:

Retain the current definition for microbiological water purifier.

- I. Coverage of units: Several comments related to the coverage of units. These questions are addressed individually as follows:
 1. Ultraviolet units that are used for supplemental treatment of water from public water system taps would not be covered. We agree that such units are not covered and parenthetical language has been included in Section 1.3.2.3 to clarify this point.
 2. A special status should be given to units which remove Giardia and bacteria but not virus. Specifically, the meaning of Section 1.2.4, "Exceptions," was addressed. The "Exceptions" section was specifically developed to relate to the problem of public water systems having disinfection but no filtration on a surface supply. Cysts alone have been found to survive disinfection treatment and could be present in such treated waters. In this case an effective cyst filter serves an independent, beneficial purpose and should not be required to be a microbiological water purifier. However, such a unit should not be used as sole treatment for untreated raw water. Additional parenthetical language has been added to Section 1.2.4.
 3. The entire treatment unit or system should be tested, not just a single component. We agree but believe that it is sufficiently clear without providing additional language.

4. The protocol should be expanded to cover units for the reduction of TCE, EDB and other chemical pollutants. We felt that the introduction of non-microbiological claims to the standard would make it large, unwieldy and duplicative of an existing third-party standards and testing program (see Section 1.2.5).
- J. Alleged preference of National Sanitation Foundation (NSF) over other laboratories for conducting the microbiological water purifier testing protocol. The comment indicated that we were giving NSF preferential treatment "to the detriment of other laboratories well qualified to perform the required protocol."

Discussion:

We have made appropriate references to existing standards (#42 and #53) developed by the NSF standards development process. Standard 53, the health effects standard, was developed by a broadly based Drinking Water Treatment Units Committee, including representatives from local, State and Federal health and environmental agencies, universities, professional and technical associations, as well as water quality industry representatives. It was adopted in 1982 and the only test from it utilized in our Report has been substantiated as described in Part B of this "Response."

Nowhere in our report have we advocated NSF (or any other laboratory) as the prime or only laboratory for implementing "the required protocol."

Recommendation:

No action needed.

- K. Instruction concerning effective lifetime. One comment described an alternate means for determining lifetime where a ceramic unit is "brushed" to renew its utility and is gradually reduced in diameter. A gauge is provided to measure diameter and to determine when replacement is needed.

Recommendation:

Where a manufacturer provides a satisfactory "other" means of determining lifetime, this should be accepted. Appropriate words have been added to Section 2.4.1.C.

- L. Ceramic candles should not be cleaned during testing because some consumers would not clean them and this would provide the "worst case test." One comment asserted this point.

Discussion:

There is some truth to this proposition. However, the other approach may also have validity. Frequent brushing may reduce filtration efficiency.

In any event, where a manufacturer prescribes filter cleaning and how to do it, and provides a gauge to determine lifetime, we feel the testing program is bound to follow the manufacturer's directions.

Recommendation:

No change needed.

- M. Scaling up or down. One comment points out that one or more manufacturers may vary size of treatment units by increasing or decreasing the number of operative units rather than the size of the operative unit. The comment suggests allowing scaling based on size of operative unit.

Recommendation:

We agree with the comment and have added clarifying words to Section 3.5.3.3.

- N. Turbidity level of "not less than 30 NTU" for ceramic candles or units. One comment states that "Such levels are impossible to utilize in testing mechanical filtration devices which will clog entirely or require such frequent brushing as to render the test impossible as a practical matter."

Discussion:

We recognized the potential "clogging problems" in Section 3.5.1.a(2) where the 30 NTU water is only to be applied immediately before and during each sampling event; the non-sampling turbidity level, which will be applied over 90% of the "on" time, is currently set at no less than 10 NTU.

Turbidity levels of 30 NTU are commonly found in surface waters during heavy rainfall or snow melt. Treatment units may be used under these circumstances, so this challenge level should be retained. However, most usage will occur under background conditions so the non-sampling turbidity levels should be 0.1-5 NTU.

Recommendations:

1. Retain sampling turbidity level of not less than 30 NTU, and
 2. Change non-sampling turbidity to 0.1-5 NTU. Appropriate wording changes have been introduced in Section 3.5.1.a(2) and in Appendix N-1, Section B.
- O. Chlorine in test water #5. One comment asserts that chlorine "tends to increase silver ion leaching activity" and that a high chlorine level should be included in the silver leaching test; but no reference or evidence, however, is provided to back this assertion.

Discussion:

We have no compelling evidence or reason to expect that chlorine will enhance the leaching of silver. However, the prescribed low pH and TDS levels will provide a clearly severe test for silver leaching.

Recommendation:

No change needed.

P. Unnecessary difficulty and expense of test protocols. Several comments were made under this general heading. These comments are outlined and discussed as follows:

1. Too many sampling events are required; sampling of a few units at start, middle and finish should be satisfactory: The committee has carefully laid out the standard and protocol and we feel the minimum sampling plan must be maintained for the consumers' health protection.
2. Three units are too many to study; parallel testing of two units should be satisfactory: For consumer protection, the Disinfectants Branch, Office of Pesticide Programs, has traditionally required the testing of three units. The committee recognizes the additional cost involved in testing a third unit but feels that this will provide a minimum level of assurance to prevent infectious disease and recommends retention of the 3-unit requirement.
3. The protocol requires large tanks and microbiological reseedling on a daily basis: We feel that the tank size requirements are not extreme and can be met by an interested laboratory. With respect to reseedling, it should be pointed out that virus and cyst seeding need only be conducted immediately before and during the sampling "on" period (see Section 3.5.1.b(2)), equivalent to less than 10% of the "on" time. This "spot" seeding for viruses and cysts recognized the expense and difficulty of maintaining large populations of these organisms. Continuous seeding was provided for bacteria because they are easier to grow and maintain and might have the capacity to grow through some units, given enough time and opportunity.
4. Challenge levels of contaminants are too high compared to known environmental conditions and the required log reductions exceed Safe Drinking Water Act requirements: As explained in a footnote to Table 1, Section 2, the influent challenges may constitute greater concentrations than would be anticipated in source waters. These levels are necessary to test properly for the required log reductions without having to utilize sample concentration procedures which are time/labor intensive and which may, on their own, introduce quantitative errors to the microbiological assays. As mentioned in Part I of this paper, the log reductions for bacteria, virus and Giardia have been suggested for public water system

treatment in a paper by Amirtharajah (1986, JAWWA, 78:3:34-49). The reductions in the microbiological purifier standard are entirely compatible with the reductions cited for public water supply treatment.

APPENDIX O
GUIDELINES TO EVALUATE OZONE DISINFECTION

Principal Technical Author: Dr. Ovadia Lev
Division of Environmental Sciences
Hebrew University of Jerusalem
Jerusalem, Israel

APPENDIX O
GUIDELINES TO EVALUATE OZONE DISINFECTION

TABLE OF CONTENTS

	<u>Page</u>
0.1 INTRODUCTION	0.1-1
0.1.1 Background	0.1-1
0.1.2 Objectives of the Recommended Guidelines	0.1-2
0.1.3 EPA's Approach in Setting the Recommended Guidelines	0.1-3
0.1.4 Typical Ozone Disinfection Units	0.1-4
0.2 DETERMINATION OF CONTACT TIME (T)	0.2-1
0.2.1 Background	0.2-1
0.2.2 T_{10} Analysis	0.2-1
0.2.3 Additional Considerations for T_{10} : Multiple Chamber Contactors	0.2-3
0.2.4 Alternative Analysis of Disinfection Kinetics	0.2-7
0.2.5 Continuously Stirred Tank Reactor (CSTR) Approach	0.2-9
0.2.6 Segregated Flow Analysis (SFA)	0.2-10
0.2.7 Relative Inactivation of <u>Giardia</u> Cysts and Viruses	0.2-12
0.2.8 Examples of Determining Contact Time (T)	0.2-13
0.2.8.1 Evaluation Using T_{10}	0.2-13
0.2.8.2 Evaluations Using CSTR Calculations	0.2-16
0.2.8.3 Evaluations Using SFA	0.2-18
0.2.9 Estimating T	0.2-21
0.3 DETERMINATION OF OZONE CONCENTRATION (C)	0.3-1
0.3.1 Introduction	0.3-1
0.3.2 Direct Measurement of C	0.3-2
0.3.3 Estimating C Based on Residual Measurements at the Outlet	0.3-6
0.3.3.1 First Chambers	0.3-6
0.3.3.2 Subsequent Chambers	0.3-7
0.3.4 Estimating C	0.3-10
0.4 SITE SPECIFIC EVALUATION OF OZONE CONTACTORS	0.4-1
0.4.1 Introduction	0.4-1
0.4.2 Site Specific Correlations of C with an Observable Variable	0.4-2
0.4.2.1 Utilizing Off-Gas Measurements	0.4-4
0.4.3 Modeling the Performance of Full Scale Operations	0.4-7
0.4.4 Microbial Indicator Studies to Model Inactivation Contactors	0.4-9

REFERENCES

TABLE OF CONTENTS (Continued)

LIST OF FIGURES

<u>Figure No.</u>	<u>Title</u>	<u>Following Page</u>
0-1	Turbine Contactor, Haworth Water Treatment Plant Hackensack, NJ	0.1-5
0-2	Multiple-Chamber Ozone System, Los Angeles Aqueduct Filtration Plant	0.1-5
0-3	Multiple-Chamber Ozone System, City of Tucson, Arizona	0.1-5
0-4	Multiple-Chamber Ozone System. East Bay Municipal Utility District, Oakland, California	0.1-5
0-5	Schematic of Deep U-Tube Ozone Contactor	0.1-6
0-6	Schematic of In-Line Static Mixer	0.1-6
0-7	Principal of Segregated Flow Analysis	0.2-11
0-8	Segregated Flow Analysis of an Ozone Contactor Tracer Study	0.2-14
0-9	Tracer Study of Sturgeon Bay Ozone Contactor	0.2-15
0-10	Segregated Flow Analysis of Ozone Contactor - Integration of Survival Efficiency.	0.2-20
0-11	Segregated Flow Analysis of Ozone Contact Chamber	0.2-20
0-12	Decision Tree for Estimating T	0.2-21
0-13	Flow Configurations in Ozone Contact Chambers.	0.3-1
0-14	Direct Measurements for Determining T	0.3-5
0-15	Ozone Concentration Profiles	0.3-8
0-16	Decision Tree for Estimating T	0.3-10
0-17	Example of Empirical Correlation of Residual Ozone and Off-Gas	0.4-6

TABLE OF CONTENTS (Continued)

LIST OF TABLES

<u>Table No.</u>	<u>Title</u>	<u>Following Page</u>
0-1	Recommended Procedures to Calculate Contact Time (T)	0.2-2
0-2	CT Values for Inactivation by Ozone	0.2-7
0-3	k Values for Inactivation by Ozone	0.2-7
0-4	Spread Sheet Notations for SFA	0.2-18
0-5	Segregated Flow Analysis of an Ozone Disinfection Contactor at Hackensack	0.2-20
0-6	Correlations to Predict C Based on Outlet Ozone Concentrations	0.3-6
0-7	Henry's Constants for Ozone	0.4-5
0-8	Empirical Correlation Between C_{out} and y_{out}	0.4-6

0.1 INTRODUCTION

0.1.1 Background

The Surface Water Treatment Rule (SWTR) specifies overall minimal removal/inactivation efficiencies by filtration and disinfection for Giardia cysts and viruses. The SWTR uses the "CT" concept to predict inactivation efficiencies of microorganisms by disinfection. "CT" represents the product of contact or exposure time ("T") and the concentration of disinfectant ("C") during disinfection. The Guidance Manual suggests design, operating and performance criteria for specific surface water quality conditions to provide compliance with the SWTR. Appendix C of the Guidance Manual recommended guidelines for the determination of contact time (T_{10}) for the disinfection of drinking water. T_{10} is the time defined to assure that 90 percent of the water that enters the disinfection chamber will remain for at least T_{10} minutes. This appendix recommends additional procedures which may be used for consistent determination of the C and T for systems using disinfection by ozone.

Ozone has unique characteristics and warrants special consideration for estimating inactivation efficiencies. In developing these recommended procedures, EPA addressed the following complications that are specific to ozone disinfection and distinguish it from other typical disinfection processes.

- Despite the long operational experience with ozone disinfection, the data regarding performance of ozone as a disinfectant are rather limited. Most of the available inactivation rate data are derived from laboratory conditions which are substantially different than full scale continuous operation, generally more so than for other disinfectants.
- From a technical point of view, disinfection of drinking water by ozone is more complicated than disinfection by other common disinfectants because of ozone's unique gas-liquid mass transfer characteristics. Ozone requires sophisticated mass transfer equipment to introduce it into water, because of the relatively low ozone concentration in the feed gas. Ozone is a powerful oxidant, that reacts rapidly with organic and inorganic substances present in the water and undergoes auto-decomposition. Therefore, it's residual is much less stable than that of other disinfectants and dissipates rapidly.

- Ozone contactors exhibit more diversified types of flow configurations relative to the flow pattern in contactors for the other disinfectants. The flow configuration often ranges from an almost continuously stirred tank reactor (CSTR) to an almost ideal plug flow configuration, making the determination of contact time for ozonation more complex than for other disinfectants.
- Ozone contactors are closed vessels because of ozone's toxicity. The contactors have limited access for measurement of the ozone concentration profile within the contactor. Gas bubbles also may interfere with the determination of the dissolved ozone concentration, if the bubbles are entrapped during sampling.
- Ozone technology is still evolving and new types of ozone contactors are being developed. These guidelines should not set unnecessary obstacles that will inhibit engineering progress and prevent innovative designs of disinfection systems.

EPA's procedures for determining C and T for disinfection with ozone differ from those recommended for systems using chlorine, chloramines or chlorine dioxide as disinfectants. The CT evaluation procedures presented in previous chapters of the Guidance Manual are not appropriate for ozone disinfection because they would result in excessive ozone dosages. Excessive ozone doses result in high energy requirements and costs and may lead to unnecessary production of ozonation by-products which may have associated health risks. Additionally, excess dissolved or entrained ozone should be destroyed or removed before reaching the first drinking water consumer or plant personnel, in order to prevent health risks. Therefore, excessive dosage of ozone may require an additional unit operation to destroy the remaining residual ozone. This process is expensive and may not be necessary if guidelines such as those presented in this section are used for compliance with the SWTR.

0.1.2 Objectives of the Recommended Guidelines

The recommended guidelines were developed to assure compliance with the SWTR for the whole range of flow rates, flow configurations and water quality conditions that may be encountered with ozone disinfection of drinking water. The primary goal of these guidelines is to assure

compliance with the SWTR even under "worst case" conditions. Without compromising this primary goal, these guidelines were developed to meet the following criteria:

1. **Simplicity:** The guidelines for selecting contact time (T) and concentration (C) have to be easily understood by practitioners, even by those who do not have an engineering background.
2. **Implementation:** The procedure to estimate concentration and time should be easily implemented, even by water utilities that have only limited engineering and technological means.
3. **Economics:** The guidelines should be designed to minimize capital and operating costs and to minimize ozone consumption. The guidelines should be flexible enough to allow systems to take advantage of site specific characteristics of the treated water and the various designs of ozone contactors.

0.1.3 EPA's Approach in Setting the Recommended Guidelines

EPA is aware that the current technological knowledge is insufficient to formulate a consistent and efficient single set of general rules that will achieve these conflicting goals and still guarantee compliance with the SWTR. Therefore, EPA developed two alternative sets of guidelines that systems may use depending on their technological resources:

- Alternative 1: General guidelines which assure compliance with the SWTR regardless of the site specific conditions,
- Alternative 2: A sophisticated evaluation procedure that water utilities may use to take advantage of their site specific conditions.

These guidelines are considered to be state-of-the-art. As more information becomes available, more accurate approaches and models may be developed. A brief description of the current alternatives follows.

Alternative 1 - General Guidelines

This alternative consists of a simple set of general guidelines that assure compliance with the SWTR even under worst case conditions. These guidelines were developed to emphasize generality and simplicity. However, they may not result in the lowest cost alternative(s).

The second and third sections of this Appendix contain detailed descriptions of the general guidelines. Section 0.2 contains procedures to estimate the contact time (T) and Section 0.3 contains procedures to calculate the concentration (C) in ozone contactors based on simple measurements of some parameters. The basis for these general guidelines is discussed in two papers (Lev and Regli, 1990a,b).

Alternative 2 - Site Specific Evaluation Procedures

This alternative consists of a more sophisticated set of evaluation procedures to characterize the performance of ozone contactors and thereby take advantage of site specific conditions. EPA recommends that systems be given opportunity to prove by further experimental and analytical data that the performance of their ozone contactors are better than the performance predicted by the first alternative, thereby allowing a system to minimize costs while providing adequate treatment.

Section 0.4 outlines recommended procedures for demonstrating that ozone contactors achieve better performance than that predicted by the first alternative.

0.1.4 Typical Ozone Disinfection Units

Several types of ozone contactors are currently in use for disinfection of drinking water in the United States. Other types of contactors are being designed or are being used for disinfection of treated sewage effluents. The following characteristics illustrate the diversity of ozone contactors:

- The capacity of ozonation systems ranges from less than 1 million gallons per day (mgd) up to 600 mgd.
- The volume of ozone contactors ranges from less than 35 cubic feet up to more than 35,000 cubic feet for a single chambers.
- The ozone gas stream may be introduced into the water by several ways including porous diffusers, submerged turbines and gas injectors.
- Ozone contactors include single or multiple gas/liquid contact chambers.

Four typical ozone contactors currently in use or in design in the United States are shown on Figures 0-1 through 0-4. Figure 0-1 presents a schematic of an aspirating turbine contactor, operating in countercurrent flow. A turbine agitator is used to introduce the ozone into the contactor and to mix the liquid phase. This unit may serve as the first ozone chamber in a series of chambers or as a single chamber. The unit shown in this figure is from the Hackensack Water Company's Haworth Plant at Haworth, New Jersey. The turbine chamber is followed by a reactive chamber to provide additional contact time. Studies conducted in the full scale turbine agitated contactor demonstrated that even when the ozone demand was high, the dissolved ozone concentration was almost constant throughout the contactor as a result of the vigorous action of the turbine (Schwartz et al, 1990).

The 600 mgd ozone system of the city of Los Angeles is comprised of four parallel contactors each consisting of six chambers. A schematic of one of these contactors is presented on Figure 0-2. (Stolarik and Christie, 1990) As indicated on this figure:

- An oxygen stream containing a few percent by weight of ozone is compressed through bubble diffusers into the first and third chambers of the contactor.
- The second and fourth chambers are used to provide contact time, without supplying additional gas to the liquid stream.
- The size of the first three gas/liquid contact chambers is 20,400 cubic feet each.
- The fifth and sixth chambers are the ozonated water channel and the rapid mixer basins.
- The liquid and gas streams in the first and third chambers flow in a counter-current pattern; the gas stream flows upward and the water stream flows downward.

As illustrated on Figure 0-3, a similar design approach was taken by the City of Tucson, Arizona. This contactor is comprised of five chambers, all of which are equipped with gas diffusers. The sixth chamber has no diffusers. The flow in all six chambers is counter-current flow. These counter-current chambers are separated by narrower co-current liquid channels in which the water flows upward to the inlet of the next chamber.

The East Bay Municipal Utility District Oakland, California is currently designing two 60 mgd ozone contactors, the first of which is to be operational in 1991. As illustrated on Figure 0-4, the contactor includes three ozone gas/liquid chambers followed by three more reactive chambers to provide additional contact time. The first and third chambers are counter-current and the second chamber is co-current. In the latter, the water and the gas bubbles flow in the same direction. Hydrogen peroxide can be added at the outlet of the contactor to dissipate any residual dissolved ozone.

The following types of contactors are already used in other parts of the world, but have not yet been installed in the United States:

- The Deep U Tube contactor shown on Figure 0-5, is comprised of two concentric flow tubes. Water and gas streams are introduced at the top of the inner tube and the mixture is pumped 10 to 30 meters downwards at a velocity greater than the rise rate of the gas. After reaching the very bottom of the contactor the mixture flows up in the outer section of the contactor. The Deep U-tube is basically a co-current operation taking advantage of the increased mass transfer at high pressures.
- The Static Mixer (shown on Figure 0-6) consists of a flow tube equipped with baffles to produce efficient contact between the liquid and the gas streams. This installation is gaining popularity in Europe particularly for small and medium size disinfection units. Here the flow is basically co-current, the liquid and gas flow is in the same direction, through a tube equipped with baffles that create turbulence and thus increases the rate of gas-liquid mass transfer. The ozone is applied to the water prior to the mixer either through an eductor or a diffuser. Following dissolution through the mixer, the water flows through a pipeline in plug flow.
- Some contactors, particularly for disinfection of wastewater effluents, use packed beds to increase mass transfer. Co-current or counter-current flow configuration may be used.

The guidelines were developed to represent four different flow conditions in ozone contactors. However, other types of contactors or flow conditions may still use the same guidelines if the features of the gas-liquid flow configuration as presented in Section 0.4 of this appendix are taken into account.

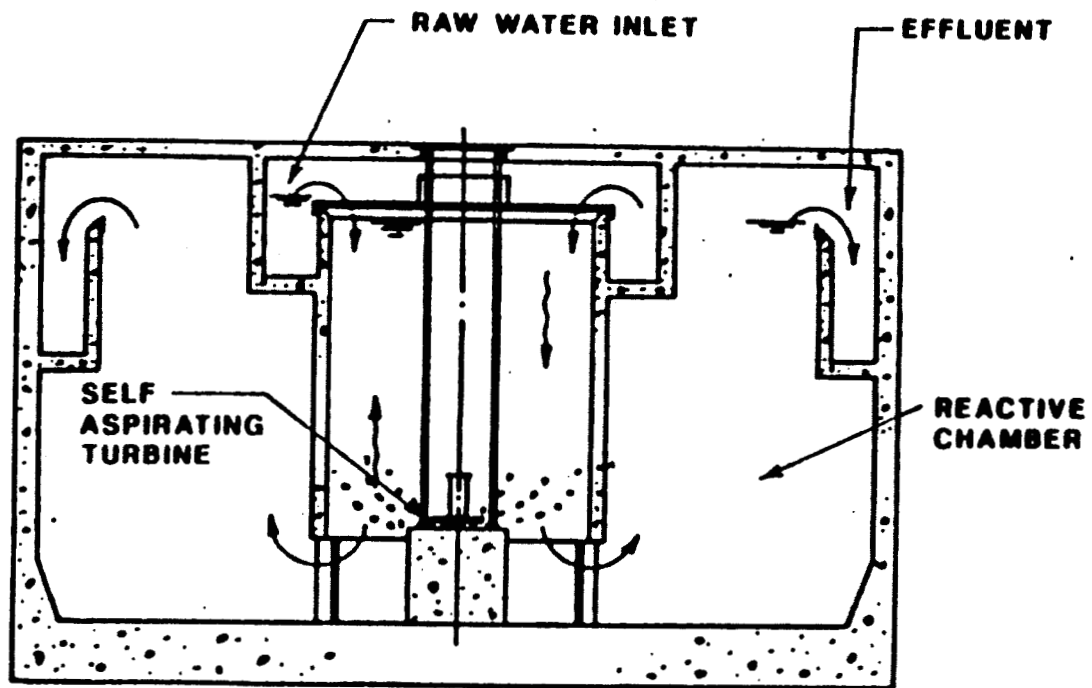

**FIGURE 0-1 - TURBINE OZONE CONTACTOR,
HAWORTH WATER TREATMENT PLANT
HACKENSACK, NJ**

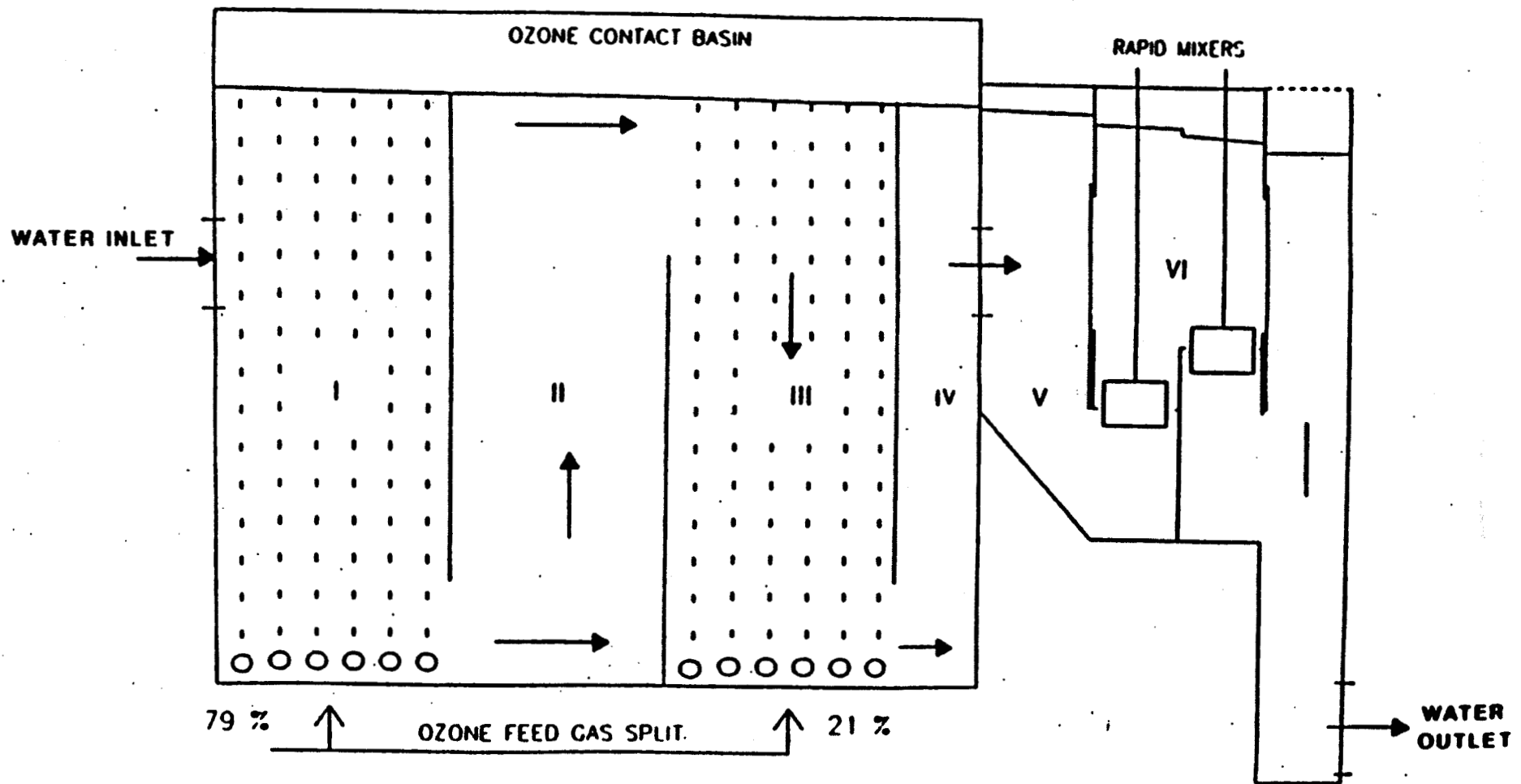

FIGURE 0-2 - MULTIPLE-CHAMBER OZONE SYSTEM, LOS-ANGELES AQUEDUCT FILTRATION PLANT, STOLARIK et al. (1988)

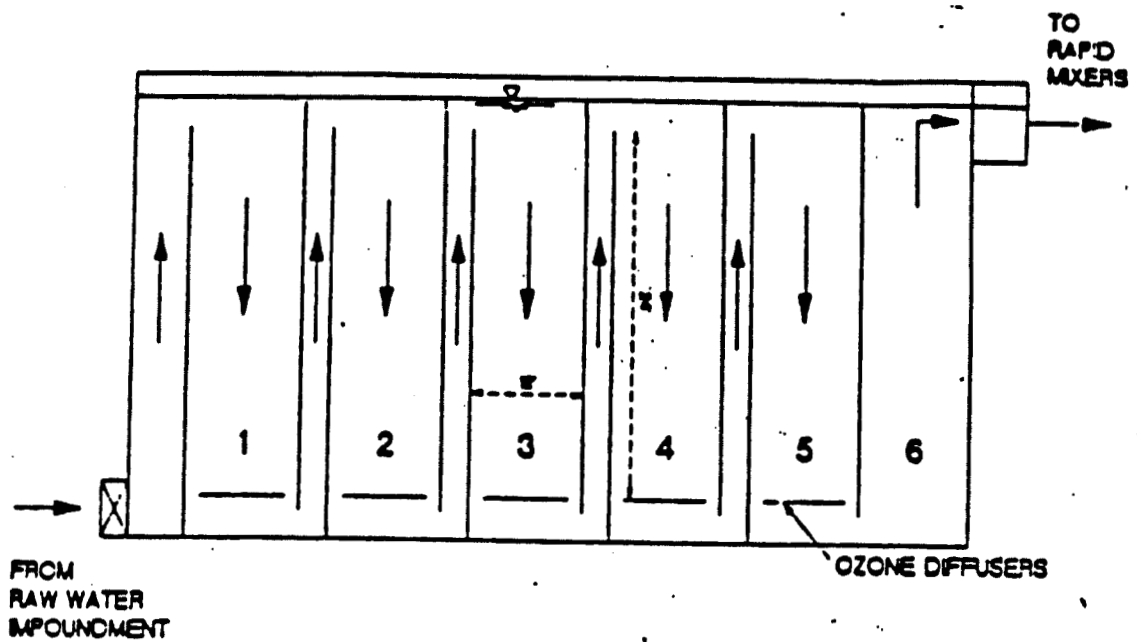

FIGURE 0-3 - MULTIPLE-CHAMBER OZONE SYSTEM, CITY OF TUCSON, ARIZONA, JOOST et al. (1989)

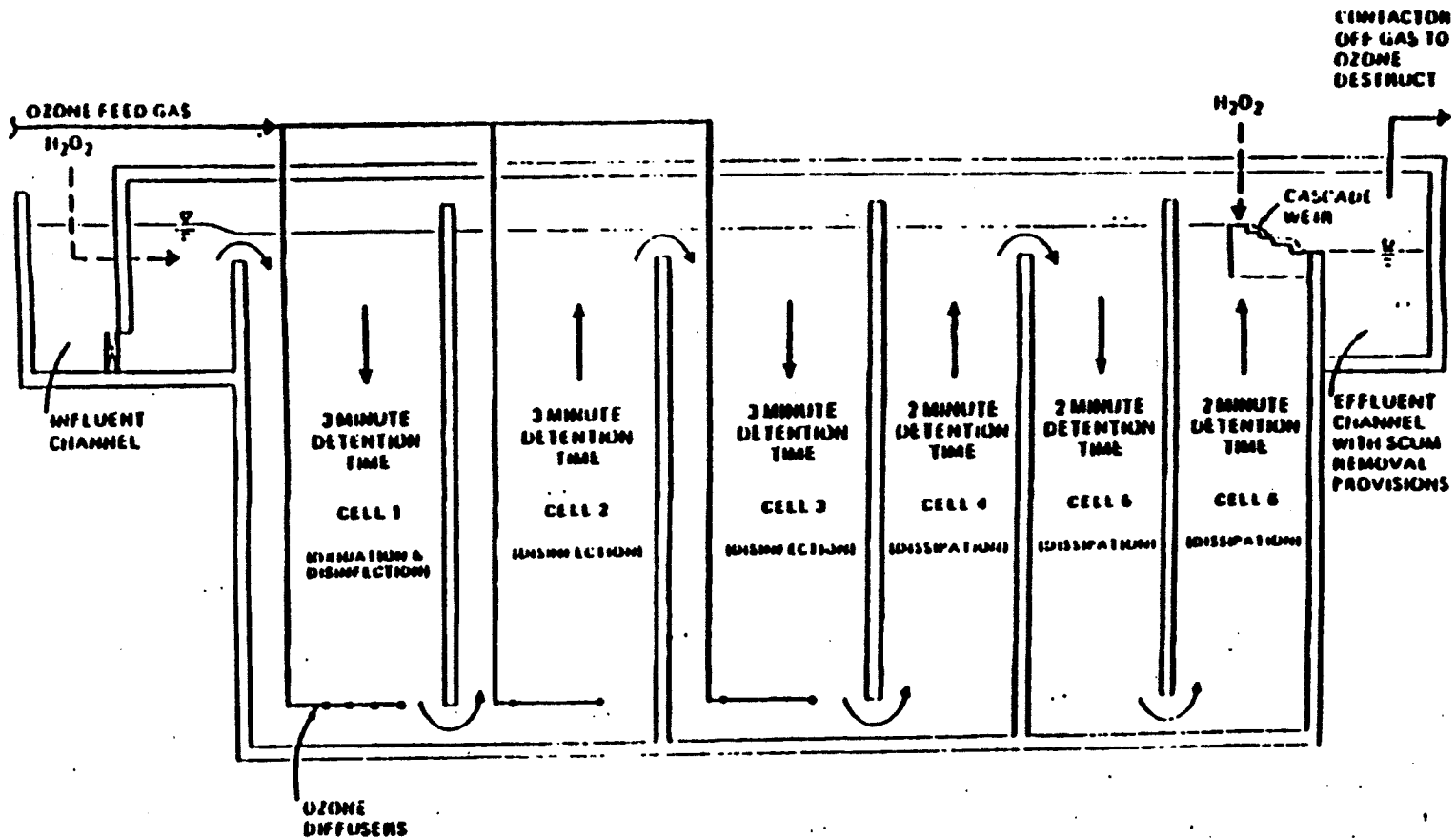

FIGURE 0-4 - MULTIPLE-CHAMBER OZONE SYSTEM, EAST BAY MUNICIPAL UTILITY DISTRICT, OAKLAND, CALIFORNIA, CARNS (1990)

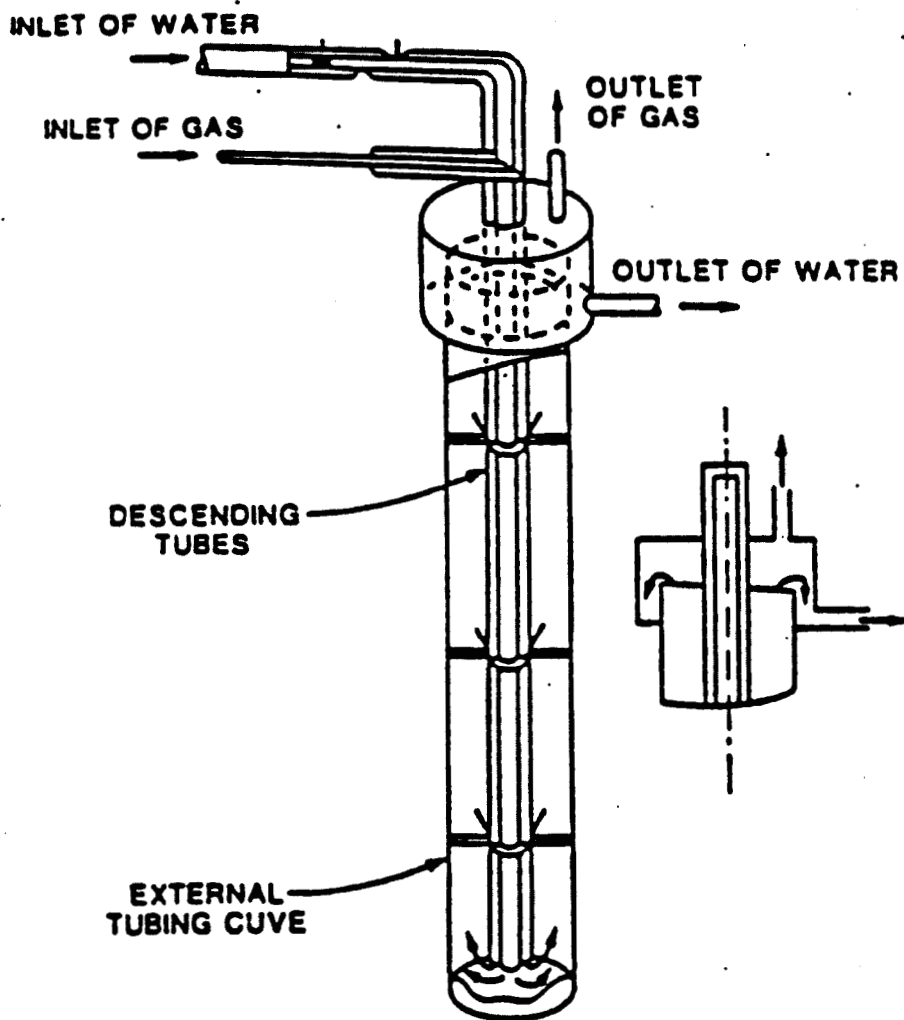

FIGURE 0-5 - SCHEMATIC OF THE DEEP U-TUBE OZONE CONTACTOR, ROUSTAN et al. (1987)

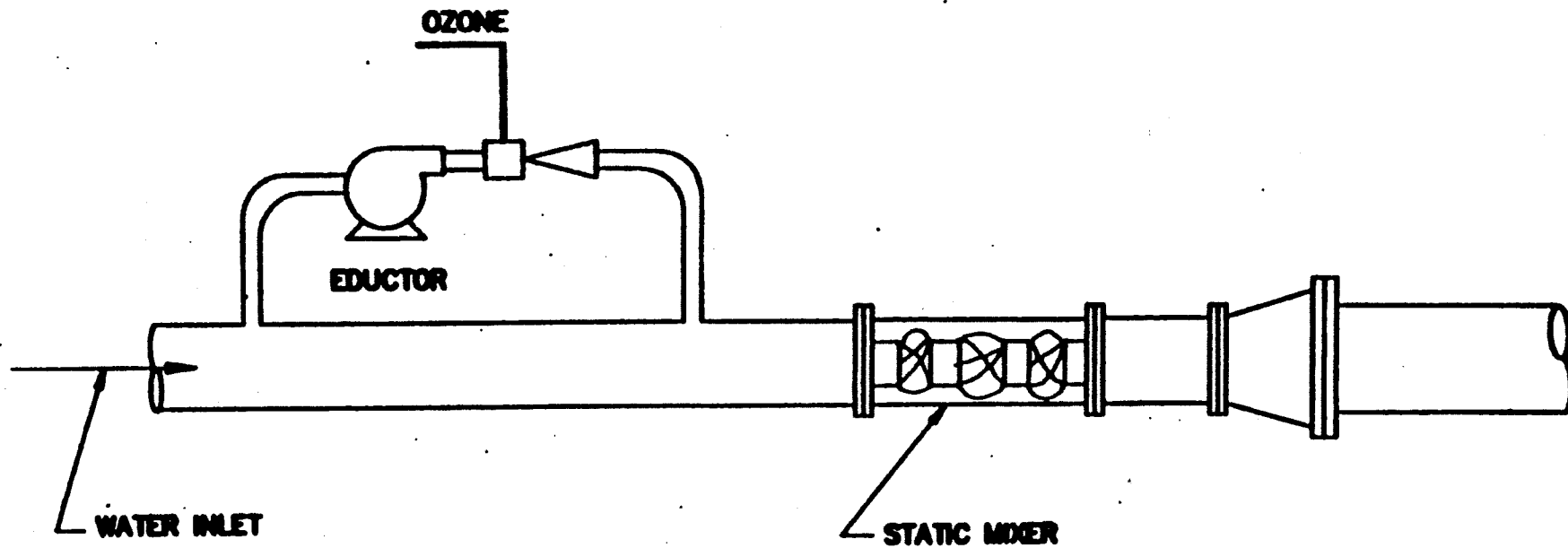

FIGURE 0-6 - SCHEMATIC OF IN-LINE STATIC MIXER

0.2 DETERMINATION OF CONTACT TIME (T)

0.2.1 Background

The hydraulic characteristics in ozone contactors range from an almost Continuous Stirred-Tank Reactor (CSTR) to an ideal plug flow configuration. Because the T_{10} approach may not be adequate for determining the inactivation provided for systems resembling a CSTR, and because the T_{10} approach is overly conservative in other cases, EPA recommends the following three numerical methods to predict the contact time (T) in ozone contactors:

T_{10} : The T_{10} method discussed in Appendix C (and in Section 0.2.2) is a good measure to characterize the contact time in most cases. However, this method reduces the possibility of complying with the SWTR for systems that have relatively high back-mixing and require high inactivation levels.

Segregated Flow Analysis (SFA): (See Section 0.2.6) This is an alternative procedure to calculate the disinfection contact time. This procedure is applicable only to systems that have good data from tracer studies of high resolution as explained in Section 0.2.6.

CSTR: The Continuously Stirred-Tank Reactor (CSTR) method described in Section 0.2.5, assumes the ozone contactor behaves as a CSTR. This procedure is extremely conservative. However, no apparent simplified analysis is currently available to make it less conservative. The CSTR approach should be used only when:

- Other predicting techniques are not recommended,
- The required inactivation level is very low, or
- Systems cannot afford to get good tracer study data for other methods.

Systems may choose the optimal method for their situation based on the available data to perform the calculations. A discussion of each is presented below.

0.2.2 T_{10} Analysis

The simplest method of calculating the contact time, T, of microorganisms in a contactor is by the T_{10} approach. T_{10} is defined as the detention time to assure that 90 percent of the liquid that enters the

contactor will remain at least T_{10} minutes in the contactor. A system achieving a CT_{10} corresponding to X percent inactivation, will assure that 90 percent of the water passing through the contactor is receiving at least X percent inactivation, while 10 percent of the water will receive less than X percent inactivation.

When conducting a step-input tracer study, T_{10} is the time interval required for the outlet tracer concentration to achieve 10 percent of its ultimate response, following an inlet step addition. Appendix C of this manual contains procedures to conduct and evaluate tracer studies for the determination of T_{10} . Appendix C also contains procedures to estimate the T_{10} of contactors based on their baffling conditions and flow configuration.

The results of tracer studies conducted on several ozone contactors (Stolarik and Christie, 1990, Schwartz et al, 1990, Rosenbeck et al, 1989) indicate that high quality tracer data on ozone contactors can be obtained and that T_{10} can be estimated with high precision, but to a lesser degree when T_{10} is less than one minute.

T_{10} is a good measure of the contact time in most contactors and the safety margin provided by using T_{10} compensates for the inferior performance of contactors with a high degree of short-circuiting and backmixing relative to contactors that approach plug flow conditions. (see Lev and Regli, 1990a, for further detail.) However, for contactors with a high degree of short-circuiting and a need to provide a high level of inactivation, this safety margin fails to compensate for the effect of backmixing. In such cases, approximately 10 percent of the water passing through the contactor receives significantly less than the inactivation indicated by CT_{10} . In these cases, either the SFA or the CSTR approach should be used for determining the contact time.

The recommended alternatives for determining the contact time (T) for various conditions of T_{10} versus hydraulic detention time (HDT) are presented in Table 0-1. HDT is determined by dividing the liquid volume of the contactor by the rate of flow through the contactor. As illustrated in this table:

TABLE O-1

Recommended Procedures to Calculate the Disinfection Contact Time (T)

Condition:	$T_{10} < (HDT)/3$ & $-\text{Log}(I/I_0)^{(1)} < 2.5$	$T_{10} < (HDT)/3$ & $-\text{Log}(I/I_0)^{(1)} \geq 2.5$	$T_{10} > (HDT)/3$
Recommended Methods:	T=T ₁₀		T=T ₁₀
	SFA ⁽²⁾	SFA ⁽²⁾	SFA ⁽²⁾
	CSTR ⁽³⁾	CSTR ⁽³⁾	CSTR ⁽³⁾

Notes:

1. Required level of inactivation in logs of either Giardia lamblia cysts or viruses whichever value is greater;
I = # live organisms in outlet of ozone contactor and
I₀ = # live organisms in inlet to ozone contactor
2. High resolution tracer characterization of the ozone contactor must be available.
3. The CSTR method is extremely conservative and should be avoided when alternative approaches are possible.

- The T_{10} method is applicable for systems that are required to achieve less than a 2.5-log inactivation of Giardia cysts even if the flow configuration in their ozone contactor approaches that of a CSTR, such as disinfection in contactors using turbine agitators.
- Likewise, the T_{10} approach is appropriate for systems demonstrating T_{10}/HDT greater than 1/3 regardless of the required level of disinfection.
- Systems for which the T_{10} approach is appropriate to have the option of applying either the SFA or CSTR analysis. The method resulting in the highest T value, or thereby the lowest C value may then be followed.

The SFA or CSTR should be used in lieu of T_{10} when the:

- Level of inactivation required for Giardia cysts and/or viruses is 2.5-log or higher
- T_{10}/HDT is less than 1/3.

Systems should be aware that the 2.5-log inactivation guideline refers to the inactivation provided by the ozone system alone regardless of inactivation provided by other disinfectants. For example, if a system requires an overall inactivation of 3-log and provides 1-log inactivation by chlorine, then a 2-log inactivation is required by ozone and the T_{10} approach can be used.

Examples for applying the different methods of calculation for T are included in Section 0.2.8.

0.2.3 Additional Considerations for T_{10} : Multiple Chamber Contactors

This section provides guidelines for computing T_{10} for several contactors in series. The main shortcoming of the T_{10} approach is the inherent non-linearity of this measure. In contrast to the HDT, which is a linear measure, T_{10} 's of individual subunits do not sum up to give the T_{10} of the overall unit. For example:

- The HDT of two equal CSTRs in series is exactly twice the HDT of each CSTR.
- The T_{10} for the same two CSTRs in series is more than twice the sum of the individual T_{10} 's.

This raises some practical questions:

- How should the T_{10} of a multiple-chamber contactor be determined using tracer studies?
- Is it necessary to conduct individual tracer studies for each chamber or is it sufficient to conduct an overall study of the whole contactor?
- How can the contact time of one chamber be determined based on the T_{10} of the overall system?

Conducting tracer studies of individual chambers in a multiple chamber ozone contactor is likely to be difficult. In addition, an analysis conducted by Lev and Regli (1990a) indicates that the computation of the contact time (T) based on tracer studies of the individual chambers is likely to lead to over design. The excess volume of a system designed by summing the T_{10} s of the separate chambers may be up to 9.5 times higher than one designed by the overall T_{10} approach. Therefore, EPA recommends the use of an overall tracer study of the whole contactor, in order to lower operation costs and to avoid overly complex tracer studies.

Disinfection credits for a multiple chamber contactor should be based only on the active chambers, those which have a detectable ozone residual. Based on the recommendation to use overall tracer studies, guidelines are needed for determining the disinfection credit for the active part of a system based on overall tracer studies. The average concentration in the individual chambers of a multiple-chamber system may deviate considerably from one another. Therefore, systems must be able to assign contact times for each chamber.

Lev and Regli, (1990a) evaluated the consequences of using a linear approximation based on relative contact chamber volumes and overall T_{10} of the contactor to determine the contact time of individual chambers in an ozone contactor:

$$T_{10, \text{chamber}} = (V_{\text{chamber}}) (T_{10, \text{total}}) / (V_{\text{total}}) \quad (1)$$

Where:

$T_{10, \text{chamber}}$ = An approximation for the contact time of one chamber.

$T_{10, \text{total}}$ = T_{10} of the entire multi-chamber ozone contactor as determined by tracer studies

V_{chamber} = Volume of the individual chamber

V_{total} = Overall volume of the multi-chamber ozone contactor

They demonstrated that such linear extrapolation may lead to an underestimate of the required T. This underestimate can be significant when the concentration in the different chambers deviate considerably from each other. This would be the case when the residual ozone concentration in one chamber is zero.

Considering the various safety margins that are included in the T_{10} approach, and considering the practical complexity involved in conducting separate tracer studies, EPA recommends the use of the linear approximation described in Equation 1 provided that the volume of the portion of the contactor that has zero residual ozone is less than half of the overall volume of the ozone contactor:

$$V_{\text{inactive chamber}} / V_{\text{total}} < 0.5$$

Where:

$V_{\text{inactive chamber}}$ = The volume of the chambers in the contactor where the ozone concentration is zero

V_{total} = The volume of the chambers with a residual

The following examples illustrate the computation of the overall inactivation performance of multiple-chamber systems using the linear approximation of Equation 1:

Example 0.2-1 Linear approximation to predict T_{10}

- An ozone contactor has three chambers in series. Each chamber has a volume of 353 cubic feet.

- The average ozone concentration in each chamber is:
 - First chamber: $C_1=0$ mg/L ozone.
 - Second chamber: $C_2=1$ mg/L ozone.
 - Third chamber: $C_3 =0.5$ mg/L ozone.
- C_1 , C_2 and C_3 are the average concentrations, determined as described in Section 0.3.
- The utility measured $T_{10} = 5$ min for the entire ozone contactor.
- The volumetric fraction of the chamber which has no ozone residual is $V_1/(V_1+V_2+V_3) = 0.33$ which is less than the 0.5 guideline. Therefore it is permissible to use Equation 1 in order to estimate the CT achieved in the ozone contactor.
- The total CT achieved by the ozone contactor is:

$$CT = (C_2)[(T_{10,total})(V_2)/(V_{total})] + (C_3)[(T_{10,total})(V_3)/(V_{total})]$$

$$CT = (1)[(5)(10)/(30)] + (0.5)[(5)(10)/(30)] = 2.5$$
- The CT achieved by the ozone contactor is 2.5 mg-min/L.

Example 0.2-2 Linear approximation not applicable

- An ozone contactor consists of:
 - A chamber with a volume of 70 cubic feet and equipped with a turbine agitator
 - Followed by a second chamber with a volume of 200 cubic feet.
- The first chamber has an ozone residual of 0.5 mg/L and the second chamber has an ozone residual of zero
- The $T_{10,total} = 8$ min for both chambers at the peak flow rate
- The volumetric fraction of the chamber with no ozone residual is $200/270 = 0.74$ which is greater than 0.5 of the total volume. Therefore, the use of Equation 1 to approximate the T_{10} of the chamber that contains an ozone residual is not recommended.
- The system may estimate its performance by either the CSTR approach taking into account only the detention time of the first chamber or conduct tracer studies of the first chamber.

0.2.4 Alternative Analysis of Disinfection Kinetics

The CSTR and the SFA approaches utilize the Chick-Watson inactivation rule directly rather than relying on the CT approach. The following section describes this alternative approach to represent the disinfection kinetics.

The Guidance Manual recommends that systems should calculate the inactivation level in their disinfection contactors by the CT approach. Table O-2 presents CT data corresponding to specified inactivation levels of Giardia cysts and viruses by ozone. An alternative way to present the same information is by tables of the kinetic coefficients used to calculate the CT values.

The CT values presented in Table O-2 were calculated based on batch-reactor experimental information that was fitted into a logarithmic correlation according to a first order Chick-Watson's rule (Chick, 1907; Watson 1908; and Hoff, 1987):

$$\log(I/I_0) = -k CT \quad (2)$$

Where:

- I/I_0 = Survival ratio of the Giardia cysts or viruses
- C = Residual concentration of ozone in mg/L
- T = Exposure time in min.
- k = A kinetic coefficient which characterizes the specific rate of inactivation of the microorganisms at the appropriate temperature and pH.

Solving Equation 2 for k yields:

$$k = \frac{-\log(I/I_0)}{CT} \quad (3)$$

Equation 3 can be used to calculate k values corresponding to the CT values in Table O-2. Table O-3 summarizes these k values. Equation 3 may also be used to transform inactivation levels (I/I_0) to CT values and vice versa.

The following example illustrates the use of the values presented in Table O-3 to calculate the performance of multiple-chamber ozone contactors:

Example 0.2-3 Multiple-chamber Ozone Contactor

- An ozone contactor consists of three chambers in series .
- Temperature is 5 C.
- The first chamber has a 10 percent survival ratio for Giardia cysts, or $(I/I_0) = 0.1$, which also corresponds to 90 percent inactivation
- The second chamber has an $I/I_0 = 0.07$
- The third chamber has an $I/I_0 = 0.03$
- The total inactivation may be calculated by either summing CT's or summing logs of inactivation, as presented below.
- Summing CT's:
 - At 5 C the k for Giardia cysts = 1.58
 - The survival fractions are:
First Chamber = 0.1
Second Chamber = 0.07
Third Chamber = 0.03
 - Therefore, the CT values in each of the chambers are:
 - First chamber:
 $CT = -\log(I/I_0)/k = -\log(0.1)/(1.58) = 0.63$
 - Second chamber:
 $CT = -\log(I/I_0)/k = -\log(0.07)/1.58 = 0.73$
 - Third chamber:
 $CT = -\log(I/I_0)/k = -\log(0.03)/1.58 = 0.96$
 - Total CT is : $0.63 + 0.73 + 0.96 = 2.32$
 - As indicated in Table 0-2, a CT of 2.32 is sufficient to achieve a 3-log inactivation of Giardia cysts.
- Summing logs of inactivation:
 - First chamber: $-\log(I/I_0) = -\log(0.1) = 1$
 - Second chamber: $-\log(I/I_0) = -\log(0.07) = 1.15$

TABLE 0-2
CT VALUES FOR
INACTIVATION BY OZONE

<u>Giardia</u> <u>Inactivation</u>	<u>Temperature (C)</u>					
	<u><=1</u>	<u>5</u>	<u>10</u>	<u>15</u>	<u>20</u>	<u>25</u>
0.5 log	0.48	0.32	0.23	0.16	0.12	0.08
1 log	0.97	0.63	0.48	0.32	0.24	0.16
1.5 log	1.5	0.95	0.72	0.48	0.36	0.24
2 log	1.9	1.3	0.95	0.63	0.48	0.32
2.5 log	2.4	1.6	1.2	0.79	0.60	0.40
3 log	2.9	1.9	1.4	0.95	0.72	0.48
<u>Virus</u> <u>Inactivation</u>						
2 log	0.9	0.6	0.5	0.3	0.25	0.15
3 log	1.4	0.9	0.8	0.5	0.4	0.25
4 log	1.8	1.2	1.0	0.6	0.5	0.3

TABLE O-3

k Values for Ozone Inactivation⁽¹⁾

TEMPERATURE (C)	<u>0.5</u>	<u>5</u>	<u>10</u>	<u>15</u>	<u>20</u>	<u>25</u>
Inactivation of <u>Giardia</u> cysts	1.03	1.58	2.08	3.12	4.17	6.25
Inactivation of Viruses	2.22	3.33	4.00	6.67	8.00	13.3

⁽¹⁾ $k = -\log(I/I_0)/(CT)$ in L/mg-min. When Chick's rule is represented by the formula $\ln(I/I_0) = -K CT$ (\ln stands for the natural logarithm) then k should be calculated by $k = 2.303(K)$

- Third chamber: $-\log(I/I_0) = -\log(0.03) = 1.52$
- The total logs of inactivation is:

$$-\log(I/I_0) = 1 + 1.15 + 1.52 = 3.67,$$
- The 3.67-log inactivation of Giardia cysts is higher than the required 3-log inactivation

0.2.5 Continuously Stirred-Tank Reactor (CSTR) Approach.

The CSTR method assumes that the flow configuration in the ozone contactor approaches that of completely stirred reactor. In most cases, this calculation method is the most conservative approach. Studies by Schwartz et al (1990) suggest that well-operated turbine contactors approach ideal CSTR characteristics and the CSTR calculation is appropriate. In some cases, CSTR calculations offer the only apparent method to evaluate the performance of the ozone contactors. CSTR calculations should be used under the following conditions if systems have no other means for demonstrating the inactivation efficiency.

- Tracer data are not available,
- The required inactivation level is greater than 2.5-log, and ozone disinfection is applied in a single chamber contactor with $T_{10}/\text{HDT} \leq 1/3$.
- If either the required inactivation level is less than 2.5-log or $T_{10}/\text{HDT} > 1/3$ then the inactivation predicted by CT_{10} is appropriate provided that tracer data are available. If high resolution tracer data are available then the SFA method can be applied regardless of the level of inactivation required or the ratio of T_{10}/HDT .

In some cases, systems may actually receive more credit by using the CSTR approach than by using the T_{10} approach. Higher credits result when a low level of ozone disinfection such as 0.5-log is required and mixed contactors are used.

When using the CSTR approach, the inactivation performance should be evaluated for viruses and Giardia cysts, regardless of which required CT is higher. This recommendation results from the influence of flow characteristics on contactor performance, as discussed in Section 0.2.7.

The performance equation for a CSTR is based on two important assumptions:

1. The concentration of disinfectant and microorganisms is homogeneously distributed in the contactor.
2. First order Chick-Watson's law applies. That is, the rate of inactivation of the microorganisms is approximately proportional to the concentration of the microorganisms and the concentration of disinfectant.

The performance of a CSTR contact chamber is given by:

$$(I/I_0) = 1/[1 + 2.303(k)C(HDT)] \quad (4)$$

Where:

- k = kinetic coefficient for microorganism inactivation [k values are listed in Table O-4 (L/mg-min)]
- (I/I₀) = Survival ratio of organisms
- C = Average concentration of disinfectant (mg/L)
- HDT = Hydraulic detention time (min)

Equation 4 may also be used to calculate the ozone concentration that is required to achieve a specified level of inactivation for a given HDT or to compute the HDT required to achieve a desired inactivation level for a given ozone concentration. Equation 5 restates Equation 4 for use in determining C or HDT

$$C(HDT) = [1 - (I/I_0)]/[2.303 k (I/I_0)] \quad (5)$$

The effects of mixing on improving disinfection effectiveness may be very significant in CSTR contactors, and are not accounted for in this model.

Examples demonstrating how to calculate the operating conditions necessary to meet the required inactivation levels by the CSTR approach are included in Section 0.2.8.2.

0.2.6 Segregated Flow Analysis (SFA)

SFA is a method that is often used to characterize chemical reactions. Better approximations may be determined through analysis and modelling of the specific details of the flow pattern in the ozone

contactor, but such modelling cannot be done based on tracer studies alone, as the SFA can. Comprehensive descriptions of the SFA can be found in several references including Levenspiel (1972) and Seinfeld and Lapidus (1984). The SFA assumes that the inactivation in a contactor can be determined by the product of the probabilities of two events: the probability distribution for water to remain in the contactor; and the probability distribution for organisms to survive as they pass through the contactor.

The first probability function describes the chances of a microorganism remaining in the contactor for a specified time period. The water passing through the contactor has a probability distribution, determined by tracer studies which indicate the detention time for each fraction of the flow through the contactor.

The second probability function describes the chances of a microbiological species surviving following exposure to a disinfectant for a certain amount of time. This probability function is given by the modified Chick's equation: $(I/I_0) \approx 10^{-kCt}$. Each fraction of the flow would have a different "t" for which this equation would apply. For example, a virus that is exposed for 1 minute to $C=1$ mg/L ozone when $k=1$ L/mg-min has 0.1 (10 percent) chances to survive.

The following illustrates the intuitive origin of the SFA approach:

- The flow in an imaginary contactor may be viewed by flow lines.
- A microorganism that is introduced at time $t=0$ will follow one of these flow lines.
- For simplicity, consider that only four flow lines exist as represented on Figure 0-7.
- A microorganism that is introduced in the feed to the contactor has some probability (P_1) of following any one of these four lines.
- The microorganism will then remain for a specific detention time, characteristic of each flow line, in the contactor.
- This concept is presented schematically on Figure 0-7, where the flow lines are represented by four different tubes whose lengths (or detention times) correspond to the lengths of the flow lines on Figure 0-7.

- Microorganisms that are introduced into various tubes have different probabilities of survival (P2), because of different susceptibilities to disinfection in each of these tubes.
- The product of the probability that a microorganism will be carried into a specific tube (P1) times the probability of survival after being exposed to the hostile environment for the appropriate time (P2) is the probability that a microorganism introduced into the feed inlet will get out alive from a specific tube (P1)(P2).

For example, if 20 percent of the flow is directed into the first flowline and I/I_0 for this fraction of the flow equals 0.25, a microorganism has $(0.2)(0.25)$ or a 5 percent chance of emerging alive from this specific flowline. The total survival of microorganisms that are introduced into the inlet to the entire contactor can be computed by summing up all four survival probabilities (P1)(P2).

Complete examples for the application of the SFA are included in Section 0.2.8.3. For SFA to be applied, a high resolution tracer study must be available. The requirements for a high resolution tracer study are:

- Appropriate time distribution of sampling points.
- Limited degree of scatter in sample points.

The first requirement is to have several sample points prior to the occurrence of T_{10} and less frequent sampling points thereafter. Several sampling points prior to T_{10} are essential to get an accurate representation of what is occurring in the early flow through the contactor, when organisms are most likely to exit the contactor while still viable. The second requirement is for a limited degree of scatter between the sample points. The plotted curve should ideally be continuous to allow for more accurate integration to predict the survival of microorganisms.

0.2.7 Relative Inactivation of Giardia Cysts and Viruses

In most cases, when the CT required for the inactivation of Giardia cysts is greater than the CT required for the inactivation of viruses, compliance with the inactivation requirements for Giardia cysts will

A. FLOW LINES IN A CONTACTOR

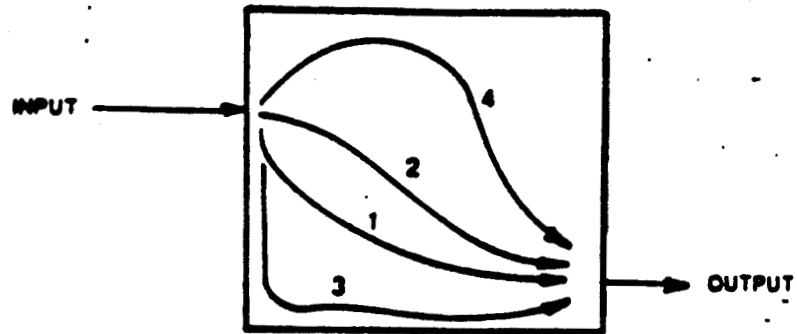

B. SCHEMATIC REPRESENTATION OF THE FLOW LINES

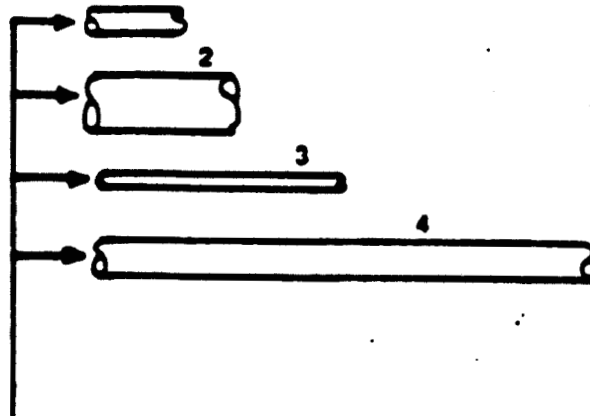

C. SURVIVAL PROBABILITY FOR AN ORGANISM

Flow Line	P_1 Fraction of Flow into the Flowline	P_2 (I/I_0) Survival Ratios	$P_1 P_2$ Overall Survival Ratios
1	2/10	1/4	16/320
2	4/10	1/8	16/320
3	1/10	1/16	2/320
4	3/10	1/32	2/320
SUM	1		37/320

FIGURE 0-7 - PRINCIPLE OF SEGREGATED FLOW ANALYSIS

assure compliance with the virus inactivation requirements. Specifically, this is true when:

$$k_{\text{virus}}/k_{\text{cyst}} > \log(I/I_0)_{\text{virus}} / \log(I/I_0)_{\text{cyst}} \quad (6)$$

The SWTR, however, requires a higher level of inactivation of viruses than Giardia cysts. Therefore, ozone contactors that are characterized by a high degree of turbulence will find that, as the flow configuration approaches that of a CSTR ($T_{10}/\text{HDT} < 1/3$), compliance with the virus inactivation requirements may be a more demanding task than meeting the inactivation requirements for Giardia cysts. Consequently, an ozone contactor that has a $T_{10}/\text{HDT} < 1/3$ and a low (I/I_0) should be checked for compliance with the inactivation of viruses as well as for cysts. Another way to understand this is that as the inactivation indicated by CT_{10} increases, the 10 percent of the water passing through the contactor with less contact time than T_{10} becomes more significant for lowering the overall inactivation efficiency for all the water passing through the contactor.

0.2.8 Examples of Determining Contact Time (T)

This section presents examples for the application of the three general approaches - T_{10} , SFA, and CSTR - for determining contact time.

0.2.8.1 Evaluation Using T_{10}

The following four examples illustrate when the T_{10} approach should be used and when alternate approaches are appropriate. Procedures for calculating the required ozone residual based on the T_{10} approach are outlined in the examples.

Example 0.2-4 Inactivation Required $> 2.5 \log$

The Haworth Water Treatment Plant, Hackensack, New Jersey, uses a turbine ozone chamber followed by a contact chamber to provide additional contact time. A schematic of the contactor is shown on Figure O-1. The treatment plant provides filtration after the ozone contactor. For the purposes of this example, although it is not the case for Hackensack, the

ozone system must provide disinfection for 2-log Giardia and 3-log virus inactivation to supplement filtration. The following conditions apply:

Water Temperature = 0.5 C
CT for 2-log Giardia = 1.9 mg-min/L
CT for 3-log virus = 1.4 mg-min/L

- A tracer study was conducted on one of the four ozone contactors. Figure 0-8 depicts the chart recorder of the raw data that were collected during the tracer study.
- The HDT at the flow rate of the study was 20 minutes, and the T_{10} occurs at 11 min.
- The T_{10}/HDT of 0.55, is greater than 1/3, making the T_{10} approach valid for this system.
- The CT for Giardia inactivation is the controlling CT because it is greater than the CT for virus inactivation.
- Using the T_{10} of 11 min, the residual needed to meet the CT requirement of 1.9 mg/L-min is determined as follows:

$$C = \frac{1.9 \text{ mg-min/L}}{11 \text{ min}} = 0.17 \text{ mg/L}$$

- As a result of using the T_{10} approach, the system must maintain an ozone concentration of 0.17 mg/L in the contactor to provide the necessary disinfection.

The application of the SFA method for this contactor is presented in Section 0.2.8.3.

Example 0.2-5 Low Detention Time, Inactivation Required <2.5-log

A system using slow sand filtration must provide disinfection for 1-log Giardia cyst and 2-log virus inactivation. The system has an ozone contactor equipped with a turbine mixer. The following conditions apply:

Water Temperature = 25 C
CT for 1-log Giardia = 0.16 mg-min/L
CT for 2-log virus = 0.15 mg-min/L

- The CT for Giardia cyst inactivation is greater than the CT for virus inactivation and is therefore the controlling CT.
- A tracer study was conducted for the ozone contactor and resulted in a T_{10} of 30 seconds.

- The HDT of the contactor at the flow rate of the study was 150 seconds.
- Thus $T_{10}/\text{HDT} = 30/150 = 0.2$, is less than $1/3$, however, because the required inactivation is less than 2.5-log, the T_{10} evaluation for this system is appropriate.
- Based on the T_{10} evaluation, the residual needed to meet the CT requirement is determined as follows:

$$\text{CT} = 0.16 \text{ mg-min/L}$$

$$C = \frac{0.16 \text{ mg-min/L}}{0.5 \text{ min}} = 0.32 \text{ mg/L}$$

- Thus, according to this approach, the system must provide an ozone concentration of 0.32 mg/L to meet the inactivation requirements.
- Because of the low T_{10}/HDT value for this system, the CSTR approach is an alternative for determining C. This example is presented in Section 0.2.8.2.

Example 0.2-6 Low Detention Time, Inactivation Required >2.5-log

An unfiltered water system must provide disinfection for a 4-log inactivation of viruses and a 3-log inactivation of Giardia cysts. The ozone system uses a single chamber turbine contactor for disinfection:

- The hydraulic detention time measured at peak flow rate is 30 minutes and T_{10} determined by a tracer study is 9 minutes.
- The T_{10} approach is not recommended for this system because T_{10}/HDT of 0.3 is less than $1/3$ and the required level of 4-log virus inactivation is higher than the 2.5-log level.
- SFA or the more conservative CSTR calculations may be used to determine the required ozone concentration for this system. Examples of the CSTR and SFA calculations are presented in Sections 0.2.8.2 and 0.2.8.3, respectively.

Example 0.2-7 High Detention Time, Inactivation Required <2.5-log

The Sturgeon Bay Water Treatment system (Rosenbeck, 1989) uses a series of two submerged turbine ozone contactors followed by a reactive chamber to disinfect ground water:

- The results of a tracer study conducted on one of the mixed contactors is shown on Figure 0-9.
- The T_{10} from this study is approximately 30 seconds while the hydraulic detention time is 62 seconds.

- $T_{10}/\text{HDT} = 30/62 = 0.48$ which is greater than $1/3$. Therefore, the T_{10} approach is appropriate for this system.

In this case, the SFA method is not recommended as an alternative to the T_{10} approach because of the minimal detention times in the contactor. With such a short period for the collection of samples, the data are insufficient for the SFA method. The resolution of the tracer studies, apparent in Figure O-9, will lead to an overly conservative estimate of the inactivation if differentiation is conducted by a forward algorithm.

0.2.8.2 Evaluations Using CSTR Calculations

The following two examples demonstrate the CSTR approach. One illustrates the benefit of the CSTR analysis over the T_{10} analysis. The other identifies conditions for which the CSTR approach is not practical.

Example 0.2-8 Low Detention Time, Inactivation Required <2.5-log

The system identified in Example 0.2-5 is a slow sand filtration plant, using ozone to provide for a 1-log Giardia cyst inactivation. Chlorine provides the 2-log virus inactivation. Because the level of inactivation required from ozone disinfection is less than <2.5-log, the system may choose any method for the determination of the contact time.

- A tracer study conducted on the ozone contactor resulted in a T_{10} of 30 sec for a HDT of 150 sec.
- The fraction of T_{10}/HDT is 0.2, which is less than $1/3$, indicating that the CSTR approach may be appropriate.
- Chlorine provides disinfection for the viruses, therefore the CSTR calculation for the ozone disinfection requirements will be based on Giardia cyst inactivation.
- The following conditions apply:

Water Temperature	=	25 C
CT for 1-log <u>Giardia</u> cyst	=	0.16 mg-min/L

- Equation 5 from Section 0.2.5 applies for the CSTR calculation:

$$C(\text{HDT}) = [1 - (I/I_0)] / [(2.303)k (I/I_0)]$$

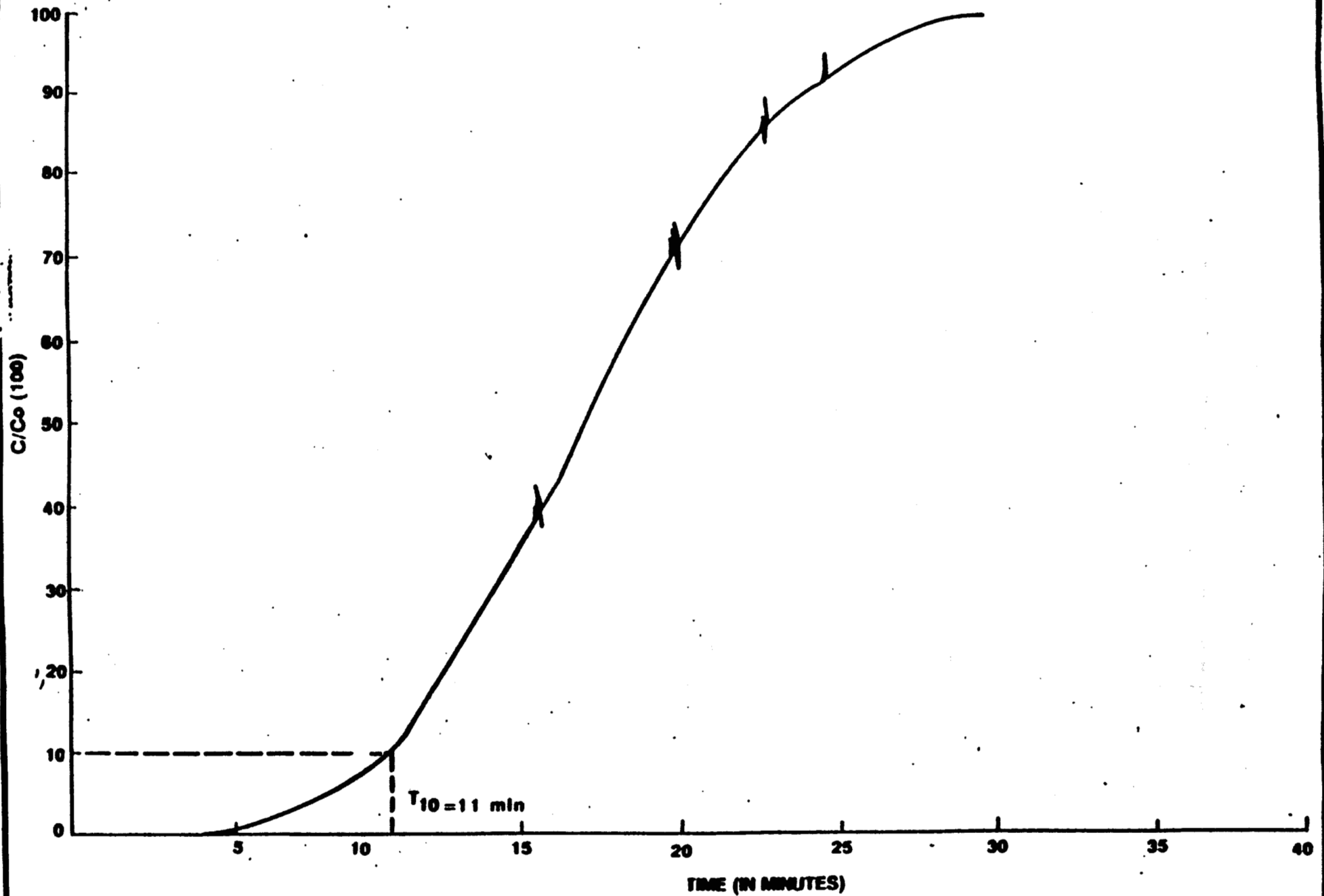

FIGURE 0-8- SEGREGATED FLOW ANALYSIS OF AN OZONE CONTACT CHAMBER-TRACER STUDY

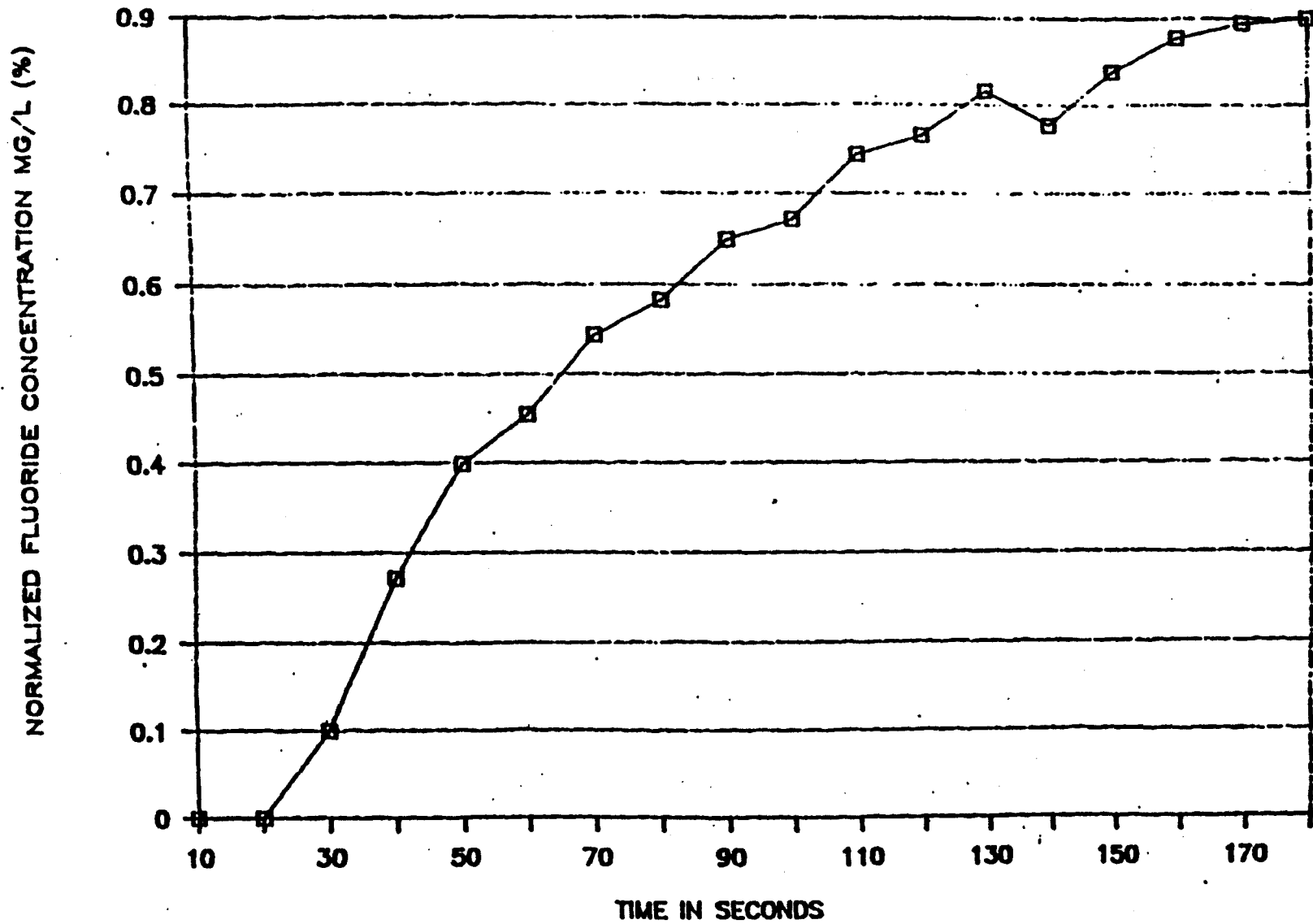

FIGURE 0-9 - TRACER STUDY OF STURGEON BAY OZONE CONTACTOR, G.L. ROSENBECK, (1989)

- The parameters are determined as follows:

1. From Table 0-3, $k_{\text{cysts}} = 6.25$ for $CT = 0.16$ min/L at 25°C
2. For 1-log inactivation, $I/I_0 = 0.1$
3. HDT = 150 sec or 2.5 min

- C is determined as follows:

$$C(\text{HDT}) = [0.9]/[(2.303)(6.25)(0.1)] = 0.625 \text{ mg-min/L}$$

$$C = 0.625/2.5 = 0.25 \text{ mg/L}$$

Thus, according to the CSTR approach, the system must provide an ozone concentration of 0.25 mg/L to meet the inactivation requirements. For this case, the system would prefer to use the CSTR approach rather than the T_{10} approach since the T_{10} approach would require a 0.32 mg/L ozone residual, as shown in Example 0.2-5.

Example 0.2-9 Low Detention Time, Inactivation Required >2.5-log

An unfiltered water system must provide disinfection for 4-log inactivation of viruses and 3-log inactivation of Giardia cysts. The system uses a single chamber turbine ozone contactor. Hydraulic detention time measured at peak flow rate is 30 minutes and T_{10} determined by tracer studies is 9 minutes. T_{10}/HDT is less than 1/3 and greater than 2.5-log inactivation is required, therefore the T_{10} approach should not be used. The CSTR or SFA methods are appropriate.

- The CSTR calculation must be conducted for both Giardia cysts and viruses to determine the controlling parameter
- Compute the C required for inactivation of Giardia cysts:
 - $k_{\text{cysts}} = 6.25$ (Table 0-3).
 - For 3-log inactivation, $I/I_0 = 0.001$
- Using the CSTR equation:

$$C(\text{HDT}) = [1-0.001]/[2.303(6.25)(0.001)] = 69.5 \text{ mg-min/L}$$

$$C = (69.5 \text{ mg-min/L})/(30 \text{ min}) = 2.3 \text{ mg/L}$$

- Compute the required C for inactivation of viruses:

- $k_{\text{virus}} = 13.3$ (Table 0-3)

- For 4-log inactivation $I/I_0 = 0.001$

- Applying the CSTR Equation:

$$C(\text{HDT}) = [1 - 0.0001]/[(2.303) (6.25) (0.0001)] = 326 \text{ mg-min/L}$$

$$C = (326 \text{ mg-min/L})/(30 \text{ min}) = 10.8 \text{ mg/L}$$

As indicated, virus inactivation is the controlling parameter, requiring a C of 10.8 mg/L. Because of the higher ozone residual needed for the virus inactivation, this example illustrates why systems should verify compliance with the inactivation requirements for viruses as well as for the inactivation requirements for Giardia cysts. Since obtaining an ozone residual of 10.8 mg/L is unrealistic, this example illustrates how stringent disinfection conditions can become assuming CSTR characteristics. Consequently, the SFA would result in a more feasible residual requirement for this system.

0.2.8.3 Evaluations Using SFA

The SFA method can be conducted on spread sheets. Table 0-4 presents the calculation procedure in spread sheet notations for a step tracer input:

- The first column of Table 0-4 represents the sequential numbering of consecutive tracer study measurements or digital measurement points fed into the computer.
- The second column represents the time interval that elapsed between the step change in tracer concentration and the sampling of the specific tracer point.
- The third column represents the tracer effluent concentration at a point in time determined by the analyzer (spectrophotometer conductivity meter, etc.) reading.
- The fourth column represents the tracer response on a scale of 0-1, where 0 corresponds to background reading of the analyzer and 1 to ultimate response after a long time interval. In other words, it is $C_{\text{out}}/C_{\text{in}}$ where C_{out} is the tracer concentration in the outlet of the contactor and C_{in} is the baseline tracer concentration in the inlet.

Seq. No.	time	height	$f(L)$	$l(L)$	10^{AC1}	$l_s(L)$	$l_s(L)$
1	t_1	h_1	$F_1 = h_1/h_n$	$l_1 = (l_2 - l_1)/(t_2 - t_1)$	10^{AC11}	$l_{s1} = F_1 10^{AC11}$	$l_{s1}(t_2 - t_1)$
2	t_2	h_2	$F_2 = h_2/h_n$	$l_2 = (F_3 - l_2)/(t_3 - t_2)$	10^{AC12}	$l_{s2} = F_2 10^{AC12}$	$l_{s2}(t_3 - t_2)$
i	t_i	h_i	$F_i = h_i/h_n$	$l_i = (l_{i+1} - l_i)/(t_{i+1} - t_i)$	10^{AC1i}	$l_{si} = F_i 10^{AC1i}$	$l_{si}(t_{i+1} - t_i)$
n	t_n	h_n	$F_n = 1$	$l_n = 0$	10^{AC1n}	$l_{sn} = 0$	$\frac{0}{(1/l_0 + \sum (E_s \Delta t))}$

TRACER CURVE FROM STEP INPUT

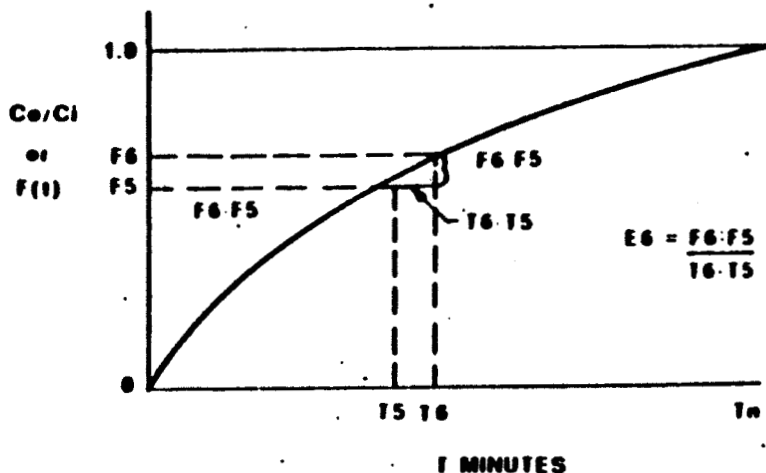

NOTE: GUIDANCE FOR CONDUCTING TRACER STUDIES IS GIVEN IN APPENDIX C

TABLE 0-4 - SPREAD SHEET NOTATIONS OF SEGREGATED FLOW ANALYSIS FOR A STEP TRACER

- The fifth column represents the forward derivative of the $F(t)$ response. It is the slope of the tracer curve at a specific time interval, or the rate at which C_{out}/C_{in} changes with respect to time at different intervals in time. Note that by forward evaluation of the derivative: $E(t) = [F(t+dt) - F(t)]/dt$ the $E(t)$ curve is shifted by half a dt toward the origin.
- This method of differentiation introduces an inherent safety margin to the calculation. Systems can reduce this safety margin by collecting more tracer points at the initial period of the tracer response, when the response is starting to increase.
- This period has the largest effect on the accuracy of the tracer analysis because most of the contribution to the total survival of microorganisms comes from the organisms that remain only for short time interval in the contactor.
- The sixth column represents Chick's inactivation rule, computed at the concentration and the appropriate 10^{-kct} .
- The seventh column represents the survival expectancy function ($E_s(t) = E(t)(10^{-kct})$) which is the product of columns 5 and 6.
- The eighth column represents the organism survival in each segment passing through the contactor. It is also known as the integral of the survival expectancy function (E_s presented in the 7th column).
- The survival ratio (I/I_0) is the sum of column 8. This represents the sum of organism survival in all the water segments passing through the contactor.
- Table 0-4 illustrates only one form of performing the integration (i.e., quadratic integration). Other integration methods can also be used.
- The corresponding log inactivation and the corresponding calculated CT may be computed by the procedures outlined in Section 0.2.4.

The following examples illustrate the use of the SFA method to calculate conditions in ozone contactors, and a situation where SFA cannot be used.

Example 0.2-10 Turbine Contactor

As noted in Example 0.2-4, the ozone system at Haworth Water Treatment Plant, uses a turbine ozone chamber followed by a reactive

chamber to provide additional contact time. A tracer study was conducted on one of the contactors resulting in a T_{10} value of 11 minutes for a HDT of 20 minutes. Using the same conditions as the above cited example, the SFA will be conducted on the tracer data. The following illustrates a step by step procedure for conducting a SFA:

- The digitized tracer response ($F(i)$) is depicted in Figure 0-10 as a function of $t(i)$ where:
 - i stands for the consecutive numbering of randomly chosen points from the tracer study chart, and
 - $t(i)$ is the corresponding time coordinate.
- The slope of the tracer curve, also known as the density of the expectancy function, $E(t)$ approximated by the following equation is depicted in Figure 0-10.

$$E(i) = [F(i+1)-F(i)]/[t(i+1)-t(i)]$$
- The digitized points were not translated into a smooth curve in order to avoid numeric compromises.
- The survival expectancy ($E_s(t)$) was then calculated by $E_s(i) = E_t(i)(10^{-k_{CT}(i)})$ and summed to give the survival ratio (I/I_0) as shown in Table 0-5.
- Figure 0-11 depicts the integration for conditions where the ozone residual is $C = 0.15$ mg/L.
- The cumulative survival ratio is 0.00982 which is below 0.01 assuring compliance with the 2-log or 99 percent inactivation requirement for Giardia cysts. A survival ratio of <0.01 corresponds to an inactivation of greater than 99 percent or 2-log.

The residual value determined from this method is lower than $C=0.17$ mg/L predicted by the T_{10} approach presented in Example 0.2-4. Although this example only shows a small difference in C values needed, other cases may result in a greater reduction of C compared to the C resulting from the T_{10} approach.

**SEGREGATED FLOW ANALYSIS
DIGITIZED TRACER RESPONSE, $F(t)$, $E(t)$**

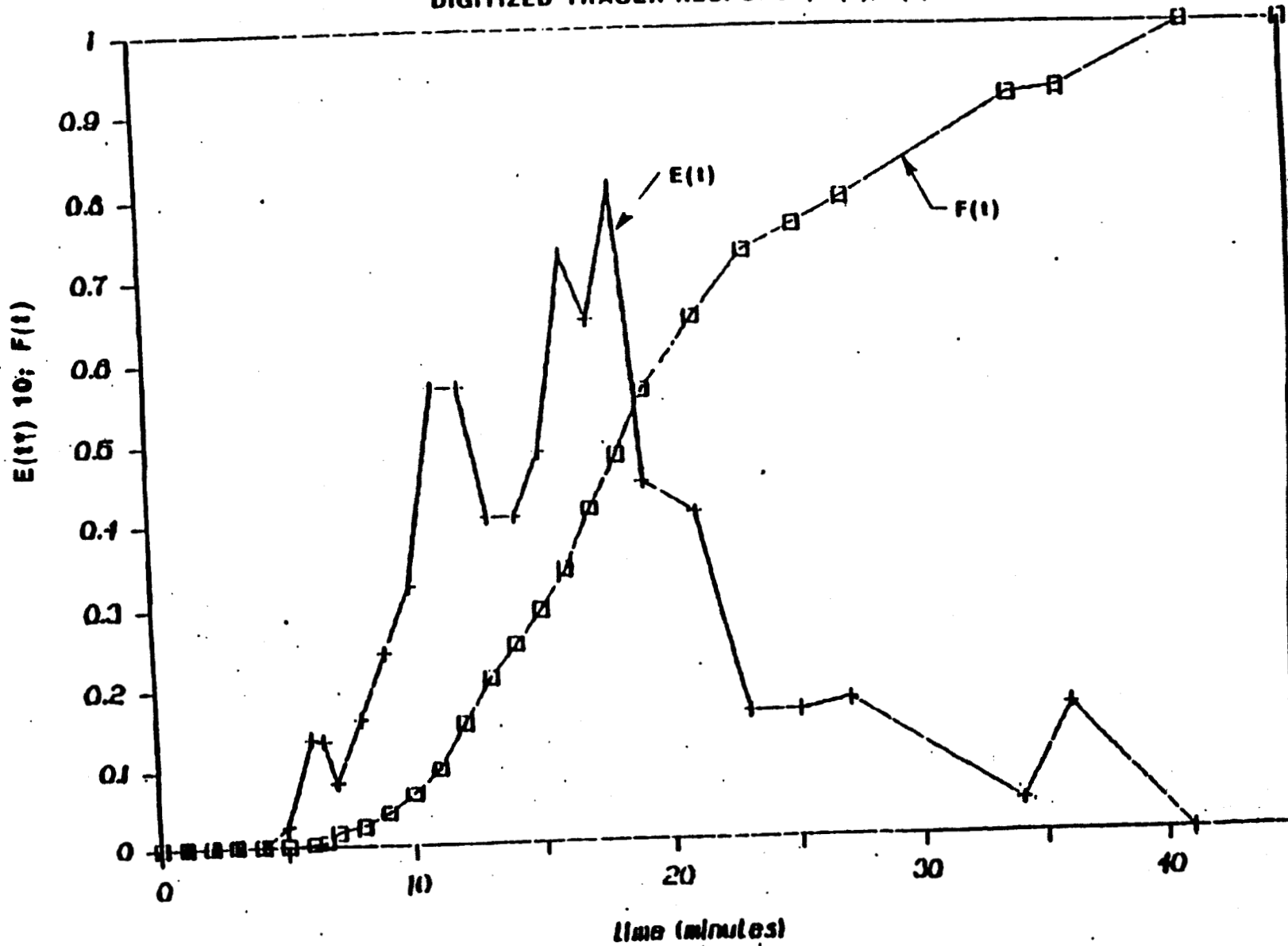

FIGURE 0-10- SEGREGATED FLOW ANALYSIS OF AN OZONE CONTACT CHAMBER- INTEGRATION OF SURVIVAL EFFICIENCY

TABLE 0-5

Segregated Flow Analysis
of an Ozone Disinfection Contactor at Hackensack

time (min)	height (mm)	F(t)	E(t)	10^{-kct} (C=0.16 k=1.03)	$E_s =$ $=E(t)10^{-kct}$	$(E_s)\Delta t$
0	0.0	0.000	0.000	1.000	0.00000	0.00000
1	0.0	0.000	0.000	0.708	0.00000	0.00000
2	0.0	0.000	0.000	0.502	0.00000	0.00000
3	0.0	0.000	0.000	0.355	0.00000	0.00000
4	0.0	0.000	0.000	0.252	0.00000	0.00000
5	0.0	0.000	0.002	0.178	0.00043	0.00013
6	0.3	0.002	0.014	0.126	0.00173	0.00035
6.5	0.5	0.004	0.013	0.106	0.00143	0.00215
7	2.0	0.016	0.008	0.089	0.00072	0.00072
8	3.0	0.024	0.016	0.063	0.00102	0.00204
9	5.0	0.040	0.024	0.045	0.00108	0.00324
10	8.0	0.065	0.032	0.032	0.00102	0.00408
11	12.0	0.097	0.056	0.022	0.00127	0.00889
12	19.0	0.153	0.056	0.016	0.00090	0.00630
13	26.0	0.210	0.040	0.011	0.00045	0.00225
14	31.0	0.250	0.040	0.008	0.00032	0.00160
15	36.0	0.290	0.048	0.006	0.00029	0.00174
16	42.0	0.339	0.073	0.004	0.00027	0.00243
17	51.0	0.411	0.065	0.003	0.00018	0.00144
18	59.0	0.476	0.081	0.002	0.00016	0.00160
19	69.0	0.556	0.044	0.001	0.00006	0.00066
21	80.0	0.645	0.040	0.001	0.00003	0.00030
23	90.0	0.726	0.016	0.000	0.00001	0.00004
25	94.0	0.758	0.016	0.000	0.00000	0.00000
27	98.0	0.790	0.017	0.000	0.00000	0.00000
34	113.0	0.911	0.004	0.000	0.00000	0.00000
36	114.0	0.919	0.016	0.000	0.00000	0.00000
41	124.0	1.000	0.000	0.000	0.00000	0.00000
45	124.0	1.0000	0.000	0.000	0.00000	0.00000

$$\Sigma(E_s)\Delta t + = I/I_0 = 0.00982$$

**SEGREGATED FLOW ANALYSIS
SURVIVAL OF CYSTS (C=0.15, k=1.03)**

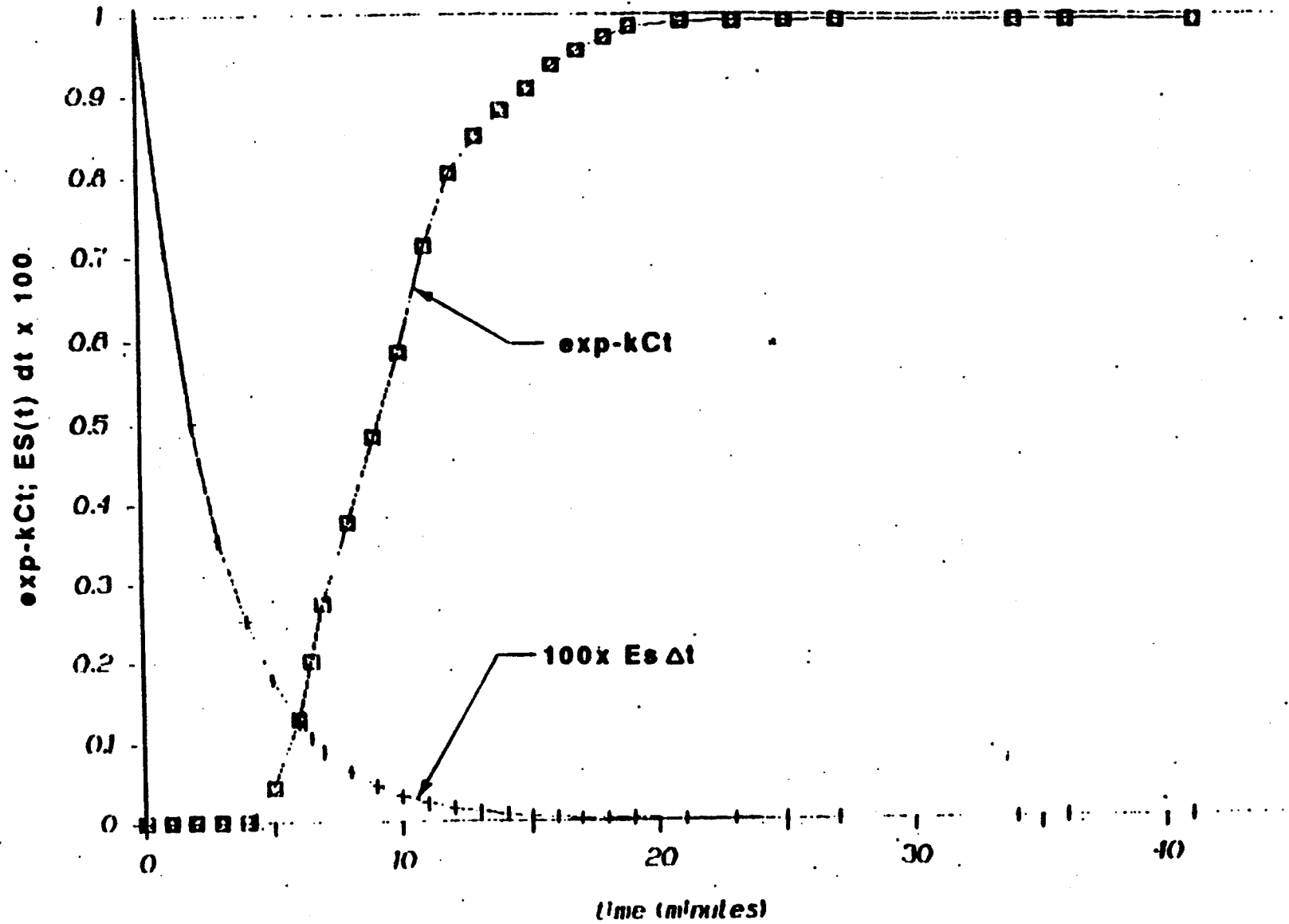

FIGURE 0-11 - SEGREGATED FLOW ANALYSIS OF OZONE CONTACT CHAMBER

0.2.9 ESTIMATING T

The results of this section are summarized in Figure 0-12. The decision tree shows the applicable methods of estimating T for each approach, and provides a quick means to compare alternatives and make a selection.

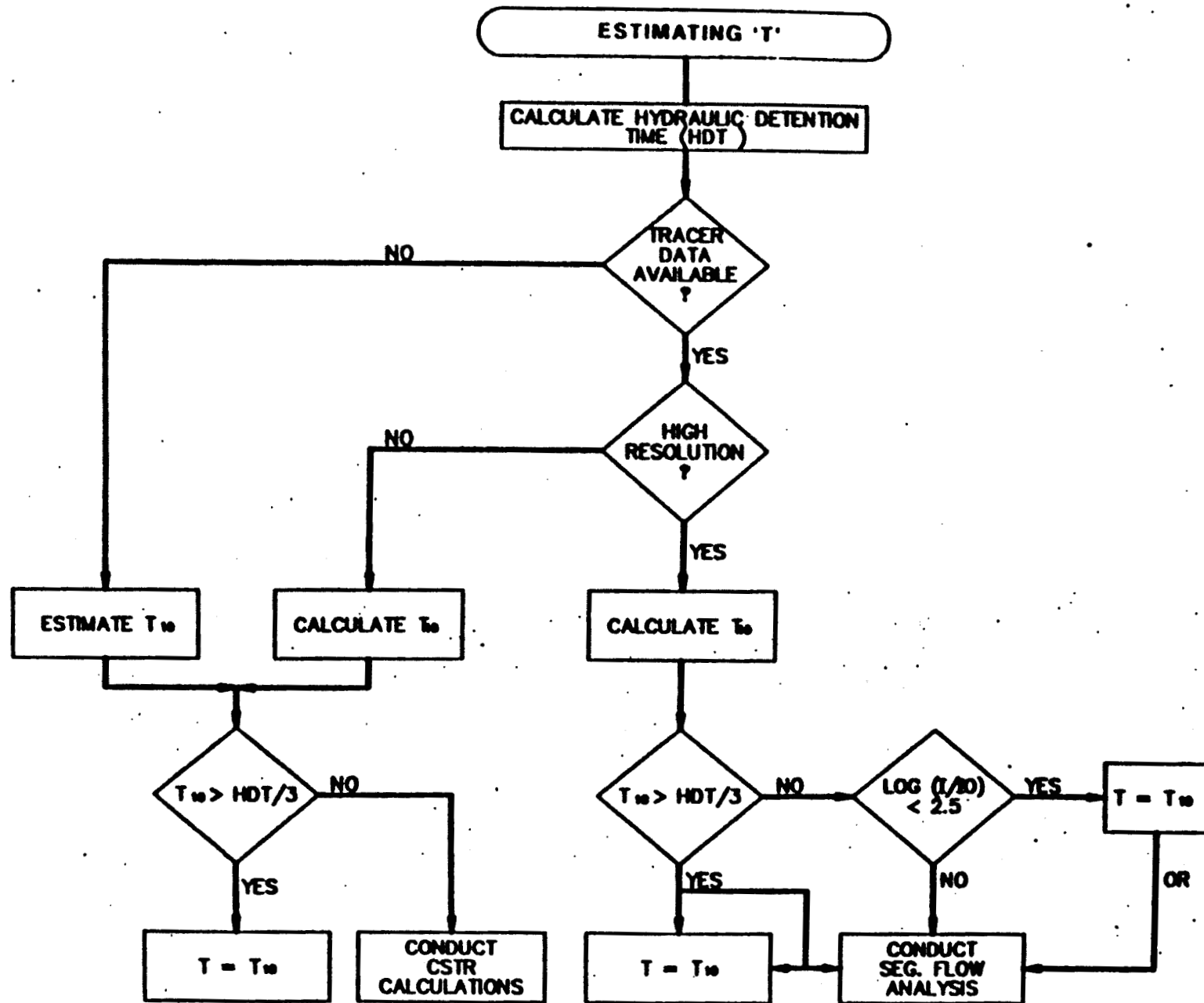

FIGURE 0-12 - DECISION TREE FOR ESTIMATING T

0.3 DETERMINATION OF OZONE CONCENTRATION (C)

0.3.1 Introduction

This section presents ways to measure or estimate the ozone concentration, C, for the calculation of CT. An alternative, more elaborate concept, requiring better characterization of the hydrodynamics of the ozone contactor is presented in Section 0.4 of this appendix.

EPA recommends use of the average dissolved ozone concentration in the water for C for all types of ozone contactors. The average concentration may be determined by one of following methods:

1. Direct measurement of the concentration profile of dissolved ozone in each contact chamber
2. Indirect prediction of the average concentration by assuming a set of conservative correlations between an observed variable such as the concentration of ozone in the outlet from the ozone chamber and the average concentration within the ozone chamber.

The application of these methods to estimate the average concentration should take into account the gas/liquid flow configuration in the ozone contactor. The next section presents a short discussion of the types of liquid/gas contact in ozone chambers, followed by two sections that describe the methods to estimate the average concentration in the chamber based on simple measurements.

Classification of Ozone Chambers

Ozone contactors currently in use or in design stage in the US may be classified into four types of flow configurations as illustrated on Figure 0-13. This, of course, does not preclude the use of other types of contactors. The four configurations are as follows:

1. Continuously Stirred-Tank Reactor (CSTR):

Ozone contactors using turbine agitators, where the water may be considered uniformly mixed as shown on Figure 0-13, diagram 1. Studies conducted in a full scale turbine contact chamber indicate that turbine contactors may be considered uniformly

mixed (Schwartz et al., 1990). This study was conducted in the first contact chamber under conditions of high ozone demand. Therefore, it is assumed that under less stringent kinetic conditions, turbine contactors can still be considered uniformly mixed.

2. Counter-Current Flow Chambers

In these chambers, the water flows opposite the direction of the gas bubbles. For example, the first and third chambers in the Los-Angeles ozone treatment system, as shown on Figure 0-2.

3. Co-Current Flow Chambers

In these chambers, the gas bubbles and the water flow in the same direction. For example, the Deep U-Tube contactor shown in Figure 0-5 and the Static Mixer contactor. This is the case also for the conventional gas/liquid contact chambers such as the second contact chamber in the configuration designed for the East Bay MUD water disinfection system, as shown on Figure 0-4.

4. Reactive Flow Chambers

In these chambers, no gas (and ozone) is being introduced into the chamber or conduit. The second and fourth chambers of the Los Angeles water disinfection system are reactive chambers (Figure 0-2).

0.3.2 Direct Measurement of C

Direct measurement of the dissolved ozone concentration is the preferred method to determine the ozone concentration in ozone contact chambers. However, very little full scale experience is currently available with this type of measurement. Some guidelines were developed based on the limited studies conducted at the Haworth, NJ (Schwartz et al. 1990) and Los Angeles water treatment systems (Stolarik and Christie, 1990). The guidelines developed for direct measurement of ozone concentration in the liquid phase are detailed in the following sections.

Analyze Each Chamber Separately

Every chamber of a multiple-chamber unit should be analyzed separately. Different chambers in series exhibit different ozone consumption rates and reactivities and, therefore, are likely to have different dissolved ozone profiles.

1. TURBINE CHAMBER

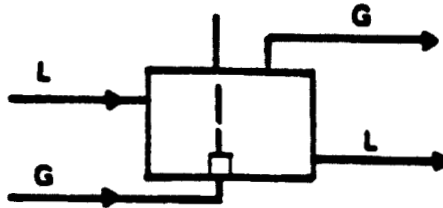

2. COUNTER-CURRENT CHAMBER

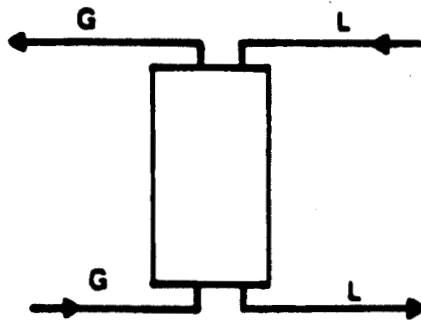

3. CO-CURRENT CHAMBER

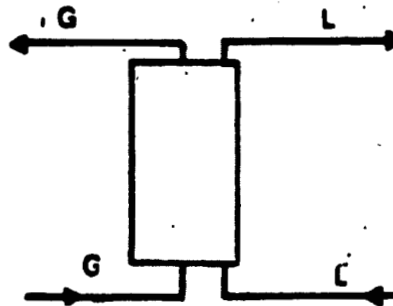

4. REACTIVE FLOW CHAMBER

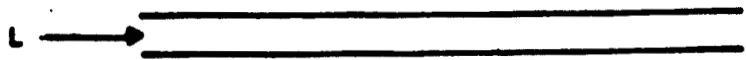

L: Liquid
G: Gas

FIGURE 0 13- FLOW CONFIGURATIONS IN OZONE CONTACTOR CHAMBERS

Avoid Interference From Gas Bubbles

Gas bubbles may strongly interfere with the measurement of ozone concentration, particularly if some bubbles are carried into the sampling taps. This interference may be reduced by directing the sampling port opposite to the direction of the bubble flow in order to prevent gas from entering the sampling tube. Additionally, the operator should verify, by visual inspection, that the sample water does not contain gas bubbles.

Systems using in-situ ozone analyzers should be careful to prevent direct contact of gas bubbles with the measuring probe which is usually a gas permeable membrane. Such contact may bias the measurements and give high results.

Minimize Distance to Ozone Analyzers

Minimize the distance from the sampling ports to the ozone analyzer to limit ozone consumption by reducing agents in the water. This consideration is particularly important when evaluating the concentration profile in chambers with high ozone demand such as the first chamber in multiple-chamber units.

Provide Proper Spacial Distribution

The vertical profile of the ozone concentration in ozone contact chambers should be measured in at least five vertical locations and at least two different horizontal locations for each vertical sampling point within the contact chamber. Each sample should represent the time averaged concentration at the specific location. This may be achieved by sampling a large volume of water into a container and analyzing the water by the indigo trisulfonate method (Bader and Hoigne, 1982). In-situ measurement of ozone should be carried out over a sufficient time interval to suppress temporal fluctuations. Such instruments should be initially calibrated by the indigo trisulfonate method. Facilities that have more than 25 percent deviation between the average concentration at two horizontal locations should collect additional measurements at a third location. The average of all measurements may be taken as the average concentration of dissolved ozone in the ozone contact chamber. For systems with a symmetrical vertical distribution of ozone concentration

the vertical sampling points should be equidistant. Systems with an asymmetrical distribution of available sampling points can perform an integration of the data to estimate the average concentration in the chamber. An example of this is given at the end of this section.

Some contact chambers, such as the Deep U-Tube chambers, static mixers and reactive flow chambers have a high length to width ratio, where the length of the chamber in the direction of fluid flow is greater than four times the cross section length. These chambers have more uniform radial concentration profiles, eliminating the need to measure the concentration at various vertical or horizontal locations. Therefore, measuring the concentration profile at several points along the flow path should be sufficient to accurately determine the average concentration.

Select Representative Locations

All sampling positions should be placed in representative locations, avoiding stagnant zones and zones near the wall. Measurements in stagnant locations will lead to low values of the average residual concentrations. While measurements at the wall may result in either an underestimate or overestimate of the residual depending on the ozone flow pattern.

Systems having two or more identical parallel ozone contact chambers may determine the average ozone concentration by measuring the concentration profile at one horizontal location in each contact chamber. These systems should, however, show by dual or triple horizontal measurements in at least one of the parallel chambers that the measurement in the particular horizontal location adequately represents the concentration profile in the contact chamber.

Example 0.3-1

A system with a co-current chamber with dimensions of 10' X 10' x 20' was sampled to determine the average concentration in the chamber. In accordance with the recommended guidelines, the following samples were taken:

Water Depth (ft)	Ozone Residual (mg/L)	
	H ₁	H ₂
2	0.1	0.12
6	0.15	0.17
10	0.15	0.14
14	0.3	0.25
18	0.6	0.65

- The horizontal sampling point measurements are within 25 percent of each other indicating that no additional horizontal sampling is needed. Figure 0-14a shows the sampling locations and the resulting ozone profile.
- Average the H₁ and H₂ sampling points to determine C_{avg}:
 $C_{avg} = (0.1 + 0.15 + 0.15 + 0.3 + 0.6 + 0.12 + 0.17 + 0.14 + 0.25 + 0.65)/10 = 0.26$. C_{avg} equals 0.26 mg/L, which is C for the chamber.

Example 0.3-2

A system with a co-current chamber and the same dimensions of the system in Example 0.3-1 has sampling results as follows:

Water Depth (ft)	Ozone Residual (mg/L)		
	H ₁	H ₂	Average ⁽¹⁾
2	0.1	0.12	0.11
8	0.16	0.14	0.15
14	0.27	0.3	0.285
16	0.70	0.73	0.715
18	0.62	0.61	0.615

⁽¹⁾ Average = $(H_1 + H_2)/2$

- The sampling points are not vertically equidistant so the system will plot the average ozone concentration of the horizontal sampling points versus depth to calculate the area under the curve. This approach should only be used if the sampling points cover the range of the water depth.
- As shown on Figure 0-14b, the area under the curve is determined for the range of depths sampled from 2 to 18 ft.
- Several methods can be used for calculating the area including:
 - Measurement with a planimeter
 - Mathematical methods such as:
 - Simson's Rule
 - Runge Kutta

SAMPLING LOCATIONS

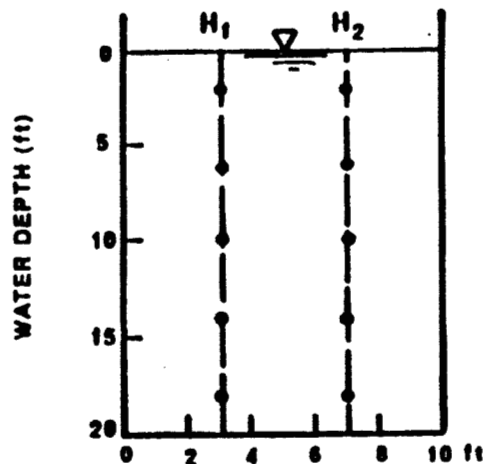

a. EQUIDISTANT SAMPLING

OZONE PROFILE

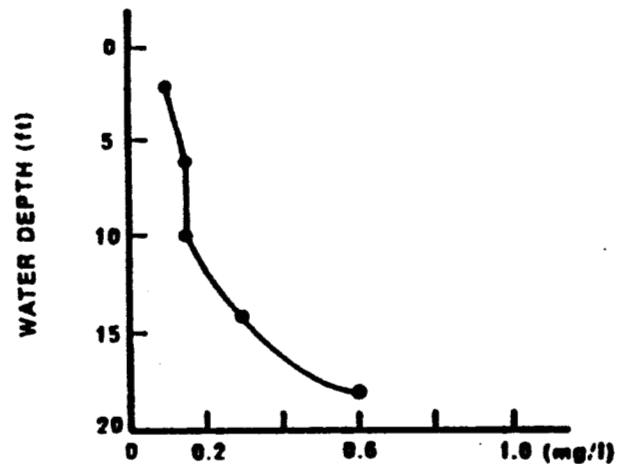

OZONE CONCENTRATION

SAMPLING LOCATIONS

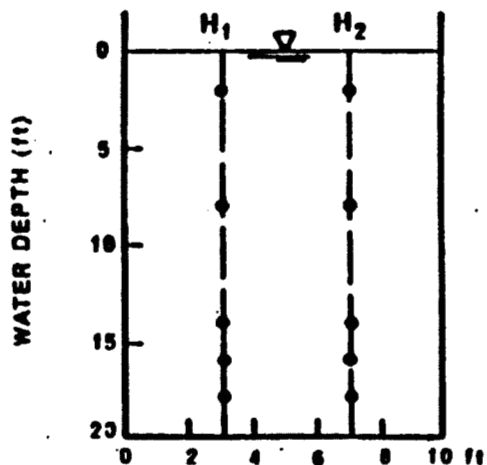

b. SKEWED SAMPLING

OZONE PROFILE

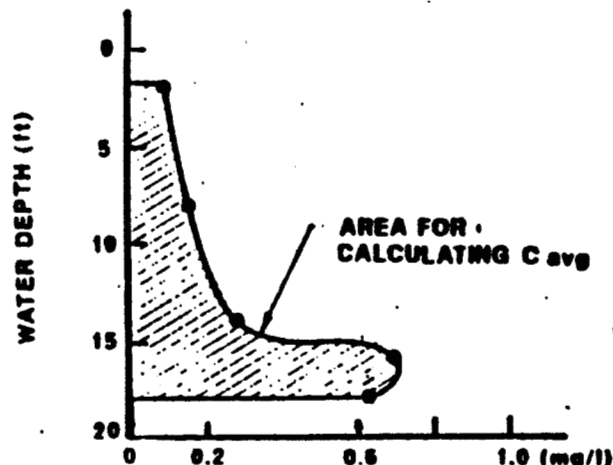

OZONE CONCENTRATION

FIGURE 0-14 - DIRECT MEASUREMENTS FOR DETERMINING C

- The area under the curve is in units of mg/L-ft. C_{avg} is determined as:

$$\frac{\text{area (mg/L-ft)}}{\text{range of depth sampled (ft)}}$$

- For this data, use of a planimeter results in an area of 5.44 mg/L-ft, with the concentration determined as follows:

$$\frac{5.44 \text{ mg/L} \cdot \text{ft}}{18 \text{ ft} - 2 \text{ ft}} = 0.34 \text{ mg/L}$$

0.3.3 Estimating C Based on Residual Measurements at the Outlet

For many systems, measuring ozone profiles in their ozone chamber may be impractical because of physical constraints. These systems may estimate C in the chamber based on measurements of the ozone residual at the outlet from the chamber. EPA has established correlations for different types of gas-liquid contact configurations currently in use in ozone contactors. These relationships were derived based on conservative assumptions regarding the type of flow configuration in the contactor. Due to the highly reactive nature of ozone the values for C vary slightly between first chambers and subsequent chambers. The recommended concentrations for first and subsequent chambers are summarized in Table 0-6.

0.3.3.1 First Chambers

A first chamber is the chamber in which ozone is initially introduced. In establishing guidelines for determining C values for the first ozone contact chamber, the following items were considered:

1. The relationship between C and the outlet concentration in the first chamber of a multiple-chamber system (or single chamber) may be very sensitive to the reaction order of the ozone consumption kinetics.

The average concentration in the contactor may be less than 10 percent of the outlet concentration. This was demonstrated in pilot plant studies conducted in a multiple chamber system by Stolarik and Christie, 1990. Therefore, general relationships between the residual ozone concentration at the outlet from a first (or single) ozone contact chamber and the average concentration in this chamber cannot be developed.

TABLE 0-6

CORRELATIONS TO PREDICT C BASED ON OUTLET OZONE CONCENTRATIONS^(1,3)

FLOW CONFIGURATION			
TURBINE	CO-CURRENT FLOW	COUNTER-CURRENT FLOW	REACTIVE FLOW
<u>First Chamber</u>			
C	PARTIAL ⁽²⁾ CREDIT	PARTIAL ⁽²⁾ CREDIT	NOT APPLICABLE
<u>Subsequent Chambers</u>			
$C = C_{out}$	$C = C_{out}$ OR $C = (C_{out} + C_{in})/2$	$C = C_{out}/2$	$C = C_{out}$

NOTES:

1. Definitions:

C Characteristic Concentration (mg/L)

C_{out} Dissolved ozone concentration at the outlet from the chamber (mg/L)

C_{in} Concentration of ozone at the inlet to the chamber (mg/L)

2. 1-log of virus inactivation providing that $C_{out} > 0.1$ mg/L and 1/2-log Giardia cysts inactivation providing that $C_{out} > 0.3$ mg/L.

3. Alternatively, C may equal the average concentration as evaluated by the direct measurement method (Section 0.3.2).

2. The rate of disinfection of viruses (coliphage) by ozone often decreases with respect to contact time whereby the initial inactivation rate is very fast and deteriorates afterwards.
3. Pilot plant experiments reported by Wolfe et al, (1989) suggest that the inactivation of organisms including MS2 bacteriophages, Giardia muris cysts, R2A bacteria and E. Coli, in the first chamber of a multiple-chamber reactor is very rapid even when high ozone demand waters are used.

Considering these items, EPA recommends a general guideline of crediting the first ozone chamber with CT credits equivalent to 1-log virus inactivation and 0.5-log Giardia cyst inactivation, provided that the residual concentration measured at the outlet from the first contact chamber exceeds 0.1 mg/L and 0.3 mg/L, respectively, regardless of the contactor configuration. However, this guideline does assume that the volume of the first chamber is equal to the volume of subsequent chambers. The credit for 1-log virus inactivation at an outlet residual of 0.1 mg/L may appear conservative with respect to MS2 bacteriophage data, however, only limited data for ozone inactivation of the animal viruses of concern is currently available. Preliminary test results indicate that bacteriophage may not be an appropriate indicator for virus inactivation by ozone (Finch, 1990).

Systems may prove higher performance of their first contact chambers by measuring the concentration profiles in the first chamber, as outlined in Section 0.3.2 or by applying the more sophisticated methods that are presented in Section 0.4.

0.3.3.2 Subsequent Chambers

The correlations in Table 0-6 are based on analysis of the dissolved concentration profile in liquid/gas contacting chambers. All correlations rely on the accurate measurement of ozone concentration outside of the gas/liquid contacting regime. Concentrations at the outlet from the ozone contact chambers can be measured accurately without interferences from the ozone bubbles. The correlations represent the highest possible estimate of C that can be supported without site-specific test data. These estimates are conservative and systems may choose to determine C based on

direct measurement of the concentration profile in the contact chamber, or use one of the procedures recommended in Section 0.4.

Correlations were developed for the four types of flow configurations:

- Turbine
- Counter Current Flow
- Co-current Flow
- Reactive Flow

Turbine

For turbine chambers or rigorously mixed chambers, the flow characteristics in the chamber approach that of a CSTR and, therefore, the concentration at the outlet from the contactor (C_{out}) is assumed to be representative of the dissolved concentration of ozone in the liquid phase (C). Currently, contactors using turbine agitators appear to approximate CSTR characteristics (Schwartz et al, 1990). Other systems with T_{10}/HDT values less than 0.33 may use the same correlations. This correlation is applicable to every chamber, including turbine contactors used for first chambers or as a single chamber contactor.

The measurement of ozone concentration in the gas phase is a possible alternative for determining C although such correlations will be highly site specific. A procedure to develop site specific correlations between the average ozone concentration and the off-gas concentration is presented in Section 0.4.2.1.

Counter-Current Flow

In counter-current flow, the water flows opposite to the direction of bubble rise. Measurement of the concentration profile in such systems revealed that the concentration in the liquid phase uniformly increased with depth in the ozone chamber as shown in Figure 0-15. The maximum concentration in the chamber is achieved near the water outlet from the ozone chamber.

Measurement of the ozone concentration in an ideal plug flow chamber reveals that the average concentration is only 25 to 50 percent of the outlet concentration for these chambers under typical operating conditions. Additional contributions to the average concentration that are not accounted for by the plug flow analysis, include the contribution of

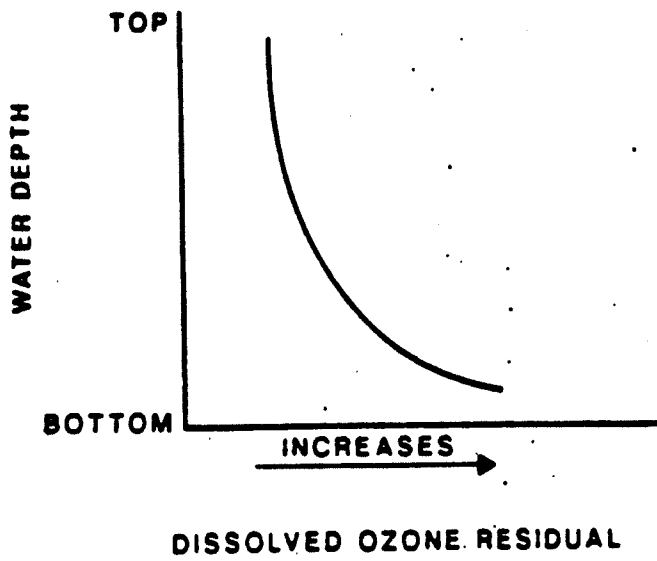

A. COUNTER-CURRENT FLOW PROFILE

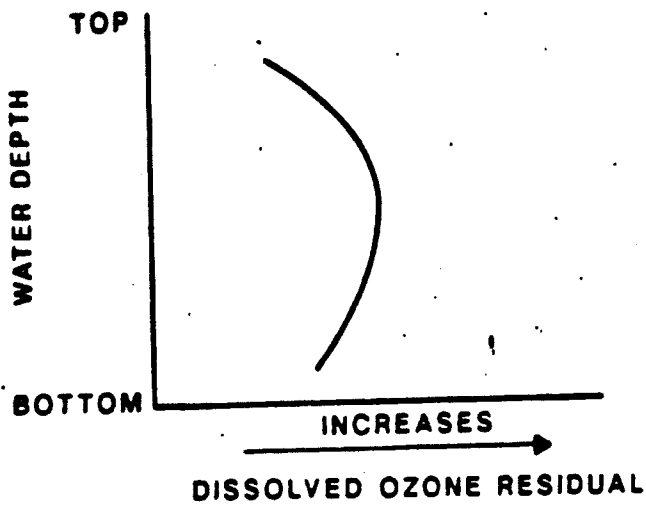

B. CO-CURRENT FLOW PROFILE

FIGURE 0-15 - OZONE CONCENTRATION PROFILES

turbulence and the contribution of the inlet concentration. Based on these considerations, EPA recommends the use of one-half the outlet concentration of ozone as an estimate for C.

The measurement of ozone concentration in the off gas is a possible alternative for determining the average ozone concentration although the correlations will be highly site specific. A procedure to develop site specific correlations between the average ozone concentration and the off-gas concentration is presented in Section 0.4.2.1.

Co-Current Flow

In co-current flow, both the water and gas flow in the same direction. The ozone concentration profile in co-current operation increases until it reaches a maximum and then decreases along the contact chamber as shown on Figure 0-15. The dissolved ozone concentration increases at the beginning of the column due to dominant mass transfer from the ozone rich bubbles. Then the gas phase becomes depleted of ozone and the impact of ozone consumption in the liquid phase dominates the ozone profile. C can be estimated as the concentration of dissolved ozone at the outlet or by the average of the inlet and outlet concentrations of dissolved ozone, whichever is higher. This estimate should still be conservative, particularly for systems exhibiting high transfer efficiencies.

The measurement of ozone concentration in the off gas is a possible alternative for determining the average ozone concentration although the correlations will be highly site specific. A procedure to develop site specific correlations between the average ozone concentration and the off-gas concentration is presented in Section 0.4.2.1.

Reactive Flow

In ozone chambers operated in a reactive flow configuration, the water contains dissolved ozone residual from previous chambers but no additional ozone is being introduced. Reactive flow chambers are used: for other disinfectants, such as chlorine, chlorine dioxide and chloramines; for the decay of ozone following a contactor or a static mixer; and for combining ozone with hydrogen peroxide.

For static mixers, the mixer acts as a turbine chamber with the pipeline following the mixer acting as the reactive chamber. The pipeline is in effect the second chamber and the guidelines in Table 0-6 apply for the determination of C. The contact time in the pipeline can be calculated by assuming plug flow.

In order to be consistent with the recommendations for monitoring other disinfectants in reactive flow chambers, and, in order to assure compliance under worst case conditions, the use of the residual outlet from the chamber (C_{out}) is recommended as a conservative measure of C. The CT for reactive flow chambers may be estimated by dividing the chamber into subunits, measuring the concentration at the end of each subunit, and adding the CT credits.

Estimates of C based on the outlet concentration were conservatively developed based on available test data. EPA's recommended values for C are summarized in Table 0-6. A system may choose to perform additional testing for direct measurement of ozone residuals to support a higher value, if appropriate. In addition, a reactive flow chamber may be subdivided into smaller units with ozone measurements at the end of each unit to improve CT credit.

0.3.4 Estimating C

The results of this section are summarized in Figure 0-16. The decision tree shows the applicable methods of estimating C for each flow configuration, and provides a quick means to compare alternatives and make a selection.

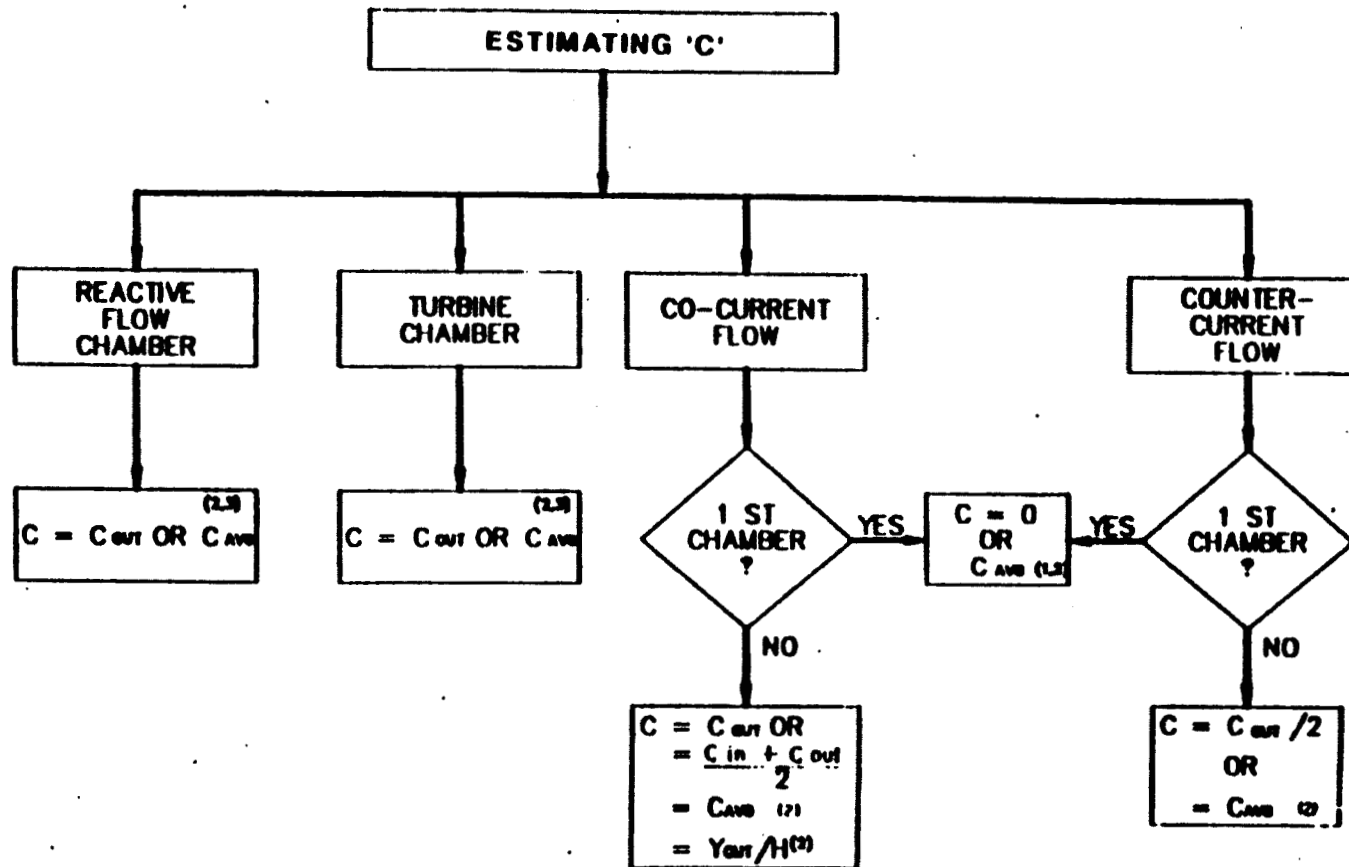

NOTES: 1. CREDIT FOR 1-log VIRUS WHEN $C_{out} > 0.1 \text{ mg/L}$
 AND 0.5 -log GIARDIA INACTIVATION
 WHEN $C_{out} > 0.3 \text{ mg/L}$ FOR FIRST CHAMBERS.

2. DETERMINATION OF C_{AVG} IN SECTION 0.3.2 AND Y_{OUT}/H IN SECTION 0.4.2
3. FOR FIRST OR SUBSEQUENT CHAMBERS.

FIGURE 0-16- DECISION TREE FOR ESTIMATING C

0.4 SITE-SPECIFIC EVALUATION OF OZONE CONTACTORS

0.4.1 Introduction

The second set of guidelines is designed to prevent systems from costly over-design and use of overdoses of ozone, by performing site specific characterization of their ozone contactors. This approach was partially utilized in the previous two sections by recommending a direct measurement of the ozone concentration profile and by allowing systems to use the SFA or CSTR approaches. In this section the site specific evaluation procedure will be further developed by presenting additional options to improve disinfection credits or simplify monitoring procedures. EPA recommends the following three alternatives for site specific evaluations:

- Estimating C by measurement of another variable
- Modeling performance of field scale operation
- Use of microbial indicator studies

C may be estimated by measuring an easily monitored (observable) variable. Systems should develop site specific correlations between C and another observable parameter such as the gas or liquid concentration exiting (C_{out}) the chamber and monitor this observable parameter instead of C. Guidelines to develop such site specific correlations are presented in Section 0.4.2

Modelling the performance of full scale operations is an alternative to the separate C and T approach. The first procedure separated the analysis into two separate issues related to determining C and T. Extensive modelling of the system may predict higher inactivation levels, even for the same C and T. EPA recommends that systems construct mathematical models of their ozone contactors to predict the disinfection performance, provided that the models are confirmed by experimental observation of the actual ozone concentration profile in the contact chambers, as discussed in Section 0.4.3.

Microbial indicator studies may be used to determine the inactivation of viruses and Giardia cysts in ozone contactors. EPA recommends that systems be allowed to evaluate the performance of their disinfection systems by spiking a pilot of the contactor with an indicator microorganism and predicting the actual inactivation of Giardia cysts and viruses

based on the inactivation of the indicator microorganisms. Guidelines to conduct such pilot scale performance evaluations are presented in Section 0.4.4.

0.4.2 Site Specific Correlation of C with an Observable Variable

Section 0.3 recommends determining the concentration of ozone in contactors by one of the following ways:

1. Measure the concentration profile in the chambers and determine the average dissolved ozone concentration for C.
2. Measure the dissolved concentration of ozone in the water outlet from each chamber (C_{out}) and estimate C by the correlations presented in Tables 0-6.

This section presents an alternative method to determine C.

The SWTR requires unfiltered systems to report a daily CT for their disinfection systems. Similar requirements may be specified by the Primacy Agency for filtered systems. Measuring the concentration in the ozone chambers each day may be difficult. Determining the ozone concentration in a chamber by continuous or daily measurements of other variables is probably preferable. Likewise, many systems may prefer to monitor the ozone concentration in the off gas (Y_{out}) or via the applied ozone dose rather than monitor C_{out} . However, based on available data, a non-site specific correlation between the average ozone concentration in the chamber and an observable variable other than C_{out} could not be developed.

EPA encourages systems to develop such site specific correlations and use them instead of the general procedures. These correlations may be developed in one of the following ways:

1. Determine site specific correlations between C_{out} and another variable that can be easily monitored. Measure the variable, estimate C_{out} and then use the correlations presented in Tables 0-6 to predict C.
2. Determine site specific correlations directly between C and another variable such as the ozone concentration in the off gas (Y_{out}) or C_{out} . Measure that variable and estimate C.

Correlations between C or C_{out} and a measurable parameter may vary in complexity from a simple empirical linear correlation to a highly sophisticated mathematical model accounting for the ozone concentration profile in the contact chamber. Development of appropriate correlations depends on the engineering capabilities of the utility. Therefore, EPA does not recommend any particular mathematical relationships. However, the following sections present guidelines to assist systems in developing appropriate correlations.

Correlations for Specific Chambers

The correlations should refer to a specific contact chamber and should be verified to fit the performance of this chamber. For example, a correlation for the first chamber should not be used to predict C in the second chamber of a multiple-chamber system.

Developing the Correlation

When fitting the correlation with experimental data, a record of the following variables should be kept:

- a. Water flow rate
- b. Gas flow rate
- c. Ozone concentration in the gas feed
- d. Ozone transfer efficiency
- d. Water temperature and pH
- e. Concentrations of all major inorganic reducing agents, if they constitute a substantial proportion of the total ozone demand, such as iron(II) and manganese, TOC, alkalinity and turbidity.
- f. C_{out} or whatever is being correlated
- g. The measurable variables such as ozone dosage or C_{out}

The system should also record the dependent (C or C_{out}) and independent measurable variables.

Application of the Correlation

The correlation should be evaluated with at least a 90 percent confidence level. Since confidence margins are very sensitive to the number of observations used to develop the relationship, this requirement will prevent the use of correlations that are based on a limited amount of observations. On the other hand, because systems usually make daily records of most of the parameters needed to develop a correlation, the number of observations will usually be very high, thereby, providing a high confidence level for the correlation. Simple procedures to determine confidence intervals are presented in statistical textbooks.

The correlation must be checked periodically, such as monthly, as an additional precaution against unexpected shifts in water conditions.

The correlation should be applied only to conditions that are within the parametric range for which the correlation was developed, as noted in the second guideline. Interpolation is permitted but extrapolation is not. Correlations developed during the winter time should not be used to evaluate performance in the summer.

EPA believes that by permitting such correlations, systems will be encouraged to apply sophisticated mathematical models in order to decrease the confidence interval and administer smaller doses of ozone. EPA also expects that systems will develop correlations between C in the contactors and measurable parameters to simplify their operations. Small or lesser equipped systems will then be able to use these relationships to estimate the performance of their ozone contactors. EPA intends to follow advances in this field and issue updated examples and guidelines regarding the selection of efficient site specific correlations.

0.4.2.1 Utilizing Off-Gas Measurements

In ozone contactors, the gas and liquid streams equilibrate when the contact between the gas and liquid is intimate enough and for sufficient time, otherwise the concentration in the water phase will be much lower than the equilibrium concentration. It can be assumed that close to equilibrium conditions are reached, when the transfer efficiency in the contactors is greater than 85 percent ($(Y_{in} - Y_{out})/Y_{in} > 0.85$). When the transfer efficiency is greater than 85 percent, systems may use solubility

constant data to calculate C_{out} from the contactor, based on the ozone concentration in the off gas. This may lead to a slight over estimate of the concentration in the liquid phase but this over estimate is justified, in view of the better reliability of gas phase measurements.

Henry's constants for ozone at various temperatures are presented in Table O-7. The residual concentration of ozone may be estimated by:

$$C_{out} = Y_{out}/H$$

Where:

Y_{out} = The concentration of ozone in the gas phase (ppm - volume or partial pressure-atm)

C_{out} = The concentration of ozone in the liquid phase (mg/L)

H = Henry's constant (atm/mg/L)

When applying off-gas modelling, liquid phase measurements must be made periodically to check the correlation, as the ozone transfer efficiency has a high impact on the results of this correlation.

Systems must be cautioned against the use of off-gas measurements for multiple chamber contactors with a common headspace. As noted previously, modelling must be specific to individual chambers. Thus, if a contactor has a common head space between chambers, no distinction can be made as to the concentration in each chamber. Therefore, off-gas measurements for modelling are recommended for use with single chamber contactors.

Example 0.4-1

The Metropolitan Water District of Southern California conducted off-gas monitoring on a single chamber co-current flow pilot contactor to determine the dissolved ozone concentration:

- Operating conditions were as follows:
 - source water: Colorado River
 - feed gas ozone concentration = 2 percent by weight
 - off gas ozone concentration = 0.185 percent by weight (or 0.123 percent by volume)

- transfer efficiency = 90.8 percent
- temperature = 16.5 C
- observed ozone residual = 1.04 mg/L
- Henry's constant 16.5°C = 0.001179 atm/mg/L
- The ozone residual estimated from the off gas concentration is:

$$C_{out} = Y_{out}/H = 0.00123/0.001179 = 1.04 \text{ mg/L}$$
- The measured residual is the same as that predicted by the off-gas measurement indicating that this approach is appropriate for this system.

Example 0.4-2 Empirical Correlation between C_{out} and Y_{out}

A system using two counter-current contact chambers in series wants to predict C_{out} in the second chamber by the concentration of ozone in the off-gas (Y_{out}). Daily observations of the pertinent parameters during the first month of operation are presented in Table 0-8.

- The system chose to correlate C_{out} and Y_{out} by linear empirical correlation.
- The daily observations, and the best linear fit are presented in Figure 0-17.
- The 90 percent confidence interval is presented by the lower line in Figure 0-17.
- The system may use the 90 percent confidence level line to estimate C_{out} based on measurements of Y_{out} .
- For example when $Y_{out} = 0.4$ percent then the system may use $C_{out} = 0.36$ mg/L.
- Although the best estimate is $C_{out} = 0.4$ mg/L, the system should predict $C_{out} = 0.36$ mg/L.
- Now, according to Table 0-6, the system may predict C using the recommended guideline of $C = C_{out}/2 = (0.36)/2 = 0.18$ mg/L.
- The system measures the ozone concentration at the chamber outlet monthly, to check the model correlation.

TABLE 0-7

HENRY'S CONSTANTS FOR OZONE⁽¹⁾

<u>Water Temperature (°C)</u>	<u>Henry's Constant atm/Mole Fraction</u>	<u>Henry's Constant (atm/mg/l ozone)</u>
0	1,940	0.00073
5	2,180	0.00082
10	2,480	0.00093
15	2,880	0.00108
20	3,760	0.00141
25	4,570	0.00171
30	5,980	0.00224

NOTE: ⁽¹⁾ EPA, 1986

TABLE 0-8

Empirical Correlation
Between C_{out} and Y_{out}

Y_{out}	C_{out}	COD	Temp. °C	Y_{in} %
0.5	0.5	2.0	20	2.0
0.47	0.43	2.8	15	2.0
0.38	0.41	2.5	17	2.0
0.39	0.4	2.3	18	2.0
0.28	0.32	2.4	18	2.0
0.2	0.17	2.6	20	2.0
0.25	0.23	2.0	20	2.0
0.32	0.27	2.0	21	1.9
0.29	0.27	2.0	18	1.9
0.2	0.18	2.0	17	2.0
0.22	0.2	1.9	18	2.1
0.30	0.33	1.8	20	2.0
0.32	0.34	1.9	17	2.0
0.28	0.27	1.9	18	1.8
0.29	0.32	2.5	18	1.9
0.4	0.42	2.4	19	1.9
0.47	0.45	2.3	19	1.8
0.35	0.37	2.4	21	1.9
0.30	0.29	1.9	19	1.8
0.20	0.17	1.9	19	1.8
0.15	1.19	2.0	19	2.0
0.12	0.20	1.9	17	2.0
0.17	0.17	1.9	19	1.9
0.14	0.16	2.0	19	2.0
0.13	0.12	1.9	18	2.0
0.25	0.27	1.9	17	2.0
0.29	0.32	1.9	18	2.1
0.30	0.29	1.8	17	2.0
0.22	0.20	1.9	17	2.0
0.22	0.20	1.9	18	1.9

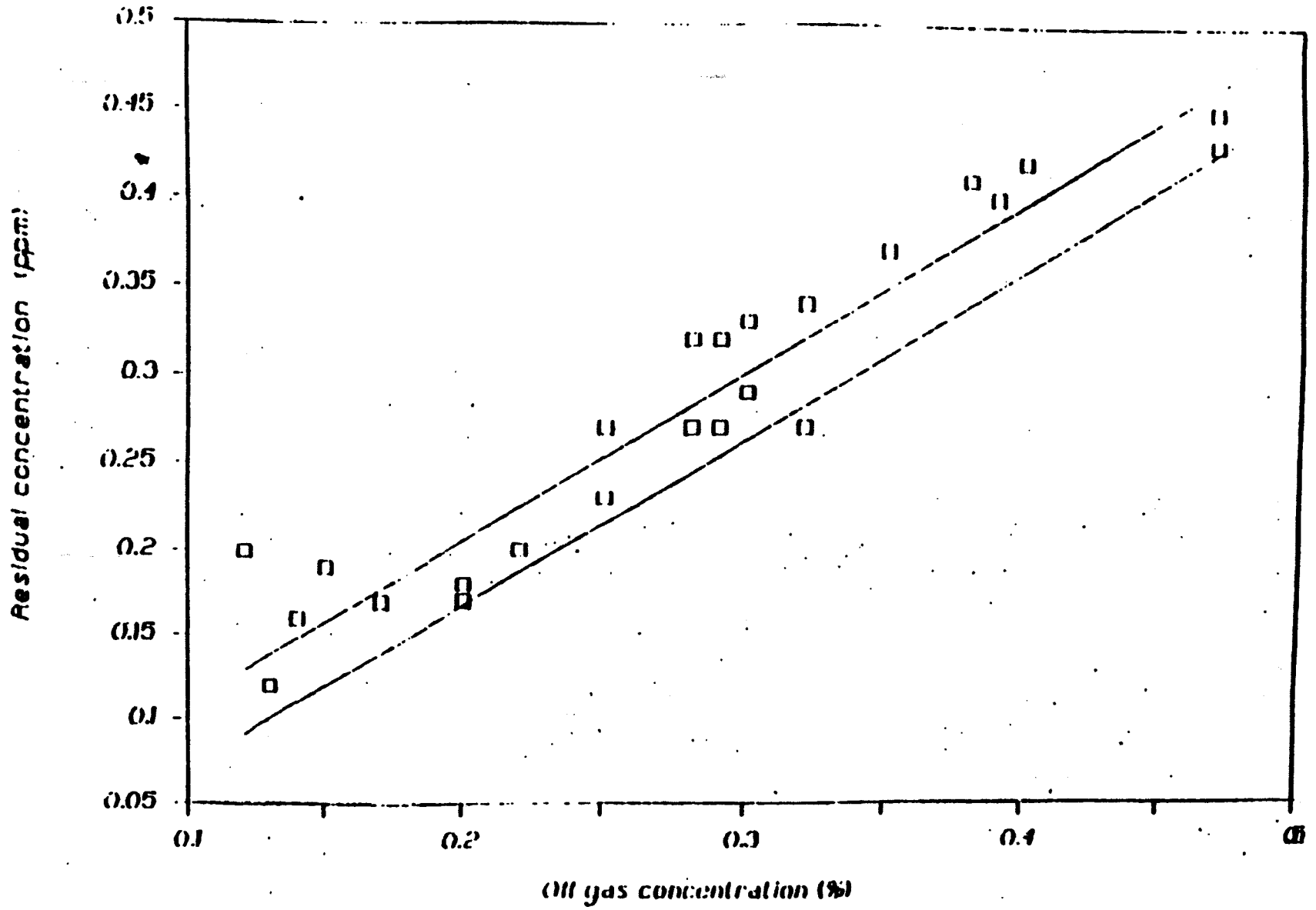

FIGURE 0-17 - EXAMPLE OF EMPIRICAL CORRELATION OF RESIDUAL OZONE AND OFF GAS

- If this system had the means to monitor the concentration profile in the contactor and determine C directly it could develop a correlation between C and Y_{out} instead of using Table O-6.

0.4.3 Modeling the Performance of Full Scale Operations

More extensive site specific mathematical modelling of the actual performance of the ozone contactor may determine higher inactivation levels than those determined by the separate C and T approach. Therefore, systems should be allowed to use such advanced modelling, provided that these models are confirmed by direct measurement of the dissolved ozone profile in the contactor. Only after the model is confirmed to correctly estimate the concentration profile in the contactor can it be used to estimate the inactivation performance of the contactor. Systems with multiple chamber contactors must develop models for each of the chambers.

Various types of mathematical models for reaction-diffusion systems were reported (Danckwerts, 1976) and some were shown to be applicable for ozone contactors (Guroi and Singer, 1982). This section deliberately avoids giving preference to any type of mathematical modelling in order to encourage engineering innovations. The guidelines presented below may help systems to select appropriate modelling that will be consistent with the requirements of the SWTR.

The model should account for the ozone demand of the water being treated in the contactor. The rate of ozone reaction and decomposition should be based on batch experiments, on-site pilot plant columns, or full-scale measurements.

The model should represent the actual flow distribution in the ozone contact chambers by incorporating a dispersion term and/or a three dimensional velocity distribution term in the contactor.

The modelled profile of the concentration of dissolved ozone in the contactor should fit the actual distribution of dissolved ozone, as verified by direct measurements, with a variation of less than 10 to 20 percent. This difference between the model and measured residual allows for the inherent inaccuracies in measuring the actual ozone residual. The mathematically modelled concentration profile should not be used without comparing it with actual measurements. Even elaborate mathematical models

are not considered reliable enough to estimate the concentration distributions of dissolved gasses in complex gas/liquid operations, without additional verification of the actual concentration profile in the contactor.

In addition to the above guidelines, the model may also account for other phenomena that may affect the performance of the ozone contact chambers, such as: the effects of varying bubble diameter during its movement through the contactor, the effect of stagnant regions in the contactor and the variation of the hydrostatic pressure.

For example, a system may use the two film theory coupled with reaction kinetics to estimate the performance of an ozone contact chamber. Using the two film theory the relevant differential equations are:

$$L \frac{dC}{dz} = M_t + M_r + M_d$$

$$G \frac{dy}{dz} = M_t$$

$$L \frac{dI}{dz} = M_d - KCI$$

Where:

C = Concentration of dissolved ozone (mg/L)

G = Gas flow rate per cross section of the contactor ($m^2 \cdot Kg$ gas/min)

I = Concentration of the target microorganism (Giardia or viruses)

L = Water flow rate per cross section area of the reactor (Kg water/min. m^2)

y = Concentration of ozone in the gas phase (mg/L)

z = Length coordinate of the contactor

M_t = An expression for ozone transfer from the bubble phase to the water phase. For example, $k_1 a (C_1 - C)$ where $k_1 a$ stands for the volumetric mass transfer coefficient, C_1 represents the interfacial concentration of ozone, given by solubility data (Table O-10).

M_r = An expression for the rate of ozone consumption in the water due to auto-decomposition and the ozone demand of the treated water. For example, $M_r = k_1 C - k_2 (C)(R)$. Where k_1 and k_2 are kinetic coefficients, and R represents the variable ozone demand, such as TOC. An additional equation may be required to represent the variation of R along the contactor.

Md = An expression for the dispersion by turbulence and bubble flow of dissolved ozone in the specific contactor. For example, Dd^2C/dz^2 the dispersion coefficient (D) may be evaluated by analysis of tracer study data. The third equation describing the microorganism concentration (dI/dz) should incorporate the same dispersion coefficient (D).

KCI = Chick's inactivation term ($K=2.303k$, where k = Chick-Watson's inactivation coefficient presented in Table O-4, C represents the local concentration of ozone and I represents the concentration of microorganisms).

The validity of these equations is subject to the appropriate boundary conditions at the bottom and top of the contactor. The signs of the various terms depend on the definition of coordinates and the type of flow configuration (co-current or counter-current flow configuration).

0.4.4 Microbial Indicator Studies to Model Inactivation Contactors

According to the recommendations in Appendix G, systems may demonstrate the actual performance of a disinfection system rather than rely on the CT approach. The procedures outlined in Appendix G recommend the use of Giardia muris cysts as indicators of Giardia inactivation and bacteriophage (MS2) as indicators for virus inactivation by disinfection in general. However, recent data indicate that MS2 phages may be substantially more sensitive to ozone disinfection than pathogenic viruses, and therefore are not a good indicator for determining adequate ozonation conditions for inactivating pathogenic viruses (Finch, 1990). Additional research is needed to determine which coliphage species, if any, can be used as an appropriate indicator for virus inactivation by ozone. Pilot scale inactivation experiments using appropriate indicator microorganisms can serve as powerful tools to indicate the performance of the ozone contactors. This section contains guidelines for conducting indicator studies. At this time, full-scale testing with indicator organisms is not feasible because of the high volume of organisms needed and the concern for introducing organisms into the finished water. However, with the development of naturally occurring indicators such as resistant species of coliphage, demonstration on the full-scale level may be feasible in the future.

Systems may determine the performance of their disinfection basins by demonstrating levels of inactivation of indicator microorganisms such as Giardia muris cysts, or other indicator microorganisms provided that such demonstrations are based on solid engineering principles. The following steps can be used for conducting indicator studies:

1. Batch Experiments

On-site batch disinfection experiments are recommended with treated water spiked with indicator microorganisms to determine the inactivation kinetics of the indicator used in the pilot scale experiments. Microorganisms should be used as indicators preferably in the range where the inactivation kinetics approximate Chick's law. This protocol assumes that within the desired inactivation range, the inactivation kinetics will approximate Chick's law. It is important to note that other disinfection kinetic models, not yet apparent, may be developed to more accurately predict ozone inactivation efficiency than the Chick-Watson model. Evidence that other models may be more appropriate is shown with data generated by several researchers for different organisms (Wolfe, R.L. et al, 1989; Finch G., et al 1988; Finch G. and Smith, D.W. 1989).

2. Pilot Scale Indicator Experiments

Pilot-scale experiments should then be conducted using identical strains of biological indicators to those used in the batch experiments. The pilot-scale experiments should be repeated under identical gas and water flow conditions with and without introducing ozone into the gas stream. The actual performance may then be calculated by subtracting the inactivation achieved in the control experiment (without ozone) from the inactivation achieved in the ozone disinfection experiments.

3. Evaluation of Inactivation Performances

Systems may choose direct or indirect methods to interpret the inactivation performance of ozone contactors based on indicator studies. The direct method is more conservative and simple while the indirect method is more accurate but requires mathematical modelling of the contactors. The two procedures are outlined below:

1. Direct prediction of inactivation performance

- a. Determine k_i (where k_i is Chick-Watson's inactivation coefficient of the indicator microorganism) from batch test data with the expression:

$$\log(I/I_0)_{\text{indicator}} = -k_i Ct$$

where:

$(I/I_0)_{\text{indicator}}$ as = Survival ratio of indicator microorganism determined by batch experiments.

C = Dissolved ozone concentration in the batch experiment (mg/L)

t = time (minutes) elapsed from the beginning of the batch experiment

Note: This assumes that the inactivation data will provide a reasonable fit for this equation. If this is not true, then the following is not applicable and other relationships should be developed.

- b. Determine the disinfection performance of the pilot scale disinfection system on the indicator microorganism $(I/I_0)_{\text{indicator}}$.

- c. Calculate the inactivation of Giardia cysts or viruses (I/I_0) using the appropriate k' values from Table O-3:

$$\log(I/I_0) = \log(I/I_0)_{\text{indicator}} (k'/k_i) \theta \quad (k_i > k) \quad (7)$$

$$\log(I/I_0) = \log(I/I_0)_{\text{indicator}} \quad (k_i < k) \quad (8)$$

This equation still represents an approximation because it neglects dispersion effects. The laws used in deriving the above equations are based on conservative similarity approaches. When the indicator microorganism is less resistant to ozone disinfection than the target organism ($k_i > k$), then the plug flow operation represents the more conservative prediction approach. Equation 7 is based on the assumption that the flow configuration in the chamber approaches plug flow. When the indicator microorganism is more vulnerable than the target microorganism ($k_i < k$) then the CSTR approach provides a more conservative estimate. Equation 4 represents a conservative approximation to the CSTR similarity

rule. A more accurate determination of the inactivation performance of the contactor may be calculated by the following approach:

2. Indirect determination of the disinfection performance

- a. Determine k_i (where k_i is Chick-Watson's inactivation coefficient of the indicator microorganism) from batch test data with the expression:

$$\log(I/I_0)_{\text{indicator}} = -k_i Ct$$

where:

$(I/I_0)_{\text{indicator}}$ = Survival ratio of indicator micro-organisms as determined by batch experiments.

C = Dissolved ozone concentration in the batch experiment (mg/L)

t = time (minutes) elapsed from the beginning of the batch experiment

- b. Determine the disinfection performance of the pilot scale inactivation level of the indicator microorganism $(I/I_0)_{\text{indicator}}$.
- c. Determine the actual concentration profile in the disinfection chamber (see Section 0.3.2).
- d. Construct a mathematical model that estimates the concentration profile in the contactor as discussed in Section 0.4.3
- e. Confirm the mathematical model by fitting its parameters such as dispersion or kinetic coefficients to describe accurately the concentration profile of ozone in the contactor and the overall inactivation of the indicator microorganism. A model that predicts within 10-20 percent the inactivation of the indicator microorganism and the concentration profile of dissolved ozone in the contactor would be considered to be valid and can be used by incorporating k values from Table 0-3 to estimate the inactivation of Giardia cysts or viruses in the contactor.

REFERENCES

Bader, H. and J. Hoigne, Determination of Ozone in Water by the Indigo Method, A Submitted Standard Method, Ozone: Science and Engineering, pp 449-456, 1982, 4

Carns, K, Design of East Bay Municipal Utility District ozone disinfection plants in Oakland Ca., presented at EPA workshop on Ozone CT, Cincinnati, OH., Feb. 1990

Chick, H., An investigation of the laws of disinfection, J. Hygiene, 8, 92 (1908)

Danckwerts, P.V. Gas Liquid Reactions, McGraw Hill Inc. (1976)

Finch, G.R., Smith, D.W., Stiles, M.E., Dose Response of Escherichia Coli in Ozone Demand-free Phosphate Buffer, Water Research Vol. 22, No.12, pp. 1563-1570, 1988.

Finch, G., University of Alberta, Canada, Private Communication (1990).

Hoff, J. C., Strengths and weaknesses of using CT values to evaluate disinfection practice, in assurance of adequate disinfection, or C-T or not C-T, AWWA seminar proceedings, Annual AWWA Conference, Kansas City, pp. 9 (1987)

Guroi M.D. and P.C. Singer, Kinetics of ozone decomposition, A dynamic approach, Env. Sci. & Tech., 16, 377 (1982)

Joost, R.D., L.A. Jackson and L.J. Bollyky, Optimization of ozone contactors for drinking water disinfection, Proceedings of the 9th Ozone World Congress, L.J. Bollyky, Editor, New York, NY, vol 1, pp. 551 (1989).

Lev, O. and S. Regli, Compliance of ozone disinfection systems with the Surface Water Treatment Rule, Selection of characteristic exposure time (T), submitted to J. of Env. Eng. ASCE (1990a)

Lev, O. and S. Regli, Compliance of ozone disinfection systems with the Surface Water Treatment Rule, Selection of characteristic concentration (C), submitted to J. of Env. Eng. ASCE (1990b)

Levenspiel, O., Chemical Reaction Engineering, 2nd ed. Wiley, New York, NY (1972).

Perry R.H., Perry's Chemical Engineering Handbook, McGraw Hill Book Company, New York, NY (1963)

Richards, D. A. and Fleischman, M., Ozone transfer to aqueous systems in a static mixer, 2nd Symposium on ozone technology, Montreal, Canada, R. G. Rice, P. Pichet and M. A. Vincent, eds, p. 57 (1975).

Rice, R. EPA, in preparation, Source Document: Ozone Treatment of Drinking Water, EPA/625/1-86/021.

Rosenbeck, G.L, McMahon Associates, Inc., Private communication (1989)

Schwartz, B., Hackensack Water Company, Private communication (1989)

Schwartz, B., L.C. Fung and C. N. Weng, Determination of ozone concentration in turbine contactor, presented at EPA Workshop on Ozone CT, Cincinnati, OH., Feb. 1990

Seinfeld J. H. and Lapidus L., Mathematical methods in Chemical Engineering, Vol. 3, Process Modeling Estimation and Identification, Prentice Hall Inc. (1984).

Stolarik, G.L. and J. D. Christie, Projection of ozone C-T values, Los Angeles Aqueduct Filtration Plant, presented at Int. Ozone Assoc. Conf. Monroe, Mich., April 1987.

Stolarik, G.L. and J. D. Christie, Projection of ozone C-T values, Los Angeles Aqueduct Filtration Plant, presented at EPA workshop on Ozone CT, Cincinnati, OH., Feb. 1990

Treybal, R.E., Mass-transfer operations, McGraw-Hill Book Company, 3rd ed. (1980)

Watson, H.E., A note on the variation of the rate of disinfection with change in the concentration of the disinfectant, J. Hygiene, 8, 536 (1908)

Wolfe, R.L, M.H. Stewart, K.N. Scott and M. J. McGuire, Inactivation of Giardia Muris and indicator organisms seeded in surface water supplies by peroxone and ozone, Env. Sci. and Tech., 23, 744 (1989)

Yuteri C. and Gurol M.D. Evaluation of kinetic parameters for the ozonation of organic micropollutants, Wat. Sci. & Tech. 21, 465 (1989)

Printed on Recycled Paper