

# Naval Base Kitsap at Bangor Test Pile Program

## **Final** Marine Mammal Monitoring Report

**BANGOR, WASHINGTON**



**April 2012**

**HDR**

## Suggested Citation

---

HDR Inc. 2012. Naval Base Kitsap at Bangor Test Pile Program, Bangor, Washington. Final Marine Mammal Monitoring Report. Prepared for Naval Facilities Engineering Northwest, Silverdale, WA. April 2012.

## Table of Contents

---

<b>ACRONYMS AND ABBREVIATIONS.....</b>	<b>iv</b>
<b>SECTION 1 INTRODUCTION.....</b>	<b>1</b>
<b>SECTION 2 METHODS.....</b>	<b>2</b>
<b>SECTION 3 RESULTS.....</b>	<b>25</b>
<b>SECTION 4 RECOMMENDATIONS.....</b>	<b>80</b>
<b>SECTION 5 ACKNOWLEDGEMENTS.....</b>	<b>81</b>
<b>SECTION 6 LIST OF PREPARERS.....</b>	<b>81</b>
<b>SECTION 7 REFERENCES.....</b>	<b>82</b>

## Appendices

---

- A. U.S. Navy Test Pile Program in Hood Canal, Final Marine Mammal Monitoring Plan**
- B. Baseline Survey Data**
- C. Environmental, Oceanographic, and Sighting Conditions**
- D. Example Data Sheet**
- E. Sighting Codes**
- F. Air Bubble Curtain Underwater Sound Mitigation System**
- G. Underwater and Airborne Marine Mammal Takes for the TPP for All Vibratory and Impact Driving Events**
- H. All Sightings During Pile Driving and Non-Pile Driving Activities**
- I. Photos of Project Area**

## Figures

---

Figure 1. Vicinity Map .....	3
Figure 2. Project Area.....	4
Figure 3. Line Transect Design for Baseline Surveys in Hood Canal .....	7
Figure 4. Line Transect Design for Baseline Surveys in Dabob Bay .....	8
Figure 5. Modeled, Monitored, and Actual Level B Harassment Zones .....	14
Figure 6. All Steller sea lion sightings. Points may represent more than one individual. ....	15
Figure 7. Phase 1 Boat Locations Relative to Monitored and Actual Level B (Behavioral Disturbance) Harassment Zones .....	17
Figure 8. Phase 2 Boat Locations Relative to the Monitored and Actual Level B (Behavioral Disturbance) Harassment Zones .....	18
Figure 9. Mean Number of Animals per Sighting (Phases 1 and 2).....	43
Figure 10. Mean Number of Animals per Sighting (Phase 1).....	44
Figure 11. Mean Number of Animals per Sighting (Phase 2).....	45
Figure 12. All California sea lion sightings. Points may represent more than one individual. ....	47
Figure 13. Harbor seal sightings during vibratory pile driving. Points may represent more than one individual. ....	48
Figure 14. All harbor seal sightings during impact pile driving. Points may represent more than one individual. ....	49
Figure 15. California sea lion sightings during vibratory and impact pile driving. Points may represent more than one individual. ....	50
Figure 16. All harbor porpoise sightings. Points may represent more than one individual. ....	59
Figure 17. Harbor porpoise sightings during vibratory and impact pile driving. Points may represent more than one individual. ....	61
Figure 18. Sightings of Other Marine Species During Pile Driving.....	67
Figure 19a. Number of Sightings by Sea State Condition .....	68
Figure 19b. Number of Sightings by Weather Condition .....	69
Figure 20. Cetacean Behaviors (Percent of Total) Observed during TPP .....	69
Figure 21. Pinniped Behaviors (Percent of Total) Observed during TPP .....	70
Figure 22. Cetacean Behaviors Observed Before, During, and After Pile Driving.....	74
Figure 23. Pinniped Behaviors Observed Before, During, and After Pile Driving Activities .....	75
Figure 24. Cetacean Behavior by Construction Type.....	76
Figure 25. Pinniped Behaviors by Construction Type.....	78



## Tables

---

Table 1. Project Staff.....	5
Table 2. Summary of Phase I Construction Monitoring Efforts for the TPP Pile Driving Project .....	10
Table 3. Summary of Phase I Baseline Survey Efforts for the TPP Pile Driving Project.....	11
Table 4. Summary of Phase II Construction Monitoring Efforts for the TPP Pile Driving Project .....	11
Table 5. Summary of Phase II Baseline Survey Efforts for the TPP Pile Driving Project .....	12
Table 6. Pile Specifications.....	24
Table 7. Acoustic Results from Impact Pile Driving.....	26
Table 8. Distances to RMS Sound Level Thresholds From Impact Pile Driving .....	30
Table 9. Summary of Sound Levels During Vibratory Pile Installation and Removal.....	33
Table 10. Modeled and Measured Marine Mammal Behavioral Harassment RMS Sound Level Thresholds for Impact (160 dB) and Vibratory (120 dB) Pile Driving.....	37
Table 11. Summary of Airborne Sound Levels During Impact Driving .....	38
Table 12. Summary of Airborne Sound Levels During Vibratory Driving .....	40
Table 13. Total Number of Animals and Sightings by Species (Phases 1 & 2).....	43
Table 14. Total Number of Animals and Sightings by Species (Phase 1).....	44
Table 15. Total Number of Animals and Sightings by Species (Phase 2).....	45
Table 16. Number of Animals and Sightings by Species During Pile Installation/Removal Activities (Phases 1 and 2).....	51
Table 17. Number of Animals and Sightings by Species During Pile Installation/Removal Activities (Phase 1).....	51
Table 18. Number of Animals and Sightings by Species During Pile Installation/Removal Activities (Phase 2).....	52
Table 19. Summary of Underwater and Airborne Marine Mammal Takes During the TPP .....	52
Table 20. Distances to 120 dB RMS Sound Level Threshold from Vibratory Pile Driving.....	54
Table 21. Missed Takes in the Unmonitored Area of the Behavioral Harassment Zone.....	56
Table 22. Marine Mammal Mitigation Events During the TPP .....	56
Table 23. All Harbor Porpoise Sightings During 30 Minute Pre-Watch, Pile Driving Activity, and 30 Minute Post-Watch Time Periods.....	60
Table 24. All Steller Sea Lion Sightings .....	62
Table 25. Other Sightings of Marine Species, by Number of Animals and Sightings, Observed During Pile Driving (Phases 1 and 2) .....	58
Table 26. Comparison of Cetacean Behaviors Observed During Pile Driving Activities Among Distances From Piles during the TPP.....	71
Table 27. Pinniped Behaviors Observed During Pile Driving Activities by Distance From Pile <sup>1</sup> .....	71
Table 28. Cetacean Behaviors Observed During Construction Versus Non-Construction Periods .....	72
Table 29. Pinniped Behaviors Observed During Construction Versus Non-Construction Periods.....	72
Table 30. Cetacean Behaviors Observed Before, During, and After Pile Driving Activities .....	73
Table 31. Pinniped Behaviors Observed Before, During, and After Pile Driving Activities.....	74
Table 32. Cetacean Behaviors by Construction Type.....	76
Table 33. Percent and Number of Pinniped Behaviors Observed by Construction Type .....	77

## Acronyms and Abbreviations

---

cfm	cubic feet per minute
cm	centimeter
dB	decibel(s)
dB re 1 $\mu$ Pa	dB referenced to 1 micropascal
DON	Department of the Navy
EHW	Explosives Handling Wharf
EZ	Exclusion Zone
ESA	Endangered Species Act
ft	feet
GPS	Global Positioning System
ICMP	Integrated Comprehensive Monitoring Program
IHA	Incidental Harassment Authorization
km	kilometers
km <sup>2</sup>	square kilometers
lb(s)	pounds(s)
m	meters
m <sup>3</sup>	cubic meters
min	minutes(s)
MMO	Marine Mammal Observer
MMPA	Marine Mammal Protection Act
NBK	Naval Base Kitsap at Bangor
NMFS	National Marine Fisheries Service
nm	nautical miles
nm <sup>2</sup>	square nautical miles
RMS	root mean square
SLM	Sound-level Meters
SPL	Sound Pressure Level
TPP	Test Pile Program
USCG	United States Coast Guard
USFWS	United States Fish and Wildlife Service
WRA	Water Restricted Area
ZOI	Zones of Influence

## Section 1 Introduction

---

This report summarizes the marine mammal monitoring effort implemented for the Test Pile Program (TPP) which occurred between 29 August – 20 October 2011 at Naval Base Kitsap (NBK) at Bangor. The purpose of the Test Pile Program was to acquire accurate geotechnical and sound propagation data to validate design concepts, construction methods, and environmental analyses for the proposed Explosives Handling Wharf (EHW-2) and for future projects at the waterfront at NBK. The program included hydroacoustic monitoring to evaluate noise attenuation techniques and to determine the distance(s) at which sound pressure levels (both airborne and underwater) from the project met established thresholds where sound may result in injury or behavioral disturbance to marine mammals.

Marine mammal monitoring for the TPP occurred between 29 August to 27 October. Work was divided into three phases, with varying levels of effort: (Phase 1 [29 August to 3 October]; Phase 2 [4 October to 20 October]; and Phase 3 [21 Oct – 27 Oct]). Phases 1 and 2 consisted primarily of marine mammal monitoring during construction activities (i.e. pile driving and removal). However, baseline line transect surveys were also conducted on non-construction (non-pile driving) days (called “red days”). Although baseline surveys were attempted in all phases, they were only conducted in Phases 1 and 3 because 1) there was less construction downtime in TPP Phase 2, and 2) no “red days” occurred in Phase 2. After completion of construction activities for the TPP on 20 October, line transect surveys to collect additional baseline data continued to be conducted as part of Phase 3 monitoring. Marine mammal monitoring efforts were concluded on 27 October and the project assets were demobilized by the end of the month (31 October).

Phase 1 required intensive biological and acoustic monitoring, with the goal of gathering sufficient data to establish acoustic isopleths corresponding to harassment and injury zones for cetaceans and pinnipeds. Once these isopleths were generally established, the number of biological and acoustic monitors in the far-field TPP project area (i.e. outside the Waterfront Restricted Area [WRA] floating fence line) were reduced slightly for Phase 2 monitoring (4 October - 20 October). During Phase 2 TPP monitoring, another pile driving project (involving pile repairs and replacement) was initiated at the existing Explosives Handling Wharf (EHW-1). The results from monitoring associated with EHW-1 pile repairs and replacement are presented in a separate report. Phase 3 of TPP monitoring occurred from 21 October – 27 October and continued the line transect surveys conducted during Phases 1 and 2. These surveys were carried out in Hood Canal and Dabob Bay to collect additional baseline data regarding marine mammal occurrence and abundance within the action area. Following Phase 3 monitoring, the project’s assets were demobilized by the end of the month (31 October). Monitoring results are reported here in the context of these work phases primarily to capture the varying monitoring techniques and levels of effort involved; however, some biologically interesting differences were detected between Phases 1 and 2, likely because of the seasonal change that occurred in this timeframe.

The marine mammal monitoring performed for this project was conducted to be in compliance with the Marine Mammal Protection Act (MMPA) permit and Endangered Species Act (ESA) consultations for the TPP. The results from this monitoring project are a part of a long-term monitoring effort under the United States (U.S.) Navy’s Marine Species Monitoring Program (Contract # N62470-10-D-3011) issued to HDR, Inc. Data collected under this contract will be

incorporated with information from other monitoring efforts which the Navy has conducted, and compiled under the Integrated Comprehensive Monitoring Program (ICMP). The ICMP was initially developed by the Navy to assist in meeting the regulatory requirements for monitoring established under the Final Rules for Navy training ranges. The ICMP serves as the overarching structure to coordinate the collection and synthesis of monitoring data from Navy training, construction, and research and development projects.

## Section 2 Methods

---

### Project Area

NBK at Bangor, Washington is located on the Hood Canal approximately 20 miles (32.19 kilometers [km]) due west of Seattle, Washington (**Figure 1**). NBK at Bangor provides berthing and support services to U.S. Navy submarines and other fleet assets. The TPP site was located within the WRA at NBK at Bangor, immediately south of the existing EHW-1 structure (**Figure 2**). Marine mammal monitoring was focused within this area and in the waters immediately adjacent to the WRA, where sound pressure levels associated with pile installation and removal activities could potentially be transmitted.

### Project Staffing

Staff for the TPP (**Table 1**) included the project manager, the monitoring coordinator (MC), marbled murrelet observers, marine mammal observers (MMOs), and acoustic technicians. Biological observers were experienced in marine mammal identification, and had extensive knowledge of the biology and behavior of locally occurring marine species. Acoustic technicians had prior experience conducting acoustic monitoring during pile driving construction projects. All marine mammal observers were dedicated to that task and served no other function while conducting observations.

### Marine Mammal Monitoring Platforms

**Vessel-based Monitoring.** Six vessels were used as observation platforms and for transportation to acoustic sampling locations. These boats included three 21 to 24-foot (6.4 to 7.3 meters [m]) aluminum hulled jet boats and three 30 to 32-foot (9.1 to 9.8 m) fiberglass monohull boats (leased from Tetra Tech EC, Inc.). Vessels were equipped with a Global Positioning System (GPS), VHF radios and depth sounders, and all captains were United States Coast Guard (USCG) certified. All captains were familiar with the Puget Sound waterways and the unique characteristics of the region. Vessels were equipped with elevated observation platforms which provided maximum viewing capability. The jet boats observation platforms were approximately two to three ft (0.6 to 0.9 m) above the water line, while the larger boats had an observation platform that were approximately 8 ft (2.4 m) above the water line. Phase 1 of the TPP required six vessels (3 inside of the WRA and 3 outside of the WRA), while Phase 2 required only four vessels (3 inside the WRA and one outside of the WRA). During Phase 3 baseline surveys, the larger inside WRA vessel was moved outside the WRA to allow for 2 vessels to conduct observations simultaneously.





Map Courtesy of NAVFAC NW

Figure 1. Vicinity Map



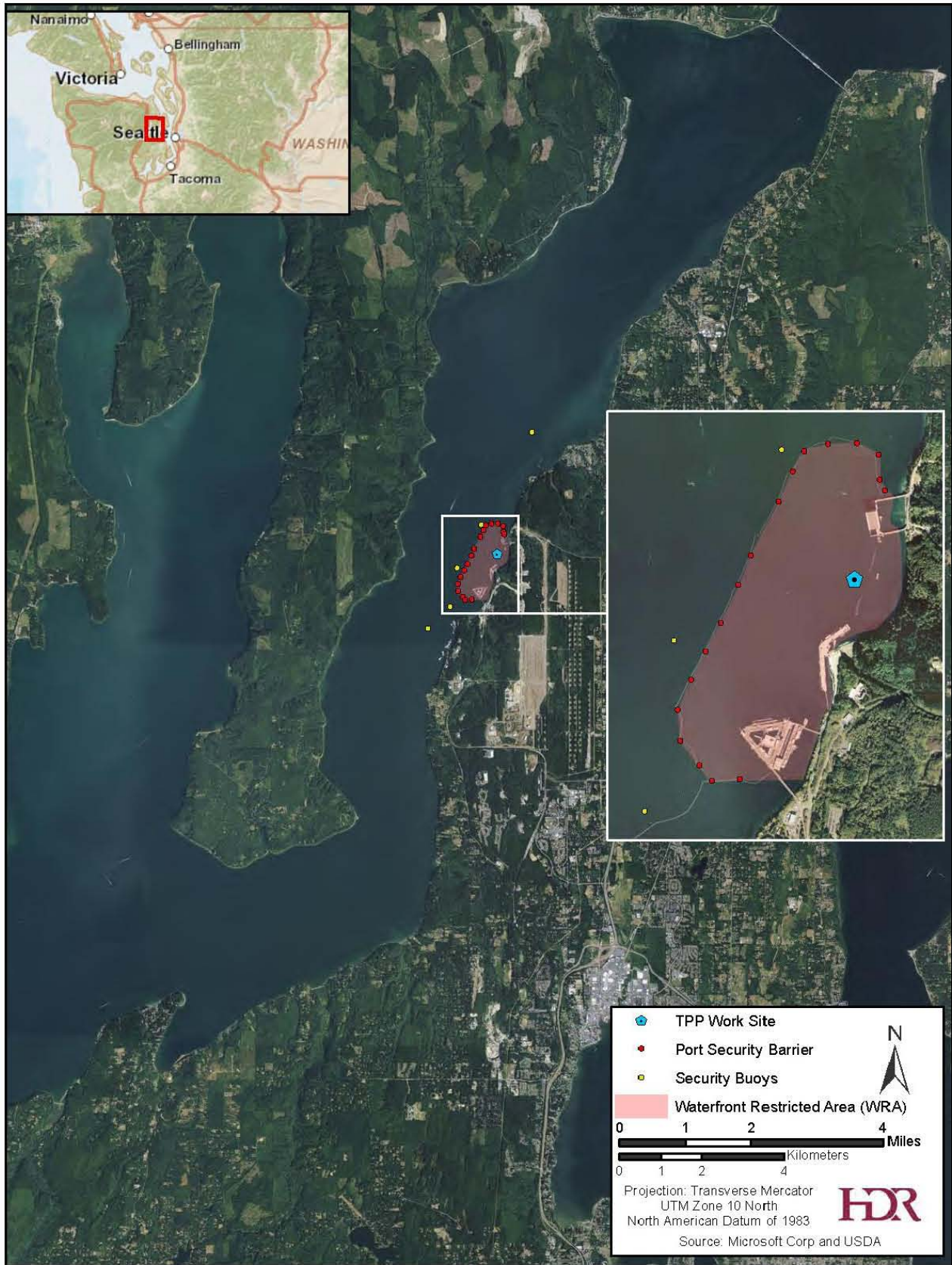


Figure 2. Project Area

**Table 1. Project Staff**

Name	Role(s)	Company
Kristen Ampela	Project Manager	HDR
Jeff Barrett	Monitoring Coordinator	Hart Crowser
Jon Houghton	Monitoring Coordinator	Hart Crowser
Jason Stutes	Monitoring Coordinator	Hart Crowser
Steve Olson	Marine Mammal Observer Coordinator	HDR
Todd McConchie	Marine Mammal Observer	HDR
Cathy Bacon	Marine Mammal Observer	HDR
Dana Spontak	Marine Mammal Observer	HDR
Stefanie Hawks-Johnson	Marine Mammal Observer	HDR
Brian McNamara	Marine Mammal Observer	HDR
Paula von Weller	Marine Mammal Observer	HDR
Mike Witter	Marine Mammal Observer	HDR
Brad Dawe	Marine Mammal Observer	HDR
Andrew Kaparos	Acoustician/Marine Mammal Observer	Hart Crowser
Emily Duncanson	Acoustician/Marine Mammal Observer	Hart Crowser
Hans Hurn	Marine Mammal Observer	Hart Crowser
Brian Payne	Acoustician	Hart Crowser
Colleen Rust	Acoustician	Hart Crowser
Jim Starkes	Acoustician	Hart Crowser
Chris Martin	Acoustician	Hart Crowser
Jason Miles	Acoustician	Hart Crowser
James Reyff	Acoustician	Illingworth & Rodkin
Keith Pommerenck	Acoustician	Illingworth & Rodkin
Jared McDaniel	Acoustician	Illingworth & Rodkin
Richard Rodkin	Acoustician	Illingworth & Rodkin
Jordan Roberts	Acoustician	Illingworth & Rodkin
Christopher Peters	Acoustician	Illingworth & Rodkin
Carrie Janelle	Acoustician	Illingworth & Rodkin
Michael Thill	Acoustician	Illingworth & Rodkin

**Pier- and Barge-based Monitoring.** After the appearance of Steller sea lions at the work site in early October, two marine mammal observers were stationed at Delta Pier (one at Delta Pier South, the other at Delta Pier North) on all construction days. These MMOs had the sole task of making detailed Steller sea lion observations, and of notifying the MC if a Steller sea lion moved toward, or entered, the water during pile driving activities. The MC was typically located on the construction barge, and served as an added marine species observer from that relatively stationary location. The MC was typically 5-10 m (16-33 ft) from the pile, and at all times had a full view of the shutdown zone. The MC was positioned in close proximity to the construction foreman, and each pile driving event was communicated between the foreman and MC. The MC

would transmit the pile specifications and other details to the observers, vessel captains, and acoustic personnel, all of whom monitored the same radio channel.

## Types of Monitoring

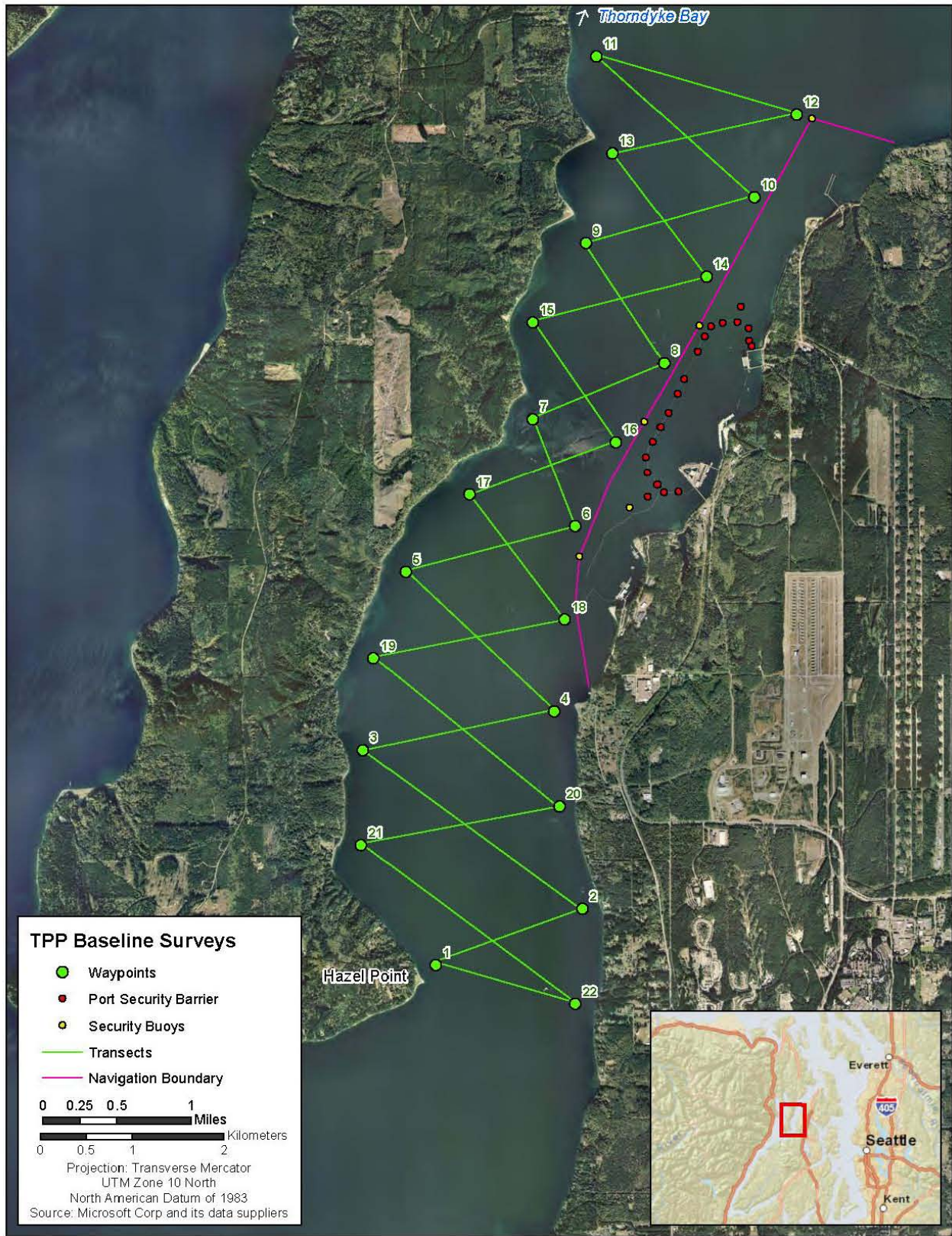
Marine mammal monitoring during pile installation and removal activities was required per the permits and consultations for the TPP. In addition to the statutorily required monitoring, the Navy conducted line transect surveys in the Hood Canal and Dabob Bay on non-pile driving days to collect baseline data on marine mammal presence and abundance. A more detailed description of these two types of monitoring efforts is provided below.

**Construction Monitoring.** During construction monitoring, several vessel-based monitoring locations were used to monitor for marine mammals to ensure their safety outside the shutdown zone and to collect observational data regarding their behavioral responses to pile installation and removal activities. Vessels were semi-stationary during construction monitoring. In the near-field vessels only moved occasionally to maintain adequate visual coverage or to collect acoustic readings. Within the far-field, the vessels moved much more frequently. Those vessels stationed to the north and south “searched” for the extent of the 120 dB root mean square (RMS) isopleth during vibratory pile driving. Once they moved into the approximate position to collect acoustic readings, the vessel remained stationary with the engines off to ensure the engine noise did not contaminate the recordings. The vessel stationed as the mid-channel communicated with the north and south far-field platforms and the near-shore observers regarding animals transiting the area or which may be approaching inbound towards the WRA. Vessel-based monitoring locations during construction were generally consistent to the positions depicted in Figures 6 and 8 of the Test Pile Marine Mammal Monitoring Plan approved by the National Marine Fisheries Service (**Appendix A**).

**Baseline Surveys.** Over the course of the TPP, there were several work days on which no in-water construction work was permitted to occur. This was usually due to temporarily heightened security restrictions at NBK at Bangor. On these days, the Navy conducted vessel-based, line-transect surveys in Hood Canal and Dabob Bay to collect additional baseline density data for species present in these waters. The primary impetus for these surveys was observational data during construction monitoring which indicated an unexpected abundance of harbor porpoise within the project area. Line transect surveys were conducted in September and October along pre-determined transects. Vessel-based observers recorded sightings of marine mammal and marbled murrelets using standard line transect methodology (Buckland et al. 2001). Four species of marine mammals were detected during the surveys (Steller sea lion, California sea lion, harbor seal, and harbor porpoise).

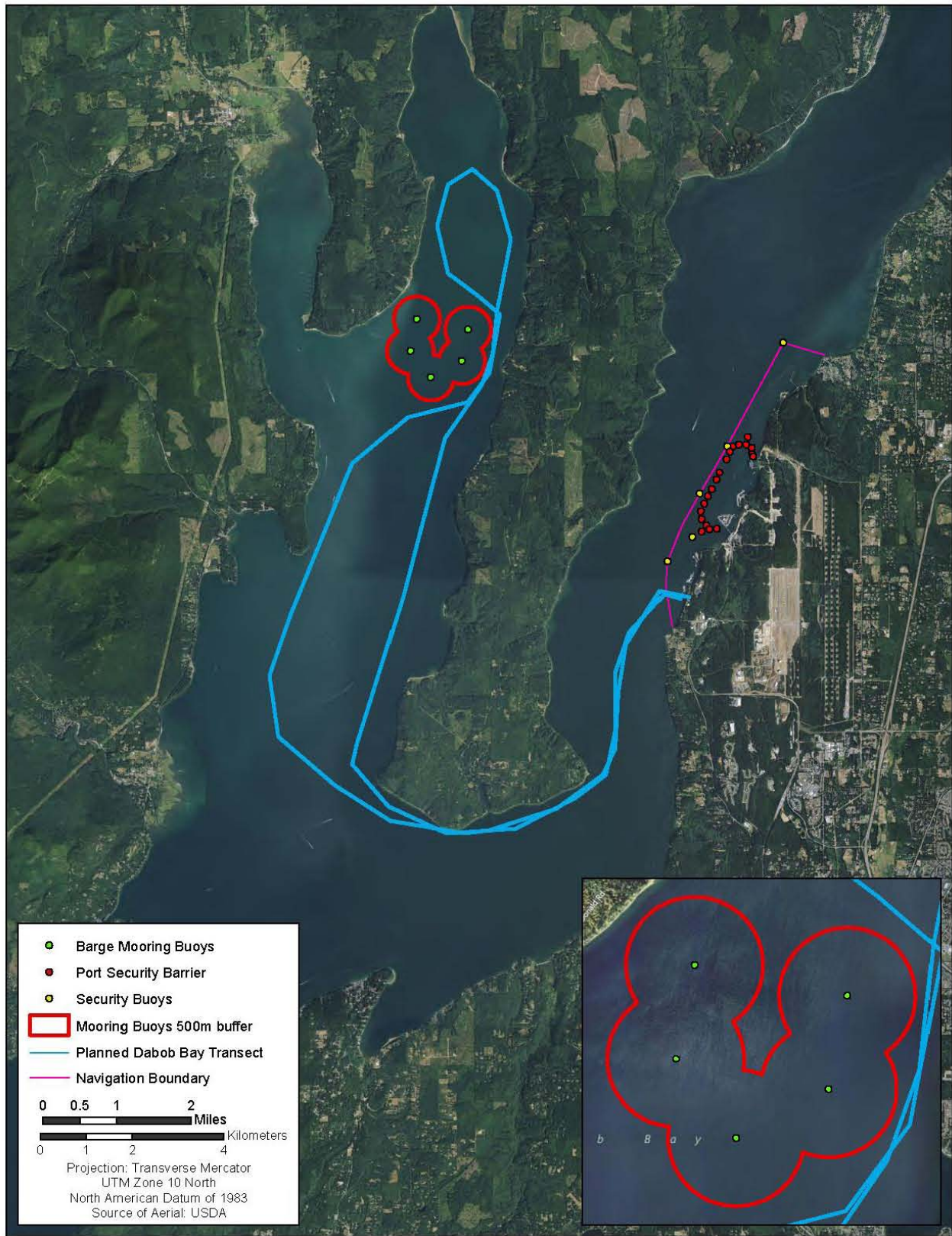
In the Hood Canal, the surveys followed a double saw-tooth pattern to achieve uniform coverage of the entire Bangor waterfront (**Figure 3**). Transects generally covered the area from Hazel Point on the south end of the Toandos Peninsula to Thorndyke Bay. Surveys in the adjacent Dabob Bay followed a slightly different pattern and generally followed more closely to the shoreline while completing a circular route through the Bay (**Figure 4**). A large exclusion zone surrounding a Navy ship moored semi-permanently in Dabob Bay made it difficult to perform zig-zag transects across the bay; therefore, early attempts at surveys in Dabob did not follow a zig-zag pattern, and switching to this survey pattern later in the project would have made density





**Figure 3. Line Transect Design for Baseline Surveys in Hood Canal**





**Figure 4. Line Transect Design for Baseline Surveys in Dabob Bay**

information collected during early “loop pattern” surveys incompatible with later data. Therefore, this loop pattern was followed during all subsequent baseline surveys in the bay. These surveys had a dual purpose of collecting marine mammal and marbled murrelet data, and shoreline surveys tended to yield more marbled murrelet sightings (Hart Crowser 2012). During surveys, the survey vessels traveled at a speed of approximately 5 knots when transiting along the transect lines. Two observers recorded sightings of marine mammals both in the water and hauled out. Marine mammal sightings data included species identification, GPS animal locations relative to vessel position, and detailed behavioral notes. Data from the line transect surveys can be used to inform improved estimates of marine mammal density in Hood Canal and Dabob Bay. Detailed information regarding these baseline surveys is included in **Appendix B**. This information was incorporated as an appendix to focus the discussion in the body of this report on those monitoring efforts that were requirements of the TPP permits or consultations.

## Monitoring Phases

Marine mammal monitoring for the TPP occurred between 29 August to 27 October in three Phases (Phase 1 [29 August to 3 October]; Phase 2 [4 October to 20 October]; and Phase 3 [21 Oct – 27 Oct]). Phase 1 and 2 consisted primarily of marine mammal monitoring during construction activities (i.e. pile driving and removal). However, baseline line transect surveys were also conducted on non-construction days during these Phases. After completion of construction activities for the TPP on 20 October, line transect surveys to collect additional baseline data continued to be conducted as part of Phase 3 monitoring. All marine mammal monitoring efforts (both construction and baseline surveys) were concluded after October 27 and the project assets were demobilized by the end of the month (31 October). Monitoring results are reported here in the context of these work phases primarily to capture the varying monitoring techniques and levels of effort involved; however, some biologically interesting differences were detected between Phases 1 and 2, likely because of the seasonal change that occurred in this timeframe.

**Phase 1.** The marine mammal monitoring for Phase 1 was designed to fully complement the intensive effort of Phase 1 Acoustic Monitoring for the TPP. The primary goal of Phase 1 was to acoustically establish an actual, versus modeled, distance to the 120-decibel (dB) RMS threshold (Level B Harassment zone). During this phase, monitoring was conducted using six boats and a minimum of six marine mammal observers (MMOs) to visually monitor the shutdown and buffer zones agreed upon during the MMPA permitting and ESA consultations. Assuming that the calculated zones of influence (ZOIs) were not field verified to be smaller, then this Phase represented the maximum level of effort required.

Phase I monitoring was performed over the period from 29 August to 3 October 2011 (**Table 2**). The area monitored on any given day ranged from 5.1 to 53 square kilometers [ $\text{km}^2$ ] (1.5 to 15.4 square nautical miles [ $\text{nm}^2$ ]). During construction monitoring, vessel tracks varied with construction activities and monitoring requirements, but focused in and around Hood Canal and the WRA near NBK at Bangor. Baseline survey efforts during Phase I in Hood Canal and Dabob Bay are summarized in **Table 3**.

**Table 2. Summary of Phase I Construction Monitoring Efforts for the TPP Pile Driving Project**

Date	Approximate Area Covered (km <sup>2</sup> )	Start Time (hh:min)	End Time (hh:min)	Total Time (hh:min)
<b>Construction Monitoring</b>				
29-Aug-2011	20.3	09:00	15:53	06:53
30-Aug-2011	21.0	08:10	16:30	08:20
31-Aug-2011	32.6	07:30	15:20	07:50
1-Sep-2011	7.0	07:50	16:36	08:46
8-Sep-2011	27.4	08:10	17:45	09:35
10-Sep-2011	44.8	07:21	17:37	10:16
15-Sep-2011	11.6	09:15	17:00	07:45
16-Sep-2011	9.9	08:30	16:47	08:17
17-Sep-2011	12.9	08:30	16:49	08:19
21-Sep-2011	14.8	08:20	17:30	09:10
22-Sep-2011	11.7	08:25	16:01	07:36
23-Sep-2011	17.6	08:17	16:51	08:34
24-Sep-2011	16.0	08:38	16:45	08:07
26-Sep-2011	5.1	08:24	12:06	03:42
29-Sep-2011	53.0	08:39	17:40	09:01
30-Sep-2011	20.0	08:20	16:20	08:00
1-Oct-2011	11.0	08:14	17:04	08:50
3-Oct-2011	15.0	08:39	18:39	10:00
<b>TOTAL</b>				<b>149:01</b>

**Phase 2.** Acoustic data collected during Phase 1 of the TPP, in particular the estimated distance to the 120 dB threshold, was used during Phase 2 to refine the amount of effort needed to effectively monitor the remainder of the project. Phase 2 monitoring employed four vessels (three inside and one outside the WRA) with a minimum of four MMOs, one on each vessels. During this phase of monitoring, a pile replacement project at EHW-1 overlapped with TPP pile project operations; however, pile driving for either project did not occur at the same time. As such, data and estimated takes were logged separately and results are presented in two separate reports. The observers in place for TPP also served as the marine mammal observers for EHW-1 since the behavioral impact zone from vibratory pile driving for TPP and EHW-1 was essentially the same.

Phase 2 monitoring was performed over the period from 4 October to 20 October 2011 (**Table 4**). The area monitored on any given day ranged from 3.6 to 18.1 square kilometers [km<sup>2</sup>] (1 to 5.28 square nautical miles [nm<sup>2</sup>]). During construction monitoring, vessel tracks varied with construction activities and monitoring requirements, but focused in and around Hood Canal and the WRA near NBK at Bangor. Due to the intensive construction schedule during Phase 2, there were no non-pile driving days available to conduct baseline surveys.

**Table 3. Summary of Phase I Baseline Survey Efforts for the TPP Pile Driving Project**

Date	Approximate Area Covered (km <sup>2</sup> )	Start Time (hh:min)	End Time (hh:min)	Total Time (hh:min)
<b>Baseline Surveys – Hood Canal</b>				
13-Sep-2011	41.65	09:11	12:23	03:12
14-Sep-2011	44.54	08:10	11:45	03:46
19-Sep-2011	46.74	08:10	11:49	03:39
20-Sep-2011	41.08	08:21	12:11	03:50
27-Sep-2011	45.00	08:30	12:22	03:52
28-Sep-2011	40.00	08:50	12:30	03:40
<b>TOTAL</b>				<b>21:59</b>
<b>Baseline Surveys – Dabob Bay</b>				
13-Sep-2011	40.80	08:56	12:20	03:24
14-Sep-2011	41.14	08:38	11:56	03:18
19-Sep-2011	38.80	08:35	11:45	03:10
20-Sep-2011	59.53	08:20	11:48	03:28
27-Sep-2011	46.00	08:45	12:00	03:15
28-Sep-2011	48.00	08:58	12:25	03:27
<b>TOTAL</b>				<b>20:02</b>

**Table 4. Summary of Phase II Construction Monitoring Efforts for the TPP Pile Driving Project**

Date	Approximate Area Covered (km <sup>2</sup> )	Start Time (hh:min)	End Time (hh:min)	Total Time (hh:min)
<b>Construction Monitoring</b>				
4-Oct-2011	8.0	07:50	16:42	08:52
5-Oct-2011	7.0	07:06	17:23	10:17
6-Oct-2011	18.1	07:50	17:35	09:45
7-Oct-2011	8.3	07:25	18:19	10:54
8-Oct-2011	3.6	08:05	17:00	08:55
10-Oct-2011	5.0	11:15	17:23	06:08
11-Oct-2011	6.2	07:50	18:19	10:29
12-Oct-2011	4.8	07:45	18:45	11:00
13-Oct-2011	4.8	07:45	15:45	08:00
14-Oct-2011	5.6	11:03	17:45	06:42
15-Oct-2011	9.8	08:09	13:42	05:33
17-Oct-2011	17.7	08:09	17:15	09:06
18-Oct-2011	5.3	08:08	16:00	07:52
19-Oct-2011	5.4	07:48	16:41	08:53
20-Oct-2011	4.8	07:57	16:05	08:08
<b>TOTAL</b>				<b>130:34</b>

**Phase 3.** Phase 3 monitoring consisted exclusively of conducting baseline marine mammal line transect surveys in Hood Canal and Dabob Bay as pile driving and removal activities for the TPP were complete. Phase 3 monitoring was performed over the period from 21 October to 27 October 2011. The area monitored on any given day ranged from 3.0 to 52.3 square kilometers [km<sup>2</sup>] (0.9 to 15.2 square nautical miles [nm<sup>2</sup>]). Baseline survey efforts during Phase 3 in Hood Canal and Dabob Bay are summarized in **Table 5**.

**Table 5. Summary of Phase II Baseline Survey Efforts for the TPP Pile Driving Project**

Date	Approximate Area Covered (km <sup>2</sup> )	Start Time (hh:min)	End Time (hh:min)	Total Time (hh:min)
<b>Baseline Surveys – Hood Canal</b>				
21-Oct-2011	31.10	09:05	12:00	02:55
22-Oct-2011	33.60	09:18	11:25	02:07
24-Oct-2011	47.50	09:30	13:00	03:30
25-Oct-2011	45.06	09:38	12:40	03:02
26-Oct-2011	43.81	11:30	14:00	02:30
<b>TOTAL</b>				<b>14:04</b>
<b>Baseline Surveys – Dabob Bay</b>				
24-Oct-2011	52.30	10:05	12:55	02:50
25-Oct-2011	37.03	09:45	13:00	03:15
26-Oct-2011	3.00	13:40	13:57	00:17*
<b>TOTAL</b>				<b>06:22</b>

\* Boat had to turn back at Hazel Point due to high winds and sea states, precluding further monitoring.

**All Phases.** In total, the Navy completed 279 hours and .35 minutes of marine mammal surveys on construction days and another 62 hours and 27 minutes (36 hours and 3 minutes in Hood Canal and 26 hours and .24 minutes in Dabob Bay) of line transect baseline surveys on non-construction days during the course of the TPP.

## Monitoring Zones

The acoustic modeling results presented within the Environmental Assessment, Biological Assessment, and the request for an Incidental Harassment Authorization (IHA) were used to develop the shutdown and buffer zones for pile installation and removal activities associated with the Test Pile Program. While the acoustic zones of influence varied among the different diameter piles, and types of installation and removal methodologies, shutdown and buffer zones were based on the modeled maximum zone of influence for all pile installation and removal activities. The monitoring zones were created to delineate locations that are important to species that are sensitive to spaces around the project area. Monitoring of these zones and the implementation of other minimization measures, such as the use of sound attenuation devices, was designed to reduce the impacts of underwater sound from pile driving/removal on these species.



**Shutdown Zone.** The shutdown zone included all areas where the underwater sound pressure levels (SPLs) were anticipated to equal or exceed the Level A (injury) Harassment criteria for marine mammals (180 decibels referenced to 1 micropascal [dB re 1  $\mu$ Pa] isopleths for cetaceans; 190 dB re 1 $\mu$ Pa isopleths for pinnipeds). For impact and vibratory pile installation and removal, monitoring was conducted for a 164-foot (50-m)<sup>1</sup> shutdown zone (Level A Harassment) surrounding each pile for the presence of marine mammals before, during, and after pile operations.

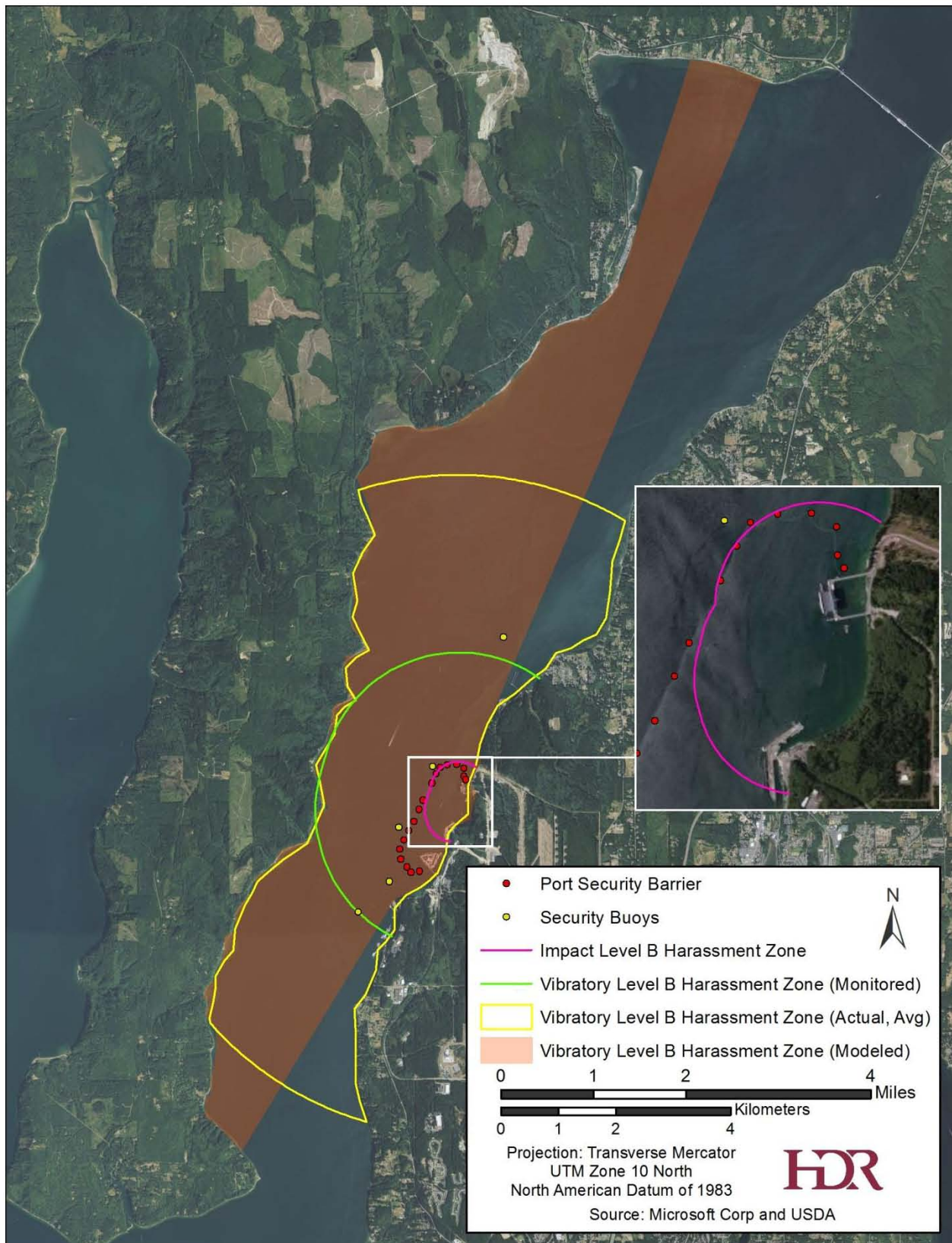
**Buffer Zone.** The buffer zone included all areas where the underwater or airborne sound pressure levels were anticipated to equal or exceed the Level B (behavioral disturbance) Harassment criteria for marine mammals (160 dB re 1 $\mu$ Pa - impact hammer; 120 dB re 1 $\mu$ Pa - vibratory hammer; 90 or 100 dB re 20 $\mu$ Pa - airborne). For impact pile installation, modeling indicated that the Level B harassment zone extended to 1,522.3 feet (ft) [464 m] surrounding each pile. MMOs checked for the presence of marine mammals in the harassment zone before, during, and after impact pile driving activities. To be conservative, this zone was extended to 1,640.4 ft (500 m) for the purposes of monitoring (**Figure 5**). For vibratory pile installation and removal activities, modeling predicted an affected area of 41.5 km<sup>2</sup> (12.1 nm<sup>2</sup>) for the 120 dB RMS disturbance criterion. Due to the difficulty of effectively monitoring such a large area, the U.S. Navy and the NMFS agreed to monitor an area north, south, and west of the construction area equivalent to the width of the Hood Canal (2.4 km [1.3 nautical miles (nm)]) (**Figure 5**). This area was monitored for the presence of marine mammals before, during, and after pile installation and removal activities. The actual distance to the 120 dB disturbance threshold was calculated to fall (on average) at a 5.7 km (3.1 nm) radius from the pile, covering a 32.6 km<sup>2</sup> (9.5 nm<sup>2</sup>) area (**Figure 5**). Boat captains and observers were equipped with vessel-mounted and hand-held GPS units in order to ensure correct positioning and effective coverage of shutdown and buffer zones.

### Observer Construction Monitoring Locations

In order to properly monitor buffer and shutdown zones, MMOs were positioned at various vessel- and land-based vantage points, taking into consideration security, safety, and space limitations at the NBK at Bangor waterfront. Three monitoring vessels were positioned inside the WRA, in addition to the construction-related vessels (i.e., barges, tugs, etc.). Between one and three monitoring vessels were stationed outside the WRA according to the project phase. Inside the WRA, marine mammal observers were occasionally placed on the construction barge when: (1) complete MMO coverage could not be accomplished any other way, and/or (2) when the hydrophones located on the barge needed to be repositioned or otherwise maintained. As described above, the MC was stationed on or near the construction barge, and served as an additional MMO when needed. When an MMO was on a barge, appropriate protective gear was required and worn at all times. After the appearance of Steller sea lions in the WRA in early October, a dedicated MMO was placed on the Delta Pier structure (**Figure 6**) in order to monitor the behavior, number and position of these animals during all construction activities.

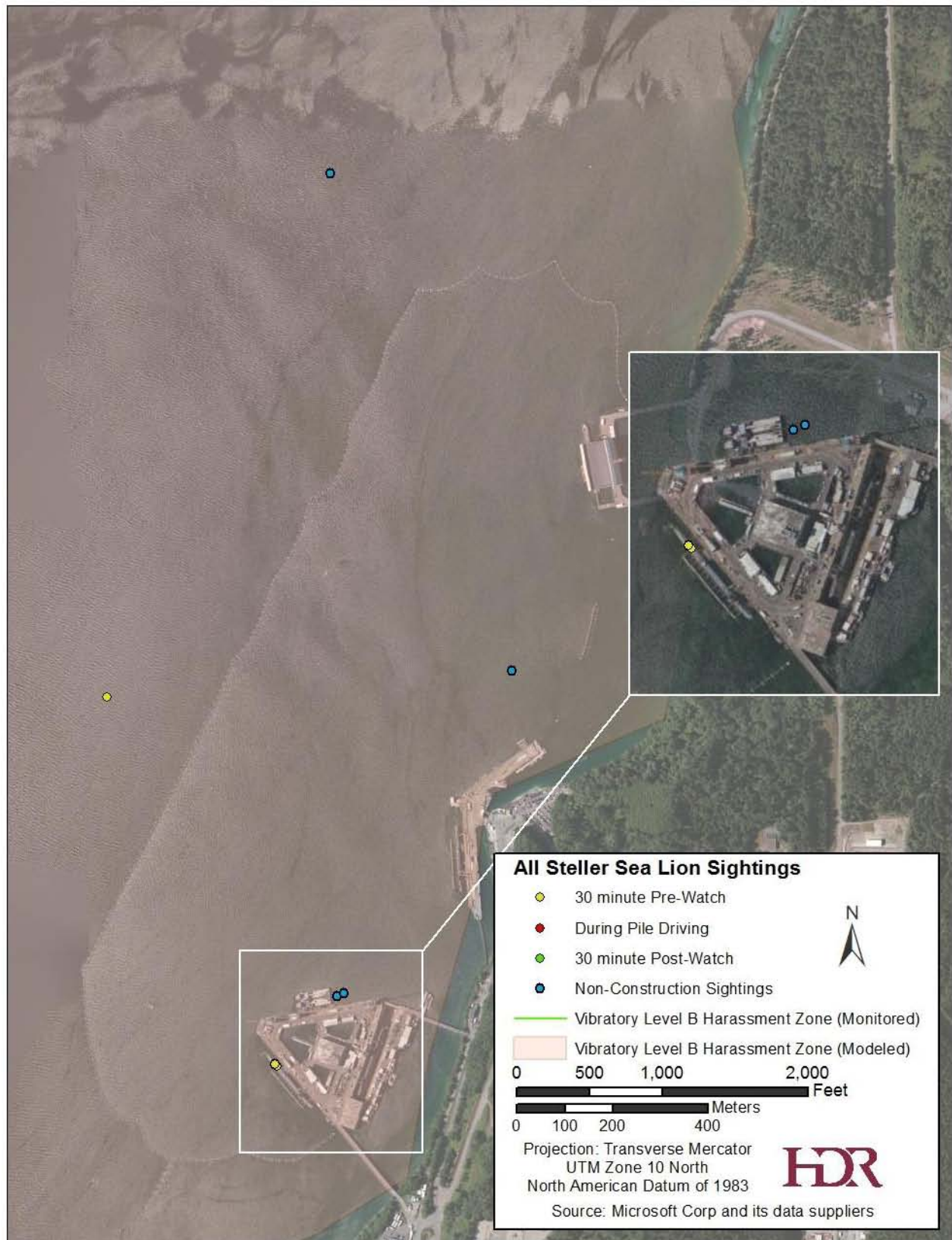
---

<sup>1</sup> Based on coordination with NMFS HQ, a minimum shutdown zone of 164 ft (50 m) was recommended to standardize monitoring activities at the NBKB waterfront, even though this zone is slightly larger than the modeled Level A harassment zone. This measure will be implemented for impact and vibratory pile installation and removal activities. This mitigation only applies to marine mammals.



**Figure 5. Modeled, Monitored, and Actual Level B Harassment Zones**





**Figure 6. All Steller sea lion sightings. Points may represent more than one individual.**

The following boat locations for Phases 1 and 2 of construction (see **Figures 7 and 8**) were identified to provide adequate visual coverage during all construction activities:

*Near-field Boat Locations:*

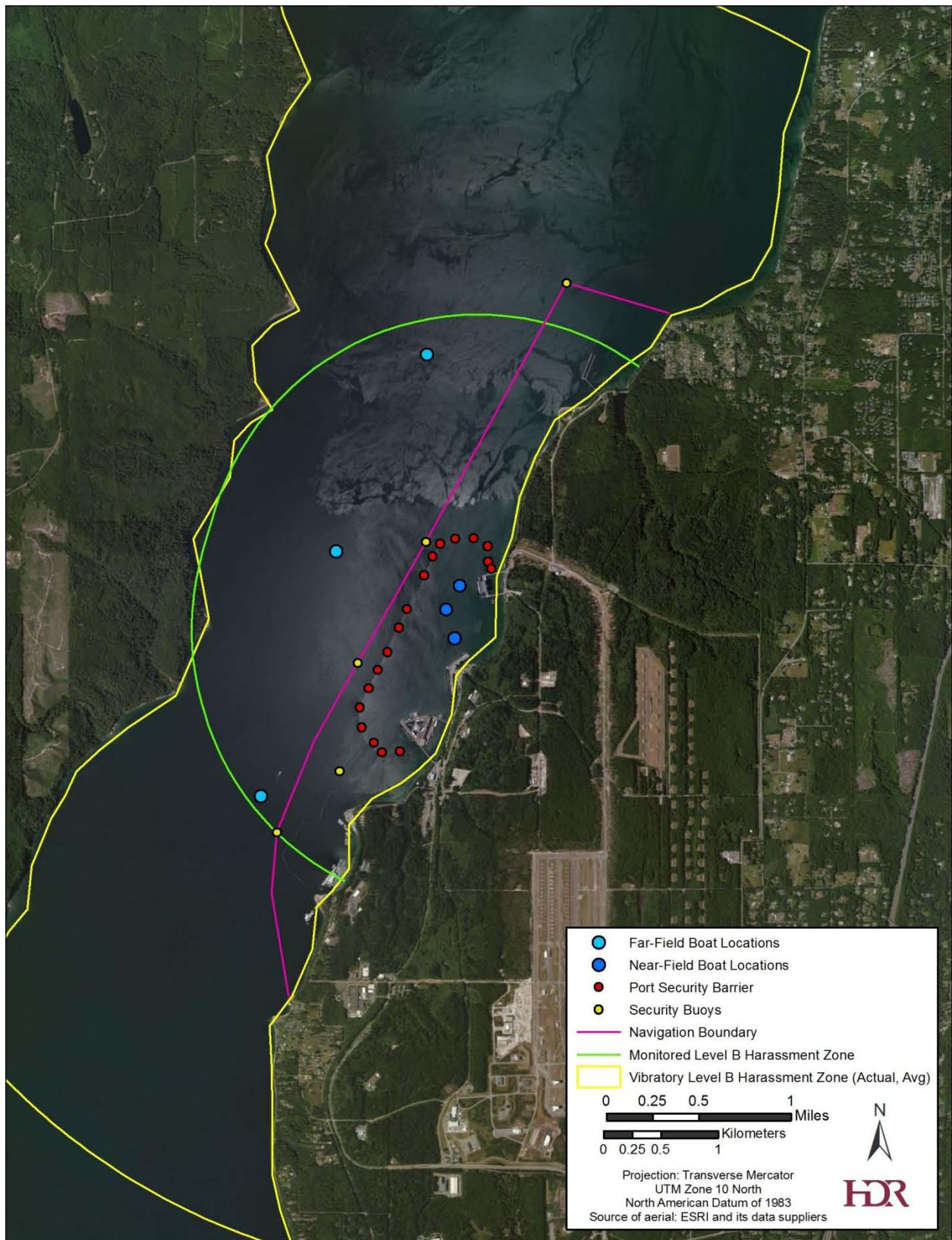
- *North Monitoring Boat (Phases 1 and 2):* Small boat vantage point within the WRA that monitored the injury zone and impact behavioral disturbance zone to the north of each pile location. This boat accommodated both marine mammal and marbled murrelet observers. During impact pile driving, the boat undertook a circular transect pattern to aid in marble murrelet monitoring. At all other times, the boat used a transect search pattern or was stationary and positioned at a location to provide the best vantage point.
- *South Monitoring Boat (Phases 1 and 2):* Small boat vantage point within the WRA that monitored the injury zone and impact behavioral disturbance zone to the south of each pile location. This boat accommodated both marine mammal and marbled murrelet observers. During impact pile driving, the boat undertook a circular transect pattern to aid in marble murrelet monitoring. At all other times, the boat used a transect search pattern or was stationary and positioned at a location to provide the best vantage point.
- *West Monitoring Boat (Phases 1 and 2):* Small boat vantage point within the WRA that monitored the injury zone and impact behavioral disturbance zone to the west of each pile location. This boat was used for acoustic monitoring and also accommodated marine mammal observers.

*Far-Field Boat Locations:*

- *North far-field location (Phase 1):* Small boat vantage point located at the northern edge of the 1.3 nm (2.4 km) observable zone.
- *Mid-Channel boat location (Phases 1 and 2):* Small boat vantage point located in the middle of the Hood Canal due west of the Test Pile Program location.
- *South far-field location (Phase 1):* Small boat vantage point located at the southern edge of the 1.3 nm (2.4 km) observable zone.

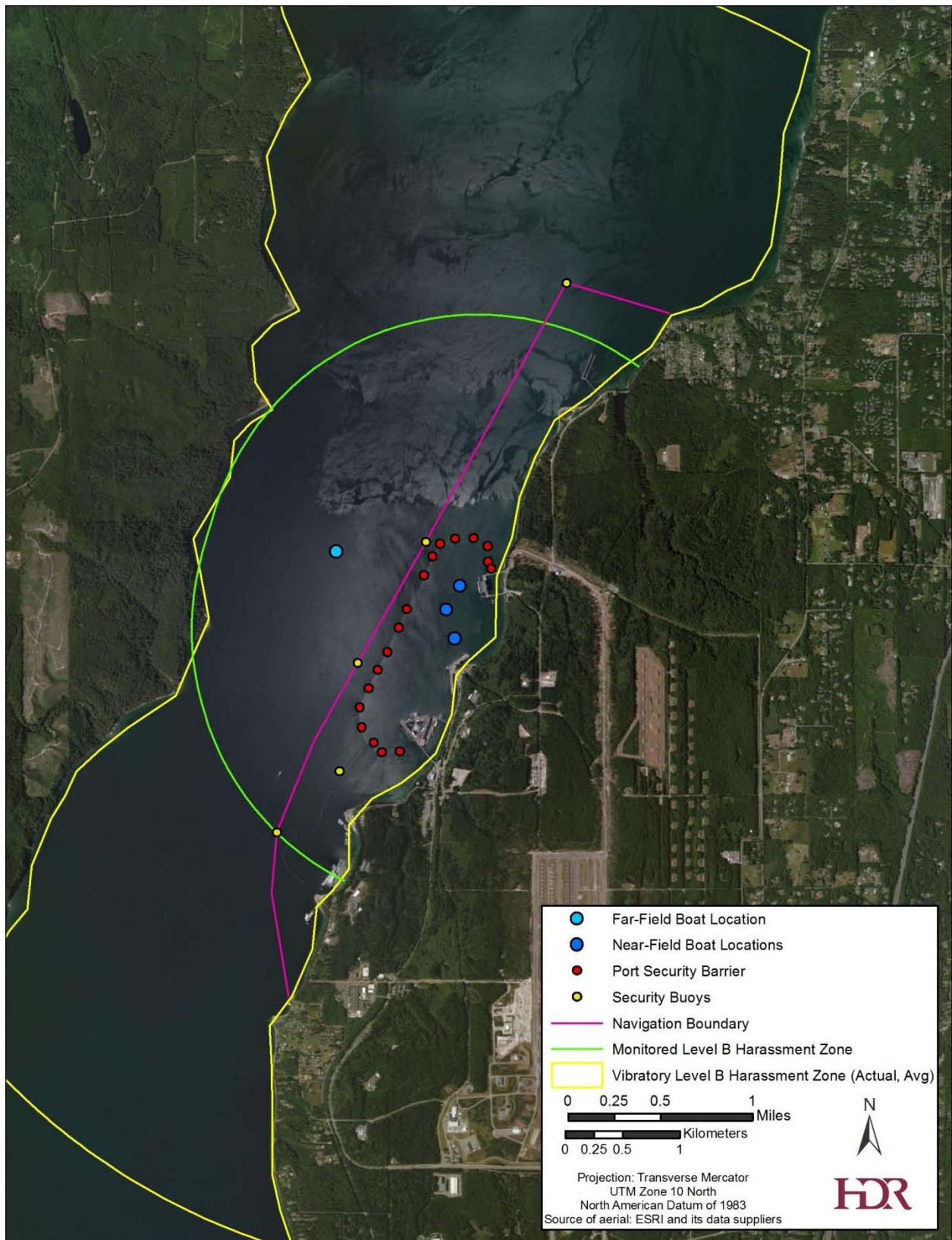
Each monitoring boat had a minimum of one dedicated marine mammal observer. In-situ acoustic monitoring was used to determine the actual extent of the 120 dB RMS behavioral disturbance zone.

***Environmental Data.*** Environmental parameters were measured at intervals inside and outside of the WRA. Where operating schedules permitted, environmental data was collected at the top of each hour. During active operations, environmental data were collected as opportunity allowed. Boat-based instruments were used to gauge water temperature and depth. Anemometers were used to determine wind speed, humidity and air temperature. Visual observations of wave height, wind direction, and weather conditions were also included in the data (**Appendix C**).



**Figure 7. Phase 1 Boat Locations Relative to Monitored and Actual Level B (Behavioral Disturbance) Harassment Zones**





**Figure 8. Phase 2 Boat Locations Relative to the Monitored and Actual Level B (Behavioral Disturbance) Harassment Zones**

## Monitoring Techniques

Actual pile installation and removal activities occurred intermittently throughout each construction day. In order to gather the maximum amount of data possible, and to better characterize marine species occurrence and behavior in the area, marine species observers surveyed Hood Canal waters, both inside and outside the WRA, throughout the day, regardless of whether or not pile driving was occurring at that time. Therefore, data gathered on construction days includes observations made during construction and non-construction periods. Construction monitoring of the shutdown and buffer zones took place from 30 minutes prior to initiation of pile driving through 30 minutes post-completion of all pile installation and removal activities. Pile driving was not initiated until the shutdown zone was clear of marine mammals. When an animal or group of animals was sighted, a series of observations were recorded in order to correlate sightings with other data points. Times of the sighting, number of animals, behavior, distance and bearing to the animal(s), and distance to pile were recorded in hardcopy format using a standardized Marine Mammal Sightings form (**Appendix D**). A worksheet with data codes was provided to each observer in order to provide a series of project-specific, weather, species, and behavioral codes to enter into the sightings sheets on a per sighting basis (**Appendix E**). At the end of each day, sighting sheets from each monitoring boat were scanned electronically for storage in PDF format. All data were also recorded in spreadsheet format and archived electronically. Standard equipment for each boat included binoculars (7 x 50) with installed reticles, a hand-held GPS unit, radio, clipboard/notebook, and site-specific marine mammal identification guide (Whales and Other Marine Mammals of Washington and Oregon, Eder and Sheldon 2001).

To minimize the probability of multiple observers counting a single animal twice (and potentially overestimating takes) sightings were tracked on a continuous basis by an observer on one vessel, and then “handed off” to an observer on a second vessel if the animal(s) headed in the direction of the second vessel. Every attempt was made to protect marine mammals from Level A (injury) Harassment via (1) the use of sound attenuation devices, and (2) continuous monitoring of the behavioral harassment and near-field injury zones. One hundred percent coverage of the Level B [behavioral] harassment zone during vibratory pile driving/removal was not possible due to the large area involved and limited number of monitoring vessels. The efficacy of visual detection of marine mammals depended on several factors, including the observer’s ability to detect the animal, the environmental conditions (visibility and sea state), and the position of the monitoring platforms. Pile driving was halted when a marine mammal was sighted within the 164 ft (50 m) shutdown zone during pile driving activities.

### *Visual Monitoring Protocol*

*Pre-Activity Monitoring.* Prior to the start of pile operations, the shutdown and buffer zones were monitored for 30 minutes to document the presence of marine mammals. The following monitoring methodology was implemented prior to commencing pile installation/removal activities:

- Near-field observers monitored the shutdown zone and buffer zones. They ensured that no marine mammals were seen within the shutdown zone before pile driving began;

- If marine mammals were present within or approaching the shutdown zone prior to pile driving, or the soft-start<sup>2</sup>, monitoring continued and the start of pile driving was delayed until the animals left the shutdown zone voluntarily.
- If marine mammals were not within the shutdown zone (i.e. the zone was deemed clear of marine mammals), the observers radioed the Monitoring Coordinator who then radioed the Pile Driving Engineer Lead that pile driving could commence;
- The monitoring boat(s) stationed outside the WRA and monitoring the 120 dB RMS zone (see **Figures 7 and 8**) looked for the presence of marine mammals and radioed to near-field observers if marine mammals were traveling toward the near-field.
- Marine Mammal Sightings forms were used to document observations (**Appendix D**).

*During Activity Monitoring.* The shutdown and buffer zones were monitored throughout the time required to install or remove a pile. The following monitoring methodology was implemented during pile operations:

- If a marine mammal was observed entering the 500 m (1,640.4 ft) impact pile driving behavioral disturbance zone or the 2.4 km (1.3 nm) vibratory pile driving behavioral disturbance zone, a “take” was recorded and behaviors documented. However, that pile segment would be completed without cessation unless the animal entered or approached the shutdown (injury) zone, at which point all pile installation/removal activities were halted. The observers immediately radioed to alert the Pile Driving Lead Engineer and/or raised a red flag. This action required an immediate “all-stop” on pile operations.
- Pile installation/removal activities were delayed until the animal voluntarily left the shutdown zone and had been visually confirmed beyond the shutdown zone, or 30 minutes had passed without re-detection of the animal.
- During the pile driving delay, monitoring continued to be conducted and pile driving did not resume until the shutdown zone had been deemed clear of all marine mammals.
- If marine mammals were detected outside the shutdown zone, the observers continued to monitor these individuals and recorded their behavior, but pile driving proceeded. Any marine mammals detected outside the shutdown zone after pile driving was initiated continued to be monitored and their behaviors recorded.
- Marine Mammal Sighting forms were used to document observations (**Appendix D**);
- Any monitoring boats engaged in marine mammal monitoring maintained speeds equal to or less than 10 knots;
- Experienced marine mammal observers were trained to accurately verify species sighted;
- Observers used binoculars and the naked eye to search continuously for marine mammals;

---

<sup>2</sup> The Test Pile Program utilized soft-start techniques recommended by NMFS for impact and vibratory pile driving. For an impact hammer, contractors were required to provide an initial set of three strikes from the impact hammer at approximately 40 percent energy followed by a 1-minute waiting period, then two subsequent 3- strike sets. For a vibratory hammer, the soft start requires the contractor to initiate noise from the vibratory hammer for 15 seconds at reduced energy followed by a 1-minute waiting period. This procedure was repeated two additional times.

- In case of fog or reduced visibility, the observers had to be able to see the shutdown and buffer zones or pile driving was not initiated until visibility in these zones improved to acceptable levels;
- The above-described monitoring efforts were run concurrently with the marbled murrelet monitoring protocols.

*Post-Activity Monitoring.* Monitoring of the shutdown and buffer zones continued for 30 minutes following completion of pile installation and/or removal activities. These monitoring efforts focused on observing and reporting unusual or abnormal behavior of marine mammals. During these efforts, if any injured, sick, or dead marine mammals were observed, the U.S. Navy was to notify NMFS immediately. Monitoring results were noted on the Marine Mammal Sighting form (**Appendix D**).

### ***Acoustic Monitoring***

Acoustic monitoring was conducted during impact and vibratory installation and removal activities associated with the Test Pile Program in order to determine the actual distances to the underwater and airborne thresholds for marine mammals and pinnipeds. These included the 190-dB re 1 $\mu$ Pa RMS, 180-dB re 1 $\mu$ Pa RMS, 160-dB re 1 $\mu$ Pa RMS and 120-dB re 1 $\mu$ Pa RMS underwater isopleths, and the 100-dB re 20  $\mu$ Pa and 90-dB re 20  $\mu$ Pa unweighted airborne isopleths. Unless otherwise stated, underwater sound pressure is defined as sound pressure level (SPL) in decibels (dB) referenced to one micropascal (re 1  $\mu$ Pa). Airborne sound pressure is defined as sound pressure level (SPL) in decibels (dB) referenced to 20 micropascals (20  $\mu$ Pa). The injury and behavioral harassment thresholds for marine mammals are defined as follows:

#### **Underwater Injury Zones:**

- a. 180 decibels (dB) RMS isopleth for cetaceans
- b. 190 dB RMS isopleth for pinnipeds

#### **Underwater Behavioral Harassment Zones:**

- a. 160 dB RMS for marine mammals during impact pile driving
- b. 120 dB RMS for marine mammals during vibratory driving

#### **Airborne Behavioral Harassment Zones:**

- a. 100 dB RMS for all pinnipeds except harbor seals, during impact and vibratory pile driving
- b. 90 dB RMS for harbor seals, during impact and vibratory pile driving.

Hydrophones/microphones were placed at varying distances and depths as appropriate to accurately capture sound propagation characteristics in the Test Pile Program area. Hydro-acoustic monitoring was also employed to determine the relative effectiveness of an underwater sound attenuation device (bubble curtain) used during the Test Pile Program. Ambient underwater and airborne conditions in the absence of construction activities were recorded for comparison. The U.S. Navy's Acoustic Monitoring Plan provides the specific

details of the acoustic monitoring requirements and protocol for both underwater and airborne sounds from the Test Pile Program.

Underwater sound measurements were conducted at positions near pile driving and distant locations. Measurements were conducted from the construction barge that was typically 10 meters distance from the pile. Sound measurements were typically taken at two depths: one at 10 meters, and the other at 20 meters or 1 meter above the bottom, depending on water column depth. The hydrophones at the construction barge were unattended, and had to be positioned such that tidal depth would not cause them to interfere with the seafloor. In addition, up to 10 meters of hydrophone signal line were necessary to deploy the hydrophones from the barge work area. Measurements were conducted inside the WRA at varying distances that typically ranged from 90 to 200 meters. Measurements were also conducted outside the WRA at distances that were typically beyond 800 meters. Most of the hydrophones and microphones recorded data continuously and were downloaded periodically to obtain the raw data. However, some of the acoustic recording equipment provided readings in “real-time” on sound level meters (SLMs).

*Stationary Hydrophones.* All SLMs were calibrated to the hydrophone response with the piston phone signal at the beginning of each day. The response of SLMs to the calibration tone was noted in field logbooks and logged by the SLM, which was downloaded after each day with a pile driving event. SLMs were used for real-time recorders only, i.e. all but those on the construction barge and raft, where recordings were made. A backup SLM was used to collect limited data in case of a recording failure, which occurred on a few occasions.

A stationary 2-channel hydrophone recording system was suspended from the pile driving barge approximately 33 ft (10 m) from each pile. One hydrophone was placed mid-depth and the other closer to the bottom. Depth of the hydrophones with respect to the bottom varied due to tidal changes and current effects. The hydrophones recorded continuously during pile driving and the data was analyzed after the completion of the project.

In addition to the hydrophone array on the barge, a two-channel stationary hydrophone array was deployed near the Toandos Peninsula at approximately 5,905 to 7,875 ft (1800–2400 m) from the pile. This set of hydrophones hung from an anchored raft and recorded continuously during pile driving. One hydrophone was suspended at approximately mid-depth at mean water depth and the other at a position approximately 2.0 ft (0.61 m) above the bottom at low tide.

*Vessel-Based Hydrophones and Microphones.* One acoustic vessel, the *Silver Streak*, was equipped with a two-channel hydrophone array which was used inside the WRA to monitor near-field and real-time isopleths for marbled murrelets. The SLMs attached to these hydrophones collected data in real time. The RMS sound pressure level was measured for each pile strike at each position. This was measured using the “impulse” setting on the sound level meter that provides the maximum RMS over a 35-milli-second period for each second that impact pile driving occurred. The maximum impulse level occurring over each second of impact pile driving was reported. Use of the 35-milli-second impulse level provides a slight overestimate of the RMS, since the pulse duration is typically 50 to 100 milliseconds, with most energy confined to 30 to 50 milliseconds. The *Silver Streak* was also equipped with an airborne microphone to record airborne sounds.



*Stationary Microphones.* For each pile being driven, a stationary microphone was located on the pile driving barge at approximately 50 ft (15.2 m) from the pile to record airborne sound levels. In addition, two land-based microphones were placed on shore between the EHW-1 and Marginal Wharf. The land-based microphones were placed according to ease of access to the beach. All airborne data were recorded and analyzed after completion of the project.

## **Piles and Pile driving Equipment**

*Pile Descriptions.* During the Test Pile Program, 23 steel piles were driven by vibratory and impact hammers. Some of the piles were installed more than once. For instance, two piles, TP-3 and TP-9, had three reaction batter piles driven around them and platforms constructed on top of them to permit additional engineering testing. This resulted in a total of 29 installation events. Test piles ranging in size from 24 to 48 inches (0.61 to 1.22 m) in diameter and 155 to 198 ft (47.2 to 60.4 m) in length were installed (**Table 6**).

*Pile Driving Equipment.* Pile driving equipment was provided and operated by Manson Construction Co. Two vibratory (APE 400 and APE 600) and two impact hammers (APE D80 and APE D100) were used during the project, though only one hammer was in operation at any time. The APE 400 and APE 600 have drive forces of 361 tons and 556 tons, respectively. Up to four piles were permitted to be installed per day using a vibratory hammer. Multiple impact drives were allowed per day, but no more than 100 total strikes were allowed in a single day with a maximum of 1,500 strikes for the entire project.

Impact hammers APE D80 and Ape D100 were rated for 198,450 ft-pounds (lbs) and 248,063 ft-lbs, respectively. The APE 400 was used on piles TPP-1 and TPP-3, while APE 600 was used for the remaining vibratory driven piles and to finish driving TTP-3. Similarly, APE D80 was used to impact piles TP-1, TP -2 and a batter pile for TP-3. The APE D100 was used to install the remainder of the impact driven piles (**Table 6**). In total, there were 23 instances where piles were driven with an impact hammer, and therefore required formal monitoring for marbled murrelets. Marbled murrelet monitoring methods and findings are presented in a separate report (Hart Crowser, 2012).

A sound attenuation bubble curtain was utilized during most impact driving of the test piles (see **Appendix F** for design specifications of air bubble curtain sound attenuation system). The bubble curtain was turned off for a short period of time (1 minute or less) during the impact driving of seven piles to allow the acoustics monitoring staff to test the effectiveness of the sound attenuation system. The bubble curtain was designed with seven rings placed no further than 15 feet (4.6 m) apart, and were constructed of 3-inch (7.6 centimeter [cm]) diameter pipe rolled into a circle 4 feet, 10 inches (1.5 m) in diameter at the center of the pipe, with 1/8-inch (0.3-cm) holes on the bottom spaced 2 inches (5.1 cm) apart. Each ring was required to pass approximately 501 cubic feet per minute (cfm) (14.2 cubic meters [m<sup>3</sup>]/minute [min]) of oil-free air to meet the requirements, and usually ran at approximately 550 cfm (15.6 m<sup>3</sup>/min) per ring.

Table 6. Pile Specifications

Pile	Date Impact	Impact Start	Impact Stop	Number of Pile Strikes	Impact Hammer Used	Date Vibe	Hammer Used	Diameter	Thickness	Length (ft)	Depth of Embedment (ft)	Depth of Water (ft)	Latitude (deg. N)	Longitude (deg. W)
TP1	10/8/2011	15:04	15:17	98	D-100	10/5/2011	APE 600	36	3/4"	175	63.5 (5' soft)	80	47.75378056	122.7247
TP2	9/17/2011	10:26	10:30	15	D-100	9/10/2011	APE 600	36	3/4"	182	63	85	47.75229444	122.7248139
TP3	9/16/2011	16:10	16:16	33	D-100	8/30/2011	APE 600	36	1"	147	55	75	47.751975	122.7246306
TP4	10/3/2011	16:43	16:49	17	D-100	9/23/2011	APE 600	36	3/4"	197	63 (5' soft)	90	47.75194167	122.7251417
TP5	9/30/2011	13:36	13:45	67	D-100	9/23/2011	APE 600	48	1"	197	62 (16' soft)	100	47.75159444	122.7257306
TP6	10/3/2011	12:03	12:09	25	D-100	9/23/2011	APE 600	48	1"	182	63 (5' soft)	95	47.75154722	122.7252472
TP7	9/10/2011	16:36	16:57	87	D-100	8/30/2011	APE 600	36	3/4"	172	60	75	47.75126667	122.7248056
TP8	9/26/2011	9:29	9:40	25	D-100	9/22/2011	APE 600	36	3/4"	187	71 (13' soft)	90	47.75125	122.7255528
TP9	10/1/2011	16:30	16:34	63	D-100	9/21/2011	APE 600	36	3/4"	192	62 (16' soft)	95	47.75082778	122.7259083
TP10	9/24/2011	14:04	14:12	17	D-100	9/21/2011	APE 600	36	3/4"	182	64 (14' soft)	90	47.75057778	122.725725
TP11	9/29/2011	15:03	15:18	71	D-100	9/22/2011	APE 600	48	1"	177	62 (12' soft)	90	47.75036389	122.7258806
TP12	9/29/2011	10:18	10:23	26	D-100	8/31/2011	APE 600	36	3/4"	182	56	85	47.75030833	122.7253722
TP13	9/30/2011	9:51	9:56	13	D-100	8/31/2011	APE 600	48	1"	182	56	80	47.75029167	122.7252222
TTP1	9/1/2011	11:29	11:36	10	D-80	8/29/2011	APE 400	24	5/8"	117	58	20	47.75289722	122.7229222
TTP2	9/1/2011	15:40	15:51	78	D-80	8/29/2011	APE 600	36	1"	152	50	55	47.75254167	122.7239
TTP3	9/21/2011	10:10	10:20	30	D-100	8/30/2011	400/600	36	3/4"	172	36	50	47.75135278	122.7239889
TTP4	10/4/2011	14:50	14:58	44	D-100	8/31/2011	APE 600	36	1"	152	44	55	47.75027222	122.7244528
TP3RP1	9/16/2011	10:47	10:54	30	D-100	9/10/2011	APE 600	36	5/8"	178			See TP3	
TP3RP2	9/16/2011	15:03	15:16	30	D-100	9/8/2011	APE 600	36	5/8"	178				
TP3RP3	9/15/2011	14:18	14:33	19	D-80	9/8/2011	APE 600	36	5/8"	173				
TP9RP1	10/1/2011	9:19	9:24	14	D-100	9/26/2011	APE 600	36	3/4"	187			See TP9	
TP9RP2	10/1/2011	11:27	11:30	14	D-100	9/29/2011	APE 600	36	3/4"	182				
TP9RP3	10/1/2011	14:07	14:11	18	D-100	9/24/2011	APE 600	36	3/4"	182				

## Section 3 Results

---

In general, underwater and airborne sound measurements collected at the construction barge, approximately 10-15 meters from the pile driving activity, provided the best acoustic data for construction, since it was the closest location to pile activity. However, sound measurements were taken in multiple locations inside and outside the WRA (Illingworth and Rodkin, 2012), and distances to various sound thresholds for marine mammals were calculated using data from all available sources. Only sound levels recorded at the 10 m location are presented in this report. For more detailed sound pressure level results please see Illingworth and Rodkin (2012). In some cases data was not available from the barge-based sound sensors because of equipment failure; in these cases, sound thresholds were calculated based on other sensors located inside and outside the WRA.

### Impact Pile Driving: Acoustic Results

**Table 7** provides the RMS sound pressure levels recorded at 10 meters and the maximum distance to each isopleth from each hydrophone location. The received RMS level was typically dependent on the distance to the pile and the air bubble curtain systems, but also varied from pile to pile. The air bubble curtain system used was tested seven times during the project (**Table 7**). Testing was conducted by driving the pile with an equal number of strikes with the system on followed by the system off. The sound attenuation system was off for less than 1 minute in duration for each test. The typical RMS per strike was 3 to 15 dB higher when the system was off, as measured near the pile at the construction barge. However, these levels varied considerably. Variation was observed across each test, and among pile sizes and water depths. There was a small sample size of data from which to assess the effectiveness of the bubble curtain. In particular, there was only data from one 24-inch pile and two 48-inch piles. The most tests (four) occurred with 36-inch diameter piles. The level of sound attenuation ranged from 6 to 15 dB with an average of 10.2 decibels for these sized piles (**Table 7**).

During the Test Pile Program, impact pile driving occurred on 23 piles over the course of 14 days. A total of 844 of the permitted 1500 strikes were utilized. The number of pile strikes per event ranged from 3 to 98 strikes. The duration of impact pile driving events was short. With the exception of one two-minute event, these events lasted less than one minute. Eleven of the events, including two of the air bubble curtain off tests, utilized 20 pile strikes or less. During the tests of the effectiveness of the bubble curtain, the number of unattenuated impact strikes per event ranged from 7 to 40 strikes.

Each monitoring position typically included measurements at two depths: 10 meters and about 30 meters, except in the WRA where water depth was less than 30 meters, and the hydrophone was placed at about 20 m depth. The maximum RMS level measured at each position was used to estimate the extent in distance of the RMS levels for the 160, 180, and 190 dB isopleths. **Table 7** depicts the 10 m acoustic recordings for all impact pile driving events and the distance to each of the isopleths when the sound attenuation system was on and off.

The distance to the 160 dB RMS isopleth varied considerably. When the 160 dB RMS level was within the measurements made at the WRA boat, then the distance was estimated using data from the barge and WRA boat. When the 160 dB RMS level extended beyond the WRA boat

**Table 7. Acoustic Results from Impact Pile Driving**

Event Description	Pile Coordinates		Time	Sensor	Received Sound Pressure Level at 10 m (dB RMS)		Distance to Isoleth (m)			Number of Pile Strikes	Bubble Curtain ON/OFF*	Approximate dB RMS/Strike Reduction
					Avg	Max	190	180	160‡			
<b>Date: 9/1/2011</b>												
TTP#1 = 24"	Lat.	47° 45.171'	11:30-11:34	Mid	173	173	<10	<10	<500	3	ON	6 to 7
	Long.	122° 43.359'		Down	174	174						
TTP#1 = 24"	Lat.	47° 45.171'	11:36-11:39	Mid	180	180	<10	10	500	7	OFF	-
	Long.	122° 43.359'		Down	180	180						
TTP#2 = 36"	Lat.	47° 45.151'	15:40-15:46	Mid	183	185	10	50	600 M & N 1,000 S	40	ON	7
	Long.	122° 43.425'		Down	189	191						
TTP#2 = 36"	Lat.	47° 45.151'	15:51-15:52	Mid	190	191	50	250	2,500 N 2,500 S	38	OFF	-
	Long.	122° 43.425'		Down	196	197						
<b>Date: 9/10/2011</b>												
TP#7 = 36"	Lat.	47° 45.071'	16:37-16:48	Mid	180	182	<10	20	700	47	ON	8 to 12
	Long.	122° 43.483'		Down	181	183						
TP#7 = 36"	Lat.	47° 45.071'	16:56-16:57	Mid	188	189	60	250	2,500 N 2,500 S	40	OFF	-
	Long.	122° 43.483'		Down	193	194						
<b>Date: 9/15/2011</b>												
TP#3 RP#3 = 36"	Lat.	47° 45.118'	14:18-14:25	Mid	174	176	<10	20	<500	9	ON	6 to 7
	Long.	122° 43.468'		Down	180	182						
TP#3 RP#3 = 36"	Lat.	47° 45.118'	14:27-14:34	Mid	180	181	10	50	1,000	10	OFF	-
	Long.	122° 43.468'		Down	187	188						
<b>Date: 9/16/2011</b>												
TP#3 RP#2 = 36"	Lat.	47° 45.118'	10:44-10:53	Mid	177	179	<10	10	<500	30	ON	12 to 15
	Long.	122° 43.468'		Down	172	174						
TP#3 RP#1 = 36"	Lat.	47° 45.118'	15:02-15:11	Mid	175	178	<10	<10	800	30	ON	14
	Long.	122° 43.468'		Down	173	175						
TP#3 = 36"	Lat.	47° 45.118'	16:10-16:16	Mid	189	190	10	150	1,600 N 1,800 S	33	OFF	-
	Long.	122° 43.468'		Down	187	188						

Event Description	Pile Coordinates		Time	Sensor	Received Sound Pressure Level at 10 m (dB RMS)		Distance to Isoleth (m)			Number of Pile Strikes	Bubble Curtain ON/OFF*	Approximate dB RMS/Strike Reduction
					Avg	Max	190	180	160‡			
<b>Date: 9/17/2011</b>												
TP#2 = 36"	Lat.	47° 45.134'	10:26-10:31	Mid	177	178	10	50	500	15	ON	-
	Long.	122° 43.485'		Down	186	188						
<b>Date: 9/21/2011</b>												
TTP#3 = 36"	Lat.	47° 45.077'	10:09-10:20	Mid	190	192	20	200	600 M & N 950 S	30	ON	-
	Long.	122° 43.428'		Down	176	177						
<b>Date: 9/24/2011</b>												
TP#10 = 36"	Lat.	47° 45.032'	14:05-14:12	Mid	174	176	<10	20	<500	17	ON	-
	Long.	122° 43.540'		Down	181	182						
<b>Date: 9/26/2011</b>												
TP#8 = 36"	Lat.	47° 45.069'	9:31-9:41	Mid	177	180	10	150	1000 N 500 M	25	ON	-
	Long.	122° 43.531'		Down	189	191						
<b>Date: 9/29/2011</b>												
TP#12 = 36"	Lat.	47° 45.012'	10:18-10:23	Mid	179	183	10	50	600 M & N 500 S	26	ON	-
	Long.	122° 43.520'		Down	188	191						
TP#11 = 48"	Lat.	47° 45.014'	15:03-15:11	Mid	181	182	20	100	3,500 N 3,000 M & S	38	ON	3 to 9
	Long.	122° 43.551'		Down	191	192						
TP#11 = 48"	Lat.	47° 45.014'	15:17-15:18	Mid	190	191	30	100	4,000 N 3,500 M & S	33	OFF	-
	Long.	122° 43.551'		Down	194	195						
<b>Date: 9/30/2011</b>												
TP#13 = 48"	Lat.	47° 45.010'	9:52-9:56	Mid	182	183	10	100	<500 N 900 S	13	ON	-
	Long.	122° 43.508'		Down	191	192						
TP#5 = 48"	Lat.	47° 45.091'	13:36-13:40	Mid	182	183	10	120	2,000 N 1,800 S	35	ON	4 to 9
	Long.	122° 43.545'		Down	189	190						
TP#5 = 48"	Lat.	47° 45.091'	13:43-13:44	Mid	191	193	30	300	5,000 N 3,000 S	32	OFF	-
	Long.	122° 43.545'		Down	193	194						

Event Description	Pile Coordinates		Time	Sensor	Received Sound Pressure Level at 10 m (dB RMS)		Distance to Isoleth (m)			Number of Pile Strikes	Bubble Curtain ON/OFF*	Approximate dB RMS/Strike Reduction
					Avg	Max	190	180	160‡			
<b>Date: 10/1/2011</b>												
TP#9 RP#3 = 36"	Lat.	47° 45.043'	9:19-9:24	Mid	N/A‡	N/A	20	100	500	18	ON	-
	Long.	122° 43.544'		Down	N/A	N/A						
TP#9 RP#2 = 36"	Lat.	47° 45.043'	11:27-11:31	Mid	N/A	N/A	20	70	500	14	ON	-
	Long.	122° 43.544'		Down	N/A	N/A						
TP#9 RP#1 = 36"	Lat.	47° 45.043'	14:07-14:12	Mid	N/A	N/A	20	70	500	14	ON	-
	Long.	122° 43.544'		Down	N/A	N/A						
TP#9 = 36"	Lat.	47° 45.043'	16:29-16:34	Mid	N/A	N/A	30	100	1,500	63	ON	-
	Long.	122° 43.544'		Down	N/A	N/A						
<b>Date: 10/3/2011</b>												
TP#6 = 48"	Lat.	47° 45.088'	12:04-12:11	Mid	187	189	10	120	1,600 N 1,500 S	25	ON	-
	Long.	122° 43.511'		Down	191	191						
TP#4 = 36"	Lat.	47° 45.113'	16:44-16:50	Mid	N/A	N/A	<10	10	500 N 900 M & S	17	ON	-
	Long.	122° 43.508'		Down	N/A	N/A						
<b>Date: 10/4/2011</b>												
TTP#4 = 36"	Lat.	47° 45.011'	14:49-14:59	Mid	N/A	N/A	<10	10	500	44	ON	-
	Long.	122° 43.455'		Down	N/A	N/A						
<b>Date: 10/8/2011</b>												
TP#1 = 36"	Lat.	47° 45.228'	15:04-15:17	Mid	N/A	N/A	<10	20	900	98	ON	-
	Long.	122° 43.483'		Down	N/A	N/A						

‡ Recordings made at the barge from 10/1-10/8 (with the exception of 10/3) were contaminated, and impact RMS levels could not be calculated from these data

† Two vessel-based hydrophones were sometimes stationed in Hood Canal north and south of the construction area. In these cases, two estimates of the 160 dB distance were calculated

\* There was a total of 7 on/off tests, not 8, since one on/off test was performed on two different piles (TP#3/ TP#3 RP#1)

(typically 100 to 200 meters from the pile), data from the WRA boat and Mid, North, or South channel boats (typically around 600 to 1,000 meters) were used in the computations. Data from the Toandos raft was also used to represent Mid Channel conditions. The Toandos raft was fixed at about 2,400 meters across the Mid channel from all of the pile driving events.

Using data collected by the SLMs during the project, it was estimated that when the air bubble curtain system was operating, the distance to the 160 dB isopleth ranged from <500 meters to 3,500 m (**Table 7**). The variation in the distance to the 160 dB RMS isopleth was likely influenced by differences in pile sizes, the depth and type of the substrate, and variations in bubble curtain performance. Modeling used in the TPP environmental compliance documents using the practical spreading model predicted a distance to the 160 dB isopleth with the use of sound attenuation devices of 464 meters. Of the 23 impact pile driving events, there were 13 where the maximum 160-dB levels (at any recording position) extended beyond 500 m while the bubble curtain was operating. During all but two of these events, the piles were driven in 75 feet of water or greater. In nine of the 13 events, the distance to the 160 dB RMS isopleth was within 1,000 meters. In fact, of these nine events, during four of the drives hydrophones at least one location delineated the 160 dB RMS isopleth within 500 meters, but other locations had it extending beyond 500 meters, but within 1,000 meters. Of the 4 events during which the 160 dB RMS isopleth extended beyond 1,000 meters all were within 2,000 meters with the exception of one event in which the distance to the 160 dB RMS isopleth extended out to 3.5 km. Of these four events, three of the piles were 48-inches and one was 36-inches in diameter, and all were driven in deepest waters at the project site in water depths between 90-100 feet. There were eight marine mammal Level B takes (in all cases harbor seals) that occurred within the 160 dB harassment zone as calculated on a per-pile basis (**Appendix G**).

When the air bubble curtain system was turned off, the range to the 160 dB isopleth varied between 500 to 5,000 meters. Overall, the relatively large range in the distance to the 160 dB isopleth was likely influenced by differences in pile size, the depth and type of the substrate, and variations in air bubble curtain system performance. Modeling used in the TPP environmental compliance documents using the practical spreading model predicted a distance to the 160 dB RMS isopleth without the use of sound attenuation devices of 2,154 meters. During the one bubble curtain off test on the 24 inch pile the distance to the 160 dB RMS isopleth was only 500 meters. During bubble curtain off tests with the 36 inch piles, the distance to the 160 dB RMS isopleth ranged from 1,000 to 2,500 meters. Three of the four tests were below the modeled 160 dB RMS isopleth while the fourth was within a few hundred meters. During the two bubble curtain off tests with the 48 inch piles, the distance to the 160 dB RMS isopleth ranged from 3,000 to 5,000 meters. It should be kept in mind, however, that measurements for impact pile driving were made at 2.4 km or closer (most made at 1 km or closer), so the 160 dB isopleth was extrapolated using a practical spreading formula beyond this distance. As a result, the distance to the 160 dB RMS isopleth for some of the tests may actually be slightly closer than that calculated and depicted in **Table 7** since overall spreading loss within the project area exceeded the practical spreading loss.

**Table 8** summarizes the acoustic modeling results from impact pile driving obtained during the Test Pile Program by pile size. As indicated in the table below the average distance to the 160 dB isopleth across all 24 and 36 inch piles was within the model predicted distance when the bubble curtain was in operation or turned off. The average distance to the 160 dB RMS isopleth for all 48-inch piles exceeded the model predicted distance by between 596 – 836 meters (depending on the hydrophone position) when the bubble curtain was in operation, and by 711 – 2401 meters (depending on hydrophone position) when the bubble curtain was off.

**Table 8. Distances to RMS Sound Level Thresholds From Impact Pile Driving**

Activity	Distance (meters)					
	Deep			Mid-Depth		
Threshold (dB RMS)	190	180	160	190	180	160
24" Bubble Rings On	<10	<10	125	<10	<10	90
24" Bubble Rings Off	<10	<10	250	<10	10	315
36" Bubble Rings On	<10	35	425	<10	20	370
36" Bubble Rings Off	17	70	1,020	10	45	920
48" Bubble Rings On	15	60	1,300	<10	20	1,060
48" Bubble Rings Off	20	120	4,555	<10	65	2,865
<b>Predicted Distance (m) with Bubble Curtain On</b>	<b>5</b>	<b>22</b>	<b>464</b>	<b>5</b>	<b>22</b>	<b>464</b>
<b>Predicted Distance (m) with Bubble Curtain Off</b>	<b>22</b>	<b>100</b>	<b>2154</b>	<b>22</b>	<b>100</b>	<b>2154</b>

The distance to the maximum RMS level of 180 dB, the injury zone for cetaceans, ranged from < 10 to 200 meters (**Table 7**) but typically extended out to approximately 60 meters when the air bubble curtain system was operating. The 180-dB level did not extend beyond 20 m for 9 of the drives (**Table 7**). As depicted in **Table 8** the average distance to the 180 dB isopleth was within the model predicted distance for 24 inch piles, but was exceeded slightly during the impact pile driving of 36 and 48 inch piles when the bubble curtain was in operation. When the air bubble curtain system was not in operation during , the maximum 180-dB RMS level extended from 10 to 300 m but typically extended out to approximately 150 -160 meters. While these distances are larger than those predicted in the Navy's environmental compliance documents by the practical spreading loss model, the enlarged injury zones did not result in any unauthorized cetacean takes. No cetacean species were sighted within the water restricted area (WRA) at NBK at Bangor, including during all marine mammal monitoring associated with the TPP. The WRA fence extends 500-700 meters from the shoreline, well beyond the farthest distance to the 180 dB threshold when the air bubble curtain was off. The distance to the maximum level of 190 dB RMS ranged between < 10 to 30 meters across all piles (**Table 7**), but typically extended out to less than 10 meters for the majority of piles. The distance to the 190 dB RMS isopleths only exceeded 10 meters in six instances, five times it extended to 20 meters and once it extended to 30 m from the pile when the air bubble curtain system was operating (**Table 7**). As depicted in **Table 8**, the average distance to the 190 dB RMS isopleths was within the predicted levels when the bubble curtain was operating for 24 and 36 inch piles, and extended 10 meters over the predicted zone for 48 inch piles. When the air bubble curtain was not operating, the maximum



distance to the 190-dB RMS level extended from  $< 10$  to 60 from the pile (**Table 7**). The distance to the 190 dB RMS isopleths exceeded 30 meters during only two pile driving events when it extended out to 50 and 60 meters when the bubble curtain was off. While these distances are slightly larger than those predicted in the Navy's environmental compliance documents by the practical spreading loss model, the enlarged injury zones did not result in unauthorized takes of any pinnipeds. In fact, sound pressure levels were within the monitored shutdown zone during both attenuated and unattenuated impact pile driving at all times, with the exception of one unattenuated testing event of a 36-inch pile on 9/10/11 which lasted less than one minute in duration. During the testing of the bubble curtain on 9/10/11 which occurred at 14:56-14:57, no marine mammals were observed within over an hour of the testing event (the last marine mammal sighting on 9/10/11 occurred at 13:28). Air bubble curtain on-off tests during the TPP may not have been effective at assessing the air bubble curtain performance. This is because the tests were generally quite short (i.e., 10 or fewer strikes), and because the on and off conditions were sometimes conducted for different piles. There were only three tests where the same pile was tested with bubbles on and off, with a sufficient number of pile strikes to detect a sound reduction range: those were on September 1, September 10, and September 26 (**Table 7**). The test on September 16 reported curtain "on" sound levels for one pile, and curtain "off" sound levels for a different pile.

Ideally, pile-specific *predicted* unattenuated sound levels should also be compared with actual curtain "on" sound levels (rather than curtain "off" levels) to test the efficacy of air bubble curtains in sound attenuation. For example, piles that do not generate high levels of sound energy (and that are "quiet" to begin with) are not expected to show a significant reduction in noise with the use of a bubble curtain.

### **Vibratory Pile Driving: Acoustic Results**

Typical vibratory pile driving during the TPP resulted in sound levels that varied considerably through the driving periods. Vibratory sounds underwater were characterized by the measurement of RMS sound pressure levels. During the TPP there were 29 piles that were installed and removed using a vibratory hammer. During the installation/removal of an individual pile there were occasionally multiple vibratory recording events as a result of the pile driver being temporarily shutdown or the pile requiring additional driving at a later time to get proper loading. In total, 67 vibratory driving events (i.e., installation or removal of piles) were measured. The permitted duration of vibratory driving events was 1 hour per pile (USFWS 2011). Actual vibratory pile driving events during the TPP lasted from 4 to 26 minutes. The duration of vibratory extraction events ranged from 3.5 to 21.5 minutes per pile, and 30 minutes were permitted per pile extraction event (USFWS 2011). **Table 9** presents a summary of the average RMS sound pressure levels measured near the source (at 10 meters) and the estimated distance to the 120 dB behavioral harassment threshold for cetaceans and pinnipeds. On average, the near source level (at 10 meters) was 159 dB RMS (re: 1  $\mu$ Pa) for 36-inch diameter piles and 161 dB RMS (re: 1  $\mu$ Pa) for 48-inch diameter piles. The maximum event level from all vibratory driving was 172 dB RMS (re: 1  $\mu$ Pa). For environmental compliance documents for the TPP, the near-source level used for consultations was 180 dB RMS (re 1  $\mu$ Pa) at 10 meters. Based on the data recorded during the TPP, the source levels used during the consultation process were overly conservative. Both the average and maximum sound levels generated by vibratory pile driving did not exceed 180 dB at distances equal or further than 10 meters from the pile.

Prior to the TPP, the 120-dB behavioral disturbance zone for vibratory driving sounds was predicted to extend out along the main channel about 13,600 meters north to Squamish Harbor and about 6,800 meters south to Toandos Peninsula. Levels exceeding 120 dB were measured at distances out to 5,500 meters, where the level was 123 dB. However, there were measurements closer than 5,000 meters where sound levels did not exceed 120 dB. Attempts were made to measure at distances of 7,000 to 8,000 meters; however, vibratory sound levels were not audible during those measurements. The data collected during the TPP cannot accurately pinpoint a single distance which would estimate the extent of the 120-dB harassment zone, because of the large variability in measured sounds from drive to drive. The data do, however, indicate that levels *were not louder than those predicted for the project*. Although most measurements were made within the zone predicted to have levels above 120 dB, the measurements made outside of the zone had levels less than 120 dB. Using the average near source level and the average propagation rates from measured vibratory sound levels, the distance to the 120-dB zone was 3,505 to 7,500 meters (**Table 9**). Sound levels during soft starts were typically lower than those levels at the initiation and completion of continuous vibratory driving. However, levels during continuous driving varied considerably and were at times lower than those produced during the soft starts. It is difficult to assign a level that describes how much lower the soft start sound levels were than continuous levels.

An air bubble curtain was used during the vibratory removal of pile TP#2 and the vibratory installation of pile TP#3 MP#1 (both 36-inch piles) on 17 September 2011. The APE 600 vibratory hammer was used to install and remove the piles. Because there was no direct comparison of measured sound levels for any one pile with the bubble curtain on and the bubble curtain off, and since sound levels varied considerably during vibratory pile driving, it was not possible to assess air bubble curtain performance with an on and off test. However, a review of the data indicated that the bubble curtain provided an estimated 9 dB of reduction during the removal of the pile and 4 to 6 dB of reduction during the driving of the pile. **Table 10** summarizes the difference between the modeled and actual harassment sound thresholds for impact and vibratory pile driving.

## Airborne Sound

Concurrently with impact and vibratory measurements, airborne measurements were taken at four locations: two microphones were placed along the shoreline on the north and south borders of the WRA; and two microphones were placed on vessels within the WRA. No injury thresholds exist for marine mammals exposed to airborne sound, and no behavioral harassment threshold exists for cetaceans exposed to airborne sound. The behavioral harassment thresholds for pinnipeds are 90 dB (harbor seals only) and 100 dB (all other pinnipeds).

Summaries of near source levels for impact driving (RMS  $L_{max}$  levels) and associated airborne threshold distances are shown in **Table 11**. Prior to the TPP, the distance to the 100 dB harassment zone for pinnipeds (except harbor seals) was predicted to extend 113 m for both the 36- and 48-inch diameter piles. Based on the measurement of average unweighted RMS  $L_{max}$  levels and applying a  $20 \text{ Log}_{10}$  propagation rate, the zone extended 60 meters from the pile for 36-inch diameter piles and 45 m for 48-inch diameter piles. Prior to the TPP, the distance to the 90 dB harassment zone for harbor seals was predicted to extend 358 meters for harbor seals for both 36- and 48-inch diameter piles. Based on the measurement of average unweighted RMS  $L_{max}$  levels and a  $20 \text{ Log}_{10}$  propagation rate, the zone was 190 m for 36-inch diameter piles and 130 m from the 48-inch diameter piles.

**Table 9. Summary of Sound Levels During Vibratory Pile Installation and Removal**

Event Description	Pile Coordinates		Time	Sensor	Received Sound Pressure Level at 10 m (dB RMS)		Calculated distance (m) to 120 dB RMS to the North	Calculated distance (m) to 120 dB RMS to the South
					Avg	Max		
<b>Date: 8/29/2011</b>								
TTP#1 = 24"	Lat.	47° 45.171'	12:10:13-12:21:42	Mid			1,200	1,200
	Long.	122° 43.359'		Down	159	168		
TTP#2 = 36"	Lat.	47° 45.151'	15:06:33-15:20:21	Mid			450	3,500
	Long.	122° 43.425'		Down	169	174		
<b>Date: 8/30/2011</b>								
TTP#3 = 36"	Lat.	47° 45.077'	9:53:27-10:13:28	Mid	168	173	500	±7,000 (land)
	Long.	122° 43.428'		Down	168	174		
TTP#3 = 36"	Lat.	47° 45.077'	10:42:36-10:48:25	Mid	165	168	600	-
	Long.	122° 43.428'		Down	166	168		
TP#3 = 36"	Lat.	47° 45.116'	13:11:17-13:20:10	Mid	166	179		
	Long.	122° 43.473'		Down	167	180**		
TP#7 = 36"	Lat.	47° 45.071'	14:39:48-14:55:48	Mid	162	174	5,500	-
	Long.	122° 43.483'		Down				
<b>Date: 8/31/2011</b>								
TTP#4 = 36"	Lat.	47° 45.011'	9:19:02-9:25:35	Mid	167	172	<11,400	±7,000 (land)
	Long.	122° 43.455'		Down	166	172		
TTP#4 = 36"	Lat.	47° 45.011'	9:40:35-9:57:01	Mid	168	174	5,500	±7,000 (land)
	Long.	122° 43.455'		Down	169	174		
TP#13 = 48"	Lat.	47° 45.010'	11:59:01-12:10:27	Mid	171	178	19,800	±7,000 (land)
	Long.	122° 43.508'		Down	172	179		
TP#12 = 36"	Lat.	47° 45.012'	14:23:00-14:31:00	Mid	163	170	±13,500 (land)	±7,000 (land)
	Long.	122° 43.520'		Down	168	176		
<b>Date: 9/8/2011</b>								
TP#3 RP#3 = 36"	Lat.	47° 45.118'	14:34:08-15:06:46	Mid	158	173	2,500	3,000
	Long.	122° 43.468'		Down				
TP#3 RP#2 = 36"	Lat.	47° 45.118'	16:16:34-16:32:06	Mid	163	171	8,800	5,900
	Long.	122° 43.468'		Down				
TP#3 RP#2 = 36"	Lat.	47° 45.118'	16:46:08-16:57:34	Mid	158	173	2,800	4,000
	Long.	122° 43.468'		Down				
<b>Date: 9/10/2011</b>								
TP#3 RP#1 = 36"	Lat.	47° 45.118'	10:45:51-11:00:20	Mid	161	170	<12,100	±7,000 (land)
	Long.	122° 43.468'		Down	163	173		
TP#2 = 36"	Lat.	47° 45.134'	12:54:52-13:05:03	Mid	162	169	<2,500	<3,000
	Long.	122° 43.485'		Down	164	171		
<b>Date: 9/17/2011</b>								
TP#2 = 36"	Lat.	47° 45.134'	11:21:07-11:38:04	Mid	153	168	3,400	3,400
	Long.	122° 43.485'		Down	157	168		
TP#3 MP#1 = 36"	Lat.	47° 45.120'	12:24:06-12:35:27	Mid	153	160	4,200	4,200
	Long.	122° 43.466'		Down				

Event Description	Pile Coordinates		Time	Sensor	Received Sound Pressure Level at 10 m (dB RMS)		Calculated distance (m) to 120 dB RMS to the North	Calculated distance (m) to 120 dB RMS to the South
					Avg	Max		
<b>Date: 9/17/2011 (continued)</b>								
TTP#2 = 36"	Lat.	47° 45.151'	14:04:48- 14:24:05	Mid	162	173	±13,500 (land)	±7,000 (land)
	Long.	122° 43.425'		Down	163	172		
TP#3 MP#3 = 36"	Lat.	47° 45.119'	14:51:28- 15:03:41	Mid	157	169	7,000	7,000
	Long.	122° 43.480'		Down	159	170		
TP#7 = 36"	Lat.	47° 45.071'	15:25:21- 15:40:16	Mid	162	179	10,800	6,600
	Long.	122° 43.483'		Down	162	176		
TP#3 MP#2 = 36"	Lat.	47° 45.113'	16:09:26- 16:17:20	Mid	159	169	±13,500 (land)	4,100
	Long.	122° 43.469'		Down	159	168		
<b>Date: 9/21/2011</b>								
TP#10 = 36"	Lat.	47° 45.032'	13:38:53- 13:48:06	Mid	156	172	9,000	3,500
	Long.	122° 43.540'		Down	154	171		
TP#10 = 36"	Lat.	47° 45.032'	15:01:19- 15:14:35	Mid	159	168	6,100	±7,000 (land)
	Long.	122° 43.540'		Down	156	167		
TP#9 = 36"	Lat.	47° 45.043'	16:47:16- 17:00:12	Mid	162	166	9,200	±7,000 (land)
	Long.	122° 43.544'		Down	159	165		
<b>Date: 9/22/2011</b>								
TP#8 = 36"	Lat.	47° 45.069'	9:08:23- 9:29:36	Mid	156	166	5,800	5,800
	Long.	122° 43.531'		Down	159	169		
TP#11 = 48"	Lat.	47° 45.014'	15:18:20- 15:31:25	Mid	161	170	11,200	±7,000 (land)
	Long.	122° 43.551'		Down	164	173		
<b>Date: 9/23/2011</b>								
TP#6 = 48"	Lat.	47° 45.088'	8:54:48- 9:08:56	Mid	161	176	11,700	6,300
	Long.	122° 43.511'		Down	163	176		
TP#5 = 48"	Lat.	47° 45.091'	11:21:56- 11:39:51	Mid	161	175	8,400	±7,000 (land)
	Long.	122° 43.545'		Down	165	174		
TP#4, Batter = 36"	Lat.	47° 45.113'	15:36:58- 16:15:20	Mid	163	175	6,000	6,000
	Long.	122° 43.507'		Down	162	175		
<b>Date: 9/24/2011</b>								
TP#10 = 36"	Lat.	47° 45.032'	14:46:28- 15:01:00	Mid	149	165	1,700	2,400
	Long.	122° 43.540'		Down	152	165		
TP#9 RP#3 = 36"	Lat.	47° 45.043'	15:59:38- 16:14:19	Mid	154	166	2,200	2,800
	Long.	122° 43.544'		Down	155	166		
<b>Date: 9/26/2011</b>								
TP#8 = 36"	Lat.	47° 45.069'	10:25:57- 10:47:39	Mid	161	174	6,800	±7,000 (land)
	Long.	122° 43.531'		Down	162	174		
TP#9 RP#1 = 36"	Lat.	47° 45.043'	11:16:20- 11:30:41	Mid	161	170	8,000	±7,000 (land)
	Long.	122° 43.544'		Down	162	171		
<b>Date: 9/29/2011</b>								
TP#12 = 36"	Lat.	47° 45.012'	11:17- 11:29	Mid				
	Long.	122° 43.520'		Down				
TP#9 RP#2 = 36"	Lat.	47° 45.043'	12:09:31- 12:18:50	Mid	156	166	3,800	3,700
	Long.	122° 43.544'		Down	157	165		

Event Description	Pile Coordinates		Time	Sensor	Received Sound Pressure Level at 10 m (dB RMS)		Calculated distance (m) to 120 dB RMS to the North	Calculated distance (m) to 120 dB RMS to the South
					Avg	Max		
<b>Date: 9/29/2011 (continued)</b>								
TP#11 = 48"	Lat.	47° 45.014'	16:27:16-16:43:42	Mid	149	166	1,000	1,000
	Long.	122° 43.551'		Down				
TP#9 MP#1 = 36"	Lat.	47° 45.043'	17:02:44-17:09:26	Mid	154	162	2,100	2,100
	Long.	122° 43.544'		Down	155	162		
<b>Date: 9/30/2011</b>								
TP#13 = 48"	Lat.	47° 45.010'	10:39:49-10:55:35	Mid	160	178	2,700	3,300
	Long.	122° 43.508'		Down	161	176		
TP#9 MP#2 = 36"	Lat.	47° 45.041'	11:29:35-11:39:19	Mid	161	174	2,500	3,200
	Long.	122° 43.563'		Down	162	173		
TP#5 = 48"	Lat.	47° 45.091'	14:23:19-14:47:04	Mid	161	176	6,300	±7,000 (land)
	Long.	122° 43.545'		Down	162	174		
TP#9 MP#3 = 36"	Lat.	47° 45.053'	15:11:05-15:16:14	Mid	166	177	4,600	4,600
	Long.	122° 43.557'		Down	167	175		
<b>Date: 10/3/2011</b>								
TP#6 = 48"	Lat.	47° 45.088'	13:58:49-14:17:22	Mid	152	165	2,000	2,000
	Long.	122° 43.511'		Down	154	169		
TP#4 = 36"	Lat.	47° 45.113'	17:50:23-18:04:08	Mid	158	172	3,700	3,700
	Long.	122° 43.508'		Down	159	171		
Event Description	Pile Coordinates		Time	Sensor	Received Sound Pressure Level at 10 m		Calculated distance (m) to 120 dB RMS	
					Avg	Max		
<b>Date: 10/4/2011</b>								
TP#4 = 36"	Lat.	47° 45.113'	10:43:06-11:09:20	Mid	157	172	4,900	
	Long.	122° 43.508'		Down	159	175		
TTP#1 = 24"	Lat.	47° 45.171'	15:48:31-16:08:10	Mid	157	166	5,500	
	Long.	122° 43.359'		Down	160	167		
<b>Date: 10/5/2011</b>								
TP#1 = 36"	Lat.	47° 45.228'	16:25:04-16:52:25	Mid			3,500	
	Long.	122° 43.483'		Down				
<b>Date: 10/8/2011</b>								
TP#1 = 36"	Lat.	47° 45.228'	16:06:48-16:20:27	Mid	160	178	±7,000 (land)	
	Long.	122° 43.483'		Down	161	176		
<b>Date: 10/17/2011</b>								
TP#3 MP#3 = 36"	Lat.	47° 45.119'	12:57:55-13:07:01	Mid	151	164	4,200	
	Long.	122° 43.480'		Down	152	164		
TP#3 MP#2 = 36"	Lat.	47° 45.113'	15:16:43-15:25:32	Mid	155	167	4,800	
	Long.	122° 43.469'		Down	153	167		
TP#3 = 36"	Lat.	47° 45.116'	16:12:49-16:20:32	Mid	155	167	±7,000 (land)	
	Long.	122° 43.473'		Down	156	167		

Event Description	Pile Coordinates		Time	Sensor	Received Sound Pressure Level at 10 m		Calculated distance (m) to 120 dB RMS
					Avg	Max	
<b>Date: 10/18/2011</b>							
TP#3 RP#3 = 36"	Lat.	47° 45.118'	11:21:27-11:39:04	Mid	159	167	6,000
	Long.	122° 43.468'		Down	161	169	
TP#3 RP#1 = 36"	Lat.	47° 45.118'	14:13:46-14:30:03	Mid	158	170	6,200
	Long.	122° 43.468'		Down			
TP#3 RP#2 = 36"	Lat.	47° 45.118'	13:13:42-13:31:02	Mid	160	172	±7,000 (land)
	Long.	122° 43.468'		Down			
TP#3 MP#1 = 36"	Lat.	47° 45.120'	15:10:36-15:21:07	Mid	158	173	5,200
	Long.	122° 43.466'		Down			
<b>Date: 10/19/2011</b>							
TP#9 MP#2 = 36"	Lat.	47° 45.041'	8:31:48-8:37:15	Mid	154	156	1,400
	Long.	122° 43.563'		Down	154	156	
TP#9 MP#2 = 36"	Lat.	47° 45.041'	10:18:36-10:56:03	Mid	152	171	1,900
	Long.	122° 43.563'		Down	154	175	
TP#9 MP#3 = 36"	Lat.	47° 45.053'	13:28:04-13:40:01	Mid	151	169	1,700
	Long.	122° 43.557'		Down	154	169	
TP#9 MP#1 = 36"	Lat.	47° 45.043'	14:30:42-14:40:00	Mid	149	162	1,700
	Long.	122° 43.544'		Down	150	163	
TP#9 = 36"	Lat.	47° 45.043'	15:51:37-16:12:33	Mid	158	176	6,000
	Long.	122° 43.544'		Down	159	175	
<b>Date: 10/20/2011</b>							
TP#9 RP#3 = 36"	Lat.	47° 45.043'	8:41:08-8:55:53	Mid	149	161	2,500
	Long.	122° 43.544'		Down	148	161	
TP#9 RP#1 = 36"	Lat.	47° 45.043'	10:46:25-11:02:20	Mid	153	162	5,100
	Long.	122° 43.544'		Down	154	166	
TP#9 RP#2 = 36"	Lat.	47° 45.043'	11:42:12-11:55:24	Mid	151	163	1,100
	Long.	122° 43.544'		Down	152	166	
TTP#4 = 36"	Lat.	47° 45.011'	13:29:21-13:39:45	Mid			±7,000 (land)
	Long.	122° 43.455'		Down	164	171	
TTP#4 = 36"	Lat.	47° 45.011'	14:03:24-14:13:43	Mid			±7,000 (land)
	Long.	122° 43.455'		Down	167	173	
TTP#3 = 36"	Lat.	47° 45.077'	15:22:42-15:36:16	Mid			5,400
	Long.	122° 43.428'		Down	161	171	

† Two vessel-based hydrophones were stationed in Hood Canal north and south of the construction area during Phase 1 of TPP; therefore, two estimates of the 120 dB distance were calculated

‡ Only one vessel-based hydrophone was placed in Hood Canal during Phase 2 of TPP; therefore, only one estimate of the 120 dB distance was calculated

\*Estimated distance to the 120 dB extended beyond the shores of Hood Canal

\*\*This was the maximum sound level recorded at 10 m throughout the TPP during vibratory driving.

**Table 10. Modeled and Measured Marine Mammal Behavioral Harassment RMS Sound Level Thresholds for Impact (160 dB) and Vibratory (120 dB) Pile Driving**

Threshold	Modeled Distance (Average, m)	Measured Distance (Average, m)
160 dB	2154 (464)*	1,569 (505)*
120 dB	10,200†	5,737

\*Number in parentheses represents distance with air bubble curtain operating

†Average of predicted thresholds to the North (13,600 m) and South (6,800 m) in Hood Canal

Note: Distances to thresholds are based on average maximum RMS levels measured for the project

Summaries of near source levels for vibratory driving (RMS  $L_{max}$  levels) and associated threshold distances are shown in **Table 12**. Prior to the TPP, the distance to the 100 dB (unweighted) harassment zone for vibratory pile driving was predicted to extend 9 meters from both the 36-inch and the 48-inch diameter piles. Based on the measurement of average RMS  $L_{eq}$  levels and applying a 20  $\text{Log}_{10}$  propagation rate, the zone extended 20 meters from the pile for 36-inch diameter piles and less than 15 m for 48-inch diameter piles. Prior to the TPP, the distance to the 90 dB harassment zone for harbor seals was predicted to extend 28 m from the pile. This would be for both the 36-inch and 48-inch diameter piles. Based on the measurement of average levels and applying a 20 $\text{Log}_{10}$  propagation rate, the zone was 60 m for the 36-inch diameter piles and 38 m for the 48-inch diameter piles. While these distances to the airborne behavioral harassment thresholds during the TPP were slightly larger than those originally modeled, there are no haulout areas within these distances and there were no airborne takings of any pinniped species during vibratory pile driving/removal as part of the TPP.

### Marine Mammal Sightings

There are six marine mammal (three cetacean and three pinniped) species which may inhabit or transit through the waters nearby NBK Bangor in the Hood Canal. Of these species, only four were observed in the waters near NBK at Bangor in the Hood Canal during the Test Pile Program: the California sea lion (*Zalophus californianus*), Steller sea lion (*Eumetopias jubatus*), harbor seal (*Phoca vitulina*), and harbor porpoise (*Phocoena phocoena*). The Steller sea lion is the only ESA-listed marine mammal that occurs in Hood Canal. All marine mammals sighted in the Hood Canal are regulated by NMFS.

More California sea lions were seen per sighting (average 7.2) than any other species (**Figure 9**). Mean, modal, maximum and minimum group sizes were also calculated for each species.

**All Sightings on Construction Days.** A total of 941 sightings of 1,665 individual marine mammals were observed during marine mammal surveys on construction days (Phase 1 and 2) of the TPP (**Table 13, Appendix H**). Observations include those made during pile driving activities, and those made during down time (non-construction periods) on work days. Four marine mammal species were identified: the harbor porpoise, harbor seal, California sea lion and Steller sea lion. Harbor seals were by far the most abundant of the four species (**Table 13**).

Table 11. Summary of Airborne Sound Levels During Impact Driving

Event Description	Pile Coordinates		Time	Sensor	Measured Sound Pressure Level (RMS) at 10 m		Calculated distance (m) to 100 dB RMS	Calculated distance (m) to 90 dB RMS
					Avg	Lmax		
<b>Date: 9/1/2011</b>								
TTP#1 = 24"	Lat.	47° 45.171'	11:29:45 11:37:16	Un-weighted	89	110	47	150
	Long.	122° 43.359'		A-weighted	85	109		
TTP#2 = 36"	Lat.	47° 45.151'	15:40:25 15:52:06	Un-weighted	96	112	60	189
	Long.	122° 43.425'		A-weighted	94	110		
<b>Date: 9/10/2011</b>								
TP#7 = 36"	Lat.	47° 45.071'	16:36:38 16:57:50	Un-weighted	***		***	***
	Long.	122° 43.483'		A-weighted				
<b>Date: 9/15/2011</b>								
TP#3 RP#3 = 36"	Lat.	47° 45.118'	14:18:04 14:34:05	Un-weighted	94	112	60	189
	Long.	122° 43.468'		A-weighted	90	110		
<b>Date: 9/16/2011</b>								
TP#3 RP#2 = 36"	Lat.	47° 45.118'	10:44:24 10:53:40	Un-weighted	***		75 <sup>†</sup>	238 <sup>†</sup>
	Long.	122° 43.468'		A-weighted				
TP#3 RP#1 = 36"	Lat.	47° 45.118'	15:02:45 15:10:58	Un-weighted	***		74 <sup>†</sup>	233 <sup>†</sup>
	Long.	122° 43.468'		A-weighted				
TP#3 = 36"	Lat.	47° 45.116'	16:10:39 16:16:37	Un-weighted	***		42 <sup>†</sup>	132 <sup>†</sup>
	Long.	122° 43.473'		A-weighted				
<b>Date: 9/17/2011</b>								
TP#2 = 36"	Lat.	47° 45.134'	10:26:20 10:31:14	Un-weighted	91	111	52	164
	Long.	122° 43.485'		A-weighted	88	108		
<b>Date: 9/21/2011</b>								
TTP#3 = 36"	Lat.	47° 45.077'	10:10:18 10:20:41	Un-weighted	91	111	52	164
	Long.	122° 43.428'		A-weighted	89	110		
<b>Date: 9/24/2011</b>								
TP#10 = 36"	Lat.	47° 45.032'	14:05:00 14:12:24	Un-weighted	89	107	32	103
	Long.	122° 43.540'		A-weighted	85	105		
<b>Date: 9/26/2011</b>								
TP#8 = 36"	Lat.	47° 45.069'	9:31:38 9:41:32	Un-weighted	89	106	29	92
	Long.	122° 43.531'		A-weighted	86	106		
<b>Date: 9/29/2011</b>								
TP#12 = 36"	Lat.	47° 45.012'	10:18:18 10:23:13	Un-weighted	91	106	20	63
	Long.	122° 43.520'		A-weighted	88	104		
TP#11 = 48"	Lat.	47° 45.014'	15:03:22 15:18:18	Un-weighted	90	106	30	95
	Long.	122° 43.551'		A-weighted	87	104		



Event Description	Pile Coordinates		Time	Sensor	Measured Sound Pressure Level (RMS) at 10 m		Calculated distance (m) to 100 dB RMS	Calculated distance (m) to 90 dB RMS
					Avg	Lmax		
<b>Date: 9/30/2011</b>								
TP#13 = 48"	Lat.	47° 45.010'	9:52:01	Un-weighted	88	106	30	94
	Long.	122° 43.508'	9:56:59	A-weighted	85	104		
TP#5 = 48"	Lat.	47° 45.091'	13:36:18	Un-weighted	93	109	42	134
	Long.	122° 43.545'	13:40:32	A-weighted	92	108		
<b>Date: 10/1/2011</b>								
TP#9 RP#3 - 36"	Lat.	47° 45.043'	9:19:11	Un-weighted	***		49 <sup>†</sup>	156 <sup>†</sup>
	Long.	122° 43.544'	9:24:05	A-weighted				
TP#9 RP#2 - 36"	Lat.	47° 45.043'	11:27:25	Un-weighted	***		54 <sup>†</sup>	172 <sup>†</sup>
	Long.	122° 43.544'	11:31:11	A-weighted				
TP#9 RP#1 - 36"	Lat.	47° 45.043'	14:07:50	Un-weighted	***		39 <sup>†</sup>	123 <sup>†</sup>
	Long.	122° 43.544'	14:12:00	A-weighted				
TP#9 = 36"	Lat.	47° 45.043'	16:29:13	Un-weighted	***		50 <sup>†</sup>	159 <sup>†</sup>
	Long.	122° 43.544'	16:34:06	A-weighted				
<b>Date: 10/3/2011</b>								
TP#6 = 48"	Lat.	47° 45.088'	12:04:52	Un-weighted	91	107	35	111
	Long.	122° 43.511'	12:11:04	A-weighted	86	105		
TP#4 = 36"	Lat.	47° 45.113'	16:44:45	Un-weighted	90	107	34	106
	Long.	122° 43.508'	16:50:15	A-weighted	87	105		
<b>Date: 10/4/2011</b>								
TTP#4 = 36"	Lat.	47° 45.011'	15:52:00	Un-weighted	93	108	39	123
	Long.	122° 43.455'	14:59:52	A-weighted	89	108		
<b>Date: 10/8/2011</b>								
TP#1 = 36"	Lat.	47° 45.228'	15:04:29	Un-weighted	***		Noise levels not from Pile driving	Noise levels not from Pile driving
	Long.	122° 43.483'	15:17:14	A-weighted				

\*\*\*No data available

<sup>†</sup>Isopleths calculated from shore-based microphones and WRA boat microphone only; no data available from 10 m (barge) microphone

Table 12. Summary of Airborne Sound Levels During Vibratory Driving

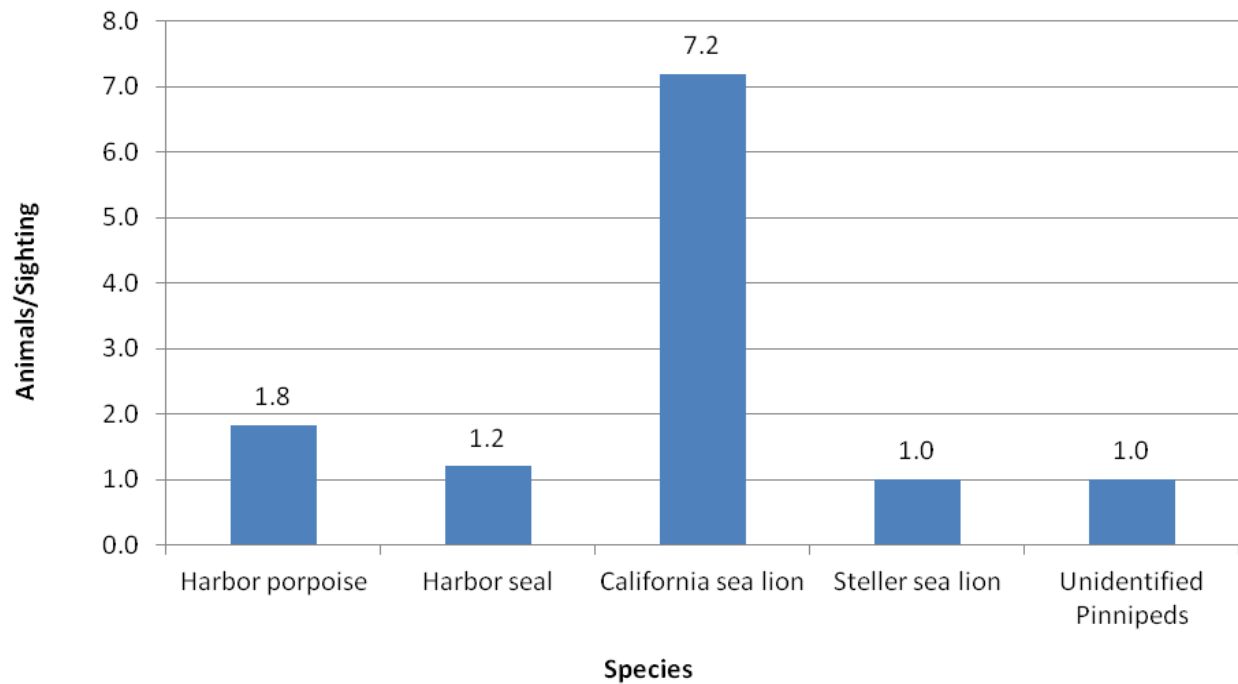
Event Description	Pile Coordinates		Time	Sensor	Measured Sound Pressure Level (RMS) at 10 m		Calculated distance (m) to 100 dB RMS	Calculated distance (m) to 90 dB RMS
					Avg	Max		
<b>Date: 8/29/2011</b>								
TTP#1 - 24"	Lat.	47° 45.171'	12:10:13-12:21:42	Un-weighted	92	102	19	60
	Long.	122° 43.359'		A-weighted	85	96		
TTP#2 - 36"	Lat.	47° 45.151'	15:06:33-15:20:21	Un-weighted	96	103	21	67
	Long.	122° 43.425'		A-weighted	89	98		
<b>Date: 8/30/2011</b>								
TTP#3 - 36"	Lat.	47° 45.077'	9:53:27-10:13:28	Un-weighted	102	108	38	119
	Long.	122° 43.428'		A-weighted	89	101		
TTP#3 - 36"	Lat.	47° 45.077'	10:42:36-10:48:25	Un-weighted	92	103	21	67
	Long.	122° 43.428'		A-weighted	86	92		
TP#3 - 36"	Lat.	47° 45.116'	13:11:17-13:20:10	Un-weighted	95	105	27	84
	Long.	122° 43.473'		A-weighted	89	101		
TP#7 - 36"	Lat.	47° 45.071'	14:39:48-14:55:48	Un-weighted	93	105	27	84
	Long.	122° 43.483'		A-weighted	88	102		
<b>Date: 8/31/2011</b>								
TTP#4 - 36"	Lat.	47° 45.011'	9:19:02-9:25:35	Un-weighted	95	103	20	64
	Long.	122° 43.455'		A-weighted	88	97		
TTP#4 - 36"	Lat.	47° 45.011'	9:40:35-9:57:01	Un-weighted	99	106	31	99
	Long.	122° 43.455'		A-weighted	89	95		
TP#13 - 48"	Lat.	47° 45.010'	11:59:01-12:10:27	Un-weighted	100	108	36	112
	Long.	122° 43.508'		A-weighted	93	101		
TP#12- 36"	Lat.	47° 45.012'	14:23:00-14:31:00	Un-weighted	96	104	25	79
	Long.	122° 43.520'		A-weighted	89	96		
<b>Date: 9/8/2011</b>								
TP#3 RP#3 - 36"	Lat.	47° 45.118'	14:34:08-15:06:46	Un-weighted	91	105	26	82
	Long.	122° 43.468'		A-weighted	86	101		
TP#3 RP#2 - 36"	Lat.	47° 45.118'	16:16:34-16:32:06	Un-weighted	91	100	16	49
	Long.	122° 43.468'		A-weighted	84	97		
TP#3 RP#2 - 36"	Lat.	47° 45.118'	16:46:08-16:57:34	Un-weighted	91	101	16	50
	Long.	122° 43.468'		A-weighted	85	95		
<b>Date: 9/10/2011</b>								
TP#3 RP#1 - 36"	Lat.	47° 45.118'	10:45:51-11:00:20	Un-weighted	***	***	***	***
	Long.	122° 43.468'		A-weighted	***	***		
TP#2 - 36"	Lat.	47° 45.134'	12:54:52-13:05:03	Un-weighted	***	***	***	***
	Long.	122° 43.485'		A-weighted	***	***		

Event Description	Pile Coordinates		Time	Sensor	Measured Sound Pressure Level (RMS) at 10 m		Calculated distance (m) to 100 dB RMS	Calculated distance (m) to 90 dB RMS
					Avg	Max		
<b>Date: 9/17/2011</b>								
TP#2 - 36"	Lat.	47° 45.134'	11:21:07-11:38:04	Un-weighted	90	98	12	39
	Long.	122° 43.485'		A-weighted	85	92		
TP#3 MP#1 - 36"	Lat.	47° 45.120'	12:24:06-12:35:27	Un-weighted	90	98	12	37
	Long.	122° 43.466'		A-weighted	81	89		
TTP#2 - 36"	Lat.	47° 45.151'	14:04:48-14:24:05	Un-weighted	92	100	15	46
	Long.	122° 43.425'		A-weighted	87	97		
TP#3 MP#3 - 36"	Lat.	47° 45.119'	14:51:28-15:03:41	Un-weighted	90	100	15	48
	Long.	122° 43.480'		A-weighted	83	95		
TP#7 - 36"	Lat.	47° 45.071'	15:25:21-15:40:16	Un-weighted	93	103	20	65
	Long.	122° 43.483'		A-weighted	89	100		
TP#3 MP#2 - 36"	Lat.	47° 45.113'	19:09:26-16:17:20	Un-weighted	91	101	17	53
	Long.	122° 43.469'		A-weighted	87	98		
<b>Date: 9/21/2011</b>								
TP#10 - 36"	Lat.	47° 45.032'	13:38:53-13:48:06	Un-weighted	95	105	26	81
	Long.	122° 43.540'		A-weighted	90	100		
TP#10 - 36"	Lat.	47° 45.032'	16:47:16-17:00:12	Un-weighted	94	104	22	71
	Long.	122° 43.540'		A-weighted	89	100		
TP#9 - 36"	Lat.	47° 45.043'	16:47:16-17:00:12	Un-weighted	94	104	24	74
	Long.	122° 43.544'		A-weighted	89	100		
<b>Date: 9/22/2011</b>								
TP#8 - 36"	Lat.	47° 45.069'	9:08:23-9:29:36	Un-weighted	94	102	19	59
	Long.	122° 43.531'		A-weighted	86	96		
TP#11 - 48"	Lat.	47° 45.014'	15:18:20-15:31:25	Un-weighted	93	104	24	76
	Long.	122° 43.551'		A-weighted	85	99		
<b>Date: 9/23/2011</b>								
TP#6 - 48"	Lat.	47° 45.088'	8:54:48-9:08:56	Un-weighted	96	103	21	65
	Long.	122° 43.511'		A-weighted	88	95		
TP#5 - 48"	Lat.	47° 45.091'	11:21:56-11:39:51	Un-weighted	98	107	32	101
	Long.	122° 43.545'		A-weighted	90	100		
TP#4, Batter - 36"	Lat.	47° 45.113'	15:36:58-16:15:20	Un-weighted	97	108	39	123
	Long.	122° 43.507'		A-weighted	89	100		
<b>Date: 9/24/2011</b>								
TP#10 - 36"	Lat.	47° 45.032'	14:46:28-15:01:00	Un-weighted	90	102	19	61
	Long.	122° 43.540'		A-weighted	83	98		
TP#9 RP#3 - 36"	Lat.	47° 45.043'	15:59:38-16:14:19	Un-weighted	91	101	16	50
	Long.	122° 43.544'		A-weighted	85	98		

Event Description	Pile Coordinates		Time	Sensor	Measured Sound Pressure Level (RMS) at 10 m		Calculated distance (m) to 100 dB RMS	Calculated distance (m) to 90 dB RMS
					Avg	Max		
<b>Date: 9/26/2011</b>								
TP#8 - 36"	Lat.	47° 45.069'	10:25:57-10:47:39	Un-weighted	92	100	16	49
	Long.	122° 43.531'		A-weighted	86	96		
TP#9 RP#1 - 36"	Lat.	47° 45.043'	11:16:20-11:30:41	Un-weighted	94	100	16	50
	Long.	122° 43.544'		A-weighted	92	99		
<b>Date: 9/29/2011</b>								
TP#12 - 36"	Lat.	47° 45.012'	11:14:00-11:29:35	Un-weighted	92	103	21	65
	Long.	122° 43.520'		A-weighted	84	98		
TP#9 RP#2 - 36"	Lat.	47° 45.043'	12:09:31-12:18:50	Un-weighted	93	105	25	80
	Long.	122° 43.544'		A-weighted	89	104		
TP#11 - 48"	Lat.	47° 45.014'	16:27:16-16:43:42	Un-weighted	91	102	18	58
	Long.	122° 43.551'		A-weighted	82	98		
TP#9 MP#1 - 36"	Lat.	47° 45.043'	17:02:44-17:09:26	Un-weighted	91	102	18	58
	Long.	122° 43.544'		A-weighted	81	97		
<b>Date: 9/30/2011</b>								
TP#13 - 48"	Lat.	47° 45.010'	10:39:49-10:55:35	Un-weighted	93	104	24	74
	Long.	122° 43.508'		A-weighted	86	98		
TP#9 MP#2 - 36"	Lat.	47° 45.041'	11:29:35-11:39:19	Un-weighted	93	100	16	49
	Long.	122° 43.563'		A-weighted	88	98		
TP#5 - 48"	Lat.	47° 45.091'	14:23:19-14:47:04	Un-weighted	94	104	24	74
	Long.	122° 43.545'		A-weighted	88	98		
TP#9 MP#3 - 36"	Lat.	47° 45.053'	15:11:05-15:16:14	Un-weighted	97	104	23	72
	Long.	122° 43.557'		A-weighted	92	100		
<b>Date: 10/3/2011</b>								
TP#6 - 48"	Lat.	47° 45.088'	13:58:49-14:17:22	Un-weighted	90	97	11	35
	Long.	122° 43.511'		A-weighted	82	89		
TP#4 - 36"	Lat.	47° 45.113'	17:50:23-18:04:08	Un-weighted	89	97	11	34
	Long.	122° 43.508'		A-weighted	80	92		
<b>Date: 10/4/2011</b>								
TP#4 - 36"	Lat.	47° 45.113'	10:43:06-11:09:20	Un-weighted	91	100	15	48
	Long.	122° 43.508'		A-weighted	85	97		
TTP#1 - 24"	Lat.	47° 45.171'	15:48:31-16:08:10	Un-weighted	90	96	9	30
	Long.	122° 43.359'		A-weighted	82	88		

\*\*\*No data available

^ No airborne data collected at 10 m after 10/4. Distances to 90 dB and 100 dB isopleths after this date were assumed to be the maximum recorded until this date (123 m and 139 m, respectively)



**Figure 9. Mean Number of Animals per Sighting (Phases 1 and 2)**

**Table 13. Total Number of Animals and Sightings by Species (Phases 1 & 2)**

Species	Total # Animals	Total # Sightings	Mean Group Size	Modal Group Size	Max Group Size	Min Group Size
Harbor porpoise	125	68	1.8	2	6	1
Harbor seal	941	782	1.2	1	29	1
California sea lion	590	82	7.2	1	31	1
Steller sea lion	6	6	1.0	1	1	1
Unidentified pinnipeds*	3	3	1.0	1	1	1
<b>TOTAL</b>	<b>1,665</b>	<b>941</b>	-	-	-	-

\*2 possible California sea lions, 1 probable harbor seal

During Phase 1, a total of 782 sightings of 1,207 individual marine mammals were observed (Table 14) during marine mammal surveys on construction days. Observations include those made during pile driving activities, and those made during non-construction periods. Sighting rates are reported by work phase, since effort level differed between phases. Sighting rates were calculated as follows:

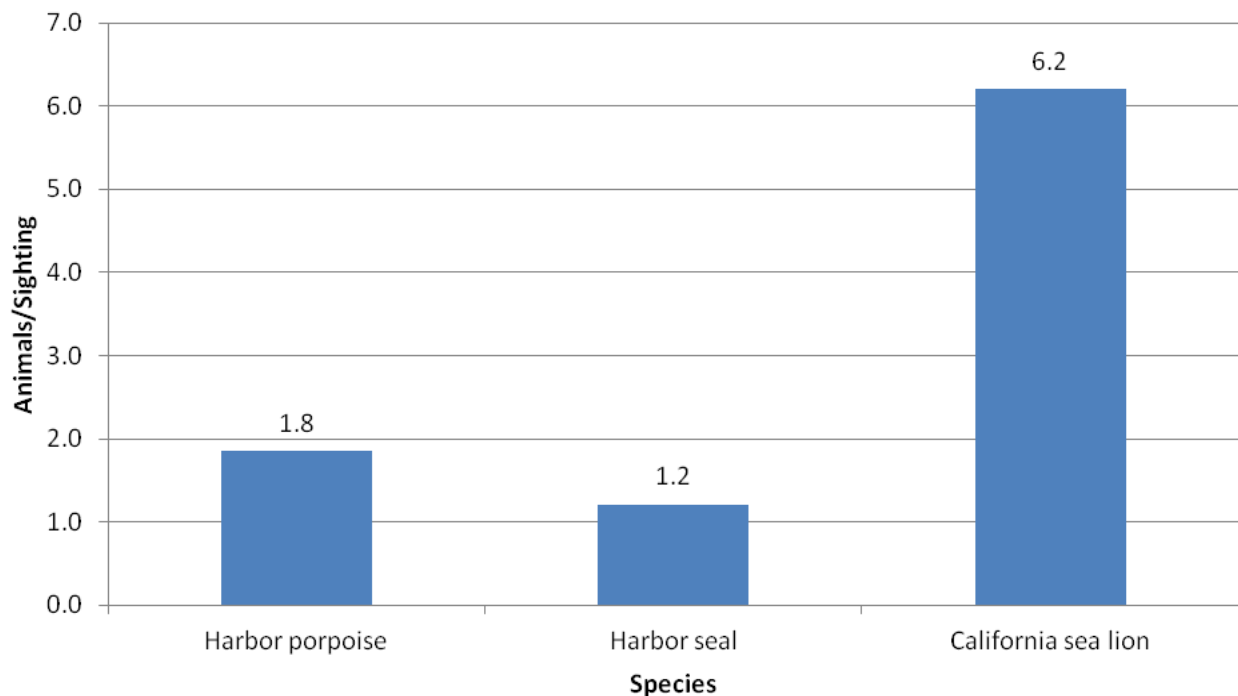
$$\text{Number of observer hours} = \text{Total number of survey hours} \times \text{Average number of observers}$$

$$\text{Sightings per observer hour} = \text{Sightings per species} / \text{Number of observer hours}$$

**Table 14. Total Number of Animals and Sightings by Species (Phase 1)**

Species	Total # Animals	Total # Sightings	Sightings Per Obs Hr	Mean Group Size	Modal Group Size	Max Group Size	Min Group Size
Harbor porpoise	122	66	0.07	1.8	2	6	1
Harbor seal	806	671	0.73	1.2	1	29	1
California sea lion	279	45	0.05	6.2	1	31	1
<b>TOTAL</b>	<b>1,207</b>	<b>782</b>	<b>0.85</b>	-	-	-	-

The total number of survey hours in TPP Phase 1 was 149.01, with an average of 6.2 observers participating in surveys during this time frame (29 August 2011 through 4 October 2011). Three marine mammal species were identified during Phase 1: the harbor porpoise, harbor seal, and California sea lion. Harbor seals were the most abundant of the three species, had the highest sighting rate (0.73 sightings per hour). On average, more California sea lions were observed per sighting (mean 6.2) than any other species (**Figure 10**). Although the modal group size of California sea lions was 1, the maximum group size was 31. Animals sometimes formed large group sizes when hauled out along the port security barrier (approximately 500 m to 700 m from the construction area) and at Delta Pier (approximately 1,160 m -1,500 m from the construction area, **Figure 12**).

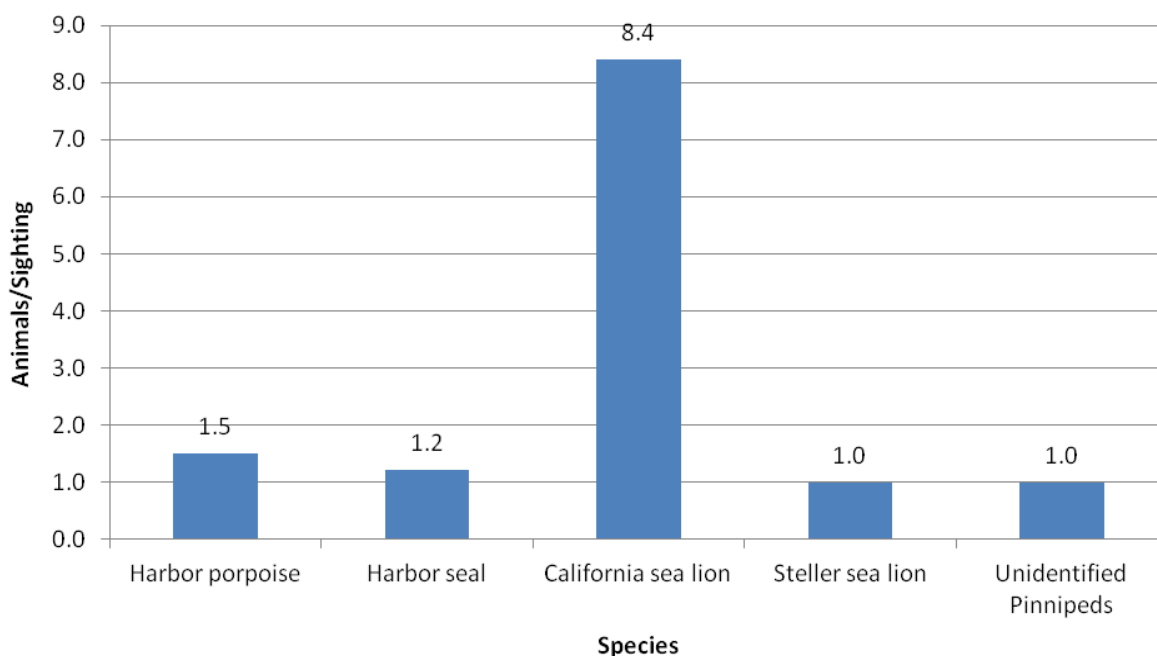
**Figure 10. Mean Number of Animals per Sighting (Phase 1)**



During Phase 2, a total of 159 sightings of 458 individual marine mammals were observed (**Table 15**) during marine mammal surveys on construction days. Observations include those made during pile driving activities, and those made during non-construction periods. The total number of survey hours in TPP Phase 2 was 130.34 with an average of 5.8 observers participating in surveys during this time frame (5 October 2011 through 20 October 2011). Four marine mammal species were identified during Phase 2: the harbor porpoise, harbor seal, California sea lion and Steller sea lion. Unidentified pinnipeds were not reliably identified to species and, as such, were grouped separately in the data. The harbor seal was again the most abundant species observed during Phase 2, and were sighted most often (0.15 sightings per hour). California sea lions had the highest number of animals per sighting (8.4 animals per sighting, **Figure 11**). The mean number of California sea lions per sighting was higher in Phase 2 (8.4) than in Phase 1 (6.2). This change could be due to the northward seasonal migration of this species in fall and winter (NMFS 1997).

**Table 15. Total Number of Animals and Sightings by Species (Phase 2)**

Species	Total # Animals	Total # Sightings	Sightings Per Obs Hr	Mean Group Size	Modal Group Size	Max Group Size	Min Group Size
Harbor porpoise	3	2	<0.01	1.5	N/A	2	1
Harbor seal	135	111	0.15	1.2	1	13	1
California sea lion	311	37	0.05	8.4	1	31	1
Steller sea lion	6	6	0.01	1.0	1	1	1
Unidentified Pinnipeds*	3	3	<0.01	1.0	1	1	1
<b>TOTAL</b>	<b>458</b>	<b>159</b>	<b>0.22</b>	<b>-</b>	<b>-</b>	<b>-</b>	<b>-</b>

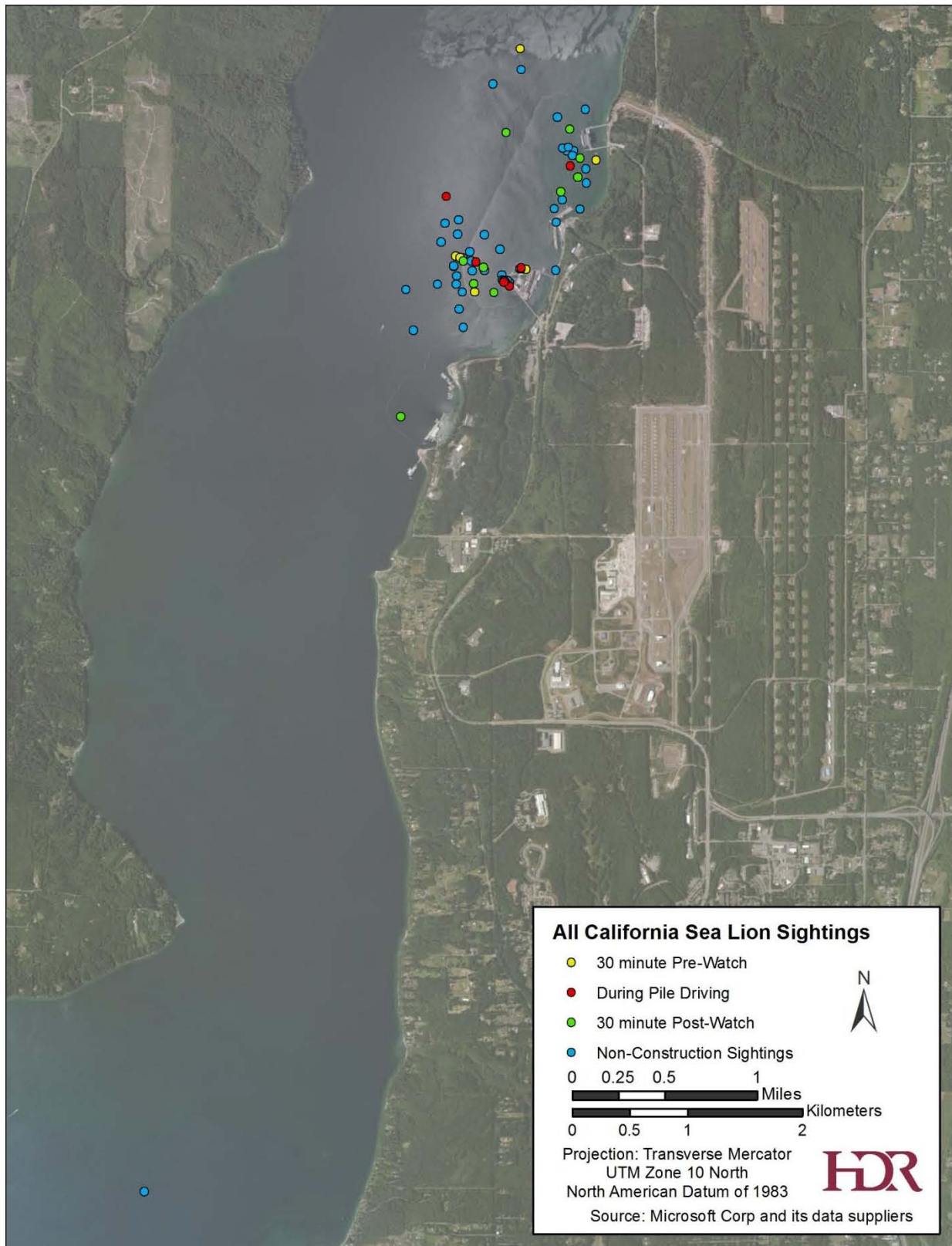


**Figure 11. Mean Number of Animals per Sighting (Phase 2)**

Observers typically surveyed for marine mammals during the entire construction day (8-10 hours). However, to more accurately depict marine mammal occurrence relative to the required monitoring period for pile driving activities (30 minute pre-survey, during pile installation/removal, and 30-minute post survey), the remainder of this section focuses on before/during/after construction time periods only. Harbor porpoise and Steller sea lion sightings are addressed separately in more detail due to concerns relative to take limits defined in the initial IHA issued for the TPP in June 2011 (NMFS, 2011). The two species most often sighted throughout the TPP, the harbor seal and California sea lion, did not demonstrate clear avoidance of the TPP work area during construction or immediately after construction (**Figures 12 and 13**). **Figure 13** in particular demonstrates the roughly even distribution of harbor seals before, during and after vibratory pile driving. Sixteen harbor seals were observed during impact driving, 15 of these during impact driving soft start procedures (**Figure 14**). Of these, 8 animals fell within the 160 dB harassment zone (for the particular piles associated with those sightings) and were considered takes. Only one California sea lion was observed during impact driving (**Figure 15**), but this animal was outside the measured 160 dB harassment zone, and therefore did not represent a Level B take.

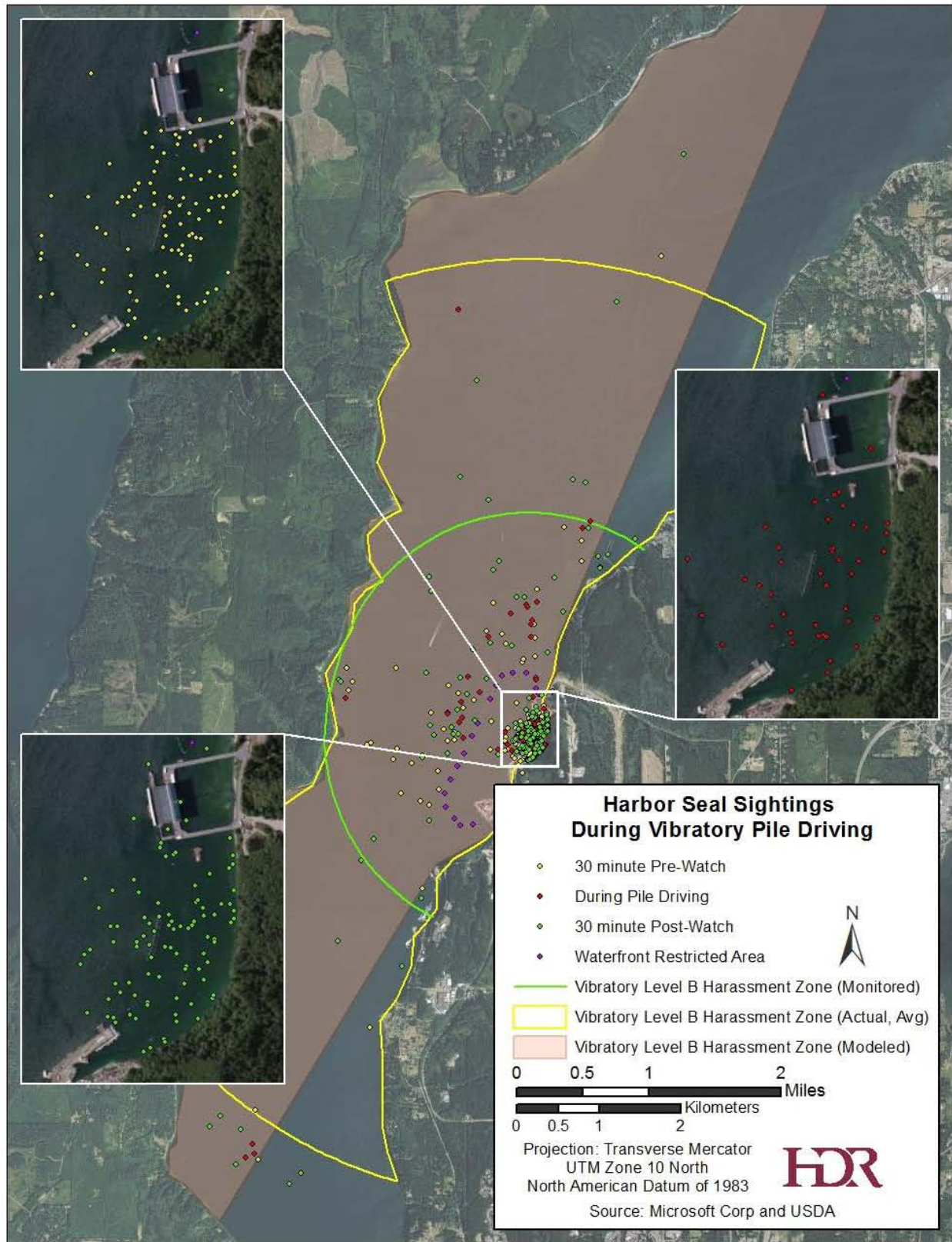
***Sightings During Pile Installation/Removal Activities.*** A total of 90 sightings of 162 individual marine mammals were observed during pile installation and removal activities in Phases 1 and 2 of the TPP (**Table 16**). Pile installation and removal activities included soft start procedures for either hammer type, and the actual installation or removal of the pile with an impact or vibratory hammer. Therefore, there were four types of construction: vibratory pile driving (V), vibratory soft start (SSV), impact pile driving (I), and impact soft start (SSI). Soft starts of both types involved several preliminary hammer strikes, performed at reduced force, to the pile about to be driven. Soft starts were intended to provide an opportunity for nearby marine animals to voluntarily leave the area, and thus avoid potential harassment or injury. More harbor seals (n=15) and harbor porpoise (n=4) were seen during impact soft starts than during impact pile driving itself (n=1 for both species). This may be an indication that animals did indeed leave the area after the soft start “warning”. Typically, more animals were observed during vibratory driving than during impact driving and soft starts. This is because vibratory drives lasted between 4 and 26 minutes, and all impact drives lasted less than two minutes. Three marine mammal species were observed while TPP construction was ongoing: the harbor porpoise, harbor seal, and California sea lion. Although Steller sea lions were observed during Phase 2 of TPP, none were observed during actual pile driving or removal events.

A total of 69 sightings of 96 individual marine mammals were observed during Phase 1 of pile installation and removal activities (**Table 17**). Three marine mammal species were identified: the harbor porpoise, harbor seal, and California sea lion. Overall, 17 harbor porpoise, 67 harbor seals, and 12 California sea lions were observed when pile driving was ongoing. Only a subset of these animals were considered “takes”, based on sighting position and estimated distance to the vibratory and impact injury and harassment thresholds (**Appendix G**). To account for varying levels of survey effort, sighting rates are presented as the number of sightings per observer hour, during construction periods only, for each species. There was a total of 11.25 hours of survey time *during construction activities* for TPP Phase 1, with an average of 6.21 observers participating in surveys over this time period. The total number of observer hours during construction activities for Phase 1 of TPP was 69.86. Sighting rates were highest for harbor seals (0.79 sightings per observer hour), and nearly 1 sighting per hour was recorded for all species during Phase 2 of the TPP.



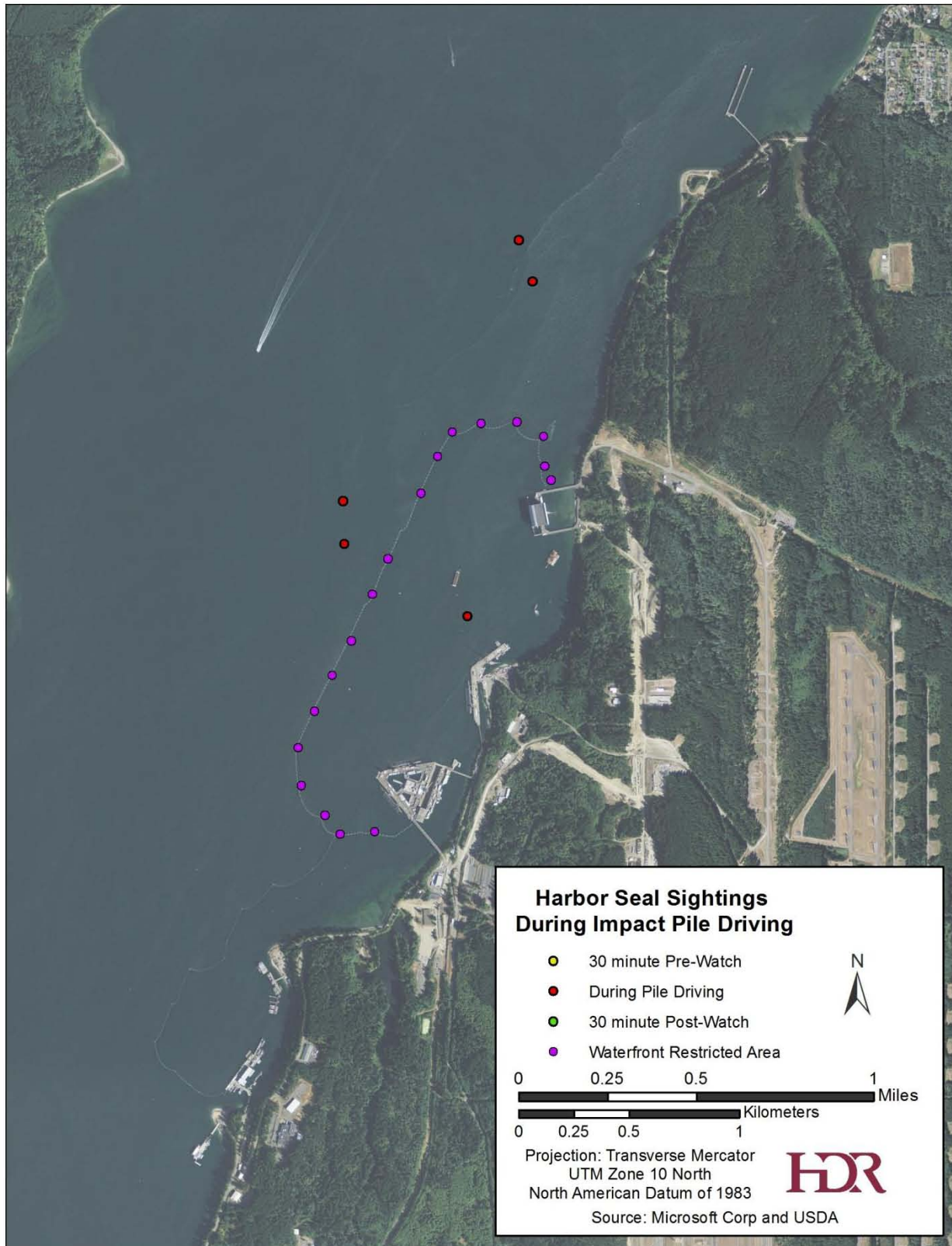
**Figure 12. All California sea lion sightings. Points may represent more than one individual.**



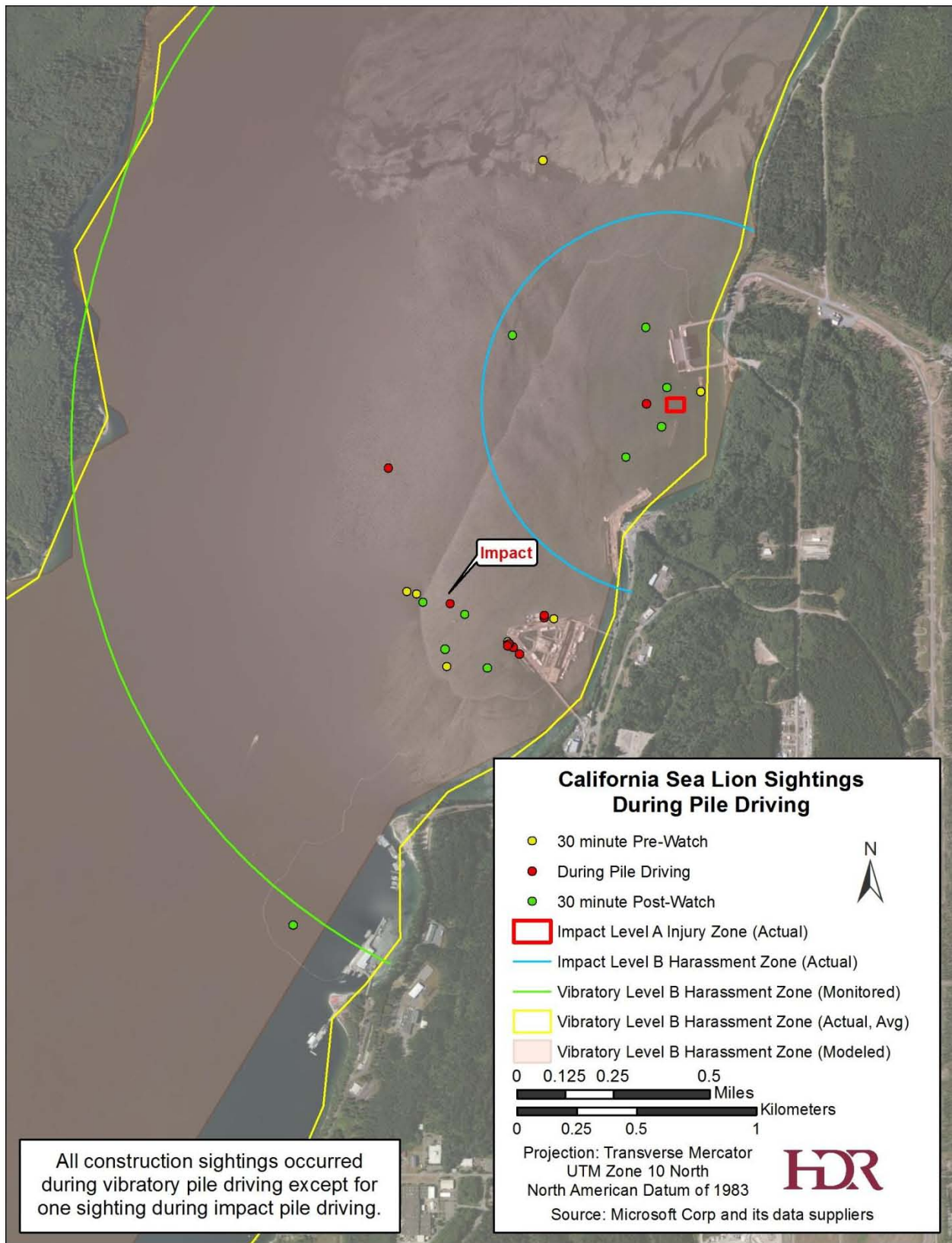


**Figure 13. Harbor seal sightings during vibratory pile driving. Points may represent more than one individual.**





**Figure 14. All harbor seal sightings during impact pile driving. Points may represent more than one individual.**



**Figure 15. California sea lion sightings during vibratory and impact pile driving. Points may represent more than one individual.**

**Table 16. Number of Animals and Sightings by Species During Pile Installation/Removal Activities (Phases 1 and 2)**

Species	Total # of Animals	Total # of Sightings	Construction Type			
			SSV*	V	SSI†	I
Harbor porpoise	18	10	1	12	4	1
Harbor seal	92	68	25	51	15	1
California sea lion	52	12	41	10	0	1
<b>TOTAL</b>	<b>162</b>	<b>90</b>	<b>67</b>	<b>73</b>	<b>19</b>	<b>3</b>

\*SSV = Vibratory Soft Start

†SSI = Impact Soft Start

**Table 17. Number of Animals and Sightings by Species During Pile Installation/Removal Activities (Phase 1)**

Species	Total # of Animals	Total # of Sightings	Sightings per Obs Hr	Construction Type			
				SSV*	V	SSI†	I
Harbor Porpoise	17	9	0.13	1	11	4	1
Harbor Seal	67	55	0.79	17	34	15	1
California Sea Lion	12	5	0.07	1	10	0	1
<b>TOTAL</b>	<b>96</b>	<b>69</b>	<b>0.99</b>	<b>19</b>	<b>55</b>	<b>19</b>	<b>3</b>

\*SSV = Vibratory Soft Start

†SSI = Impact Soft Start

A total of 21 sightings of 66 individual marine mammals were observed during Phase 2 of pile installation and removal activities (**Table 18**). Three marine mammal species were identified: the harbor porpoise, harbor seal, and California sea lion. Overall, 1 harbor porpoise, 25 harbor seals, and 40 California sea lions were observed when pile driving was ongoing. Only a subset of these animals were considered “takes”, based on sighting position and estimated distance to the vibratory and impact injury and harassment thresholds (**Table 19**). To account for varying levels of survey effort, sighting rates are presented as the number of sightings per observer hour, during construction periods only, for each species. There was a total of 6.15 hours of survey time *during construction* for TPP Phase 2, with an average of 5.86 observers participating in surveys over this time period. The total number of observer hours *during construction* for Phase 1 of TPP was 36.04. Sighting rates were highest for harbor seals (0.36 sightings per observer hour) and a total of 0.58 sightings per hour were recorded for all species combined. Sighting rates were higher in Phase 1 of the TPP than in Phase 2. This is likely due to the fact that for part of Phase 2, two marine mammal observers were dedicated to Delta Pier to observe Steller sea lion behavior, and were not available to record sightings in other areas of the WRA and Hood Canal.

**Table 18. Number of Animals and Sightings by Species During Pile Installation/Removal Activities (Phase 2)**

Species	Total # of Animals	Total # of Sightings	Sightings per Obs Hr	Construction Type			
				SSV*	V	SSI†	I
Harbor Porpoise	1	1	0.03	0	1	0	0
Harbor Seal	25	13	0.36	8	17	0	0
California Sea Lion	40	7	0.19	40	0	0	0
<b>TOTAL</b>	<b>66</b>	<b>21</b>	<b>0.58</b>	<b>48</b>	<b>18</b>	<b>0</b>	<b>0</b>

\*SSV = Vibratory Soft Start

†SSI = Impact Soft Start

**Table 19. Summary of Underwater and Airborne Marine Mammal Takes During the TPP**

Species	Authorized Take Numbers	Total Number of Takes*	Underwater Injury Zones (No. of Animals)		Underwater Harassment Zones (No. of Animals)			Airborne Harassment Zones (No. of Animals)	
			190 dB RMS	180 dB RMS	160 dB RMS	120 dB RMS (Actual)	120 dB RMS (Extrapolated)	100 dB RMS	90 dB RMS
Harbor seal	832	120	0	0	12	71	37	0	0
California sea lion	270	257	0	0	0	218	39	0	0
Killer whale	39	0	0	0	0	0	0	0	0
Dall's porpoise	31	0	0	0	0	0	0	0	0
Harbor porpoise	49†	23	0	0	0	3	20	0	0
Steller sea lion	0	1	0	0	0	0	1	0	0
<b>TOTAL</b>	<b>1221</b>	<b>401</b>	<b>0</b>	<b>0</b>	<b>12</b>	<b>292</b>	<b>97</b>	<b>0</b>	<b>0</b>

\*Includes Extrapolated takes for the 120 dB Behavioral Harassment Zone

†Permitted harbor porpoise takes were increased from 15 to 49 in a revised IHA for the TPP, issued October 2011

## Observed "Takes"

Injury and behavioral harassment takes were calculated for marine mammals sighted during TPP construction, including vibratory and impact driving, as well as soft start events for each type of construction. Takes were calculated by: (1) measuring sighting distance to pile for all animals observed during construction activities, and (2) comparing this distance to underwater and airborne injury and behavioral harassment thresholds on a *per-species* and *per-pile* basis (**Appendix G**). Sighting distance to pile was calculated by plotting animal locations based on distance and direction from the vessel (as recorded by observers on field data sheets) and relating these locations to pile location in a Geographical Information System (ESRI, Arc GIS v.10). If two distances to a sound threshold were measured for a single pile, (one from the North vessel in Hood Canal and one from the South vessel, for example) an average of these two distances was used to estimate the threshold distance and thus estimate takes for that pile driving event. Whenever possible, observers noted if an animal was likely a resighting (**Appendix H**) and



communicated with nearby observers in the field to “hand off” sightings of the same animal(s). This information was taken into account when calculating takes to avoid double-counting exposed animals. Takes are reported as the number of individuals (not sightings) observed within a given zone. The total number of marine mammal takes for the TPP is summarized in **Table 19**.

The number of observed takes never exceeded those permitted in the revised IHA (NMFS, 2011). In order to qualify as an airborne take, pinnipeds had to 1) be hauled out within the airborne harassment ZOI, or 2) have their head above the water for the duration of the pile driving event (or sighting) (NMFS pers. comm. with Navy, 2012). Of the 7 animals (all harbor seals) that were seen within the airborne ZOI (see **Appendix G**), all were recorded as sinking or diving during pile driving (see **Appendix H**), and therefore did not qualify as airborne takes. All 7 animals were, however, Level B underwater takes (**Table 19**). The airborne harassment threshold for sea lions and Steller sea lions (100 dB) reached a maximum of 39 m during the TPP, and no animals of either species were seen within this radius during any construction event. California sea lions typically hauled out along the port security barrier (approximately 500 m to 700 m from the construction area) and at Delta Pier (approximately 1,160 m -1,500 m from the construction area, **Figure 12**). No Dall’s porpoise or killer whales were observed during construction (or at any other time) during the TPP.

No injury takes of cetaceans or pinnipeds occurred during the TPP. For impact driving, the distance to the maximum RMS level of 180 dB, the injury zone for cetaceans, averaged approximately 60 meters but did extend out to 100 m during a few instances when the air bubble curtain system was operating. There were four piles where maximum levels exceeded 180 dB RMS at 100 m (**Table 7**). In one case, the maximum 180-dB RMS level extended out to an estimated 200 m. However, the 180-dB level did not extend beyond 20 m for 9 of the drives (**Table 7**). When the air bubble curtain was off, the maximum 180-dB RMS level extended out to 150 to 300 m. While these distances are larger than those predicted in the Navy’s environmental compliance documents by the practical spreading loss model, the enlarged injury zones did not result in any unauthorized cetacean takes. No cetacean species were sighted within the water restricted area (WRA) at NBK at Bangor, including during all marine mammal monitoring associated with the TPP. The WRA fence is located 500 to 700 m from the shoreline, well beyond the farthest distance to the 180 dB threshold when the air bubble curtain was off.

Maximum levels of 190 dB RMS for impact driving typically did not extend beyond 10 to 20 m from the pile when the air bubble curtain system was operating (**Table 7**). When the air bubble curtain was off, maximum 190-dB RMS levels extended from 10 to 60 m out from the pile (**Table 7**). While these distances are slightly larger than those predicted in the Navy’s environmental compliance documents by the practical spreading loss model, the enlarged injury zones did not result in unauthorized takes of any pinnipeds. In fact, sound pressure levels were within the monitored shutdown zone during both attenuated and unattenuated impact pile driving at all times, with the exception of one unattenuated testing event of a 36-inch pile on September 10, 2011 which lasted less than one minute in duration. During the bubble curtain test on September 10, 2011, which occurred at 14:56-14:57, no marine mammals were observed within over an hour of the testing event (the last marine mammal sighting on that day occurred at 13:28).

For vibratory pile driving, dB levels never reached as high as 190 dB at 10 m, and in only one case reached 180 dB at 10 m (TP#3 on August 30, 2011, **Table 9**). There were no marine mammals within 10 m of the pile for that drive (**Appendix G**). In fact, the closest sighting to pile driving throughout the TPP, a harbor seal, was located 30 m from the pile (**Appendix G**).

There was a total of 292 observed behavioral (Level B) harassment takes during the TPP: 12 harbor seals during impact driving (160 dB behavioral threshold) and 71 harbor seals, 218 California sea lions, and 3 harbor porpoise fell within the harassment zone during vibratory pile driving. The closest sighting to pile driving activities occurred on 21 September at 10:10. A harbor seal was located 50 m from the pile during an impact soft start (**Appendix G**). At the time of sighting, the observer estimated the animal distance to pile at 75 m, and therefore the sighting did not trigger a construction shutdown. The sighting was calculated as a Level B take, since all takes were based on actual (corrected) animal-to-pile distances. Corrected distances were calculated based on distance and direction from observer as recorded in sighting data sheets.

**Calculation of Average Sound Thresholds.** Measured sound threshold distances varied considerably with pile size, substrate type, environmental conditions and background noise levels. Therefore, average distances to the behavioral harassment thresholds were calculated for the purposes of 1) visualizing the relative distances to the actual, modeled, and monitored Level B harassment zones (**Figure 5**) and 2) extrapolating the number of possible Level B takes in the unmonitored ensonified area from known animal density and sighting rates. The average distance to 120 dB threshold for vibratory pile driving was calculated by taking the weighted average of distances to the 120 dB threshold for each pile size and hydrophone depth. There were 2 24-inch, 48 36-inch and 15 48-inch vibratory pile driving events during the TPP. The average threshold distance for 24-inch piles was **2,635 m**, for 36-inch piles was **6,082 m**, and for 48-inch piles was **5,046 m** (see **Table 20**).

**Table 20. Distances to 120 dB RMS Sound Level Threshold from Vibratory Pile Driving**

Activity	Distances (m)*		
	Deep	Mid Depth	Avg.
24" Pile	3,147	2,122	2,635
36" Pile	7,499	4,664	6,082
48" Pile	6,587	3,505	5,046

\* Distances to thresholds are based on average maximum RMS levels measured for the project

The weighted average was calculated as follows:

$$(2*2,635) + (48*6,082) + (15*5,046) / 65 \text{ (total number of vibratory events)}$$

Therefore, the average distance to the 120 dB threshold is **5,737 m**. The predicted (modeled) area for the 120 dB threshold at the start of the project was approximately 13,600 meters to the north and 6,800 meters to the south,. The area within the average measured 120 dB threshold was 32,640 square meters versus the predicted 41,500 sq. meters.

The average distance to 160 dB threshold for impact pile driving varied with air bubble curtain use. The average threshold distance for 24-inch piles was 108 m with the curtain (1 event) and 282 m without (1 event), for 36-inch piles the average threshold distance was 398 m with the curtain (17 events) and 970 m without (5 events), and for 48-inch piles the average threshold was 1,180 m with the curtain (4 events) and 3,710 m without (2 events). The weighted average was calculated as follows:

With bubble curtain:

$$\frac{(1*108) + (17*398) + (4*1,180)}{22} \text{ (total number of impact drives with curtain)}$$

Without bubble curtain:

$$\frac{(1*282) + (5*970) + (2*3,710)}{8} \text{ (total number of impact drives without curtain)}$$

Therefore, the average distance to the 160 dB threshold was **505** m when the bubble curtain was in use, and **1,569** m when the bubble curtain was not in use. The area that fell within this radius was 4.10 km<sup>2</sup>. A 2.4 km radius (10.32 km<sup>2</sup> area) was monitored throughout the TPP, so it can be concluded that the unattenuated impact driving harassment zone did receive adequate observer coverage during the TPP project.

### **Extrapolated Level B Takes for the Unmonitored Zone**

The measured behavioral harassment zone during vibratory pile driving, defined as the area within the average distance to the 120 dB isopleth during the TPP (calculated as a 5,737 m radius from the construction location), covered 32.64 km<sup>2</sup>. Only a subset of this area was monitored (2.4 km radius from the pile, or 10.32 km<sup>2</sup>) because of logistical constraints. It is therefore appropriate to estimate the number of potential Level B marine mammal takes that may have occurred in the unmonitored, but unmonitored, zone. To extrapolate missed takes, species density in Hood Canal (individuals observed during TPP per km<sup>2</sup> per hr) was multiplied by the unmonitored area that fell within the measured harassment zone. The product of these two numbers represents the estimated density (individuals/km<sup>2</sup>/hr) in the unmonitored zone. Species density in the unmonitored zone was then multiplied by the total number of construction hours during the TPP to arrive at an estimate of the numbers of takes missed in the unmonitored, unmonitored zone (**Table 21**). Only sighting rates from outside the WRA were considered in the analysis, since these were likely more representative of animal densities in the unmonitored zone, because habitat use by these species was markedly different between within and outside of the WRA. It should be noted that the density estimates were not collected using standard line-transect methodology, since at the time of writing these data were not available for Hood Canal for all species in question. Using the methods outlined above, it is estimated that approximately 20 harbor porpoise, 37 harbor seals, 39 California sea lions and <1 Steller sea lions were “taken” in the unmonitored section of the behavioral harassment zone for marine mammals. While 0.35 potential Steller sea lions were extrapolated for the unmonitored area, based on the Navy’s take calculation methodology used in the TPP environmental compliance documents, this would not be considered a take since this value fell below 0.5. Additionally, these values are likely conservative because during Phase 1 more observers were present at the project site and the area monitored exceeded the minimum 2.4 km radius. However, because these additional vessels were often far apart assisting with acoustic recordings to determine the distance to the 120 dB RMS it was difficult to assess what additional area of coverage they

provided. As a result, all calculations were conducted assuming the minimum monitored area mandated in the IHA permit, a circle with a 2.4 km radius from the pile.

**Table 21. Missed Takes in the Unmonitored Area of the Behavioral Harassment Zone**

Species	Density Estimate	Measured Level B Harassment Zone (Area, km <sup>2</sup> )	Monitored Area (km <sup>2</sup> )	Unmonitored Harassment Zone (Area, km <sup>2</sup> )	Estimated Density in Unmonitored Area	Total Construction Hours During TPP (Both Phases)	Missed Takes (Estimated)
Harbor porpoise	0.052	32.64	10.32	22.32	1.16	17.4	20.18
Harbor seal	0.095				2.12		36.89
California sea lion	0.101				2.25		39.15
Steller sea lion	0.001				0.02		0.35

### Marine Mammal Mitigation Procedures and Shutdowns

When a marine mammal was observed in or approaching the 50-m shutdown zone, ongoing construction was shut down, and imminent construction was delayed. During the TPP there were

five construction shutdowns and five construction delays due to: (1) marine mammals (in all cases harbor seals) present in the 50-m shutdown zone prior to, or during, pile driving activities; or (2) harbor porpoise observed approaching the WRA, which automatically triggered a construction shutdown to avoid unauthorized harbor porpoise takes (**Table 22**). The latter condition was invoked prior to October 18, 2011, before the IHA for the TPP was revised to include 34 additional harbor porpoise takes. Since there were no Steller sea lion takes permitted the initial or revised IHA, protocol required a complete construction shutdown if a Steller sea lion that was hauled out made a move to enter the water. Dedicated Steller sea lion observers were positioned to track their movements, and two construction shutdowns (one on October 19 and another on October 20) were triggered by a hauled-out Steller sea lion moving towards the water (**Table 22**). In both cases, unauthorized Level B takes were avoided by the shutdown protocol. On September 17, there was a 1 hour and 10 minute delay of impact pile driving due to a Beaufort sea state above 3, which triggered a protocol shutdown because it was not possible to effectively monitor for marbled murrelets (Hart Crowser 2012).

**Table 22. Marine Mammal Mitigation Events During the TPP**

Date	Pile No.	Drive Type	Length of Shutdown/Delay (hr:mn)	Species	Number of Animals
9/15/2011	TP#3-R#3	Impact	:20	HPOR^	-
9/24/2011	TP#9-R#3	Vibratory	:15	HSEA^	1
9/29/2011	TP#12	Impact	:22	HSEA^	1
9/29/2011	TP#11	Impact	:12	HSEA^	1
10/1/2011	TP#9-R#3	Impact	:07	HSEA^	1

10/3/2011	TP#4	Vibratory (out)	:15	HSEA*	1
10/5/2011	TP#1	Vibratory	1:07	HSEA*	1
10/8/2012	TP#1	Impact	:11	HSEA*	1
10/19/2011	TP#9-M3	Vibratory (out)	1:42	STSL*	1
10/20/2011	TTP-4	Vibratory (out)	:23	STSL*	1

^ Construction delay

\* Construction shutdown

**Harbor Porpoise Sightings.** All harbor porpoises observed during the TPP were outside the port security barrier (WRA fence). There were 68 sightings of 125 harbor porpoises during marine mammal surveys on construction days during the course of the TPP, and this species had a mean group size of 1.8 (**Table 13, Figure 16**). Of these, 33 sightings occurred during the required marine mammal monitoring period for pile installation/removal activities (i.e. the 30 minute pre-construction survey, during pile installation/removal, and the 30 minute post-construction survey) (**Table 23, Figure 17**). Sighting rates of harbor porpoise dropped from 0.13 sightings per observer hour (Phase 1) to 0.03 sightings per observer hour (Phase 2) over the course of the TPP (**Tables 13 and 14**), possibly indicating a seasonal change in the occurrence of this species in Hood Canal. Ten harbor porpoise sightings of 18 individuals occurred during the actual installation or removal of piles (including soft start procedures, **Table 23**). Of these, two sightings (3 individuals) occurred within the measured 120 dB behavioral harassment zone for vibratory driving, and were considered Level B takes: two animals on 30 August and one animal on 8 September (**Table 19, Appendix G**). No harbor porpoise were observed within the 180 dB injury zone for cetaceans during any type of pile driving. The initial IHA for TPP issued in June 2011 allowed for only 15 harbor porpoise “takes”. More up-to-date distribution and density data for this species was collected during baseline surveys concurrent with the TPP, and these improved estimates were used to inform a revised version of the TPP IHA, issued by NMFS in October 2011. After the IHA revision 49 Level B takes for this species were permitted. Three observed takes and 20 extrapolated takes occurred during the TPP, for a total of 23 (**Table 19**).

**Steller Sea Lion Sightings.** As Steller sea lions typically do not arrive in the vicinity of NBK at Bangor until well into November (A. Balla-Holden, pers. comm.), their appearance during the TPP was unexpected, and no takes of any kind were permitted under the initial or revised IHA documents (NMFS 2011a,b). The first sighting of this species during the TPP occurred on 8 October 2011. The majority of sightings were made near Delta Pier, a berthing facility that accommodates multiple submarines. The submarines themselves were used as a haul-out site by both Steller and California sea lions (**Appendix I, Figure I-5**). It is speculated that the heat signature of these vessels provides an attractive haulout site for pinnipeds to rest and thermoregulate. All Steller sea lions appeared to be adult or subadult males, and often had mildly agonistic interactions with the California sea lions also hauled out on the submarines. Steller sea lions were most commonly observed resting, swimming, and vocalizing, usually during interactions with California sea lions. One Steller sea lion observed at Delta Pier was branded with a large “102 Y” along its left flank (**Appendix I, Figure I-4**). The National Marine Mammal Laboratory database indicates that this animal was therefore a male branded in July 2002 as a pup at St. George Reef, CA.

A total of six individual Steller sea lions (one per sighting) were observed on construction days during the TPP (**Table 24**), with a sighting rate of 0.01 per observer hour (**Table 14**) *although*



*none were observed during impact or vibratory pile driving activities.* Therefore, there were no observed unauthorized takes of Steller sea lions during the TPP. Note that a separate pile driving project at NBK at Bangor, EHW-1, was conducted concurrently with the TPP. Steller sea lions observations for that project also appear in **Table 24**, but are addressed in detail in a separate report. With the exception October 4, October 5, October 17 and October 19, when TPP and EHW-1 construction occurred on the same day, construction alternated days for each project. When construction for both projects did occur on the same day, activity for the respective projects was generally sufficiently separated in time and space to clearly assign marine mammal observations to one project or the other. On October 12 2011 (an EHW-1 day only) a monitoring vessel performed a post-construction sweep of the WRA, and when the vessel arrive at Delta Pier, a wet Steller sea lion was observed hauled out on a submarine. Although the animal was not seen in the water, it was assumed that it had been in the water recently and therefore may have been exposed to construction noise. **Figure 6** shows the approximate locations of the Steller sea lion sightings during Phase 2 of the TPP. No Steller sea lions were seen during Phase 1 of the TPP.

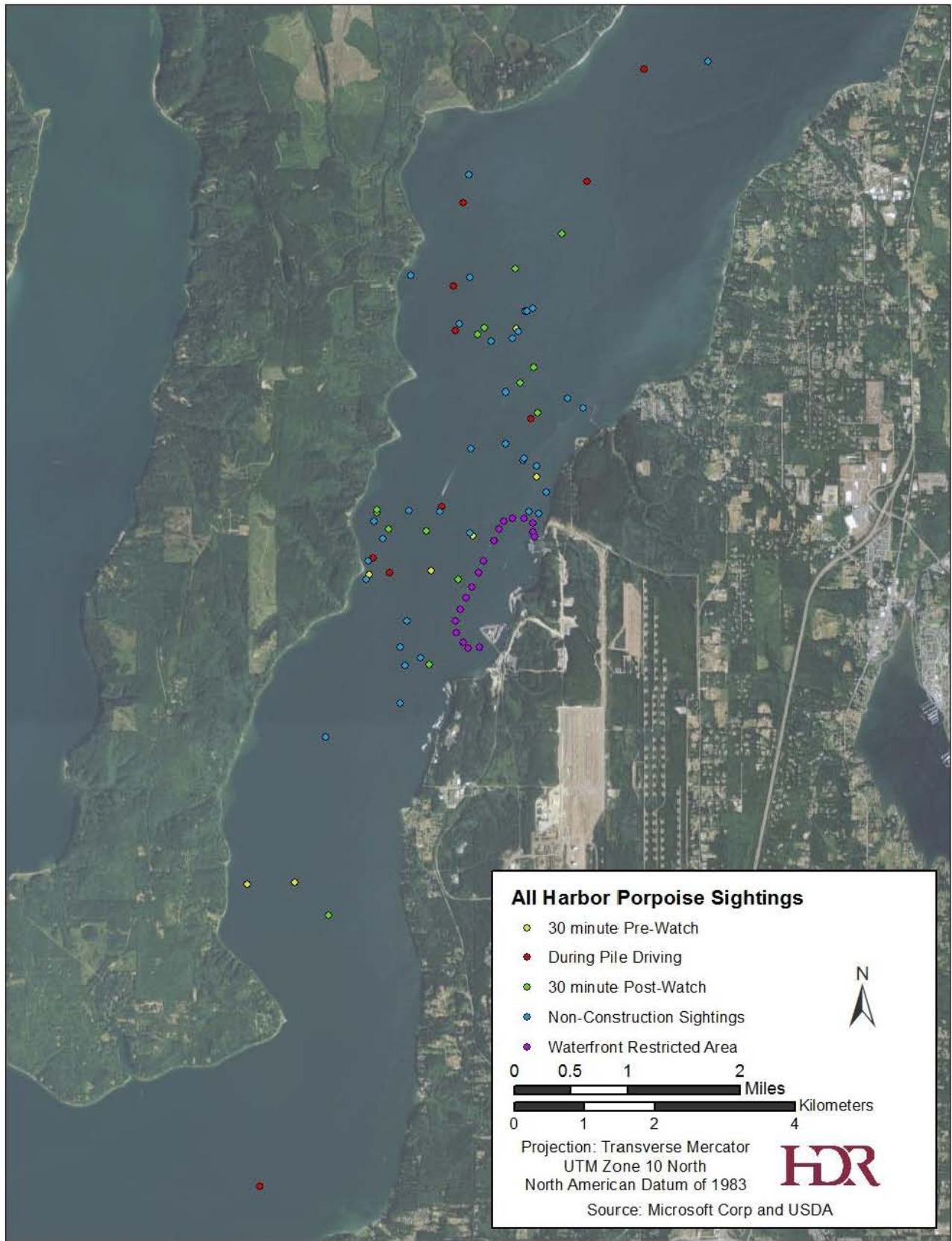
### Other Sightings

During marine mammal monitoring for the TPP, several non-marine mammal species were also observed in the waters in the vicinity of the pile driving site. During Phase 1 of the TPP, there was one sighting of six North American river otters (**Table 25**). This sighting occurred during a time period when there was no construction underway. The North American river otter (*Lontra canadensis*) is a mammal species that inhabits primarily freshwater rivers and terrestrial habitats. While it occasionally occurs in marine waters, this species is not regulated under the MMPA or listed under the ESA. The northern river otter falls under the jurisdiction of the USFWS.

**Table 25. Other Sightings of Marine Species, by Number of Animals and Sightings, Observed During Pile Driving (Phases 1 and 2)**

Species	Total Number of Animals	Total Number of Sightings
River otter	6	1
Pacific herring	1	1

Additionally, one fish was observed during the TPP that appeared to be in distress and behaving abnormally. A Pacific herring was observed at the surface of the water, intermittently swimming in slow circles and floating motionless at the surface. The sighting was made on 29 August 2011 at 12:20 PM, during vibratory driving of a 24inch pile, using an APE 400 vibratory hammer. The fish was located approximately 50 m from the pile (**Figure 18**), and was lifted from the water by monitoring staff for inspection, identification and measurement. No physical trauma or abnormalities were observed. The fish was released back in the water following the examination, which lasted several seconds. The fish remained motionless in the water and drifted from sight.



**Figure 16. All harbor porpoise sightings. Points may represent more than one individual.**

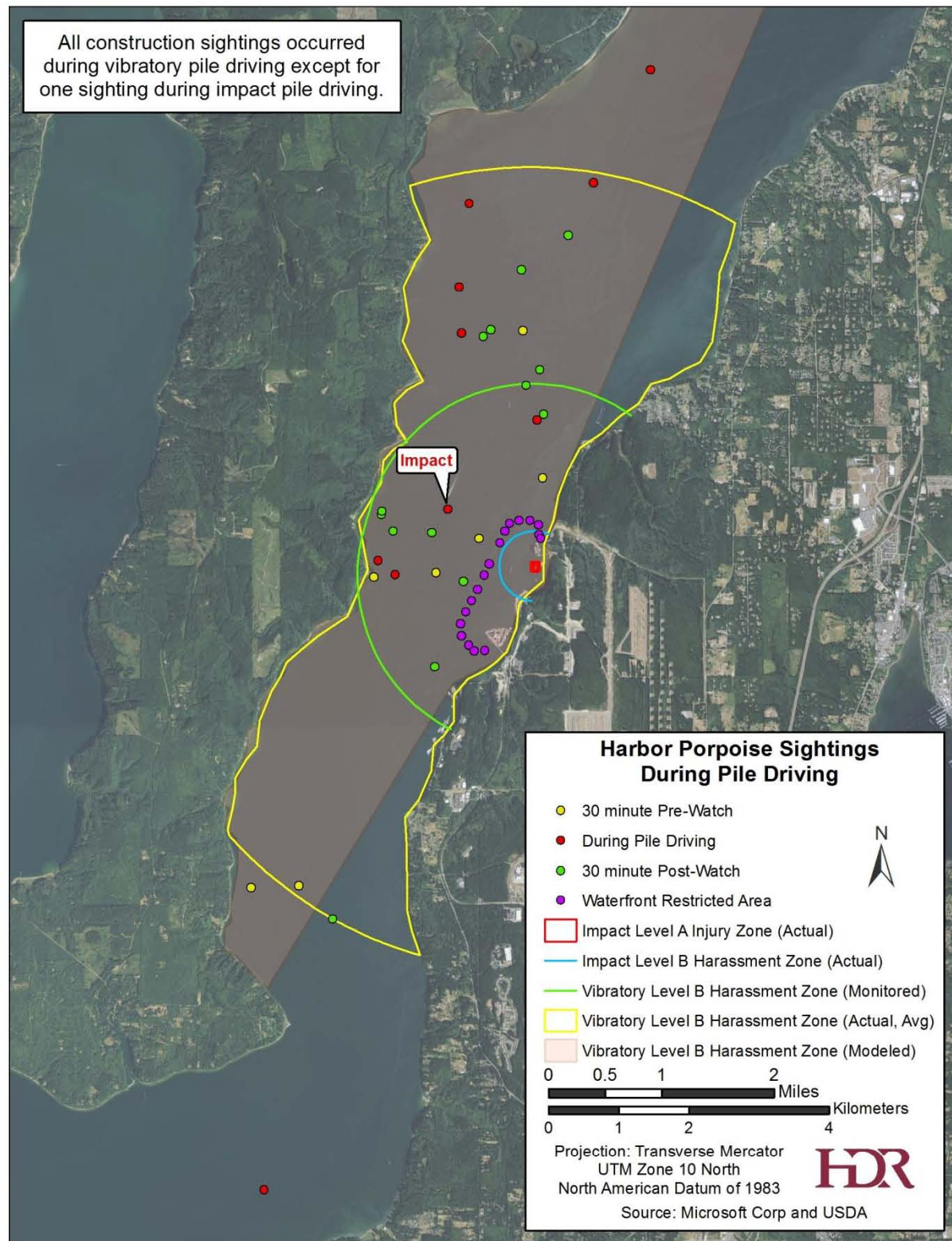
**Table 23. All Harbor Porpoise Sightings During 30 Minute Pre-Watch, Pile Driving Activity, and 30 Minute Post-Watch Time Periods**

	Sighting occurred during the TPP project when no construction was ongoing
	Sighting occurred during the TPP project, during vibratory or impact pile driving

Date	Sighting Time	# of Animals	Est. Distance to Pile (m)	Monitoring Activity Type
<b>Phase 1</b>				
29-Aug-11	15:47	2	>2000	30 minute post-watch (Vibratory)
<b>30-Aug-11</b>	<b>14:49</b>	<b>2</b>	<b>1000</b>	<b>Vibratory pile driving‡</b>
30-Aug-11	15:12	2	600	30 minute post-watch (Vibratory)
30-Aug-11	15:17	4	4000	30 minute post-watch (Vibratory)
31-Aug-11	09:13	1	2400	30 minute pre-watch (Vibratory)
31-Aug-11	10:16	1	4000	30 minute post-watch (Vibratory)
31-Aug-11	10:27	2	5000	30 minute post-watch (Vibratory)
31-Aug-11	12:38	2	5000	30 minute post-watch (Vibratory)
<b>8-Sep-11</b>	<b>14:41</b>	<b>2</b>	<b>3950</b>	<b>Vibratory pile driving</b>
<b>8-Sep-11</b>	<b>15:01</b>	<b>3</b>	<b>3950</b>	<b>Vibratory pile driving</b>
<b>8-Sep-11</b>	<b>16:17</b>	<b>1</b>	<b>4000</b>	<b>Soft Start prior to vibratory pile driving‡</b>
8-Sep-11	17:21	1	2320	30 minute post-watch (Vibratory)
10-Sep-11	12:39	1	5815	30 minute pre-watch (Vibratory)
<b>10-Sep-11</b>	<b>13:03</b>	<b>2</b>	<b>7300</b>	<b>Vibratory pile driving</b>
15-Sep-11	13:49	1	949	30 minute pre-watch (Impact)
15-Sep-11	13:50	3	1200	30 minute pre-watch (Impact)
<b>15-Sep-11</b>	<b>14:26</b>	<b>2</b>	<b>2200</b>	<b>Soft Start prior to impact pile driving</b>
<b>16-Sep-11</b>	<b>10:53</b>	<b>1</b>	<b>1126</b>	<b>Impact pile driving</b>
16-Sep-11	15:40	2	1600	30 minute post-watch (Impact)
16-Sep-11	15:42	2	1500	30 minute pre-watch (Impact)
16-Sep-11	16:04	2	1800	30 minute pre-watch (Impact)
<b>16-Sep-11</b>	<b>16:10</b>	<b>2</b>	<b>2000</b>	<b>Soft Start prior to impact pile driving (re-sighting of animals at 16:04)</b>
16-Sep-11	16:40	1	1040	30 minute post-watch (Impact)
21-Sep-11	14:20	1	4000	30 minute pre-watch (Vibratory)
<b>29-Sep-11</b>	<b>16:34</b>	<b>1</b>	<b>5900</b>	<b>Vibratory pile driving</b>
29-Sep-11	16:42	2	5800	30 minute post-watch (Vibratory)
30-Sep-11	11:46	5	6000	30 minute pre-watch (Vibratory)
1-Oct-11	16:26	2	1300	30 minute pre-watch (Impact)
1-Oct-11	16:53	4	2160	30 minute post-watch (Impact)
3-Oct-11	17:10	1	3000	30 minute post-watch (Impact)
3-Oct-11	18:05	2	2800	30 minute post-watch (Vibratory)
3-Oct-11	18:20	3	2310	30 minute post-watch (Vibratory)
<b>Phase 2</b>				
<b>5-Oct-11</b>	<b>16:32</b>	<b>1</b>	<b>10000</b>	<b>Vibratory pile driving</b>

‡Incident represents a Level B take





**Figure 17. Harbor porpoise sightings during vibratory and impact pile driving. Points may represent more than one individual.**

**Table 24. All Steller Sea Lion Sightings**

	Sighting occurred during the TPP project when no construction was ongoing
	Sighting occurred during the EHW-1 project when no construction was ongoing
	Sighting occurred during the EHW-1 project, during the time period of vibratory pile installation/removal

Date	Sighting Time (hh:mm)	Project Name	# of Animal(s)	Est. Distance to Pile (m)	Monitoring Activity Type	Notes
8-Oct-11	13:20	TPP	1	N/A	No construction	New Sighting
10-Oct-11	17:15	EHW-1	1	1,400	30 minute post-watch	New Sighting. MMO notes indicate that this individual was hauled out on a submarine.
11-Oct-11	18:04	EHW-1	1	1,080	30 minute post-watch	New Sighting. MMO notes indicate that this individual was hauled out on a submarine and was identifiable because it was "very blonde"
11-Oct-11	18:10	EHW-1	1	1,450	30 minute post-watch	New Sighting. MMO notes indicate that this individual was hauled out on a submarine and was identifiable because it was a "very large individual" that "had small wound or scar in left corner of mouth and noticeably protruding front teeth."
12-Oct-11 <sup>^</sup>	07:34	EHW-1	1	N/A	No construction	New Sighting
12-Oct-11	07:48	EHW-1	2	N/A	No construction	New Sighting
12-Oct-11	07:48	EHW-1	1	N/A	No construction	Resighting. Individual judged to be a resighting of the individual at 07:34 based on MMO notes, a continuation of the same sighting number, and timeframes associated with sightings.
12-Oct-11	09:10	EHW-1	1	N/A	No construction	Resighting. Individual judged to be a resighting of one of the individuals at 07:48 based on MMO notes, a continuation of the same sighting number, and timeframes associated with sightings.
12-Oct-11	09:20	EHW-1	1	N/A	No construction	Resighting. Individual judged to be a resighting of one of the individuals at 07:48 based on MMO notes, a continuation of the same sighting number, and timeframes associated with sightings.
12-Oct-11	18:28	EHW-1	1	1,500	30 minute post-watch	New Sighting. MMO notes indicate that this individual was hauled out on a submarine and was identifiable because it was a "large Steller."



Date	Sighting Time (hh:mm)	Project Name	# of Animal(s)	Est. Distance to Pile (m)	Monitoring Activity Type	Notes
13-Oct-11	14:40	EHW-1	1	1,300	30 minute post-watch	New Sighting. MMO notes indicate that this individual was hauled out on a submarine and was identifiable because of a brand showing "102Y."
14-Oct-11*	11:03	EHW-1	1	N/A	No construction	New Sighting
14-Oct-11	11:23	EHW-1	1	N/A	No construction	Resighting. This individual was sighted by a different MMO than the sighting at 11:03. However, based on the MMO notes, focal follow data, and proximity of the MMO to the MMO who made the sighting at 11:03, this sighting is considered as a resighting of the same individual seen at 11:03.
14-Oct-11	16:40	EHW-1	1	2,000	30 minute pre-watch	New Sighting
15-Oct-11	07:47	EHW-1	1	N/A	No construction	New Sighting. Sighted Prior to beginning Monitoring effort. Therefore, not counted as sighting in summary tables. Last seen at 08:20 leaving area to south.
15-Oct-11	08:18	EHW-1	2	N/A	No construction	New Sighting
15-Oct-11	09:14	EHW-1	1	N/A	No construction	Resighting. MMO notes indicate that the individual swam from the north submarine to the south submarine. Considered a re-sighting of one of the two individuals seen at 08:18
15-Oct-11	09:53	EHW-1	1	N/A	No construction	New Sighting
15-Oct-11	12:29	EHW-1	1	2,000	30 minute pre-watch	Resighting. One of two individuals noted at 08:18. Identified by brand 102Y.
17-Oct-11	08:15	TPP	1	N/A	No construction	New Sighting
17-Oct-11	08:51	TPP	1	N/A	No construction	New Sighting
17-Oct-11	09:22	TPP	1	N/A	No construction	Resighting. MMO notes indicate that the same individual was seen swimming back and forth from one sub to the other throughout the day. Considered as a re-sighting of the same individual seen at 08:15.
17-Oct-11	10:11	TPP	1	N/A	No construction	Resighting. MMO notes indicate that the same individual was seen swimming back and forth from one sub to the other throughout the day. Considered as a re-sighting of the same individual seen at 08:15.

Date	Sighting Time (hh:mm)	Project Name	# of Animal(s)	Est. Distance to Pile (m)	Monitoring Activity Type	Notes
17-Oct-11	11:22	TPP	1	N/A	No construction	Resighting. MMO notes indicate that the same individual was seen swimming back and forth from one sub to the other throughout the day. Considered as a re-sighting of the same individual seen at 08:15.
17-Oct-11	11:27	TPP	1	N/A	No construction	Resighting. MMO notes indicate that the same individual was seen swimming back and forth from one sub to the other throughout the day. Considered as a re-sighting of the same individual seen at 08:15.
17-Oct-11	11:45	TPP	1	N/A	No construction	Resighting. MMO notes indicate that the same individual was seen swimming back and forth from one sub to the other throughout the day. Considered as a re-sighting of the same individual seen at 08:15.
17-Oct-11	12:07	TPP	1	N/A	No construction	Resighting. MMO notes indicate that the same individual was seen swimming back and forth from one sub to the other throughout the day. Considered as a re-sighting of the same individual seen at 08:15.
17-Oct-11	12:44	TPP	1	2,000	30 minute pre-watch	Resighting. MMO notes indicate that the same individual was seen swimming back and forth from one sub to the other throughout the day. Considered as a re-sighting of the same individual seen at 08:15.
17-Oct-11	12:48	TPP	1	2,000	30 minute pre-watch	Resighting. MMO notes indicate that the same individual was seen swimming back and forth from one sub to the other throughout the day. Considered as a re-sighting of the same individual seen at 08:15.
17-Oct-11	14:17	TPP	1	N/A	No construction	Resighting. MMO notes indicate that the same individual was seen swimming back and forth from one sub to the other throughout the day. Considered as a re-sighting of the same individual seen at 08:15.
18-Oct-11	08:15	TPP	1	N/A	No construction	New Sighting
19-Oct-11	07:50	TPP	1	N/A	No construction	New Sighting

Date	Sighting Time (hh:mm)	Project Name	# of Animal(s)	Est. Distance to Pile (m)	Monitoring Activity Type	Notes
19-Oct-11	09:48	TPP	1	910	30 minute pre-watch	Resighting. MMO notes indicate that the individual was resting until it entered the water and surfaced outside of the WRA at 09:48. Considered as a re-sighting of the same individual seen at 07:50. It left the area, and did not come back.
20-Oct-11	14:49	TPP	1	N/A	No construction	New Sighting
21-Oct-11	15:39	EHW-1	1	1330	Vibratory pile driving†	<b>New sighting. MMO notes indicate that this was a “large Steller” that hauled out onto a submarine during vibratory driving. Construction shut-down.</b>
21-Oct-11	15:40	EHW-1	1	1,360	Between two hammer run times	New Sighting. MMO notes indicate that this was a “small Steller” that was hauled out on a submarine. Hammer was not on during sighting.
27-Oct-11	09:56-10:05	EHW-1	2	1,250	Vibratory pile driving	<b>New Sighting. MMO notes indicate that these individuals were hauled out on a submarine prior to and during pile driving activities.</b>
27-Oct-11	10:07-10:11	EHW-1	2	1,250	Vibratory pile driving	<b>Resighting. Considered as a resighting of the same individuals noted during the 09:56 to 10:05 timeframe because the MMO was watching the same location at all times, and MMO notes did not indicate that new individuals arrived on site. Animal was hauled out during pile driving activities.</b>
27-Oct-11	10:15-10:20	EHW-1	2	1,250	Vibratory pile driving	<b>Resighting. Considered as a resighting of the same individuals noted during the 09:56 to 10:05 timeframe because the MMO was watching the same location at all times, and MMO notes did not indicate that new individuals arrived on site. Animal was hauled out during pile driving activities.</b>
27-Oct-11	10:23-10:28	EHW-1	2	1,250	Vibratory pile driving	<b>Resighting. Considered as a resighting of the same individuals noted during the 09:56 to 10:05 timeframe because the MMO was watching the same location at all times, and MMO notes did not indicate that new individuals arrived on site. Animal was hauled out during pile driving activities.</b>

Date	Sighting Time (hh:mm)	Project Name	# of Animal(s)	Est. Distance to Pile (m)	Monitoring Activity Type	Notes
27-Oct-11	11:26-11:36	EHW-1	2	1,360	Pile extraction	<b>Resighting. Considered as a resighting of the same individuals noted during the 09:56 to 10:05 timeframe because the MMO was watching the same location at all times, and MMO notes did not indicate that new individuals arrived on site. Animal was hauled out during pile driving activities.</b>
27-Oct-11	11:47	EHW-1	2	1,360	Between two hammer run times	Resighting. Considered as a resighting of the same individuals noted during the 09:56 to 10:05 timeframe because the MMO was watching the same location at all times, and MMO notes did not indicate that new individuals arrived on site. Animal was hauled out. Hammer was not on during sighting.
27-Oct-11	12:03-12:07	EHW-1	2	1,360	Pile extraction	<b>Resighting. Considered as a resighting of the same individuals noted during the 09:56 to 10:05 timeframe because the MMO was watching the same location at all times, MMO notes did not indicate that new individuals arrived on site. Animal was hauled out during pile driving activities.</b>
<b>TOTAL #OF INDIVIDUALS SIGHTED PER PROJECT</b>					<b>TPP: 6 (NO LEVEL B TAKES)</b>	
					<b>EHW-1: 18 (1 LEVEL B TAKE)</b>	

^First day of marine mammal counts at Delta Pier.

‡Incident represents a level B take; fell within the measured 120 dB RMS behavioral harassment zone for vibratory pile driving

\*First day of Steller sea lion focal follow data collection at Delta Pier.

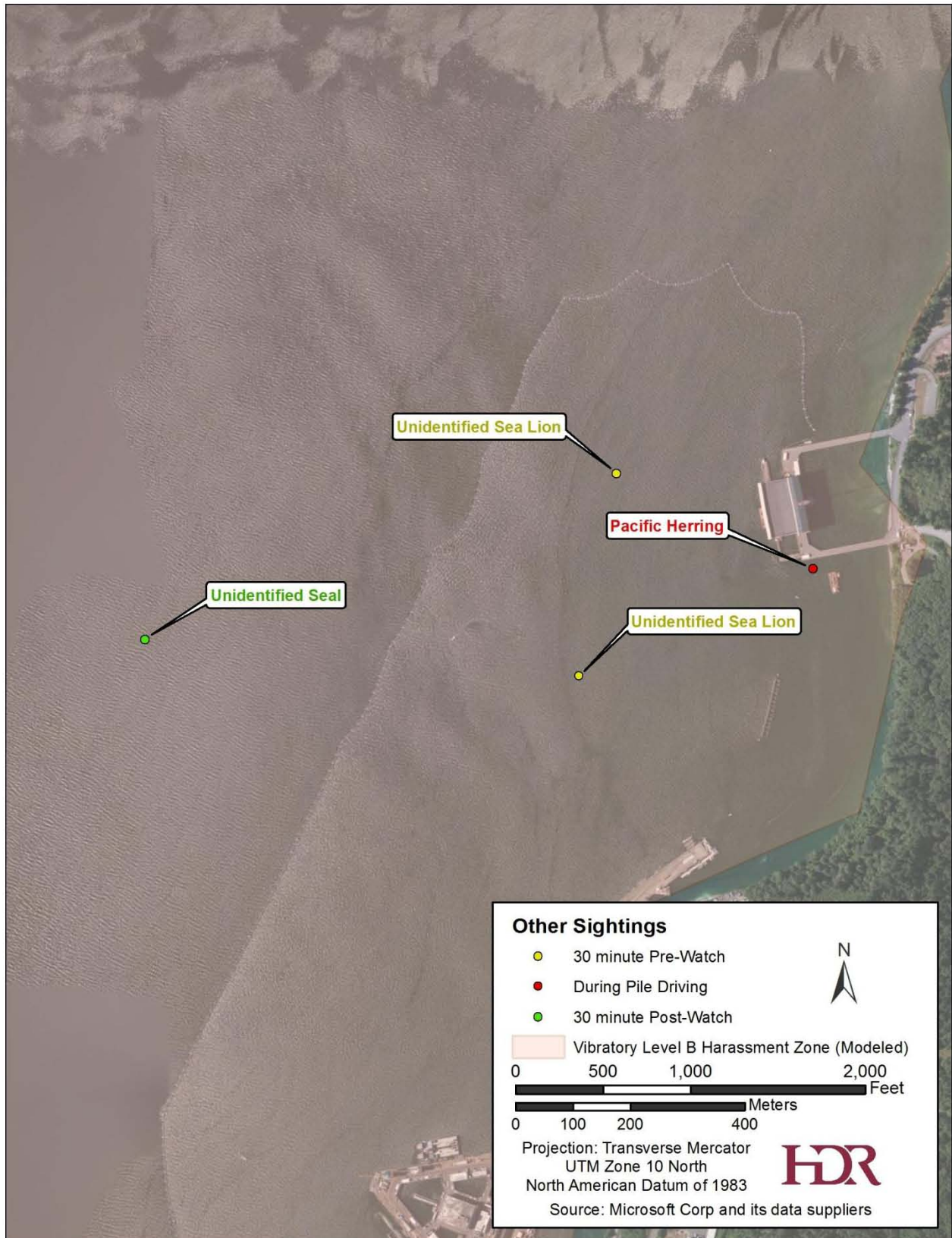


Figure 18. Sightings of Other Marine Species During Pile Driving

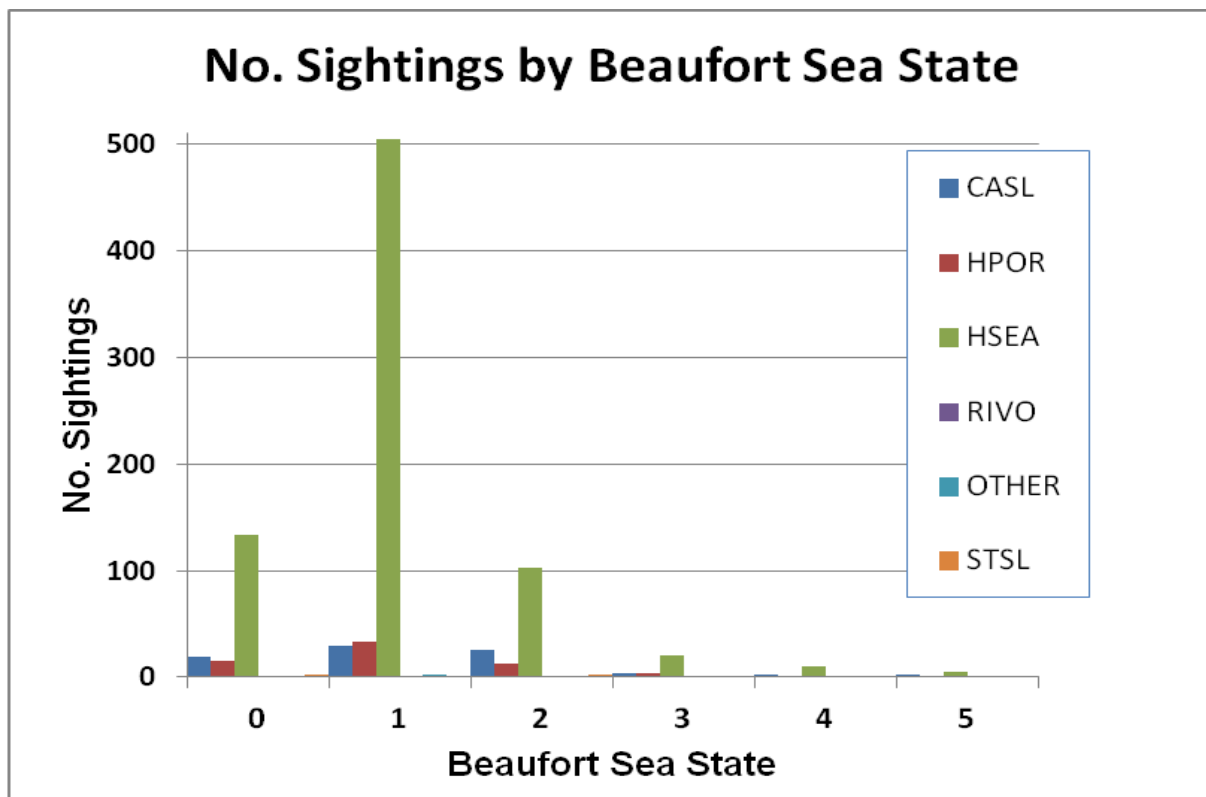


## Marine Mammal Sightings and Environmental Conditions

Perhaps not surprisingly, most marine mammal sightings were made in calm conditions with low wave height (**Figures 19a** and **19b**). Ninety-five percent (887 of a total 937) of marine mammal sightings were made during Beaufort sea state conditions of 0-2 (winds at or below 6 knots) (see **Appendix A** for the Beaufort scale). Marine mammal surveys were conducted during sea states no greater than Beaufort 5 (winds at or below 21 knots). Ninety-three percent (867 of a total of 937) of sightings were made when weather conditions were overcast (OC), partly cloudy (PC), or sunny (S). More marine mammals were observed during partly cloudy and overcast conditions than in sunny conditions, likely because of reduced glare on the water.

## Marine Mammal Behavior During the TPP

**Quantitative Analysis.** Behavioral responses by pinnipeds and cetaceans were recorded before, during, and after construction activities, as well as during non-construction periods. See **Appendix E** for a key to all behavior codes. The only cetacean observed during the TPP was the harbor porpoise. Pinnipeds observed were the harbor seal, California sea lion, and Steller sea lion. Throughout all TPP construction and non-construction (Phases 1 and 2 are combined in all behavioral analyses), cetaceans were most frequently observed traveling ( $n=18$ , 35 percent), swimming ( $n=17$ , 33 percent), and milling ( $n=9$ , 18 percent) (**Figure 20**). During all TPP construction and non-construction activities (Phases 1 and 2 combined), pinnipeds were most frequently observed sinking ( $n=268$ , 25 percent), looking ( $n=256$ , 24 percent), and swimming ( $n=225$ , 21 percent) (**Figure 21**).



**Figure 19a. Number of Sightings by Sea State Condition**

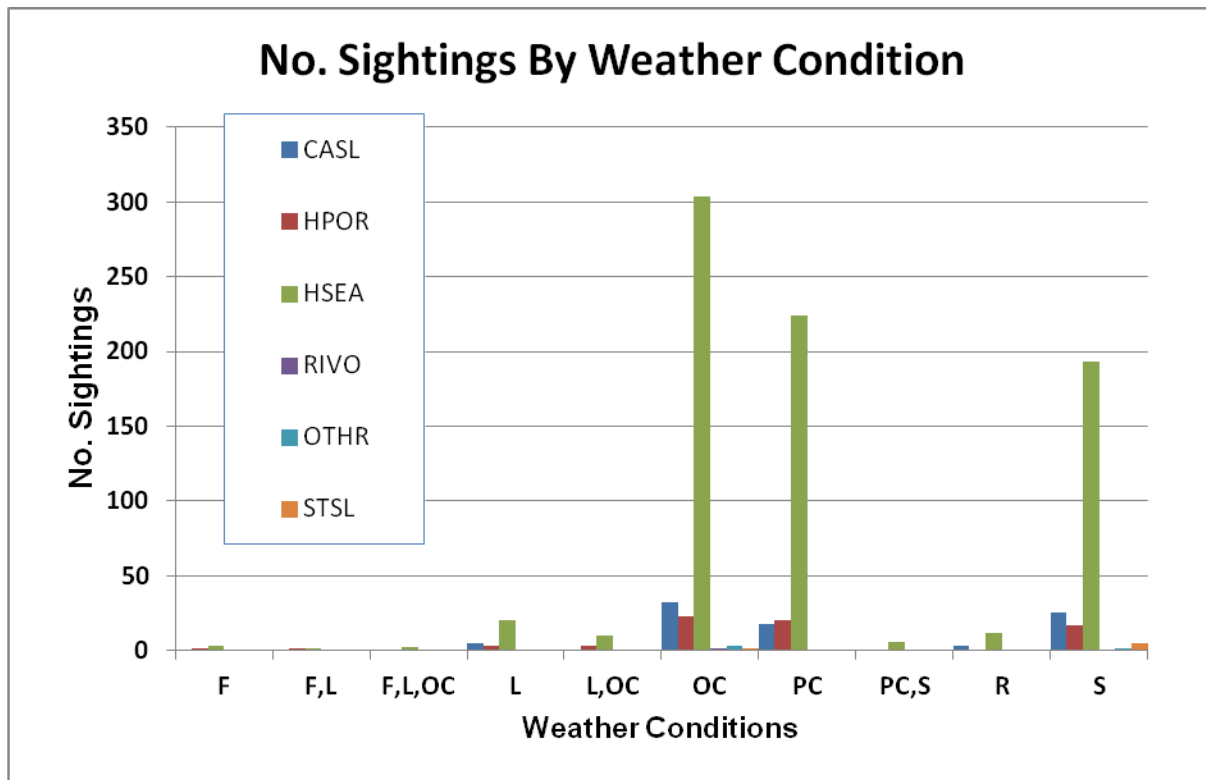


Figure 19b. Number of Sightings by Weather Condition

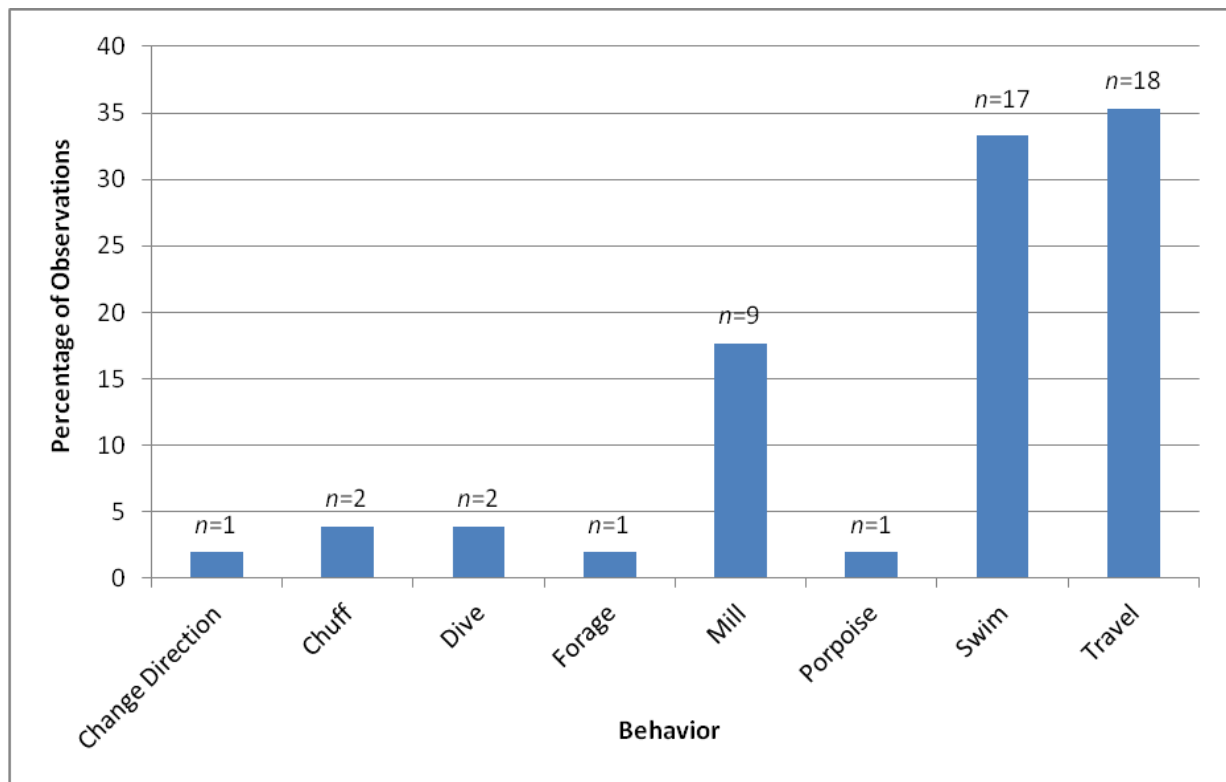
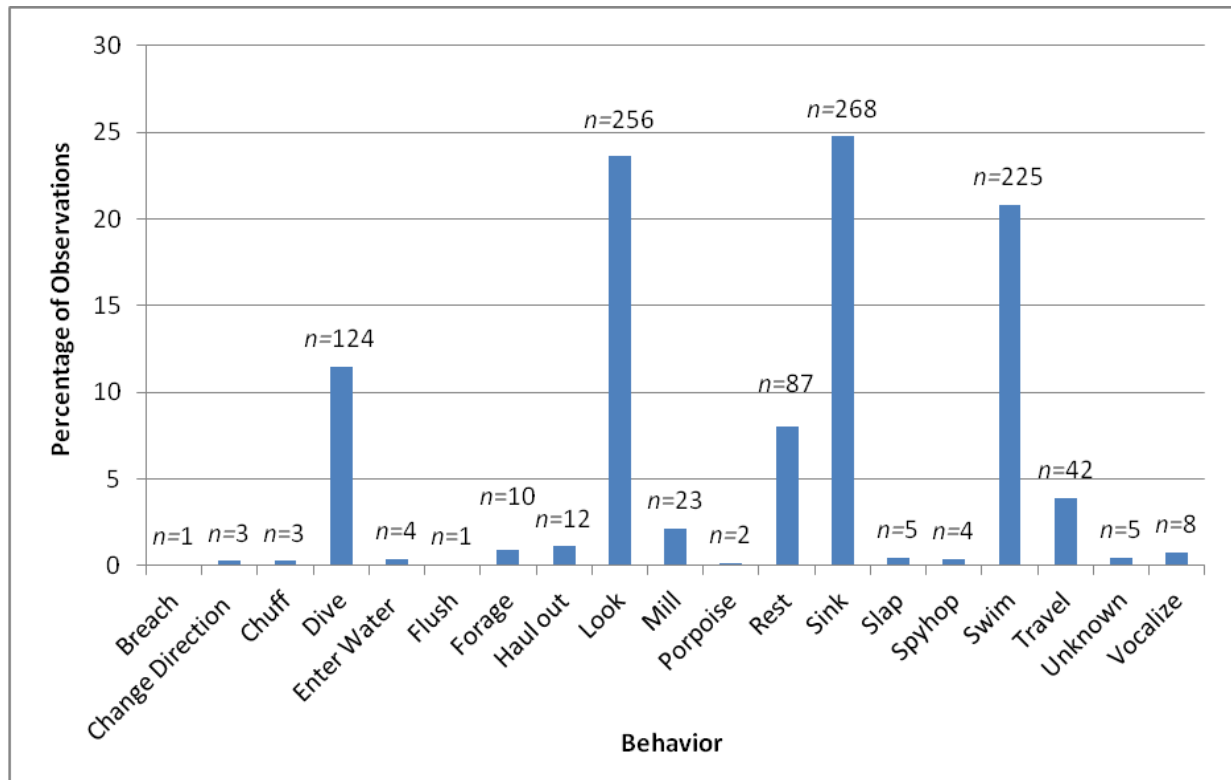


Figure 20. Cetacean Behaviors (Percent of Total) Observed during TPP



**Figure 21. Pinniped Behaviors (Percent of Total) Observed during TPP**

*Analysis of Behavior by Distance from Pile.* Behavior was analyzed as a function of distance from pile for sightings made during construction activities. Distance categories were created to reflect these buffer zones and to permit relevant behavioral comparisons according to measured underwater sound isopleths. All cetacean sightings were made beyond the behavioral buffer zone for impact pile driving (>500 m) and either within the behavioral buffer zone for vibratory pile driving (<6,000 m), or beyond all buffer zones (>6,000 m). The most common cetacean behavior between 501 m and 6,000 m was swimming ( $n=4$  or 57.14 percent), followed by traveling ( $n=3$  or 42.86 percent) (**Table 26**). Changing direction, chuffing, diving, and swimming were each noted once ( $n=1$  or 25 percent) beyond the buffer zone for vibratory pile driving.

Pinnipeds were observed diving, sinking, swimming, and traveling (each  $n=1$  or 25 percent) within 50 m of piles. The most common pinniped behavior recorded between 51 and 500 m of piles was swimming ( $n=25$  or 23 percent) followed by sinking ( $n=23$  or 21 percent) (**Table 27**). The most common pinniped behavior between 501 m and 6,000 m was swimming ( $n=19$  or 10 percent), followed by looking ( $n=17$  or 9 percent). Sinking and swimming were each noted once (each  $n=1$  or 50 percent) beyond the buffer zone for vibratory pile driving. Changing direction, entering water, looking, and resting were most common in the 51 to 500 m category. Fighting, foraging, hauling out, milling, playing, and vocalizing increased at farther distances from construction activities, and pinnipeds were less likely to dive and sink with increasing distance from pile driving.

**Table 26. Comparison of Cetacean Behaviors Observed During Pile Driving Activities Among Distances From Piles during the TPP**

Behavior	Distance from Pile (m)						
	0-50	51-500	501-6,000	>6,000			
	Percent Among Distances Bins [percent (n)]						
Change Direction	0 (0)	End of Shutdown Zone	0 (0)	End of Buffer Zone (for Impact Pile Driving Only)	0 (0)	End of Buffer Zone (for Vibratory Pile Driving)	25.00 (1)
Chuff	0 (0)		0 (0)		0 (0)		25.00 (1)
Dive	0 (0)		0 (0)		0 (0)		25.00 (1)
Swim	0 (0)		0 (0)		57.14 (4)		25.00 (1)
Travel	0 (0)		0 (0)		42.86 (3)		0 (0)

**Table 27. Pinniped Behaviors Observed During Pile Driving Activities by Distance From Pile<sup>1</sup>**

Behavior	Distance from Pile (m)						
	0-50	51-500	501-6,000	>6,000			
	Percent Among Distances Bins [percent (n)]						
Change Direction	0 (0)	End of Shutdown Zone	1.83 (2)	End of Buffer Zone (for Impact Pile Driving Only)	0 (0)	End of Buffer Zone (for Vibratory Pile Driving)	0 (0)
Dive	25.00 (1)*		16.51 (18)		13.21 (7)		0 (0)
Enter Water	0 (0)		1.83 (2)		0 (0)		0 (0)
Fight	0 (0)		0 (0)		1.89 (1)		0 (0)
Forage	0 (0)		0 (0)		1.89 (1)		0 (0)
Haul Out	0 (0)		0 (0)		5.66 (3)		0 (0)
Look	0 (0)		23.85 (26)		20.75 (11)		0 (0)
Mill	0 (0)		1.83 (2)		1.89 (1)		0 (0)
Play	0 (0)		0 (0)		3.77 (2)		0 (0)
Rest	0 (0)		6.42 (7)		5.66 (3)		0 (0)
Sink	25.00 (1)*		21.10 (23)		9.43 (5)		50.00 (1)
Swim	25.00 (1)*		22.94 (25)		18.87 (10)		50.00 (1)
Travel	25.00 (1)*		3.67 (4)		5.66 (3)		0 (0)
Unknown	0 (0)		0 (0)		7.55 (4)		0 (0)
Vocalize	0 (0)		0 (0)		5.66 (3)		0 (0)

<sup>1</sup> Observations in the table only include those activities for which distances to the nearest pile were known. Any observations with unknown distances were not included in the analysis.

\* Animal was observed outside of the injury zone for pinnipeds, and did not constitute a Level A take

*Analysis of Construction Versus Non-Construction Behaviors.* Cetaceans (harbor porpoise) were more likely to travel ( $n=16$  or 31 percent) and swim ( $n=12$  or 24 percent) than during non-construction periods (**Table 28**). A slight decrease (<3 percent) was observed in the percentage of foraging and porpoising cetaceans with construction as compared to non-construction monitoring. The occurrence of milling and traveling decreased (>20 percent) during construction activities in relation to non-construction monitoring. Swimming, chuffing, changing directions, and diving all increased during construction in relation to non-construction monitoring (**Table 28**).

Pinnipeds were more likely to dive during construction ( $n=26$  or 16 percent) than during non-construction periods ( $n=98$  or 11 percent). Other common pinniped behaviors during construction were swimming ( $n=37$  or 22 percent), and looking ( $n=36$  or 22 percent) (**Table 29**). A slight decrease (<3 percent) was observed in the percentage of individuals breaching, chuffing, foraging, looking, milling, porpoising, resting, sleeping, and spyhopping with construction as compared to non-construction monitoring. During construction, there was a slight increase (<2 percent) in the percentage of individuals seen changing direction, entering the water, flushing, hauling out, swimming, traveling, and vocalizing. Occurrence of milling increased (>5 percent) during construction activities in relation to non-construction monitoring, while sinking decreased (>7 percent) (**Table 29**).

**Table 28. Cetacean Behaviors Observed During Construction Versus Non-Construction Periods**

Behavior	Percent of Total ( $n$ )	
	Construction?	
	No	Yes
Change Direction	0 (0)	1.96 (1)
Chuff	1.96 (1)	1.96 (1)
Dive	1.96 (1)	1.96 (1)
Forage	1.96 (1)	0 (0)
Mill	17.65 (9)	0 (0)
Porpoise	1.96 (1)	0 (0)
Swim	23.53 (12)	9.80 (5)
Travel	31.37 (16)	3.9 (2)

**Table 29. Pinniped Behaviors Observed During Construction Versus Non-Construction Periods**

Behavior	Percent of Total ( $n$ )	
	Construction?	
	No	Yes
Breach	0.11 (1)	0 (0)
Change Direction	0.11 (1)	1.20 (2)
Chuff	0.33 (3)	0 (0)

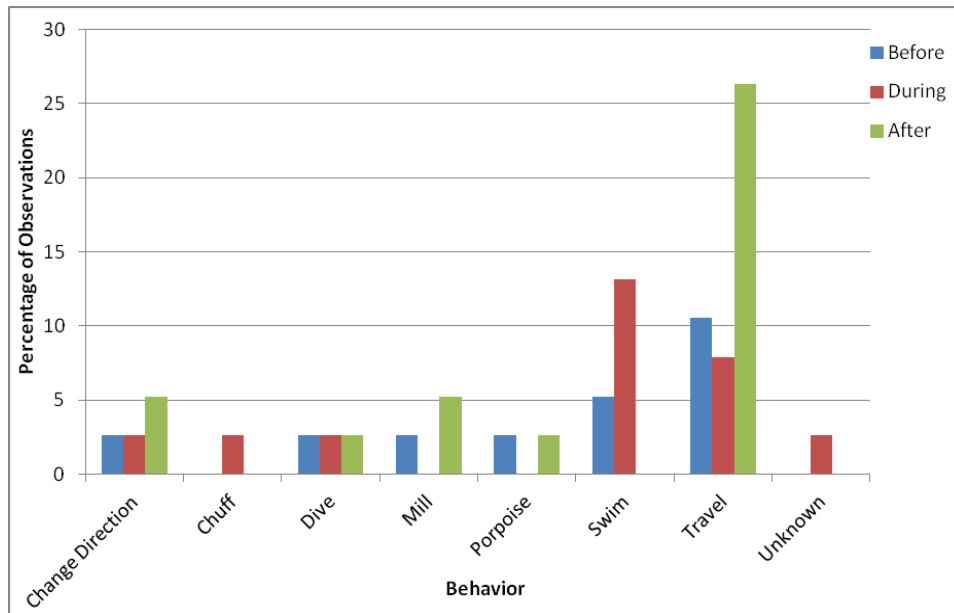


Behavior	Percent of Total ( <i>n</i> )	
	Construction?	
	No	Yes
Dive	10.66 (98)	15.66 (26)
Enter Water	0.22 (2)	1.20 (2)
Flush	0 (0)	0.60 (1)
Forage	0.98 (9)	0.60 (1)
Haul Out	0.98 (9)	1.81 (3)
Look	24.15 (222)	21.69 (36)
Mill	2.18 (20)	1.81 (3)
Porpoise	0.22 (2)	0 (0)
Rest	8.38 (77)	6.02 (10)
Sink	25.90 (238)	18.07 (30)
Slap	0.54 (5)	0 (0)
Spyhop	0.44 (4)	0 (0)
Swim	20.46 (188)	22.29 (37)
Travel	3.70 (34)	4.82 (8)
Unknown	0.11 (1)	2.41 (4)
Vocalize	0.54 (5)	1.81 (3)

*Analysis of Behavioral Observations Made Before, During, and After Construction.* The most common cetacean behavior before pile driving activities was traveling ( $n=4$  or 11 percent), followed by swimming ( $n=2$  or 5 percent) (Table 30, Figure 22). During pile driving, cetaceans were most often observed swimming ( $n=5$  or 13 percent), followed by traveling ( $n=3$  or 8 percent). After pile driving activities, cetaceans were observed traveling ( $n=10$  or 26 percent), followed by milling ( $n=2$  or 5 percent) and changing direction ( $n=2$  or 5 percent). Occurrence of swimming behaviors decreased post-construction in relation to pre-construction. Milling, traveling and changing direction increased post-construction in relation to pre-construction. Chuffing, swimming and unknown behaviors increased during construction (Table 28, Figure 22).

**Table 30. Cetacean Behaviors Observed Before, During, and After Pile Driving Activities**

Behavior	Percent of Total ( <i>n</i> )		
	Before	During	After
Change Direction	2.63 (1)	2.63 (1)	5.26 (2)
Chuff	0 (0)	2.63 (1)	0 (0)
Dive	2.63 (1)	2.63 (1)	2.63 (1)
Mill	2.63 (1)	0 (0)	5.26 (2)
Porpoise	2.63 (1)	0 (0)	2.63 (1)
Swim	5.26 (2)	13.16 (5)	0 (0)
Travel	10.53 (4)	7.89 (3)	26.32 (10)
Unknown	0 (0)	2.63 (1)	0 (0)



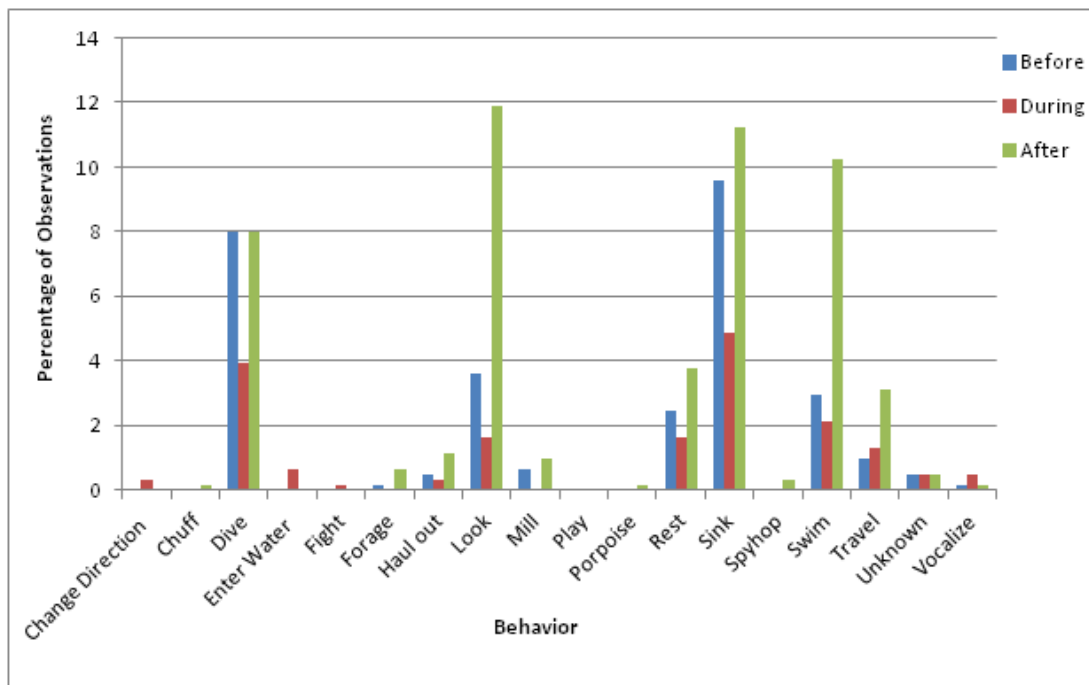
**Figure 22. Cetacean Behaviors Observed Before, During, and After Pile Driving**

Pinnipeds were most commonly seen sinking ( $n=59$  or 10 percent), followed by diving ( $n=49$  or 8 percent), looking ( $n=22$  or 4 percent), and swimming ( $n=18$  or 3 percent) before pile driving activities (**Table 31, Figure 23**). During pile driving activities, pinnipeds were observed sinking ( $n=30$  or 5 percent), followed by diving ( $n=24$  or 4 percent), swimming ( $n=13$  or 2 percent), looking ( $n=10$  or 2 percent), and resting ( $n=10$  or 2 percent). After pile driving activities, pinnipeds were most commonly seen looking ( $n=73$  or 12 percent), followed by sinking ( $n=69$  or 11 percent), swimming ( $n=63$  or 10 percent), diving ( $n=49$  or 8 percent), and resting ( $n=23$  or 4 percent). Occurrence of changing directions, hauling out, flushing and entering the water behaviors decreased post-construction in relation to pre-construction. Most behaviors increased post-construction in relation to pre-construction, such as swimming, traveling, milling, resting, and looking. Changing direction, entering the water, flushing traveling, and vocalizing behaviors increased during construction (**Table 31, Figure 23**).

**Table 31. Pinniped Behaviors Observed Before, During, and After Pile Driving Activities**

Behavior	Percent of Total (n)		
	Before	During	After
Change Direction	0 (0)	0.33 (2)	0 (0)
Chuff	0 (0)	0 (0)	0.16 (1)
Dive	7.99 (49)	3.91 (24)	7.99 (49)
Enter Water	0 (0)	0.65 (4)	0 (0)
Fight	0 (0)	0.16 (1)	0 (0)
Forage	0.16 (1)	0 (0)	0.65 (4)
Haul Out	0.49 (3)	0.33 (2)	1.14 (7)
Look	3.58 (22)	1.63 (10)	11.89 (73)

Behavior	Percent of Total (n)		
	Before	During	After
Mill	0.65 (4)	0 (0)	0.98 (6)
Play	0 (0)	0 (0)	0 (0)
Porpoise	0 (0)	0 (0)	0.16 (1)
Rest	2.44 (15)	1.63 (10)	3.75 (23)
Sink	9.61 (59)	4.89 (30)	11.24 (69)
Spyhop	0 (0)	0 (0)	0.33 (2)
Swim	2.93 (18)	2.11 (13)	10.26 (63)
Travel	0.98 (6)	1.30 (8)	3.09 (19)
Unknown	0.49 (3)	0.49 (3)	0.49 (3)
Vocalize	0.16 (1)	0.49 (3)	0.16 (1)

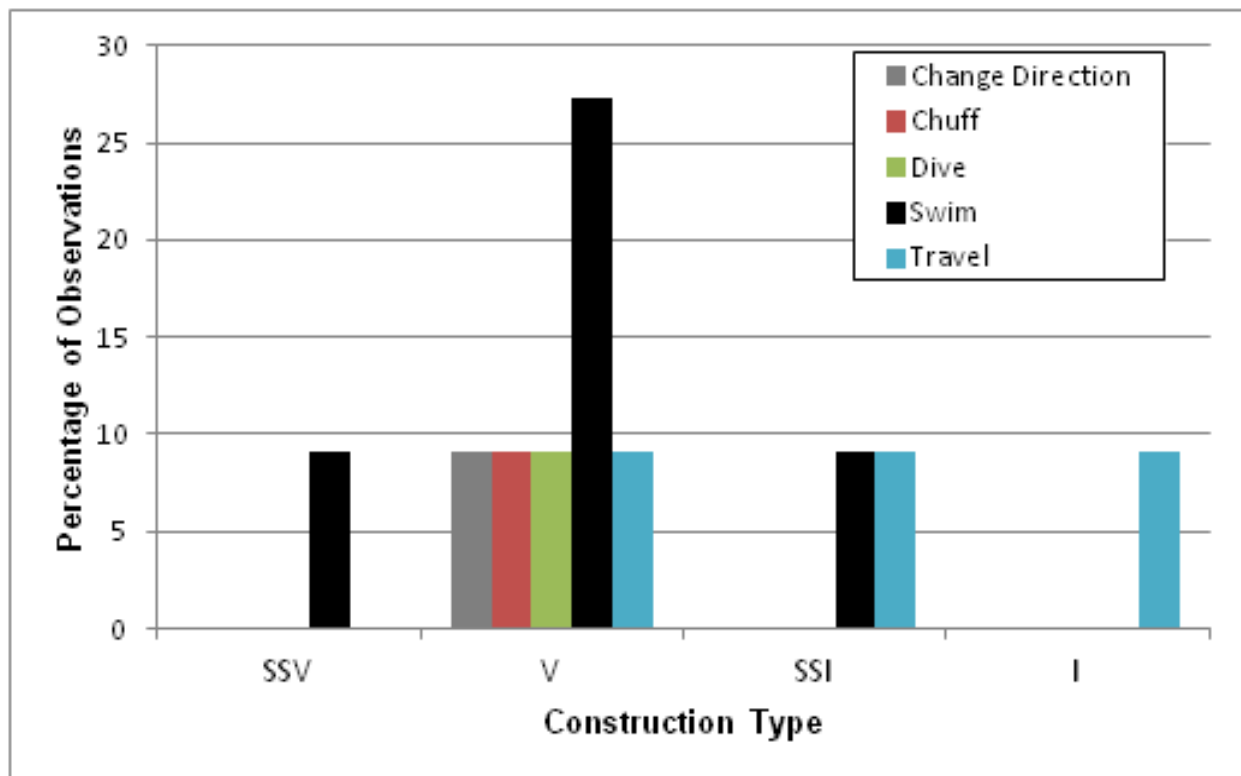


**Figure 23. Pinniped Behaviors Observed Before, During, and After Pile Driving Activities**

*Analysis of Behavior by Construction Type.* Behavioral patterns were compared for vibratory and impact pile driving, as well as for soft start procedures associated with each. Only one harbor porpoise was observed during impact driving, only one harbor porpoise was seen during a vibratory soft start (**Table 32**). The animal observed during impact driving traveling, and that seen during a vibratory soft start was swimming. During vibratory pile driving, cetaceans (harbor porpoise) were most often observed swimming ( $n=3$  or 27 percent) (**Figure 24**). Two animals were observed during impact soft starts, one swimming and one traveling (**Figure 24**).

**Table 32. Cetacean Behaviors by Construction Type**

Behavior	Percent of Total (n)			
	Vibratory (Soft Start)	Vibratory	Impact (Soft Start)	Impact
Change Direction	0 (0)	9.09 (1)	0 (0)	0 (0)
Chuff	0 (0)	9.09 (1)	0 (0)	0 (0)
Dive	0 (0)	9.09 (1)	0 (0)	0 (0)
Swim	9.09(1)	27.27 (3)	9.09(1)	0 (0)
Travel	0 (0)	9.09(1)	9.09 (1)	9.09 (1)



**Figure 24. Cetacean Behavior by Construction Type**

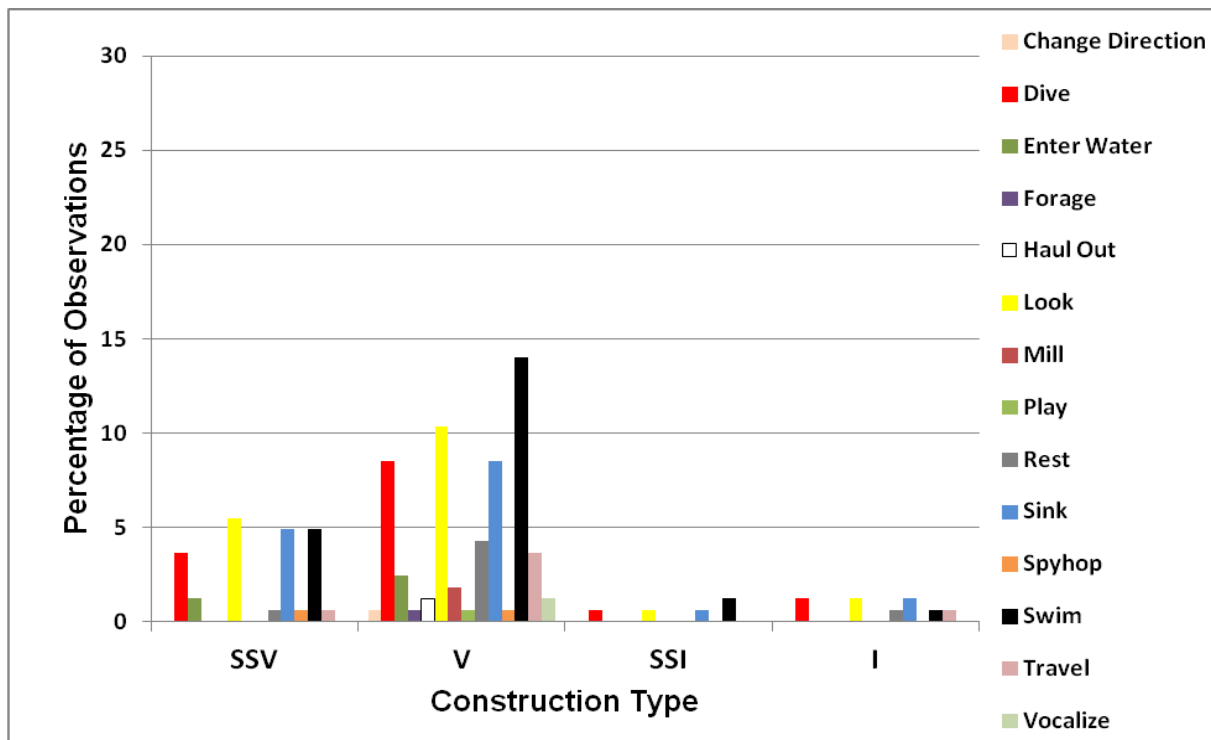
During vibratory soft start procedures, pinnipeds were most commonly seen looking ( $n=9$  or 5.5 percent), followed by swimming ( $n=8$  or 5 percent) and sinking ( $n=8$  or 5 percent) (Table 33, Figure 25). During impact soft starts, pinnipeds were most often observed swimming ( $n=2$  or 1 percent). During impact pile driving, pinnipeds were primarily observed diving, looking and sinking (each with  $n=2$  or 1 percent). Changing directions, foraging, milling, playing, and vocalizing were only observed during vibratory pile driving; however, there were only between one and three sightings for each of these behaviors during the entire monitoring effort (Table 33, Figure 25).

**Table 33. Percent and Number of Pinniped Behaviors Observed by Construction Type**

Behavior	Percent of Total (n)			
	Vibratory (Soft Start)	Vibratory	Impact (Soft Start)	Impact
Change Direction	0 (0)	0.61 (1)	0 (0)	0 (0)
Dive	3.66 (6)	8.54 (14)	0.61 (1)	1.22 (2)
Enter Water	1.22 (2)	2.44 (4)	0 (0)	0 (0)
Forage	0 (0)	0.61 (1)	0 (0)	0 (0)
Haul Out	0 (0)	1.22 (2)	0 (0)	0 (0)
Look	5.49 (9)	9.76 (17)	0.61 (1)	1.22 (2)
Mill	0 (0)	1.83 (3)	0 (0)	0 (0)
Play	0 (0)	0.61 (1)	0 (0)	0 (0)
Rest	0.61 (1)	4.27 (7)	0 (0)	0.61 (1)
Sink	4.88 (8)	8.54 (23)	0.61 (1)	1.22 (2)
Spyhop	0.61 (1)	0.61 (1)	0 (0)	0 (0)
Swim	4.88 (8)	14.02 (23)	1.22 (2)	0.61 (1)
Travel	0.61 (1)	3.66 (6)	0 (0)	0.61 (1)
Vocalize	0 (0)	1.22 (2)	0 (0)	0 (0)

**Summary of Quantitative Analysis.** Because of the relatively small number of harbor porpoise observed during pile driving events, no clear cetacean behavior patterns emerged with distance from pile. Pinnipeds were more likely to fight, forage, haul out, mill, play and vocalize as distance to the pile increased. Pinnipeds were more likely to dive and sink when closer to pile driving activity. There was a slight decrease in cetacean and pinniped foraging behaviors during construction as compared to non-construction periods. Both cetaceans and pinnipeds were more likely to change direction while traveling during construction, and pinnipeds were slightly more likely to enter the water, flush, haul out, and vocalize during construction. Cetaceans were most commonly observed traveling before, during and after construction, and a slight decrease in traveling activity was observed during construction as opposed to just before and just after construction. Pinnipeds most commonly dove, looked, sank and swam in conjunction with construction activities. A general decrease in these activities was noted during actual construction, as opposed to just before and after construction periods. Pinnipeds were more likely to look, sink and travel just after construction as opposed to just before construction.





**Figure 25. Pinniped Behaviors by Construction Type**

Cetaceans were equally likely to engage behaviors during various types of construction with the exception of vibratory pile driving, when they were more often observed swimming. Pinnipeds were more often observed swimming during impact soft start procedures than during other types of construction. In general, more behavior categories were observed during vibratory pile driving, likely because this type of pile driving lasted longer than the other types of pile driving, providing more opportunities to observe marine mammal behavior. Vibratory drives lasted between 4 and 26 minutes, and all impact drives lasted less than two minutes. Most soft start events occurred over a 3-minute timeframe. Therefore, there was typically more time to collect marine mammal observations during vibratory drives than during impact drives or soft starts of either type.

**Qualitative Behavioral Observations.** In addition to the quantitative results presented here, MMOs made a number of qualitative observations on the movements and distribution of animals, and on the potential effects of pile driving activities on marine mammal behavior during the TPP. In the open water areas where pile driving for TPP was conducted, almost all animals observed were in transit, generally moving along a north-south axis parallel to the shoreline. These animals either rarely lingered, or conducted active foraging near the pile driving equipment. In addition, on several occasions large groups of animals, both harbor seals and California sea lions, were seen moving northward from the Marginal Wharf toward the EHW-1 structure within approximately 50 m from shore. Aside from these larger groups, observations of pinnipeds were generally of single animals, of which the majority (>80 percent) were harbor seals.

Observers noted differences between the open water areas monitored for the TPP and, for example, the semi-enclosed EHW-1 structure. During the TPP, both cetaceans and pinnipeds

were seldom observed within the 50 m shutdown zone, or within 100 or 200 m of the pile driving activity, for long periods of time. Animals that were observed in this area appeared to transit through the area with no change in behavior. MMOs noted four instances in which pinnipeds dove in response to the initiation of pile driving and later surfaced at a greater distance away and continued transiting. In summary, MMOs generally felt that the behaviors of harbor seals and California sea lions did not indicate adverse reaction to TPP construction activities. The only observations made of cetaceans in conjunction with the onset of vibratory soft start events were traveling behaviors where no obvious behavioral changes were observed. MMOs generally noted that pinnipeds did not change their behavior with the onset of vibratory soft start events. Pinnipeds were occasionally noted diving in conjunction with the onset of soft start events, then reemerged further away and continued their movements. This is consistent with the quantitative analysis (**Table 29**).

## Section 4 Recommendations

---

1. In order to obtain more accurate and reliable data from future bubble curtain on/off tests, we recommend that (a) at least 30 hammer strikes be employed for each test, in order to obtain sufficient sound attenuation data and allow the hammer sufficient “warm up” time; (b) each on/off test be performed on the same pile, not different piles, and (c) predicted unattenuated sound levels for each pile be reported and compared to actual attenuated sound levels (“bubble on”) in addition to comparison with actual attenuated levels (“bubble off”).
2. Observational data during the TPP did not indicate any adverse reaction of marine mammals to pile driving activities, particularly during vibratory events. The harbor seal, which is the species that most heavily uses the WRA, in particular the EHW-1 structure, did not appear to be affected by construction as it often came in the closest to investigate activities. Based on these observational data collected during TPP (and to an extent EHW-1) the 50 m shutdown zone used for all marine mammals may be overly conservative. In addition, we recommend having different shutdown zones for pinnipeds and cetaceans. Injury thresholds are different for these species, as is their use of the nearshore areas (i.e. inside the WRA) at NBK at Bangor.
3. The 1-minute pauses in between soft start sounds employed during this project may have been too long to send an effective warning to animals in the area. Longer breaks between the sounds may be interpreted by the animals as a transient sound, and may not serve the intended purpose to provide an indication that louder sounds from pile driving are about to begin. Recommend that sound bursts during soft start events occur at 30-second intervals and with increasing intensity, as they do in seismic surveys, for example. Soft start pauses should at least be shortened to 30 seconds, even if sound levels remain the same throughout the soft start event.
4. Because of the substantial effort and cost of monitoring the entire Hood Canal area, future monitoring efforts might effectively be confined to the shutdown zones and adjacent areas (i.e., inside the WRA fence) to document behavioral impacts to marine mammals.
5. Steller sea lion takes should be included in permits for future construction projects on Hood Canal.
6. No Dall's porpoise or transient killer whales were observed during the duration of the TPP. In addition, recent findings indicate that Dall's porpoise are being sighted less frequently and harbor porpoises are sighted more frequently throughout Puget Sound, which may indicate a trend towards fewer of these animals in the Hood Canal region. Further detailed analysis of harbor porpoise density should be completed to provide updates to current available data.

---

## Section 5 Acknowledgements

---

Thanks are due to Andrea Balla-Holden (NAVFAC NW) for support and organization of monitoring efforts; lead boat captain Lou Schwartz (Tetra Tech, Inc.), monitoring coordinators Jeff Barrett and Jason Stutes (Hart Crowser), acousticians James Reyff, Keith Pommerenck and Rich Rodkin (Illingworth and Rodkin), Todd McConchie (HDR) for database management and data QA/QC, and Catherine Bacon (HDR) for assisting with report preparation.

---

## Section 6 List of Preparers

---

Kristen Ampela, PhD  
HDR  
Project Manager and Chief Scientist/Author

Todd McConchie  
HDR  
Observer/Data Analyst/Author

Cathy Bacon  
HDR  
Observer/Data Analyst/Author

Christopher McJeters  
HDR  
Technical Reviewer

Phil Thorson, PhD  
HDR  
Technical Reviewer

Cheryl Myers  
HDR  
Document Formatting and Production

## Section 7 References

---

- Buckland, S. T., Anderson, D. R., Burnham, K. P., Laake, J. L., Borchers, D. L., and Thomas, L. 2001. An Introduction to Distance Sampling, Oxford: Oxford University Press.
- DoN (Department of Navy) 2011. Final Environmental Assessment. Explosives Handling Wharf 1 Pile Replacement Project Naval Base Kitsap at Bangor Silverdale WA. Submitted to National Marine Fisheries Service, Silver Spring, Maryland.
- Eder, T., and I. Sheldon. 2001. Whales and Other Marine Mammals of Washington and Oregon. Lone Pine Publishing. 144 pp.
- Illingworth & Rodkin Inc. 2012. Naval Base Kitsap at Bangor Test Pile Program, Bangor, Washington. Draft Marine Acoustic Monitoring Report. Prepared for HDR Inc., San Diego, CA and Naval Facilities Engineering Northwest, Silverdale, WA. February 2012.
- Hart Crowser Inc. 2012. Naval Base Kitsap at Bangor Test Pile Program, Bangor, Washington. Draft Final Marbled Murrelet Monitoring Report. Prepared for HDR Inc., San Diego, CA and Naval Facilities Engineering Northwest, Silverdale, WA. January 2012.
- NMFS (National Marine Fisheries Service). 1997. Investigation of Scientific Information on the Impacts of California Sea Lions and Pacific Harbor Seals on Salmonids and on the Coastal Ecosystems of Washington, Oregon, and California. U.S. Dep. Commer., NOAA Tech. Memo. NMFS-NWFSC-28, 172 p.
- NMFS (National Marine Fisheries Service). 2011. Incidental Harassment Authorization to Naval Base Kitsap Bangor to harass marine mammals incidental to a test pile program in the Hood Canal, Washington. Issued June 24, 2011.
- NMFS (National Marine Fisheries Service). 2011. Incidental Harassment Authorization to Naval Base Kitsap Bangor to harass marine mammals incidental to a test pile program in the Hood Canal, Washington. *Revised*. Issued October 18, 2011.
- USFWS (U.S. Fish and Wildlife Service). 2011. Test Pile Program at Naval Base Kitsap Bangor Endangered Species Act Section 7 Consultation regarding anticipated adverse effects from the proposed action on the marbled murrelet - Additional Clarification. Issued May 11, 2011.



**APPENDIX A**  
**U.S. Navy Test Pile Program in Hood Canal**  
**Final Marine Mammal Monitoring Plan**

---

*U.S. Navy Test Pile Program  
In Hood Canal*

**FINAL MARINE MAMMAL MONITORING PLAN**

*May 2011*

---

## TABLE OF CONTENTS

1.0	INTRODUCTION .....	1
2.0	ACTION AREA.....	1
3.0	METHODOLOGY .....	7
3.1	OBSERVER QUALIFICATIONS .....	7
3.2	DATA COLLECTION .....	7
3.3	EQUIPMENT .....	7
3.4	SHUTDOWN AND BUFFER ZONES.....	8
3.5	OBSERVER MONITORING LOCATIONS .....	9
3.6	MONITORING TECHNIQUES.....	14
3.6.1	Visual Survey Protocol – Pre-Activity Monitoring .....	14
3.6.2	Visual Survey Protocol – During Activity Monitoring.....	15
3.6.3	Visual Survey Protocol – Post-Activity Monitoring.....	15
3.6.4	Acoustic Measurements .....	16
4.0	INTERAGENCY NOTIFICATION.....	16
5.0	MONITORING REPORT .....	16

### LIST OF FIGURES

Figure 1.	Test Pile Program Action Area.....	2
Figure 2.	Distance to NMFS Underwater Noise Thresholds for Cetaceans .....	3
Figure 3.	Distance to NMFS Underwater Noise Thresholds for Pinnipeds.....	4
Figure 4.	Distance to NMFS Airborne Noise Thresholds for Pinnipeds .....	5
Figure 5.	Distance to NMFS Airborne Noise Thresholds for Harbor Seals .....	6
Figure 6.	Near-Field Monitoring Locations within the NMFS Underwater Noise Thresholds for Marine Mammals from Impact and Vibratory Pile Installation/ Removal Activities .....	11
Figure 7.	Survey Tracklines of the North and South Monitoring Vessels Depicted for Several Pile Locations During Impact Pile Driving for Marbled Murrelet Monitoring.....	12
Figure 8.	Far-Field Marine Mammal Monitoring Locations within the NMFS Noise Thresholds for Impact and Vibratory Pile Installation Activities.....	13

### APPENDIX

- APPENDIX A: Marine Mammal Sighting Form
- APPENDIX B: Beaufort Wind Scale
- APPENDIX C: Chain of Custody Form

---

## NAVY TEST PILE PROGRAM MARINE MAMMAL MONITORING PLAN

---

### 1.0 INTRODUCTION

The purpose of this survey plan is to monitor for the presence of marine mammals in the vicinity of the proposed Test Pile Program at the Naval Base Kitsap (NBK) at Bangor, WA waterfront. These surveys will be conducted before, during, and after pile driving and removal activities, within the areas that are estimated to be encompassed by the airborne and underwater injury or behavioral disturbance thresholds. Real-time acoustic monitoring (see Navy's Acoustic Monitoring Plan) will be used to determine the distances to the injury and behavioral disturbance zone isopleths and the visual marine mammal monitoring survey protocols will be adjusted accordingly (either larger or smaller survey areas) to encompass the actual zones of influence.

### 2.0 ACTION AREA

*The action area includes "all areas to be affected directly or indirectly by the federal action and not merely the immediate area involved in the action" (50 CFR § 402.02). Specifically, the action area is defined as the geographic extent of physical, biological, and chemical effects of the action above baseline conditions. The action area boundary takes into account how the action's physical, chemical, and biotic effects (stressors) move across the landscape, through direct and indirect pathways, over time, to identify the spatial and temporal scale of the action area (USDI et al. 2008; ODOT 2006; WSDOT 2008).*

Underwater noise from vibratory pile driving was the stressor identified to have the furthest geographic distribution above ambient conditions. The Test Pile Program will generate both airborne and underwater sound from impact and vibratory pile driving. To determine which noise effect extended the furthest, attenuation was modeled and compared to ambient levels. The ambient noise levels at NBK at Bangor were previously measured over a one month period in the summer of 2007 (July 10 – Aug 14) (Slater 2009). No other baseline underwater noise measurements have been taken at NBK at Bangor. The underwater sound measurements were conducted at several locations in the vicinity of the project area. The location closest to the project area, designated as Marginal Wharf in the report, recorded data from two hydrophones deployed 300-500 feet north of the Marginal Wharf. Recordings were made 5 minutes per hour throughout the entire study period (Slater 2009). Average underwater broadband ambient noise levels near the project site were 114 dB RMS re at 1 microPascal (dB re 1 $\mu$ Pa) between 100 hertz (Hz) and 20 kilohertz (kHz). Airborne noise levels at the NBK at Bangor waterfront in the daytime ranged between 60 and 104 dBA (decibels in the A-weighted scale) and averaged 64 dBA; night levels ranged between 64 and 96 dBA, averaging 64 dBA, consistent with other urbanized environments where equipment is operating.

Using the practical spreading loss model for transmission (15 log), it was determined that underwater sound from vibratory pile driving was the stressor identified to have the furthest geographic distribution to be distinguishable above ambient conditions. Sound generated from vibratory pile driving would intersect land masses (e.g., Toandos Peninsula) prior to attenuating to measured background levels. As such, the geographic boundary of the Action Area was defined by the line-of-sight intersection of land and water and is shown on Figure 1.

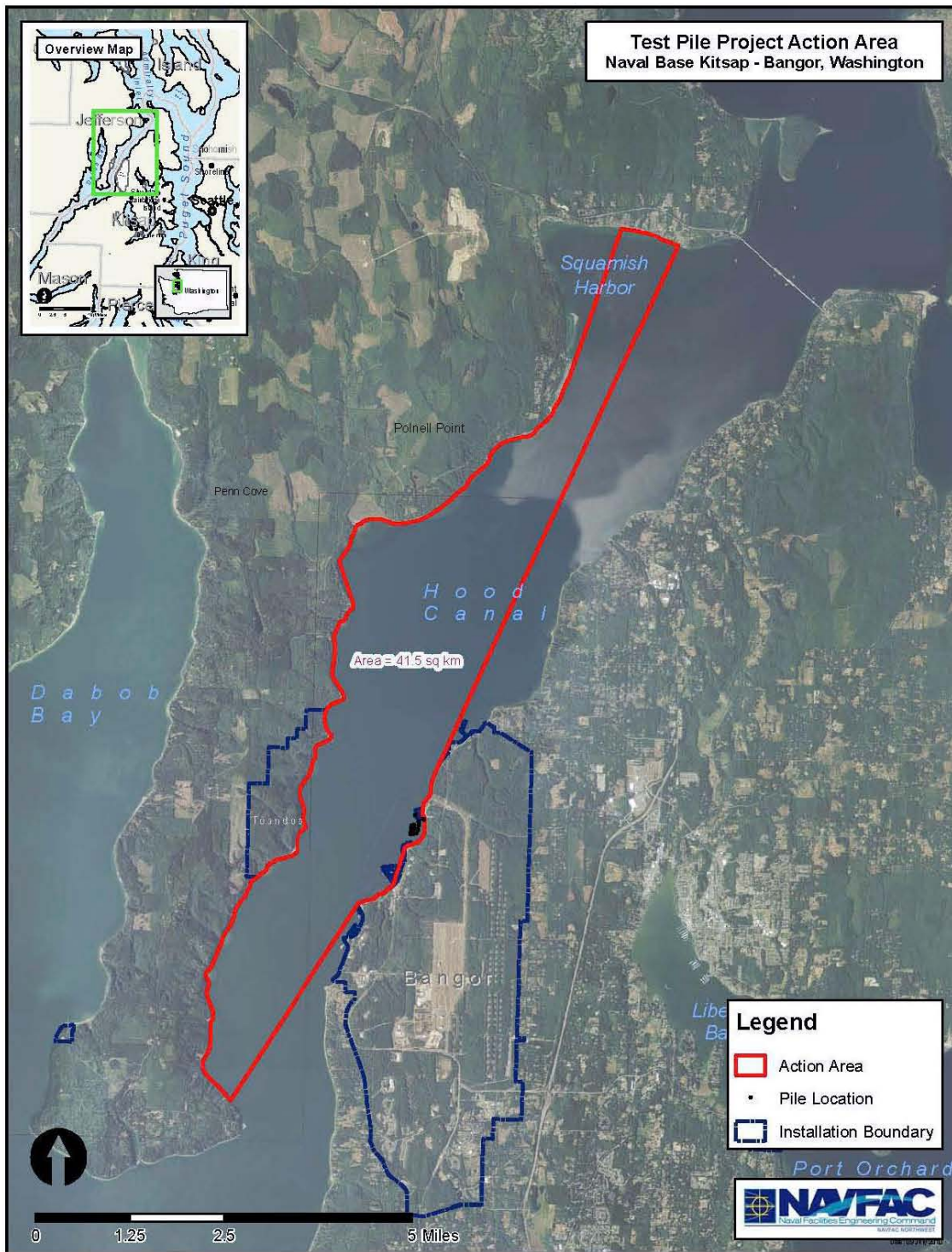


Figure 1. Test Pile Program Action Area

U.S. Navy Test Pile Program in Hood Canal  
MARINE MAMMAL MONITORING PLAN  
May 2011



The distances to and the area encompassed by the underwater noise thresholds for cetaceans from impact and vibratory pile driving/removal are shown in Figure 2.

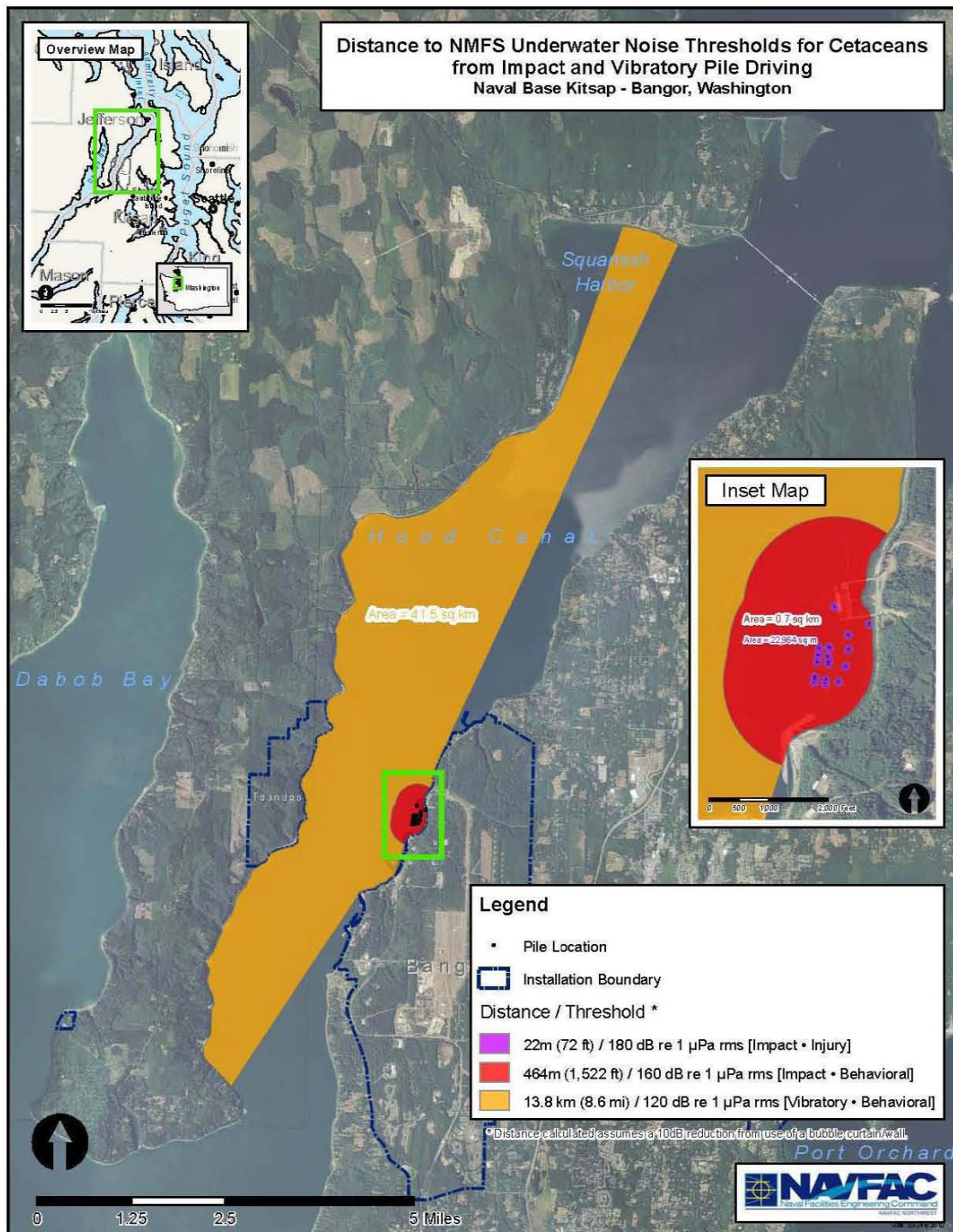


Figure 2. Distance to NMFS Underwater Noise Thresholds for Cetaceans

U.S. Navy Test Pile Program in Hood Canal  
MARINE MAMMAL MONITORING PLAN  
May 2011

The distances to and the area encompassed by the underwater noise thresholds for pinnipeds from impact and pile driving activities are shown in Figure 3.

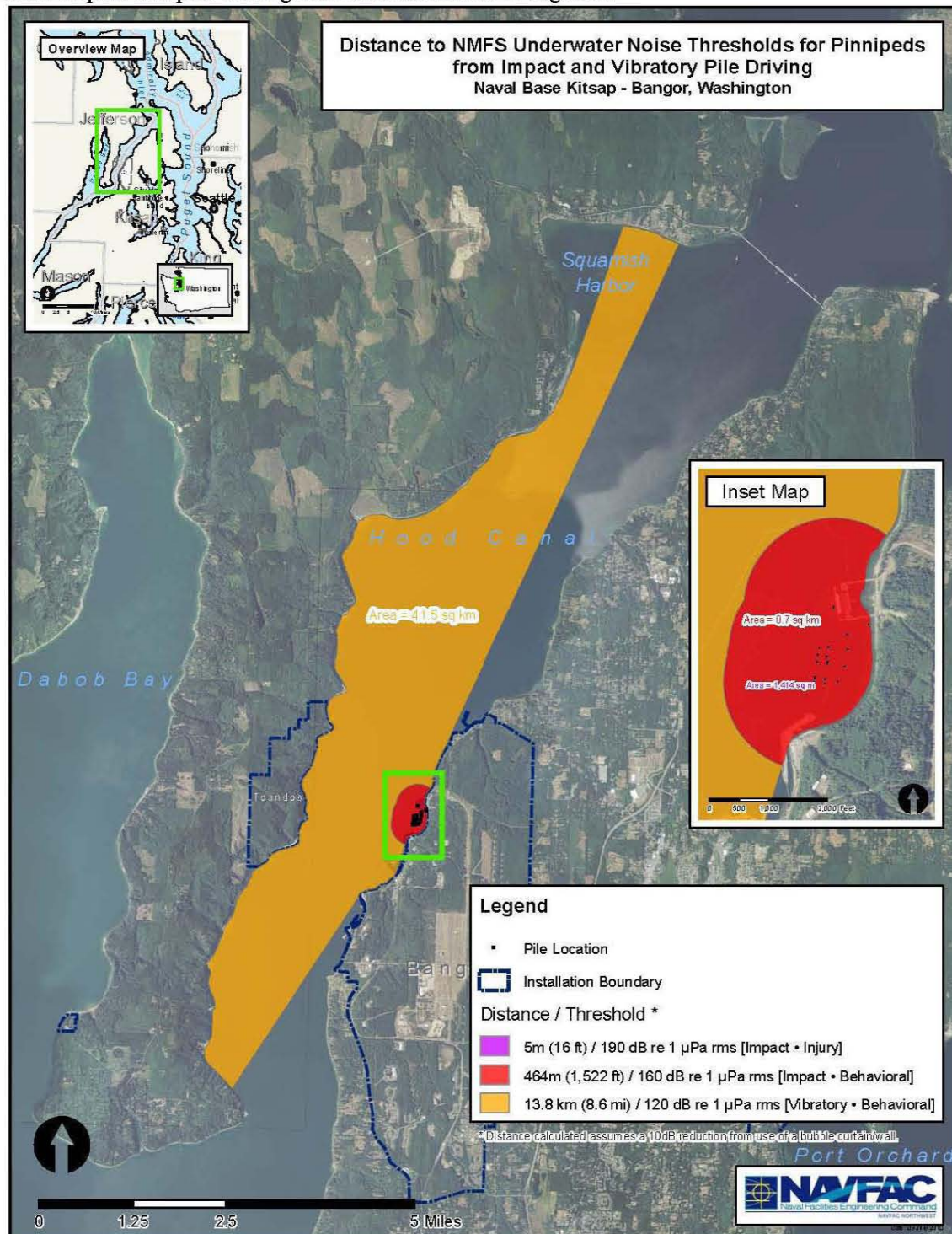


Figure 3. Distance to NMFS Underwater Noise Thresholds for Pinnipeds

U.S. Navy Test Pile Program in Hood Canal  
MARINE MAMMAL MONITORING PLAN  
May 2011



Figures 4 and 5 indicate the airborne noise thresholds for harbor seals and other pinnipeds, respectively, from impact and vibratory pile driving/removal.

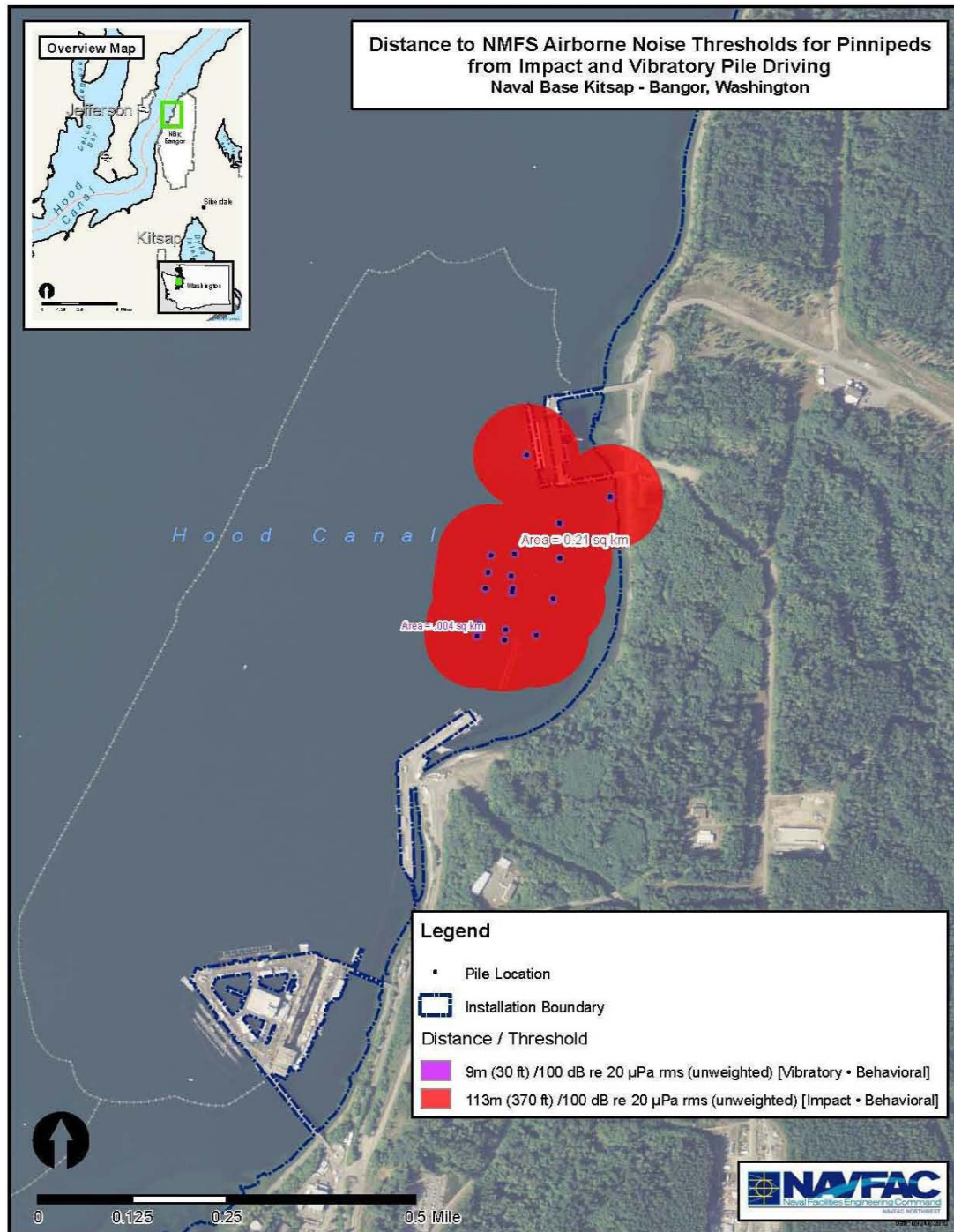


Figure 4. Distance to NMFS Airborne Noise Thresholds for Pinnipeds (not including harbor seals)

U.S. Navy Test Pile Program in Hood Canal  
MARINE MAMMAL MONITORING PLAN  
May 2011

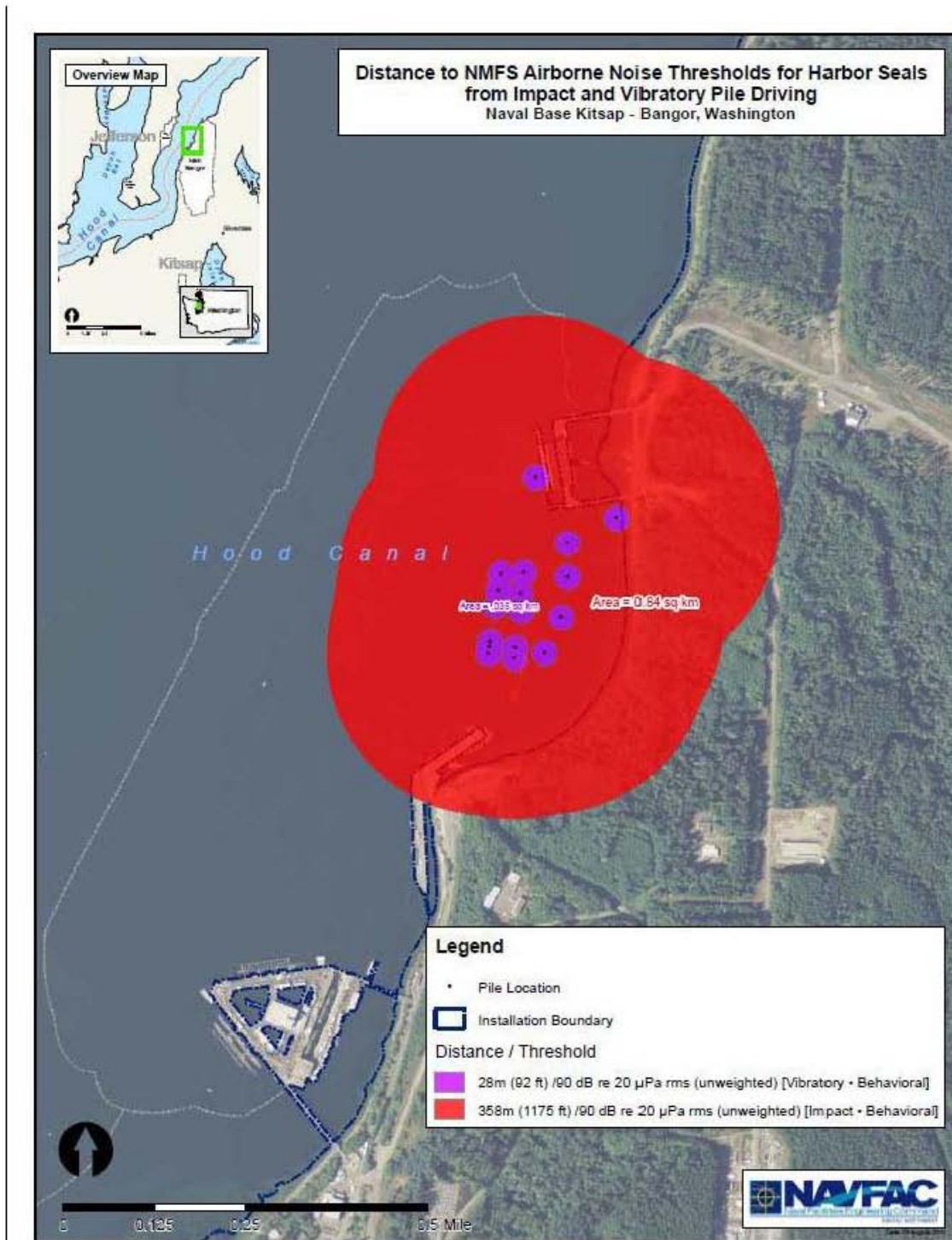


Figure 5. Distance to NMFS Airborne Noise Thresholds for Harbor Seals

U.S. Navy Test Pile Program in Hood Canal  
MARINE MAMMAL MONITORING PLAN  
May 2011

### 3.0 METHODOLOGY

#### 3.1 OBSERVER QUALIFICATIONS

All observers will be experienced biologists with training in marine mammal identification and behaviors. Trained observers have specific knowledge of marine mammal physiology, behavior, and life-history, which may improve their ability to detect individuals or help determine if observed animals are exhibiting behavioral reactions to construction activities. The observers will have no other construction related tasks while conducting monitoring.

#### 3.2 DATA COLLECTION

The marine mammal observers (MMOs) will use the NMFS-approved Marine Mammal Sighting Form (Appendix A) which will be completed by each observer for each survey day. The following information will be collected on the sighting form.

- Date and time that pile driving begins or ends;
- Construction activities occurring during each observation period;
- Weather parameters identified in the acoustic monitoring (e.g. wind, humidity, temperature);
- Tidal elevation and direction of change, sea state, and water currents: The Beaufort Sea State Scale (Appendix B) will be used to determine sea-state.
- Visibility
- Species, numbers, and if possible, sex and age class of marine mammals;
- Marine mammal behavior patterns observed, including bearing from observer and direction of travel. If possible, include the correlation to sound pressure levels for context;
- Distance from pile driving activities to marine mammals and distance from the marine mammal to the observation point;
- Locations of all marine mammal observations;
- Other human activity in the area.

#### 3.3 EQUIPMENT

The following equipment will be required to conduct marine mammal monitoring:

1. Survey boats (with depth finder/ measuring tape, range finder, navigational plotting equipment, and GPS Units)
2. Hearing protection for biologists in the airborne impact injury zone
3. Portable radios to communicate with the Pile Driving Engineer Lead and other observers
4. Cellular phones (one per boat and for each land observer) with contact information for the other observers (boats/land), Pile Driving Engineer Lead, and NMFS point of contact.
5. Green flags (one per boat/land observer) as back-up for radio communication
6. Red flags (one per boat/land observer) as back-up for radio communication
7. Nautical charts
8. Daily tide and current tables for the project area within the Hood Canal
9. Steel-cased thermometer or an equivalent electronic instrument (YSI) with underwater temperature probe



10. Watch or Chronometer
11. Binoculars with built-in rangefinder or reticles – (quality 7 x 50 or better)
12. Spotting scope for land observers
13. Monitoring plan and equipment list in sealed clear plastic cover
14. Notebook with pre-standardized monitoring Marine Mammal Observation Record forms on non-bleeding paper
15. Marine mammal visual keys encased in clear plastic
16. Large zip-lock bags
17. Clipboard / Tatum
18. Pen / Pencil

### 3.4 SHUTDOWN AND BUFFER ZONES

The acoustic modeling results presented within the Environmental Assessment, Biological Assessment, and the request for an Incidental Harassment Authorization were used to develop the shutdown and buffer zones for pile installation and removal activities associated with the Test Pile Program. While the acoustic zones of influence vary between the different diameter piles and types of installation and removal methodologies, the Navy established monitoring zones – shutdown and buffer zones - based on the maximum zone of influence for all pile installation and removal activities (see analysis in compliance documents for details). The monitoring zones were created to delineate areas that are important to species that are sensitive to the proposed action. Monitoring of these zones and implementing other minimization measures, such as the use of sound attenuation devices, will reduce the impacts of underwater sound from pile driving/removal on these species.

#### Shutdown Zone:

The shutdown zone shall include all areas where the underwater sound pressure levels (SPLs) are anticipated to equal or exceed the Level A (injury) Harassment criteria for marine mammals (180 dB isopleths for cetaceans; 190 dB isopleths for pinnipeds). For impact and vibratory pile installation and removal, monitoring will be conducted for a 50 meter\* shutdown zone (Level A harassment) surrounding each pile for the presence of marine mammals before, during, and after pile operations.

#### Buffer Zone:

The buffer zone shall include all areas where the underwater or airborne sound pressure levels are anticipated to equal or exceed the Level B (behavioral disturbance) Harassment criteria for marine mammals (160 dB re 1 $\mu$ Pa - impact hammer; 120 dB re 1 $\mu$ Pa - vibratory hammer; 90 or 100 dB re 20 $\mu$ Pa - airborne). For impact pile installation, monitoring will be conducted for a 464 meter buffer zone (Level B harassment) surrounding each pile for the presence of marine mammals before, during, and after impact pile driving activities. For vibratory pile installation and removal activities, the modeling predicts an affected area of 41.5 sq. km for the 120 dB RMS disturbance criterion. Due to the difficulty of effectively monitoring such a large area, the Navy intends to monitor a buffer zone equivalent to the width of the Hood Canal for the presence of marine mammals before, during, and after pile installation and removal activities. However, if

---

\* Based on coordination with NMFS HQ, a minimum shutdown zone of 50 meters was recommended to standardize monitoring activities at the NBK waterfront, even though this zone is slightly larger than the modeled Level A harassment zone. This measure will be implemented for impact and vibratory pile installation and removal activities. This mitigation only applies to marine mammals

the in-situ acoustic monitoring indicates that the 120 dB rms isopleth is smaller than the width of the Hood Canal, the monitoring zone would be reduced accordingly. Observers will still be placed at various locations throughout the 120 dB rms vibratory disturbance zone, as indicated in Figure 8, and sightings occurring in this area, including the general location of the animal, will still be recorded and noted as a take. However, detailed observations within this zone may not be possible. Due to the large area that each observer would be required to monitor, the distance between the observer and the animal may preclude the ability to determine fine-scale behavioral movements

To verify the required monitoring zones, the survey boats will be equipped with GPS units to ensure they travel out to the appropriate distances and maintain the integrity of the monitoring zones throughout the pile driving period. The buffer and shutdown zones will initially be based on the distances discussed previously. However, the Navy will also conduct in-situ acoustic monitoring to determine the actual distances to these threshold zones, and the size of the shutdown and buffer zones will be adjusted accordingly (increased or decreased) based on the received sound pressure levels. As these buffers are adjusted, the number of personnel and/or positioning of observers will also be adjusted accordingly. For instance, the Navy anticipates that the actual zone of influence for the 120 dB rms behavioral disturbance threshold is likely to be much smaller than was modeled. If in-situ recordings result in a substantial decrease in the area necessary to be surveyed for the 120 dB rms disturbance zone, one or more of the vessels in this area may be removed if unnecessary for effective monitoring of marine mammals. It is anticipated that two of the far-field monitoring vessels may not be needed on-site for the duration of the project.

### 3.5 OBSERVER MONITORING LOCATIONS

In order to effectively monitor the shutdown and buffer zones, marine mammal observers will be positioned at the best practicable vantage point(s), taking into consideration security, safety, and space limitations at the NBK waterfront, in order to properly monitor these zones. Security restrictions inside the water restricted area (WRA) have precluded the placement of boats/personnel at certain locations within the port security barrier (PSB) fence line. For instance, security concerns regarding the number of vessels within the WRA have resulted in the Navy limiting the number of monitoring vessels for the acoustic, marine mammal, and marbled murrelet monitoring plans to three boats, in addition to the construction related vessels (i.e. barges, tugs, etc.). Additionally, security requires that all vessels maintain a minimum standoff distance of 25 feet from the PSB fence at all times. Due to ongoing operations that may occur at the EHW-1 facility and Marginal Wharf, monitoring personnel are also precluded from being stationed on these structures. Lastly, marine mammal observers were not placed on the barge(s) due to safety concerns from the construction contractor.

The following near-field locations (depicted in Figure 6) have been identified to provide adequate visual coverage:

#### Near-field Boat Locations:

- **North Monitoring Boat:** Small boat vantage point located within the Water Restricted Area (WRA) that will survey the injury zone and impact behavioral disturbance zone to the north of each pile location. This boat will accommodate both marine mammal and

marbled murrelet observers. During impact pile driving the boat will undertake a circular transect pattern to aid in marbled murrelet monitoring. At all other times it can either use a transect search pattern or be stationary and positioned at a location to provide the best vantage point,

- **South Monitoring Boat:** Small boat vantage point located within the Water Restricted Area (WRA) that will survey the injury zone and impact behavioral disturbance zone to the south of each pile location. This boat will accommodate both marine mammal and marbled murrelet observers. During impact pile driving the boat will undertake a circular transect pattern to aid in marbled murrelet monitoring. At all other times it can either use a transect search pattern or be stationary and positioned at a location to provide the best vantage point,
- **West Monitoring Boat:** Small boat vantage point located within the Water Restricted Area (WRA) that will survey the injury and impact behavioral disturbance zone to the west of each pile location. This boat will be used for acoustic monitoring and will also accommodate marine mammal observers.
- 

Figure 6 depicts the relationship of the near-field monitoring positions to the acoustic zones of influence around an individual pile at the Test Pile Project site. Figure 7 depicts the survey pattern the North and South monitoring boats will undertake during impact pile driving operations to aid in marbled murrelet monitoring. Each near-field monitoring location will have a minimum of 1 dedicated marine mammal observer (not including boat operators). The exact positioning of the monitoring boats will vary as different pile locations are driven within the footprint of the proposed EHW-2 facility as part of the Test Pile Program. These monitoring vessels will also be used for marine mammal monitoring during concurrent pile driving that may also occur at the EHW-1 wharf under the EHW-1 Pile Replacement Project. As a result, the location of vessels will be positioned to provide adequate coverage for both projects. The positions pictured in Figure 6 are considered to be generally representative of the locations that will be used to accommodate monitoring for both projects.

As part of the Navy's Acoustic Monitoring Plan, additional boats with hydrophones are being positioned throughout the action area. These additional vessels will be used to obtain underwater sound pressure levels to accurately determine the sound propagation parameters present at the Test Pile Program project area. Marine mammal observers will be placed on these vessels in order to provide additional visual coverage throughout the modeled behavioral disturbance zone for vibratory pile installation/removal. These far-field observation locations will enable the Navy to track marine mammals as they ingress/egress the northern portion of the action area near Squamish Harbor and ingress/egress the action area south of the Base (e.g. Hazel Point). The following far-field locations (depicted in Figure 8) have been identified:

#### Far-field Locations:

- North Far-Field Location: Small boat vantage point located towards Squamish Harbor.
- Mid-Channel Boat Location: Small boat vantage point located in the middle of the Hood Canal directly west of the Test Pile Program location.
- South Far-Field Boat Location: Small boat vantage point located towards Hazel Point.

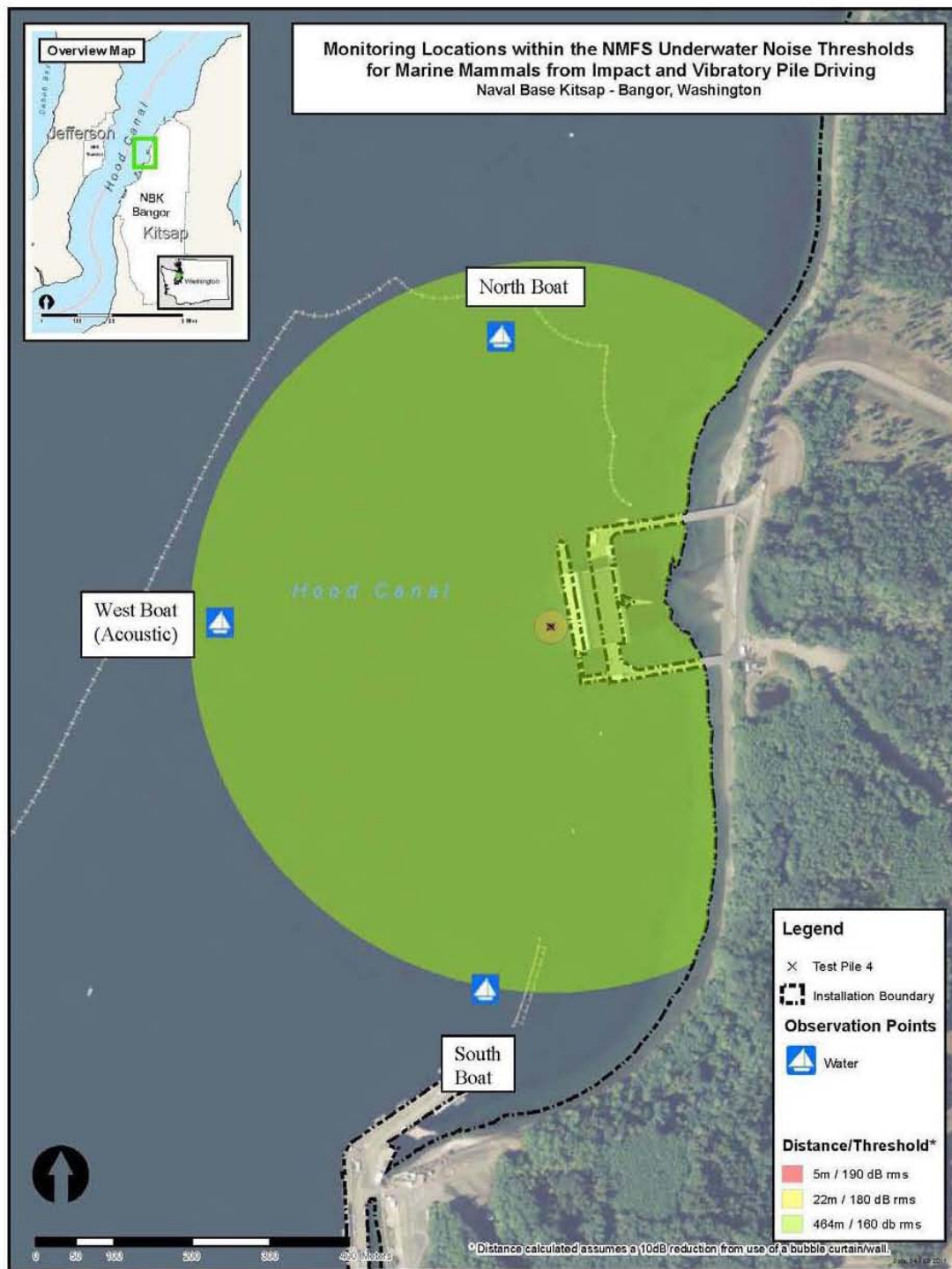


Figure 6. Near-Field Monitoring Locations within the NMFS Underwater Noise Thresholds for Marine Mammals from Impact and Vibratory Pile Installation/ Removal Activities

*U.S. Navy Test Pile Program in Hood Canal*  
MARINE MAMMAL MONITORING PLAN  
May 2011



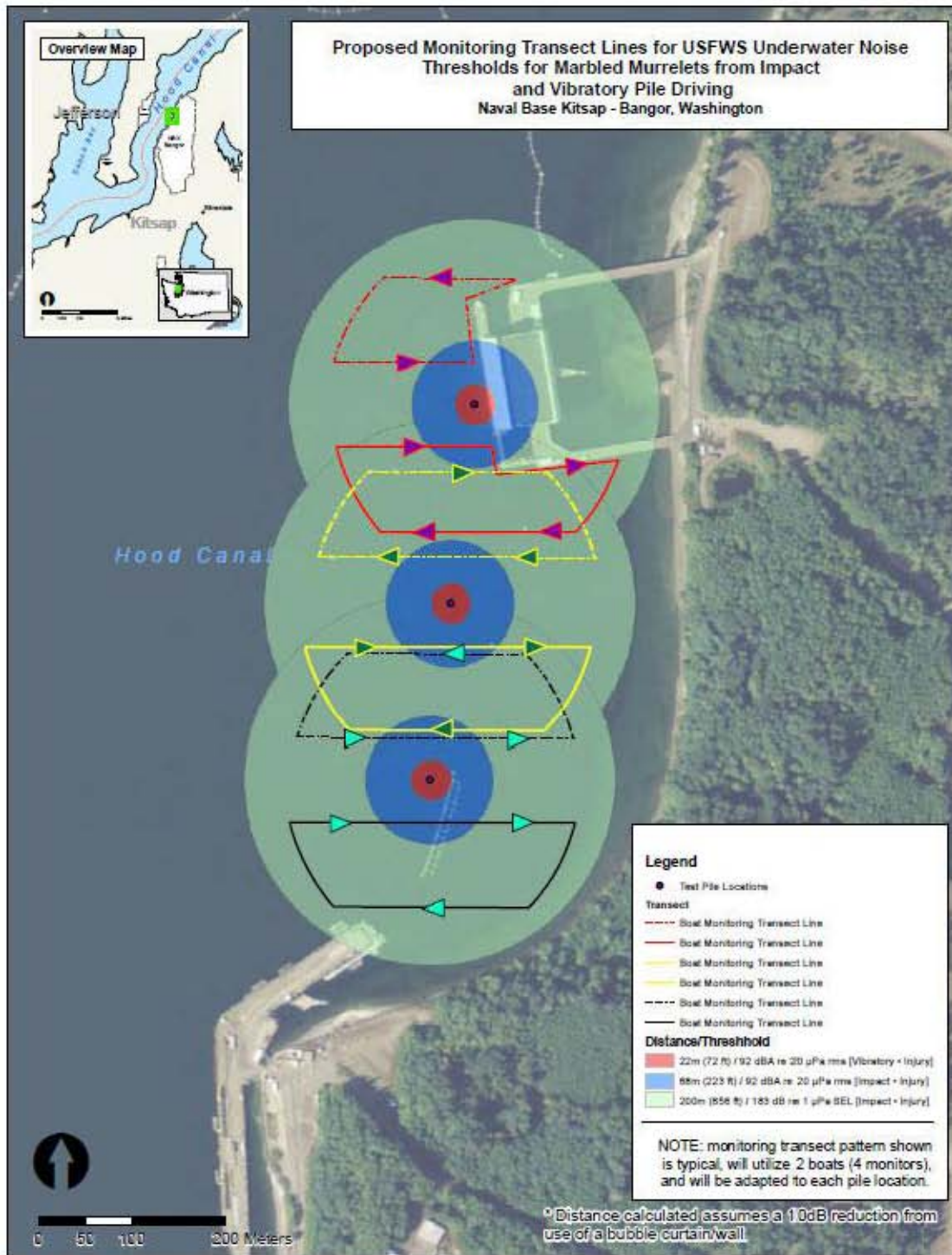


Figure 7. Survey Tracklines of the North and South Monitoring Vessels Depicted for Several Pile Locations During Impact Pile Driving for Marbled Murrelet Monitoring

U.S. Navy Test Pile Program in Hood Canal  
MARINE MAMMAL MONITORING PLAN  
May 2011



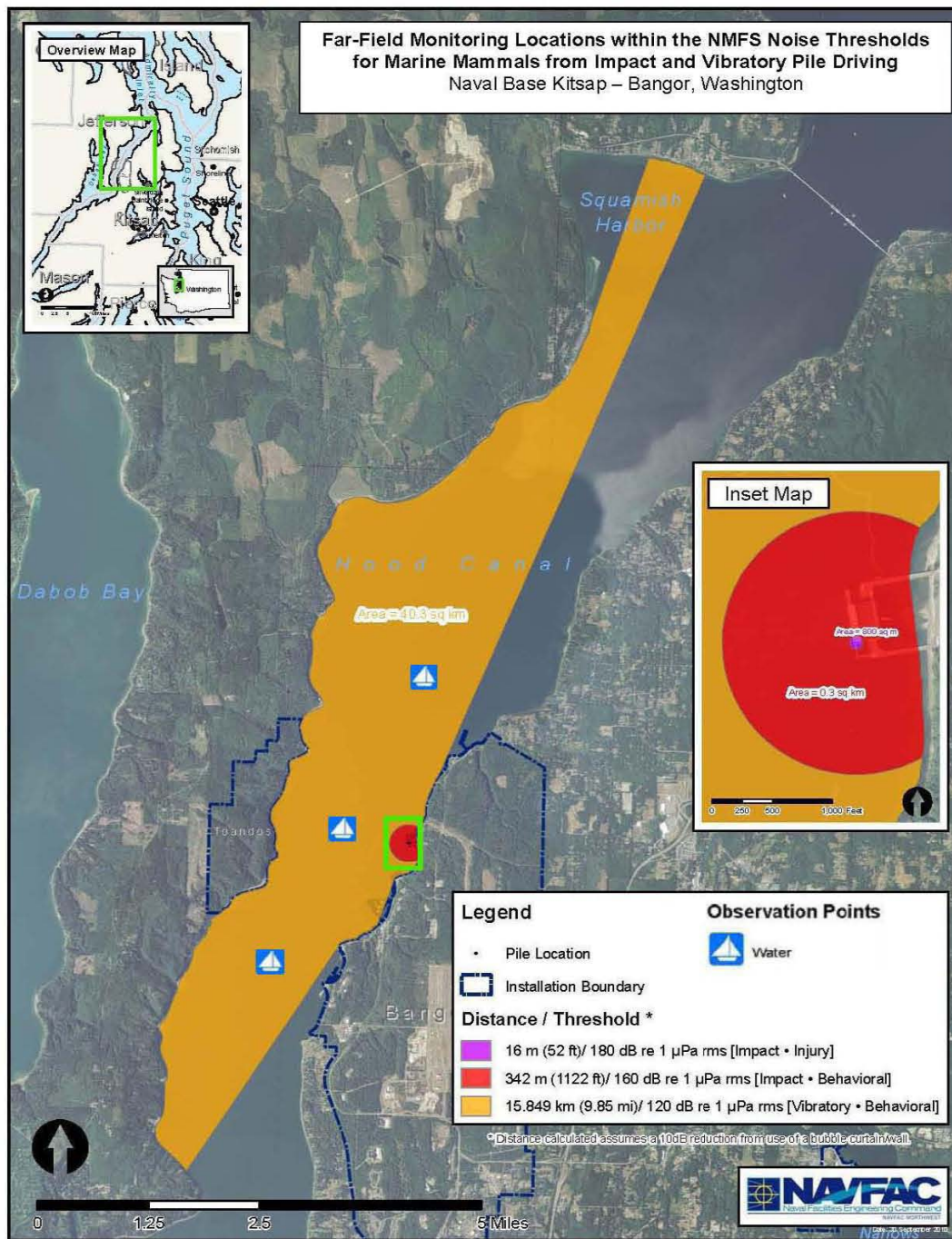


Figure 8. Far-Field Marine Mammal Monitoring Locations within the NMFS Noise Thresholds for Impact and Vibratory Pile Installation Activities

U.S. Navy Test Pile Program in Hood Canal  
MARINE MAMMAL MONITORING PLAN  
May 2011

Each far-field monitoring boat will have a minimum of 1 marine mammal observer not including boat operators or hydroacoustic monitoring staff. In-situ acoustic monitoring will be used to determine the actual extent of the 120 dB rms behavioral disturbance zone. If the acoustic recordings indicate that the actual zone of influence is significantly smaller than the modeled area, some of the far-field monitoring locations will be removed or consolidated if they are unnecessary for effective marine mammal monitoring. It is anticipated that two of the far-field monitoring vessels may not be needed on-site for the duration of the project.

### 3.6 MONITORING TECHNIQUES

It should be recognized that although marine mammals will be protected from Level A (injury) Harassment by the utilization of a sound attenuation devices and observers monitoring the near-field injury zones, mitigation may not be one hundred percent effective at all times in locating marine mammals within the buffer zone (Level B [behavioral] harassment zone). This is largely due to the size of the buffer zone area. However, the efficacy of visual detection depends on several factors including the observer's ability to detect the animal, the environmental conditions (visibility and sea state), and monitoring platforms. Monitoring of the shutdown and buffer zones will take place from 30 minutes prior to initiation through 30 minutes post-completion of all pile installation and removal activities.

#### 3.6.1 Visual Survey Protocol – Pre-Activity Monitoring

Prior to the start of pile operations, the shutdown and buffer zones will be monitored for 30 minutes to ensure that there are no marine mammals present. The following survey methodology will be implemented prior to commencing pile installation/removal activities:

- Near-field observers will survey the shutdown zone and buffer zones. They will ensure that no marine mammals are seen within the shutdown zone before pile-driving begins;
- If marine mammal(s) are present within or approaching the shutdown zone prior to pile driving, or during the soft-start<sup>1</sup>, the survey will continue and the start of pile driving will be delayed until the animal(s) leave the shutdown zone voluntarily.
- If marine mammals are not within the shutdown zone (i.e. the zone is deemed clear of marine mammals), the observers will raise a green flag and radio the Pile Driving Engineer Lead that pile driving can commence;
- The survey boats within the vibratory behavioral zone, stationed to the north and south of the WRA, as indicated in Figure 8, will look for the presence of marine mammals and will radio to near-field observers if marine mammals are traveling toward the buffer/shutdown zones.
- Marine Mammal Observation Record forms (Appendix A) will be used to document observations.

---

<sup>1</sup> The Test Pile Program will utilize soft-start techniques recommended by NMFS for impact and vibratory pile driving. For a vibratory hammer, the soft start requires the contractor to initiate noise from the vibratory hammer for 15 seconds at reduced energy followed by a 1-minute waiting period. This procedure should be repeated two additional times. For an impact hammer, contractors are required to provide an initial set of three strikes from the impact hammer at approximately 40 percent energy followed by a 1-minute waiting period, then two subsequent 3-strike sets.

### 3.6.2 Visual Survey Protocol – During Activity Monitoring

The shutdown and buffer zones will be monitored throughout the time required to install or remove a pile. The following survey methodology will be implemented during pile operations:

- If a marine mammal is observed entering the buffer zone (or larger vibratory behavioral disturbance zone), a “take” would be recorded and behaviors documented. However, that pile segment would be completed without cessation, unless the animal enters or approaches the shutdown (injury) zone, at which point all pile installation/removal activities will be halted. The observers shall immediately radio to alert the Pile Driving Lead Engineer and raise a red flag. This action will require an immediate “all-stop” on pile operations.
- Pile installation/removal activities will be delayed until the animal has voluntarily left the shutdown zone and has been visually confirmed beyond the shutdown zone, or 30 minutes have passed without re-detection of the animal.
- During the pile driving delay, surveys will continue to be conducted and pile driving will not resume until the shutdown zone has been deemed clear of all marine mammals (see Section 3.6.1 regarding procedures for proceeding with pile driving);
- If marine mammals are detected outside the shutdown zone, the observers will continue to monitor these individuals and record their behavior, but pile driving may proceed. Any marine mammals detected outside the shutdown zone after pile driving is initiated shall likewise continue to be monitored and their behaviors recorded;
- Marine Mammal Observation Record forms (Appendix A) will be used to document observations.
- Any survey boats engaged in marine mammal monitoring will maintain speeds equal to or less than 10 knots;
- Observers will be trained and experienced marine mammal observers in order to accurately verify species sighted;
- Observers will use binoculars and the naked eye to search continuously for marine mammals;
- In case of fog or reduced visibility, the observers must be able to see the shutdown and buffer zones or pile driving will not be initiated until visibility in these zones improves to acceptable levels;
- The above described monitoring efforts will be run concurrently with the marbled murrelet monitoring protocols.

### 3.6.3 Visual Survey Protocol – Post-Activity Monitoring

Monitoring of the shutdown and buffer zones will continue for 30 minutes following completion of pile installation and/or removal activities. These surveys will focus on observing and reporting unusual or abnormal behavior of marine mammals. In general, the same protocols described in section 3.6.2 would apply. During these surveys, if any injured, sick, or dead marine mammals are observed procedures outlined in Section 4.0 should be following regarding notifying the appropriate authorities. Survey results will be noted in the Marine Mammal Sighting form in Appendix A.

### 3.6.4 Acoustic Measurements

The Navy will conduct acoustic monitoring for impact and vibratory installation and removal activities associated with the Test Pile Program in order to determine the actual distances to the underwater and airborne thresholds for marine mammals and pinnipeds. These include the 190 dB re 1 $\mu$ Pa rms/180 dB re 1 $\mu$ Pa rms/160 dB re 1 $\mu$ Pa rms and 120 dB re 1 $\mu$ Pa rms underwater isopleths, and the 100 dB re 20  $\mu$ Pa and 90 dB re 20  $\mu$ Pa unweighted airborne isopleths. The Navy may place additional hydrophones/microphones at other distances and depths as appropriate to accurately capture sound propagation characteristics at the Test Pile project area. The Navy will also use hydroacoustic monitoring to determine the relative effectiveness of underwater sound attenuation devices (e.g. Gunderboom SAS<sup>TM</sup>, temporary noise attenuation piles [TNAPs], confined or unconfined bubble curtain) used during the Test Pile Program. Ambient underwater and airborne conditions in the absence of construction activities will also be recorded for comparison. The Navy's Acoustic Monitoring Plan provides the specific details of the acoustic monitoring requirements and protocol for both underwater and airborne sounds from the Test Pile Program.

## 4.0 INTERAGENCY NOTIFICATION

If the Navy finds an injured, sick, or dead marine mammal, the Navy shall notify NMFS immediately. Notification should be made to Brent Norberg (NMFS NW) at (206) 526-6140 and Ben Laws (NMFS HQ) (301) 713-2289 x159. The Navy will provide NMFS with the species or description of the animal(s), the condition of the animal (including carcass condition if the animal is dead), location, the date and time of first discovery, observed behaviors (if alive), and photo or video (if available).

Care should be taken in handling dead specimens to preserve biological materials in the best possible state for later analysis of cause of death, if that occurs. In preservation of biological materials from a dead animal, the finder (i.e. marine mammal observer) has the responsibility to ensure that evidence associated with the specimen is not unnecessarily disturbed.

## 5.0 MONITORING REPORT

A draft report will be submitted to NMFS within 45 days of the completion of the marine mammal monitoring associated with the Test Pile Program. The report will summarize all of the marine mammal observations and data gathered during pile installation and removal activities. The results should include graphs, tables, figures, and summary statistics as necessary. A final report will be prepared and submitted to the NMFS within 30 days following receipt of comments on the draft report from the NMFS. The report shall include at a minimum:

- General data:
  - Date and time of activity
  - Water conditions (e.g., sea-state, surface water temperature)
  - Weather conditions (e.g., wind speed and direction, air temperature, humidity)
  - Physical characteristics of the bottom substrate into which the piles are driven
- Specific pile driving data:
  - Description of the pile driving activity being conducted (pile size and type)



- Detailed description of the sound attenuation system, including design specifications
- Impact or vibratory hammer force used to drive/extract the piles
- Description of the monitoring equipment
- Distance between hydrophone(s) and pile
- Depth of the hydrophone(s)
- Depth of water in which the pile was driven
- Depth into the substrate that the pile was driven
- Ranges and means for peak, RMS, and SEL's for each pile
- Results of the acoustic measurements, including the frequency spectrum, peak and RMS SPL's, and single-strike and cumulative SEL with and without the attenuation system
- Results of the airborne noise measurements including dBA and unweighted levels;
- Pre-activity observational survey-specific data:
  - Dates and time survey is initiated and terminated
  - Description of any observable marine mammals and their behavior in the immediate area during monitoring
  - If possible, the correlation to underwater sound levels occurring at the time of this observable behavior for context to exposure.
  - Actions performed to minimize impacts to marine mammals
- Post-activity observational survey-specific data:
  - Results, which include the detectability of marine mammals, species and numbers observed, sighting rates and distances, behavioral reactions within and outside the shutdown and buffer zones;
  - Refined take estimate based on the number of marine mammals observed in the safety and buffer zones. This may be reported as one or both of the following: a rate of take (number of marine mammals per hour), or take based on density (number of individuals within the area).



~~APPENDIX A~~

MARINE MAMMAL SIGHTING FORM

*U.S. Navy Test Pile Program in Hood Canal*  
MARINE MAMMAL MONITORING PLAN  
May 2011

~~APPENDIX A~~  
MARINE MAMMAL SIGHTING FORM

Marine Mammal Observation Record Form							Observer	Date
Transect:		Time Survey Initiated:					Page _____ of _____ Pages	
		Time Survey Completed:						
		Type of Activity (Vibratory or Impact Pile driving):						
		Time of Specific Activity:						
Distance from Pile driving	Time	Weather Condition	Beaufort	Species	Number	Behavior	Notes	
<b>Weather:</b> S=Sunny, PC=Partly Cloudy, L=Light Rain, R=Steady Rain, F=Fog, OC=Overcast								
<b>Marine Mammal Behavior:</b> S=Swimming, D=Forage Dive, D=Disorientation, M=Mortality, N=No Response, H=Head Alert, F=Flush (from haul-out), A=Approach water (from haul-out), T=Traveling in a straight line; NT=Not traveling; MD=Moving in multiple directions; SS=Slow surfacing; O=Other (describe)								



U.S. Navy Test Pile Program in Hood Canal  
MARINE MAMMAL MONITORING PLAN  
May 2010

~~**APPENDIX B**~~



BEAUFORT SEA STATE SCALE

*U.S. Navy Test Pile Program in Hood Canal*  
MARINE MAMMAL MONITORING PLAN  
May 2010

**US Navy and Beaufort Sea State Codes** (<http://ioc.unesco.org> and <http://www.wrh.noaa.gov/pqr/info/beaufort.php>)



Beaufort SS	Wind speed (knots)	Wind description	Wave height (ft) Beaufort	Sea State – Beaufort	Notes specific to on-water seabird observations	Photos indicating Beaufort Sea State
0	<1	Calm	0	Calm; like a mirror	Excellent conditions, no wind, small or very smooth swell. You have the impression you could see anything.	 Force 0
1	1-3	Light air	¼ < ½	Ripples with appearance of scales; no foam crests	Very good conditions, surface could be glassy (Beaufort 0), but with some lumpy swell or reflection from forests, glare, etc.	 Force 1

U.S. Navy Test Pile Program in Hood Canal  
 MARINE MAMMAL MONITORING PLAN  
 May 2010

Beaufort SS	Wind speed (knots)	Wind description	Wave height (ft) Beaufort	Sea State – Beaufort	Notes specific to on-water seabird observations	Photos indicating Beaufort Sea State
2	4-6	Light breeze	½ – 1 (max 1)	Small wavelets; crests with glassy appearance, not breaking	Good conditions, no whitecaps; texture/lighting contrast of water make murrelets hard to see. Surface could also be glassy or have small ripples, but with a short, lumpy swell, thick fog, etc.	
3	7-10	Gentle breeze	2 – 3 (max 3)	Large wavelets; crests begin to break; scattered whitecaps	Fair conditions, scattered whitecaps, detection of murrelets definitely compromised; a hit-or-miss chance of seeing them owing to water choppiness and high contrast. This could also occur at lesser wind with a very short wavelength, choppy swell.  <b>Poor conditions, end surveys.</b>	

U.S. Navy Test Pile Program in Hood Canal  
 MARINE MAMMAL MONITORING PLAN  
 May 2010



Beaufort SS	Wind speed (knots)	Wind description	Wave height (ft) Beaufort	Sea State – Beaufort	Notes specific to on-water seabird observations	Photos indicating Beaufort Sea State
4	11-16	Moderate breeze	3 ½ – 5 (max 5)	Small waves becoming longer, numerous whitecaps	Whitecaps abundant, sea chop bouncing the boat around, etc.	 A photograph showing a choppy sea surface with numerous small whitecaps. The water is a dark greenish-brown color. The text 'Force 4' is written vertically on the left side of the image.
5	17-20	Fresh breeze	6 – 8 (max 8)	Moderate waves, taking longer form; many whitecaps; some spray		 A photograph showing a more turbulent sea surface with larger, more defined waves and many whitecaps. The water is a deep blue color. The text 'Force 5' is written vertically on the left side of the image.

U.S. Navy Test Pile Program in Hood Canal  
 MARINE MAMMAL MONITORING PLAN  
 May 2010

## APPENDIX B

### Baseline Survey Data

#### Hood Canal Surveys

The Hood Canal survey transects followed a zigzag (**Figure B-1**) from the southern tip of the Toandos Peninsula to, generally, the NOAA buoy to the north of the WRA. However, some surveys also traveled north to the area at the mouth of Thorndike Bay as well as above the Hood Canal floating bridge. **Figure B-1** shows all of the available tracklines along with a 1,640 ft (500 m) buffer on either side of the trackline to identify area covered. For the survey days from August 25<sup>th</sup> to September 12<sup>th</sup> (five survey days), boats were semi-stationary and did not follow specific tracklines. On these days boats stationed themselves at the northern, mid- and southern parts of the channel and stayed in the same general area throughout the day. Unfortunately, tracklines were not downloaded on those five days due to GPS error. For surveys days from the September 13<sup>th</sup> to October 26<sup>th</sup> (ten survey days), 22 points approximately 0.5 nm (1 km) apart were provided to the MMOs and boat captains as a basis for the criss-cross pattern. (The shoreline transects on 10/21 and 10/22 were marbled murrelet transects, but because there was a marine mammal observer onboard, ancillary marine mammal data was collected and included in **Figure B-1**.) Daily tracklines were downloaded and archived. Each day was begun at a different point and ended at a different to eliminate covering the same area at the same time of day.

The area covered from August 25<sup>th</sup> to September 12<sup>th</sup> is based on the northern- and southern-most sightings locations as well as the eastern and western shorelines of the Hood Canal (**Table B-1**). The area covered from September 13<sup>th</sup> to October 26<sup>th</sup> is based on the 1,640 ft (500 m) buffer on either side of the trackline for that day (see **Figure B-1**). A total of 443.5 km<sup>2</sup> (129.3 nm<sup>2</sup>) were covered during 60:13 hours of surveys. The total trackline length was 471.3 km (254.5 nm).

A total of 266 sightings occurred during all survey days (**Table B-2**) with the most commonly seen species being the harbor seal (n=197, 74 percent), followed by the harbor porpoise (n=34, 13 percent) and the California sea lion (n=33, 12 percent). However, throughout the Hood Canal, the California sea lion had the highest number of individuals seen per sighting (**Figure B-2**) at 7.1, followed by the northern river otter (5.0), the harbor porpoise (2.6), the harbor seal (1.4), and the Steller sea lion (1.0). There was one sighting of the northern river otter with five individuals, so the number of individuals seen per sighting in the Hood Canal may be skewed somewhat based on this one sighting. **Table B-3** provides a list of all sightings and **Figures B-3 through B-6** show all of the sightings occurring from August 25<sup>th</sup> to October 26<sup>th</sup>.

**Figures B-7 and B-8** show that the most common behavior observed was looking (n=95, 22.5 percent) followed by sinking (n=86, 20.4 percent), swimming (n=74, 17.5 percent), and diving (n=56, 13.3 percent). The numbers of all other behaviors ranged from 1 to 36 instances (0.2 percent to 8.5 percent). Based on the more detailed notes associated with the sightings, there were two sightings (0.8 percent) in which the MMOs' noted behavior that could be construed as reacting to the boat. These sightings were both of single harbor seals and the behaviors included a startle reaction to the boat and then a dive, and in the second sighting a look and sink series of behaviors. In both cases the animals were not observed again within the same vicinity as they were initially sighted.

## Dabob Bay Surveys

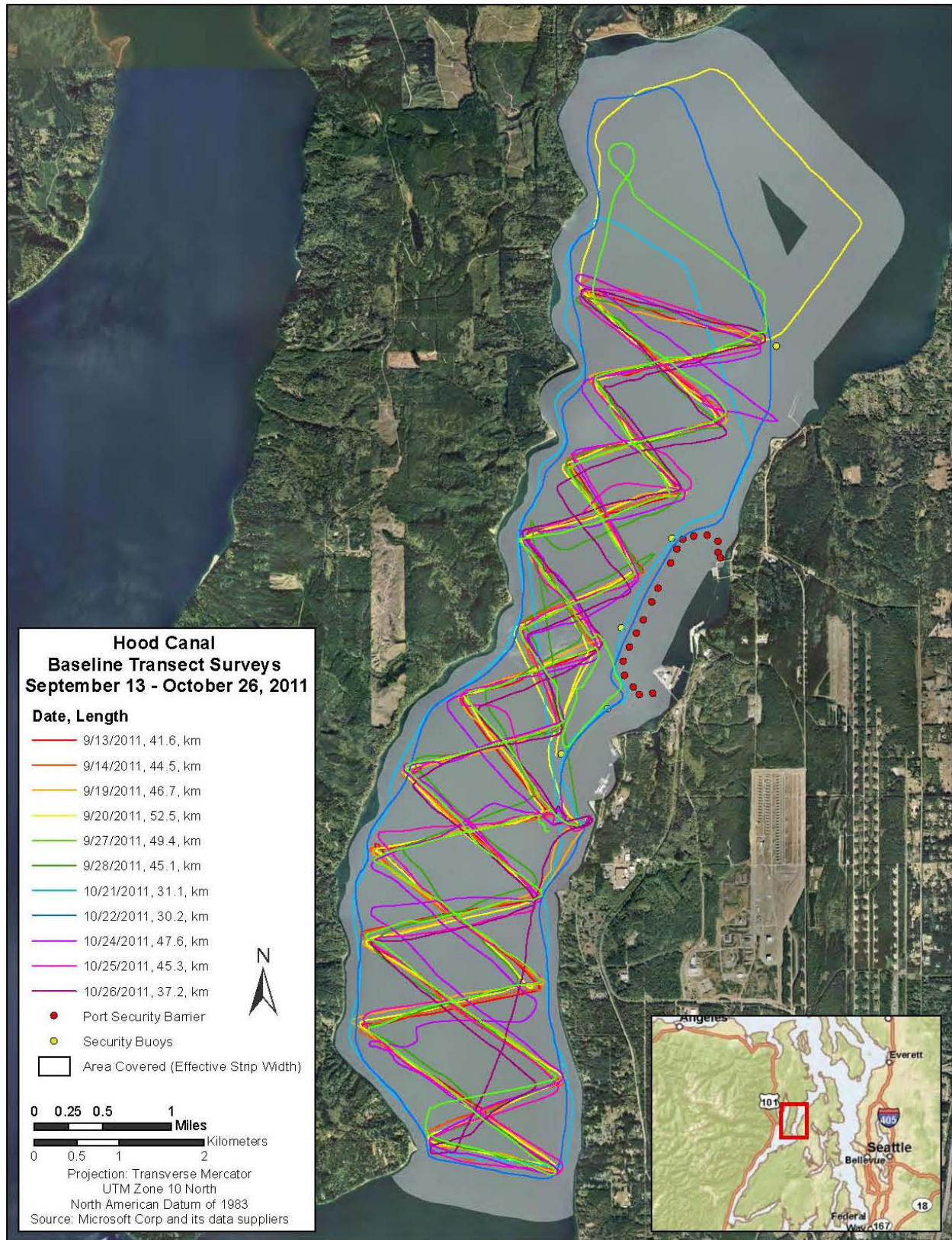
The Dabob Bay survey transects generally followed the shoreline contours of Dabob Bay (**Figure B-9**) from the southern tip of the Toandos Peninsula to the northern region of Dabob Bay. A large exclusion zone surrounding a Navy ship moored semi-permanently in Dabob Bay made it difficult to perform zig-zag transects across the bay; therefore, early attempts at surveys in Dabob did not follow a zig-zag pattern, and switching to this survey pattern later in the project would have made density information collected during early “loop pattern” surveys incompatible with later data. These surveys had a dual purpose of collecting marine mammal and marbled murrelet data, and shoreline surveys tended to yield more marbled murrelet sightings (Hart Crowser, 2012). Therefore, this loop pattern was followed during all subsequent baseline surveys in the bay. However, on some days, transects moved further off shore to provide coverage for the mid-Bay. **Figure B-9** shows all of the daily tracklines along with a 1,640 ft (500 m) buffer on either side of the trackline to identify area covered. Survey transects were run from the September 12<sup>th</sup> to October 26<sup>th</sup> (eleven survey days). Because it took approximately 1 hour to travel the southern tip of the Toandos Peninsula, this was the starting and stopping point for each survey. However, the surveys did not necessarily cover the exact same transect from day to day, so that a large area of the bay could be covered. During part of the survey time period, a U.S. Navy research barge was stationed at the northern extent of Dabob Bay. Survey boats were requested to maintain a standoff distance at least 1,640 ft (500 m) from buoys surrounding the barge. As a result, this area was not surveyed completely.

The area covered in **Table B-4** is based on the 1,640 ft (500 m) buffer on either side of the trackline for that day (see **Figure B-9**). A total of 91.8 nm<sup>2</sup> (315 km<sup>2</sup>) were covered during 29:40 hours of surveys. The total trackline length was 211.7 nm (392.1 km). On October 26<sup>th</sup>, weather conditions precluded a survey into Dabob Bay. The survey vessel was able to round the tip of the Toandos Peninsula before the boat captain made the decision to turn back for safety reasons.

A total of 330 sightings occurred during all survey days (**Table B-5**) with the most commonly seen species being the harbor seal (n=302, 94 percent), followed by the harbor porpoise (n=12, 4 percent) and the California sea lion (n=5, 2 percent). However, throughout Dabob Bay, the harbor porpoise had the highest number of individuals seen per sighting (**Figure B-10**) at 2.5, followed by the harbor seal (1.5), and the California sea lion (1.4). A single sighting of an unknown pinniped was also noted. **Table B-6** provides a list of all sightings and **Figures B-11 through B-14** shows all of the sightings occurring from September 12 to October 26.

**Figures B-15 and B-16** show that the most common behavior observed was looking (n=115, 24.2 percent) followed by sinking (n=106, 22.3 percent), diving (n=80, 16.8 percent), swimming (n=79, 16.6 percent), and resting (n=70, 14.7 percent). The numbers of all other behaviors ranged from 1 to 19 instances (0.2 percent to 4.0 percent). Based on the more detailed notes associated with the sightings, there were two sightings (0.6 percent) in which the MMOs’ noted behavior that could be construed as reacting to the boat. One sighting was of eight harbor seals that all appeared simultaneously as the vessel followed its’ transect. This group of harbor seals looked, swam and then dove in the same general direction. The second sighting was of a single harbor seal that quickly looked and sank. This sighting was during a Beaufort 4 sea state, so this may have influenced the behavior somewhat. In both cases the animals were not observed again within the same vicinity as they were initially sighted.





**Figure B-1. All survey transects and 1,640 ft (500 m) strip width for Hood Canal**

**Table B-1. Summary of the Transect and Sightings Data for Hood Canal**

Date	Day Type	Area Covered (km <sup>2</sup> )*	Trackline Length (km)	Total Survey Time (hh:min)	Total Survey Time (hours)	Species	# of Sightings	# of Animals	Sighting Frequency (Individuals/km <sup>2</sup> /hour)
25-Aug-2011	Semi^ Stationary	3.3	N/A	06:50	6.833	CASL	4	7	0.177
						HSEA	12	18	0.532
26-Aug-2011	Semi^ Stationary	3.2	N/A	03:50	3.833	HSEA	8	10	0.652
						HPOR	1	4	0.082
3-Sep-2011	Semi^ Stationary	59.6	N/A	04:10	4.167	CASL	4	18	0.016
						HPOR	4	6	0.016
						HSEA	10	14	0.040
9-Sep-2011	Semi^ Stationary	90.7	N/A	04:55	4.917	CASL	1	13	0.002
						HPOR	12	31	0.027
						HSEA	27	48	0.061
						RIVO	1	5	0.002
12-Sep-2011	Semi^ Stationary	27.6	N/A	04:25	4.417	CASL	1	6	0.008
						HPOR	4	10	0.033
						HSEA	8	9	0.066
13-Sep-2011	Transect	25.0	41.6	03:12	3.200	CASL	1	1	0.013
						HPOR	1	3	0.013
						HSEA	13	14	0.163
14-Sep-2011	Transect	25.9	44.5	03:46	3.767	CASL	2	9	0.020
						HPOR	3	7	0.031
						HSEA	8	8	0.082
19-Sep-2011	Transect	25.7	46.7	03:39	3.650	CASL	1	6	0.011
						HSEA	74	101	0.789
20-Sep-2011	Transect	31.7	52.5	03:50	3.833	CASL	3	23	0.025
						HPOR	2	8	0.016
						HSEA	10	10	0.082
27-Sep-2011	Transect	29.1	49.4	03:52	3.867	CASL	1	27	0.009
						HPOR	1	6	0.009
						HSEA	6	6	0.053
28-Sep-2011	Transect	25.3	45.1	03:40	3.667	CASL	1	1	0.011
						HPOR	4	11	0.043
						HSEA	7	7	0.075



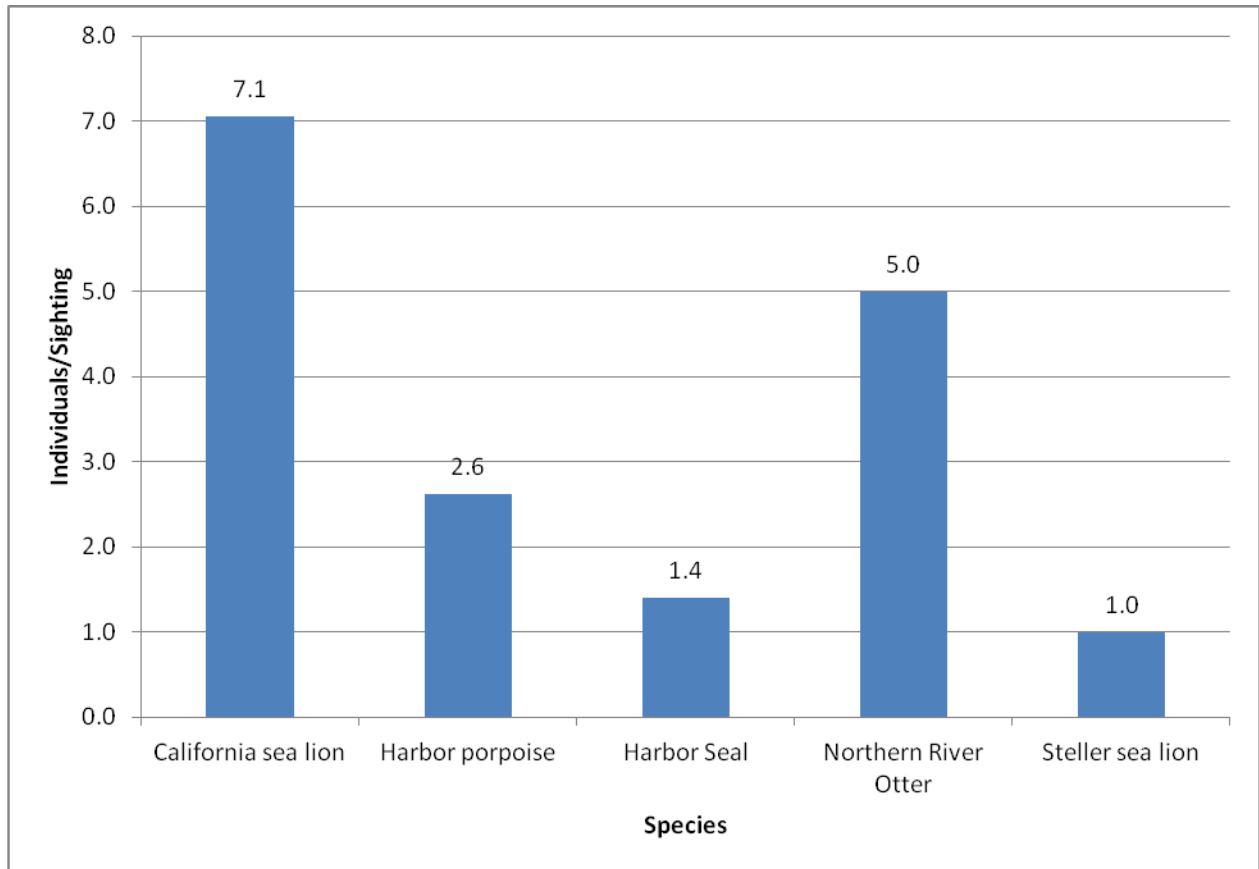
Date	Day Type	Area Covered (km2)*	Trackline Length (km)	Total Survey Time (hh:min)	Total Survey Time (hours)	Species	# of Sightings	# of Animals	Sighting Frequency (Individuals/km2/hour)
22-Oct-2011	Transect	23.6	30.2	02:07	2.917	CASL	5	30	0.073
						HPOR	1	1	0.015
						HSEA	3	5	0.044
21-Oct-2011	Transect	20.9	31.1	02:55	2.117	CASL	1	6	0.023
						HPOR	1	2	0.023
						HSEA	4	13	0.090
24-Oct-2011	Transect	26.3	47.6	03:30	3.500	CASL	3	24	0.033
						HSEA	3	11	0.033
25-Oct-2011	Transect	26.1	45.3	03:02	3.033	CASL	4	31	0.051
						HSEA	6	6	0.076
26-Oct-2011	Transect	23.1	37.2	02:30	2.500	CASL	1	31	0.017
						STSL	1	1	0.017

\* For the surveys from August 25<sup>th</sup> to September 12<sup>th</sup>, tracklines were not available. Area was calculated by using the northernmost and southernmost sightings as the northern and southern bounds and the eastern and western shorelines of the Hood Canal as the eastern and western bounds. All other areas are based on a 1,640 ft (500 m) buffer on either side of the trackline for that day

^ Data collected during semi-stationary surveys (August 25 through September 12) were not used to calculate animal density

**Table B-2. Total Number of Animals and Sightings During Hood Canal Baseline Surveys**

Species	# of Sightings	# of Animals
California sea lion	33	233
Harbor porpoise	34	89
Harbor seal	197	277
River Otter	1	5
Steller sea lion	1	1
<b>TOTAL</b>	<b>266</b>	<b>604</b>



**Figure B-2. Mean Number of Animals per Sighting (by Species) During Hood Canal Baseline Surveys**

Table B-3. All Sightings Data from Hood Canal

Date:	Time Observation Initiated:	Time Observation Completed:	Latitude	Longitude	Sighting Time	Species	# of Anim(s)	Dist./Dir. to Ani(s)	Behavior Type	Weather Conditions	Beaufort
25-Aug-11	09:20	16:10			09:57	HSEA	2		TR	S	0
25-Aug-11	09:20	16:10			10:07	HSEA	1			S	0
25-Aug-11	10:15	12:30			10:27	HSEA	2		TR	S	1
25-Aug-11	10:05		47 44.17	122 44.88	10:28	HSEA	1		TR,O	S	2
25-Aug-11			47 43.95	122 45.1	10:51	HSEA	1		TR,O	S	1
25-Aug-11	10:15	12:30			11:04	CASL	2		SI	S	1
25-Aug-11	10:15	12:30			11:10	HSEA	1		LO	S	1
25-Aug-11			47 44.36	122 44.62	11:13	HSEA	1		TR,O	S	1
25-Aug-11	10:15	12:30			11:18	HSEA	1		LO	S	1
25-Aug-11			47 44.33	122 44.63	11:29	CASL	3		LO,EW,LO	S	1
25-Aug-11			47 44.31	122 44.59	11:47	CASL	1		LO	S	1
25-Aug-11	09:20	16:10			12:03	HSEA	4		LO,SI	S	1
25-Aug-11	09:20	16:10			12:15	HSEA	1		SI,TR	S	1
25-Aug-11	09:20	16:10			12:18	HSEA	2		TR	S	1
25-Aug-11			47 44.33	122 44.72	12:25	CASL	1		LO	S	1
25-Aug-11	09:20	16:10			14:58	HSEA	1		DI	S	2
26-Aug-11	08:10	12:00	47 44.9	122 43.54	08:16	HSEA	1	75/W	LO,SI	S	0
26-Aug-11	08:10	12:00			08:18	HSEA	1		LO,SI	S	0
26-Aug-11			47 44.77	122 45.31	09:00	HPOR	4		TR	S	1
26-Aug-11	08:10	12:00	47 45.09	122 45.55	09:12	HSEA	1		TR	S	0
26-Aug-11	08:10	12:00	47 45.07	122 43.37	09:23	HSEA	1		TR,SI	S	0
26-Aug-11			47 45.165	122 43.516	09:25	HSEA	1		SI	S	0-1
26-Aug-11	08:29	09:48			09:31	HSEA	2		TR	S	1
26-Aug-11	08:29	09:48			09:31	HSEA	1		TR	S	1
26-Aug-11	08:29	09:48			09:40	HSEA	2		TR	S	1
3-Sep-11	08:50	13:00	47 44.799	122 44.273	09:03	CASL	8	10/E	RE	S	2
3-Sep-11	08:50	13:00	47 45.277	122 43.916	09:08	CASL	1	10/E	RE	S	2
3-Sep-11	09:03	13:00	47 44.48	122 44.3	09:14	CASL	8	125/350°-120°	RE	S	2
3-Sep-11	08:50	13:00	47 46.006	122 43.081	09:19	HSEA	1	100/N	LO,SI	S	2
3-Sep-11	08:50	13:00	47 46.006	122 43.081	09:20	HSEA	2	300/N	SW,DI	S	2
3-Sep-11	09:03	13:00	47 45.35	122 43.88	09:25	CASL	1	80/110°	RE	S	3
3-Sep-11	08:54	12:50	47 40.968	122 45.021	09:39	HSEA	2	50/s	LO,SI	s	2
3-Sep-11	09:03	13:00	47 46.1	122 42.85	09:44	HSEA	3	341/70°	LO,SI	S	3
3-Sep-11	09:03	13:00	47 46.69	122 41.73	10:03	HSEA	1	120/70°	LO,SI	S	3

Date:	Time Observation Initiated:	Time Observation Completed:	Latitude	Longitude	Sighting Time	Species	# of Anim(s)	Dist./Dir. to Ani(s)	Behavior Type	Weather Conditions	Beaufort
3-Sep-11	09:03	13:00	47 47.89	122 41.25	10:22	HSEA	1	80/345°	SW,LO,SI	S	3
3-Sep-11	08:50	13:00	47 50.868	122 40.817	10:36	HSEA	1	50/W	RE	S	2
3-Sep-11	08:54	12:50	47 42.862	122 45.763	11:32	HPOR	2	100/sw	TR,MI	s	3
3-Sep-11	08:50	13:00	47 45.712	122 45.144	11:45	HSEA	1	30/N	SW,DI	S	3
3-Sep-11	08:50	13:00	47 45.478	122 45.237	11:48	HSEA	1	53/N	SW,DI	S	3
3-Sep-11	08:54	12:50	47 41.786	122 45.304	11:52	HPOR	2	50/w	TR,CD	s	3
3-Sep-11	09:03	13:00	47 47.89	122 41.38	11:54	HPOR	1	150/240°	TR	S	3
3-Sep-11	08:54	12:50	47 41.878	122 46.285	12:00	HSEA	1	20/s	LO,SI,DI	s	3
3-Sep-11	08:54	12:50	47 42.328	122 46.007	12:12	HPOR	1	150/sse	TR	s	3
9-Sep-11	08:05	13:00	47 44.342	122 44.481	08:13	HSEA	1	50/68	SW	S	1
9-Sep-11	08:05	13:00	47 44.498	122 44.296	08:16	CASL	13	85/35	HO	S	1
9-Sep-11	08:07	12:15	47 43.439	122 45.732	08:20	HPOR	1	50/395	SW,MI	s	1
9-Sep-11	08:07	12:15	47 43.439	122 45.732	08:22	HSEA	2	100/325	LO,SI	s	1
9-Sep-11	08:17	12:00	47 45.953	122 44.928	08:33	HSEA	1	30/153	LO,SI	S	1
9-Sep-11	08:05	13:00	47 45.851	122 43.191	08:33	HSEA	1	150/12	SW,SI	S	1
9-Sep-11	08:05	13:00	47 46.132	122 42.885	08:37	HSEA	3	225/50	RE,LO,SI	S	1
9-Sep-11	08:17	12:00	47 46.5	122 44.685	08:40	HSEA	1	50/336	LO,SI	S	0-1
9-Sep-11	08:07	12:15	47 43.624	122 46.461	08:43	HSEA	1	95/350	LO,SW,DI,RE	s	1
9-Sep-11	08:05	13:00	47 46.382	122 42.682	08:43	HSEA	1	100/113	SW,DI	S	1
9-Sep-11	08:05	13:00	47 46.61	122 42.111	08:48	HSEA	2	130/30	LO,SI	S	1
9-Sep-11	08:07	12:15	47 43.296	122 46.747	08:49	HSEA	1	200/120	SW,LO	s	0
9-Sep-11	08:17	12:00	47 47.942	122 44.629	09:00	HPOR	5	100/9	PO	S	0-1
9-Sep-11	08:17	12:00	47 48.044	122 44.591	09:05	HSEA	1	300/53	LO,SI	S	0-1
9-Sep-11	08:05	13:00	47 49.717	122 40.211	09:16	HPOR	1	400/350	SW	S	1
9-Sep-11	08:07	12:15	47 41.473	122 46.175	09:22	HSEA	1	100/320	LO,SI,DI	s	1
9-Sep-11	08:05	13:00	47 49.097	122 39.174	09:24	HPOR	6	100/90	MI	S	2
9-Sep-11	08:07	12:15	47 41.274	122 46.446	09:28	HSEA	1	125/260	LO,SI	s	2
9-Sep-11	08:07	12:15	47 40.887	122 46.194	09:41	HPOR	1	20/330	SW,MI	s	2
9-Sep-11	08:17	12:00	47 47.708	122 42.84	09:43	HPOR	4	70/333	PO,TR(W)	S	2
9-Sep-11	08:07	12:15	47 40.296	122 45.842	09:47	HSEA	2	750/185	LO,DI	s	2
9-Sep-11	08:17	12:00	47 47.174	122 43.281	09:49	HPOR	1	65/33	PO,TR(E)	S	2
9-Sep-11	08:07	12:15	47 40.182	122 45.751	09:50	HSEA	1	150/180	LO	s	2
9-Sep-11	08:05	13:00	47 51.106	122 37.544	09:55	HSEA	1	400/200	LO,SI	S	2
9-Sep-11	08:17	12:00	47 46.44	122 43.791	09:56	HPOR	2	300/273	PO,TR(S)	S	2
9-Sep-11	08:17	12:00	47 46.44	122 43.791	09:57	HSEA	1	250/273	SW,SI	S	2
9-Sep-11	08:07	12:15	47 42.417	122 45.201	09:59	HSEA	2	200/40	LO,SI	s	2

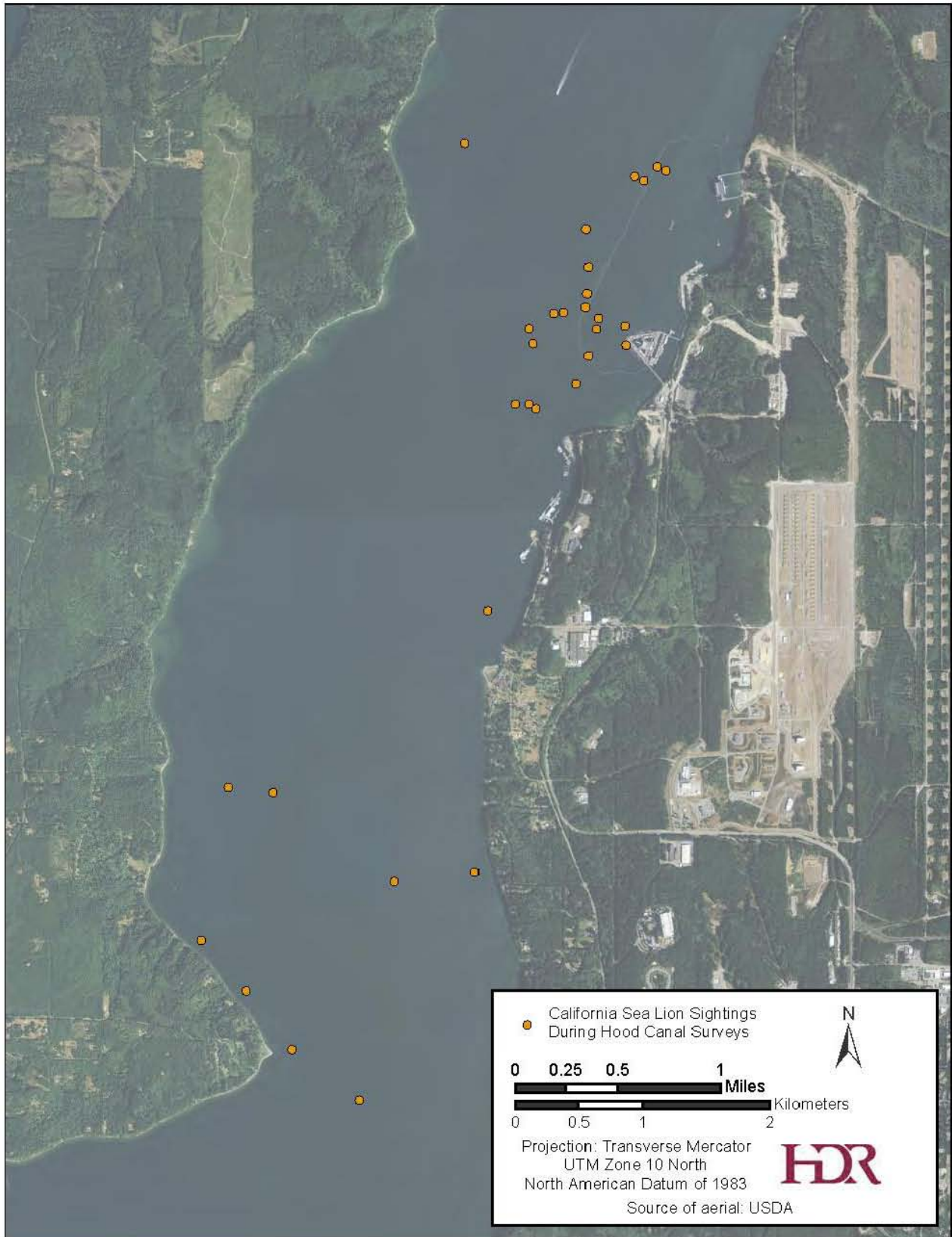
Date:	Time Observation Initiated:	Time Observation Completed:	Latitude	Longitude	Sighting Time	Species	# of Anim(s)	Dist./Dir. to Ani(s)	Behavior Type	Weather Conditions	Beaufort
9-Sep-11	08:05	13:00	47 51.08	122 38.06	09:59	HSEA	1	1000/310	HO	S	1
9-Sep-11	08:07	12:15	47 42.515	122 45.07	10:32	HSEA	1	700/60	LO,SI	s	2
9-Sep-11	08:07	12:15	47 42.624	122 45.076	10:33	HSEA	1	100/330	LO,SI	s	2
9-Sep-11	08:05	13:00	47 51.472	122 38.6	10:41	HSEA	16	75/8	HO,LO,FL	S	1
9-Sep-11	08:17	12:00	47 41.474	122 45.824	10:47	HPOR	1	85/221	PO,TR(N)	S	2
9-Sep-11	08:17	12:00	47 41.918	122 45.688	10:53	HSEA	1	300/112	LO,SW	S	2
9-Sep-11	08:07	12:15	47 43.372	122 45.536	10:55	HPOR	2	100/250	SW,MI	s	2
9-Sep-11	08:05	13:00	47 52.879	122 35.501	11:20	HPOR	6	50/128	SW,TR,DI	S	2
9-Sep-11	08:17	12:00	47 43.677	122 44.668	11:45	RIVO	5	8/310	LO,SW,DI,FO	S	1
9-Sep-11	08:05	13:00	47 50.926	122 37.418	11:47	HPOR	1	200/277	DI	S	1
9-Sep-11	08:17	12:00	47 43.677	122 44.668	11:48	HSEA	1	10/105	LO,SW,SI	S	1
9-Sep-11	08:05	13:00	47 50.76	122 37.782	11:50	HSEA	1	40/215	LO,DI	S	1
9-Sep-11	08:05	13:00	47 50.45	122 36.325	11:53	HSEA	2	150/320	TR	S	1
12-Sep-11	08:20	12:45	47 43.518	122 45.918	08:28	HSEA	2	25/127	LO,SI	OC	1
12-Sep-11	08:20	12:45	47 42.248	122 46.487	08:54	HSEA	1	150/150	LO,SI	OC	1
12-Sep-11	08:20	12:45	47 42.248	122 46.487	08:56	HPOR	1	250/128	SW	OC	1
12-Sep-11	08:20	12:45	47 42.265	122 45.561	09:00	HSEA	1	185/122	LO,DI	OC	1
12-Sep-11	08:20	12:45	47 42.119	122 45.395	09:05	HPOR	6	80/171	TR	OC	1
12-Sep-11	08:20	12:45	47 45.13	122 44.431	09:58	CASL	6	1005/150	HO	OC	2
12-Sep-11	08:20	12:45	47 45.13	122 44.431	09:58	HPOR	1	210/120	MI	OC	2
12-Sep-11	08:20	12:45	47 45.877	122 44.443	10:05	HPOR	2	55/330	TR	OC	2
12-Sep-11	08:20	12:45	47 46.843	122 43.467	10:27	HSEA	1	75/270	LO,SI	OC	2
12-Sep-11	08:20	12:45	47 46.893	122 43.688	10:29	HSEA	1	75/330	LO,SI	OC	2
12-Sep-11	08:20	12:45	47 47.093	122 44.165	10:32	HSEA	1	150/263	LO,SI	OC	2
12-Sep-11	08:20	12:45	47 45.557	122 44.779	10:58	HSEA	1	38/330	LO,SI	OC	2
12-Sep-11	08:20	12:45	47 44.348	122 45.58	11:18	HSEA	1	70/140	LO,SI	OC	2
13-Sep-11	09:11	12:23	47 44.11	122 45.1	09:19	HSEA	1	60/354	LO,DI	F,L,OC	0
13-Sep-11	09:11	12:23	47 42.449	122 45.793	09:24	HSEA	1	210/10	LO,SI	F,L,OC	0
13-Sep-11	09:11	12:23	47 43.561	122 45.687	09:45	HSEA	1	50/50	RE,SI,LO	F,L,OC	0
13-Sep-11	09:11	12:23	47 46.893	122 44.01	10:36	HSEA	1	50/90	LO,SI	F,OC	1
13-Sep-11	09:11	12:23	47 46.43	122 44.285	10:52	HSEA	1	125/358	LO,SW,SI	F,OC	0
13-Sep-11	09:11	12:23	47 46.49	122 44.285	10:53	HSEA	1	110/250	SW,DI,LO	F,OC	0
13-Sep-11	09:11	12:23	47 45.288	122 45.064	11:15	HSEA	1	200/200	SW,LO,DI	F,OC	0
13-Sep-11	09:11	12:23	47 44.966	122 44.74	11:19	HSEA	1	80/300	DI,LO,SI	F,OC	1
13-Sep-11	09:11	12:23	47 44.734	122 44.639	11:21	CASL	1	210/100	HO	F,OC	1
13-Sep-11	09:11	12:23	47 44.523	122 45.421	11:26	HSEA	1	250/284	LO,SI	F,OC	0



Date:	Time Observation Initiated:	Time Observation Completed:	Latitude	Longitude	Sighting Time	Species	# of Anim(s)	Dist./Dir. to Ani(s)	Behavior Type	Weather Conditions	Beaufort
13-Sep-11	09:11	12:23	47 42.635	122 45.139	11:58	HSEA	1	35/255	LO,SW,DI	F,OC	1
13-Sep-11	09:11	12:23	47 42.509	122 45.715	12:04	HSEA	1	200/139	LO,SW	F,OC	1
13-Sep-11	09:11	12:23	47 41.978	122 45.961	12:15	HPOR	3	750/200	SW,TR	F,L,OC	0
13-Sep-11	09:11	12:23	47 41.706	122 45.422	12:18	HSEA	2	100/174	TR,SW,DI	F,L,OC	0
13-Sep-11	09:11	12:23	47 41.489	122 44.992	12:21	HSEA	1	120/154	LO,SI	F,L,OC	0
14-Sep-11	08:10	11:45	47 43.02	122 45.83	08:31	HSEA	1	50/140	RE,LO,SI	OC	2
14-Sep-11	08:10	11:45	47 42.593	122 45.188	08:38	HSEA	1	95/210	LO	OC	2
14-Sep-11	08:10	11:45	47 41.907	122 45.867	08:54	HSEA	1	150/210	LO,SI	OC	2
14-Sep-11	08:10	11:45	47 41.512	122 45.432	09:04	HSEA	1	165/190	LO,SI	OC	2
14-Sep-11	08:10	11:45	47 42.565	122 46.066	09:23	HPOR	2	150/38	TR	OC	2
14-Sep-11	08:10	11:45	47 42.749	122 46.016	09:45	HSEA	1	100/253	LO,SI	OC	2
14-Sep-11	08:10	11:45	47 44.044	122 46.089	09:50	HSEA	1	75/34	LO,SI	OC	2
14-Sep-11	08:10	11:45	47 45.277	122 44.162	10:09	CASL	1	500/81	HO	OC	2
14-Sep-11	08:10	11:45	47 46.244	122 43.324	10:23	HPOR	2	100/143	MI	OC	2
14-Sep-11	08:10	11:45	47 47.031	122 44.315	10:36	HPOR	3	300/205	TR,MI	OC	2
14-Sep-11	08:10	11:45	47 44.865	122 44.65	11:19	CASL	8	500/80	HO	OC	2
14-Sep-11	08:10	11:45	47 44.865	122 44.65	11:19	HSEA	1	100/99	LO,SW,MI,DI	OC	2
14-Sep-11	08:10	11:45	47 44.215	122 45.546	11:31	HSEA	1	500/300	LO,SI	OC	2
19-Sep-11	08:10	11:49	47 43.644	122 44.662	08:16	HSEA	1	400/215	LO	PC	1
19-Sep-11	08:10	11:49	47 43.644	122 44.662	08:19	HSEA	1	150/182	SW,DI	PC	1
19-Sep-11	08:10	11:49	47 42.963	122 46.436	08:29	HSEA	1	400/315	SW,SI	PC	0
19-Sep-11	08:10	11:49	47 42.767	122 46.465	08:33	HSEA	1	1500/143	TR(N),DI	PC	0
19-Sep-11	08:10	11:49	47 42.107	122 45.017	08:43	HSEA	1	500/205	LO,SW,SI,DI	PC	0
19-Sep-11	08:10	11:49	47 41.928	122 45.236	08:46	HSEA	2	225/350	LO,SI	PC	0
19-Sep-11	08:10	11:49	47 41.791	122 45.625	08:48	HSEA	1	100/352	LO,DI	PC	0
19-Sep-11	08:10	11:49	47 41.444	122 45.003	08:57	HSEA	1	400/165	LO,RE	PC	0
19-Sep-11	08:10	11:49	47 41.592	122 45.178	09:01	HSEA	1	110/205	LO,SI,SW(E)	PC	0
19-Sep-11	08:10	11:49	47 42.386	122 46.863	09:13	HSEA	1	320/25	RE	PC	0
19-Sep-11	08:10	11:49	47 43.452	122 46.655	09:35	HSEA	1	120/20	LO,SI	PC	0
19-Sep-11	08:10	11:49	47 43.958	122 45.281	09:48	HSEA	1	75/45	RE,SI	PC	0
19-Sep-11	08:10	11:49	47 44.36	122 45.783	09:52	HSEA	1	200/10	LO,SI	PC	0
19-Sep-11	08:10	11:49	47 44.876	122 44.622	10:02	CASL	6	500/120	HO	PC	0
19-Sep-11	08:10	11:49	47 45.74	122 44.057	10:15	HSEA	1	75/190	LO,SI	PC	0
19-Sep-11	08:10	11:49	47 46.751	122 43.047	10:35	HSEA	1	350/35	LO,SI	PC	0
20-Sep-11	08:21	12:11	47 45.488	122 45.14	08:27	HSEA	1	400/350	SW,SI	S	1
20-Sep-11	08:21	12:11	47 46.515	122 44.23	08:44	HPOR	3	100/52	MI	S	1

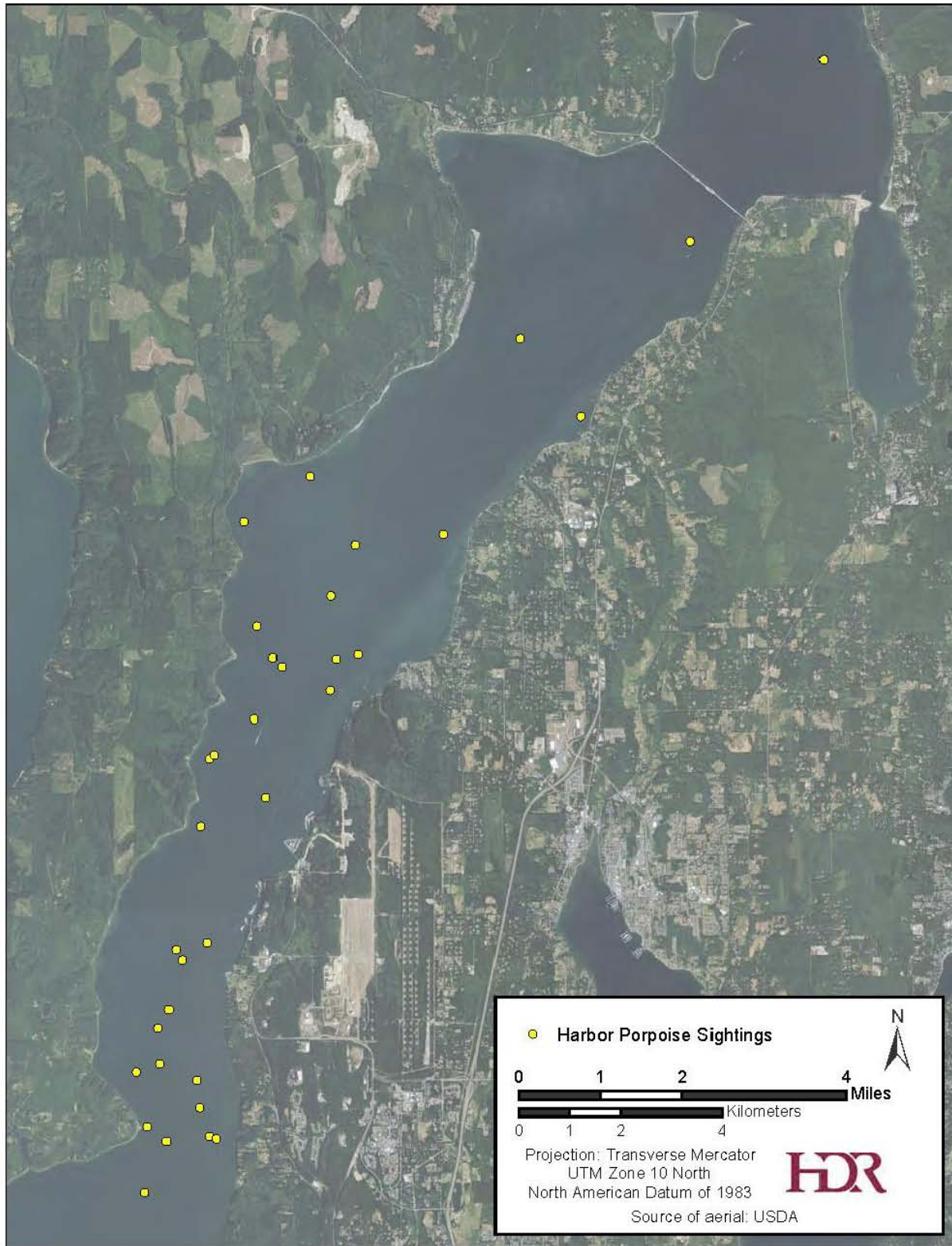
Date:	Time Observation Initiated:	Time Observation Completed:	Latitude	Longitude	Sighting Time	Species	# of Anim(s)	Dist./Dir. to Ani(s)	Behavior Type	Weather Conditions	Beaufort
20-Sep-11	08:21	12:11	47 46.767	122 42.792	08:55	HSEA	1	400/355	LO,SI	S	1
20-Sep-11	08:21	12:11	47 48.412	122 43.397	09:12	HPOR	5	250/296	MI	S	1
20-Sep-11	08:21	12:11	47 47.772	122 44.519	09:24	HSEA	1	75/159	LO,SI	S	1
20-Sep-11	08:21	12:11	47 46.346	122 43.626	09:38	HSEA	1	400/93	SW,DI	S	1
20-Sep-11	08:21	12:11	47 45.14	122 44.487	09:58	CASL	1	300/115	MI	S	1
20-Sep-11	08:21	12:11	47 44.357	122 45.007	10:08	CASL	6	1000/48	RE	S	1
20-Sep-11	08:21	12:11	47 43.132	122 45.279	10:26	HSEA	1	350/120	RE	S	1
20-Sep-11	08:21	12:11	47 42.951	122 46.435	10:33	HSEA	1	105/5	RE,LO	S	1
20-Sep-11	08:21	12:11	47 42.082	122 44.97	10:47	HSEA	1	500/350	SW,DI	S	1
20-Sep-11	08:21	12:11	47 41.807	122 45.601	10:52	HSEA	1	50/165	LO,SI	S	1
20-Sep-11	08:21	12:11	47 41.734	122 45.543	11:06	HSEA	1	150/212	SW,SI	S	1
20-Sep-11	08:21	12:11	47 43.632	122 45.512	11:44	HSEA	1	400/25	LO,SI	S	1
20-Sep-11	08:21	12:11	47 44.338	122 44.865	12:09	CASL	16	1000/55	RE	S	1
27-Sep-11	08:30	12:22	47 43.655	122 45.09	08:30	HPOR	6	280/215	TR	PC	1
27-Sep-11	08:30	12:22	47 43.282	122 45.217	10:00	HSEA	1	60/005	RE,SI	PC	2
27-Sep-11	08:30	12:22	47 46.135	122 43.756	10:40	HSEA	1	120/110	LO,SI	PC	2
27-Sep-11	08:30	12:22	47 46.545	122 43.827	10:46	HSEA	1	50/55	SW,DI	PC	2
27-Sep-11	08:30	12:22	47 47.685	122 44.311	10:58	HSEA	1	100/360	RE,LO,SI	PC	2
27-Sep-11	08:30	12:22	47 47.512	122 43.98	11:06	HSEA	1	220/65	SW,DI	PC	2
27-Sep-11	08:30	12:22	47 45.046	122 44.808	11:47	HSEA	1	250/115	SW	PC	3
27-Sep-11	08:30	12:22	47 44.475	122 43.376	11:56	CASL	27	200/90	RE	PC	3
28-Sep-11	08:50	12:30	47 45.472	122 45.155	08:50	HPOR	2	40/330	TR,CD	pc	1
28-Sep-11	08:50	12:30	47 45.472	122 45.155	08:57	HPOR	5	125/35	TR	pc	1
28-Sep-11	08:50	12:30	47 45.472	122 45.155	08:58	HSEA	1	150/005	LO,RE	pc	1
28-Sep-11	08:50	12:30	47 46.673	122 43.274	09:25	HSEA	1	400/70	LO,SI	F	1
28-Sep-11	08:50	12:30	47 46.791	122 43.117	09:29	HSEA	1	250/80	LO,SI	F	1
28-Sep-11	08:50	12:30	47 46.815	122 46.285	09:41	HPOR	3	500/120	MI	pc	2
28-Sep-11	08:50	12:30	47 46.205	122 43.403	09:50	HSEA	1	110/230	LO,SI	pc	2
28-Sep-11	08:50	12:30	47 44.945	122 45.229	10:28	HSEA	1	120/230	LO,SW,SI	pc	2
28-Sep-11	08:50	12:30	47 42.333	122 45.544	11:12	CASL	1	80/120	DI	pc	3
28-Sep-11	08:50	12:30	47 41.802	122 45.671	11:21	HSEA	1	30/240	RE,LO,SI	pc	3
28-Sep-11	08:50	12:30	47 41.51	122 45.242	11:28	HPOR	1	75/120	SW	pc	3
28-Sep-11	08:50	12:30	47 42.397	122 46.463	11:43	HSEA	1	70/110	SW,LO,SI	pc	3
21-Oct-11	09:05	12:00	47 41.478	122 45.069	09:40	HPOR	2	35m/210	SW(330)	OC	4
21-Oct-11	09:05	12:00	47 41.841	122 46.386	09:53	HSEA	1	25m/120	SW	OC	4
21-Oct-11	09:05	12:00	47 41.841	122 46.386	09:54	CASL	1	40m/290	SW	OC	4

Date:	Time Observation Initiated:	Time Observation Completed:	Latitude	Longitude	Sighting Time	Species	# of Anim(s)	Dist./Dir. to Ani(s)	Behavior Type	Weather Conditions	Beaufort
21-Oct-11	09:05	12:00	47 42.141	122 46.765	09:56	HSEA	1	100m/340	SW(120), SI	OC	2
21-Oct-11	09:05	12:00	47 42.952	122 46.832	10:10	HSEA	1	60m/320	LO,SI	OC	2
21-Oct-11	09:05	12:00	47 42.138	122 46.962	11:20	HSEA	10	80m/030	RE	OC	4
21-Oct-11	09:05	12:00			11:40	CASL	22		RE	OC	4
22-Oct-11	09:18	11:25	47 43.541	122 44.744	09:22	CASL	1	250/230	LO(n),SW(n)	l,oc,fog	1
22-Oct-11	09:18	11:25	47 43.156	122 45.097	09:26	HSEA	1	50/190	SW(e),DI(e)	l,oc,fog	1
22-Oct-11	09:18	11:25	47 42.31	122 44.976	09:35	CASL	1	75/355	SW(n),DI(n)	l,oc,fog	2
22-Oct-11	09:18	11:25	47 41.455	122 45.585	09:45	CASL	1	200/230	SW(nw),DI(nw)	l,oc,fog	2
22-Oct-11	09:18	11:25	47 42.032	122 46.615	09:53	CASL	1	120/300	RE,DI	l,oc,fog	2
22-Oct-11	09:18	11:25	47 46.656	122 42.914	11:02	HPOR	1	175/140	TR(s)	l,oc,fog	1
22-Oct-11	09:18	11:25	47 46.279	122 42.968	11:05	HSEA	3	350/70	RE,DI	l,oc,fog	1
22-Oct-11	09:18	11:25	47 44.73	122 44.346	11:19	CASL	26	200/110	RE,DI	l,oc,fog	1
22-Oct-11	09:18	11:25	47 44.287	122 44.61	11:22	HSEA	1	30/185	LO,DI	l,oc,fog	1
24-Oct-11	09:30	13:00	47 42.724	122 45.446	09:44	HSEA	1	70m/120	RE,SI	OC	2
24-Oct-11	09:30	13:00			09:46	CASL	1	50m/110	DI	PC	2
24-Oct-11	09:30	13:00	47 41.599	122 46.105	10:34	CASL	1	38m/273	DI(340)	PC	2
24-Oct-11	09:30	13:00	47 46.075	122 44.219	11:39	HSEA	1	75m/140	FO	PC	2
24-Oct-11	09:30	13:00	47 46.237	122 42.877	11:49	HSEA	9	100m/065	RE	PC	2
24-Oct-11	09:30	13:00	47 44.651	122 44.789	12:40	CASL	22	200m/090	RE	PC	2
25-Oct-11	09:38	12:40	47 44.317	122 45.317	09:45	HSEA	1	175/220	SW(s),DI(s)	fog	1
25-Oct-11	09:38	12:40	47 44.569	122 45.19	09:52	HSEA	1	100/180	RE	fog	1
25-Oct-11	09:38	12:40	47 45.367	122 44.284	10:02	HSEA	1	200/305	LO(s),SI	pc	1
25-Oct-11	09:38	12:40	47 46.73	122 44.284	10:38	HSEA	1	150/150	LO(n),SI	pc	1
25-Oct-11	09:38	12:40	47 45.222	122 44.2	11:02	CASL	1	325/65	RE	pc	1
25-Oct-11	09:38	12:40	47 44.38	122 44.972	11:12	CASL	28	500-750/43-65	RE	pc	1
25-Oct-11	09:38	12:40	47 42.792	122 46.446	11:38	CASL	1	175/214	FO	pc	1
25-Oct-11	09:38	12:40	47 42.721	122 46.286	11:39	CASL	1	75/140	DI,FO	pc	1
25-Oct-11	09:38	12:40	47 42.148	122 45.189	11:46	HSEA	1	75/235	LO(w),SI	pc	1
25-Oct-11	09:38	12:40	47 41.558	122 45.047	12:01	HSEA	1	125/335	SW(e),DI(e)	pc	1
26-Oct-11	11:30	14:00	47 45.275	122 45.033	11:46	CASL	31	300m*	RE	PC	4
26-Oct-11	11:30	14:00	47 45.275	122 45.033	11:46	STSL	1	500m*	RE	PC	4



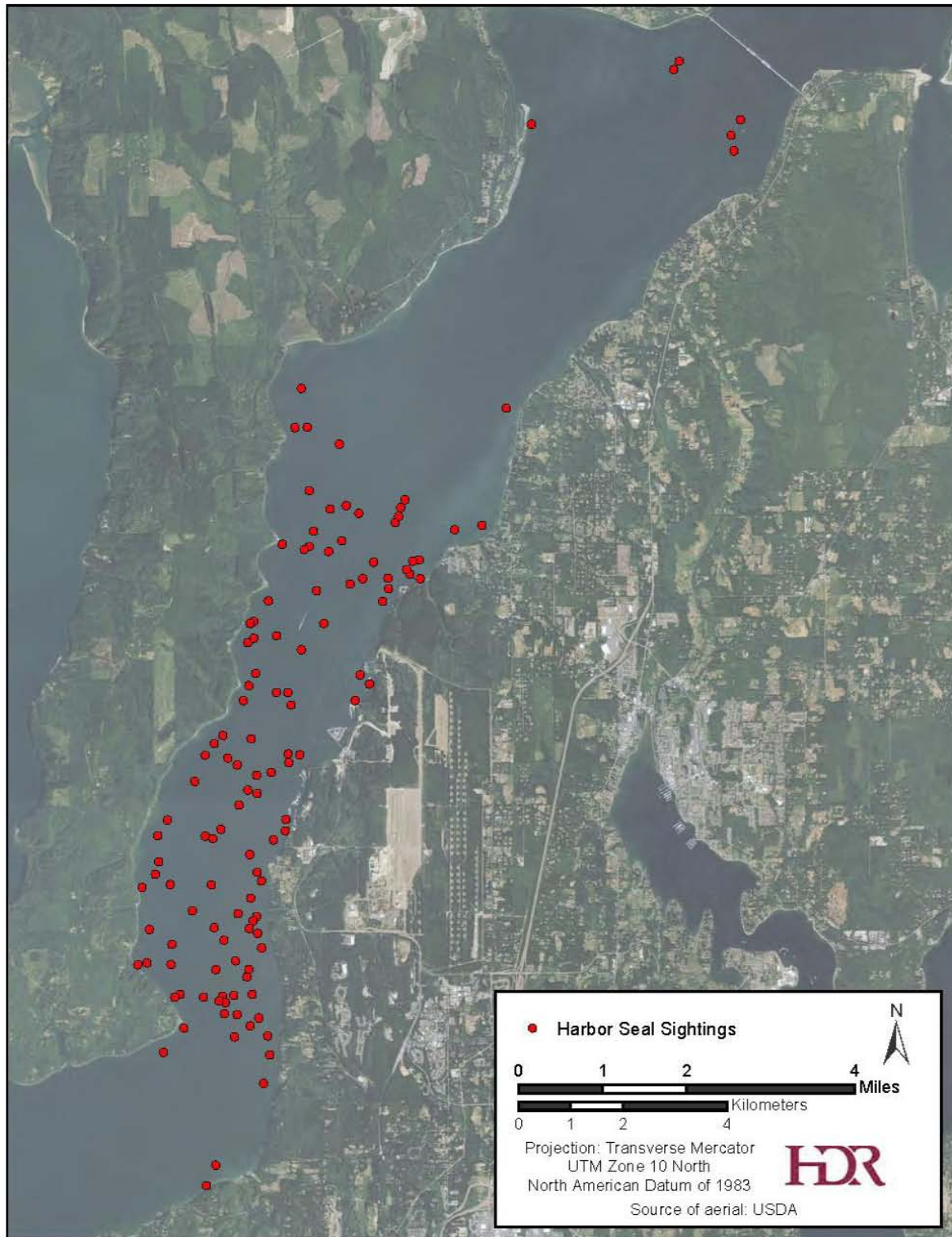
**Figure B-3. All California sea lion sightings during Hood Canal Surveys. Points may represent more than one individual.**





**Figure B-4. All harbor porpoise sightings during Hood Canal Surveys. Points may represent more than one individual.**

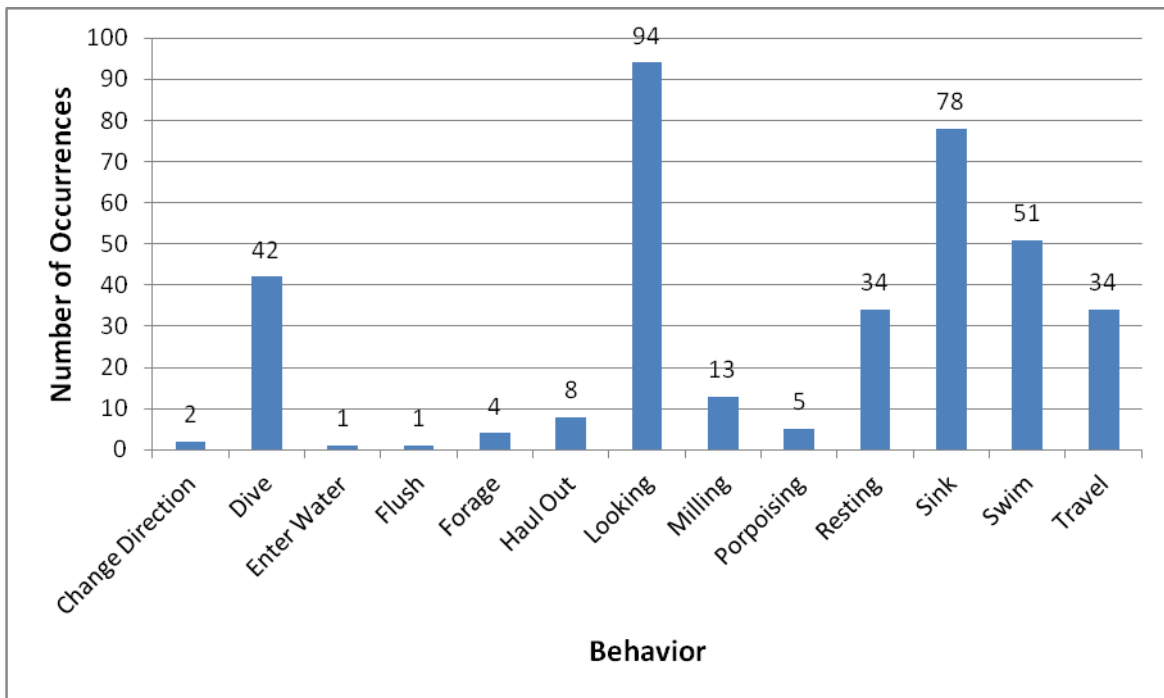




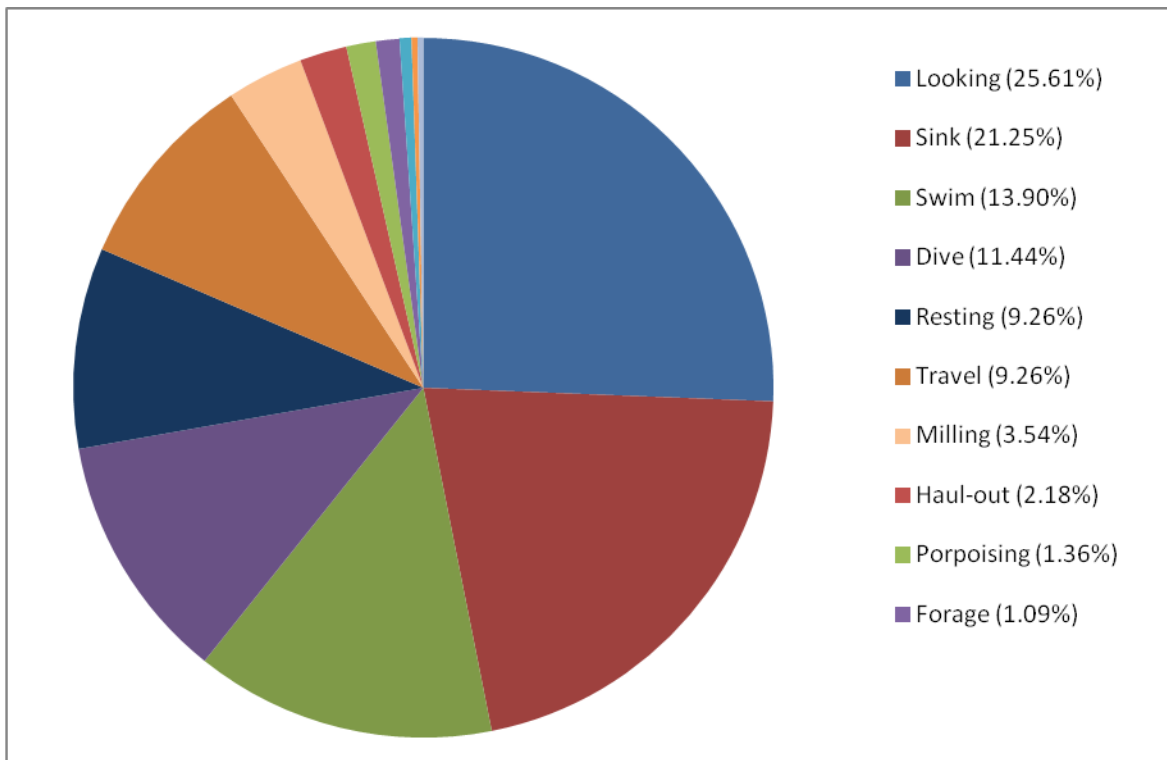
**Figure B-5. All harbor seal sightings during Hood Canal Surveys. Points may represent more than one individual.**



**Figure B-6. Steller sea lion and northern river otter sightings during Hood Canal Surveys. Points may represent more than one individual.**



**Figure B-7. Number of Behaviors Observed During Hood Canal Surveys**



**Figure B-8. Percentage of Behaviors Observed During Hood Canal Surveys**



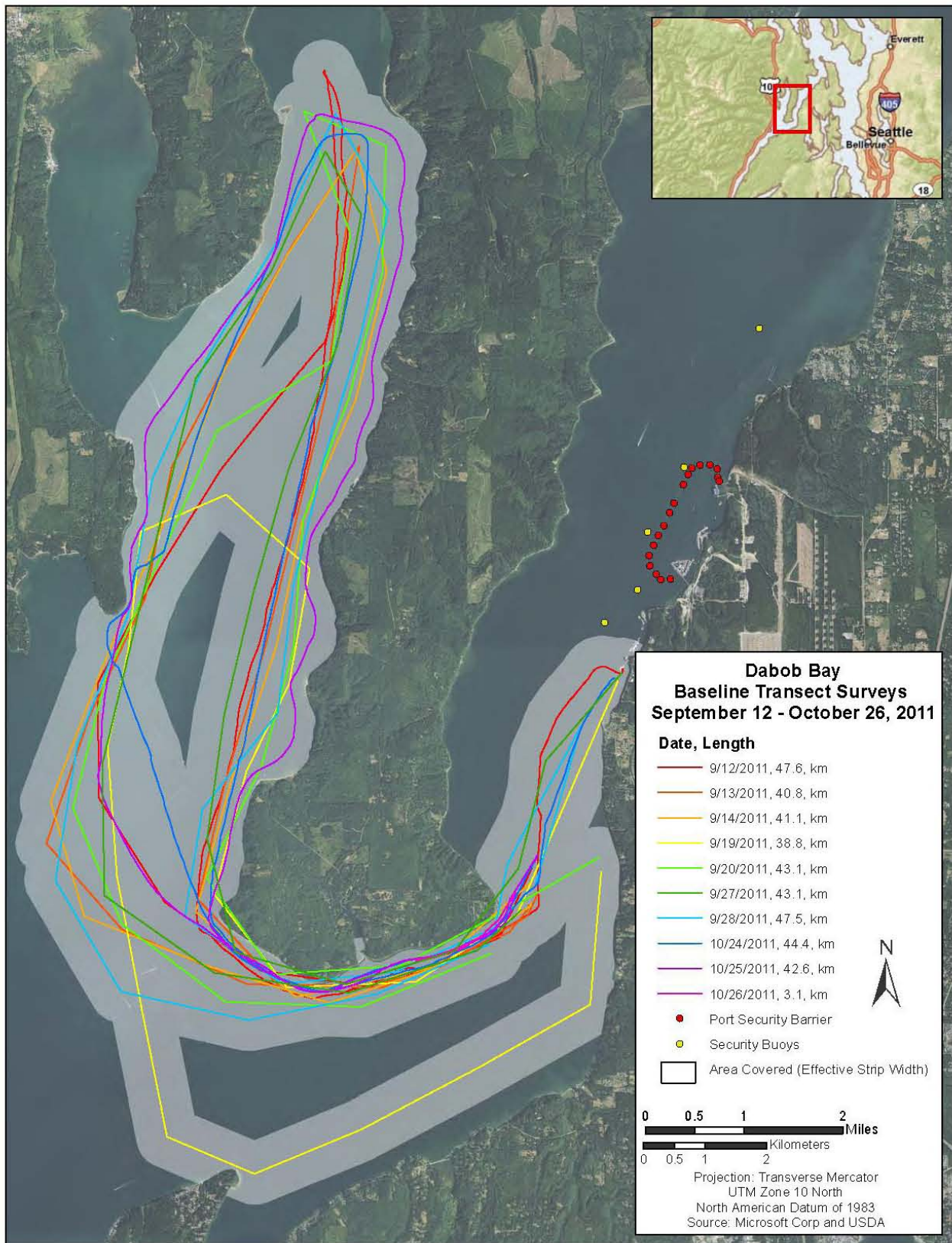


Figure B-9. All survey transects and 1,640 ft (500 m) strip width for Dabob Bay

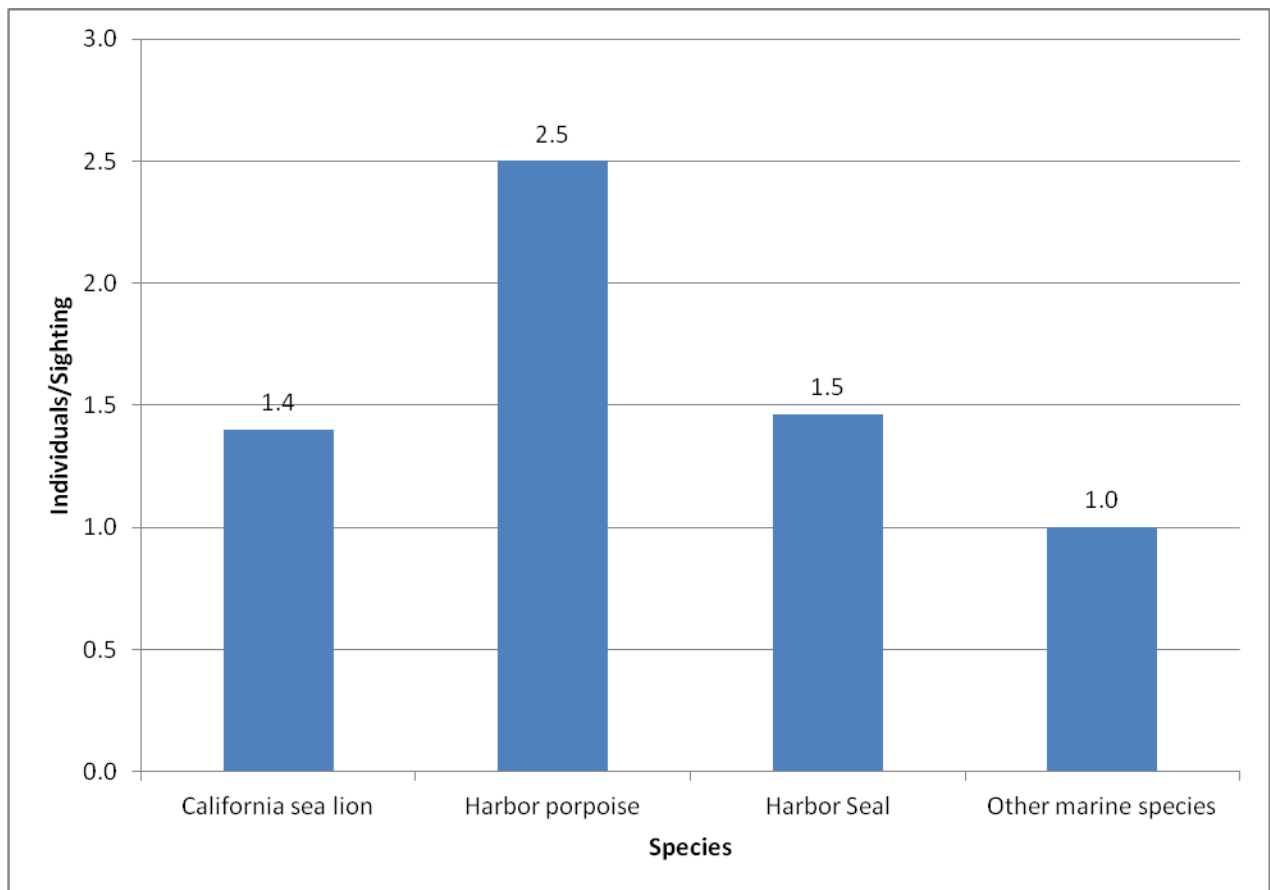
**Table B-4. Summary of the Transect and Sightings Data for Dabob Bay**

Date	Day Type	Area Covered (km <sup>2</sup> )	Trackline Length (km)	Total Survey Time (hh:min)	Total Survey Time (hours)	Species	# of Sightings	# of Animals	Sighting Frequency
									Individuals/km <sup>2</sup> /hour
12-Sep-2011	Transect	34.8	47.6	03:16	3.267	CASL	1	1	0.009
						HPOR	2	4	0.018
						HSEA	16	19	0.141
13-Sep-2011	Transect	33.5	40.8	03:24	3.400	HSEA	51	55	0.448
						HPOR	5	18	0.044
14-Sep-2011	Transect	33.7	41.1	03:18	3.300	HPOR	3	4	0.027
						HSEA	50	58	0.450
19-Sep-2011	Transect	35.0	38.8	03:10	3.170	OTHR	1	1	0.009
						HSEA	59	85	0.532
20-Sep-2011	Transect	36.0	43.1	03:28	3.467	CASL	1	1	0.008
						HPOR	2	4	0.016
						HSEA	65	85	0.521
27-Sep-2011	Transect	36.0	43.1	03:15	3.250	HSEA	5	14	0.043
28-Sep-2011	Transect	40.0	47.5	03:27	3.450	CASL	1	1	0.007
						HPOR	1	4	0.007
						HSEA	19	49	0.138
24-Oct-2011	Transect	34.3	44.4	02:50	2.833	HSEA	8	11	0.082
25-Oct-2011	Transect	29.5	42.6	03:15	3.250	CASL	2	4	0.021
						HSEA	28	65	0.292
26-Oct-2011	Transect	2.2	3.1	00:17	0.283	HSEA	1	1	1.606



**Table B-5. Total Number of Sightings and Animals in Dabob Bay**

Species	# of Sightings	# of Animals
California sea lion	5	7
Harbor porpoise	12	30
Harbor seal	302	442
UNID Pinniped	1	1
<b>TOTAL</b>	<b>320</b>	<b>480</b>



**Figure B-10. Mean Number of Animals per Sighting (by Species) During Dabob Bay Surveys**

Table B-6. All Sightings Data from Dabob Bay

Date:	Time Observation Initiated:	Time Observation Completed:	Latitude	Longitude	Sighting Time	Species	# of Anim(s)	Dist./Dir. to Ani(s)	Behavior Type	Weather Conditions	Beaufort
12-Sep-11	08:56	12:12	47 41.0170	122 49.488	09:22	HSEA	1	120/67		OC	2
12-Sep-11	08:56	12:12	47 41.6550	122 50.201	09:30	HSEA	1	85/30		OC	2
12-Sep-11	08:56	12:12	47 42.2160	122 49.858	09:39	CASL	1	400/355		OC	1
12-Sep-11	08:56	12:12	47 46.3180	122 48.548	10:11	HSEA	1	275/ 373		OC	1
12-Sep-11	08:56	12:12	47 48.1960	122 48.39	10:27	HSEA	1	70/290		OC	1
12-Sep-11	08:56	12:12	47 48.4820	122 48.417	10:30	HSEA	2	90/70		OC	1
12-Sep-11	08:56	12:12	47 47.9780	122 48.261	10:47	HPOR	2	125/68		OC	1
12-Sep-11	08:56	12:12	47 47.2980	122 48.27	10:53	HSEA	1	300/275		OC	1
12-Sep-11	08:56	12:12	47 44.7450	122 50.543	11:22	HSEA	2	65/205		OC	2
12-Sep-11	08:56	12:12	47 44.3350	122 50.896	11:26	HSEA	1	125/98		OC	2
12-Sep-11	08:56	12:12	47 43.6910	122 51.428	11:33	HSEA	2	100/235		OC	2
12-Sep-11	08:56	12:12	47 43.4640	122 51.556	11:35	HSEA	1	150/90		OC	2
12-Sep-11	08:56	12:12	47 42.5520	122 51.474	11:43	HSEA	1	150/80		OC	2
12-Sep-11	08:56	12:12	47 41.9610	122 50.946	11:50	HSEA	1	100/95		OC	1
12-Sep-11	08:56	12:12	47 41.4010	122 50.291	11:57	HSEA	1	25/312		OC	1
12-Sep-11	08:56	12:12	47 41.0900	122 49.538	12:03	HSEA	1	100/350		OC	1
12-Sep-11	08:56	12:12	47 41.0200	122 49.34	12:04	HSEA	1	50/100		OC	1
12-Sep-11	08:56	12:12	47 41.0200	122 49.34	12:05	HPOR	2	100/330		OC	1
12-Sep-11	08:56	12:12	47 40.7910	122 48.922	12:09	HSEA	1	120/45		OC	1
13-Sep-11	08:56	12:20	47 41.4340	122 46.092	08:57	HPOR	6	500/210	PO,SW	F	0
13-Sep-11	08:56	12:20	47 41.2080	122 46.651	09:01	HSEA	1	300/227	RE,DI	F	0
13-Sep-11	08:56	12:20	47 41.1140	122 46.893	09:02	HPOR	6	200/240	TR	F	0
13-Sep-11	08:56	12:20	47 41.0800	122 47.015	09:05	HSEA	1	50/15	RE	F	0
13-Sep-11	08:56	12:20	47 41.0000	122 47.024	09:07	HSEA	1	100/200	LO,SI	F	0
13-Sep-11	08:56	12:20	47 41.0910	122 47.012	09:08	HSEA	1	150/290	TR	F	0
13-Sep-11	08:56	12:20	47 41.0160	122 47.511	09:13	HSEA	1	250/237	LO,SI	F	1
13-Sep-11	08:56	12:20	47 41.9220	122 47.608	09:14	HSEA	1	150/220	RE	F	1
13-Sep-11	08:56	12:20	47 40.7610	122 48.615	09:22	HPOR	2	125/235	TR	OC	1
13-Sep-11	08:56	12:20	47 40.8220	122 48.922	09:25	HSEA	1	100/210	RE	OC	1
13-Sep-11	08:56	12:20	47 40.9250	122 49.236	09:26	HSEA	1	400/292	SI	OC	1
13-Sep-11	08:56	12:20	47 40.9350	122 49.207	09:27	HSEA	1	100/240	SW	OC	1
13-Sep-11	08:56	12:20	47 41.2840	122 50.065	09:32	HSEA	1	200/333	SW	OC	1
13-Sep-11	08:56	12:20	47 41.3020	122 50.091	09:33	HSEA	1	220/311	RE,DI	OC	1

Date:	Time Observation Initiated:	Time Observation Completed:	Latitude	Longitude	Sighting Time	Species	# of Anim(s)	Dist./Dir. to Ani(s)	Behavior Type	Weather Conditions	Beaufort
13-Sep-11	08:56	12:20	47 40.4070	122 50.174	09:34	HSEA	1	150/207	SW,DI	OC	1
13-Sep-11	08:56	12:20	47 42.1080	122 50.089	09:40	HPOR	2	125/22	TR	OC	1
13-Sep-11	08:56	12:20	47 42.4660	122 49.963	09:44	HSEA	1	150/65	SW,LO	OC	1
13-Sep-11	08:56	12:20	47 42.6220	122 49.886	09:45	HSEA	1	400/344	SI	OC	1
13-Sep-11	08:56	12:20	47 42.7440	122 49.67	09:47	HSEA	2	300/85	SW,LO,DI	OC	1
13-Sep-11	08:56	12:20	47 42.8670	122 49.749	09:48	HSEA	1	500/85	SI	OC	1
13-Sep-11	08:56	12:20	47 43.0810	122 49.63	09:50	HSEA	2	450/100	SW	OC	1
13-Sep-11	08:56	12:20	47 43.8880	122 49.322	09:57	HSEA	1	250/80	SW,DI	OC	1
13-Sep-11	08:56	12:20	47 44.6550	122 49.019	10:04	HSEA	1	300/15	LO,SI	OC	1
13-Sep-11	08:56	12:20	47 44.9140	122 48.928	10:06	HSEA	1	250/60	DI	OC	1
13-Sep-11	08:56	12:20	47 45.9450	122 48.547	10:15	HSEA	1	175/48	SW	OC	1
13-Sep-11	08:56	12:20	47 46.1530	122 48.502	10:16	HSEA	1	100/08	RE	OC	1
13-Sep-11	08:56	12:20	47 46.5160	122 48.434	10:18	HSEA	1	200/290	SW	OC	1
13-Sep-11	08:56	12:20	47 46.4240	122 48.441	10:19	HSEA	1	100/90	DI	OC	1
13-Sep-11	08:56	12:20	47 46.8900	122 48.41	10:19	HSEA	1	300/100	SI	OC	1
13-Sep-11	08:56	12:20	47 47.3920	122 48.263	10:26	HSEA	1	400/118	RE	OC	1
13-Sep-11	08:56	12:20	47 48.2120	122 48.485	10:40	HSEA	1	300/176	DI	OC	1
13-Sep-11	08:56	12:20	47 48.0970	122 48.629	10:40	HSEA	1	400/182	RE	OC	1
13-Sep-11	08:56	12:20	47 47.4890	122 48.778	10:44	HPOR	2	375/172	TR	OC	1
13-Sep-11	08:56	12:20	47 47.6550	122 48.842	10:45	HSEA	1	125/95	LO	OC	1
13-Sep-11	08:56	12:20	47 47.2970	122 49.013	10:47	HSEA	1	600/175	RE,DI	OC	1
13-Sep-11	08:56	12:20	47 47.1310	122 49.075	10:50	HSEA	1	285/218	RE	OC	1
13-Sep-11	08:56	12:20	47 46.8940	122 49.272	10:52	HSEA	1	125/137	DI,SW	OC	1
13-Sep-11	08:56	12:20	47 46.7500	122 49.392	10:54	HSEA	1	100/240	RE	OC	1
13-Sep-11	08:56	12:20	47 46.4600	122 49.737	10:56	HSEA	2	500/295	UN	OC	1
13-Sep-11	08:56	12:20	47 46.3050	122 50.056	10:59	HSEA	1	75/165	LO,SI	OC	1
13-Sep-11	08:56	12:20	47 44.9640	122 50.683	11:11	HSEA	1	500/140	RE,SI	OC	1
13-Sep-11	08:56	12:20	47 44.8080	122 50.726	11:12	HSEA	1	100/90	LO,SI	OC	1
13-Sep-11	08:56	12:20	47 44.8080	122 50.726	11:13	HSEA	1	125/182	LO,SI	OC	1
13-Sep-11	08:56	12:20	47 44.5510	122 50.799	11:15	HSEA	1	100/157	SI	OC	1
13-Sep-11	08:56	12:20	47 44.3450	122 50.863	11:16	HSEA	1	300/204	SW,SI	OC	1
13-Sep-11	08:56	12:20	47 44.2410	122 50.929	11:18	HSEA	1	125/242	SI,SW	OC	1
13-Sep-11	08:56	12:20	47 43.6570	122 51.364	11:23	HSEA	1	150/115	RE	OC	1
13-Sep-11	08:56	12:20	47 43.5350	122 51.424	11:25	HSEA	1	175/205	DI	OC	1
13-Sep-11	08:56	12:20	47 42.7130	122 51.948	11:32	HSEA	1	200/190	RE,LO,SI	OC	1

Date:	Time Observation Initiated:	Time Observation Completed:	Latitude	Longitude	Sighting Time	Species	# of Anim(s)	Dist./Dir. to Ani(s)	Behavior Type	Weather Conditions	Beaufort
13-Sep-11	08:56	12:20	47 42.5210	122 52.044	11:33	HSEA	1	125/185	RE,LO	OC	1
13-Sep-11	08:56	12:20	47 42.6210	122 51.997	11:34	HSEA	1	50/110	DI	OC	1
13-Sep-11	08:56	12:20	47 42.1150	122 52.183	11:37	HSEA	1	125/205	RE,SI,LO	OC	1
13-Sep-11	08:56	12:20	47 41.4520	122 51.313	11:46	HSEA	1	200/55	SW,LO	OC	1
13-Sep-11	08:56	12:20	47 40.9260	122 49.607	11:57	HSEA	1	25/200	SW	OC	0
13-Sep-11	08:56	12:20	47 40.8250	122 49.214	11:59	HSEA	2	100/80	RE,SI,LO, SW	OC	0
13-Sep-11	08:56	12:20	47 41.2380	122 46.462	12:14	HSEA	1	75/282	TR	OC	0
14-Sep-11	08:38	11:56	47 41.4810	122 45.863	08:38	HSEA	1	50/85	SW	PC	2
14-Sep-11	08:38	11:56	47 41.3470	122 46.075	08:40	HPOR	1	600/195	SW	PC	2
14-Sep-11	08:38	11:56	47 41.0000	122 47.387	08:49	HSEA	1	125/268	LO,SI	PC	1
14-Sep-11	08:38	11:56	47 41.0290	122 47.228	08:49	HPOR	2	900/242	SW	PC	1
14-Sep-11	08:38	11:56	47 41.0000	122 47.387	08:50	HSEA	1	100/180	SW	PC	1
14-Sep-11	08:38	11:56	47 40.7760	122 48.29	08:56	HSEA	1	150/208	LO,SI	PC	1
14-Sep-11	08:38	11:56	47 40.7520	122 48.54	08:58	HPOR	1	700/280	SW	PC	1
14-Sep-11	08:38	11:56	47 40.9300	122 49.397	09:03	HSEA	1	125/195	LO,DI	PC	1
14-Sep-11	08:38	11:56	47 40.9950	122 49.73	09:05	HSEA	1	400/003	LO	PC	1
14-Sep-11	08:38	11:56	47 41.0680	122 50.019	09:07	HSEA	1	1000/186	LO	PC	1
14-Sep-11	08:38	11:56	47 41.1340	122 50.258	09:09	HSEA	1	10/000	LO,SI	PC	1
14-Sep-11	08:38	11:56	47 41.2670	122 50.827	09:12	HSEA	1	250/280	LO,SI	PC	1
14-Sep-11	08:38	11:56	47 41.4970	122 51.598	09:17	HSEA	1	75/23	LO	PC	1
14-Sep-11	08:38	11:56	47 42.0870	122 52.159	09:24	HSEA	1	20/270	SW	PC	1
14-Sep-11	08:38	11:56	47 42.6180	122 52.083	09:28	HSEA	1	400/30	DI	PC	1
14-Sep-11	08:38	11:56	47 42.8780	122 52.013	09:30	HSEA	1	350/359	LO,SI	PC	1
14-Sep-11	08:38	11:56	47 42.9710	122 51.984	09:31	HSEA	1	300/345	RE	PC	1
14-Sep-11	08:38	11:56	47 43.3180	122 51.734	09:34	HSEA	1	350/15	LO,DI	PC	1
14-Sep-11	08:38	11:56	47 43.7080	122 51.412	09:38	HSEA	1	350/15	LO,DI	PC	1
14-Sep-11	08:38	11:56	47 43.9200	122 51.216	09:40	HSEA	1	125/003	RE,DI	PC	1
14-Sep-11	08:38	11:56	47 44.0650	122 51.088	09:41	HSEA	8	200/340	RE,LO,SI, SW,DI	PC	1
14-Sep-11	08:38	11:56	47 44.4070	122 50.983	09:50	HSEA	1	80/030	LO,DI	PC	1
14-Sep-11	08:38	11:56	47 44.4900	122 50.934	09:51	HSEA	1	250/355	LO,SI	PC	1
14-Sep-11	08:38	11:56	47 44.6130	122 50.867	09:52	HSEA	1	120/94	RE	PC	1
14-Sep-11	08:38	11:56	47 44.6810	122 50.82	09:53	HSEA	1	450/020	LO	PC	1
14-Sep-11	08:38	11:56	47 44.8690	122 50.705	09:55	HSEA	1	250/140	RE	PC	1

Date:	Time Observation Initiated:	Time Observation Completed:	Latitude	Longitude	Sighting Time	Species	# of Anim(s)	Dist./Dir. to Ani(s)	Behavior Type	Weather Conditions	Beaufort
14-Sep-11	08:38	11:56	47 46.8360	122 49.43	10:13	HSEA	1	650/070	SW,DI,CD	PC	1
14-Sep-11	08:38	11:56	47 46.8960	122 49.386	10:13	HSEA	1	50/282	RE,LO	PC	1
14-Sep-11	08:38	11:56	47 47.0010	122 49.324	10:14	HSEA	1	550/090	LO,DI	PC	1
14-Sep-11	08:38	11:56	47 47.4800	122 48.911	10:18	HSEA	1	350/015	RE	PC	0
14-Sep-11	08:38	11:56	47 47.9580	122 48.731	10:23	HSEA	1	100/206	SW,LO	PC	0
14-Sep-11	08:38	11:56	47 47.9190	122 47.698	10:31	HSEA	1	160/085	RE,SI	PC	0
14-Sep-11	08:38	11:56	47 47.6450	122 47.666	10:34	HSEA	1	150/275	SW	PC	1
14-Sep-11	08:38	11:56	47 47.3680	122 47.685	10:36	HSEA	1	2/170	DI	PC	0
14-Sep-11	08:38	11:56	47 47.2870	122 47.699	10:37	HSEA	1	100/123	SI	PC	0
14-Sep-11	08:38	11:56	47 46.6100	122 47.956	10:43	HSEA	1	50/194	LO,SI	PC	1
14-Sep-11	08:38	11:56	47 45.4580	122 48.509	10:53	HSEA	1	400/185	LO,SI	PC	1
14-Sep-11	08:38	11:56	47 45.1580	122 48.719	10:56	HSEA	1	500/172	LO,DI,RE	PC	1
14-Sep-11	08:38	11:56	47 43.4700	122 49.384	11:10	HSEA	1	225/162	SW	PC	1
14-Sep-11	08:38	11:56	47 43.1170	122 49.537	11:13	HSEA	1	250/152	RE,LO	PC	1
14-Sep-11	08:38	11:56	47 42.7380	122 49.747	11:17	HSEA	1	400/160	LO,SI	PC	1
14-Sep-11	08:38	11:56	47 42.4950	122 49.855	11:19	HSEA	1	175/042	RE,LO	PC	1
14-Sep-11	08:38	11:56	47 42.2570	122 49.513	11:22	HSEA	1	75/090	RE,DI	PC	1
14-Sep-11	08:38	11:56	47 41.9500	122 50.065	11:24	HSEA	1	350/070	RE	PC	1
14-Sep-11	08:38	11:56	47 41.6930	122 50.188	11:27	HSEA	1	500/135	SI	PC	1
14-Sep-11	08:38	11:56	47 41.5240	122 50.243	11:28	HSEA	1	500/110	SW,SI	PC	1
14-Sep-11	08:38	11:56	47 41.1000	122 49.712	11:33	HSEA	1	300/055	RE,SW,DI	PC	1
14-Sep-11	08:38	11:56	47 41.0100	122 49.492	11:34	HSEA	2	350/090	SW,LO,SI	PC	1
14-Sep-11	08:38	11:56	47 40.8160	122 48.961	11:38	HSEA	1	1100/150	SW	PC	1
14-Sep-11	08:38	11:56	47 40.7970	122 48.633	11:39	HSEA	1	275/351	SW	PC	1
14-Sep-11	08:38	11:56	47 40.7900	122 48.375	11:40	HSEA	1	550/065	RE	PC	1
14-Sep-11	08:38	11:56	47 41.0260	122 47.282	11:47	HSEA	1	220/020	RE,SI	PC	1
14-Sep-11	08:38	11:56	47 41.1350	122 46.811	11:49	HSEA	1	120/085	RE,LO,SI	PC	1
19-Sep-11	08:35	11:45	47 41.2430	122 46.523	08:38	OTHR	1	600/227	SW,DI	PC	0
19-Sep-11	08:35	11:45	47 41.0310	122 47.009	08:41	HSEA	1	550/210	LO,SI	PC	0
19-Sep-11	08:35	11:45	47 40.9130	122 47.675	08:45	HSEA	1	210/295	LO,SW,SI	PC	0
19-Sep-11	08:35	11:45	47 40.9110	122 47.891	08:47	HSEA	1	700/257	SW,DI	PC	0
19-Sep-11	08:35	11:45	47 40.8560	122 48.328	08:49	HSEA	1	800/250	LO,SI,SW	PC	0
19-Sep-11	08:35	11:45	47 40.8980	122 49.068	08:54	HSEA	1	500/295	SW,SI	PC	0
19-Sep-11	08:35	11:45	47 41.1380	122 49.634	08:58	HSEA	8	900/315	SW,DI,LO	PC	0
19-Sep-11	08:35	11:45	47 41.4310	122 50.064	09:01	HSEA	1	350/305	LO,DI	PC	0



Date:	Time Observation Initiated:	Time Observation Completed:	Latitude	Longitude	Sighting Time	Species	# of Anim(s)	Dist./Dir. to Ani(s)	Behavior Type	Weather Conditions	Beaufort
19-Sep-11	08:35	11:45	47 41.6430	122 50.014	09:03	HSEA	1	275/010	LO,SI	PC	0
19-Sep-11	08:35	11:45	47 41.7740	122 49.964	09:04	HSEA	1	400/295	DI	PC	0
19-Sep-11	08:35	11:45	47 41.8990	122 49.926	09:05	HSEA	2	300/020	SW,LO,DI,SI	PC	0
19-Sep-11	08:35	11:45	47 42.0710	122 49.873	09:07	HSEA	1	650/340	SW,DI	PC	0
19-Sep-11	08:35	11:45	47 42.1520	122 49.85	09:08	HSEA	1	900/358	SW,DI	PC	0
19-Sep-11	08:35	11:45	47 42.3000	122 49.804	09:09	HSEA	1	250/012	SW,LO,SI	PC	0
19-Sep-11	08:35	11:45	47 42.6110	122 49.705	09:11	HSEA	2	200/055	SW,LO,DI,SI	PC	0
19-Sep-11	08:35	11:45	47 42.7510	122 49.598	09:13	HSEA	1	240/050	MI,DI	PC	0
19-Sep-11	08:35	11:45	47 42.8710	122 49.449	09:14	HSEA	1	200/065	SW	PC	0
19-Sep-11	08:35	11:45	47 42.9260	122 49.286	09:15	HSEA	1	20/085	LO,DI	PC	0
19-Sep-11	08:35	11:45	47 42.9370	122 49.252	09:16	HSEA	1	350/080	LO,SI	PC	0
19-Sep-11	08:35	11:45	47 42.9520	122 49.135	09:17	HSEA	1	160/160	RE,DI,SW,LO	PC	0
19-Sep-11	08:35	11:45	47 42.9680	122 49.039	09:17	HSEA	2	250/060	SW,LO,DI,SI	PC	1
19-Sep-11	08:35	11:45	47 43.1120	122 48.914	09:19	HSEA	2	60/300	SW	PC	1
19-Sep-11	08:35	11:45	47 43.1820	122 48.91	09:20	HSEA	1	55/300	SW	PC	1
19-Sep-11	08:35	11:45	47 43.3360	122 48.929	09:21	HSEA	1	500/290	RE,DI,	PC	1
19-Sep-11	08:35	11:45	47 43.4710	122 48.988	09:23	HSEA	1	150/280	LO,SI	PC	1
19-Sep-11	08:35	11:45	47 43.8830	122 48.76	09:26	HSEA	1	50/362	SW,LO,SI	PC	1
19-Sep-11	08:35	11:45	47 43.9660	122 48.686	09:27	HSEA	1	500/343	SW,DI	PC	1
19-Sep-11	08:35	11:45	47 44.1640	122 48.645	09:30	HSEA	1	30/210	LO,SW	PC	1
19-Sep-11	08:35	11:45	47 44.2690	122 48.716	09:31	HSEA	1	225/255	SW,DI	PC	1
19-Sep-11	08:35	11:45	47 44.5440	122 48.732	09:33	HSEA	3	400/350	RE,SW,DI	PC	0
19-Sep-11	08:35	11:45	47 44.7440	122 48.714	09:35	HSEA	1	300/364	SI	PC	0
19-Sep-11	08:35	11:45	47 45.0970	122 49.122	09:40	HSEA	2	110/200	SW,LO	PC	0
19-Sep-11	08:35	11:45	47 45.3350	122 50.43	09:47	HSEA	1	60/355	LO,SI	PC	0
19-Sep-11	08:35	11:45	47 45.3600	122 50.598	09:48	HSEA	1	300/250	RE,SI	PC	0
19-Sep-11	08:35	11:45	47 45.3060	122 50.598	09:50	HSEA	2	500/155	SI,RE	PC	1
19-Sep-11	08:35	11:45	47 45.2360	122 50.84	09:50	HSEA	1	700/153	LO	PC	1
19-Sep-11	08:35	11:45	47 44.9240	122 50.914	09:53	HSEA	2	400/194	LO,DI,SI	PC	1
19-Sep-11	08:35	11:45	47 44.9240	122 50.914	09:53	HSEA	2	400/174	LO,DI	PC	1
19-Sep-11	08:35	11:45	47 44.7330	122 51.064	09:55	HSEA	1	30/175	LO,SI	PC	1

Date:	Time Observation Initiated:	Time Observation Completed:	Latitude	Longitude	Sighting Time	Species	# of Anim(s)	Dist./Dir. to Ani(s)	Behavior Type	Weather Conditions	Beaufort
19-Sep-11	08:35	11:45	47 44.5510	122 51.062	09:57	HSEA	4	100/280	RE	PC	2
19-Sep-11	08:35	11:45	47 44.5510	122 51.062	09:58	HSEA	5	250/187	DI	PC	2
19-Sep-11	08:35	11:45	47 44.2860	122 51.068	09:58	HSEA	1	50/263	DI	PC	2
19-Sep-11	08:35	11:45	47 42.3020	122 51.298	10:20	HSEA	2	500/184	SW	PC	0
19-Sep-11	08:35	11:45	47 42.2050	122 51.291	10:21	HSEA	1	225/180	RE	PC	0
19-Sep-11	08:35	11:45	47 41.7180	122 51.22	10:25	HSEA	1	500/110	RE	PC	1
19-Sep-11	08:35	11:45	47 41.6440	122 51.208	10:26	HSEA	1	200/136	RE	PC	1
19-Sep-11	08:35	11:45	47 41.1780	122 51.081	10:30	HSEA	1	400/160	RE,LO,DI	PC	1
19-Sep-11	08:35	11:45	47 40.4280	122 50.838	10:36	HSEA	1	125/148	RE,LO,DI	PC	1
19-Sep-11	08:35	11:45	47 40.2180	122 50.757	10:38	HSEA	2	100/275	SW,LO	PC	1
19-Sep-11	08:35	11:45	47 40.0320	122 50.691	10:40	HSEA	1	50/050	SW,DI	PC	1
19-Sep-11	08:35	11:45	47 39.9050	122 50.657	10:41	HSEA	1	115/242	SW,LO	PC	0
19-Sep-11	08:35	11:45	47 39.5630	122 50.604	10:44	HSEA	1	500/140	SW,DI	PC	0
19-Sep-11	08:35	11:45	47 39.4100	122 50.566	10:46	HSEA	1	180/125	TR,DI	PC	0
19-Sep-11	08:35	11:45	47 39.3010	122 50.347	10:47	HSEA	1	110/150	SW,LO,DI	PC	0
19-Sep-11	08:35	11:45	47 39.2320	122 49.457	10:54	HSEA	1	75/050	SW,DI	PC	0
19-Sep-11	08:35	11:45	47 39.2890	122 48.805	10:58	HSEA	1	500/093	SI	PC	0
19-Sep-11	08:35	11:45	47 40.2880	122 46.111	11:16	HSEA	1	100/128	DI	PC	0
19-Sep-11	08:35	11:45	47 41.0950	122 44.931	11:27	HSEA	1	20/270	LO,SI	PC	0
19-Sep-11	08:35	11:45	47 41.2590	122 44.91	11:28	HSEA	1	125/270	LO,SI	PC	0
19-Sep-11	08:35	11:45	47 41.3490	122 44.897	11:29	HSEA	1	75/335	LO,DI	PC	0
20-Sep-11	08:20	11:48	47 41.3590	122 46.458	08:27	HSEA	1	110/208	LO,SI	S	1
20-Sep-11	08:20	11:48	47 40.9090	122 48.344	08:39	HSEA	1	500/240	RE,SI	S	1
20-Sep-11	08:20	11:48	47 40.8480	122 48.539	08:40	CASL	1	200/180	DI	S	1
20-Sep-11	08:20	11:48	47 40.8290	122 48.619	08:41	HSEA	1	60/295	SW,SI	S	1
20-Sep-11	08:20	11:48	47 40.9430	122 49.041	08:43	HSEA	1	250/280	LO,DI	S	1
20-Sep-11	08:20	11:48	47 41.2130	122 49.725	08:48	HSEA	1	300/291	SI	S	1
20-Sep-11	08:20	11:48	47 41.4010	122 50.086	08:50	HSEA	1	220/358	RE,SI	S	1
20-Sep-11	08:20	11:48	47 41.4630	122 50.142	08:51	HSEA	1	150/330	LO,SI	S	1
20-Sep-11	08:20	11:48	47 41.5600	122 50.142	08:52	HSEA	1	250/255	SI	S	1
20-Sep-11	08:20	11:48	47 41.6270	122 50.131	08:52	HSEA	1	250/255	SW,SI	S	1
20-Sep-11	08:20	11:48	47 41.8430	122 50.089	08:54	HSEA	1	100/040	RE	S	1
20-Sep-11	08:20	11:48	47 42.0650	122 49.987	08:56	HSEA	2	300/015	LO,SI	S	1
20-Sep-11	08:20	11:48	47 42.1670	122 49.847	08:58	HSEA	1	75/310	RE	S	1
20-Sep-11	08:20	11:48	47 42.2620	122 49.78	08:58	HSEA	2	350/012	LO,SI	S	1

Date:	Time Observation Initiated:	Time Observation Completed:	Latitude	Longitude	Sighting Time	Species	# of Anim(s)	Dist./Dir. to Ani(s)	Behavior Type	Weather Conditions	Beaufort
20-Sep-11	08:20	11:48	47 42.4400	122 49.694	09:00	HSEA	1	150/013	LO,SW,SI	S	1
20-Sep-11	08:20	11:48	47 42.5720	122 49.643	09:02	HSEA	1	270/345	SW,SI	S	1
20-Sep-11	08:20	11:48	47 42.6410	122 49.615	09:02	HSEA	1	200/350	LO,DI	S	1
20-Sep-11	08:20	11:48	47 42.6910	122 49.585	09:03	HSEA	1	150/015	SW,LO,SI	S	1
20-Sep-11	08:20	11:48	47 42.7660	122 49.478	09:04	HSEA	5	100/303	SW,DI	S	1
20-Sep-11	08:20	11:48	47 42.8550	122 49.312	09:05	HSEA	1	350/344	SW,SI	S	1
20-Sep-11	08:20	11:48	47 43.0990	122 48.988	09:08	HSEA	1	310/330	RE,SI	S	1
20-Sep-11	08:20	11:48	47 44.1380	122 48.929	09:17	HSEA	1	400/340	LO,RE,DI	S	1
20-Sep-11	08:20	11:48	47 44.2010	122 48.923	09:17	HSEA	1	350/347	TR,LO,DI	S	1
20-Sep-11	08:20	11:48	47 44.2740	122 48.917	09:20	HSEA	1	350/350	SW,SI	S	1
20-Sep-11	08:20	11:48	47 44.4990	122 48.902	09:20	HSEA	2	500/346	SI,,RE,SI	S	1
20-Sep-11	08:20	11:48	47 44.7570	122 48.88	09:22	HSEA	1	120/090	TR	S	1
20-Sep-11	08:20	11:48	47 44.0270	122 48.84	09:24	HSEA	2	175/040	SI	S	1
20-Sep-11	08:20	11:48	47 45.4450	122 48.651	09:28	HSEA	1	55/015	LO,SI	S	1
20-Sep-11	08:20	11:48	47 45.7030	122 48.509	09:31	HSEA	1	75/325	TR	S	1
20-Sep-11	08:20	11:48	47 45.9970	122 48.279	09:33	HSEA	1	275/020	SW,DI	S	1
20-Sep-11	08:20	11:48	47 46.1030	122 48.188	09:34	HSEA	1	60/065	SW,LO,SI	S	1
20-Sep-11	08:20	11:48	47 47.1950	122 47.768	09:45	HSEA	1	75/280	RE	S	1
20-Sep-11	08:20	11:48	47 47.2640	122 47.745	09:45	HSEA	1	280/035	SW,SI	S	1
20-Sep-11	08:20	11:48	47 47.3090	122 47.73	09:46	HPOR	2	160/055	TR	S	1
20-Sep-11	08:20	11:48	47 47.6220	122 47.64	09:48	HSEA	1	250/340	DI	S	1
20-Sep-11	08:20	11:48	47 47.6700	122 47.631	09:49	HSEA	1	280/050	RE	S	1
20-Sep-11	08:20	11:48	47 47.6970	122 47.624	09:50	HSEA	2	50/280	LO,DI	S	1
20-Sep-11	08:20	11:48	47 47.8670	122 47.628	09:51	HSEA	1	70/080	SW	S	1
20-Sep-11	08:20	11:48	47 48.3470	122 47.752	09:55	HSEA	1	65/145	LO,SI	S	1
20-Sep-11	08:20	11:48	47 48.8330	122 48.327	10:00	HSEA	1	280/344	RE	S	1
20-Sep-11	08:20	11:48	47 46.1380	122 49.127	10:29	HSEA	1	250/207	RE	S	1
20-Sep-11	08:20	11:48	47 44.8790	122 50.549	10:43	HSEA	1	50/227	RE	S	2
20-Sep-11	08:20	11:48	47 44.7060	122 50.655	10:44	HSEA	1	50/220	LO,SI	S	2
20-Sep-11	08:20	11:48	47 44.4790	122 50.807	10:46	HSEA	4	500/265	HO,LO	S	2
20-Sep-11	08:20	11:48	47 44.4260	122 50.841	10:47	HSEA	1	75/270	RE	S	2
20-Sep-11	08:20	11:48	47 44.3230	122 50.907	10:48	HSEA	1	150/252	LO,SI	S	2
20-Sep-11	08:20	11:48	47 44.1270	122 51.034	10:50	HSEA	1	180/273	LO,SW	S	2
20-Sep-11	08:20	11:48	47 44.0720	122 51.071	10:50	HSEA	4	400/270	RE	S	2
20-Sep-11	08:20	11:48	47 43.9890	122 51.125	10:51	HSEA	1	225/214	RE,LO	S	2

Date:	Time Observation Initiated:	Time Observation Completed:	Latitude	Longitude	Sighting Time	Species	# of Anim(s)	Dist./Dir. to Ani(s)	Behavior Type	Weather Conditions	Beaufort
20-Sep-11	08:20	11:48	47 43.6780	122 51.345	10:54	HSEA	1	150/163	SI	S	2
20-Sep-11	08:20	11:48	47 42.7480	122 51.763	11:02	HSEA	1	200/190	RE,DI	S	1
20-Sep-11	08:20	11:48	47 42.6810	122 51.777	11:03	HSEA	3	475/215	LO,SI	S	1
20-Sep-11	08:20	11:48	47 42.5470	122 51.806	11:04	HSEA	2	480/222	SW,TR,DI	S	1
20-Sep-11	08:20	11:48	47 42.4850	122 51.821	11:04	HSEA	1	100/168	RE	S	1
20-Sep-11	08:20	11:48	47 42.3220	122 51.856	11:05	HSEA	2	200/120	TR,DI	S	1
20-Sep-11	08:20	11:48	47 41.9090	122 51.745	11:09	HSEA	1	500/088	SW,DI	S	1
20-Sep-11	08:20	11:48	47 41.7790	122 51.601	11:11	HSEA	1	522/125	SW,SI	S	1
20-Sep-11	08:20	11:48	47 41.5900	122 51.366	11:13	HSEA	1	500/120	RE	S	1
20-Sep-11	08:20	11:48	47 41.5180	122 51.274	11:13	HSEA	1	500/143	TR,DI	S	1
20-Sep-11	08:20	11:48	47 41.4040	122 51.13	11:15	HSEA	2	550/177	RE	S	1
20-Sep-11	08:20	11:48	47 41.3270	122 51.026	11:16	HSEA	1	220/198	TR	S	1
20-Sep-11	08:20	11:48	47 41.2750	122 50.937	11:16	HSEA	1	600/087	TR	S	1
20-Sep-11	08:20	11:48	47 41.2360	122 50.884	11:17	HSEA	1	50/160	RE	S	1
20-Sep-11	08:20	11:48	47 41.1560	122 50.759	11:18	HSEA	1	800/179	RE	S	1
20-Sep-11	08:20	11:48	47 41.0820	122 50.641	11:19	HSEA	1	175/192	RE	S	1
20-Sep-11	08:20	11:48	47 41.0030	122 50.508	11:20	HSEA	1	800/200	TR	S	1
20-Sep-11	08:20	11:48	47 41.0830	122 46.626	11:43	HSEA	1	200/014	LO,SI	S	1
20-Sep-11	08:20	11:48	47 41.3200	122 46.157	11:46	HPOR	2	275/080	MI	S	1
27-Sep-11	08:45	12:00	47 40.9380	122 48.183	09:00	HSEA	1	100/198	LO,SI	S	2
27-Sep-11	08:45	12:00	47 46.4360	122 50.017	10:39	HSEA	1	75/240	LO,SI	S	3
27-Sep-11	08:45	12:00	47 44.2280	122 50.892	10:59	HSEA	10	300/266	HO	S	4
27-Sep-11	08:45	12:00	47 43.7800	122 51.188	11:04	HSEA	1	2/148	LO,SI	S	4
27-Sep-11	08:45	12:00	47 41.1330	122 50.331	11:30	HSEA	1	16711	LO,SI	S	4
28-Sep-11	08:58	12:25	47 41.5690	122 46.174	08:59	HSEA	1	150/203	LO,SI	F	0
28-Sep-11	08:58	12:25	47 40.9910	122 47.815	09:12	HSEA	1	125/238	TR,SI	PC,F	1
28-Sep-11	08:58	12:25	47 40.9160	122 48.241	09:15	CASL	1	400/198	RE,DI	PC	1
28-Sep-11	08:58	12:25	47 40.8220	122 48.615	09:18	HSEA	1	200/290	LO,SI	PC	1
28-Sep-11	08:58	12:25	47 40.8840	122 48.961	09:20	HSEA	1	450/186	LO,DI	PC	1
28-Sep-11	08:58	12:25	47 40.9900	122 49.345	09:23	HSEA	1	300/261	LO,DI	PC	1
28-Sep-11	08:58	12:25	47 41.0090	122 49.392	09:23	HPOR	4	300/247	TR,SI	PC	1
28-Sep-11	08:58	12:25	47 41.2900	122 50.042	09:28	HSEA	1	200/45	LO,SI	PC	2
28-Sep-11	08:58	12:25	47 42.8410	122 49.632	09:46	HSEA	1	100/105	LO,SI	PC	2+
28-Sep-11	08:58	12:25	47 45.9310	122 48.363	10:15	HSEA	1	100/267	LO,SI	PC	2+
28-Sep-11	08:58	12:25	47 45.8790	122 50.588	11:07	HSEA	2	200/206	LO,SI,DI	PC	3

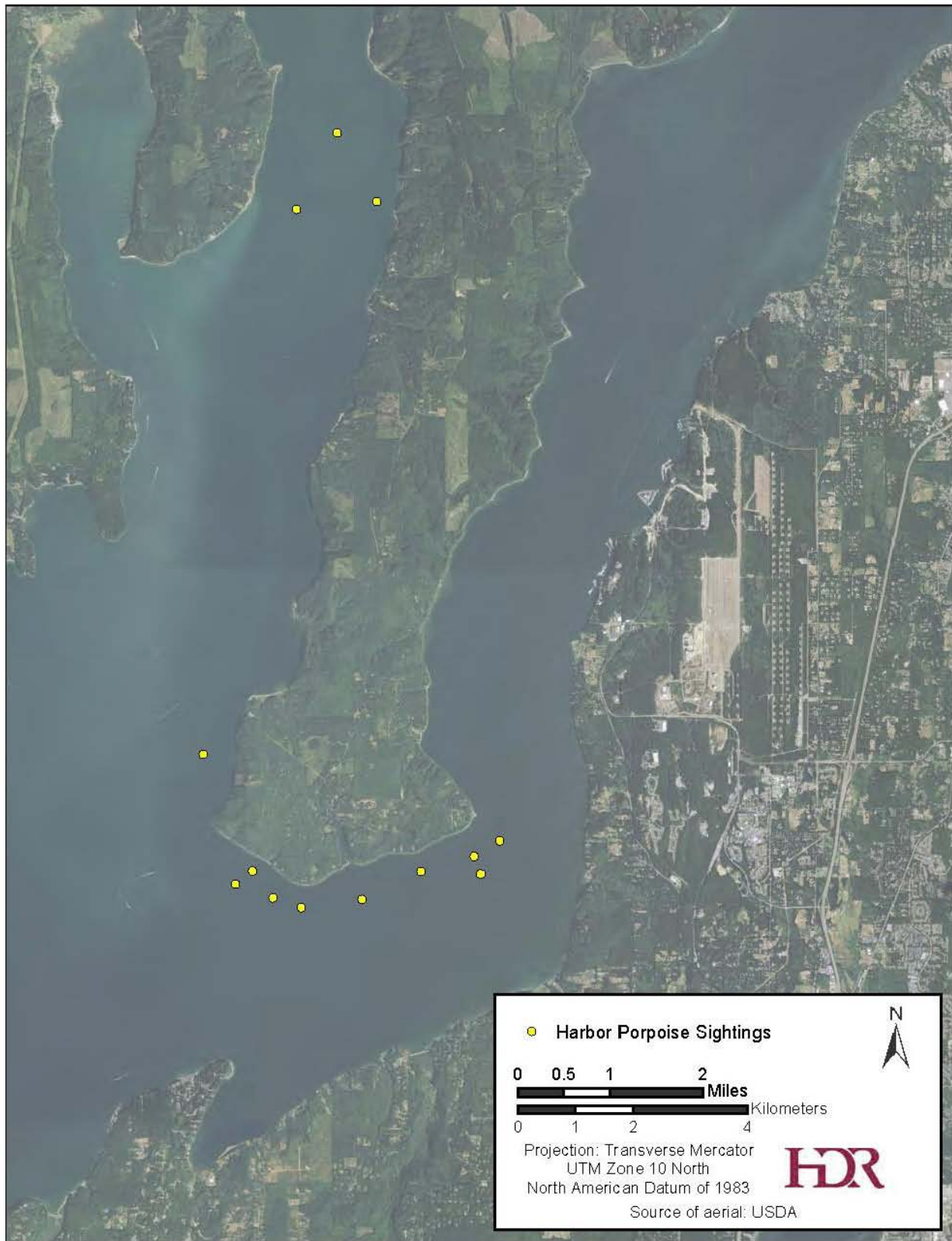
Date:	Time Observation Initiated:	Time Observation Completed:	Latitude	Longitude	Sighting Time	Species	# of Anim(s)	Dist./Dir. to Ani(s)	Behavior Type	Weather Conditions	Beaufort
28-Sep-11	08:58	12:25	47 45.1190	122 50.834	11:13	HSEA	1	200/182	LO,SI	PC	3
28-Sep-11	08:58	12:25	47 44.9740	122 50.868	11:14	HSEA	1	300/243	LO,SI	PC	3
28-Sep-11	08:58	12:25	47 44.7260	122 50.922	11:16	HSEA	2	300/250	RE	PC	3
28-Sep-11	08:58	12:25	47 44.3930	122 50.992	11:19	HSEA	29	150/250	RE	PC	3
28-Sep-11	08:58	12:25	47 40.6080	122 49.464	12:02	HSEA	1	200/315	LO,DI	PC	4
28-Sep-11	08:58	12:25	47 40.6120	122 49.104	12:03	HSEA	1	100/60	LO,SI	PC	4
28-Sep-11	08:58	12:25	47 41.0010	122 47.342	12:14	HSEA	1	50/108	LO,SI	PC	4
28-Sep-11	08:58	12:25	47 41.1040	122 46.951	12:17	HSEA	1	100/308	LO,SI	PC	2
28-Sep-11	08:58	12:25	47 41.1280	122 46.852	12:18	HSEA	1	125/325	SI	PC	2
28-Sep-11	08:58	12:25	47 41.2490	122 46.463	12:21	HSEA	1	150/330	SI	PC	2
24-Oct-11	10:05	12:55	47 47.3920	122 46.312	10:07	HSEA	3	200/50	LO,DI	PC	2
24-Oct-11	10:05	12:55	47 40.9510	122 49.057	10:28	HSEA	1	100/256	LO,DI	PC	2
24-Oct-11	10:05	12:55	47 40.0800	122 49.407	10:30	HSEA	1	250/297	SW(s),DI	PC	2
24-Oct-11	10:05	12:55	47 42.1590	122 49.911	10:42	HSEA	1	75/30	SW(e),DI	PC	2
24-Oct-11	10:05	12:55	47 45.8760	122 48.683	11:09	HSEA	1	50/357	DI	PC	2
24-Oct-11	10:05	12:55	47 48.2020	122 47.961	11:26	HSEA	2	250/124	LO,DI	PC	2
24-Oct-11	10:05	12:55	47 40.9490	122 49.291	12:33	HSEA	1	25/110	LO,SI	PC	2
24-Oct-11	10:05	12:55	47 41.5330	122 46.187	12:52	HSEA	1	50/47	LO,SI	PC	1
25-Oct-11	09:45	13:00	47 41.5830	122 46.17	09:45	HSEA	1	80m/190	SW(200), SI	PC	1
25-Oct-11	09:45	13:00	47 41.4380	122 46.294	09:47	HSEA	1	60m/310	SW(015), SI	PC	1
25-Oct-11	09:45	13:00	47 41.2110	122 46.912	09:54	HSEA	1	90m/235	SW(035), LO,SI	PC	1
25-Oct-11	09:45	13:00	47 40.9660	122 47.995	10:02	HSEA	1	125m/124	SW,DI	PC	1
25-Oct-11	09:45	13:00	47 40.9090	122 48.212	10:04	HSEA	1	150m/248	DI	PC	1
25-Oct-11	09:45	13:00	47 40.8500	122 48.676	10:05	HSEA	1	250m/263	RE,SW(360)	PC	1
25-Oct-11	09:45	13:00	47 40.9180	122 49.182	10:12	HSEA	1	200m/273	SW(095),SI	PC	1
25-Oct-11	09:45	13:00	47 41.0420	122 49.37	10:13	HSEA	2	300m/186	MI	PC	1
25-Oct-11	09:45	13:00	47 41.1830	122 49.673	10:17	CASL	3	200m/255	MI	PC	0
25-Oct-11	09:45	13:00	47 41.1830	122 49.673	10:17	HSEA	13	200m/255	MI	PC	1
25-Oct-11	09:45	13:00	47 41.7480	122 49.965	10:23	HSEA	1	230m/363	SW,SI	PC	0
25-Oct-11	09:45	13:00	47 41.7480	122 49.965	10:23	HSEA	1	60m/050	SW,SI	PC	0
25-Oct-11	09:45	13:00	47 41.9940	122 49.836	10:26	HSEA	1	200m/282	SW	PC	0
25-Oct-11	09:45	13:00	47 41.9940	122 49.836	10:26	HSEA	2	300m/328	MI	PC	0



Date:	Time Observation Initiated:	Time Observation Completed:	Latitude	Longitude	Sighting Time	Species	# of Anim(s)	Dist./Dir. to Ani(s)	Behavior Type	Weather Conditions	Beaufort
25-Oct-11	09:45	13:00	47 42.2690	122 49.765	10:28	HSEA	8	200m/362	MI,SW,SI	PC	0
25-Oct-11	09:45	13:00	47 42.8240	122 49.318	10:34	HSEA	1	70m/012	SW,SI	PC	1
25-Oct-11	09:45	13:00	47 42.9590	122 49.043	10:35	HSEA	3	200m/061	SW	PC	1
25-Oct-11	09:45	13:00	47 43.8940	122 48.75	10:44	HSEA	1	400m/253	SW,DI	PC	0
25-Oct-11	09:45	13:00	47 44.4210	122 48.785	10:48	HSEA	2	320m/320	SW,DI	PC	0
25-Oct-11	09:45	13:00	47 45.0190	122 48.567	10:53	HSEA	1	175m/335	SW,DI	PC	1
25-Oct-11	09:45	13:00	47 48.4350	122 47.856	11:24	HSEA	2	300m/246	MI,DI	PC	1
25-Oct-11	09:45	13:00	47 48.3420	122 48.82	11:30	CASL	1	200m/160	SW,DI	PC	1
25-Oct-11	09:45	13:00	47 47.9350	122 48.988	11:32	HSEA	1	50m/086	SW,DI	PC	1
25-Oct-11	09:45	13:00	47 47.2290	122 49.283	11:39	HSEA	1	75m/183	SW,DI	PC	1
25-Oct-11	09:45	13:00	47 47.2290	122 49.283	11:39	HSEA	1	150m/175	SW,DI	PC	0
25-Oct-11	09:45	13:00	47 45.2180	122 50.854	11:50	HSEA	1	200m/186	SW,DI	PC	0
25-Oct-11	09:45	13:00	47 44.4080	122 51.05	11:56	HSEA	13	50m/220	SW,MI	PC	1
25-Oct-11	09:45	13:00	47 43.5620	122 51.381	12:03	HSEA	1	100m/134	RE,DI	PC	1
25-Oct-11	09:45	13:00	47 41.4000	122 50.819	12:12	HSEA	1	60m/131	SW,DI	PC	1
25-Oct-11	09:45	13:00	47 41.6240	122 50.61	12:14	HSEA	1	75m/190	SW,DI	PC	1
26-Oct-11	13:40	13:57	47 41.1360	122 47.225	13:54	HSEA	1	10/317	LO(ne),SI	pc	4

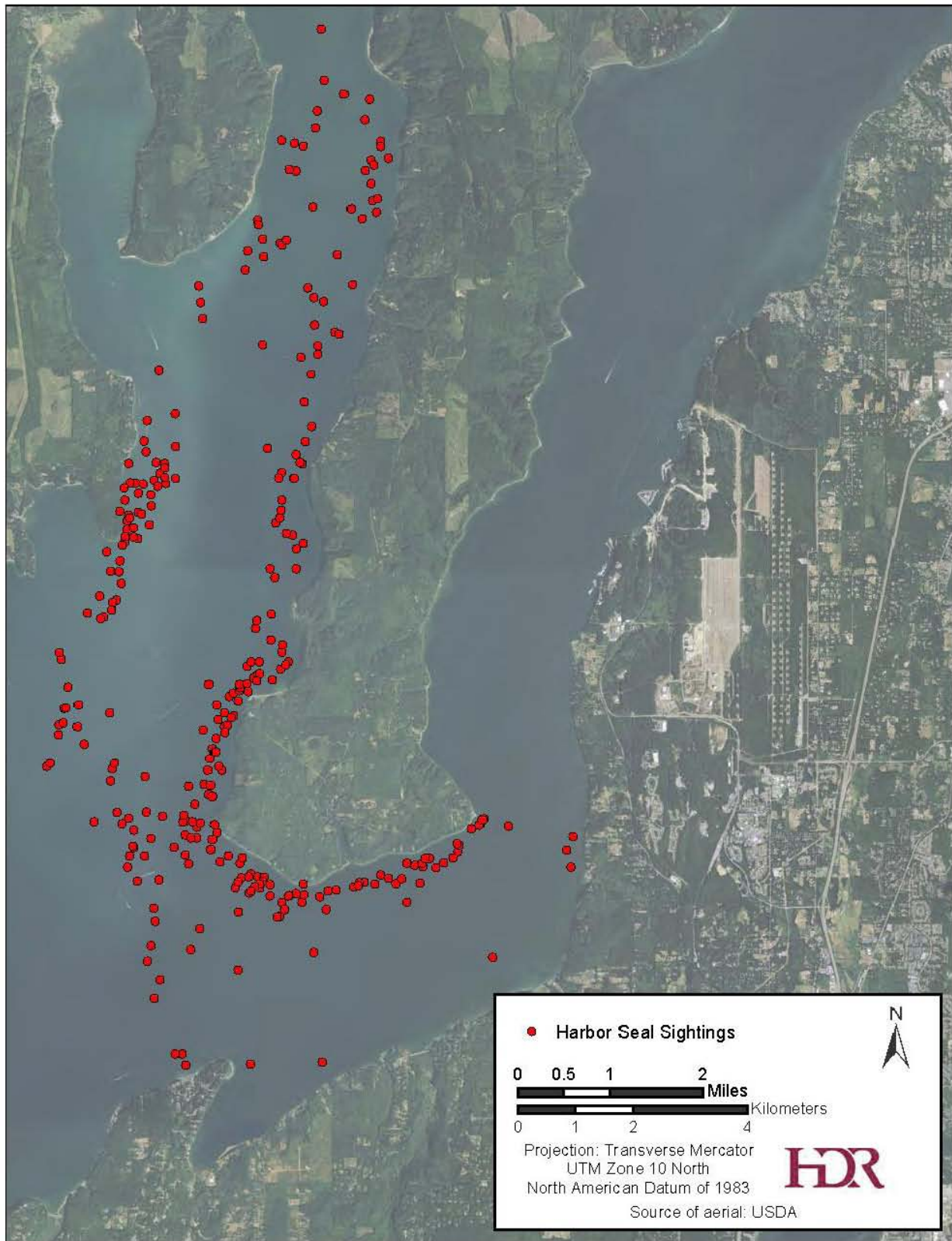


**Figure B-11. All California sea lion sightings during Dabob Bay Surveys. Points may represent more than one individual.**

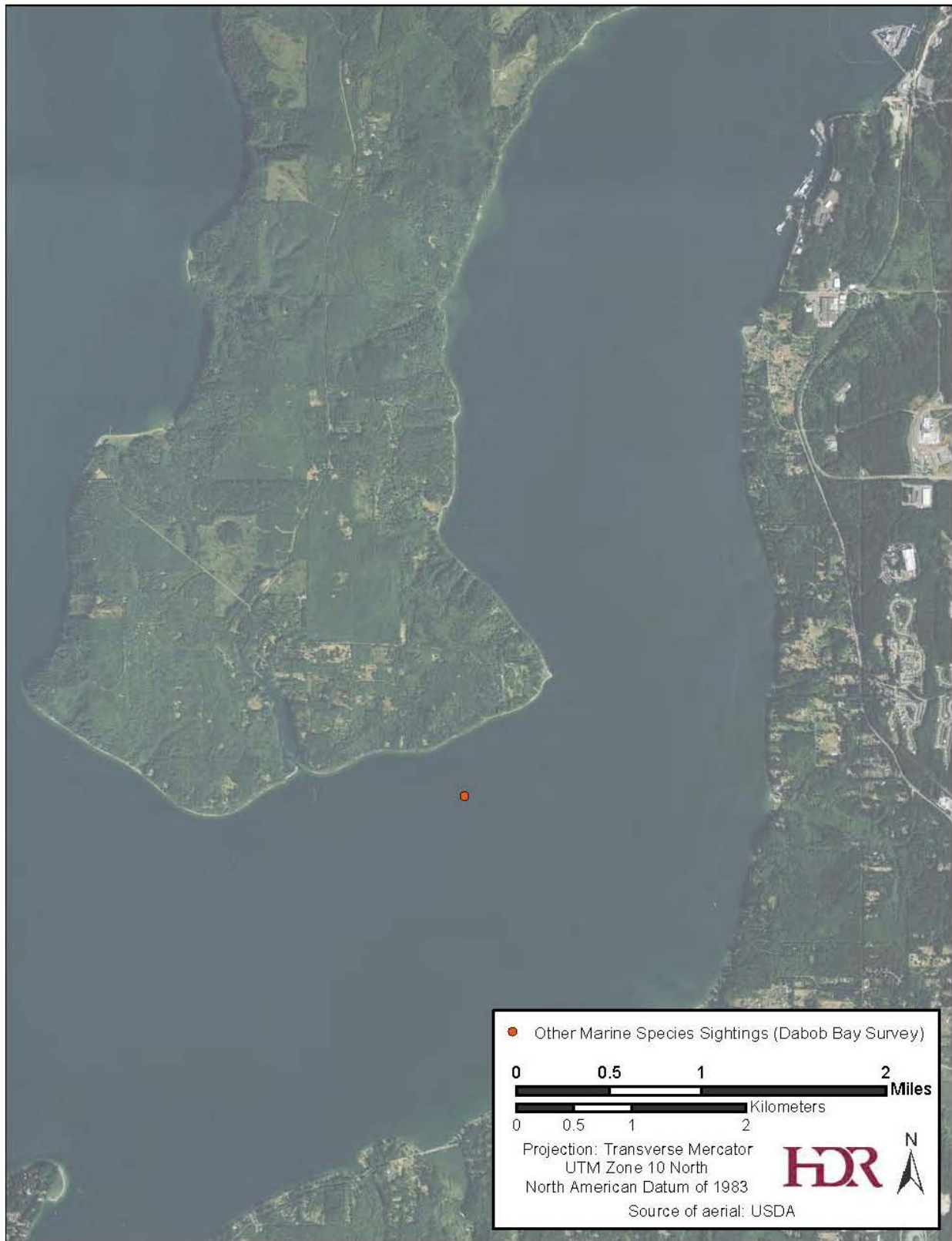


**Figure B-12. All harbor porpoise sightings during Dabob Bay Surveys. Points may represent more than one individual.**



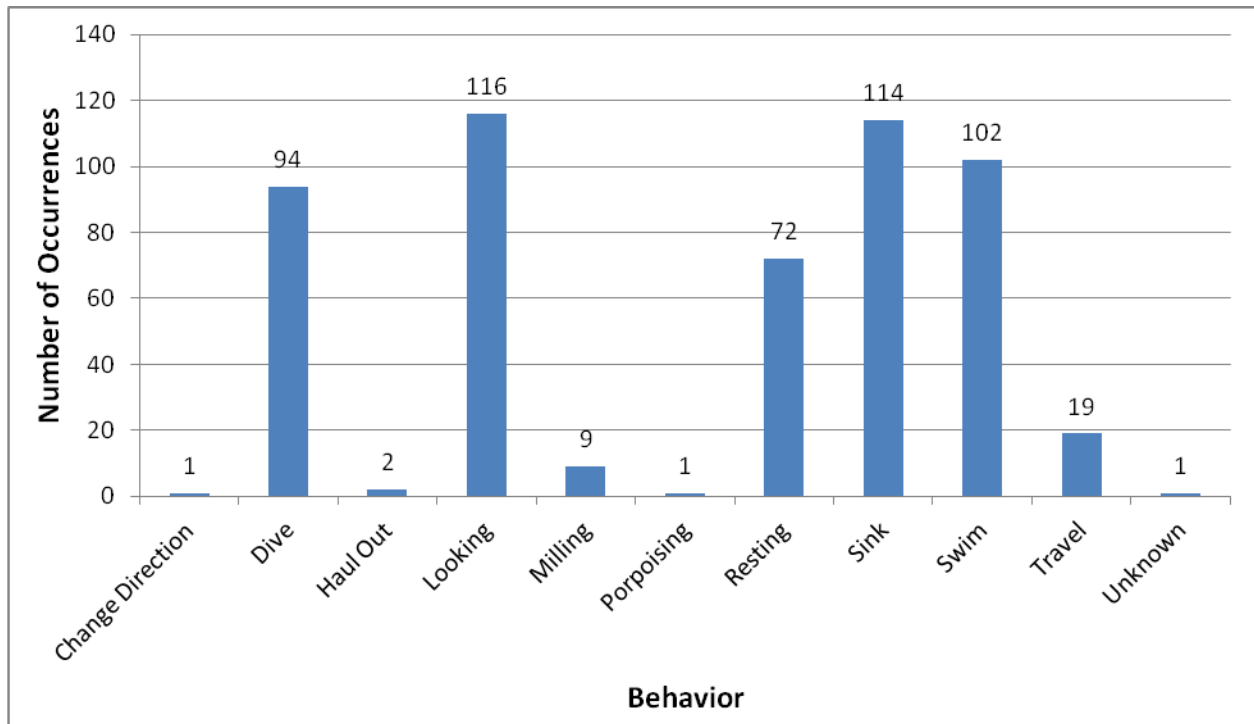


**Figure B-13. All harbor seal sightings during Dabob Bay Surveys. Points may represent more than one individual.**

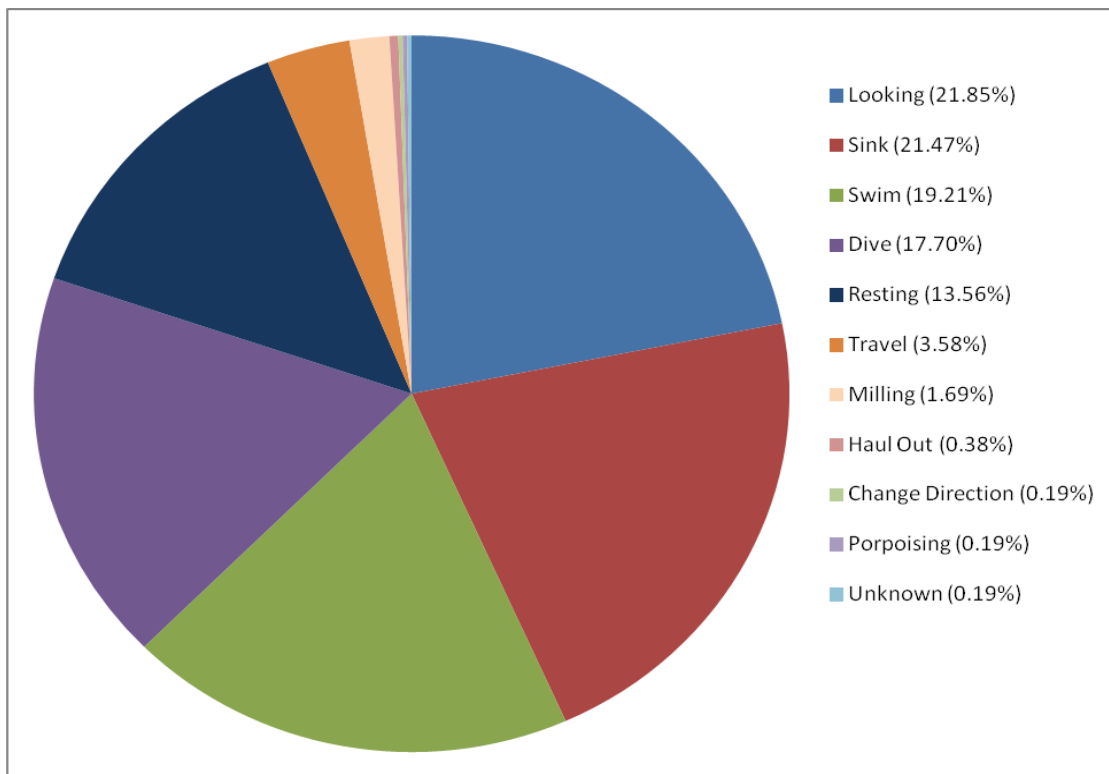


**Figure B-14. Other Marine Species (Unidentified Pinniped) Sighting During Dabob Bay Surveys**





**Figure B-15. Number of Behaviors Observed During Dabob Bay Surveys**



**Figure B-16. Percentage of Behaviors Observed During Dabob Bay Surveys**

***THIS PAGE INTENTIONALLY LEFT BLANK***

## APPENDIX C

### Environmental, Oceanographic, and Sighting Conditions

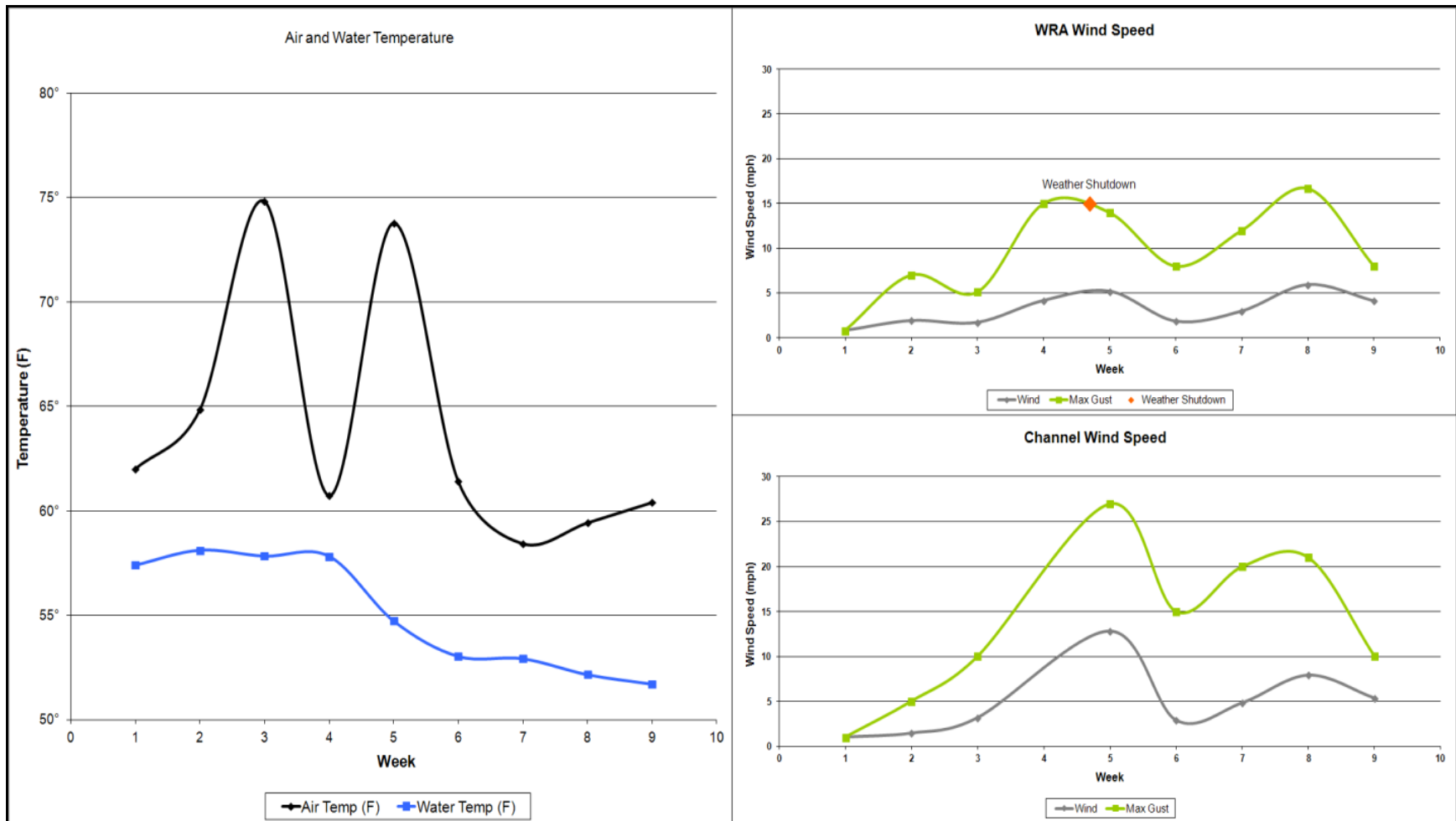


Figure C-1. Air and Water Temperature and Wind Speed

Table C-1. Environmental Data from Boats Inside and Outside the WRA

Date	Time	Boat	Wind Speed (mph)	Wind Direction	Humidity	Air Temp (F)	Water Temp (F)	Water Depth (ft)	Wave Height (ft)	Weather conditions	Background Sound Level Notes
<b>Boats Inside the WRA</b>											
8/26/2011	8:17	Shocker	--	--	--	--	57.3	90	0	S	Boats, Siren
8/26/2011	9:06	Shocker	--	--	--	--	57.3	136	0	S	Boats, Siren
8/26/2011	9:30	Swift	1	NNE	61.2	62	57	90	0	C	Tug, barge, engine on
8/29/2011	8:58	Shocker	--	--	--	--	56.3	74.3	0	C	Boats
8/29/2011	9:05	Streak	0	--	76.5	66.1	55.2	43.3	0	C/F	
8/29/2011	10:00	Shocker	--	--	--	--	56.3	2.3	0	C	Boats, Crane
8/29/2011	10:06	Streak	0	--	72.1	65.5	55.2	43.3	0	C/F	
8/29/2011	11:07	Shocker	--	--	--	--	56.3	4.6	0	C	Boats
8/29/2011	11:12	Streak	4	NW	73.5	64.4	58.2	67.6	2	C/F	
8/29/2011	11:45	Swift	2	SW	--	58	57	52	0	OC	
8/29/2011	12:11	Shocker	--	--	--	--	56.3	2.2	0	C	Boats
8/29/2011	12:19	Streak	3	--	69.7	67.6	58.2	44.5	0.5	C/F	
8/29/2011	13:08	Shocker	--	--	--	--	56.3	14.4	0	C	Boats, Generator
8/29/2011	14:03	Shocker	--	--	--	--	56.3	27.2	0	C	Boats
8/29/2011	14:03	Streak	1	--	66.2	70.8	60	143	0	C/F	metal work in tug
8/29/2011	15:04	Shocker	--	--	--	--	56.3	6.2	0	C	Generator, Crane, Boats
8/30/2011	8:42	Shocker	--	--	--	--	59.3	7.3	0	C	Generator, Boats
8/30/2011	9:00	Streak	1	--	62.9	63.9	63.5	73	0	OC	
8/30/2011	9:32	Streak	1	--	62.2	72.2	57	142	0.5	OC	
8/30/2011	10:37	Streak	3	--	66.9	63.3	57	--	0	OC	
8/30/2011	11:04	Shocker	--	--	--	--	59.3	2.2	0	C	Boats
8/30/2011	12:27	Shocker	--	--	--	--	59.3	2.2	0	C	Boats
8/30/2011	13:11	Streak	0	--	62.2	71.3	57.3	88	0	OC	
8/30/2011	13:22	Streak	1	--	61.8	71.2	--	50	0	OC	
8/30/2011	13:28	Shocker	--	--	--	--	59.3	24.5	0	C	Boats, Generator
8/30/2011	14:11	Streak	1	--	64.1	62.9	57	142	0	OC	
8/30/2011	15:02	Shocker	--	--	--	--	59.3	31.1	0	C	Boats, Generator
8/31/2011	7:35	Shocker	--	--	--	--	57.4	21.7	0	C	Boats
8/31/2011	7:55	Streak	2	NW	75.5	56.6	60	92	0.5	OC	
8/31/2011	7:58	Swift	2	SW	--	56	57.4	47.4	0	C	Crane engine
8/31/2011	9:20	Swift	1	SW	--	57	57.4	70.4	0	C	soft start vibe
8/31/2011	9:45	Shocker	--	--	--	--	57.4	3.2	0	PC	Generator
8/31/2011	10:42	Streak	1	SW	61	67.5	56	19	0	OC	

Date	Time	Boat	Wind Speed (mph)	Wind Direction	Humidity	Air Temp (F)	Water Temp (F)	Water Depth (ft)	Wave Height (ft)	Weather conditions	Background Sound Level Notes
<b>Boats Inside the WRA (continued)</b>											
8/31/2011	11:28	Streak	1	--	57.6	69.8	57	197	0	PC	
8/31/2011	11:30	Swift	--	SW	--	58	57.4	70	0	C	
8/31/2011	11:41	Shocker	--	--	--	--	57.4	2.9	0	PC	Generator
8/31/2011	12:46	Shocker	--	--	--	--	57.4	29.6	0	S	Boats
8/31/2011	13:05	Swift	4	NNW	--	58	57.4	70	0	C	
8/31/2011	13:27	Streak	3	N	58.1	55.4	56	105	1	PC	
8/31/2011	14:00	Swift	4	NNW	--	62	57.4	75	0	C	
8/31/2011	14:01	Streak	7	N	77.3	60.3	57	132	3	PC	
8/31/2011	14:34	Shocker	--	--	--	--	57.4	4.7	0	PC	Boats
8/31/2011	15:00	Swift	0	NNW	--	52	57.4	75	0	F	
9/1/2011	7:53	Shocker	--	--	--	--	59.7	26.5	0	F	Boats
9/1/2011	7:53	Swift	0	NNW	--	54	57.4	75	0.25	S	
9/1/2011	8:24	Streak	1	--	84	56	59	16	0	F/S	
9/1/2011	8:58	Streak	1	NW	80.3	59	57	142	0	F/S	
9/1/2011	11:08	Shocker	--	--	--	--	59.7	78.2	0	S	Boats
9/1/2011	11:15	Swift	3	SW	--	--	--	--	--	--	
9/1/2011	11:54	Shocker	--	--	--	--	59.7	3.3	0	PC	Boats
9/1/2011	14:44	Shocker	--	--	--	--	59.7	32.1	0	S	Boats
9/1/2011	15:04	Streak	5	N	49.7	67.6	59	18	0.5	S	Boat idling
9/1/2011	15:19	Streak	3	N	70	66.2	61	139	1	S	
9/1/2011	16:23	Streak	2	N	53.2	74.7	62	16	0.5	S	
9/8/2011	8:35	Shocker	--	--	--	--	56	14.4	0	S	Boats
9/8/2011	9:35	Shocker	--	--	--	--	56	20.9	0	S	Boats
9/8/2011	11:00	Streak	--	N	52	75	56	105	--	--	--
9/8/2011	11:10	Shocker	--	--	--	--	56	4.8	0	S	Boats
9/8/2011	12:35	Streak	0	--	55.6	76.9	56	93	0	--	--
9/8/2011	12:48	Shocker	--	--	--	--	56.8	7.2	0	S	Boats
9/8/2011	13:15	Streak	2	W	48.8	75.9	57	50	--	--	--
9/8/2011	13:25	Shocker	--	--	--	--	56.8	9.4	0	S	Trucks, Boats
9/8/2011	13:50	Streak	5	--	--	68.2	57	51	--	--	--
9/8/2011	15:35	Streak	4	--	52.5	72.4	57	59	--	--	--
9/8/2011	15:45	Shocker	--	--	--	--	56.8	11.2	0	S	Boats
9/10/2011	8:55	Swift	0	--	Fog	58	58	85	0	F/S	--
9/10/2011	9:50	Swift	1	N	--	79	58	85	0	S	--
9/10/2011	10:13	Shocker	--	--	--	--	58.2	23.5	0	S	Boats, Generator



Date	Time	Boat	Wind Speed (mph)	Wind Direction	Humidity	Air Temp (F)	Water Temp (F)	Water Depth (ft)	Wave Height (ft)	Weather conditions	Background Sound Level Notes
<b>Boats Inside the WRA (continued)</b>											
9/10/2011	10:48	Swift	1	N	--	79	58	Variable	0	S	TP-3 Batter start
9/10/2011	13:41	Shocker	--	--	--	--	58.2	97	0	S	Boats
9/10/2011	16:00	Swift	1	N	--	75	58	Variable	0	S	--
9/15/2011	10:14	Shocker	--	--	--	--	58.4	19.8	0	PC	Boats
9/15/2011	10:36	Streak	1	--	60.7	65.9	62	40	0	OC	Boat idling
9/15/2011	11:18	Shocker	--	--	--	--	58.4	25.6	0	OC	Boats
9/15/2011	11:38	Streak	1	N	75.3	53.3	56.1	48.5	0	OC	
9/15/2011	12:30	Streak	0	--	75.3	56.5	56.3	48.5	0	OC	
9/15/2011	13:01	Shocker	--	--	--	--	58.4	16.2	0	OC/C	Boats
9/15/2011	15:52	Streak	0	--	63.3	58.6	56.3	48.5	0	OC	
9/16/2011	8:30	Swift	0	--	56	56	58.4	Variable	0	PC	Manson Tug & Crane
9/16/2011	8:31	Shocker	0	NA	58	57.2	58.4	53.5	0	PC	Boats
9/16/2011	9:27	Swift	0	--	54	53.6	58.6	Variable	0	OC	Manson Tug, Welding
9/16/2011	9:30	Shocker	0	NA	77	58.4	58.4	25.6	0	PC	Boats
9/16/2011	10:14	Swift	0	--	55	56	57.7	Variable	0	PC	Crane, Manson Tug
9/16/2011	10:30	Shocker	0	NA	61	61.7	58.4	28.2	0	PC	Boats/Generators
9/16/2011	11:25	Swift	1	--	61	64	58.2	Variable	0	PC	--
9/16/2011	11:30	Shocker	0	NA	46	72.2	58.4	15.2	0	PC	Boats
9/16/2011	12:30	Shocker	0	NW	34	78.9	58.4	3.3	0	PC	Boats
9/16/2011	13:30	Shocker	0	W	33	74	58.4	3.3	0	PC	Boats
9/16/2011	14:30	Shocker	0	NA	51	63.8	58.4	5.7	0	OC	Boats
9/16/2011	14:39	Swift	0	--	59	61	60.2	Variable	0	OC	Tug Pulling, welding
9/16/2011	15:30	Shocker	0	NA	62	61.5	58.4	36.8	0	OC	Boats
9/16/2011	15:38	Swift	0	--	62	63	60.5	Variable	0	OC	Security Boat
9/16/2011	16:28	Swift	0	--	62	63	59.3	Variable	0	OC	Barge demobilization
9/16/2011	16:30	Shocker	0	NA	65	59.7	58.4	19.7	0	OC	Boats
9/16/2011	16:40	Swift	0	--	59	62	59.7	Variable	0	OC	--
9/17/2011	9:15	Shocker	15	SW	69	46.8	56.3	14.7	1	OC	Boats
9/17/2011	9:33	Shocker	11	SW	90	57.1	56.3	37.4	1	OC	Boats
9/17/2011	9:37	Swift	11	SW	56	56.6	56.1	65	1	OC	wind dropping
9/17/2011	9:45	Shocker	11	SW	79	58	56.3	36.3	1	OC	--
9/17/2011	9:50	Swift	10	SW	55.5	55.8	56	65	0.5-1	OC	wind dropping
9/17/2011	10:04	Swift	6	SW	55.5	56	56	Variable	1	OC	Vibratory hammer
9/17/2011	10:45	Shocker	5	SW	84	60.1	56.5	25.8	0	R	Boats
9/17/2011	11:25	Swift	7	SW	55.7	55.5	57	Variable	0	OC	Vibratory hammer

Date	Time	Boat	Wind Speed (mph)	Wind Direction	Humidity	Air Temp (F)	Water Temp (F)	Water Depth (ft)	Wave Height (ft)	Weather conditions	Background Sound Level Notes
<b>Boats Inside the WRA (continued)</b>											
9/17/2011	11:30	Shocker		SW	82	62	56.5	1.6	0	R	Boats
9/17/2011	12:24	Swift	7	SW	59.5	60	56	85	0	OC	Vibratory hammer
9/17/2011	12:30	Shocker	6	SW	77	59.8	56.5	22	0	OC	Generator
9/17/2011	13:30	Shocker	13	SW	70	65.3	56.5	77.1	1	OC	Boats
9/17/2011	14:10	Swift	10	SW	64.3	64.3	56.8	125	0.5	PC	14 mph gusts, vibratory
9/17/2011	14:30	Shocker	10	SW	60	67.5	56.5	20.2	1	PC	--
9/17/2011	14:56	Swift	9	SW	60.5	60.5	57.3	125	0.5	PC	No vibe, tug moving
9/17/2011	15:30	Shocker	7	SW	60	66.1	56.9	63.8	0	PC	Boats
9/17/2011	15:37	Swift	7	SW	61.5	62.6	57.9	125	0	PC	Boats
9/17/2011	16:30	Shocker	7	SW	62	64.5	56.9	67.9	0	PC	Boats
9/17/2011	16:31	Swift	3	SW	61.8	63.1	58.2	98	0	PC	Boats
9/21/2011	8:20	Shocker	0	--	--	59.2	55.2	Variable	0	OC	--
9/21/2011	9:41	Barge	0	--	79.8	63.9	--	--	0	OC	--
9/21/2011	10:54	Barge	4	SW	80	55.5	--	--	0.75	OC	Pulling up spuds, crane, engines
9/21/2011	12:21	Barge	1	SW	64.6	69.9	--	--	0.25	OC	Crane, engines
9/21/2011	13:23	Barge	3	SE	49.5	79.8	--	--	0.25	OC	Hammer generator, crane, other boats
9/21/2011	14:22	Barge	2	SW	29.5	79.3	--	--	0.25	OC, Warm	Hammer generator, crane, other boats
9/21/2011	15:26	Barge	4	SE	39.9	76.8	--	--	0.25	OC, Warm	Hammer generator, crane, other boats
9/21/2011	16:10	Barge	6	SE	33.3	77.6	--	--	0.25	OC, Warm	Crane
9/22/2011	8:24	Shocker	14	SW	81	66	55.5	Variable	0.5	OC	Boats
9/22/2011	9:30	Shocker	10	SW	79	67	56	36	0.25	OC	Boats, Vib. Hammer
9/22/2011	10:30	Shocker	--	--	76	69	56	Variable	0	OC	Boats
9/22/2011	14:50	Shocker	5	SW	74	70	55	Variable	0	PC	Boats
9/23/2011	8:10	Shocker	5	SW	74	69	55	Variable	0	PC	Boats
9/23/2011	9:10	Shocker	6	SW	70	72	55	32	0.5	PC	Boats
9/23/2011	10:10	Shocker	9	SW	70	72	56	Variable	0.5	PC	Boats
9/23/2011	11:10	Shocker	11	SW	66	75	46	56	0.1	PC	Boats, Crane, Generator
9/23/2011	12:10	Shocker	11	SW	67	75	48	56	0.1	PC	Boats, Crane, Generator
9/23/2011	13:10	Shocker	11	SW	65	74	56	56	0.5	PC	Boats, Crane, Generator
9/23/2011	14:10	Shocker	11	SW	66	76	56	34	0.5	S	Boats, Crane, Generator
9/23/2011	15:05	Shocker	6	SW	61	77	56	38	0.25	S	Boats, Crane, Generator
9/23/2011	16:16	Shocker	7	SW	59	76	56	35	0.25	S	Boats, Crane, Generator
9/24/2011	8:40	Shocker	4	SW	85	58	54	70	0	S	Boats
9/24/2011	9:40	Shocker	1	SW	78	64	54	5.6	0	S	Boats
9/24/2011	10:40	Shocker	1	SW	66	65	54	50	0	S	Boats

Date	Time	Boat	Wind Speed (mph)	Wind Direction	Humidity	Air Temp (F)	Water Temp (F)	Water Depth (ft)	Wave Height (ft)	Weather conditions	Background Sound Level Notes
<b>Boats Inside the WRA (continued)</b>											
9/24/2011	11:40	Shocker	2	SW	70	64	54	51	0	S	Boats
9/24/2011	12:40	Shocker	1	SW	50	80	54	53	0	PC	Boats
9/24/2011	13:40	Shocker	3	SW	55	77	54.5	54	0	PC	Boats
9/24/2011	14:40	Shocker	4	SW	42.5	79	54.5	49	0	PC	Boats, Crane
9/24/2011	15:40	Shocker	5	SW	41	78	54.5	51	0	OC	Boats, Crane
9/24/2011	16:40	Shocker	4	SW	38	77	54.5	50	0	OC	Barge only
9/26/2011	8:20	Shocker	4	SW	100	55	52	Variable	0	R	Boats
9/26/2011	10:00	Shocker	3	SW	100	54	53	35	0	R	Boats
9/26/2011	11:00	Shocker	4	SW	100	55	53	33	0	R	Boats
9/26/2011	11:53	Shocker	5	SW	100	61.3	52.9	5	0	R	Boats
9/28/2011	9:40	Shocker	1	--	70	63	51.7	Variable	0	S	2 cranes moving gear
9/28/2011	10:40	Shocker	1	--	65	64.2	51.7	Variable	0	S	1 crane moving gear
9/28/2011	11:38	Shocker	1	--	58	62.4	51.7	Variable	0	S	--
9/28/2011	11:54	Shocker	0	--	46	63.9	51.7	Variable	0	S	Tug moving
9/28/2011	14:20	Shocker	0	--	41	72.7	53.2	Variable	0	PC	crane lifting, tug moving
9/28/2011	15:33	Shocker	0	--	48	72.1	54.6	Variable	0	PC	crane lifting
9/28/2011	16:31	Shocker	0	--	46	64.6	55.5	Variable	0	PC	vibratory extraction
9/28/2011	17:15	Shocker	0	--	45	81	55.5	Variable	0	PC	--
9/30/2011	8:15	Shocker	0	--	86	52	52	Variable	0	PC	Boats
9/30/2011	9:15	Shocker	0	--	76	57	52	Variable	0	PC	Boats
9/30/2011	10:15	Shocker	0	--	68	63	52	46	0	PC	Boats
9/30/2011	11:15	Shocker	2	SW	72	63	52	45	0	PC	Boats
9/30/2011	12:15	Shocker	0	--	80	60	52	Variable	0	R	Boats
9/30/2011	13:15	Shocker	2	N	85	56	52	Variable	0	R	Boats
9/30/2011	14:15	Shocker	8	NE	70	65	52	Variable	0.25	PC	Boats
9/30/2011	15:15	Shocker	7	NE	73	60	52	48	0.25	PC	Boats
10/1/2011	8:15	Shocker	3	SW	84	52	53	Variable	0	C	Boats
10/1/2011	9:30	Shocker	2	SW	81	54	53	Variable	0	C	Boats
10/1/2011	10:30	Shocker	0	--	75	57	53	Variable	0	C	Boats
10/1/2011	11:30	Shocker	0	--	70	60	53	Variable	0	C	Boats
10/1/2011	12:30	Shocker	2	SW	70	58	53	Variable	0	C	Boats
10/1/2011	13:30	Shocker	2	SW	63	60	53	Variable	0	C	Boats
10/1/2011	14:30	Shocker	2	SW	70	60	53	Variable	0	MC	Boats
10/1/2011	15:30	Shocker	4	SW	80	57	53	Variable	0	C	Boats
10/3/2011	8:30	Shocker	2	SW	100	57	54	Variable	0	C	Boats

Date	Time	Boat	Wind Speed (mph)	Wind Direction	Humidity	Air Temp (F)	Water Temp (F)	Water Depth (ft)	Wave Height (ft)	Weather conditions	Background Sound Level Notes
<b>Boats Inside the WRA (continued)</b>											
10/3/2011	9:30	Shocker	4	SW	100	60	54	36	0	R	Boats
10/3/2011	10:30	Shocker	4	SW	95	61	54	Variable	0	LR	Boats
10/3/2011	11:30	Shocker	4	SW	76	63	54	Variable	0	C	Boats
10/3/2011	12:30	Shocker	4	SW	70	61	54	Variable	0.25	C	Boats, Generator
10/3/2011	13:30	Shocker	5	SW	71	61	54	40	0.25	C	Boats, Generator
10/3/2011	14:30	Shocker	7	SW	75	61	54	40	0.25	C	Boats, Generator
10/3/2011	15:30	Shocker	2	SW	72	63	54	Variable	0	C	Boats
10/3/2011	17:30	Shocker	3	SW	79	60	54	50	0	C	Boats, Generator
10/4/2011	8:00	Shocker	--	SW	100	54	53	Variable	0.5	PC	Boats
10/4/2011	8:30	Swift	12	SW	85.2	52.3	53.4	170	1	LR	Boats
10/4/2011	10:08	Swift	4	SW	95.3	55.5	53.4	170	0	OC	Boats
10/4/2011	11:09	Swift	6	SW	87.6	58.6	53.4	170	0.5	OC/LR	Boats
10/4/2011	12:11	Swift	8	SW	84.6	56.3	53.4	170	0	OC	Boats
10/4/2011	14:30	Swift	6	SW	88.3	58.2	53.4	70	0	PC	Boats
10/4/2011	16:07	Swift	4	SW	83.2	58.7	53.4	150	0	PC	Boats
10/5/2011	7:07	Swift	3	SW	87.4	51.4	52.7	170	0	PC	Boats
10/5/2011	8:31	Swift	3	SW	91.7	51	52.7	170	0	PC	Boats
10/5/2011	11:36	Swift	1	SW	92.5	54.8	53	200	0	OC	Boats
10/5/2011	12:40	Swift	1	SW	84.3	54.5	53	170	0	OC	Boats, generator
10/5/2011	14:38	Swift	3	SW	88.2	54	53	140	0	LR	Boats, crane
10/5/2011	16:35	Swift	1	SW	92	54.2	53	110	0	LR	boats, vibratory hammer
10/6/2011	8:55	Swift	4	SW	94.2	51.6	52.6	140	0	PC	Boats, crane
10/6/2011	10:05	Swift	3	SW	93.6	54.1	52.7	140	0	OC	Boats,
10/6/2011	13:30	Swift	2	SW	87.8	59.8	53	100	0	PC	(No boats) deck machine
10/6/2011	14:35	Swift	0	SW	74.5	60.3	53.4	100	0	OC	deck machinery
10/6/2011	15:35	Swift	2	N	84.2	55.5	53	100	0	OC	crane, deck machinery
10/6/2011	16:27	Swift	2	N	86.5	55.7	53.9	100	0	OC	crane
10/6/2011	17:12	Swift	1	N	92.4	54.1	53.5	100	0	OC	none
10/7/2011	7:30	Shocker	0	--	87	51.8	52.1	53	0	LR, FOG	--
10/7/2011	7:30	Swift	0	--	95	54.1	53	Variable	0	R	Boats
10/7/2011	8:25	Shocker	0	--	HI	54.7	52.1	44.1	0	FO	Cutting machine in EHW bldg
10/7/2011	8:30	Swift	0	--	95	55	52	162	0	C	Boats, saws, generator
10/7/2011	9:30	Swift	3	SW	95	56	52	150	0	LR	Boats, generator
10/7/2011	9:32	Shocker	0	--	HI	54	52.1	45.2	0	FO	Between vibes in EHW bldg
10/7/2011	10:30	Swift	3	SW	90	53	52	Variable	0.25	C	Boats

Date	Time	Boat	Wind Speed (mph)	Wind Direction	Humidity	Air Temp (F)	Water Temp (F)	Water Depth (ft)	Wave Height (ft)	Weather conditions	Background Sound Level Notes
<b>Boats Inside the WRA (continued)</b>											
10/7/2011	10:33	Shocker	0	--	HI	55.4	53.2	61.5	0	FO	Shocker engine, outside EHW
10/7/2011	11:23	Shocker	0	--	80	56.7	53.2	49.5	0	OC	Concrete saw in EHW
10/7/2011	12:30	Swift	6	NE	99	58	53	170	0	C	Boats, generator
10/7/2011	13:05	Shocker	0	--	HI	55.8	53.2	52	0	OC	Concrete saw in EHW
10/7/2011	13:30	Swift	7	NE	97	53	53	170	0	C	Generator
10/7/2011	14:30	Swift	6	NNE	95	53	53	170	0	C	Generator
10/7/2011	14:38	Shocker	0	--	88	56.7	52.3	52	0	OC	Crane machinery in EHW
10/7/2011	15:22	Shocker	0	N	89	56.5	53	51.9	0	OC	Crane machinery in EHW
10/7/2011	15:30	Swift	2	NNE	85	54	53	Variable	0	C	Generator, boats
10/7/2011	16:05	Shocker	0	N	74	55.8	53.2	80.1	0	OC	--
10/7/2011	16:30	Swift	2	NNE	80	54	53	Variable	0	C	Generator
10/7/2011	16:58	Shocker	0	N	82	54.9	53	50.7	0	OC	Crane, in EHW
10/7/2011	17:30	Swift	4	N	90	54	53	Variable	0	C	Vibratory hammer, generator
10/7/2011	17:45	Shocker	0	NW	87	54.3	53	50.1	0	OC	None, in EHW
10/8/2011	8:00	Swift	1	NE	87	52	52	82	0	FOG	Boats, generator
10/8/2011	8:10	Shocker	0	--	88	51.1	52.2	45	0	OC, FO	Crane operations in EHW
10/8/2011	9:00	Swift	1	--	88	52	52	Variable	0	PC	Boats, hammer, generator
10/8/2011	9:40	Shocker	0	--	HI	52.2	52.2	44.9	0	OC, FO	Crane operations in EHW
10/8/2011	13:30	Swift	11	S	82	58	52	Variable	0.25	S	Boats, generator
10/8/2011	14:00	Swift	10	S	77	59	52	Variable	0.5	S	Boats, generator
10/8/2011	14:30	Shocker	Beau = 2	SW	62	63.9	52.7	128	0.5	PC	Boat engine at Delta Pier
10/8/2011	15:20	Shocker	Beau = 2	SW	63	62.8	52.7	92	0.5	PC	Shocker engine at TP-1
10/8/2011	16:27	Shocker	Beau = 2	SW	62	63.9	52.7	58.3	0.5	PC	None, in EHW
10/8/2011	16:40	Swift	10	S	67	62	53	Variable	0.5	C	Boats, generator
10/10/2011	10:15	Swift	4	SW	91.8	53.5	56.6	115	0.2	R	
10/10/2011	11:24	Swift	3	SW	100	52.7	52.9	120	0.1	R	Tug
10/10/2011	13:11	Swift	2	SW	100	53.6	53	120	0	R	
10/10/2011	15:30	Swift	4	SW	100	56.5	53	120	0.1	OC	
10/10/2011	16:30	Swift	3	SW	100	59.5	53	120	0.1	OC	
10/11/2011	7:55	Swift	4	NW	89.6	52.8	52.4	110	0.2	PC	North EHW
10/11/2011	8:55	Swift	3	NW	89.9	53.8	52.2	110	0.3	PC	Behind barge, sheltered
10/11/2011	9:55	Swift	5	NW	84.5	56.5	52.2	110	0.4	PC	Behind barge, sheltered
10/11/2011	10:55	Swift	8	N	77.3	59.6	52.2	110	0.7 to 0.8	PC	Behind barge, sheltered
10/11/2011	11:55	Swift	9	N	68.1	64	52.2	110	0.7 to 0.8	PC	Behind barge, sheltered
10/11/2011	12:55	Swift	7	NNW	69.9	63.1	52.2	110	0.7 to 0.8	PC	Behind barge, sheltered



Date	Time	Boat	Wind Speed (mph)	Wind Direction	Humidity	Air Temp (F)	Water Temp (F)	Water Depth (ft)	Wave Height (ft)	Weather conditions	Background Sound Level Notes
<b>Boats Inside the WRA (continued)</b>											
10/11/2011	13:55	Swift	7	NNW	70.5	62.5	52.2	110	0.5	PC	Behind barge, sheltered
10/11/2011	14:55	Swift	12	NNW	71	62.1	52.2	110	0.4	PC	NW corner of EHW
10/11/2011	15:55	Swift	17	NNW	71.9	58.8	52.2	110	0.1	PC	NW corner of EHW
10/11/2011	16:55	Swift	12	NNW	77.2	58.8	52.2	110	0.2	PC	Delta pier near fence
10/12/2011	10:00	Swift	5	N	83	53.4	52.1	100	0.1	C	Delta pier near fence
10/12/2011	11:00	Swift	4	NNW	77.1	50.6	51.7	100	0 to 0.1	S	Delta pier near fence
10/12/2011	12:24	Swift	3	NNW	73	63.4	51.7	100	0	S	Delta pier near fence
10/12/2011	13:00	Swift	2	NNW	66.5	63.7	52.1	100	0	S	Delta pier near fence
10/12/2011	14:00	Swift	1	NNW	59.6	63.3	52.2	110	0	S	NW corner of EHW sheltered
10/12/2011	15:00	Swift	4	NNW	61.4	61.3	52.2	110	0.1	S	NW corner of EHW sheltered
10/12/2011	16:16	Swift	2	N	65.3	51.1	52.2	110	0 to 0.1	C	NW corner of EHW sheltered
10/12/2011	17:00	Swift	1	N	72.6	57.7	51.9	110	0	C	NW corner of EHW sheltered
10/13/2011	8:00	Swift	2	N	92.2	45.2	51.2	110	0	F	NW corner of EHW
10/13/2011	9:00	Swift	3	N	93	47.3	51.2	110	0	F	NW corner of EHW
10/13/2011	10:00	Swift	2	N	94.2	48.3	51.2	110	0	S/F	NW corner of EHW
10/13/2011	11:42	Swift	5	Variable	74.6	56	51.6	110	0	S	NW corner of EHW
10/13/2011	13:00	Swift	5	S	60.7	61.3	51.7	110	0.2	S/PC	NW corner of EHW
10/13/2011	14:00	Swift	4	S	54.7	58.6	51.7	110	0.4 to 0.5	S/PC	NW corner of EHW
10/13/2011	15:00	Swift	16	S	59.8	61.2	51.7	110	0.7	S/PC	NW corner of EHW
10/14/2011	12:00	Swift	11	S	75.2	55.1	51.7	110	0.2	C	NW corner of EHW
10/14/2011	13:05	Swift	12	S	64.4	56.7	51.6	110	0.2	C	NW corner of EHW
10/14/2011	14:00	Swift	10	S	72.4	53.2	51.7	110	0.2	C	NW corner of EHW
10/14/2011	15:00	Swift	11	S	70.9	55.8	51.7	110	0.2	C	NW corner of EHW
10/14/2011	16:00	Swift	8	S	75.4	55	51.7	110	0.1	C	NW corner of EHW
10/14/2011	17:00	Swift	8	S	68.2	54.6	51.7	110	0.1	C	NW corner of EHW
10/17/2011	10:45	Streak	0	--	--	56	52	155	0	S	
10/17/2011	11:30	Streak	2	N	65	56	52	152	0	S	
10/17/2011	12:30	Streak	4	NNW	66	65	52	55	0	PC	
10/17/2011	14:00	Streak	8	N	62	56	52	54	0	PC	
10/17/2011	15:15	Streak	8	NNE	52	52	52	54	0	PC	
10/18/2011	11:50	Streak	5	NW	76	57	50	50	0	S	
10/18/2011	13:10	Streak	3	NW	72	58	51	50	0	S	
10/18/2011	14:10	Streak	4	NW	85	55	51.6	50	0	S	
10/18/2011	15:10	Streak	4	NW	71.5	58	51	50	0	S	

Date	Time	Boat	Wind Speed (mph)	Wind Direction	Humidity	Air Temp (F)	Water Temp (F)	Water Depth (ft)	Wave Height (ft)	Weather conditions	Background Sound Level Notes
<b>Boats Outside the WRA</b>											
8/26/2011	8:00	Mary K	1	N	Fog	--	58	Variable	0	F/S	--
8/29/2011	10:00	Mary K	0	--	--	69.9	56	195	--	OC	--
8/29/2011	13:30	Mary K	0	--	--	--	--	220	--	OC	--
8/29/2011	15:16	Mary K	2	--	--	82.4	61	236	--	OC	--
8/31/2011	8:15	Mary K	--	N	--	--	58	256	<1	PS	--
8/31/2011	9:19	Mary K	--	N	--	--	59	280	<1	PS	--
8/31/2011	10:15	Mary K	--	N	--	--	58	300	<1	PS	--
8/31/2011	11:13	Mary K	--	N	--	--	59	216	<1	PS	--
8/31/2011	11:39	Mary K	--	--	--	--	61	275	<1	PS	--
8/31/2011	13:15	Mary K	--	S	--	--	62	285	<1	PS	--
8/31/2011	14:00	Mary K	--	S	--	--	60	226	Beau 2 to 3	MS	--
8/31/2011	14:15	Mary K	--	S	--	--	60	240	<1	MS	--
9/1/2011	8:27	Mary K	1	N	--	63.5	59	253	<1	F	
9/1/2011	9:24	Mary K	1	N	--	71.6	60	255	<1	PS	0.66 mi from pile
9/1/2011	10:32	Mary K	2	N	--	68	61	255	<1	S	
9/1/2011	11:19	Shawnee II	5	N	30	68.5	43.7	207	3	SUN	
9/1/2011	12:45	Mary K	2	N	--	75	61	260	<1	S	
9/1/2011	14:30	Mary K	0	--	--	--	63	283	<1	S	
9/1/2011	14:31	Shawnee II	3	N	30	72.9	51.3	204	0.1	SUN	
9/1/2011	15:23	Mary K	2	S	--	--	63	2226	<1	S	
9/8/2011	8:30	Mary K	0	--	--	71.4	52	44	0	S	motors in distance
9/8/2011	9:40	Mary K	0	--	--	65.4	58	385	<1	S	motors in distance
9/8/2011	10:44	Ugle	0	--	55	68	57	216	0	S	--
9/8/2011	10:55	Mary K	0	--	--	78	60	413	<1	S	motors in distance
9/8/2011	12:00	Mary K	0	--	--	72.5	60	318	<1	S	
9/8/2011	13:00	Mary K	1	S	--	79.5	64	300	<1	S	
9/8/2011	13:30	Mary K	7	S	--	74.1	59	318	1	S	
9/8/2011	14:00	Ugle	10	S	55	84	57	277	0.75	S	--
9/8/2011	13:71	Ugle	3	N	55	85	57	255	0.25	S	--
9/8/2011	14:25	Mary K	8	S	--	71	58	338	<1	S	
9/8/2011	15:25	Mary K	6	S	--	72.8	59	328	<1	S	
9/8/2011	15:27	Ugle	6	S	55	85	57	235	0.5	S	--

Date	Time	Boat	Wind Speed (mph)	Wind Direction	Humidity	Air Temp (F)	Water Temp (F)	Water Depth (ft)	Wave Height (ft)	Weather conditions	Background Sound Level Notes
<b>Boats Outside the WRA (continued)</b>											
9/8/2011	16:30	Mary K	4	S	--	75	60	--	<1	S	Depth finder not used during acoustics monitoring
9/8/2011	17:30	Mary K	0	--	--	80	65	124	0	S	--
9/15/2011	10:30	Mary K	0	--	--	59.5	58	375	0	OC	--
9/15/2011	12:35	Mary K	0	--	--	52.2	60	180	0	OC	--
9/16/2011	9:30	Mary K	--	--	--	--	57	--	1.5	OC	--
9/16/2011	10:35	Mary K	--	--	--	--	--	--	0	OC	--
9/16/2011	11:35	Mary K	--	--	--	--	58	--	0	OC	--
9/16/2011	12:39	Mary K	--	--	--	--	60	--	0	OC	--
9/16/2011	13:25	Mary K	--	--	--	--	60	--	0	OC	--
9/17/2011	10:30	Mary K	--	--	--	--	57	--	1.5	OC	--
9/17/2011	11:30	Mary K	--	--	--	--	57	--	1.5	OC	--
9/17/2011	13:11	Mary K	--	--	--	--	58	--	1.5	OC	--
9/17/2011	15:00	Mary K	--	--	--	--	60	--	0.5	OC	--
9/17/2011	16:15	Mary K	--	--	--	--	60	--	0.5	OC	--
9/21/2011	9:15	Ugle	0	--	--	70.3	59	199	--	--	
9/21/2011	10:15	Ugle	0	--	--	77.3	-	200	--	--	
9/21/2011	10:50	Ugle	5	--	--	77.7	-	150	--	--	
9/21/2011	12:30	Ugle	8	--	--	82	-	125	--	--	
9/21/2011	13:25	Ugle	14	--	--	81.5	56	140	--	--	
9/21/2011	14:32	Ugle	14	--	--	77	56	140	--	--	
9/21/2011	15:23	Ugle	6	--	--	80.7	56	200	--	--	
9/21/2011	16:40	Ugle	12	--	--	80.6	56	200	--	--	
9/22/2011	9:15	Ugle	16	SW	--	64.2	56	305	--	--	
9/22/2011	14:55	Ugle	14	--	--	77.7	56	250	--	--	
9/23/2011	08:56	Ugle	17	SW	--	74.1	-	-	--	--	
9/23/2011	10:20	Ugle	22	SW	--	81.8	55	255	--	--	
9/23/2011	10:50	Ugle	27	SW	--	-	55	240	--	--	
9/23/2011	1:615	Ugle	22	SW	--	81	55	240	--	--	
9/23/2011	12:30	Ugle	25	SW	--	83	55	245	--	--	
9/23/2011	13:15	Ugle	21	SW	--	83.4	55	245	--	--	
9/23/2011	14:50	Ugle	26	SW	--	82	55	245	--	--	
9/24/2011	9:00	Ugle	0	--	--	64	55	105	--	--	
9/24/2011	11:20	Ugle	8	--	--	77	54	216	--	--	
9/24/2011	12:15	Ugle	12	--	--	78	54	216	--	--	

Date	Time	Boat	Wind Speed (mph)	Wind Direction	Humidity	Air Temp (F)	Water Temp (F)	Water Depth (ft)	Wave Height (ft)	Weather conditions	Background Sound Level Notes
<b>Boats Outside the WRA (continued)</b>											
9/24/2011	13:05	Ugle	8	--	--	-	54	265	--	--	
9/24/2011	14:00	Ugle	10	--	--	-	54	265	--	--	
9/24/2011	14:50	Ugle	10	--	--	-	54	120	--	--	
9/24/2011	15:50	Ugle	11	--	--	-	54	100	--	--	
9/26/2011	9:00	Shawnee II	10	SSE	100	65	55	255	1	FOG, R	
9/26/2011	9:15	Ugle	--	--	1	--	--	--	1.5	R	
9/26/2011	10:00	Shawnee II	10	SSE	100	60	55	185	1	FOG, R	
9/26/2011	10:20	Ugle	--	--	2	--	--	52.1	1.5	R	
9/26/2011	11:00	Mary K	--	--	--	--	52	340	1	LR	
9/26/2011	11:00	Shawnee II	15	SSE	100	60	55	200	1	FOG, R	Building wind
9/26/2011	11:22	Ugle	--	--	1	--	--	52.6	0.5	R	
9/26/2011	12:00	Mary K	--	--	--	--	52	338	1.5	LR	
9/29/2011	8:40	Mary K	2	E	--	49	55	--	0	S	At dock
9/29/2011	9:10	Mary K	0	--	--	59.7	51	262	0	S	
9/29/2011	9:20	Mary K	--	--	--	63.6	50	264	<1	S	
9/29/2011	10:10	Mary K	2	S	--	--	52	--	<1	S	Boat not running, ambient sound measurements in progress
9/29/2011	10:15	Mary K	2	5 deg	--	--	50	264	<1	S	
9/29/2011	11:05	Mary K	3	S	--	58.6	53	325	<1	S	
9/29/2011	12:10	Mary K	2	S	--	69.6	55	132	<1	S	
9/29/2011	13:20	Mary K	5	S	--	64.7	54	39	<1	S	
9/29/2011	14:20	Mary K	0	--	--	69.4	54	39	<1	S	
9/29/2011	15:10	Mary K	0	--	--	81.3	54	293	<1	S	
9/29/2011	16:20	Mary K	0	--	--	73.5	57	340	<1	S	
9/29/2011	17:20	Mary K	3	S	--	71.9	60	383	<1	S	
9/30/2011	8:30	Shawnee II	0	--	--	62	55	263	0	OC	
9/30/2011	8:47	Mary K	0	--	--	56.7	52	351	0	S	3 cranes near Delta
9/30/2011	9:37	Mary K	0	--	--	64.7	52	325	0	S	At 2km from pile
9/30/2011	10:42	Mary K	0	--	--	64.5	53	312	0	S	At 5.95 km from pile
9/30/2011	11:40	Mary K	0	--	--	62.7	--	178	0	PC	At 5.94km from pile
9/30/2011	12:47	Mary K	5	N	--	59.9	53	308	0	OC, R	At 1.7km form pile (vibing)

Date	Time	Boat	Wind Speed (mph)	Wind Direction	Humidity	Air Temp (F)	Water Temp (F)	Water Depth (ft)	Wave Height (ft)	Weather conditions	Background Sound Level Notes
<b>Boats Outside the WRA (continued)</b>											
9/30/2011	13:44	Mary K	7	N	--	60.9	53	300	0.3	PC	At 1.7km from pile (vibing)
9/30/2011	14:43	Mary K	15	N	--	61.3	--	--	0.5	PC	At 3.18k from pile (vibing)
9/30/2011	15:57	Mary K	--		--	--	--	--	1	--	At Carderock Pier
10/1/2011	8:43	Mary K	2	SE	HI	53.6	52	310	0	OC	At 1.24K South of TP-9
10/1/2011	9:46	Mary K	2	S	HI	56.8	52	333	0	OC	At 1.2 K South of TP-9
10/1/2011	10:40	Mary K	0	--	HI	59.5	52	373	0	OC	At 1.33 K from TP-9
10/1/2011	11:44	Mary K	0	--	HI	61.8	53	340	0	OC	At 840m from TP-9
10/1/2011	13:20	Mary K	0	--	HI	58.1	53	318	0	OC	At 1.12K from TP-9
10/1/2011	14:14	Mary K	0	--	HI	59	53	255	0	OC	At 885m from TP-9
10/1/2011	15:20	Mary K	2	N	HI	55.2	53	265	0.2	OC	At 912m from TP-9
10/1/2011	16:14	Mary K	3	N	HI	54.6	53	273	0	OC, R	At 944m from TP-9
10/3/2011	7:45	Ugle	4	N	--	55.6	53	40	0	OC	At Dock
10/3/2011	8:30	Ugle	18	N	--	53.1	53	225	2	R	
10/3/2011	9:44	Mary K	8	190 deg	--	58.2	52	--	1.5	OC	
10/3/2011	10:00	Ugle	7	N	--	61.1	53	225	0.5	OC	
10/3/2011	11:00	Ugle	8	N	--	58.1	53	225	2.5	OC	
10/3/2011	11:35	Mary K	8	190 deg	--	61.8	52	370	1	OC	
10/3/2011	12:16	Ugle	4	N	--	59.5	53	213	1	OC	
10/3/2011	13:16	Ugle	7	N	--	65.1	53.1	203	1	OC	
10/3/2011	14:10	Mary K	13	170 deg	--	63.3	54	275	1	OC	Distance to pile 5560
10/3/2011	15:40	Mary K	7	190 deg	--	62.2	55	268	1	OC	Distance to pile 965
10/3/2011	18:20	Mary K	8	190 deg	--	57.5	--	413	1	OC	Distance to pile 1700
10/4/2011	7:30	Ugle	2	N	--	56.8	52.7	200	<1	OC	
10/4/2011	9:30	Ugle	4	N	--	58.7	52.6	190	<1	OC	
10/4/2011	10:30	Ugle	0	--	--	64.5	52.6	40	<1	OC	At Dock
10/4/2011	11:30	Ugle	0	--	--	68.7	52.6	385	<1	OC	
10/4/2011	12:30	Ugle	0	--	--	66	52.6	380	0	OC	
10/4/2011	13:30	Ugle	0	--	--	65.6	52.6	211	0	OC	
10/4/2011	14:41	Ugle	6	N	--	59.8	53.5	220	<1	OC	
10/4/2011	15:30	Ugle	0	N	--	65.6	52.6	211	0	R	
10/4/2011	15:31	Ugle	10	N	--	55.5	53.2	220	<1	LR	
10/6/2011	9:20	Ugle	3	N	--	59.5	52.4	165	<1	S	
10/6/2011	10:20	Ugle	2	N	--	57.7	52.6	160	<1	OC	
10/6/2011	13:20	Ugle	4	N	--	56.5	52.7	164	<1	OC	
10/6/2011	15:00	Ugle	1	N	--	62.1	53.5	162	<1	OC	



Date	Time	Boat	Wind Speed (mph)	Wind Direction	Humidity	Air Temp (F)	Water Temp (F)	Water Depth (ft)	Wave Height (ft)	Weather conditions	Background Sound Level Notes
<b>Boats Outside the WRA (continued)</b>											
10/6/2011	16:00	Ugle	0	--	--	60.6	53	163	0	OC	
10/6/2011	17:00	Ugle	0	--	--	59	53.7	162	0	OC	
10/7/2011	7:50	Ugle	0	--	--	57.1	52.7	75	0	OC	
10/7/2011	10:30	Ugle	3	S	--	61.5	53	235	<1	OC	
10/7/2011	11:30	Ugle	2	S	--	61.3	53	235	<1	OC	
10/7/2011	12:30	Ugle	2	S	--	61	53	289	<1	OC	
10/7/2011	14:30	Ugle	1	S	--	56.6	53	258	1	OC	
10/7/2011	15:30	Ugle	0	--	--	60.8	53	250	0	OC	
10/7/2011	16:30	Ugle	0	--	--	61.8	53	250	0	OC	
10/8/2011	8:20	Ugle	0	--	--	55.5	52.4	357	0	--	
10/8/2011	9:30	Ugle	2	N	--	56.5	52.1	350	<1	--	
10/8/2011	10:30	Ugle	6	N	--	57.9	52.4	350	<1	--	
10/8/2011	11:30	Ugle	7	N	--	68.1	52.4	230	1 to 2	--	
10/8/2011	12:30	Ugle	8	N	--	77.5	52.6	215	1 to 2	--	
10/8/2011	13:30	Ugle	11	N	--	70.1	52.4	130	1 to 2	--	
10/8/2011	14:30	Ugle	10	N	--	73.2	52.6	220	2 to 3	--	
10/8/2011	15:30	Ugle	12	N	--	64.5	52.2	180	3	--	
10/8/2011	16:30	Ugle	20	N	--	65.1	52.6	180	2	--	
10/10/2011	11:10	Ugle	2	S	--	59	52.4	50	--	--	
10/10/2011	12:10	Ugle	8	SW	--	57.7	52.9	259	--	--	
10/10/2011	13:10	Ugle	4	S	--	59.5	--	287	--	--	
10/10/2011	14:10	Ugle	7	S	--	57.9	--	260	--	--	
10/10/2011	15:10	Ugle	9	S	--	61.7	--	260	--	--	
10/10/2011	16:10	Ugle	3	SW	--	61	--	260	--	--	
10/10/2011	16:50	Ugle	18	S	--	60	--	260	--	--	
10/11/2011	7:55	Ugle	13	SW	--	54.1	--	200	1 to 2	--	
10/11/2011	8:55	Ugle	17	S	--	55.5	52	240	2 to 3	--	
10/11/2011	9:55	Ugle	15	S	--	68	52	240	2 to 3	--	
10/11/2011	10:03	Ugle	19	S	--	65	52	240	3 to 4	--	
10/11/2011	10:50	Ugle	21	S	--	65	52	240	2 to 3	--	
10/11/2011	11:50	Ugle	13	S	--	68	52	252	1 to 2	--	
10/11/2011	12:50	Ugle	17	S	--	64	52	132	1 to 2	--	
10/11/2011	13:30	Ugle	19	S	--	71	52	132	2	--	
10/11/2011	14:10	Ugle	16	S	--	70	52	132	1 to 2	--	
10/11/2011	15:10	Ugle	13	S	--	68	52	132	1 to 2	--	

Date	Time	Boat	Wind Speed (mph)	Wind Direction	Humidity	Air Temp (F)	Water Temp (F)	Water Depth (ft)	Wave Height (ft)	Weather conditions	Background Sound Level Notes
<b>Boats Outside the WRA (continued)</b>											
10/11/2011	16:10	Ugle	17	S	--	64	52	132	1 to 2	--	
10/11/2011	17:00	Ugle	11	S	--	61	52	132	1	--	
10/12/2011	8:30	Ugle	8	S	--	53.4	52	240	1	--	
10/12/2011	9:30	Ugle	5	S	--	56.8	52	240	<1	--	
10/12/2011	10:35	Ugle	2	S	--	66.6	51.6	240	<1	--	
10/12/2011	11:30	Ugle	4	S	--	66	51.6	240	<1	--	
10/12/2011	12:45	Ugle	0	--	--	68.2	51.6	240	<1	--	
10/12/2011	13:43	Ugle	0	--	--	--	51.6	240	<1	--	
10/12/2011	14:30	Ugle	3	W	--	66	51.6	240	<1	--	
10/12/2011	15:30	Ugle	1	SW	--	63.3	51.6	240	<1	--	
10/12/2011	16:30	Ugle	2	W	--	64.4	51.6	240	<1	--	
10/12/2011	18:00	Ugle	1	NW	--	64.5	51.4	368	<1	--	
10/13/2011	8:22	Ugle	0	--	--	53.8	50.7	103	<1	--	
10/13/2011	9:22	Ugle	0	--	--	53.9	50.6	103	<1	--	
10/13/2011	10:30	Ugle	0	--	--	55	50.9	100	<1	--	
10/13/2011	11:20	Ugle	4	N	--	60.3	51.6	227	<1	--	
10/13/2011	12:20	Ugle	8	N	--	62.3	51.6	231	1 to 2	--	
10/13/2011	13:20	Ugle	12	N	--	64	51.6	260	1 to 2	--	
10/13/2011	14:20	Ugle	13	N	--	64.2	51.6	250	2	--	
10/13/2011	15:26	Ugle	10	N	--	65.3	51.7	249	1 to 2	--	
10/14/2011	11:34	Ugle	10	N	--	59.9	51.7	249	1 to 2	--	
10/14/2011	12:30	Ugle	7	N	--	64	51.4	266	1 to 2	--	
10/14/2011	13:30	Ugle	7	N	--	64	51.4	268	1	--	
10/14/2011	14:37	Ugle	7	N	--	59.9	51.4	270	1	--	
10/14/2011	15:30	Ugle	3	N	--	63.3	51.4	270	1	--	
10/14/2011	16:30	Ugle	6	N	--	61.1	51.4	270	1	--	
10/14/2011	17:23	Ugle	8	N	--	56.6	51.4	270	<1	--	
10/15/2011	8:25	Ugle	0	--	--	-	52	-	-	--	
10/15/2011	9:10	Ugle	0	--	--	-	54	50.9	170	--	
10/15/2011	10:00	Ugle	9	--	--	-	55	50.9	170	--	
10/15/2011	10:42	Ugle	9	--	--	-	56	50.9	170	--	
10/15/2011	11:35	Ugle	8	--	--	-	56	51.2	278	--	
10/15/2011	12:30	Ugle	10	--	--	-	60	51.2	278	--	
10/17/2011	8:34	Ugle	7	S	--	50.1	51	320	<1	--	
10/17/2011	9:33	Ugle	4	SW	--	59.5	51.4	266	<1	--	

Date	Time	Boat	Wind Speed (mph)	Wind Direction	Humidity	Air Temp (F)	Water Temp (F)	Water Depth (ft)	Wave Height (ft)	Weather conditions	Background Sound Level Notes
<b>Boats Outside the WRA (continued)</b>											
10/17/2011	10:30	Ugle	1	S	--	60	51.9	220	<1	--	
10/17/2011	12:28	Ugle	1	S	--	67.2	52.6	238	<1	--	
10/17/2011	13:30	Ugle	1	W	--	69.8	52.9	230	<1	--	
10/17/2011	14:30	Ugle	6	NNE	--	62.3	52.9	230	1 to 2	--	
10/17/2011	15:30	Ugle	6	NE	--	66.7	52.9	230	2	--	
10/17/2011	16:30	Ugle	8	NE	--	70.7	52.9	230	1 to 2	--	
10/18/2011	11:32	Ugle	6	N	--	60.8	--	263	<1	--	
10/18/2011	12:30	Ugle	5	N	--	60.5	--	263	1	--	
10/18/2011	13:30	Ugle	6	N	--	64.3	--	263	1	--	
10/18/2011	14:30	Ugle	9	NW	--	66	--	263	1	--	
10/18/2011	15:29	Ugle	10	N	--	66.3	--	263	1 to 2	--	
10/19/2011	8:30	Ugle		S	--	55.6	51.2	270	<1	S	
10/19/2011	9:30	Ugle		N	--	60	51.2	270	<1	S	
10/19/2011	10:30	Ugle		N	--	64.2	51.2	270	<1	S	
10/19/2011	11:30	Ugle		N	--	66.2	51.2	270	<1	S	
10/19/2011	12:30	Ugle		N	--	68	51.2	270	<1	S	
10/19/2011	13:30	Ugle		S	--	64.4	51.2	270	<1	S	
10/19/2011	14:30	Ugle		S	--	68	51.2	270	1	OC	
10/19/2011	15:30	Ugle		SE	--	66.9	51.2	270	<1	OC	
10/19/2011	16:30	Ugle		S	--	65.1	51.2	270	<1	OC	
10/20/2011	8:30	Ugle		N	--	53.8	52	275	<1	OC	
10/20/2011	9:30	Ugle		N	--	54.5	52	275	<1	OC	
10/20/2011	10:30	Ugle		N	--	53.2	52	275	<1	OC	
10/20/2011	11:30	Ugle		N	--	53.5	52	275	<1	LR	
10/20/2011	12:30	Ugle		N	--	52.1	52	275	1	LR	
10/20/2011	13:30	Ugle		N	--	52.1	52	275	<1	LR	

## APPENDIX D

### Example Data Sheet

<b>Marine Mammal Observation Record Form</b>										Observer(s):		Date:	
Boat Name/Location:				Time Effort Initiated:						Page _____ of _____ Pages			
				Time Effort Completed:									
Project Name	Sighting #	Sighting Time	Latitude	Longitude	Species	# of Anim	Dist/Dir to Anim	Beh Type(s)	Const Type	Dist to Pile	Weath Cond	Beauf	Notes

***THIS PAGE INTENTIONALLY LEFT BLANK***



## APPENDIX E

### Sighting Codes

#### Behavior codes

Code	Behavior	Definition
BR	Breaching	Leaps clear of water
CD	Change Direction	Suddenly changes direction of travel
CH	Chuff	Makes loud, forceful exhalation of air at surface
DI	Dive	Forward dives below surface
DE	Dead	Shows decomposition or is confirmed as dead by investigation
DS	Disorientation	An individual displaying multiple behaviors that have no clear direction or purpose
FI	Fight	Agonistic interactions between two or more individuals
FO	Foraging	Confirmed by food seen in mouth
MI	Milling	Moving slowly at surface, changing direction often, not moving in any particular direction
PL	Play	Behavior that does not seem to be directed towards a particular goal; may involve one, two or more individuals
PO	Porpoising	Moving rapidly with body breaking surface of water
SL	Slap	Vigorously slaps surface of water with body, flippers, tail etc.
SP	Spyhopping	Rises vertically in the water to "look" above the water
SW	Swimming	General progress in a direction. Note general direction of travel when last seen [Example: "SW (N)" for swimming north]
TR	Traveling	Traveling in an obvious direction. Note direction of travel when last seen [Example: "TR (N)" for traveling north]
UN	Unknown	Behavior of animal undetermined, does not fit into another behavior
<b>Pinniped only</b>		
EW	Enter Water (from haul out )	Enters water from a haul-out for no obvious reason
FL	Flush (from haul out )	Enters water in response to disturbance
HO	Haul out (from water)	Hauls out on land
RE	Resting	Resting onshore or on surface of water
LO	Look	Is upright in water "looking" in several directions or at a single focus
SI	Sink	Sinks out of sight below surface without obvious effort (usually from an upright position)
VO	Vocalizing	Animal emits barks, squeals, etc.
<b>Cetacean only</b>		
LG	Logging	Resting on surface of water with no obvious signs of movement

**Project Name**

Code	Activity Type
EHW	Explosives Handling Wharf
TPP	Test Pile Program

**Construction Type**

Code	Activity Type
I	Impact Pile Driving
V	Vibratory Pile Driving
SSI	Soft Start (Impact)
SSV	Soft Start (Vibratory)
NA	No Pile Driving

**Weather Conditions**

Code	Weather Condition
S	Sunny
PC	Partly Cloudy
L	Light Rain
R	Steady Rain
F	Fog
OC	Overcast

**Marine Mammal Species**

Code	Marine Mammal Species
CASL	California Sea Lion
HSEA	Harbor Seal
STSL	Steller Sea Lion
RIVO	River Otter
HPOR	Harbor Porpoise
DPOR	Dall's Porpoise
ORCA	Killer Whale
HUMP	Humpback Whale
UNLW	Unknown Large Whale
OTHR	Other
UNKW	Unknown

## APPENDIX F

### Air Bubble Curtain Underwater Sound Mitigation System

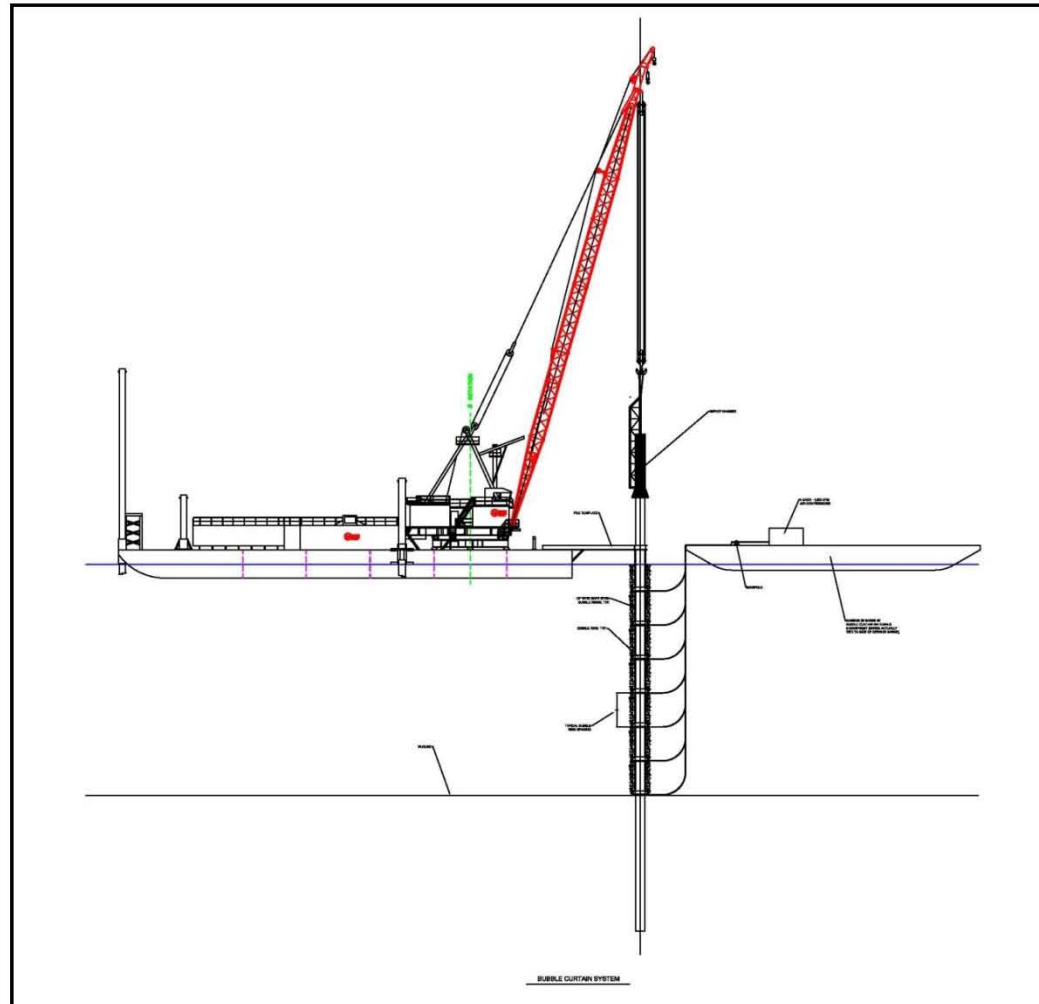


Figure F-1. Bubble Curtain Design

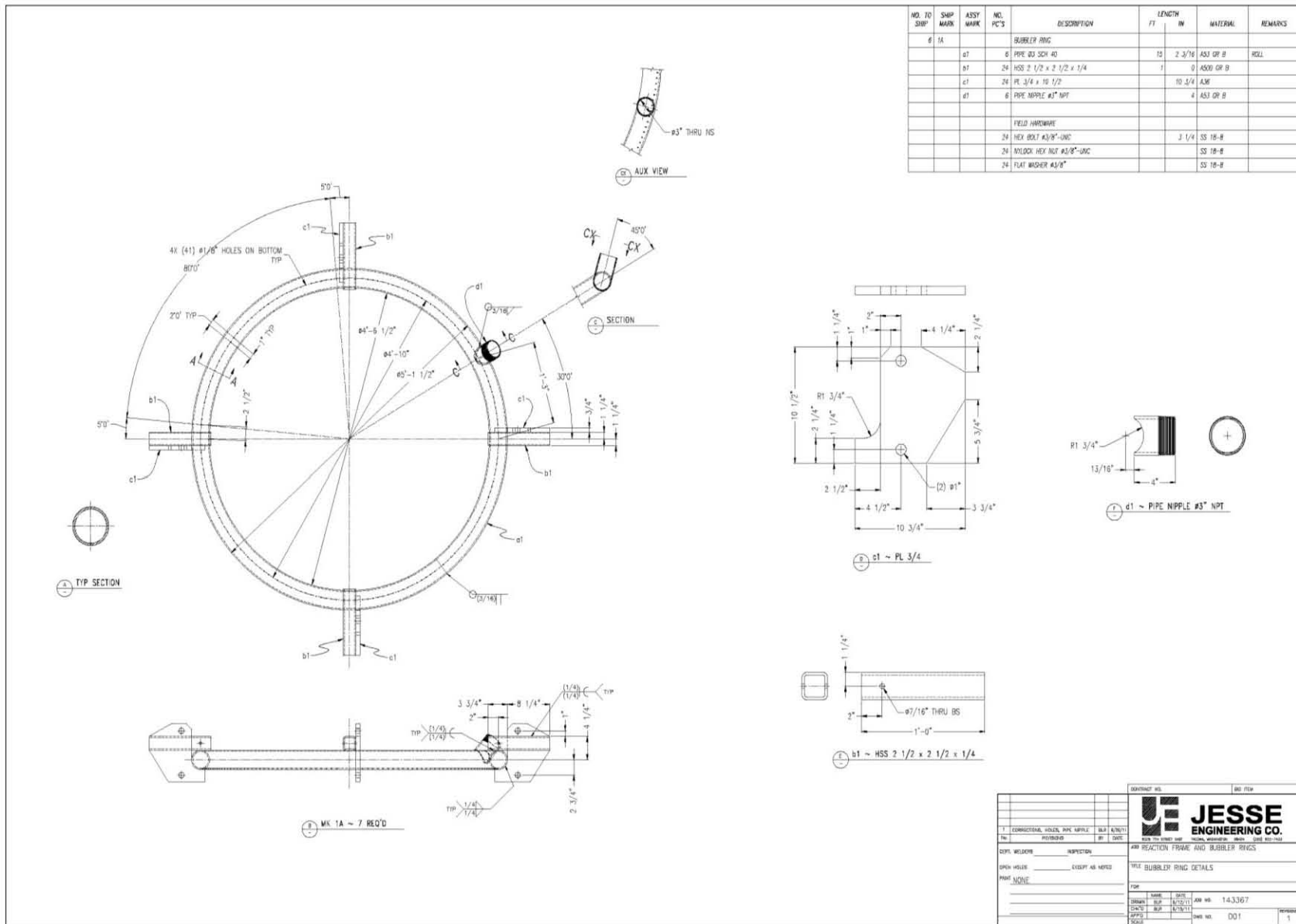


Figure F-2. Bubble Curtain Shop Drawings

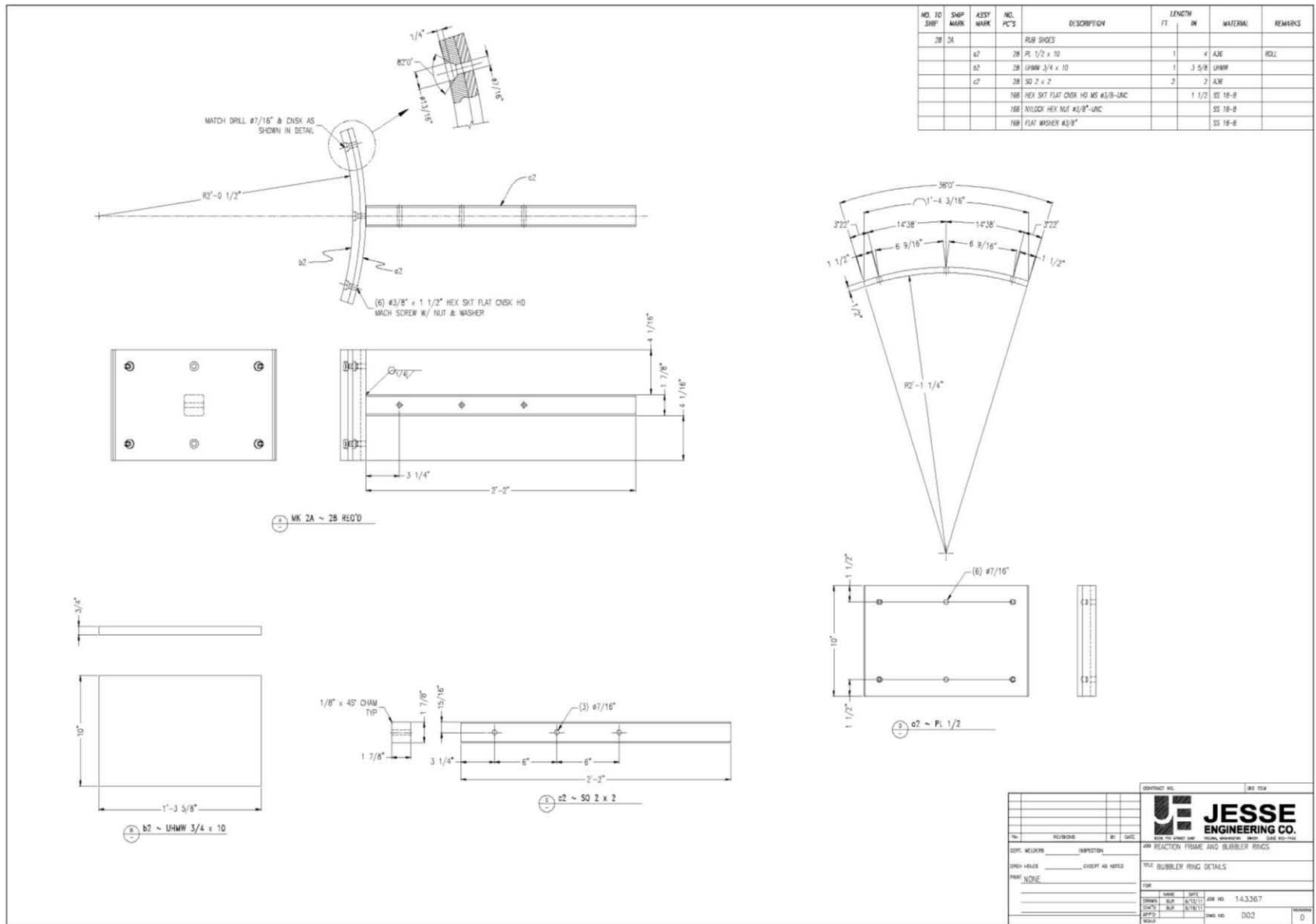


Figure F-2. Bubble Curtain Shop Drawings (continued)



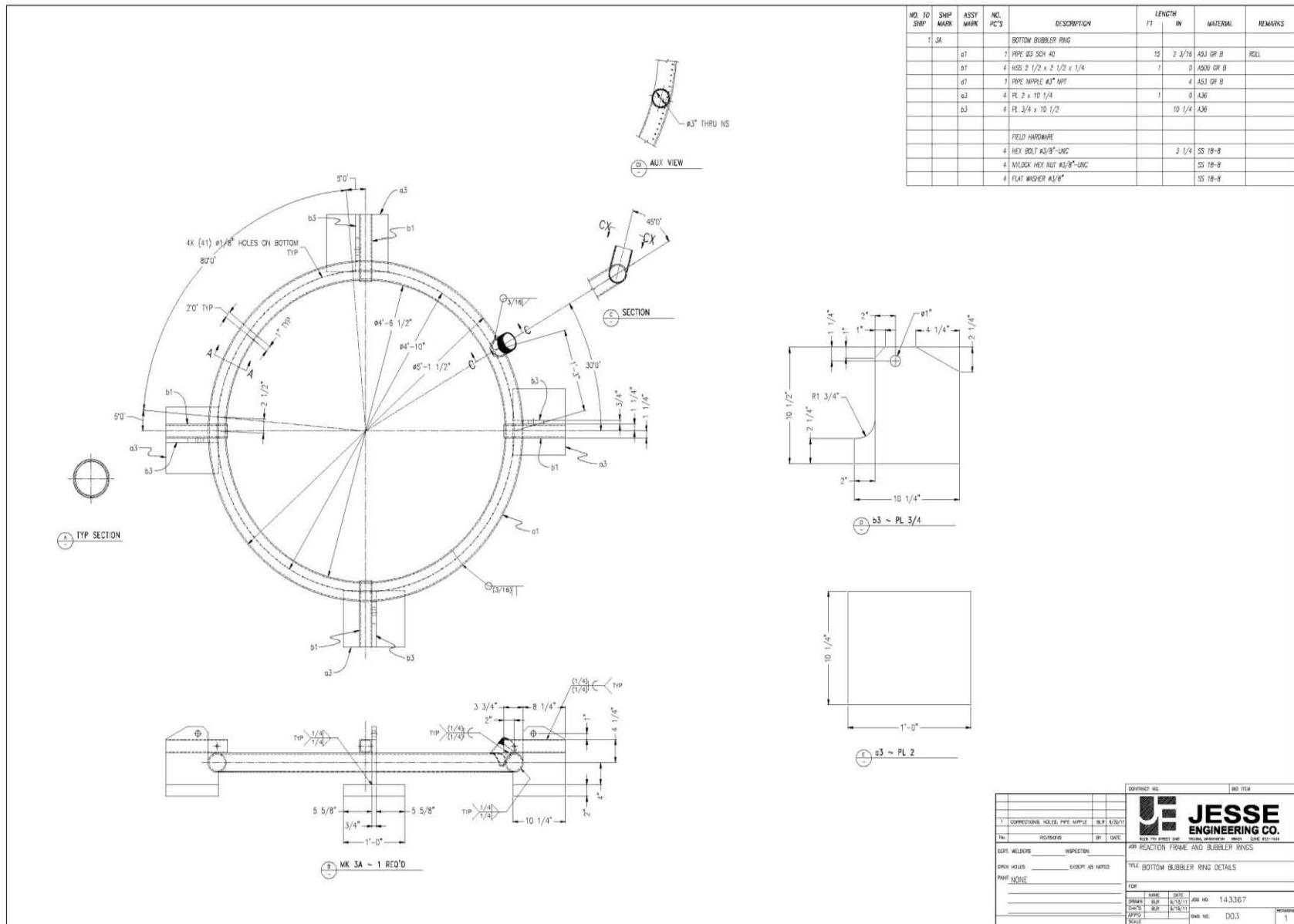


Figure F-2. Bubble Curtain Shop Drawings (continued)

## APPENDIX G

### Underwater and Airborne Marine Mammal Takes for the TPP for All Vibratory and Impact Driving Events

Sighting Date	Sighting Time (hh:mm)	Number of Individuals	Pile Driving Type	Actual Distance from Animal(s) to Pile (m)	190 dB RMS		180 dB RMS		160 dB RMS		120 dB RMS		100 dB RMS		90 dB RMS	
					Distance (m) to Threshold	Take	Distance (m) to Threshold	Take	Distance (m) to Threshold	Take	Distance (m) to Threshold	Take	Distance (m) to Threshold	Take	Distance (m) to Threshold	Take
<b>California Sea Lion</b>																
31-Aug-11	9:40	8	Vibratory	1203	<10	0	<10	0	NA	NA	6250	8	31	0	NA	NA
31-Aug-11	12:02	1	Vibratory (Soft Start)	1159	<10	0	<10	0	NA	NA	13400	1	36	0	NA	NA
16-Sep-11	15:10	1	Impact	1251	10	0	<10	0	800	0	NA		75	0	NA	NA
30-Sep-11	11:37	1	Vibratory	1082	<10	0	<10	0	NA	NA	2850	1	16	0	NA	NA
4-Oct-11	11:01	1	Vibratory	68	<10	0	<10	0	NA	NA	4900	1	15	0	NA	NA
17-Oct-11	12:58	3	Vibratory (Soft Start)	1190	<10	0	<10	0	NA	NA	4200	3	39	0	NA	NA
17-Oct-11	15:16	2	Vibratory (Soft Start)	1188	<10	0	<10	0	NA	NA	4800	2	39	0	NA	NA
17-Oct-11	15:19	2	Vibratory (Soft Start)	1197	<10	0	<10	0	NA	NA	4800	2	39	0	NA	NA
18-Oct-11	11:21	2	Vibratory (Soft Start)	1197	<10	0	<10	0	NA	NA	6000	2	39	0	NA	NA
18-Oct-11	14:28	25	Vibratory	1198	<10	0	<10	0	NA	NA	6200	25	39	0	NA	NA
19-Oct-11	10:20	2	Vibratory (Soft Start)	1008	<10	0	<10	0	NA	NA	1900	2	39	0	NA	NA
20-Oct-11	8:42	17	Vibratory (Soft Start)	874	<10	0	<10	0	NA	NA	2500	17	39	0	NA	NA
20-Oct-11	8:43	17	Vibratory (Soft Start)	874	<10	0	<10	0	NA	NA	2500	17	39	0	NA	NA
20-Oct-11	8:45	17	Vibratory	874	<10	0	<10	0	NA	NA	2500	17	39	0	NA	NA
20-Oct-11	8:50	1	Vibratory	1024	<10	0	<10	0	NA	NA	2500	1	39	0	NA	NA
20-Oct-11	8:54	18	Vibratory	874	<10	0	<10	0	NA	NA	2500	18	39	0	NA	NA
20-Oct-11	10:46	23	Vibratory (Soft Start)	874	<10	0	<10	0	NA	NA	5100	23	39	0	NA	NA
20-Oct-11	10:46	25	Vibratory (Soft Start)	874	<10	0	<10	0	NA	NA	5100	25	39	0	NA	NA
20-Oct-11	10:47	2	Vibratory (Soft Start)	1024	<10	0	<10	0	NA	NA	5100	2	39	0	NA	NA

Sighting Date	Sighting Time (hh:mm)	Number of Individuals	Pile Driving Type	Actual Distance from Animal(s) to Pile (m)	190 dB RMS		180 dB RMS		160 dB RMS		120 dB RMS		100 dB RMS		90 dB RMS	
					Distance (m) to Threshold	Take	Distance (m) to Threshold	Take	Distance (m) to Threshold	Take	Distance (m) to Threshold	Take	Distance (m) to Threshold	Take	Distance (m) to Threshold	Take
<b>California Sea Lion (continued)</b>																
20-Oct-11	11:42	27	Vibratory (Soft Start)	874	<10	0	<10	0	NA	NA	1100	27	39	0	NA	NA
20-Oct-11	14:04	24	Vibratory	890	<10	0	<10	0	NA	NA	7000	24	39	0	NA	NA
<b>Take Subtotal</b>						<b>0</b>		<b>0</b>		<b>0</b>		<b>0</b>		<b>0</b>		<b>0</b>
<b>Harbor Seal</b>																
29-Aug-11	12:19	1	Vibratory	2466	<10	0	<10	0	NA	NA	1200	0	NA	NA	60	0
29-Aug-11	12:20	2	Vibratory	72	<10	0	<10	0	NA	NA	1200	2	NA	NA	60	0
29-Aug-11	15:07	3	Vibratory (Soft Start)	2039	<10	0	<10	0	NA	NA	1975	0	NA	NA	67	0
29-Aug-11	15:08	1	Vibratory (Soft Start)	500	<10	0	<10	0	NA	NA	1975	1	NA	NA	67	0
29-Aug-11	15:13	2	Vibratory	125	<10	0	<10	0	NA	NA	1975	2	NA	NA	67	0
30-Aug-11	9:59	2	Vibratory	172	<10	0	10	0	NA	NA	3750	2	NA	NA	119	0
30-Aug-11	10:00	1	Vibratory	2557	<10	0	10	0	NA	NA	3750	1	NA	NA	119	0
30-Aug-11	10:12	1	Vibratory	1294	<10	0	10	0	NA	NA	3750	1	NA	NA	119	0
30-Aug-11	14:51	2	Vibratory	242	<10	0	<10	0	NA	NA	5500	2	NA	NA	84	0
31-Aug-11	9:42	2	Vibratory	185	<10	0	<10	0	NA	NA	6250	2	NA	NA	99	0
31-Aug-11	9:46	1	Vibratory	143	<10	0	<10	0	NA	NA	6250	1	NA	NA	99	0
31-Aug-11	9:50	1	Vibratory	175	<10	0	<10	0	NA	NA	6250	1	NA	NA	99	0
31-Aug-11	9:51	2	Vibratory	883	<10	0	<10	0	NA	NA	6250	2	NA	NA	99	0
31-Aug-11	12:01	1	Vibratory (Soft Start)	362	<10	0	<10	0	NA	NA	13400	1	NA	NA	112	0
31-Aug-11	14:26	1	Vibratory (Soft Start)	131	<10	0	<10	0	NA	NA	10250	1	NA	NA	79	0
31-Aug-11	14:27	1	Vibratory	840	<10	0	<10	0	NA	NA	10250	1	NA	NA	79	0
8-Sep-11	14:34	2	Vibratory (Soft Start)	355	<10	0	<10	0	NA	NA	2750	2	NA	NA	82	0
8-Sep-11	14:41	1	Vibratory	148	<10	0	<10	0	NA	NA	2750	1	NA	NA	82	0
8-Sep-11	16:20	2	Vibratory (Soft Start)	375	<10	0	<10	0	NA	NA	7350	2	NA	NA	49	0
8-Sep-11	16:20	1	Vibratory (Soft Start)	5161	<10	0	<10	0	NA	NA	7350	1	NA	NA	49	0
10-Sep-11	10:46	1	Vibratory (Soft Start)	116	<10	0	<10	0	NA	NA	9550	2	NA	NA	123	0*
10-Sep-11	10:47	1	Vibratory (Soft Start)	6227	<10	0	<10	0	NA	NA	9550	1	NA	NA	123	0
10-Sep-11	10:49	1	Vibratory (Soft Start)	216	<10	0	<10	0	NA	NA	9550	1	NA	NA	123	0

Sighting Date	Sighting Time (hh:mm)	Number of Individuals	Pile Driving Type	Actual Distance from Animal(s) to Pile (m)	190 dB RMS		180 dB RMS		160 dB RMS		120 dB RMS		100 dB RMS		90 dB RMS	
					Distance (m) to Threshold	Take	Distance (m) to Threshold	Take	Distance (m) to Threshold	Take	Distance (m) to Threshold	Take	Distance (m) to Threshold	Take	Distance (m) to Threshold	Take
<b>Harbor Seal (continued)</b>																
10-Sep-11	10:54	1	Vibratory	6317	<10	0	<10	0	NA	NA	9550	1	NA	NA	123	0
15-Sep-11	14:23	1	Impact (Soft Start)	975	10	0	20	0	500	0	NA	NA	NA	NA	189	0
15-Sep-11	14:25	1	Impact (Soft Start)	894	10	0	20	0	500	0	NA	NA	NA	NA	189	0
16-Sep-11	15:03	1	Impact (Soft Start)	54	10	0	<10	0	800	2	NA	NA	NA	NA	233	0*
16-Sep-11	15:05	2	Impact (Soft Start)	1084	10	0	<10	0	800	0	NA	NA	NA	NA	233	0
17-Sep-11	14:04	1	Vibratory (Soft Start)	182	<10	0	<10	0	NA	NA	10250	1	NA	NA	49	0
17-Sep-11	14:04	1	Vibratory	167	<10	0	<10	0	NA	NA	10250	1	NA	NA	46	0
17-Sep-11	15:38	1	Vibratory	165	<10	0	<10	0	NA	NA	8700	1	NA	NA	65	0
21-Sep-11	10:10	1	Impact (Soft Start)	50	10	0	200	0	775	2	NA	NA	NA	NA	164	0*
21-Sep-11	10:12	1	Impact (Soft Start)	1312	10	0	200	0	775	0	NA	NA	NA	NA	164	0
21-Sep-11	10:14	1	Impact (Soft Start)	365	10	0	200	0	775	1	NA	NA	NA	NA	164	0
21-Sep-11	10:18	1	Impact (Soft Start)	1554	10	0	200	0	775	0	NA	NA	NA	NA	164	0
21-Sep-11	10:19	1	Impact (Soft Start)	906	10	0	200	0	775	0	NA	NA	NA	NA	164	0
21-Sep-11	13:43	1	Vibratory	99	<10	0	<10	0	NA	NA	6250	2	NA	NA	101	0*
23-Sep-11	11:21	1	Vibratory (Soft Start)	106	<10	0	<10	0	NA	NA	7700	1	NA	NA	101	0
23-Sep-11	15:37	1	Vibratory (Soft Start)	785	<10	0	<10	0	NA	NA	6000	1	NA	NA	123	0
24-Sep-11	14:49	1	Vibratory	2220	<10	0	<10	0	NA	NA	2100	0	NA	NA	61	0
24-Sep-11	16:09	1	Vibratory	1664	<10	0	<10	0	NA	NA	2500	1	NA	NA	50	0
24-Sep-11	16:16	1	Vibratory	1591	<10	0	<10	0	NA	NA	2500	1	NA	NA	50	0
29-Sep-11	11:25	1	Vibratory	291	<10	0	<10	0	NA	NA	NA	NA	NA	NA	64	0
29-Sep-11	11:28	2	Vibratory	107	<10	0	<10	0	NA	NA	NA	NA	NA	NA	64	0
29-Sep-11	15:09	1	Impact (Soft Start)	1485	20	0	100	0	100	0	NA	NA	NA	NA	94	0
30-Sep-11	9:54	1	Impact (Soft Start)	1019	10	0	100	0	700	0	NA	NA	NA	NA	94	0
30-Sep-11	10:45	1	Vibratory	5938	<10		<10	0	NA	NA	3000	0	NA	NA	74	0

Sighting Date	Sighting Time (hh:mm)	Number of Individuals	Pile Driving Type	Actual Distance from Animal(s) to Pile (m)	190 dB RMS		180 dB RMS		160 dB RMS		120 dB RMS		100 dB RMS		90 dB RMS	
					Distance (m) to Threshold	Take	Distance (m) to Threshold	Take	Distance (m) to Threshold	Take	Distance (m) to Threshold	Take	Distance (m) to Threshold	Take	Distance (m) to Threshold	Take
<b>Harbor Seal (continued)</b>																
30-Sep-11	10:53	2	Vibratory	111	<10	0	<10	0	NA	NA	3000	2	NA	NA	74	0
30-Sep-11	10:55	2	Vibratory	1581	<10	0	<10	0	NA	NA	3000	2	NA	NA	74	0
30-Sep-11	13:36	1	Impact (Soft Start)	219	10	0	120	0	2900	1	NA	NA	NA	NA	134	0
1-Oct-11	14:09	1	Impact (Soft Start)	139	20	0	70	0	500	1	NA	NA	NA	NA	123	0
1-Oct-11	14:10	1	Impact (Soft Start)	93	20	0	70	0	500	2	NA	NA	NA	NA	123	0*
1-Oct-11	16:32	1	Impact	143	30	0	100	0	1500	2	NA	NA	NA	NA	159	0*
3-Oct-11	12:04	1	Impact (Soft Start)	128	10	0	120	0	1550	1	NA	NA	NA	NA	111	0
3-Oct-11	432:00	1	Vibratory	153	<10	0	<10	0	NA	NA	3700	1	NA	NA	34	0
5-Oct-11	16:44	1	Vibratory	140	<10	0	<10	0	NA	NA	3500	1	NA	NA	123	0
17-Oct-11	16:18	1	Vibratory	116	<10	0	<10	0	NA	NA	7000	2	NA	NA	123	0*
18-Oct-11	11:24	1	Vibratory (Soft Start)	117	<10	0	<10	0	NA	NA	6000	2	NA	NA	123	0*
18-Oct-11	13:17	1	Vibratory	266	<10	0	<10	0	NA	NA	7000	1	NA	NA	123	0
19-Oct-11	8:31	1	Vibratory (Soft Start)	217	<10	0	<10	0	NA	NA	1400	1	NA	NA	123	0
19-Oct-11	14:40	1	Vibratory	302	<10	0	<10	0	NA	NA	1700	1	NA	NA	123	0
19-Oct-11	16:09	9	Vibratory	400	<10	0	<10	0	NA	NA	6000	9	NA	NA	123	0
20-Oct-11	8:41	4	Vibratory (Soft Start)	160	<10	0	<10	0	NA	NA	2500	4	NA	NA	123	0
20-Oct-11	8:47	1	Vibratory	231	<10	0	<10	0	NA	NA	2500	1	NA	NA	123	0
20-Oct-11	8:52	1	Vibratory	215	<10	0	<10	0	NA	NA	2500	1	NA	NA	123	0
20-Oct-11	10:46	2	Vibratory (Soft Start)	202	<10	0	<10	0	NA	NA	5100	2	NA	NA	123	0
20-Oct-11	10:57	1	Vibratory	177	<10	0	<10	0	NA	NA	5100	1	NA	NA	123	0
<b>Take Subtotal</b>						<b>0</b>				<b>12</b>		<b>71</b>		<b>0</b>		<b>0</b>
<b>Harbor Porpoise</b>																
30-Aug-11	14:49	2	Vibratory	2175	<10	0	10	0	NA	NA	5500	2	NA	NA	NA	NA
8-Sep-11	14:41	3	Vibratory	4120	<10	0	<10	0	NA	NA	2750	0	NA	NA	NA	NA
8-Sep-11	15:01	3	Vibratory	3498	<10	0	<10	0	NA	NA	2750	0	NA	NA	NA	NA
8-Sep-11	16:17	1	Vibratory (Soft Start)	5258	<10	0	<10	0	NA	NA	7350	1	NA	NA	NA	NA
10-Sep-11	13:03	2	Vibratory	7257	<10	0	<10	0	NA	NA	2750	0	NA	NA	NA	NA
15-Sep-11	14:26	2	Impact (Soft Start)	2227	NA	0	50	0	500	0	NA	NA	NA	NA	NA	NA
16-Sep-11	10:53	1	Impact	1475	NA	0	10	0	500	0	NA	NA	NA	NA	NA	NA



Sighting Date	Sighting Time (hh:mm)	Number of Individuals	Pile Driving Type	Actual Distance from Animal(s) to Pile (m)	190 dB RMS		180 dB RMS		160 dB RMS		120 dB RMS		100 dB RMS		90 dB RMS	
					Distance (m) to Threshold	Take	Distance (m) to Threshold	Take	Distance (m) to Threshold	Take	Distance (m) to Threshold	Take	Distance (m) to Threshold	Take	Distance (m) to Threshold	Take
<b>Harbor Porpoise (continued)</b>																
16-Sep-11	16:10	2	Impact (Soft Start)	1979	NA	0	150	0	1700	0	NA	NA	NA	NA	NA	NA
29-Sep-11	16:34	1	Vibratory	5745	<10	0	<10	0	NA	NA	1000	0	NA	NA	NA	NA
5-Oct-11	16:32	1	Vibratory	9897	<10	0	<10	0	NA	NA	3500	0	NA	NA	NA	NA
<b>Take Subtotal</b>								<b>0</b>			<b>0</b>		<b>3</b>		<b>0</b>	<b>0</b>
<b>Killer Whale</b>																
NA																
<b>Dall's Porpoise</b>																
NA																
<b>Steller Sea Lion</b>																
NA																

Key: NA = Not Applicable

\*Sighting did not represent an airborne take since the animal was observed underwater at some point during the pile driving event

***THIS PAGE INTENTIONALLY LEFT BLANK***

## APPENDIX H

### All Sightings During TPP Pile Driving and Non-Pile Driving Activities

	Sighting occurred when no construction was ongoing
	Sighting occurred during the 30-minute construction pre-watch
	Sighting occurred during construction activity
	Sighting occurred during the 30-minute construction post-watch

Date	Time Observation Initiated (hh:mm)	Time Observation Completed (hh:mm)	Latitude	Longitude	Sighting Time (hh:mm)	Species	# of Anim(s)	Const. Type	Est. Dist. (m)/ Dir. to Ani(s)*	Behavior Type	Est. Dist. to Pile (m)**	Weather Conditions	Beaufort	Notes
<b>Phase 1</b>														
29-Aug-11	09:05	15:53	47 45.00	122 43.54	09:03	HSEA	3	NA	15/S	DI, MI	250/S	OC	0-1	1 close to boat about 15m; 2 further away about 100m; end sighting at 09:05
29-Aug-11	09:00	15:53	47 45.02	122 43.48	09:03	HSEA	2	NA	75/E	SI	500	OC	1	Close together, Waypoint 004
29-Aug-11	09:00	15:53	47 47.05	122 43.39	09:10	HSEA	2	NA	40/E	SI, TR	300	OC	1	Slow sink, moving towards barge
29-Aug-11	09:05	15:53	47 45.13	122 43.41	09:16	HSEA	1	NA	200	LO, SI, MI	25	OC	1-2	Milling in the area all directions; last sited at 09:30
29-Aug-11	09:15	15:53	47 44.35	122 42.17	09:20	CASL	8	NA	400/NE	RE	3000	OC	1	On WRA perimeter (outside) marginal wharf-at south end
29-Aug-11	09:05	15:53	47 45.17	122 43.44	09:28	HSEA	1	NA	230/N	DI	210/SW	OC	0-1	End sighting at 09:33
29-Aug-11	09:05	15:53	47 45.13	122 43.41	09:33	HSEA	2	NA	200	LO, SI, MI, TR (away from barge)	15	OC	1-2	Milling in the area all directions; later swam away from barge (10:01); swam towards barge (10:15); last sited at 11:00
29-Aug-11	09:19	15:53	47 45.36	122 44.83	09:52	HPOR	2	NA	300/N	TR	2097	OC	1	Pile #1 coordinates 47 45.17, -122 43.35
29-Aug-11	09:00	15:53	47 45.23	122 43.33	09:57	HSEA	1	NA	10/E	SI	75	OC	1	Seen once then sank
29-Aug-11	11:38	15:53	47 45.25	122 42.92	10:06	HSEA	1	NA	25/N	MI	3000	OC	1	Milling about, first sighted during due log # coast guard boats in area
29-Aug-11	09:00	15:53	47 45.23	122 43.33	10:16	HSEA	1	NA	20/SW	SI	100	OC	1	Seen briefly
29-Aug-11	09:15	15:53	47 45.43	122 44.66	10:44	HSEA	2	NA	50/N	SW, DI	2400	OC	1	Mom and pup pair
29-Aug-11	09:19	15:53	47 45.35	122 44.18	10:53	HSEA	1	NA	100/N	LO, SI	1102	OC	2	
29-Aug-11	09:15	15:53	47 45.39	122 44.57	10:54	HSEA	1	NA	30/E	SW, SI	2400	OC	1	
29-Aug-11	09:19	15:53	47 45.49	122 44.12	10:58	HSEA	2	NA	25/SE	LO, SI	1166	OC	2	2 HSEA spaced apart 30m. One had its eyes closed appeared to be sleeping
29-Aug-11	09:00	15:53	47 43.12	122 43.33	10:58	HSEA	1	NA	180/NE	SI, MI	100	OC	1	Seals working near shore b/w pier south and EHW1, milling and making dives within 30m of shore, do not seem to be recruiting new animals, seen again 11:08, Waypoint 007
29-Aug-11	09:05	15:53	47 45.18	122 43.51	11:28	HSEA	1	NA	20/SE	LO, SI	140/NW	OC	1-2	Lost sighting at 11:30 about 15m from barge
29-Aug-11	09:00	15:53	47 43.12	122 43.33	11:32	HSEA	1	NA	20/S	SI, MI	120	OC	1	Next seen 11:36 75m southeast from boat 195m from pile

Date:	Time Observation Initiated: (hh:mm)	Time Observation Completed: (hh:mm)	Latitude	Longitude	Sighting Time (hh:mm)	Species	# of Anim(s)	Const. Type	Est. Dist. (m)/ Dir. to Ani(s)*	Behavior Type	Est. Dist. to Pile (m)**	Weather Conditions	Beaufort	Notes
29-Aug-11	11:38	15:53	47 46.41	122 43.13	11:46	HSEA	1	V	25/N	SL, DI	>2000	OC	1	Slapped the water and dove, likely hunting in area
29-Aug-11	09:15	15:53	47 44.62	122 44.70	11:51	HSEA	1	V	200/E	RE	2800	OC	1	Resting on surface, 12:15 still resting
29-Aug-11	09:00	15:53	47 43.12	122 43.33	11:55	HSEA	1	V	100/S	SI	210	OC	1	
29-Aug-11	09:05	15:53	47 45.13	122 43.41	12:00	HSEA	1	V		LO, SI	150	OC		
29-Aug-11	11:38	15:53	47 46.50	122 42.93	12:19	HSEA	1	V	100/SE	MI	>2000	OC	1	Milling, sighted in first 5min of vibration, no obvious behavior difference from pre-screening time
29-Aug-11	09:05	15:53	47 45.13	122 43.41	12:20	HSEA	2	V	50	TR	150	OC	1	Last sighted at 12:21
29-Aug-11	09:05	15:53	47 45.18	122 43.40	12:20	OTHR	1	V	1/N	UN	50/N	OC	1	11 cm stunned/dead pacific herring
29-Aug-11	09:19	15:53	47 45.37	122 43.93	12:22	HSEA	1	V	100/NNE	LO, SI	762	OC	1	12:14-12:25 vibratory pile driving on #1 pile
29-Aug-11	09:15	15:53	47 44.90	122 44.64	12:42	HSEA	1	V	150/E	RE	3000	OC	2	Resting on surface
29-Aug-11	09:05	15:53	47 45.13	122 43.41	12:45	HSEA	2	V	200	LO, SI	250	OC		After 13:05 the sighting was passed onto Shocker; 1 adult and 1 sub-adult
29-Aug-11	09:00	15:53	47 45.06	122 43.37	13:08	HSEA	1	NA	15/SE	SI, MI	75	OC	1	1 seal joined pair, sighted by Stephanie, use Waypoint 008, not added as new sighting as seem to be same animals general area, 13:50 3 seals still vis general area near shore
29-Aug-11	09:05	15:53			13:21	HSEA	2	NA	50	LO, SI	400	OC		
29-Aug-11	09:05	15:53	47 45.18	122 43.55	13:30	HSEA	1	NA	30/NE	TR(E), DI	145/NW (from barge)	OC	2	13:35 last sighting
29-Aug-11	11:38	15:53	47 46.50	122 43.80	13:43	HPOR	2	NA	150/SE	MI	>2000	OC	1	Animals sighted as we arrived on station
29-Aug-11	11:38	15:53	47 46.66	122 43.23	13:46	HSEA	1	NA	100/N	LO	>2000	OC	1	
29-Aug-11	11:38	15:53	47 47.01	122 43.48	13:51	HPOR	1	NA	100/N	MI	>2000	PC	1	
29-Aug-11	09:15	15:53	47 44.65	122 44.89	13:53	HPOR	2	NA	50/NE	TR	3000	PC	2	Heading north
29-Aug-11	09:19	15:53	47 45.29	122 44.09	14:01	HSEA	2	NA	200/SW	LO	1053	OC	1	Pile #2 coordinates 47 45.15, -122 43.42
29-Aug-11	11:38	15:53	47 46.87	122 42.73	14:06	HSEA	1	NA	200/W	LO	>2000	PC	1	LO and swam toward vessel, watching vessel then dove to the north
29-Aug-11	09:19	15:53	47 45.26	122 44.12	14:26	HSEA	1	NA	175/NE	LO	1053	OC	1	Pile #2 soft start commences at 15:08 full vibratory driving from 15:10-15:23
29-Aug-11	09:00	15:53	47 45.14	122 43.32	14:28	HSEA	1	NA	15/W	SI, LO, TR	80	OC	1	Now a second solo seal noted in are Waypoint 008, calling it Waypoint 009 (note Waypoint 009 renamed carc1, time 14:52 code "TR" south of boat ~130m from pile)
29-Aug-11	11:38	15:53	47 46.35	122 43.00	14:29	HPOR	3	NA	75/N	MI	>2000	PC	1	Surfaced near vessel but headed north
29-Aug-11	09:05	15:53	47 45.15	122 43.42	14:32	HSEA	2	NA	250	SL, LO, SI		OC	1-2	
29-Aug-11	11:38	15:53	47 46.30	122 42.96	14:50	HSEA	1	V	50/N	LO	>2000	PC	1	Next test pile GPS 47 45.15, -122 43.42 resight of sighting #9 at 15:06
29-Aug-11	11:38	15:53	47 46.25	122 42.92	15:07	HSEA	3	SSV	250/SE	HO	>2000	PC	1	3 animals on floating dock under pier one dove in upon noticing them

Date:	Time Observation Initiated: (hh:mm)	Time Observation Completed: (hh:mm)	Latitude	Longitude	Sighting Time (hh:mm)	Species	# of Anim(s)	Const. Type	Est. Dist. (m)/ Dir. to Ani(s)*	Behavior Type	Est. Dist. to Pile (m)**	Weather Conditions	Beaufort	Notes
29-Aug-11	09:05	15:53	47 45.15	122 43.42	15:08	HSEA	1	SSV	500	LO, SI	500	OC	0-2	7a was before vibe and 7b was during; last sited at 15:13
29-Aug-11	09:00	15:53	47 45.14	122 43.32	15:13	HSEA	2	V	70/SE	LO, TR, LO, CD, TR	125	OC	2	As soft start (SS) was ending and vibe beginning 2 seals surfaced together and continued swimming north ~ 15 m from shore, vibrator started and seals changed direction to travel south at a rapid pace along surface. Rapid retreat south called in by Streak MMO. Seals noted moving south beyond white anchor buoy (340m). Next seen at 15:30 returning north ~100m north of white near shore anchor buoy. This was just before crane ops (Tommy) asked to hit the pile to release vibrator. Vibrator apparently came free. A single seal surfaced in exclusion zone. I requested a delay. At 15:34 Swift MMO reported seeing 2 seals surface outside shut down zone and rapidly dive as barge skiff approached east side of barge. 15:39 single seal seen 40m from pile traveling southeast steady pace along surface. 15:48 seal seen to look around at surface travelling south and sink dive.
29-Aug-11	11:38	15:53	47 46.23	122 42.88	15:25	HSEA	1	V	100/E	LO	>2000	PC	1	Soft start at 15:05 local 47 46.24, -122 42.91 full power at 15:09 vibration: another seal approaching haul out dock
29-Aug-11	09:05	15:53	47 45.18	122 43.45	15:43	HSEA	1	V	7/N	SP, DI	100/N	OC	1	Under EHW pier southwestern side; last sited at 15:46
29-Aug-11	11:38	15:53	47 46.85	122 44.03	15:47	HPOR	2	V	75/N	MI	>2000	PC	2	15:23 finished pile Shanii location 47 46.23, -122 42.87
29-Aug-11	09:05	15:53			15:53	HSEA	1	NA	250	LO, SI	400	OC	1-2	
30-Aug-11	08:10	15:55	47 49.10	122 43.53	08:12	HSEA	3	NA	30/N	LO, MI, SI	500	OC	0	08:14 begin 30 pre-watch
30-Aug-11	08:26	15:56	47 45.00	122 43.53	08:27	HSEA	1	NA	150	LO	200	OC	0	
30-Aug-11	08:10	15:55	47 45.10	122 43.32	08:28	HSEA	1	NA	50/SE	LO, SI	200	OC	0	
30-Aug-11	08:26	15:56	47 45.00	122 43.53	08:35	HSEA	2	NA	150	LO	200	OC	0	
30-Aug-11	08:30	15:54	47 44.26	122 44.94	08:38	CASL	4	NA	800/NE	RE	2000	OC	2	On WRA perimeter (outside) at south end, at 09:59- no reaction to pile driving observed, all animals still on fence
30-Aug-11	08:23	16:30	47 45.31	122 45.29	08:38	HPOR	2	NA	200/E	TR	2150	OC	0	Slowly travelling north. While deploying acoustic raft on far east side of canal
30-Aug-11	08:26	15:56	47 45.00	122 43.53	08:38	HSEA	2	NA	100	LO	300	OC	0	
30-Aug-11	08:10	15:55	47 45.10	122 43.32	08:45	HSEA	1	NA	200/S	LO, SW, SI	250	OC	1	



Date:	Time Observation Initiated: (hh:mm)	Time Observation Completed: (hh:mm)	Latitude	Longitude	Sighting Time (hh:mm)	Species	# of Anim(s)	Const. Type	Est. Dist. (m)/ Dir. to Ani(s)*	Behavior Type	Est. Dist. to Pile (m)**	Weather Conditions	Beaufort	Notes
30-Aug-11	08:30	15:53	47 45.51	122 43.98	08:45	HSEA	1	NA	30/W	TR, DI	1500	PC	2	In transit to watch area, 8:51 on watch and in position
30-Aug-11	08:30	15:54	47 44.30	122 44.91	08:47	HSEA	1	NA	20/NE	SW, LO, DI	2100	OC	2	
30-Aug-11	08:26	15:56	47 45.00	122 43.53	08:48	HSEA	2	NA	50	LO	500	OC	0	
30-Aug-11	08:26	15:56	47 45.00	122 43.53	08:49	HSEA	1	NA	75	LO	550	OC	0	
30-Aug-11	08:26	15:56	47 45.00	122 43.53	08:51	HSEA	1	NA	100	SI	500	OC	0	
30-Aug-11	08:26	15:56	47 45.00	122 43.53	08:53	HSEA	1	NA	50	LO	500	OC	0	
30-Aug-11	08:30	15:53	47 46.38	122 43.39	08:53	HSEA	1	NA	75/N	LO, SI	3000	OC	1	
30-Aug-11	08:26	15:56	47 45.00	122 43.53	08:54	HSEA	1	NA	250	LO	500	OC	0	
30-Aug-11	08:14	15:55	47 45.14	122 43.38	09:00	HSEA	1	NA	250/S	SW, DI	75/S	OC	0-1	Last sighted 09:07; swimming in an easterly direction towards the barge
30-Aug-11	08:30	15:53	47 47.20	122 43.40	09:00	HPOR	1	NA	200/S	TR	3000	OC	1	
30-Aug-11	08:30	15:53	47 47.23	122 43.46	09:02	HPOR	1	NA	300/S	TR	3000	OC	1	
30-Aug-11	08:26	15:56			09:24	HSEA	1	V	200	LO	100	OC	0	
30-Aug-11	08:30	15:53	47 46.17	122 42.96	09:24	HSEA	1	V	50/N	LO, DI	2000	OC	1	
30-Aug-11	08:10	15:55	47 45.10	122 43.32	09:25	HSEA	5	V	140/SW	LO, MI, SI	70	OC	1	All 5 coming closer looking at our boat. Pile being put into place, seals seem to have split up. Several went north and at least 2 went south-the 5 were in a tight (~10m) circle. Then all dove and came up elsewhere. There was a clanking from the barge and when it went quiet they split up.
30-Aug-11	08:30	15:54	47 44.68	122 44.91	09:26	HSEA	1	V	500/NE	SW, DI	1500	OC	2	Animal heading east
30-Aug-11	08:14	15:55	47 45.15	122 43.38	09:27	HSEA	3	V	120/NE	SW, TR(NE)	100/NE	OC	0-1	1st sited 120m about 5m from bank moving away from the barge, lost sighting under EHW about 09:34
30-Aug-11	08:14	15:55	47 45.15	122 43.38	09:31	HSEA	1	V	78/SE	SW, TR(NE)	80/NE	OC	0-1	1st sited 78m about 5m from bank moving away from barge; lost sighting under EHW about 09:40
30-Aug-11	08:23	16:30	47 45.25	122 44.06	09:37	HSEA	2	V	80/NE	LO, DI	875	OC	1	
30-Aug-11	08:10	15:55	47 45.10	122 43.32	09:37	HSEA	3	V	150/SW	LO, SI, SW, MS, OT		OC	1	OT= mother/pup snout to snout muzzle nuzzle, noted single adult about 20m west of pair just prior to soft start (SS), first SS vibe begins 09:51 to 09:52, 1 HSEA seen swimming slowly away during 1 minute pause period, 1 HSEA seen 280m from pile, pair not seen since before SS start while 300m from pile
30-Aug-11					09:37	HSEA	3	V						
30-Aug-11					09:37	HSEA	3	V						
30-Aug-11	08:30	15:54	47 44.79	122 44.81	09:45	HSEA	1	V	200/N	SW, DI	1300	OC	1	Animal heading west

Date:	Time Observation Initiated: (hh:mm)	Time Observation Completed: (hh:mm)	Latitude	Longitude	Sighting Time (hh:mm)	Species	# of Anim(s)	Const. Type	Est. Dist. (m)/ Dir. to Ani(s)*	Behavior Type	Est. Dist. to Pile (m)**	Weather Conditions	Beaufort	Notes
30-Aug-11	08:14	15:55	47 45.14	122 43.40	09:59	HSEA	2	V	45/N	SW, TR (S-NW), DI, LO	200/N	OC	1	Originally traveling towards us then traveled northwest away from us much faster than normal; traveled northwest 400m last sited 10:04
30-Aug-11	08:30	15:53	47 46.36	122 42.95	10:00	HSEA	1	V	100/N	LO, FO	2000	OC	1	Soft start #1 9:51, Soft start #2 9:54, Soft start #3 9:56, vibe 9:59
30-Aug-11	08:23	16:30	47 45.77	122 43.78	10:12	HSEA	1	V	175/SW	DI	1448	OC	1	
30-Aug-11	08:23	16:30	47 45.69	122 43.85	10:18	HSEA	2	V	50/S	LO, DI	1200	OC	1	
30-Aug-11	08:30	15:53	47 46.71	122 42.95	10:18	HSEA	1	V	30/E	LO, TR	3000	OC	1	10:16 end of vibration start 30 minute post production watch, seal was sighted at alpha marker
30-Aug-11	08:30	15:54	47 45.09	122 44.47	10:18	HSEA	1	V	100/SE	SW, DI	1000	OC	1	Animal heading west
30-Aug-11	08:30	15:54	47 44.64	122 44.81	10:18	CASL	1	V	800/E	RE	2000	OC	1	On WRA fence perimeter (south), now 5 animals total on fence, at 13:30-5 animals still on fence
30-Aug-11	08:30	15:53	47 46.13	122 43.22	10:18	HSEA	1	V	75/S	LO, DI	1800	OC	1	10:42 commence vibration, 10:48 end of vibration, resume 30 minute post vibration survey
30-Aug-11	08:30	15:54	47 44.39	122 45.03	10:18	HSEA	1	V	50/SE	SW, DI	2200	OC	1	Animal heading east
30-Aug-11	08:14	15:55	47 45.15	122 43.39	10:50	HSEA	1	V	150/E	SW, TR(S)	75/E	OC	1	Traveling south; last sited on other side of barge at 10:56
30-Aug-11	08:10	15:55	47 45.10	122 43.32	10:54	HSEA	2	V	180/SW	SW, SI		OC	1	2 HSEA next seen swimming slowly away from vibration activity south towards marginal pier, note vibration ended at 10:48
30-Aug-11	08:23	16:30	47 44.94	122 44.32	11:02	HSEA	2	V	50/E	LO	900	OC	1	Our boat was heading back to shore when the seals popped up and looked at us. When we got to within 20m they sank.
30-Aug-11	08:10	15:55	47 45.10	122 43.32	11:04	HSEA	1	V	10/W	LO, SI	105	OC	1	Next sighted still swimming south at 11:10
30-Aug-11	08:14	15:55	47 45.17	122 43.45	11:08	HSEA	1	V	300/E	FO, SW, TR(N)	100	OC	1	Initial sighting of it eating after surfacing; seen traveling n then lost under EHW pier at 11:10
30-Aug-11	08:26	15:56	47 45.00	122 43.53	12:21	HSEA	1	NA	50	LO, SW	500	OC	0	
30-Aug-11	08:26	15:56	47 45.00	122 43.53	12:29	HSEA	1	NA	200	LO	700	OC	0	
30-Aug-11	08:10	15:55	47 45.10	122 43.32	12:36	HSEA	1	NA	70/SW	SW, SI	75	OC	1	Next sighted moving south near shore, 12:48 sighted 105m north of boat, 12:52 seen under EHW1
30-Aug-11	08:14	15:55	47 45.15	122 43.46	12:55	HSEA	2	V	116/NE	LO, SW	125/N	OC	1	1 adult and 1 sub-adult; initial sighting northwest corner of EHW pier; last sited 12:53 heading northeast
30-Aug-11	08:14	15:55	47 45.14	122 43.47	13:13	HSEA	1	V	148/SW	DI, SW	104/W	OC	1	Last sighted 13:15
30-Aug-11	08:14	15:55	47 45.14	122 43.51	13:32	HSEA	1	V	69/SW	DI, SW, TR(E)	215/W	OC	0-1	Swimming toward pile last sited 13:37
30-Aug-11	08:10	15:55	47 45.10	122 43.32	13:34	HSEA	1	V	40/SW	SW, SI	200	OC	1	Last seen 13:38
30-Aug-11	08:10	15:55	47 45.10	122 43.32	13:36	HSEA	1	V	12/E	SW, SI	180	OC	1	13:40 surfaced again, 14:08 begin pre-watch

Date:	Time Observation Initiated: (hh:mm)	Time Observation Completed: (hh:mm)	Latitude	Longitude	Sighting Time (hh:mm)	Species	# of Anim(s)	Const. Type	Est. Dist. (m)/ Dir. to Ani(s)*	Behavior Type	Est. Dist. to Pile (m)**	Weather Conditions	Beaufort	Notes
30-Aug-11	08:30	15:53	47 46.01	122 43.31	13:54	HPOR	2	NA	1000/W	TR	1500	OC	1	Headed for the dock 11:18 end of 30min post-vibration survey
30-Aug-11	08:30	15:53	47 46.51	122 43.68	14:03	HSEA	1	NA	125/S	MI, LO	3000	OC	1	
30-Aug-11	08:30	15:53	47 46.64	122 43.90	14:06	HSEA	1	NA	100/S	LO, SI	3000	OC	1	14:08 begin 30min pre-vibration production watch
30-Aug-11	08:10	15:55	47 45.10	122 43.32	14:08	HSEA	2	V	10/W	LO, RE, SW, SI	110	OC	1	Mom and pup pair
30-Aug-11	08:10	15:55	47 45.10	122 43.32	14:08	HSEA	1	V	12/E	SW, LO, SI, MI	140	OC	1	Moving quickly southwest, 14:16 to 14:20 MI
30-Aug-11	08:26	15:56			14:17	HSEA	1	V	400	MI	600	OC	0	
30-Aug-11	08:10	15:55	47 45.03	122 43.38	14:24	HSEA	1	V	50/W	SW, HI	180	OC	1	14:39 begin SS, 14:47 vibrator on
30-Aug-11	08:10	15:55	47 45.03	122 43.38	14:24	HSEA	3	V	40/SW	SW, SI, OT	120	OC	1	Paired and single seal approaching along shore from south, OT=play/splashing
30-Aug-11	08:10	15:55	47 45.03	122 43.38	14:24	HSEA	1	V	18/N	SI, OT	120	OC	1	Mom and pup touching snouts, not looking at barges, end pile driving 14:55
30-Aug-11	08:23	16:30	47 45.22	122 44.16	14:27	HSEA	2	V	200/N	LO, SI	940	OC	1	Two seals 50m apart surfaced at the same time; pile #3 coordinates 47 45.07 - 122 43.42 soft start begins at 09:51 begin pile driving begins at 09:58-10:16.switching to bigger hammer. Resume pile driving 10:42-10:48; pile #4 coordinates 47 45. 11, -122 43.47. Pile # TPP 7 47 45.07, -122 43.48 start soft start at 14:39, start pile driving at 14:46-14:55. Resume at 14:57-15:01
30-Aug-11	08:30	15:53	47 45.99	122 43.57	14:49	HPOR	2	V	500/NNE	UN	1000	OC	1	Soft start #1 14:39, Soft start#2 14:42, Soft start#3 14:44, 14:46 pile commence vibrate , HPOR cow calf pair
30-Aug-11	08:14	15:55	47 45.12	122 43.39	14:51	HSEA	2	V	113/E	MI, DI, LO	200/E	OC	0-1	Initial sighting 10m from bank; sub-adult jumping over adult last sighting at 15:01
30-Aug-11	08:30	15:54	47 44.34	122 45.08	15:12	HPOR	2	V	600/E	TR	3000	PC	1	Animals heading south
30-Aug-11	08:30	15:54	47 44.24	122 45.13	15:17	HSEA	2	V	20/S	SW, LO, DI	2400	PC	1	Mom and pup pair, at 15:36 sighted again heading east
30-Aug-11	08:30	15:53	47 46.51	122 43.45	15:17	HPOR	4	V	50 & 200/W	TR	4000	OC	1	15:01 end pile drive, begin 30 minute post-production survey, sighting of 4 HPOR (2 cow calf pairs), 2 adults and two calves
30-Aug-11	08:30	15:53	47 46.14	122 43.74	15:25	HSEA	1	V	100/W	TR	2000	OC	1	
30-Aug-11	08:26	15:56	47 45.00	122 43.53	15:35	HSEA	1	NA	200	LO	750	OC	0	
30-Aug-11	08:30	15:54	47 44.00	122 45.18	15:37	HSEA	1	NA	50/N	SW, LO, SI	2400	PC	1	
30-Aug-11	08:30	15:53	47 45.95	122 43.57	15:39	HPOR	1	NA	100/SE	TR	1800	OC	1	15:53 end of watches for the day head for the dock
30-Aug-11	08:14	15:55	47 44.93	122 43.48	15:40	HSEA	1	NA	30/N	MI, DI	200/S	OC	0-1	Last sighting at 15:43
30-Aug-11	08:30	15:54	47 43.85	122 45.32	15:52	HSEA	1	NA	250/N	SW, SI	2800	PC	1	

Date:	Time Observation Initiated: (hh:mm)	Time Observation Completed: (hh:mm)	Latitude	Longitude	Sighting Time (hh:mm)	Species	# of Anim(s)	Const. Type	Est. Dist. (m)/ Dir. to Ani(s)*	Behavior Type	Est. Dist. to Pile (m)**	Weather Conditions	Beaufort	Notes
30-Aug-11	08:14	15:55	47 44.96	122 43.44	15:55	HSEA	2	NA	56/E	DI, SW	218/SE	OC	0-1	Last sighting 15:57
31-Aug-11	07:35	15:20	47 45.12	122 43.47	07:36	HSEA	1	NA	120/E	LO, SW, TR(N), DI	150/N	PC	1	1st sited about 20m from EHW lost under EHW; last sited at 07:39
31-Aug-11	07:35	15:20	47 45.12	122 43.47	07:38	HSEA	1	NA	100/N	LO, SW, TR(N), DI	250/N	PC	1	1st sited about 5-10m from bank and 10m from TPP1; lost under EHW; last sited 07:41
31-Aug-11	07:30	15:03	47 44.80	122 44.34	07:40	CASL	2	NA	125/N	RE, VO	1200	OC	2	2 CASL vocalizing hauled out on pen floats, noticed while in transit to watch area
31-Aug-11	07:35	15:20	47 45.12	122 43.47	07:44	HSEA	1	NA	115/S	LO, DI	60/from TPP3	PC	1	Last sighted 07:49
31-Aug-11	07:35	15:20	47 45.10	122 43.41	07:46	HSEA	2	NA	172/NE	LO, SW, TR(N)	250/N	PC	1	10m from TPP1 (07:50) lost under EHW 1 adult and 1 sub-adult; last sited 07:53
31-Aug-11	07:43	15:20	47 44.45	122 44.96	07:48	HPOR	1	NA	50/NE	MI	2500	PC	2	We were travelling to our hydrophone raft position
31-Aug-11	07:41	15:10	47 44.26	122 44.94	07:52	CASL	5	NA	1000/NE	RE	1800	PC	2	Hauled out on WRA perimeter fence (south end of delta pier)
31-Aug-11	07:41	15:10	47 44.32	122 44.90	07:54	HPOR	2	NA	20/E	TR, DI	2500	PC	2	Cow/calf pair-appear to be heading northeast
31-Aug-11	07:35	15:20	47 45.07	122 43.42	07:59	HSEA	1	NA	118/S	DI, SW, TR (NW)	15/original	PC	1	1st sited 15m from where pile will be; started heading northwest away from barge; last sited at 08:06
31-Aug-11	07:41	15:10	47 44.42	122 45.01	08:07	HSEA	1	NA	10/E	RE, SI	2500	PC	2	At 08:12-sank then resurfaced, at 08:59-still in area-same approx location, at 09:10-still at surface same general location
31-Aug-11	09:00	15:20	47 44.96	122 43.36	08:18	HSEA	1	NA	25/S	SW, SI	150	PC	1	8:22 surfaced swimming north ~125m from pile boom
31-Aug-11	07:35	15:02	47 45.00	122 43.53	08:26	HSEA	1	NA	150/S	LO	400	PC	1	
31-Aug-11	09:00	15:20	47 44.96	122 43.36	08:40	HSEA	1	NA	20/NE	SW, SI	140	PC	1	
31-Aug-11	07:43	15:20	47 45.32	122 44.17	08:42	HSEA	1	NA	75/NE	LO	1085	PC	1	
31-Aug-11	07:43	15:20	47 45.32	122 44.17	08:42	HPOR	2	NA	75/NE	TR	1085	PC	1	Porpoise sighting 3sec after seal sighting, the two species were separated by 30m, porpoise travelling towards seal
31-Aug-11	07:35	15:02	47 45.00	122 43.53	08:43	HSEA	1	NA	500	LO	500	PC	0	
31-Aug-11	07:35	15:02	47 45.00	122 43.53	08:43	HSEA	1	NA	500	LO	550	PC	0	
31-Aug-11	07:35	15:02	47 45.00	122 43.53	08:49	HSEA	1	V	550	LO	600	PC	0	Heading toward dock
31-Aug-11	07:30	15:03	47 45.08	122 43.85	08:58	HSEA	1	V	125/N	LO, SI	1800	PC	2	
31-Aug-11	07:35	15:02	47 45.00	122 43.53	09:08	HSEA	3	V	550/S	LO	600	PC	0	Last seen 120m from pile
31-Aug-11	09:00	15:20	47 44.96	122 43.36	09:10	HSEA	1	V	20/NE	SW, SI	125	PC	1	
31-Aug-11	07:35	15:02	47 45.00	122 43.53	09:11	HSEA	1	V	550/S	LO	600	PC	0	
31-Aug-11	07:41	15:10	47 45.03	122 44.89	09:13	HPOR	1	V	500/W	TR	2400	PC	1	Traveling north near shoreline
31-Aug-11	07:35	15:02	47 45.00	122 43.53	09:18	HSEA	1	V	100	LO	150	PC	1	
31-Aug-11	07:41	15:10	47 44.52	122 44.89	09:18	CASL	3	V	1000/E	RE	1800	PC	1	Total of 3 CASL now on perimeter fence, hauled out

Date:	Time Observation Initiated: (hh:mm)	Time Observation Completed: (hh:mm)	Latitude	Longitude	Sighting Time (hh:mm)	Species	# of Anim(s)	Const. Type	Est. Dist. (m)/ Dir. to Ani(s)*	Behavior Type	Est. Dist. to Pile (m)**	Weather Conditions	Beaufort	Notes
31-Aug-11	09:00	15:20	47 44.96	122 43.36	09:33	HSEA	1	V	40/W	SW, SI	80	PC	1	Sighted during pause in pile driving, resume pile driving 9:40
31-Aug-11	07:41	15:10	47 44.52	122 44.89	09:40	CASL	8	V	1000/E	RE				Begin pile driving-all 8 now hauled out on fence
31-Aug-11	09:00	15:20	47 44.96	122 43.36	09:42	HSEA	2	V	125/SW	SW, SI	140	PC	1	Hammer off 9:43 to 9:46, HSEA moving northwest perpendicular to barge, hammer resumed 9:46 and ended 9:57
31-Aug-11	07:35	15:20	47 45.07	122 43.42	09:46	HSEA	1	V	15/NE	DI, SW, TR(S)	125/N	PC	1	Last sighted 09:49
31-Aug-11	07:35	15:02	47 45.00	122 43.53	09:50	HSEA	1	V	500	LO	550	PC	1	
31-Aug-11	07:43	15:20	47 45.38	122 44.03	09:51	HSEA	2	V	125/SE	LO, TR	1021	PC	1	Travelling west, closest distance to boat 30m. LO, TR, LO, TR LO
31-Aug-11	09:00	15:20	47 44.96	122 43.36	10:00	HSEA	1	V	300/NE	SI	220	PC	1	Seen briefly ~20m offshore just 3 minutes after pile driving ended
31-Aug-11	09:00	15:20	47 44.96	122 43.36	10:02	HSEA	1	V	20/NE	SI	140	PC	1	
31-Aug-11	07:30	15:03	47 46.69	122 43.87	10:06	HSEA	2	V	300, 25/S	LO, SI	3000	PC	1	9:57 begin 30min post-vibratory survey
31-Aug-11	07:30	15:03	47 46.81	122 44.14	10:11	HSEA	1	V	100/S	TR	3000	PC	1	
31-Aug-11	07:41	15:10	47 45.19	122 44.48	10:15	HSEA	2	V	500/N	RE	1300	PC	1	No direction of travel detected
31-Aug-11	07:30	15:03	47 47.40	122 44.00	10:16	HPOR	1	V	500/E	TR	4000	PC	1	
31-Aug-11	07:43	15:20	47 45.15	122 44.29	10:17	HSEA	1	V	200/NE	LO, TR	1134	PC	1	Seal slowly travelling in west northwest direction
31-Aug-11	07:30	15:03	47 47.44	122 43.97	10:18	HSEA	1	V	100/S	TR, LO	4000	PC	1	
31-Aug-11	07:35	15:20	47 45.07	122 43.42	10:25	HSEA	1	V	25/SE (closest point)	DI, SW, TR(S)	50/S of TPP4	PC	0	Originally sited about 1m from tp1; about 50m from EHW; last sited at 10:31 after 30min post-watch lost it beyond 500m
31-Aug-11	07:30	15:03	47 47.77	122 43.06	10:27	HPOR	2	V	200/S	TR	5000	PC	1	
31-Aug-11	09:00	15:20	47 45.12	122 43.34	10:36	HSEA	1	NA	40/NE	FO, SI	300	PC	1	Eating a fish, began 30min watch 11:14, soft start begins 12:01, begin hammer 12:06, end hammer 12:13
31-Aug-11	07:43	15:20	47 45.51	122 44.09	10:38	HSEA	2	NA	250/ENE	LO, SI	1264	PC	0	
31-Aug-11	07:43	15:20	47 45.09	122 44.33	10:50	HSEA	2	NA	200/N	RE	1264	PC	0	Adult and juvenile resting on top of water
31-Aug-11	07:43	15:20	47 44.88	122 44.37	10:53	HSEA	3	NA	100/SE	LO	1166	PC	0	Travelling west, closest distance to boat 30m. LO, TR, LO, TR LO
31-Aug-11	07:43	15:20	47 45.01	122 44.31	10:57	HSEA	1	NA	75/N	LO, SI	1166	PC	0	2 seal looking with a third seal 20m to their west
31-Aug-11	07:30	15:03	47 46.11	122 43.59	11:02	HSEA	1	NA	100/SE	TR, LO, DI	1500	PC	1	11:15 on pre vibratory watch
31-Aug-11	07:35	15:20	47 45.07	122 43.47	11:15	HSEA	1	NA	82/N	DI, LO	282	PC	0	Heading north; last sighted at 11:29
31-Aug-11	07:43	15:20	47 45.06	122 44.31	11:16	HSEA	1	NA	100/S	LO, SI	1160	PC	0	
31-Aug-11	07:35	15:20	47 45.07	122 43.47	11:38	HSEA	1	V	30/E	DI, SW, TR(N)	160/E	PC	0	Moving north; last sighted at 11:40
31-Aug-11	07:35	15:20	47 45.07	122 43.47	11:41	HSEA	2	V	60/N	DI, LO	60/N	PC	0	1 adult and 1 sub-adult; hanging around within 50-75m of pile; 11:41-11:52 approaching marginal; last sighted 11:52



Date:	Time Observation Initiated: (hh:mm)	Time Observation Completed: (hh:mm)	Latitude	Longitude	Sighting Time (hh:mm)	Species	# of Anim(s)	Const. Type	Est. Dist. (m)/ Dir. to Ani(s)*	Behavior Type	Est. Dist. to Pile (m)**	Weather Conditions	Beaufort	Notes
31-Aug-11	07:35	15:02	47 44.96	122 43.71	11:46	HSEA	1	V	300	LO	500	PC	0	
31-Aug-11	07:35	15:02	47 44.96	122 43.71	11:49	HSEA	3	V	500	LO	800	PC	0	Outside of (west side) marginal wharf
31-Aug-11	07:35	15:20	47 45.07	122 43.47	11:50	HSEA	1	V	68/NE	DI, SW, TR(S then N)	75/NE	PC	0	Last sighted 11:55 200m northeast of pile
31-Aug-11	07:30	15:03	47 45.95	122 43.82	11:52	HSEA	1	V	50/S	LO, RE, SI	1500	PC	1	
31-Aug-11	07:35	15:02	47 44.96	122 43.71	11:55	HSEA	1	V	350	LO	800	PC	0	
31-Aug-11	07:35	15:02	47 44.96	122 43.71	11:57	HSEA	2	V	600/W	TR	900	PC	0	Outer part of WRA; midpoint between shore and barrier
31-Aug-11	07:41	15:10	47 44.52	122 44.89	11:58	CASL	8	V	1000/E	RE				8 CASL still hauled out on fence
31-Aug-11	07:35	15:02	47 44.96	122 43.71	12:01	HSEA	1	SSV	300/W	LO	700	PC	0	
31-Aug-11	07:41	15:10	47 44.52	122 44.89	12:02	CASL	1	SSV	1000/E	EW				1 of 8 CASL on fence entered water, was not obviously a result of piling activity
31-Aug-11	07:41	15:10	47 44.52	122 44.89	12:15	CASL	2	V	1000/E	RE				2 of 8 CASL visible on fence, hauled out
31-Aug-11	07:30	15:03	47 46.43	122 42.89	12:24	HSEA	1	V	25/S	LO, SW, SI	2000	PC	1	
31-Aug-11	07:41	15:10	47 44.52	122 44.89	12:25	CASL	3	V	1000/E	HO				3 CASL hauled out, total of 5 now visible again on fence, likely 5 of original 8
31-Aug-11	07:43	15:20	47 45.33	122 44.01	12:26	HSEA	1	V	100/W	TR	1200	PC	0	Seal traveling north our vessel travelling south
31-Aug-11	07:43	15:20	47 45.10	122 44.21	12:32	HSEA	1	V	30/W	VO, LO	800	PC	0	Seal pup looks and vocalizes one bark
31-Aug-11	07:30	15:03	47 46.99	122 43.95	12:38	HPOR	2	V	100/S	MI	5000	PC	1	12:45 wind from the north now scattered whitecaps with glare to the south b3+
31-Aug-11	07:35	15:20	47 45.07	122 43.47	12:40	HSEA	2	V	5/N (closest point)	DI, SW, TR(N, NW), FO	300/N	PC, S	0	1st sited about 15m southeast of EHW traveling towards tp13 last sighting behind barge (northwest side) 12:51
31-Aug-11	07:41	15:10	47 43.90	122 45.51	12:46	HSEA	1	NA	150/NW	RE	3000	PC	0	No direction of travel detected
31-Aug-11	07:43	15:20	47 45.01	122 44.32	12:48	HSEA	2	NA	30/E	TR	800	PC	0	
31-Aug-11	07:41	15:10	47 43.70	122 46.51	13:01	HSEA	1	NA	300/S	SW, DI	4000	PC	0	Near shoreline on west side of canal, direction of travel unknown
31-Aug-11	09:00	15:20	47 44.94	122 43.40	13:15	HSEA	1	NA	180/W	SW, SI, LO	15	PC	1	Swimming behind east end of barge at 13:25, 13:29 seen swimming towards marginal pier, 13:32 surfaced near pier
31-Aug-11	07:35	15:20	47 45.07	122 43.47	13:24	HSEA	2	NA	75/ENE	DI, SW, MI, LO	175/ENE	PC, S	2	Spotted 25m from TPP3; last sited 13:37
31-Aug-11	07:41	15:10	47 42.55	122 45.76	13:24	HSEA	1	NA	25/E	SW, DI	4000	PC	1	No direction of travel detected
31-Aug-11	07:43	15:20	47 45.33	122 44.09	13:49	HSEA	2	NA	125/E	LO, SL	956	PC	2	Two smaller seals looking and one of them slaps and dives both resurface later and look
31-Aug-11	09:00	15:20	47 44.94	122 43.40	13:52	HSEA	1	NA	80/SW	SW, SI	170	PC	1	Swimming south away from barge ops
31-Aug-11	07:35	15:02	47 44.96	122 43.71	13:54	HSEA	2	V	100/E	LO	700	S	2	Adult and pup/sub-adult 14:21 800m outside
31-Aug-11	07:35	15:02	47 44.96	122 43.71	13:59	HSEA	1	V	30/S	TR, LO	950	S	2	
31-Aug-11	07:43	15:20	47 45.23	122 44.14	14:06	HSEA	1	V	25/ENE	LO, SI	956	PC	2	

Date:	Time Observation Initiated: (hh:mm)	Time Observation Completed: (hh:mm)	Latitude	Longitude	Sighting Time (hh:mm)	Species	# of Anim(s)	Const. Type	Est. Dist. (m)/ Dir. to Ani(s)*	Behavior Type	Est. Dist. to Pile (m)**	Weather Conditions	Beaufort	Notes
31-Aug-11	09:00	15:20	47 44.94	122 43.40	14:07	HSEA	1	V	60/NE	SW, SI	160	PC	1	Last seen near marginal pier at 14:11
31-Aug-11	07:35	15:20	47 45.07	122 43.47	14:09	HSEA	1	V	75/ENE	SW, DI, LO	200/NE	PC, S	2	This individual joined up with sighting 33; last sighted at 14:27 fled the area during initial 30ft start beyond 200m; ended at 350m towards EHW
31-Aug-11	07:35	15:20	47 45.07	122 43.47	14:18	HSEA	1	V	75/ENE	SW, DI, LO	200/NE	PC, S	2	This individual joined up with sighting 32; last sighted at 14:27 fled the area during initial 30ft start beyond 200m; ended at 350m towards EHW
31-Aug-11	09:00	15:20	47 44.94	122 43.40	14:19	HSEA	1	V	20/NE	LO, SI	160	PC	1	SS begins 14:24
31-Aug-11	09:00	15:20	47 44.94	122 43.40	14:26	HSEA	1	SSV	70/NW	LO, SI	120	PC	1	14:28 start pile driving, HSEA first seen during soft start, then surfaced again closer to pile at 14:28 while hammer on, hammer off at 14:32, not seen again
31-Aug-11	07:43	15:20	47 45.15	122 44.17	14:27	HSEA	1	V	20/SE	LO, SI	875	PC	2	Surfaced with eyes closed kept eyes closed and sank
31-Aug-11	07:43	15:20	47 45.42	122 45.31	14:52	HSEA	1	V	25/W	LO, DI	2000	PC	1	One seal near acoustic raft as we pulled up to bring our raft back into the Ugly Duckling
31-Aug-11	07:35	15:20	47 45.07	122 43.47	14:53	HSEA	1	V	50/E	LO, SI	150/to TP12	PC, S	1	Last sighted 15:01
31-Aug-11	07:35	15:20	47 45.07	122 43.47	15:00	HSEA	1	V	110/E	DI	150/to TP12	PC, S	1	Last sighted 15:02
31-Aug-11	07:35	15:20	47 45.45	122 43.41	15:15	HSEA	1	NA	120/N	DI		S	1	Last sighted 15:23
31-Aug-11	07:35	15:20	47 45.45	122 43.41	15:20	HSEA	1	NA	250	SW, LO		S	1	Last sighted 15:23
1-Sep-11	07:50	16:22			07:50	HSEA	1	NA	30/S	LO, SI	600	F	0	At marginal dock
1-Sep-11	07:50	16:36	47 45.00	122 45.01	08:03	HPOR	3	NA	400/W	TR	2000	F	0	We were travelling to our acoustic raft position, 3 HPOR slowly travelling south. Fog is not on water. Can't see Construction crew barge
1-Sep-11	07:50	16:22	47 45.17	122 43.35	08:17	HSEA	2	NA	100/W	LO, SI	200	F	0	
1-Sep-11	08:00	16:30	47 44.67	122 44.45	08:40	CASL	3	NA	250/E	RE	1800	OC	1	Hauled out on WRA perimeter fence (south end of delta pier), at 10:22-10:23 visible on fence
1-Sep-11	07:50	16:22	47 45.21	122 43.48	08:45	HSEA	1	NA	100/NW	LO, SW, DI	280/NW	F	1	Last sighted 08:53 heading northwest
1-Sep-11	07:50	16:22	47 45.12	122 43.47	08:54	HSEA	1	NA	300/SW	DI, SW	480/SW	PC	1	Last sighted 08:56 heading southwest
1-Sep-11	08:00	16:30	47 44.94	122 44.23	08:55	HSEA	1	NA	30/N	SW, DI	1100	OC	1	No direction of travel detected
1-Sep-11	07:50	16:22	47 45.21	122 43.48	09:03	HSEA	1	NA	25/NE	DI, LO, SW	48/N	PC	1	Last sighted 09:10 heading n spotted again
1-Sep-11	07:50	16:25	47 45.12	122 43.41	09:15	HSEA	1	NA	110/E	SW	180	PC	1	
1-Sep-11	08:00	16:30	47 44.99	122 44.25	09:26	HSEA	1	NA	50/NE	SW, SI	1100	OC	1	No direction of travel detected
1-Sep-11	07:50	16:25	47 45.13	122 43.37	09:38	HSEA	1	NA	40/NE	SW, SI	100	PC	1	
1-Sep-11	07:50	16:25	47 45.13	122 43.37	09:46	HSEA	1	NA	220/S	SW, SI	300	PC	1	
1-Sep-11	07:50	16:36	47 45.20	122 44.15	09:53	HSEA	1	NA	20/W	RE	923	PC	1	Seal surfaced, with eyes closed, disappeared 30 seconds later

Date:	Time Observation Initiated: (hh:mm)	Time Observation Completed: (hh:mm)	Latitude	Longitude	Sighting Time (hh:mm)	Species	# of Anim(s)	Const. Type	Est. Dist. (m)/ Dir. to Ani(s)*	Behavior Type	Est. Dist. to Pile (m)**	Weather Conditions	Beaufort	Notes
1-Sep-11	07:50	16:25	47 45.13	122 43.37	09:55	HSEA	1	NA	150/SE	SW, LO	225	PC	1	
1-Sep-11	08:00	16:30	47 44.80	122 44.31	10:02	HSEA	1	NA	100/S	SW, SI	1200	PC	1	Animal heading east
1-Sep-11	08:00	16:23	47 45.47	122 44.02	10:34	HSEA	1	NA	25/E	TR, LO, SI	800	PC	2	Subadult, slow travel to the north, looks and sinks
1-Sep-11	07:50	16:22	47 45.04	122 43.27	10:47	HSEA	2	NA	50/S	LO, SI	700	S	1	Mom and pup pair
1-Sep-11	08:00	16:30	47 45.05	122 44.27	10:53	HSEA	1	NA	50/S	SW, SI	1150	PC	2	Animal heading east
1-Sep-11	08:00	16:30	47 44.75	122 44.57	11:03	CASL	1	I	600/SE	RE	1800	PC	2	Hauled out on perimeter fence-south end of delta pier, 4 CASL now visible on fence
1-Sep-11	07:50	16:25	47 45.13	122 43.37	11:04	HSEA	1	I	20/SW	SW, RE	125	PC	1	Note Streak MMO data (possibly 2 HSEA, HSEA surfaced when we were about 50m from pile), moving south, seen resting on surface with head up and slowly sinking at 11:19 near white stump, SS begin first hammer 11:30.03, second 11:36.18, third 11:37.07, SS should have ended 1 minute later (not announced), 11:39.06 final strike
1-Sep-11	07:50	16:25	47 45.07	122 43.48	11:44	HSEA	1	I	100/W	LO, SW, FO	300	PC	1	My impression was that just after end of pile driving multiple seals surfaced in the area within 550 m of pile 1 surfaced near marginal wharf. HSEA swam north at least briefly, I believe the others (and perhaps #44) converged at marginal wharf, note #46 still there at 12:06
1-Sep-11	07:50	16:25	47 45.07	122 43.48	11:44	HSEA	1	I	50/S	SW, LO, SI	200	PC	1	
1-Sep-11	07:50	16:22	47 45.04	122 43.27	11:46	HSEA	1	I	75/	RE, LO, SI	500	S	1	11:03, 11:14-resting at surface-only harbor seal
1-Sep-11	07:50	16:25	47 45.07	122 43.48	11:46	HSEA	1	I	200/SE	SW, SI	455	PC	1	
1-Sep-11	07:50	16:25	47 45.07	122 43.48	11:48	HSEA	1	I	350/SE	SW, SI	600	PC	1	Seen briefly by marginal wharf shore area
1-Sep-11	07:50	16:22	47 45.17	122 43.42	11:50	HSEA	1	I	10/SW	LO, SW, DI	111/SW	PC	0-1	Swam towards boat, headed north, west of EHW; spotted during 30min post-watch 11:39-12:09; last sited 11:59
1-Sep-11	08:00	16:30	47 44.67	122 44.78	11:54	CASL	4	I	600/E	RE	1800	PC	2	Total of 8 CASL now on perimeter fence, hauled out, south side of delta pier
1-Sep-11	08:00	16:30	47 44.58	122 44.83	12:32	CASL	2	NA	700/NE	RE	1800	PC	2	Now hauled out on WRA perimeter fence
1-Sep-11	07:50	16:36	47 45.34	122 44.34	12:38	HSEA	1	NA	25/E	LO, SI	1134	S	1	
1-Sep-11	08:00	16:30	47 44.48	122 45.68	12:52	HSEA	1	NA	800/S	RE, SW, SI	3200	PC	2	Near shoreline on west side of canal
1-Sep-11	08:00	16:30	47 44.55	122 45.56	13:00	HSEA	1	NA	50/N	SW, SI	2300	PC	2	No direction of travel detected
1-Sep-11	07:50	16:25	47 44.89	122 43.50	13:43	HSEA	1	NA	10/NE	SW, SI	600	PC	1	At marginal wharf while boats docked for fuel, last seen 13:45
1-Sep-11	07:50	16:25	47 44.89	122 43.50	14:06	HSEA	1	NA	10/NW	SW, SI	600	PC	1	Seal pup/juvenile at marginal wharf while boats parked for fuel

Date:	Time Observation Initiated: (hh:mm)	Time Observation Completed: (hh:mm)	Latitude	Longitude	Sighting Time (hh:mm)	Species	# of Anim(s)	Const. Type	Est. Dist. (m)/ Dir. to Ani(s)*	Behavior Type	Est. Dist. to Pile (m)**	Weather Conditions	Beaufort	Notes
1-Sep-11	07:50	16:36	47 45.43	122 44.18	14:26	HPOR	1	NA	400/WNW	TR	1037	S	0	Travelling ESE disappeared after 20 seconds
1-Sep-11	07:50	16:36	47 45.50	122 43.85	14:36	HSEA	1	NA	125/SE	TR, DI	891	S	1	
1-Sep-11	07:50	16:25	47 44.93	122 43.50	14:40	HSEA	1	NA	40/NW	SW, SI	400	PC	1	As we left marginal wharf HSEA seen swimming north along surface, begin 30 min watch at 14:45, HSEA seen again at 14:50 in exclusion zone (Exclusion Zone), 14:53 HSEA seen outside Exclusion Zone, 14:53 seen again outside Exclusion Zone, next seen 14:56 swimming south, all occurred near shore ~ half way between EHW1 and marginal wharf, same area where seal was sleeping or resting before (about 80m north of white stump on shore)
1-Sep-11	07:50	16:22	47 45.07	122 43.51	14:56	HSEA	1	NA	20/E	LO, SI	150/SW	S	1	Moved toward north-side of barge 15:10; last sighted 15:17
1-Sep-11	08:00	16:23	47 45.50	122 43.94	14:56	HPOR	1	NA	750/E	TR	1500	PC	1	1 adult
1-Sep-11	07:50	16:22	47 45.21	122 43.53	14:58	HSEA	1	NA	75/W	LO, SI	200/NW	S	1-2	Beaufort Scale changed from 1 to 2; resurfaced 15m from bank 400ft from pile during initial bubble (15:17) circled around to the bank; last sighted 15:29; might be a crossed with Shocker's
1-Sep-11	07:50	16:22	47 45.04	122 43.27	15:15	HSEA	1	I	100/	LO	500	S		
1-Sep-11	07:50	16:25	47 45.14	122 43.34	15:26	HSEA	1	I	200/NA	SW, SI	200	PC	1	
1-Sep-11	07:50	16:25	47 45.14	122 43.34	15:29	HSEA	2	I	80/N	LO, SI	110	PC	1	Seen by Celina and Hans, next seen ~15:33 by flagpole on EHW1 ~85m from pile, recorded pile strike times (db1 15:40:30, db2 15:42.16, db3 15:43.33, SS should have ended one minute later), 30 minute bubble curtain test began 15:45.14, end 15:46.01, start no bubble screen test 15:51.21 end 15:52.17, begin 30 minute post op survey 15:52, end 16:22
1-Sep-11	07:50	16:25	47 45.14	122 43.34	15:39	HSEA	1	I	50/NE	SW, SI, FO	120	PC	1	Both began moving south ~10m from shore about 50m apart, surfacing occasionally and looking around then sank, I believe seal #53 doubled back and was spotted by Streak MMO between shore and barge
1-Sep-11	07:50	16:25	47 45.14	122 43.34	15:39	HSEA	1	I	70/E	SW, LO, SI	140	PC	1	HSEA up again at 16:06
1-Sep-11	07:50	16:36	47 45.42	122 45.30	16:07	HSEA	1	I	25/SW	DI	2414	PC	1	Surfaced again 3min later 15m to the northwest at acoustic raft.
1-Sep-11	07:50	16:25	47 45.14	122 43.34	NA	HSEA	1	NA	300/SW	SW, SI	300	PC	1	
2-Sep-11	08:00	16:30	47 44.88	122 44.39	15:14	HSEA	1	NA	100/E	SW, SI	1100	PC	2	No direction of travel detected

Date:	Time Observation Initiated: (hh:mm)	Time Observation Completed: (hh:mm)	Latitude	Longitude	Sighting Time (hh:mm)	Species	# of Anim(s)	Const. Type	Est. Dist. (m)/ Dir. to Ani(s)*	Behavior Type	Est. Dist. to Pile (m)**	Weather Conditions	Beaufort	Notes
2-Sep-11	08:00	16:23	47 45.64	122 43.82	15:23	HPOR	2	NA	1000/E	TR	1500	PC	2	1 adult and 1 sub-adult
8-Sep-11	08:10	17:45	47 44.97	122 43.40	08:30	HSEA	2	NA	15980	SW, LO, SI, RE	NA	S	0	Stayed in area for hours, mother pup pair
8-Sep-11	08:30	17:29	47 45.00	122 43.53	08:38	HSEA	1	NA	151/300	LO, SI	20	S	0	Next to carder-rock pier
8-Sep-11	08:39	17:29	47 45.12	122 43.53	08:39	HSEA	1	NA	200/121	SI, SW	35 (to barge)	S	0	Saw for brief minute; last sited 08:40
8-Sep-11	08:10	17:45	47 45.47	122 43.34	08:39	HSEA	1	NA	232/327	SW, SI	NA	S	0	08:56 HSEA up again at 250m south of EHW1
8-Sep-11	08:39	17:29	47 45.15	122 43.54	08:53	HSEA	1	NA	155/210	SW (SW), SI, DI	200 (to barge)	S	0-1	Last sighted 08:55; resighted at 09:04 heading toward barge approximately 80m from barge heading ne; surfaced again at 09:07 50m from southwest corner of EHW1; approximately 30 degrees at 86m from us (47 45.14, -122 43. 48)
8-Sep-11	08:10	17:45	47 45.16	122 43.34	09:00	HSEA	2	NA	40/205	SW, SI	NA	S	0	Both seem to be hanging out in area 250m south of EHW1
8-Sep-11	08:39	17:29	47 45.14	122 43.48	09:16	HSEA	1	NA	70/30	SW, Si	120 (to barge)	S	0-1	
8-Sep-11	08:39	17:29	47 45.14	122 43.48	09:20	HSEA	2	NA	300	SW, SI	310 (to barge)	S	0-1	
8-Sep-11	08:39	17:29	47 45.13	122 43.50	09:36	HSEA	1	NA	80/19	SW, SI, DI	120 (to barge)	S	0-1	
8-Sep-11	08:30	17:29	47 45.58	122 43.96	09:42	HSEA	1	NA	175/185	LG	1000	S	1	Spotted 3 white and brown birds at carderrock pier
8-Sep-11	08:39	17:29	47 45.13	122 43.50	09:46	HSEA	3	NA	400/173	SW, SI	355 (to barge)	S	0-1	2 adults and 1 sub-adult
8-Sep-11	08:10	17:45	47 45.12	122 43.37	09:46	HSEA	1	NA	100/170	SW, SI	NA	S	0	
8-Sep-11	08:30	17:29	47 45.58	122 43.56	09:47	HSEA	1	NA	100/35	LO, SI	1200	S	1	
8-Sep-11	08:10	17:45	47 43.05	122 43.36	09:56	HSEA	1	NA	185/240	SW, SI	NA	S	0	
8-Sep-11	08:10	17:45	47 45.12	122 43.33	09:56	HSEA	1	NA	10/200	SI	NA	S	1	
8-Sep-11	08:30	17:29	47 46.49	122 43.63	09:57	HSEA	1	NA	100/45	LO, SI	2900	S	1	
8-Sep-11	08:55	17:30	47 45.14	122 43.50	09:59	HSEA	1	NA	150/200	SW, DI	100	S	1	Animal traveling south
8-Sep-11	09:06	17:40	47 45.60	122 43.89	10:06	HSEA	2	NA	100/251	LO, SI	901	S	1	
8-Sep-11	08:30	17:29	47 45.78	122 43.76	10:26	HSEA	1	NA	50/115	LO, SI	1500	S	1	Heading toward WRA
8-Sep-11	08:39	17:29	47 45.16	122 43.46	10:29	HSEA	1	NA	110/112	SW, SI, LO	110 (to barge)	S	0	Joined with 2 others that might be reported by Shocker
8-Sep-11	08:10	17:45	47 45.12	122 43.33	10:29	CASL	1	NA	210/225	SW, DI	NA	S	1	Headed south
8-Sep-11	08:10	17:45	47 45.12	122 43.33	10:29	HSEA	1	NA	15/245	SW, LO, SI	NA	S	1	Pair plus 1 or 2 HSEA stayed in area midway between marginal wharf and EHW1 all day
8-Sep-11	08:55	17:30	47 45.15	122 43.57	10:32	HSEA	1	NA	175/180	LO, SI	150	S	1	
8-Sep-11	08:30	17:29	47 44.50	122 44.91	10:32	HSEA	1	NA	20/10	RE, SI	2111	S	0	
8-Sep-11	08:39	17:29	47 45.16	122 43.46	10:37	HSEA	1	NA	56/280	LO, SI	210 (to barge)	S	0	10:40 last sited
8-Sep-11	08:30	17:29	47 44.70	122 44.71	10:44	HSEA	1	NA	70/93	TR, SI	1704	S	0	Heading north



Date:	Time Observation Initiated: (hh:mm)	Time Observation Completed: (hh:mm)	Latitude	Longitude	Sighting Time (hh:mm)	Species	# of Anim(s)	Const. Type	Est. Dist. (m)/ Dir. to Ani(s)*	Behavior Type	Est. Dist. to Pile (m)**	Weather Conditions	Beaufort	Notes
8-Sep-11	08:30	17:29	47 44.70	122 44.71	10:51	CASL	11	NA	600/103	RE, VO	1704	S	0	Sea lions are laying on floats along fence directly west of delta pier
8-Sep-11	08:39	17:29	47 45.14	122 43.50	11:02	HSEA	1	NA	20/29	LO, SW, SI	100 (to barge)	S	0	Last sighted at 11:13
8-Sep-11	08:30	17:29	47 45.58	122 43.00	11:02	HSEA	1	NA	200/280	SW	800	S	1	Swim north
8-Sep-11	08:55	17:30	47 45.12	122 43.54	11:08	HSEA	1	NA	300/180	LO, SW, SI	250	S	1	
8-Sep-11	08:55	17:30	47 45.13	122 43.54	11:17	HSEA	1	NA	200/135	LO, SW, DI	100	S	1	Swimming north toward barge
8-Sep-11	08:30	17:29	47 46.68	122 44.31	11:22	HSEA	1	NA	200/85	SW	3000	S	1	Swim south; 20-30 small white and brown birds in shore
8-Sep-11	08:30	17:29	47 43.76	122 45.85	11:45	HPOR	2	NA	75/63	TR	3889	S	0	Heading north
8-Sep-11	08:10	17:45	47 45.12	122 43.33	11:50	HSEA	1	NA	150/330	SW, SI	NA	S	1	Under EHW1
8-Sep-11	08:30	17:29	47 46.92	122 44.29	11:55	HPOR	3	NA	100/33	MI, FO	3700	S	1	8-9 rolls (surfaced); fish jumping
8-Sep-11	08:39	17:29	47 45.16	122 43.49	12:00	HSEA	2	NA	15/37	LO, SI, DI, MI	155 To TP3	S	0-1	12:43 2nd seal appears; first spotted at 12:00 has a black dot over right eye; the second seal came within 80m from pile at 12:58; last sited at 13:01
8-Sep-11	08:30	17:29	47 43.75	122 45.85	12:00	HSEA	2	NA	100/110	LO, SI	3889	S	0	
8-Sep-11	08:30	17:29	47 47.36	122 44.96	12:18	HPOR	1	NA	200/100	SW	4000	S	1	
8-Sep-11	08:30	17:29	47 47.25	122 44.11	12:55	HPOR	1	NA	150	SW	3800	S	1	1 roll (surface)
8-Sep-11	08:55	17:30	47 45.07	122 43.42	13:12	HSEA	1	NA	25/135	SW, LO, DI	100	S	1	Juvenile swimming north but out of exclusion zone
8-Sep-11	08:55	17:30	47 45.07	122 43.42	13:31	HSEA	1	NA	50/180	SW, LO, DI	100	S	1	Adult swim/dive headed south
8-Sep-11	08:10	17:45	47 45.12	122 43.33	13:51	HSEA	1	NA	30/20	SW, SI, RE	NA	S	1	
8-Sep-11	08:10	17:45	47 45.12	122 43.33	14:10	HSEA	1	V	40/200	SW	100	S	1	
8-Sep-11	08:55	17:30	47 45.07	122 43.42	14:29	HSEA	1	V	75/90	SW, LO, DI	150	S	1	Sub adult swimming south
8-Sep-11	08:55	17:30	47 45.07	122 43.42	14:34	HSEA	2	SSV	275/180	EW, DI	360	S	2	Pup hit the water quickly followed by adult
8-Sep-11	08:30	17:29	47 47.18	122 44.33	14:41	HPOR	3	V	150/10	SW	3950	S	1	4 rolls (surfaced); west towards shore; start of vibing
8-Sep-11	08:10	17:45	47 45.12	122 43.33	14:41	HSEA	1	V	25/260	SW, LO, SI	105	S	1	Swimming south between pile and Shocker, last seen at sighting time, no HSEA seen again after this last pile drive ops
8-Sep-11	08:30	17:29	47 46.97	122 44.37	14:41	HPOR	3	V	150/135	SW	3950	S	1	4 rolls (surfaced) swimming north; ending vibing
8-Sep-11	08:55	17:30	47 45.07	122 43.42	15:33	HSEA	1	V	250/180	LO, SI	350	S	2	
8-Sep-11	08:55	17:30	47 45.07	122 43.42	15:40	HSEA	2	V	275/135	LO, SW, SI, HO	375	S	2	Believe mom and pup back in same haul out area, haul out at 15:43
8-Sep-11	08:30	17:29	47 47.90	122 44.21	16:17	HPOR	1	SSV	30/50	SW	4000	S	1	4 rolls (surfaced); 2 west 2 east; seconds before soft start or at soft start

Date:	Time Observation Initiated: (hh:mm)	Time Observation Completed: (hh:mm)	Latitude	Longitude	Sighting Time (hh:mm)	Species	# of Anim(s)	Const. Type	Est. Dist. (m)/ Dir. to Ani(s)*	Behavior Type	Est. Dist. to Pile (m)**	Weather Conditions	Beaufort	Notes
8-Sep-11	08:55	17:30	47 45.07	122 43.42	16:20	HSEA	2	SSV	275/135	EW	375	S	2	Mom and pup pair from sighting #10 entered water during soft start
8-Sep-11	08:30	17:29	47 47.90	122 44.21	16:20	HSEA	1	SSV	100/135	LG, SI, LO	4000	S	1	Same animal at same GPS dist/direction to animal 50m/50; different location (47 47.88, -122 44.12); 200m/315 looking south
8-Sep-11	08:30	17:29	47 46.76	122 43.03	17:19	HSEA	1	V	50/205	LO, SI	1000	S	1	
8-Sep-11	09:06	17:40	47 45.31	122 45.12	17:21	HPOR	1	V	150/25	DI	2320	S	1	
10-Sep-11	07:21	17:27	47 44.31	122 44.52	08:07	HSEA	1	NA	300/35	SW	1000	S	0	Swimming toward WRA (east)
10-Sep-11	08:00	17:27	47 45.25	122 45.12	08:11	HPOR	2	NA	300/226	MI	2200	S	0	
10-Sep-11	07:21	17:27	47 46.66	122 43.73	08:11	HPOR	2	NA	500/25	SW, MI	2000	S	0	3 rolls (or surfaced) there is no code for this
10-Sep-11	08:15	17:32	47 44.92	122 43.56	08:20	HSEA	1	NA	100/0	LO, SI	300	S	1	Adult/ note to today's observation point. With the Silver Streak being out of use, I was positioned on marginal wharf at a set location, that is why lat/longs are all the same
10-Sep-11	08:15	17:32	47 44.92	122 43.56	08:25	HSEA	1	NA	100/45	LO, SI	275	S	1	Adult
10-Sep-11	07:21	17:27	47 47.63	122 42.65	08:29	HSEA	1	NA	50/240	SW	4000	S	1	Swimming south
10-Sep-11	08:19	17:32	47 45.16	122 43.45	08:31	HSEA	2	NA	300/330	RE, SI	360	S	1	
10-Sep-11	08:00	17:27	47 45.46	122 45.27	08:34	HSEA	1	NA	400/15	LO, SI	2300	S	0	
10-Sep-11	08:19	17:32	47 45.16	122 43.45	08:42	HSEA	1	NA	30/20	LO, SI	105	S	1	
10-Sep-11	08:19	17:37	47 45.18	122 43.53	08:55	CASL	1	NA	340/334	BR, SW, DI	400/330	S	1	Jumping and splashing; initial sighting was splashing; last sighting 09:00
10-Sep-11	08:19	17:32	47 45.07	122 43.40	09:03	HSEA	1	NA	12/295	SW, LO, SI	50	S	1	Inside 50m zone at 09:06, out of zone at 09:12. No active construction.
10-Sep-11	08:04	17:37	47 42.73	122 46.14	09:03	HSEA	1	NA	50/55	SP, DI	TP3-	S	0	
10-Sep-11	08:19	17:37	47 45.18	122 43.53	09:04	HSEA	2	NA	118/350	LO, SW	175	S	0-1	2nd individual joined at 09:09; last sited 09:47
10-Sep-11	08:00	17:27	47 45.63	122 44.07	09:11	HSEA	1	NA	125/90	TR	1100	S	0	
10-Sep-11	08:15	17:32	47 44.92	122 43.56	09:15	HSEA	1	NA	200/45	SW, DI	175	S	0	Adult
10-Sep-11	08:00	17:27	47 45.31	122 44.16	09:25	HSEA	1	NA	300/353	TR	949	S	0	
10-Sep-11	08:15	17:32	47 44.92	122 43.56	09:36	HSEA	1	NA	150/45	SW, LO, DI	225	S	0	Adult
10-Sep-11	08:19	17:37	47 45.18	122 43.53	09:40	HSEA	1	NA	75/62	MI, LO, DI	210	S	0-1	Last sighted 09:47
10-Sep-11	08:19	17:37	47 45.18	122 43.53	09:45	HSEA	1	NA	278/225	LO, SW, SI	387	S	0-1	Approximately 100m southeast of navy security boat; last sited at 09:47
10-Sep-11	07:21	17:27	47 48.99	122 41.40	09:45	HPOR	2	NA	20/60	SW	7800	S	3	SW south 2 rolls (surfaced)
10-Sep-11	08:15	17:32	47 44.92	122 43.56	09:50	HSEA	1	NA	300/340	SW, DI	125	S	1	Adult
10-Sep-11	08:19	17:37	47 45.18	122 43.53	09:52	HSEA	1	NA	100/264	LO, SW, SI	250	S	0-1	Last sighted 09:53
10-Sep-11	08:15	17:32	47 44.92	122 43.56	10:03	HSEA	2	NA	75/90	LO, DI	300	S	2	1 Adult and 1 sub-adult
10-Sep-11	08:04	17:37	47 42.85	122 45.84	10:06	HSEA	3	NA	75/30-60	UN, SP, DI	TP3-	S	0-1	3 seals with either just a head or head/body out of water no directional movement; fishing boat drove by scaring them on the water

Date:	Time Observation Initiated: (hh:mm)	Time Observation Completed: (hh:mm)	Latitude	Longitude	Sighting Time (hh:mm)	Species	# of Anim(s)	Const. Type	Est. Dist. (m)/ Dir. to Ani(s)*	Behavior Type	Est. Dist. to Pile (m)**	Weather Conditions	Beaufort	Notes
10-Sep-11	08:19	17:32	47 45.07	122 43.39	10:46	HSEA	1	SSV	172/270	SW, SI	80	S	1	
10-Sep-11	08:04	17:37	47 42.31	122 46.18	10:47	HSEA	1	SSV	25/155	SP	-	S	2-3	
10-Sep-11	08:19	17:32	47 45.07	122 43.39	10:49	HSEA	1	SSV	270/260	SW	120	S	2	HSEA moved away during soft start and not seen again
10-Sep-11	08:04	17:37	47 42.27	122 46.28	10:54	HSEA	1	V	25/90	SP, DI	-	S	2-3	10:54 dove about 5 sec after vibrate started
10-Sep-11	07:21	17:27	47 48.84	122 41.99	11:02	HSEA	1	V	80/35	LO, SI	7200	S	3	This occurred 3sec after vibrate
10-Sep-11	08:04	17:37	47 42.22	122 46.35	11:20	HSEA	1	V	10/355	SP	-	S	3	
10-Sep-11	08:19	17:32	47 45.07	122 43.39	11:29	HSEA	1	V	100/262	SW, SI	100	S	2	
10-Sep-11	08:19	17:32	47 45.07	122 43.39	11:32	HSEA	1	NA	20/20	SW, SI	130	S	2	
10-Sep-11	08:04	17:37	47 43.51	122 46.45	11:57	HSEA	1	NA	50/285	SP	4815	S	3	TP2
10-Sep-11	08:19	17:32	47 45.07	122 43.39	12:02	HSEA	1	NA	15/30	SW, SI	118	S	2	
10-Sep-11	08:00	17:27	47 48.29	122 43.92	12:15	HSEA	1	NA	150/170	LO, SI	5954	S	2	
10-Sep-11	08:19	17:32	47 45.11	122 43.36	12:38	HSEA	1	V	120/340	SW, SI	120	S	2	
10-Sep-11	08:04	17:37	47 42.68	122 46.40	12:39	HPOR	1	V	300/100	DI	5815	S	3	Headed south; appeared to be staying in one place. 5 dives then not seen again
10-Sep-11	08:15	17:32	47 44.92	122 43.56	12:41	HSEA	1	V	100/120	SW, DI	400	S	2	Adult
10-Sep-11	08:19	17:37	47 45.18	122 43.51	12:49	HSEA	1	V	90/70	SW, SI, LO	150	S	1	Last sighted 12:47
10-Sep-11	07:21	17:27	47 48.86	122 42.20	13:03	HPOR	2	V	185/37	CD, SW, CH	7300	S	2	Could hear them exhaling /breathing blows; 3 rolls (surfaced), 2 east, 1 west
10-Sep-11	07:21	17:27	47 45.74	122 43.41	13:33	HSEA	1	V	300/150	LO, SI	1000	S	1	Shani II coming in to tow Streak
10-Sep-11	08:15	17:32	47 44.92	122 43.56	13:35	HSEA	1	V	75/0	LO, SW, SI, MI	300	S	2	Adult
10-Sep-11	07:21	17:27	47 45.49	122 43.52	13:50	HPOR	2	NA	100/60	SW	680	S	1	8 rolls (surfaced) for one 2 rolls for second animal/heading northwest
10-Sep-11	08:19	17:32	47 45.12	122 43.37	14:04	HSEA	1	NA	130/236	SW, SI	60	S	2	
10-Sep-11	07:21	17:27	47 44.10	122 45.08	14:31	CASL	17	NA	700/40-60	HO	700	S	1	All hauled out spread out on middle of WRA fence
10-Sep-11	08:19	17:37	47 45.10	122 43.40	14:57	HSEA	1	NA	210/19	SW, LO, SI, MI	340	S	2	Sited next to TPP1 approximately 2m east of pile spotted it again northwest approximately 5m from TPP2 heading back towards EHW 15:01 last sited
10-Sep-11	07:21	17:27	47 43.67	122 44.66	15:13	HSEA	1	NA	60/75	SW, LO, SI	3000	S	1	Juvenile; SW toward shore 16:40; Shani II is docked at carderrock because of Streak down; LO, SI at 15:19; 15:21 15:48 SW 15:51, 15:57; so/SI 16:00, 16:03, 16:06, 16:08, 17:15 (SW)
10-Sep-11	08:04	17:37	47 42.50	122 46.66	15:17	HSEA	1	NA	10/105	SP	-	S	2	
10-Sep-11	08:19	17:37	47 45.11	122 43.36	15:28	HSEA	2	NA	106/146	SW, LO, SI, HO	215	S	2	1 adult and 1 sub-adult; hauled out on limbs similar location as Thursday's sighting (09/08/2011)
15-Sep-11	10:15	17:00	47 44.98	122 43.43	10:16	HSEA	2	NA	120/20	RE	320	OC	1	
15-Sep-11	10:15	17:00	47 45.08	122 43.38	10:35	HSEA	1	NA	15/270	LO, SI	120	OC	1	

Date:	Time Observation Initiated: (hh:mm)	Time Observation Completed: (hh:mm)	Latitude	Longitude	Sighting Time (hh:mm)	Species	# of Anim(s)	Const. Type	Est. Dist. (m)/ Dir. to Ani(s)*	Behavior Type	Est. Dist. to Pile (m)**	Weather Conditions	Beaufort	Notes
15-Sep-11	10:30	17:00	47 44.41	122 44.72	10:35	CASL	4	NA	1000/040-050	HO	1500	OC	1	Mary k. Watching them from her position. Just passed them
15-Sep-11	10:30	17:00	47 44.73	122 44.37	10:44	CASL	8	NA	400/E	RE	1800	OC	2	Hauled out on fence-south end of delta pier-not visible from our station
15-Sep-11	10:15	17:00	47 45.17	122 43.40	10:48	HSEA	1	NA	50/110	LO, SI	120	OC	1-2	
15-Sep-11	10:30	17:00	47 45.79	122 43.63	10:48	HSEA	1	NA	500/120	SW	1000	OC	1	SW toward WRA-heading south
15-Sep-11	10:30	17:00	47 45.91	122 43.54	10:53	HSEA	1	NA	800/150	LO	1500	OC	1	
15-Sep-11	09:15	17:00	47 46.07	122 43.42	10:58	HSEA	1	NA	75/132	LO, DI	125	OC	1	Between boat and shore swimming south
15-Sep-11	10:15	17:00	47 45.04	122 43.43	11:02	HSEA	1	NA	190/260	LO, SI	130	OC	1	
15-Sep-11	10:15	17:00	47 45.17	122 43.37	11:06	HSEA	1	NA	96/20	SW(N)	260	OC, L	1	Inside EHW1
15-Sep-11	10:30	17:00	47 45.75	122 43.73	11:30	HSEA	1	NA	1000/045	LO, SI	2500	OC	1	
15-Sep-11	10:30	17:00	47 45.87	122 43.72	11:42	HSEA	1	NA	500/020	LO, SI, SW	2000	OC	1	
15-Sep-11	09:15	17:00	47 45.07	122 43.42	11:44	HSEA	1	NA	75/135	LO, SI	165	OC	1	
15-Sep-11	09:15	17:00	47 45.07	122 43.42	12:01	HSEA	1	NA	100/130	LO, SI	165	OC	1	Swimming se toward shore
15-Sep-11	10:15	17:00	47 45.17	122 43.48	12:05	HSEA	1	NA	164/72	RE, SI	165	OC	1	
15-Sep-11	10:30	17:00	47 45.33	122 44.03	12:05	HSEA	1	NA	400/S	SW, DI	800	OC	2	Possibly heading east
15-Sep-11	10:15	17:00	47 45.16	122 43.48	12:26	HSEA	1	NA	233/96	SW(S), LO, SI	250	OC, L	1	
15-Sep-11	10:15	17:00	47 45.16	122 43.48	12:34	HSEA	1	NA	98/29	LO, SI, MI	180	OC, L	1	Approximately 2m from southwest corner of EHW1
15-Sep-11	10:15	17:00	47 45.16	122 43.48	12:48	HSEA	1	NA	240/342	LO, SI	350	OC, L	0-1	
15-Sep-11	10:30	17:00	47 44.16	122 44.07	13:15	HSEA	1	NA	250/W	RE, SI	1050	OC	1	Sank-no direction of travel detected
15-Sep-11	10:30	17:00	47 45.29	122 44.01	13:20	HSEA	1	NA	100/170	TR, SI	756	OC	1	Travelling at 36°
15-Sep-11	10:15	17:00	47 45.05	122 43.35	13:21	HSEA	1	NA	5/80	SW, SI	220	OC	1	Juvenile
15-Sep-11	10:30	17:00	47 44.91	122 44.36	13:29	HSEA	1	NA	400/S	RE, SI	1500	OC	1	No direction of travel detected but head pointing west when it sank
15-Sep-11	10:15	17:00	47 45.01	122 43.52	13:35	HSEA	1	NA	125/150	RE, SI	480	OC	1	Back by marginal wharf
15-Sep-11	10:30	17:00	47 45.78	122 43.49	13:35	HSEA	1	NA	300/080	SW, SI	1500	OC	0	
15-Sep-11	10:30	17:00	47 45.78	122 43.49	13:38	HPOR	1	NA	2000/355	SW	4500	OC, L	0	One roll (surface)-swimming east
15-Sep-11	10:30	17:00	47 45.79	122 43.47	13:43	HSEA	1	NA	100/045	LO, SI	1500	OC, L	0	Came up again at 13:47 and RE
15-Sep-11	10:15	17:00	47 45.13	122 43.38	13:46	HSEA	1	NA	200/210	LO, SI	45	OC, L	0-1	Sank within 1 min of sighting
15-Sep-11	10:30	17:00	47 45.25	122 44.20	13:49	HPOR	1	I	200/45	TR	949	OC	0	Travelling at 140°
15-Sep-11	10:30	17:00	47 45.81	122 43.44	13:50	HPOR	3	I	100/110	SW	1200	OC, L	0	Heading directly for WRA (south), five rolls (surfaced). Just prior to start of impact. Waited to clear the area
15-Sep-11	10:30	17:00	47 45.81	122 43.44	13:51	HSEA	1	I	50/160	SW	1200	OC, L	0	
15-Sep-11	10:30	17:00	47 44.98	122 44.31	13:52	HSEA	1	I	200/N	SW, DI	1000	OC	1	Heading east
15-Sep-11	10:15	17:00	47 45.16	122 43.58	13:57	HSEA	1	I	200/350	LO, SI, SW(E)	300/328	OC, L	0-1	Far north side of EHW1

Date:	Time Observation Initiated: (hh:mm)	Time Observation Completed: (hh:mm)	Latitude	Longitude	Sighting Time (hh:mm)	Species	# of Anim(s)	Const. Type	Est. Dist. (m)/ Dir. to Ani(s)*	Behavior Type	Est. Dist. to Pile (m)**	Weather Conditions	Beaufort	Notes
15-Sep-11	10:30	17:00	47 44.02	122 44.28	13:59	HSEA	1	I	250/E	SW, DI	650	OC	1	Heading east towards WRA fence, dove and did not see resurface
15-Sep-11	10:30	17:00	47 45.68	122 43.71	14:01	HSEA	1	I	50/180	LO, SI	1100	OC	0	
15-Sep-11	10:15	17:00	47 45.05	122 43.55	14:10	HSEA	1	I	50/280	SW, SI	135	OC	1	
15-Sep-11	10:30	17:00	47 45.17	122 44.04	14:23	HSEA	1	SSI	500/355	SW	1800	OC	1	Had to change positions because submarine was moving
15-Sep-11	10:30	17:00	47 45.33	122 44.16	14:25	HSEA	1	SSI	100/167	TR, DI	1031	OC	1	*Travelling at 250°, HSEA was seen after SS start but before impact driving was going full on. Construction crew had a series of 8 false starts ranging in time from 14:24:51 to 14:32:57
15-Sep-11	10:30	17:00	47 45.16	122 44.04	14:26	HPOR	2	SSI	1500/270	SW	2200	OC	1	2 rolls (surfaced), heading south
15-Sep-11	10:15	17:00	47 45.11	122 43.42	14:40	HSEA	1	I	160/222	LO, SI	192	OC	1	
15-Sep-11	10:30	17:00	47 45.67	122 43.09	14:53	HSEA	2	I	400/065	SW	1200	OC	0	Swimming north fairly quickly, 50m from shore. Post-observation.
15-Sep-11	10:15	17:00	47 45.06	122 43.36	14:54	HSEA	1	I	35/300	SW, SI	120	OC	1	
15-Sep-11	09:15	17:00	47 45.07	122 43.42	14:58	HSEA	1	I	200/180	SW, SI, CH	300	OC	1	Dive by TPP1 and chuffed before diving
15-Sep-11	10:15	17:00	47 45.01	122 43.38	15:17	HSEA	2	NA	178/170	SW, SI, LO, RE	305	OC	1	Mom and pup pair
15-Sep-11	10:15	17:00	47 45.01	122 43.39	15:19	HSEA	1	NA	200/205	SW, SI	400	OC	1	
15-Sep-11	10:30	17:00	47 45.17	122 44.03	15:23	HSEA	1	NA	500/358	TR	724	OC	1	Travelling at 258°
15-Sep-11	10:15	17:00	47 45.14	122 43.47	15:32	HSEA	1	NA	75/78	LO, SI	110	OC	0-1	
15-Sep-11	09:15	17:00	47 45.07	122 43.42	15:33	HSEA	1	NA	250/180	LO, SW, SI	300	OC	1	
15-Sep-11	10:15	17:00	47 45.14	122 43.47	15:42	HSEA	1	NA	120/345	LO, SI	185	OC	0-1	1 sub-adult
15-Sep-11	10:15	17:00	47 45.18	122 43.39	16:25	HSEA	1	NA	80/336	LO, SI	265	OC	0-1	Spotted under EHW1 pier, resighted 16:48 (47 45.13, -122 43.39)~210m from pile
15-Sep-11	10:30	17:00	47 45.36	122 44.07	16:26	HSEA	1	NA	150/320	LO, SI	1000	OC	1	
15-Sep-11	09:15	17:00	47 45.07	122 43.42	16:39	HSEA	1	NA	80/100	LO, DI	175	OC	1	
16-Sep-11	08:30	16:47	47 45.06	122 43.57	08:32	HSEA	1	NA	250/90	LO, SI	200	PC	0	
16-Sep-11	08:30	16:47	47 45.17	122 43.41	08:34	HSEA	1	NA	80/289	LO, SI	225	PC	0	Around green sign on southwestern corner of EHW1; small fish jumping within 1 m from seal; 08:40; 08:44 moved within 5m of TPP2
16-Sep-11	08:30	16:47	47 45.07	122 43.57	08:37	HSEA	1	NA	50/110	LO, SI	225	PC	0	
16-Sep-11	08:30	16:47	47 44.45	122 44.70	08:55	CASL	8	NA	450/E	RE	1800	PC	1	Hauled out on south end of delta pier WRA fence
16-Sep-11	08:30	16:47	47 45.13	122 43.52	09:02	HSEA	1	NA	407/24	LO, SI	75	PC	0	Sited on our 6
16-Sep-11	08:30	16:47	47 44.72	122 43.82	09:10	HSEA	1	NA	1200/085	LO	2500	OC	0	
16-Sep-11	08:30	16:47	47 45.04	122 43.53	09:13	HSEA	1	NA	8/300	LO, SI, FO	225	PC	0	
16-Sep-11	08:30	16:47	47 44.85	122 44.40	09:15	HSEA	1	NA	200/S	SW, LO, DI	1400	PC	1	Heading west



Date:	Time Observation Initiated: (hh:mm)	Time Observation Completed: (hh:mm)	Latitude	Longitude	Sighting Time (hh:mm)	Species	# of Anim(s)	Const. Type	Est. Dist. (m)/ Dir. to Ani(s)*	Behavior Type	Est. Dist. to Pile (m)**	Weather Conditions	Beaufort	Notes
16-Sep-11	08:30	16:47	47 45.07	122 43.42	09:17	HSEA	1	NA	25/210	SW, LO, DI	100	PC	0	
16-Sep-11	08:30	16:47	47 45.18	122 43.39	09:20	HSEA	2	NA	6/353	LO, SI, SW(NE)	217	PC	0-1	Adult under EHW1 pier and sub-adult following; while transecting 1 adult came within 5ft from boat
16-Sep-11	08:30	16:47	47 45.68	122 43.86	09:24	HSEA	1	NA	300/014	RE, SW, SI	1800	OC	0	
16-Sep-11	08:30	16:47	47 45.06	122 43.37	09:37	HSEA	1	NA	20/60	SW, SI	140	OC	0	
16-Sep-11	08:30	16:47	47 45.75	122 43.88	09:37	HPOR	2	NA	2000/000	SW	3000	OC	0	First animal rolled (surfaced) 5x, then second animal rolled (surfaced) twice, both of them rolled (surfaced) together. Swimming west. Then saw them at 9:45, 2000m at 25 degrees. Swimming east. Sightings at 10:11, 11:07 and 11:24. Each time they were swimming east.
16-Sep-11	08:30	16:47	47 45.78	122 43.73	09:40	HPOR	2	NA	500/002	SW	1700	OC	0	
16-Sep-11	08:30	16:47	47 45.88	122 43.81	09:45	HSEA	1	NA	2000/20	RE	3200	OC	0	
16-Sep-11	08:30	16:47	47 45.07	122 43.42	09:55	HSEA	1	NA	25/20	LO, DI	90	PC	0	
16-Sep-11	08:30	16:47	47 45.10	122 43.34	09:57	HSEA	1	NA	40/182	SW, SI	120	OC	0	
16-Sep-11	08:30	16:47	47 45.72	122 43.74	10:14	HSEA	1	I	200m/320	RE	1500	OC	0	10:28 resighted-RE, LO, SI
16-Sep-11	08:30	16:47	47 45.07	122 43.42	10:20	HSEA	1	I	75/210	SW, LO, DI	125	PC	0	
16-Sep-11	08:30	16:47	47 45.51	122 44.22	10:53	HPOR	1	I	300/285	TR	1126	PC	0	Travelling at 185°no reaction to impact
16-Sep-11	08:30	16:47	47 45.49	122 44.15	11:02	HSEA	1	I	100/S	SW, LO, DI	1100	PC	1	No direction of travel detected but sank with head facing west
16-Sep-11	08:30	16:47	47 45.93	122 43.69	11:05	HSEA	1	I	500/350	LO	1700	OC	0	
16-Sep-11	08:30	16:47	47 45.56	122 44.11	11:07	HSEA	1	I	150/NE	SW, LO, DI	1000	PC	1	Looking in multiple directions then sank-direction of travel unknown
16-Sep-11	08:30	16:47	47 45.16	122 43.44	11:09	HSEA	1	I	1/320	LO, SI, MI	85	PC	0	Spotted 5ft from our 6; surfaced again 4ft away at 11:11 been anchored since 11:07; potential pup (very, very small animal)
16-Sep-11	08:30	16:47	47 45.07	122 43.42	11:11	HSEA	1	I	75/65	SW, DI	150	PC	0	
16-Sep-11	08:30	16:47	47 45.13	122 44.33	11:20	HSEA	1	I	140/266	RE	1030	PC	1	Facing 002° resting on belly
16-Sep-11	08:30	16:47	47 45.16	122 43.44	11:22	HSEA	1	I	408/36	LO, SI	100	PC	0	
16-Sep-11	08:30	16:47	47 45.32	122 44.12	11:37	HSEA	1	NA	20/NE	SW, SI	900	PC	1	Heading south while swimming then sank
16-Sep-11	08:30	16:47	47 45.07	122 43.42	11:43	HSEA	1	NA	75/170	SW, LO, SI	175	PC	0	
16-Sep-11	08:30	16:47	47 45.16	122 43.44	11:46	HSEA	1	NA	110/188	LO, DI	45	PC	0	Surfaced then dove
16-Sep-11	08:30	16:47	47 45.07	122 43.42	11:55	HSEA	3	NA	25/90	SW, DI	125	S	1	
16-Sep-11	08:30	16:47	47 45.58	122 43.86	12:02	HSEA	3	NA	15/SE	SW, LO, SI	1000	PC	1	3 animals heading toward vessel looking then sank heading north, resurfaced on other side of vessel, looking then sank again
16-Sep-11	08:30	16:47	47 45.07	122 43.42	12:03	HSEA	1	NA	200/205	LO, SI	200	S	1	

Date:	Time Observation Initiated: (hh:mm)	Time Observation Completed: (hh:mm)	Latitude	Longitude	Sighting Time (hh:mm)	Species	# of Anim(s)	Const. Type	Est. Dist. (m)/ Dir. to Ani(s)*	Behavior Type	Est. Dist. to Pile (m)**	Weather Conditions	Beaufort	Notes
16-Sep-11	08:30	16:47	47 45.07	122 43.42	12:09	HSEA	1	NA	220/128	SW, DI	300	S	1	
16-Sep-11	08:30	16:47	47 45.67	122 43.75	12:13	HSEA	1	NA	150/112	LO, SI	1110	PC	1	
16-Sep-11	08:30	16:47	47 45.09	122 43.31	12:14	HSEA	1	NA	208/340	SW, SI	200	PC	1	
16-Sep-11	08:30	16:47	47 45.07	122 43.42	12:14	HSEA	2	NA	225/130	LO, SI	300	S	1	
16-Sep-11	08:30	16:47	47 45.16	122 43.44	12:15	HSEA	1	NA	120/301	LO, SW(N)	200	PC	0	
16-Sep-11	08:30	16:47	47 45.08	122 43.32	12:25	HSEA	2	NA	230/182	SW, SI	270	PC	1	
16-Sep-11	08:30	16:47	47 45.07	122 43.42	12:38	HSEA	1	NA	200/117	LO, SI	300	OC	1	
16-Sep-11	08:30	16:47	47 45.26	122 44.10	13:48	HSEA	1	NA	225/256	RE	925	OC	1	Facing 194° resting on belly
16-Sep-11	08:30	16:47	47 44.97	122 44.28	13:53	HSEA	1	NA	350/167	TR	1006	OC	1	Travelling towards security fence at 45°
16-Sep-11	08:30	16:47	47 45.49	122 43.73	14:02	HSEA	1	NA	20/110	SW, SI	750	OC	0	
16-Sep-11	08:30	16:47	47 44.78	122 44.52	14:07	HSEA	1	NA	300/SE	SW, SI	1100	PC	1	No direction of travel detected
16-Sep-11	08:30	16:47	47 45.17	122 43.43	14:11	HSEA	1	NA	70/301	LO, SI, RE	200	PC	0	1st sited with head up like a bobber
16-Sep-11	08:30	16:47	47 45.09	122 43.32	14:17	HSEA	1	NA	15/275	LO, RE, SI, SL	175	OC	0	
16-Sep-11	08:30	16:47	47 45.09	122 44.02	14:17	HSEA	1	NA	200/330	TR	675	OC	1	Travelling towards security fence at a heading of 137°
16-Sep-11	08:30	16:47	47 45.07	122 43.42	14:22	HSEA	1	NA	180/139	SW, LO, DI	225	OC	0	
16-Sep-11	08:30	16:47	47 45.26	122 44.10	14:25	HSEA	1	NA	80/075	LO, SI	758	OC	1	
16-Sep-11	08:30	16:47	47 45.07	122 43.42	14:33	HSEA	2	I	110/180	SW, LO, DI	200	PC	0	
16-Sep-11	08:30	16:47	47 45.57	122 43.58	14:34	HSEA	1	I	1500/265	SW	2700	OC	0	
16-Sep-11	08:30	16:47	47 45.57	122 43.54	14:38	HSEA	1	I	150/090	SW	850	OC	1	
16-Sep-11	08:30	16:47	47 44.97	122 44.28	14:46	HSEA	1	I	600/W	RE	1600	OC	1	Resting motionless at surface-no direction of travel
16-Sep-11	08:30	16:47	47 44.97	122 44.28	14:52	HSEA	1	I	800/SW	SW, DI	1800	OC	1	Headed west northwest
16-Sep-11	08:30	16:47	47 45.07	122 43.42	15:00	HSEA	1	I	100/15	SW, LO, DI	120	PC	0	
16-Sep-11	08:30	16:47	47 45.07	122 43.42	15:01	HSEA	1	I	40/10	SW, LO, DI	100	PC	0	
16-Sep-11	08:30	16:47	47 45.07	122 43.42	15:03	HSEA	1	SSI	100/355	SW, LO, DI	125	PC	0	Sighted during soft start specifically dead blow #2
16-Sep-11	08:30	16:47	47 45.52	122 43.63	15:05	HSEA	2	SSI	400/033	SW, SI	1180	OC	1	Swimming northwest 50m offshore
16-Sep-11	08:30	16:47	47 45.03	122 44.21	15:10	CASL	1	I	680/S	RE	1800	OC	1	Visible from our position during impact pile driving-one CASL likely from original animals seen on fence-visible during impact-no reaction observed
16-Sep-11	08:30	16:47	47 45.00	122 43.53	15:15	HSEA	4	I	130/200	LO, SW, MI	430	OC	0	
16-Sep-11	08:30	16:47	47 45.15	122 43.36	15:15	HSEA	1	I	30/160	LO, SI	200	OC	0-1	1st sited along beach and sank immediately

Date:	Time Observation Initiated: (hh:mm)	Time Observation Completed: (hh:mm)	Latitude	Longitude	Sighting Time (hh:mm)	Species	# of Anim(s)	Const. Type	Est. Dist. (m)/ Dir. to Ani(s)*	Behavior Type	Est. Dist. to Pile (m)**	Weather Conditions	Beaufort	Notes
16-Sep-11	08:30	16:47	47 45.51	122 42.65	15:26	HSEA	1	I	1000/015	RE, SW, SI	1780	OC	1	Post-ops observation
16-Sep-11	08:30	16:47	47 45.06	122 44.19	15:28	HSEA	1	I	20/E	LO, SI	885	OC	1	Resurfaced heading south, looked then sank again
16-Sep-11	08:30	16:47	47 45.07	122 44.18	15:40	HPOR	2	I	800/NW	TR, CD	1600	OC	1	2 animals initially sighted traveling north, these 2 individuals appeared to converge with 2 from id#68. ***general note: #67 and #68 converged (appeared to), changing direction (n/s) frequently-2 animals were observed moving quickly at surface then one porpoised as the other breached, another 2 animals were sighted further south (#69)-all animals continued moving n then s then n-changing direction frequently-they appeared to possibly be feeding. Lots of jumping fish were also observed in general area.
16-Sep-11	08:30	16:47	47 45.07	122 44.18	15:42	HPOR	2	I	500/W	TR, CD, PO	1500	OC	1	2 more animals initially sighted traveling south, these 2 appeared to join 2 from sighting id#67. ***general note: #67 and #68 converged (appeared to), changing direction (n/s) frequently-2 animals were observed moving quickly at surface then one porpoised as the other breached, another 2 animals were sighted further south (#69)-all animals continued moving n then s then n-changing direction frequently-they appeared to possibly be feeding. Lots of jumping fish were also observed in general area.
16-Sep-11	08:30	16:47	47 45.07	122 43.42	15:48	HSEA	1	I	50/110	LO, SI	140	PC	0	
16-Sep-11	08:30	16:47	47 45.07	122 43.42	15:53	HSEA	2	I	30/185	SW, LO, MI, DI	60	PC	0	
16-Sep-11	08:30	16:47	47 45.40	122 44.17	15:54	HSEA	1	I	125/252	TR, DI	1050	OC	0	Travelling at a heading of 058°
16-Sep-11	08:30	16:47	47 45.16	122 43.36	15:58	HSEA	1	I	20/15	LO, SI, DI, MI	205	OC	0-1	Last sighted at 16:03 hammer is on pile at 16:05
16-Sep-11	08:30	16:47	47 45.05	122 44.25	16:04	HPOR	2	I	800/SW	TR, CD	1800	OC	0	2 more sighted further south traveling in a northerly direction. ***general note: #67 and #68 converged (appeared to), changing direction (n/s) frequently-2 animals were observed moving quickly at surface then one porpoised as the other breached, another 2 animals were sighted further south (#69)-all animals continued moving n then s then n-changing direction frequently-they appeared to possibly be feeding. Lots of jumping fish were also observed in general area.

Date:	Time Observation Initiated: (hh:mm)	Time Observation Completed: (hh:mm)	Latitude	Longitude	Sighting Time (hh:mm)	Species	# of Anim(s)	Const. Type	Est. Dist. (m)/ Dir. to Ani(s)*	Behavior Type	Est. Dist. to Pile (m)**	Weather Conditions	Beaufort	Notes
16-Sep-11	08:30	16:47	47 45.39	122 44.16	16:07	HSEA	1	I	500/224	TR	1030	OC	0	Travelling at a heading of 010°
16-Sep-11	08:30	16:47	47 45.05	122 44.25	16:10	HPOR	2	SSI	1000/W	TR	2000	OC	0	2 animals visible during soft start, traveling north, not clear if 2 animals from id#67, 68 or 69. Animals were last sighted at approximately 16:15-no obvious behavioral changes observed during piling activity.
16-Sep-11	08:30	16:47	47 45.17	122 43.49	16:20	HSEA	1	I	300/208	SW(W)	225	OC	0-1	
16-Sep-11	08:30	16:47	47 46.05	122 44.39	16:24	HSEA	1	I	100/210	SW	1800	OC	0	Post-ops observation
16-Sep-11	08:30	16:47	47 46.08	122 44.42	16:24	HSEA	1	I	50/315	SW	1800	OC	0	Post-ops observation
16-Sep-11	08:30	16:47	47 45.16	122 43.46	16:25	HSEA	1	I	120/329	LO, SI, SW(E), RE	293	OC	0-1	Last sighted at 16:41 heading east
16-Sep-11	08:30	16:47	47 45.05	122 43.35	16:37	HSEA	1	I	40/205	SW, SI	310	OC	0	
16-Sep-11	08:30	16:47	47 45.16	122 43.46	16:40	HSEA	1	I	50/75	LO, SI, DI	129	OC	0-1	Last sighted at 16:43 heading south
16-Sep-11	08:30	16:47	47 44.98	122 44.25	16:40	HPOR	1	I	30/NW	TR, CD	1040	OC	0	Surfaced ~30m northwest of vessel, heading south-could not determine if this was one from previous groups but assume different animal, sighted again at 16:45 mid channel changing direction-possibly feeding
16-Sep-11	08:30	16:47	47 44.98	122 43.40	16:42	HSEA	1	I	160/320	SW, LO, SI	160	OC	0	
17-Sep-11	08:30	16:49	47 45.18	122 43.44	08:41	HSEA	1	NA	10/320	LO, SI	160	OC	2	Bubble curtain on at 10:11
17-Sep-11	08:30	16:49	47 44.53	122 44.71	09:31	CASL	1	NA	500/90	RE	1800	OC	4	On WRA fence-hauled out-south end of delta pier
17-Sep-11	08:30	16:49	47 44.53	122 44.71	09:32	CASL	1	NA	25/20	SW, LO	900	OC	4	Surfaced near boat, looked and continued swimming east towards WRA fence
17-Sep-11	08:30	16:49	47 45.14	122 43.38	09:50	HSEA	1	NA	30/243	LO, SI	100	OC	3	
17-Sep-11	08:30	16:49	47 45.16	122 43.47	10:22	HSEA	1	I	25/131	LO, SI	30	OC	2	Around bubbles swam south near storm 10:24; re-surfaced outside of zone (vibe was halted until seal was resighted outside of 50m)
17-Sep-11	08:30	16:49	47 45.12	122 43.36	10:56	HSEA	1	I	20/265	SW, LO, SI	115	L	2	Moving south
17-Sep-11	08:30	16:49	47 45.19	122 43.50	13:17	HSEA	1	NA	406/93	LO, SI, FO	150	OC	2	Caught fish around boat (looked like a salmon); then swam upside down under water; surfaced again with another fish 13:20; same area about 2ft from EHW1 (13:21)
17-Sep-11	08:30	16:49	47 45.20	122 43.51	13:40	HSEA	1	V	30/142	SW, SI	111	OC	2	Possibly previously sighted by Swift
17-Sep-11	08:30	16:49	47 45.20	122 43.50	14:04	HSEA	1	SSV	219/76	RE, SI	150	PC	2	When soft start happened (14:06) it dove immediately; resurfaced about 300m from TPP2 at 14:10 then dove; last sited 14:10
17-Sep-11	08:30	16:49	47 45.08	122 43.42	14:04	HSEA	1	V	75/105	SW, LO, SI	275	PC	3	Animal swimming slowly to south

Date:	Time Observation Initiated: (hh:mm)	Time Observation Completed: (hh:mm)	Latitude	Longitude	Sighting Time (hh:mm)	Species	# of Anim(s)	Const. Type	Est. Dist. (m)/ Dir. to Ani(s)*	Behavior Type	Est. Dist. to Pile (m)**	Weather Conditions	Beaufort	Notes
17-Sep-11	08:30	16:49	47 45.16	122 43.49	15:38	HSEA	1	V	170/117	LO, SI, SW(S)	179	PC	2	Heading south along bank last sited at 16:10
17-Sep-11	08:30	16:49	47 45.07	122 44.20	16:08	HSEA	1	V	20/265	LO, SI	879	PC	2	
17-Sep-11	08:30	16:49	47 44.93	122 44.25	16:10	CASL	13	V	750/140	RE, VO	1400	OC	3	Hauled out at delta pier on a vessel (sub), some animals were vocalizing
17-Sep-11	08:30	16:49	47 44.68	122 44.35	16:33	CASL	2	V	250/145	RE	1800	OC	3	Hauled out on delta pier fence (WRA) at south end
17-Sep-11	08:30	16:49	47 45.03	122 43.34	16:43	HSEA	1	V	85/240	SW, SI	100	OC	2	Position approximate
21-Sep-11	08:20	17:30	47 45.05	122 43.39	08:17	HSEA	2	NA	200/110	LO, SI	150	PC	0	
21-Sep-11	08:20	17:30	47 44.91	122 43.41	08:24	HSEA	1	NA	12/190	LO	NA	PC	1	2 HSEA inside 50m zone 08:43 out 08:43. No active construction
21-Sep-11	08:20	17:30	47 45.15	122 43.46	08:30	HSEA	1	NA	75/1	LO, SI, SW(N)	278	OC	1	Small individual about 1 m from southwest corner of EHW1 just below green sigh last sited 08:40
21-Sep-11	08:20	17:30	47 45.11	122 43.44	08:35	HSEA	1	NA	75/200	LO, SI, SW(N)	100	OC	1	Last sighted 08:40
21-Sep-11	08:20	17:30	47 45.51	122 43.78	08:42	HSEA	1	NA	150/215	LO	1000	OC	1	
21-Sep-11	08:20	17:30	47 45.44	122 45.29	08:54	HSEA	1	NA	250/163	RE	2204	OC	1	
21-Sep-11	08:20	17:30	47 45.01	122 43.36	08:58	HSEA	1	NA	30/200	SW, SI	140	OC	1	
21-Sep-11	08:20	17:30	47 44.91	122 44.19	08:59	CASL	11	NA	650/90	RE	1600	OC	1	9 hauled out on vessel at delta pier, 2 hauled out on WRA fence
21-Sep-11	08:20	17:30	47 45.42	122 45.24	09:00	HPOR	2	NA	50/001	SW	2150	OC	1	1 was smaller and they were heading 070°
21-Sep-11	08:20	17:30	47 45.12	122 43.34	09:06	HSEA	1	NA	259/324	LO, SI, SW(N)	350	OC	1	Last sighted 09:10
21-Sep-11	08:20	17:30	47 45.56	122 43.65	09:07	HSEA	1	NA	200/010	SW, LO, SI	1300	OC	1	9:12 LO, 9:19 LO
21-Sep-11	08:20	17:30	47 45.00	122 43.45	09:10	HSEA	1	NA	200/174	SW, SI	385	OC	1	
21-Sep-11	08:20	17:30	47 45.10	122 43.52	09:20	HSEA	1	NA	5/162	LO, SI	150	OC	1	Last sighted 09:21 sighted again 348m from boat near marginal at 09:26
21-Sep-11	08:20	17:30	47 44.97	122 43.48	09:25	HSEA	3	NA	190/197	MI, FO, RE, SI	175	OC	1	4th animal already recorded joined group feeding on large fish, not seen since storm sighting #4 11:10
21-Sep-11	08:20	17:30	47 45.60	122 43.55	09:30	HSEA	1	NA	600/15	LO, RE, SI	1600	OC	1	9:34 LO, 9:52 DI, 10:02 SW
21-Sep-11	08:20	17:30	47 45.00	122 43.45	09:35	CASL	1	NA	175/195		250	OC	0	
21-Sep-11	08:20	17:30	47 45.09	122 43.47	09:36	HSEA	1	NA	177/350	LO, SI, RE	210	OC	1	About 85m west of EHW1 southwest corner
21-Sep-11	08:20	17:30	47 45.00	122 43.54	09:47	HSEA	1	I	40/150	FO	200	OC	1	
21-Sep-11	08:20	17:30	47 45.00	122 43.45	09:55	HSEA	1	I	150/350	LO, SI	100	OC	0	
21-Sep-11	08:20	17:30	47 45.54	122 43.80	09:57	HSEA	1	I	325/091	SW	1000	OC	1	Up for 5min
21-Sep-11	08:20	17:30	47 45.01	122 43.45	10:10	HSEA	1	SSI	75/10	LO, SI	75	OC	0	Soft start #1

Date:	Time Observation Initiated: (hh:mm)	Time Observation Completed: (hh:mm)	Latitude	Longitude	Sighting Time (hh:mm)	Species	# of Anim(s)	Const. Type	Est. Dist. (m)/ Dir. to Ani(s)*	Behavior Type	Est. Dist. to Pile (m)**	Weather Conditions	Beaufort	Notes
21-Sep-11	08:20	17:30	47 45.62	122 43.67	10:12	HSEA	1	SSI	400/042	SW	900	OC	1	Swimming away (north) from WRA about 50 meters from shore
21-Sep-11	08:20	17:30	47 45.12	122 43.53	10:14	HSEA	1	SSI	310/221	LO, SI	450	OC	1	Heading southwest at 23; false start #2
21-Sep-11	08:20	17:30	47 45.61	122 43.68	10:18	HSEA	1	SSI	600/022	LO, DI	1500	OC	1	
21-Sep-11	08:20	17:30	47 45.16	122 44.14	10:19	HSEA	1	SSI	25/15	SW, SI	900	OC	1	Facing west when sank, animal was small juvenile, sighted between last false start and beginning of continuous impacting
21-Sep-11	08:20	17:30	47 45.09	122 43.31	10:46	HSEA	1	I	347/185	SI	320	PC	1	1st sighting since drive ended
21-Sep-11	08:20	17:30	47 45.09	122 43.43	11:14	HSEA	1	NA	50/210	LO, SI	100	PC	1	
21-Sep-11	08:20	17:30	47 45.09	122 43.31	11:26	HSEA	1	NA	35/195	SW, SI	NA	PC	1	
21-Sep-11	08:20	17:30	47 45.02	122 43.42	11:27	HSEA	1	NA	75/80	LO, SI	300	PC	1	
21-Sep-11	08:20	17:30	47 45.36	122 45.19	11:33	RIVO	6	NA	330/310	UN	2500	OC	2	River otter family on beach on west side of canal
21-Sep-11	08:20	17:30	47 45.36	122 45.19	11:52	HSEA	1	NA	60/219	RE	2270	PC	2	
21-Sep-11	08:20	17:30	47 45.14	122 43.55	12:00	HSEA	1	NA	20/150	LO, SI, SW(SE)	100	PC	1	Swimming toward barge last sited 12:02
21-Sep-11	08:20	17:30	47 45.62	122 43.59	12:27	HSEA	1	NA	100/150	LO, SI	900	OC	1	
21-Sep-11	08:20	17:30	47 44.48	122 44.91	12:59	HSEA	1	NA	400/270	RE	2400	PC	1	At surface resting, no direction of travel
21-Sep-11	08:20	17:30	47 45.36	122 45.22	13:10	HSEA	1	V	30/233	LO, SW, DI	2200	PC	1	
21-Sep-11	08:20	17:30	47 45.01	122 43.45	13:15	HSEA	1	V	60/100	SW, LO, DI	180	PC	1	
21-Sep-11	08:20	17:30	47 44.97	122 43.61	13:29	HSEA	1	V	120/120	SW, SI	200	PC	2	
21-Sep-11	08:20	17:30	47 45.05	122 43.80	13:33	HSEA	1	V	1000/020	LO, SI	2600	OC	1	13:00 LO, SI
21-Sep-11	08:20	17:30	47 44.98	122 43.59	13:43	HSEA	1	V	65/95	SW, SI	125	OC	2	During soft start between last soft start drive and begin drive
21-Sep-11	08:20	17:30	47 44.98	122 43.59	13:43	HSEA	1	V	65/95	TR, DI	~150	OC	2	Next seen during break in extraction and redrive (per storm)
21-Sep-11	08:20	17:30	47 45.01	122 43.45	13:49	HSEA	1	V	60/100	SW, LO, DI	180	OC	1	
21-Sep-11	08:20	17:30	47 46.40	122 43.72	14:20	HPOR	1	V	1000/010	SW	4000	OC	2	Swimming east, rolled (surfaced) 4 times
21-Sep-11	08:20	17:30	47 45.38	122 45.19	14:26	HSEA	1	V	50/344	LO, SI	2170	OC	2	
21-Sep-11	08:20	17:30	47 45.01	122 43.45	14:30	HSEA	1	V	110/165	SW, LO, DI	225	OC	1	
21-Sep-11	08:20	17:30	47 44.96	122 43.51	14:48	HSEA	1	V	65/184	SW, SI	205	OC	2	Joined previously sighted HSEA at marginal
21-Sep-11	08:20	17:30	47 44.93	122 43.42	15:19	HSEA	1	V	7/330	SW, DI	233	PC	1	Swimming rapidly south west at surface just after end vibe
21-Sep-11	08:20	17:30	47 44.96	122 43.45	16:09	HSEA	1	NA	15/146	SW, LO, SI	NA	PC	1	
21-Sep-11	08:20	17:30	47 44.92	122 43.46	16:32	HSEA	1	V	150/232	LO, SI	320	PC	1	Near project boat docking area
22-Sep-11	08:25	10:15	47 43.50	122 43.50	08:26	HSEA	1	NA	3/296	LO, SI		PC	1	



Date:	Time Observation Initiated: (hh:mm)	Time Observation Completed: (hh:mm)	Latitude	Longitude	Sighting Time (hh:mm)	Species	# of Anim(s)	Const. Type	Est. Dist. (m)/ Dir. to Ani(s)*	Behavior Type	Est. Dist. to Pile (m)**	Weather Conditions	Beaufort	Notes
22-Sep-11	08:25	10:15	47 43.41	122 43.41	09:47	HSEA	1	V	40/260	LO, SI		PC	1	In 30min. Post-drive watch, 09:53 seen at <50m from pile #8, 09:56 seen ~ 20m from pile 9 (just drove)=inside 50m zone, 09:59 LO, SI out 50m zone
22-Sep-11	08:25	16:01	47 45.13	122 43.61	09:59	HSEA	1	V	10/030	LO, DI	220	OC	4	Wind blowing hard, borderline bf 5
22-Sep-11	08:25	16:01	47 45.88	122 43.24	10:00	HSEA	1	NA	100/155	LO	2000	OC	3	
22-Sep-11	08:25	16:01	47 44.66	122 44.40	14:59	CASL	11	NA	300/100	RE	1600	OC	5	2 on fence 9 on vessels all hauled out.
22-Sep-11	14:40	16:01	47 44.99	122 43.43	15:58	HSEA	1	V	200/200	RE, SI		PC	1	Seal near shore between marginal parking & patrol boats, HSEA seen same are prior to Soft start
22-Sep-11	08:25	10:15	NA	NA	NA	NA	NA	NA	NA	NA	NA	NA	NA	Shut down of observations due to weather. B5 inside WRA and 5+ in hood canal. Zero sightings for today
23-Sep-11	08:17	16:51	47 45.14	122 43.53	08:21	HSEA	1	NA	20/220	SW, DI	140	PC	3	Small juvenile, direction of travel south
23-Sep-11	08:17	16:51	47 45.95	122 43.52	09:21	HSEA	1	V	25/005	LO, DI	150	PC	3	Heading 110°
23-Sep-11	08:17	16:51	47 46.36	122 42.87	09:49	HPOR	1	NA	100/149	CH, PO, SW	2500	S	3-4	Heard animal before got a visual. Three rolls. Swimming south toward WRA
23-Sep-11	08:17	16:51	47 45.22	122 43.64	10:09	CASL	1	NA	100/125	SW, DI	100	PC	4	Sighted just as it dove, appeared to be heading south
23-Sep-11	08:17	16:51	47 44.95	122 43.45	10:12	HSEA	1	NA	100/020	LO, SI	200	PC	2	Heading 110°
23-Sep-11	08:17	16:51	47 44.59	122 44.43	10:48	CASL	10	NA	100/75	RE	900	PC	5	4 CASL on fence +6 on subs
23-Sep-11	08:17	16:51	47 44.59	122 44.43	10:52	HSEA	1	V	35/290	TR, LO, DI	1900	PC	5	
23-Sep-11	08:17	16:51	47 45.16	122 43.47	10:53	HSEA	1	V	20/310	LO, SI	180	PC	4	Pup at 10:55 resurfaced ~10ft from stern looking
23-Sep-11	08:17	16:51	47 45.03	122 43.54	11:21	HSEA	1	SSV	40/280	LO, SI	110	PC	3	
23-Sep-11	08:17	16:51	47 45.07	122 43.42	11:45	HSEA	1	V	10/60	LO, SI	165	PC	4-5	Heading north; wind is blowing hard 11.0mph (average) to 23.0mph (max) with some spray
23-Sep-11	08:17	16:51	47 45.07	122 43.42	12:00	HSEA	1	V	12/250	LO, SI, SW (SW)	140	PC	4	Last sighted 12:06
23-Sep-11	08:17	16:51	47 44.47	122 44.46	12:04	HSEA	1	V	50/005	RE, LO, DI	1900	PC	5	Large adult
23-Sep-11	08:17	16:51	47 44.47	122 44.46	12:08	HSEA	1	V	50/010	RE	1900	PC	5	Sleeping/bobbing
23-Sep-11	08:17	16:51	47 44.36	122 44.70	12:19	HPOR	1	NA	40/350	SW	2000	PC	5	Waypoint 011, 1st one roll (surface) going ~225°, then seen by captain mike going ~010, inside yellow buoys or right on line
23-Sep-11	08:17	16:51	47 45.07	122 43.42	12:21	HSEA	1	NA	150/210	LO, SI	40	PC	4	Sighted just below the southeast corner guard 16.0mph (average wind) to 22.0mph (max)
23-Sep-11	08:17	16:51	47 45.07	122 43.46	13:01	HSEA	1	NA	408/80	LO, SI	130	PC	3	Heading north
23-Sep-11	08:17	16:51	47 45.07	122 43.53	13:10	HSEA	1	NA	80/005	LO, SI, FO	80	PC	3	Inside 50m zone
23-Sep-11	08:17	16:51	47 45.15	122 43.46	13:30	HSEA	1	NA	110/260	SW, SI	100	PC	4	Sank near barge, no direction of travel detected

Date:	Time Observation Initiated: (hh:mm)	Time Observation Completed: (hh:mm)	Latitude	Longitude	Sighting Time (hh:mm)	Species	# of Anim(s)	Const. Type	Est. Dist. (m)/ Dir. to Ani(s)*	Behavior Type	Est. Dist. to Pile (m)**	Weather Conditions	Beaufort	Notes
23-Sep-11	08:17	16:51	47 45.07	122 43.46	14:10	HSEA	1	NA	408/42	LO, SI, SW(E)	178	PC	3	Heading east
23-Sep-11	08:17	16:51	47 45.15	122 43.44	14:40	HSEA	1	NA	100/120	LO, SI	200	PC	4	Could be Dana (Shocker) sighting #5, no direction of travel observed
23-Sep-11	08:17	16:51	47 45.07	122 43.46	14:46	HSEA	1	NA	130/300	LO, SI	40	PC	3-4	
23-Sep-11	08:17	16:51	47 45.16	122 43.45	15:00	HSEA	1	NA	50/280	LO, SI	100	PC	3	Sank facing south but no direction of travel detected
23-Sep-11	08:17	16:51	47 45.01	122 44.17	15:37	HSEA	1	SSV	75/60	LO, SI	600	PC	5	8:45 strong b5, border on b6
23-Sep-11	08:17	16:51	47 45.15	122 43.44	16:25	HSEA	1	V	175/90	SW, DI	225	PC	3	Swimming south near shoreline
23-Sep-11	08:17	16:51	47 46.22	122 42.84	16:25	HSEA	1	V	150/150	LO, SI	2000	S	3-4	50m offshore
23-Sep-11	08:17	16:51	47 46.04	122 42.01	16:25	HSEA	1	V	100/170	DI	1500	S	3-4	50m offshore
24-Sep-11	08:38	16:45	47 45.09	122 43.54	08:42	HSEA	1	NA	110/30	LO, SI	200	S	1	Sank, no direction of travel detected
24-Sep-11	08:38	16:45	47 45.09	122 43.53	08:50	HSEA	1	NA	70/200	LO, SI	60	S	1	Sank facing south towards barge
24-Sep-11	08:38	16:45	47 44.80	122 44.40	09:00	CASL	15	NA	70/90	RE	NA	S	2	9 CASL on "packages", 6 on fence
24-Sep-11	08:38	16:45	47 46.95	122 43.76	09:10	HSEA	1	NA	75/355	LO, SI	3000	S	1	
24-Sep-11	08:38	15:45	47 40.04	122 46.51	09:18	HSEA	1	NA	100/076	LO, SI	1007	S	1	
24-Sep-11	08:38	16:45	47 45.11	122 43.32	09:21	HSEA	2	NA	25/180	LO, SI, SW(S), DI, MI	210	S	1	Milling about keeping an eye on Keith and the boat at 09:34; changed directions heading north toward EHW1; this individual was potentially spotted several times throughout the day hanging around the same area
24-Sep-11	08:38	16:45	47 48.18	122 44.11	09:23	HPOR	2	NA	100/190	TR, MI	4000	S	1	On far west side of hood canal, visible blows, good look at dorsal fins
24-Sep-11	08:38	16:45	47 45.03	122 43.22	09:31	HSEA	1	NA	100/290	LO, SI	150	S	1	Could be Paula's sighting (Swift)
24-Sep-11	08:38	16:45	47 45.07	122 43.42	10:01	HSEA	1	NA	130/135	SW, DI	200	S	1	Heading south near shoreline
24-Sep-11	08:38	16:45	47 44.98	122 43.48	10:32	HSEA	1	NA	50/273	LO, SI	150	S	1	
24-Sep-11	08:38	16:45	47 45.11	122 43.50	10:45	HSEA	1	NA	350/345	LO	450	S	1	
24-Sep-11	08:38	16:45	47 44.97	122 43.48	10:50	HSEA	1	NA	105/50	LO, SI	170	S	1	
24-Sep-11	08:38	16:45	47 44.97	122 43.48	10:51	HSEA	1	NA	100/180	LO, SI	210	S	1	Possibly Swift's sighting 108
24-Sep-11	08:38	16:45	47 45.08	122 43.42	10:54	HSEA	1	NA	75/30	SW, DI	250	S	1	Appeared to be traveling northwest, juvenile-may be same animal as Dana (Shocker) sighting #123
24-Sep-11	08:38	16:45	47 44.97	122 43.48	11:21	HSEA	1	NA	125/229	LO, DI	145	S	1	About 75m south of barge
24-Sep-11	08:38	16:45	47 45.11	122 43.51	11:26	HSEA	1	NA	450/350	LO, DI	550	S	1	11:42 DI
24-Sep-11	08:38	16:45	47 44.97	122 43.48	12:24	HSEA	1	NA	50/122	LO, SI, SW(S)	350	S	1	Could be one of the same individuals hugging the bank spotted again about 25m from marginal dock
24-Sep-11	08:38	16:45	47 44.97	122 43.48	12:30	HSEA	1	NA	75/90	LO, SI, SW(SE)	300	S	1	Could be one of the same individuals hugging the bank spotted again about 25m from marginal dock
24-Sep-11	08:38	16:45	47 44.97	122 43.48	12:47	HSEA	1	NA	20/24	SW(E), DI	140	S	1	

Date:	Time Observation Initiated: (hh:mm)	Time Observation Completed: (hh:mm)	Latitude	Longitude	Sighting Time (hh:mm)	Species	# of Anim(s)	Const. Type	Est. Dist. (m)/ Dir. to Ani(s)*	Behavior Type	Est. Dist. to Pile (m)**	Weather Conditions	Beaufort	Notes
24-Sep-11	08:38	16:45	47 45.09	122 43.48	12:48	HSEA	1	NA	100/190	LO, SI	60	S	1	Juvenile, most likely a previously sighted individual
24-Sep-11	08:38	16:45	47 45.74	122 43.78	12:50	HPOR	1	NA	500/45	TR	1500	PC	2	One animal traveling to the northwest
24-Sep-11	08:38	16:45	47 44.96	122 43.65	13:23	HSEA	1	NA	40/180	LO, DI, SW(E)	160	S	1	
24-Sep-11	08:38	16:45	47 44.99	122 43.51	13:34	HSEA	1	NA	75/160	LO, SI	200	PC	1	Bubble curtain before the impact began
24-Sep-11	08:38	16:45	47 45.01	122 43.45	13:52	HSEA	1	I	150/160	LO, SI	300	S	1	
24-Sep-11	08:38	16:45	47 45.01	122 43.45	13:54	HSEA	1	I	400/198	LO, DI	500	S	1	
24-Sep-11	08:38	16:45	47 45.97	122 43.59	14:16	HSEA	1	I	20/200	LO, SI	120	PC	2	
24-Sep-11	08:38	15:45	47 45.34	122 45.19	14:49	HSEA	1	V	125/233	LO, DI	2160	PC	2	Heading 350°
24-Sep-11	08:38	16:45	47 45.09	122 43.54	15:30	HSEA	1	V	45/180	SW, DI	45	OC	2	Facing south towards barge when dove-did not resight
24-Sep-11	08:38	16:45	47 45.98	122 43.45	16:09	HSEA	1	V	110/140	LO, SI, SW(N)	250	PC	2	About 10m from white stump; came within 40m at 16:11
24-Sep-11	08:38	16:45	47 45.98	122 43.45	16:16	HSEA	1	V	158/200	LO, SI	321	PC	2	
24-Sep-11	08:38	16:45	47 45.01	122 43.54	16:19	HSEA	1	V	50/152	LO, DI	100	S	1	Juvenile
26-Sep-11	08:24	12:06	47 45.01	122 43.43	08:25	HSEA	2	NA	50/80	LO, SI	275	L	1	1 adult and 1 sub-adult
26-Sep-11	08:24	12:06	47 45.14	122 43.57	08:30	HSEA	1	NA	50/10	LO, SI	200	R	1	At 08:35 on south side of Columbia barge, at 08:52 near tp13 ~100m from pile to be impacted
26-Sep-11	08:24	12:06	47 44.99	122 43.54	08:42	HSEA	1	NA	75/22	SW(N), SI, FO	110	L	1	Came within 5m of the boat at 08:49
26-Sep-11	08:24	12:06	47 45.05	122 43.43	08:56	HSEA	1	NA	200/270	LO, SI	5	R	1	At 08:56 begin 30 minute to clear zone, at 09:00 surfaced outside 50m zone ~75m heading northeast
26-Sep-11	08:24	12:06	47 44.70	122 44.32	09:05	CASL	11	I	50/265	RE	1900	L	2	6 CASL on packages, 5 on fence
26-Sep-11	08:24	12:06	47 44.70	122 44.32	09:05	HSEA	1	I	50/265	SW, LO	1900	L	2	
26-Sep-11	08:24	12:06	47 45.13	122 43.41	09:22	CASL	1	I	50/70	SW, DI	200	R	1	Heading north toward EHW1
26-Sep-11	08:24	12:06	47 45.03	122 43.42	09:59	HSEA	1	I	10/291	LO, DI	100	R	1	Construction crew work boat came within 1 ft before it dove
26-Sep-11	08:24	12:06	47 45.01	122 43.44	10:00	HSEA	1	I	50/235	SW	100	R	1	
26-Sep-11	08:24	12:06	47 45.09	122 43.51	10:15	HSEA	1	V	25/355	SW, DI	75	R	1	Facing northeast when dove, was a male seal-saw belly, very light face. At 10:23 ~75m from pile
26-Sep-11	08:24	12:06	47 45.03	122 43.42	10:15	HSEA	1	V	318/10	LO, RE, SI	500	R	1	Near tp1 EHW1
26-Sep-11	08:24	12:06	47 45.03	122 43.42	10:15	HSEA	1	V	115/348	SW(E)	225	R	1	
26-Sep-11	08:24	12:06	47 45.03	122 43.42	11:43	HSEA	1	V	25/285	LO, DI, SW(N)	130	L	1	
26-Sep-11	08:24	12:06	47 45.09	122 43.51	11:51	HSEA	1	V	100/210	LO, SI	50	R	1	Near barge, looking then sank

Date:	Time Observation Initiated: (hh:mm)	Time Observation Completed: (hh:mm)	Latitude	Longitude	Sighting Time (hh:mm)	Species	# of Anim(s)	Const. Type	Est. Dist. (m)/ Dir. to Ani(s)*	Behavior Type	Est. Dist. to Pile (m)**	Weather Conditions	Beaufort	Notes
26-Sep-11	08:24	12:06	47 44.97	122 43.38	12:02	HSEA	1	NA	10/210	LO, SI	240	L	1	
29-Sep-11	08:39	17:40	47 44.66	122 44.36	09:00	CASL	25	NA	80/060	RE	1800	S	0	14 on packages, 11 on fence, 15:09 during SS and blows. CASL were not barking, 11 on fence and 8 on packages (could not see whole fence where they normally haul out, after impact (15:20 CASL vocal again and counted 25 on fence as we passed by
29-Sep-11	08:39	17:40	47 44.96	122 43.53	09:06	HSEA	1	NA	80/210	LO, SI, SW(SE)	80	S	1	
29-Sep-11	08:39	17:40	47 45.03	122 44.26	09:11	HSEA	1	NA	150/192	TR, DI	1000	S	0	Travelling 192 degrees (south southwest)
29-Sep-11	08:39	17:40	47 45.08	122 43.50	09:30	HSEA	1	NA	125/350	SW, DI	225	S	1	Appears to be heading south towards barge
29-Sep-11	08:39	17:40	47 44.96	122 43.56	09:35	HSEA	2	NA	50/230	SW, LO, SI	200	S	1	One animal is likely to be Dana's sighting on Shocker
29-Sep-11	08:39	17:40	47 45.04	122 43.48	09:45	HSEA	1	NA	75/180	LO, SI	25	S	1	Begin 30min clearance at 09:45-seal in 50m zone-direction of travel unknown
29-Sep-11	08:39	17:40	47 44.97	122 43.42	10:03	HSEA	1	I	196/33	LO, SI, SW(N)	150	S	1	Could be the same individual that was spotted within 50m zone at 09:45
29-Sep-11	08:39	17:40	47 45.45	122 43.45	10:13	HSEA	2	I	450/5	SW, DI	500	S	1	Under EHW pier and just outside of it
29-Sep-11	08:39	17:40	47 44.94	122 43.59	10:52	HSEA	1	I	90/90	LO, DI, SW(S), FO	113	S	1	Had fish in mouth while swimming toward marginal pier
29-Sep-11	08:39	17:40	47 45.08	122 43.51	10:56	HSEA	1	NA	50/220	RE, DI	110	S	1	Resting at surface-belly up, dove-direction of travel unknown
29-Sep-11	08:39	17:40	47 44.94	122 43.59	11:01	HSEA	2	NA	75/87	LO, SI, SW (N then S)	111	S	1	
29-Sep-11	08:39	17:40	47 44.96	122 43.55	11:16	HSEA	2	SSV	50/158	LO, SI	111	S	1	1 of the 2 could be from previous sighting but different construction type; last sited at 11:14
29-Sep-11	08:39	17:40	47 45.08	122 43.51	11:25	HSEA	1	V	250/90	SW, DI	250	S	1	Likely animal previously sighted by Dana (#4 today) moving north along shoreline. At 10:37 turned south-vibe off
29-Sep-11	08:39	17:40	47 44.94	122 43.52	11:28	HSEA	2	V	30/60	LO, SI	121	S	1	1 of the 2 could be from previous sighting but different construction type
29-Sep-11	08:39	17:40	47 42.54	122 46.44	11:38	HSEA	1	V	90/285	TR, DI	5000	S	1	Seal TR (south)~170 degrees
29-Sep-11	08:39	17:40	47 44.94	122 43.52	11:53	HSEA	2	V	100/133	LO, SI	140	S	1	1 of the 2 could be from previous sighting but different construction type
29-Sep-11	08:39	17:40	47 42.47	122 46.58	11:55	HSEA	2	V	40/305	TR, SI	5000	S	1	2 HSEA heading north ~30m apart, 1 might be from sighting #89
29-Sep-11	08:39	17:40	47 44.97	122 43.54	12:29	HSEA	1	V	80/150	LO, SI, FO	200	S	1	Foraging with 3 glaucous winged gulls
29-Sep-11	08:39	17:40	47 45.01	122 43.45	12:36	HSEA	1	V	100/225	SW	170	S	1	
29-Sep-11	08:39	17:40	47 44.01	122 43.45	12:39	HSEA	1	V	75/105	LO, RE, SI, DI	180	S	1	Juvenile. Also sighted at 12:41, 12:51 LO, DI, RE

Date:	Time Observation Initiated: (hh:mm)	Time Observation Completed: (hh:mm)	Latitude	Longitude	Sighting Time (hh:mm)	Species	# of Anim(s)	Const. Type	Est. Dist. (m)/ Dir. to Ani(s)*	Behavior Type	Est. Dist. to Pile (m)**	Weather Conditions	Beaufort	Notes
29-Sep-11	08:39	17:40	47 44.97	122 43.54	12:39	HSEA	1	V	1/195	LO, SI	132	S	1	Within 3ft from port-stern of boat
29-Sep-11	08:39	17:40	47 44.01	122 43.45	13:00	HSEA	6	NA	50/95	LO, RE, SI, SW(N), FO, CH, SL*, MI	175	S	1	No activity; used tp9 for dist to pile; 4 of Stefanie's 6 have joined up with the 2 at 13:07; *splashing in water, lost sighting of 4 at 13:20; 2-3 individuals still in area; 2 hanging around white stump within 5 m n & s of it; fish splashing around white stump; 4 individuals were sited continuously until 15:00; 3 individuals were later sited within 50m of pile at 14:26; vibratory ended at 15:18
29-Sep-11	08:39	17:40	47 44.89	122 43.58	13:05	HSEA	6	NA	50/20	SW, DI	300-500	S	1	All were swimming north, except the one under marginal pier (DI). These were sighted at 50m/60 (3 individuals), 100m/225 (1 individual), 50m/40 (2 individuals). These same animals were seen at 13:53, then 14:24, 14:26, and 14:44 all within 50 meters of pile about to be driven.
29-Sep-11	08:39	17:40	47 45.52	122 43.90	13:06	HSEA	1	NA	100/190	SW, LO, CH, DI	1000	PC	2	Animal chuffed at surface Waypoint 024
29-Sep-11	08:39	17:40	47 45.08	122 43.51	13:17	HSEA	1	NA	250/320	SW, DI	350	PC	1	Appeared to be heading south
29-Sep-11	08:39	17:40	47 45.08	122 43.51	14:00	CASL	1	NA	250/330	PO	350	PC	1	Heading south
29-Sep-11	08:39	17:40	47 44.61	122 45.75	14:16	HSEA	2	NA	250/40	SW, LO, SI	2500	PC	1	Near shore west side of canal
29-Sep-11	08:39	17:40	47 45.18	122 44.15	14:16	HSEA	1	NA	100/345	LO, SI	860	S	1	
29-Sep-11	08:39	17:40	47 45.00	122 44.25	14:42	HSEA	1	I	65/055	TR, LO, DI	800	PC	1	Travelling east ~96 degrees
29-Sep-11	08:39	17:40	47 45.81	122 43.45	15:09	HSEA	1	SSI	see notes	SW, DI	120	S	1	Swimming northeast, looked back toward pile being driven and dove. Juvenile.
29-Sep-11	08:39	17:40	47 44.94	122 43.53	15:14	HSEA	1	I	25/249	LO, SI	146	S	1	In between vibratory with bubbles and vibratory without; this individual was potentially one of the 3 individuals that was sited on the south side of barge
29-Sep-11	08:39	17:40	47 45.08	122 43.52	15:40	HSEA	1	I	80/70	RE, SI	150	PC	1	No direction of travel detected, at 15:47 in same area feeding
29-Sep-11	08:39	17:40	47 45.01	122 43.45	16:19	HSEA	1	V	150/140	SW, DI	270	S	1	
29-Sep-11	08:39	17:40	47 44.95	122 43.49	16:20	HSEA	1	V	105/160	LO, SI, SW(S)	250	S	1	
29-Sep-11	08:39	17:40	47 48.10	122 42.83	16:34	HPOR	1	V	100/135	TR	5900	PC	2	Animal was traveling north Waypoint 025
29-Sep-11	08:39	17:40	47 42.29	122 45.88	16:42	HPOR	2	V	250/035	TR	5800	PC	2	Travelling 190 degrees (away from pile), may be 3 HPOR, cow and calf plus?
29-Sep-11	08:39	17:40	47 44.95	122 43.49	16:45	HSEA	2	V	115/165	LO, SI, SW(S)	270	S	1	First individual spotted immediately after vibe out could be same individual as previously sited and a second surfaced

Date:	Time Observation Initiated: (hh:mm)	Time Observation Completed: (hh:mm)	Latitude	Longitude	Sighting Time (hh:mm)	Species	# of Anim(s)	Const. Type	Est. Dist. (m)/ Dir. to Ani(s)*	Behavior Type	Est. Dist. to Pile (m)**	Weather Conditions	Beaufort	Notes
29-Sep-11	08:39	17:40	47 42.29	122 45.88	16:48	HSEA	1	V	350/170	RE, SI	6000	PC	2	Just after end of vibe= during 30min post-watch. Traveling 250 degrees at 16:50
29-Sep-11	08:39	17:40	47 45.08	122 43.51	16:50	HSEA	1	V	75/95	SW, SI	125	PC	1	Heading south
29-Sep-11	08:39	17:40	47 45.08	122 43.51	16:53	CASL	1	V	40/165	SW, LO, DI	85	PC	1	Heading south towards delta pier, last sighted ~100m south of barge heading south
29-Sep-11	08:39	17:40	47 42.13	122 45.73	16:59	HSEA	1	V	70/015	TR, DI	6000	PC	2	Travelling ~285 degrees
29-Sep-11	08:39	17:40	47 44.95	122 43.49	17:23	HSEA	2	V	25/38	LO, DI, SW(SE)	150	S	1	Tiny spotty pup was the sub adult
29-Sep-11	08:39	17:40	47 45.11	122 43.56	17:28	HSEA	1	V	400/68	LO, SI	500	OC	0	
30-Sep-11	08:20	15:50	47 45.09	122 43.60	08:30	HSEA	1	NA	300/230	DI	450	S	1	Swift sighted at 08:51
30-Sep-11	08:20	16:20	47 44.35	122 44.35	08:35	CASL	27	NA	60/60	RE	1800	PC	0	13 on fence, 14 on packages
30-Sep-11	08:20	15:50	47 44.96	122 43.47	08:35	HSEA	1	NA	<1/190	LO, RE, SI	93	PC	1	Individual resting on back. Similar to yesterday's sightings; stayed within 50m from our boat until 08:50; spotted again at 08:56 swimming on back then rolling to belling about 64m south of the boat near white anchor buoy; heading ne; sited again at 09:00 in front of boat on SE side; rotated on back and sank at 09:06
30-Sep-11	08:50	15:50	47 45.09	122 43.54	08:50	HSEA	1	NA	60/330	LO, DI	220	PC	1	Heading south, at 08:58 milling in area
30-Sep-11	08:20	16:20	47 45.06	122 44.21	08:58	HSEA	1	NA	70/316	SW, SI	1000	PC	0	TR 305° degrees
30-Sep-11	08:20	16:20	47 45.08	122 44.22	09:03	HSEA	1	NA	20/20	TR, LO, DI	1000	PC	0	Travelling 20 degrees
30-Sep-11	08:20	15:50	47 45.07	122 43.56	09:06	HSEA	1	NA	300/210	SI, SW	350	S	1	
30-Sep-11	08:20	16:20	47 45.10	122 44.22	09:11	HSEA	1	NA	185/95	SW, SI	700	PC	0	Inside WRA fence 1 meter
30-Sep-11	08:20	15:50	47 44.94	122 43.62	09:13	HSEA	1	NA	10/129	LO, SI	150	PC	1	Could be the same as previous sighting
30-Sep-11	08:20	15:50	47 45.65	122 43.80	09:17	HSEA	1	NA	100/85	SW, LO, DI	1000	PC	1	Waypoint 026 animal swimming north
30-Sep-11	08:50	15:50	47 44.98	122 43.40	09:35	HSEA	1	I	75/205	SW, DI	140	PC	1	Possibly moving west
30-Sep-11	08:20	15:50	47 45.09	122 43.54	09:41	HSEA	1	I	150/95	SW	250	S	1	Swimming south right toward pile they are about to impact
30-Sep-11	08:20	15:50	47 45.22	122 44.15	09:54	HSEA	1	SSI	150/253	TR, Di	902	S	1	Seals heading was 004°
30-Sep-11	08:50	15:50	47 45.08	122 43.51	10:21	HSEA	1	I	100/90	SW, DI	200	PC	1	Moving north parallel to shoreline
30-Sep-11	08:20	16:20	47 43.72	122 45.37	10:23	HSEA	2	I	40/140	TR, LO, SI	4000	PC	1	Swimming west across canal ~80m apart
30-Sep-11	08:20	15:50	47 47.80	122 42.59	10:24	HSEA	1	I	200/355	SW, DI	6000	PC	1	Waypoint 027 10:07 asked to move to 6km for acoustics
30-Sep-11	08:20	15:50	47 48.22	122 42.23	10:33	HSEA	1	V	75/110	SW, DI	6000	PC	1	Waypoint 028
30-Sep-11	08:20	16:20	47 42.58	122 46.22	10:33	HSEA	1	V	70/80	RE, SW	5500	PC	0	
30-Sep-11	08:20	16:20	47 42.31	122 46.15	10:35	HSEA	1	V	80/160	RE, SW, SI	6000	PC	1	
30-Sep-11	08:20	16:20	47 42.35	122 46.17	10:45	HSEA	1	V	45/310	SW, SI	6000	PC	1	Outside 50m zone



Date:	Time Observation Initiated: (hh:mm)	Time Observation Completed: (hh:mm)	Latitude	Longitude	Sighting Time (hh:mm)	Species	# of Anim(s)	Const. Type	Est. Dist. (m)/ Dir. to Ani(s)*	Behavior Type	Est. Dist. to Pile (m)**	Weather Conditions	Beaufort	Notes
30-Sep-11	08:20	15:50	47 44.96	122 43.45	10:53	HSEA	2	V	5/105*	LO, SI, SW(N)	115*	PC	1	*Recorded closest seal; the other was at 75m/200 and 175m from pile; seals were within 50m of each other at the same time heading north
30-Sep-11	08:20	15:50	47 45.96	122 43.70	10:55	HSEA	2	V	200/165	SW, DI	400	S	1	Swimming northeast toward and under marginal pier. Dove when boat came toward them. At 10:59 they were at 50m/230 swimming west toward fence
30-Sep-11	08:20	15:50	47 45.00	122 43.45	11:15	HSEA	1	V	200/27	SW	50	S	1	Swift saw animal at 11:28 swim out of area
30-Sep-11	08:20	16:20	47 42.50	122 46.38	11:16	HSEA	1	V	120/130	MI, SI	6000	OC	2	In tidal current
30-Sep-11	08:20	16:20	47 44.97	122 44.34	11:37	CASL	1	V	100/270	RE	900	PC	2	Bobbing and sinking, sleeping?
30-Sep-11	08:20	16:20	47 42.64	122 46.72	11:46	HPOR	5	V	30/100	MI	6000	PC	2	Possible forage diving
30-Sep-11	08:20	15:50	47 45.00	122 43.45	12:25	HSEA	7	NA	150/150	SW, DI, RE	300	OC	1	All animals were swimming in a group northward. Then they split up and spread out. Most of these animals (5 of them) were observed over the next hour, until 13:44. See below for sightings while driving
30-Sep-11	08:20	15:50	47 45.00	122 43.45	13:36	HSEA	1	SSI	125/50	DI, LO	300	OC	1	13:39, 13:43 swimming north then south toward marginal pier
30-Sep-11	08:20	15:50	47 45.00	122 43.45	13:41	HSEA	1	I	100/90	RE	275	OC	1	This is a juvenile that has been seen floating on its back several times. He was sighted just after impact with the bubble net on and right before impact with no bubble net.
30-Sep-11	08:20	15:50	47 45.00	122 43.45	13:43	HSEA	1	V	125/50	DI, LO	301	OC	1	
30-Sep-11	08:20	15:50	47 45.00	122 43.45	14:08	HSEA	1	I	100/200	LO, SW	275	PC	1	
1-Oct-11	08:14	17:04	47 45.12	122 43.59	08:24	CASL	1	NA	500/190	TR	500	OC	1	Travelling Swiftly heading south towards delta pier
1-Oct-11	08:14	17:04	47 44.88	122 44.24	08:36	CASL	23	NA	800/080	RE	1200	OC	1	6 on fence, 17 on package
1-Oct-11	08:14	17:04	47 44.96	122 43.55	08:46	HSEA	1	NA	115/195	LO, SI, SW(E)	305	OC	1	At 08:55 seal moved further southwest
1-Oct-11	08:14	17:04	47 45.01	122 43.45	09:00	HSEA	1	I	75/175	LO, SI, RE	315	OC	1	
1-Oct-11	08:14	17:04	47 45.23	122 44.19	09:00	HSEA	1	I	125/244	TR	859	OC	1	Heading 345°
1-Oct-11	08:14	17:04	47 45.69	122 43.90	09:01	CASL	1	I	50/185	TR, DI	1000	OC	1	Visible head and blows, dive, backup blow dive travel Waypoint 29
1-Oct-11	08:14	17:04	47 44.88	122 44.54	09:03	HSEA	1	I	75/10	SW, DI	130	OC	1	No direction of travel detected-southwest at 09:06 near 50m zone-sighted by shj heading southwest, at 09:09 in 50m zone ~25m from pile, at 09:11 next to pile, at 09:13 on south side outside 50m zone sighted by ds, at 09:14 last sight by ds, soft start began at 09:19
1-Oct-11	08:14	17:04	47 45.07	122 43.53	09:03	HSEA	1	I	50/340	SW, LO, SI	1250	OC	1	Travelling 210 degrees

Date:	Time Observation Initiated: (hh:mm)	Time Observation Completed: (hh:mm)	Latitude	Longitude	Sighting Time (hh:mm)	Species	# of Anim(s)	Const. Type	Est. Dist. (m)/ Dir. to Ani(s)*	Behavior Type	Est. Dist. to Pile (m)**	Weather Conditions	Beaufort	Notes
1-Oct-11	08:14	17:04	47 45.76	122 43.86	09:06	HSEA	1	I	50/225	SW, SI	1000	OC	1	Waypoint 30
1-Oct-11	08:14	17:04	47 44.97	122 43.64	09:27	HSEA	1	I	185/246	LO, SI, SW(E)	405	OC	1	Could be the same as previous sighting
1-Oct-11	08:14	17:04	47 44.95	122 43.47	09:50	HSEA	1	I	85/15	LO, SI, SW(E)	200	OC	1	
1-Oct-11	08:14	17:04	47 45.01	122 43.45	10:36	HSEA	1	NA	25/50	DI, SW	190	OC	1	Juvenile that has been seen frequently floating on his back.
1-Oct-11	08:14	17:04	47 44.75	122 44.57	10:43	HSEA	1	NA	500/313	TR, SI	2400	OC	1	Travelling south along west bank
1-Oct-11	08:14	17:04	47 45 058	122 43.50	10:49	HSEA	1	NA	100/40	SW, DI	200	OC	1	Direction of travel not clear, could be a resight of shj's last sighting
1-Oct-11	08:14	17:04	47 44.77	122 44.45	11:22	HSEA	1	I	120/050	TR, SI	1400	OC	1	Travelling south along fence
1-Oct-11	08:14	17:04	47 45.63	122 43.85	11:32	HSEA	1	I	250/87	SW, DI	800	OC	0	Waypoint 31
1-Oct-11	08:14	17:04	47 45.00	122 43.45	11:38	HSEA	1	I	310/48	RE	140	OC	1	
1-Oct-11	08:14	17:04	47 45.00	122 43.45	11:44	HSEA	1	I	70/120	SW	210	OC	1	
1-Oct-11	08:14	17:04	47 45.04	122 43.41	11:46	HSEA	1	I	40/30	SW, DI	220	OC	1	Heading south parallel to shore, at 11:57 appeared to be feeding then surfaced and rolled onto back, was a juvenile, previously sighted by shl #129
1-Oct-11	08:14	17:04	47 45.04	122 43.40	11:52	HSEA	1	I	90/250	SW, DI	90	OC	1	Appeared to be heading northwest
1-Oct-11	08:14	17:04	47 45.01	122 43.45	12:21	HSEA	1	NA	500/230	SW, SI	500	OC	1	
1-Oct-11	08:14	17:04	47 45.18	122 44.20	12:25	HSEA	1	NA	400/290	TR, SI	1500	OC	1	Travelling 180 degrees
1-Oct-11	08:14	17:04	47 44.99	122 43.55	12:36	HSEA	1	NA	75/312	LO, SI	<1	OC	1	Surfaced next to pile <1m; spotted at 12:40 about 100m from pile heading N toward barge ("Columbia")
1-Oct-11	08:14	17:04	47 45.98	122 43.36	12:38	HPOR	2	NA	200/182	MI	1700	OC	0	Waypoint 32
1-Oct-11	08:14	17:04	47 44.70	122 44.?	12:40	HSEA	1	NA	50/198	TR, LO, SI	2000	PC	0	Seconds not recorded, travelling 197 degrees directly in front of boat while moving to start position
1-Oct-11	08:14	17:04	47 44.99	122 43.55	12:45	HSEA	1	NA	180/15	LO, SI, SW(N)	210	OC	1	
1-Oct-11	08:14	17:04	47 46.01	122 43.31	12:48	HSEA	7	NA	500/57	RE	2200	OC	1	Animals are hauled out on a floating dock Waypoint 33
1-Oct-11	08:14	17:04	47 44.66	122 44.71	12:50	HSEA	2	NA	450/104	SW, SI	1800	PC	0	Swimming towards each other
1-Oct-11	08:14	17:04	47 45.06	122 43.45	13:23	HSEA	1	NA	180/220	SW, DI	100	OC	1	Heading south away from south side of barge
1-Oct-11	08:14	17:04	47 44.97	122 43.65	13:46	HSEA	1	I	115/175	LO, SI, SW(W)	189	OC	1	
1-Oct-11	08:14	17:04	47 45.01	122 43.48	13:58	HSEA	1	I	50/155	LO, SI, SW(S)	100	OC	1	Spotted again by Streak (sighting 122) during different construction type
1-Oct-11	08:14	17:04	47 45.01	122 43.45	14:09	HSEA	1	SSI	50/25	LO, SI	130	OC	1	Shocker's sighting right before Soft start (163b). Monitoring coordinator sighted after Soft start at 14:19
1-Oct-11	08:14	17:04	47 44.97	122 43.50	14:10	HSEA	1	SSI	50/340	LO, SI, SW(N)	120	OC	1	Swam towards pile

Date:	Time Observation Initiated: (hh:mm)	Time Observation Completed: (hh:mm)	Latitude	Longitude	Sighting Time (hh:mm)	Species	# of Anim(s)	Const. Type	Est. Dist. (m)/ Dir. to Ani(s)*	Behavior Type	Est. Dist. to Pile (m)**	Weather Conditions	Beaufort	Notes
1-Oct-11	08:14	17:04	47 44.97	122 43.46	14:13	HSEA	1	I	80/271	LO, SI	175	OC	1	Sited again at 14:20; swam away from pile
1-Oct-11	08:14	17:04	47 45.09	122 43.60	14:16	HSEA	1	I	30/90	SW, DI	100	OC	1	Heading north towards EHW1, north side of barge
1-Oct-11	08:14	17:04	47 45.04	122 43.41	15:47	HSEA	1	NA	50/350	LO, SI	200	L	1	Sank facing northeast, at 16:05 milling in same area, at 16:16 off southwest corner of Columbia, milling and looking, at 16:27 sighted by shj outside 50m zone ~100m east of pile
1-Oct-11	08:14	17:04	47 43.74	122 43.74	16:26	HPOR	2	I	150/86	TR	1300	F, L	1	Waypoint 34
1-Oct-11	08:14	17:04	47 45.00	122 43.45	16:32	HSEA	1	I	100/225	LO, SI	300	L	1	
1-Oct-11	08:14	17:04	47 45.00	122 43.60	16:43	HSEA	1	I	25/300	LO, SI	100	OC	1	
1-Oct-11	08:14	17:04	47 45.06	122 43.53	16:47	HSEA	1	I	100/25	LO, SI	100	L	1	3 meters from north end of barge
1-Oct-11	08:14	17:04	47 45.48	122 45.26	16:53	HPOR	4	I	100/047	TR	2160	OC	1	Heading 358° spotted on the 30 min post obs travelling slowly as a pod
1-Oct-11	08:14	17:04	47 44.91	122 43.44	17:02	HSEA	1	I	5/280	LO, SI	250	L	1	Last sighting of the day
3-Oct-11	08:39	18:35	47 44.96	122 43.46	08:28	HSEA	2	NA	100/190	LO, SI, SW(S)	210	L	1	Not sure what pile we are working on so I used tp9 for distance to pile
3-Oct-11	08:39	18:35	47 44.96	122 43.46	08:37	HSEA	1	NA	10/290	LO, DI	210	L	1	Confirmed working on tp6 next
3-Oct-11	08:39	18:35			08:42	HSEA	1	NA	100/270	RE	100	L	1	
3-Oct-11	08:39	18:35	47 44.70	122 44.32	09:04	CASL	14	NA	75/75	RE, SW	1800	PC	2	3 on fence, 11 on package
3-Oct-11	08:39	18:35	47 45.11	122 43.50	09:05	HSEA	1	NA	250/105	SI, TR	230	L	1	Possibly the same individual as Shocker number sighting 170 last sited at 09:46
3-Oct-11	08:39	18:35	47 44.96	122 43.46	09:08	HSEA	2	NA	80/50	LO, SI, DI, SW(S)	225	L	1	Last sighted 09:18 within marginal pier
3-Oct-11	08:39	18:35	47 44.96	122 43.46	09:20	HSEA	1	NA	76/282	LO, SI	115	L	1	Potentially Swift's daily sighting number 2
3-Oct-11	08:39	18:35	47 44.96	122 43.46	09:28	HSEA	1	NA	138/310	LO, SI	100	L	1	About 10m from TP 9 and the barge
3-Oct-11	08:39	18:35	47 45.08	122 43.51	11:27	HSEA	1	NA	167/11	LO	50	OC	1	
3-Oct-11	08:39	18:35			11:40	HSEA	1	I	100/350	SW(E)	200	OC	1	
3-Oct-11	08:39	18:35	47 45.04	122 43.62	11:56	HSEA	1	I	50/90	LO, SI	110	OC	2	Sited within 1m of TP9 (kissing the pile) amongst the batter piles moving away from TP6 (south). Bubble curtain on at 12:00, seal continued to move south at same rate
3-Oct-11	08:39	18:35	47 45.01	122 43.50	12:04	HSEA	1	SSI	50/280	LO, DI, SW(S)	120	OC	2	Same individual as previous sighting; dove when hammer was turned on; heading south last sited at 12:04
3-Oct-11	08:39	18:35	47 45.02	122 43.47	12:09	HSEA	1	SSI	96/190	LO, SI	213	OC	2	Same individual as previous sighting; headed southeast towards marginal
3-Oct-11	08:39	18:35	47 45.04	122 43.40	13:54	HSEA	1	V	60/225	LO, SI	180	OC	2	
3-Oct-11	08:39	18:35	47 46.17	122 43.07	14:51	HSEA	6	NA	250/50	RE	3000	OC	4	Waypoint 35 animals hauled out on a dock by magnetic pier
3-Oct-11	08:39	18:35	47 45.04	122 43.40	15:05	HSEA	1	NA	60/142	LO, SI	160	OC	2	
3-Oct-11	08:39	18:35	47 45.01	122 43.45	15:20	HSEA	1	NA	80/232	LO, SI	201	OC	2	Sighting from Streak; used tp4 for pile distance

Date:	Time Observation Initiated: (hh:mm)	Time Observation Completed: (hh:mm)	Latitude	Longitude	Sighting Time (hh:mm)	Species	# of Anim(s)	Const. Type	Est. Dist. (m)/ Dir. to Ani(s)*	Behavior Type	Est. Dist. to Pile (m)**	Weather Conditions	Beaufort	Notes
3-Oct-11	08:39	18:35	47 45.01	122 43.45	15:34	HSEA	1	NA	110/304	LO, SI	100	OC	2	Sighting from Streak; could be the same individual as previous ; used tp4 for distance to pile
3-Oct-11	08:39	18:35	47 45.03	122 43.43	16:07	HSEA	1	NA	25/48	LO, SI	205	OC	2	Back on Shocker; seal had a white face
3-Oct-11	08:39	18:35	47 45.02	122 43.43	16:32	HSEA	1	I	15/110	LO, RE, SI	210	OC	2	Seal had a white face could be the same as previous sighting
3-Oct-11	08:39	18:35	47 45.10	122 43.62	16:41	HSEA	1	I	85/271	SW(S)	225	OC	2	Was not observed above surface during impact activities
3-Oct-11	08:39	18:35	47 45.18	122 43.44	17:00	HSEA	1	I	65/30	RE	175	OC	1	
3-Oct-11	08:39	18:35	47 46.31	122 43.30	17:10	HPOR	1	I	75/240	TR	3000	OC	3	Waypoint 36 (12:25 moving out to 4km away from 950m at tie off can on the north side of EHW1, b4)
3-Oct-11	08:39	18:35	47 45.05	122 43.43	17:26	HSEA	1	V	200/215	LO, SI, SW(S)	260	OC	2	
3-Oct-11	08:39	18:35	47 45.15	122 43.45	17:27	HSEA	1	V	75/215	SW	80	OC	1	
3-Oct-11	08:39	18:35	47 45.17	122 43.45	17:33	HSEA	1	V	125/215	SI	10	OC	1	
3-Oct-11	08:39	18:35	47 45.16	122 43.45	18:00	HSEA	1	V	80/110	DI	200	OC	1	Swimming north just off bow of barge
3-Oct-11	08:39	18:35	47 46.65	122 43.32	18:05	HPOR	2	V	100/240	TR	2800	OC, L	2	Waypoint 37 (14:34 moving back in close to next pile for impact)
3-Oct-11	08:39	18:35	47 45.17	122 43.51	18:15	CASL	1	V	50/140	PO	75	OC	1	Porpoising and jumping headed southwest around west side of work barge
3-Oct-11	08:39	18:35	47 45.51	122 45.15	18:20	HPOR	3	V	75/312	PO	2310	L	2	Sighted during our 30min post-observation, porpoising in multiple directions
4-Oct-11	08:05	16:40	47 45.18	122 43.48	09:51	HSEA	1	NA	100/255	SW, DI	200	OC, 1	1	Waypoint 005
4-Oct-11	08:05	16:40	47 45.06	122 43.40	09:56	CASL	1	NA	100/325	TR	200	PC	1	
4-Oct-11	08:05	16:40	47 45.19	122 43.49	10:00	CASL	1	NA	60/260	TR, DI	130	OC	2	
4-Oct-11	08:05	16:40	47 45.16	122 43.55	11:01	CASL	1	V	80/190	TR, LO, DI	90	OC	2	Extraction-surfaced going south moving quickly making several shallow dives then seen 150m further south repeating shallow dives
4-Oct-11	07:50	16:42	47 44.00	122 44.88	11:25	CASL	14	V	200/120	RE	1800	PC	3	Coming back into service dock to get fuel; spotted 2 on package and 12 along fence. Could be/are the same individuals as previous; same individual. As sighting 3 but only spotted 14 (7 more) when pass the fence
4-Oct-11	07:50	16:42	47 44.00	122 44.88	12:34	HPOR	2	NA	100/315	SW (NW)	1150	L	2-3	Wrote in rite-in-rain notebook due to light rain; well outside of range; no activity; sited again at 12:43 near magnetic pier continued course northwest
4-Oct-11	07:50	16:42	47 44.55	122 44.43	14:00	CASL	22	NA	100/80	RE	1800	PC	3	Coming back into dock to pick up passenger; spotted 12 on package and 10 along fence. Could be/are the same individuals as previous two sightings but noticed more on the "package"

Date:	Time Observation Initiated: (hh:mm)	Time Observation Completed: (hh:mm)	Latitude	Longitude	Sighting Time (hh:mm)	Species	# of Anim(s)	Const. Type	Est. Dist. (m)/ Dir. to Ani(s)*	Behavior Type	Est. Dist. to Pile (m)**	Weather Conditions	Beaufort	Notes
4-Oct-11	08:05	16:40	47 44.95	122 43.57	14:30	HSEA	1	I	40/335	TR, LO, DI	110	PC	2	
4-Oct-11	08:05	16:40	47 45.95	122 43.39	14:36	HSEA	1	I	125/359	LO, SI	142	PC	1	
4-Oct-11	08:05	16:40	47 45.07	122 43.32	15:30	HSEA	1	V	25/320	LO, SI	200	C	1	
4-Oct-11	08:05	16:40	47 45.15	122 43.15	15:46	HSEA	1	V	40/190	TR, SI	190	PC	2	Heading south
4-Oct-11	08:05	16:40	47 45.18	122 43.32	16:19	HSEA	1	V	250/350	LO, SI	300	C	1	Sighted during 30min post-observations
5-Oct-11	07:20	17:23	47 45.12	122 43.34	09:20	HSEA	3	NA	60/180	TR, SI	NA	OC	1	2 traveling together at 175 degrees-joined another HSEA near white stump
5-Oct-11	07:20	17:23	47 45.14	122 43.32	09:36	HSEA	1	NA	40/150	TR, LO	NA	OC	1	Travelling 170 degrees
5-Oct-11	07:20	17:23	47 44.75	122 44.96	11:23	CASL	21	NA	620/089	RE	2000	OC	1	Hauled out on security fence buoy's
5-Oct-11	07:20	17:23	47 45.35	122 43.44	11:40	HSEA	1	NA	10/130	RE, SI	230	OC	1	Sleeping, possibly resighted as #8
5-Oct-11	07:20	17:23	47 45.34	122 43.47	11:53	HSEA	1	NA	40/165	SW, SI	110	OC	1	Bumped orange barrier under guard shack - inside EHW1 at 11:56, 100m from pile at 12:56, same seal? 13:47 in EHW, staying in area, ~100m from pile,
5-Oct-11	07:20	17:23	47 44.73	122 44.97	11:53	HSEA	1	NA	575/259	RE	2030	OC	0	
5-Oct-11	11:30	17:23	47 45.12	122 43.45	12:34	HSEA	1	NA	30/17	LO, DI	175	OC	1	
5-Oct-11	07:20	17:23	47 45.17	122 43.49	12:58	HSEA	1	NA	30/45	SW, DI	70	L	1	Could be animal previously sighted by BM, heading east?
5-Oct-11	07:20	17:23	47 45.38	122 43.47	13:22	CASL	1	NA	25/90	SL, TR	200	L	1	Heading south southwest
5-Oct-11	07:20	17:23	47 45.34	122 43.47	13:55	HSEA	1	NA	40/165	SW, SI	20	R	1	13:55 in Exclusion Zone so added sighting # 8 b. No active construction
5-Oct-11	11:30	17:23	47 45.12	122 43.45	14:46	HSEA	1	NA	210/322	SW, DI	10	OC	0	14:48 animal out of 50m zone animal is a small juvenile. No active construction
5-Oct-11	07:20	17:23	47 45.16	122 43.44	15:07	HSEA	1	NA	20/210	LO, SI	30	OC	1	Under EHW piles almost directly in (east) from pile
5-Oct-11	07:20	17:23	47 45.29	122 43.52	15:10	HSEA	1	NA	75/135	SW, DI	30	L	1	In Exclusion Zone heading east, dove under EHW1
5-Oct-11	07:20	17:23	47 40.27	122 46.57	15:24	CASL	1	NA	100/018	DI	10000	L	1	
5-Oct-11	07:20	17:23	47 40.27	122 46.57	15:31	HSEA	1	NA	225/078	SW	10000	L	1	
5-Oct-11	11:30	17:23	47 45.12	122 43.45	15:50	HSEA	1	NA	125/340	SW, DI	100	OC	0	
5-Oct-11	07:20	17:23	47 45.16	122 43.44	16:07	HSEA	1	V	25/60	SW, SI	30	OC	1	Directly 45 degrees under west EHW1 piles from pile to be driven, hammer on pile
5-Oct-11	11:30	17:23	47 45.12	122 43.45	16:10	HSEA	1	V	50/340	SW, DI	150	OC	0	
5-Oct-11	07:20	17:23	47 40.27	122 46.57	16:32	HPOR	1	V	75/360	DI	10000	L	1	

Date:	Time Observation Initiated: (hh:mm)	Time Observation Completed: (hh:mm)	Latitude	Longitude	Sighting Time (hh:mm)	Species	# of Anim(s)	Const. Type	Est. Dist. (m)/ Dir. to Ani(s)*	Behavior Type	Est. Dist. to Pile (m)**	Weather Conditions	Beaufort	Notes
5-Oct-11	07:20	17:23	47 45.16	122 43.44	16:44	HSEA	1	V	25/210	SW, TR, SI, DI	30	R	1	16:45 seen in Exclusion Zone moving steadily 310 degrees along surface parallel to last (westerly) row of EHW1 piles, DI, 16:47 resurface, -out Exclusion Zone at 16:49, seen again several times by Swift MMO out of Exclusion Zone, seen again 17:03 after final drive ends ~110m from pile near guard shack on EHW NW end (SW, DI) towards piles, HSEA regularly spotted here all day
5-Oct-11	07:20	17:23	47 45.28	122 43.50	16:51	HSEA	1	V	90/65	MI, DI	80	R	1	Same seal that was in 50m zone (BM sighting #11)
5-Oct-11	07:20	17:23	47 45.28	122 43.50	16:54	HSEA	1	V	40/50	MI, DI	120	R	1	At entrance of EHW1 milling (BM sighting #11), at 17:05 at northwest corner of EHW1 SW/DI
5-Oct-11	07:20	17:23	47 45.16	122 43.44	17:07	HSEA	1	V	100/235	TR, DI	65	R	1	Traveled 140 degrees along surface for ~8m then dove moving towards barge ~65m from pile just driven
5-Oct-11	07:20	17:23	47 45.29	122 43.53	17:15	CASL	1	V	30/250	TR	250	R	1	Heading north
8-Oct-11	08:05	17:00	47 45.22	122 43.44	09:08	HSEA	1	V	18/250	FO, SW, SI	88	OC	1	Seal moving under boom at ~60-80m and ~325ft from pile. 09:11 I gave go ahead after close approach to 50m zone
8-Oct-11	08:05	17:00	47 45.22	122 43.44	09:18	HSEA	1	V	25/260	SW, DI	88	OC	1	Small juvenile came up near where #1 sighted, 09:20 and 09:21 SW and DI, in Exclusion Zone 09:22 next to d6 (derrick 6), 09:23 in again, end vibe 09:27, probable same HSEA came up 70m from pile, 09:34 swimming directly towards pile, 09:38 out Exclusion Zone, up again 09:39 (out Exclusion Zone)
8-Oct-11	08:05	17:00	47 45.55	122 44.05	13:20	STSL	1	NA	200/80	RE	1450	S	2	Hauled out at delta pier, south side, on vessel
8-Oct-11	08:05	17:00	47 45.55	122 44.05	13:20	CASL	29	NA	200/80	RE	1450	S	2	Hauled out at delta pier on vessels
8-Oct-11	08:05	17:00	47 45.55	122 44.05	13:20	CASL	14	NA	100/210	RE	1600	S	2	Hauled out on WRA fence, south side of delta pier
8-Oct-11	08:05	17:00	47 45.25	122 43.54	14:05	CASL	1	NA	150/180	PO	200	PC	3	Travelling rapidly, porpoising, heading south
8-Oct-11	08:05	17:00	47 45.25	122 43.53	14:23	HSEA	1	NA	80/30	RE, SI	120	PC	3	At entrance of EHW1, resting, no direction of travel, at 14:40 same area
8-Oct-11	08:05	17:00	47 45.19	122 43.47	15:45	HSEA	1	I	49/42	SW (E), DI	90	PC	3	Heading east
8-Oct-11	08:05	17:00	47 45.18	122 43.44	15:55	HSEA	1	V	25/292	SW, DI	40	PC	1	Small seal came up between soft starts #1 & 2 under large block in west side EHW, swam ~2m on surface towards pile and dove, (see paula #12 notes), RE-spotted by Swift.
8-Oct-11	08:05	17:00	47 45.19	122 43.46	16:05	HSEA	1	V	50/82	RE, SI	130	PC	3	No direction of travel obvious but turned and sank heading east, likely same seal as sighting #12 and BM sighting #3



Date:	Time Observation Initiated: (hh:mm)	Time Observation Completed: (hh:mm)	Latitude	Longitude	Sighting Time (hh:mm)	Species	# of Anim(s)	Const. Type	Est. Dist. (m)/ Dir. to Ani(s)*	Behavior Type	Est. Dist. to Pile (m)**	Weather Conditions	Beaufort	Notes
8-Oct-11	08:05	17:00	47 45.18	122 43.44	16:31	HSEA	1	V	18/230	SW, SI	NA*	PC	1	* surfaced under south large cement block ~21 minutes into post watch, 40m from pile tp1 (not gone, hammer still on) extraction, may be same seal as sight #3. Up again close to old pile area (tp1) at 16:35, up 16:38 further north near end of EHW1. Resting 16:40, up again while Construction crew jiggling pile repeatedly, pile is still on hammer ~60 to 80m from where seal is surfacing, 16:45 up again
17-Oct-11	08:15	17:09	47 45.07	122 43.43	10:20	HSEA	1	NA	70/210	SW(N), DI	NA	S	1	Heading north, adult animal, next pile to drive unknown
17-Oct-11	08:15	17:09	47 45.07	122 43.43	10:33	HSEA	1	NA	90/240	SW(SW), DI	NA	S	1	Heading southwest, dove under piles
17-Oct-11	08:15	17:09	47 45.12	122 43.37	12:14	HSEA	1	NA	20/172	SW(SW), DI, CD, FO	135	S	1	Heading southeast, may be foraging, changed direction then foraging, on back
17-Oct-11	08:25	17:07	47 44.58	122 44.00	12:41			V	30/SE		2000			
17-Oct-11	08:25	17:07	47 44.58	122 44.00	12:44	STSL	1	V	35/SE	LO, TR(W)	2000	S	0-1	Popped up outside boom, looked like he was travelling w
17-Oct-11	08:25	17:07	47 44.58	122 44.00	12:48	STSL	1	V	30/SE	HO, RE	2000	S	0-1	12:48 laid down, same individual moving back and froth
17-Oct-11	08:25	17:07	47 44.58	122 44.00	12:58	CASL	3	SSV	30/SE	PL, FI	2000	S	0-1	PI = playing, FI = fighting. Remained in water the entire vibe time and after
17-Oct-11	08:15	17:00	47 44.63	122 43.90	14:17	STSL	1	NA	30/N	SW	1200	S	1	SW/HO
17-Oct-11	08:20	17:09	47 45.25	122 43.43	15:13	HSEA	1	V	10/30	SW(N), SI	200	C	0	Hammer recently off.
17-Oct-11	08:25	17:07	47 44.58	122 44.00	15:16	CASL	2	SSV	30/SE	SW, UN	2000	S	0-1	Soft start. Un = fighting
17-Oct-11	08:25	17:07	47 44.58	122 44.00	15:19	CASL	2	SSV	70/SE	TR(E)	2000	S	0-1	
17-Oct-11	08:15	17:09	47 45.07	122 43.42	16:18	HSEA	1	V	25/90	LO, SI	125	PC	2	
18-Oct-11	08:08	15:50	47 45.13	122 43.41	08:08	HSEA	1	NA	100/95	SW(S), DI	150	S	2	Moving south along beach
18-Oct-11	08:14	15:50	47 44.58	122 44.00	08:14	CASL	25	NA	8/SE	RE, SW, VO	2000	S	2	Baseline observation, 21 RE, 4 SW
18-Oct-11	08:15	16:00	47 44.63	122 43.90	08:15	STSL	1	NA	20/NW	RE	1200	S	2	RE on delta north of package east end. Wet.
18-Oct-11	08:15	16:00	47 44.63	122 43.90	08:15	CASL	19	NA	20/NW	RE, SW	120	S	2	4 on west end, RE. 15 on east end, 13 RE, 2 SW/VO
18-Oct-11	08:14	15:50	47 44.58	122 44.00	08:27	CASL	2	NA	60/NW	RE	2000	S	2	Swift called in 2 CASLs RE on dock attached to end of pier
18-Oct-11	08:08	15:50	47 45.14	122 43.38	09:08	HSEA	1	NA	40/263	LO, DI(S)	75	S	1	
18-Oct-11	08:08	15:50	47 45.14	122 43.39	09:19	HSEA	1	NA	40/260	SW(S), DI(S)	100	S	1	
18-Oct-11	08:08	15:50	47 45.13	122 43.38	09:27	HSEA	1	NA	100/307	MI(S), DI	125	S	1	Glare very bad toward the beach
18-Oct-11	08:08	15:50	47 45.06	122 43.52	09:30	HSEA	1	NA	50/342	SW(W), LO, DI	100	S	1	Moving west
18-Oct-11	08:08	15:50	47 45.07	122 43.50	10:08	HSEA	1	NA	105/50	SW, DI	100	S	1	No direction of travel detected

Date:	Time Observation Initiated: (hh:mm)	Time Observation Completed: (hh:mm)	Latitude	Longitude	Sighting Time (hh:mm)	Species	# of Anim(s)	Const. Type	Est. Dist. (m)/ Dir. to Ani(s)*	Behavior Type	Est. Dist. to Pile (m)**	Weather Conditions	Beaufort	Notes
18-Oct-11	08:14	15:50	47 44.58	122 44.00	10:11	CASL	2	NA	40/W	TR(E), SI	2000	S	2	2 CASLs popped up inside boom heading East toward package
18-Oct-11	08:08	15:50	47 45.13	122 43.38	10:16	HSEA	1	NA	75/187	SW(SE), SI	100	S	1	
18-Oct-11	08:15	16:00	47 44.63	122 43.90	10:38	HSEA	1	NA	150/NE	SW, DI	1050	S	2	SW around marginal wharf
18-Oct-11	08:08	15:50	47 45.04	122 43.50	10:51	HSEA	1	V	60/74	SW(NW), DI	140	S	1	Heading northwest
18-Oct-11	10:55	15:50	47 44.66	122 44.37	10:58	CASL	25	V	75/50	RE	1800	S	2	25 CASL on fence buoys
18-Oct-11	08:08	15:50	47 45.13	122 43.38	11:11	HSEA	1	V	50/240	LO, SI	50	S	1	11:02 STSL in water, 11:06 STSL out of water
18-Oct-11	08:14	15:50	47 44.58	122 44.00	11:12	CASL		V			2000	S		Divers jumped into water near end of pier on south end to clean, startled CASLs but none entered the water as a result, just lots of VO and sitting up.
18-Oct-11	08:08	15:50	47 45.13	122 43.38	11:13	HSEA	1	V	100/315	SW(N), DI	150	S	1	13:42 glare really bad to the south southeast
18-Oct-11	08:08	15:50	47 45.06	122 43.50	11:20	HSEA	1	V	25/312	LO, DI	110	S	2	No direction of travel detected
18-Oct-11	08:14	15:50	47 44.58	122 44.00	11:21	CASL	2	SSV	8/S	HO, EW	2000	S	0-1	2 CASLs playing/fighting and HO and entered water repeatedly off package
18-Oct-11	08:08	15:50	47 45.05	122 43.50	11:24	HSEA	1	SSV	139/330	LO, SI	100	S	2	No behavior observed, northwest of previous position
18-Oct-11	10:55	15:50	47 45.06	122 44.22	12:13	HSEA	1	NA	250/275	TR(190)	NA	S	2	
18-Oct-11	08:08	15:50	47 45.06	122 43.49	12:58	HSEA	1	NA	25/245	SW(E), DI	115	S	2	Heading east towards beach, larger pale animal
18-Oct-11	08:08	15:50	47 45.06	122 43.49	13:17	HSEA	1	V	200/136	SW(N), CD, DI	300	S	2	No behavior observed but seal too far for good visual
18-Oct-11	08:14	15:50	47 44.58	122 44.00	13:33	CASL	1	V	20/S	TR(N)	2000	S	1-2	Approached package from the south, about to HO but slid back into the water
18-Oct-11	08:14	15:50	47 44.58	122 44.00	13:42	CASL	2	V	60/NW	RE	2000	S	1-2	2 CASLs that Swift called in at 08:27 confirmed to be still RE on dock by Ugly Duck
18-Oct-11	08:14	15:50	47 44.58	122 44.00	13:51	CASL	1	V	20 to 8/S	TR(N), HO, RE	2000	S	1-2	Individual that slid off package at 13:33 came back from south, HO and is now sitting up
18-Oct-11	11:45	15:50	47 45.07	122 43.42	14:08	HSEA	1	V	50/55	SW(N), DI	106	S	0	Swimming north and dove
18-Oct-11	08:14	15:50	47 44.58	122 44.00	14:28	CASL	25	V	8/S	VO, RE, UN	2000	S	2-3	21 RE, 4 SW, animals are very aggressive and combative, UN = biting.
18-Oct-11	10:55	15:50	47 45.06	122 44.22	14:45	HSEA	1	V	12/349	SW(80), DI(80)	NA	S	3	
18-Oct-11	11:45	15:50	47 45.07	122 43.42	15:36	HSEA	1	V	120/240	SW(S), SI	180	S	1	Swimming south and sank
19-Oct-11	07:50	16:41	47 44.63	122 43.90	07:50	CASL	24	NA	20/N	RE, SW	900	S	0	3 RE (west). 20 RE, 2SW (east)
19-Oct-11	07:50	16:41	47 44.63	122 43.90	07:50	STSL	1	NA	20/N	RE	900	S	0	Re (east)
19-Oct-11	07:48	16:41	47 45.09	122 43.49	07:51	HSEA	1	NA	60/86	SW(S), DI	150	S	1	Heading south
19-Oct-11	07:48	16:41	47 44.98	122 43.53	07:53	HSEA	1	NA	50/130	SW(S), DI	175	PC	0	
19-Oct-11	07:48	16:41	47 44.59	122 44.45	08:00	CASL	18	NA	150/40	RE	1800	PC	1	18 CASL on fence

Date:	Time Observation Initiated: (hh:mm)	Time Observation Completed: (hh:mm)	Latitude	Longitude	Sighting Time (hh:mm)	Species	# of Anim(s)	Const. Type	Est. Dist. (m)/ Dir. to Ani(s)*	Behavior Type	Est. Dist. to Pile (m)**	Weather Conditions	Beaufort	Notes
19-Oct-11	07:48	16:41	47 45.08	122 43.48	08:02	HSEA	1	V	50/110	SW(S), DI	170	S	1	Heading south
19-Oct-11	07:48	16:41	47 45.00	122 45.00	08:07	HSEA	1	V	30/280	SW	70	S	1	Juvenile SW toward piling. At 8:21 LO
19-Oct-11	07:48	16:41	47 45.00	122 45.00	08:09	HSEA	1	V	75/250	SW	125	S	1	Resight at 8:10 SW (south), resight at 8:12
19-Oct-11	07:48	16:41	47 45.08	122 43.49	08:10	HSEA	1	V	100/10	SW(S), DI	180	S	1	Heading south between Swift and EHW1
19-Oct-11	07:48	16:41	47 45.08	122 43.49	08:10	HSEA	1	V	160/282	SW(S), DI	200	S	1	Heading south NW of Scandia
19-Oct-11	07:48	16:41	47 44.97	122 43.59	08:13	HSEA	1	V	100/323	MI(S), SI	100	PC	1	
19-Oct-11	07:48	16:41	47 45.01	122 43.46	08:17	HSEA	1	V	25/360	SW, DI	300	S	1	
19-Oct-11	07:48	16:41	47 44.96	122 43.54	08:25	HSEA	1	V	150/220	SW(W), DI	300	PC	1	
19-Oct-11	07:48	16:41	47 45.06	122 43.49	08:29	OTHR	1	V	300/278	TR(S)	350	S	1	Unidentified sea lion heading south, too far to id-probably CASL, duck saw also no id
19-Oct-11	07:48	16:41	47 45.01	122 43.46	08:30	HSEA	3	V	100/60	SW(S), LO	100	S	1	LO at 8:31, 2 LO at 8:42
19-Oct-11	07:48	16:41	47 45.01	122 43.46	08:31	HSEA	1	SSV	100/160	SW(N), DI	250	S	1	
19-Oct-11	07:48	16:41	47 45.01	122 43.46	08:42	HSEA	2	V	200/175	UN	250	S	1	Seemed to be messing with buoy line. Rolling over each other and on top of line. Flipper up occasionally.
19-Oct-11	07:48	16:41	47 45.07	122 43.47	08:55	HSEA	1	V	25/307	SW(S), DI	140	S	1	Small dark animal
19-Oct-11	07:48	16:41	47 44.98	122 43.61	09:39	HSEA	1	NA	75/300	SW(N), DI(N)	150	PC	1	
19-Oct-11	07:48	16:41	47 45.00	122 44.29	09:48	STSL	1	V	50/150	LO, DI(270)	910	S	1	*Emily focal follow #1, watched since it went outside WRA fence, changed directions a couple of times, orange patrol boat sped by ~100m away right at last sighting
19-Oct-11	07:48	16:41	47 45.01	122 43.46	10:01	HSEA	1	V	200/40	SW(E)	250	S	1	
19-Oct-11	07:48	16:41	47 45.08	122 43.48	10:03	HSEA	2	V	30/260	SW(S), DI	100	S	1	~40m apart, both moving south
19-Oct-11	10:20	16:41	47 44.58	122 44.00	10:20	CASL	2	SSV	10/SE	VO, PL, SW	2000	S	0	In water and playing during full vibe. Behavior normal and unchanged
19-Oct-11	07:48	16:41	47 45.01	122 43.46	11:05	HSEA	1	V	150/60	SW(S), SI, DI, OT	300	S	1	11:18 SW, SI, DI. 11:19 OT, swam in circles
19-Oct-11	07:48	16:41	47 45.23	122 43.48	11:37	HSEA	1	V	40/359	SW(S), DI	80	S	1	Heading south, moved into EHW1
19-Oct-11	07:48	16:41	47 44.99	122 43.55	13:03	HSEA	1	V	40/285	SW(S), DI	420	PC	1	Heading south, same small animal sighted west of EHW1-have been following his movements south as we repositioned over to TPP.
19-Oct-11	07:48	16:41	47 45.08	122 43.43	13:58	HSEA	1	V	30/170	LO, SI	170	OC	1	
19-Oct-11	07:48	16:41	47 45.02	122 43.66	14:00	CASL	1	V	60/134	TR(S)	160	C	2	Heading south
19-Oct-11	07:48	16:41	47 45.01	122 44.29	14:29	HSEA	1	V	25/067	LO, SW(67)	900	OC	2	
19-Oct-11	07:48	16:41	47 45.01	122 43.45	14:40	HSEA	1	V	250/195	SW(SW), DI(SW)	375	OC	1	
19-Oct-11	07:48	16:41	47 45.02	122 43.64	14:50	HSEA	1	V	40/84	SW(S), DI	100	C	2	Heading south

Date:	Time Observation Initiated: (hh:mm)	Time Observation Completed: (hh:mm)	Latitude	Longitude	Sighting Time (hh:mm)	Species	# of Anim(s)	Const. Type	Est. Dist. (m)/ Dir. to Ani(s)*	Behavior Type	Est. Dist. to Pile (m)**	Weather Conditions	Beaufort	Notes
19-Oct-11	07:48	16:41	47 45.08	122 43.43	16:09	HSEA	9	V	150-500/150-160	SW, DI, RE	300-500	OC	1	9 animals all SW (north), group of 5, group of 3 and 1 in the lead. 16:11 1 RE, 16:12 4 nearing EHW pier, 16:13 2 SW (south), 16:32 2 RE about 100m apart, 16:37 1 SW (north)
19-Oct-11	07:48	16:41	47 45.00	122 43.60	16:18	HSEA	1	V	140/154	SW(SW), LO, DI	100	C	2	Heading south
20-Oct-11	07:57	16:05	47 45.00	122 43.45	08:00	HSEA	1	NA	30/200	SW(NW)	175	OC	1	Resighted this animal alone from 8:03 till 8:31. See data sheets for detailed observations.
20-Oct-11	07:57	16:05	*		08:01	HSEA	3	NA	*	RE	NA	OC	0	Delta WRA fence count, 3 HSEA on fence buoys
20-Oct-11	07:57	16:05	*		08:01	CASL	23	NA	*	RE	NA	OC	0	Delta WRA fence count, 23 CASL on fence buoys
20-Oct-11	07:57	16:05	47 45.00	122 43.45	08:03	HSEA	1	NA	120/185	SW(N), LO, SI	250	OC	1	Juvenile. Resighted this animal alone from 8:07 till 8:36. See data sheet for detailed observations.
20-Oct-11	07:57	16:05	47 45.07	122 43.42	08:06	HSEA	1	NA	75/202	SW(S), SI	75	OC	0	
20-Oct-11	07:57	16:05	47 44.63	122 43.90	08:10	CASL	2	NA	15/N	FO	900	C		
20-Oct-11	07:57	16:05	47 45.48	122 45.25	08:13	HSEA	1	V	30/333	LO, SI	NA	OC	0	Small HSEA near acoustic buoy (rubber ducky)
20-Oct-11	07:57	16:05	47 45.00	122 43.45	08:29	HSEA	1	V	30/190	SW(S)	150	OC	1	Large/more grey animal. This animal sighted with #2. Resighted until 8:39.
20-Oct-11	07:57	16:05	47 45.07	122 43.42	08:30	HSEA	2	V	25/89	SW(S), DI(S)	200	OC	0	
20-Oct-11	07:57	16:05	47 45.00	122 43.55	08:31	HSEA	1	V	80/273	SW(E), DI	80	C	1	Heading east
20-Oct-11	07:57	16:05	47 45.07	122 43.42	08:33	HSEA	1	V	225/305	SW(S), DI(S)	400	L, OC	0	
20-Oct-11	07:57	16:05	47 44.63	122 43.90	08:39	CASL	17	V	15/N	RE	900	C	0	Crane moving, no effect.
20-Oct-11	07:57	16:05	47 44.63	122 43.90	08:40	CASL	17	V	15/N	RE	900	C	0	No change in behavior.
20-Oct-11	07:57	16:05	47 44.58	122 44.00	08:40	CASL	1	V	8/SE	UN	2000	C	0	(tp9-3) CASL is half on the package and submerging its head and surfacing, scratching
20-Oct-11	07:57	16:05	47 45.00	122 43.45	08:41	HSEA	4	SSV	50/185	SW(N), LO, SI	350	OC	1	All grouped together SW north. 8:43 2 sighted SW (north). 8:44 2 sighted SW (north)
20-Oct-11	07:57	16:05	47 44.63	122 43.90	08:42	CASL	17	SSV	15/N		900	C	0	No change in behavior.
20-Oct-11	07:57	16:05	47 44.63	122 43.90	08:43	CASL	17	SSV	15/N		900	C	0	No change in behavior.

Date:	Time Observation Initiated: (hh:mm)	Time Observation Completed: (hh:mm)	Latitude	Longitude	Sighting Time (hh:mm)	Species	# of Anim(s)	Const. Type	Est. Dist. (m)/ Dir. to Ani(s)*	Behavior Type	Est. Dist. to Pile (m)**	Weather Conditions	Beaufort	Notes
20-Oct-11	07:57	16:05	47 45.00	122 43.45	08:45	HSEA	4	V	75/125	SW, SI, DI	300	OC	1	Same animals as #4. Vibratory hammer on. 8:45 1 SW (n). 8:46 2 sighted SW(n). 8:48 2 sighted SW south and diving. 8:49 1 animal much further north still swimming north. 8:51 2 animals swimming south and approaching marginal pier. 8:53 1 sighted by the pier. 8:55 1 animal swimming south. To summarize: the animals were first sighted when SS began. They were in a group of 4 while swimming north. They split up and one headed north while two were seen together heading south and minutes later the fourth animal was seen swimming south.
20-Oct-11	07:57	16:05	47 44.63	122 43.90	08:45	CASL	17	V	15/N		900	C	0	No change in behavior.
20-Oct-11	07:57	16:05	47 44.99	122 43.55	08:47	HSEA	1	V	250/304	SW(NE)	170	C	1	Heading northeast, lost sight behind barge
20-Oct-11	07:57	16:05	47 44.58	122 44.00	08:50	CASL	1	V	8/SE	EW	2000	C	0	CASL entered water from package to play/fight with the CASL in the water already (sighting #1)
20-Oct-11	07:57	16:05	47 44.99	122 43.55	08:52	HSEA	1	V	140/236	SW(S), DI	200	C	1	Heading south, no behavior observed
20-Oct-11	07:57	16:05	47 44.63	122 43.90	08:54	CASL	18	V	15/N	RE, SW, HO	900	C	0	+1 CASL from west SW, then HO.
20-Oct-11	07:57	16:05	47 44.99	122 43.56	09:06	HSEA	2	V	100/216	SW(SE), LO, DI	190	L, F	1	Heading southeast towards marginal pier
20-Oct-11	07:57	16:05	47 45.03	122 44.24	09:07	OTHR	1	V	200/322	SI	NA	OC	0	Probable HSEA
20-Oct-11	07:57	16:05	47 45.07	122 43.42	09:24	HSEA	1	V	75/77	SW(S), DI(S)	250	L, F, OC	0	Light rain, fog, overcast
20-Oct-11	07:57	16:05	47 45.00	122 43.45	09:31	HSEA	3	NA	200/190	SW(S)	300-600	OC	1	These animals are in addition to sighting #4. There were approximately 7 animals in the area. All these animals were observed until 10:46 for the next soft start. Notes on data sheet provide detailed observations.
20-Oct-11	07:57	16:05	47 45.00	122 43.45	10:46	HSEA	2	SSV	75/95	LO, SI	300	OC	1	
20-Oct-11	07:57	16:05	47 44.63	122 43.90	10:46	CASL	23	SSV	15/N	RE	900	L	0	Vibe on, no effect.
20-Oct-11	07:57	16:05	47 44.63	122 43.90	10:46	CASL	25	SSV	15/N	SW, DI	900	L	0	+2 CASL from west SW/DI. No effect.
20-Oct-11	07:57	16:05	47 44.58	122 44.00	10:47	CASL	2	SSV	8/SE	EW, UN	2000	C	0	2 CASLs entered the water as part of their play/fighting activities. No change in behavior, seemed normal and unaffected
20-Oct-11	07:57	16:05	47 45.00	122 43.45	10:48	HSEA	2	SSV	75/95	SW(S)	300	OC	1	

Date:	Time Observation Initiated: (hh:mm)	Time Observation Completed: (hh:mm)	Latitude	Longitude	Sighting Time (hh:mm)	Species	# of Anim(s)	Const. Type	Est. Dist. (m)/ Dir. to Ani(s)*	Behavior Type	Est. Dist. to Pile (m)**	Weather Conditions	Beaufort	Notes
20-Oct-11	07:57	16:05	47 45.00	122 43.45	10:51	HSEA	2	V	75/95	LO, SI, DI, SW, SL, UN, BR	300	OC	1	10:52 splashing around and rolling over one another. 10:55 SW south. 10:57 a complete "pinniped" breach, possibly landing on the other seal. 10:59 one animal lifted its head similar to a spy hop in cetaceans. Slammed down on water. 11:00 SW south. To summarize: it is important to note that these animals were doing the same thing prior to SS and v. The behavior seemed a bit more intensified while the vibratory hammer was on. Also, these two animals did stop their activity and look and sink (see #6 sighting) with the first SS. The 3rd SS they were seen swimming and then they resumed their behaviors that they were doing prior to any construction activity.
20-Oct-11	07:57	16:05	47 45.07	122 43.42	10:57	HSEA	1	V	25/15	SW(N), DI(N)	200	L, F, OC	1	
20-Oct-11	07:57	16:05	47 44.63	122 43.90	11:42	CASL	27	SSV	15/N	RE, SW	900	L	1	23 RE, 4 SW. No effect.
20-Oct-11	07:57	16:05	47 44.63	122 43.90	12:28	CASL	24	NA	15/N	RE, SW	900	R	2	22 RE, 2 SW. No effect.
20-Oct-11	07:57	16:05	47 44.63	122 43.90	14:04	CASL	24	V	15/N	RE	900	C	1	14:04, 24 RE, no effect.
20-Oct-11	07:57	16:05	47 45.09	122 44.22	14:14	CASL	2	V	432/038	RE		OC	2	Both hauled out on fence buoys, one a lot drier than the other, no response to vibrate on TPP4, no noticeable response to soft start, or vibrate on TPP3(15:22.35)
20-Oct-11	07:57	16:05	47 45.09	122 44.22	14:14	HSEA	1	V	282/067	RE		OC	2	Hauled out on fence buoys, very white coat (dry), no response to vibrate on TPP4, no noticeable response to soft start, or vibrate on TPP3(15:22.35)
20-Oct-11	07:57	16:05	47 44.94	122 43.47	14:36	HSEA	1	V	125/312	SW(NE), DI	100	C	1	Heading northeast
20-Oct-11	07:57	16:05	47 45.09	122 43.37	14:43	HSEA	1	V	20/350	RE, SI	325	OC	1	Appeared to be a juvenile
20-Oct-11	07:57	16:05	47 44.94	122 43.48	14:45	CASL	1	NA	500/348	TR(N)	430	C	1	Appeared to be heading north beyond EHW1
20-Oct-11	07:57	16:05	47 45.09	122 43.37	14:49	STSL	1	NA	325/240	SW(S)	300	OC	1	Swimming south around 4--5knots. Surfaced 3 times. Less than 150 meters west of the Construction crew barge. From 15:03 to 15:06 we believe this same animal hauled up on the north submarine.
20-Oct-11	07:57	16:05	47 44.94	122 43.48	14:53	HSEA	1	V	40/294	SW(N), LO, SI	130	C	1	Heading north then sank, smaller animal
20-Oct-11	07:57	16:05	47 45.04	122 43.33	15:20	OTHR	1	V	600/314	SL, DI	470	C	1	Too far to id, saw thrash near patrol boat, color of pectoral flipper likely CASL
20-Oct-11	07:57	16:05	47 45.12	122 43.34	15:21	HSEA	1	V	20/297	LO(E), SI	130	OC	1	



Date:	Time Observation Initiated: (hh:mm)	Time Observation Completed: (hh:mm)	Latitude	Longitude	Sighting Time (hh:mm)	Species	# of Anim(s)	Const. Type	Est. Dist. (m)/ Dir. to Ani(s)*	Behavior Type	Est. Dist. to Pile (m)**	Weather Conditions	Beaufort	Notes
20-Oct-11	07:57	16:05	47 45.04	122 43.33	15:37	HSEA	1	V	10/314	LO, SI	120	C	1	Surfaced post vibe, looked at vessel then sank, resighted moving south along beach, at 15:48 looked then sank
20-Oct-11	07:57	16:05	47 45.05	122 43.33	15:50	HSEA	1	V	10/224	LO, MI, SI	110	C	1	At 15:50 near vessel looking then sank, very pale face, almost no spots on face
20-Oct-11	07:57	16:05	47 44.94	122 43.48	15:52	HSEA	1	V	200/50	SW(N)	350	OC	1	

\*Estimated distance and direction to animal from observer location.

\*\*Estimated animal distance to pile based on observer notes. Note: takes were calculated based on actual (corrected) animal distances to pile.

***THIS PAGE INTENTIONALLY LEFT BLANK***

## APPENDIX I

### Photos of Project Area



**Figure I-1. Delta Pier South and port security barrier.  
Photographed 12 October 2011 by A. Balla-Holden, U.S. Navy.**



**Figure I-2. Delta Pier North, looking towards EHW-1.  
Photographed 13 October 2011 by A. Balla-Holden, U.S. Navy.**





**Figure I-3. California sea lions (*Zalophus californianus*) on the port security barrier.  
Photographed 30 September 2011 by A. Balla-Holden, U.S. Navy.**



**Figure I-4. California sea lion (*Zalophus californianus*, left) and a branded Steller sea lion (*Eumetopias jubatus*, right) hauled out on a submarine at Delta Pier. Brand reads “102Y”. Photographed 13 October 2011 by A. Balla-Holden, U.S. Navy.**





**Figure I-5. California sea lions (*Zalophus californianus*) and a Steller sea lion (*Eumetopias jubatus*) on a submarine at Delta Pier. Photographed 14 October 2011 by A. Balla-Holden, U.S. Navy.**

***THIS PAGE INTENTIONALLY LEFT BLANK***