

Crosstalk Nuisance Trip Testing of Photovoltaic DC Arc-Fault Detectors

Jay Johnson, Mike Montoya, Armando Fresquez, Sig Gonzalez – Sandia National Laboratories

Chris Oberhauser, Ash Patel – Texas Instruments

To improve fire safety in PV systems, Article 690.11 of the 2011 National Electrical Code (NEC) requires photovoltaic (PV) systems on or penetrating a building to include a listed arc-fault protection device. Depending on the manufacturer, arc-fault circuit interrupters (AFCIs) are being deployed at the module-level, string-level, or array-level. Each arc-fault protection scheme has a different cost and arc-fault isolation capability. Module-level and string-level AFCI devices tout the ability to isolate the fault, identify the failed PV component, and minimize the power loss by selectively de-energizing a portion of the array. However, these benefits are negated if the arcing noise—typically used for arc-fault detection—propagates to parallel, unfaultered strings and cause additional AFCI devices on the PV array to trip. Sandia National Laboratories collaborated with Texas Instruments to perform nuisance trip scenarios.



Arc-Fault and Baseline Noise on Parallel Strings

The current spectrum was measured on two PV systems with different inverters to determine propagation behaviors of the current noise on the DC-side of the PV system. As shown below, the noise is clearly elevated across the spectrum for both strings when the arc-fault occurs.

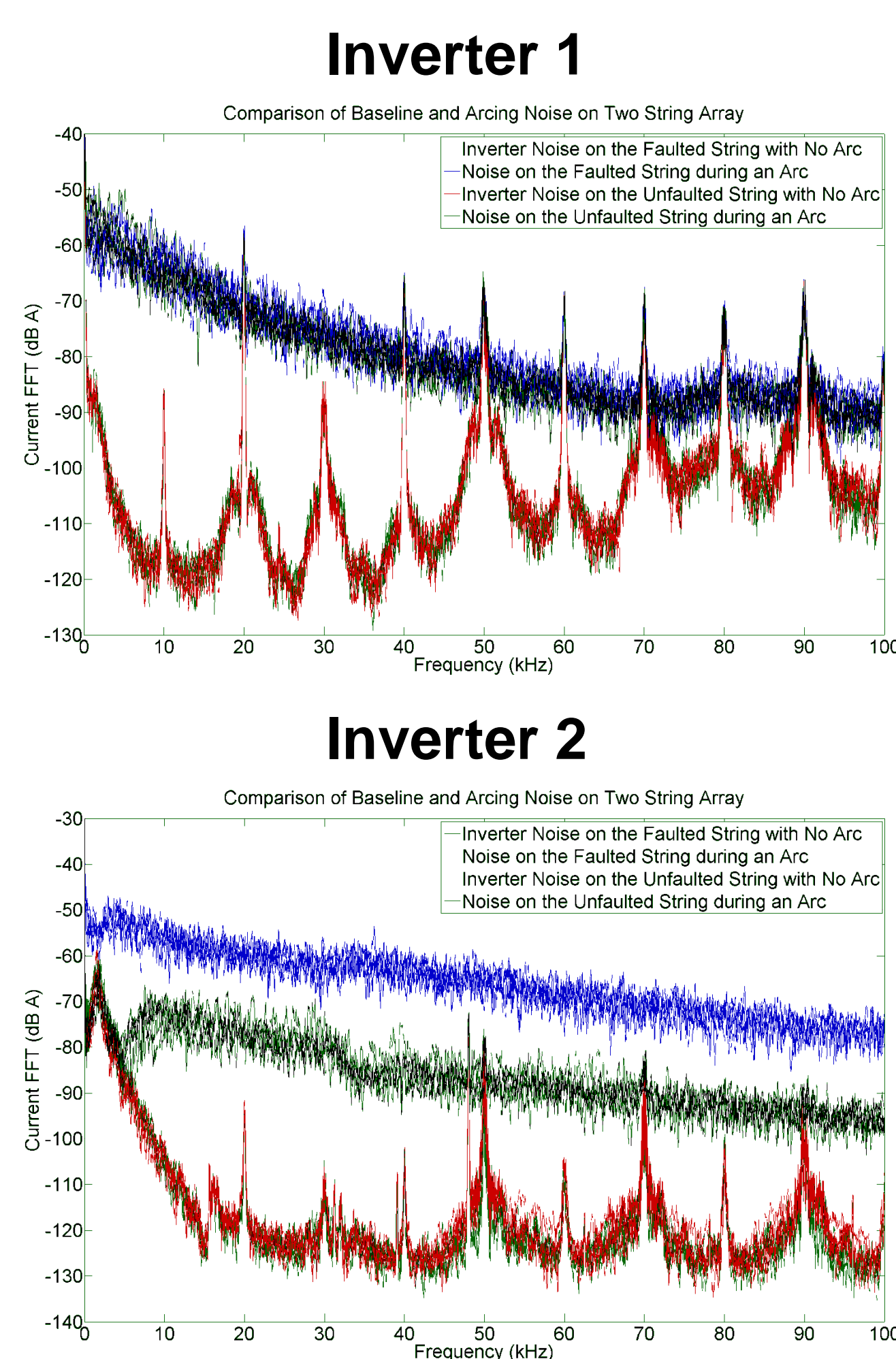

Baseline and arc-fault noise signatures on two PV systems with two strings of 7 200 W c-Si modules. The arc-faults were measured at different times.

Arc-Fault Detector Susceptibility to Crosstalk Noise

A series arc-fault was generated with Texas Instruments (TI) Arc-Fault Detectors on each string. The trip times were recorded for each detector. In all except one case the faulted string tripped before the unfaulted string. The AFD FFT algorithm is performed every 15 ms, so when the difference in the detection times is greater than 15 ms the faulted string AFD would trip off before the unfaulted string. For detection time differences less than 15 ms, it is possible that the unfaulted string could trip on the arc-fault.

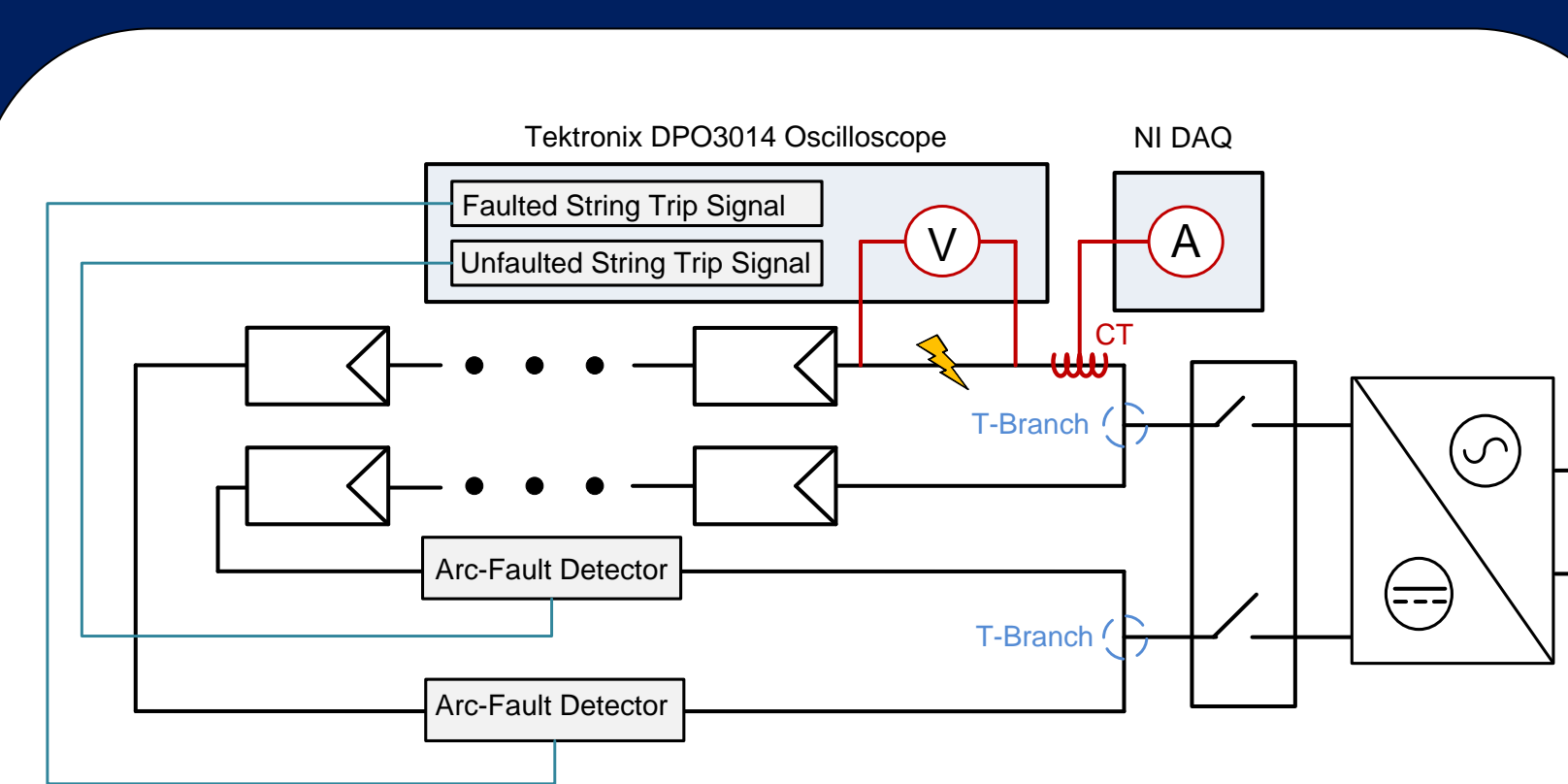

Crosstalk test setup on a two-string array with the data acquisition systems.

Test Number	Faulted String Trip Time (ms)	Unfaulted String Trip Time (ms)	Difference in Faulted and Unfaulted String Detection Times (ms)
1	29.4	63.3	33.9
2	50.9	82.5	31.6
3	52.6	75.3	22.7
4	35.3	64.0	28.7
5	59.0	87.7	28.7
6	52.2	80.7	28.5
7	40.8	68.7	27.9
8	76.7	79.6	2.9
9	63.8	70.0	6.2
10	82.5	76.1	-6.4
11	63.6	85.1	21.5
12	73.6	81.3	7.7

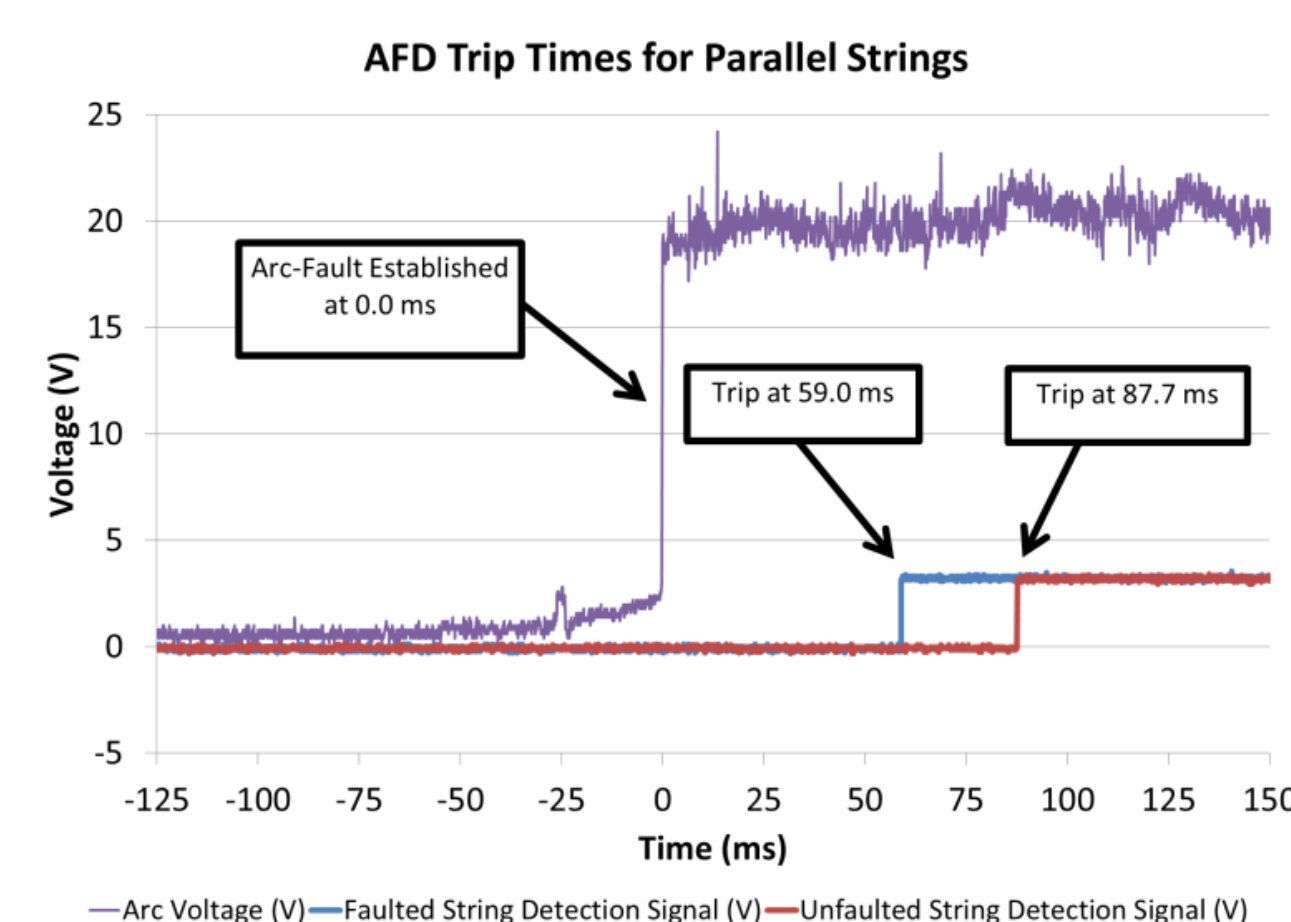

Faulted string de-energized first.

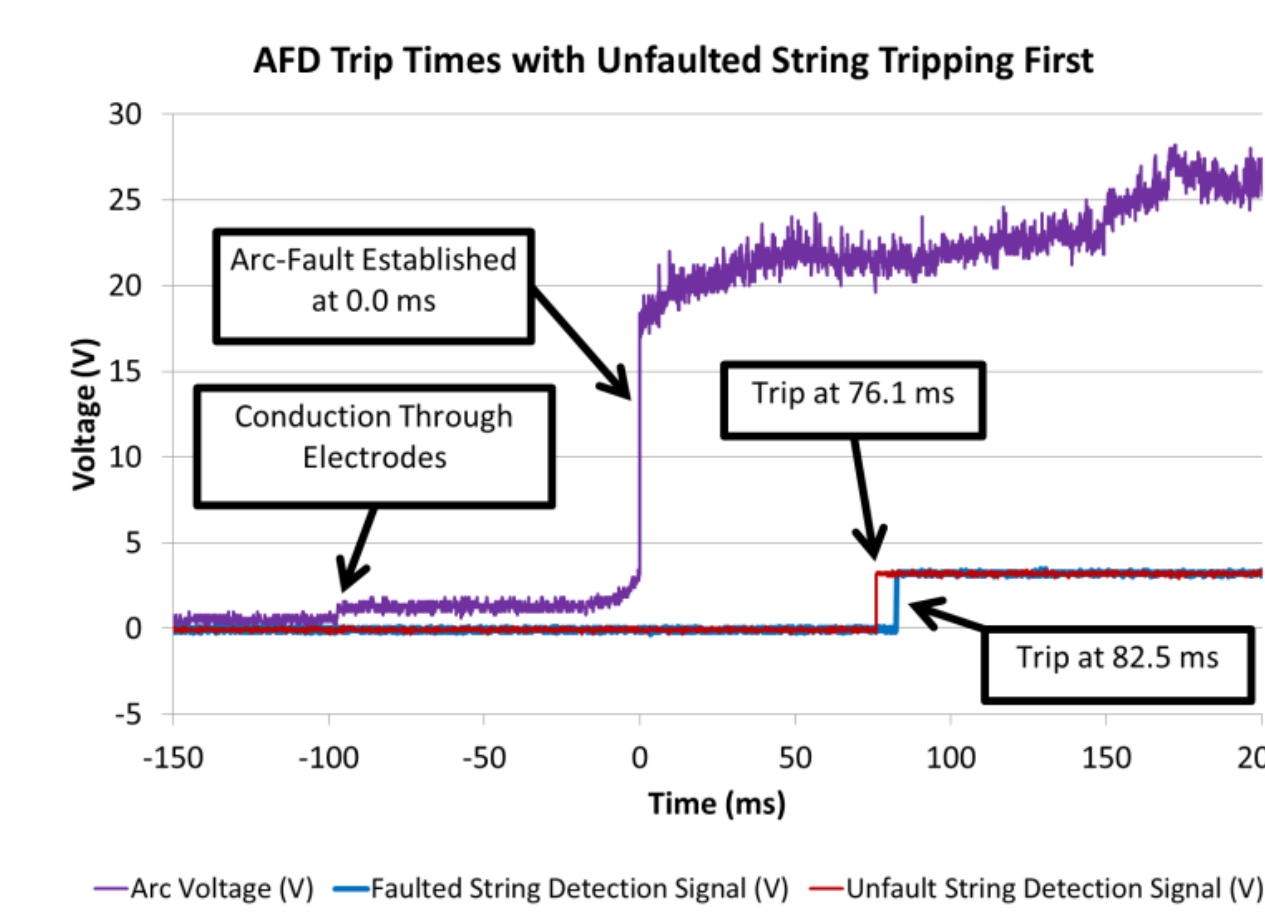

Unfaulted string de-energized first.

Experimental trip times for faulted and unfaulted strings. One example shows the arc-fault detector on the faulted string tripping first. The other shows the unfaulted AFD tripping before the faulted string.

Discussion

Experimental results on a 2-string array showed arc detection on the faulted string occurred an average of 19.5 ms before unfaulted string—but in some cases, the AFCIs on both strings would trip.

In one test the arc-fault detector on the unfaulted string tripped before the faulted string AFD. During this arc-fault test, both arc-fault detectors would have tripped and the location of the faulty component would not have been easily identified. Further, for the two-string system, there would be no advantage to using string-level detectors over one array-level detector. Yet, based on the trip time differences, in 8 of the 12 tests the AFD on the faulted string would have tripped first and the unfaulted string would not have tripped.

Texas Instruments believes adjustments to the arc-fault detector parameters would improve these results. With correct thresholding it may be possible to eliminate the crosstalk problem.

There also may be a limit to the crosstalk problem with larger PV systems because the arc-fault noise energy would propagate through a larger branch network. In that case, the energy would be more distributed and, therefore, less pronounced on each of the parallel branches.