

SAND REPORT

SAND2001-2375
Unlimited Release
Printed August 2001

NuMAD User's Manual

Numerical Manufacturing And Design tool

Daniel L. Laird
Wind Energy Technology

Prepared by
Sandia National Laboratories
Albuquerque, New Mexico 87185 and Livermore, California 94550

Sandia is a multiprogram laboratory operated by Sandia Corporation,
a Lockheed Martin Company, for the United States Department of
Energy under Contract DE-AC04-94AL85000.

Approved for public release; further dissemination unlimited.



Sandia National Laboratories

Issued by Sandia National Laboratories, operated for the United States
Department of Energy by Sandia Corporation.

NOTICE: This report was prepared as an account of work sponsored by an agency of the United States Government. Neither the United States Government, nor any agency thereof, nor any of their employees, nor any of their contractors, subcontractors, or their employees, make any warranty, express or implied, or assume any legal liability or responsibility for the accuracy, completeness, or usefulness of any information, apparatus, product, or process disclosed, or represent that its use would not infringe privately owned rights. Reference herein to any specific commercial product, process, or service by trade name, trademark, manufacturer, or otherwise, does not necessarily constitute or imply its endorsement, recommendation, or favoring by the United States Government, any agency thereof, or any of their contractors or subcontractors. The views and opinions expressed herein do not necessarily state or reflect those of the United States Government, any agency thereof, or any of their contractors.

Printed in the United States of America. This report has been reproduced directly from the best available copy.

Available to DOE and DOE contractors from
U.S. Department of Energy
Office of Scientific and Technical Information
P.O. Box 62
Oak Ridge, TN 37831

Telephone: (865)576-8401
Facsimile: (865)576-5728
E-Mail: reports@adonis.osti.gov
Online ordering: <http://www.doe.gov/bridge>

Available to the public from
U.S. Department of Commerce
National Technical Information Service
5285 Port Royal Rd
Springfield, VA 22161

Telephone: (800)553-6847
Facsimile: (703)605-6900
E-Mail: orders@ntis.fedworld.gov
Online order: <http://www.ntis.gov/ordering.htm>



SAND2001-2375
Unlimited Release
Printed August 2001

NuMAD User's Manual

Daniel L. Laird
Wind Energy Technology
Sandia National Laboratories
P.O. Box 5800
Albuquerque, NM 87185-0708

Abstract

Sandia National Laboratories has an on-going effort to reduce wind turbine blade cost through improved blade manufacturing techniques and design-for-manufacturing. As part of this effort, a new software tool named NuMAD (Numerical Manufacturing And Design) has been developed to greatly simplify the process of creating a three-dimensional finite element model for a modern wind turbine blade. NuMAD incorporates manufacturing guidelines as well as databases of airfoils, materials, and loadings to significantly reduce the time required for model creation. NuMAD is a stand-alone, user-friendly, windows based (graphical) pre-processor and post-processor for the ANSYS® commercial finite element engine. This user's manual describes the capabilities of NuMAD.

Contents

| | |
|---|----|
| <u>Figures</u> | 8 |
| <u>Glossary of Terms</u> | 14 |
| <u>CHAPTER 1 Introduction</u> | 16 |
| <u>1.1 Databases</u> | 17 |
| <u>1.1.1 Airfoils</u> | 17 |
| <u>1.1.2 Materials</u> | 17 |
| <u>1.2 Analyses/Loadings</u> | 17 |
| <u>1.3 Output</u> | 17 |
| <u>CHAPTER 2 Code Structure</u> | 18 |
| <u>2.1 NuMAD interaction with ANSYS</u> | 18 |
| <u>2.2 Directory Structure</u> | 19 |
| <u>2.2.1 Root NuMAD Directory</u> | 19 |
| <u>2.2.2 Ncore Directory</u> | 19 |
| <u>2.2.3 Help Directory</u> | 20 |
| <u>2.2.4 Job Directories</u> | 20 |
| <u>2.3 Upgrading to a newer version of ANSYS</u> | 20 |
| <u>2.3.1 Direct Modification of settings.txt File</u> | 21 |
| <u>2.3.2 Deletion of settings.txt File</u> | 22 |
| <u>CHAPTER 3 Interface Overview</u> | 24 |
| <u>3.1 Titlebar and Information Line</u> | 24 |
| <u>3.2 Main Menubar</u> | 24 |
| <u>3.2.1 File Menu</u> | 24 |
| <u>3.2.2 Airfoils Menu</u> | 25 |
| <u>3.2.3 Units Menu</u> | 25 |
| <u>3.2.4 Materials “Menu”</u> | 26 |
| <u>3.2.5 Blade Menu</u> | 26 |
| <u>3.2.6 Analysis, Loads, and Boundary Conditions Menus</u> | 26 |
| <u>3.2.7 Output and Execution Menus</u> | 26 |
| <u>3.2.8 Help Menu</u> | 26 |
| <u>CHAPTER 4 Airfoils Database</u> | 29 |
| <u>4.1 Location of Master Airfoil Profiles Database</u> | 29 |
| <u>4.2 Creating New Airfoil Profiles</u> | 29 |
| <u>4.3 Global versus Local Airfoil Profiles Database</u> | 31 |
| <u>CHAPTER 5 Materials Database</u> | 32 |
| <u>5.1 Location of Master Materials Database</u> | 32 |
| <u>5.2 Accessing the Master Materials Database</u> | 32 |
| <u>5.3 Adding a New Material Definition</u> | 34 |
| <u>5.3.1 Isotropic Material</u> | 34 |
| <u>5.3.2 Orthotropic Material</u> | 35 |
| <u>5.3.3 Composite Laminate Material</u> | 37 |
| <u>5.4 Deleting a Material Definition</u> | 43 |
| <u>5.4.1 Composites and Unused Isotropics and Layers</u> | 43 |

| | | |
|------------|---|-----|
| 5.4.2 | Isotropics and Layers Used in Composite Definitions | 44 |
| 5.5 | Modifying a Material Definition | 45 |
| 5.6 | Local Materials Database | 46 |
| CHAPTER 6 | Defining the Blade Model | 48 |
| 6.1 | Current Model | 48 |
| 6.1.1 | New Model | 48 |
| 6.1.2 | Opening an Existing Model | 48 |
| 6.2 | Define or Display Model | 50 |
| 6.2.1 | New Blade Geometry | 50 |
| 6.2.2 | Existing Blade Geometry | 55 |
| 6.3 | Modify Blade Model | 55 |
| 6.3.1 | Stations | 56 |
| 6.3.2 | Shear Webs | 65 |
| 6.3.3 | Spanwise Material Tapering | 68 |
| CHAPTER 7 | Loads and Boundary Conditions | 71 |
| 7.1 | Analysis Type | 71 |
| 7.1.1 | Mass Distribution | 71 |
| 7.1.2 | Modal | 71 |
| 7.1.3 | Static Structural | 71 |
| 7.1.4 | Eigenvalue Buckling | 72 |
| 7.2 | Specifying Loads | 72 |
| 7.3 | Boundary Conditions | 75 |
| CHAPTER 8 | Output | 76 |
| 8.1 | Graphical File Formats | 76 |
| 8.2 | ANSYS Data | 76 |
| 8.3 | Graphical Output | 77 |
| 8.4 | Mass Distribution | 79 |
| CHAPTER 9 | Launching the Analysis | 80 |
| 9.1 | Incomplete Data | 80 |
| 9.2 | Launching a Finite Element Analysis | 80 |
| 9.2.1 | Existing Model | 80 |
| 9.2.2 | Current Model | 81 |
| CHAPTER 10 | Example Blade Analysis | 83 |
| 10.1 | Creating a New Model | 83 |
| 10.1.1 | Specifying the Jobname | 83 |
| 10.1.2 | Selecting a System of Units | 84 |
| 10.2 | Airfoils | 85 |
| 10.3 | Material Properties | 87 |
| 10.3.1 | Layer Properties | 87 |
| 10.3.2 | Composite Material Definitions | 91 |
| 10.4 | Blade Geometry | 97 |
| 10.4.1 | Shear Webs | 110 |
| 10.4.2 | Blade Tip | 112 |
| 10.5 | Analysis Type, Loadings, Boundary Conditions | 113 |
| 10.6 | Graphical Output | 114 |
| 10.7 | ANSYS Launch | 115 |

| | | |
|-------------------|--|-----|
| <u>10.8</u> | <u>Results</u> | 115 |
| <u>CHAPTER 11</u> | <u>Summary</u> | 122 |
| <u>APPENDIX A</u> | <u>Graphical File Formats</u> | 123 |
| <u>A.1.</u> | <u>EPS – Encapsulated PostScript</u> | 123 |
| <u>A.2.</u> | <u>TIFF – Tagged Image File Format</u> | 124 |
| <u>A.3.</u> | <u>JPEG – Joint Photographic Experts Group</u> | 125 |
| <u>A.4.</u> | <u>Summary</u> | 126 |

Figures

| | | |
|----------------------------|--|----|
| Figure 2.1 | Diagram of interactions between NuMAD and ANSYS®. The user inputs such as geometry definition, material specifications, and model loadings are accomplished within NuMAD. After the ANSYS® FEA engine produces a solution, NuMAD extracts the desired output. | 18 |
| Figure 2.2 | NuMAD directory structure, the location of the root directory (NuMAD) is selected by the user. | 19 |
| Figure 2.3 | Contents of root NuMAD directory. | 19 |
| Figure 2.4 | Contents of typical job directory. | 20 |
| Figure 2.5 | The ANSYS® settings.txt file is located within the root NuMAD directory. | 21 |
| Figure 2.6 | The contents of the settings.txt file contains the paths to the ANSYS® executable, the DISPLAY executable and the ANSYS® product code. .. | 21 |
| Figure 2.7 | Dialog box prompting the user to specify the paths to ANSYS® and DISPLAY. The dialog only occurs if the settings.txt file is not present in the root NuMAD directory. | 22 |
| Figure 2.8 | Settings input dialog box for specifying the paths to ANSYS® and DISPLAY and for selecting the particular ANSYS® product. | 23 |
| Figure 3.1 | Initial screen with majority of pull-down menus inactive. | 24 |
| Figure 3.2 | “File” pull-down menu accessed from the main menubar. | 25 |
| Figure 3.3 | Selection of inch-based English system of units from the Units menu on the main menubar. | 26 |
| Figure 3.4 | Selection of NuMAD help system from the “Help” menu on the main menubar. | 27 |
| Figure 3.5 | HTML-based NuMAD help. | 27 |
| Figure 3.6 | HTML-based manufacturing tutorial. | 28 |
| Figure 4.1 | NuMAD directory structure, the location of the root directory (NuMAD) is selected by the user. | 29 |
| Figure 4.2 | Job directory structure with local airfoils directory. | 29 |
| Figure 4.3 | Sample airfoil profile with the clockwise coordinate numbering system. | 30 |
| Figure 4.4 | Sample airfoil profile definition file. | 30 |
| Figure 4.5 | Dialog box indicating that an airfoil present in the selected model is no longer present in the master airfoils database. | 31 |
| Figure 5.1 | Materials button on main NuMAD menubar. | 32 |
| Figure 5.2 | Master materials database window for isotropic, orthotropic, and composite materials. | 32 |
| Figure 5.3 | Master materials database window for fibers and matrix materials. | 33 |
| Figure 5.4 | Material properties display window for D155fv36CoRezyn63AX051. ... | 33 |
| Figure 5.5 | Composite laminate stack for comp3 which contains three layers of uniform thickness. | 34 |
| Figure 5.6 | Material properties display window for CoRezyn63AX051. | 34 |
| Figure 5.7 | Add Material menu, Isotropic selected. | 35 |
| Figure 5.8 | Dialog box used to define a new isotropic material. The values are input in the current system of units and displayed in two additional systems. .. | 35 |

| | | |
|-----------------------------|---|----|
| Figure 5.9 | Add Material Menu, Direct Definition Orthotropic Material (Layer) selected. | 35 |
| Figure 5.10 | Dialog box used for direct definition of a new orthotropic material. The values are input in the current system of units and displayed in two additional systems. | 36 |
| Figure 5.11 | Add Material Menu, Fiber/Matrix approximation for Orthotropic Material (Layer) selected. | 36 |
| Figure 5.12 | Dialog box used for fiber/matrix approximation of a new orthotropic material. The Halpin-Tsai equations are used to determine the orthotropic material properties. | 37 |
| Figure 5.13 | Add Material menu, Composite laminate selected. | 38 |
| Figure 5.14 | Dialog box used to begin definition of a new composite laminate material. | 38 |
| Figure 5.15 | Input window used to add a layer to a composite material definition. | 38 |
| Figure 5.16 | Schematic indicating the sense of the layer orientations. | 39 |
| Figure 5.17 | Schematic of ANSYS element SHELL99 displaying the element coordinate system. | 40 |
| Figure 5.18 | Schematic display of new composite laminate material definition after only one layer has been defined. | 41 |
| Figure 5.19 | Schematic display of composite laminate material definition after two layers have been defined. | 41 |
| Figure 5.20 | Input window used in the definition of a composite laminate material. The symmetry setting is “Even Symmetry.” | 42 |
| Figure 5.21 | Schematic display of composite laminate material definition after two layers have been defined for an even symmetric stack. | 42 |
| Figure 5.22 | Schematic display of composite laminate material definition after two layers have been defined for an odd symmetric stack. | 43 |
| Figure 5.23 | Deleting the “comp3” material from the master materials database. | 44 |
| Figure 5.24 | Confirmation dialog box to prevent accidental deletion of material definition. | 44 |
| Figure 5.25 | Error dialog box to indicate that no material is selected. | 44 |
| Figure 5.26 | Dialog box warning that the deletion of a particular orthotropic material (D155fv40) from the database will result in the deletion of four composite materials (comp1, comp98, compThin1, compThin2) from the database. | 45 |
| Figure 5.27 | Process to modify or duplicate the definition of the “D155fv36CoRezyn63AX051” material. | 45 |
| Figure 5.28 | Input window to modify or duplicate the definition of the material “D155fv36CoRezyn63AX051”. | 46 |
| Figure 5.29 | Warning dialog box indicating that a composite material (comp1) defined in the model is no longer present in the master (global) materials database. | 47 |
| Figure 6.1 | “New Model” entry selected from “File” menu. | 48 |
| Figure 6.2 | Dialog box for specifying a new job name. A directory (folder) with the job name is then created. | 49 |
| Figure 6.3 | “Open Existing Model” entry selected from “File” menu | 49 |

| | | |
|------------------------------------|---|----|
| <u>Figure 6.4</u> | <u>Dialog box for loading (opening) an existing NuMAD model. Any file may be chosen in the directory.</u> | 49 |
| <u>Figure 6.5</u> | <u>“Define” entry selected from “Blade” menu. The deactivated state of the other entries in the menu indicates that a new job name has been defined.</u> | 50 |
| <u>Figure 6.6</u> | <u>Dialog box to prevent accidental deletion of blade data.</u> | 50 |
| <u>Figure 6.7</u> | <u>Dialog box to select the method of external geometry input.</u> | 51 |
| <u>Figure 6.8</u> | <u>Dialog box to select the method of external geometry input. The option menu to select the number of coordinate pairs per station is active.</u> | 51 |
| <u>Figure 6.9</u> | <u>Initial “blade” created when a new model is being defined. The profiles used are the first profile in the master airfoil profiles database.</u> | 52 |
| <u>Figure 6.10</u> | <u>Dialog box to select the method of external geometry input, automatic external geometry generation in this case.</u> | 53 |
| <u>Figure 6.11</u> | <u>Dialog box to ensure desired units are selected before automatic external geometry generation begins.</u> | 53 |
| <u>Figure 6.12</u> | <u>Dialog box to select data set for automatic external geometry generation.</u> | 53 |
| <u>Figure 6.13</u> | <u>Schematic of blade model generated through automatic external geometry generation.</u> | 54 |
| <u>Figure 6.14</u> | <u>Menu used to reduce the number of coordinate pairs in files defining external blade geometry.</u> | 55 |
| <u>Figure 6.15</u> | <u>Input window to specify how to reduce number of coordinate pairs in files defining the external blade geometry.</u> | 55 |
| <u>Figure 6.16</u> | <u>“Display/Modify” entry selected from “Blade” menu. The active state of the other entries in the menu indicates that a blade geometry is currently in memory.</u> | 55 |
| <u>Figure 6.17</u> | <u>Blade geometry modification windows presented for a new blade model.</u> | 56 |
| <u>Figure 6.18</u> | <u>“Add New Station entry selected from the “Modify Blade Geometry” menu.</u> | 57 |
| <u>Figure 6.19</u> | <u>Dialog box allowing the user to cancel an “Add New Station” action.</u> | 57 |
| <u>Figure 6.20</u> | <u>Blade modification environment after the location of the new station has been selected.</u> | 58 |
| <u>Figure 6.21</u> | <u>Blade modification environment after the airfoil for the new station has been selected.</u> | 59 |
| <u>Figure 6.22</u> | <u>“Add Station” dialog box used to define numerous station parameters.</u> ... 59 | |
| <u>Figure 6.23</u> | <u>Station parameters used for example blade.</u> | 60 |
| <u>Figure 6.24</u> | <u>S808 profile divided into five material section by four skin material divisions.</u> | 60 |
| <u>Figure 6.25</u> | <u>Guide to materials defined for the current airfoil.</u> | 61 |
| <u>Figure 6.26</u> | <u>S808 profile with the fourth material section selected.</u> | 61 |
| <u>Figure 6.27</u> | <u>S808 profile after materials have been assigned to the five material sections.</u> | 62 |
| <u>Figure 6.28</u> | <u>Blade schematic of example blade after addition of first new station.</u> | 63 |
| <u>Figure 6.29</u> | <u>Blade schematic of example blade after addition of second new station (fourth total station).</u> | 63 |

| | | |
|-----------------------------|---|--------------------|
| Figure 6.30 | Screen shot of NuMAD as cursor passes over fourth station in the example blade. | 64 |
| Figure 6.31 | Blade schematic for blade example after four stations have been added or modified. | 65 |
| Figure 6.32 | Input window to specify parameters defining a new shear web. | 66 |
| Figure 6.33 | Selecting the beginning location of a shear web. | 66 |
| Figure 6.34 | Selecting the end location of a shear web. The shear web number is placed next to the shear web representation. | 67 |
| Figure 6.35 | Blade schematic for example after a shear web has been added. | 67 |
| Figure 6.36 | Selection of material section for spanwise material tapering. | 68 |
| Figure 6.37 | Input window allowing final layer thickness values to be specified. | 69 |
| Figure 6.38 | Portion of finite element model (red) selected to demonstrate the skin material “tapering” represented in | 69 |
| Figure 6.39 | Thickness representation (exaggerated) of composite material based on ANSYS real constant definitions. Twenty elements in direction of blade axis. | 70 |
| Figure 6.40 | Thickness representation (exaggerated) of composite material based on ANSYS real constant definitions. Four elements in direction of blade axis. | 70 |
| Figure 7.1 | Analysis menu with “Mass Distribution” and “Modal” selected. | 71 |
| Figure 7.2 | Loads menu, “# of Modes” entry selected. | 72 |
| Figure 7.3 | Input window for specifying the number of modes for a modal analysis. | 72 |
| Figure 7.4 | Loads menu, “Spin rate” entry selected. | 72 |
| Figure 7.5 | Input window to specify a blade spin rate. | 73 |
| Figure 7.6 | Loads menu, concentrated “Tip” load selected. | 73 |
| Figure 7.7 | Input window for concentrated tip load. | 73 |
| Figure 7.8 | Loads menu, “Hurricane” or distributed pressure load selected. | 74 |
| Figure 7.9 | Input window for specifying a distributed pressure load. | 74 |
| Figure 7.10 | Schematic of distributed pressure load on the underside (high pressure side) of blade. | 75 |
| Figure 7.11 | Boundary conditions menu with the cantilevered entry selected. | 75 |
| Figure 8.1 | “Output” menu from the main menubar. Both postscript and JPEG graphical output are selected. | 76 |
| Figure 8.2 | Example of default graphical output for tip load case. | 79 |
| Figure 9.1 | Warning issued if an analysis launch is attempted with no blade geometry definition. | 80 |
| Figure 9.2 | Launching a previously created model from the “File” menu. | 81 |
| Figure 9.3 | Starting an immediate ANSYS analysis from the “Execution” menu. | 81 |
| Figure 9.4 | Selecting a delayed ANSYS analysis from the “Execution” menu. | 82 |
| Figure 9.5 | Input window used to set the delay for ANSYS analysis. | 82 |
| Figure 9.6 | Countdown window used to provide the jobname and time until launch. | 82 |
| Figure 10.1 | “New Model” entry selected from the File menu. | 83 |
| Figure 10.2 | Dialog box for specifying a new NuMAD job name. In this example, the new job name is “pseudoSERI8.” | 84 |

| | | |
|-------------------------------------|---|-----|
| <u>Figure 10.3</u> | <u>Immediately after the specification of the NuMAD job name, all pull-down menus are active and the job name is displayed in the title bar of the main window.</u> | 84 |
| <u>Figure 10.4</u> | <u>“Units” menu with SI (mks) units selected.</u> | 85 |
| <u>Figure 10.5</u> | <u>Coordinate pairs defining the transitional airfoil “trans1.”</u> | 86 |
| <u>Figure 10.6</u> | <u>The “trans1” airfoil coordinate pairs transformed into NuMAD format.</u> | 86 |
| <u>Figure 10.7</u> | <u>Selection of the “Materials” button from the main menubar.</u> | 88 |
| <u>Figure 10.8</u> | <u>The materials database which appears after selection of the “Materials” button from the main menubar.</u> | 88 |
| <u>Figure 10.9</u> | <u>Menu path to add a new orthotropic material via direct definition of the material properties.</u> | 89 |
| <u>Figure 10.10</u> | <u>Input window to define a new orthotropic material by direct definition of properties.</u> | 89 |
| <u>Figure 10.11</u> | <u>Completed input window for new orthotropic material “Triax.”</u> | 90 |
| <u>Figure 10.12</u> | <u>Materials database with new layers added. The highlighted material is “Uni” and its properties are displayed.</u> | 91 |
| <u>Figure 10.13</u> | <u>Menu path to add a new composite material.</u> | 92 |
| <u>Figure 10.14</u> | <u>Input window for new composite material.</u> | 92 |
| <u>Figure 10.15</u> | <u>Selection of “Add New Layer” button from “Composite Material” window.</u> | 92 |
| <u>Figure 10.16</u> | <u>“Add Layer” input window for first layer of a new composite material.</u> | 93 |
| <u>Figure 10.17</u> | <u>Selection of orthotropic material for the first layer of a new composite definition.</u> | 93 |
| <u>Figure 10.18</u> | <u>Specification of layer thickness in “Add Layer” window.</u> | 94 |
| <u>Figure 10.19</u> | <u>The laminate schedule after the definition of the first layer. The layer number, thickness, and fiber orientation are listed at the left.</u> | 94 |
| <u>Figure 10.20</u> | <u>Laminate schedule after definition of the second layer. The name of each layer material is displayed and the total stack thickness is in the lower left.</u> | 95 |
| <u>Figure 10.21</u> | <u>Schematic of the viewing angle employed for the laminate schedule display of composite materials.</u> | 95 |
| <u>Figure 10.22</u> | <u>Completed laminate schedule for root material. Forty-six layers are defined.</u> | 96 |
| <u>Figure 10.23</u> | <u>Completed laminate schedule for material used in the trailing edge.</u> | 97 |
| <u>Figure 10.24</u> | <u>Selection of “Define” item from the Blade menu on the main menubar.</u> | 97 |
| <u>Figure 10.25</u> | <u>Selection of manual skin geometry generation. The total blade length and number of coordinate pairs per station are also specified through this window.</u> | 98 |
| <u>Figure 10.26</u> | <u>Initial “blade” schematic for manual blade skin geometry generation. The first profile in the airfoil database is used for the two stations.</u> | 98 |
| <u>Figure 10.27</u> | <u>Station properties displayed as cursor crosses the first station in the blade schematic.</u> | 100 |
| <u>Figure 10.28</u> | <u>Modified properties for station number one.</u> | 101 |
| <u>Figure 10.29</u> | <u>Selection of “Add New Station” from the “Modify Blade Geometry” menu.</u> | 102 |
| <u>Figure 10.30</u> | <u>Selection of “blade” section to add a new station.</u> | 102 |

| | | |
|------------------------------|---|-----|
| Figure 10.31 | Properties for the second station. Still in the root portion of the blade, the “airfoil” is circular. | 103 |
| Figure 10.32 | Blade schematic after addition of second station. | 104 |
| Figure 10.33 | Addition of third station, the first station using a true airfoil. | 105 |
| Figure 10.34 | Definition of first material section (red) for the third station. | 105 |
| Figure 10.35 | The third station (S808) divided into seven skin material sections. | 106 |
| Figure 10.36 | Selection of skin material section three for station three. Any previously defined composite material may be assigned to this material section. | 106 |
| Figure 10.37 | Selection of composite material “SparCap1” for skin material section three for station number three (S808). | 107 |
| Figure 10.38 | Completed skin material definitions for station number three. | 108 |
| Figure 10.39 | Blade schematic after definition of station number three has been completed. | 108 |
| Figure 10.40 | Initial skin material definitions for station four. | 109 |
| Figure 10.41 | Final blade schematic representation after all stations have been added and modified. | 109 |
| Figure 10.42 | Selection of “Add Shear Web” from the “Modify Blade Geometry” menu. | 110 |
| Figure 10.43 | Input window to add a shear web. Once a begin-station has been specified, the corresponding airfoil profile is displayed. | 110 |
| Figure 10.44 | Specification of shear web number one. The endpoints must be coordinates defining the airfoil. | 111 |
| Figure 10.45 | Blade schematic after definition of first shear web. | 111 |
| Figure 10.46 | Blade schematic after all shear webs have been defined. | 112 |
| Figure 10.47 | Selection of “Define Blade Tip Material” from the “Modify Blade Geometry” menu. | 112 |
| Figure 10.48 | Analysis pull-down menu with all analyses selected. | 113 |
| Figure 10.49 | Loads pull-down menu with Tip load selected. | 113 |
| Figure 10.50 | Input window used to specify concentrated tip loads. | 114 |
| Figure 10.51 | Input window used to specify distributed pressure loads. | 114 |
| Figure 10.52 | Boundary Conditions pull-down menu with cantilevered conditions selected. | 114 |
| Figure 10.53 | Graphical file format output pull-down menu with JPEG format. | 115 |
| Figure 10.54 | Analysis execution pull-down menu with immediate launch selected. | 115 |
| Figure 10.55 | Contents of jobname directory after completion of analysis for pseudoSERI8. | 116 |
| Figure 10.56 | Contents of subfolder (directory) pseudoSERI8/struct/tipload. | 117 |
| Figure 10.57 | Contents of subfolder (directory) pseudoSERI8/struct/tipload/jpg. | 117 |
| Figure 10.58 | Automatically created image <i>displace.jpg</i>. The tip displacement is 4.529 inches. | 118 |
| Figure 10.59 | Automatically created image <i>SkinLayer5bottomY.jpg</i>. Strains are in element Y directions at outer surface of layer 5. | 119 |
| Figure 10.60 | Automatically created image <i>ShearWebLayer4topeY.jpg</i>. Strains are in element Y directions at “top” surface of layer 4. | 120 |
| Figure 10.61 | Automatically created image <i>mode1b.jpg</i>. The mode shape is most visible in the upper view and the frequency is 4.91 Hz. | 121 |

Glossary of Terms

ANSYS Commercial finite element analysis software distributed by ANSYS, Inc., Canonsburg, PA.

axial Parallel to the blade axis, running from blade root to blade tip.

blade axis Line running the length of the blade and about which stations are positioned and rotated. May also be called the blade generator line.

blade generator line Line running the length of the blade and about which stations are positioned and rotated. May also be called the blade axis.

bottom Negative z-direction surface (element coordinate system) for shell elements or composite layers within elements, based on the order in which the nodes defining the element are defined. For shell99 elements comprising the blade skin of a model generated with NuMAD, the “bottom” surface is closer to the blade exterior than the “top” surface.

chord length Physical (non-normalized) distance from the nose to the tail of a given station.

EPS Encapsulated PostScript, vectorized graphical file format.

HTML HyperText Markup Language, the language of web pages.

inboard Towards the root end of the blade, opposite of outboard.

JPEG Joint Photographic Experts Group, highly compressed rasterized graphical file format.

layer Orthotropic materials used in the definition of a composite laminate stack. Properties are for the fiber and matrix combination.

nose Leading edge of an airfoil or station.

outboard Towards the blade tip, opposite of inboard.

real constant (set) A numbered set of constants (real values) used by ANSYS to describe various properties of an element. For a shell element, a real constant set will define the number of layers, the thickness of each layer, the material associated with each layer, etc.

spanwise Along the length of the blade from root to tip. Direction perpendicular to chordwise.

station Cross-section of blade at a particular distance from the blade root. The shape of the station may be an airfoil, root section, or transitional shape.

tail Trailing edge of an airfoil or station.

TIFF Tagged Image File Format, minimally compressed rasterized graphical file format.

top Positive z-direction surface (element coordinate system) for shell elements or composite layers within elements, based on the order in which the nodes defining the element are defined. For shell99 elements comprising the blade skin of a model generated with NuMAD, the “top” surface is closer to the blade interior than the “bottom” surface.

twist The rotation of a station about the blade generator line.

x-offset The distance from the “nose” of a station to the blade generator line.

CHAPTER 1 **Introduction**

Blades for modern wind turbines have changed dramatically over the last couple of decades. The scale of the blades has increased dramatically as well as the corresponding cost of the blades. This has resulted in more attention being given to blade design and analysis. While beam-models used in the past are sufficient in some instances, a more detailed finite element model of a wind turbine blade is often needed.

Sandia National Laboratories has an on-going effort to reduce blade cost through improved blade manufacturing techniques and design-for-manufacturing. The design portion of this effort requires the level of detail possible with three-dimensional finite element analysis but not possible with two-dimensional beam models. In addition, a tool is needed to simplify and expedite the creation and analysis of finite element models for wind turbine blades, including parametric studies. Manufacturing guidelines must be present from the beginning of the design process to avoid costly or impossible blade designs. To address these issues, Sandia National Laboratories has created a new software tool named NuMAD (Numerical Manufacturing And Design tool).

Though the commercial finite element (FE) analysis packages currently available are powerful, they are generally difficult to use. Even users well-versed in the finite element method can spend significant amounts of time deciphering the correct format in which to input data relating to anisotropic materials (laminated composites), varying thicknesses, etc. In addition, the minimum amount of information needed to properly define a wind turbine blade in three dimensions is non-trivial. As a result, experienced analysts may spend several weeks or months to develop a detailed finite element model of a turbine blade.

Other issues in model creation are reusability and design for manufacture. Depending on the methods used to develop the original model, subsequent modifications to the design may be relatively minor or quite time-consuming. Obviously, a process which maximizes model reusability would be beneficial, especially for parametric studies. Throughout the design process, manufacturing constraints should be incorporated. A design which cannot actually be produced is generally of limited interest.

A software tool, NuMAD, has been designed to address all of these issues and provide an improved finite element model development environment for wind turbine blades. NuMAD is a stand-alone, user-friendly, windows based (graphical) pre-processor and post-processor for the ANSYS[®] commercial finite element engine. Developed for the Windows2000[®] operating system, it is designed to enable users to quickly and easily create a three-dimensional model of a turbine blade and perform structural, modal, and eigenbuckling analyses. It is not a modified version of ANSYS[®] and may be run either independently to create ANSYS[®] input files for later batch execution or in conjunction with ANSYS[®] as a seamless interface. The parameters defining the blade may be provided by existing files (i.e. previous NuMAD models or station data sets) or developed interactively using databases of airfoil shapes and materials. Experience with the ANSYS[®] analysis package is not required but knowledge of finite element methods is

needed to use NuMAD effectively. No modification to the standard ANSYS® package is necessary.

A manufacturing tutorial is included in NuMAD to guide the design process in terms of manufacturability. Manufacturing error-checking is also present to warn users immediately of designs which may be difficult or costly to manufacture.

Model creation is aided by having available databases of materials, airfoils, and loading conditions. The databases are designed to be easily modified by the user. New materials may now be added through an interactive process designed to minimize ply orientation errors.

A brief overview of some of NuMAD's functionality follows.

1.1 Databases

In order to reuse data describing materials and airfoil shapes, databases for these areas are maintained within NuMAD. While the “stock” databases provided with NuMAD are relatively small, they are designed to be easily extended by end users. Thus, personalized databases are easily created.

1.1.1 Airfoils

The airfoils database consists of simple text files containing lists of x-y coordinate pairs describing the airfoil profiles. The airfoil names are contained in the filenames. Simply adding a text file with the correct format to the *airfoils* folder (directory) will make the new airfoil profile available within NuMAD.

1.1.2 Materials

The stock materials database uses data supplied by Montana State University. This database is constantly being extended and as with the airfoils database, it is easy to extend/customize. This database can be accessed and modified from within NuMAD, thus no external editor is needed.

1.2 Analyses/Loadings

The NuMAD user may select from any combination of static structural, modal, and eigenbuckling analyses. The static structural analyses include concentrated tip loads and distributed pressure loads. Boundary conditions are assumed to be cantilevered but for modal analyses the user may specify free-free boundary conditions.

1.3 Output

NuMAD provides the user with a default set of results in formats selected by the user. These results consist primarily of natural frequencies, mode shapes, and strains. To extract additional results, the user may interact with ANSYS® directly.

¹ ANSYS Inc., Southpointe, 275 Technology Drive, Canonsburg, PA 15317, <http://www.ansys.com>

CHAPTER 2 Code Structure

This chapter describes the directory structure employed by NuMAD, with emphasis on the issue of local versus master databases. While the NuMAD Programmer's Manual¹ discusses the workings of the code in detail, an overview is given here to assist the NuMAD user.

2.1 NuMAD interaction with ANSYS

Though designed to interface with ANSYS®, NuMAD is also a standalone application. This approach was chosen to minimize the amount of NuMAD modification needed to accommodate new releases of ANSYS®. If an integrated NuMAD/ANSYS® approach had been utilized, each new ANSYS® release would require a new NuMAD/ANSYS® package. The chosen approach also allows NuMAD to be utilized in the absence of ANSYS® to create files for later execution.

As indicated in Figure 2.1, NuMAD acquires the geometry, materials, and loadings from the user, launches an ANSYS® batch solution, then takes the results and presents them in a more readable form.

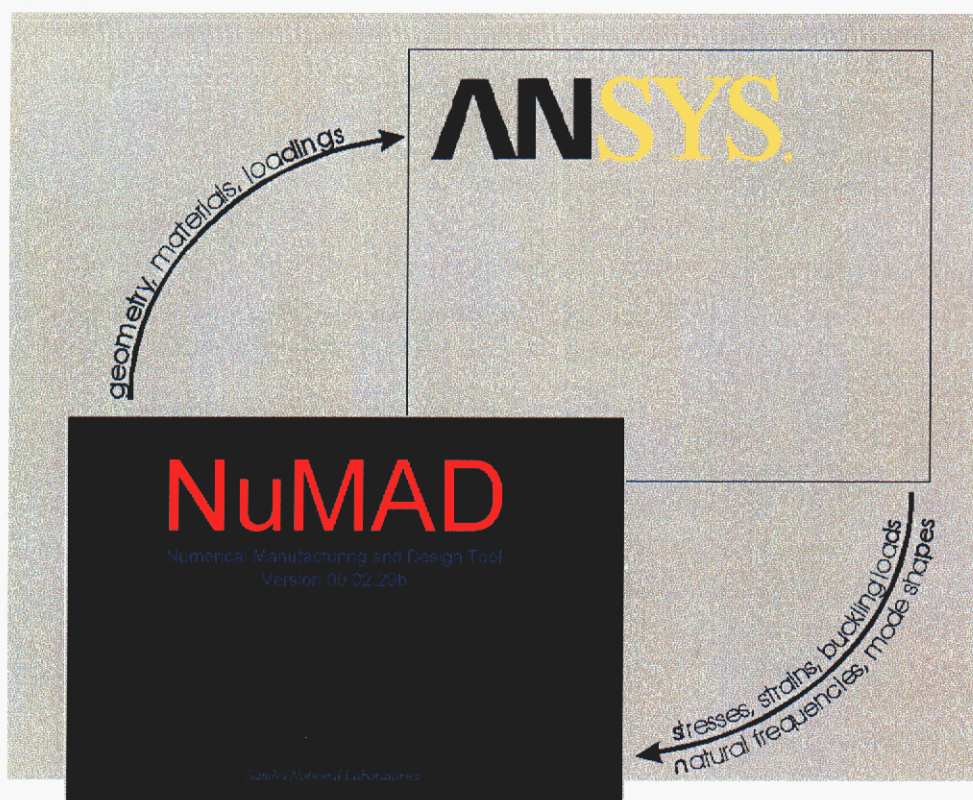

Figure 2.1 Diagram of interactions between NuMAD and ANSYS®. The user inputs such as geometry definition, material specifications, and model loadings are accomplished within NuMAD. After the ANSYS® FEA engine produces a solution, NuMAD extracts the desired output.

2.2 Directory Structure

The overall directory structure of NuMAD is relatively simple as demonstrated in Figure 2.2. There are no limitations on where the user may place the code and there are no system-related files outside the root NuMAD directory.

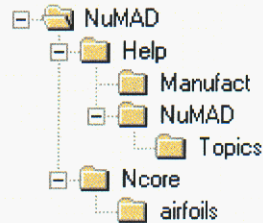

Figure 2.2 NuMAD directory structure, the location of the root directory (NuMAD) is selected by the user.

2.2.1 Root NuMAD Directory

The contents of the NuMAD root directory are shown in Figure 2.3. The file NuMAD.exe is the main executable. Shortcuts to NuMAD should be created from this file. The ReadMe.txt file contains information regarding the current release and settings.txt stores information regarding the existence and location of ANSYS® on the host machine. The file settings.txt will generally not exist immediately after NuMAD installation but will be created the first time NuMAD is launched. The Help System for NuMAD is located within the Help directory and numerous files used by NuMAD are located in the Ncore directory.

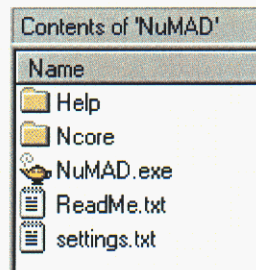

Figure 2.3 Contents of root NuMAD directory.

2.2.2 Ncore Directory

This directory contains a subdirectory named *airfoils* that contains the files comprising the master airfoils database. The directory is discussed in more detail elsewhere. Numerous files in the Ncore directory are used by NuMAD/ANSYS® and are discussed in the NuMAD Programmer's Manual.

2.2.3 Help Directory

As indicated in Figure 2.2, the Help directory has two subdirectories, *Manufact* and *NuMAD*. The two subdirectories contain the figures and html files used by the help system. These files may be accessed by a browser outside of NuMAD by opening the files *NuMAD\Help\Manufact\index.htm* or *NuMAD\Help\NuMAD\index.htm*.

2.2.4 Job Directories

Each blade model created has its own jobname, chosen by the NuMAD user. This jobname is also the name of the directory where the data for the model is stored. The NuMAD user selects the location for the job directory and this location may be on any drive currently mapped on the host machine.

Figure 2.4 shows the contents of a typical blade model job directory. The airfoils subdirectory is a local copy of the master airfoils database created when the job is saved. This local airfoils database can be used to replace airfoil definitions removed from the master airfoils database and is discussed in section 4.3. The ANSmacro.lib file contains ANSYS® macros used by NuMAD. The files *COMPsi.xml*, *fibers.xml*, *ISO.xml*, *matrices.xml*, and *ORTHOsi.xml* contain a local copy of the materials database and are discussed in section 5.6. The data describing the blade, loadings, boundary conditions, output requests, system of units, and type of geometry generation are stored in the files *Sdata1.nmd* and *Sdata3.nmd*.

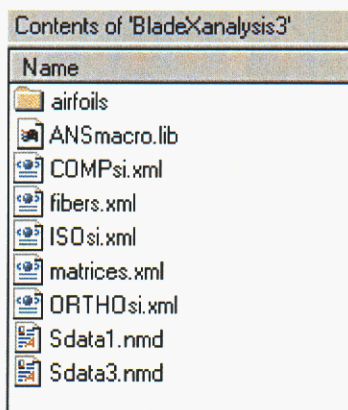

Figure 2.4 Contents of typical job directory.

2.3 Upgrading to a newer version of ANSYS

As mentioned previously, the NuMAD code is independent of ANSYS®. Thus to install a new ANSYS® release, simply follow the ANSYS® installation directions. The installation need not replace the previous ANSYS® installation if the user intends to use multiple versions. This is most likely when the user intends to test the new ANSYS® release before abandoning the previous release. After the new release of ANSYS® is installed, the settings.txt file must be modified.

Within the root NuMAD directory, a small file named *settings.txt* (Figure 2.5) maintains information about the ANSYS® product selected for use with NuMAD. This file does not exist when NuMAD is first installed but is created the first time NuMAD is launched.

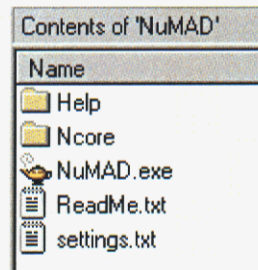

Figure 2.5 The ANSYS® *settings.txt* file is located within the root NuMAD directory.

Typical contents for the *settings.txt* file are shown in Figure 2.6. The first line simply signals the existence of ANSYS® on the host machine. In this case, “yes” indicates that ANSYS® exists on the host machine. If the first line of *settings.txt* were “no,” this would indicate that ANSYS® is not present on the host machine and the file, *settings.txt*, would end at this point. The second line indicates the path to the ANSYS® executable on the host machine. The third line indicates the path to the DISPLAY executable (DISPLAY is a graphics utility included with ANSYS) and the final line indicates the product code for the ANSYS® product. The product code “ANSYS” indicates the “ANSYS/Mechanical U” product while other codes correspond to the many variations of ANSYS® products. A full list of the ANSYS® product codes may be found in Appendix A of the ANSYS® Installation and configuration guide.

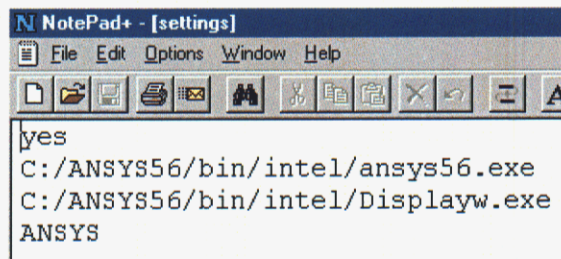

Figure 2.6 The contents of the *settings.txt* file contains the paths to the ANSYS® executable, the DISPLAY executable and the ANSYS® product code.

The *settings.txt* file must be modified to utilize a new release of ANSYS®. There are two methods to accomplish this task. The *settings.txt* file may be modified directly or the *settings.txt* file may be deleted and recreated automatically during the next launch of NuMAD.

2.3.1 Direct Modification of *settings.txt* File

The first approach to update *settings.txt* is to simply modify the contents of the *settings.txt* file with a text editor such as Notepad, or a word processor. The paths to the ANSYS® and DISPLAY executables should be changed to match the paths of the new

installation and the ANSYS® product code should correspond to the new ANSYS® product.

In many cases the modifications will be extremely minor. If, for instance, a new version of ANSYS® is installed over the old installation and the ANSYS® product is unchanged, the file contents shown in Figure 2.6 would need only one character modified. Namely, "... ansys56.exe ..." would change to "... ansys57.exe ..." Of course, if a different ANSYS® product has been installed, it is important to update the ANSYS® product code. An incorrect ANSYS® product code would prevent NuMAD from launching ANSYS®.

2.3.2 Deletion of settings.txt File

The second approach to update *settings.txt* is to delete the file from the root NuMAD directory and then complete the settings dialog box the next time NuMAD is launched.

When NuMAD is launched, it immediately searches for the existence of the *settings.txt* file. If it does not find the settings.txt file, NuMAD notifies the user that the ANSYS®-specific information must be supplied (Figure 2.7). In most cases, this is the result of a new NuMAD installation as indicated in the dialog box.

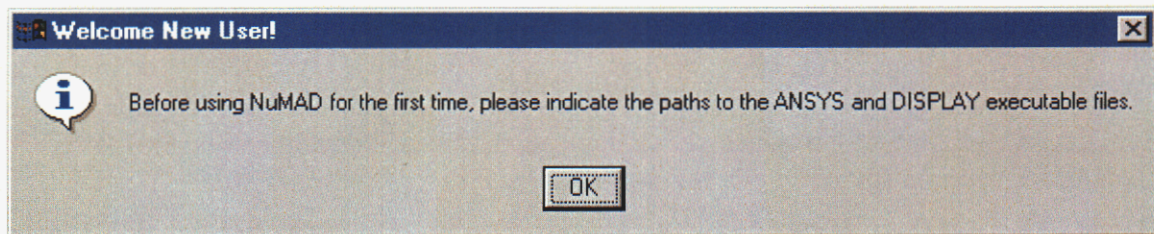

Figure 2.7 Dialog box prompting the user to specify the paths to ANSYS® and DISPLAY. The dialog only occurs if the *settings.txt* file is not present in the root NuMAD directory.

After accepting the dialog box shown in Figure 2.7, the user is presented with the large System Settings dialog box shown in Figure 2.8. This dialog box allows the user to specify the appropriate paths and ANSYS® product or the user may select the button at the bottom of the dialog box labeled "ANSYS is not installed on this machine." The latter option indicates to NuMAD that the host machine will only be used to create batch input files for ANSYS®. These files may be transferred to a different machine for execution.

In the case of a new ANSYS® installation, the NuMAD user would simply use the first "Browse" button to specify the path to the ANSYS® executable. NuMAD then searches for the DISPLAY executable in the same directory and automatically sets that path if possible. Then NuMAD searches for the ANSYS® license file on the host machine in an attempt to determine the ANSYS® product. If an ANSYS® license file is found, NuMAD automatically sets the ANSYS® product in the list of radio buttons shown in Figure 2.8. If more than one license file is present, NuMAD will select the most capable ANSYS® product. If the NuMAD user wishes to utilize a different ANSYS® product, the corresponding radio button may be manually selected.

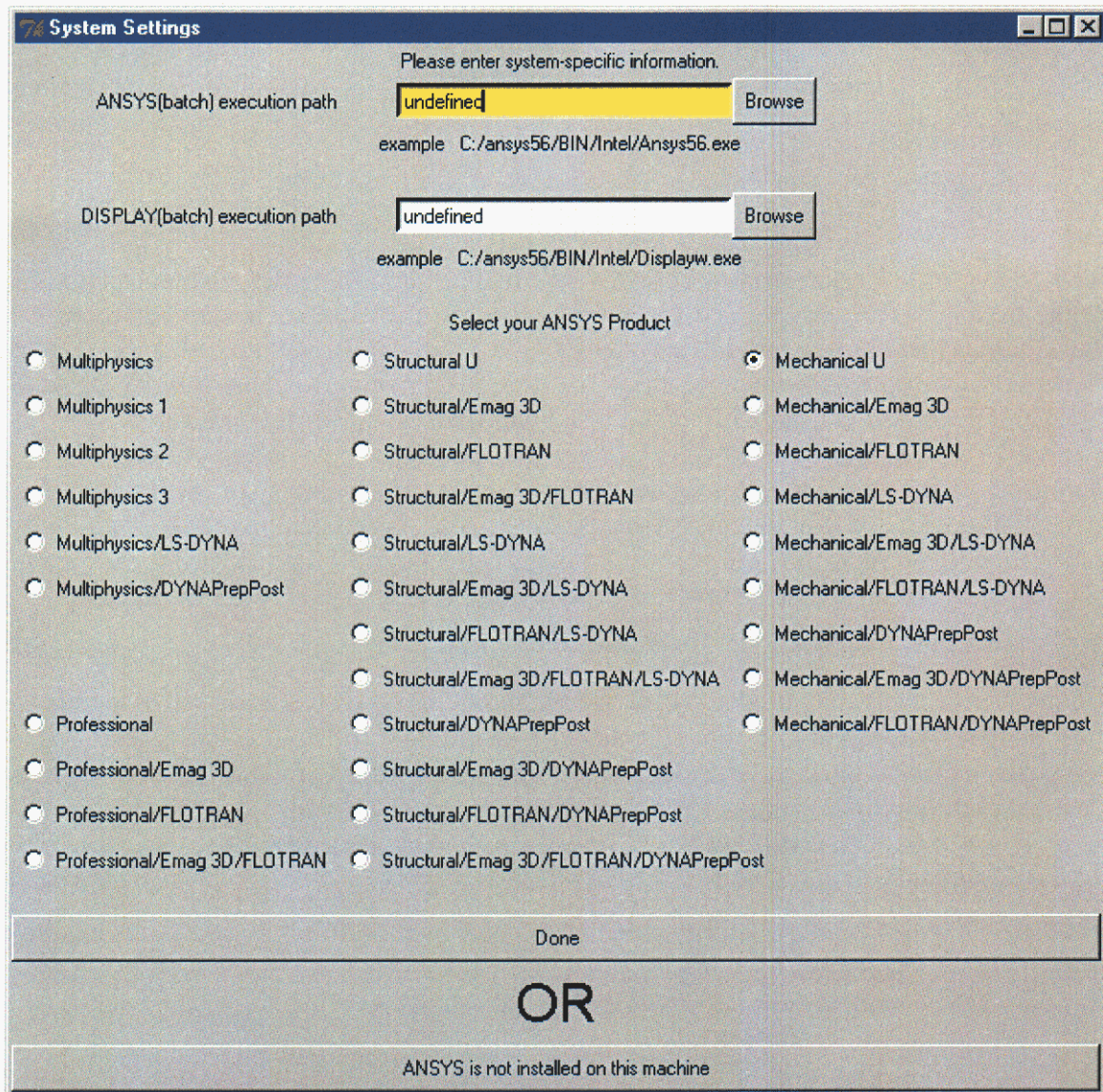

Figure 2.8 Settings input dialog box for specifying the paths to ANSYS® and DISPLAY and for selecting the particular ANSYS® product.

¹ Currently in progress, will be completed in late 2001.

CHAPTER 3 **Interface Overview**

NuMAD has a relatively standard graphical user interface consisting of menus, buttons, dialog boxes, etc. This chapter describes how NuMAD functionality is accessed through the interface.

3.1 Titlebar and Information Line

The titlebar of the main window contains information describing the version of NuMAD being used as well as model specific information. In the example shown in Figure 3.1, the first item on the titlebar is “NuMAD v.01.02.27b.” The versioning system used for NuMAD is the date of creation so the example just cited indicates that it was created on 2001, February, 27 and the “b” refers to a beta designation for the software. After the NuMAD version information, the NuMAD jobname is listed. When NuMAD is first launched, no jobname has yet been declared so “Unspecified” is displayed. The jobname is used to create a folder (directory) which contains all of the data related to a particular blade model. Next, the current system of units is displayed with mks being the default. Finally, the currently selected analysis type (modal is the default) is displayed as well as the number of modes to determine (if applicable).

Immediately below the titlebar is an information line. This area is used to display information relating to the model boundary conditions and to loading data. When NuMAD is first launched, the default boundary conditions are for the blade to be cantilevered from the root end of the blade.

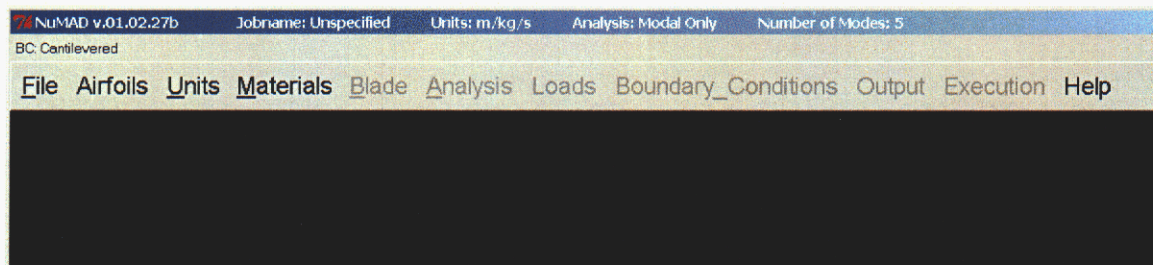

Figure 3.1 Initial screen with majority of pull-down menus inactive.

3.2 Main Menubar

Below the information line is the main NuMAD menubar (Figure 3.1). The menubar contains eleven pull-down menus which allow access to the full functionality of NuMAD. As indicated in Figure 3.1, many of the pull-down menus are not available until a jobname has been specified. Once a jobname has been set, all pull-down menus become active.

3.2.1 File Menu

The “File” pull-down menu handles tasks such as naming a new model, opening an existing model, saving a model or exiting NuMAD. This menu is shown in Figure 3.2.

The first item in the menu is “New Model.” This allows the user to specify a jobname for a new NuMAD model. Only after a jobname has been specified is most of NuMAD’s functionality available. The jobname is specified through a browse-type window which allows the user to easily select the path to the new jobname. A new folder (directory) is created with the jobname specified. An example of this process is presented in section 10.1.1.

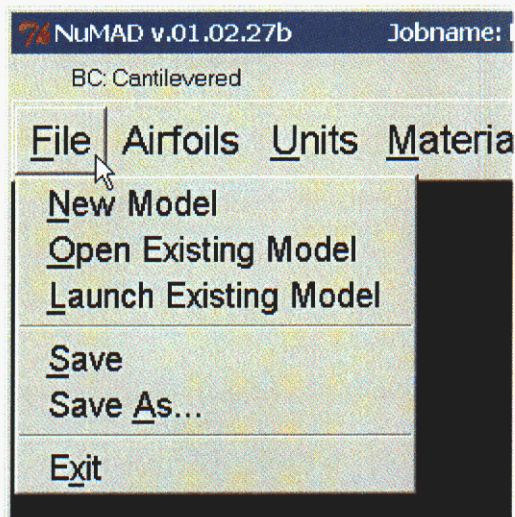

Figure 3.2 “File” pull-down menu accessed from the main menubar.

The next item in the menu is “Open Existing Model.” As expected, this allows the user to retrieve a previously created model and load it into memory. This is accomplished through a browse-type window.

The “Launch Existing Model” item opens an existing model and immediately launches the ANSYS® batch solution. The NuMAD interface will disappear once the ANSYS® batch solution has begun.

The “Save,” “Save As...,” and “Exit” items are all as the user would expect and comparable to the functionality in other software.

3.2.2 Airfoils Menu

This menu has only one item, “Reduce.” This is used to reduce the number of coordinate pairs defining airfoil profiles to be used for automatic blade geometry generation. A more detailed explanation is given in the context of defining the blade geometry in section 6.2.1.2.

3.2.3 Units Menu

The system of units used for a blade model may be set in the “Units” menu from the main menubar as indicated in Figure 3.3. The three systems available are SI (mks), foot-based English, and inch-based English. In Figure 3.3, the default current selection of mks units (indicated by the checkmark) is being changed to inch-based English units.

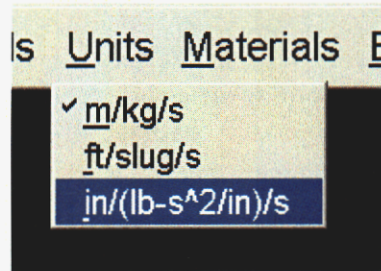

Figure 3.3 Selection of inch-based English system of units from the Units menu on the main menubar.

It should be noted that a global scaling capability exists (Blade Menu) so that the blade geometry may be input with a more convenient unit (i.e. mm) and then scaled into the standard unit (i.e. m).

3.2.4 Materials “Menu”

The “Materials” button on the main menubar actually causes a few independent windows to be displayed rather than just accessing a pull-down menu. These new windows represent the materials database and are discussed in detail in Chapter 5.

3.2.5 Blade Menu

The “Blade” pull-down menu allows a new blade geometry to be defined, an existing geometry to be displayed and modified, or an existing geometry to be scaled. The functionality available through this menu is the subject of Chapter 6.

3.2.6 Analysis, Loads, and Boundary Conditions Menus

These menus allow the user to select the type of analysis, the specific loadings corresponding to the analysis types, and the boundary conditions to be used for the model. These menus are described in Chapter 7.

3.2.7 Output and Execution Menus

The “Output” menu allows the user to select which graphical file formats will be used to create the standard output from NuMAD. This is discussed more in Chapter 8. The “Execution” menu allows the user to start the ANSYS® batch analysis immediately or at a set time in the future. This is described in Chapter 9.

3.2.8 Help Menu

The last menu on the main menubar is the “Help” menu (Figure 3.4). The first two items in this menu access the HTML-based NuMAD help system and manufacturing tutorial. The last item, “about,” simply gives the NuMAD version and contact information for the software.

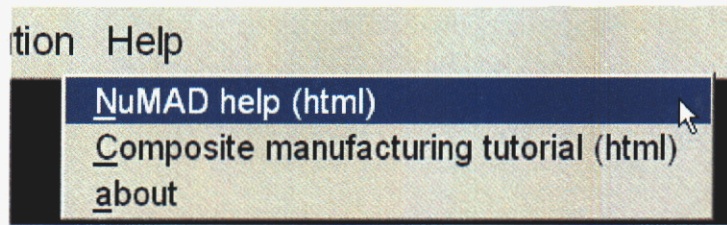

Figure 3.4 Selection of NuMAD help system from the “Help” menu on the main menubar.

The HTML-based NuMAD help system contains a more concise version of the information contained in this manual. When “NuMAD help (html)” is selected from the “Help” menu, the NuMAD help is launched with the default browser on the user’s system. Figure 3.5 shows the initial page in the NuMAD help. A long list of topics is hyperlinked to the corresponding information. This help system may also be accessed independently of NuMAD through *NuMAD/Help/NuMAD/index.htm*.

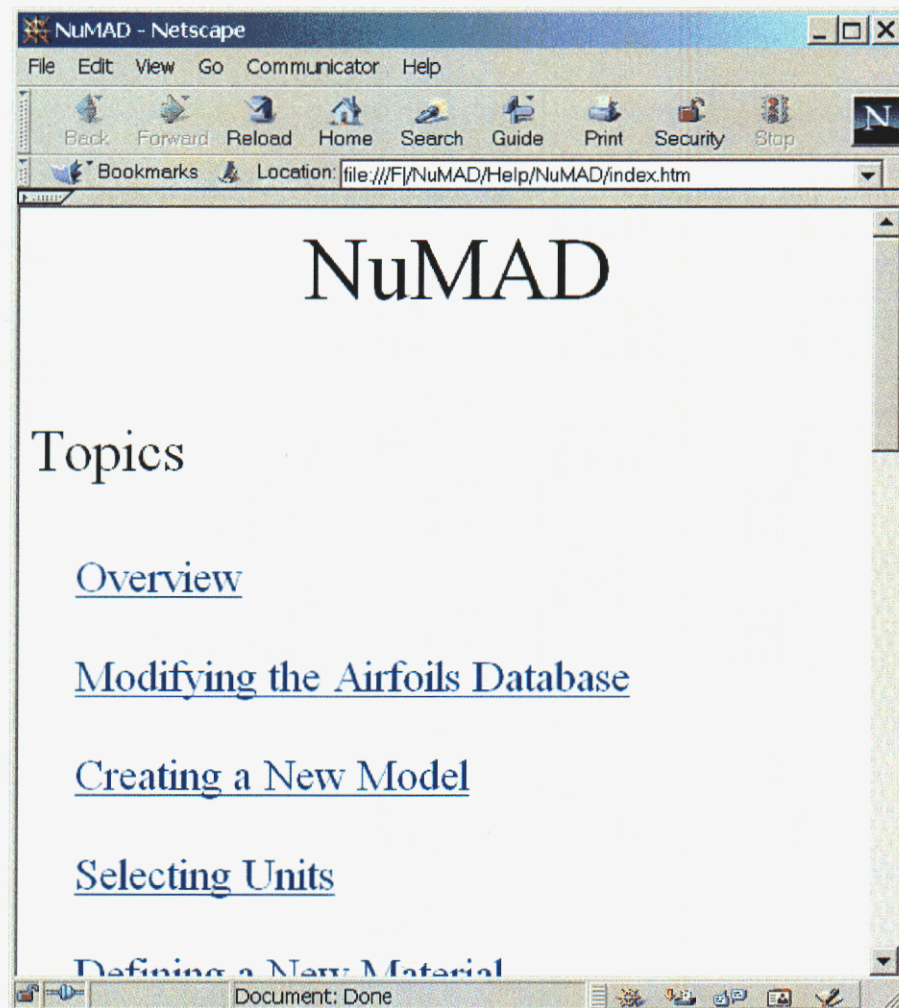

Figure 3.5 HTML-based NuMAD help.

The first page of the composite manufacturing tutorial is shown in Figure 3.6. This information contains general guidelines which can be used to improve the manufacturability of blade designs.

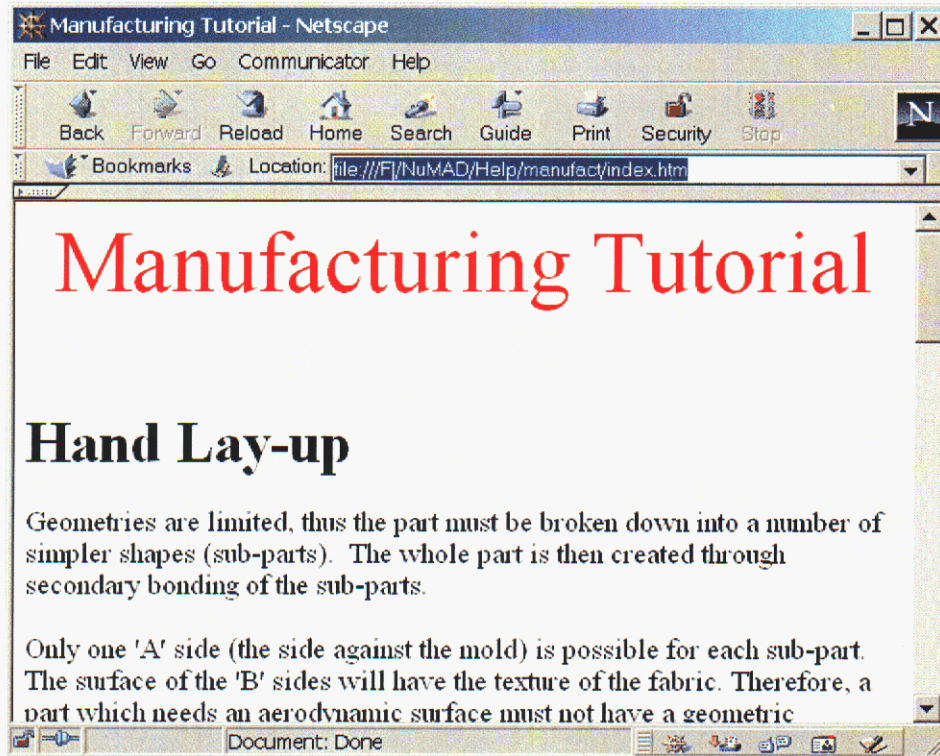

Figure 3.6 HTML-based manufacturing tutorial.

CHAPTER 4 **Airfoils Database**

NuMAD uses a database of airfoil profile descriptions so that this information need not be redefined with each new model. The airfoil profile descriptions are simple text files in an XML¹ format.

4.1 Location of Master Airfoil Profiles Database

The definitions for the airfoils in the master airfoil profiles database are contained in files which reside in a directory named *airfoils* which is a subdirectory of the directory *Ncore* (Figure 4.1). This group of files is called the master airfoils database because the information is available for all NuMAD models. In addition to the master airfoils database, each NuMAD model contains its own local airfoils database (Figure 4.2). The location of the local airfoils database is within a directory named *airfoils* within the root jobname directory.

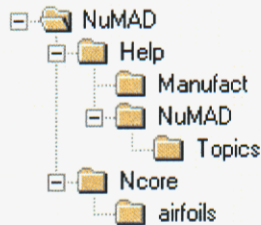

Figure 4.1 NuMAD directory structure, the location of the root directory (NuMAD) is selected by the user.

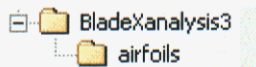

Figure 4.2 Job directory structure with local airfoils directory.

4.2 Creating New Airfoil Profiles

The database of airfoil definitions is a collection of text files where each file contains a normalized set of x-y coordinate pairs and the file name is the name of the airfoil. The x-y coordinate pairs are listed with one pair per line and one or more spaces separating the x-value from the y-value. All values are normalized such that the x-value of the nose is zero and the x-value of the tail is 1.0. For most standard airfoil shapes, the range of y-values will be bounded by the range -0.1 to +0.1. The first coordinate pair should define the location of the tail (i.e. 1.00 0.00) and the subsequent coordinate pairs should define the airfoil profile in a clockwise direction (Figure 4.3). The coordinate pair corresponding to the nose of the profile should be near the middle of the list. The last coordinate pair should NOT duplicate the first coordinate pair. It is assumed that the last coordinate should "connect" to the first coordinate pair.

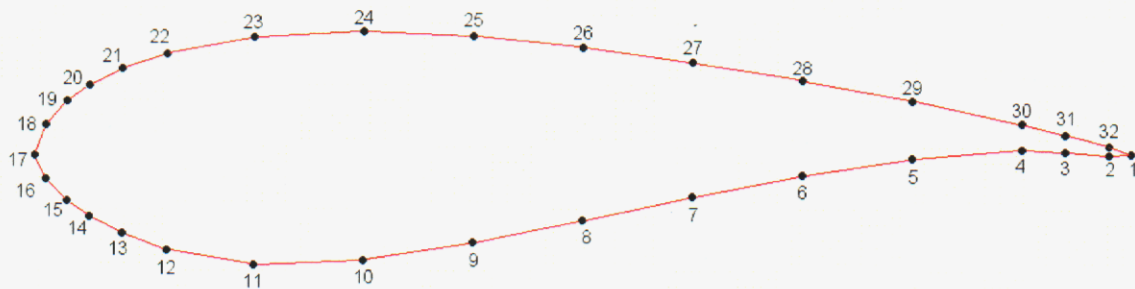

Figure 4.3 Sample airfoil profile with the clockwise coordinate numbering system.

The number of coordinate pairs in the file is important. A NuMAD model uses airfoil definitions with the same number of coordinate pairs. Thus in some cases it might be preferable to define the same airfoil with a few different numbers of coordinate pairs.

The airfoil definitions comprising the master airfoils database may be found in *NuMAD/Ncore/airfoils*. Again, these files are simple text files and may be modified with the user's favorite text editor (Notepad, Microsoft Word, vi, etc.). New airfoil definitions may be created with a text editor.

A typical airfoil profile definition is shown in Figure 4.4. At the beginning of the files is a reference block. The reference is delimited by the tags `<reference>` and `</reference>`. The user may place a reference or general note about the airfoil between the tags and this reference will be displayed in the window title bar when the airfoil is displayed. A reference is not required though the tags should be present, i.e., `<reference></reference>`.

The actual coordinate pairs are placed between the `<coords>` and `</coords>` tags. The first coordinate pair, 1 0, signifies the tail of the profile and the subsequent coordinate pairs define the airfoil in a clockwise direction. The final coordinate pair, 0.98002 0.00788, does not duplicate the first pair.

NuMAD reads the Airfoils Database when it is first launched. For this reason, additions or modifications to the Airfoils Database will not take effect until NuMAD is next launched.

```

<reference>
ref. NREL, Jim Tangler
</reference>
<coords>
1 0
0.980001 -0.00119
0.94001 0.00237
0.900001 0.0046
0.79998 -0.00401
0.69998 -0.01934
0.600001 -0.0388
0.500001 -0.06013
0.40002 -0.08066
0.30001 -0.09655
0.19998 -0.10069
0.11997 -0.08707
0.07998 -0.07231
0.05003 -0.05678
0.03001 -0.04304
0.00999 -0.02355
0.00007 -0.002
0.00994 0.02596
0.02998 0.04726
0.04988 0.06134
0.07995 0.07648
0.11991 0.09029
0.19998 0.10545
0.300001 0.11057
0.40001 0.1065
0.50001 0.0966
0.60001 0.08291
0.70001 0.06667
0.80001 0.04853
0.90003 0.02772
0.94006 0.01793
0.98002 0.00788|
</coords>

```

Figure 4.4 Sample airfoil profile definition file.

4.3 Global versus Local Airfoil Profiles Database

When a blade model is created and saved within NuMAD, the names of the airfoil profiles associated with each station in the model are saved to disk. When this model is later opened, the names of the airfoil profiles are used along with the master airfoil profiles database to reconstruct the blade model.

If an airfoil profile used by a saved NuMAD blade model is deleted from the master airfoil profiles database, the NuMAD blade model may no longer be retrieved by utilizing just the master airfoil profiles database. For this reason, when a NuMAD blade model is saved, copies of the airfoils used by the model are saved to the local jobname directory in a subdirectory named *airfoils* as shown in Figure 4.2. In this case the jobname is BladeXanalysis3 so the directory storing the blade model's data has that name. Storing a local copy of the airfoil profile data ensures that the model can always be retrieved, regardless of how the master airfoil profiles database may change.

As an example, a NuMAD blade model with a jobname of BladeY was created. This model used the airfoil profile definition S808.32 as well as other airfoils. This model was saved and NuMAD exited. At a later time, the file defining S808.32 was deleted from the master airfoil profiles database. At a still later time, NuMAD was launched and the user attempted to open the BladeY model. The warning dialog box shown in Figure 4.5 was presented to the user. This dialog box informs that the S808.32 profile is no longer part of the master airfoil profiles database and that it may be added back the master database or the local database may be used. If the user responds "Yes," the file defining S808.32 will be copied from the local database, *BladeY/airfoils/S808.32*, to the global database, *NuMAD/Ncore/airfoils/S808.32*. The blade model will then be opened as if S808.32 had never been deleted from the global database. If the user responds "No" to the dialog box, NuMAD will use the local airfoil profiles database for the remainder of the NuMAD session. It is generally recommended to use the former approach in which the missing airfoil is added back to the global airfoil profiles database.

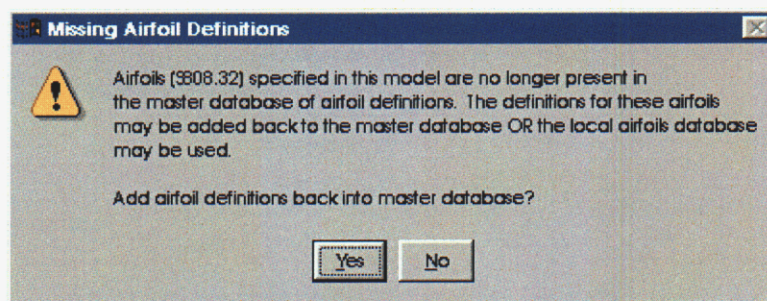

Figure 4.5 Dialog box indicating that an airfoil present in the selected model is no longer present in the master airfoils database.

¹ <http://www.xmlscript.org/docs/Tutorial.1.1.html>

CHAPTER 5 **Materials Database**

NuMAD uses a database of material properties so that this information need not be redefined with each new model. The material definitions are simple text files in an XML format. Work is ongoing to determine properties for an increasing number of materials to expand the database.

5.1 Location of Master Materials Database

The master materials database is located within the Ncore subdirectory of the root NuMAD directory. The database is comprised of five files; *ISOsi.xml*, *ORTHOsi.xml*, *COMPsi.xml*, *fibers.xml*, and *matrices.xml*. Though these files could be modified with a text editor, facilities for modifying the materials database have been included in NuMAD to reduce the chance of file corruption.

5.2 Accessing the Master Materials Database

Unlike the airfoils database, the master materials database is intended to be extended and modified through NuMAD. The master materials database is accessed through the “Materials” button on the main NuMAD menubar (Figure 5.1). Once the “Materials” button has been selected, the master materials database windows (Figure 5.2 and Figure 5.3) are displayed. These windows contain listboxes of materials, fibers, and matrices, as well as buttons to add, modify, or delete material definitions.

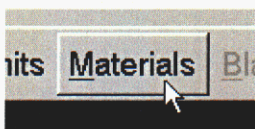
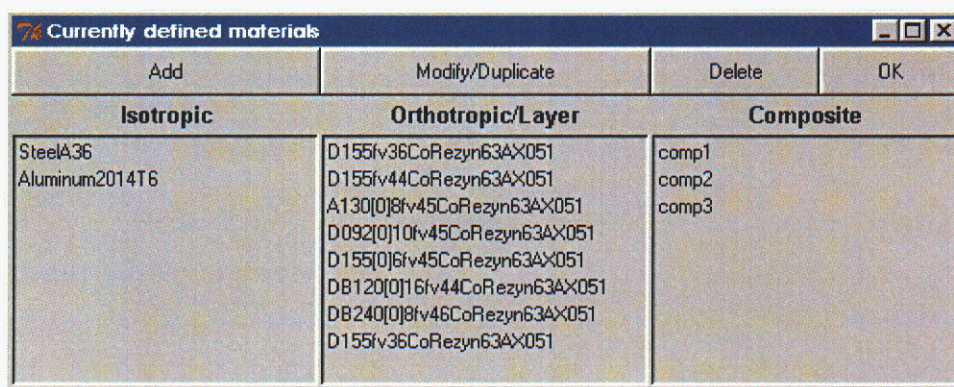

Figure 5.1 Materials button on main NuMAD menubar.



| Currently defined materials | | | OK |
|-----------------------------|------------------------------|-----------|----|
| Add | Modify/Duplicate | Delete | OK |
| Isotropic | Orthotropic/Layer | Composite | |
| SteelA36 | D155fv36CoRezvn63A×051 | comp1 | |
| Aluminum2014T6 | D155fv44CoRezvn63A×051 | comp2 | |
| | A130[0]8fv45CoRezvn63A×051 | comp3 | |
| | D092[0]10fv45CoRezvn63A×051 | | |
| | D155[0]6fv45CoRezvn63A×051 | | |
| | DB120[0]16fv44CoRezvn63A×051 | | |
| | DB240[0]8fv46CoRezvn63A×051 | | |
| | D155fv36CoRezvn63A×051 | | |

Figure 5.2 Master materials database window for isotropic, orthotropic, and composite materials.

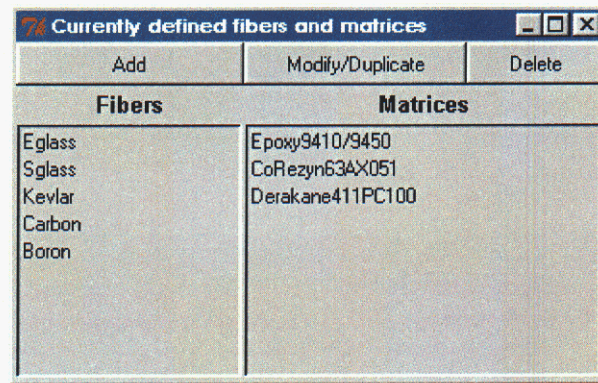

Figure 5.3 Master materials database window for fibers and matrix materials.

As the cursor passes over any material, fiber, or matrix name in any of the listboxes, a window is posted which displays the corresponding properties. These property display windows are posted below the listbox from which the material, fiber, or matrix name was indicated. Figure 5.4 shows a property display window for the laminate D155fv36CoRezyn63AX051 from the Orthotropic/Layer listbox. Within ANSYS®, a layer used to define a composite laminate material is just an orthotropic material. Thus the materials from this listbox are orthotropic materials which may be used to construct a composite laminate material definition.

The data displayed in the material properties display window will be in the currently selected system of units. The parameters E_x , E_y , and E_z refer to Young's modulus in the three orthogonal directions and G_{xy} , G_{yz} , and G_{xz} refer to the Shear moduli. The major Poisson's ratios in the three directions are assigned to the parameters ν_{XY} , ν_{YZ} , and ν_{XZ} and the values are unitless. For each material in the database, the user may enter a reference or note. For the material displayed in Figure 5.4, the reference names a source for the first nine parameters and indicates the method used to determine the final parameter, mass density.

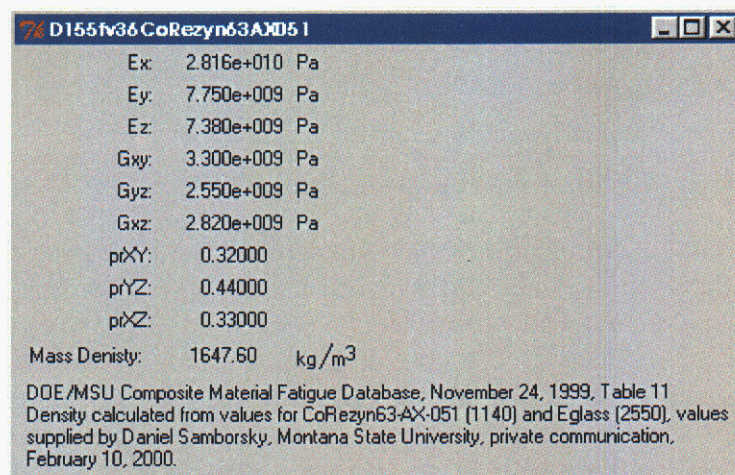

Figure 5.4 Material properties display window for D155fv36CoRezyn63AX051.

An example material property display window for a composite is shown in Figure 5.5. It lists the orthotropic materials comprising the stack and the thicknesses and fiber orientations for each layer. Figure 5.6 shows a material property display window for a matrix material. As discussed later, approximate orthotropic properties may be obtained by specifying a fiber, fiber content, and matrix.

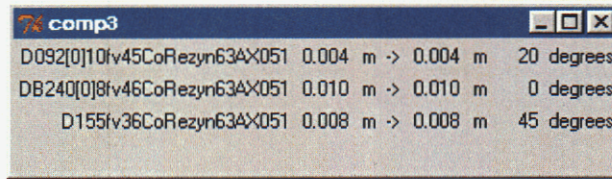

Figure 5.5 Composite laminate stack for comp3 which contains three layers of uniform thickness.

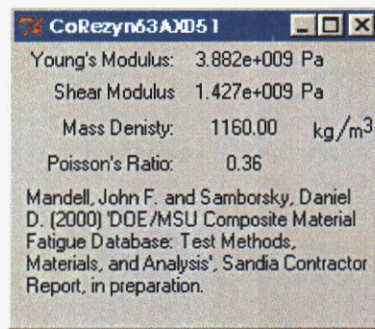

Figure 5.6 Material properties display window for CoRezyn63AX051.

5.3 Adding a New Material Definition

A material may be added to the master materials database by selecting the “Add” button from the “Currently defined materials” window. This action posts a menu which allows the user to specify the type of new material to be defined; isotropic, orthotropic, or composite (Figure 5.7).

5.3.1 Isotropic Material

Once the “Isotropic” entry has been selected from the menu shown in Figure 5.7, an interactive input window appears so that the user may enter the material properties directly (Figure 5.8). The material name should not match the name of any existing material but is otherwise arbitrary. This is the name that will appear in the Isotropic listbox. A Poisson's ratio greater than 0.5 is not allowed. The material properties are dynamically displayed in alternate systems of units as well as the current unit system. An inactive but selected checkbox labeled “new material” is present. This may be ignored when adding a new material, it will be discussed later. When the parameters have been entered and the “OK” button selected, the new material name is added to the isotropic listbox.

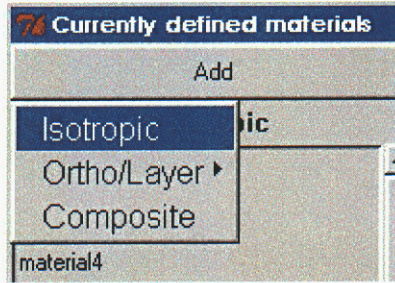

Figure 5.7 Add Material menu, Isotropic selected.

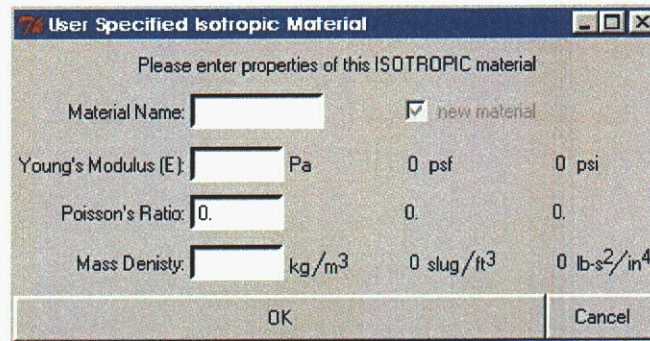

Figure 5.8 Dialog box used to define a new isotropic material. The values are input in the current system of units and displayed in two additional systems.

5.3.2 Orthotropic Material

When adding a new orthotropic material, there are two input methods from which to choose. The first method is direct definition which is similar to the method used for isotropic materials. This method is preferred because it requires test data. As an alternative, approximate material properties may be obtained by selecting a fiber, fiber volume, and matrix material from the “Currently defined fibers and matrices” window.

5.3.2.1 Direct Definition - Test Data

To directly define a new orthotropic material, select the “Add” button from the “Currently defined materials” window. Then choose “Ortho/Layer” from the menu and select “Direct Definition” from the submenu (Figure 5.9). This action will post the large input window shown in Figure 5.10. Once all of the parameter values have been entered and the “OK” button selected, the new material will be added to the Orthotropic/Layer listbox.

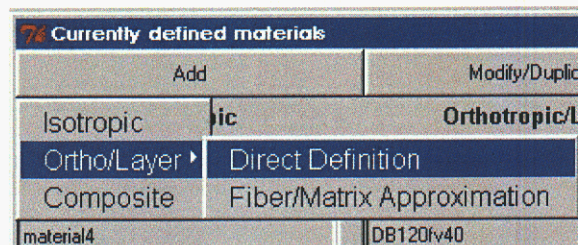

Figure 5.9 Add Material Menu, Direct Definition Orthotropic Material (Layer) selected.

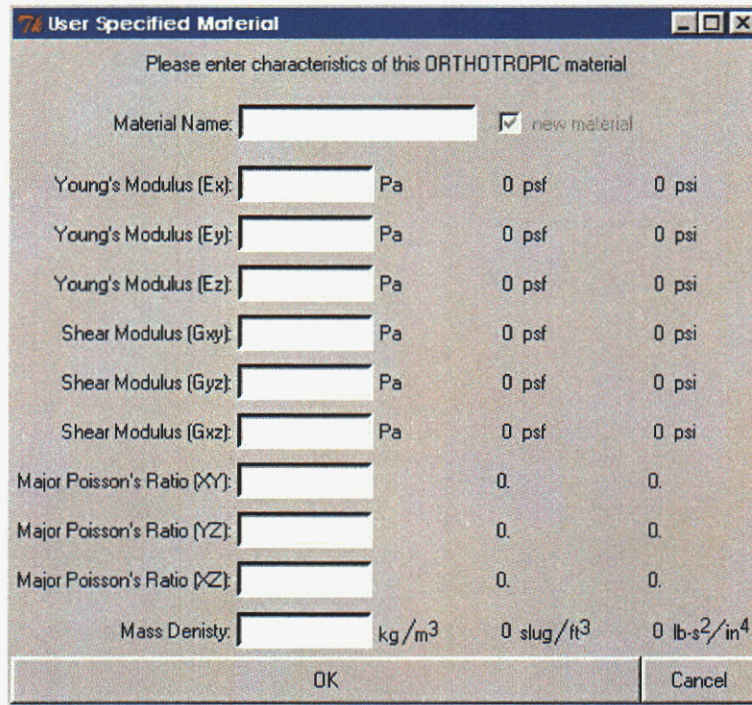

Figure 5.10 Dialog box used for direct definition of a new orthotropic material. The values are input in the current system of units and displayed in two additional systems.

5.3.2.2 Fiber/Matrix Approximation (Rule of Mixtures)

If test data is not available, approximate material property values may be obtained from the fiber and matrix material properties. To begin this process, choose “Fiber/Matrix Approximation” as shown in Figure 5.11. This action will post a window titled “Create a new layer” as shown in Figure 5.12. Next, the user enters a layer name that will appear in the Orthotropic/Layer listbox. A fiber and a matrix are chosen by selecting from the “Currently defined fibers and matrices” window. When a fiber name or matrix name is selected, that name appears in the “Create a new layer” window. A value for fiber content should be supplied as a percentage as well as a Halpin-Tsai fiber reinforcement constant.

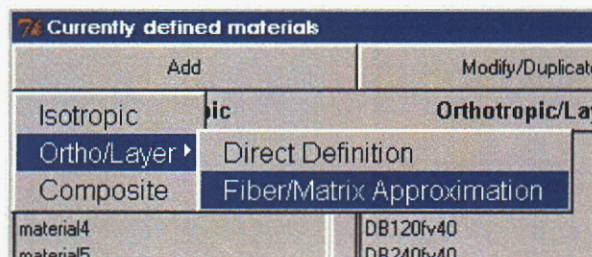

Figure 5.11 Add Material Menu, Fiber/Matrix approximation for Orthotropic Material (Layer) selected.

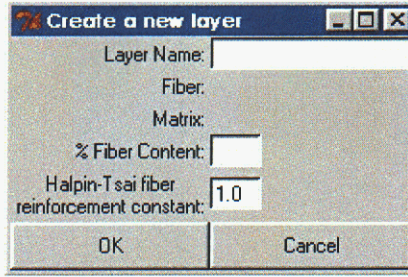

Figure 5.12 Dialog box used for fiber/matrix approximation of a new orthotropic material. The Halpin-Tsai equations are used to determine the orthotropic material properties.

The material properties actually added to the database are obtained using the Halpin-Tsai equations¹ shown below.

$$E_1 \cong E_f V_f + E_m V_m \quad (1)$$

$$\nu_{12} = \nu_f V_f + \nu_m V_m \quad (2)$$

$$\frac{M}{M_m} = \frac{1 + \xi \eta V_f}{1 - \eta V_f} \quad (3)$$

where

$$\eta = \frac{(M_f / M_m) - 1}{(M_f / M_m) + \xi} \quad (4)$$

M = composite modulus E_2 , G_{12} , or ν_{23}

M_f = corresponding fiber modulus E_f , G_f , or ν_f

M_m = corresponding matrix modulus E_m , G_m , or ν_m

The parameter ξ is a measure of the fiber reinforcement of the composite that depends on the fiber geometry, packing geometry, and loading conditions [3] and may be specified by the user or assigned default values. The value of ξ is bound between $\xi=0$ and $\xi=\infty$. The case of $\xi=0$ corresponds to the matrix and fiber in series while $\xi=\infty$ represents the matrix and fiber in parallel.

5.3.3 Composite Laminate Material

A new composite laminate material may be defined by selecting the “Composite” entry as shown in Figure 5.13. This action will post the “Composite Material” window shown in Figure 5.14. Again a name must be entered, this name will appear in the Composite listbox.

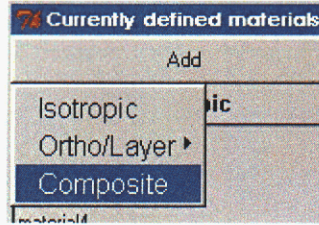

Figure 5.13 Add Material menu, Composite laminate selected

5.3.3.1 Symmetry Type

The “Composite Material” input window also has three radio buttons labeled “Asymmetric,” “Even Symmetry,” and “Odd Symmetry.” These designations refer to the type of material definition to be performed within in ANSYS®. An even symmetric stack refers to a symmetric stack with an even number of total layers. An odd symmetric stack is symmetric with an odd number of total layers so that the middle layer is not reflected. An asymmetric stack has no symmetry.

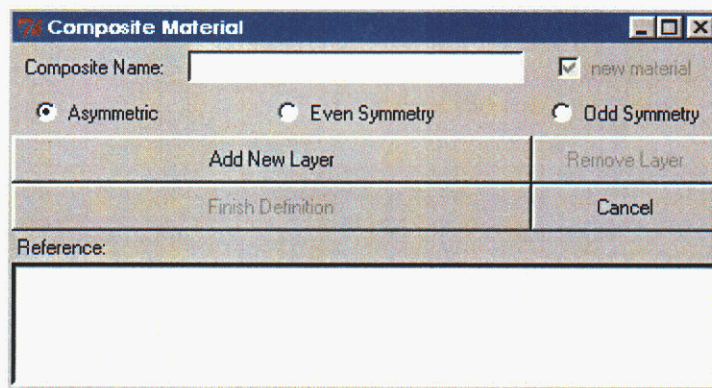

Figure 5.14 Dialog box used to begin definition of a new composite laminate material.

Next, layers are added to create the composite material definition. When the “Add New Layer” button is selected from the “Composite Material” window, the “Add Layer” input window shown in Figure 5.15 is posted. The material for the layer may be selected from the orthotropic/layer listbox. Once selected, the layer name will appear in the “Add Layer” input window.

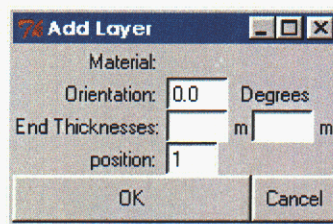

Figure 5.15 Input window used to add a layer to a composite material definition.

5.3.3.2 Fiber Orientation

The sense of the fiber orientations is shown in Figure 5.16. Unfortunately, this definition contradicts the standard interpretation of fiber orientation for a wind turbine blade. While zero-degree fibers are generally meant to align with the blade axis, zero-degree fibers in NuMAD run perpendicular to the blade axis. The reason for this strange definition stems from ANSYS® and finite element analysis in general. Each element in the finite element model has its own coordinate system. Figure 5.17 shows a schematic of the SHELL99 element used by ANSYS®. The element x-axis starts at the “I” node and is oriented towards the “J” node. The “I” node is simply the ANSYS® designation for the first node defining the element and the “J” node is the second node defining the element. The element z-axis is defined to be perpendicular to the plane defined by the I, J, and K nodes. The y-axis is then defined to be perpendicular to both the x-axis and z-axis and to complete a right-handed orthogonal system.

While the element coordinate system is easy to manage for rectangular, planar elements; this is rarely the situation with a model of a real object. When modeling a wind turbine blade, the shell elements are required to have irregular shapes and curvature. For the shell elements used to model wind turbine blades with NuMAD, the only information known about the elements is that the I and J nodes will lie on the airfoil profile and the K node will lie on the blade tip side of the airfoil profile. This results in the orientation angle definition shown in Figure 5.16.

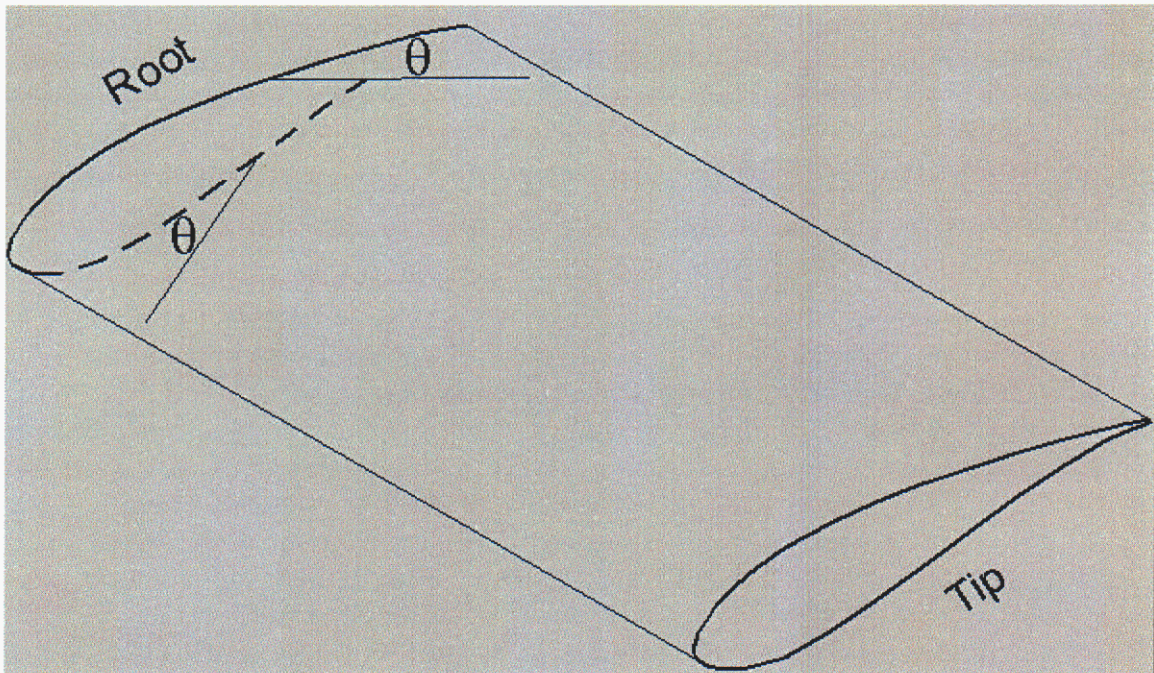

Figure 5.16 Schematic indicating the sense of the layer orientations.

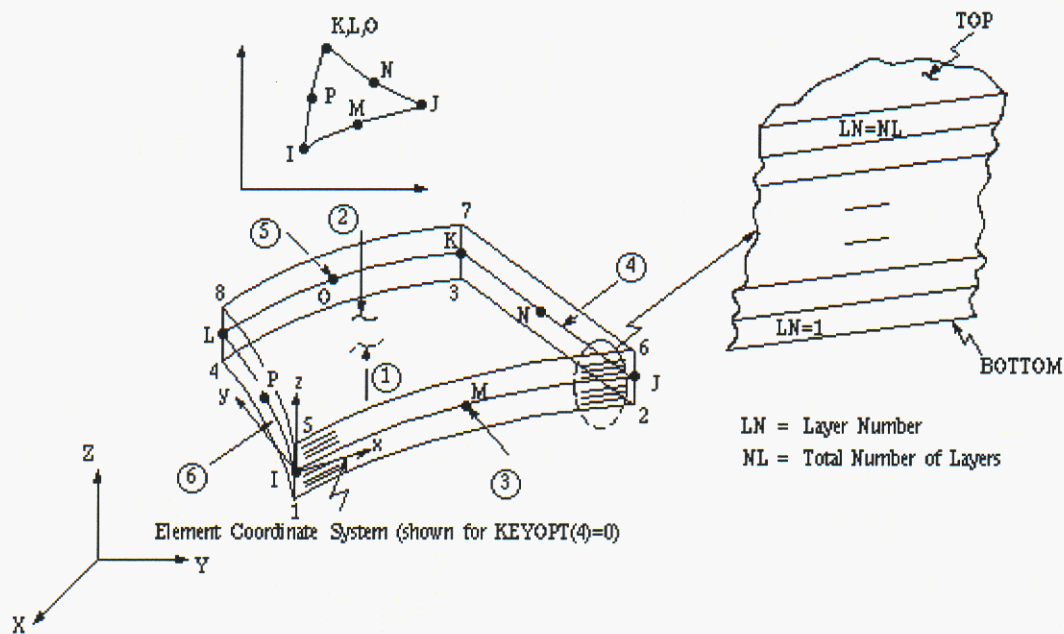

Figure 5.17 Schematic of ANSYS element SHELL99 displaying the element coordinate system².

The idea of adding a 90 degree rotation to all composite material layer orientations was considered and rejected. Such an approach would theoretically allow zero degree fiber orientations within NuMAD to be parallel to the blade axis. This approach was not implemented due to the fact that models created with NuMAD may be later modified or extended from within ANSYS®. It would be confusing to define a material layer to have a 20 degree fiber orientation in NuMAD and later see the same layer for the same material have a 70 degree fiber orientation in ANSYS®.

5.3.3.3 Adding Layers

Once the orientation and end thicknesses of the layer have been defined in the “Add Layer” window (Figure 5.15), the user selects “OK” and a representation of the stack is displayed. Figure 5.18 shows the laminate schedule window after one layer has been defined. At the left, the layer number, thickness, and fiber orientation are listed. The name of the layer material is displayed within the schematic and the fiber orientation is represented on the upper surface of the layer. At this point the “Composite Material” window (Figure 5.14) will be reposted but now that at least one layer exists, the “Remove Layer” and “Finish Definition” buttons are active. Figure 5.19 shows the stack after a second layer has been added. The total stack thickness is given in the lower left corner of the laminate schedule window. When this second layer was added, the user had a choice of whether to place the new layer above or below the first layer. This decision is accomplished through the “position” entry in the “Add Layer” window (Figure 5.15). The new layer is added at the position indicated by the value in the entry box. By default, NuMAD fills in the correct value which will place the new layer on top of the stack (interior). The user, however, may change this number to any acceptable value.

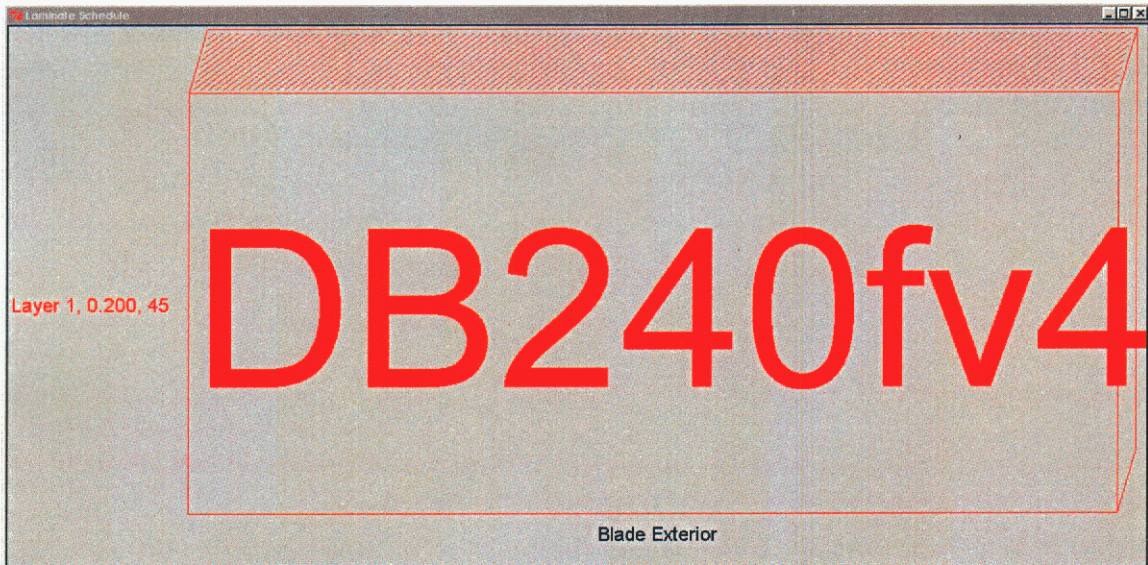

Figure 5.18 Schematic display of new composite laminate material definition after only one layer has been defined.



Figure 5.19 Schematic display of composite laminate material definition after two layers have been defined.

At any time that the “Composite Material” window is posted, the symmetry type of the laminate may be changed. Thus, after the first two layers in the current example have been defined, the symmetry type may be changed from asymmetric to even symmetric as shown in Figure 5.20. This will immediately cause the laminate schedule window to update and represent the stack as shown in Figure 5.21. The symmetry layers are now displayed and the total thickness has doubled. Layer numbers, thicknesses, etc. are not listed for the symmetry layers to indicate that these layers were not explicitly defined. Changing the symmetry type to odd symmetric produces the laminate schedule shown in

Figure 5.22. The final explicitly defined layer is not reflected and the stack thickness again changes.

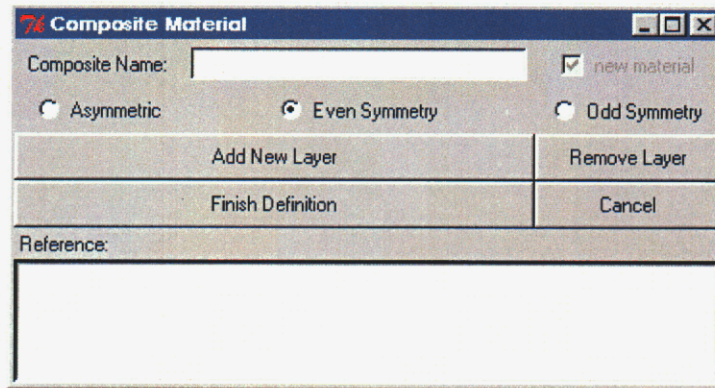

Figure 5.20 Input window used in the definition of a composite laminate material. The symmetry setting is “Even Symmetry.”

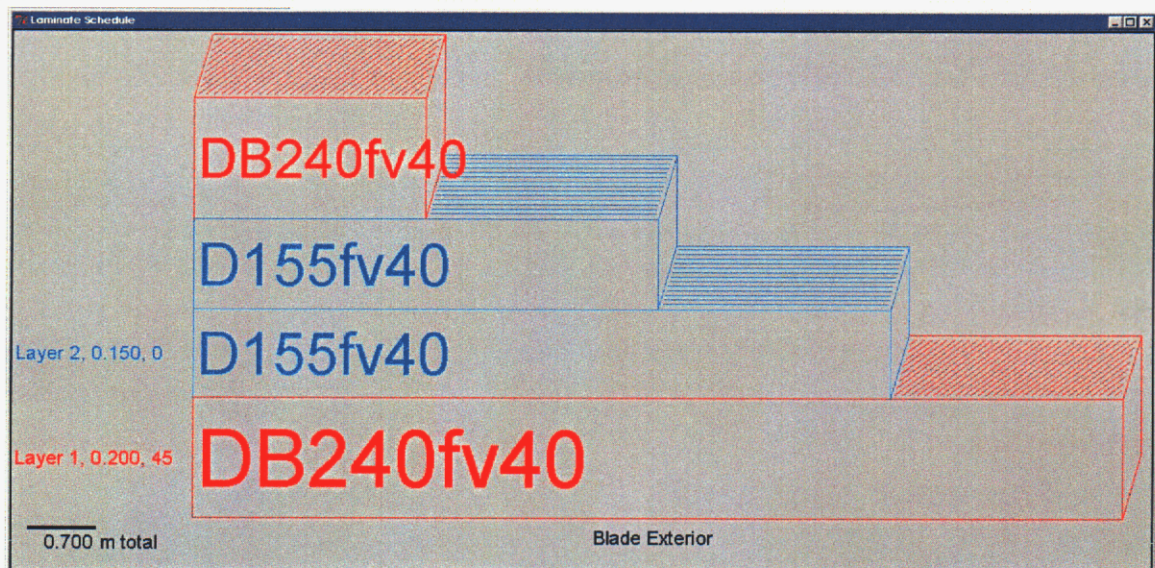

Figure 5.21 Schematic display of composite laminate material definition after two layers have been defined for an even symmetric stack.



Figure 5.22 Schematic display of composite laminate material definition after two layers have been defined for an odd symmetric stack.

By repeatedly adding layers, the desired composite material may be defined. Before the definition of the composite material is finished, the user may add a reference or note in the reference box at the bottom of the “Composite Material” window (Figure 5.20). This reference will be displayed when the name of the composite material is selected from the Composite listbox. Once the user selects “Finish Definition” from the “Composite Material” window (Figure 5.20), the new material is added to the master (global) materials database.

5.4 Deleting a Material Definition

To delete a material definition from the master materials database, the user simply selects the material name and the “Delete” button. As discussed below, the deletion of a layer definition may result in automatic deletion of a composite material.

5.4.1 Composites and Unused Isotropics and Layers

To delete a composite material definition, simply select the composite material name from the composite materials listbox and select the “Delete” button from the “Currently defined materials” window. Figure 5.23 shows the “comp3” material selected and the “Delete” button being selected. Such action will produce the confirmation dialog box shown in Figure 5.24. This dialog box merely prevents an accidental deletion of a material definition. If no material name of any kind were selected, the error dialog box shown in Figure 5.25 would be presented. This reminds the user that a material name must be selected before a material definition deletion may be performed.

“Unused” isotropics and “unused” layers refer to material definitions which are not currently referenced by any of the composite material definitions. To delete these materials, the process is exactly as just described in the previous paragraph.

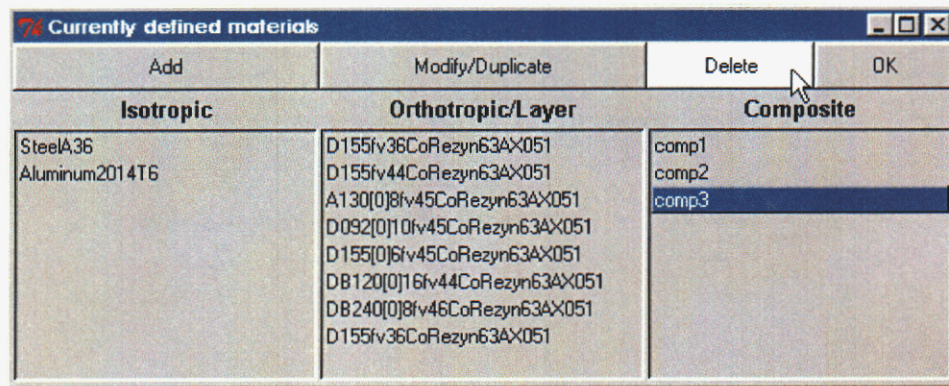

Figure 5.23 Deleting the “comp3” material from the master materials database.

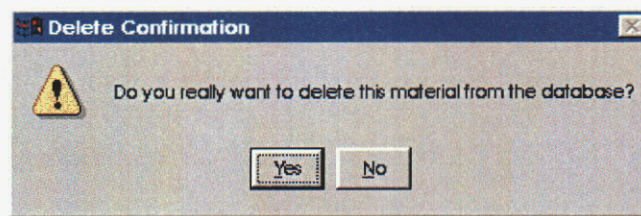

Figure 5.24 Confirmation dialog box to prevent accidental deletion of material definition.

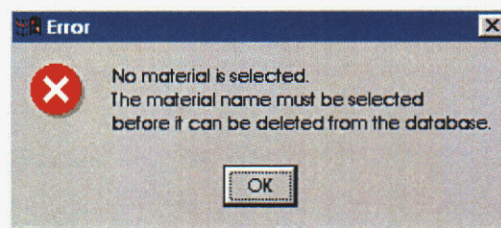

Figure 5.25 Error dialog box to indicate that no material is selected.

5.4.2 Isotropics and Layers Used in Composite Definitions

An isotropic or layer used in the definition of a composite material may be deleted but the NuMAD user must exercise more caution. When the user attempts to delete a layer, for example, that is referenced by one or more composite material definitions, a warning dialog box such as the one shown in Figure 5.26 will be displayed. In this case the user selected the Orthotropic/Layer material “D155fv40” and the “Delete” button. NuMAD then did a search of the currently defined composite materials and found “D155fv40” to be present in four of them. Due to the fact that a composite material may not define a layer with a reference to an undefined material, all composite materials referencing “D155fv40” must be deleted as well. This is reflected in the dialog box shown in Figure 5.26. It indicates that the material “D155fv40” is present in the composite material definitions “comp1,” “comp98,” “compThin1,” and “compThin2.” If the user selects “OK” from this dialog box, the four composite materials definitions will be deleted along with the selected layer material, “D155fv40.”

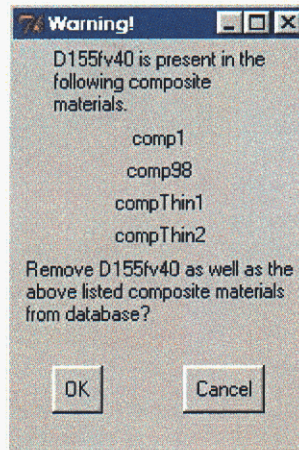

Figure 5.26 Dialog box warning that the deletion of a particular orthotropic material (D155fv40) from the database will result in the deletion of four composite materials (comp1, comp98, compThin1, compThin2) from the database.

5.5 Modifying a Material Definition

To modify or duplicate a material definition, select the desired material and selected the “Modify/Duplicate” button from the “Currently defined materials” window as shown in Figure 5.27. This action will produce an input window as indicated in Figure 5.28. At this point the user may modify any of the parameters defining the material, similar to the process described to add a new material in section 5.3. One major difference between the input windows to add a material versus the input windows to modify/duplicate a material is the state of the “new material” checkbox shown in Figure 5.28. When accessing a material through the “Modify/Duplicate” button, the “new material” checkbox is active. This means that the user may leave the box unchecked to simply modify the existing material definition or the user may check this box to indicate a new and completely different material. This is a very useful approach for creating a number of different but similar material definitions. The user may simply duplicate a base material definition by selecting the “new material” checkbox and changing the material name.

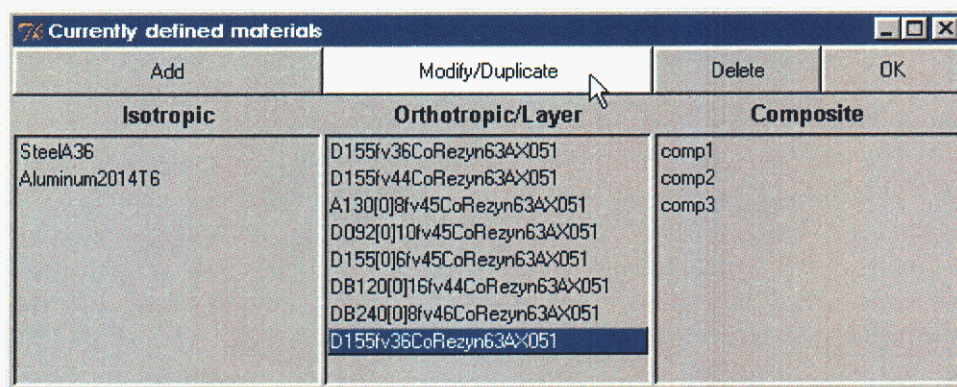

Figure 5.27 Process to modify or duplicate the definition of the “D155fv36CoRezynn63AX051” material.

User Specified Material

Please enter characteristics of this ORTHOTROPIC material

Material Name: new material

| | | | | | | |
|-----------------------------|---|-------------------|---------------|----------------------|-------------------|------------------------------------|
| Young's Modulus (Ex): | <input type="text" value="2.816e+010"/> | Pa | 588132864.0 | psf | 4084270.08 | psi |
| Young's Modulus (Ey): | <input type="text" value="7.750e+009"/> | Pa | 161861850.0 | psf | 1124044.5 | psi |
| Young's Modulus (Ez): | <input type="text" value="7.380e+009"/> | Pa | 154134252.0 | psf | 1070380.44 | psi |
| Shear Modulus (Gxy): | <input type="text" value="3.300e+009"/> | Pa | 68921820.0 | psf | 478625.4 | psi |
| Shear Modulus (Gyz): | <input type="text" value="2.550e+009"/> | Pa | 53257770.0 | psf | 369846.9 | psi |
| Shear Modulus (Gxz): | <input type="text" value="2.820e+009"/> | Pa | 58896828.0 | psf | 409007.16 | psi |
| Major Poisson's Ratio (XY): | <input type="text" value="0.32000"/> | | 0.32000 | | 0.32000 | |
| Major Poisson's Ratio (YZ): | <input type="text" value="0.44000"/> | | 0.44000 | | 0.44000 | |
| Major Poisson's Ratio (XZ): | <input type="text" value="0.33000"/> | | 0.33000 | | 0.33000 | |
| Mass Density: | <input type="text" value="1647.60"/> | kg/m ³ | 3.19687065204 | slug/ft ³ | 0.000154169115064 | lb-s ² /in ⁴ |

Reference: DOE/MSU Composite Material Fatigue Database, November 24, 1999, Table 11
Density calculated from values for CoRezyn63-AX-051 (1140) and Eglass (2550),
values supplied by Daniel Samborsky, Montana State University, private
communication, February 10, 2000.

OK Cancel

Figure 5.28 Input window to modify or duplicate the definition of the material “D155fv36CoRezyn63AX051”.

5.6 Local Materials Database

Similar in function to the local airfoil profiles database, a local materials database is created whenever a job is saved. This local database contains the definition of each material used in the model and is comprised of five files in the jobname directory: *COMPsi.xml*, *ORTHOsi.xml*, *ISOsi.xml*, *fibers.xml*, and *matrices.xml*. This data may be useful if the model uses a material which is later removed from the master (global) material database.

As an example, a NuMAD blade model with a jobname of BladeZ was created. This model used the composite material definition named comp1 as well as other composite materials. This model was saved and NuMAD exited. At a later time, comp1 was deleted from the master (global) materials database. At a still later time, NuMAD was launched and the user attempted to open the BladeZ model. The warning dialog box shown in Figure 5.29 was presented to the user. This dialog box informs that the comp1 material is no longer part of the master (global) materials database and that it may be added back the master (global) materials database or the local materials database may be used. If the user responds “Yes,” the comp1 definition will be copied from the local database, *BladeZ/COMPsi.xml*, to the master (global) materials database, *NuMAD/Ncore/COMPsi.xml*. The blade model will then be opened as if the definition of

comp1 had never been deleted from the master (global) materials database. If the user responds “No” to the dialog box, NuMAD will use the local materials database for the remainder of the NuMAD session. It is generally recommended to use the former approach in which the missing material definition is added back to the master (global) materials database.

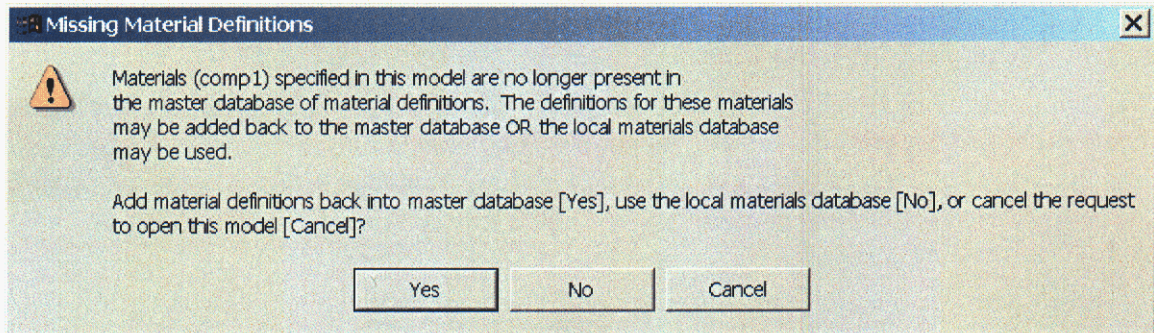

Figure 5.29 Warning dialog box indicating that a composite material (comp1) defined in the model is no longer present in the master (global) materials database.

¹ Jones, R.M., Mechanics of Composite Materials, 1975.

² ANSYS 5.7 Documentation, SHELL99, Figure 1

Once the user has defined the necessary airfoil profiles and materials for the desired model, the actual blade model definition may begin. This process includes the definition of the blade external geometry, internal shear webs, and materials.

6.1 Current Model

Though limited functionality is available as soon as NuMAD is launched, many of the features are only active after a blade model has been loaded into memory. A blade model may be loaded by either opening an existing NuMAD model or by creating a new model.

6.1.1 New Model

To begin a new model, choose "New Model" from the "File" menu as shown in Figure 6.1. This action will produce the "New Job Name (directory)" dialog window (Figure 6.2). The user then navigates to the desired directory and enters the new job name. NuMAD then creates a sub-directory with the specified name and all NuMAD data for the new blade model will be stored in that directory.

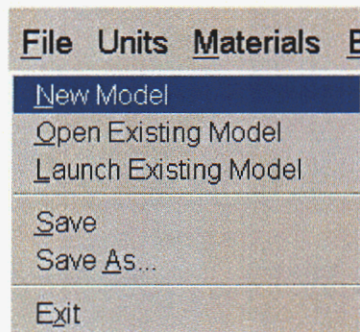

Figure 6.1 "New Model" entry selected from "File" menu.

Once specified, the full pathname to the directory should be displayed at the top of the NuMAD application window. This allows the NuMAD user to quickly verify the path for the current blade model before disk operations such as "Save" or "Save As."

6.1.2 Opening an Existing Model

Another option for setting the job name is to load an existing NuMAD model. Again the "File" menu is accessed though the "Open Existing Model" entry is now selected as in Figure 6.3. This action will produce the "Choose any file in the job directory" dialog window (Figure 6.4). At this point, the user should select any file within the desired directory. In Figure 6.4, the file *Sdata3.nmd* has been selected though any of the other files in the directory would also work. Selecting the subdirectories "airfoils" or "modal" would simply navigate the user into those directories and would not set the job name to the desired setting, "TestA." Once the appropriate job name (directory) has been specified, the full pathname to the directory should be displayed at the top of the NuMAD application window.

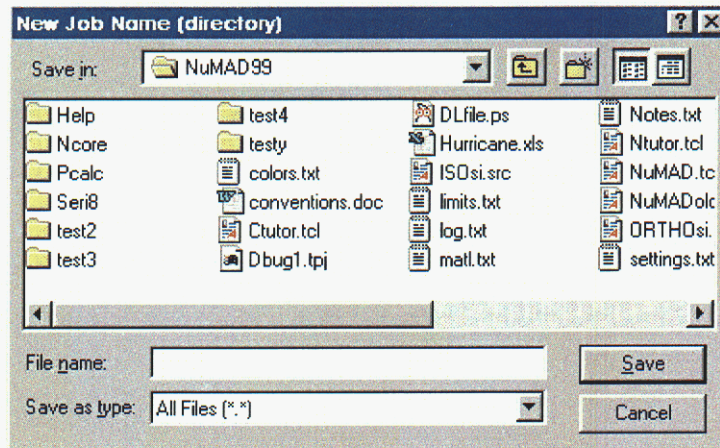

Figure 6.2 Dialog box for specifying a new job name. A directory (folder) with the job name is then created.

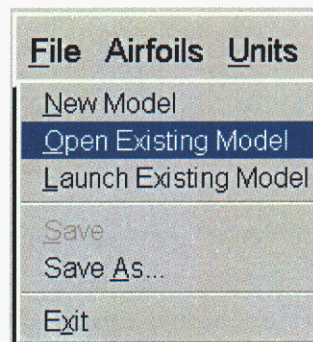

Figure 6.3 “Open Existing Model” entry selected from “File” menu

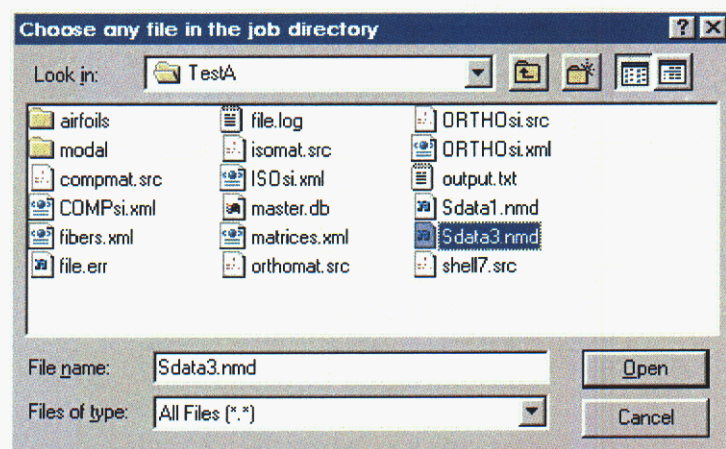

Figure 6.4 Dialog box for loading (opening) an existing NuMAD model. Any file may be chosen in the directory.

6.2 Define or Display Model

Once a job name has been specified, a blade geometry may be created in the case of a new model or the previously created geometry may be displayed in the case of an existing model.

6.2.1 New Blade Geometry

To create a blade geometry after a new job name has been specified, the “Define” entry should be selected from the “Blade” menu as shown in Figure 6.5. The deactivated state of the other entries in the menu, “Display/Modify” and “Scale,” indicates that a new blade model is being created. If a blade geometry was currently in memory, all entries in the menu would be active as discussed later in Figure 6.16. When defining a new blade model geometry, the user may choose to manually select each airfoil profile, chord length, etc. or to read the external blade shape from a series of files. The former approach is called manual skin geometry definition while the latter is automatic skin geometry definition.

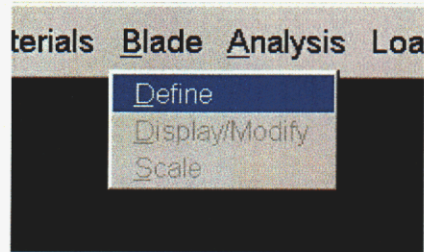

Figure 6.5 “Define” entry selected from “Blade” menu. The deactivated state of the other entries in the menu indicates that a new job name has been defined.

If a blade model is currently in memory, it may be erased and a new model begun by selecting “Define” from the “Blade” menu. All entries in the “Blade” menu would be active opposed to the “Blade” menu shown in Figure 6.5 which has two entries deactivated. Before erasing the existing model a warning dialog box (Figure 6.6) would be presented to the user.

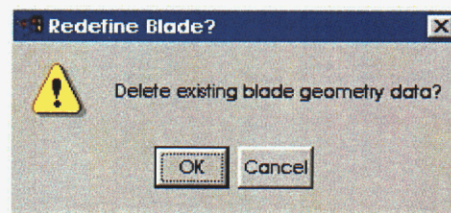

Figure 6.6 Dialog box to prevent accidental deletion of blade data.

6.2.1.1 Manual Skin Geometry Definition

After the NuMAD user selects “Define” from the menu shown in Figure 6.5, the user is presented with the dialog box used to select the method of external geometry input (Figure 6.7). At this point the user may specify the total blade length in the currently

selected system of units. A default blade length of 100 units is initialized. This total blade length value may also be modified after the blade schematic is displayed.

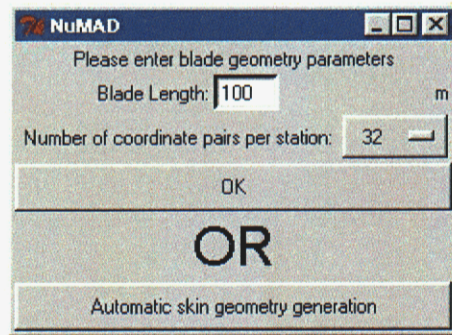

Figure 6.7 Dialog box to select the method of external geometry input.

An option menu allows the user to select the number of coordinate pairs per station to be used in the new model. NuMAD searches the master airfoil profiles database and determines the number of coordinate pairs defining each profile. An entry is inserted into the option menu for each unique number of coordinate pairs. The default value ("32" in Figure 6.7) corresponds to the number of coordinate pairs found in the first airfoil profile definition in the master airfoil profiles database. In Figure 6.8, the user is changing the number of coordinate pairs per station from the default value of 32 to 64. This instructs NuMAD to only present airfoil profiles defined by 64 coordinate pairs during later blade geometry modification.

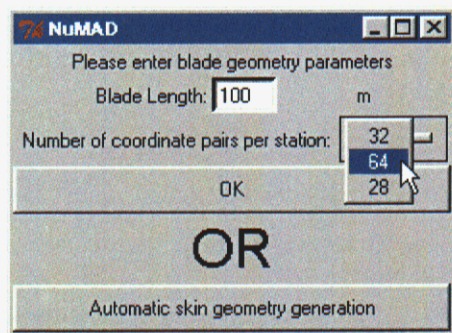

Figure 6.8 Dialog box to select the method of external geometry input. The option menu to select the number of coordinate pairs per station is active.

Once the user accepts the blade length and number of coordinate pairs selections ("OK" in Figure 6.8), the blade geometry modification windows are displayed. One of the blade geometry modification windows is the "Blade Schematic" window (shown in Figure 6.9). This window provides of simple schematic of the current geometry of the blade model. For a new model using manual external blade geometry definition, a simple two-station tube is created as indicated in Figure 6.9. The airfoil profile chosen for both stations is simply the first profile in the master airfoil profiles database. The default material chosen for the skin is the first composite material in the master materials database. From this starting point, the NuMAD user may then proceed to modify and add stations, materials, and shear webs.

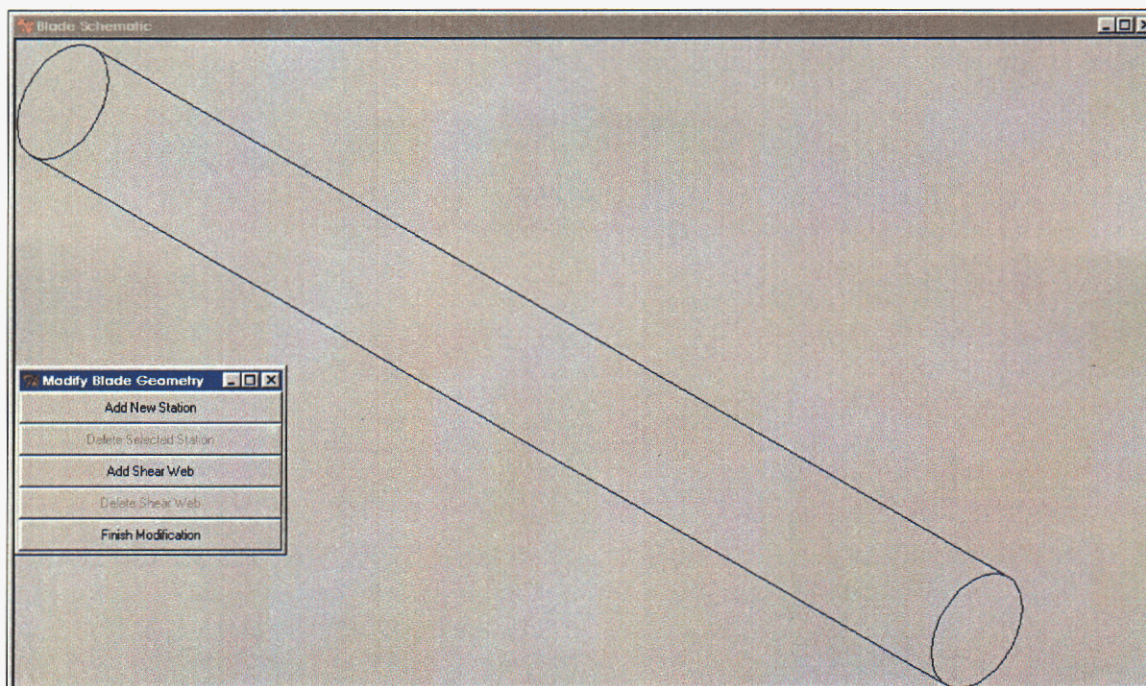

Figure 6.9 Initial “blade” created when a new model is being defined. The profiles used are the first profile in the master airfoil profiles database.

6.2.1.2 Automatic Skin Geometry Definition

An alternative to the manual skin geometry definition method is to choose a data set which contains the various stations defining the blade. In this case, the data should be in physical units (non-normalized) with all twist, chord length, etc. incorporated into the data. The blade data must be organized so that each station to be present in the model has its profile data stored in a unique file. All of the files corresponding to station profile data must reside within the same directory (folder). Additionally, the filenames for the station profiles must contain the Z-locations of the profiles where 0.0 is at the root.

To begin the process, select the "Automatic skin geometry generation" button from the external blade geometry dialog box as shown in Figure 6.10. This action produces the units verification dialog box shown in Figure 6.11. Though the model may be scaled at a subsequent time, it is easier to ensure that the appropriate system of units has been selected. A “No” response to the units verification dialog box causes the units selection menu to post and allow the user to immediately change the selected system of units.

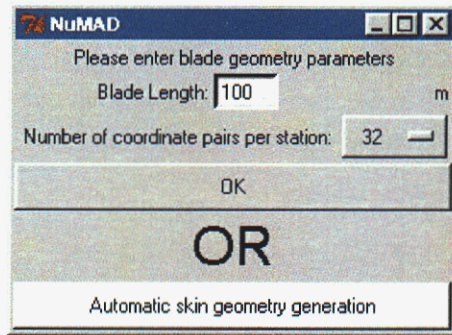

Figure 6.10 Dialog box to select the method of external geometry input, automatic external geometry generation in this case.

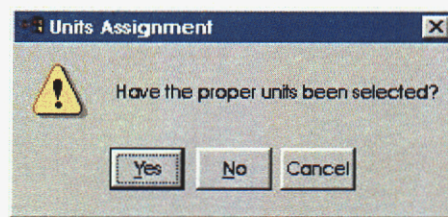

Figure 6.11 Dialog box to ensure desired units are selected before automatic external geometry generation begins.

After the user accepts the choice of units, a file selection dialog appears as shown in Figure 6.12. The user then navigates to the desired directory, opens the directory, and selects any file within that directory. In Figure 6.12, the file names contain the locations of the profiles in mm from the root. Thus the file Sta03100.37 contains the profile data for the station which is 3100 mm (3.1 m) from the root. Also in this example, the file names have the file extension "37" indicating that each file has 37 coordinate pairs.

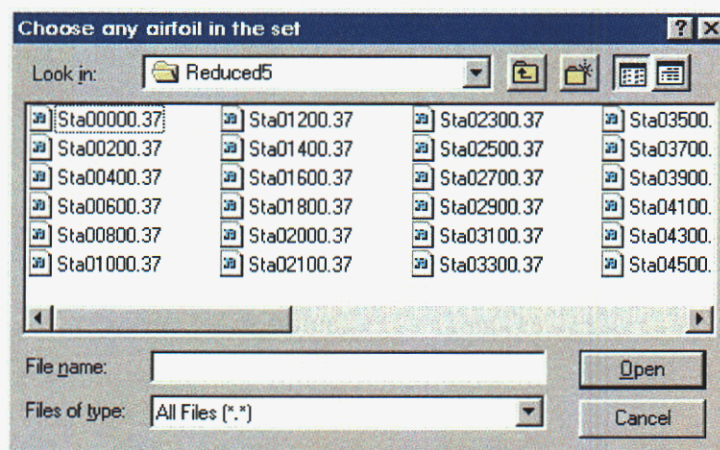

Figure 6.12 Dialog box to select data set for automatic external geometry generation.

For automatic blade skin generation, it is important that the file names have the location represented as 5 digits (no fewer, no more) in the fourth through eighth position in the

file name. The other positions may contain any valid character. Thus xyz21800.32, abc01050x.txt, and Sta29000.37 are all valid for automatic generation. The file names x1435008.txt and Mar151999.dat are valid though probably confusing. File names Station21500.32 and St3150.txt would be invalid.

Once a file within the correct directory has been selected, NuMAD will generate the blade and the user may make modifications just as if the blade had been defined manually.

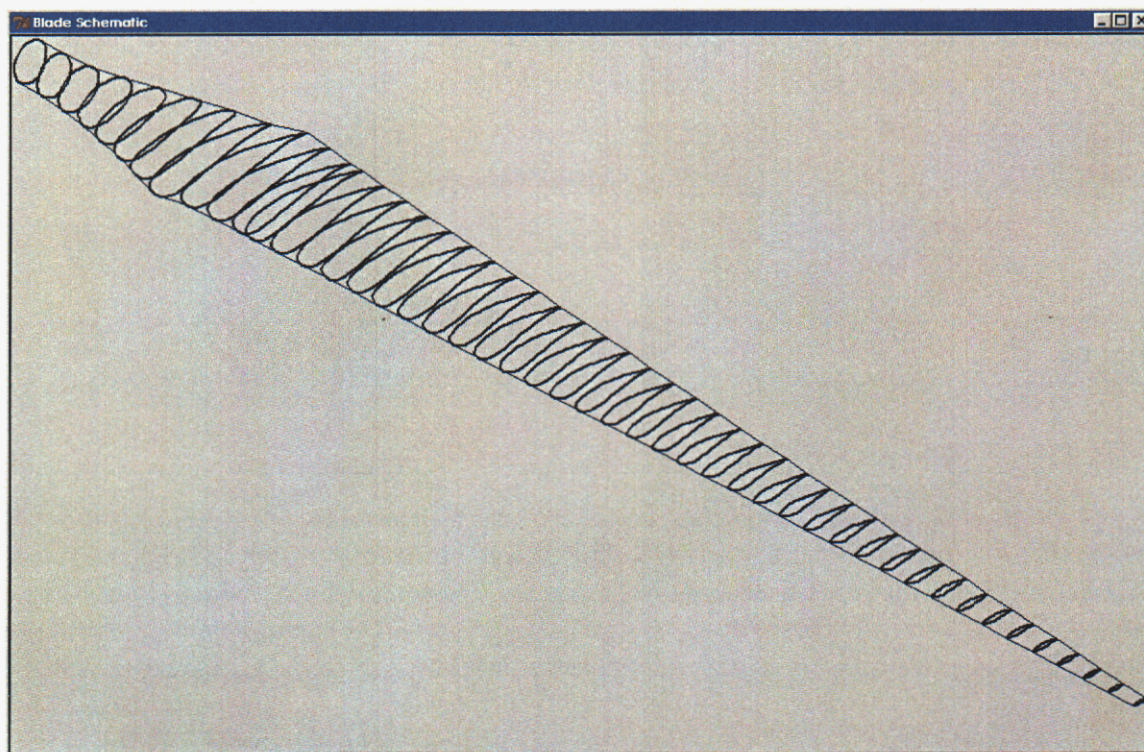

Figure 6.13 Schematic of blade model generated through automatic external geometry generation.

In some cases the existing blade geometry data may contain far more coordinate pairs than desired for use with NuMAD. This is often the case if it is desired to use aerodynamic data as input for the structural analysis. In such a case NuMAD can automatically reduce the number of coordinate pairs in the files describing the external blade geometry by removing some of the data. For instance, if every other coordinate pair is removed from a file, only half of the coordinate pairs remain. Obviously, some of the resolution describing the blade has been lost but this is often acceptable for a structural analysis.

To start this process, the user selects the "Reduce" entry from the "Airfoils" menu (Figure 6.14). The user is then prompted to indicate the path to the directory containing the original data. Once the path has been indicated, the input window shown in Figure 6.15 is displayed. An option menu allows the user to select reduction of the current profile descriptions to 1/2, 1/3, 1/4, 1/5 etc. the current size. Another option menu allows

the user to specify whether or not the new files created should use the number of coordinate pairs remaining as a file suffix. For the sample values seen in Figure 6.15, a file called *Sta00400.txt* containing 208 coordinate pairs would become a file called *Sta00400.52*. After the user selects “OK” from the “Specify Reduction” input window, a dialog box queries the user for a path and directory name for the new data files to be generated. It is this new directory of data that can then be later accessed for automatic skin geometry generation.

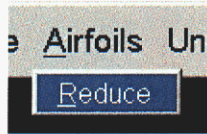

Figure 6.14 Menu used to reduce the number of coordinate pairs in files defining external blade geometry.

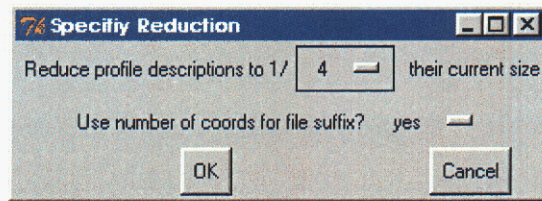

Figure 6.15 Input window to specify how to reduce number of coordinate pairs in files defining the external blade geometry.

6.2.2 Existing Blade Geometry

To display an existing model simply choose “Display/Modify” from the “Blade” menu as shown in Figure 6.16. As mentioned earlier, the “Display/Modify” entry will not be active unless a model has been loaded into memory. Once “Display/Modify” has been selected, the blade geometry modification windows are presented.

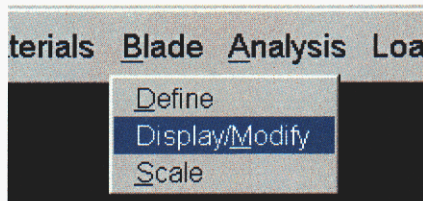

Figure 6.16 “Display/Modify” entry selected from “Blade” menu. The active state of the other entries in the menu indicates that a blade geometry is currently in memory.

6.3 Modify Blade Model

Most of the effort involved in defining a blade model occurs through the blade geometry modification windows. This is where NuMAD allows the user to add, remove, or modify

stations and shear webs. This is also where the user may assign materials defined previously to specific portions of the blade skin or to shear webs. Figure 6.17 shows the windows first presented for a new blade model. Near the top of the screen is a window titled “none selected” which is used to display airfoil profiles. Initially, no profile is selected and thus this window is empty. Directly below the airfoil profile display window is the “Blade Schematic” window which displays the current blade. To the left of the “Blade Schematic” window is the “Modify Blade Geometry” window. This window contains a column of buttons which allows the user to modify the blade geometry. The functionality accessed by this window is discussed in the following sections.

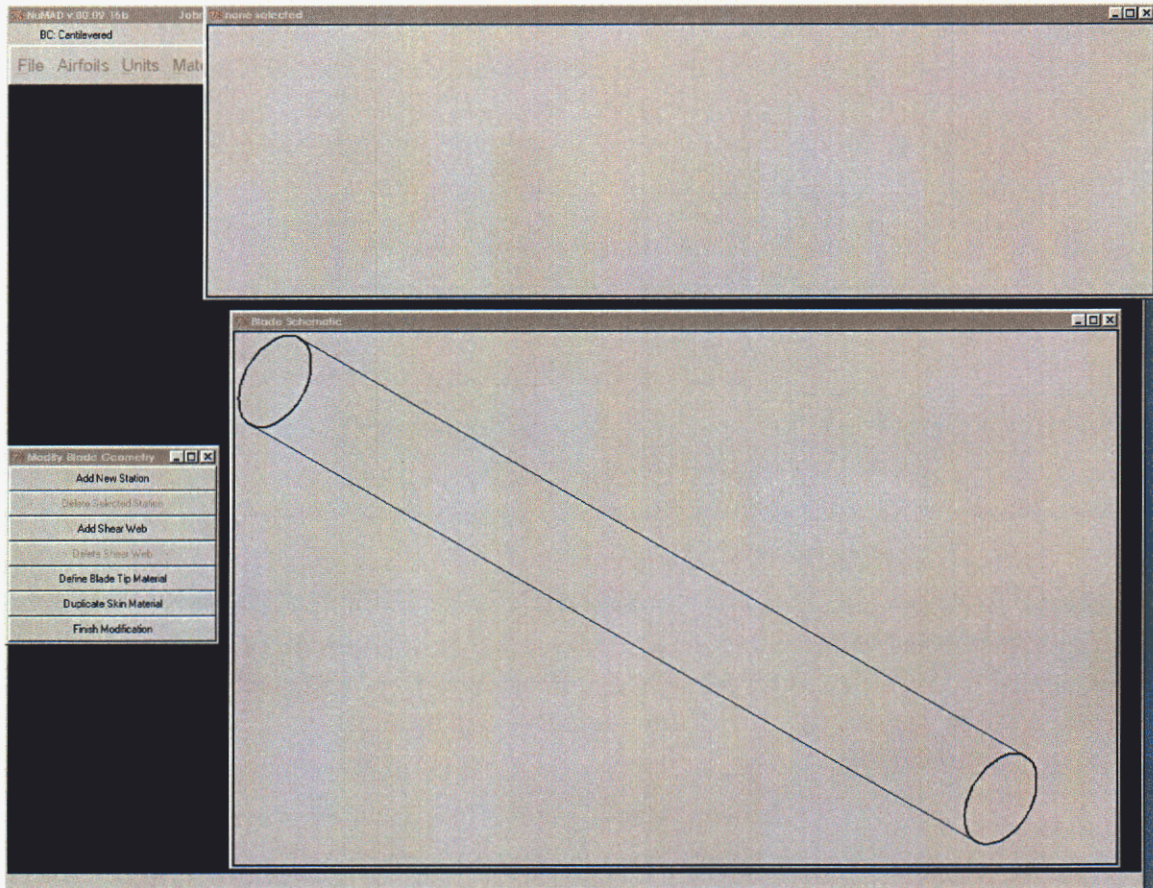

Figure 6.17 Blade geometry modification windows presented for a new blade model.

6.3.1 Stations

The exterior blade geometry is determined by an arbitrary number of stations. Each station is a particular airfoil profile or near the root it is likely to be circular or elliptical. The blade skin is “stretched” over the stations to create the blade geometry. The greater the number of stations present in the model, the greater the detail in the blade geometry. Most of the effort involved in defining a blade model lies in defining the stations.

6.3.1.1 Adding a Station

To add a new station to the model select “Add New Station” from the “Modify Blade Geometry” menu as shown in Figure 6.18. For the current example of a new model this will increase the number of stations from 2 to 3. At this point the user should select (with the cursor) a line segment on the blade schematic where the new station should be located. For our example, there is currently only one choice. One of the line segments between station 1 and station 2 must be chosen. The line segment will change from black to green when the cursor enters the line segment, then the user may select the line by depressing button-1 (left button on PC’s). The dialog box shown in Figure 6.19 will be displayed at the left if the user wished to cancel the process of adding a new station.

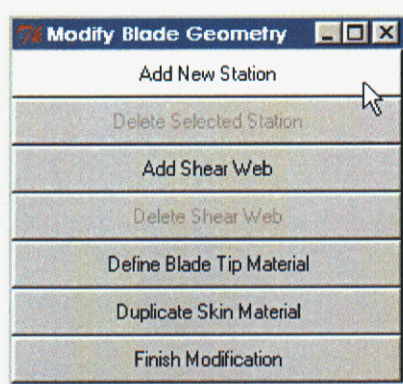

Figure 6.18 “Add New Station” entry selected from the “Modify Blade Geometry” menu.

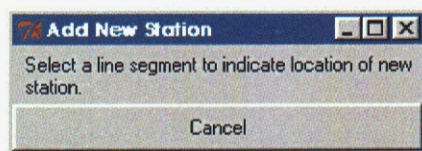

Figure 6.19 Dialog box allowing the user to cancel an “Add New Station” action.

Once the line segment has been selected, it changes color from green to red to let the user know that the selection was successful. The “Modify Blade Geometry” window disappears and two new windows are displayed as shown in Figure 6.20. These are the “Add Station” window and the “Choose Airfoil” window.

6.3.1.1.1 Airfoil Profile

At this point the user may choose an airfoil for the new station from the “Choose Airfoil” window. The airfoils listed are those that are present in the master airfoil profiles database and that contain the number of coordinate pairs specified in the method of external geometry input dialog box (Figure 6.8). For the example, airfoil profiles containing 32 coordinate pairs were specified in the external geometry input dialog box.

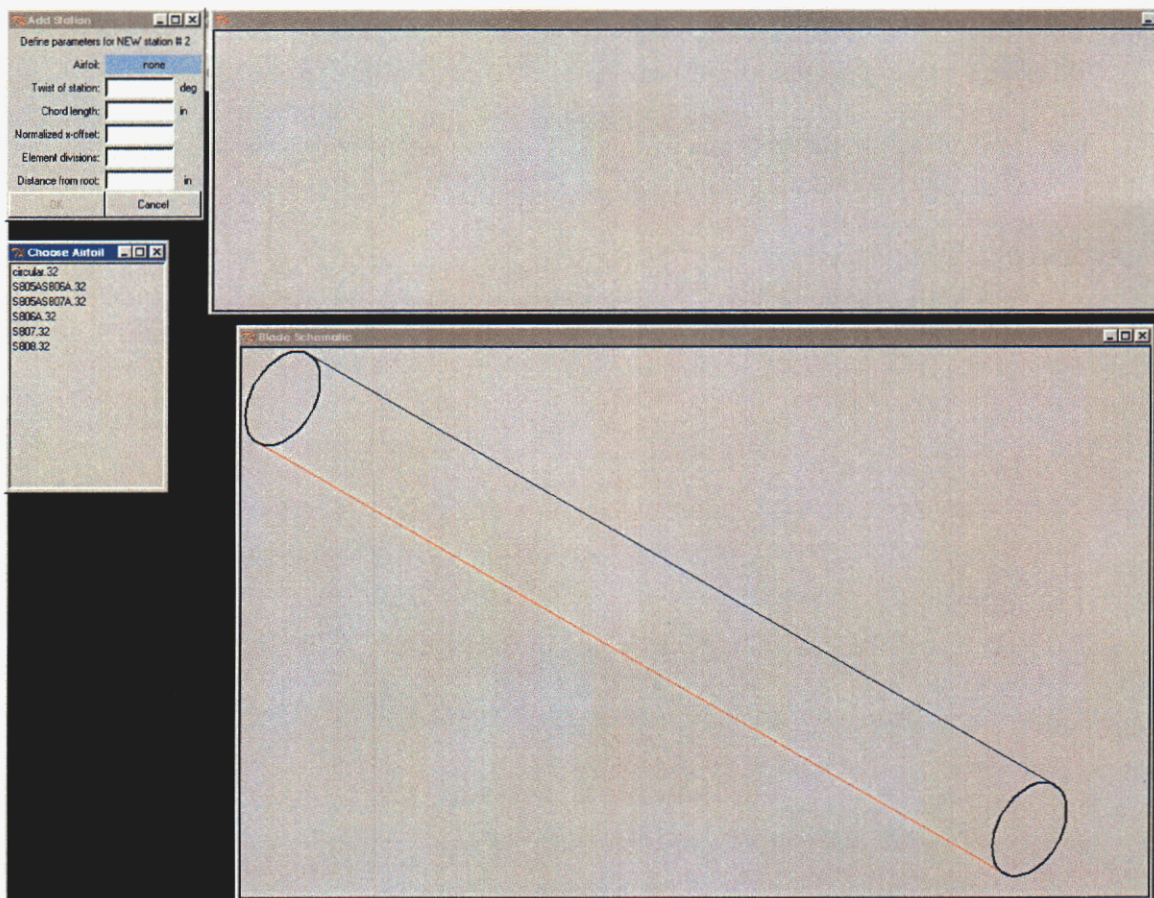

Figure 6.20 Blade modification environment after the location of the new station has been selected.

As the user drags the cursor over the airfoil profile names listed in the “Choose Airfoil” listbox, the corresponding airfoil is displayed in the airfoil display window at the upper righthand portion of the screen. The name of the airfoil profile becomes the title of the airfoil display window. When the user selects an airfoil with a left-click on the airfoil name, that name is inserted into the appropriate location in the “Add Station” window and the displayed airfoil no longer changes with cursor movement. A different airfoil may be selected at this point with another left-click on a different airfoil name. Continuing the example, the airfoil profile S808.32 was selected with the results shown in Figure 6.21.

6.3.1.1.2 Station Parameters

Other parameters defining the station may be defined next. The dialog box shown in Figure 6.22 has six station parameter names listed. The first parameter, Airfoil, is determined by the “Choose Airfoil” listbox as described in section 6.3.1.1.1. Next, the twist of the station may be directory input into the entry box in degrees. The positive twist of the station is clockwise as viewed from the blade root or counter-clockwise as viewed from the blade tip. The chord length of the station is the distance from the nose to the tail of the airfoil profile and is input in the currently selected units for length. The

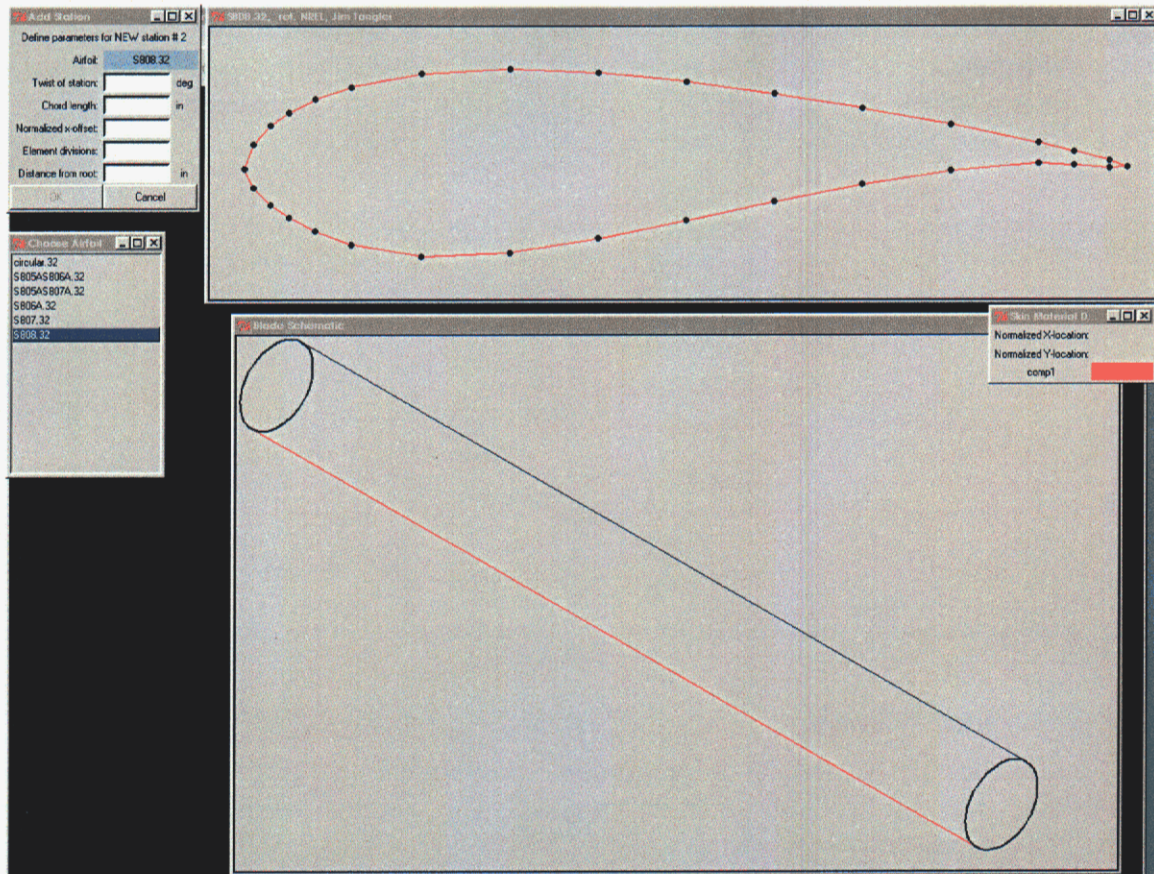

Figure 6.21 Blade modification environment after the airfoil for the new station has been selected.

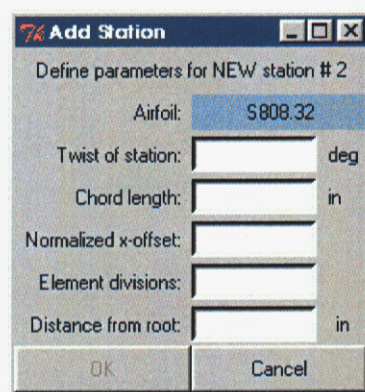

Figure 6.22 “Add Station” dialog box used to define numerous station parameters.

“Normalized x-offset” refers to the normalized distance that the nose of the airfoil is translated from the blade axis. Another description is that this is where the blade axis crosses through the station, often near 30% for airfoils and 50% at a circular root station. The parameter “Element divisions” refers to the number of finite elements in the axial direction that will be present between the current station and the subsequent station. This parameter is not defined for the final station describing the blade. Finally, the “Distance

from root” parameter indicates how far the current station should be from the blade root. Again the units are the currently selected units for length. The values used for the current example are shown in Figure 6.23. Only after all entry boxes have been filled will the “OK” button become active.

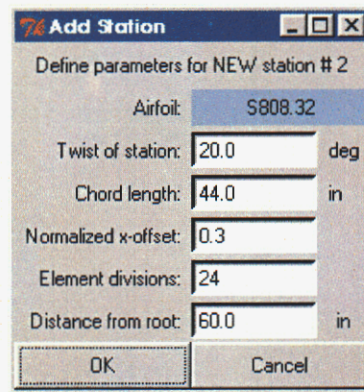

Figure 6.23 Station parameters used for example blade.

6.3.1.1.3 Skin Materials

To define the skin materials of the station, portions of the airfoil profile may be graphically selected and then materials assigned. The material definitions available are those present in the master materials database discussed in Chapter 5.

For the current example, the airfoil profile will be divided into five material sections and then three different composite materials will be assigned to the five material sections. To divide the profile into multiple material section segments, the user selects coordinate pair locations (indicated by black circles) with the cursor. As a pair location is selected, the color coding of the profile will change to indicate the new material division. The coordinate pair location will change from a black circle to a red circle. Figure 6.24 shows the S808 airfoil used in the example just after the fourth skin material division has been selected. The airfoil is now displayed in five different colors to indicate the five different material sections.

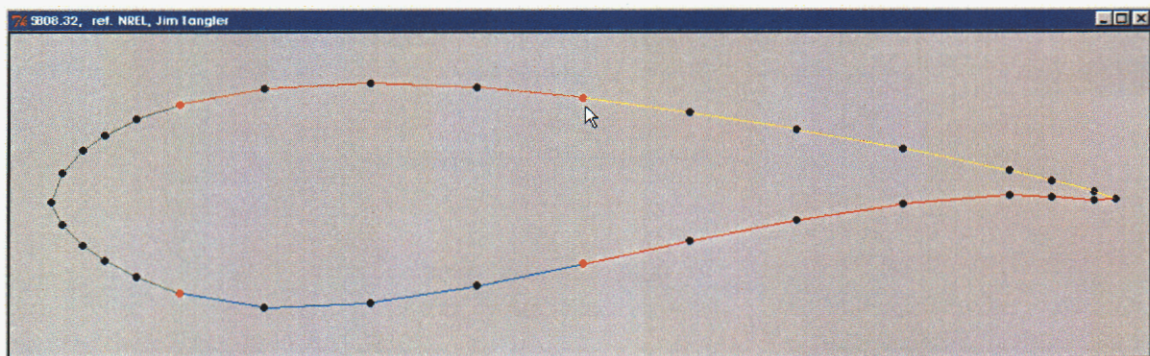

Figure 6.24 S808 profile divided into five material section by four skin material divisions.

The material corresponding to the color-coded portions of the airfoil are shown in a window below the airfoil. Just after selecting the skin material divisions this window appears as shown in Figure 6.25. The first material always defaults to the first material in the master materials database. The other materials are currently undefined. To define material sections two through five or to redefine material section one, the user graphically selects the actual material section as shown in Figure 6.26. In this figure, the fourth material section has been selected and it is displayed with thicker line segments. Once a material section has been selected, a listbox appears displaying the names of the composite materials in the master airfoils database. The user may select one of these composite materials and that material will be assigned to the active material section. Once a material has been assigned, the material section may be deactivated with a graphical selection and then another material section may be activated. This process is repeated until all material sections have been assigned a material.

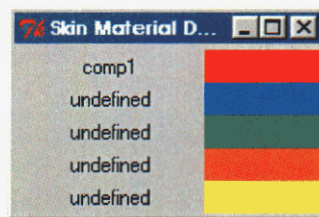

Figure 6.25 Guide to materials defined for the current airfoil

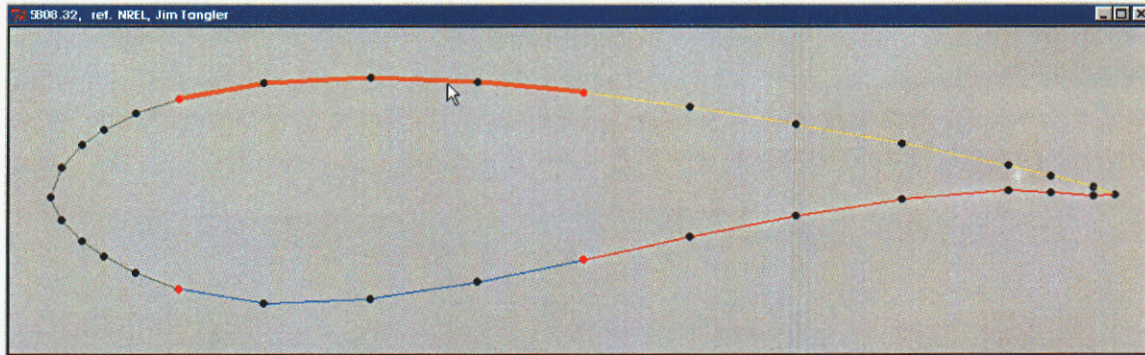

Figure 6.26 S808 profile with the fourth material section selected.

Once a composite material has been assigned to each of the material sections, the material names will be matched to the material section color code as shown in Figure 6.27. In this case the same composite laminate is being defined for the upper and lower surfaces of the tail section and a different composite laminate is being used for the upper and lower surfaces at the thickest portion of the profile.

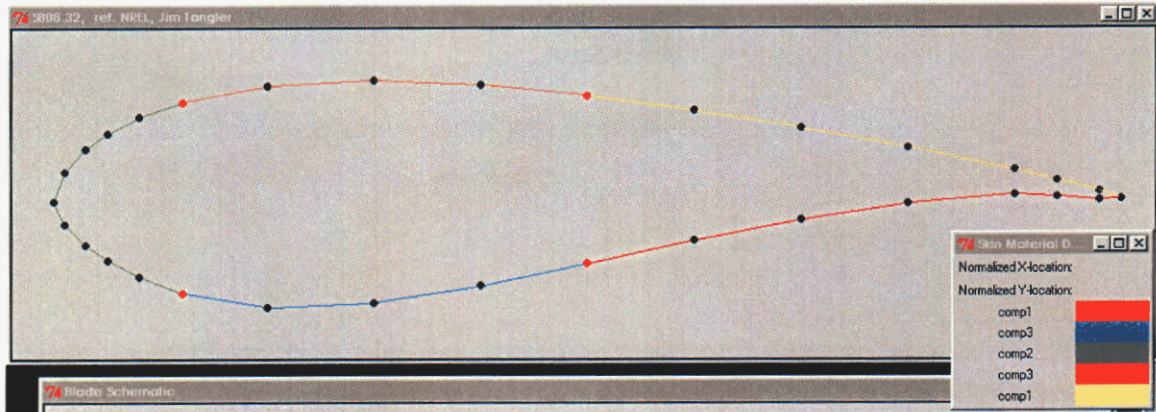

Figure 6.27 S808 profile after materials have been assigned to the five material sections.

Once all materials and station parameters have been defined, the “OK” button in the “Add Station” window becomes active. Thus the user is not allowed to incompletely define a new station.

The current example showed the selection of the airfoil first, followed by specification of the station parameters, skin material divisions, and finally selection of the materials. While this order of defining the station is logical, it is not required. The user could define the station parameters before defining the airfoil, or define the airfoil and materials before defining the station parameters.

For the current example, after the user selects “OK” from the “Add Station” window, the blade schematic shown in Figure 6.28 will be displayed. This is the current shape of the blade with three stations defined.

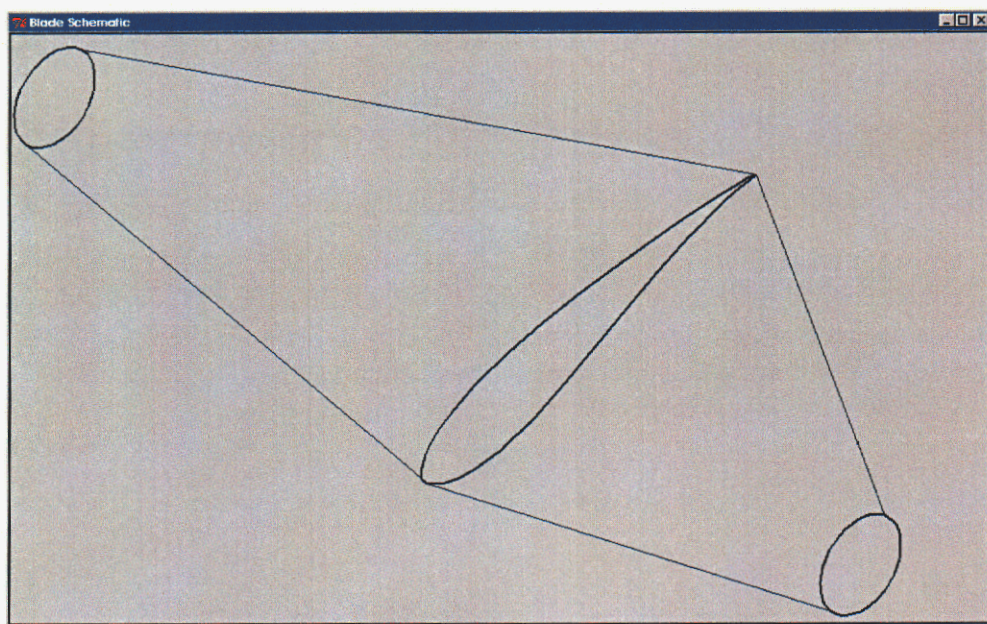

Figure 6.28 Blade schematic of example blade after addition of first new station.

Repeating the procedure outlined above, a fourth station is added to the example. This station is circular, indicating the end of the circular root section of the blade. It is located 18 inches from the root and the resulting blade schematic is shown in Figure 6.29.

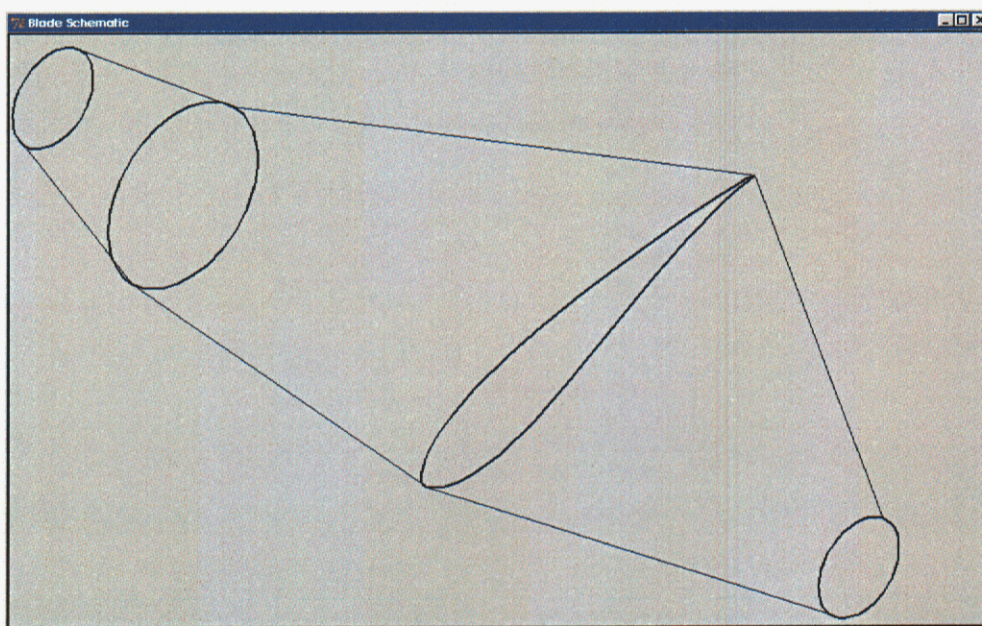

Figure 6.29 Blade schematic of example blade after addition of second new station (fourth total station).

6.3.1.2 Modifying Existing Station

The process to modify an existing station is similar to the process just described for adding a new station. The process to modify the last (fourth) station in the example will be described here to illustrate differences between adding a station and modifying an existing station.

To modify an existing station, the "Modify Blade Geometry" menu is not needed. The user need only drag the cursor over the station to be modified on the blade schematic. When the cursor first touches the representation of the desired station on the blade schematic, that station turns green, the profile is displayed, and the "Choose Airfoil" and "Modify Station" windows are posted. This allows the user to view the station information. If the user decides to modify the station, a left-click causes the station to turn red letting the user know that the station may now be modified. If the user does not select the station (left-click) then the "Choose Airfoil" and "Modify Station" windows will disappear when the cursor is moved away from the station on the blade schematic.

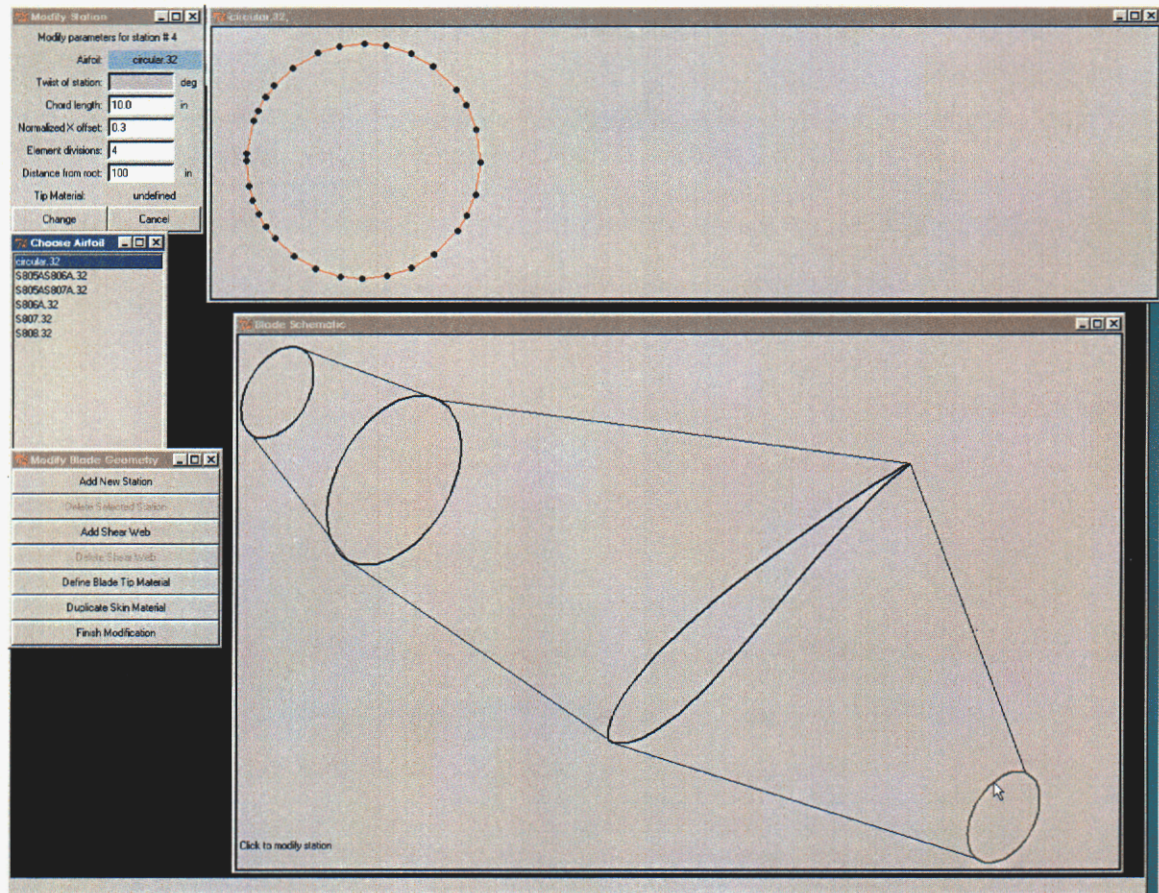

Figure 6.30 Screen shot of NuMAD as cursor passes over fourth station in the example blade.

If the station were selected, the station may now be modified in a fashion similar to that of adding a new station. A different airfoil may be selected from the “Choose Airfoil” listbox and the station parameters may be changed in the “Modify Station” window. In Figure 6.30, the entry box for “Twist of station:” is deactivated because the current airfoil selected is circular. When a non-circular airfoil profile is selected, the “Twist of station:” entry box becomes active. Also of note is the “Tip Material” label in the “Modify Station” window. When the final station in the blade is selected, the material chosen for the blade tip is displayed. In this case, a composite material has not yet been assigned for the blade tip. Another issue when the final station is selected is that skin materials may not be defined. Because the skin material definitions apply to portion of the model between the current and subsequent station, skin materials may not be defined at the final station because there is no subsequent station.

For the example blade, the final as well as initial stations were modified. The final station was changed to use an S806A airfoil and have a chord length of 13.0 inches, a zero degree twist, and 20 axial element divisions. The “Distance from root:” was changed from 100 inches (default value for new model) to 312 inches. Of course, the distance from root of the final station is also the total blade length so this change extends the blade to 312 inches long. In a similar manner, the first station was modified to have a

chord length of 16.5 inches and a normalized x-offset of 0.5. The entry box for “Element divisions:” is not active when the first station is selected because this value specifies the number of elements in the axial direction between the current station and the previous station. Thus this value is undefined for the first station in the model. The distance from root for the first station is also inactive and the value set to 0.0. This is required for the first station in the model. Once both the final and first stations in the model have been modified, the resulting blade schematic is shown in Figure 6.31.

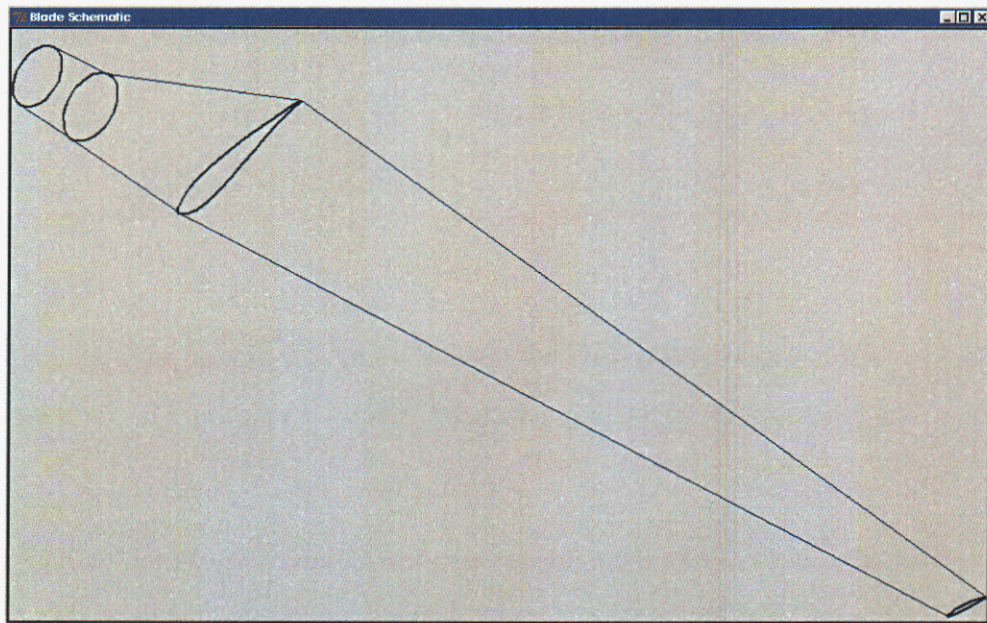

Figure 6.31 Blade schematic for blade example after four stations have been added or modified.

6.3.1.3 Deleting a Station

Deleting an existing station is very simple. First, select a station from the blade schematic as described in section 6.3.1.2. This is the same first step in the process to modify an existing station. Once the station has been selected, the “Delete Selected Station” button on the “Modify Blade Geometry” menu will become active. Selecting this button will cause the currently selected station to be deleted. The blade schematic will automatically be regenerated to reflect the change in the blade profile.

6.3.2 Shear Webs

Shear webs are internal structural members used to carry loads and maintain the blade shape. In terms of modeling, shear webs may be used within NuMAD to model box beams as well as simple shear webs.

6.3.2.1 Adding a Shear Web

To add a shear web to the blade model select the “Add Shear Web” button from the “Modify Blade Geometry” menu. This action posts the “Add New Shear Web” window

shown in Figure 6.32 as well as the composite materials listbox. The “Add New Shear Web” window indicates that the user is adding shear web #1 and has entry boxes for the user to input the stations at which the shear web should begin and end. The “Number of elements:” entry refers to the number of elements along the length of the shear web and this value defaults to four elements. The user may choose the material for the shear web through the composite materials listbox and, once selected, the name of the material will appear in the “Add New Shear Web” window.

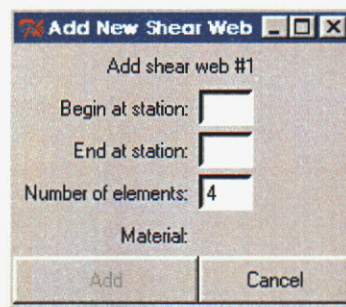

Figure 6.32 Input window to specify parameters defining a new shear web.

As soon as the user specifies the station at which the shear web should begin, the airfoil profile assigned to that station is displayed. For the current example, a value of three was specified for the beginning location of the shear web so the airfoil assigned to station three (S808) is displayed as shown in Figure 6.33. The user may now define a shear web by simply selecting two coordinate pair locations (black dots). After the first coordinate pair location is selected, a line segment representing the shear web will be drawn from the coordinate pair to the cursor. This line segment will follow the cursor until the user selects another coordinate pair location which becomes the end of the shear web. Figure 6.34 shows the airfoil profile just after the second coordinate pair location has been selected. A line segment representing the shear web is drawn in red and the shear web number, 1, is placed next to the line segment.

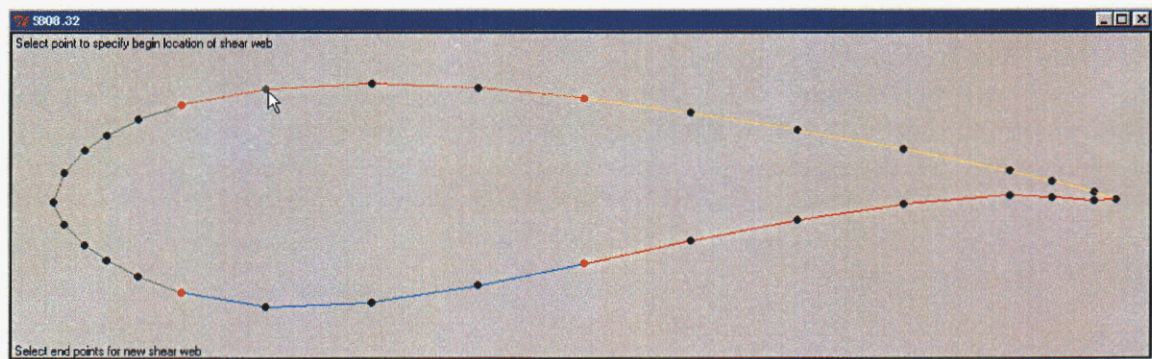

Figure 6.33 Selecting the beginning location of a shear web.

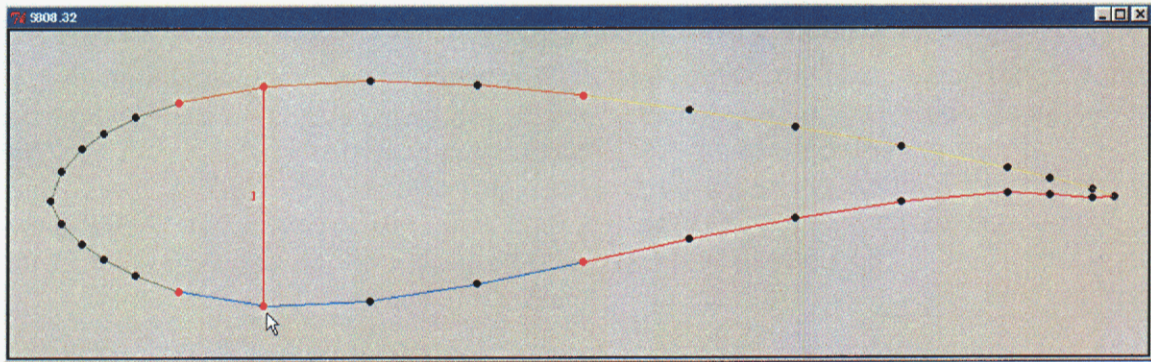

Figure 6.34 Selecting the end location of a shear web. The shear web number is placed next to the shear web representation.

To complete the definition of the shear web, the user need only enter an end station for the shear web (4 in this case) and verify that a material has been selected. After the user has selected the “Add” button from the “Add New Shear Web” window, the blade schematic is updated as shown in Figure 6.35. While it is unlikely that a real shear web would extend to the tip of the blade, a shear web must begin and end at a station and our simple example has only four stations.

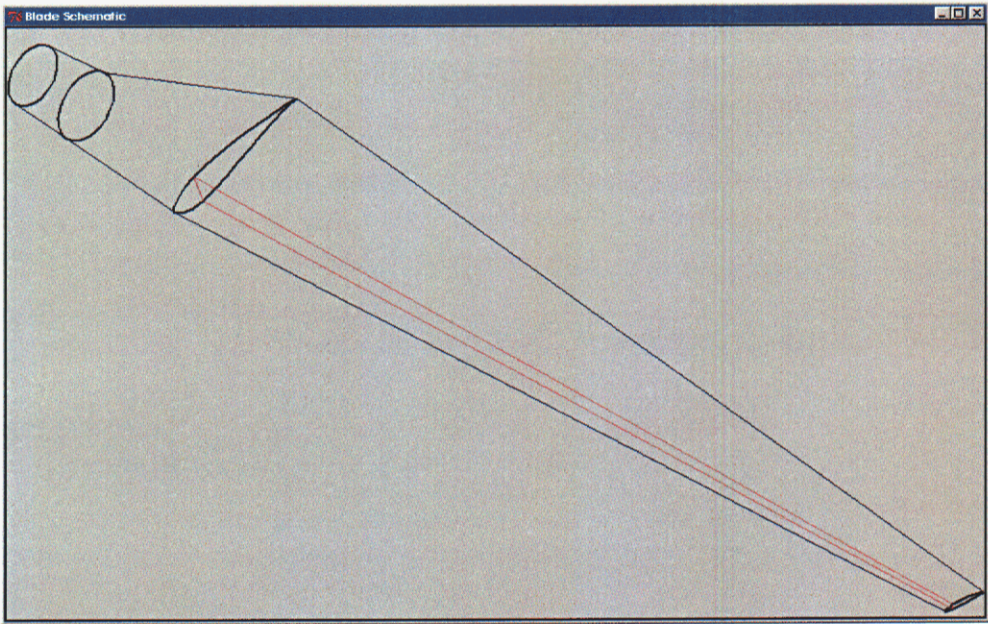

Figure 6.35 Blade schematic for example after a shear web has been added.

The procedure to add a new shear web may be repeated as many times as needed to add any number of shear webs.

6.3.2.2 Deleting a Shear Web

To delete a previously defined shear web, select the shear web from the blade schematic. Choose the “Delete Shear Web” button from the “Modify Blade Geometry” menu at the left. The selected shear web will be deleted and the blade schematic updated.

6.3.3 Spanwise Material Tapering

For the very rapid creation of blade models, a capability to approximate the many ply-drops which exist along the length of the blade is necessary. For a first pass model (such as the current example), it would be extremely time-consuming to define each of the unique material definitions and blade stations required to model a blade material which has ply-drops at relatively regular intervals. To handle this situation, NuMAD allows a target thickness to be independently assigned to each layer in a composite material section. One or more layers may remain at constant thicknesses while others taper.

For the extremely simplified current example, the approach is to specify the skin material properties at a selected station (3) and then specify target layer thicknesses for station 4 (blade tip). NuMAD will then step-taper the material between the two stations based on the number of element divisions that the user specifies between the two stations.

First, a station may be selected from the blade schematic as mentioned in section 6.3.1.2. Next, a blade skin material section may be specified by selecting the corresponding portion of the airfoil profile of the blade station which bounds the material section on the inboard side. For example, Figure 6.36 shows the selection of a portion of the airfoil profile (green segments) on the low-pressure side. This portion of the blade was previously defined to be a composite material containing three layers.

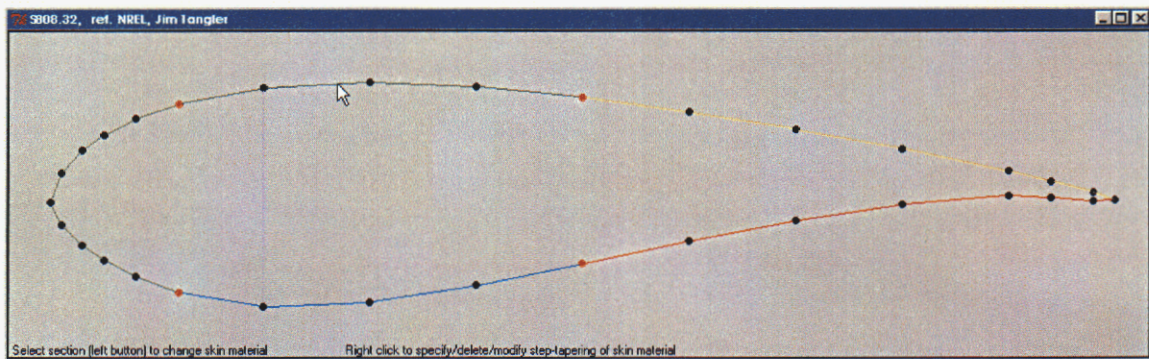

Figure 6.36 Selection of material section for spanwise material tapering.

Once this blade portion is selected for specification of spanwise tapering, an input window (Figure 6.37) appears which lists all layers present in the composite material as well as the initial thickness values and entry boxes for the input of final (target) thickness values for each layer. The user may then specify final layer thickness values for each layer individually. The final thickness values may be greater than, less than, or equal to the initial layer thickness values. In this case, the subsequent station is station 4, the blade tip.

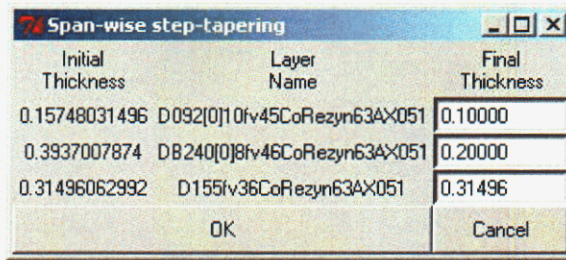

Figure 6.37 Input window allowing final layer thickness values to be specified.

Within ANSYS®, the composite material will be step-tapered in the axial direction of the blade. The material definitions will change with each "ring" of elements along the blade axis. The NuMAD user specifies how many elements are desired in the axial direction between stations. Thus the definition of the actual elements created within ANSYS® is completely dependent on this user-specified mesh density in the axial direction.

To continue with the current example, a mesh density of twenty elements was specified between station three and station four (blade tip). For the strip of elements highlighted in Figure 6.38, the varying thickness of the elements is displayed in Figure 6.39. The thicknesses of the elements in Figure 6.39 have been exaggerated (20x) so that the variations in layer thickness are visible. The outer layer (uppermost) is constant thickness corresponding to layer 1 in the input window shown in Figure 6.37. The middle layer tapers down to one half of its original thickness and the interior layer tapers significantly as well.

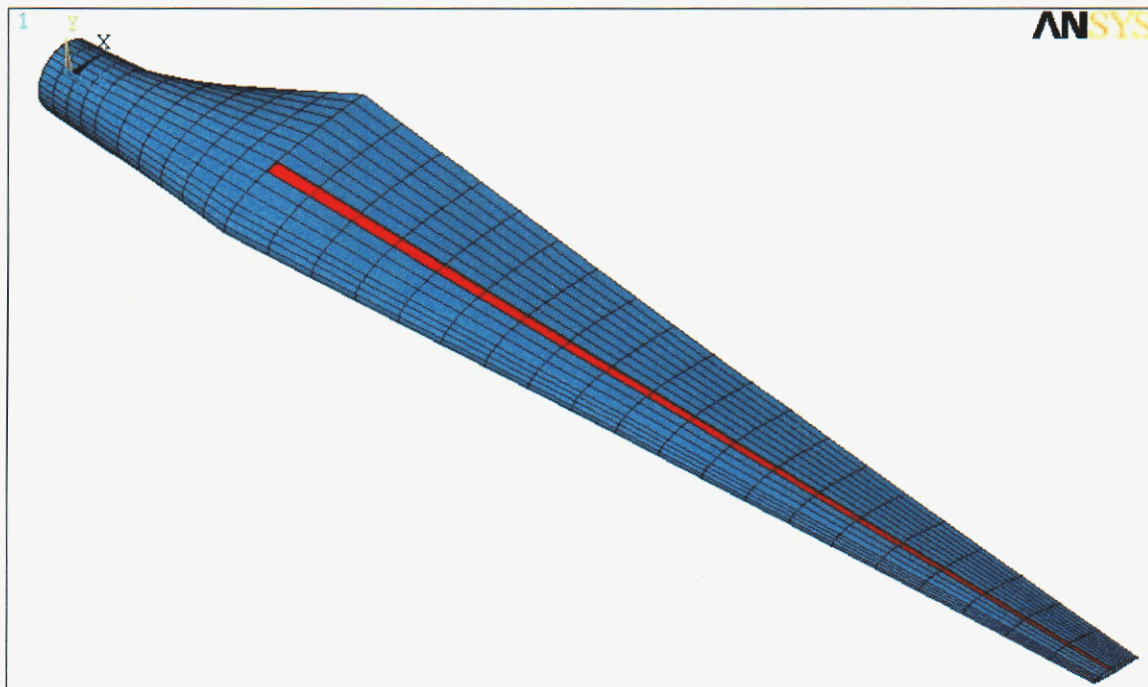

Figure 6.38 Portion of finite element model (red) selected to demonstrate the skin material “tapering” represented in .

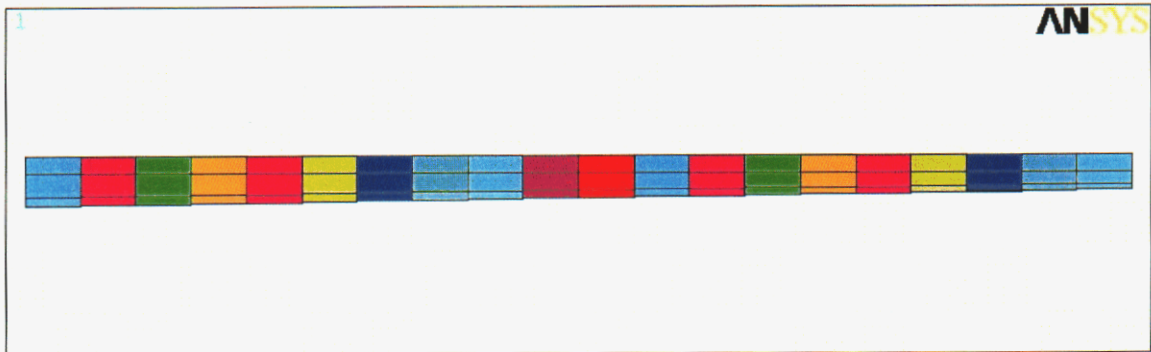

Figure 6.39 Thickness representation (exaggerated) of composite material based on ANSYS real constant definitions. Twenty elements in direction of blade axis.

Figure 6.40 shows the relative thicknesses of the same strip of elements for the same blade model but with an axial mesh density of only four elements. Obviously, the analysis results will be dependent on the axial mesh density chosen. The axial mesh density between station 3 and station 4 was chosen when modifying station 4.

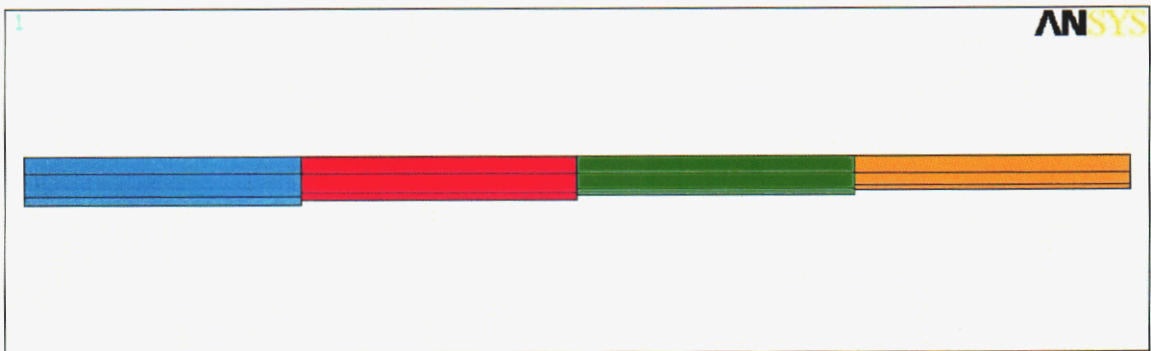

Figure 6.40 Thickness representation (exaggerated) of composite material based on ANSYS real constant definitions. Four elements in direction of blade axis.

Each blade skin material section may have its own schedule of target layer thicknesses even if the initial materials refer to the same composite. The spanwise material tapering capability of NuMAD allows first-pass models to be created quickly.

CHAPTER 7 **Loads and Boundary Conditions**

Once the blade geometry and materials have been specified, the user must indicate the desired analysis types, loads, and boundary conditions. Following is a description of the necessary procedures.

7.1 Analysis Type

The analysis type refers to the type of analysis to be performed by ANSYS®. NuMAD currently includes four categories as shown in Figure 7.1. Though the first analysis type, mass distribution, may not appear to be an analysis, it involves performing a number of partial ANSYS® solutions and is thus included in this list.

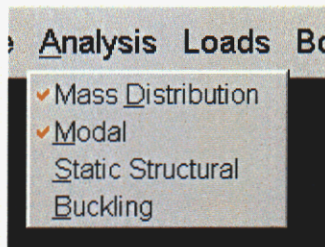

Figure 7.1 Analysis menu with “Mass Distribution” and “Modal” selected.

7.1.1 Mass Distribution

If the mass distribution analysis type is selected, a text file named *MassDist.txt* will be produced during the solution of the model. This file contains a list of mass values followed by the range of distances from the blade root which bound the mass. The number of mass values calculated depend on the number of elements in the axial direction contained in the model. The number of elements in the axial direction is specified by the NuMAD user through the station parameters. If, for example, station 2 is 18 inches from the root and the NuMAD user has requested 6 elements in the axial direction, the resulting mass distribution would include mass values for zero through 3 inches from the root, 3 to 6 inches from the root and so on.

7.1.2 Modal

A modal analysis is performed to determine the natural frequencies and mode shapes of a structure.

7.1.3 Static Structural

The static structural analysis refers to both a distributed pressure load and a concentrated tip load. The distributed pressure load is called a hurricane load though any pressure value may be used.

7.1.4 Eigenvalue Buckling

This type of analysis is used to calculate the buckling loads and determine the buckling mode shape.

7.2 Specifying Loads

The loads for the analysis are specified through the Loads menu. Not all loads are applicable to all analysis types so the entries active in the Loads menu depend upon which analysis types are selected in the Analysis menu. Figure 7.2 shows the loads menu when a modal analysis has been selected in the Analysis menu and the static structural analysis type is not selected. Thus the “# of Modes” and “Spin Rate” entries in the Loads menu are active but the “Tip” and “Hurricane” entries are not. If the “# of Modes” entry is selected then the number of modes to be obtained during the analysis may be specified through the input window shown in Figure 7.3.

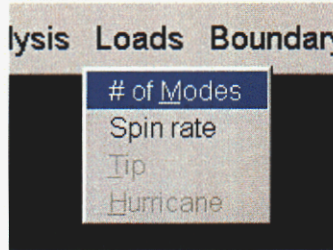

Figure 7.2 Loads menu, “# of Modes” entry selected.

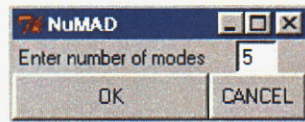

Figure 7.3 Input window for specifying the number of modes for a modal analysis.

A modal analysis may also be performed on a prestressed blade such as a spinning blade. After “Spin rate” is selected from the Loads menu (Figure 7.4), a spin rate value may be input into the window shown in Figure 7.5. This will cause ANSYS® to perform a preliminary analysis to determine the prestressed state of the blade before performing the modal analysis.

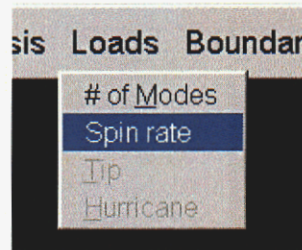

Figure 7.4 Loads menu, “Spin rate” entry selected.

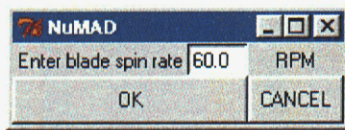

Figure 7.5 Input window to specify a blade spin rate.

Figure 7.6 shows the loads menu when a static structural analysis has been selected in the Analysis menu and the modal analysis type is not selected. Thus the “# of Modes” and “Spin Rate” entries in the Loads menu are inactive but the “Tip” and “Hurricane” entries are active. If the “Tip” entry is selected (Figure 7.6) then the magnitude of a concentrated tip load may be specified through the input window shown in Figure 7.7. The tip load may have both a plan component and an edge component.

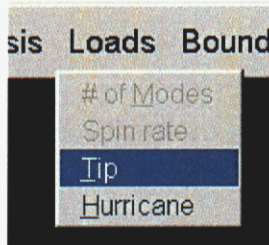

Figure 7.6 Loads menu, concentrated “Tip” load selected.

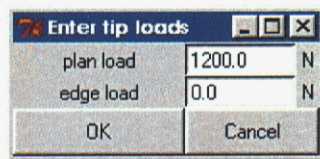

Figure 7.7 Input window for concentrated tip load.

Lastly, a distributed pressure load may be defined by selecting “Hurricane” from the Loads menu (Figure 7.8). This causes the input window shown in Figure 7.9 to post and allows the user to set a distributed pressure load. The “Enter hurricane load” window allows direct user input for the wind speed, elevation, and temperature. It then calculates a pressure load. If the user knows the pressure load originally, a dummy wind speed may be used to obtain the desired pressure load. The “Enter hurricane load” window also allows the user to select whether or not to perform a non-linear geometry solution. This is sometimes called a “large deflection” solution. Though the non-linear geometry solution should be more accurate, it is computationally expensive and does not yield significantly different results for small deflection analyses. Figure 7.10 shows a schematic of how the pressure load is actually applied. The pressure load is always perpendicular to the surface of the blade on the high pressure side.

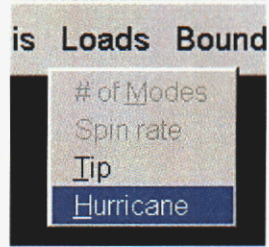

Figure 7.8 Loads menu, "Hurricane" or distributed pressure load selected.

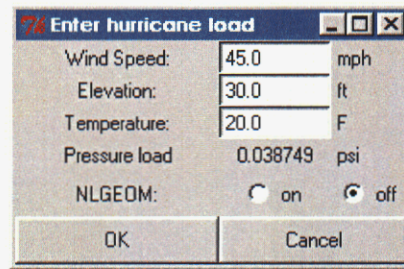

Figure 7.9 Input window for specifying a distributed pressure load.

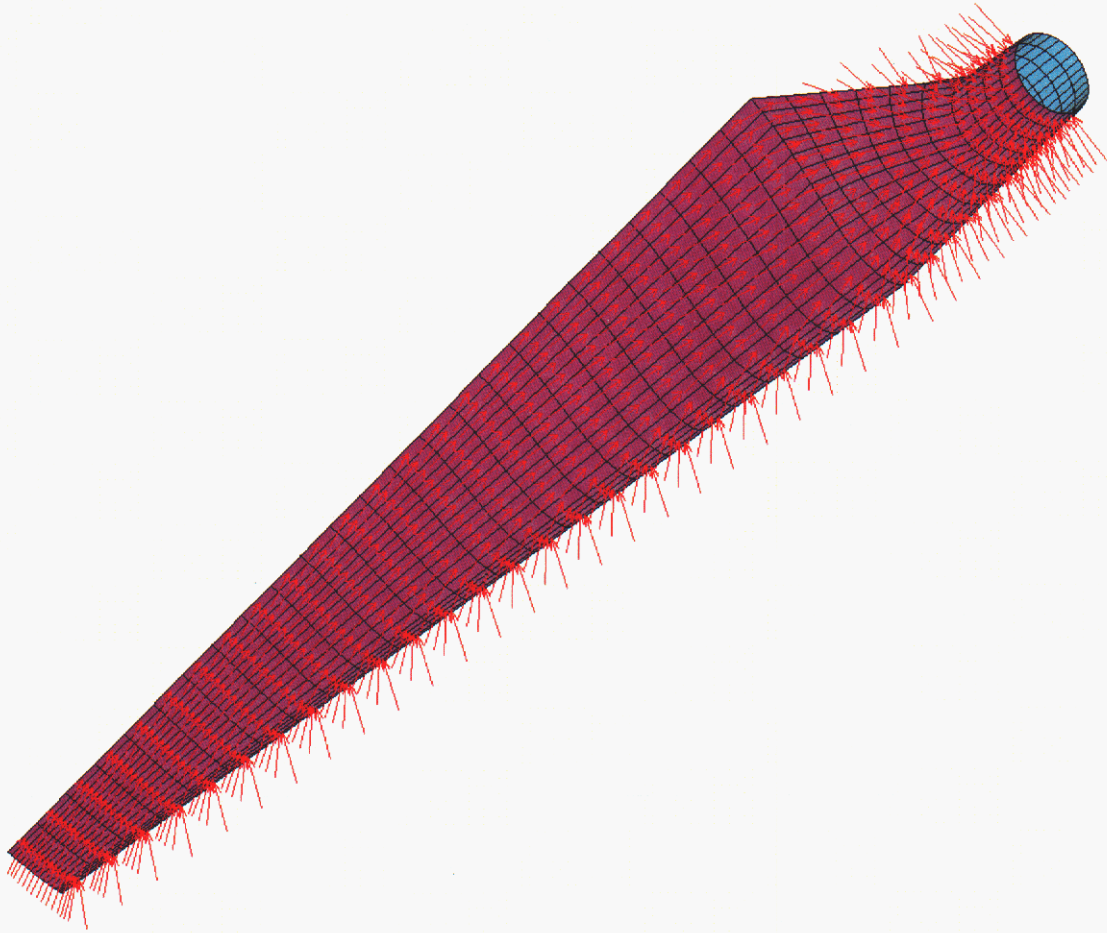

Figure 7.10 Schematic of distributed pressure load on the underside (high pressure side) of blade.

7.3 Boundary Conditions

The boundary conditions for the analysis are generally cantilevered but for a modal analysis the user has the option to specify free-free boundary conditions. The free-free boundary conditions may be useful to match experimental results. If the cantilevered case is used (Figure 7.11), the nodes at the blade root are fixed in all translational degrees of freedom as well as all rotational degrees of freedom.

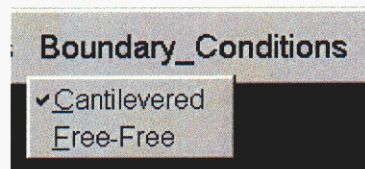

Figure 7.11 Boundary conditions menu with the cantilevered entry selected.

CHAPTER 8 **Output**

The output produced by a NuMAD/ANSYS solution consists of the files created by ANSYS during solution and the default NuMAD output which consists primarily of graphical output displaying strains, mode shapes, etc.

8.1 Graphical File Formats

During solution, graphical output is generated in one or more file formats. These formats may be selected from the “Output” pull-down menu from the main menubar. The three formats currently available are postscript, TIFF, and JPEG. Each format has its advantages and disadvantages and any combination of the three may be chosen for a particular analysis. These formats are discussed in more detail in Appendix A.

Figure 8.1 shows the “Output” menu with both postscript and JPEG output selected. The rasterized formats, TIFF and JPEG, have three different resolutions from which to choose. In Figure 8.1, a resolution of 1000 pixels by 750 pixels has been selected for the JPEG output.

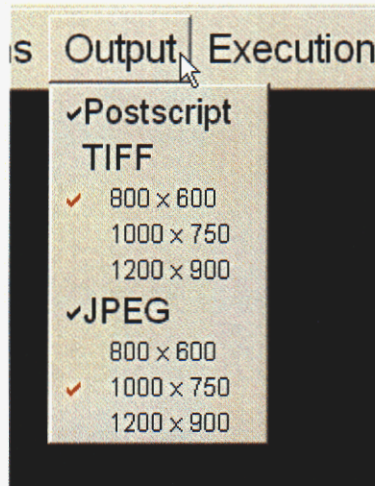

Figure 8.1 “Output” menu from the main menubar. Both postscript and JPEG graphical output are selected.

8.2 ANSYS Data

During solution, ANSYS®-generated files which do not correspond to a particular analysis are placed in the jobname directory. These files include

- master.db
- master.emat
- master.erot
- master.esav

The file *master.db* contains the ANSYS® database information describing the model dimensions, material properties, load data, etc. The element matrices are stored in the file *master.emat* and the rotated element matrices in the file *master.erot*. The element saved data is stored in *master.esav*.¹ To verify that the blade geometry, material properties, or loadings were properly created, the user may launch ANSYS® and resume *master.db*. These files may also be copied to a different directory for manual modification within ANSYS®.

Another file left in the jobname directory is *output.txt*. This file contains a complete log of all commands sent to ANSYS® by NuMAD and the ANSYS® response for each command. For even moderately complex models, the *output.txt* file may be several thousand lines in length. This file should be perused by the NuMAD/ANSYS® user to verify that all ANSYS®-issued warnings are acceptable and that model generation and solution have occurred as intended by the user.

The ANSYS-generated files specific to a particular analysis are located within the directory structure corresponding to that analysis. Within the jobname directory, the analysis results are subdivided into directories corresponding to the type of analysis. At this level all analyses are grouped into structural or modal analyses with the corresponding directory names “struct” and “modal.” The “struct” directory may then be further delineated into directories named “tipload” or “hurrican.” The hurricane load refers to a distributed pressure along one side of the blade and the tip load case refers to a concentrated load at the blade tip. The ANSYS-generated files present in the “tipload” directory are

- tip.db
- tip.emat
- tip.esav
- tip.mntr
- tip.tri
- tip.rst

The files with the .db, .emat, and .esav extensions have the same function as the corresponding files with the *master* filename root. The stiffness matrix for the model is stored in the *tip.tri* file and the results of the analysis are stored in *tip.rst*.

Corresponding files are generated for each of the other analyses. The filename roots are *hurr* for a distributed pressure load, *buck* for an eigenvalue buckling analysis, and *modal* for a modal analysis.

8.3 Graphical Output

The graphical output produced by NuMAD is placed in the directories named for the type of analysis performed (tipload, hurrican, modal). Within these directories the graphical output is subdivided into directories named for the format of the images. The three graphical image formats currently supported by NuMAD are encapsulated PostScript

(eps), tagged image file format (TIFF), and Joint Photographic Experts Group (JPEG). These file formats are described in more detail in Appendix A.

By default, color contour plots of various strains for each of the material layers present in the model are created. The file names indicate the data displayed such as *SkinLayer1bottomex.jpg*. The first portion of the filename, *skin*, refers to either the blade skin materials or the shear web materials. The next portion of the filename, *Layer1*, refers to the layer number of the material. Next, *bottom*, refers to the bottom surface (as opposed to the top surface) of the layer as defined by the element. The final portion of the filename root, *ex*, refers to strain in the element X-direction and the extension, *jpg*, indicates the image file format (Appendix A). Quite a large number of plots may be created due to the fact that an image is created for strain in each of the three element directions (X, Y, Z) for each layer in the skin materials and each layer in the shear web materials for both the top and bottom surfaces.

Figure 8.2 shows an example of the default graphical output. This example is for a model with a 300 pound tip load. The strain is at the interior side (top) of layer 10 for the skin materials. It should be noted that the high strain region of the upper surface of the blade seems to stop abruptly at about the 75% station. This is due to a material change at this location in the blade. A few plies are dropped and there is no layer 10 past 75% station. Thus the green contour indicated for the outboard section of the blade corresponds to zero strain. Again, similar plots are generated automatically for all layers, both surfaces, and in the shear webs as well as the skin materials.

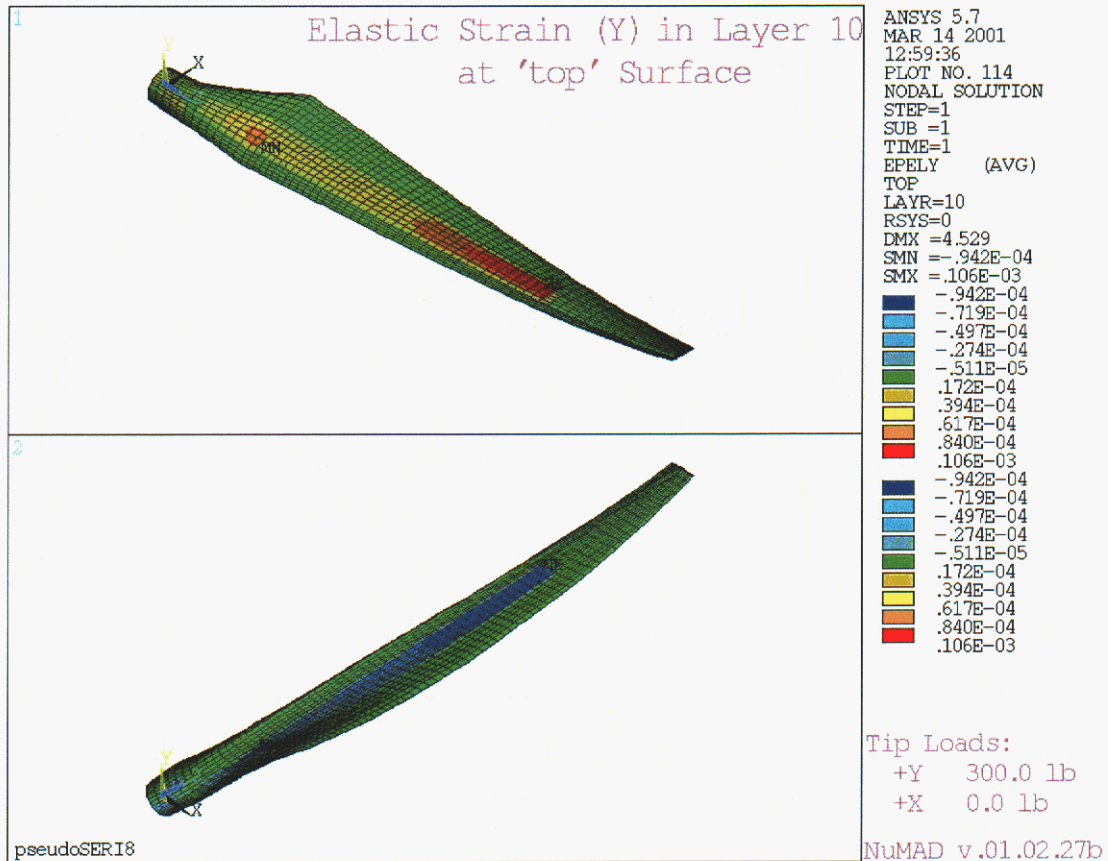

Figure 8.2 Example of default graphical output for tip load case.

8.4 Mass Distribution

If the mass distribution option is selected by the user, a text file is created with a tabular listing of the mass values along the blade model. The filename is *MassDist.txt* and it is located in the root jobname directory.

¹ ANSYS 5.7 Documentation

CHAPTER 9 **Launching the Analysis**

Once the blade geometry has been defined as well as the materials, loadings, etc., the ANSYS batch solution may be launched. The analysis may be started immediately or a time delay may be specified.

9.1 Incomplete Data

If some of the data defining the blade has not been defined, a warning dialog box such as the one shown in Figure 9.1 will be displayed. This prevents the user from launching an ANSYS® batch solution for an incomplete model which would cause the solution to fail.

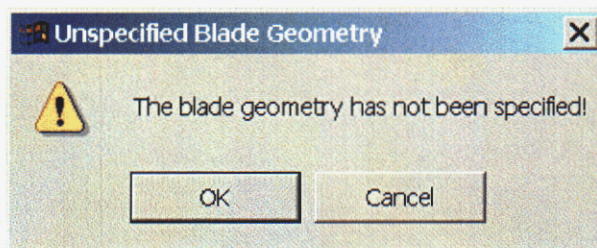

Figure 9.1 Warning issued if an analysis launch is attempted with no blade geometry definition.

9.2 Launching a Finite Element Analysis

A finite element analysis of a NuMAD/ANSYS® model may be launched for a previously created model which has not been opened or for the model currently open.

9.2.1 Existing Model

To launch an immediate analysis of a model saved previously, simply select "Launch Existing Model" from the "File" pull-down menu (Figure 9.2). The user is then asked to select any file in the appropriate directory (folder). Once a file is selected, the analysis will begin. This method does not read the model into NuMAD and it does not allow for delayed execution. For delayed execution of a previously saved model, first "Open Existing Model" and then specify a delayed execution through the "Execution" menu.

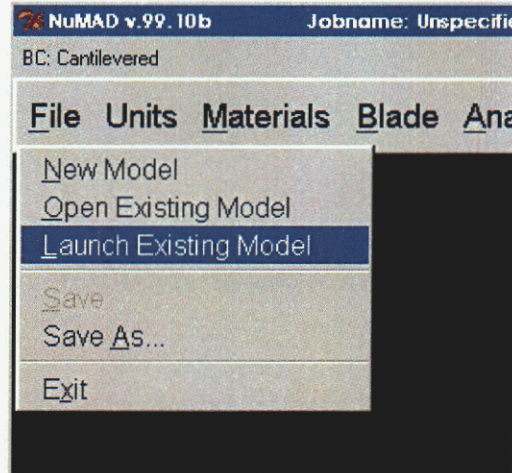

Figure 9.2 Launching a previously created model from the “File” menu.

9.2.2 Current Model

The current model is simply the NuMAD model in memory. This may be either a newly created model or a previously created model opened with “Open Existing Model” through the “File” menu.

9.2.2.1 Immediate Execution

To launch an immediate analysis of the model currently in memory, simply select “Launch Now” from the “Execution” pull-down menu (Figure 9.3). If all the blade data has been entered, the NuMAD application will be withdrawn and the ANSYS® solution will begin.

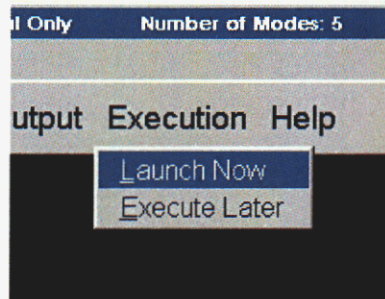

Figure 9.3 Starting an immediate ANSYS analysis from the “Execution” menu.

9.2.2.2 Delayed Execution

The analysis may also be scheduled to take place at a specified time in the future. For instance, the NuMAD user would often want to delay the execution of a complicated blade model until after work hours so that the analysis could take place overnight. This may be accomplished by selecting “Execute Later” from the “Execution” pull-down menu (Figure 9.4).

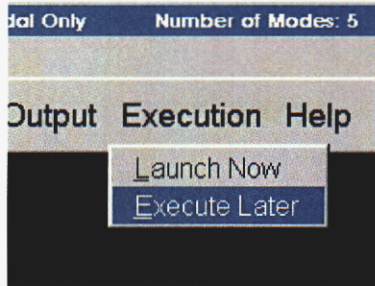

Figure 9.4 Selecting a delayed ANSYS analysis from the “Execution” menu.

The "Set Delay" dialogue box should appear (Figure 9.5). This allows the user to specify how long NuMAD should wait before launching the batch job to ANSYS®. The batch job will only be launched if the host computer is on continuously from the time the job is scheduled until the time the analysis is to begin. Of course, the host machine must also be on during the analysis.

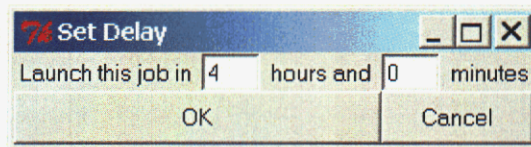

Figure 9.5 Input window used to set the delay for ANSYS analysis.

Once the delay has been set, a small countdown window (Figure 9.6) appears in the lower right corner of the user's display. This window gives a running update as to when the job launch will occur. This window may be minimized but it may not be canceled without destroying the job request.

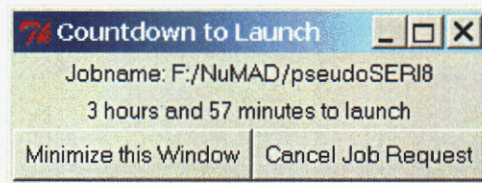

Figure 9.6 Countdown window used to provide the jobname and time until launch.

CHAPTER 10 Example Blade Analysis

A brief example analysis is demonstrated here. The blade modeled is nominally a SERI-8 blade manufactured in the 1980's. Some aspects of the blade have been simplified to make this example more concise and some assumptions were made due to incomplete data. This example demonstrates the manual geometry generation method rather than the automatic method. The blade model developed is more than adequate to demonstrate the procedural use of NuMAD. A large number of figures are employed in this section to make the process as clear as possible.

10.1 Creating a New Model

The first time NuMAD is launched, it searches for the existence of the file *settings.txt*. This file contains the pathname to the ANSYS® executable if it exists. If the file *settings.txt* does not exist, then the user is asked to specify the location of the ANSYS® executable or indicate that the host machine does not have an ANSYS® license.

10.1.1 Specifying the Jobname

The first step in defining a new model is to specify the jobname. This is accomplished by selecting the “New Model” item from the “File” menu on the main NuMAD menubar as indicated in Figure 10.1. The user is then presented with a standard dialog box to enter the jobname (Figure 10.2). While the default path for the new model matches the path to the NuMAD executable, the user may navigate to any location on the mapped drives. In Figure 10.2, the new jobname is “pseudoSERI8.” Once the user hits the “Save” button, a new folder (directory) with the name “pseudoSERI8” will be created and all data relating to this model will be saved in the new folder.

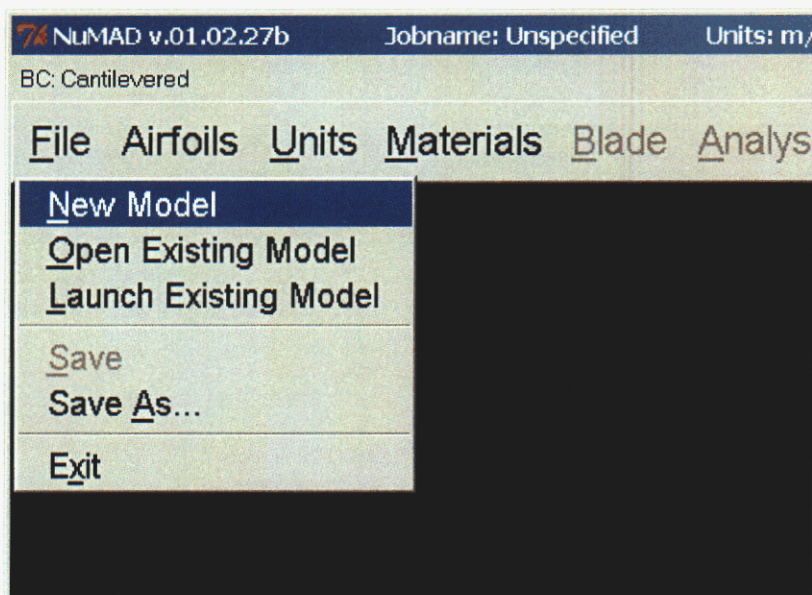

Figure 10.1 “New Model” entry selected from the File menu.

Once the jobname has been specified, the dialog box (Figure 10.2) disappears and the main NuMAD window is again visible as shown in Figure 10.3. Note that the jobname listed in the titlebar has now changed to include the full pathname of the current jobname. All pull-down menus are now active and may be accessed in any order by the NuMAD user.

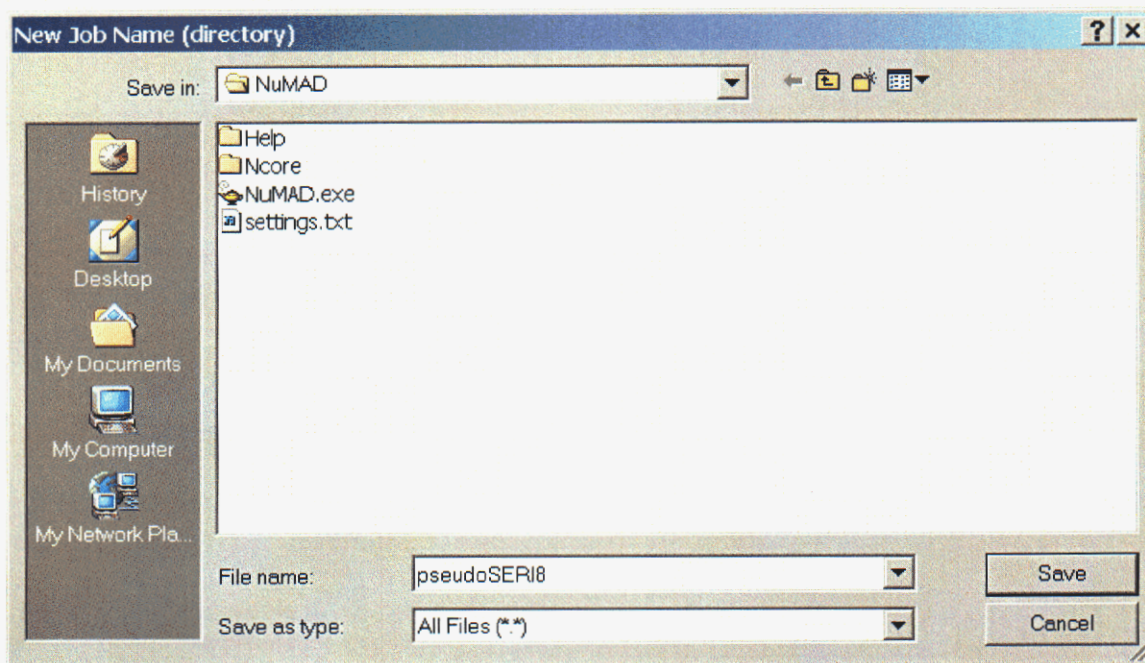

Figure 10.2 Dialog box for specifying a new NuMAD job name. In this example, the new job name is “pseudoSERI8.”

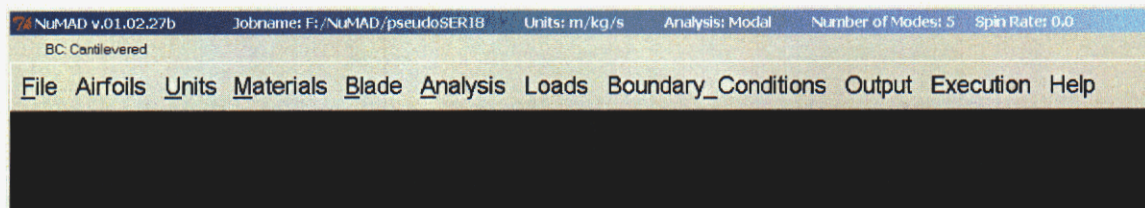

Figure 10.3 Immediately after the specification of the NuMAD job name, all pull-down menus are active and the job name is displayed in the title bar of the main window.

10.1.2 Selecting a System of Units

The system of units used for the new model may be set in the “Units” menu from the main menubar as indicated in Figure 10.4. The three systems available are SI (mks), foot-based English, and inch-based English. In Figure 10.4, the default current selection of mks units (indicated by the checkmark) need not be changed because the material properties for the model are know in SI units.

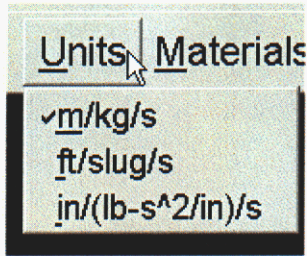

Figure 10.4 “Units” menu with SI (mks) units selected.

10.2 Airfoils

For each station in the model, an airfoil must be selected. When creating a new model, the NuMAD user must add any airfoil definitions needed for the model if these definitions are not already included in the airfoils database. For the model pseudoSERI8, nine stations are defined. The first two stations, corresponding to the blade root, are circular and the seven outboard stations are airfoils. The NuMAD airfoils database includes all of the airfoils listed in Table 10.1 with the exception of “trans1.” This is an arbitrary name given to a transitional airfoil between the S807 and the S805A/7. In this instance, only the “trans1” airfoil must be added to the airfoils database.

Table 10.1 Station data for the pseudoSERI8 model.

| Station # | Airfoil | Location (in) | Chord (in) | Twist (deg) |
|-----------|----------|---------------|------------|-------------|
| 1 | circular | 0.0 | 16.5 | - |
| 2 | circular | 18.0 | 18.5 | - |
| 3 | S808 | 60.0 | 44.0 | 20.0 |
| 4 | S807 | 88.6 | 43.0 | 15.7 |
| 5 | trans1 | 120.0 | 40.4 | 8.85 |
| 6 | S805/7 | 160.4 | 36.0 | 4.22 |
| 7 | S805A | 232.2 | 26.2 | 0.59 |
| 8 | S806A | 296.0 | 15.9 | 0.01 |
| 9 | S806A | 312.0 | 13.0 | 0.00 |

The coordinate pairs describing the airfoil “trans1” are shown in Figure 10.5. This is a simple text file in which each pair of coordinates is separated by a space or tab. The first pair is at the tail of the airfoil. The subsequent coordinate pairs move in a clockwise fashion along the lower surface then the nose then the upper surface. The final coordinate pair does not duplicate the first pair.

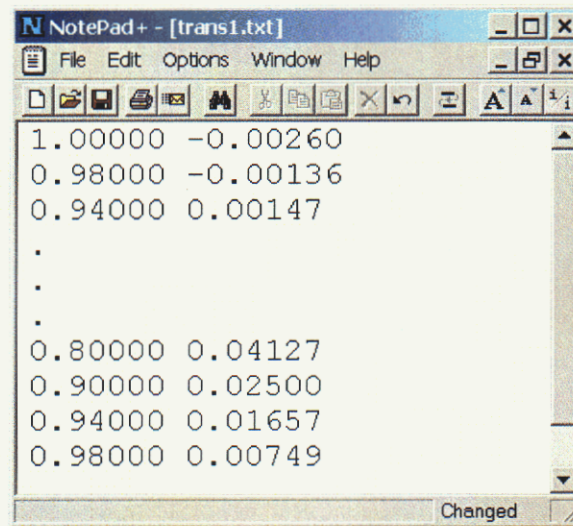

Figure 10.5 Coordinate pairs defining the transitional airfoil “trans1.”

A few tags must be added to the airfoil data to make it compatible with NuMAD. First, a reference block should be added. The reference block includes the tags `<reference>` and `</reference>` with any user-selected text in between. Tags bracketing the coordinate pairs should then be inserted as indicated in Figure 10.6. Though the filename need not change, in this example the filename has been changed to *trans1.32*. The file suffix indicates that the airfoil definition contains 32 coordinate pairs and implies that this file is not merely the original data, *trans1.txt*. The file *trans1.32* is then copied to the airfoils database in *NuMAD/Ncore/airfoils*. This airfoil is now available to NuMAD.

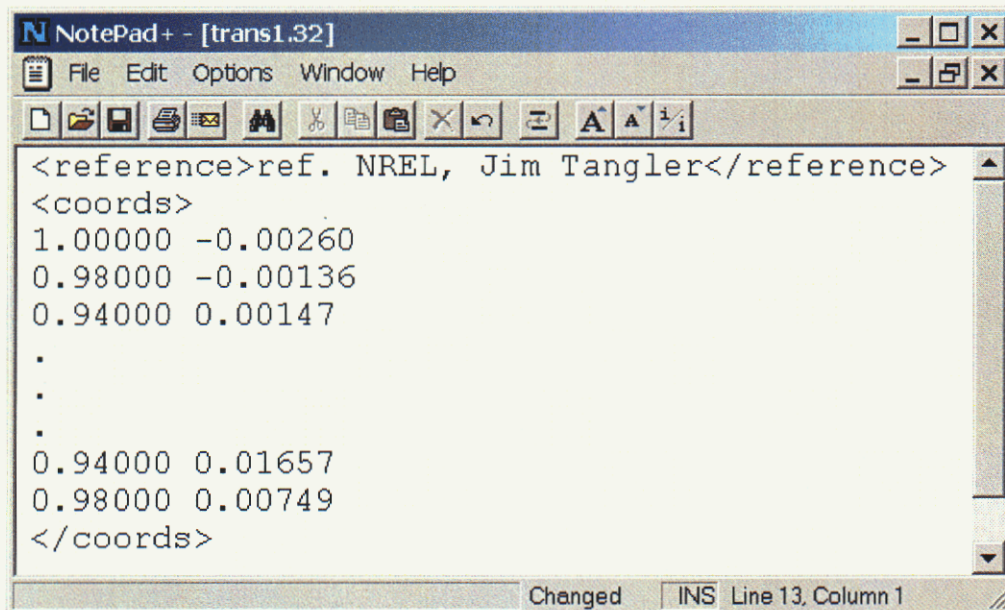

Figure 10.6 The “trans1” airfoil coordinate pairs transformed into NuMAD format.

10.3 Material Properties

The materials used in a blade model should be defined before the blade geometry is specified. While this is not strictly necessary, it is more efficient than defining the geometry, defining the materials, and then modifying the materials associated with the geometry. The user first defines the orthotropic materials which will be used in the model. These may be considered to be layer properties. Once the layer properties are defined, the user can then “build” composite materials by stacking the layer materials.

10.3.1 Layer Properties

The layer properties needed for the current example are shown in Table 10.2. These properties describe a complete layer in a composite stack. In other words, the combined properties of the fibers and matrix material are presented in Table 10.2. Thus even for a given fiber material and matrix material, the layer properties will vary depending on the fiber volume in the layer. For this reason, a typical NuMAD layer name might be D155fv36CoRezn63AX051. The name indicates the fiber material (or mat), D155, the fiber volume (36%), fv36, and the matrix material, CoRezn63AX051. For the current example, the simple names Mat (random mat), Triax, Uni, and Core are used. Of course, other blade models might require the definition of dozens of layer properties.

Table 10.2 Orthotropic material properties used in the model pseudoSERI8.

| Property | Mat | Triax | Uni | Core |
|-----------------------------|------|-------|------|-------|
| E_x (GPa) | 9.65 | 24.2 | 31.0 | 2.07 |
| E_y (GPa) | 9.65 | 8.97 | 7.59 | 2.07 |
| G_{xy} (GPa) | 3.86 | 4.97 | 3.52 | 0.14 |
| ν_{xy} | 0.30 | 0.39 | 0.31 | 0.22 |
| ν_f | | 0.40 | 0.40 | |
| ρ (g/cm ³) | 1.67 | 1.70 | 1.70 | 0.144 |

To display the materials database so that new orthotropic materials may be added, the “Materials” button from the main menubar should be selected (Figure 10.7). This action will produce two windows as shown in Figure 10.8. The first window, “Currently defined materials,” displays the isotropic, orthotropic, and composite materials present in the database. In this example, no user-defined materials have been added to the database, the only materials present are those included with the NuMAD installation. The second window, “Currently defined fibers and matrices”, displays fiber materials and matrix materials. These may be used to approximate layer materials by selecting a fiber, matrix, fiber volume, and a Halpin-Tsai constant. Together these two windows display the materials database and may be accessed regardless of whether a jobname has been defined.

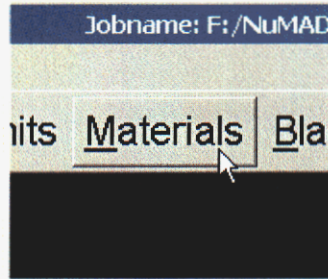

Figure 10.7 Selection of the “Materials” button from the main menu bar.

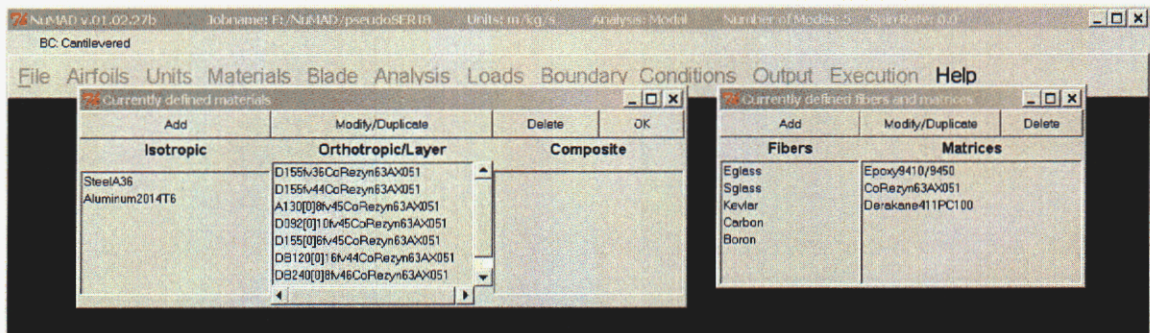

Figure 10.8 The materials database which appears after selection of the “Materials” button from the main menu bar.

The “Currently defined materials” window allows the user to add, delete, modify, or duplicate an isotropic, orthotropic, or composite material. For the current blade example, four new orthotropic (layer) materials need to be added to the database. To add an orthotropic material the “Add” button may be selected which produces a pull-down menu (Figure 10.9). From the pull-down menu, “Ortho/Layer” should be selected and then “Direct Definition” should be selected from the submenu. This action will cause the input window shown in Figure 10.10 to be displayed.

The first entry area in Figure 10.10 allows the user to specify a name for the new orthotropic material. Once the definition is complete, this is the name that will appear in the “Orthotropic/Layer” listbox in the “Currently defined materials” window

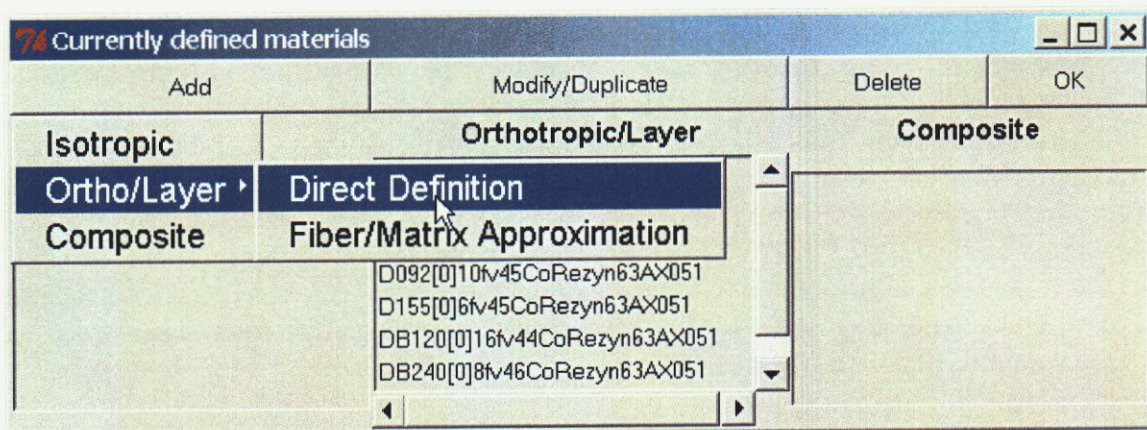

Figure 10.9 Menu path to add a new orthotropic material via direct definition of the material properties.

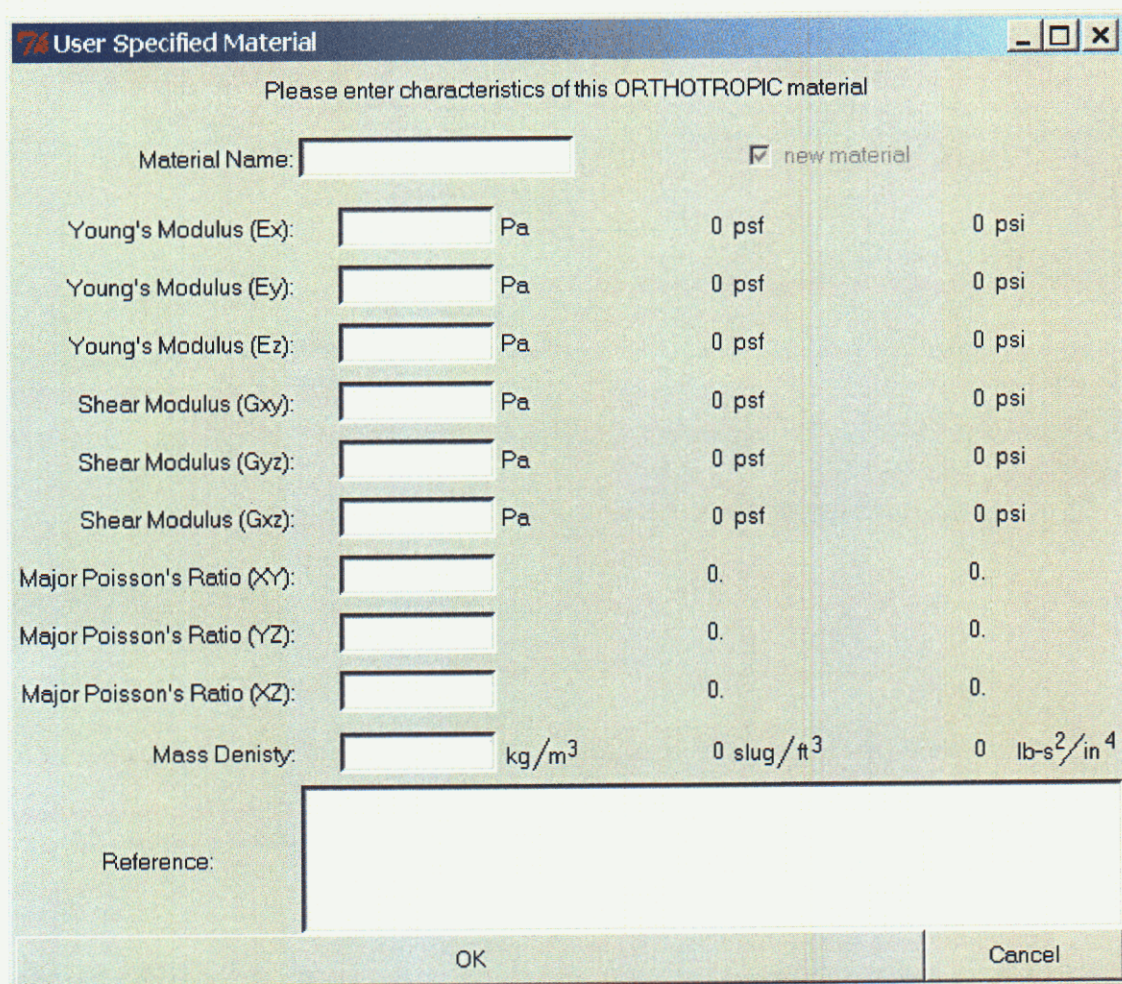

Figure 10.10 Input window to define a new orthotropic material by direct definition of properties.

in Figure 10.8. To the right of this entry box is an inactive checkbox indicating that this is a new material. The checkbox would be active if the user were modifying a material rather than adding a new material. Below the entry box for the material name are a number of label/entry pairs which allow the user to specify the properties defining this material. The units used for the input properties are the units currently defined in the Units menu (section 3.2.3). As the property values are entered, they are immediately converted and displayed in the two other standard systems of units present in NuMAD. The last entrybox allows the user to enter a reference and/or notes on the new material. This reference will be displayed as well as the properties when the material is highlighted in the materials database.

Figure 10.11 shows the completed input window for the new orthotropic material "Triax." The material properties entered are those listed in Table 10.2. Some assumptions were made to produce the full set of property values and these assumptions were listed in the reference area. The addition of the new material may be negated by selecting the "Cancel" button. Once the user selects "OK," the input window is removed and the new material name is added to the database.

User Specified Material

Please enter characteristics of this ORTHOTROPIC material

Material Name: new material

| | | | |
|-----------------------------|--|-----------------------------------|--|
| Young's Modulus (Ex): | <input type="text" value="2.420e+010"/> Pa | 505426680.0 psf | 3509919.6 psi |
| Young's Modulus (Ey): | <input type="text" value="8.970e+009"/> Pa | 187342038.0 psf | 1300990.86 psi |
| Young's Modulus (Ez): | <input type="text" value="8.970e+009"/> Pa | 187342038.0 psf | 1300990.86 psi |
| Shear Modulus (Gxy): | <input type="text" value="4.970e+009"/> Pa | 103800438.0 psf | 720838.86 psi |
| Shear Modulus (Gyz): | <input type="text" value="4.970e+009"/> Pa | 103800438.0 psf | 720838.86 psi |
| Shear Modulus (Gxz): | <input type="text" value="4.970e+009"/> Pa | 103800438.0 psf | 720838.86 psi |
| Major Poisson's Ratio (XY): | <input type="text" value="0.39"/> | 0.39 | 0.39 |
| Major Poisson's Ratio (YZ): | <input type="text" value="0.39"/> | 0.39 | 0.39 |
| Major Poisson's Ratio (XZ): | <input type="text" value="0.39"/> | 0.39 | 0.39 |
| Mass Density: | <input type="text" value="1700.00"/> kg/m ³ | 3.2985434016 slug/ft ³ | 0.000159072284298 lb-s ² /in ⁴ |

Reference:

OK Cancel

Figure 10.11 Completed input window for new orthotropic material "Triax."

Repeating the procedure outlined above, the other orthotropic materials needed for the model (Mat, Uni, Core) may be defined. These new materials become part of the materials database as indicated in Figure 10.12. When the cursor passes over any of the materials in the database, the definition of that material appears in a temporary window. In Figure 10.12 the properties of the orthotropic material “Uni” are displayed.

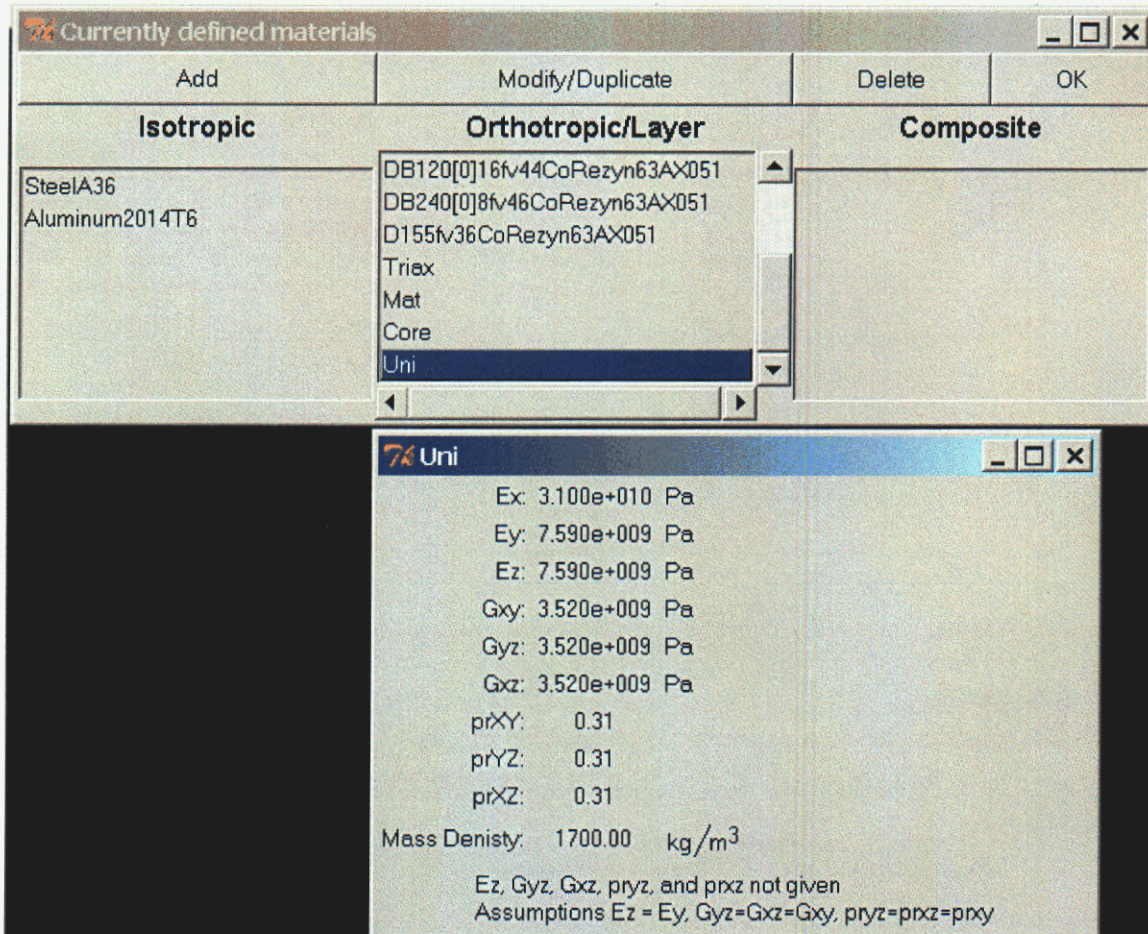

Figure 10.12 Materials database with new layers added. The highlighted material is “Uni” and its properties are displayed.

10.3.2 Composite Material Definitions

Composite materials are defined by selecting previously defined orthotropic materials to create a stack. To begin the definition of a new composite material, the “Composite” item may be selected from the “Add” pull-down menu as indicated in Figure 10.13. This action will cause the “Composite Material” input window (Figure 10.14) to be displayed. First, the name of the new composite material should be entered in the first entry box. Next, the type of symmetry used for the definition of the stack should be selected from the three radio buttons. The default is “Asymmetric” as indicated in Figure 10.14. A large entry box for notes and references is also supplied. For this example, the name of the new material is “root,” referring to the blade root, and the definition of the stack is begun by selecting the “Add New Layer” button as shown in Figure 10.15.

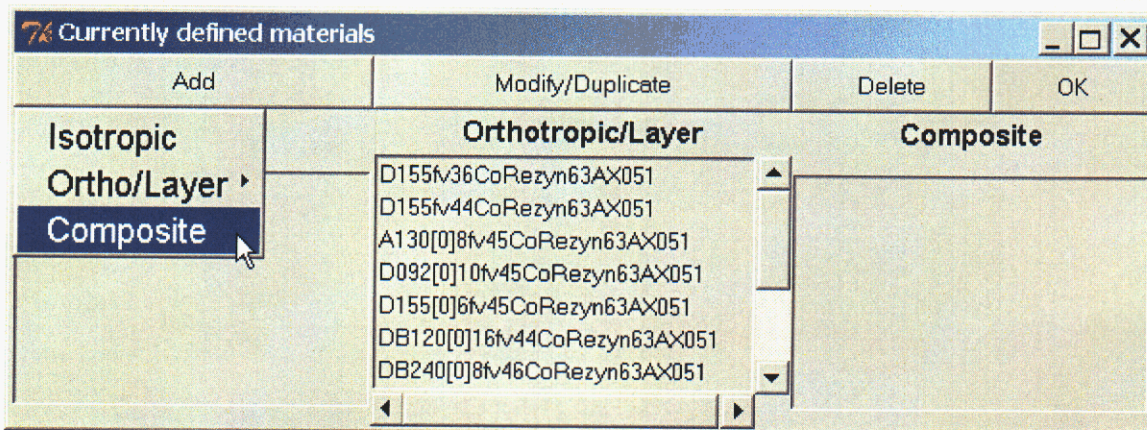

Figure 10.13 Menu path to add a new composite material.

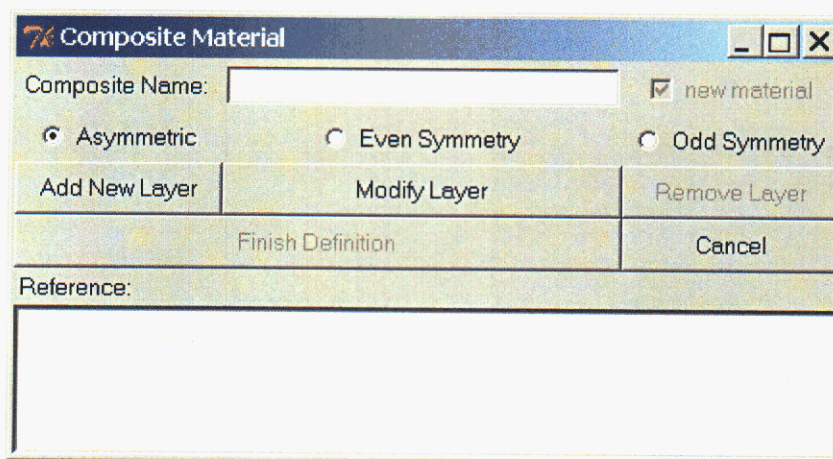

Figure 10.14 Input window for new composite material.

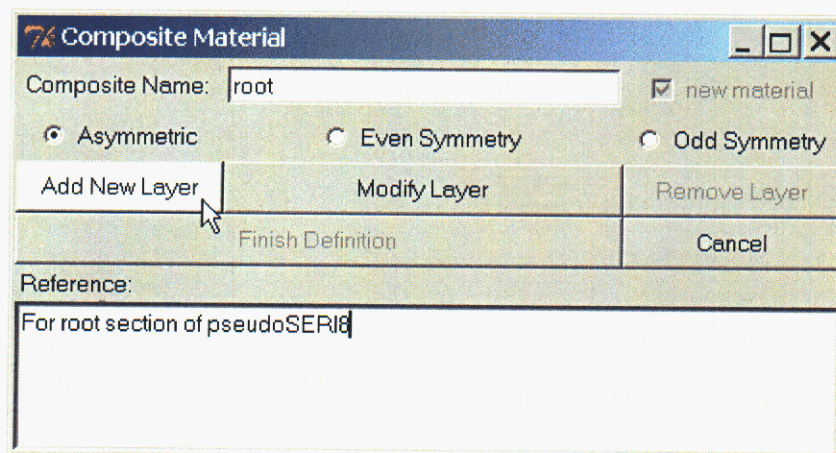

Figure 10.15 Selection of “Add New Layer” button from “Composite Material” window.

The input window used to add a new layer to the stack is shown in Figure 10.16. The material name and layer thickness are initially undefined while the layer orientation angle defaults to 90.0 degrees and the layer position defaults to the “top” of the stack. For the

first layer added, the layer position must be one because the total number of layers is only one.

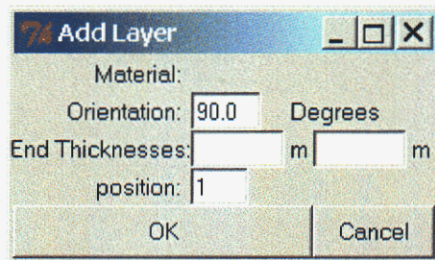

Figure 10.16 “Add Layer” input window for first layer of a new composite material.

The layer material is specified by selecting an isotropic or orthotropic (usual) material from the database as shown in Figure 10.17. The layer material is defined to be the “Mat” (random mat) orthotropic material. Once the name is selected from the database, that name appears in the “Add Layer” input window. The layer orientation for a random mat material is unimportant so the default value of 90.0 degrees is retained. The layer thickness is 0.0364” and the completed input window is shown in Figure 10.18.

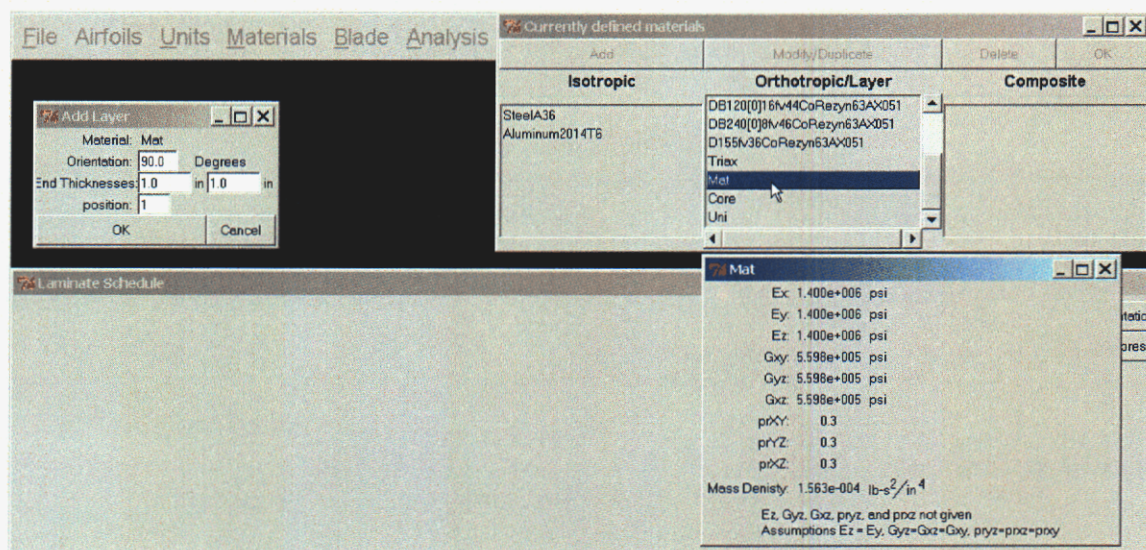

Figure 10.17 Selection of orthotropic material for the first layer of a new composite definition.

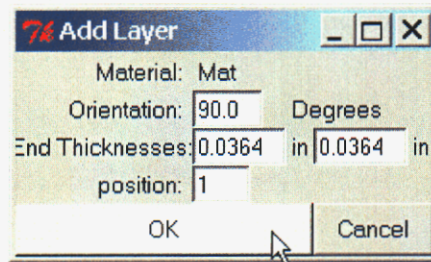

Figure 10.18 Specification of layer thickness in “Add Layer” window.

Once the layer has been defined, a laminate schedule schematic is presented as shown in Figure 10.19. After the definition of only one layer, the schematic is not tremendously interesting but it does display the layer number, thickness, orientation, and material name. By repeating the procedure used to define the first layer, a second layer is defined and Figure 10.20 shows the resulting schematic. Note that the orientation angle for layer 2 is still 90.0 degrees though this material aligns with the blade axis.

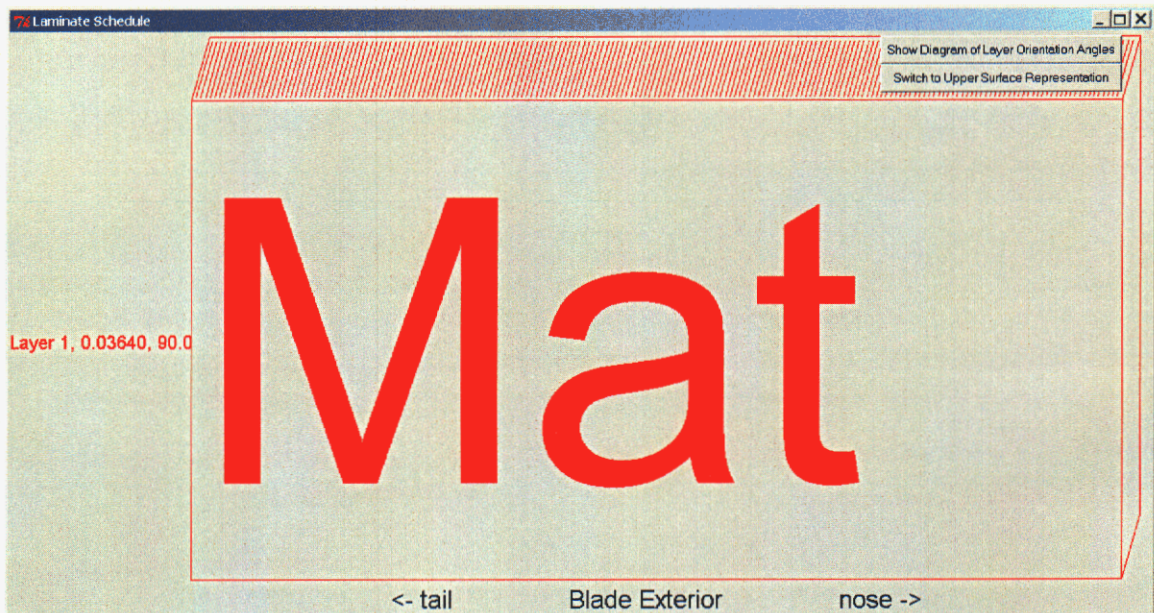

Figure 10.19 The laminate schedule after the definition of the first layer. The layer number, thickness, and fiber orientation are listed at the left.

NuMAD requires this strange definition for layer fiber orientation angles because of the finite element model which is later created in ANSYS®. The orientation of the layers is directly linked to the element coordinate systems of each shell element. A button in the upper right-hand corner of the laminate schedule schematic allows the NuMAD user to view a diagram of the layer orientation angles and this diagram is shown in Figure 10.21. As indicated, the sense of the orientation angles is different between the lower and upper surfaces of the blade. The only constants are that 90.0 degrees is along the blade axis and 0.0 degrees is perpendicular to the blade axis.

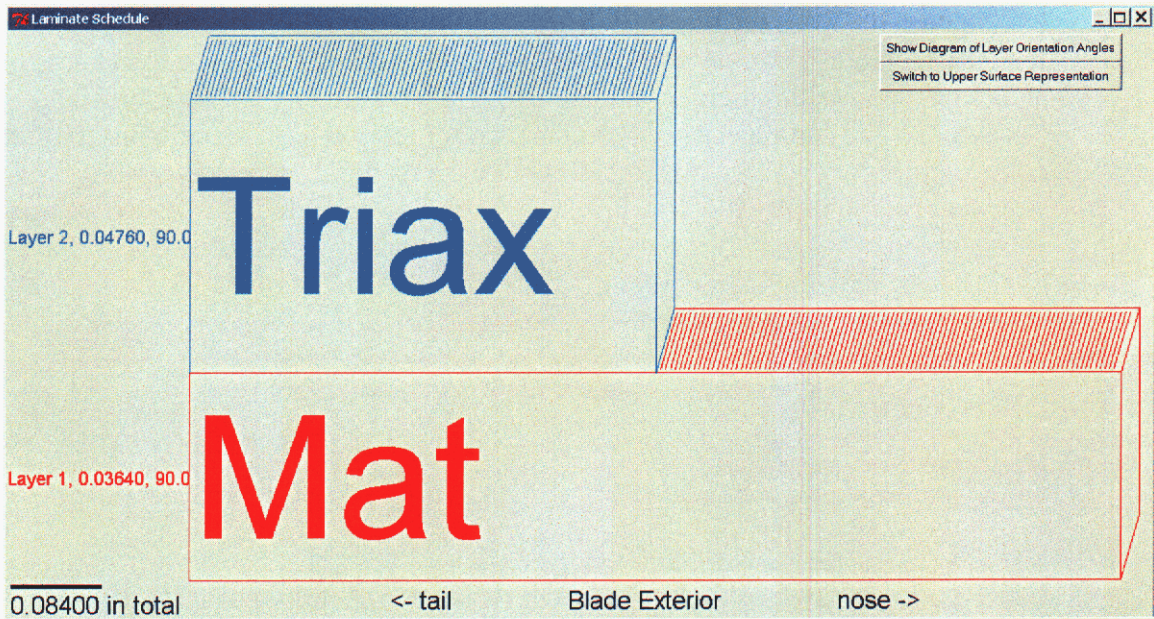

Figure 10.20 Laminate schedule after definition of the second layer. The name of each layer material is displayed and the total stack thickness is in the lower left.

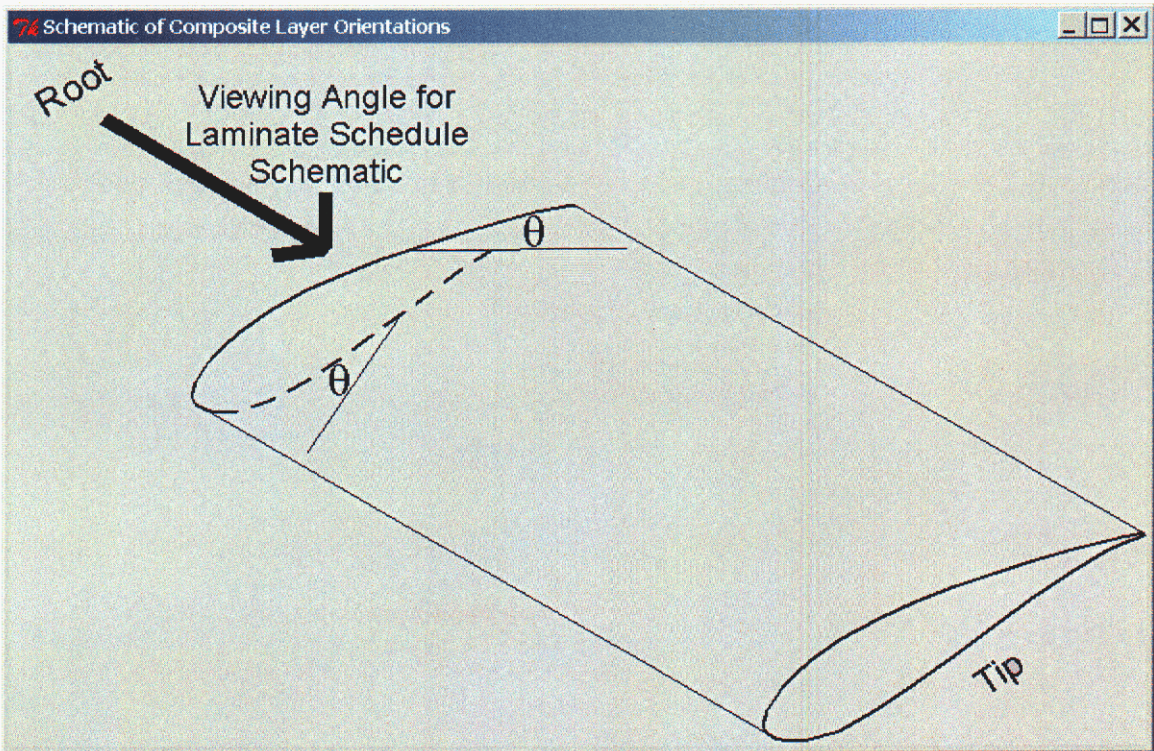

Figure 10.21 Schematic of the viewing angle employed for the laminate schedule display of composite materials

Figure 10.22 shows the laminate schedule schematic for the completed definition of the composite material “root.” A total of forty-six layers are defined with a total thickness of 1.7192 inches. Given the simplicity of this model, all layers are aligned with the blade axis, 90.0 degrees. The laminate schedule schematic for another skin material used in the model is shown in Figure 10.23. This stack represents a material used in the trailing edge of the model and contains only fourteen layers. The thick core material used may be seen at layer four and the total stack thickness is just under 1 inch.

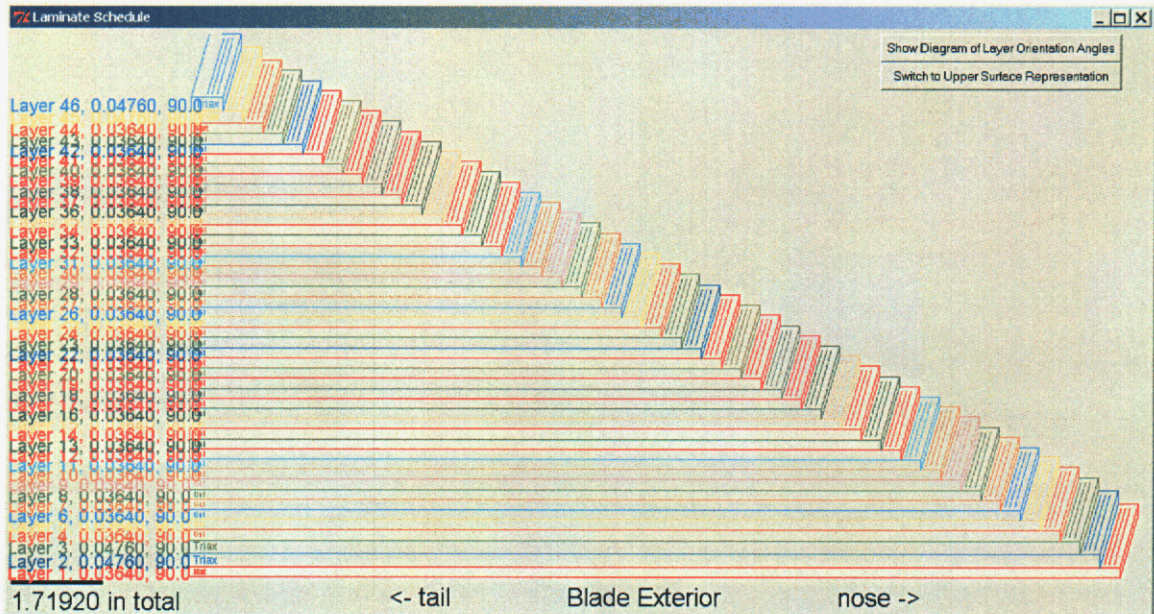

Figure 10.22 Completed laminate schedule for root material. Forty-six layers are defined.

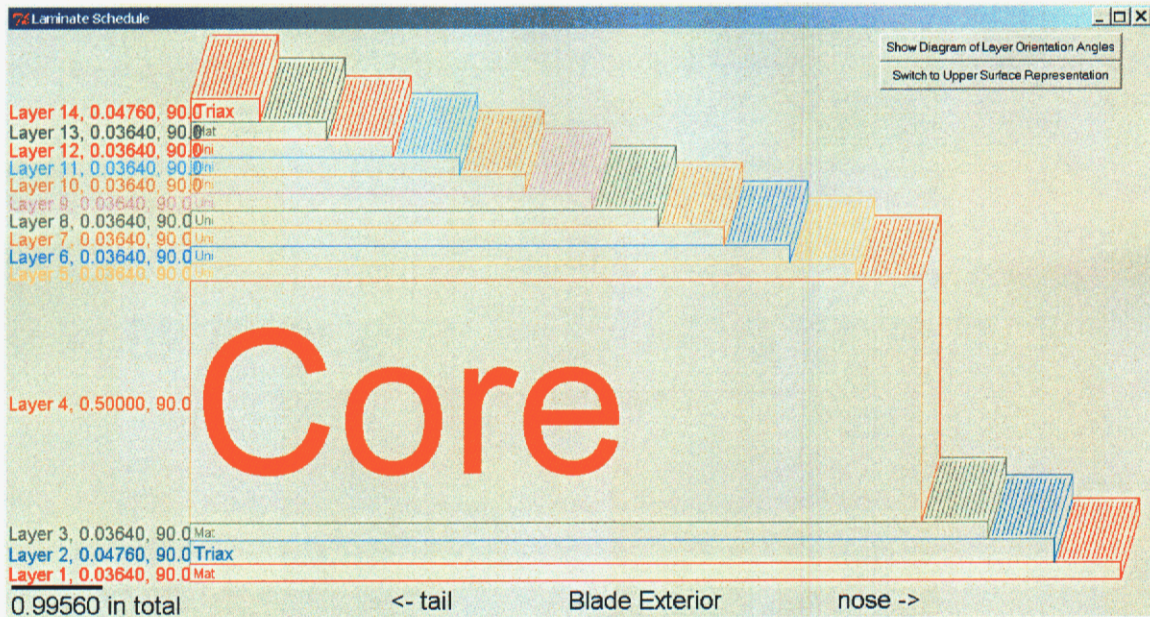

Figure 10.23 Completed laminate schedule for material used in the trailing edge.

By repeating this procedure, materials are defined for each portion of the blade model. A relatively large number of composite materials may be necessary because each time a ply is dropped, for instance, this is a new composite material as far as NuMAD/ANSYS® is concerned. For the current example, fourteen materials were defined to model the blade skin and three materials for the shear webs.

10.4 Blade Geometry

Once all of the necessary composite materials have been defined, the blade geometry may be specified. As shown in Figure 10.24, the process is begun by selecting the “Define” item from the “Blade” menu on the main menubar.

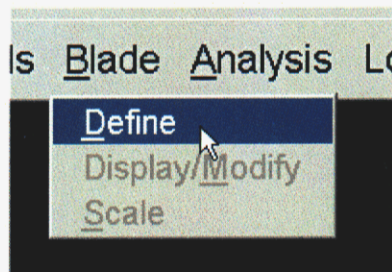

Figure 10.24 Selection of “Define” item from the Blade menu on the main menubar.

This action will cause the window shown in Figure 10.25 to be displayed. This window allows the user to select either manual or automatic skin geometry generation. In this example, manual skin geometry generation will be used. The user enters the total blade length in the first entry box and then selects the number of coordinate pairs to be used for all stations in the model. Though not obvious in Figure 10.25, the airfoils database is searched and an option menu created containing all of the unique numbers of coordinate

pairs from all airfoils in the database. This prevents the user from selecting a value which does not correspond to any airfoils in the database. In this example, airfoils defined by 32 coordinate pairs are used.

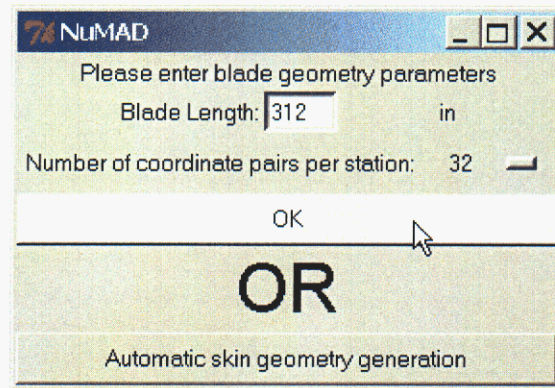

Figure 10.25 Selection of manual skin geometry generation. The total blade length and number of coordinate pairs per station are also specified through this window.

Once the "OK" button is selected (Figure 10.25), a simple two-station "blade" is displayed as shown in Figure 10.26. This is simply a starting point for the blade definition. A two-station blade is created by defining the first airfoil in the database at both stations with chord lengths of 10% of the blade length. The skin material defined at all locations is the first material in the composite materials database. From this starting point, stations are modified/added, shear webs are defined, and materials are assigned.

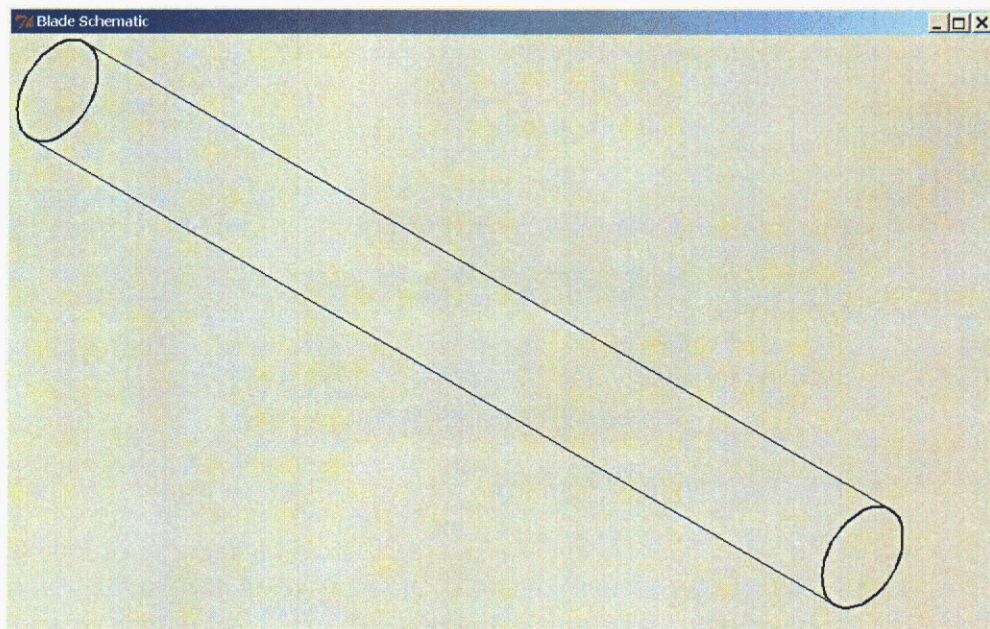

Figure 10.26 Initial "blade" schematic for manual blade skin geometry generation. The first profile in the airfoil database is used for the two stations.

The properties of an existing station may be displayed by simply moving the cursor over the station in the isometric blade schematic (Figure 10.27). The station profile will change from black to green and the profile will be displayed in a separate window above the window used for the blade schematic. At the left edge of the screen, two new windows will appear. The upper window, titled "Modify Station," displays the parameters defining the station. These include the station number, the airfoil, station twist, chord length, x-offset, number of element divisions in the axial direction, and the distance from the blade root. The second new window includes a list of all airfoils in the database defined by the selected number of coordinate pairs.

The values in Figure 10.27 are created by default as mentioned above. The airfoil, circular.32, is the first airfoil in the database (which contained 32 coordinate pairs). This choice of airfoil may be changed by selecting a different one from the list of airfoils in the window "Choose Airfoil." The entry box corresponding to the label "Twist of station:" is deactivated only because the selected station is circular and thus the twist has no meaning. If a different airfoil is selected, this entry box becomes active. The value for the chord length is 31.2 inches, this is simply 10% of the blade length. The x-offset value is 0.3 and both the element divisions and distance from root are deactivated. Both of these are deactivated because the selected station is station one. The first station is, by definition, at the blade root and may not be moved. The element divisions value always refers to the number of elements to create in the axial direction between the previous station and the current station. For the first station this has no meaning. The entire station is assigned the first material in the composites database, "root", which in this case is the correct material.

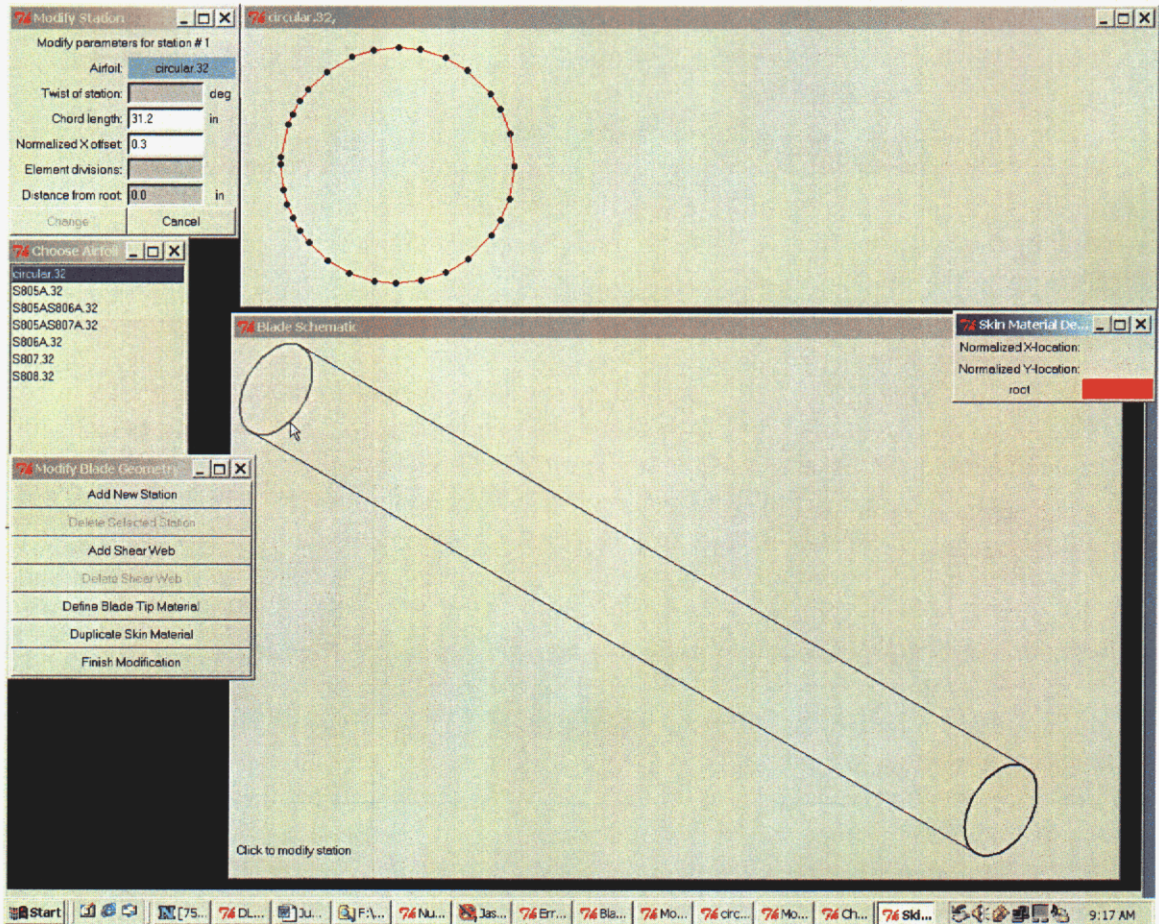

Figure 10.27 Station properties displayed as cursor crosses the first station in the blade schematic.

The changes necessary for the first station of the example problem are shown in Figure 10.28. The circular airfoil is correct and the chord length and x-offset are changed. The skin material, “root,” is also correct. When the “Change” button is selected, the blade schematic is updated and the windows containing the station parameters are withdrawn.

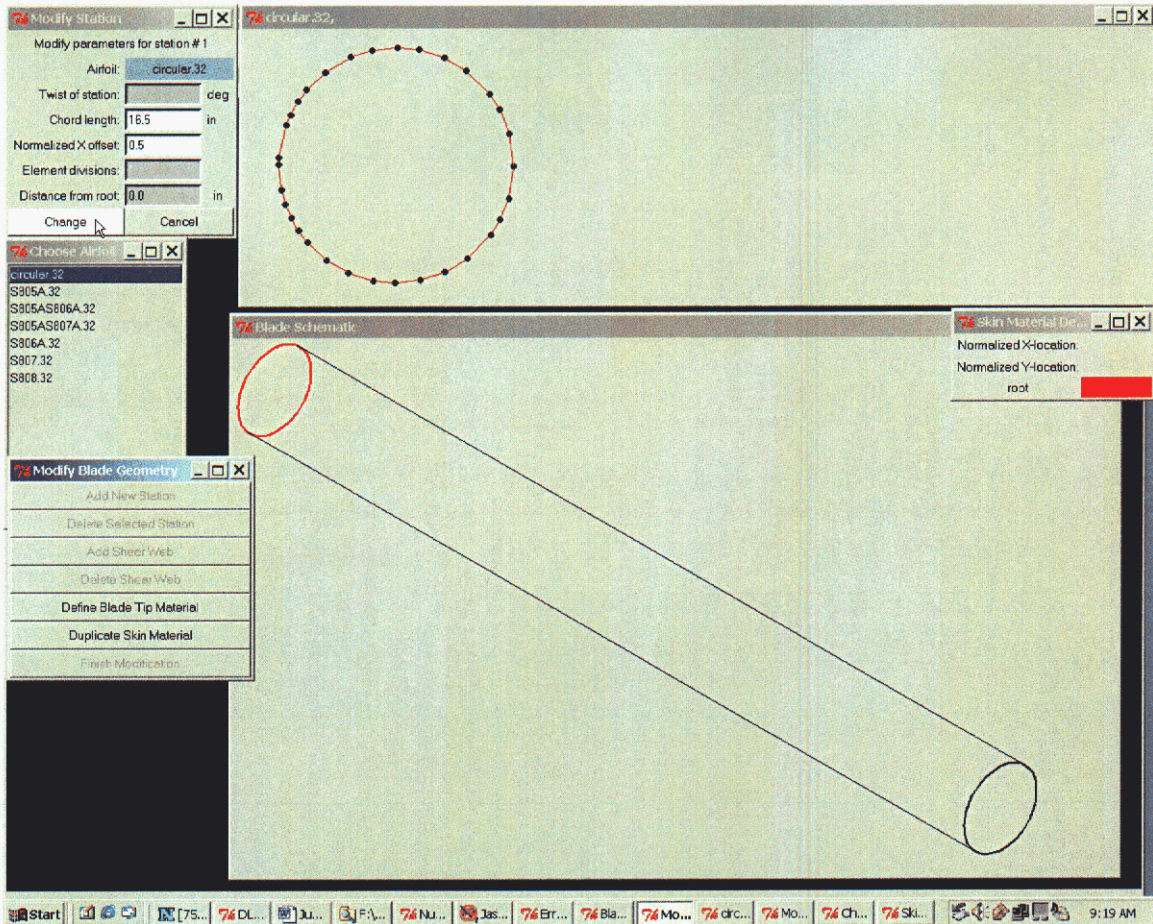

Figure 10.28 Modified properties for station number one.

The next step is to define station two, an interior station. First the “Add New Station” item is selected from the “Modify Blade Geometry” window (Figure 10.29). Next, the user selects the portion of the blade where the new station will be located (Figure 10.30). In this case, there are only two stations previously defined. Once the blade portion is selected, windows are displayed to allow the new station to be defined. This process is very similar to the process of modifying a station which was described for station one.

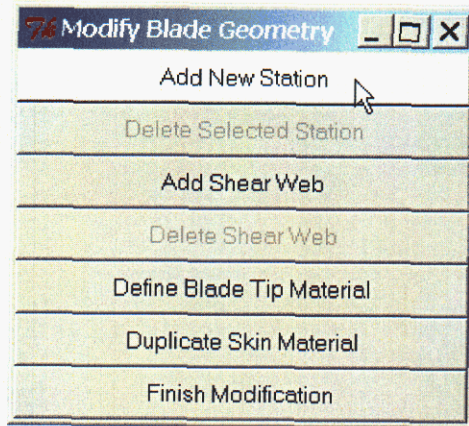

Figure 10.29 Selection of “Add New Station” from the “Modify Blade Geometry” menu.

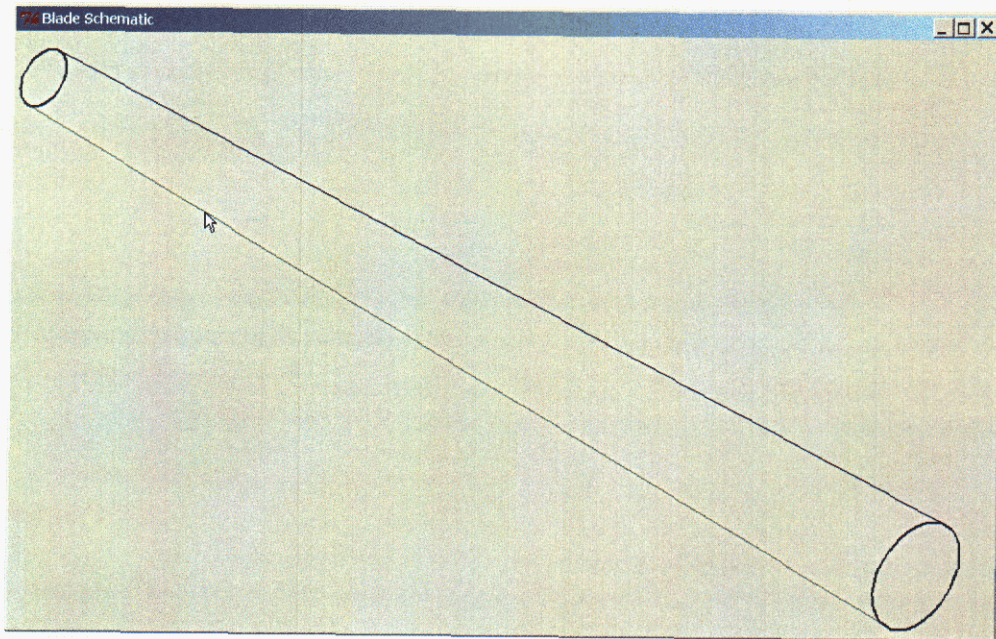

Figure 10.30 Selection of “blade” section to add a new station.

The values prescribed for station two are shown in Figure 10.31. The airfoil and material are unchanged from station one but the chord length, x-offset, element divisions, and distance from root must be specified. Once the values have been entered and the “OK” button selected, the blade schematic is updated (Figure 10.32).

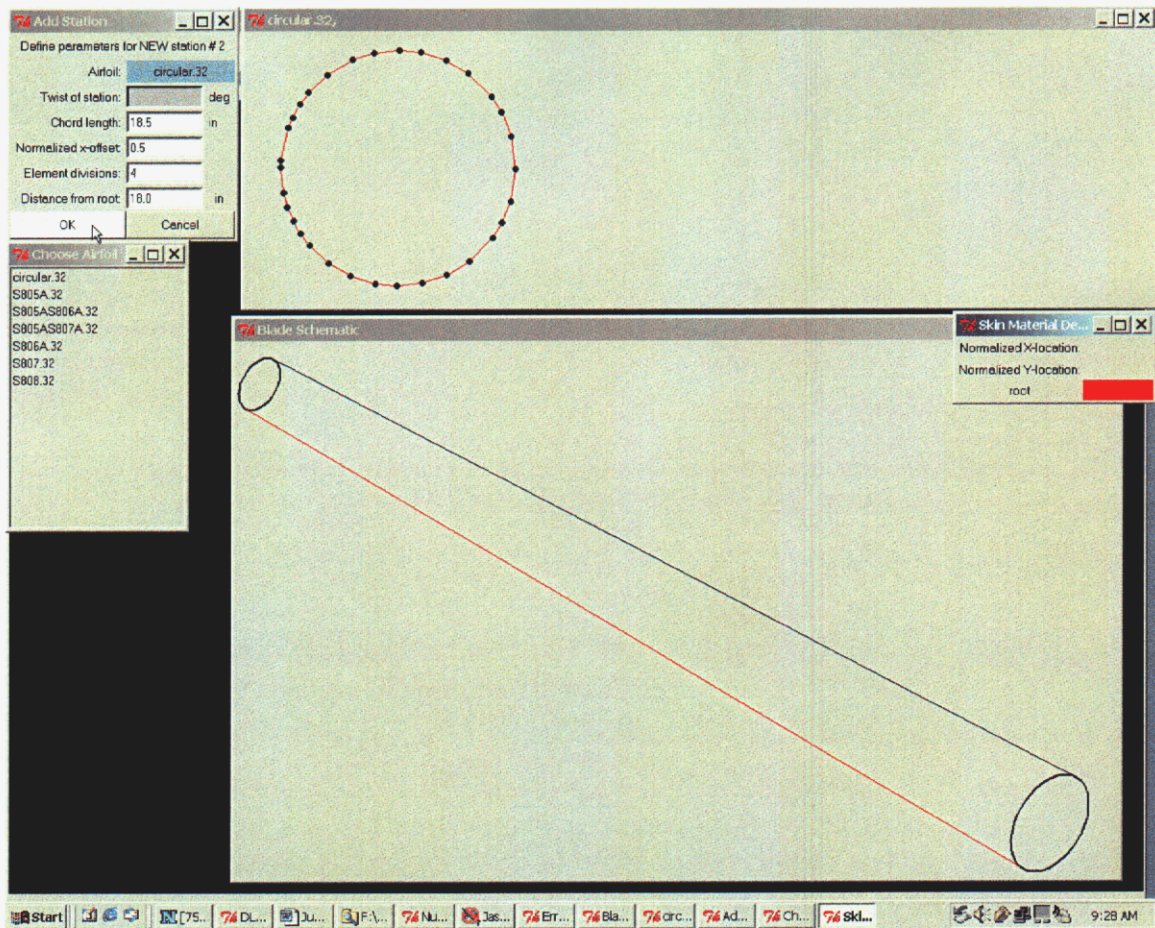

Figure 10.31 Properties for the second station. Still in the root portion of the blade, the “airfoil” is circular.

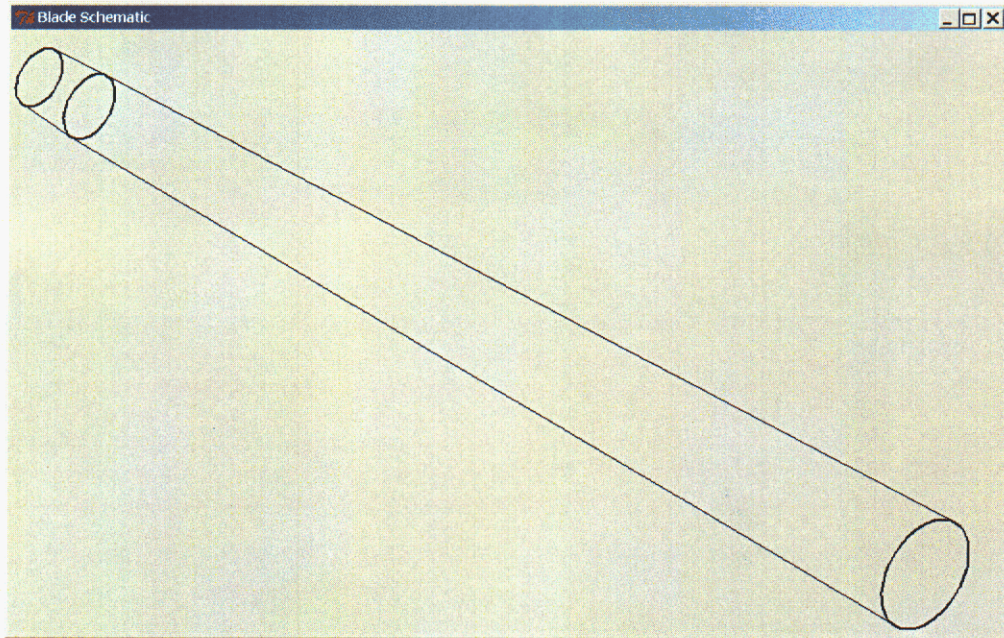

Figure 10.32 Blade schematic after addition of second station.

The first true airfoil is defined at station three. Figure 10.33 shows the values selected for station three including the S808.32 airfoil as well as the chord length etc. This station, unlike the previous two, requires some effort to correctly specify the skin materials. The airfoil profile may be divided into numerous material sections. This is accomplished by selecting coordinate pair locations (black dots) in the window displaying the airfoil profile. In Figure 10.33, the cursor is positioned over one of the dots on the lower surface of the airfoil, near the tail. When this dot is selected, the profile is divided into two sections, as indicated in Figure 10.34.

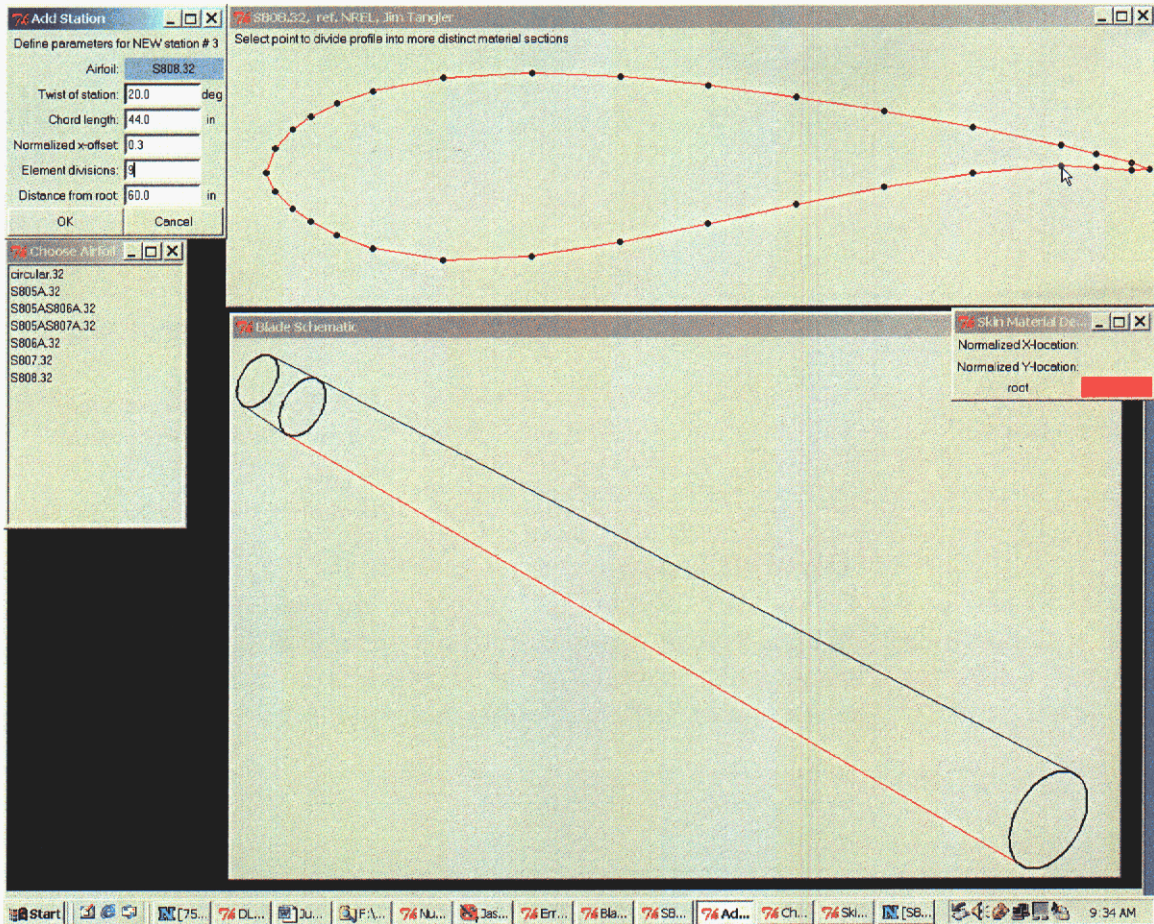

Figure 10.33 Addition of third station, the first station using a true airfoil.

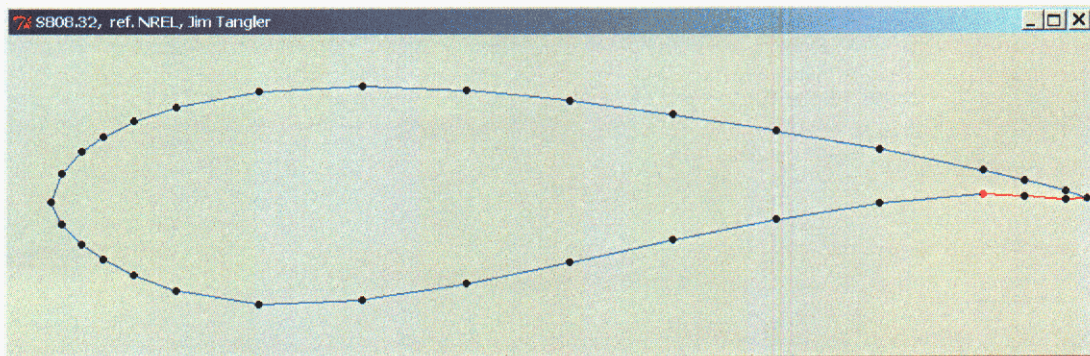

Figure 10.34 Definition of first material section (red) for the third station.

This process of selecting skin material break points may be repeated until the number of sections matches the number of actual materials comprising the profile. For the current example, Figure 10.35 shows the profile divided into seven skin material sections. These correspond to the material near the tail, the trailing edge material containing core material, the spar cap, and the nose. All but the nose are matching upper and lower surface material sections.

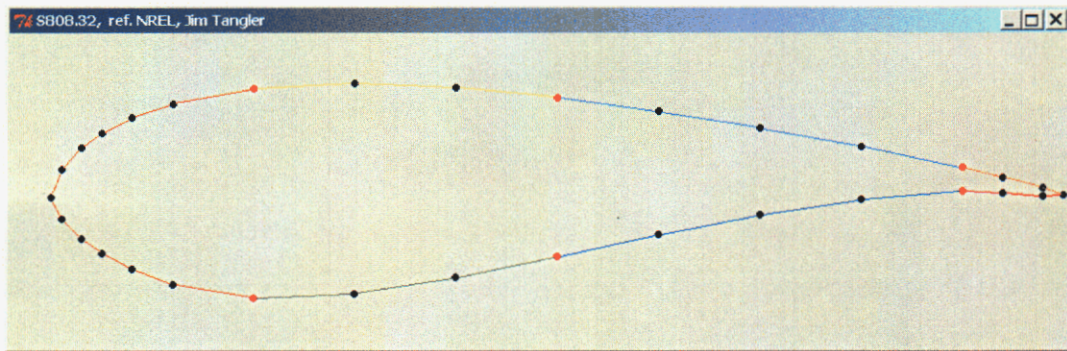

Figure 10.35 The third station (S808) divided into seven skin material sections.

Once the correct number of material sections has been obtained, the corresponding composite materials must be assigned. Figure 10.36 shows the third material section being specified. First, one of the line segments representing the third material section is selected. This causes the listbox containing the composite materials database to display. The user then selects the appropriate material from the listbox, in this case, SparCap1 (Figure 10.37). Once the composite material has been selected, the user again selects one of the line segments representing the material section to deactivate the material section.

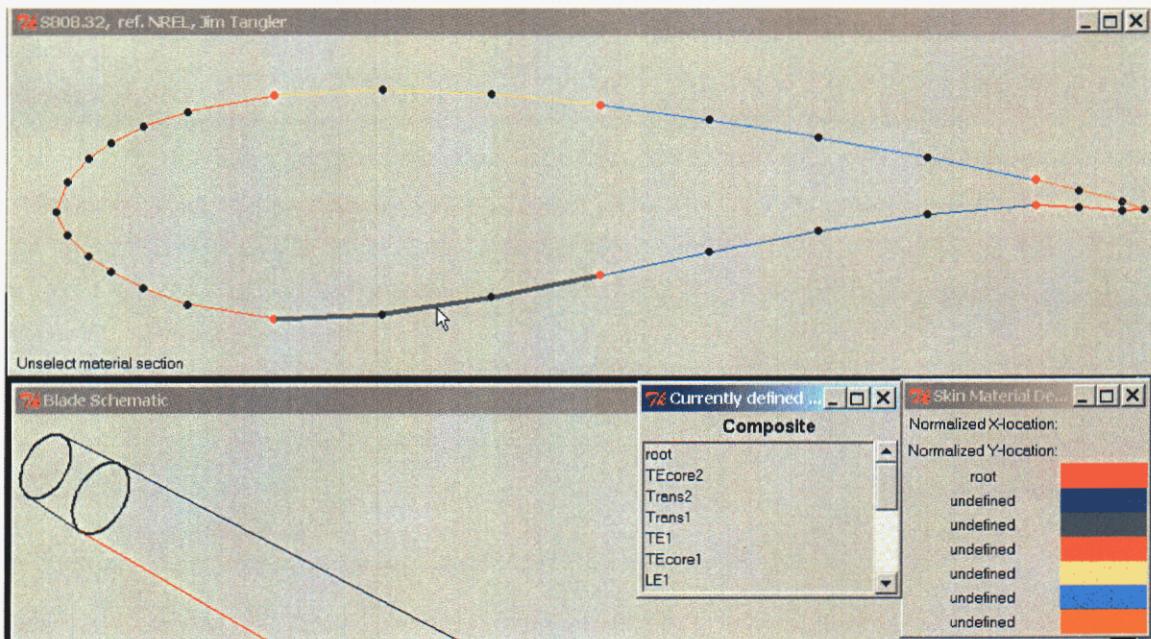

Figure 10.36 Selection of skin material section three for station three. Any previously defined composite material may be assigned to this material section.

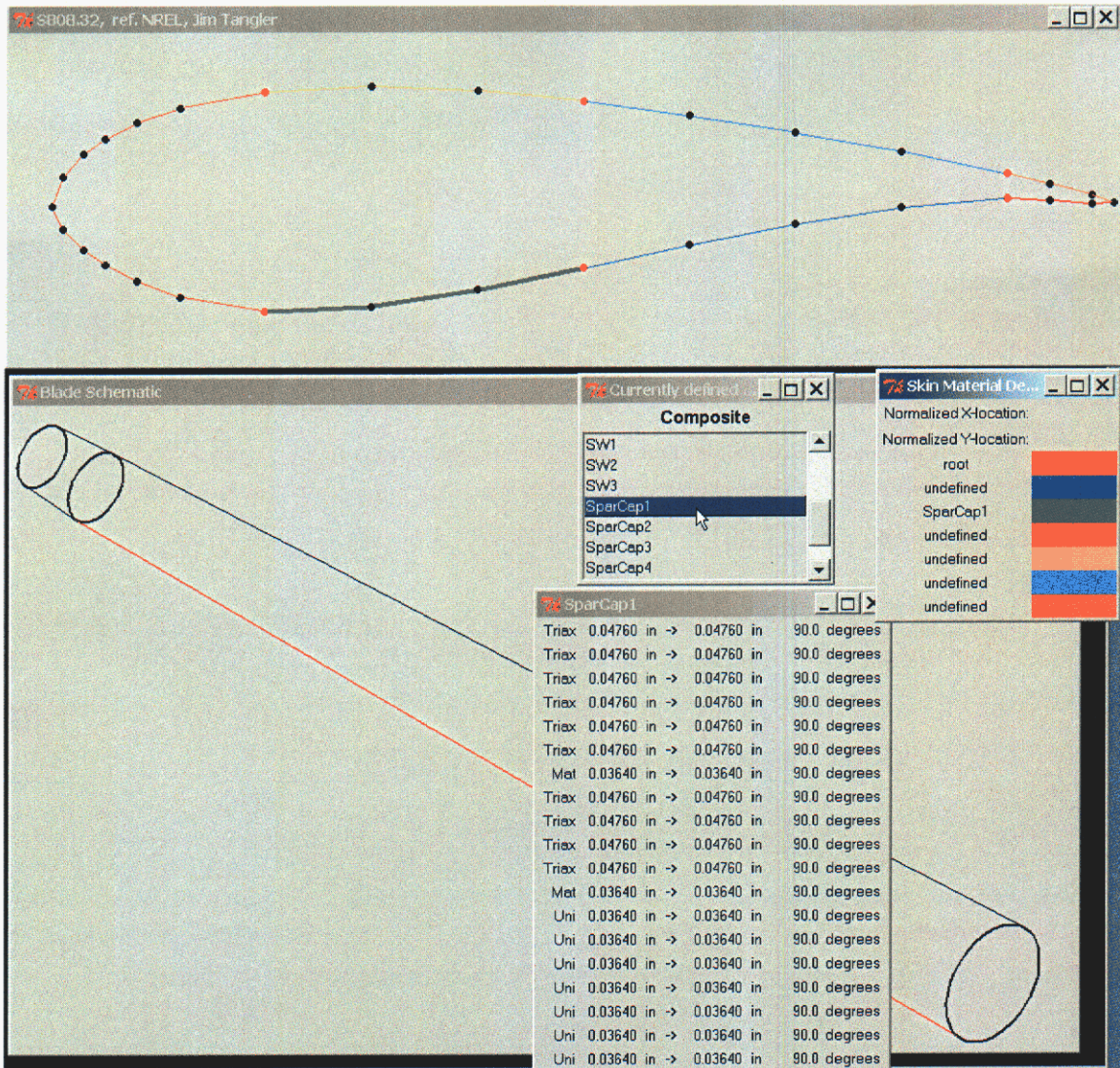

Figure 10.37 Selection of composite material “SparCap1” for skin material section three for station number three (S808).

This process must be repeated until all material sections have a corresponding composite material defined (Figure 10.38). If the user attempts to complete the addition of the new station without defining all material sections, a warning is posted and the user is directed to define the missing material section(s). Once station three is complete, the blade schematic is updated as shown in Figure 10.39.

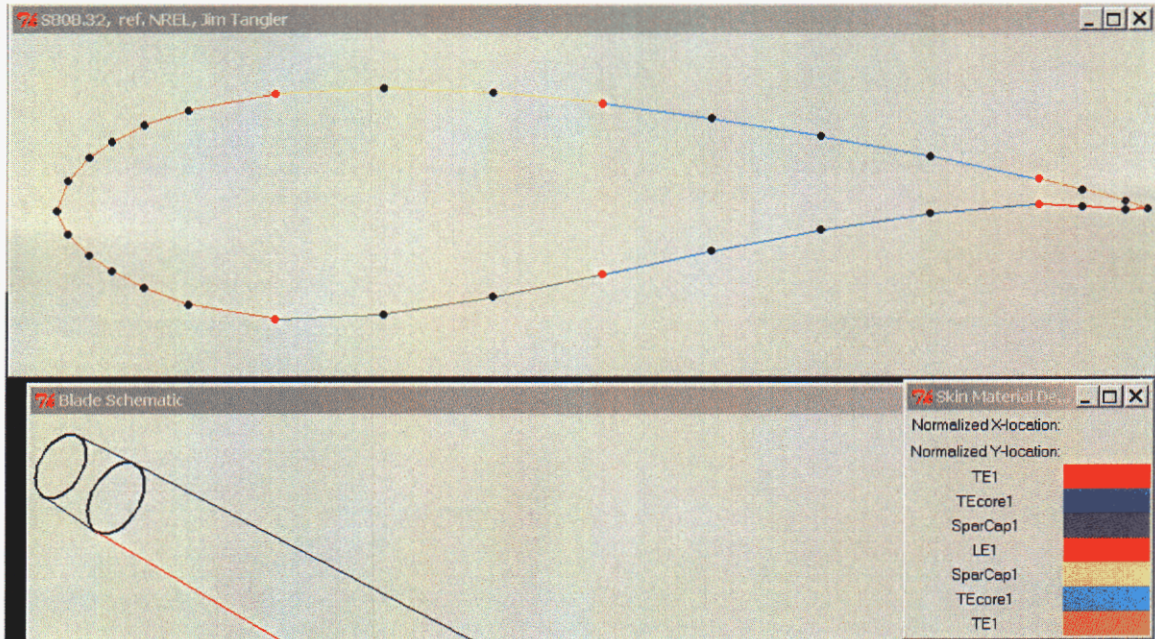

Figure 10.38 Completed skin material definitions for station number three.

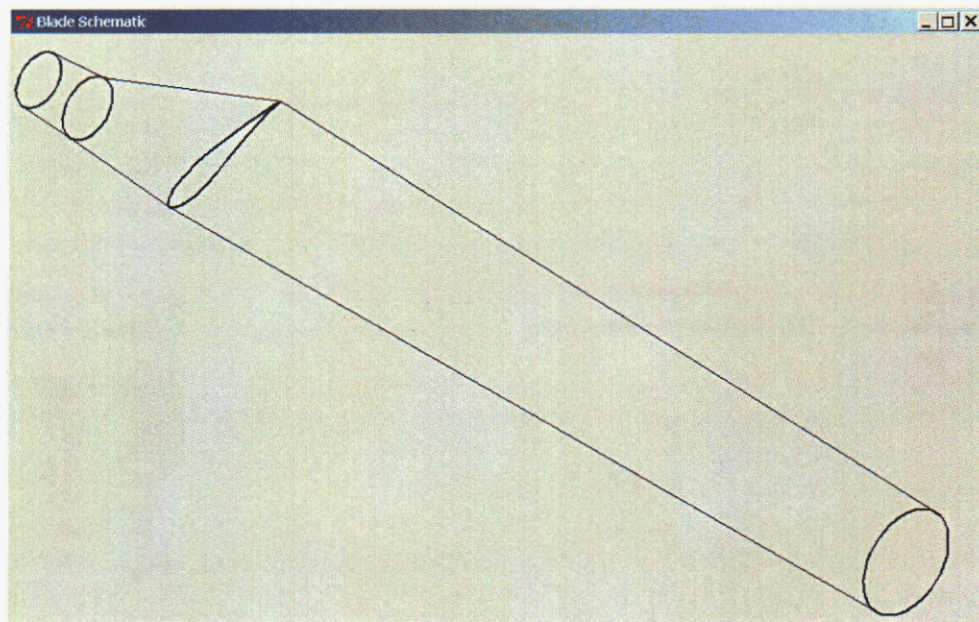

Figure 10.39 Blade schematic after definition of station number three has been completed.

The remaining stations are then defined. For each new station, the skin material definitions default to those defined for the previous station. Figure 10.40 shows the initial skin material definitions for station four. These definitions match those for station three but may be changed using the methods discussed previously.

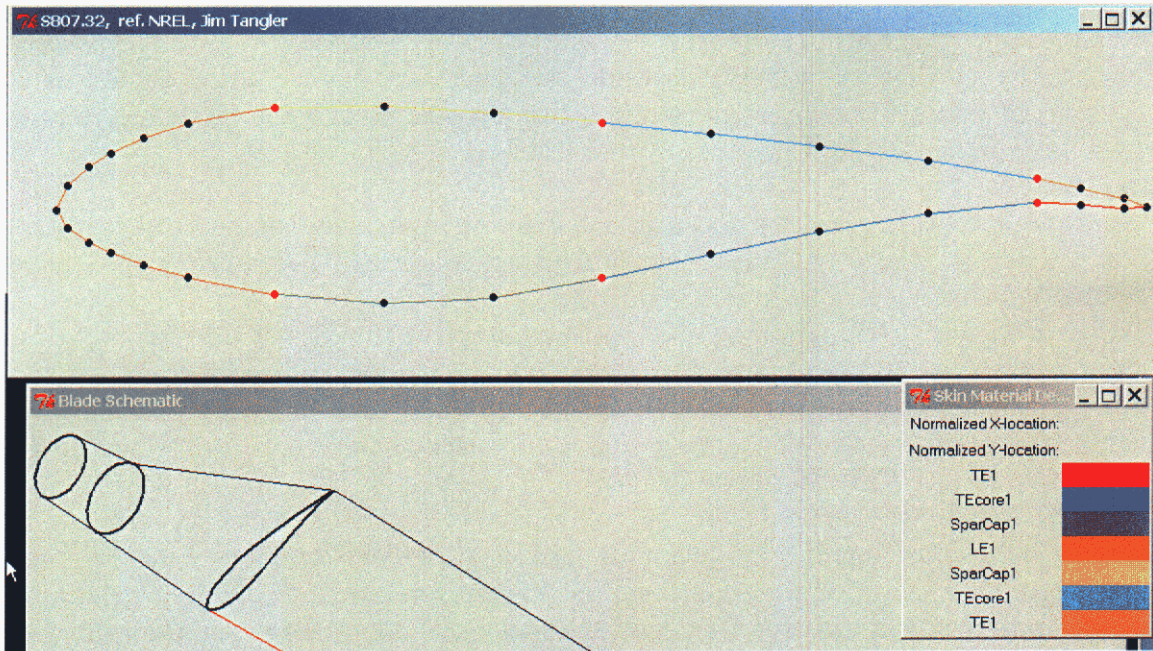

Figure 10.40 Initial skin material definitions for station four.

Once all stations are defined, the resulting blade schematic looks like the one shown in Figure 10.40. The definition of the blade exterior is now complete and the definition of shear webs may begin.

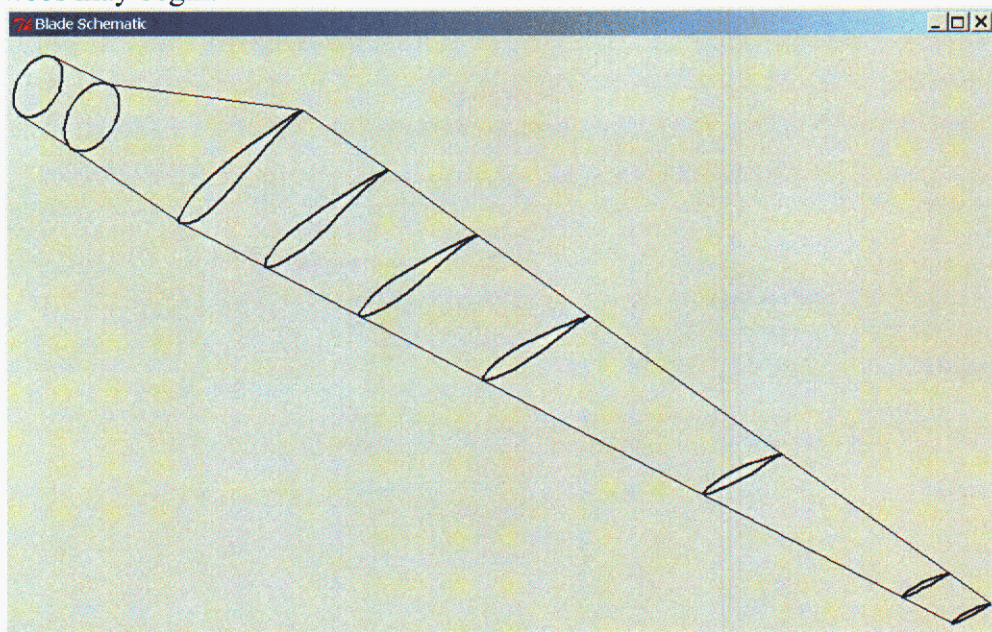

Figure 10.41 Final blade schematic representation after all stations have been added and modified.

10.4.1 Shear Webs

Shear webs may be defined by “drawing” the shear web on the airfoil profile of the appropriate station. In the current example, two physical shear webs are defined through specifying eight shear web segments within NuMAD.

Assuming the blade geometry and materials have been defined, creating a shear web is relatively easy. First the “Add Shear Web” item is selected from the “Modify Blade Geometry” window (Figure 10.42). This action causes the posting of the input window shown in Figure 10.43. The first line in this input window indicates that this is the first shear web to be added to the model. The next line allows the user to input a station number which bounds the shear web on the inboard side. Once this value (3 in this case) has been entered, the airfoil currently defined for station three appears (Figure 10.44). The following line (“End at station:”) allows the user to specify the station which bounds the shear web on the outboard side. The next input, “Number of elements:,” refers to the number of elements to be meshed through the shear web thickness, the “vertical” direction. The number of elements along the length of the shear web will be determined by the number of elements specified between stations. Finally, the material for the shear web is selected from the composite materials database listbox.

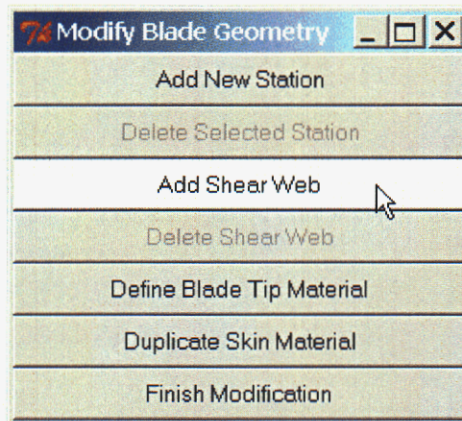

Figure 10.42 Selection of “Add Shear Web” from the “Modify Blade Geometry” menu.

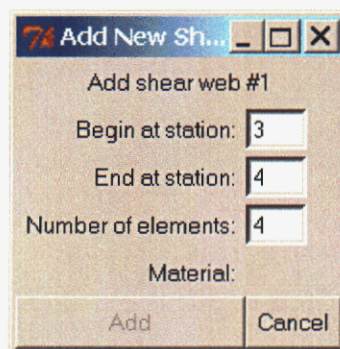

Figure 10.43 Input window to add a shear web. Once a begin-station has been specified, the corresponding airfoil profile is displayed.

Specifying the placement of the shear web within the station is done by “drawing” the shear web with the cursor. The first end of the shear web is selected at one of the coordinate pairs (black dots) defining the airfoil profile. A shear web is then drawn dynamically to follow the cursor until another coordinate pair is selected. This second selection becomes the second end of the shear web. In Figure 10.44, the first end has been selected and the shear web is following the cursor. After the shear web is defined, the blade schematic is updated as shown in Figure 10.45.

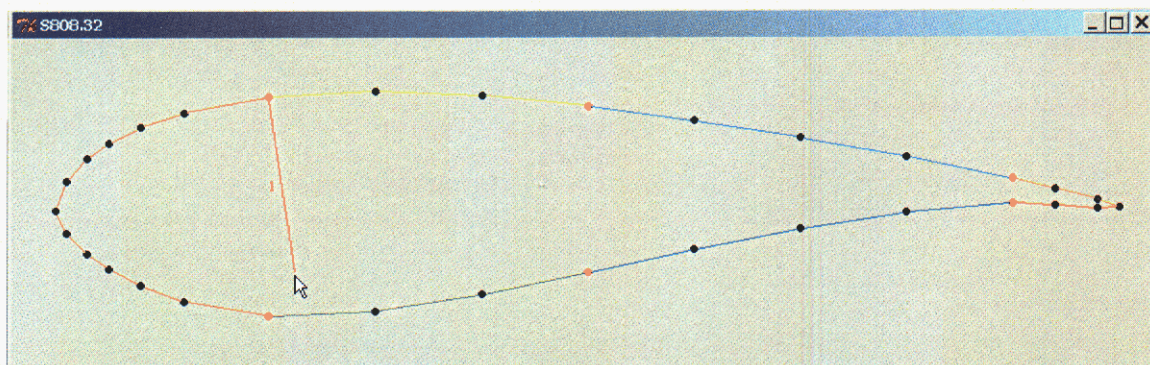

Figure 10.44 Specification of shear web number one. The endpoints must be coordinates defining the airfoil.

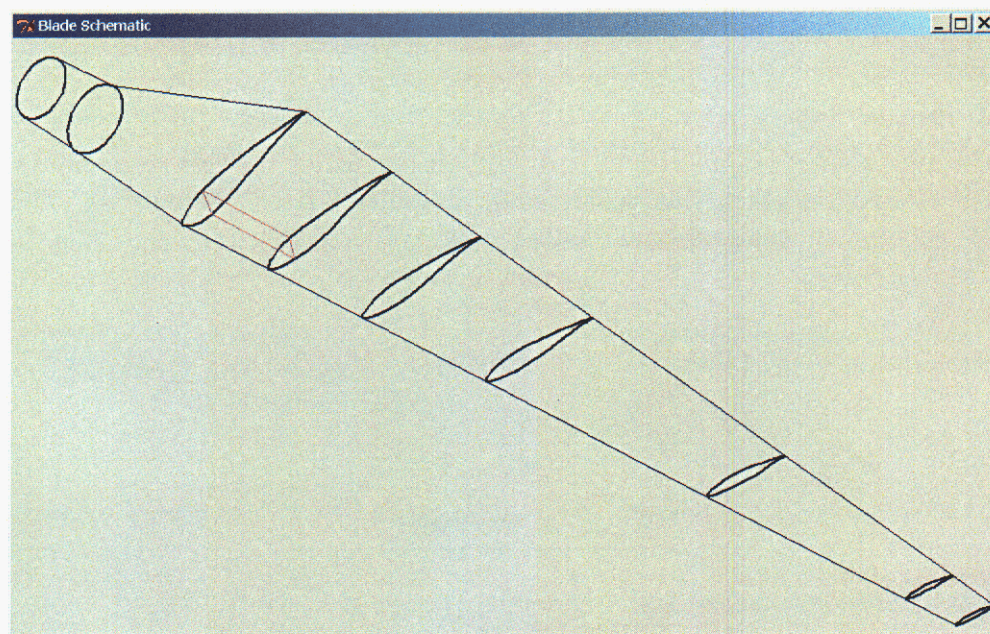

Figure 10.45 Blade schematic after definition of first shear web.

This process of adding shear webs is repeated until the two physical shear webs have been modeled. Due to the fact that the materials used for the two physical shear webs taper (change), the physical shear webs may not be modeled with just two shear webs within NuMAD. Instead the physical shear webs are divided into four segments which create a total of eight shear web segments within NuMAD. This allows a different

material to be associated with each shear web segment, thus allowing the tapering physical shear web materials to be modeled. The final blade schematic including the eight shear webs is visible in Figure 10.46.

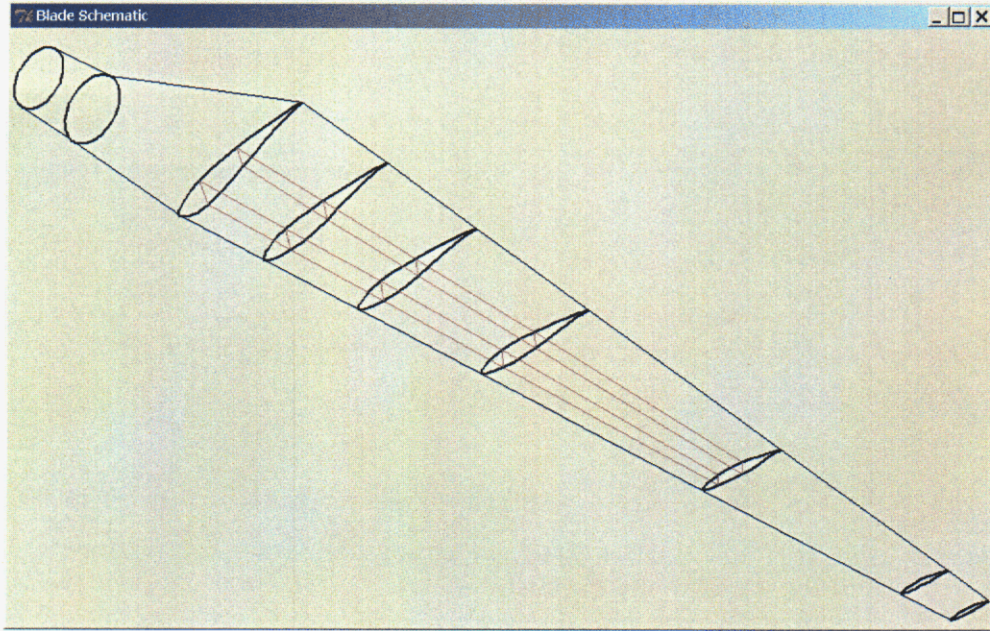

Figure 10.46 Blade schematic after all shear webs have been defined.

10.4.2 Blade Tip

Finally, a composite material must be specified for the blade tip. This is accomplished by selecting “Define Blade Tip Material” from the “Modify Blade Geometry” and then selecting a composite material from the listbox which is displayed.

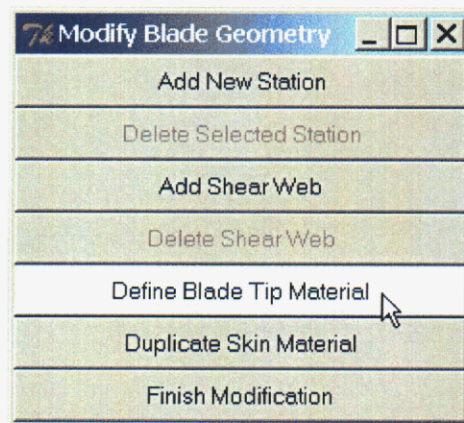

Figure 10.47 Selection of “Define Blade Tip Material” from the “Modify Blade Geometry” menu.

10.5 Analysis Type, Loadings, Boundary Conditions

The types of analyses to be performed are selected through the “Analysis” pull-down menu from the main menubar. The items in the menu are of a checkbox type so that each may be independently turned on or off. As shown in Figure 10.48, the current example uses all analysis types.

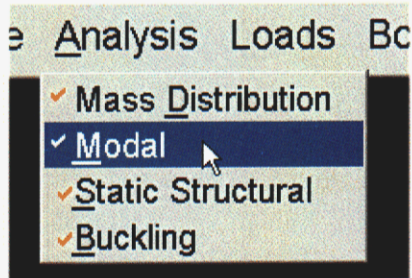

Figure 10.48 Analysis pull-down menu with all analyses selected.

The loads pull-down menu (Figure 10.49) is used to specify the values of the various loadings on the model. Specifying the number of modes to extract and the blade spin rate are very easy. Each is a matter of entering a value into a single entry box. For this example, eight modes were requested and a blade spin rate of 60 rpm specified.

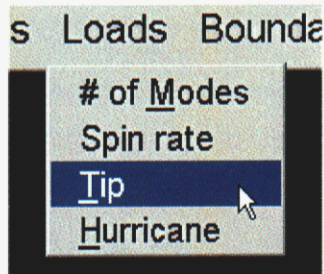

Figure 10.49 Loads pull-down menu with Tip load selected.

The input window for defining a concentrated tip load is shown in Figure 10.50. Loads may be specified in both the plan direction or edge direction. Multiple loadings of various values may also be specified though in this example only one tip load is prescribed. A pair of radio buttons also allow the user to select the use of the ANSYS® non-linear geometry option. The non-linear geometry option requires more computation time but should yield more accurate solution for large deflection analyses. In this example, the non-linear geometry option is not needed.

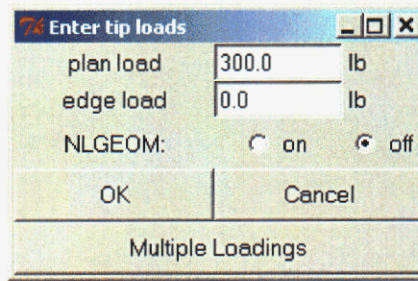

Figure 10.50 Input window used to specify concentrated tip loads.

The input window for defining a distributed pressure load on the high pressure surface of the blade is shown in Figure 10.51. The pressure is determined from a combination of wind speed, hub height elevation, and temperature. This approach is used to simplify the process of determining a pressure load due to extreme cases such as a hurricane. For arbitrary pressure loads a dummy wind speed may be specified. As with the concentrated tip load discussed previously, the ANSYS® non-linear geometry option may be selected.

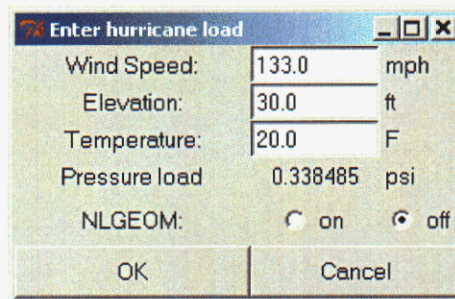

Figure 10.51 Input window used to specify distributed pressure loads.

The boundary conditions used for the NuMAD/ANSYS® analyses are generally fixed at the root end of the blade (cantilevered). Three translational degrees of freedom and three rotational degrees of freedom are constrained to zero for each node at the blade root. For modal analyses, free-free boundary conditions may be selected through the “Boundary_Conditions” pull-down menu shown in Figure 10.52.

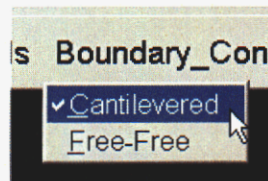

Figure 10.52 Boundary Conditions pull-down menu with cantilevered conditions selected.

10.6 Graphical Output

For the current example, only the JPEG format is desired and the specification of this format is shown in Figure 10.53. For the rasterized formats, TIFF and JPEG, three different resolution options are available. In the current example, the lowest JPEG

resolution, 800 pixels by 600 pixels, is selected. The resolution setting is independent of whether or not that file format has been selected. In Figure 10.53, no TIFF images will be created because there is no checkmark next to “TIFF.”



Figure 10.53 Graphical file format output pull-down menu with JPEG format selected.

10.7 ANSYS Launch

Once all parameters defining the model and analysis have been specified, the analysis may be performed. The analysis may be started immediately by selecting “Launch Now” from the “Execution” menu as shown in Figure 10.54.

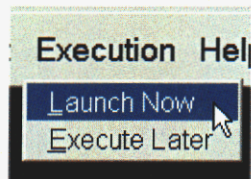

Figure 10.54 Analysis execution pull-down menu with immediate launch selected.

This action causes the main NuMAD window to be withdrawn and the ANSYS® batch analysis is begun. On most systems a blank system window will appear with a title such as “C:\WINNT\system32\cmd.exe.” This window may be minimized but should not be closed.

Depending on the size of the model, the number of analyses to be performed, and the particular machine being used, the analysis may take only a few minutes or it may take hours or days. When the “C:\WINNT\system32\cmd.exe” window disappears, the analysis is completed.

10.8 Results

The various results from the analyses are placed in the pseudoSERI8 directory. The contents of this directory are shown in Figure 10.55. Following is a description of the files and folders created by the analyses.

The file *file.log* simply records the ANSYS® revision number and the time and date that the analysis was launched.

The first file that should be investigated by the NuMAD/ANSYS® user after a solution is *file.err*. This file is generated by ANSYS® and it contains a list of all warnings and errors produced by ANSYS® during the various analyses performed. The user may then decide if the warnings are acceptable or if the model must be modified and resolved.

A complete listing of all of the ANSYS® responses to the input is recorded in the file *output.txt*. This file is usually quite long because it records the creation of every area, line, node, element etc. All warnings and errors in *file.err* are present in *output.txt*.

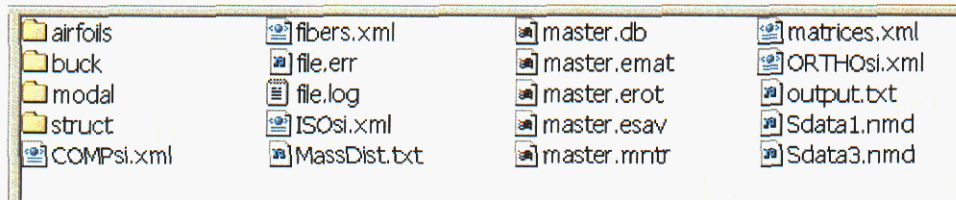

Figure 10.55 Contents of jobname directory after completion of analysis for pseudoSERI8.

The files *master.** are binary files created by ANSYS® which contain the database for the analyses. These files may be accessed through ANSYS® to verify the blade geometry or make more detailed modifications to the model.

MassDist.txt is a text file containing a tabular listing of the mass distribution of the blade. The first column contains the actual mass values and the second and third columns give a range of locations from the blade root for each mass value.

The other files present in the pseudoSERI8 directory existed before the analyses were performed.

The first new subfolder in pseudoSERI8 is named *buck*. This refers to the eigenbuckling analysis and this folder (directory) contains all of the ANSYS® files related to this analysis. A further subdirectory exists, *pseudoSERI8/buck/jpg*, which contains a jpeg image of the first buckling mode.

Another new subfolder in pseudoSERI8 is *struct*. This directory contains all of the ANSYS® files graphical output for both the tip load analyses as well as the distributed pressure loading (hurricane load) analyses. Figure 10.56 shows the contents of *pseudoSERI8/struct/tipload*. The files *tip.** may be accessed by ANSYS® to further modify the model or extract additional output. A subdirectory named *jpg* is also created for the default graphical output. This matches the selection shown in Figure 10.53. Had postscript and TIFF formats been selected as well as JPEG, two additional subdirectories would be present at this point (*ps*, *tif*).

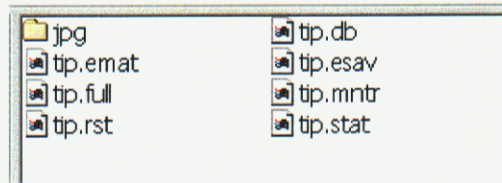

Figure 10.56 Contents of subfolder (directory) pseudoSERI8/struct/tipload.

Numerous images are created automatically and placed in the *jpg* folder as indicated by the partial list shown in Figure 10.57. The first file, *displace.jpg*, shows the deformed shape of the blade due to the concentrated tip load. This image is shown in Figure 10.58. The contours indicate the flapwise displacement. For this example, the tip displacement is about 4.5 inches.

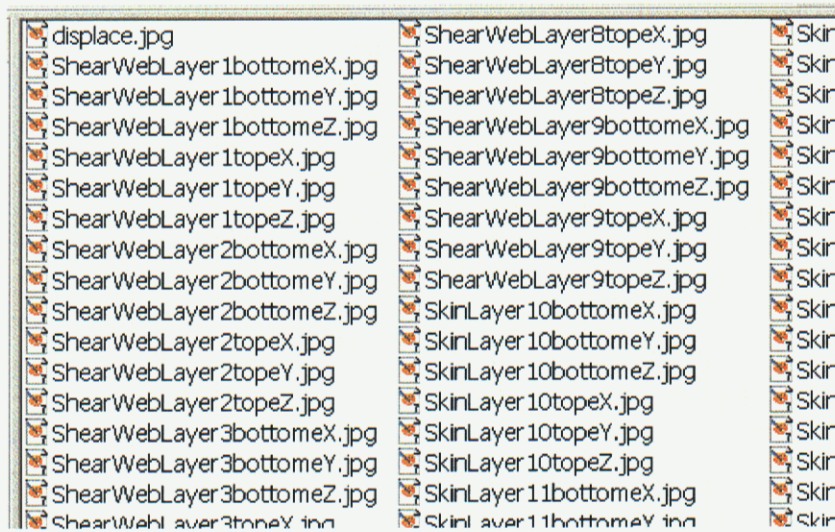

Figure 10.57 Contents of subfolder (directory) pseudoSERI8/struct/tipload/jpg.

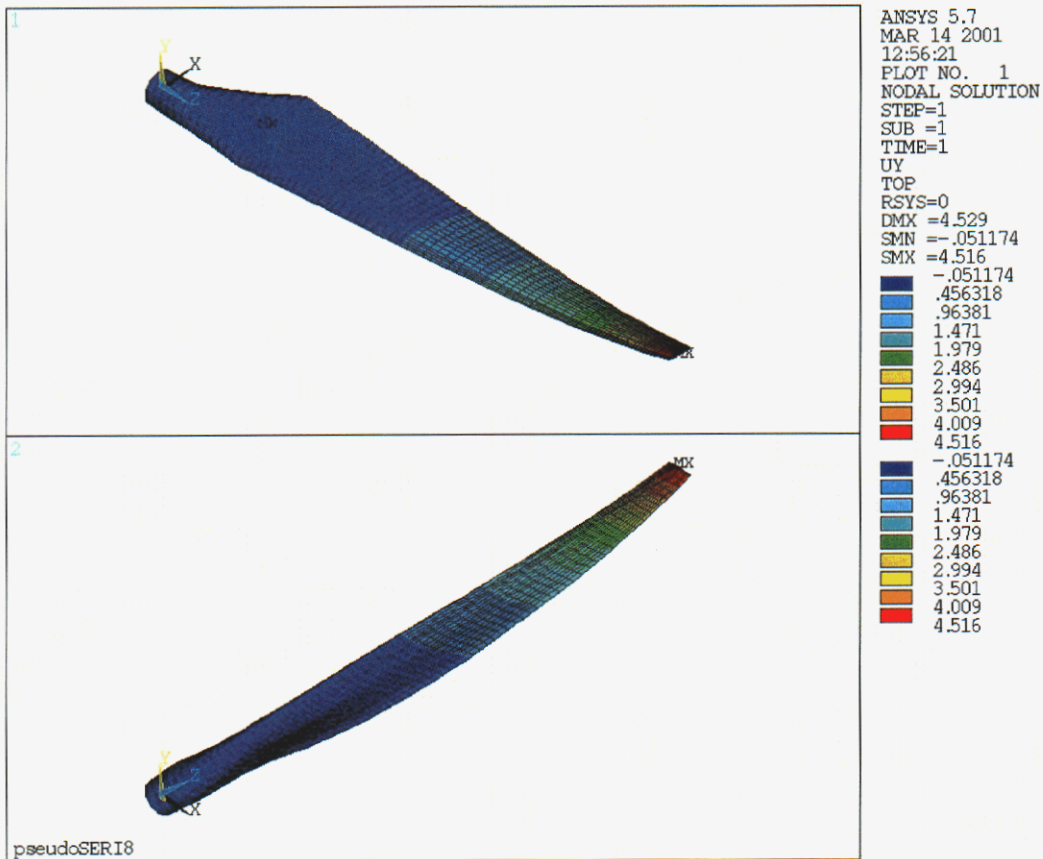

Figure 10.58 Automatically created image *displace.jpg*. The tip displacement is 4.529 inches.

Other images display the element strain in the various layers of the materials used for the blade skin as well as for the shear webs. Figure 10.59 shows the element strain at the outer surface of layer 5 in the element Y direction. This will generally be close to the direction of the blade axis. The areas of higher and lower strain may be seen in the contours. Figure 10.60 shows the element strain in the Y direction for the “top” surface of layer 4 in the shear webs. The “top” or “bottom” surface of a layer in a shear web depends on how the shear web was defined but in this case the “top” surface is towards the trailing edge of the blade. These results indicate that for the loading in question, layer 4 of the shear web has minimal strain and may be overdesigned.

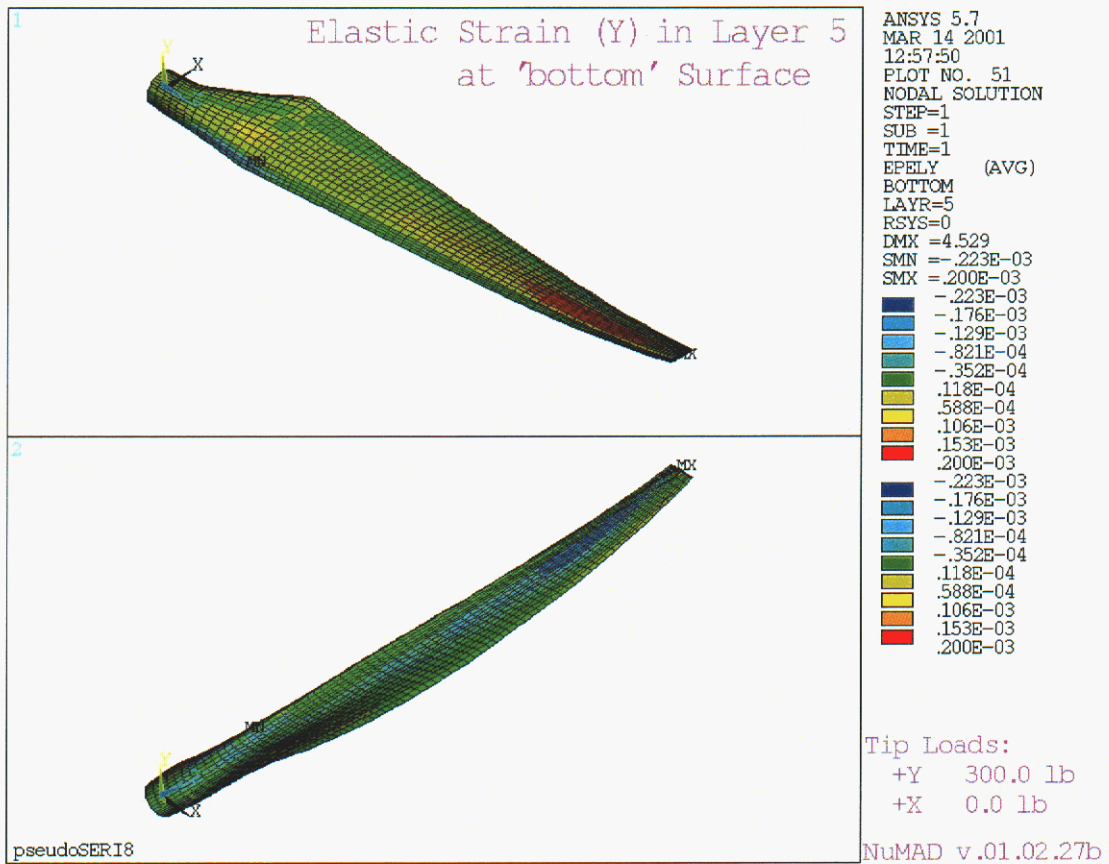

Figure 10.59 Automatically created image *SkinLayer5bottomY.jpg*. Strains are in element Y directions at outer surface of layer 5.



Figure 10.60 Automatically created image *ShearWebLayer4topeY.jpg*. Strains are in element Y directions at “top” surface of layer 4.

Corresponding output is produced for the distributed pressure (hurricane) case. Those results are found in *pseudoSERI8/struct/hurr/jpg*.

The modal subdirectory, *pseudoSERI8/modal*, contains all of the ANSYS® results files for the modal analysis. These files are named *modal.**. In addition, a simple text file name *Freqs.txt* gives a tabular listing of the frequency values obtained from the modal analysis. For each mode, six different plots of the mode shape are created. Each plot is created using a different viewing angle and the filenames are *mode1a.jpg*, *mode1b.jpg*, etc. An example of one of these images is shown in Figure 10.61. This is the fundamental (flapping) mode of the pseudoSERI8 blade and the frequency is 4.9 Hz. The blade spin rate is 60.0 rpm as specified in NuMAD.

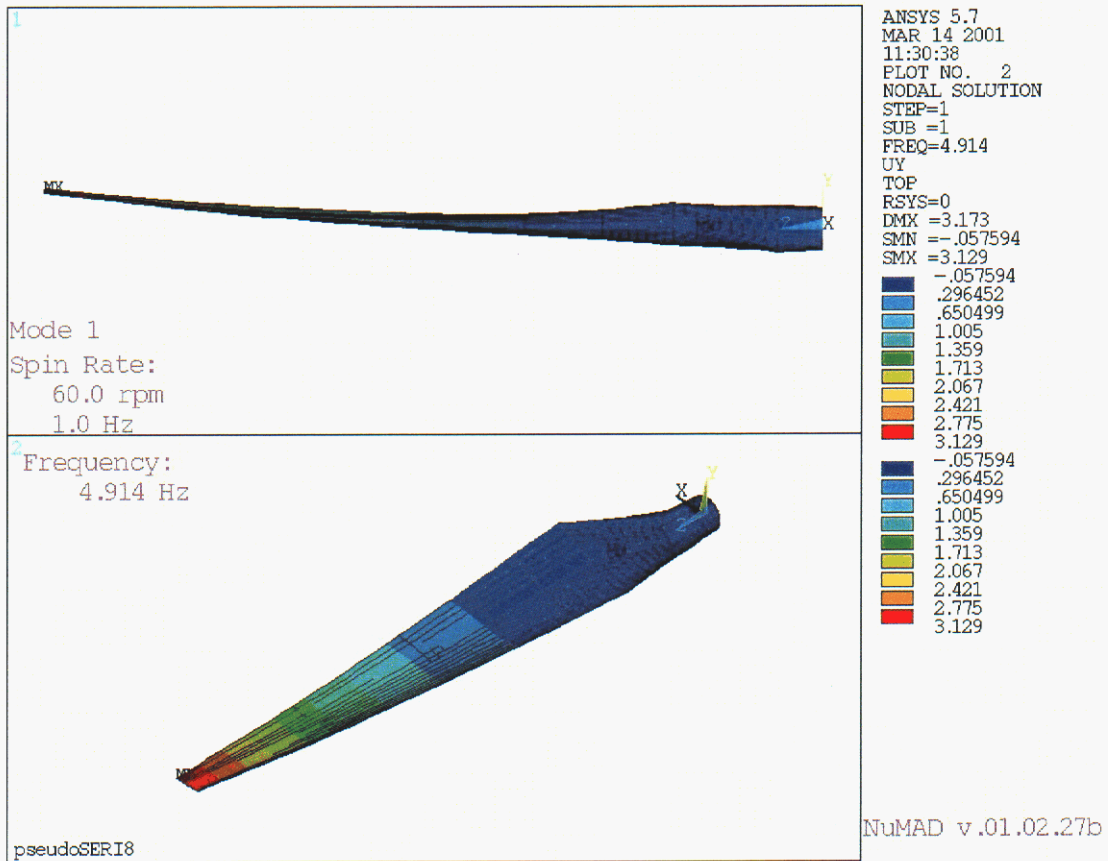

Figure 10.61 Automatically created image *mode1b.jpg*. The mode shape is most visible in the upper view and the frequency is 4.91 Hz.

CHAPTER 11 **Summary**

A new software tool, NuMAD, reduces the development time for complex three-dimensional finite element models of wind turbine blades and increases the usability of advanced capabilities on such models. A manufacturing tutorial as well as databases for airfoils and materials increase modeler efficiency. NuMAD has been developed for the Windows 2000 operating system and works with the latest release of ANSYS® (v. 5.7).

The airfoils and materials databases may be expanded by the NuMAD user and ongoing Sandia-sponsored work at Montana State University will improve the default materials database and manufacturing tutorial. As new material test data is obtained, it can quickly be made available to NuMAD users.

Potential future work includes removing the current dependence on the number of coordinate pairs defining the profiles. This is a relatively ambitious effort but it would eliminate the need for multiple definitions of the same airfoil and greatly improve parametric studies concerning shear web placement.

APPENDIX A **Graphical File Formats**

Graphical output created by NuMAD may be any of three different graphical file formats, encapsulated PostScript (eps), tagged image file format (TIFF), or Joint Photographic Experts Group (JPEG). All three are widely used and some of the characteristics of these formats are included here to assist the NuMAD user. For any NuMAD/ANSYS® analysis, any combination of the three file formats may be employed.

A.1. EPS – Encapsulated PostScript

Postscript¹ is a page description programming language developed by Adobe. Encapsulated Postscript is a restricted usage of the PostScript language.

The Postscript language is a simple interpretive programming language with powerful graphics capabilities. Its primary application is to describe the appearance of text, graphical shapes, and sampled images on printed or displayed pages, according to the Adobe imaging model. A program in this language can communicate a description of a document from a composition system to a printing system or control the appearance of text and graphics on a display. The description is high-level and device-independent.

The page description and interactive graphics capabilities of the PostScript language include the following features, which can be used in any combination:

- Arbitrary shapes made of straight lines, arcs, rectangles, and cubic curves. Such shapes may self-intersect and have disconnected sections and holes.
- Painting operators that permit a shape to be outlined with lines of any thickness filled with any color, or used as a clipping path to crop any other graphic. Colors can be specified in a variety of ways: grayscale, RGB, CMYK, and CIE-based. Certain other features are also modeled as special kinds of colors: re-peating patterns, smooth shading, color mapping, and spot colors.
- Text fully integrated with graphics. In the Adobe imaging model, text characters in both built-in and user-defined fonts are treated as graphical shapes that may be operated on by any of the normal graphics operators.
- Sampled images derived from natural sources (such as scanned photographs) or generated synthetically. The PostScript language can describe images sampled at any resolution and according to a variety of color models. It provides a number of ways to reproduce images on an output device.
- A general coordinate system that supports all combinations of linear transformations, including translation, scaling, rotation, reflection, and skewing. These transformations apply uniformly to all elements of a page, including text, graphical shapes, and sampled images.

A PostScript page description can be rendered on a printer, display, or other output device by presenting it to a PostScript interpreter controlling that device. As the interpreter executes commands to paint characters, graphical shapes, and sampled images, it converts the high-level PostScript description into the low-level raster data format for that particular device.

Normally, application programs such as document composition systems, illustrators, and computer-aided design systems generate PostScript page descriptions automatically. Programmers generally write PostScript programs only when creating new applications. However, in special situations a programmer can write PostScript programs to take advantage of capabilities of the PostScript language that are not accessible through an application program. The extensive graphics capabilities of the PostScript language are embedded in the framework of a general-purpose programming language. The language includes a conventional set of data types, such as numbers, arrays, and strings; control primitives, such as conditionals, loops, and procedures; and some unusual features, such as dictionaries. These features enable application programmers to define higher-level operations that closely match the needs of the application and then to generate commands that invoke those higher-level operations. Such a description is more compact and easier to generate than one written entirely in terms of a fixed set of basic operations. PostScript programs can be created, transmitted, and interpreted in the form of ASCII source text as defined in this book. The entire language can be described in terms of printable characters and white space. This representation is convenient for programmers to create, manipulate, and understand. It also facilitates storage and transmission of files among diverse computers and operating systems, enhancing machine independence.

There are also binary encoded forms of the language for use in suitably controlled environments—for example, when the program is assured of a fully transparent communications path to the PostScript interpreter. Adobe recommends strict adherence to the ASCII representation of PostScript programs for document interchange or archival storage.

Encapsulated Postscript is a restricted usage or subset of the PostScript language. While standard PostScript may span multiple pages, encapsulated PostScript must be a single page and usually only a portion of a page. For this reason, encapsulated PostScript includes bounding box information which may be used by applications such as word processors, etc. to insert the encapsulated PostScript file into other documents.

A.2. TIFF – Tagged Image File Format²

TIFF is an acronym for Tag(ged) Image File Format. It is one of the most popular and flexible of the current public domain raster file formats.

The TIFF format has its limitations. There are no provisions in TIFF for storing vector graphics, text annotation, etc (although such items could be easily constructed using TIFF extensions), and so if this is a requirement you would be better off with a format with broader scope, such as PostScript, CGM, or PICT. TIFF is based on file-offsets, so that it is not easily "streamable" in the way JPEG JFIF streams are.

A common complaint of TIFF is rooted in its flexibility. For example the TIFF format permits both MSB ("Motorola") and LSB ("Intel") byte order data to be stored, with a header item indicating which order is used. There are old, poorly written TIFF programs on the PC which rebelled against this and assume that all TIFF files are Intel byte order. It is very easy to write a TIFF-writer, but very difficult to write a

fully TIFF compliant reader.

TIFF uses 4-byte integer file offsets to store image data, with the consequence that a TIFF file cannot have more than 4 Gigabytes of raster data (and some files have begun to approach this boundary). However, this is 4G of compressed data, and so if the compression ratio is high enough, theoretically a TIFF image could be much larger (in fact, $2^{32}-1$ pixels square).

TIFF is primarily designed for raster data interchange. It's main strengths are a highly flexible format which is supported by numerous image processing applications. Since it was designed by developers of printers, scanners and monitors, it has a very rich space of information elements for colorimetry calibration, gamut tables, etc.

Another feature of TIFF which is also useful is the ability to decompose an image by tiles rather than scanlines. This permits much more efficient access to very large imagery which has been compressed (since one does not have to decompress an entire scanline).

Theoretically, TIFF can support imagery with multiple bands (up to 64K bands), arbitrary # bits per pixel, data cubes, and multiple images per file, including thumbnail subsampled images.

A.3. JPEG – Joint Photographic Experts Group

JPEG (pronounced "jay-peg") is a standardized image compression mechanism. JPEG stands for Joint Photographic Experts Group, the original name of the committee that wrote the standard.

JPEG is designed for compressing either full-color or gray-scale images. JPEG handles only still images, but there is a related standard called MPEG for motion pictures.

JPEG is "lossy," meaning that the decompressed image isn't quite the same as the one you started with. (There are lossless image compression algorithms, but JPEG achieves much greater compression than is possible with lossless methods.)

A useful property of JPEG is that the degree of lossiness can be varied by adjusting compression parameters. This means that the image maker can trade off file size against output image quality. You can make *extremely* small files if you don't mind poor quality; this is useful for applications such as indexing image archives. Conversely, if you aren't happy with the output quality at the default compression setting, you can jack up the quality until you are satisfied, and accept lesser compression.

Another important aspect of JPEG is that decoders can trade off decoding speed against image quality, by using fast but inaccurate approximations to the required calculations. Some viewers obtain remarkable speedups in this way. (Encoders can also trade accuracy for speed, but there's usually less reason to make such a sacrifice when writing a file.)³

There are two good reasons for using JPEG: to make your image files smaller, and to store 24-bit-per-pixel color data instead of 8-bit-per-pixel data.

Making image files smaller is a win for transmitting files across networks and for archiving libraries of images. Being able to compress a 2 Mbyte full-color file down to 100 Kbytes makes a big difference in disk space and transmission time. And JPEG can easily provide 20:1 compression of full-color data. If you are comparing GIF and JPEG, the size ratio is usually more like 4:1.

Now, it takes longer to decode and view a JPEG image than to view an image of a simpler format such as GIF. Thus using JPEG is essentially a time/space tradeoff: you give up some time in order to store or transmit an image more cheaply. But it's worth noting that when network transmission is involved, the time savings from transferring a shorter file can be greater than the time needed to decompress the file.

The second fundamental advantage of JPEG is that it stores full color information: 24 bits/pixel (16 million colors). GIF, the other image format widely used on the net, can only store 8 bits/pixel (256 or fewer colors). GIF is reasonably well matched to inexpensive computer displays --- most run-of-the-mill PCs can't display more than 256 distinct colors at once. But full-color hardware is getting cheaper all the time, and JPEG photos look *much* better than GIFs on such hardware. Within a couple of years, GIF will probably seem as obsolete as black-and-white MacPaint format does today. Furthermore, JPEG is far more useful than GIF for exchanging images among people with widely varying display hardware, because it avoids prejudging how many colors to use.

A lot of people are scared off by the term "lossy compression". The real disadvantage of lossy compression is that if you repeatedly compress and decompress an image, you lose a little more quality each time. This is a serious objection for some applications but matters not at all for many others.

A.4. Summary

Encapsulated PostScript (eps) will always produce higher quality output than either TIFF or JPEG because eps is not a rasterized format. Thus eps images may be scaled to any size without loss of image quality. Another advantage is that the format of the eps output produced by NuMAD/ANSYS® is simple text and is thus machine independent. One disadvantage of eps is that it does not usually include a rasterized preview meaning that eps images usually display (screen) as a blank rectangle though they print correctly. The other major disadvantage is that not all printers (especially economy printers) can print PostScript images. The file size of eps images may be greater or smaller than TIFF images, depending on the resolution of the TIFF image. The file size of a JPEG image will almost always be smaller than the corresponding file size of the equivalent eps image.

TIFF images are rasterized and thus have a set resolution. Displaying or printing a TIFF image at other resolutions will result in some loss of image quality. TIFF files are in a

binary format and thus may only be transferred to similar machines. Being rasterized, TIFF images display as expected in word processors and other applications and all printers should handle TIFF images. The file size of a TIFF image may be larger or smaller than the file size of the equivalent eps image but will always be larger than the file size of the equivalent JPEG image, usually significantly larger. An advantage of TIFF over JPEG is that TIFF images may be opened, closed, and edited without any significant loss in image quality. JPEG images, however, are “lossy” as described below.

JPEG images, like TIFF images, are rasterized and have a set resolution. The major difference is that the JPEG format involves a high level of compression. This results in significantly smaller file sizes but the process is “lossy.” Each open/save cycle results in some data loss (usually small). Like TIFF images, JPEG images display within word processors and should print on all printers. The file size of JPEG images is usually much smaller than the file size of equivalent eps or TIFF images.

For most NuMAD/ANSYS® situations, JPEG is probably the best choice. The file size is small, the images display properly within word processors, and all printers handle JPEG images. Due to the higher image quality, eps may be desired in some situations such as formal presentations using transparencies. The much higher resolution of modern printers (compared to visual displays) can take advantage of the vectorized format of eps images. Due to the fact that analysis output is not usually edited (hopefully), the TIFF format is not generally appealing for NuMAD use. It is included primarily for users familiar with TIFF or whose organizations have standardized on the TIFF format.

¹ Adobe Systems Incorporated, PostScript Language Reference, 3rd edition

² Unofficial TIFF, <http://home.earthlink.net/~ritter/tiff/>

³ JPEG FAQ, <http://www.faqs.org/faqs/jpeg-faq/part1/section-1.html>

⁴ JPEG FAQ, <http://www.faqs.org/faqs/jpeg-faq/part1/section-2.html>

DISTRIBUTION

T. Almeida
TPI Composites Inc.
373 Market Street
Warren, Rhode Island 02885

H. Ashley
Dept. of Aeronautics and
Astronautics Mechanical Engr.
Stanford University
Stanford, CA 94305

K. Bergey
University of Oklahoma
Aero Engineering Department
Norman, OK 73069

R. Blakemore
Enron Wind Corp.
13681 Chantico Road
Tehachapi, CA 93561

C. P. Butterfield
NREL
1617 Cole Boulevard
Golden, CO 80401

G. Bywaters
Northern Power Systems.
Box 999
Waitsfield, VT 05673

J. Cadogan
Office of Geothermal & Wind
Technology
EE-12
U.S. Department of Energy
1000 Independence Avenue SW
Washington, DC 20585

D. Cairns
Montana State University
Mechanical & Industrial Engineering Dept.
220 Roberts Hall
Bozeman, MT 59717

S. Calvert
Office of Geothermal & Wind
Technology
EE-12
U.S. Department of Energy
1000 Independence Avenue SW
Washington, DC 20585

J. Chapman
OEM Development Corp.
840 Summer St.
Boston, MA 02127-1533

Kip Cheney
PS Enterprises
222 N. El Segundo, #576
Palm Springs, CA 92262

C. Christensen
Enron Wind Corp.
13681 Chantico Road
Tehachapi, CA 93561

R. N. Clark
USDA
Agricultural Research Service
P.O. Drawer 10
Bushland, TX 79012

J. Cohen
Princeton Economic Research, Inc.
1700 Rockville Pike
Suite 550
Rockville, MD 20852

C. Coleman
Northern Power Systems
Box 999
Waitsfield, VT 05673

K. J. Deering
The Wind Turbine Company
515 116th Avenue NE
No. 263
Bellevue, WA 98004

A. J. Eggers, Jr.
RANN, Inc.
744 San Antonio Road, Ste. 26
Palo Alto, CA 94303

D. M. Eggleston
DME Engineering
1605 W. Tennessee Ave.
Midland, TX 79701-6083

P. R. Goldman
Director
Office of Geothermal & Wind
Technology
EE-12
U.S. Department of Energy
1000 Independence Avenue SW
Washington, DC 20585

G. Gregorek
Aeronautical & Astronautical Dept.
Ohio State University
2300 West Case Road
Columbus, OH 43220

D. Griffin
GEC
5729 Lakeview Drive NE, Ste. 100
Kirkland, WA 98033

C. Hansen
Windward Engineering
4661 Holly Lane
Salt Lake City, UT 84117

C. Hedley
Headwaters Composites
105 E. Adams St.
Three Forks, MT 59752

C. Hiel
W. Brandt Goldsworthy & Assoc.
23930 Madison Street
Torrance, CA 90505

S. Hock
Wind Energy Program
NREL
1617 Cole Boulevard
Golden, CO 80401

Bill Holley
3731 Oakbrook
Pleasanton, CA 94588

K. Jackson
Dynamic Design
123 C Street
Davis, CA 95616

E. Jacobsen
Enron Wind
13000 Jameson Rd.
Tehachapi, CA 93561

G. James
University of Houston
Dept. of Mechanical Engineering
4800 Calhoun
Houston, TX 77204-4792

M. Kramer
Foam Matrix, Inc.
PO Box 6394
Malibu CA 90264

D. Malcolm
GEC
5729 Lakeview Drive NE, Ste. 100
Kirkland, WA 98033

J. F. Mandell
Montana State University
302 Cableigh Hall
Bozeman, MT 59717

T. McCoy
GEC
5729 Lakeview Drive NE, Ste. 100
Kirkland, WA 98033

L. McKittrick
Montana State University
Mechanical & Industrial Engineering Dept.
220 Roberts Hall
Bozeman, MT 59717

P. Migliore
NREL
1617 Cole Boulevard
Golden, CO 80401

W. Musial
NREL
1617 Cole Boulevard
Golden, CO 80401

NWTC Library (5)
NREL
1617 Cole Boulevard
Golden, CO 80401

B. Neal
USDA
Agricultural Research Service
P.O. Drawer 10
Bushland, TX 79012

V. Nelson
Department of Physics
West Texas State University
P.O. Box 248
Canyon, TX 79016

G. Nix
NREL
1617 Cole Boulevard
Golden, CO 80401

J. W. Oler
Mechanical Engineering Dept.
Texas Tech University
P.O. Box 4289
Lubbock, TX 79409

T. Olsen
Tim Olsen Consulting
1428 S. Humboldt St.
Denver, CO 80210

R. G. Rajagopalan
Aerospace Engineering Department
Iowa State University
404 Town Engineering Bldg.
Ames, IA 50011

J. Richmond
MDEC
3368 Mountain Trail Ave.
Newbury Park, CA 91320

Michael Robinson
NREL
1617 Cole Boulevard
Golden, CO 80401

D. Sanchez
U.S. Dept. of Energy
Albuquerque Operations Office
P.O. Box 5400
Albuquerque, NM 87185

L. Schienbein
CWT Technologies, Inc.
4006 S. Morain Loop
Kennewick, WA 99337

R. Sherwin
Atlantic Orient
PO Box 1097
Norwich, VT 05055

Brian Smith
NREL
1617 Cole Boulevard
Golden, CO 80401

K. Starcher
AEI
West Texas State University
P.O. Box 248
Canyon, TX 79016

F. S. Stoddard
79 S. Pleasant St. #2A
Amherst, MA 01002

A. Swift
University of Texas at El Paso
320 Kent Ave.
El Paso, TX 79922

R. W. Thresher
NREL
1617 Cole Boulevard
Golden, CO 80401

S. Tsai
Stanford University
Aeronautics & Astronautics
Durand Bldg. Room 381
Stanford, CA 94305-4035

W. A. Vachon
W. A. Vachon & Associates
P.O. Box 149
Manchester, MA 01944

C. P. van Dam
Dept of Mech and Aero Eng.
University of California, Davis
One Shields Avenue
Davis, CA 95616-5294

B. Vick
USDA, Agricultural Research Service
P.O. Drawer 10
Bushland, TX 79012

R. E. Wilson
Mechanical Engineering Dept.
Oregon State University
Corvallis, OR 97331

S. R. Winterstein
Civil Engineering Department
Stanford University
Stanford, CA 94305

M. Zuteck
MDZ Consulting
931 Grove Street
Kemah, TX 77565

| | |
|-----------|--|
| M.S. 0847 | D. W. Lobitz, 9125 |
| M.S. 0847 | D. R. Martinez, 9124 |
| M.S. 0847 | K. E. Metzinger, 9126 |
| M.S. 0557 | T. J. Baca, 9125 |
| M.S. 0557 | T. G. Carne, 9124 |
| M.S. 0708 | H. M. Dodd, 6214 (10) |
| M.S. 0708 | T. D. Ashwill, 6214 |
| M.S. 0708 | D. E. Berg, 6214 |
| M.S. 0708 | R. R. Hill, 6214 |
| M.S. 0708 | P. L. Jones 6214 |
| M.S. 0708 | D. L. Laird, 6214 (10) |
| M.S. 0708 | M. A. Rumsey, 6214 |
| M.S. 0708 | H. J. Sutherland, 6214 |
| M.S. 0708 | P. S. Veers, 6214 |
| M.S. 0708 | J. Zayas, 6214 |
| M.S. 0958 | M. Donnelly, 1472 |
| M.S. 1490 | A. M. Lucero |
| M.S. 0612 | Review & Approval Desk, 9612 For DOE/OSTI |
| M.S. 0899 | Technical Library, 9616 (2) |
| M.S. 9018 | Central Technical Files, 8945-1 |