

Sweep-Twist Adaptive Blade

(as presented at EWEC_07, Milan, IT)

Tom Ashwill

**Technical Staff Member
Wind Energy Department
Sandia National Laboratories**

Gary Kanaby

**Director of Blade Manufacturing
Knight & Carver**

May 7, 2007



Sandia is a multiprogram laboratory operated by Sandia Corporation, a Lockheed Martin Company, for the United States Department of Energy's National Nuclear Security Administration under contract DE-AC04-94AL85000.



SNL Blade Activities

- **Current focus is on innovative blade research**
- **Concepts to lighten blades for larger rotors**
 - slender planforms with thicker airfoils
 - new materials (carbon)
- **Concepts for high quality and more reliable blades**
 - material forms
 - advanced manufacturing processes
- **Concepts for load alleviation**
 - passive bend-twist coupling with off-axis fibers or geometric sweep
 - active load control
- **Concepts for more efficient performance**
 - aerodynamic (flatbacks)
 - structural (thicker airfoils & more efficient designs - i.e. constant spar cap thickness)

**All of These Concepts Are Efforts to Sweep
More Area at About the Same Cost**

Sandia Prototype Blades



CX-100
(carbon spar)



BSDS (slender planform &
thicker airfoils)

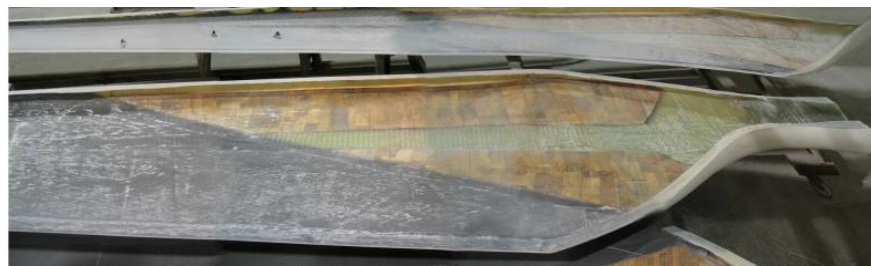

TX-100
(bend-twist)

Knight & Carver Sweep-Twist Project

- **A project with K&C entitled “Sweep-Twist Adaptive Blade” began in 11/05**
- **Goal – use geometric sweep to reduce loads in turbulent high winds, especially**
- **Allows a large rotor and new set of blades for same turbine (Test Turbine = Zond 750)**

Design Window, Tools & Parametric Variations

Design

- Design constrained to operational window of Z-750 baseline
- Analytical calculations
 - FAST, ADAMS, CFD, FEM

General Parameters

- Rotor speed (RPM)
- Blade stiffness (EI)
- Spanwise mass
- Chordwise mass
- Total blade sweep
- Sweep curve exponent

Parameters for Fine Tuning

- Planform
- Airfoil thickness vs. span
- Sweep magnitude & curve
- Spar cap position & sizing
- Airfoil panel composition
- Materials & process
- Root forward sweep

Design for Practicality

- **2.2m sweep still allows for 3 blades on trailer**
- **Sweep curve eases skin curvature**
- **Exotic/expensive materials avoided**
- **Uses existing root mold for ~60% of area**
- **Match moments to existing blades**

STAR7d (Final Configuration) vs Major Design Targets

	STAR7d	Target
• Axis mass moment (kg-m)	19,661	20,000
• Max power deflection	56.6"	56"
• Flatwise frequency	3.75p	> 3p
• Edgewise frequency	4.57p	> 4p
• Flatwise loads	Similar to existing	
• Pitch moment	Similar to existing	
• Materials	Fiberglass	Fiberglass

Pitch Moment Probability Density

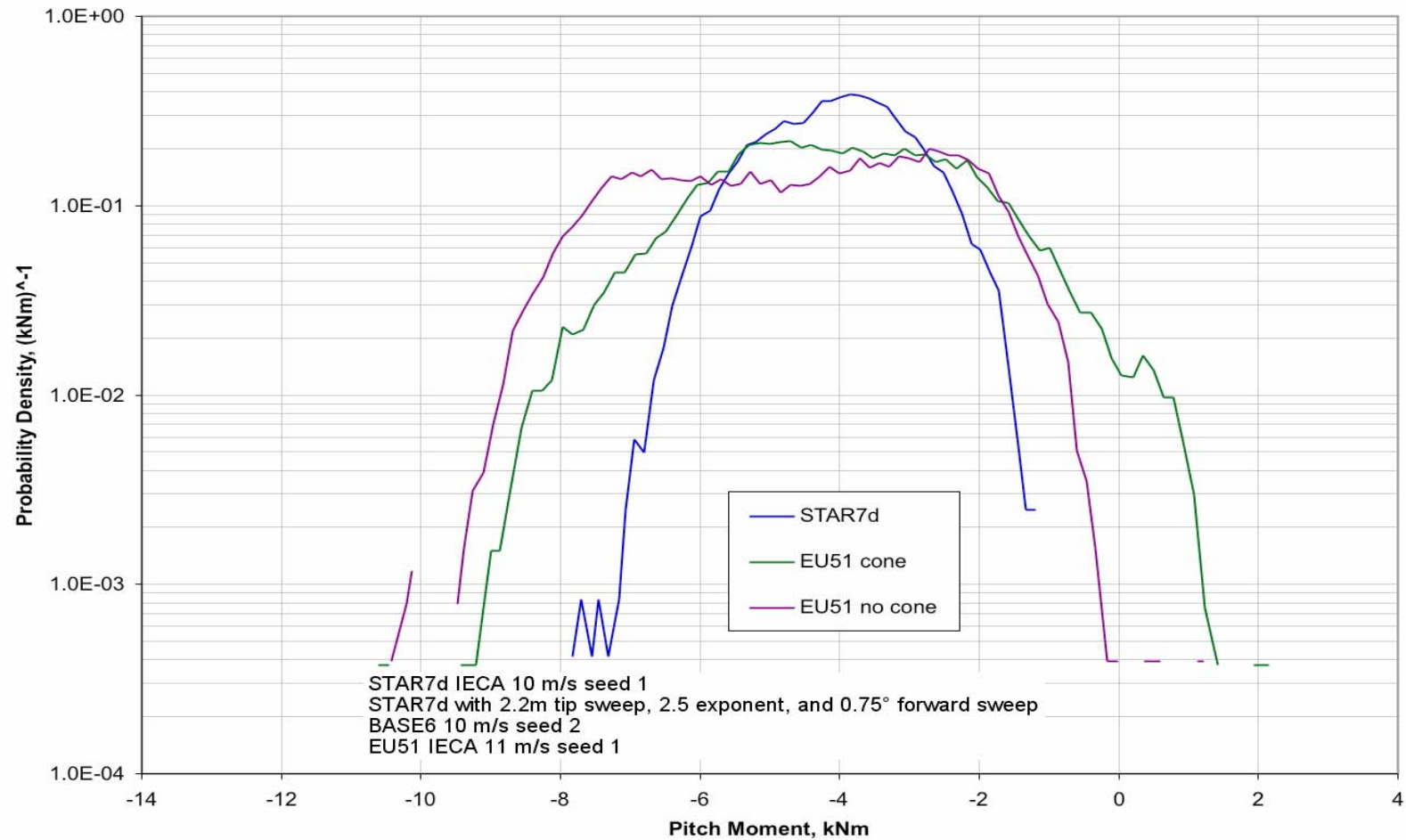

Load Probability Density

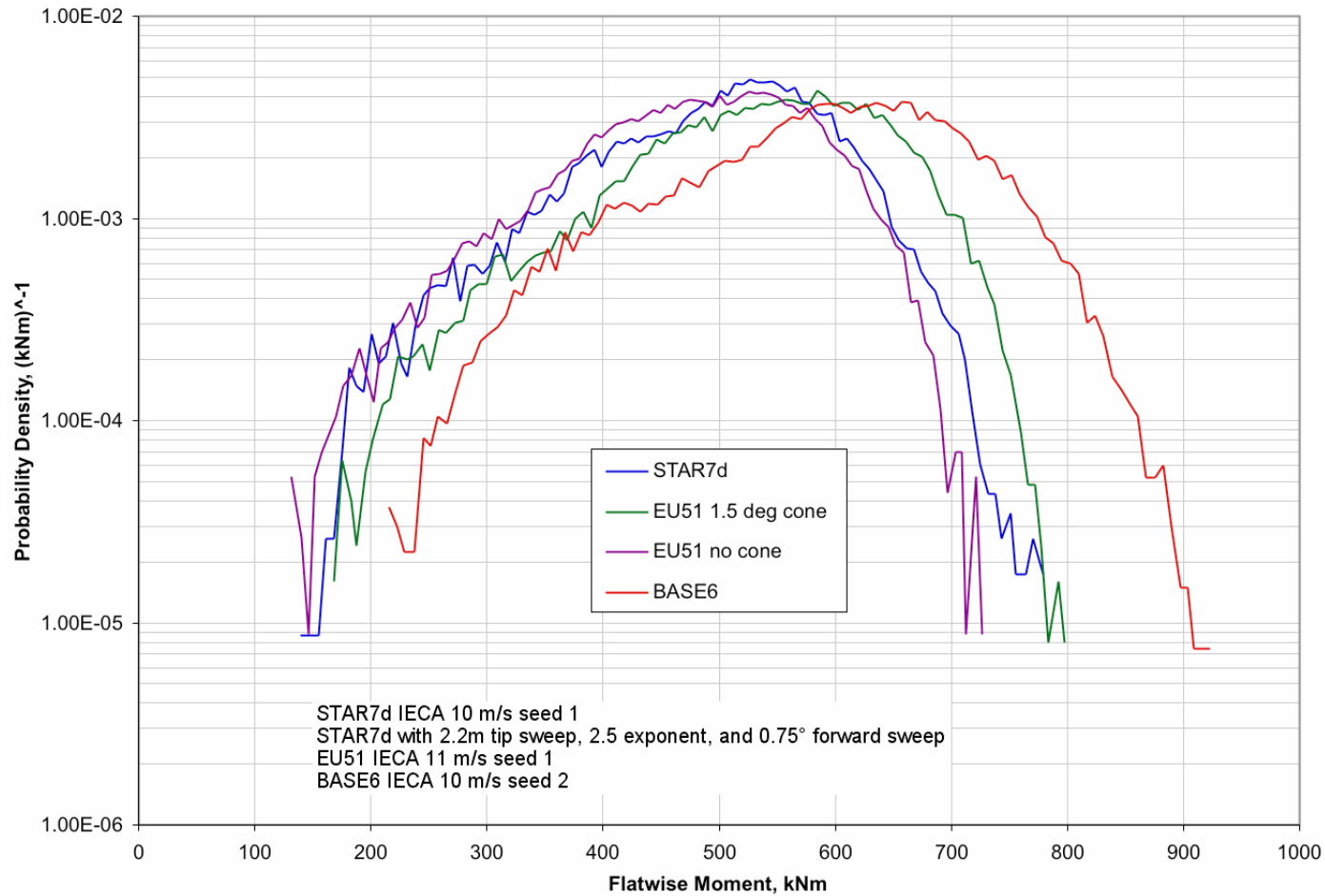

STAR7d Planform

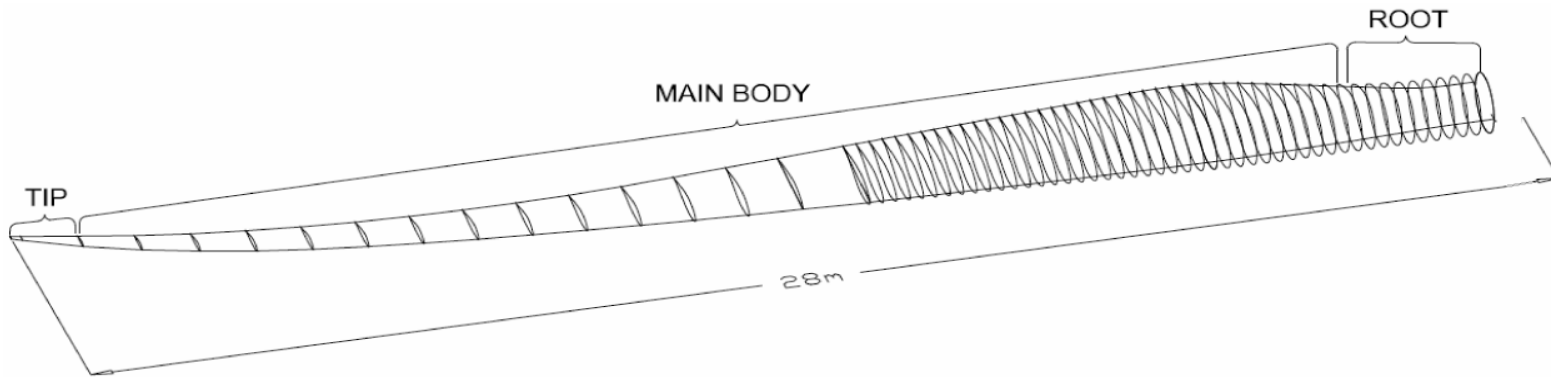

56 m Rotor
Glass Spar
Uni Roving
E = 6 msi

Root Axis Tip Sweep (m) = 2.20
(ins) = 87
Root Axis Forward Sweep (deg) = 1.5

Sweep Curve Exponent = 2.5 (2 is circular arc)
Unit Curve Depth = 0.33
Deepest At = 54%

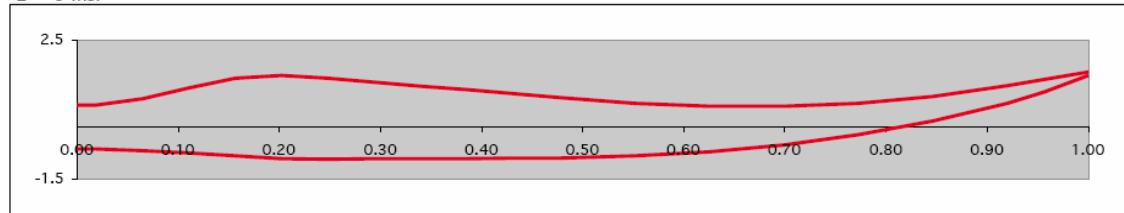

	Weighted Twist* (deg)	Tip Twist (deg)	Max Shear (psi)
K&C GlassSpar	1.74	3.07	3571

Notes: X axis is approximate blade pitch axis
Bend depth is the maximum offset of the local blade axis
relative to a straight line from the axis at the root
to the axis at the tip

* Segment twists weighted by fraction of disk area affected

Section at 55% Span & Root Attachment

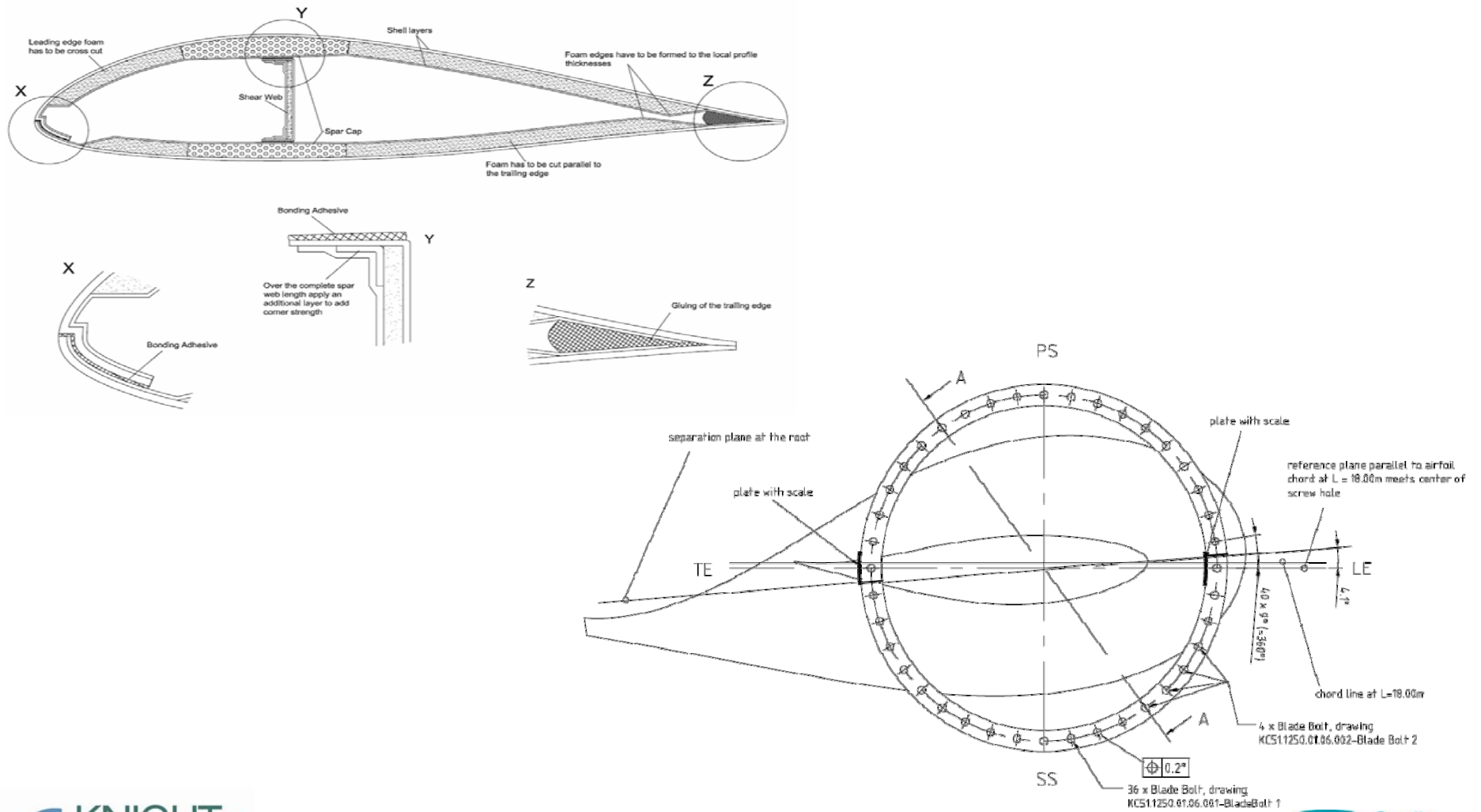

FEM Model Overview

- FE model generated using in-house script. Interior nodes located based on material definition data.
 - Linear material properties.
 - Linear geometry solution.

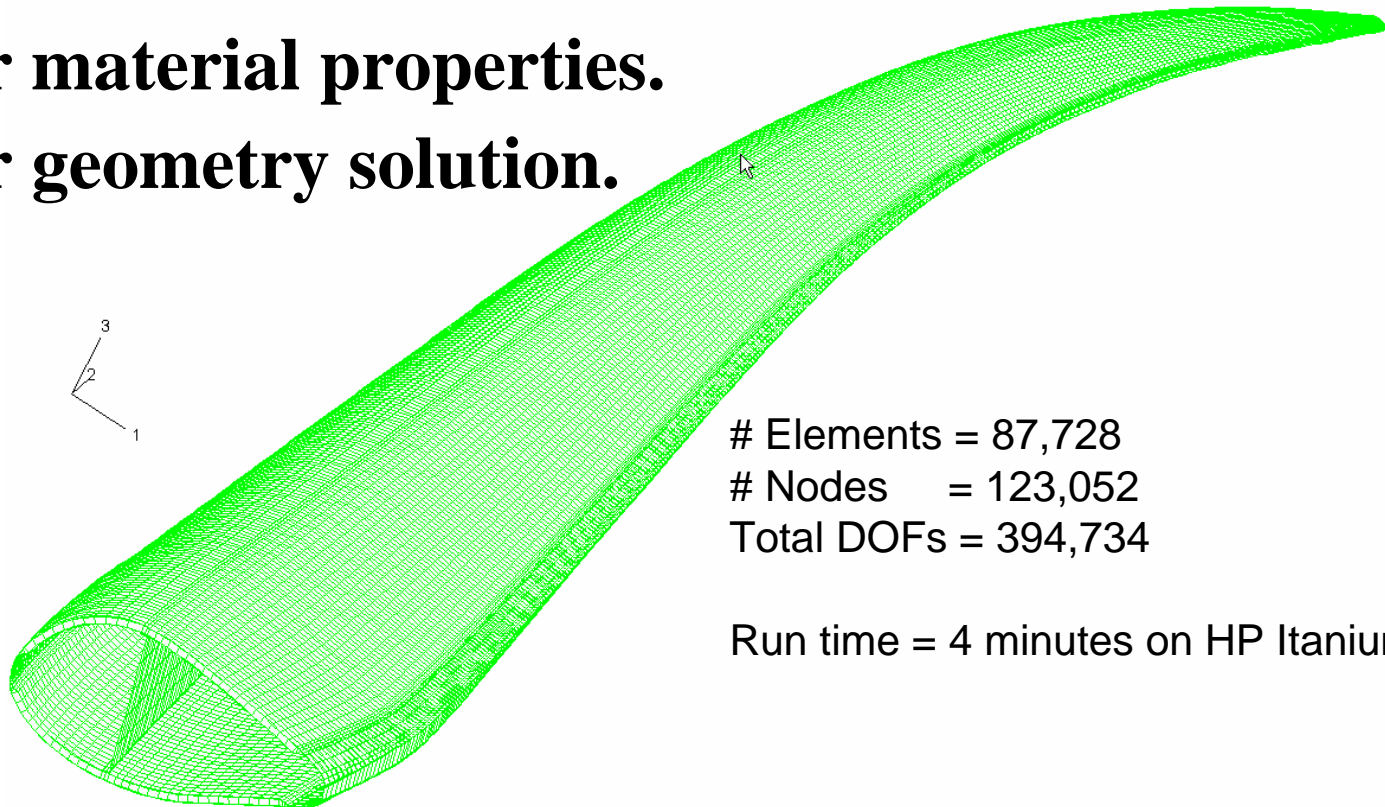

Elements = 87,728
Nodes = 123,052
Total DOFs = 394,734

Run time = 4 minutes on HP Itanium

Twist Angle - Comparison

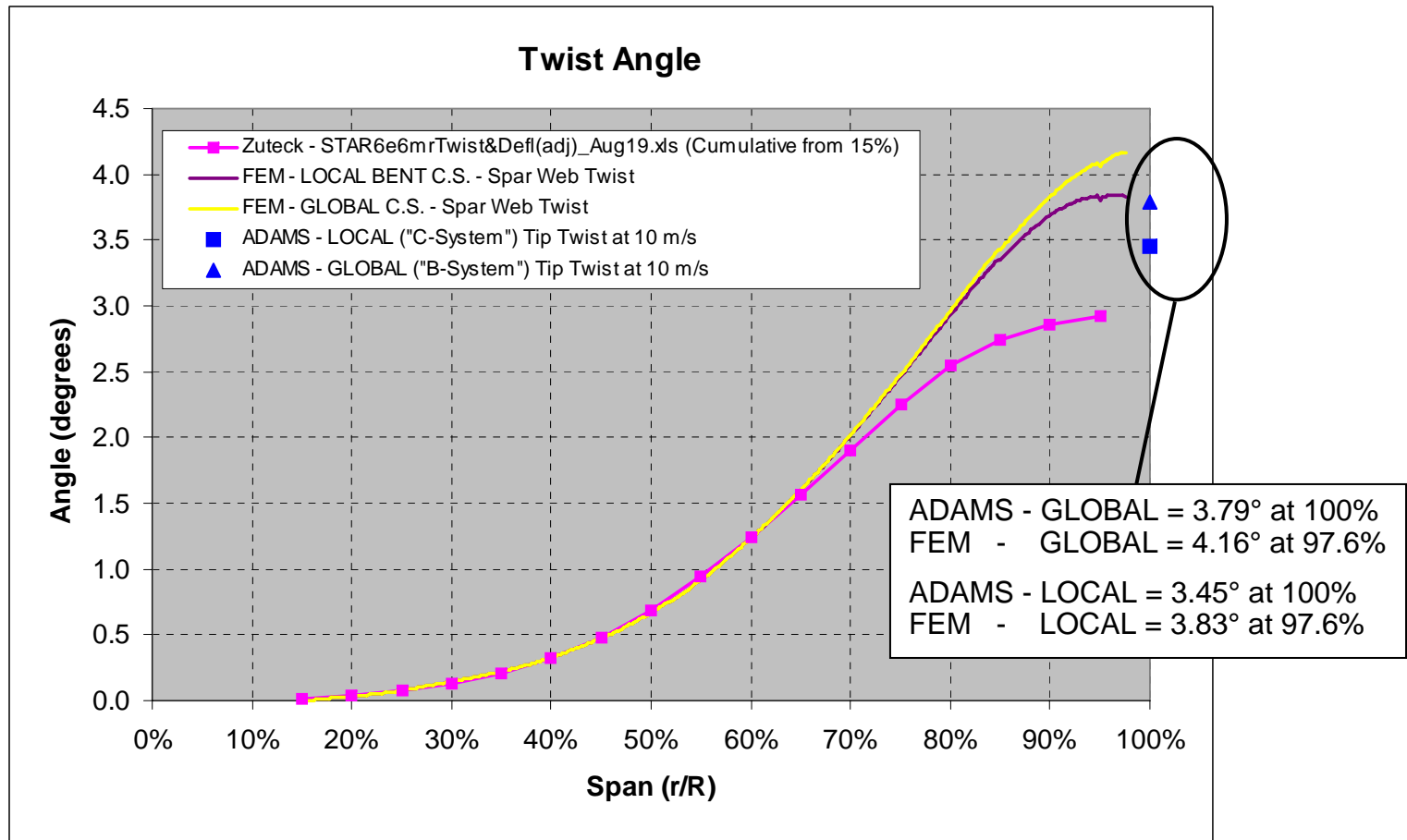

FEM predicts more twist than ADAMS but the applied thrust loads are higher.

Summary and Conclusions

- **Deflection and EI Predictions**
 - FEM matches section analysis very well for flapwise and edgewise bending deflections and stiffnesses.
- **Twist and GJ Predictions**
 - FEM predicts more twist than ADAMS but the applied thrust loads are higher.
 - FEM matches section analysis well for torsional stiffness (GJ) outboard of 35%.
- **Strain Predictions**
 - FEM strain predictions are ~12% lower than predicted by section analysis.
 - Strains are generally low and indicate a stiffness-driven design.
- **Buckling Analysis**
 - Closed-form and FE-based analysis both show high margins of safety for buckling.

The FEM successfully confirms key results from section analysis and shows that there are no 3D structural issues with the swept design.

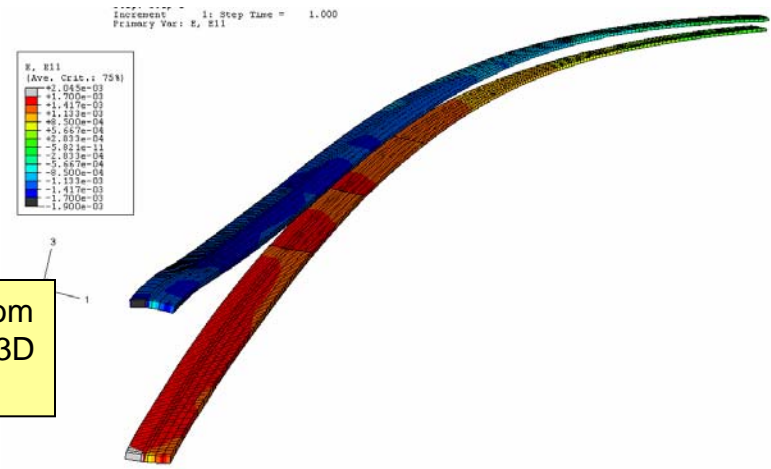
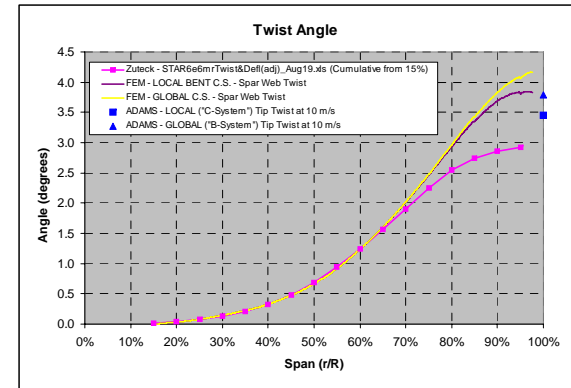
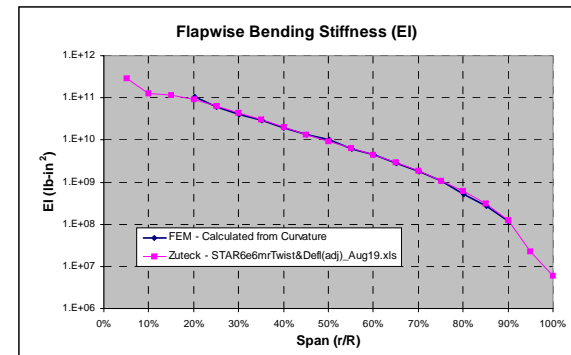

STAR Airfoil Series

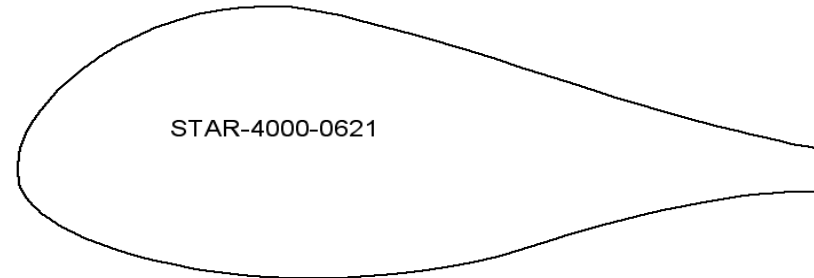
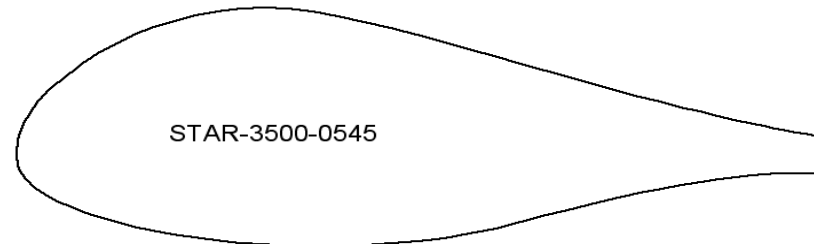
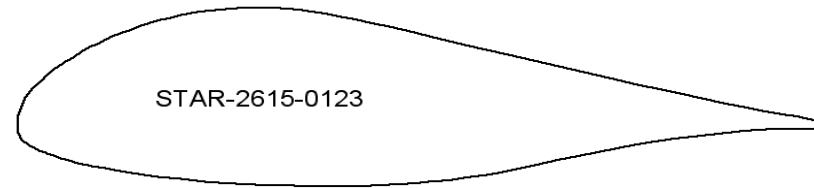
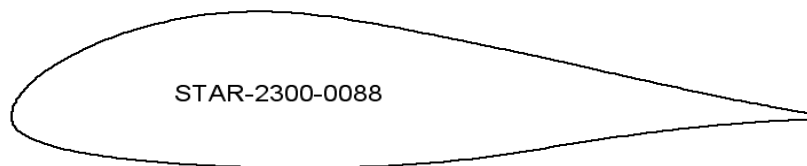
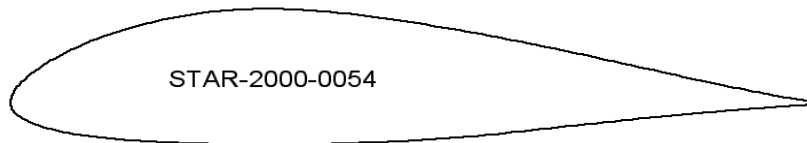
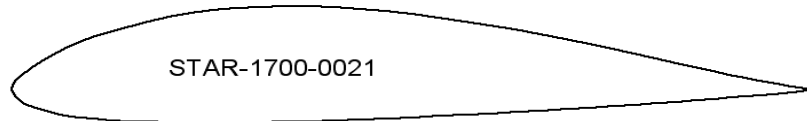
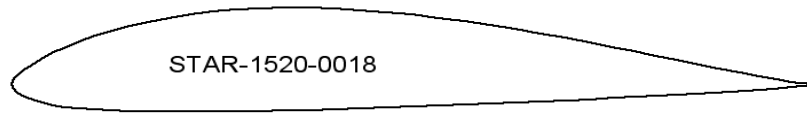

3-D Navier-Stokes Modeling

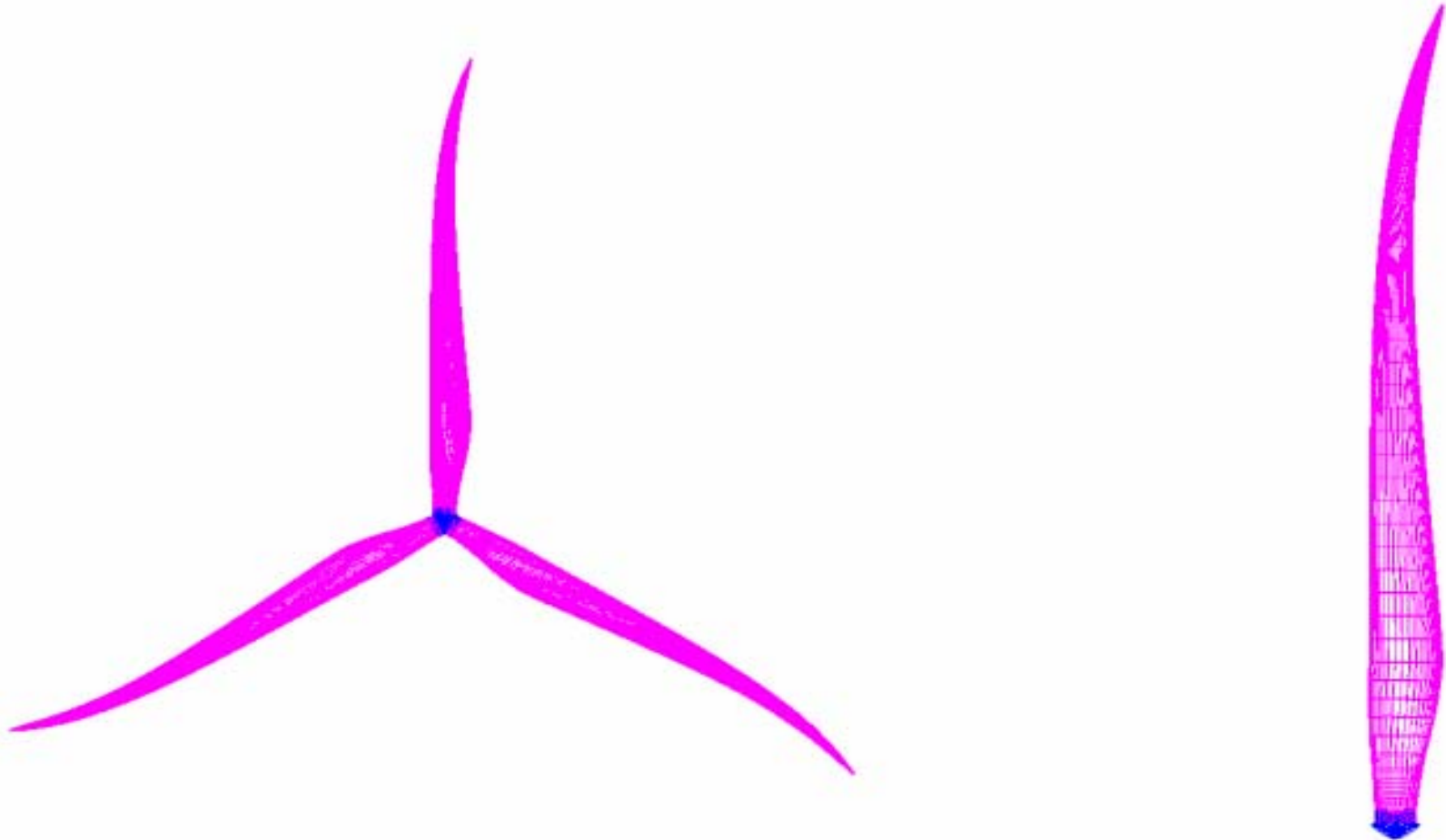

CFD Blade Tip Grid Topology

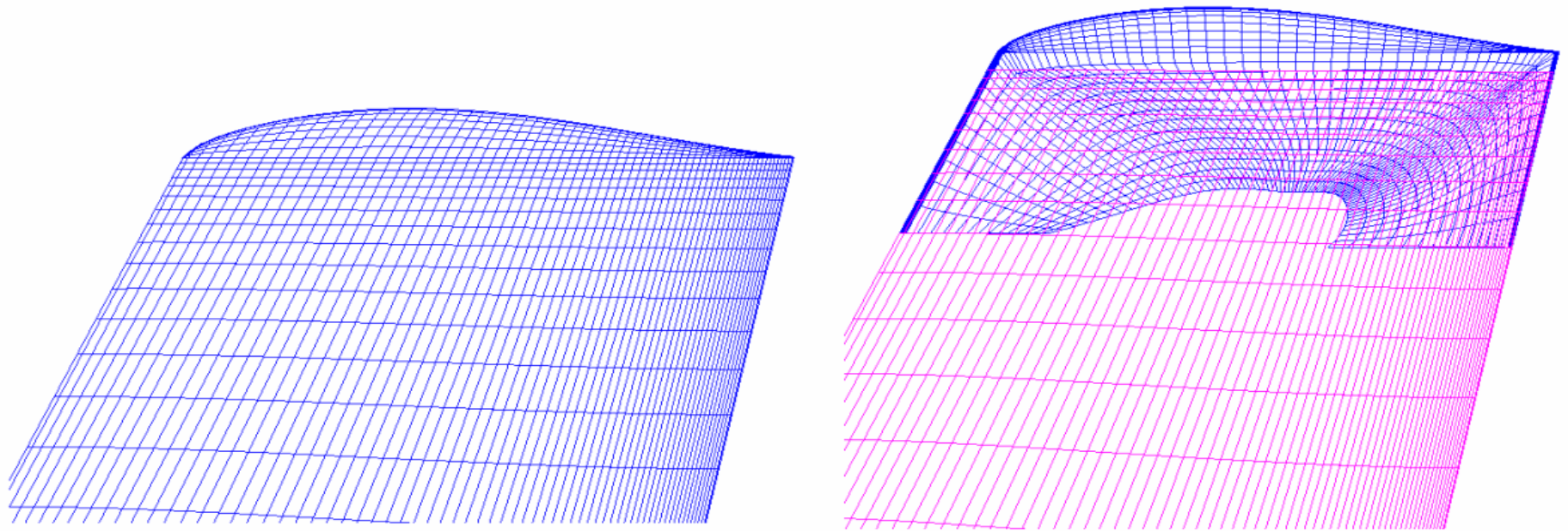

Power Curve Comparison

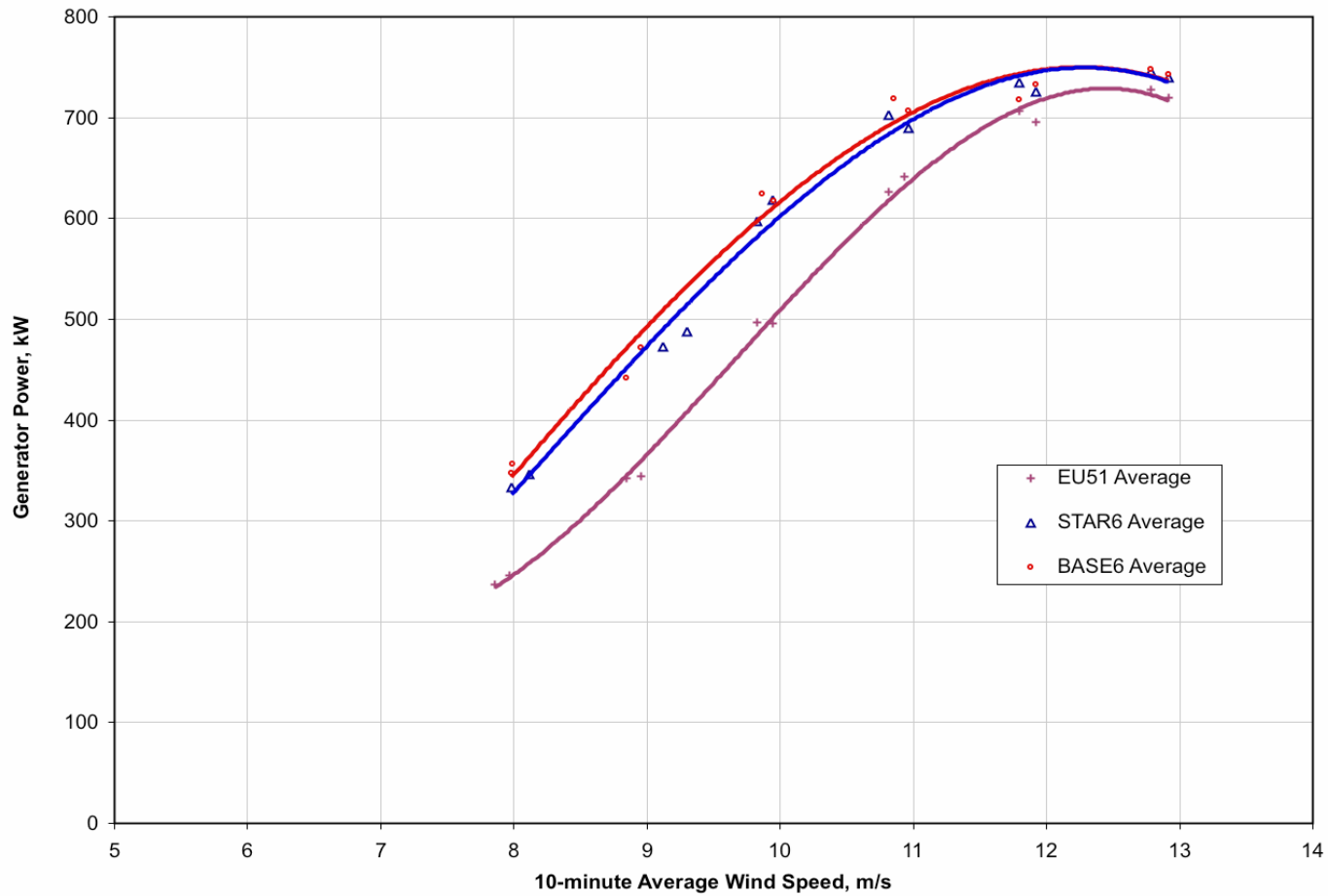

Mold Development



Blade Lay-up & Final Fabrication with Hangars Installed



Completed Laboratory Testing

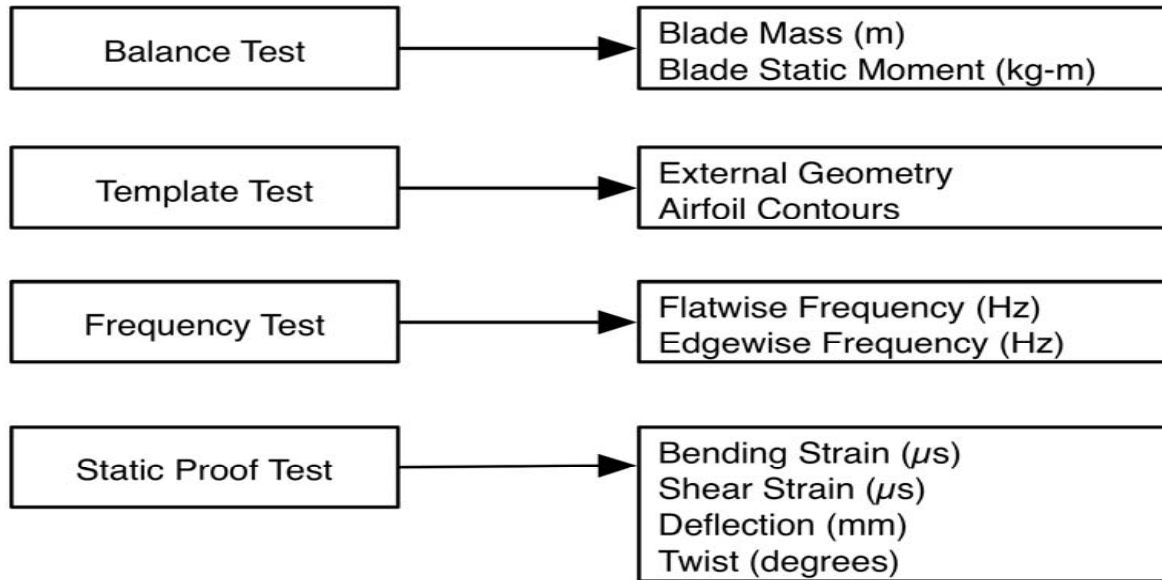

See Summary for Some Results

Laboratory Test Setup

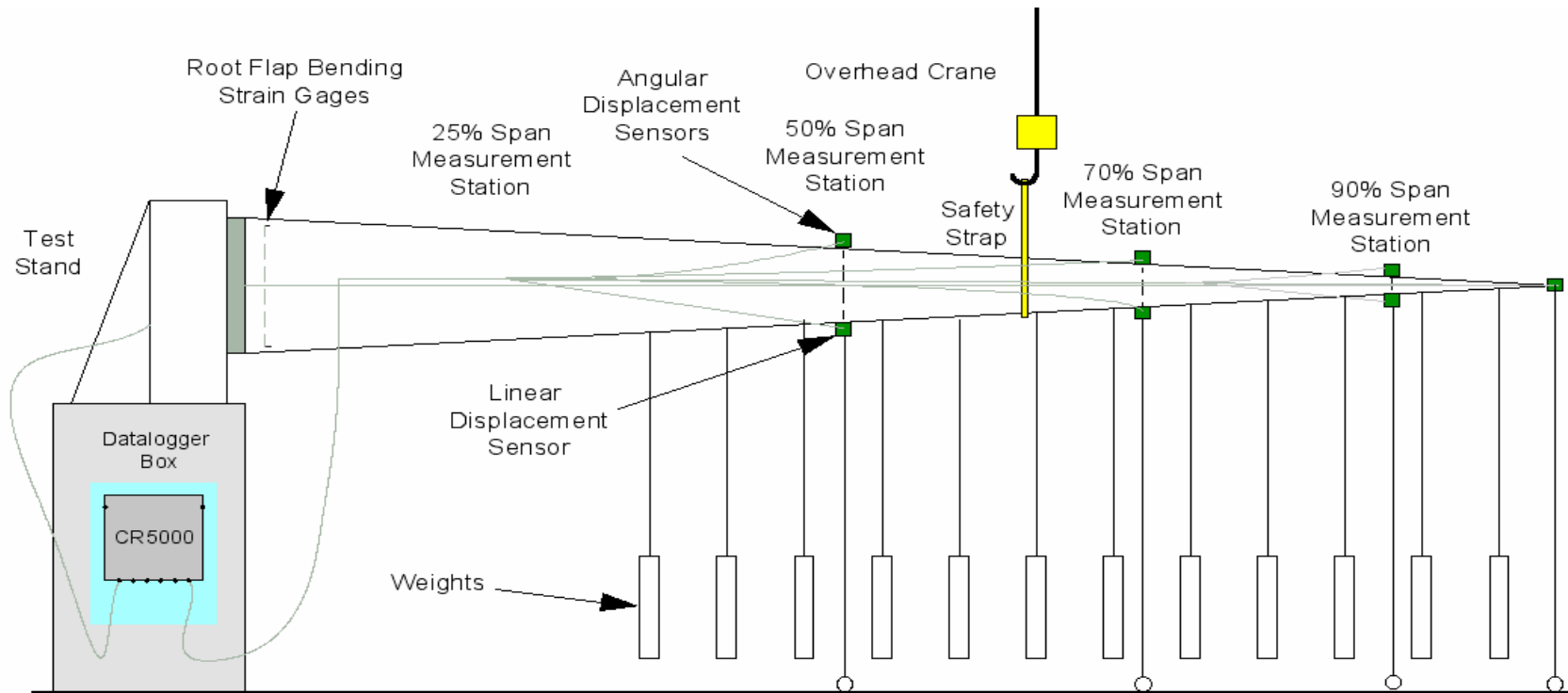

Strain Gauge Installation & Static Proof Testing



Summary

- **STAR7d swept blade length is 27.1 m**
 - 2.6 m longer than 24.5 m baseline
- **STAR7d is predicted to have same loads & grow energy capture by 5-8% compared to baseline straight blades**
- **Static testing of first prototype blade showed good match of natural frequencies & achievement of twist angles on the high side of predictions**
 - This is good news because it appears that reality is quite close to the FEM predictions & swept blade can be expected to shed loads better than was credited in the first pass design

Thank You for Your Time

Presented by

Joshua Paquette
Sandia's Wind Energy Department