

Optimized Active Aerodynamic Blade Control for Load Alleviation on Large Wind Turbines

David G. Wilson* Dale E. Berg[†] Don W. Lobitz[‡] and Jose R. Zayas[§]

Sandia National Laboratories, P.O. Box 5800, Albuquerque, NM 87185

Wind turbines are large complex dynamically flexible structures that must operate under very turbulent and unpredictable environmental conditions where the efficiency and reliability are highly dependent upon a well designed control strategy. At maximum energy capture capacity (operating region III) several popular control strategies are being investigated to help alleviate loads to prevent damage to the machinery. These include; individual pitch control, collective pitch control, and trailing-edge devices that change the effective camber of the airfoil. In this study the authors investigate the optimal deployment of one type of trailing-edge device, the micro-tabs, in conjunction with collective and individual pitch control to provide effective load alleviation for the NREL Controls Advanced Research Turbine (CART) in Colorado. The performance index maintains maximum power output while minimizing root bending moment during “actual simulated” turbulent wind conditions. The goal is to determine the micro-tab deployment profiles that keep blade root bending moments as close as possible to steady-state wind conditions during operation in a turbulent regime. A MATLAB optimization algorithm is applied as a “wrapper” around a FAST/Simulink wind turbine analysis model. The time-domain simulation results for reduced tip deflections and root bending moments are animated to visualize reduced loads with respect to micro-tab deployment profiles. The results demonstrate up to a potential 70% theoretical upper-bound reduction in root bending moments, for the cases investigated. This may allow the designer to; increase effective rotor size, extend potential life expectancy and reliability, and ultimately reduce the cost-of-energy of future large wind turbine machines.

Keywords: Wind turbine control, Trailing edge microtabs, Fatigue load reduction

I. Introduction

With wind turbine blades getting larger and heavier, can the rotor weight be reduced by adding active devices? Can active control be used to reduce fatigue loads? Can energy capture in low wind conditions be improved? These are some of the questions that are being addressed in our research program. The specific research goal that this preliminary investigation addresses is how to understand the implications and benefits of active blade control in Region III, used to alleviate high frequency dynamics and reduce peak root bending moments. To modify the blade/turbine active load control one can change blade aerodynamic characteristics through: i) surface blowing/suction, ii) VG's, surface heating, plasma, etc., or iii) changes in section shape (aileron, smart materials, microtabs). The potential benefits are feasible if active control technology is considered from the onset.

In practical applications the reduction of structural fatigue loads is important for the continued operation of wind turbines over a lifetime. One example of these types of loads is reported by Kelly, et.al.,¹ where the impact of coherent inflow turbulence on the wind turbine dynamic response is identified.

Previous field experimentation showed greatest structural fatigue damage tends to occur during nighttime hours from coherent turbulence that develops in the stable, nocturnal atmospheric

*Member of Technical Staff, Energy Systems Analysis, dwilso@sandia.gov

[†]Member of Technical Staff, Wind Energy Technology, deberg@sandia.gov

[‡]Consultant, Wind Energy Technology, dwlobit@sandia.gov

[§]Manager, Wind Energy Technology, jrzayas@sandia.gov

*boundary layer. Under such conditions, intense vertical wind shear and temperature gradients create resonant flow fields capable of imparting short-period loading and vibrational energy as wind turbine rotor blades pass through regions of organized or coherent turbulence. This energy is subsequently propagated throughout the remainder of structure, where it is often locally dissipated.*¹

A time-frequency spectral decomposition of the root flapwise load encountering coherent turbulent structure indicated that the highest level of dynamic stress energy occurred in the frequency range consisting of the first and second flap bending modes.^{1,2} It was determined that the number of stress reversals increase as the rotor passes through coherent turbulent structures.¹ Due to the nature of the load application and the existence of small values of structural damping a potential significant transient storage of vibrational energy must be dissipated. The potential of a modal dynamic amplification that may exist could contribute to a lower than designed component service lifetime.¹ Microtabs are a good candidate to help reduce these detrimental effects of high frequency dynamics and fatigue loads on wind turbines.

For wind turbines to continue a reduction in cost of energy technical advances from several areas will be required. In the area of aerodynamics, controls, and sensors several researchers have started to investigate the benefits of using advanced control for wind turbine rotor aerodynamics and geometry. In McCoy and Griffin³ two major categories of rotor aerodynamic modifications were investigated. This included active aerodynamic devices and actively controlled retractable blade rotors. Both studies showed indications of cost savings through reduced system loads and increased energy capture. van Dam et. al.,⁴⁻⁶ has investigated both computationally with CFD investigations and through experimental wind tunnel testings the preliminary feasibility of microtabs for active load control. Andersen, et.al.⁷ have developed deformable trailing edge geometry and control algorithms which also showed fatigue load reduction for both the flapwise blade root moments and the tower root moments. By enabling the trailing edge to move quickly and independently at the outboard portion of the blade then local fluctuations in the aerodynamic forces can be compensated with these trailing edge flaps.

This paper is divided into five sections. Section II provides an overview of the microtab concept. Section III discusses the development of the hybrid control system for both the pitch and microtab controllers. Section IV presents the numerical simulation results for the CART wind turbine utilizing microtab devices and Section V summarizes the results with concluding remarks.

II. Microtab Concepts and Background

The microtab concept comes from an evolutionary development of the Gurney flap (see Liebeck⁸). Some of the desirable features include: i) significant increases in C_L , ii) relatively small increase in C_D , and iii) proper sizing can increase L/D . The tab near the trailing edge deploys normal to the surface (see Fig. 1 upper-left). The deployment height is on the order of the boundary layer thickness. This effectively changes the sectional camber and modifies the trailing edge flow development also known as the so-called Kutta condition. The characteristic changes in lift for both the pressure-side and suction-side deployments are shown in Fig. 1 (lower-left). In reference⁹ van Dam, et.al. have developed a microtab wing section for wind tunnel evaluation (as shown in Fig. 1 - right). The microtab concept promotes a small, simple and fast response, retractable and controllable, lightweight and inexpensive design. The actuation can be simple “on-off” or used continuously between the upper and lower limits. The concept also features low power consumption with no explicit hinge moments. It does not require significant changes to conventional lifting surface design (i.e., manufacturing or materials) with the potential for scalability.

The specific microtab characteristics, based on experimental results, are given in Fig. 2 for both the lift and drag profiles, respectively. In the next section these profiles are used as AeroDyn¹⁰ inputs to the FAST/Simulink¹¹ dynamics and controls simulator.

III. Hybrid Control System Design

In Region III, most wind turbines have a collective and/or an individual pitch control scheme to keep the turbine operating at peak output power while at higher wind speed conditions. One of the initial goals of this project was to minimize the redesign of the control system yet understand the benefits of introducing microtabs on the blades. Therefore, a hybrid controller that combines a traditional pitch control system with

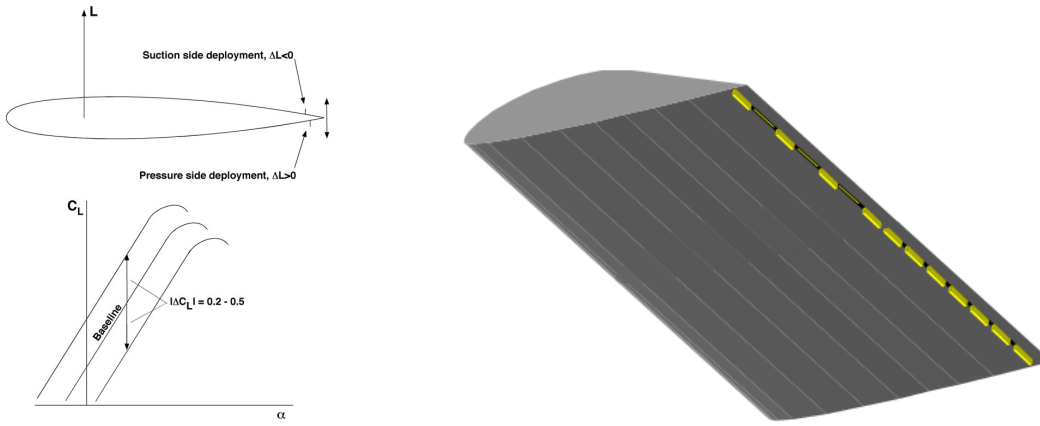

Figure 1. Microtab concept based on Kutta Condition (left) and evolution to conceptual wing section (right) - Courtesy of Professor Case van Dam⁹

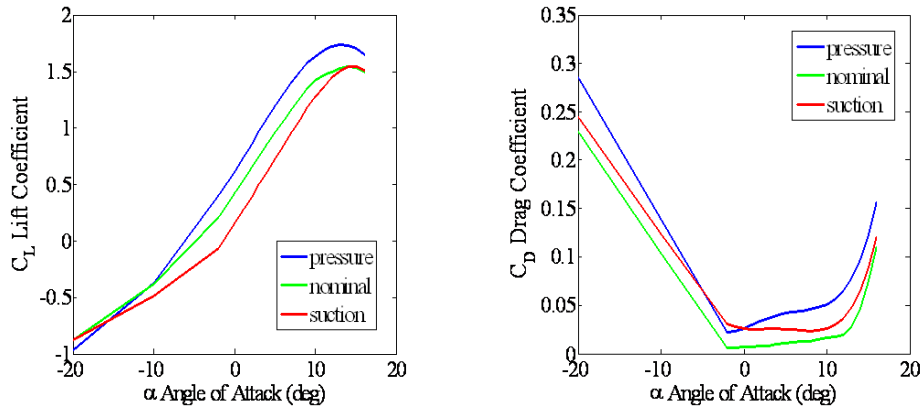

Figure 2. Microtab C_L and C_D Profiles used as input to AeroDyn software

the microtab or flap control system was developed. The pitch control system consists (from CART baseline development) of a Proportional-Integral (PI) feedback design.¹² The microtab control system consists of a Proportional-Derivative (PD) feedback design that utilizes tip deflection as the feedback signal. In addition, a nominal operating point is included as a reference input signal for the microtab feedback control.

A sequential quadratic programming optimization technique¹³ is employed to help maintain maximum generated power while reducing peak root flap bending moments. A typical performance index is defined as

$$J = \min \int_0^{T_f} [W_1(Power_{rated} - Power_{actual})^2 + W_2(M_{flap_{nominal}} - M_{flap_{actual}})^2] dt \quad (1)$$

with

$$\begin{aligned} K_{P_{pitch_{MIN}}} &\leq K_{P_{pitch}} \leq K_{P_{pitch_{MAX}}} \\ K_{I_{pitch_{MIN}}} &\leq K_{I_{pitch}} \leq K_{I_{pitch_{MAX}}} \\ K_{P_{flap_{MIN}}} &\leq K_{P_{flap}} \leq K_{P_{flap_{MAX}}} \\ K_{D_{flap_{MIN}}} &\leq K_{D_{flap}} \leq K_{D_{flap_{MAX}}} \end{aligned} \quad (2)$$

where the controller gains for pitch control $K_{P_{pitch}}$, $K_{I_{pitch}}$ and microtab flap control $K_{P_{flap}}$, $K_{D_{flap}}$ are optimized with respect to the performance index. Note that W_1 and W_2 are weighting factors between generated power and root flap bending moments. Several cases were investigated and one specific case is discussed in detail next.

The FAST/Simulink modeling environment¹¹ was used to evaluate the hybrid control system performance at a specific wind condition in Region III (see Fig. 3-left for actual IEC turbulent wind condition used

in simulation). The Controls Advanced Research Turbine (CART) (see Fig. 3 right) was utilized as the simulation testbed.¹² This testbed has a 600 kW rated power with an operating speed of 42 RPM. Several conventional 10 min turbulent wind conditions were investigated. For this discussion the first 20 seconds are shown for all the numerical simulation output results discussed below. The baseline CART FAST model was modified to incorporate the microtab control system and is shown in Fig. 4. The block in green is the CART plant while all the control system feedback loops are implemented in the Simulink block diagram.

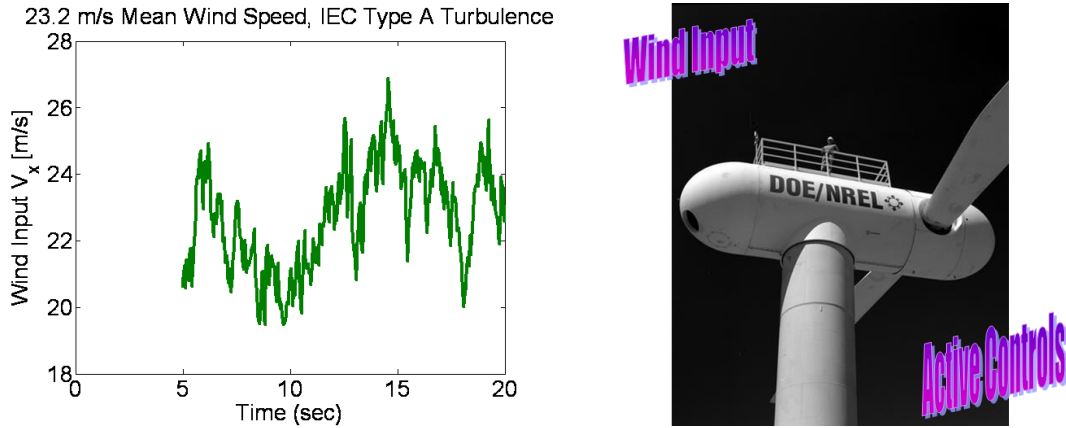

Figure 3. IEC type A Turbulent wind input (left) to CART wind turbine model (right)

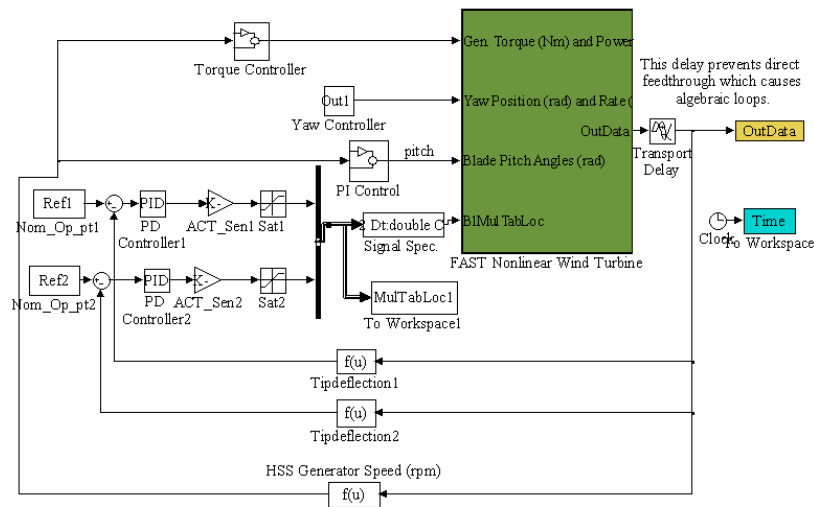

Figure 4. Dynamic simulation environment: FAST with augmented pitch and microtab control systems

IV. FAST/Simulink Control System Numerical Simulation Results

The numerical simulation results from the FAST runs are reported for both *microtabs* (shown in blue) and *no microtabs* (shown in red) cases. Figure 5 shows the blade one root flap moment response (left) and the blade one tip deflection response (right). For the flap moment a reduction of the peak moments varying from 30-50% can be observed along with a reduction in overall tip deflection. Figure 6 shows the blade one pitch angle responses (left) along with the microtab sequencing output (right). With the use of microtabs the pitch angle experiences a reduction in high frequency oscillations as compared to no microtabs. This would result in a reduction in pitch actuation over the lifetime of the wind turbine. Figure 7 shows the generator power response (left) and the rotor speed response (right). Both of the responses show a reduction in high frequency oscillations as a result of using microtabs. Since the combined control systems

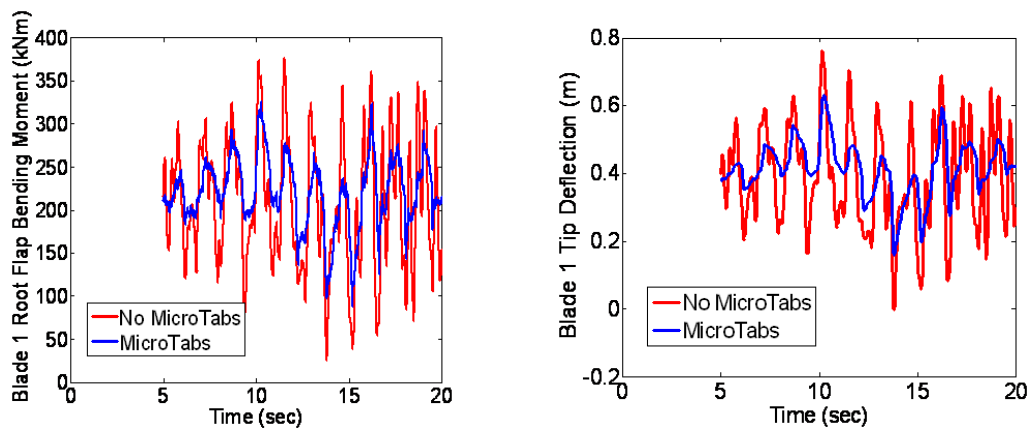

Figure 5. Numerical simulation results: blade 1 root flap moment response (left) and blade 1 tip deflection response (right)

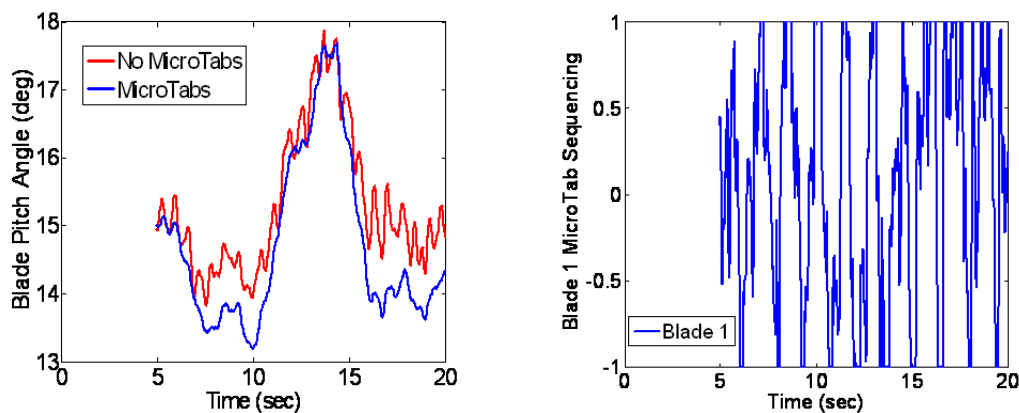

Figure 6. Numerical simulation results: blade 1 pitch angle response (left) and blade 1 microtab sequencing (right)

can potentially couple other degrees-of-freedom associated with the overall system, the tower modes were also checked. Figure 8 shows the tower base side-to-side moment response (left) and the tower base fore-aft moment response (right). A reduction of peak tower bending moments from 20-60% can be observed with the microtab case.

Finally, a blade visualization tool¹⁴ (see Fig. 9) was developed and employed to help visualize the time-domain results that combine the effects of tip deflection, blade pitch, and microtab sequencing responses have on the blade dynamic motion. In addition, the flap bending moments, tip deflection, and pitch motion are shown on bar charts that helped to show reductions in oscillations and peak magnitudes of the dynamic responses.

These preliminary results are promising for the incorporation of microtabs as trailing edge devices. Reductions in peak root bending flap moments and tip deflections were demonstrated. Reductions in high frequency oscillations for generated power and rotor speed responses were demonstrated. Additional benefit included the reduction of peak tower base bending moments.

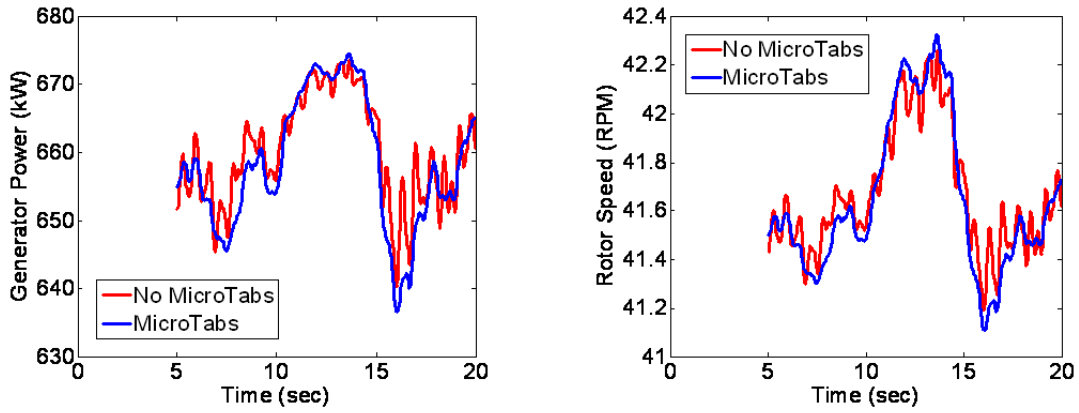

Figure 7. Numerical simulation results: generator power response (left) and rotor speed response (right)

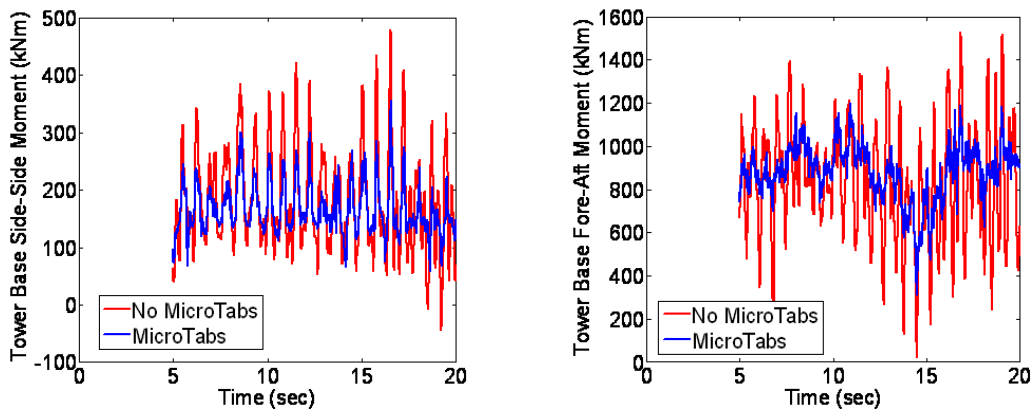

Figure 8. Numerical simulation results: tower base side-to-side moment response (left) and tower base fore-aft moment response (right)

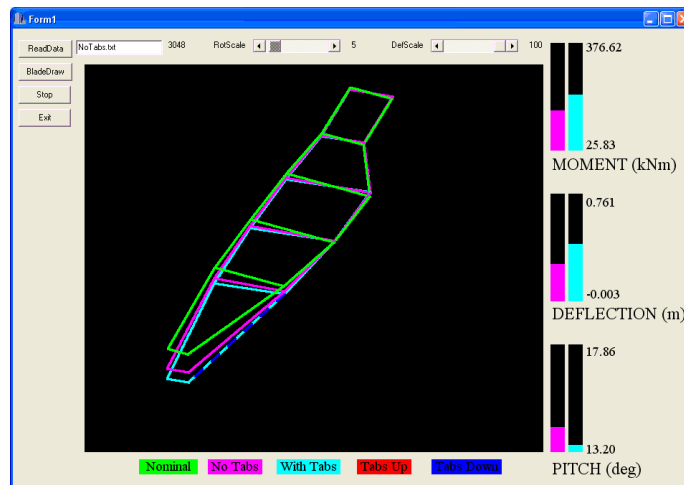

Figure 9. Microtab controller effect characterized with SNL visualization tool¹⁴

V. Summary and Future Control Design

This paper has shown an initial proof-of-concept for a active aerodynamic microtab control system. Potential benefits to the designer include: i) increase effective rotor size, ii) extend potential life expectancy and reliability, and iii) ultimately reduce the cost-of-energy of future large wind turbine machines. It has been demonstrated that active aerodynamic devices may provide substantial benefit for future wind turbine designs.

Future control design will include a further in-depth analysis of reducing loads and fatigue and the potential for increasing energy capture. A lightweight adaptive blade design with embedded sensors and actuators will be investigated that include combined blade pitch and distributed flap control systems. Nonlinear flutter control characteristics that utilize nonlinear power flow designs will be developed that identify stability boundaries and improve performance by promoting lightweight/high strength blade design. Smart structures technologies will be investigated to realize the implementation of the *smart blade* concept.

Acknowledgments

The authors would like to thank Professor van Dam and his students M. Leal and J.P. Baker for their work on the microtab concepts. We would also like to acknowledge T. Ashwill, R.D. Robinett, III and J.J. Carlson of Sandia National Laboratories and A. Wright and N. Kelly at NREL. Sandia National Laboratories is a multiprogram laboratory operated by Sandia Corporation, a Lockheed Martin Company, for the U.S. Department of Energy's National Nuclear Security Administration under contract DE-AC04-94AL85000.

References

- ¹N.D. Kelley, et. al., *The Impact of Coherent Turbulence on Wind Turbine Aeroelastic Response and Its Simulation*, WindPower 2005 Conference, NREL/CP-500-38074, August 2005
- ²J. Jonkman and J. Cotrell, *Demonstration of the Ability of RCAS to Model Wind Turbines*, National Renewable Energy Laboratory. Golden, CO. NREL/TP-500-34632, 2003.
- ³T.J. McCoy and D.A. Griffin, *Active Control of Rotor Geometry and Aerodynamics: Retractable Blades and Advanced Devices*, AWEA WINDPOWER 2007 Conference, Los Angeles, CA., June 4-6, 2007.
- ⁴D. Yen, C.P. van Dam, R.L. Smith, and S.D. Collins, *Active Load Control for Wind Turbine Blades Using MEM Translational Tabs*, Proceedings of the 2001 ASME Wind Energy Symposium (AIAA 2001-0031), Reno, Nevada, January 2001.
- ⁵D.T. Yen Nakafuji, C.P., van Dam, J. Michel, P. Morrison, *Load Control for Turbine Blades: A Non-Traditional Microtab Approach*, Proceedings of the 2002 ASME Wind Energy Symposium (AIAA 2002-0054), Reno, Nevada, January 2002.
- ⁶C.P. vanDam, et. al., *Computational and Experimental Investigation into the Effectiveness of a Microtab Aerodynamic Load Control System*, Sandia National Laboratories, August, 2004, Draft.
- ⁷P.B. Andersen, et. al., *Integrating Deformable Trailing Edge Geometry in Modern Mega-Watt Wind Turbine Controllers*, EWEA 2008 European Wind energy Conference & Exhibition, Belgium March 31 - April 3, 2008.
- ⁸R.H. Liebeck, *Design of Subsonic Airfoils for High Lift*, J. of Aircraft, Vol. 15, No. 9, September 1978, pp. 547-561.
- ⁹C.P. vanDam, et. al., *Active Load Control of Wind Turbine Blades Using Small Tabs or Flaps*, AWEA WINDPOWER 2007, Los Angeles, CA., June 4-6, 2007.
- ¹⁰D.J. Laino and A.C. Hansen, *AeroDyn User's Guide*, prepared for NREL, Windward Engineering, 2002.
- ¹¹J.M. Jonkman and M.L. Buhl, Jr., *FAST User's Guide*, NREL Technical Report, NREL/EL-500-38230, August 2005.
- ¹²A.D. Wright, *Modern Control Design for Flexible Wind Turbines*, NREL Technical Report, NREL/TP-500-35816, July 2004.
- ¹³Mathworks, *Optimization Toolbox for Use with MATLAB, User's Guide*, The Mathworks, Inc., Natick, MA 2001.
- ¹⁴J.J. Carlson, *SNL Blade Visualization Tool*, Sandia National Laboratories, Internal Report, April 2008.