

**CLEAN
COAL
TECHNOLOGY**



U.S. Department of Energy
Assistant Secretary for Fossil Energy
Washington, DC 20585

Clean Coal Technology Programs: Project Fact Sheets 2003

**Includes Clean Coal Technology Demonstration Program,
Power Plant Improvement Initiative, and
Clean Coal Power Initiative Projects**

As of May 2003

October 2003

**CLEAN
COAL
TECHNOLOGY**

**Clean Coal Technology Programs:
Project Fact Sheets 2003**

**Includes Clean Coal Technology Demonstration Program,
Power Plant Improvement Initiative, and
Clean Coal Power Initiative Projects**

As of May 2003



U.S. Department of Energy
Assistant Secretary for Fossil Energy
Washington, DC 20585

October 2003

For further information about this publication or related U.S. DOE programs please contact:

Dr. Victor K. Der
Product Line Director
U.S. Department of Energy
FE-22/Germantown Building
1000 Independence Ave. S.W.
Washington DC 20585-1290
(301) 903-2700

Dr. C. Lowell Miller
Product Line Director
U.S. Department of Energy
FE-24/Germantown Building
1000 Independence Ave. S.W.
Washington DC 20585-1290
(301) 903-9453

Comments, corrections, or contributive information may be directed to:

Project Fact Sheets 2003
c/o Gene H. Kight
Sr. Financial & Procurement Director
U.S. Department of Energy
FE-20/Germantown Building
1000 Independence Ave. S.W.
Washington DC 20585-1290
(301) 903-2624
(301) 903-9301 (fax)
gene.kight@hq.doe.gov

This report has been reproduced directly from the best available copy.

Available to DOE and DOE contractors from the Office of Scientific and Technical Information,
P.O. Box 62, Oak Ridge, Tennessee 37831; prices available from (615) 576-8401. <http://www.osti.gov>

Available to the public from the National Technical Information Service, U.S. Department of Commerce,
5285 Port Royal Rd., Springfield, Virginia 22161. <http://www.ntis.gov>

Available to the public from the National Energy Technology Laboratory's Clean Coal Technology Compendium.
<http://www.lanl.gov/projects/cctc/index.html>

Contents

1. Clean Coal Demonstration Projects

2. Active Projects

3. Completed Projects

Appendices

Index

Introduction *1-1*

Introduction *2-1*

Active Project Fact Sheets *2-2*

Environmental Control Devices *2-7*

Advanced Electric Power Generation *2-23*

Coal Processing for Clean Fuels *2-33*

Industrial Applications *2-43*

Introduction *3-1*

Completed Project Fact Sheets *3-5*

Environmental Control Devices *3-11*

 SO₂ Control Technologies *3-11*

 NO_x Control Technologies *3-33*

 Multi-Pollutant Control Technologies *3-63*

Advanced Electric Power Generation *3-89*

 Fluidized-Bed Combustion *3-89*

 Integrated Gasification Combined-Cycle *3-99*

 Advanced Combustion/Heat Engines *3-113*

Coal Processing for Clean Fuels *3-119*

Industrial Applications *3-133*

Appendix A. Acronyms, Abbreviations, and Symbols *A-1*

Index of Projects and Participants *Index-1*

Exhibits

2. Active Projects

- Exhibit 2-1, Active Project Fact Sheets by Application Category 2-3
- Exhibit 2-2, Active Project Fact Sheets by Participant 2-4
- Exhibit 2-3, Key to Milestone Charts in Project Fact Sheets 2-5
- Exhibit 2-4, ACCP Annual Production Rates 2-40
- Exhibit 2-5, ACCP Stack Emissions Survey Results 2-41

3. Completed Projects

- Exhibit 3-1, Completed CCTDP SO₂ Control Technology Projects 3-2
- Exhibit 3-2, Completed CCTDP NO_x Control Technology Projects 3-2
- Exhibit 3-3, Completed CCTDP Multi-Pollutant Control Technology Projects 3-3
- Exhibit 3-4, Completed CCTDP Advanced Electric Power Generation Technology Projects 3-3
- Exhibit 3-5, Completed CCTDP Coal Processing for Clean Fuels Technology Projects 3-4
- Exhibit 3-6, Completed CCTDP Industrial Applications Technology Projects 3-4
- Exhibit 3-7, Completed CCTDP Project Fact Sheets by Application Category 3-6
- Exhibit 3-8, Completed CCTDP Project Fact Sheets by Participant 3-8
- Exhibit 3-9, Key to Milestone Charts in Project Fact Sheets 3-9
- Exhibit 3-10, Variables and Levels Used in GSA Factorial Testing 3-14
- Exhibit 3-11, GSA Factorial Testing Results 3-14
- Exhibit 3-12, Cost Comparison of GSA and WLFO 3-15
- Exhibit 3-13, Pure Air SO₂ Removal Performance 3-26
- Exhibit 3-14, Estimated Costs for an AFGD System 3-27
- Exhibit 3-15, Flue Gas Desulfurization Economics 3-27
- Exhibit 3-16, Operation of CT-121 Scrubber 3-30
- Exhibit 3-17, SO₂ Removal Efficiency 3-30
- Exhibit 3-18, CT-121 Particulate Capture Performance 3-31
- Exhibit 3-19, CT-121 Air Toxics Removal 3-31
- Exhibit 3-20, LOI Performance Test Results 3-36
- Exhibit 3-21, NO_x vs. LOI Tests—All Sensitivities 3-36
- Exhibit 3-22, Typical Trade-Offs in Boiler Optimization 3-36

Exhibit 3-23, Major Elements of Optimization System	3-37
Exhibit 3-24, Coal Reburning Test Results	3-40
Exhibit 3-25, Coal Reburning Economics	3-41
Exhibit 3-26, NO _x Data from Cherokee Station, Unit No. 3	3-48
Exhibit 3-27, Reactor Baseline Conditions	3-56
Exhibit 3-28, Catalysts Tested	3-56
Exhibit 3-29, Average SO ₂ Oxidation Rate	3-56
Exhibit 3-30, SCR Design Criteria for Economic Evaluation	3-57
Exhibit 3-31, SCR Economics by Unit Size	3-57
Exhibit 3-32, SCR Economics by NO _x Removal	3-57
Exhibit 3-33, LNCFS™ Configurations	3-60
Exhibit 3-34, Concentric Firing Concept	3-60
Exhibit 3-35, Unit Performance Impacts Based on Long-Term Testing	3-61
Exhibit 3-36, Average Annual NO _x Emissions and Percent Reduction	3-61
Exhibit 3-37, LIMB SO ₂ Removal Efficiencies	3-70
Exhibit 3-38, LIMB Capital Cost Comparison	3-71
Exhibit 3-39, LIMB Annual Levelized Cost Comparison	3-71
Exhibit 3-40, Effect of Limestone Grind	3-82
Exhibit 3-41, Boiler Load Parametric Testing of LNB/OFA System	3-86
Exhibit 3-42, CO Emissions During Parametric Testing	3-86
Exhibit 3-43, Effect of Bed Temperature on Ca/S Requirement	3-96
Exhibit 3-44, Calcium Requirements and Sulfur Retentions for Various Fuels	3-97
Exhibit 3-45, Wabash Thermal Performance Summary	3-110
Exhibit 3-46, Wabash River Coal Gasification Repowering Project Production Statistics	3-111
Exhibit 3-47, Healy Performance Goals and Demonstration Test Program Results	3-116
Exhibit 3-48, Healy SDA Performance Test Results and Performance Guarantees	3-117
Exhibit 3-49, ENCOAL Production	3-130
Exhibit 3-50, Summary of Emissions and Removal Efficiencies	3-144
Exhibit 3-51, Schematic of Pulse Combustor Operation	3-148
Exhibit 3-52, Schematic of ThermoChem's Process Development Unit	3-149

Project Fact Sheets by Project Name

- 10-MWe Demonstration of Gas Suspension Absorption (AirPol, Inc.) 3-12
- 180-MWe Demonstration of Advanced Tangentially Fired Combustion Techniques for the Reduction of NO_x Emissions from Coal-Fired Boilers (Southern Company Services, Inc.) 3-58
- Achieving NSPS Emission Standards Through Integration of Low-NO_x Burners with an Optimization Plan for Boiler Combustion (Sunflower Electric Power Corporation) 2-8
- Advanced Coal Conversion Process Demonstration (Western Syncoal LLC) 2-38
- Advanced Cyclone Combustor with Internal Sulfur, Nitrogen, and Ash Control (Coal Tech Corporation) 3-138
- Advanced Flue Gas Desulfurization Demonstration Project (Pure Air on the Lake, L.P.) 3-24
- Advanced Multi-Product Coal Utilization By-Product Processing Plant (University of Kentucky Research Foundation) 2-48
- Big Bend Power Station Neural Network-Sootblower Optimization (Tampa Electric Company) 2-16
- Blast Furnace Granular-Coal Injection System Demonstration Project (Bethlehem Steel Corporation) 3-134
- Cement Kiln Flue Gas Recovery Scrubber (Passamaquoddy Tribe) 3-142
- Clean Coal Diesel Demonstration Project (TIAX, LLC) 2-30
- Clean Power from Integrated Coal/Ore Reduction (CPICOR™) (CPICOR™ Management Company LLC) 2-44
- Commercial Demonstration of the Manufactured Aggregate Processing Technology Utilizing Spray Dryer Ash (Universal Aggregates, LLC) 2-46
- Commercial-Scale Demonstration of the Liquid Phase Methanol (LPMEOH™) Process (Air Products Liquid Phase Conversion Company, L.P.) 3-120
- Confined Zone Dispersion Flue Gas Desulfurization Demonstration (Bechtel Corporation) 3-16
- Demonstration of a Full-Scale Retrofit of the Advanced Hybrid Particulate Collector Technology (Otter Tail Power Company) 2-14
- Demonstration of Advanced Combustion Techniques for a Wall-Fired Boiler (Southern Company Services, Inc.) 3-34
- Demonstration of Coal Reburning for Cyclone Boiler NO_x Control (The Babcock & Wilcox Company) 3-38
- Demonstration of Innovative Applications of Technology for the CT-121 FGD Process (Southern Company Services, Inc.) 3-28
- Demonstration of Integrated Optimization Software at the Baldwin Energy Complex (NeuCo, Inc.) 2-18
- Demonstration of Selective Catalytic Reduction Technology for the Control of NO_x Emissions from High-Sulfur, Coal-Fired Boilers (Southern Company Services, Inc.) 3-54
- Development of Hybrid FLGR/SNCR/SCR Advanced NO_x Control (TIAX, LLC) 2-10
- Development of the Coal Quality Expert™ (ABB Combustion Engineering, Inc., and CQ Inc.) 3-124
- ENCOAL® Mild Coal Gasification Project (ENCOAL Corporation) 3-128
- Enhancing the Use of Coals by Gas Reburning and Sorbent Injection (Energy and Environmental Research Corporation) 3-76
- Evaluation of Gas Reburning and Low-NO_x Burners on a Wall-Fired Boiler (Energy and Environmental Research Corporation) 3-46
- Full-Scale Demonstration of Low-NO_x Cell Burner Retrofit (The Babcock & Wilcox Company) 3-42

Gilberton Coal-to-Clean Fuels and Power Co-Production Project (WMPI PTY., LLC) 2-36

Greenidge Multi-Pollutant Control Project (CONSOL Energy, Inc.) 2-12

Healy Clean Coal Project (Alaska Industrial Development and Export Authority) 3-114

Integrated Dry NO_x/SO₂ Emissions Control System (Public Service Company of Colorado) 3-84

JEA Large-Scale CFB Combustion Demonstration Project (JEA) 2-24

Kentucky Pioneer Energy IGCC Demonstration Project (Kentucky Pioneer Energy, LLC) 2-28

LIFAC Sorbent Injection Desulfurization Demonstration Project (LIFAC-North America) 3-20

Lignite Fuel Enhancement (Great River Energy) 2-34

LIMB Demonstration Project Extension and Coolside Demonstration (The Babcock & Wilcox Company) 3-68

Micronized Coal Reburning Demonstration for NO_x Control (New York State Electric & Gas Corporation) 3-50

Milliken Clean Coal Technology Demonstration Project (New York State Electric & Gas Corporation) 3-80

Next Generation CFB Coal Generating Unit (Colorado Springs Utilities) 2-26

Nucla CFB Demonstration Project (Tri-State Generation and Transmission Association, Inc.) 3-94

Piñon Pine IGCC Power Project (Sierra Pacific Power Company) 3-100

Pulse Combustor Design Qualification Test (ThermoChem, Inc.) 3-146

SNOX™ Flue Gas Cleaning Demonstration Project (ABB Environmental Systems) 3-64

SO_x-NO_x-Rox Box™ Flue Gas Cleanup Demonstration Project (The Babcock & Wilcox Company) 3-72

Tampa Electric Integrated Gasification Combined-Cycle Project (Tampa Electric Company) 3-104

Tidd PFBC Demonstration Project (The Ohio Power Company) 3-90

TOXECON Retrofit for Mercury and Multi-Pollutant Control on Three 90 MW Coal-Fired Boilers (Wisconsin Electric Power Company) 2-20

Wabash River Coal Gasification Repowering Project (Wabash River Coal Gasification Repowering Project Joint Venture) 3-108

Western Greenbrier Co-Production Demonstration Project (Western Greenbrier Co-Generation, LLC) 2-50

Project Fact Sheets by Participant

- ABB Combustion Engineering, Inc., and CQ Inc. (Development of the Coal Quality Expert™) 3-124
- ABB Environmental Systems (SNOX™ Flue Gas Cleaning Demonstration Project) 3-64
- Air Products Liquid Phase Conversion Company, L.P. (Commercial-Scale Demonstration of the Liquid-Phase Methanol (LPMEOH™) Process) 3-120
- AirPol, Inc. (10-MWe Demonstration of Gas Suspension Absorption) 3-12
- Alaska Industrial Development and Export Authority (Healy Clean Coal Project) 3-114
- Babcock & Wilcox Company, The (Demonstration of Coal Reburning for Cyclone Boiler NO_x Control) 3-38
- Babcock & Wilcox Company, The (Full-Scale Demonstration of Low-NO_x Cell Burner Retrofit) 3-42
- Babcock & Wilcox Company, The (LIMB Demonstration Project Extension and Coolside Demonstration) 3-68
- Babcock & Wilcox Company, The (SO_x-NO_x-Rox Box™ Flue Gas Cleanup Demonstration Project) 3-72
- Bechtel Corporation (Confined Zone Dispersion Flue Gas Desulfurization Demonstration) 3-16
- Bethlehem Steel Corporation (Blast Furnace Granular-Coal Injection System Demonstration Project) 3-134
- Coal Tech Corporation (Advanced Cyclone Combustor with Internal Sulfur, Nitrogen, and Ash Control) 3-138
- Colorado Springs Utilities (Next Generation CFB Coal Generating Unit) 2-26
- CONSOL Energy, Inc. (Greenidge Multi-Pollutant Control Project) 2-12
- CPICOR™ Management Company LLC (Clean Power from Integrated Coal/Ore Reduction (CPICOR™)) 2-44
- CQ Inc. (see ABB Combustion Engineering and CQ Inc.)
- ENCOAL Corporation (ENCOAL® Mild Coal Gasification Project) 3-128
- Energy and Environmental Research Corporation (Enhancing the Use of Coals by Gas Reburning and Sorbent Injection) 3-76
- Energy and Environmental Research Corporation (Evaluation of Gas Reburning and Low-NO_x Burners on a Wall-Fired Boiler) 3-46
- Great River Energy (Lignite Fuel Enhancement) 2-34
- JEA (JEA Large-Scale CFB Combustion Demonstration Project) 2-24
- Kentucky Pioneer Energy, LLC (Kentucky Pioneer Energy IGCC Demonstration Project) 2-28
- LIFAC-North America (LIFAC Sorbent Injection Desulfurization Demonstration Project) 3-20
- NeuCo, Inc. (Demonstration of Integrated Optimization Software at the Baldwin Energy Complex) 2-18
- New York State Electric & Gas Corporation (Micronized Coal Reburning Demonstration for NO_x Control) 3-50
- New York State Electric & Gas Corporation (Milliken Clean Coal Technology Demonstration Project) 3-80
- Ohio Power Company, The (Tidd PFBC Demonstration Project) 3-90

Otter Tail Power Company (Demonstration of a Full-Scale Retrofit of the Advanced Hybrid Particulate Collector Technology) 2-14

Passamaquoddy Tribe (Cement Kiln Flue Gas Recovery Scrubber) 3-142

Public Service Company of Colorado (Integrated Dry NO_x/SO₂ Emissions Control System) 3-84

Pure Air on the Lake, L.P. (Advanced Flue Gas Desulfurization Demonstration Project) 3-24

Sierra Pacific Power Company (Piñon Pine IGCC Power Project) 3-100

Southern Company Services, Inc. (180-MWe Demonstration of Advanced Tangentially Fired Combustion Techniques for the Reduction of NO_x Emissions from Coal-Fired Boilers) 3-58

Southern Company Services, Inc. (Demonstration of Advanced Combustion Techniques for a Wall-Fired Boiler) 3-34

Southern Company Services, Inc. (Demonstration of Innovative Applications of Technology for the CT-121 FGD Process) 3-28

Southern Company Services, Inc. (Demonstration of Selective Catalytic Reduction Technology for the Control of NO_x Emissions from High-Sulfur, Coal-Fired Boilers) 3-54

Sunflower Electric Power Corporation (Achieving NSPS Emission Standards Through Integration of Low-NO_x Burners with an Optimization Plan for Boiler Combustion) 2-8

Tampa Electric Company (Tampa Electric Integrated Gasification Combined-Cycle Project) 3-104

Tampa Electric Company (Big Bend Power Station Neural Network-Sootblower Optimization) 2-16

ThermoChem, Inc. (Pulse Combustor Design Qualification Test) 3-146

TIAX, LLC (Clean Coal Diesel Demonstration Project) 2-30

TIAX, LLC (Development of Hybrid FLGR/SNCR/SCR Advanced NO_x Control) 2-10

Tri-State Generation and Transmission Association, Inc. (Nucla CFB Demonstration Project) 3-94

Universal Aggregates, LLC (Commercial Demonstration of the Manufactured Aggregate Processing Technology Utilizing Spray Dryer Ash) 2-46

University of Kentucky Research Foundation (Advanced Multi-Product Coal Utilization By-Product Processing Plant) 2-48

Wabash River Coal Gasification Repowering Project Joint Venture (Wabash River Coal Gasification Repowering Project) 3-108

Western Greenbrier Co-Generation, LLC (Western Greenbrier Co-Production Demonstration Project) 2-50

Western SynCoal LLC (Advanced Coal Conversion Process Demonstration) 2-38

Wisconsin Electric Power Company (TOXECON Retrofit for Mercury and Multi-Pollutant Control on Three 90 MW Coal-Fired Boilers) 2-20

WMPI PTY., LLC (Gilberton Coal-to-Clean Fuels and Power Co-Production Project) 2-36

1. Clean Coal Demonstration Projects

Introduction

This report provides fact sheets on active and completed clean coal technology (CCT) projects in three U.S. Department of Energy demonstration programs—Clean Coal Technology Demonstration Program (CCTDP), Power Plant Improvement Initiative (PPII), and Clean Coal Power Initiative (CCPI).

The CCTDP, PPII, and CCPI project fact sheets are organized by active projects and completed projects. Within each of these categories, the projects are further organized by market sector rather than program to better enable stakeholders to see the scope of activity in key areas of interest. These market sectors are: (1) environmental control devices for existing and new power plants; (2) advanced electric power generation for repowering existing plants and providing new generation capacity; (3) coal processing for clean fuels to convert the nation's vast coal resources to clean fuels; and (4) industrial applications for coal and coal by-products.

Fact sheets present available project information in two pages or four pages depending on project status. The two-page fact sheets are for projects that have not completed operations. The fact sheets include information on project participants, describe the projects and technology, lay out planned schedules, characterize project status and accomplishments; and address potential commercial applications. The four-page fact sheets are used for projects having completed operations. In place of characterizing project status and accomplishments, the four-page fact sheets provide key findings and sufficient project discussion to establish a context for the findings. Projects are not considered complete and information final, however, until issuance of the final technical report.

All project fact sheets contain schematics of the demonstrated technology to help convey understanding. The portion of the process or facility central to the demonstration is demarcated by a shaded area. To prevent the release of project-specific information of a proprietary nature, the schematics are highly simplified to illustrate the concept only.

2. Active Projects

Introduction

The following overviews some of the major technology areas and underlying drivers that are the current focus of the active CCTDP, PPII, and CCPI projects.

Environmental Control Devices

Advanced NO_x Controls. Advanced nitrogen oxide (NO_x) controls provide the means to meet NO_x emission caps proposed under the Clear Skies Initiative (CSI); EPA's "SIP Call" source emission rates of 0.15 lb/10⁶ Btu for 22 states and the District of Columbia; and revised National Ambient Air Quality Standards (NAAQS) for ozone and fine particulate matter (PM_{2.5}), which impacts NO_x because it is a precursor to both. Technologies include:

- Low-NO_x burners and reburning systems that limit NO_x formation by staging the introduction of air in the combustion process (combustion modification);
- Selective catalytic reduction (SCR), and selective non-catalytic reduction (SNCR), and other chemical processes that act upon and reduce NO_x already formed (post-combustion processes); and
- Oxygen-enhanced combustion that displaces a portion of the air with oxygen in low-NO_x burners.

Low-NO_x burners (1) limit the amount of air available in the initial stages of combustion when fuel-bound nitrogen is volatilized, (2) lengthen the flame to avoid hot spots, (3) are integrated with overfire air to complete combustion in a cooler zone, and (4) leverage neural network controls for optimum load-following performance. Reburning systems inject fuel into combustion products to strip oxygen away from the NO_x and introduce overfire air to complete combustion. SCR and SNCR use ammonia/urea to transform NO_x into nitrogen and water. SCR

typically requires an array of catalysts in a reactor vessel to operate at post-boiler application temperatures, whereas SNCR simply involves ammonia/urea injection in the boiler. Oxygen-enhanced combustion enables deeper staging through increased combustion efficiency and reduces available nitrogen.

Mercury Controls. Mercury controls address proposed CSI targets and anticipated EPA regulations regarding mercury emissions from coal-based power generation, which represents roughly one-third of U.S. mercury emissions. Technologies include:

- Sorbents and oxidizing agents to transform mercury to a solid for removal along with fly ash in electrostatic precipitators (ESP) or fabric filter dust collectors (FFDC);
- Oxidizing agents in conjunction with wet flue gas desulfurization (FGD) scrubbers to capture mercury in the sulfate by-products; and
- Real-time measurement of mercury species and total mercury for mercury control and validation.

Solid sorbents adsorb the mercury and are then removed in either an electrostatic precipitator (ESP) or fabric filter dust collector (FFDC). Oxidizing agents or mechanisms convert vapor-state elemental mercury to a solid-state mercury oxide that can be captured in ESPs, FFDCs, or wet FGDs. For plants equipped with wet FGDs, the oxidizing agent can be incorporated with the scrubber slurry used for sulfur capture. The mercury captured in the FGD by-product, often wallboard, is chemically bound and precluded from re-release. Mercury instrumentation and controls measure the mercury species (elemental and oxidized) entering the control device and the total mercury entering the stack.

Particulate Matter Controls. Particulate-matter controls respond to revised NAAQS for PM_{2.5} for primary particulate matter (fly ash) and acid aerosols that can cause localized plume opacity, visibility impairment, and have been linked to human health impacts. Acid aerosols are

required to be reported under the Toxic Release Inventory. Secondary PM_{2.5} emissions, formed chemically in the atmosphere by precursors such as NO_x and SO₂, are addressed under Advanced NO_x Control. Technologies include:

- ESP/FFDC hybrids to leverage the best features of both;
- Flue gas preconditioning to enhance ESP performance;
- Concentration of particulate matter at ESP outlets for recycle;
- Alkaline injection for sulfur trioxide (SO₃) acid aerosol precursor control; and
- Continuous SO₃ analyzers for process control and validation.

ESPs electrically charge particulate matter for capture on collection plates. FFDCs use fabric filter bags that receive and collect particulate matter on the outside surface and are pulsed internally with jets of air to disengage the collected particulate. Preconditioning agents either lower resistivity or induce agglomeration of incoming particulate matter. Alkaline injection converts SO₂ and SO₃ acid precursors into readily captured sulfate particulate and neutralizes other acid gases, such as hydrochloric and hydrofluoric acids. The SO₃ analyzers measure input and output levels for control and validation.

Advanced Electric Power Generation

Advanced Power Systems. Advanced electric power generation addresses Global Climate Change, Clear Skies, and Hydrogen Production initiatives by enhancing power generation efficiency, producing near zero pollutant emissions, and providing for hydrogen separation and carbon dioxide (CO₂) capture and sequestration. Technologies include:

- Integrated gasification combined-cycle (IGCC) systems that: convert coal to a clean synthesis gas (syngas) amenable to use by gas turbines and advanced fuel cells, conversion to chemicals and clean transportation fuels, and separation into hydrogen and CO₂; and transform residual gases and solids into salable by-products.
- Circulating fluidized-bed (CFB) combustion systems that utilize low-grade fuels and waste materials to generate power at high efficiency and with very low emissions, without the parasitic power drain of add-on environmental controls.

IGCC uses a gasifier to convert hydrocarbon feedstocks into largely gaseous components by applying heat under pressure in the presence of steam. Partial oxidation of the feedstock, typically with pure oxygen, provides the heat. Together the heat and pressure break the bonds between feedstock constituents and precipitate chemical reactions, producing syngas—primarily hydrogen and carbon monoxide. Minerals in the feedstock (ash), separated in the gasifier, are largely salable. Sulfur emerges from the gasifier primarily as hydrogen sulfide, which is easily converted to either a pure sulfur or sulfuric acid by-product.

The CFBs use jets of air to support combustion, effectively mix feedstocks with sulfur dioxide (SO₂) absorbents, and entrain the mixture. The entrained mixture is transported to a cyclone that separates the solids from the flue gas. Hot separated solids are returned to the CFB combustor. Relatively clean flue gas goes to a heat exchanger to produce steam for a steam turbine. The mixing and recycling action of the CFB allows high combustion efficiency at temperatures below the thermal NO_x formation temperature and achieves high-efficiency SO₂ capture through lengthy and direct sorbent/SO₂ contact.

Coal Processing for Clean Fuels

Coal liquefaction. Coal liquefaction enhances energy security by converting our nation's most abundant, stable priced energy resource into clean transportation fuels and chemicals. Coal gasification-derived syngas is converted into synthetic hydrocarbon liquids via a catalytic chemical process known as Fischer Tropsch (FT) synthesis. The FT

process can be manipulated to produce an array of products that are virtually free of sulfur and nitrogen pollutants.

Industrial Applications

Coal Utilization By-Products (CUB). CUBs efforts provide the knowledge and technology needed to increase utilization of CUBs from the current 30 percent usage to 50 percent. Landfill space is limited, and NO_x and mercury controls impact CUB quality and raise questions regarding environmental acceptability. Technology and knowledge targets include:

- Characterizing the fate of mercury and other trace metals in CUBs;
- Novel applications to expand CUB use; and
- Separation technology to remove carbon and associated mercury from CUBs to enhance sales value.

CUB characterization addresses what happens to the mercury and other trace elements contained in the CUBs when used in various applications (*i.e.*, the potential for leaching or volatilization). Novel applications include use as construction and structural materials and agricultural supplements. Separation technologies use physical and chemical processes adopted from coal beneficiation practices.

Active Project Fact Sheets

An index to the active project fact sheets by application category is provided in Exhibit 2-1. An index by participant is provided in Exhibit 2-2. Ongoing projects in each category appear first, followed by projects having completed operations, but not reporting. Within these breakdowns, projects are listed alphabetically by participant. In addition, Exhibit 2-1 indicates the solicitation under which the project was selected; its status as of May 31, 2003; and the page number for each fact sheet. Exhibit 2-2 lists the projects alphabetically by participant and provides project location and page numbers. A key to interpreting the milestone charts is provided in Exhibit 2-3.

Exhibit 2-1
Active Project Fact Sheets by Application Category

Project	Participant	Solicitation/Status	Page
Environmental Control Devices			
Achieving NSPS Emission Standards Through Integration of Low-NO _x Burners with an Optimization Plan for Boiler Combustion	Sunflower Electric Power Corporation	PPII/design	2-8
Development of Hybrid FLGR/SNCR/SCR Advanced NO _x Control	TIAX, LLC	PPII/negotiation	2-10
Greenidge Multi-Pollutant Control Project	CONSOL Energy, Inc.	PPII/negotiation	2-12
Demonstration of a Full-Scale Retrofit of the Advanced Hybrid Particulate Collector Technology	Otter Tail Power Company	PPII/operational	2-14
Big Bend Power Station Neural Network-Sootblower Optimization	Tampa Electric Company	PPII/construction	2-16
Demonstration of Integrated Optimization Software at the Baldwin Energy Complex	NeuCo, Inc.	CCPI-I/negotiation	2-18
TOXECON Retrofit for Mercury and Multi-Pollutant Control on Three 90 MW Coal-Fired Boilers	Wisconsin Electric Power Company	CCPI-I/negotiation	2-20
Advanced Electric Power Generation			
JEA Large-Scale CFB Combustion Demonstration Project	JEA	CCTDP-I/operational	2-24
Next Generation CFB Coal Generating Unit	Colorado Springs Utilities	CCPI-I/negotiation	2-26
Kentucky Pioneer Energy IGCC Demonstration Project	Kentucky Pioneer Energy, LLC	CCTDP-V/design	2-28
Clean Coal Diesel Demonstration Project	TIAX, LLC	CCTDP-V/design	2-30
Coal Processing for Clean Fuels			
Lignite Fuel Enhancement	Great River Energy	CCPI-I/negotiation	2-34
Gilberton Coal-to-Clean Fuels and Power Co-Production Project	WMPI PTY., LLC	CCPI-I/negotiation	2-36
Advanced Coal Conversion Process Demonstration	Western Syncoal LLC	CCTDP-I/reporting	2-38
Industrial Applications			
Clean Power from Integrated Coal/Ore Reduction (CPICOR™)	CPICOR™ Management Company LLC	CCTDP-V/design	2-44
Commercial Demonstration of the Manufactured Aggregate Processing Technology Utilizing Spray Dryer Ash	Universal Aggregates, LLC	PPII/construction	2-46
Advanced Multi-Product Coal Utilization By-Product Processing Plant	University of Kentucky Research Foundation	CCPI-I/negotiation	2-48
Western Greenbrier Co-Production Demonstration Project	Western Greenbrier Co-Generation, LLC	CCPI-I/negotiation	2-50

Exhibit 2-2

Active Project Fact Sheets by Participant

Participant	Project	Location	Page
Colorado Springs Utilities	Next Generation CFB Coal Generating Unit	Fountain, CO	2-26
CONSOL Energy, Inc.	Greenidge Multi-Pollutant Control Project	Torrey, NY	2-12
CPICOR™ Management Company LLC	Clean Power from Integrated Coal/Ore Reduction (CPICOR™)	Vineyard, UT	2-44
Great River Energy	Lignite Fuel Enhancement	Underwood, ND	2-34
JEA	JEA Large-Scale CFB Combustion Demonstration Project	Jacksonville, FL	2-24
Kentucky Pioneer Energy, LLC	Kentucky Pioneer Energy IGCC Demonstration Project	Trapp, KY	2-28
NeuCo, Inc.	Demonstration of Integrated Optimization Software at the Baldwin Energy Complex	Baldwin, IL	2-18
Otter Tail Power Company	Demonstration of a Full-Scale Retrofit of the Advanced Hybrid Particulate Collector Technology	Big Stone City, SD	2-14
Sunflower Electric Power Corporation	Achieving NSPS Emission Standards Through Integration of Low-NO _x Burners with an Optimization Plan for Boiler Combustion	Garden City, KS	2-8
Tampa Electric Company	Big Bend Power Station Neural Network-Sootblower Optimization	Apollo Beach, FL	2-16
TIAX, LLC	Clean Coal Diesel Demonstration Project	Fairbanks, AK	2-30
TIAX, LLC	Development of Hybrid FLGR/SNCR/SCR Advanced NO _x Control	TBD	2-10
Universal Aggregates, LLC	Commercial Demonstration of the Manufactured Aggregate Processing Technology Utilizing Spray Dryer Ash	King George Co., VA	2-46
University of Kentucky Research Foundation	Advanced Multi-Product Coal Utilization By-Product Processing Plant	Ghent, KY	2-48
Western Greenbrier Co-Generation, LLC	Western Greenbrier Co-Production Demonstration Project	Rainelle, WV	2-50
Western SynCoal LLC	Advanced Coal Conversion Process Demonstration	Colstrip, MT	2-38
Wisconsin Electric Power Company	TOXECON Retrofit for Mercury and Multi-Pollutant Control on Three 90 MW Coal-Fired Boilers	Marquette, MI	2-20
WMPI PTY., LLC	Gilberton Coal-to-Clean Fuels and Power Co-Production Project	Gilberton, PA	2-36

Exhibit 2-3

Key to Milestone Charts in Project Fact Sheets

Each fact sheet contains a bar chart that highlights major milestones—past and planned. The bar chart shows a project’s duration and indicates the time period for three general categories of project activities—preaward, design and construction, and operation and reporting. The key provided below explains what is included in each of these categories.

 **Preaward**

Includes preaward briefings, negotiations, and other activities conducted during the period between DOE’s selection of the project and award of the cooperative agreement.

 **Design and Construction**

Includes the NEPA process, permitting, design, procurement, construction, preoperational testing, and other activities conducted prior to the beginning of operation of the demonstration.

MTF Memo-to-file

CX Categorical exclusion

EA Environmental assessment

EIS Environmental impact statement

 **Operation and Reporting**

Begins with startup and includes operational testing, data collection, analysis, evaluation, reporting, and other activities to complete the demonstration project.

Environmental Control Devices

Achieving NSPS Emission Standards Through Integration of Low-NO_x Burners with an Optimization Plan for Boiler Combustion

Participant

Sunflower Electric Power Corporation

Additional Team Members

Electric Power Research Institute—cofunder

Foster Wheeler Energy Corporation—technology supplier

GE Energy and Environmental Research Corp.—
 technology supplier

Location

Garden City, Finney County, KS (Sunflower Electric's
 Holcomb Station, Unit No. 1)

Technology

Ultra-low NO_x burners with other combustion-stage
 controls

Plant Capacity/Production

360 MW

Coal

Subbituminous coals

Project Funding

Total	\$5,881,675	100%
DOE	2,796,326	48
Participant	3,085,349	52

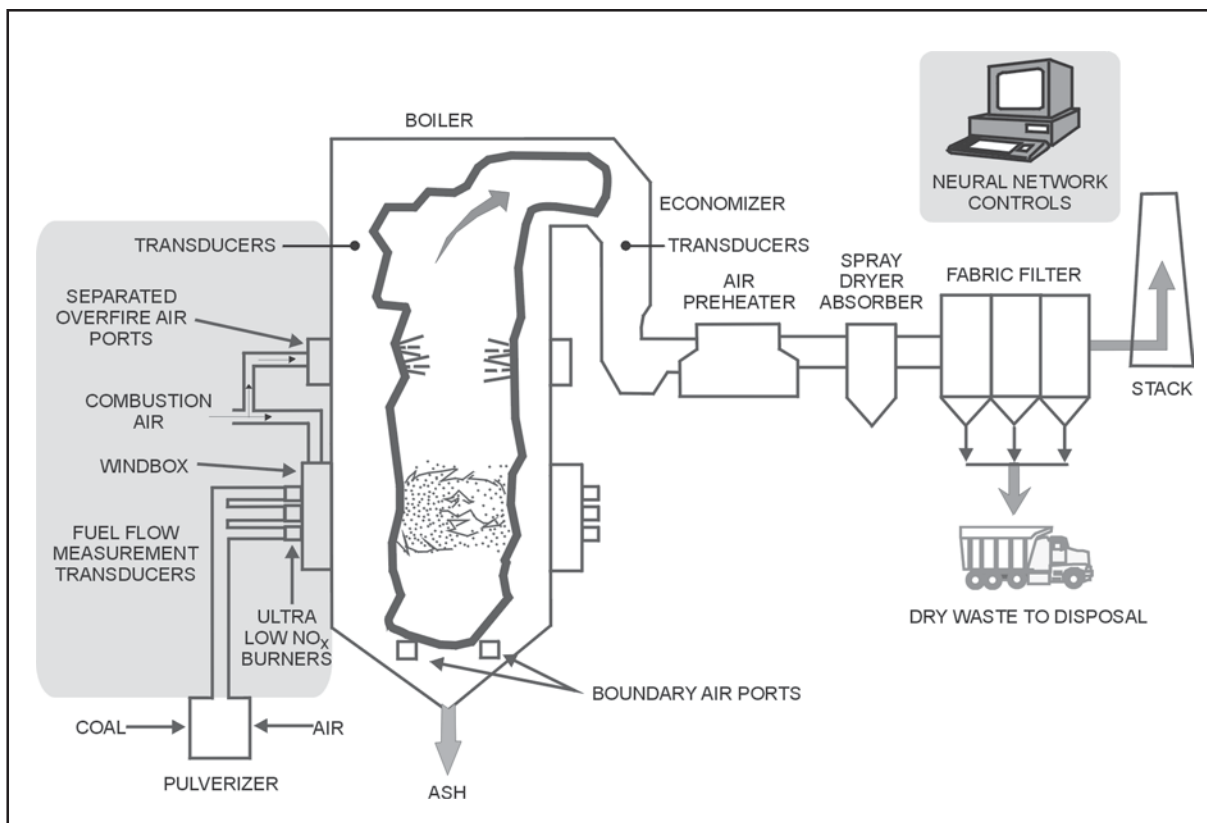

Project Objective

To demonstrate low-NO_x burners with other combustion-stage controls with the goal to reduce NO_x emissions to 0.15–0.22 lb/10⁶ Btu and simultaneously increase power output by 7 MW, demonstrating a concept that has never been illustrated in plants using subbituminous coals, including those from the Powder River Basin (PRB).

Technology/Project Description

Low-NO_x Burners (LNB) have been in development since the late 1970s and are in general use on many steam-electric generating units. Increasing demands for overall reductions in NO_x emissions have continued to put pressure on manufacturers to improve burner design. The existing low-NO_x burners were modified. When used with separated overfire air (SOFA) they have been found capable of reducing emission rates to very near the cur-

rent New Source Performance Standards (NSPS) level of 0.15 lb/10⁶ Btu.

To further reduce NO_x emissions, the participant will employ five elements: (1) low NO_x burners, (2) separated overfire air, (3) fuel flow measurement transducers, (4) fuel/air balancing, and (5) advanced network controls.

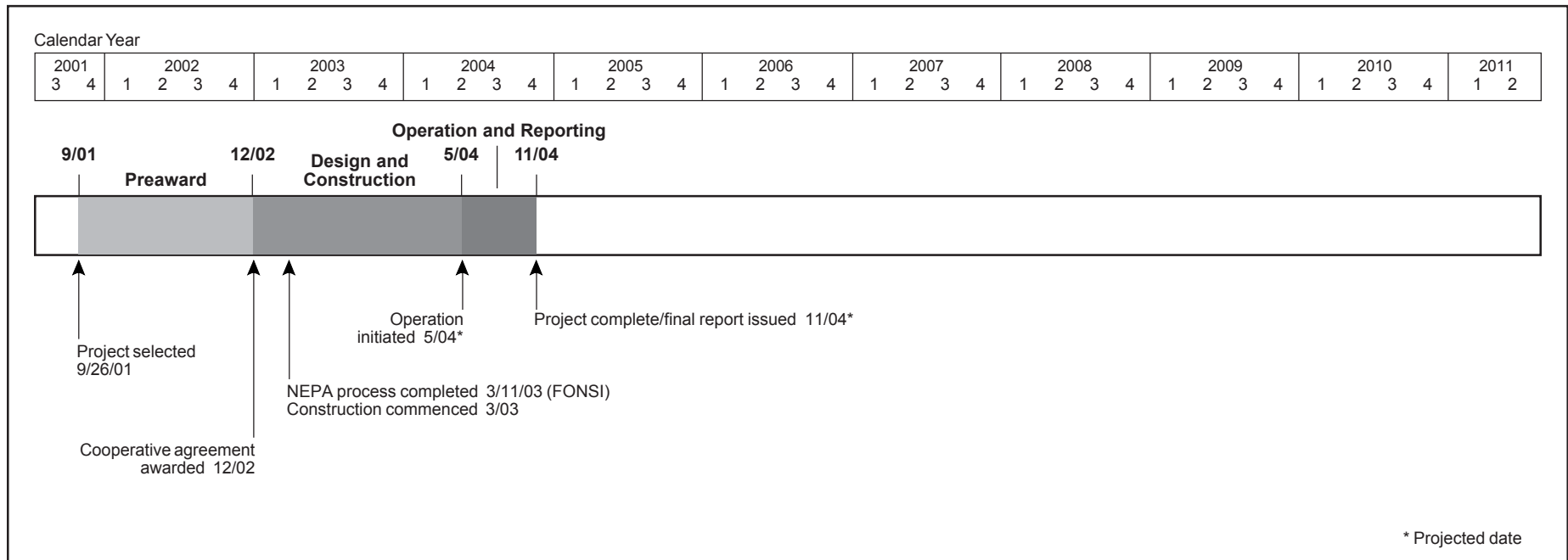

Project Status/Accomplishments

The project was selected for award on September 26, 2001. The cooperative agreement was awarded on December 17, 2002. DOE issued the Environmental Assessment in March 2003 and signed the Finding of No Significant Impact (FONSI) on March 11, 2003. Construction began immediately and some of the equipment is already in place.

The full application of the five elements proposed herein have never been demonstrated in plants firing subbituminous coals, especially those from Wyoming's PRB. Likewise, there are no other wall-fired units on which owners have sought to fully explore the technology proposed to its fullest potential. The inclusion of the very latest in distributed control systems, proposed for this unit in 2003, make this location ideal for integration with the proposed elements. The unit on which this technology will be applied has among the very best availabilities and performance histories for boilers of its type. It was placed in commercial operation in 1983 and is equipped with the latest SO₂ scrubber and fabric filter for particulate matter. When completed, this will be among the cleanest non-

SCR-equipped coal-fired units in the United States. The Sunflower LNB/SOFA integrated system would be installed in three distinct phases to demonstrate the synergistic effect of layering NO_x control technologies.

Phase I, Advanced Monitoring/Coal Flow Measurement, would demonstrate the effectiveness of control upgrades with respect to NO_x control and thermal efficiency, with minimal impact from physical modification of the boiler. During this phase, instruments capable of measuring coal flow within individual coal conduits would be installed. Limited changes would be made to the plants' computing and control systems.

Phase II, Low-NO_x Burner Modifications/Coal Flow Control, would demonstrate the effectiveness of low-cost modifications to the existing, first-generation low-NO_x burners for the reduction of NO_x emissions. Modifications to the existing pulverizer classifiers would permit automated fuel balancing among all burners and would include the installation of new burner tips and a better means of controlling air flow on individual burners.

Phase III, Advanced Overfire Air/DCS Integration, would demonstrate deeper NO_x control competitive to SCR in-

stallation with the addition of an overfire air system that would be coupled with the existing Phase I and II modifications to optimize system performance. Final combustion control integration with a new combustion control system (a contemporaneous improvement not included as a part of this project) would maximize potential NO_x reductions.

Commercial Applications

There are as many as 30 units for which this technology can be deployed that will be able to meet the current NSPS level. A further 60 units will be able to establish significant reductions, to levels of about 0.22 lb/10⁶ Btu. This choice of equipment, if enabled in a timely fashion, will allow a reduction in the number of SCRs being installed, thereby reducing the overall consumer cost; will reduce the outage duration necessary for completion, thereby improving the electric system reliability; and will conserve the critical pool of skilled labor needed to accomplish this work.

Development of Hybrid FLGR/ SNCR/SCR Advanced NO_x Control

Participant

TIAX, LLC (acquired the research contracts of Arthur D. Little, Inc.)

Additional Team Members

Fuel Tech—equipment supplier

Location

To be determined

Technology

A hybrid of Fuel-Lean Gas Reburn/Selective Non-Catalytic Reduction, and Selective Catalytic Reduction

Plant Capacity/Production

To be determined

Coal

Eastern Bituminous Coal

Project Funding

Total	\$30,513,711	100%
DOE	14,957,658	49
Participant	15,556,053	51

Project Objective

To develop and demonstrate a hybrid system composed of lower-cost components from three established NO_x-reduction systems that can function as stand-alone units or as an integrated, optimized, single-control system. Using Fuel-Lean Gas Reburn/Selective Non-Catalytic Reduction (FLGR/SNCR), Selective Non-Catalytic Reduction (SNCR), and Selective Catalytic Reduction (SCR) systems, the hybrid seeks to lower NO_x emissions to 0.15 lb/10⁶ Btu at lower costs than conventional SCR, a comparatively expensive, effective way to curb NO_x.

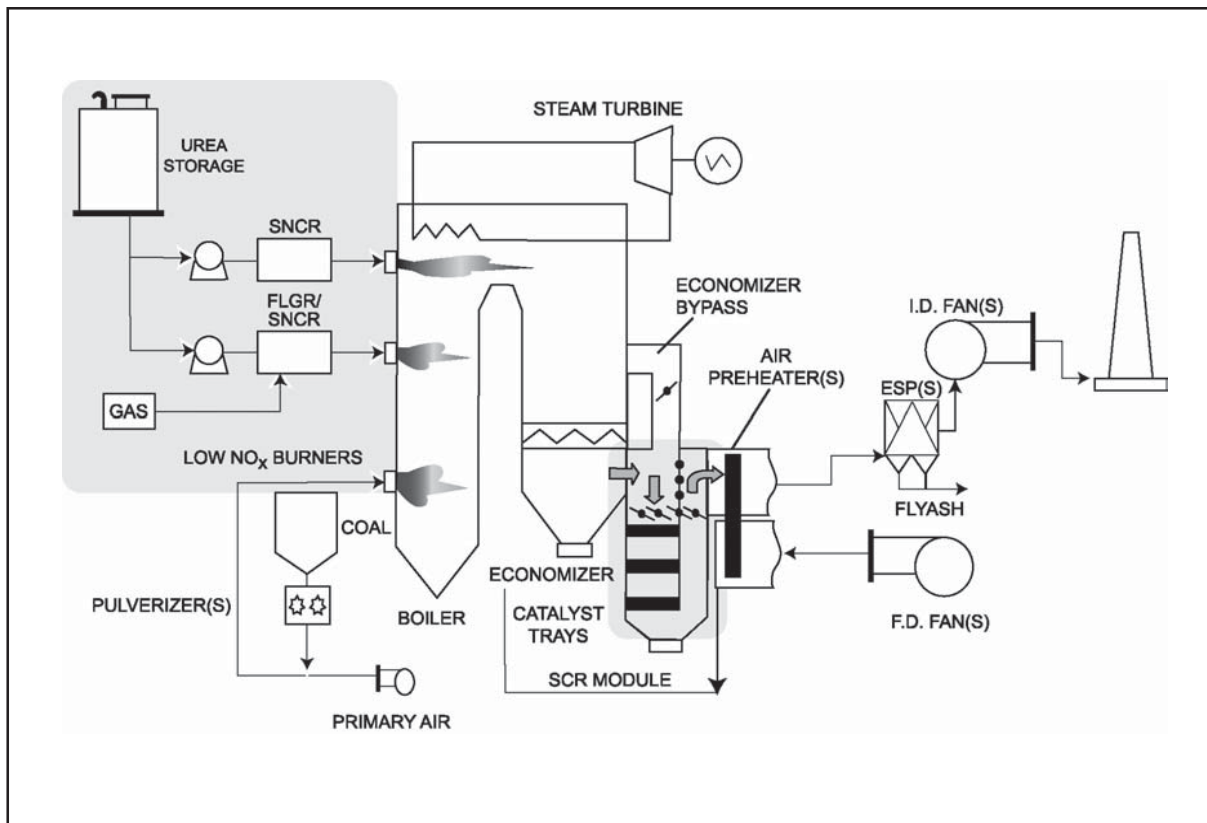

Technology/Project Description

The three components in the hybrid system are FLGR/SNCR, SNCR, and compact SCR. They have been developed individually, but have not been developed and optimized as a hybrid control system. The objectives of this project are to demonstrate the hybrid system as a lower cost alternative to SCR to achieve 0.15 lb/10⁶ Btu emission levels, and to operate the hybrid system to improve performance and reduce compliance costs to enhance operation in system-wide dispatch in the deregulated market.

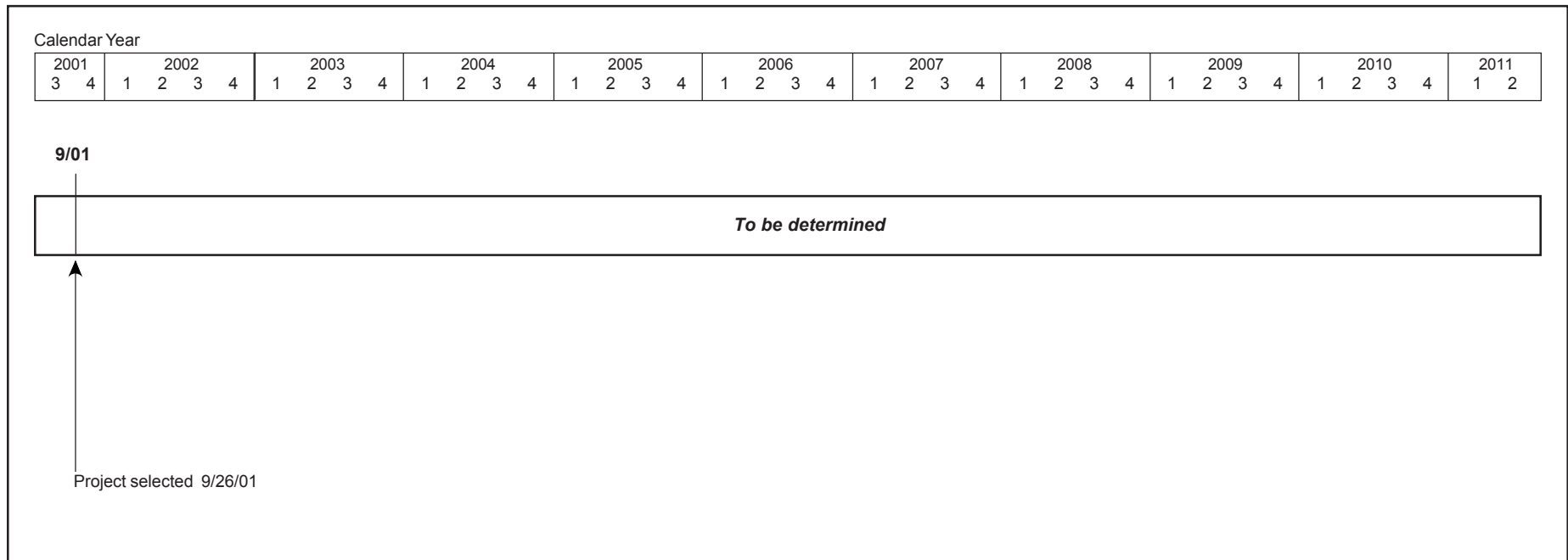

Project Status/Accomplishments

The project was selected for award on September 26, 2001. Originally, Orion Power’s Avon Lake Unit No. 9 near Cleveland, Ohio, was to be the host site. However, in February 2002, Orion Power was bought out by Reliant Energy, which decided in April 2002 not to pursue the project. TIAX, LLC, which acquired the research contracts of Arthur D. Little, Inc. (ADL) during ADL’s bankruptcy proceedings in early 2002, has identified other potential sites and is proceeding to develop revised cost estimates. The schedule will be finalized when a new site is selected and the cooperative agreement is signed.

Commercial Applications

Coal-fired power boiler operators are facing a dual challenge to remain competitive while adapting to deregulation and to impending stringent NO_x controls. The NO_x control technologies available to coal-fired operators are not optimized for this new set of challenges. Under deregulation, the optimum control techniques need to have a low capital cost and cost-effective NO_x reduction over a wide operational range so that the performance of each unit in the system can be optimized to allow maximum

revenue dispatch. The increased flexibility is needed to allow each boiler and the integrated system to respond competitively to market conditions. Current reliance on selective catalytic reduction, with the associated high capital cost, will not typically give a utility sufficient dispatch flexibility to maximize competitiveness. Projections indicate that 30% of coal-fired boilers are going to be retrofitted with SCR. For the balance of units, power generators are looking for lower cost, more flexible means to design their units for competitive dispatch dictated by regional cost and environmental criteria.

Greenidge Multi-Pollutant Control Project

Participant

CONSOL Energy, Inc.

Additional Team Members

AES Greenidge, LLC—host

Environmental Elements Corporation (EEC)—technology supplier

Foster Wheeler Energy Corporation (FWEC)—technology supplier

AEP Pro Serv—construction coordinator

Location

Torrey, Yates County, NY (AES' Greenidge Unit No. 4)

Technology

Single-bed Selective Catalytic Reduction in combination with low-NO_x combustion technology to control NO_x and a circulating dry scrubber with carbon injection to control SO₂, mercury, and acid gases

Plant Capacity/Production

104 MW

Coal

Bituminous coal (<2% sulfur) co-fired with up to 10% biomass

Project Funding

Total	\$32,800,000	100%
DOE	14,500,000	44
Participant	18,300,000	56

Project Objective

To demonstrate a multi-pollutant-control system that can cost effectively reduce NO_x, SO₂, acidic gas, and mercury from smaller coal plants. This project would be the first to demonstrate (1) NO_x reductions to 0.122 lb/10⁶ Btu using single bed, in-duct Selective Catalytic Reduction (SCR)

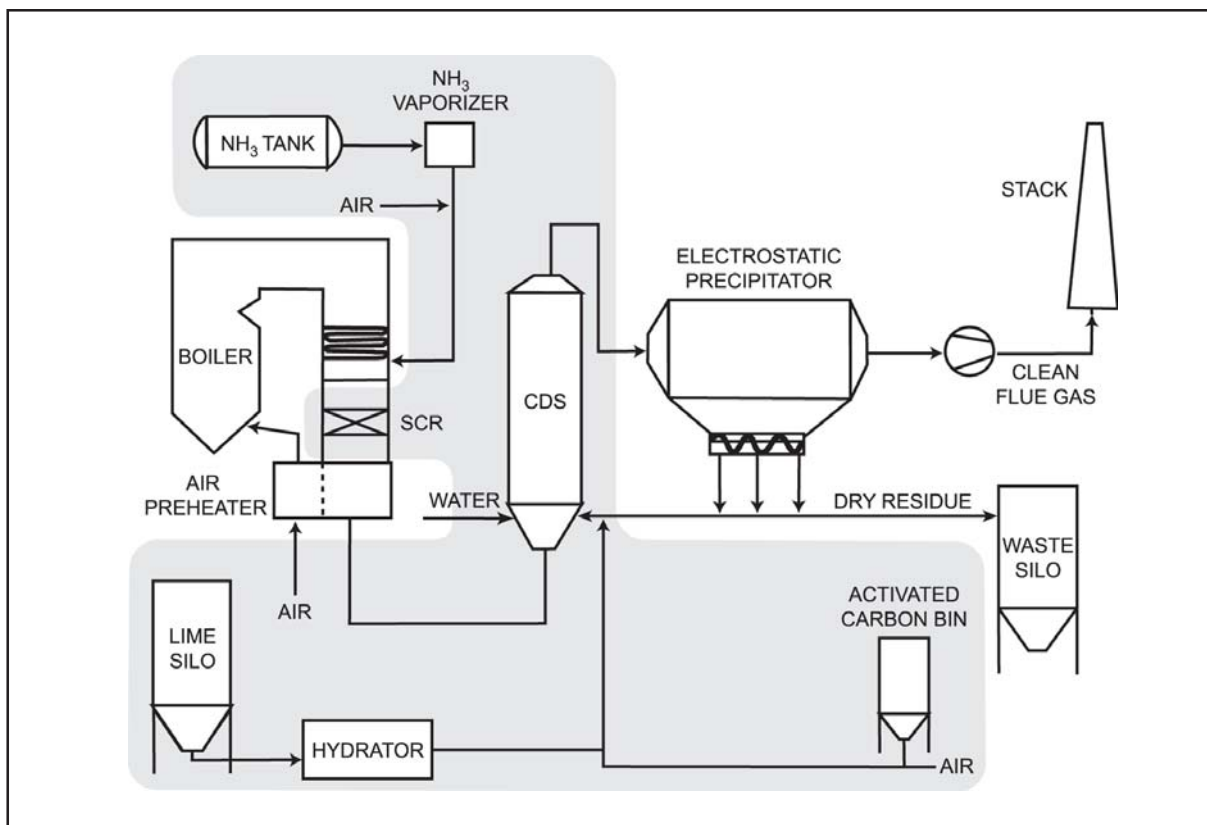

combined with a low-NO_x combustion technology on a unit burning coal and biomass, (2) 95% SO₂ removal using a Circulating Dry Scrubber (CDS) from Environmental Elements Corp. on a coal-fired boiler, (3) 90% mercury reduction in the CDS, and (4) more than 95% acid gas (sulfur trioxide (SO₃), hydrochloric (HCl), and hydrofluoric (HF) acids) removal in the CDS.

Technology/Project Description

The single-bed, in-duct SCR, in combination with low-NO_x combustion technology, can achieve 60% NO_x reduction for about one-third the capital cost and one-fourth the operating and maintenance cost of a full SCR or Selective Non-Catalytic Reduction (SNCR) system on a 104-MW unit. The capital cost of the CDS system is projected to be less than half that of a conventional flue gas desulfurization (FGD) system. Operating and maintenance costs are less for the CDS system. Activated carbon injected

into the CDS unit is projected to use 5 to 10 times less carbon than direct injection into the flue gas duct for a given level of mercury control, because the carbon has a greater average contact time in the CDS bed than in the flue gas duct. Reducing the carbon feed rate results in substantial mercury control cost savings. The CDS system will reduce acid gases (SO₃, HCl, HF) by more than 95%, with the additional benefits of reducing plume visibility and secondary particulate formation. Acid gases must be reported to EPA as part of the Toxic Release Inventory (TRI). The project will also include an evaluation of the impact of biomass co-firing (5–10% of the heat input) on the performance of the SCR and CDS systems.

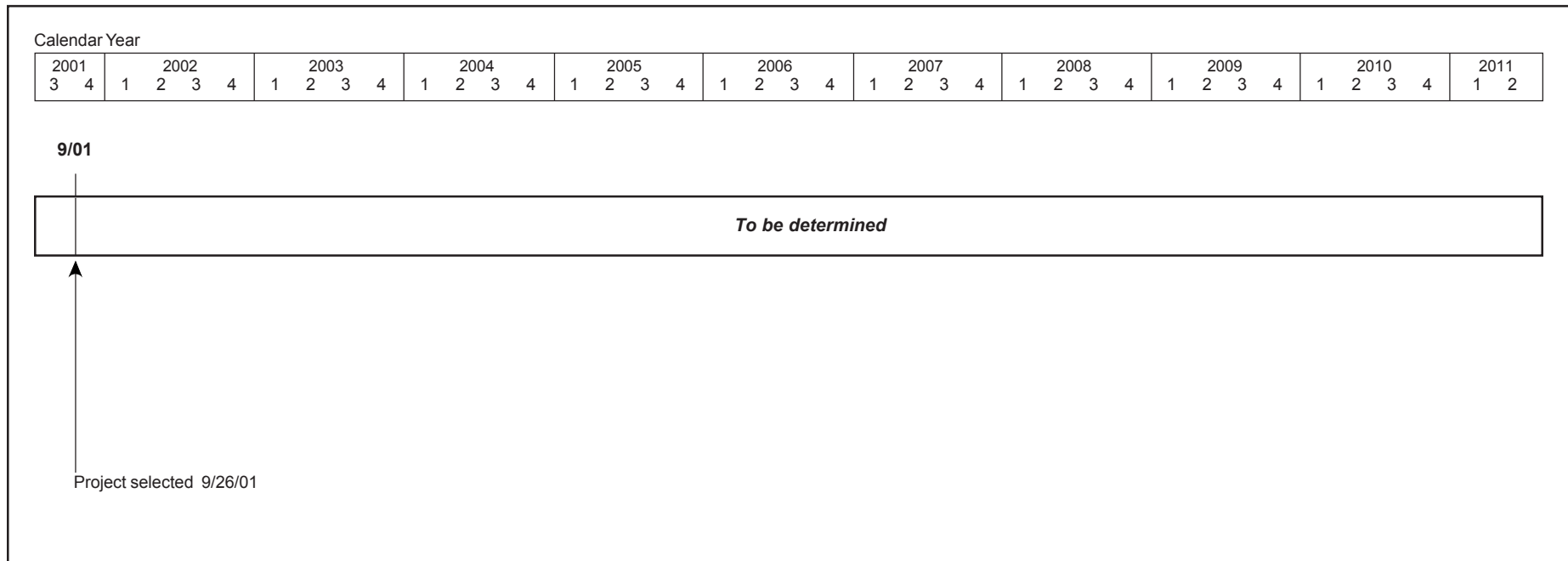

Project Status/Accomplishments

The project was selected for award on September 26, 2001. Contract negotiations are continuing. The schedule will be finalized when contract negotiations are complete.

The goal of the proposed project is to demonstrate substantial improvements in mercury, SO₃ and fine particulate control, and substantial reductions in the cost for NO_x and SO₂ control, compared to conventional technologies when applied to the large number of smaller coal-fired generating units in the U.S. This project will produce operating and maintenance cost data, reliability and availability data, and process performance data so that generators will accept the risk of installing multi-pollutant control on smaller coal-fired units. Ultimately, the successful demonstration of these technologies will help to ensure the future availability of low-cost electricity from a significant fraction of the U.S. coal-fired generating fleet.

Commercial Applications

Greenidge Unit No. 4 is representative of 492 coal-fired electricity generating units in the United States with capacities of 50–300 MWe. These smaller units, almost one

quarter of the U.S. coal-fired generating capacity, are increasingly vulnerable to fuel switching or retirement as a result of more stringent state and federal environmental regulations. The proposed project will demonstrate the commercial readiness of an emissions control system that is particularly suited, because of its low capital and maintenance costs, to meet the requirements of this large group of smaller existing electricity generating units.

Demonstration of a Full-Scale Retrofit of the Advanced Hybrid Particulate Collector Technology

Participant

Otter Tail Power Company

Additional Team Members

Montana-Dakota Utilities—co-host

NorthWestern Public Service—co-host

W.L. Gore & Associates, Inc.—licensee and filter bag provider

Energy and Environmental Research Center (University of North Dakota)—concept developer

Location

Big Stone City, Grant County, SD (Montana-Dakota Utilities and NorthWestern Public Service's Big Stone Power Plant)

Technology

Advanced Hybrid™ (formerly known as Advanced Hybrid Particulate Collector)

Plant Capacity/Production

450 MW

Coal

Low-sulfur coal

Project Funding

Total	\$13,353,288	100%
DOE	6,490,585	49
Participant	6,862,703	51

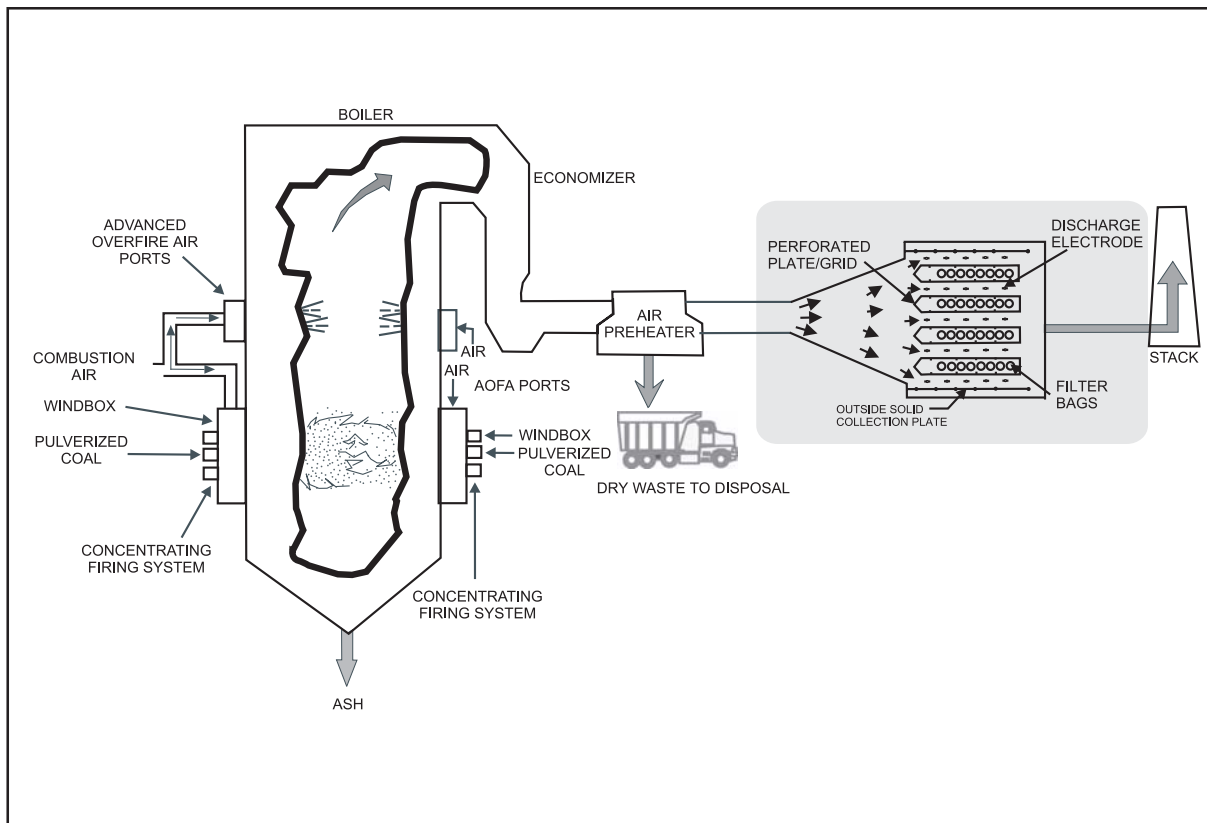

Project Objective

To demonstrate, in a full-scale application, a hybrid technology that raises the particulate matter capture of coal plants up to 99.99% by integrating fabric filtration and electrostatic precipitation (ESP) in a single unit. The Advanced Hybrid™ overcomes the problem of excessive fine particle emissions that escape collection in ESPs and the reentrainment of dust in baghouses. The overall goal of the project is to demonstrate the Advanced Hybrid™ concept in a full-scale application. Specific objectives are to demonstrate ultra-low fine particulate emissions, low pressure drop, overall reliability of the technology and, eventually, long-term bag life.

Technology/Project Description

The Advanced Hybrid™ combines the best features of ESPs and baghouses in an entirely novel manner. The

Advanced Hybrid™ concept combines fabric filtration and electrostatic precipitation in the same housing, providing major synergism between the two methods, both in the particulate collection step and in transfer of dust to the hopper. The Advanced Hybrid™ provides ultra-high collection efficiency, overcoming the problem of excessive fine-particle emissions with conventional ESPs, and solves the problem of reentrainment and re-collection of dust in conventional baghouses.

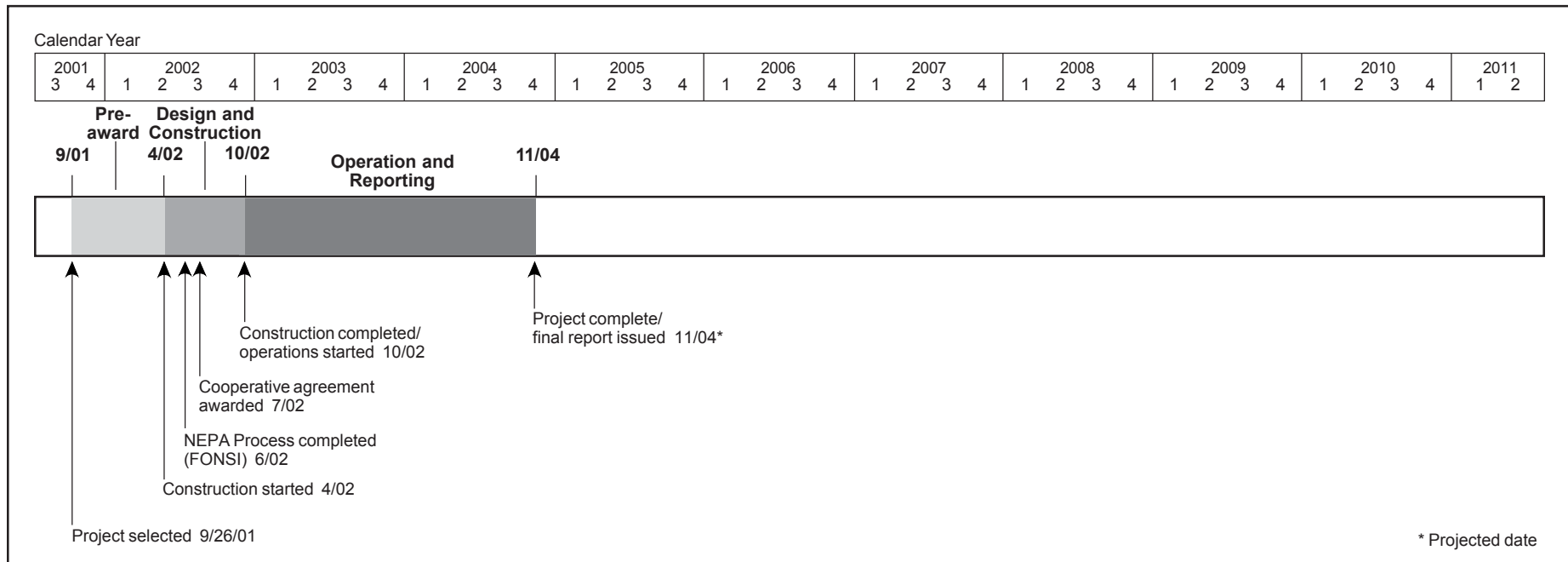

Project Status/Accomplishments

The project was selected for award on September 26, 2001. A cooperative agreement was awarded July 2, 2002. The NEPA process was completed with the issuance of the Environmental Assessment in June 2002 and the FONSI on June 11, 2002. Construction commenced in July 2002 and was completed in October 2002. Start-up was completed on October 25, 2002.

The first six months of operation showed very good particulate removal efficiency, but at a higher than anticipated pressure drop. Performance testing has shown that the average collection efficiency of the Advanced Hybrid™ is 99.997%. The outlet dust loading is almost two orders of magnitude lower than the guarantee limit of 0.002 grains per actual cubic feet. Operations are continuing with the goal of reducing the overall operating cost, including pressure drop.

Commercial Applications

With new requirements to control respirable particulate matter (less than 2.5 microns in diameter; PM_{2.5}), the Advanced Hybrid™ is a superior technology not only for new installations but as a retrofit technology as well. The Advanced Hybrid™ combines a high particulate collection efficiency, with a small footprint and potential economic advantages. Given the age and performance level of many existing ESPs, there is a great and immediate need for this type of retrofit technology. This technology has potential application to all of the more than 1,000 coal-fired units. However, space and other site-specific constraints come in to play to preclude 100% applicability.

The Advanced Hybrid™ is economically competitive with ESPs and baghouses for meeting current standards. For meeting a possible stricter fine-particle standard or 99.99% control of total particulates, the Advanced Hybrid™ is the economic choice over either ESPs or baghouses by a wide margin.

Big Bend Power Station Neural Network-Sootblower Optimization

Participant

Tampa Electric Company

Additional Team Members

Pegasus Technology, Inc.—technology supplier

Location

Apollo Beach, Hillsborough County, FL (Tampa Electric's Big Bend Power Station)

Technology

Neural-network sootblowing system in conjunction with advanced controls and instruments

Plant Capacity/Production

445 MW

Coal

Unknown

Project Funding

Total	\$2,381,614	100%
DOE	905,013	38
Participant	1,476,601	62

Project Objective

To control boiler fouling on a 445-MWe unit by using a neural-network sootblowing system in conjunction with advanced controls and instruments. Ash and slag deposition compromise plant efficiency by impeding the transfer of heat to the working fluid. This leads to higher fuel consumption and higher air emissions, especially NO_x. This project is expected to reduce NO_x by 30%, improve heat rate by 2% and reduce particulate matter (PM) emissions by 5%.

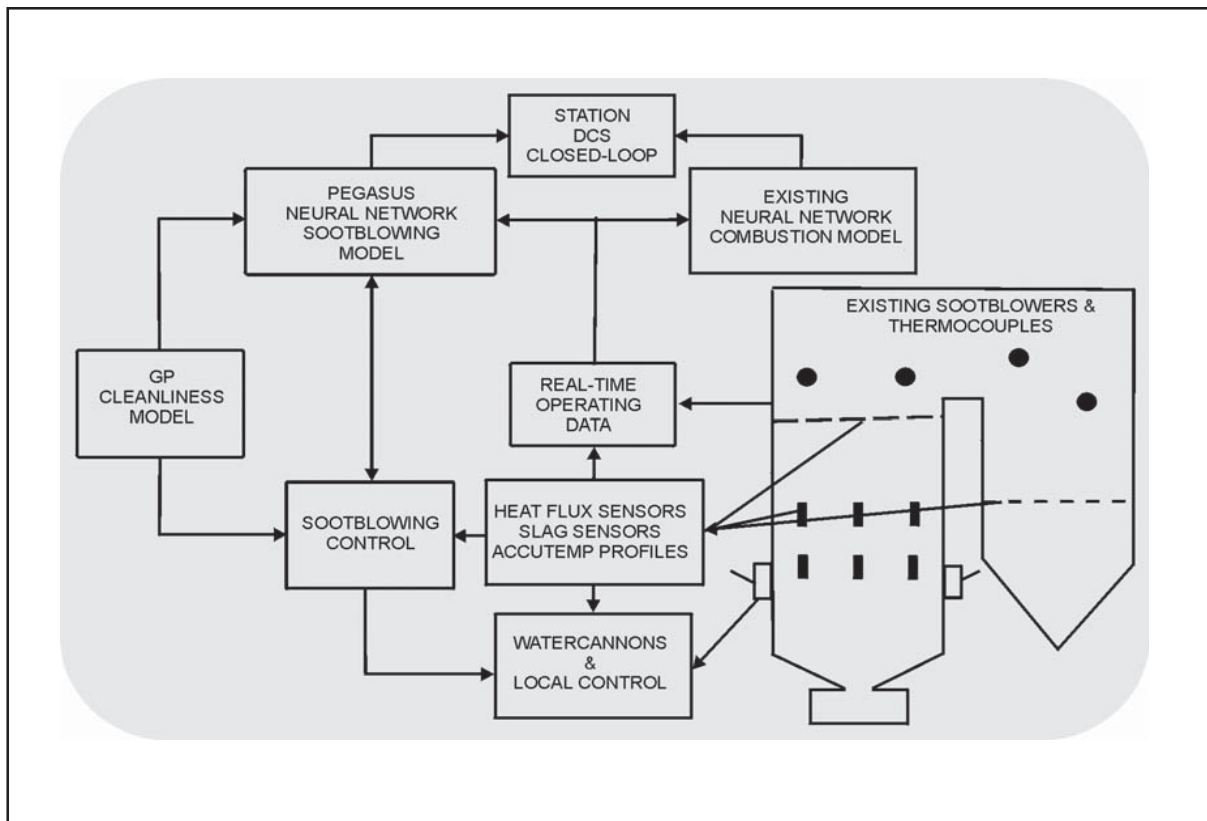

Technology/Project Description

The intent of this project is to apply a neural network intelligent sootblowing system in conjunction with state-of-the-art controls and instruments to optimize the operation of a utility boiler and systematically control boiler fouling. This optimization process is targeted to reduce total NO_x generation by up to 30%, improve heat rate by up to 2%, and reduce PM emissions by up to 5%. As compared to competing technologies, this could be an extremely cost-effective technology, which has the ability to be readily and easily adapted to virtually any pulverized coal boiler.

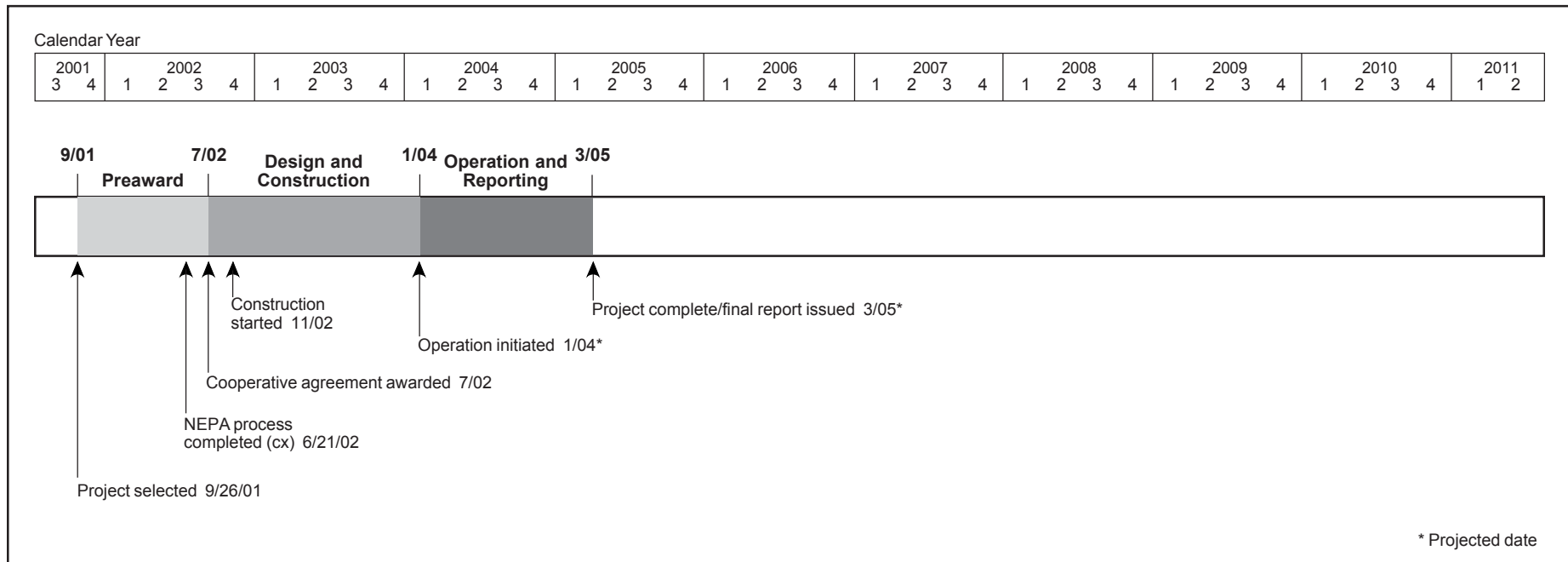

Project Status/Accomplishments

The project was selected for award on September 26, 2001. The cooperative agreement was awarded July 9, 2002 and the NEPA process was completed with a categorical exclusion issued on June 21, 2002. Construction started in November 2002 and operation is projected to start in January 2004.

Commercial Applications

One problem that exists with the combustion of coal is the formation and deposition of ash and slag within the boilers which adversely affects the rate at which heat is transferred to the working fluid, which in the case of electric generators is water/steam. The fouling of the boiler leads to poor efficiencies because heat which could normally be transferred to the working fluid remains in the flue gas stream and exits to the environment without beneficial use. This loss in efficiency translates to higher consumption of fuel for equivalent levels of electric generation, hence more gaseous emissions are also produced. Another less obvious problem exists with fouling of various sections of the boiler relating to the intensity of peak temperatures within and around the combustion zone.

Total NO_x generation is primarily a function of both fuel- and thermal-NO_x production. Fuel-NO_x, which generally comprises 20–40% of the total NO_x generated, is predominantly influenced by the levels of oxygen present, while thermal-NO_x, which comprises the balance, is a function of temperature. As the fouling of the boiler increases and the rate of heat transfer decreases, peak temperatures increase as does thermal NO_x production.

Due to the composition of coal, particulate matter is also a by-product of coal combustion. Modern day utility boilers are usually fitted with electrostatic precipitators to aid in the collection of PM. Although extremely efficient, these devices are sensitive to rapid changes in inlet mass concentration as well as total mass loading. Traditionally, utility boilers are equipped with devices known as soot-blowers, that use steam, water, or air to dislodge particulates and clean the surfaces within the boiler and are operated based upon established rules or the operator's judgment. Without extreme care and due diligence, excessive soot can overload an ESP resulting in high levels of PM being released. This technology has potential application to all of the more than 1,000 coal-fired units.

Demonstration of Integrated Optimization Software at the Baldwin Energy Complex

Participant

NeuCo, Inc.

Additional Team Members

Dynegy Midwest Generation—host

Location

Baldwin, Randolph County, Illinois (Dynegy Midwest Generation's Baldwin Energy Complex)

Technology

Advanced optimization software, building on NeuCo's ProcessLink™ technology

Project Capacity/Production

1,768 MW

Coal

Powder River Basin

Project Funding

Total	\$18,640,231	100%
DOE Share	\$ 8,388,104	45
Participant	\$10,252,127	55

Project Objective

To design, develop, and demonstrate integrated on-line optimization systems that will address combustion, soot-blowing, selective catalytic reduction (SCR) operations, overall unit thermal performance, and plant-wide profit optimization in order to reduce nitrogen oxides (NO_x) by 5%, increase efficiency by 1.5%, and improve reliability and availability to boost production by 1.5%.

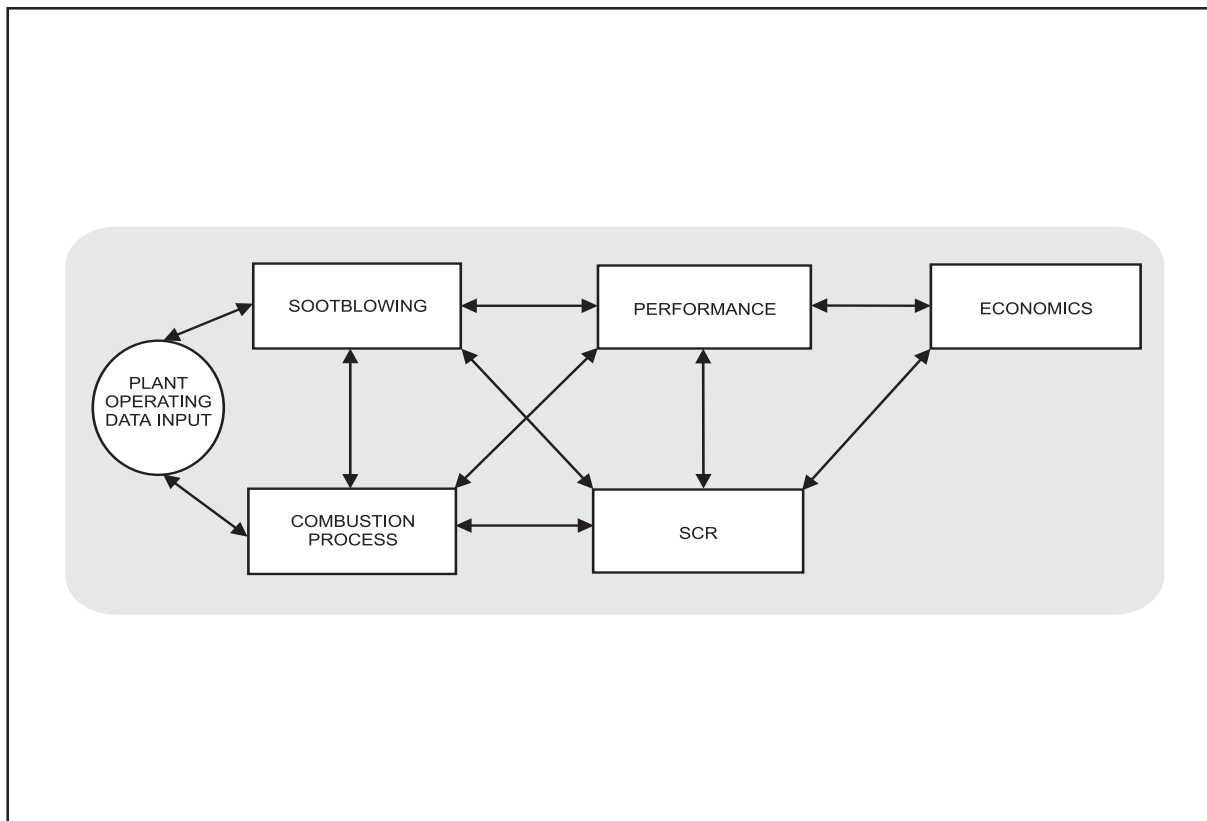

Technology/Project Description

The ProcessLink™ technology platform includes neural networks, genetic algorithms, and fuzzy logic techniques from which to comprehensively apply optimization techniques to a variety of systems within coal power plants through existing control technologies and then link these systems to each other. It also supports the development of integrative optimization solutions, which use system-specific optimization applications as data sources and actuators.

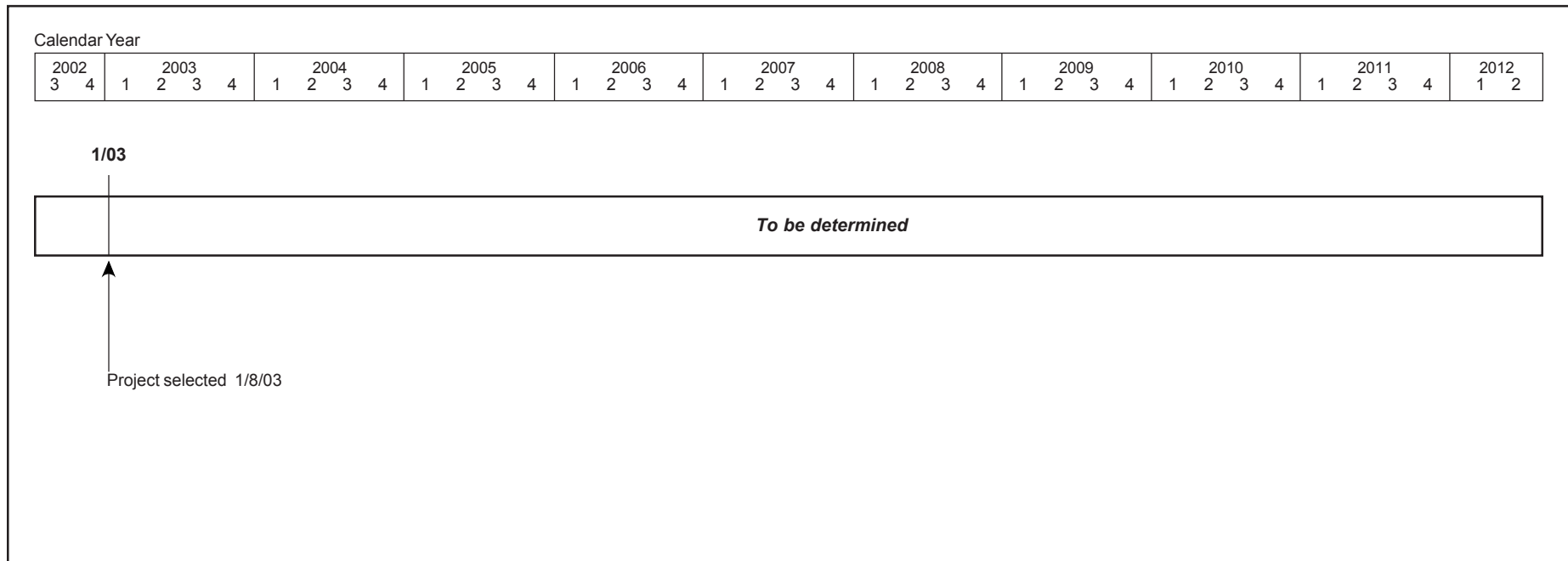

Project Status/Accomplishments

The project was selected for award on January 8, 2003. Negotiations are underway and a cooperative agreement is expected by mid- to late-2003. The project duration is expected to be four years.

The increases in fuel efficiency (heat rate reduction) will also provide commensurate reductions in greenhouse gases, mercury, and particulates. These solutions will build on NeuCo's ProcessLink™ technology platform. The proposed work will demonstrate closed-loop combustion optimization for cyclone boilers and integrate the newly developed solutions with combustion optimization at all three of the plant's nominal 600-MW coal-fired units (two cyclone-fired units with selective catalytic reduction and one tangentially fired unit with low-NO_x burners).

Commercial Applications

When completed, this project will demonstrate the applicability of integrating an on-line optimization system with power plant operations to increase the thermal efficiency of the plant, hence reducing emissions of CO₂, increasing fuel efficiency, and increasing overall reliability while achieving a corresponding reduction of airborne emissions. The increases in fuel efficiency will also provide commensurate reductions in mercury and particulates. As plant complexity increases through retrofit and repowering applications, the introduction of new technologies, and plant modifications, this integrated process optimization approach can be an important tool that supports a plant operator's control objectives and links them to corporate objectives of increased efficiency and lower emissions.

TOXECON Retrofit for Mercury and Multi-Pollutant Control on Three 90 MW Coal-Fired Boilers

Participant

Wisconsin Electric Power Company

Additional Team Members

ADA-ES—collaborator

Cummins & Barnard—collaborator

Electric Power Research Institute (EPRI)—technology supplier

Environmental Elements Corp.—collaborator

Location

Marquette, Marquette County, Michigan (Wisconsin Electric's Presque Isle Power Plant Unit Nos. 7, 8, and 9)

Technology

EPRI's patented TOXECON sorbent injection process

Project Capacity/Production

3 x 90 MW

Coal

Powder River Basin

Project Funding

Total	\$49,536,624	100%
DOE Share	\$24,768,312	50
Participant	\$24,768,312	50

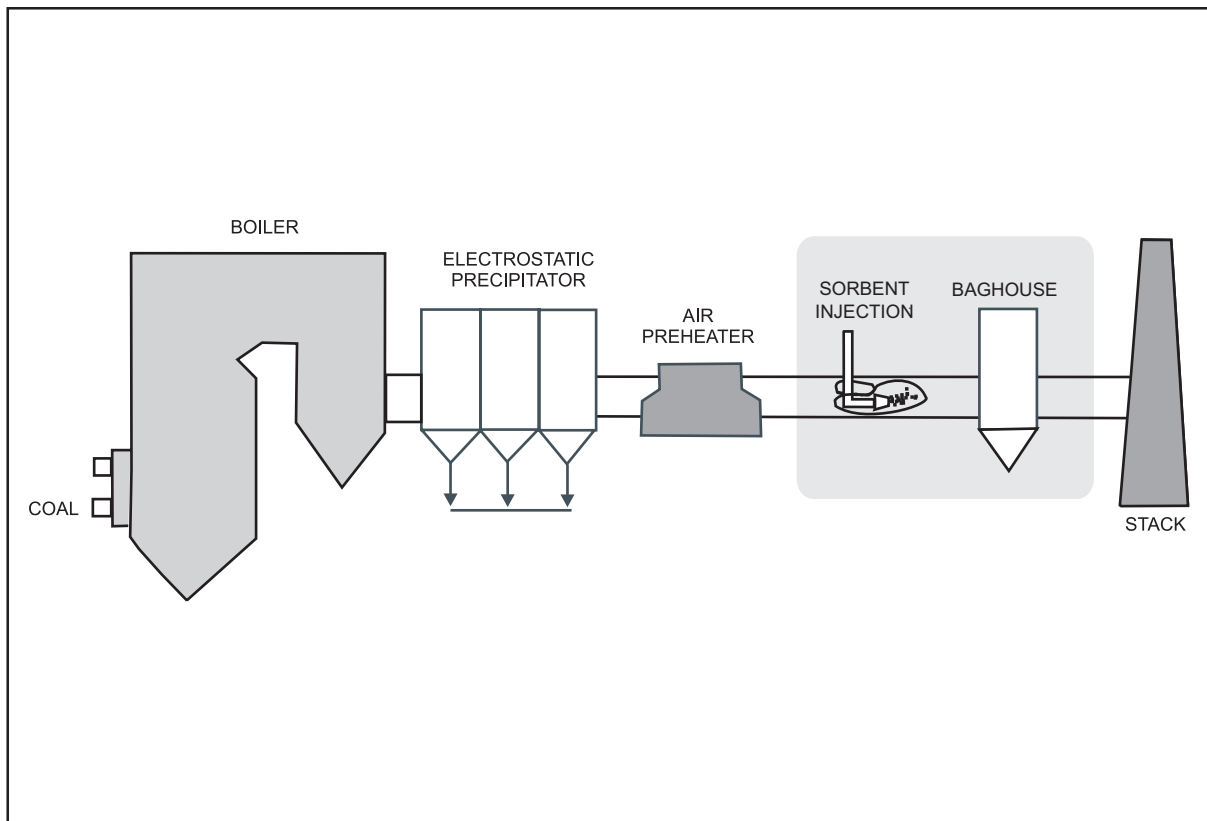

Project Objective

To demonstrate EPRI's patented TOXECON process, which injects sorbents into a pulse-jet baghouse installed downstream of the existing particulate matter (PM) control device for mercury (Hg), other air toxics, sulfur dioxide (SO₂), and nitrogen oxides (NO_x) control. Specific objectives are to achieve 90% Hg removal through injection of activated carbon into the flue gas stream, increase PM collection efficiency, determine the viability of sorbent injection for up to 70% SO₂ control and trim control of NO_x, recover 90% of Hg captured in the sorbent, achieve 100% fly ash utilization, advance reliability of Hg continuous emission monitors, and successfully integrate the entire system.

Technology / Project Description

The activated carbon and other sorbents will be delivered into the flue gases between the primary PM control device and the new baghouse. Injection of activated carbon in this manner has distinct advantages over direct injection of activated carbon into an electrostatic precipitator (ESP), which depends on in-flight adsorption of mercury by sorbent particles, whereas in a baghouse both in-flight and fixed-bed capture occur as the flue gas passes through the filter cake on the fabric filter. TOXECON generally has lower carbon injection rates, and has higher capture efficiencies in some cases than direct injection into an ESP. In addition, injection downstream of the primary PM control device does not contaminate fly ash with carbon, allowing for sale and use of the fly ash by-product.

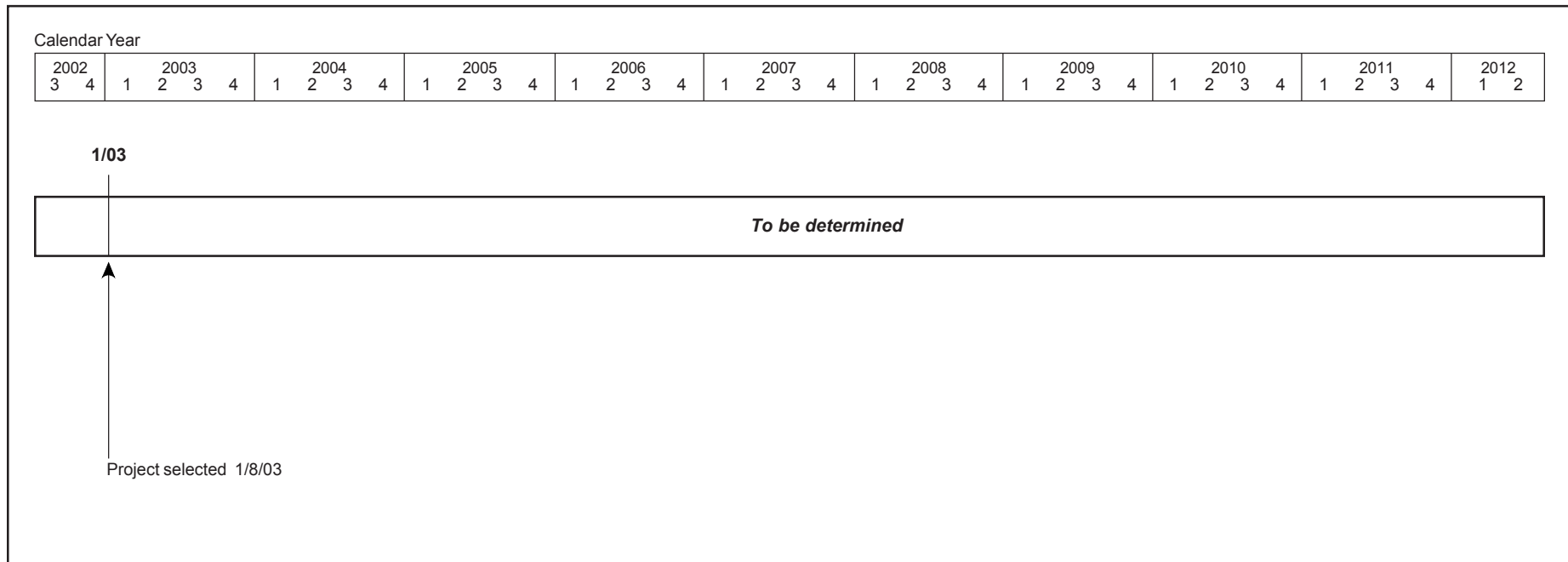

Project Status/Accomplishments

This project was selected for award on January 8, 2003. Negotiations are underway, and a cooperative agreement is expected in mid- to late-2003.

The TOXECON configuration allows for separate treatment, disposal, or sale of ash collected in the primary PM control device. It is expected that when completed in 2008, this technology demonstration project will reduce Hg emissions by 90% and result in capture of about 97 pounds of mercury per year that would otherwise have been emitted to the environment from the three units combined. The multi-pollutant control strategy could be expected to reduce the already low SO₂ and NO_x emissions at the plant by an additional 70% and 30%, respectively, resulting in capture of 4,020 tons per year of SO₂ and 1,470 tons per year of NO_x. In addition, emission of PM would be reduced by 32 tons per year.

Short-term, large-scale testing of activated carbon injection in flue gases has shown that Hg capture results averaged from 87–90% with a carbon injection rate of 1.5 pounds per million cubic feet of flue gas. Additional testing over longer periods is needed to determine the

impact of carbon injection on fabric filter bag life, cleaning frequency, and particulate collection efficiency. Powder River Basin (PRB) coal, like that fired at the Presque Isle plant, has a high percentage of elemental, as opposed to oxidized, mercury. Activated carbon is known to capture elemental mercury, the most challenging species of mercury to capture. Other test results have shown that sodium-based products can achieve 30% to 70% reduction in SO₂ emissions, but at normal flue gas temperatures calcium-based products are not effective. Sodium based sorbents have also reduced NO_x by 10% to 20%. A HCl removal efficiency of 50% has been documented with injection of sodium-based sorbents.

Commercial Applications

The technology can be incorporated into systems that currently employ cold-side ESPs, as well as hot-side ESPs as primary PM control devices. Injection of sorbents will take place downstream of the air heater in systems employing hot-side ESPs, such as the Presque Isle Plant, where relatively cool temperatures below 350 °F allow absorption of Hg by activated carbon. TOXECON is one of the few mercury control technologies that can be ap-

plied to systems employing a hot-side ESP because temperatures are generally too high in the ESP to allow for absorption upstream or in the ESP.

A primary benefit of this project is its potential as a low-cost option for dramatic, deep cleaning of plant air emissions, especially those of mercury. The project's successful implementation will help provide an approach for segments of the power-generating industry to achieve timely compliance with future mercury regulations.

This technology may prove to be the primary Hg control choice for western coals and the only choice for units burning any coal type with a hot-side ESP. Thus, the TOXECON process has application at unscrubbed power plants burning coals with hot-side ESPs (18 GW), plants burning western, sub-bituminous coals with cold-side ESPs (68 GW), and plants burning bituminous coals with cold-side ESPs (81 GW). Using TOXECON to control SO₂ and NO_x further enhances its attractiveness for improved environmental control.

Advanced Electric Power Generation

JEA Large-Scale CFB Combustion Demonstration Project

Participant

JEA (formerly Jacksonville Electric Authority)

Additional Team Members

Foster Wheeler Energy Corporation—technology supplier

Location

Jacksonville, Duval County, FL (JEA's Northside Station, Unit No. 2)

Technology

Foster Wheeler's atmospheric circulating fluidized-bed (ACFB) combustor

Plant Capacity/Production

297.5 MWe (gross), 265 MWe (net)

Coal

Eastern bituminous, 3.39% sulfur (design)

Project Funding

Total	\$309,096,512	100%
DOE	74,733,633	24
Participant	234,362,679	76

Project Objective

To demonstrate ACFB at 297.5 MWe gross (265 MWe net) representing a scale-up from previously constructed facilities; to verify expectations of the technology's economic, environmental, and technical performance; to provide potential users with the data necessary for evaluating a large-scale ACFB as a commercial alternative; to accomplish greater than 90% SO₂ removal; and to reduce NO_x emissions by 60% when compared with conventional technology.

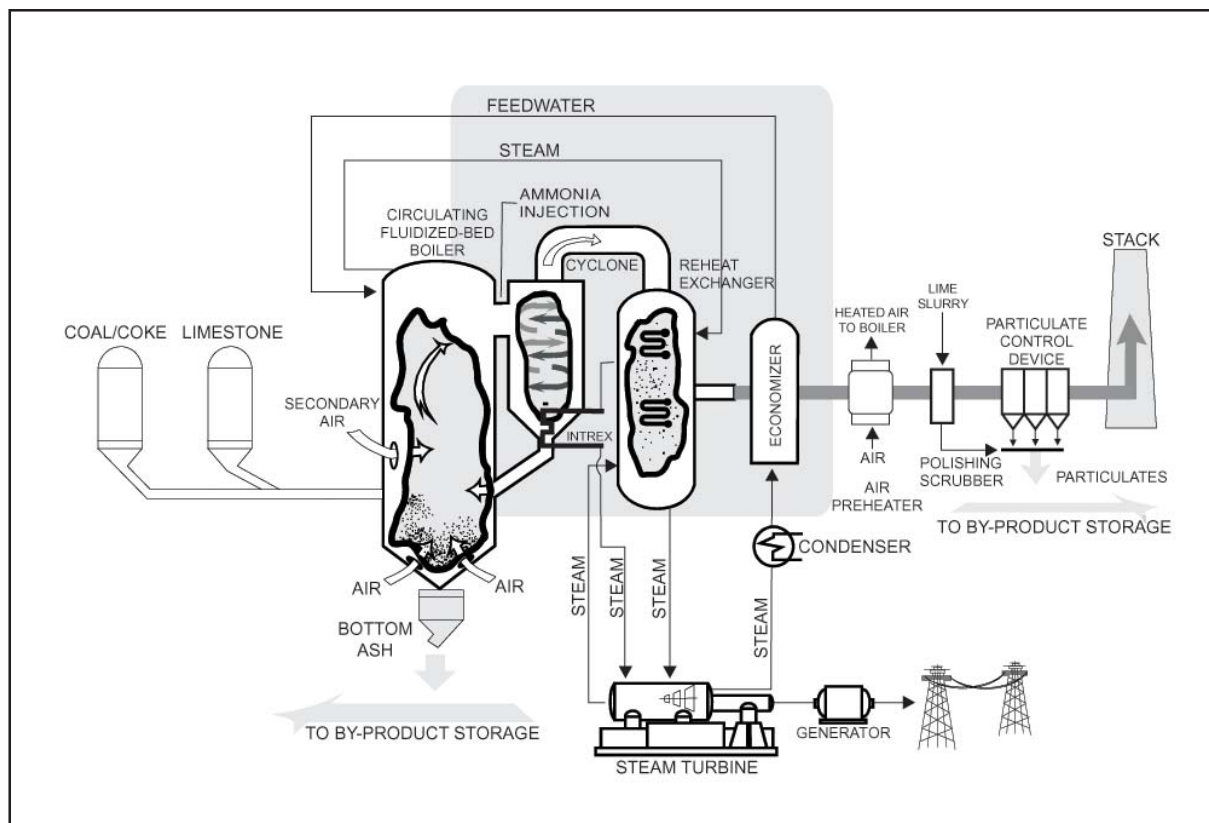

Technology/Project Description

A circulating fluidized-bed combustor, operating at atmospheric pressure, will be retrofitted into Unit No. 2 of the Northside Station. In this process coal or the secondary fuel (petroleum coke), primary air, and a solid sorbent (such as limestone), are introduced into the lower part of the combustor where initial combustion occurs. As the coal particles decrease in size due to combustion, they are carried higher in the combustor when secondary air is introduced. As the coal particles continue to be reduced in size, the coal, along with some of the sorbent, is carried out of the combustor, collected in a cyclone separator, and recycled to the lower portion of the combustor. Primary sulfur capture is achieved by the sorbent in the bed. However, additional SO₂ capture is achieved through the use of a polishing scrubber to be installed ahead of the particulate control equipment.

Steam is generated in tubes placed along the combustor's walls and superheated in tube bundles placed downstream of the particulate separator to protect against erosion. The system will produce approximately 2×10^6 lb/hr of main steam at about 2,500 psig and 1,005 °F, and 1.73×10^6 lb/hr of reheat steam at 600 psig and 1,005 °F. The steam will be used in an existing 297.5-MWe (nameplate) steam turbine.

The heat rate for the retrofit plant is expected to be approximately 9,950 Btu/kWh (34% efficiency; HHV). Expected environmental performance is 0.15 lb/10⁶ Btu for SO₂ (98% reduction), 0.09 lb/10⁶ Btu for NO_x, and 0.011 lb/10⁶ Btu for total particulates (0.011 lb/10⁶ Btu for PM₁₀).

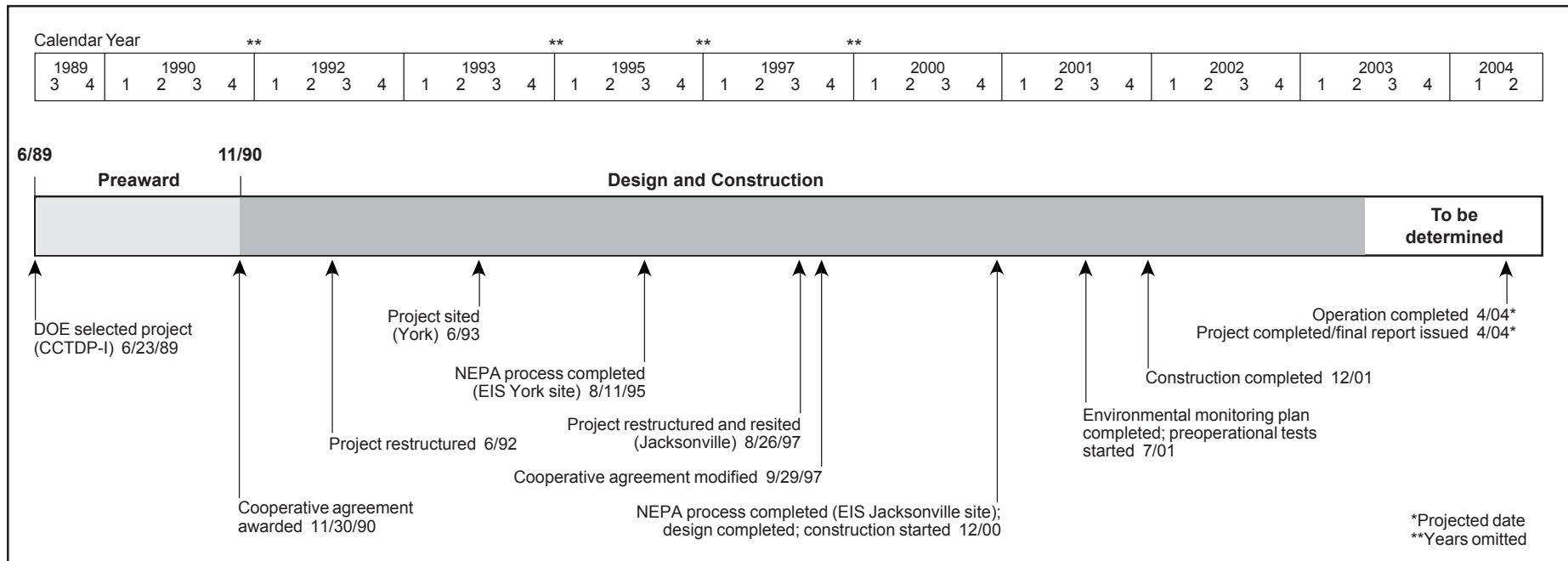

Project Status/Accomplishments

The project was successfully resited to Jacksonville, Florida after York County Energy Partners and Metropolitan Edison Company terminated activities on the ACFB project in September 1996. On August 26, 1997, DOE approved the transfer of the ACFB Clean Coal Project from York, Pennsylvania to Jacksonville, Florida. On September 29, 1997, DOE signed a modified cooperative agreement with JEA to cost-share refurbishment of the first (Unit No. 2) of two units at Northside Generating Station.

The National Environmental Policy Act process was completed when the Record of Decision was issued on December 7, 2000. The facility was dedicated on October 14, 2002. The operation and reporting period has been delayed and a new scheduled has not been set.

Following a two-week unscheduled outage, Unit No. 2 was returned to service on January 8, 2003. The unit was taken offline on January 28, 2003, to repair external tube leaks on one of the cyclones. On February 11, 2003, the fuel was switched to an 80/20 blend of petcoke/coal. The unit operated on the 80/20 blend for six weeks without experiencing an unscheduled outage. A planned 22-day

outage started on April 1, 2003, to incorporate modifications and upgrades necessary to prepare the unit for the summer peak period. The work items included the repair of the INTREX™ inlet expansion joint from the cyclone and the INTREX™ outlet refractory shielding pillows. The schedule for the demonstration operations is yet to be determined.

The project moves atmospheric fluidized-bed combustion technology to the larger sizes of utility boilers typically considered in capacity additions and replacements. The nominal 300-MWe demonstration unit in the JEA project will be more than double the size of the Nucla unit (110-MWe). Features include an INTREX™ integrated recycle heat exchanger in the furnace, steam-cooled cyclones, a parallel pass reheat control, an SO₂ polishing scrubber, and a fabric filter for particulate control.

The project received *Power* magazine's 2002 Power Plant Award. The Florida Engineering Society awarded JEA's project manager the Technical Achievement Award 2002 for his work on the project.

Commercial Applications

The ACFB technology has good potential for application in both the industrial and utility sectors, whether for use in repowering existing plants or in new facilities. Also, ACFB is attractive for both baseload and load-following power applications because it can be efficiently turned down to 25% of full load. While the efficiency of ACFB is on par with conventional pulverized coal-fired plants, the advantage of ACFB is that coal of any sulfur or ash content can be used, and any type or size unit can be repowered. In repowering applications, an existing plant area is used, and coal- and waste-handling equipment, as well as steam turbine equipment, is retained, thereby extending the life of the plant.

In its commercial configuration, ACFB technology offers several potential benefits when compared with conventional pulverized coal-fired systems: lower capital costs; reduced SO₂ and NO_x emissions at lower costs; higher combustion efficiency; a high degree of fuel flexibility (including use of renewable fuels); and dry, granular solid by-product material that is easily disposed of or potentially salable.

Next Generation CFB Coal Generating Unit

Participant

Colorado Springs Utilities, an enterprise of the City of Colorado Springs

Additional Team Members

Foster Wheeler Power Group, Inc.—technology supplier

Location

Fountain, El Paso County, Colorado (Colorado Springs Utilities' Ray D. Nixon Power Plant)

Technology

Foster Wheeler circulating fluidized-bed (CFB) combustion system and advanced selective non-catalytic reduction (SNCR)

Plant Capacity/Production

150 MW

Coal

Sub-Bituminous Powder River Basin (PRB)

PRB blended with coal waste, biomass, petroleum coke

Project Funding

Total	\$301,504,011	100%
DOE Share	\$ 30,000,000	10
Participant	\$271,504,011	90

Project Objective

To demonstrate an advanced low-emission CFB combustion system that is expected to achieve 96–98% sulfur removal, while reducing limestone consumption to less than half of conventional CFB systems. The system also features an integrated trace metal control system that can remove up to 90% of mercury, lead, and other metals, as well as virtually all acid gases in the flue gas.

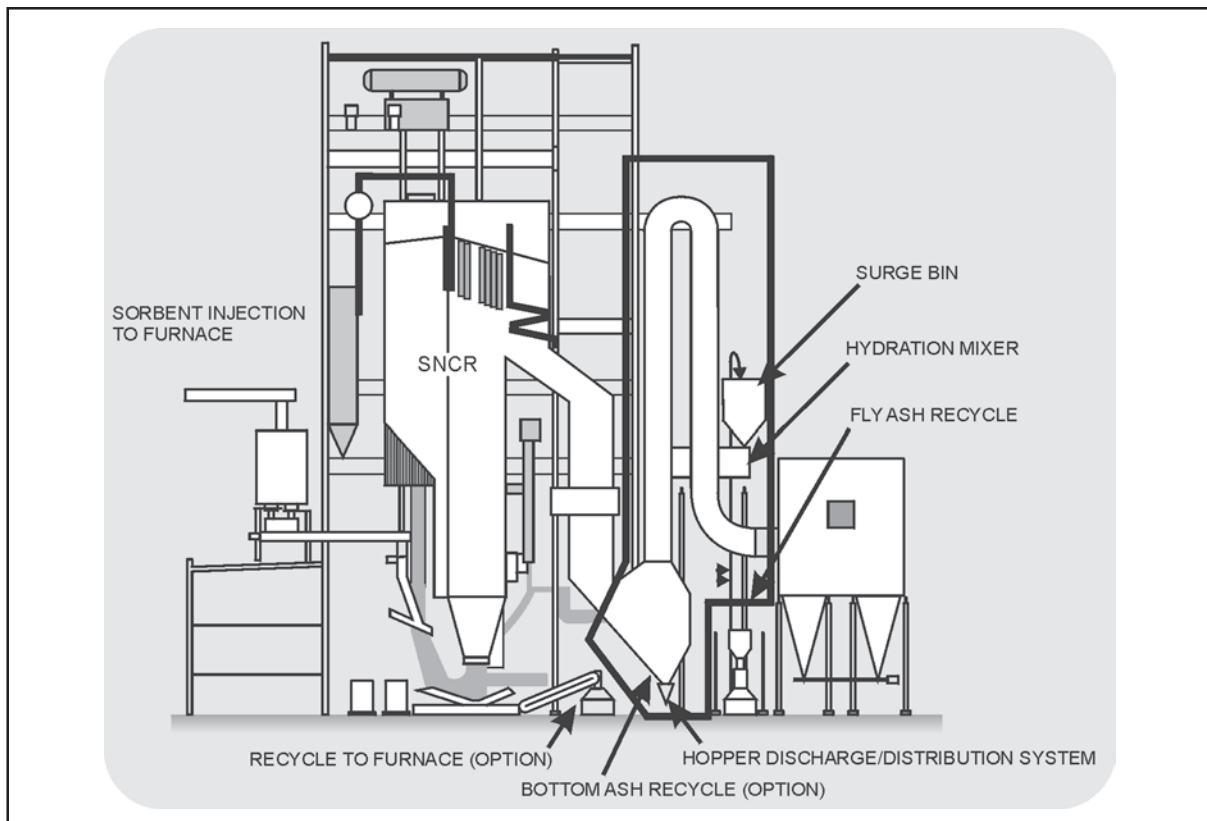

Technology/Project Description

For nitrogen oxides (NO_x), the system features an advanced staged-combustion process coupled with an advanced SNCR system that can reduce stack NO_x levels to those achievable only with higher cost selective catalytic reduction (SCR) technology. For sulfur oxides (SO_x), the design features a three-stage approach to achieve the highest sulfur capture with the lowest limestone consumption. Unlike other processes, the limestone fed to the furnace is the only source of reagent added for sulfur removal. To improve reliability and lower cost, the design features an advanced integrated solids separator system integrated into the traditional furnace structure instead of traditional cyclones.

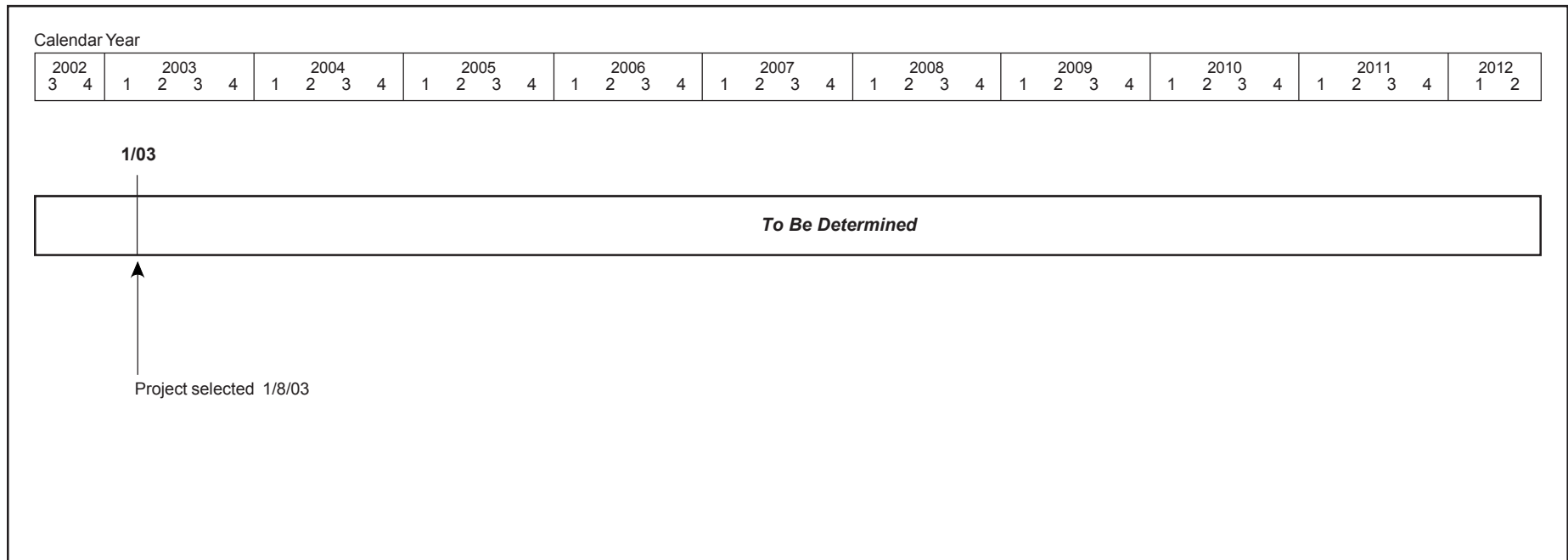

Project Status/Accomplishments

The project was selected for award on January 8, 2003. Negotiations are underway and the cooperative agreement is expected to be awarded mid- to late-2003. The project is expected to last about six years.

Commercial Applications

This demonstration project offers the opportunity for a low-cost advanced emissions control system applicable to a variety of coals and other fuels for CFBs. The system is predicted to achieve low levels of NO_x (0.04 lb/10⁶ Btu with Powder River Basin coal) using an advanced selective non-catalytic reduction system, very-high sulfur control at 96–98 percent reductions using a three-stage collection system to substantially reduce limestone as compared to more conventional CFBs, and a trace metal emissions control system with potential to remove up to 90 percent of mercury contained in the fuel feed. This demonstration project will also use a suite of fuels including Powder River Basin subbituminous, Illinois and Pittsburgh eastern bituminous, waste coal and biomass/ woodwaste while achieving high levels of emissions control. If successful, this unit would become the cleanest

coal-fired electric power plant in the country and could eliminate hazardous forest deadwood biomass (important to local efforts in wildfire management). The plant includes a dry cooling tower to minimize water use (an increasingly important consideration in power plant design). Colorado Springs is one of the fastest growing cities in the region and will benefit by lower power costs from using clean coal technology. The project incorporates an advanced control system (including mercury control) that will be applicable to new and some existing CFB units and will demonstrate fuel flexibility for western and eastern coals as well as waste coals. Co-firing with biomass supports effective carbon management objectives as well.

Kentucky Pioneer Energy IGCC Demonstration Project

Participant

Kentucky Pioneer Energy, LLC

Additional Team Members

Fuel Cell Energy, Inc. (formerly Energy Research Corporation)—molten carbonate fuel cell designer and supplier, and cofunder

Location

Trapp, Clark County, KY (East Kentucky Power Cooperative's Smith site)

Technology

Integrated gasification combined-cycle (IGCC) using a BG/L (formerly British Gas/Lurgi) slagging fixed-bed gasification system coupled with Fuel Cell Energy's molten carbonate fuel cell (MCFC)

Plant Capacity/Production

580 MWe (gross); 540 MWe (net) IGCC; 2.0 MWe MCFC

Coal

High-sulfur Kentucky bituminous coal and pelletized refuse-derived fuel (RDF)

Project Funding

Total	\$431,932,714	100%
DOE	78,086,357	18
Participant	353,846,225	82

Project Objective

To demonstrate and assess the reliability, availability, and maintainability of a utility-scale IGCC system using a high-sulfur bituminous coal and refuse-derived fuel (RDF) blend in an oxygen-blown, fixed-bed, slagging gasifier and the operability of a molten carbonate fuel cell fueled by coal gas.

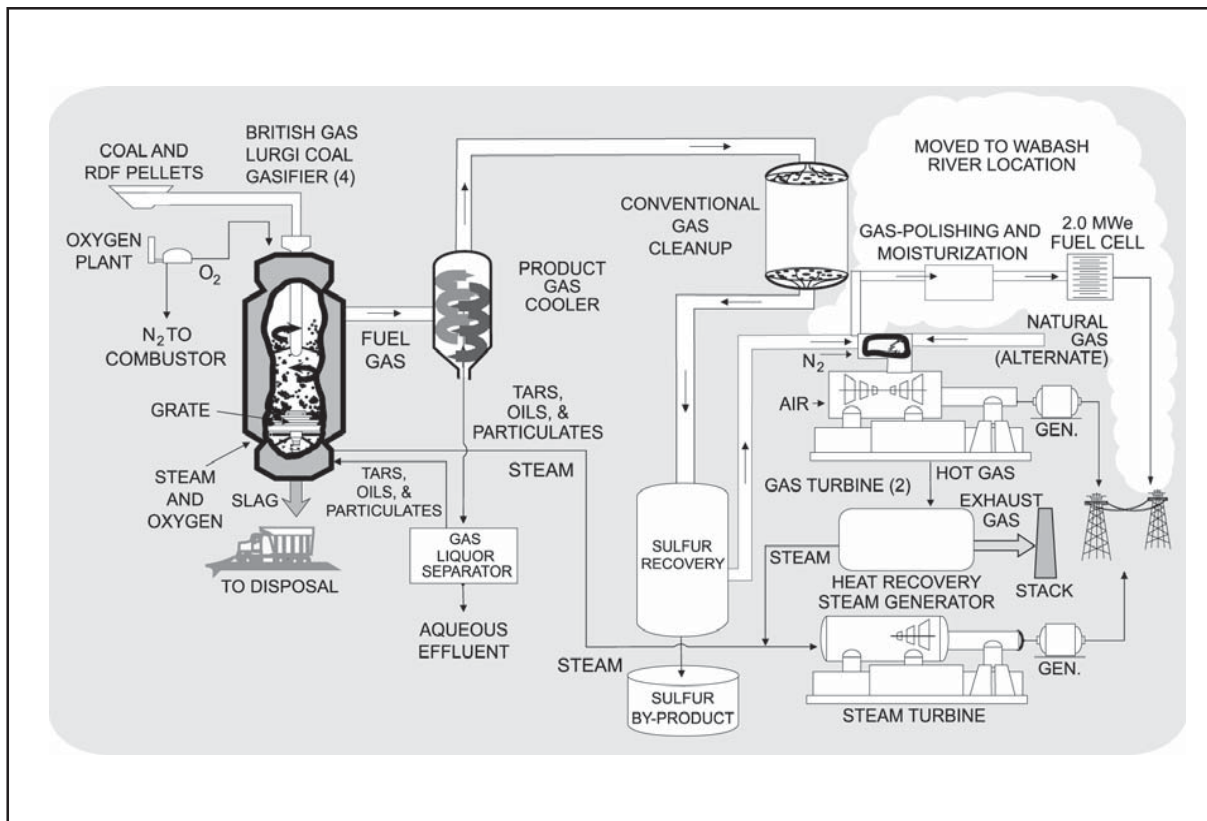

Technology/Project Description

The four BG/L gasifiers are supplied with steam, oxygen, limestone flux, and a coal and pelletized RDF. During gasification, the oxygen and steam react with the coal and limestone flux to produce a coal-derived fuel gas rich in hydrogen and carbon monoxide. Raw fuel gas exiting the gasifier is washed and cooled. Hydrogen sulfide and other sulfur compounds are removed. Elemental sulfur is reclaimed and sold as a by-product. Tars, oils, and dust are recycled to the gasifier. Instead of ash, the inorganic components in the feedstock are reduced to a non-leaching silica matrix that will be used as a synthetic aggregate. The resulting clean, medium-Btu fuel gas fires two gas turbines. Operation will commence on 100% coal with slowly increasing levels of RDF throughout the demonstration. This method will allow the development of a database of plant performance at various levels of RDF feed.

The MCFC, which has been relocated to another site, is composed of a molten carbonate electrolyte sandwiched between porous anode and cathode plates. Fuel (desulfurized, heated medium-Btu fuel gas) and steam are fed continuously into the anode; CO₂-enriched air is fed into the cathode. Chemical reactions produce direct electric current, which is converted to alternating current with an inverter.

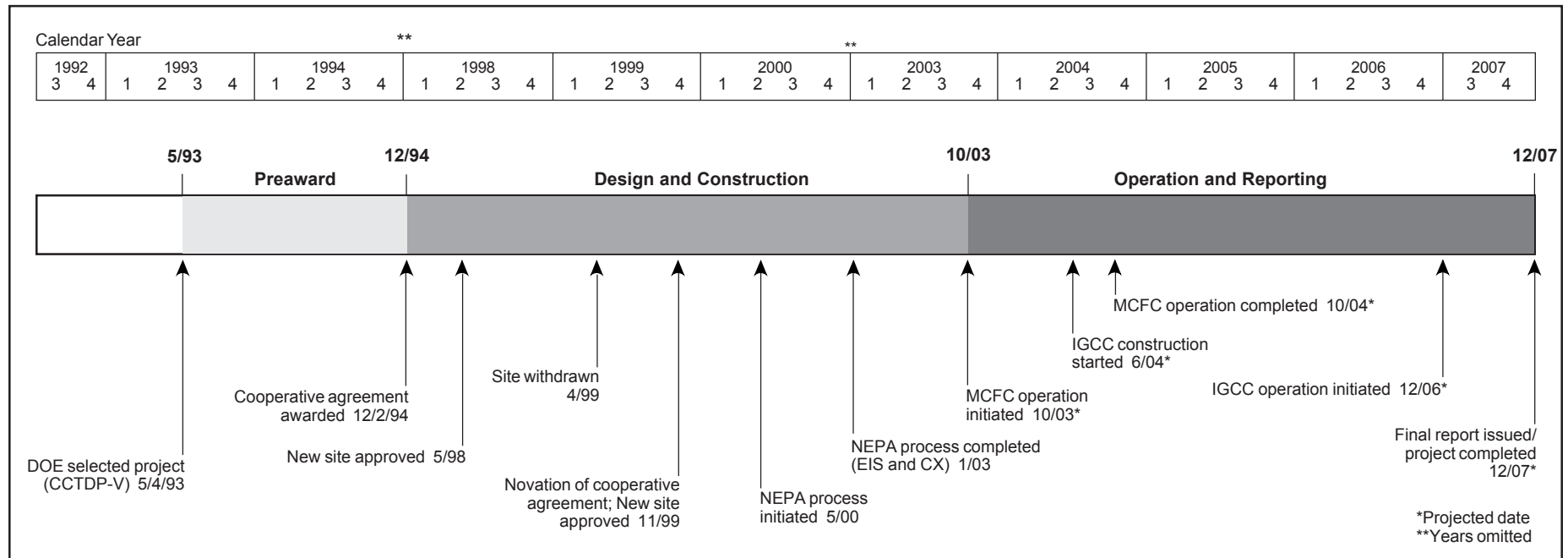

Project Status/Accomplishments

On May 8, 1998, DOE conditionally approved Ameren Services Company (merger of Union Electric Co. and Central Illinois Public Service Co.) as an equity partner and host site provider subject to completing specific business and teaming milestones. The new project site to be provided by Ameren was at its Venice Station Plant in Venice, Illinois. On April 30, 1999, Ameren Services Company withdrew from the project for economic and business reasons.

In May 1999, Global Energy USA Limited (Global), sole owner of Kentucky Pioneer Energy, LLC (KPE), expressed interest in acquiring the project and providing a host site at East Kentucky Power Cooperative's Smith Site in Clark County, Kentucky. Subsequently, Global negotiated all the necessary documents with DOE and Clean Energy Partners, L.P. (CEP) to acquire the project. In November 1999, the cooperative agreement was novated and the new site was approved.

The NEPA process for the IGCC plant was completed with the Record of Decision being issued on January 29, 2003. The NEPA process for the fuel cell was completed with the issue of a categorical exclusion on September 30, 2002.

The heat rate of the IGCC demonstration facility is projected to be 8,560 Btu/kWh (40% efficiency) and the commercial embodiment of the system has a projected heat rate of 8,035 Btu/kWh (42.5% efficiency). These efficiencies represent a greater than 20% reduction in emissions of CO₂ when compared with a conventional pulverized coal plant equipped with a scrubber. The SO₂ emissions from the IGCC system are expected to be less than 0.1 lb/10⁶ Btu (99% reduction); and NO_x emissions less than 0.15 lb/10⁶ Btu (90% reduction).

The fuel cell portion of the project has been relocated to Global Energy's Wabash site and was dedicated in August 2003. The fuel cell will be operated on coal-derived syngas. The move will advance the MCFC demonstration by two years.

Commercial Applications

The IGCC system being demonstrated in this project is suitable for both repowering applications and new power plants. The technology is expected to be adaptable to a wide variety of potential market applications because of several factors. First, the BG/L gasification technology has successfully used a wide variety of U.S. coals. Also,

the highly modular approach to system design makes the BG/L-based IGCC and MCFC competitive in a wide range of plant sizes. In addition, the high efficiency and excellent environmental performance of the system are competitive with or superior to other fossil-fuel-fired power generation technologies.

Clean Coal Diesel Demonstration Project

Participant

TIAX, LLC (acquired the research contracts of Arthur D. Little, Inc.)

Additional Team Members

University of Alaska at Fairbanks (UAF)—host and cofunder

Fairbanks Morse Engine—diesel engine technology vendor

Gatliff Coal Company—coal supplier

Usibelli Coal Mine, Inc.—coal supplier

Location

Fairbanks, AK (University of Alaska facility)

Technology

Fairbanks Morse coal-fueled diesel engine

Plant Capacity/Production

6.4 MWe (net)

Coal

Kentucky bituminous and Alaskan subbituminous

Project Funding

Total	\$47,636,000	100%
DOE	23,818,000	50
Participant	23,818,000	50

Project Objective

To prove the design, operability, durability of a coal diesel engine during 1,000 hours of operation on coal water fuel.

Technology/Project Description

The Clean Coal Diesel Demonstration Project, as originally conceived, was to use a coal-water-fuel (CWF) slurry to operate an 18-cylinder diesel engine at the University of Alaska Fairbanks (UAF). Primarily because no coal slurry processor could be identified in Alaska to

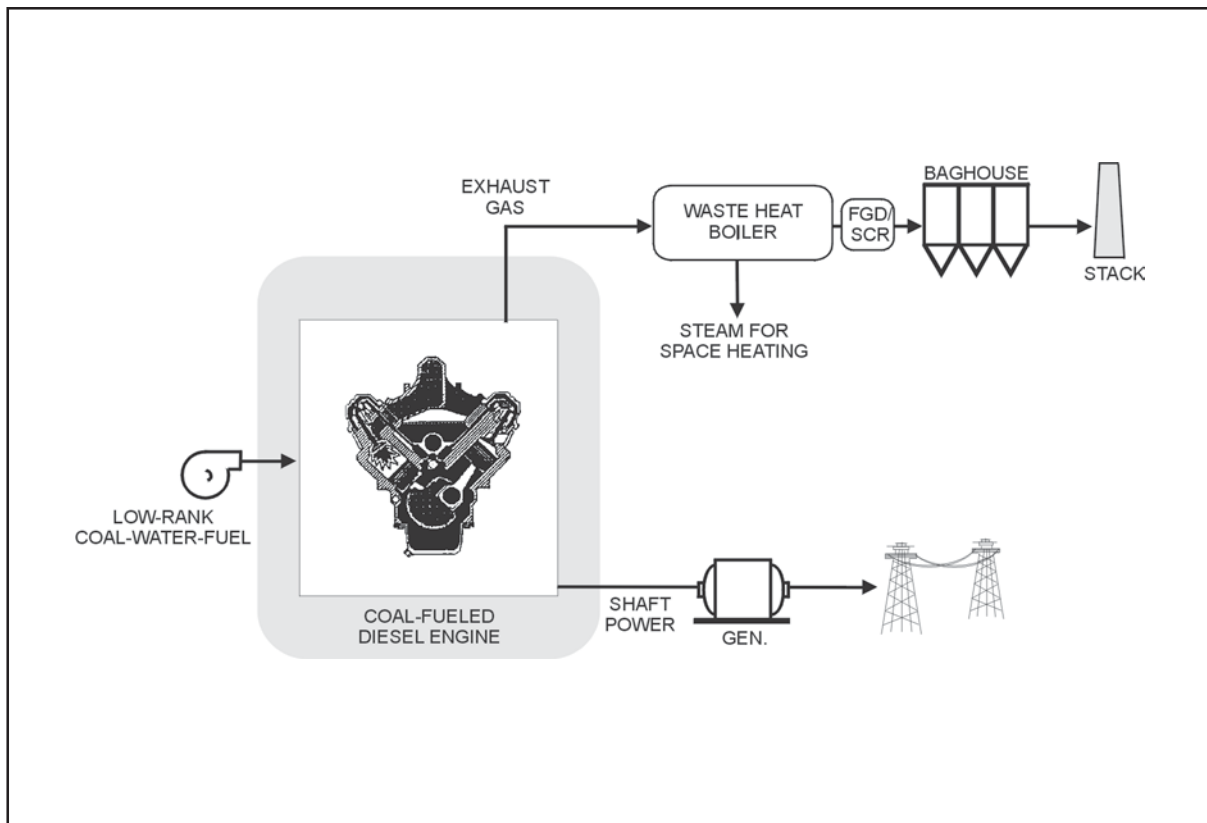

provide the necessary fuel to operate the UAF 18-cylinder engine, the scope of the project was modified. The new project scope includes 1,000 hours of testing on a two-cylinder engine in Wisconsin using a Kentucky coal source for slurry fuel. The two-cylinder engine in Wisconsin is identical to the 18-cylinder engine in Alaska in nearly every respect except for the number of cylinders. The two engines have identical horsepower per cylinder, emissions per cylinder, fueling rate per cylinder, wear rates, exhaust flow per cylinder, *etc.*

Initial tests will be conducted primarily on Kentucky bituminous CWF from the Gatliff Coal Company and on Alaskan subbituminous CWF from Usibelli Coal Mine, Inc. The clean coal diesel technology is expected to have very low NO_x and SO₂ emission levels. The 2-cylinder engine will first operate without hardened parts as an acceptance test for the CWF formulation and special fuel

injectors. This initial operation will serve to define engine operation parameters, such as air preheat, number and size of injector tip holes, timing of start of injection, amount of diesel fuel pilot, and timing of diesel fuel pilot. After initial testing, the 2-cylinder engine will be modified to add hardened parts and operated on Kentucky bituminous CWF for 12 hours per day for a total of 1000 hours. The testing will be conducted in a series of four 250-hour tests, between which Fairbanks Morse Engine will inspect engine parts. Simultaneously, UAF will prepare the 18-cylinder diesel engine for future CWF operation by modifying the cooling system, modifying the injectors, adding selective catalytic reduction (SCR), and installing hardened parts. The 18-cylinder diesel engine testing will establish a baseline for NO_x and particulate emissions on diesel fuel and provide additional data for operation with hardened parts.

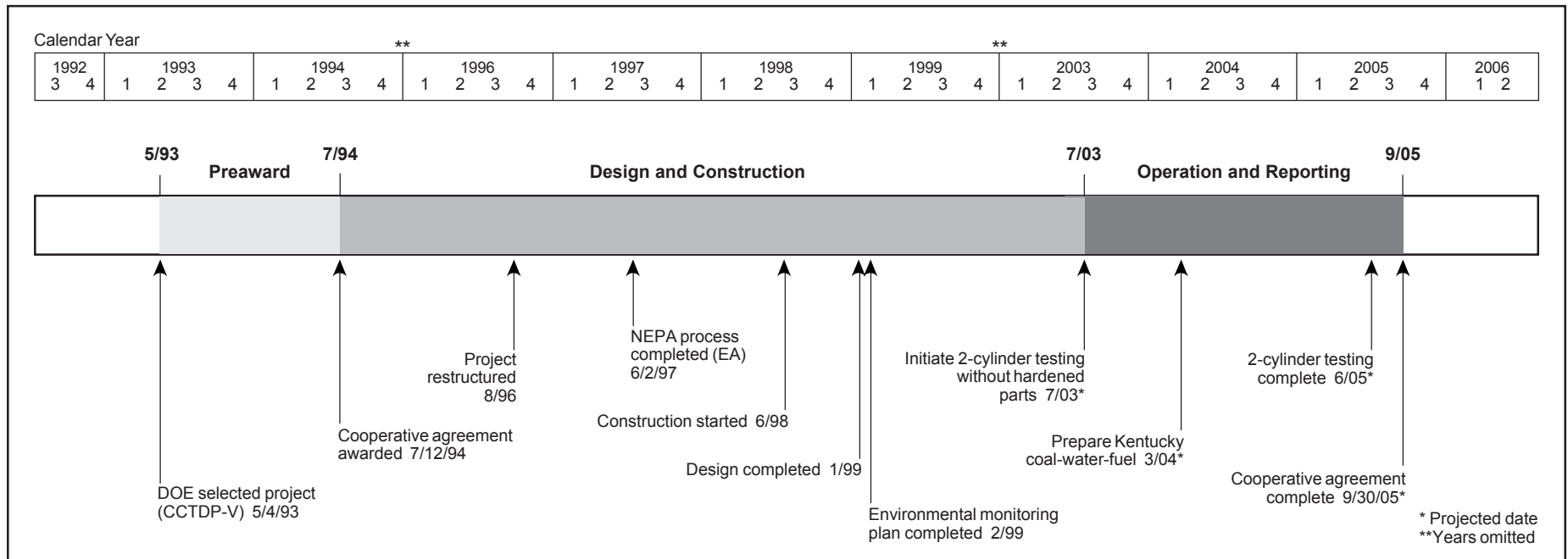

Project Status/Accomplishments

Overall project system design was completed in early 1999. The 18-cylinder diesel engine arrived on site at UAF in January 1999 and was mounted in the engine house in late February. In October 1999, the engine, after being connected to the generator, was operated on diesel fuel to ensure it would function coupled with the generator. In May 2000, total system startup was attempted on diesel fuel. The SCR system for the diesel was tested in August 2000 and achieved 90% reduction in NO_x emissions, which was within contract specifications. Since August 15, 2000, the diesel has been supplying all of the university's power requirements on fuel oil.

Testing was temporarily halted because the Goodrich Corp. division that operates the test facility, Engineered Industrial Products (which included Fairbanks Morse Engine), was spun off as a separate business now owned by EnPro Industries. As a result, the scope of the project was revised and the focus shifted to the 2-cylinder diesel engine as the optimal way to meet the demonstration project's objectives.

Commercial Applications

The U.S. diesel market is projected to exceed 60,000 MWe (over 7,000 engines) through 2020. The worldwide market is 70 times the U.S. market. The technology is particularly applicable to distributed power generation in the 5- to 20-MWe range, using indigenous coal in developing countries.

The net effective heat rate for the mature diesel system is expected to be 6,830 Btu/kWh (48% efficiency), which makes it very competitive with similarly sized coal- and fuel oil-fired installations. Environmental emissions from commercial diesel systems should be reduced to levels between 50% and 70% below NSPS. The estimated installation cost of a mature commercial unit is approximately \$1,300/kW.

Coal Processing for Clean Fuels

Lignite Fuel Enhancement

Participant

Great River Energy (GRE)

Additional Team Members

Electric Power Research Institute—collaborator

Lehigh University—collaborator

Barr Engineering—collaborator

Falkirk Mining and Couteau Properties—collaborator

Location

Underwood, McLean County, North Dakota (GRE's Coal Creek Station)

Technology

High-moisture coal enhancement by incrementally drying using waste heat

Plant Capacity/Production

546 MW

Coal

Lignite

Project Funding

Total	\$22,000,000	100%
DOE Share	\$11,000,000	50
Participant	\$11,000,000	50

Project Objective

To demonstrate a 5 to 15 percentage point reduction in lignite moisture content (about 1/4 the total moisture content) by incremental drying using waste heat from the power plant in order to significantly enhance the value of lignite as a fuel in electrical generation power plants within the next five years.

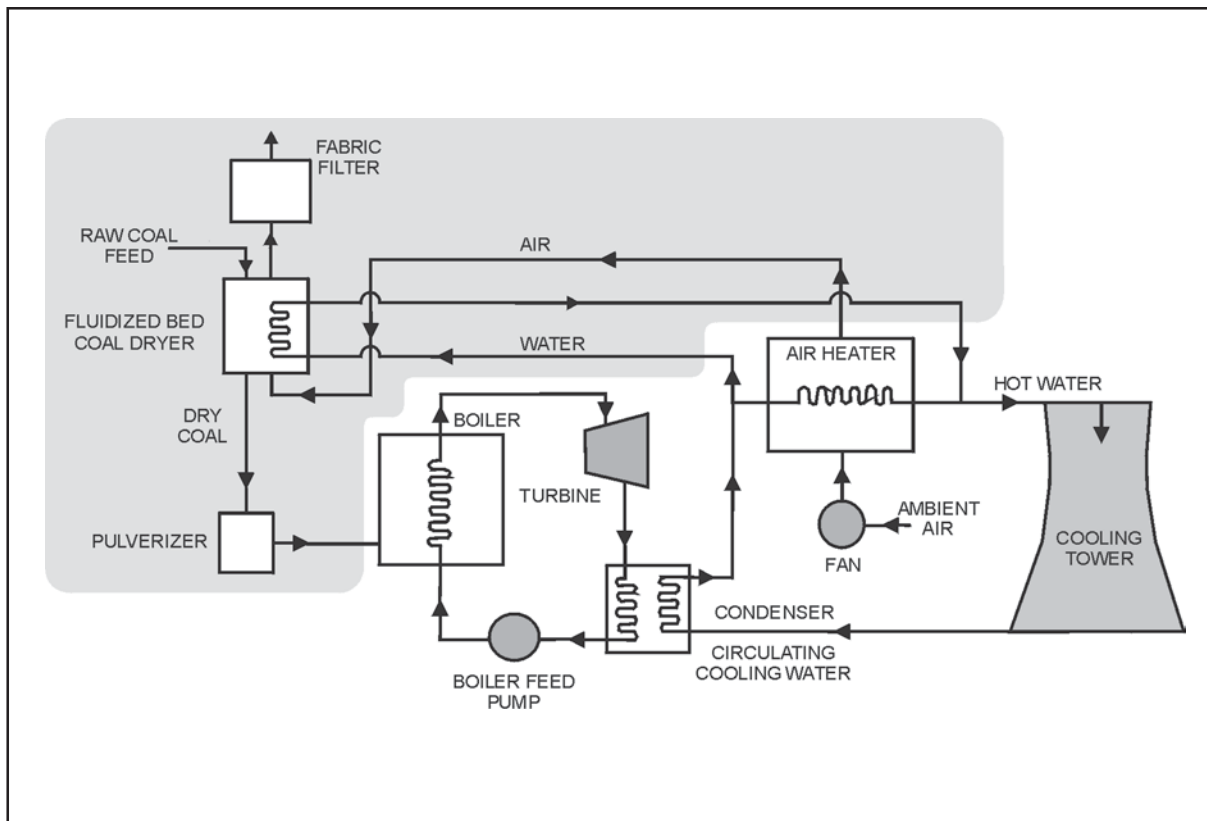

Technology/Project Description

Although current lignite power plants are designed to burn high-moisture coals, a 5 to 15 percentage point reduction in moisture content will result in significant improvements. The benefits of reduced-moisture-content lignite will be demonstrated at the GRE Coal Creek Station. A phased approach will be used. In the first phase, a full-scale prototype dryer module will be designed and built to support operation of a single pulverizer on one of the 546-MW units at the Coal Creek Station. Following successful demonstration of the dryer and the performance improvements as a result of the dryer, GRE will design, construct, and perform full-scale, long-term operational testing of a full suite of dryer modules for full operation of the unit on incrementally dried coal.

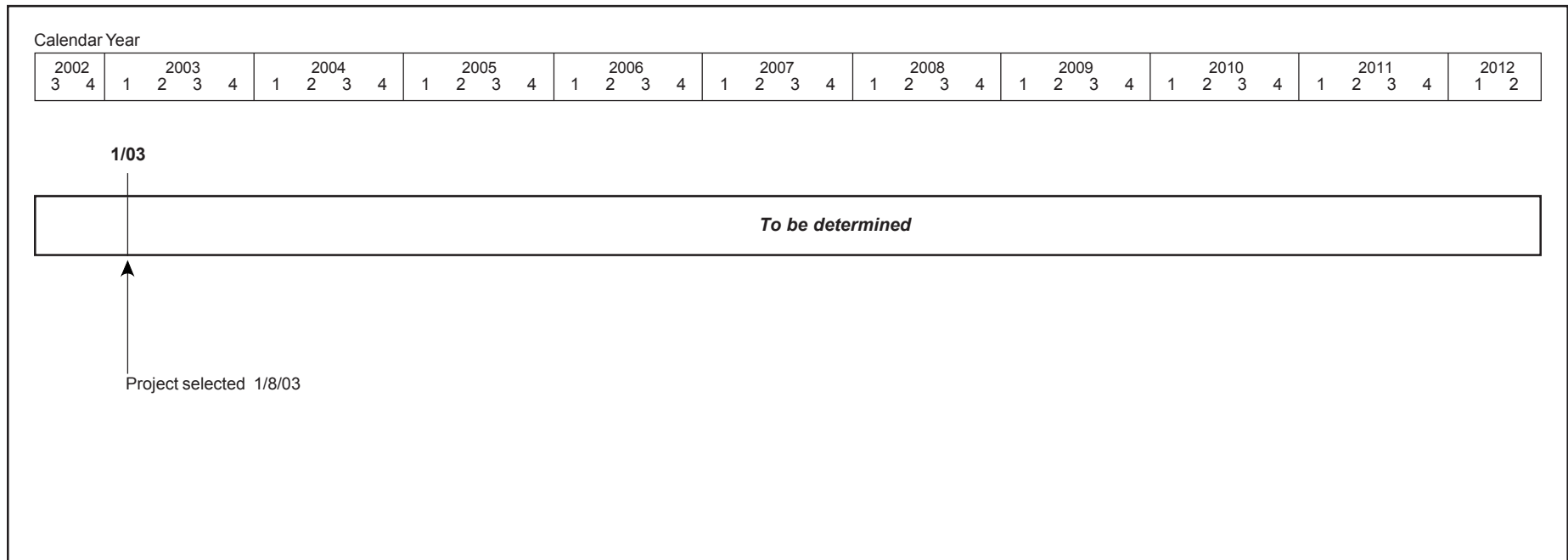

Project Status/Accomplishments

This project was selected for award on January 8, 2003. Negotiations are currently in progress. The cooperative agreement is expected to be issued in late-2003. The project duration is expected to be slightly over three years.

Commercial Applications

This project offers a novel concept for using low-value, often underutilized heat normally available in power plants, to increase the plant’s efficiency, reduce pollution, and improve economics. When demonstrated, this technology could be applied to increase the generating capacity, efficiency, and cost-effectiveness of other units that burn high-moisture coal. Currently in the United States, there are 29 operating plants using lignite coal (15.3 GW) and more than 150 plants burning Powder River Basin (PRB) coals (more than 150 GW), both with inherently high moisture content. Application of this technology could result in a reduction in the emissions from coal-fired power plants because the plants will require less of the dried coal to produce the equivalent amount of power. For example, in this project, the moisture in the lignite

would be lowered from 38% to 29.5% and is estimated to yield a 2.8% efficiency improvement with an attendant benefit of reducing carbon dioxide, sulfur dioxide, and mercury emissions per unit electricity output. This technology could potentially increase the efficiency of plants running on PRB and lignite which represents slightly more than half of the coal electrical generation capacity in the United States.

Gilberton Coal-to-Clean Fuels and Power Co-Production Project

Participant

WMPI PTY., LLC

Additional Team Members

Nexant, Inc.—collaborator

Shell Global Solutions B.V., U.S.—collaborator

Uhde GmbH.—Engineer, technology supplier, and constructor

SASOL Technology Ltd.—collaborator

Location

Gilberton, Schuylkill County, Pennsylvania

Technology

Shell gasifier and Fischer-Tropsch (FT) synthesis

Project Capacity/Production

5,038 bbls/day of ultra-clean fuels and 41 MWe

Coal

Coal-derived wastes, such as anthracite culm

Project Funding

Total	\$612,000,000	100%
DOE Share	\$100,000,000	16
Participant	\$512,000,000	84

Project Objective

To demonstrate gasification of coal wastes to produce a synthesis gas, and in turn electric power, steam, and clean liquid fuels.

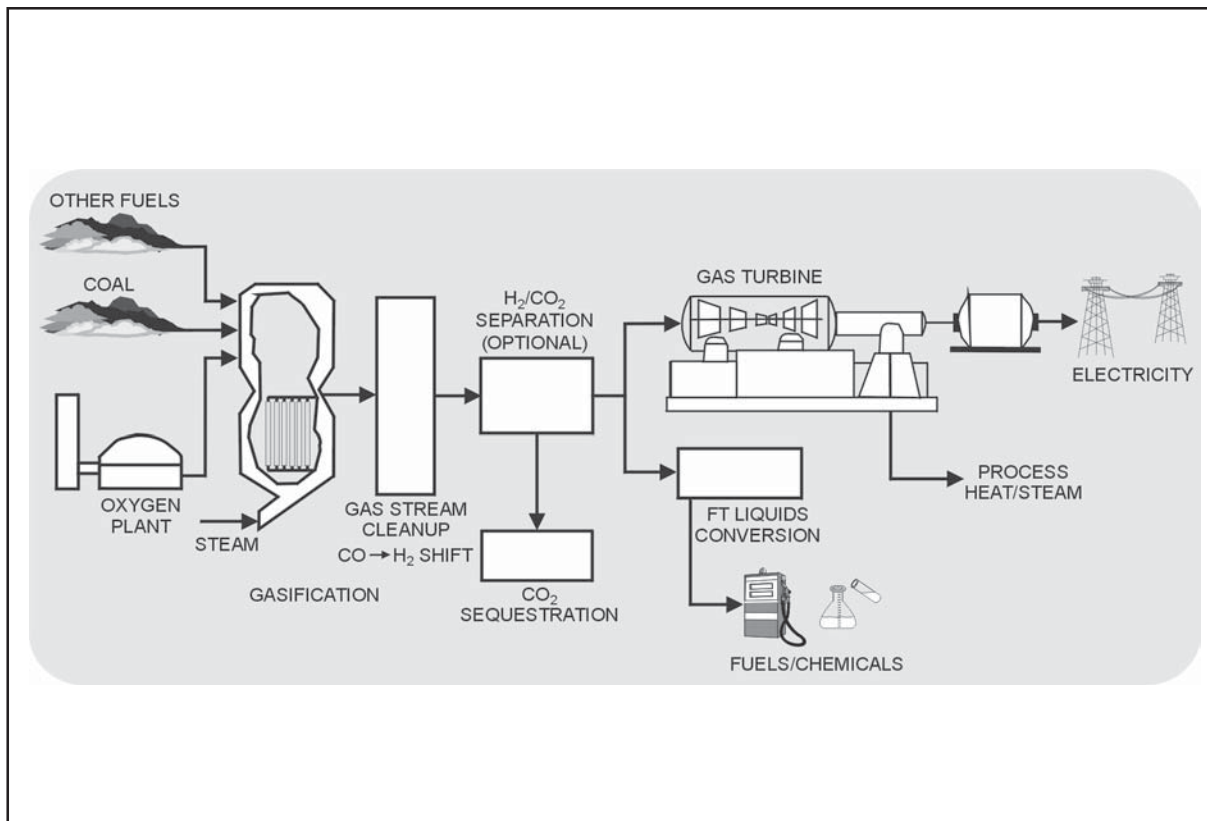

Technology/Project Description

The plant will gasify the coal wastes to produce a synthesis gas of hydrogen and carbon monoxide using Shell's oxygen blown gasifier. A portion of the synthesis gas from the gasification process will be converted into synthetic hydrocarbon liquids via a catalytic chemical process known as FT synthesis. The FT naphtha, kerosene, and diesel fuels, being virtually free of sulfur, nitrogen, and aromatics, are superior to their conventional petroleum counterparts in both end-use and environmental properties. The FT naphtha can either be upgraded to a high-octane, clean reformulated gasoline (RFG) or used as sulfur-free onboard reforming feed for hydrogen fuel-cell-powered vehicle applications. The FT kerosene has a low smoke point and potential application as a niche-market jet fuel. FT diesel fuel has a high Cetane Number

and offers reduced particulate matter, NO_x, hydrocarbon and CO emissions. Other by-products include sulfur and a vitrified material that has a variety of industrial uses.

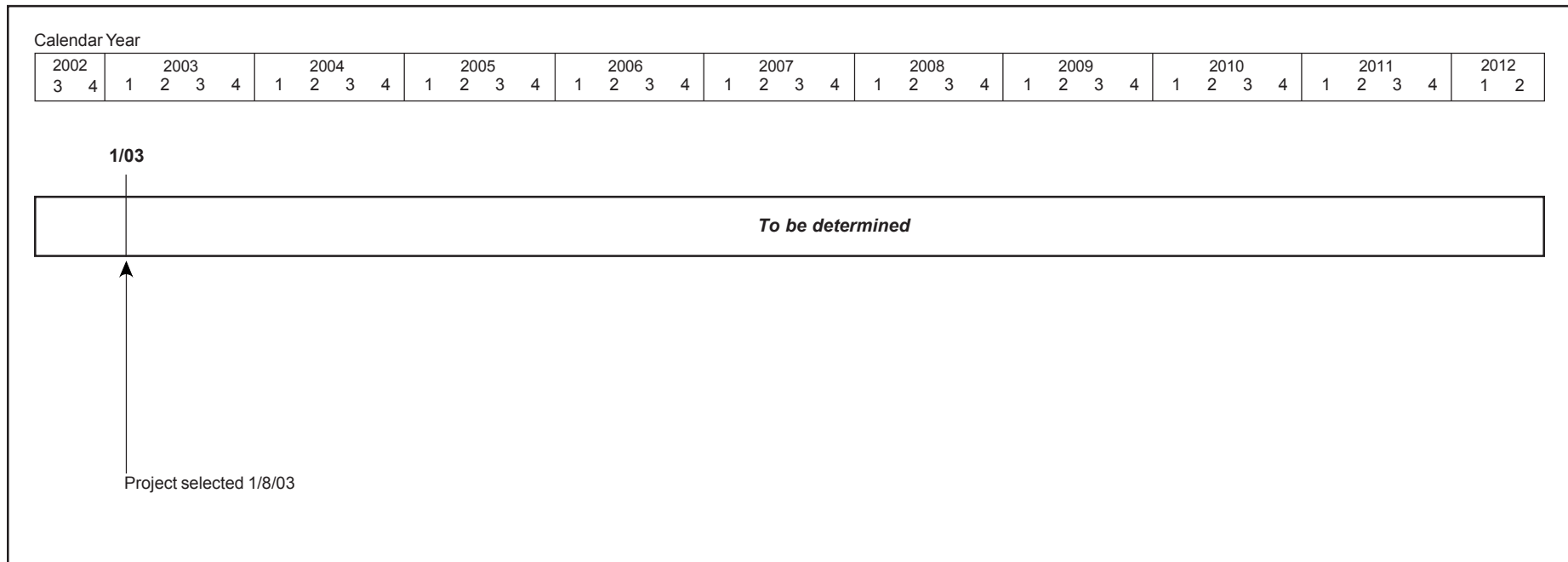

Project Status/Accomplishments

This project was selected for award on January 8, 2003. Negotiations are currently in progress. The cooperative agreement is expected to be issued by late-2003. The project duration is expected to be six years.

Work is continuing on preparing the Environmental Impact Statement. The public scoping meeting was held on May 5, 2003. Other preaward activities, such as securing project financing, preparing an estimate for the lump sum turnkey price, and characterization of the feedstock, are also underway.

Commercial Applications

A primary benefit of this project is that it applies clean coal technology to address a long-standing environmental reclamation issue associated with the mining and production of coal. This project offers a unique integration of several key technologies to, for the first time, convert 4,700 tons/day of coal waste materials (referred to as anthracite culm in this case) into 41 MWe of clean electric power and over 5,000 barrels per day of ultra-clean transportation fuels. This project will process about 1.0

million tons per year of coal waste materials from the Gilberton site. It has been estimated that from past coal mining operation, about 200–300 million tons of this material can be found across Pennsylvania alone. A similar amount is present in Illinois. If successful, this technology could be applied in many regions of the country enabling reclamation of lands where coal wastes are currently stockpiled and significantly reduce waste disposal activities from operating coal mines. The transportation fuels produced will be in the form of ultra-clean, high-cetane diesel fuel from the FT process and contain no sulfur or aromatics. The FT naphtha can be upgraded to clean-burning reformulated gasoline. FT naphtha is also an excellent feedstock for steam cracking for olefin production, or as onboard reforming feed for fuel cell powered vehicles. The proposed process scheme is very flexible. It can use coal, coal wastes, petroleum coke, and biomass alone, or as a blended feedstock to make synthesis gas that can be converted into a variety of beneficial products such as electricity, process heat, transportation fuels and other chemical feedstocks. The combination of the Shell gasifier and the use of the

Rectisol™ process will remove contaminants from the plant's effluent to very low levels. In fact, this stream will be concentrated in carbon dioxide and offers an opportunity for carbon management options beyond this demonstration project. The gross plant efficiency is estimated to be about 45 percent, based on the total energy input and considering the energy value of all the plant's products. The project will bring this country one step closer to energy independence by demonstrating the ability to economically convert domestic waste coal and low-value energy resources into high-value products in an environmentally sound manner. If successful, this project is of sufficient scale to reduce technical, business, and financial risks, clearing the way for subsequent applications.

Advanced Coal Conversion Process Demonstration

Demonstration Operations Completed

Participant

Western SynCoal LLC (formerly Rosebud SynCoal Partnership; a subsidiary of Montana Power Company's Energy Supply Division)

Additional Team Members

None

Location

Colstrip, Rosebud County, MT (adjacent to Western Energy Company's Rosebud Mine)

Technology

Western SynCoal LLC's Advanced Coal Conversion Process for upgrading low-rank subbituminous and lignite coals

Plant Capacity/Production

45 tons/hr of SynCoal® product

Coal

Powder River Basin subbituminous (Rosebud Mine), 0.5–1.5% sulfur, plus tests of other subbituminous coals and lignites

Project Funding

Total	\$105,700,000	100%
DOE	43,125,000	41
Participant	62,575,000	59

Project Objective

To demonstrate Western SynCoal LLC's Advanced Coal Conversion Process (ACCP) to produce SynCoal®, a stable coal product having a moisture content as low as 1%, sulfur content as low as 0.3%, and heating value up to 12,000 Btu/lb.

SynCoal is a registered trademark of the Rosebud SynCoal Partnership.

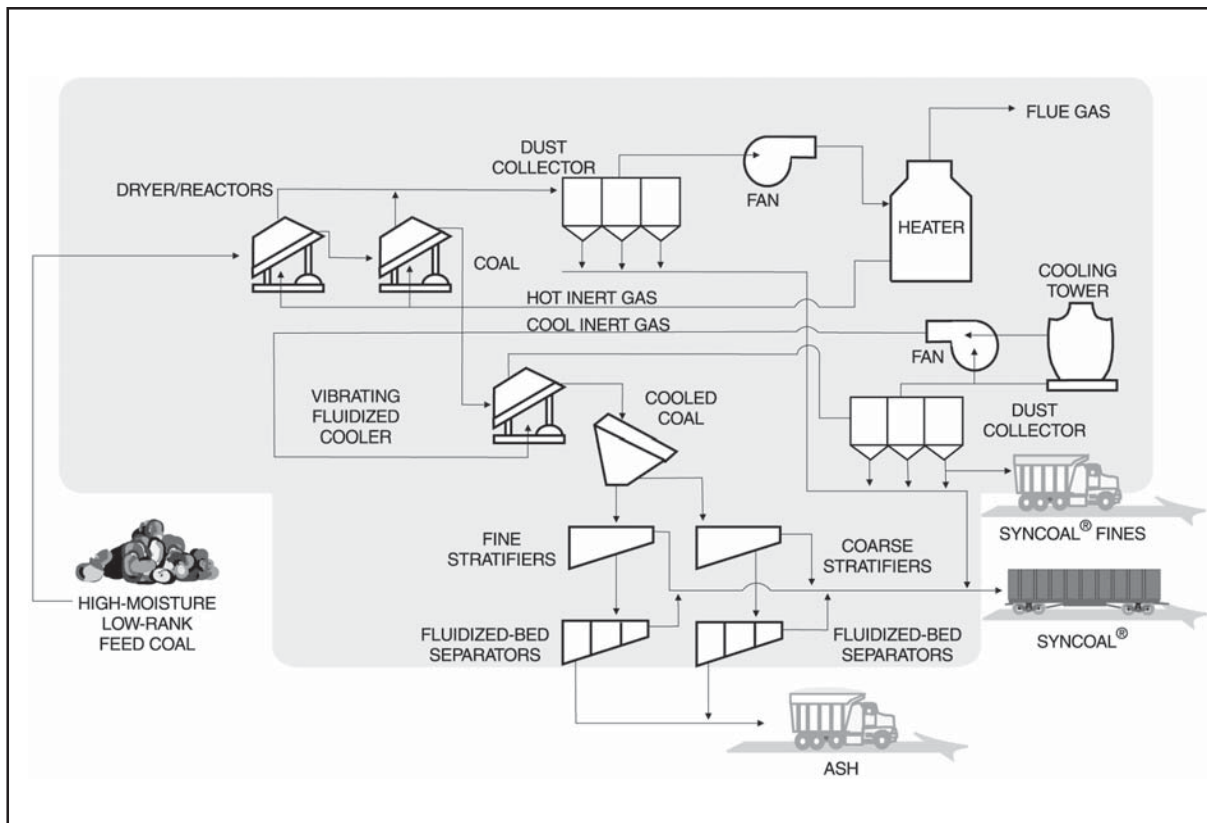

Technology/Project Description

The process demonstrated is an advanced thermal coal conversion process coupled with physical cleaning techniques to upgrade high-moisture, low-rank coals to produce a high-quality, low-sulfur fuel. The raw coal is screened and fed to a vibratory fluidized-bed reactor where surface moisture is removed by heating with hot combustion gas. Coal exits this reactor at a temperature slightly higher than that required to evaporate water and flows to a second vibratory reactor where the coal is heated to nearly 600 °F. This temperature is sufficient to remove chemically bound water, carboxyl groups, and volatile sulfur compounds. In addition, a small amount of tar is released, partially sealing the dried product. Particle shrinkage causes fracturing, destroys moisture reaction sites, and liberates the ash-forming mineral matter.

The coal is then cooled to less than 150 °F by contact with an inert gas in a vibrating fluidized-bed cooler. The cooled coal is sized and fed to deep-bed stratifiers where air pressure and vibration separate mineral matter, including much of the pyrite, from the coal, thereby reducing the sulfur content of the product. The low specific gravity fractions are sent to a product conveyor while heavier fractions go to fluidized-bed separators for additional ash removal.

The fines handling system consolidates the coal fines that are produced throughout the ACCP facility. The fines are gathered by screw conveyors and transported by drag conveyors to a bulk cooling system. The cooled fines are blended with the coarse product, stored in a 250-ton capacity bin until loaded into pneumatic trucks for off-site sales, or returned to the mine pit.

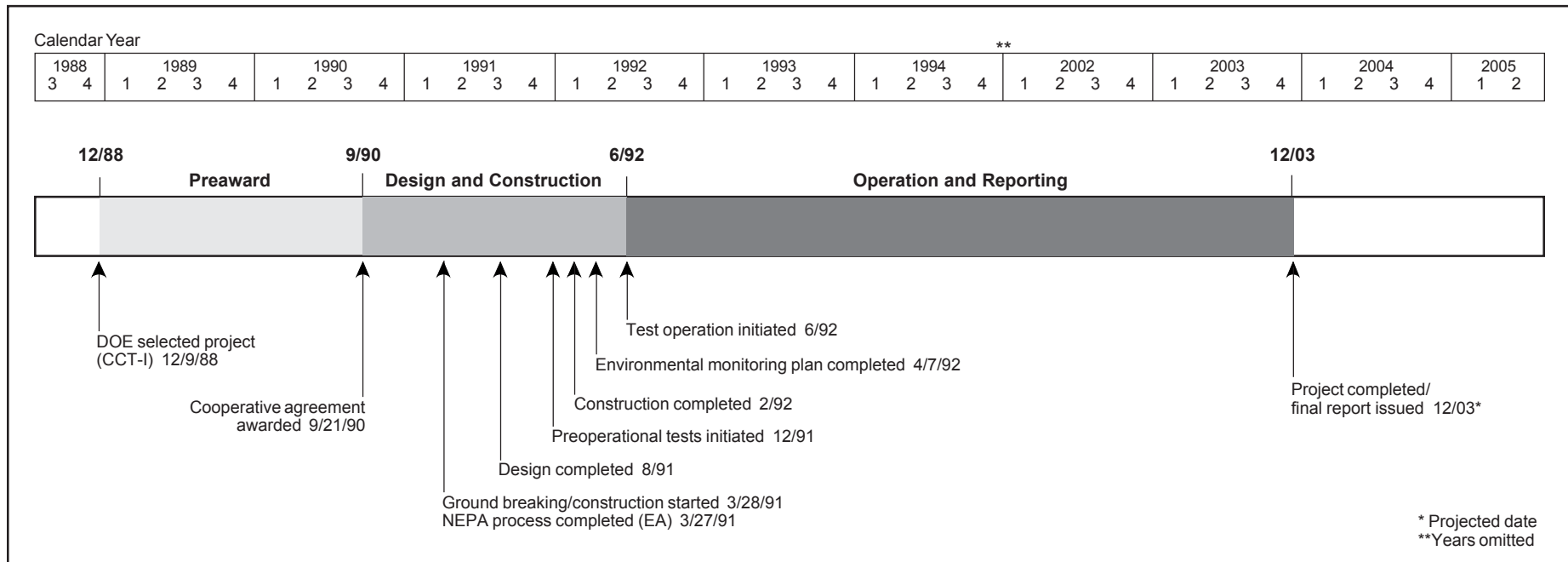

Results Summary

Operational

- During the life of the ACCP project, over 2.8 million tons of raw coal was processed to produce almost 1.9 million tons of SynCoal® products, which included regular, fines, blends, DSE treated, and special characteristic SynCoal® shipped to various customers.
- The product produced was exceptionally close to the design basis product from a chemical standpoint, but did not allow for conventional bulk handling from a physical standpoint due to instability (spontaneous heating) and dustiness.

Environmental

- The measured emissions of PM from the process stack were 0.0259 gr/dscf (2.563 lb/hr) with a limit of 0.031 gr/dscf.
- The measured emissions of NO_x were 4.50 lb/hr (54.5 ppm) compared with a vendor estimated limit of 7.95 lb/hr for controlled emissions and 11.55 lb/hr for uncontrolled emissions.

- The measured emissions of CO were 9.61 lb/hr (191.5 ppm) compared with a vendor estimated limit of 6.46 lb/hr for controlled emissions and 27.19 lb/hr for uncontrolled emissions.
- The measured emissions of SO₂ were 0.227 lb/hr (2.0 ppm) compared with a vendor estimated limit of 7.95 lb/hr for controlled emissions and 20.27 lb/hr for uncontrolled emissions.
- The measured emissions of total hydrocarbons were 2.93 lb/hr (37.1 parts per million).
- The measured emissions of hydrogen sulfide were 0.007 lb/hr (0.12 parts per million).

Economic

- Economic data are not available.

Project Summary

This project demonstrated an advanced, thermal, coal upgrading process, coupled with physical cleaning techniques, that was designed to upgrade high-moisture, low-rank coals to a high-quality, low-sulfur fuel, registered as the SynCoal® process. The coal was processed through three stages (two heating stages followed by an inert cooling stage) of vibrating fluidized-bed reactors that remove chemically bound water, carboxyl groups, and volatile sulfur compounds. After thermal upgrading, the coal is processed in vibrating pneumatic stratifiers to separate the pyrite-rich coal refuse from the SynCoal® product.

The 45-ton-per-hour unit is located adjacent to a unit train load-out facility at Western Energy Company's Rosebud coal mine near Colstrip, Montana. The demonstration plant was sized at about one-tenth the projected throughput of a projected commercial facility.

Operational Performance

During the life of the ACCP project, over 2.9 million tons of raw coal was processed to produce almost 2.0 million tons of SynCoal® products, which include regular, fines, blends, dust stabilization enhancement (DSE) treated, and special characteristic SynCoal® shipped to various customers. See Exhibit 2-4 for annual statistics from the

ACCP plant. The plant posted a perfect worker safety record with no lost time accidents during the entire nine years of operation. When operation ended in 2001, the ACCP had been supplying six commercial customers with SynCoal®.

The product produced has been exceptionally close to the design basis product from a chemical standpoint, but was not acceptable for conventional bulk handling and storage due to instability (spontaneous heating) and dustiness. Due to the instability, SynCoal® had to be stored with an inert gas or in tightly sealed vessels to prevent air infiltration. A CO₂ inert storage system was developed and installed for silo storage of SynCoal®. A significant amount of work has gone into addressing the instability issue. In conjunction with ENCOAL LLC and Amax Coal Company, Western SynCoal researched the effects of different environments and treatments on low-rank coal composition. Specific objectives were to study the explosivity and flammability limits of dust from the conversion process and to identify the causes of spontaneous heating of upgraded coal products. At the time activities were suspended, the development efforts were focused on the use of the Aeroglide Tower Reactor design.

The Aeroglide reactor represents a novel method of allowing process gases to contact the solids in a mechani-

cally gentle environment. Solids are fed to the unit and flow, assisted only by gravity, downward through a system of baffles that gently mix the solids during the migration of the solids from the inlet to the outlet. The flow is controlled using a mass flow discharge valve. Rows of baffles are configured perpendicular to each successive row. Process gases are introduced using alternate horizontally configured baffles and distributed into the solids uniformly. Process gases migrate to adjacent baffles and exit the process bed of solids. The Aeroglide reactor was configured to rehydrate processed SynCoal®, remove the heat of reaction, and partially oxidize the product in an effort to promote product stability. This process scheme was intended to modify the characteristics of the final SynCoal® product allowing traditional transportation techniques to be employed. Results of the testing were promising, but not conclusive.

With regard to the operational performance of the SynCoal® product, three different feedstocks were tested at the ACCP facility—North Dakota lignite, Knife River lignite, and Amax subbituminous coal. Approximately 190 tons of the SynCoal® product produced with the North Dakota lignite was burned at the 250-MWe cyclone-fired Milton R. Young Power Plant Unit No. 1. Testing showed dramatic improvement in cyclone com-

**Exhibit 2-4
ACCP Annual Production Rates**

	1992	1993	1994	1995	1996	1997	1998	1999	2000	2001	Total
Raw Coal Processed (tons)	28,686	157,421	371,447	479,621	369,652	395,450	163,272	419,296	441,379	112,931	2,939,235
Availability (%)	18	50	65	78	65	66	28	70	73	54	58
Forced Outage Rate (%)	68	24	26	13	21	26	8	15	14	36	23
Avg. Feed Rate (ton/hr)	21.1	35.8	64.8	70.1	64.3	68.0	66.0	68.4	69.0	73.0	63.3
SynCoal® Shipped (tons)	5,566	57,927	208,428	315,688	238,766	250,070	97,575	288,650	291,604	76,649	1,811,124

Note: 163,106 tons of fines sold in July 1997.

bustion, improved slag tapping, and a 13% reduction in boiler air flow requirements. In addition, boiler efficiency increased from 82% to over 86%, and the total gross heat rate improved by 123 Btu/kWh.

At the Colstrip plant with two coal-fired power plants, baseline testing at the start of the demonstration indicated that the 330-MWe Unit No. 2 was typically producing 2.9 MWe (net) less than Unit No. 1, a sister unit of comparable capacity. In late Spring 1999, Unit No. 1 was overhauled, resulting in an increase in its average output of 7 MWe (net). With this increase in output, the overhauled Unit No. 1 would have produced 5.4 MWe more than Unit No. 2. However, for the days that SynCoal® was used, Unit No. 2 out-produced the overhauled Unit No. 1 by an average of 7.3 MWe—285.7 MWe versus 278.4 MWe (net)—with 15.0% of the total heat input coming from SynCoal. Furthermore, SynCoal® can be credited for actual 1999 SO₂ emissions reductions for Unit No. 2 of approximately 430 tons, or an 8% reduction, and NO_x emissions reductions of approximately 826 tons, or a 19% reduction, when compared with Unit No. 1 emissions.

Environmental Performance

Western SynCoal originally assumed that SO₂ emissions would have to be controlled by injecting chemical sorbents into the ductwork. Preliminary data indicated that the addition of chemical injection sorbent was not necessary to control SO₂ emissions under the operating conditions.

The coal-cleaning area's fugitive dust was controlled by placing hoods over the fugitive dust sources conveying the dust-laden air to fabric filters. The bag filters effectively removed coal dust from the air before discharge. The Montana Department of Health and Environmental Sciences completed stack tests on the east and west baghouse outlet ducts and the first-stage drying gas baghouse stack in 1993.

A stack emissions survey was conducted in May 1994. The survey determined the emissions of particulates, sulfur dioxide, oxides of nitrogen, carbon monoxide, total hydrocarbons, and hydrogen sulfide from the process stack. The results are shown in Exhibit 2-5.

Economic Performance

Economic data are not available.

Commercial Applications

ACCP has the potential to enhance the use of low-rank western subbituminous and lignite coals. SynCoal® is a viable compliance option for meeting SO₂ emission reduction requirements. SynCoal® is an ideal supplemental fuel for plants seeking to burn western low-rank coals, because the ACCP allows a wider range of low-sulfur raw coals without derating the units.

The project was able to prove the value of SynCoal® through the seven commercial customers serviced during the last few years of operation. The customers represented utility, industrial, and metallurgical applications.

The ACCP has the potential to convert inexpensive, low-sulfur, low-rank coals into valuable carbon-based reducing agents for many metallurgical applications. Furthermore, SynCoal® enhances cement and lime production and provides a value-added bentonite product.

Contacts

Harry Bonner, General Manager
(406) 494-5119
Western SynCoal LLC
120 North Parkmont
Butte, MT 59701
(406) 494-3317 (fax)

Douglas Archer, DOE/HQ, (301) 903-9443
douglas.archer@hq.doe.gov

Joseph B. Renk III, NETL, (412) 386-6406
joseph.renk@netl.doe.gov

References

Technical Progress Reports (1991–2000). Western SynCoal LLC. April 2001, January 2001, November 1999, February 1999, August 1998, May 1997, February 1995, December 1993, and February 1992.

Exhibit 2-5 ACCP Stack Emissions Survey Results

	Limit	Measured
Particulate Matter	0.031 gr/dscf	0.0259 gr/dscf 2.563 lb/hr
Nitrogen Oxides	7.95 lb/hr ^a 11.55 lb/hr ^b	4.50 lb/hr 54.5 ppm
Carbon Monoxide	6.46 lb/hr ^a 27.19 lb/hr ^b	9.61 lb/hr 191.5 ppm
Sulfur Dioxide	7.95 lb/hr ^a 20.27 lb/hr ^b	0.227 lb/hr 2.0 ppm
Total Hydrocarbons as Propane (Less Methane and Ethane)	NA	2.93 lb/hr 37.1 ppm
Hydrogen Sulfide	NA	0.007 lb/hr 0.12 ppm

^a Estimated controlled emissions based on vendor information.

^b Estimated uncontrolled emissions based on vendor information.

Industrial Applications

Clean Power from Integrated Coal/Ore Reduction (CPICOR™)

Participant

CPICOR™ Management Company LLC (a limited liability company composed of subsidiaries of the Geneva Steel Company)

Additional Team Members

Geneva Steel Holdings corporation—cofounder, constructor, host, and operator of unit

Location

Vineyard, Utah County, UT (Geneva Steel Co.'s mill)

Technology

HIsmelt® direct iron-making process

Plant Capacity/Production

3,300 ton/day liquid iron production and 296 MW (gross) of electricity

Coal

Bituminous, 0.5% sulfur

Project Funding

Total	\$1,065,805,000	100%
DOE	149,469,242	14
Participant	916,335,758	86

Project Objective

To demonstrate the integration of direct iron making with the coproduction of electricity using various U.S. coals in an efficient and environmentally responsible manner.

Technology/Project Description

The HIsmelt® process is based on producing hot metal and slag from iron ore fines and non-coking coals. The

HIsmelt is a registered trademark of HIsmelt Corporation Pty Limited.

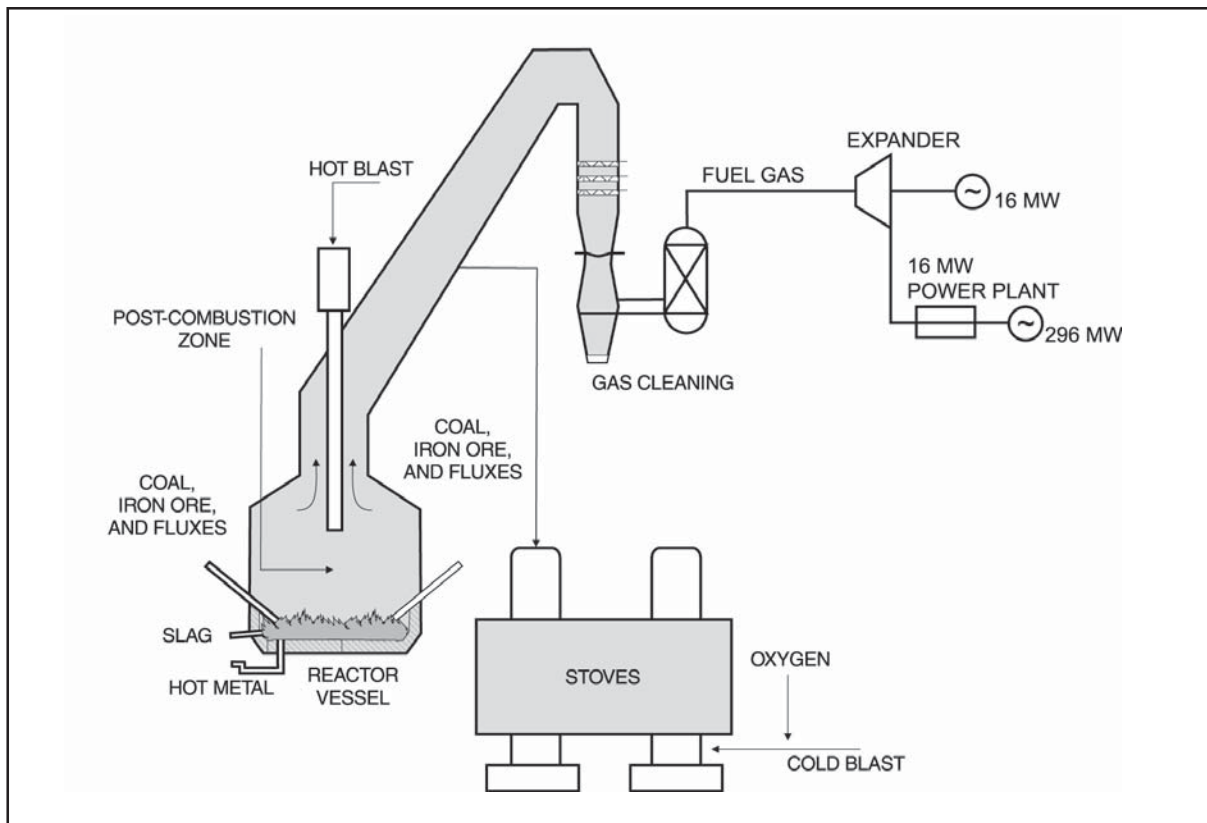

heart of the process is producing sufficient heat and maintaining high heat transfer efficiency in the post-combustion zone above the reaction zone to reduce and smelt iron oxides. The HIsmelt® process uses a vertical smelt reduction reactor, which is a closed molten bath vessel, into which iron ore fines, coal, and fluxes are injected. The coal is injected into the bath where carbon is dissolved rapidly. The carbon reacts with O₂ (from the iron ore) to form CO and metallic iron. Injection gases and evolved CO entrain and propel droplets of slag and molten iron upward into the post-combustion zone. The iron reduction reaction in the molten bath is endothermic; therefore, additional heat is needed to sustain the process and maintain hot metal temperature. This heat is generated by post-combusting the CO and hydrogen from the bath with an O₂-enriched hot air blast from the central top lance. The heat is absorbed by the slag and molten iron droplets, which are returned to the bath by gravity.

Droplets in contact with the gas in the post-combustion zone absorb heat, but are shrouded during the descent by ascending reducing gases, which, together with bath carbon, prevent unacceptable levels of FeO in the slag. The molten iron collects in the bottom of the bath and is continuously tapped from the reactor through a fore-hearth, which maintains a constant level of iron in the reactor. Slag, which is periodically tapped through a conventional blast furnace-type tap hole, is used to coat and control the internal cooling system and reduce the heat loss. Reacted gases, mainly N₂, CO₂, CO, H₂, and H₂O, exit the vessel. After scrubbing, the cleaned gases will be passed through an expander and then combusted to produce electricity. The cleaned gases can also be used to pre-heat and partially reduce incoming iron ore.

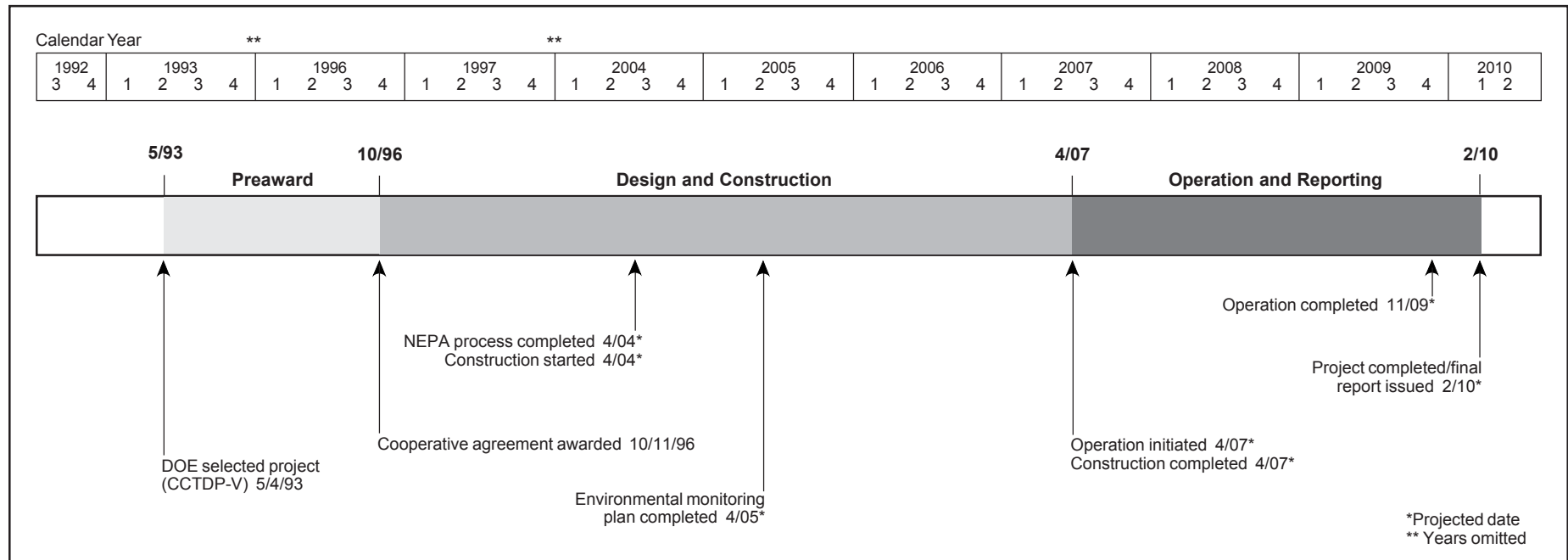

Project Status/Accomplishments

The cooperative agreement was awarded on October 11, 1996. CPICOR™ analyzed the global assortment of new direct iron-making technologies to determine which technology would be most adaptable to western U.S. coals and raw materials. Originally, the COREX® process appeared suitable for using Geneva’s local raw materials; however, lack of COREX® plant data on 100% raw coals and ores prevented its application in this demonstration. Thus, CPICOR™ chose to examine alternatives. The processes evaluated included: AISI direct iron-making, DIOS, Romelt, Tecnoled, Cyclonic Smelter, and HIsmelt®. The HIsmelt® process appears to offer good economic and operational potential, as well as the prospect of rapid commercialization. CPICOR™ has completed testing of two U.S. coals at the HIsmelt® pilot plant near Perth, Australia.

Project definition, preliminary design, and environmental permitting are ongoing. On July 28, 1999, DOE issued a Notice of Intent to prepare an Environmental Impact Statement for the project. A NEPA public scoping meeting was held in Provo, Utah on July 15, 1999.

On February 1, 1999, Geneva Steel Company (CPICOR™ Management Company’s parent corporation) filed a voluntary petition for bankruptcy under Chapter 11 of the United States Bankruptcy Code in the U.S. Bankruptcy Court for the District of Utah. Geneva Steel emerged from Chapter 11 bankruptcy in early 2001 with a restructured balance sheet that enables full participation in this demonstration project.

On January 25, 2002, Geneva Steel LLC filed a voluntary petition under Chapter 11 of the United States Bankruptcy Code. The filing in the United States Bankruptcy Court for Utah, Central Division, was required by the company’s secured lenders as a condition to providing continued access to cash proceeds from the sale of inventory and the collection of accounts receivable. Without such access, Geneva Steel would not have sufficient liquidity to continue its activities and protect its facilities.

CPICOR™ has issued several major contracts for the engineering design of the project. HIsmelt Plc. will perform all preliminary engineering required for Phase I of the project. Lurgi Metallurgy will assist in the design of the direct iron making process, with Rio Tinto (the parent

company of HIsmelt Plc.) providing funding support. Lurgi will also provide engineering services for the co-generation process, including investigation of a turbo expander for power generation.

Commercial Applications

The HIsmelt® technology is a direct replacement for existing blast furnace and coke-making facilities with additional potential to produce steam for power production. Of the existing 79 coke oven batteries, half are 30 years of age or older and are due for replacement or major rebuilds. There are about 60 U.S. blast furnaces, all of which have been operating for more than 10 years, with some originally installed up to 90 years ago. HIsmelt® represents a viable option as a substitute for conventional iron-making technology.

The HIsmelt® process is ready for demonstration. Two pilot plants have been built, one in Germany in 1984 and one in Kwinana, Australia in 1991. Through test work in Australia, the process has been proven—operational control parameters have been identified and complete computer models have been successfully developed and proven.

Commercial Demonstration of the Manufactured Aggregate Processing Technology Utilizing Spray Dryer Ash

Participant

Universal Aggregates, LLC (a joint venture between CONSOL Energy, Inc. and SynAggs, Inc.)

Additional Team Members

CONSOL Energy, Inc.—development and engineering
P.J. Dick, Inc.—project management and construction
SynAggs, LLC—marketing

Location

King George County, VA (Birchwood Power Facility)

Technology

Aggregate manufacturing plant using by-products from spray dryer flue gas desulfurization (FGD) scrubbers

Plant Capacity/Production

150,000 tons/year of lightweight aggregate

Coal

Bituminous, 0.9% sulfur

Project Funding

Total	\$19,581,734	100%
DOE	7,224,000	37
Participant	12,357,734	63

Project Objective

Universal Aggregates LLC will design, build, and operate an aggregate manufacturing plant that converts 115,000 tons/year of spray dryer by-products into 167,000 tons/year of lightweight aggregate that can be used in the manufacture of masonry blocks or lightweight concrete.

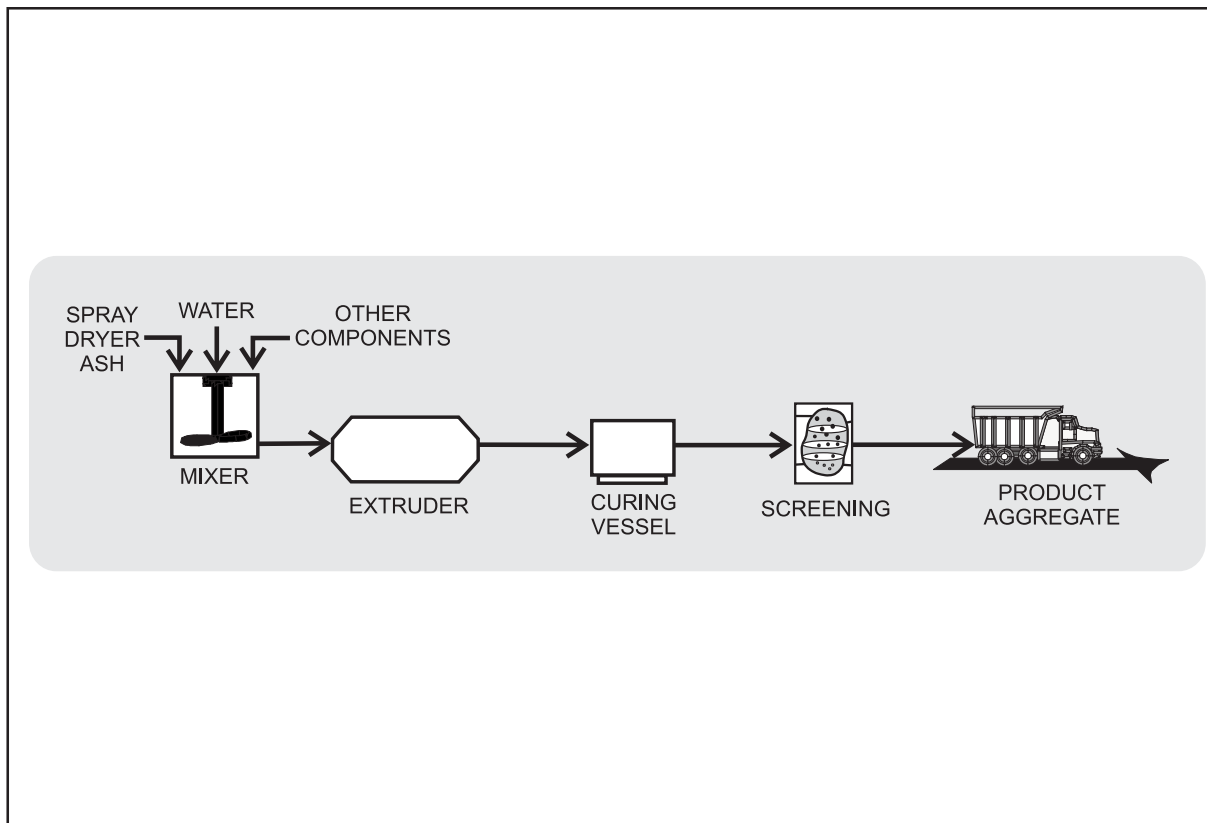

Technology/Project Description

Flue gas desulfurization systems, used to lower sulfur emissions from coal plants, often produce a type of sludge that is landfilled; only 18% of FGD residue is recycled. Much of that 18% pertains to recycling by-products from wet FGD systems or scrubbers. Universal Aggregates' process can be used to recycle the by-products from wet or dry scrubbers. This would reduce plant disposal costs while reducing the environmental drawbacks of landfilling.

The Birchwood facility will transform 115,000 tons/year of spray dryer by-products that are currently being disposed of in an off-site landfill into 167,000 tons/year of a useful product: lightweight aggregates that can be used to manufacture lightweight masonry blocks or lightweight concrete.

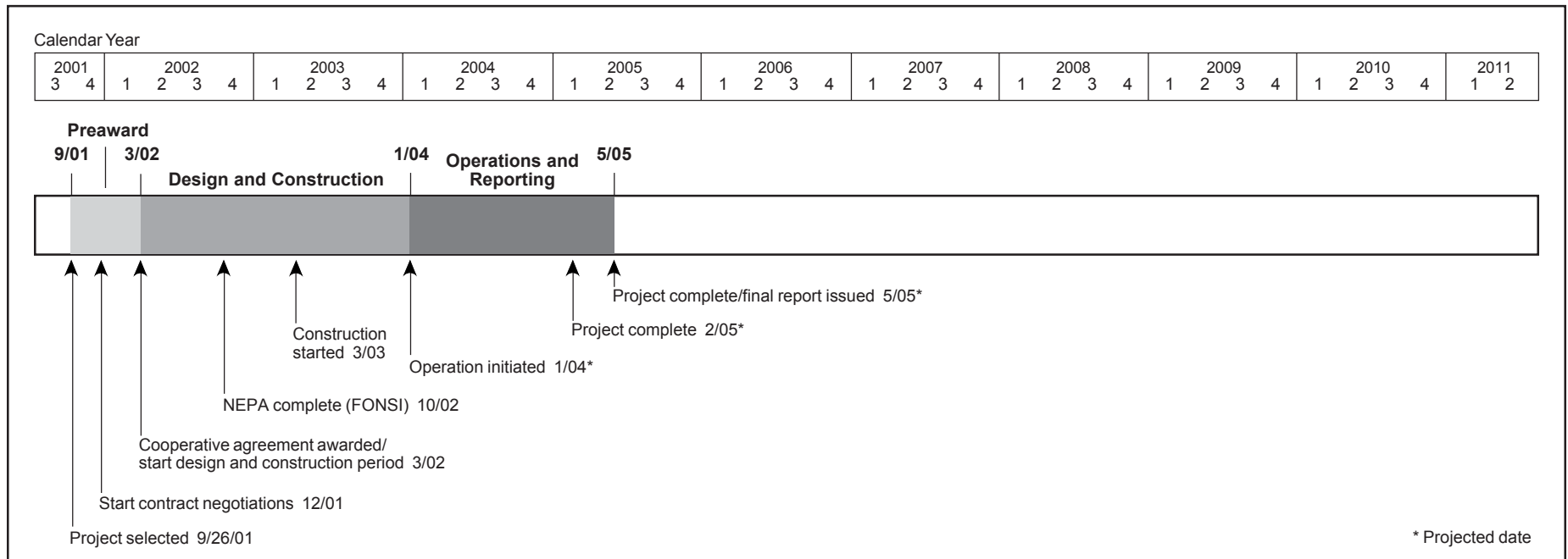

Project Status/Accomplishments

The project was selected for award on September 26, 2001. The cooperative agreement was awarded on November 25, 2002. The National Environmental Policy Act process was completed on October 2, 2002, with the issuance of a Finding of No Significant Impact. Start of construction was approved by DOE on March 24, 2003. The plant will begin operation in 2004.

Commercial Applications

There are currently twenty-one spray dryer facilities operating in the United States that produce an adequate amount of spray dryer by-product to economically justify the installation of a lightweight aggregate manufacturing facility. Industry sources believe that as additional scrubbing is required, dry FGD technologies will be the technology of choice. Letters from potential lightweight aggregate customers indicate that there is a market for the product once the commercialization barriers are eliminated by this demonstration project.

Advanced Multi-Product Coal Utilization By-Product Processing Plant

Participant

University of Kentucky Research Foundation

Additional Team Members

LG&E Energy Corporation—collaborator

University of Kentucky Center for Applied Energy Research (CAER)—collaborator

Location

Ghent, Carroll County, Kentucky (Kentucky Utilities Company's Ghent Power Station)

Technology

University of Kentucky CAER's hydraulic classification froth flotation process

Project Capacity/Production

800 tons per day of coal ash input

Coal

Pittsburgh coal

Project Funding

Total	\$8,916,739	100%
DOE Share	\$4,450,163	50
Participant	\$4,466,576	50

Project Objective

To demonstrate an advanced coal ash beneficiation processing plant at the 2,200-MW Ghent Power Plant that will produce (1) pozzolan (cementitious material), high-grade, lightweight aggregate; (2) graded fill sand; (3) high-quality polymeric filler; and (4) recycled carbon fuel.

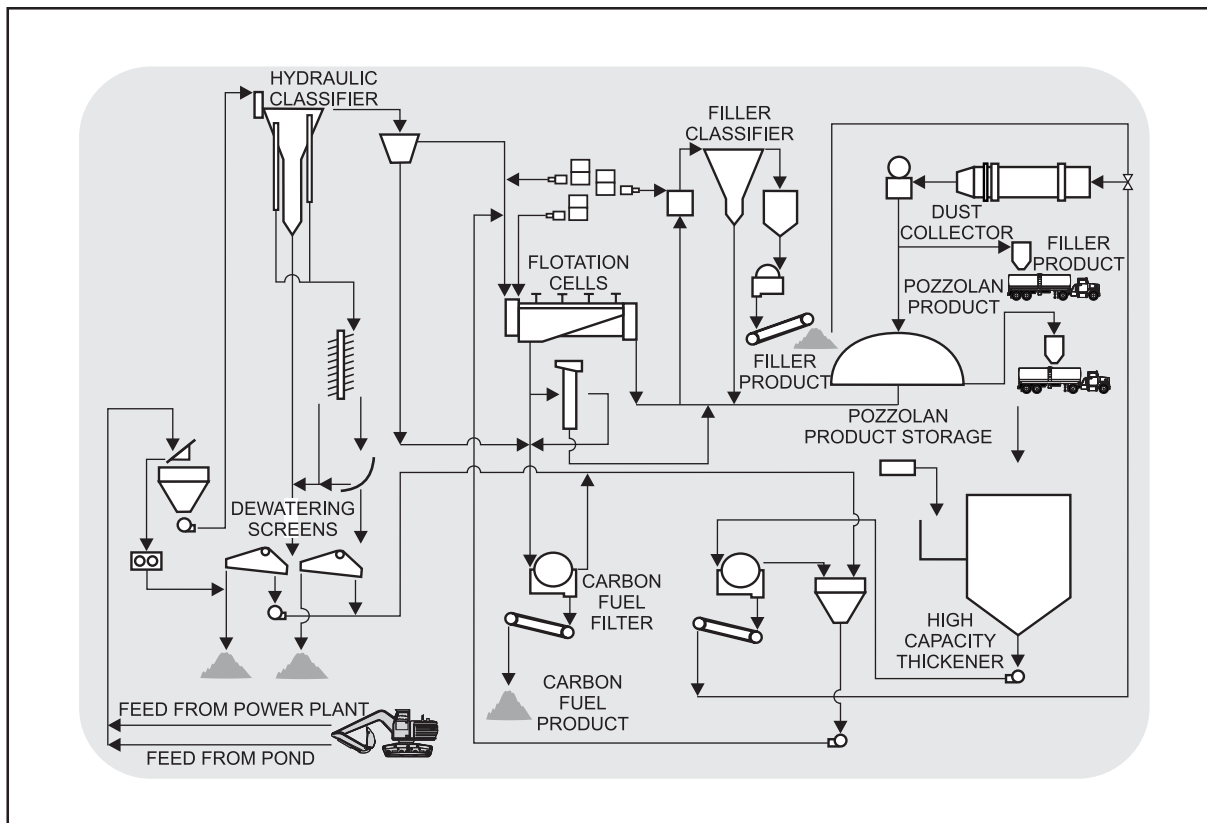

Technology/Project Description

The process is based upon a hydraulic classification and froth flotation technology developed at the University of Kentucky CAER. The technology can process ash stored in disposal ponds or directly from the plant. Raw feed is classified into a pozzolan stream (-200 mesh) and a coarse stream (+200 mesh). The coarse materials are further classified and concentrated into a sand product and coarse carbon product by spiral concentrators. The fine pozzolan stream is treated with a reagent system, the fine carbon removed via froth flotation, and the pozzolan concentrated, filtered, and dried. A small stream from the froth cell is further processed hydraulically to produce a fine particle suitable for use in a number of applications, including a polymer additive.

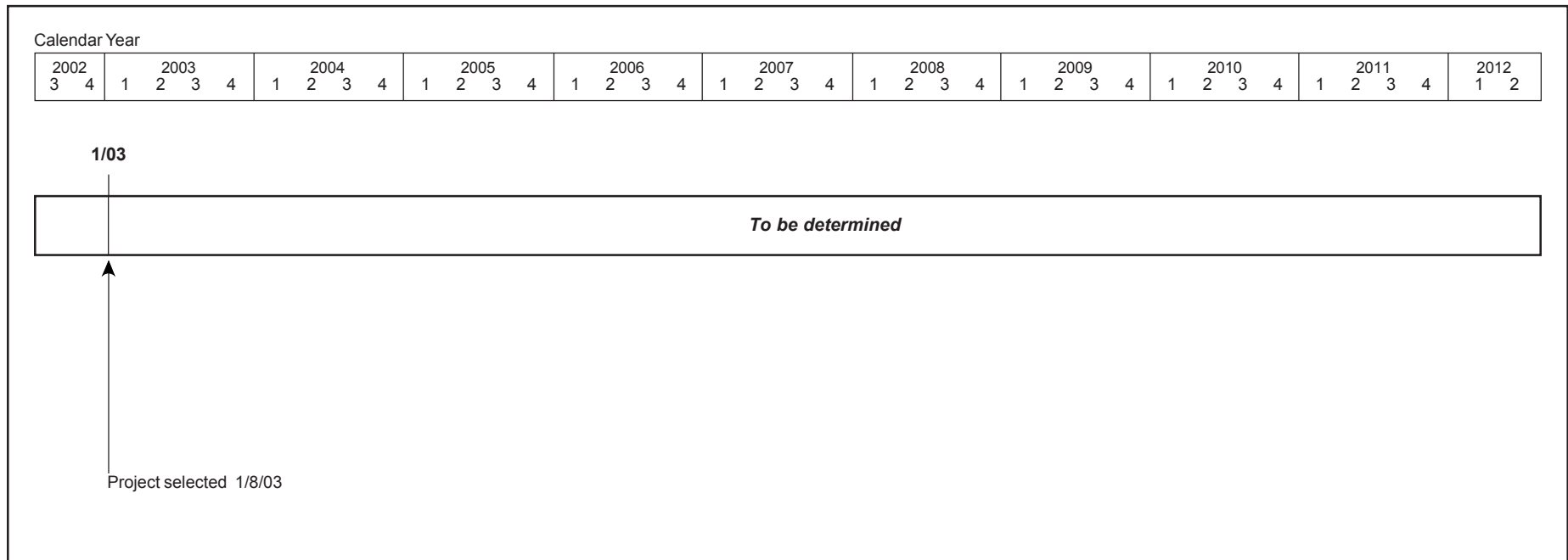

Project Status/Accomplishments

The project was selected for award on January 8, 2003. Negotiations are currently underway. The cooperative agreement is expected to be awarded by late-2003. The estimated project duration is about four years.

Commercial Applications

Throughout the United States, many coal-fired power plants utilize ash-settling ponds and in many cases are required to pay for offsite landfill disposal. This project addresses the use of all of the coal utilization by-products from the plant to produce salable and valued products. Finding a beneficial use of these materials will reduce the need for the creation of new ash settling ponds and extend the life of existing ponds.

One of the important benefits associated with this project is that the 156,000 tons per year of high-quality pozzolan, to be produced from coal by-products, will displace an equivalent amount of portland cement. Manufacturing portland cement results in release of approximately 1 ton of CO₂ per ton of cement produced. As such, this project represents a potential greenhouse gas offset. Cement mak-

ing currently releases about 47 million tons per year of CO₂ in the U.S., making it one of the highest generators of CO₂ of any industrial process. Therefore, utilization of existing coal ash for this purpose offers a new pathway for reducing future CO₂ emissions related to the production of cement.

Western Greenbrier Co-Production Demonstration Project

Participant

Western Greenbrier Co-Generation, LLC

Additional Team Members

Alstom Power, Inc.—technology supplier

Hazen Research, Inc.—technology supplier

Parsons E&C—turn-key constructor

Hazen Research Labs—Technology Supplier

Midway Environmental Associates—Technology Supplier

Location

Rainelle, Greenbrier County, West Virginia

Technology

Alstom Power fluidized-bed combustion and WoodBrik™ technology

Project Capacity/Production

85 MW and structural bricks

Coal

Bituminous waste

Project Funding

Total	\$215,000,000	100%
DOE Share	\$107,500,000	50
Participant	\$107,500,000	50

Project Objective

To demonstrate integrated co-production of 85 MW of power and simultaneous manufacture of structural bricks certified to meet insulation and load-bearing specification requirements, or to produce Class “C” fly ash for concrete applications.

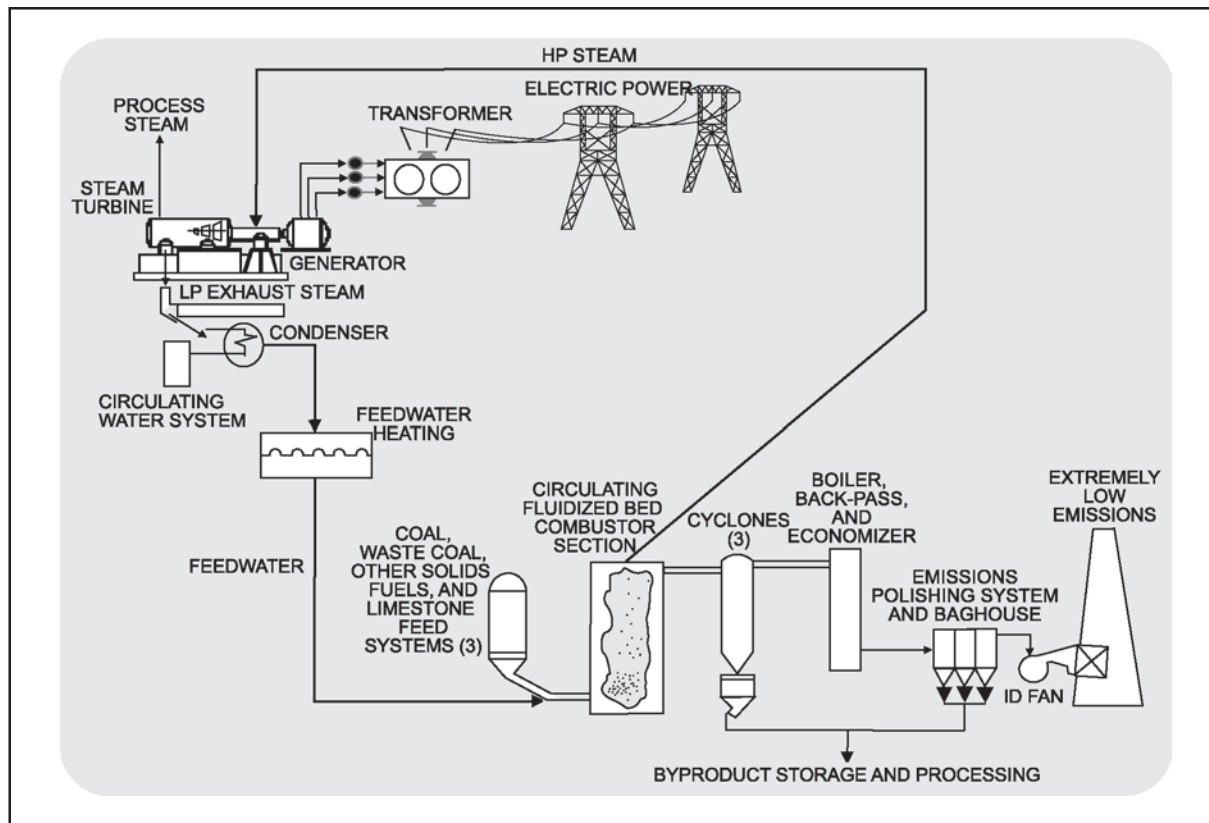

Technology/Project Description

The co-generating power plant uses a novel circulating fluidized bed combustion (CFB) type of boiler incorporating an inverted cyclone to raise steam to power a conventional steam turbine generator. The CFB boiler island is expected to allow a 30–40% smaller footprint, and reduction in steel tonnage by up to 60% as compared to a conventional CFB system. The plant will burn waste coal from a 4 million ton waste coal pile at Anjean and other regional sources. Ash produced from the coal combustion is divided into two streams. Bottom ash and a small portion of the fly ash is collected and returned to the waste coal pile. The mildly alkaline nature of the ash assists in neutralizing the acid runoff from the wastepile, thus alleviating a significant environmental problem. Most of the fly ash is calcined in a kiln, with added limestone, to convert it to a chemical and physical form that renders it

useful for production of structural building products or Class “C” fly ash for concrete applications. A particular patented product, Woodbrik™, has been selected for co-production at the Western Greenbrier Co-Generation facility. The Woodbrik™ is manufactured from converted ash and wood waste into building blocks. The power plant is envisioned to be an anchor tenant in a planned environmentally balanced industrial park (Eco-Park), which will build on the synergistic relationship to the clean-coal power generation system. Steam generated in the boiler or heat from the power plant closed loop cooling system would be used to supply other tenants in the Eco-Park.

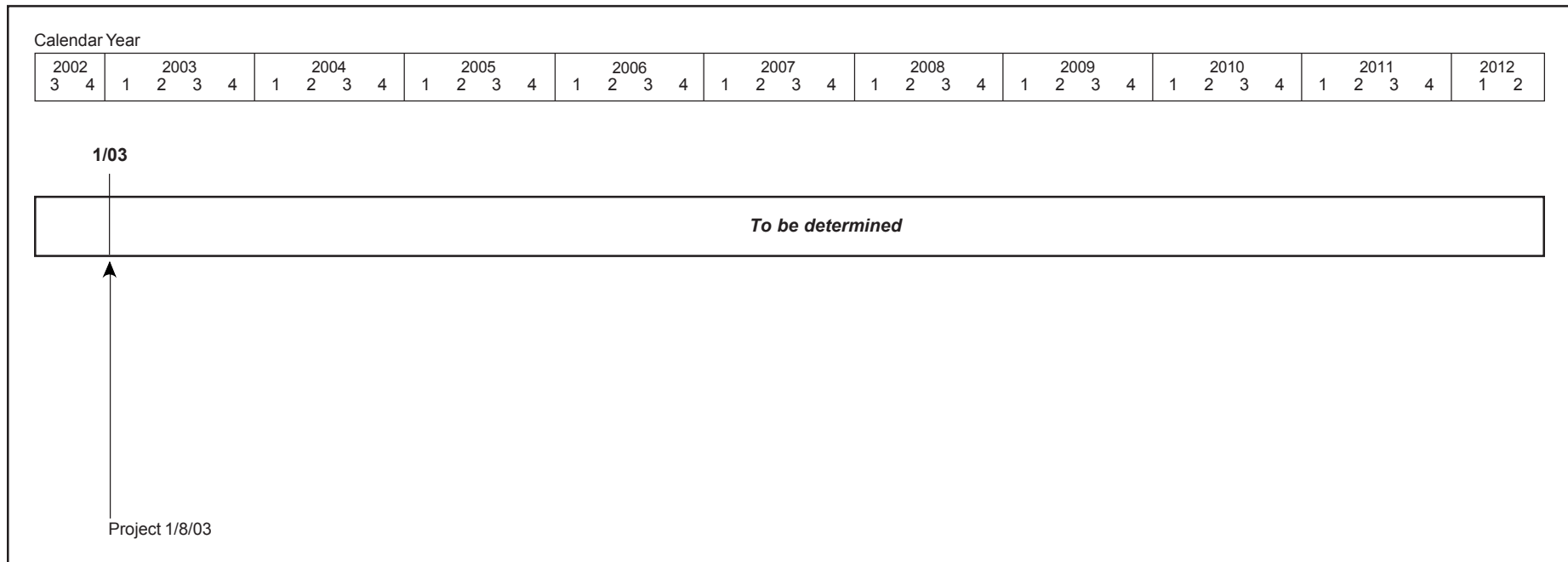

Project Status/Accomplishments

The project was selected for award on January 8, 2003. Negotiations are currently underway. The cooperative agreement is expected to be awarded late-2003. The project is expected to last less than two years.

Commercial Applications

A primary benefit of this project is the application of clean coal technologies to improve industrial ecology by employing advanced multi-pollutant control systems, addressing environmental remediation of coal wastes, and using coal, coal wastes and by-products to produce power, process heat and other industrial products. This project offers a unique integration of technologies to convert 1,610 tons/day of coal waste materials that resulted from past mining operations, commonly referred to as “gob,” and 220 tons/day of freshly mined coal, into 75 MW of electricity, 20,000 pounds/hour of steam for industrial use and district heating, 300 tons/day of structural bricks and 970 tons/day of alkaline ash material suitable for use in remediating acid mine drainage. If successful, this technology and integrated approach could be applied to many regions of the country to re-

claim contaminated land where waste coal is currently stockpiled and to significantly reduce waste disposal activities from operating coal mines. For example, West Virginia alone contains about 400 million tons of waste coal. The advanced compact CFB power plant incorporates SO_x, NO_x, particulate, and mercury missions controls and reduces the standard “footprint” of such plants by 40%. The compact nature of the new system will also reduce structural steel and related construction costs for the boiler system by up to 60%. In addition, the simplified construction process planned for the boiler is expected to result in safer construction practices and a shortened construction time. Employing a Rankine steam cycle for energy conversion (thermal to electricity), this boiler’s targeted reheat steam cycle configuration (1,800 psig/1,000 °F/1,000 °F) is deemed aggressive for a power plant of this size, particularly one that uses waste feedstocks. This plant attempts to maximize power generation efficiency, reduce CO₂ emissions, and conserve water resources, while co-producing steam for commercial and industrial uses.

Aside from the novel power plant design, the project will convert coal waste and other refuse into valuable products, including the production of 75 MW of electricity, alkaline ash for environmental remediation, steam for industrial uses (hardwood drying) and district heating, and co-production of structural bricks. This demonstration will also result in high-quality, long-term employment at the power plant and the related “Eco-Park.” Successful integration of these technologies and the development of this facility can serve as a model for other state and local governments interested in remediating similar refuse sites in the United States and abroad.

3. Completed Projects

Introduction

Of the 36 CCTDP projects, 31 projects have been completed. The following is a summary of the accomplishments from the CCTDP.

Environmental Control Devices

The CCTDP SO₂ control projects (all of which are completed) provided technologies that essentially removed SO₂ control as a technical issue for all manner of existing plants. Advanced wet flue gas desulfurization projects demonstrated in the CCTDP redefined the state-of-the-art for sorbent-based scrubbers. These advanced scrubbers nearly halved capital and operating costs, increased SO₂ removal to 95 percent or more, produced salable by-products instead of wastes, and reduced plant efficiency losses through high-capture-efficiency devices. A portfolio of relatively low-capital-cost sorbent injection technologies demonstrated SO₂ removal up to 90 percent for older, smaller, space-constrained plants.

The CCTDP NO_x control projects (all of which are completed) combined to provide technologies for all major boiler types that enabled industry to cost-effectively comply with 1996 and 2000 emission standards under the Clean Air Act Amendments of 1990. Several of the projects provided valuable real-time data inputs to the ongoing regulatory development process. The projects succeeded in completing development and producing commercially offered low-NO_x burners for all major boiler types except cyclone boilers. For the cyclone boilers, which were not conducive to burner modification or replacement, coal- and gas-reburning NO_x control technologies were developed. In addition

to these combustion modification techniques, projects included demonstration of selective catalytic reduction (SCR) and selective non-catalytic reduction (SNCR) post-combustion technologies. Both SCR and SNCR complement combustion modification for deeper NO_x reduction. Together, these technologies provide the technical foundation for the drive to near-zero emissions in the 21st century.

The multi-pollutant (combined NO_x/SO₂) control projects (all of which are completed) encompass those technologies that combine previously described control methods and those that apply other synergistic techniques. Three of the projects combined low-NO_x burners or gas reburning with sorbent injection. Another project combined low-NO_x burners with SNCR to enhance performance along with a unique space-saving wet scrubber. The balance of the six projects used other synergistic methods.

Summaries of the completed environmental control projects are shown in Exhibits 3-1, 3-2, and 3-3.

Advanced Electric Power Generation

Most of the advanced electric power generation projects under the CCTDP have been completed. These projects have made significant contributions to improving the environmental, operational, and economic performance of coal-based power systems. A key utility-sponsored demonstration, supported by a consortium of power generators and the Electric Power Research Institute (EPRI), provided the technical foundation and impetus for rapid commercialization of utility-scale atmospheric circulating fluidized-bed combustion technology. In another project, a major utility successfully undertook a four-year campaign to transform pressurized fluidized-bed combustion technology into a viable commercial design. Two integrated gasification com-

bined-cycle (IGCC) projects documented here represent pioneering efforts to bring next-generation power systems into mainstream commercial markets. All of the advanced electric power generation projects but three are completed.

A summary of the completed advanced electric power projects is shown in Exhibit 3-4.

Coal Processing for Clean Fuels

The completed coal processing for clean fuels projects under the CCTDP have demonstrated (1) the feasibility of producing clean high-energy-density solid and liquid fuels from low-rank coals; (2) the cost-effective co-production of methanol in association with an IGCC plant; and (3) computer-based programs for assessing impacts of various coals and coal blends on plant operations. All of the coal processing projects but one are completed.

A summary of the completed coal processing for clean fuels projects is shown in Exhibit 3-5.

Industrial Applications

One of the major accomplishments coming out of the industrial application sector of the CCTDP was successful demonstration of a process that enabled displacement of a significant amount of coke with coal in steel production. Other projects contributed to furthering coal use in the industrial sector. All of the industrial projects but one are completed.

A summary of the completed industrial applications projects is shown in Exhibit 3-6.

Exhibit 3-1
Completed CCTDP SO₂ Control Technology Projects

Project	Process	Coal Sulfur Content	SO₂ Reduction	Page
10-MWe Demonstration of Gas Suspension Absorption	Spray dryer—vertical, single-nozzle reactor with integrated sorbent particulate recycle (lime sorbent)	2.6–3.5%	60–90%	3-12
Confined Zone Dispersion Flue Gas Desulfurization Demonstration	Sorbent injection—in-duct lime sorbent injection and humidification	1.2–2.5%	50%	3-16
LIFAC Sorbent Injection Desulfurization Demonstration Project	Sorbent injection—furnace sorbent injection (limestone) with vertical humidification vessel and sorbent recycle	2.0–2.8%	70%	3-20
Advanced Flue Gas Desulfurization Demonstration Project	AFGD—cocurrent flow, integrated quench absorber tower, and reaction tank with combined agitation/oxidation (gypsum by-product)	2.25–4.5%	94%	3-24
Demonstration of Innovative Applications of Technology for the CT-121 FGD Process	AFGD—forced flue gas injection into reaction tank (Jet Bubbling Reactor [®]) for combined SO ₂ and particulate capture (gypsum by-product)	1.2–4.3%	90+%	3-28

Exhibit 3-2
Completed CCTDP NO_x Control Technology Projects

Project	Process	Boiler Size/ Type	NO_x Reduction	Page
Demonstration of Advanced Combustion Techniques for a Wall-Fired Boiler	LNB/AOFA—advanced LNB with separated AOFA and artificial intelligence controls	500 MWe/wall	68%	3-34
Demonstration of Coal Reburning for Cyclone Boiler NO _x Control	Coal reburning—30% heat input	100 MWe/cyclone	52–55%	3-38
Full-Scale Demonstration of Low-NO _x Cell Burner Retrofit	LNB—separation of coal and air ports on plug-in unit	605 MWe/cell burner	47–60%	3-42
Evaluation of Gas Reburning and Low-NO _x Burners on a Wall-Fired Boiler	LNB/gas reburning/AOFA—13–18% gas heat input	172 MWe/wall	37–66%	3-46
Micronized Coal Reburning Demonstration for NO _x Control	Coal reburning—14% heat input (tangentially fired) and 17% heat input (cyclone)	148 MWe/tangential 50 MWe/cyclone	29% 59%	3-50
Demonstration of Selective Catalytic Reduction Technology for the Control of NO _x Emissions from High-Sulfur, Coal-Fired Boilers	SCR—eight catalysts with different shapes and chemical compositions	8.7 MWe/tangential (slip stream)	80%	3-54
180-MWe Demonstration of Advanced Tangentially Fired Combustion Techniques for the Reduction of NO _x Emissions from Coal-Fired Boilers	LNB/AOFA—advanced LNB with close-coupled and separated overfire air	180 MWe/tangential	37–45%	3-58

Exhibit 3-3
Completed CCTDP Multi-Pollutant Control Technology Projects

Project	Process	% Sulfur	SO₂/NO_x Reduction	Page
SNOX™ Flue Gas Cleaning Demonstration Project	SCR/oxidation catalyst/sulfuric acid condenser—synergistic catalyst effect and no solid waste	2.8%	95%/94%	3-64
LIMB Demonstration Project Extension and Coolside Demonstration	LNB/sorbent injection—furnace and duct injection, calcium-based sorbents (LIMB) and calcium/sodium based sorbents (Coolside)	1.6–3.8%	45–70%/40–50%	3-68
SOx-NOx-Rox Box™ Flue Gas Cleanup Demonstration Project	SCR/high-temperature baghouse/sorbent injection—SCR in high-temperature filter bag and calcium- and sodium-based sorbent injection	3.7%	80–90%/90%	3-72
Enhancing the Use of Coals by Gas Reburning and Sorbent Injection	Gas reburning/sorbent injection (GR-SI)—calcium-based sorbents used in duct injection	3.0%	53–66%/66–67%	3-76
Milliken Clean Coal Technology Demonstration Project	LNB/SNCR/wet scrubber—sorbent additive and space-saving, durable scrubber design	1.5–4.0%	90–98%/39%	3-80
Integrated Dry NO _x /SO ₂ Emissions Control System	LNB/SNCR/sorbent injection—calcium- and sodium-based sorbents used in duct injection	0.4%	70%/62–80%	3-84

Exhibit 3-4
Completed CCTDP Advanced Electric Power Generation Technology Projects

Project	Process	Size	Page
Fluidized-Bed Combustion			
Tidd PFBC Demonstration Project	Pressurized bubbling fluidized-bed combustion	70 MWe	3-90
Nucla CFB Demonstration Project	Atmospheric circulating fluidized-bed combustion	110 MWe (gross); 100 MWe (net)	3-94
Integrated Gasification Combined Cycle			
Piñon Pine IGCC Power Project	Air-blown, fluidized-bed gasifier with hot gas cleanup	107 MWe (gross); 99 MWe (net)	3-100
Tampa Electric Integrated Gasification Combined-Cycle Project	Oxygen-blown, entrained-flow gasifier with hot and cold gas cleanup	315 MWe (gross); 250 MWe (net)	3-104
Wabash River Coal Gasification Repowering Project	Oxygen-blown, two-stage entrained-flow gasifier with cold gas cleanup	296 MWe (gross); 262 MWe (net)	3-108
Advanced Combustion/Heat Engines			
Healy Clean Coal Project	Advanced slagging combustor, spray dryer with sorbent recycle	50 MWe (nominal)	3-114

Exhibit 3-5
Completed CCTDP Coal Processing for Clean Fuels Technology Projects

Project	Process	Size	Page
Commercial-Scale Demonstration of the Liquid Phase Methanol (LPMEOH™) Process	Liquid phase process for methanol production from coal-derived syngas	80,000 gal/day	3-120
Development of the Coal Quality Expert™	Coal Quality Expert™ computer software	Tested at 250–880 MWe	3-124
ENCOAL® Mild Coal Gasification Project	Liquids-from-coal (LFC®) mild gasification to produce solid and liquid fuels	1,000 tons/day*	3-128
		*Operated at 500 tons/day	

Exhibit 3-6
Completed CCTDP Industrial Applications Technology Projects

Project	Process	Size	Page
Blast Furnace Granular-Coal Injection System Demonstration Project	Blast furnace granular-coal injection for reduction of coke use	7,000 net tons/day of hot metal/furnace	3-134
Advanced Cyclone Combustor with Internal Sulfur, Nitrogen, and Ash Control	Advanced slagging combustor with staged combustion and sorbent injection	23x10 ⁶ Btu/hr	3-138
Cement Kiln Flue Gas Recovery Scrubber	Cement kiln dust used to capture SO ₂ ; dust converted to feedstock; and fertilizer and distilled water produced	1,450 tons/day of cement	3-142
Pulse Combustor Design Qualification Test	Advanced combustion using Manufacturing and Technology Conversion International's pulse combustor/gasifier	30x10 ⁶ Btu/hr	3-146

Completed Project Fact Sheets

An index to the completed project fact sheets by application category is provided in Exhibit 3-7. An index by participant is provided in Exhibit 3-2. Projects are listed alphabetically by participant. In addition, Exhibit 3-1 indicates the solicitation under which the project was selected; its status as of May 31, 2003; and the page number for each fact sheet. Exhibit 3-2 lists the projects alphabetically by participant and provides project location and page numbers. A key to interpreting the milestone charts was provided in Exhibit 3-9.

Exhibit 3-7
Completed CCTDP Project Fact Sheets by Application Category

Project	Participant	Solicitation/Status	Page
Environmental Control Devices			
SO₂ Control Technologies			
10-MWe Demonstration of Gas Suspension Absorption	AirPol, Inc.	CCTDP-III/completed 6/95	3-12
Confined Zone Dispersion Flue Gas Desulfurization Demonstration	Bechtel Corporation	CCTDP-III/completed 6/94	3-16
LIFAC Sorbent Injection Desulfurization Demonstration Project	LIFAC–North America	CCTDP-III/completed 4/98	3-20
Advanced Flue Gas Desulfurization Demonstration Project	Pure Air on the Lake, L.P.	CCTDP-II/completed 6/96	3-24
Demonstration of Innovative Applications of Technology for the CT-121 FGD Process	Southern Company Services, Inc.	CCTDP-II/completed 10/99	3-28
NO_x Control Technologies			
Demonstration of Advanced Combustion Techniques for a Wall-Fired Boiler	Southern Company Services, Inc.	CCTDP-II/completed 4/03	3-34
Demonstration of Coal Reburning for Cyclone Boiler NO _x Control	The Babcock & Wilcox Company	CCTDP-II/completed 3/94	3-38
Full-Scale Demonstration of Low-NO _x Cell Burner Retrofit	The Babcock & Wilcox Company	CCTDP-III/completed 12/95	3-42
Evaluation of Gas Reburning and Low-NO _x Burners on a Wall-Fired Boiler	Energy and Environmental Research Corporation	CCTDP-III/completed 10/98	3-46
Micronized Coal Reburning Demonstration for NO _x Control	New York State Electric & Gas Corporation	CCTDP-IV/completed 12/99	3-50
Demonstration of Selective Catalytic Reduction Technology for the Control of NO _x Emissions from High-Sulfur, Coal-Fired Boilers	Southern Company Services, Inc.	CCTDP-II/completed 11/96	3-54
180-MWe Demonstration of Advanced Tangentially Fired Combustion Techniques for the Reduction of NO _x Emissions from Coal-Fired Boilers	Southern Company Services, Inc.	CCTDP-II/completed 6/94	3-58
Combined SO₂/NO_x Control Technologies			
SNOX™ Flue Gas Cleaning Demonstration Project	ABB Environmental Systems	CCTDP-II/completed 7/96	3-64
LIMB Demonstration Project Extension and Coolside Demonstration	The Babcock & Wilcox Company	CCTDP-I/completed 11/92	3-68
SO _x -NO _x -Rox Box™ Flue Gas Cleanup Demonstration Project	The Babcock & Wilcox Company	CCTDP-II/completed 9/95	3-72
Enhancing the Use of Coals by Gas Reburning and Sorbent Injection	Energy and Environmental Research Corporation	CCTDP-I/completed 9/98	3-76
Milliken Clean Coal Technology Demonstration Project	New York State Electric & Gas Corporation	CCTDP-IV/completed 10/99	3-80
Integrated Dry NO _x /SO ₂ Emissions Control System	Public Service Company of Colorado	CCTDP-III/completed 9/99	3-84

Exhibit 3-7 (continued)
Completed CCTDP Project Fact Sheets by Application Category

Project	Participant	Solicitation/Status	Page
Advanced Electric Power Generation			
Fluidized-Bed Combustion			
Tidd PFBC Demonstration Project	The Ohio Power Company	CCTDP-I/completed 12/95	3-90
Nucla CFB Demonstration Project	Tri-State Generation and Transmission Association, Inc.	CCTDP-I/completed 4/92	3-94
Integrated Gasification Combined-Cycle			
Piñon Pine IGCC Power Project	Sierra Pacific Power Company	CCTDP-IV/completed 1/01	3-100
Tampa Electric Integrated Gasification Combined-Cycle Project	Tampa Electric Company	CCTDP-III/completed 12/03	3-104
Wabash River Coal Gasification Repowering Project	Wabash River Coal Gasification Repowering Project Joint Venture	CCTDP-IV/completed 9/00	3-108
Advanced Combustion/Heat Engines			
Healy Clean Coal Project	Alaska Industrial Development and Export Authority	CCTDP-III/completed 4/01	3-114
Coal Processing for Clean Fuels			
Commercial-Scale Demonstration of the Liquid Phase Methanol (LPMEOH™) Process	Air Products Liquid Phase Conversion Company, L.P.	CCTDP-III/completed 6/03	3-120
Development of the Coal Quality Expert™	ABB Combustion Engineering, Inc. and CQ Inc.	CCTDP-I/completed 6/98	3-124
ENCOAL® Mild Coal Gasification Project	ENCOAL Corporation	CCTDP-III/completed 12/97	3-128
Industrial Applications			
Blast Furnace Granular-Coal Injection System Demonstration Project	Bethlehem Steel Corporation	CCTDP-III/completed 10/99	3-134
Advanced Cyclone Combustor with Internal Sulfur, Nitrogen, and Ash Control	Coal Tech Corporation	CCTDP-I/completed 9/91	3-138
Cement Kiln Flue Gas Recovery Scrubber	Passamaquoddy Tribe	CCTDP-II/completed 2/94	3-142
Pulse Combustor Design Qualification Test	ThermoChem, Inc.	CCTDP-IV/completed 3/02	3-146

Exhibit 3-8
Completed CCTDP Project Fact Sheets by Participant

Participant	Project	Location	Page
ABB Combustion Engineering, Inc. and CQ Inc.	Development of the Coal Quality Expert™	Homer City, PA	3-124
ABB Environmental Systems	SNOX™ Flue Gas Cleaning Demonstration Project	Niles, OH	3-64
Air Products Liquid Phase Conversion Company, L.P.	Commercial-Scale Demonstration of the Liquid-Phase Methanol (LPMEOH™) Process	Kingsport, TN	3-120
AirPol, Inc.	10-MWe Demonstration of Gas Suspension Absorption	West Paducah, KY	3-12
Alaska Industrial Development and Export Authority	Healy Clean Coal Project	Healy, AK	3-114
Babcock & Wilcox Company, The	Demonstration of Coal Reburning for Cyclone Boiler NO _x Control	Cassville, WI	3-38
Babcock & Wilcox Company, The	Full-Scale Demonstration of Low-NO _x Cell Burner Retrofit	Aberdeen, OH	3-42
Babcock & Wilcox Company, The	LIMB Demonstration Project Extension and Coolside Demonstration	Loraine, OH	3-68
Babcock & Wilcox Company, The	SO _x -NO _x -Rox Box™ Flue Gas Cleanup Demonstration Project	Dilles Bottom, OH	3-72
Bechtel Corporation	Confined Zone Dispersion Flue Gas Desulfurization Demonstration	Seward, PA	3-16
Bethlehem Steel Corporation	Blast Furnace Granular-Coal Injection System Demonstration Project	Burns Harbor, IN	3-134
Coal Tech Corporation	Advanced Cyclone Combustor with Internal Sulfur, Nitrogen, and Ash Control	Williamsport, PA	3-138
CQ Inc. (see ABB Combustion Engineering and CQ Inc.)			
ENCOAL Corporation	ENCOAL® Mild Coal Gasification Project	Gillette, WY	3-128
Energy and Environmental Research Corporation	Enhancing the Use of Coals by Gas Reburning and Sorbent Injection	Hennepin, IL Springfield, IL	3-76
Energy and Environmental Research Corporation	Evaluation of Gas Reburning and Low-NO _x Burners on a Wall-Fired Boiler	Denver, CO	3-46
LIFAC–North America	LIFAC Sorbent Injection Desulfurization Demonstration Project	Richmond, IN	3-20
New York State Electric & Gas Corporation	Micronized Coal Reburning Demonstration for NO _x Control	Lansing, NY Rochester, NY	3-50
New York State Electric & Gas Corporation	Milliken Clean Coal Technology Demonstration Project	Lansing, NY	3-80
Ohio Power Company, The	Tidd PFBC Demonstration Project	Brilliant, OH	3-90
Passamaquoddy Tribe	Cement Kiln Flue Gas Recovery Scrubber	Thomaston, ME	3-142
Public Service Company of Colorado	Integrated Dry NO _x /SO ₂ Emissions Control System	Nucla, CO	3-84
Pure Air on the Lake, L.P.	Advanced Flue Gas Desulfurization Demonstration Project	Chesterton, IN	3-24
Sierra Pacific Power Company	Piñon Pine IGCC Power Project	Reno, NV	3-100
Southern Company Services, Inc.	Demonstration of Advanced Combustion Techniques for a Wall-Fired Boiler	Coosa, GA	3-34

Exhibit 3-8 (continued)
Completed CCTDP Project Fact Sheets by Participant

Participant	Project	Location	Page
Southern Company Services, Inc.	Demonstration of Innovative Applications of Technology for the CT-121 FGD Process	Newnan, GA	3-28
Southern Company Services, Inc.	Demonstration of Selective Catalytic Reduction Technology for the Control of NO _x Emissions from High-Sulfur, Coal-Fired Boilers	Pensacola, FL	3-54
Southern Company Services, Inc.	180-MWe Demonstration of Advanced Tangentially Fired Combustion Techniques for the Reduction of NO _x Emissions from Coal-Fired Boilers	Lynn Haven, FL	3-58
Tampa Electric Company	Tampa Electric Integrated Gasification Combined-Cycle Project	Mulberry, FL	3-104
ThermoChem, Inc.	Pulse Combustor Design Qualification Test	Baltimore, MD	3-146
Tri-State Generation and Transmission Association, Inc.	Nucla CFB Demonstration Project	Nucla, CO	3-94
Wabash River Coal Gasification Repowering Project Joint Venture	Wabash River Coal Gasification Repowering Project	West Terre Haute, IN	3-108

Exhibit 3-9
Key to Milestone Charts in Project Fact Sheets

Each fact sheet contains a bar chart that highlights major milestones—past and planned. The bar chart shows a project’s duration and indicates the time period for three general categories of project activities—preaward, design and construction, and operation and reporting. The key provided below explains what is included in each of these categories.

 **Preaward**

Includes preaward briefings, negotiations, and other activities conducted during the period between DOE’s selection of the project and award of the cooperative agreement.

 **Design and Construction**

Includes the NEPA process, permitting, design, procurement, construction, preoperational testing, and other activities conducted prior to the beginning of operation of the demonstration.

MTF Memo-to-file

CX Categorical exclusion

EA Environmental assessment

EIS Environmental impact statement

 **Operation and Reporting**

Begins with startup and includes operational testing, data collection, analysis, evaluation, reporting, and other activities to complete the demonstration project.

Environmental Control Devices

SO₂ Control Technologies

10-MWe Demonstration of Gas Suspension Absorption

Project completed

Participant

AirPol, Inc.

Additional Team Members

FLS miljo, Inc. (FLS)—technology owner

Tennessee Valley Authority—cofunder and site owner

Location

West Paducah, McCracken County, KY

Technology

FLS' Gas Suspension Absorption (GSA) system for flue gas desulfurization (FGD)

Plant Capacity/Production

10-MWe equivalent slipstream of flue gas from a 175-MWe wall-fired boiler

Coal

Western Kentucky bituminous: Peabody Martwick, 3.05% sulfur; Emerald Energy, 2.61% sulfur; Andalax, 3.06% sulfur; and Warrior Basin, 3.5% sulfur (used intermittently)

Project Funding

Total	\$7,717,189	100%
DOE	2,315,259	30
Participant	5,401,930	70

Project Objective

To demonstrate the applicability of Gas Suspension Absorption as an economic option for achieving Phase II CAAA SO₂ compliance in pulverized coal-fired boilers using high-sulfur coal.

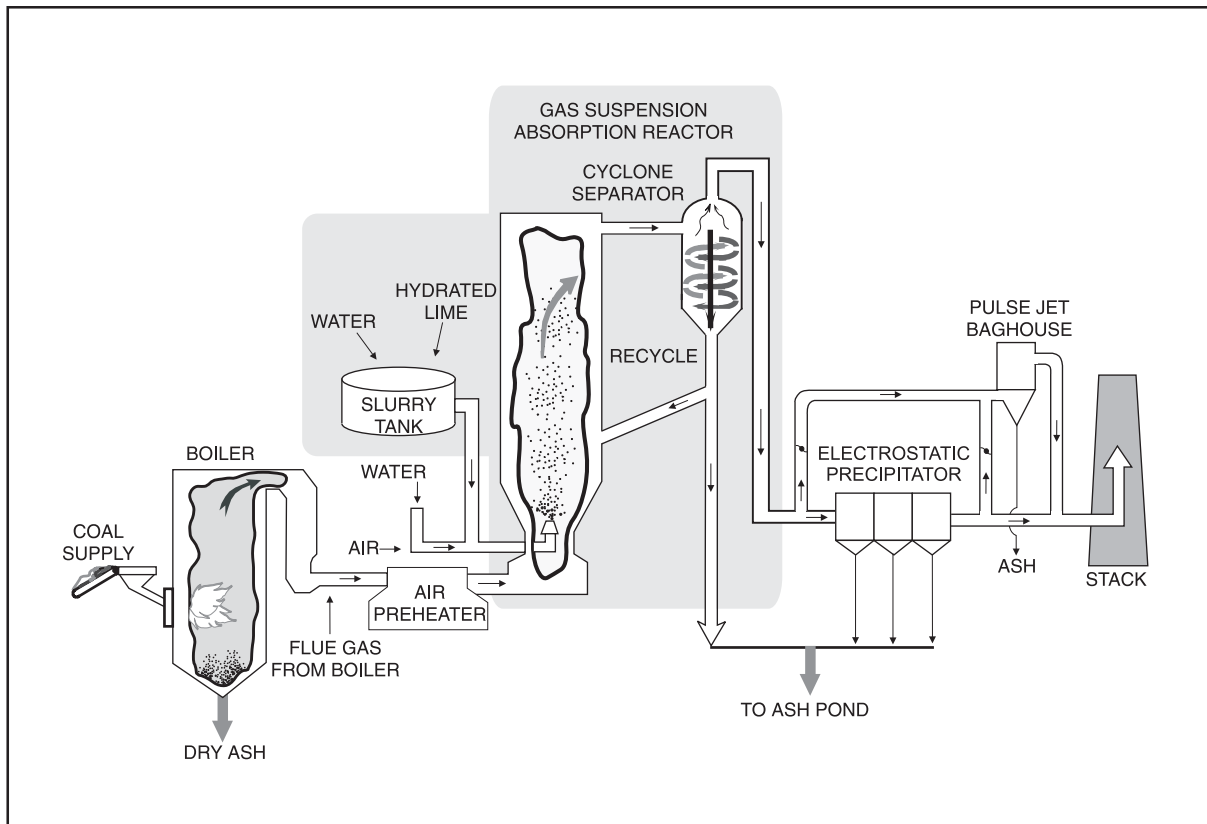

Technology/Project Description

The GSA system consists of a vertical reactor in which flue gas comes into contact with suspended solids consisting of lime, reaction products, and fly ash. About 99% of the solids are recycled to the reactor via a cyclone while the exit gas stream passes through an electrostatic precipitator (ESP) or pulse jet baghouse (PJBH) before being released to the atmosphere. The lime slurry, prepared from hydrated lime, is injected through a spray nozzle at the bottom of the reactor. The volume of lime slurry is regulated with a variable-speed pump controlled by the measurement of the acid content in the inlet and outlet gas streams. The dilution water added to the lime slurry is controlled by on-line measurements of the flue gas exit temperature.

A test program was structured to (1) optimize design of the GSA reactor for reduction of SO₂ emissions from boilers using high-sulfur coal, and (2) evaluate the environmental control capability, economic potential, and mechanical performance of GSA. A statistically designed parametric (factorial) test plan was developed involving six variables. Beyond evaluation of the basic GSA unit to control SO₂, air toxics control tests were conducted, and the effectiveness of GSA/ESP and GSA/PJBH combinations to control both SO₂ and particulates was tested. Factorial tests were followed by continuous runs to verify consistency of performance over time.

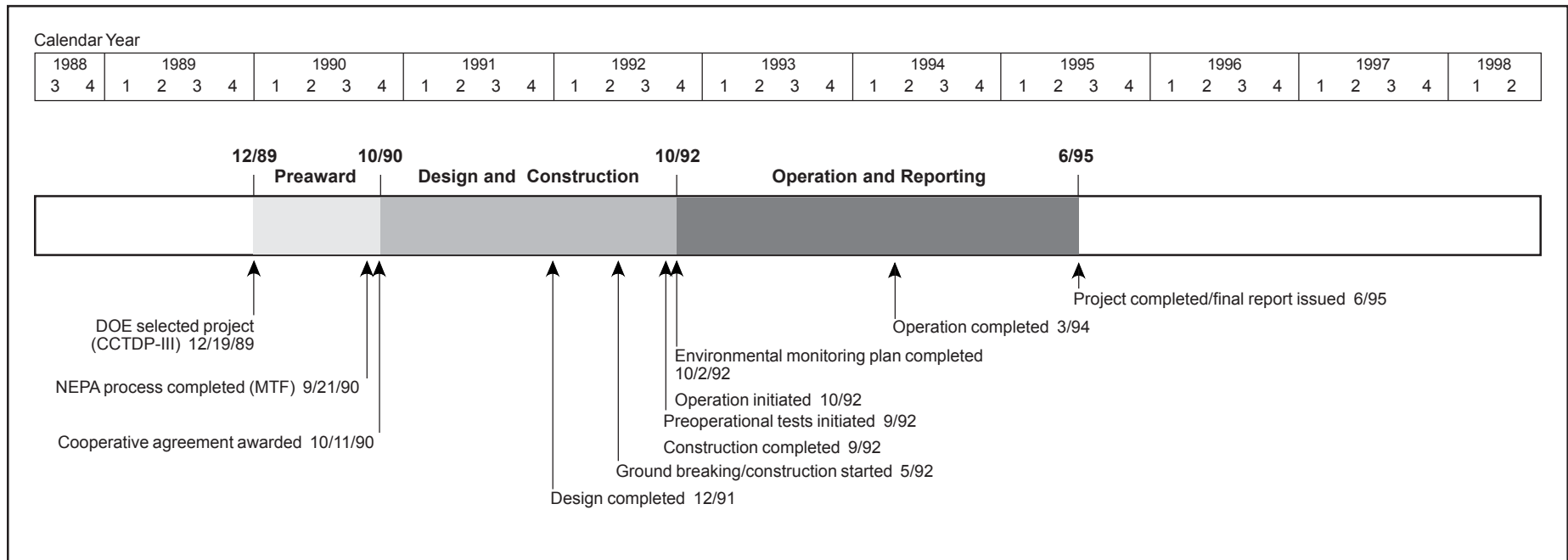

Results Summary

Environmental

- Ca/S molar ratio had the greatest effect on SO₂ removal, with approach-to-saturation temperature next, followed closely by chloride content.
- GSA/ESP achieved
 - 90% sulfur capture at a Ca/S molar ratio of 1.3 with 8 °F approach-to-saturation and 0.02–0.04% chloride,
 - 90% sulfur capture at a Ca/S molar ratio of 1.4 with 18 °F approach-to-saturation and 0.12% chloride, and
 - 99.9+% average particulate removal efficiency.
- GSA/PJBH achieved
 - 96% sulfur capture at a Ca/S molar ratio of 1.4 with 18 °F approach-to-saturation and 0.12% chloride,
 - 3–5% increase in SO₂ reduction relative to GSA/ESP, and
 - 99.99+% average particulate removal efficiency.

- GSA/ESP and GSA/PJBH removed 98% of the hydrogen chloride (HCl), 96% of the hydrogen fluoride (HF), and 99% or more of most trace metals, except cadmium, antimony, mercury, and selenium. (GSA/PJBH removed 99+% of the selenium.)
- The solid by-product was usable as low-grade cement.

Operational

- GSA/ESP lime utilization averaged 66.1% and GSA/PJBH averaged 70.5%.
- The reactor achieved the same performance as a conventional spray dryer, but at one-quarter to one-third the size.
- GSA generated lower particulate loading than a conventional spray dryer, enabling compliance with a lower ESP efficiency.
- Special steels were not required in construction, and only a single spray nozzle is needed.
- High availability and reliability similar to other commercial applications were demonstrated.

Economic

- The capital cost for the GSA system is \$149/kW (1990 constant dollars) with a spare module and \$126/kW without a spare module, based on a 300-MWe plant using 2.6 percent sulfur coal.
- Levelized costs over a 15-year period are estimated at 10.91 mills/kWh (1990 constant dollars) with a spare module and 6.8 mills/kWh without a spare module.

Project Summary

The GSA has a capability of suspending a high concentration of solids, effectively drying the solids, and recirculating the solids at a high rate with precise control. This results in SO₂ control comparable to that of wet scrubbers and high lime utilization. The high concentration of solids provides the sorbent/SO₂ contact area. The drying enables low approach-to-saturation temperature and chloride usage. The rapid, precise, integral recycle system sustains the high solids concentration. The high lime utilization mitigates the largest operating cost (lime) and further reduces costs by reducing the amount of by-product generated. The GSA is distinguished from the average spray dryer by its modest size, simple means of introducing reagent to the reactor, direct means of recirculating unused lime, and low reagent consumption. Also, injected slurry coats recycled solids, not the walls, avoiding corrosion and enabling use of carbon steel in fabrication.

Environmental Performance

Exhibit 3-10 lists the six variables used in the factorial tests and the levels at which they were applied. Inlet flue gas temperature was held constant at 320 °F. Factorial testing showed that lime stoichiometry had the greatest effect on SO₂ removal. Approach-to-saturation temperature was the next most important factor, followed closely by chloride levels. Although an approach-to-saturation temperature of 8 °F was achieved without plugging the system, the test was conducted at a very low chloride level (0.04%). Because water evaporation rates decrease as chloride levels increase, an 18 °F approach-to-saturation temperature was chosen for the higher 0.12% coal chloride level. Exhibit 3-11 summarizes key results from factorial testing.

A 28-day continuous run to evaluate the GSA/ESP configuration was made with bituminous coals averaging 2.7% sulfur, 0.12% chloride levels, and 18 °F approach-to-saturation temperature. A subsequent 14-day continuous run to evaluate the GSA/PJBH configuration was performed under the same conditions as those of the 28-day run, except for adjustments in fly ash injection rate from 1.5–1.0 gr/ft³ (actual).

The 28-day run on the GSA/ESP system showed that the overall SO₂ removal efficiency averaged slightly more than 90%, very close to the set point of 91%, at an average Ca/S molar ratio of 1.40–1.45 (moles Ca(OH)₂/mole inlet SO₂). The system was able to adjust rapidly to the surge in inlet SO₂ caused by switching to 3.5% sulfur Warrior Basin coal for a week. Lime utilization averaged 66.1%. The particu-

late removal efficiency averaged 99.9+% and emission rates were maintained below 0.015 lb/10⁶ Btu. The 14-day run on the GSA/PJBH system showed that the SO₂ removal efficiency averaged more than 96% at an average Ca/S molar ratio of 1.34–1.43 (moles Ca(OH)₂/mole inlet SO₂). Lime utilization averaged 70.5%. The particulate removal efficiency averaged 99.99+% and emission rates ranged from 0.001–0.003 lb/10⁶ Btu.

All air toxics tests were conducted with 2.7% sulfur, low-chloride coal with a 12 °F approach-to-saturation temperature and a high fly ash loading of 2.0 gr/ft³ (actual). The GSA/ESP arrangement indicated average removal efficiencies of greater than 99% for arsenic, barium, chromium, lead, and vanadium; somewhat less for manganese; and less than 99% for antimony, cadmium, mercury, and selenium. The GSA/PJBH configuration showed 99+% removal efficiencies for arsenic, barium, chromium, lead, manganese, selenium, and vanadium; with cadmium removal much lower and mercury removal lower than that of the GSA/ESP system. The removal of HCl and HF was dependent upon the utilization of lime slurry and was relatively independent of particulate control configuration. Removal efficiencies were greater than 98% for HCl and 96% for HF.

Operational Performance

Because the GSA system has suspended recycle solids to provide a contact area for SO₂ capture, multiple high-pressure atomizer nozzles or high-speed rotary nozzles are not required to achieve uniform, fine droplet size. Also, recycle of solids is direct and avoids recycling material in the feed slurry, which would necessitate expensive abrasion-resistant materials in the atomizer(s).

The high heat and mass transfer characteristics of the GSA enable the GSA system to be significantly smaller than a conventional spray dryer for the same capacity—one-quarter to one-third the size. This makes retrofit feasible for space-confined plants and reduces installation cost. The GSA system slurry is sprayed on the recycled solids, not the reactor walls, avoiding direct wall contact and the need for corrosion-resistant alloy steels. Furthermore, the high concentration of rapidly moving solids scours the reactor walls and mitigates scaling. The GSA system generates a significantly lower dust loading than a

Exhibit 3-10 Variables and Levels Used in GSA Factorial Testing

Variable	Level
Approach-to-saturation temperature (°F)	8*, 18, and 28
Ca/S (moles Ca(OH) ₂ /mole inlet SO ₂)	1.00 and 1.30
Fly ash loading (gr/ft ³ , actual)	0.50 and 2.0
Coal chloride level (%)	0.04 and 0.12
Flue gas flow rate (10 ³ scfm)	14 and 20
Recycle screw speed (rpm)	30 and 45

*8 °F was only run at the low coal chloride level.

Exhibit 3-11 GSA Factorial Testing Results

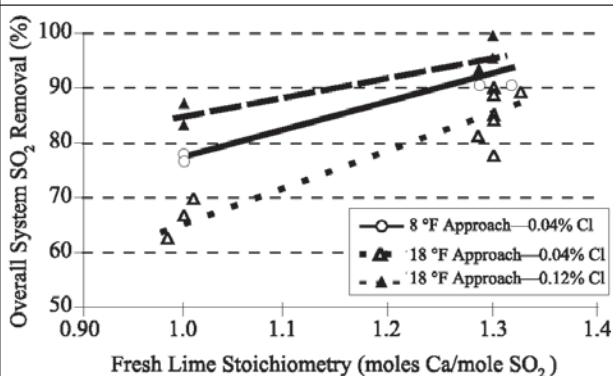

Note: All tests were conducted at a 320 °F inlet flue gas temperature.

conventional spray dryer, 2–5 gr/ft³ for GSA versus 6–10 gr/ft³ for a spray dryer, thereby easing the burden on particulate controls. The GSA system produces a solid by-product containing very low moisture. This material contains both fly ash and unreacted lime. With the addition of water, the by-product undergoes a pozzuolanic reaction, essentially providing the characteristics of a low-grade cement.

Economic Performance

Using EPRI costing methods, which have been applied to 30 to 35 other FGD processes, economics were estimated for a moderately difficult retrofit of a 300-MWe boiler burning 2.6% sulfur coal. The design SO₂ removal efficiency was 90% at a lime feed rate equivalent to 1.30 moles of Ca per mole of inlet SO₂. Lime was assumed to be 2.8 times the cost of limestone. It was estimated that the capital cost was \$149/kW (1990\$) with three units at 50% capacity, and the levelized cost (15-year constant 1990\$) was 10.35 mills/kWh with three units at 50% capacity. With no spare capacity, the capital cost was estimated at \$126/kW and the levelized cost was estimated at 6.8 mills/kWh.

As shown in Exhibit 3-12, a cost comparison for a wet limestone scrubber with forced oxidation (WLFO) scrubber showed the capital and levelized costs to be \$216/kW and 13.04 mills/kWh, respectively. The capital cost listed in EPRI cost tables for a conventional spray dryer at 300 MWe and 2.6% sulfur coal was \$172/kW (1990\$). Also, because the GSA requires less power and has better lime utilization than a spray dryer, the GSA will have a lower operating cost.

Commercial Applications

The low capital cost, moderate operating cost, and high SO₂ capture efficiency make the GSA system particularly attractive as a CAAA compliance option for boilers in the 50- to 250-MWe range. Other major advantages include the modest space requirements comparable to duct injection systems; high availability/reliability owing to design simplicity; and low dust loading, minimizing particulate upgrade costs.



AirPol, Inc. successfully demonstrated the GSA system at TVA's Center for Emissions Research, located at TVA's Shawnee Plant.

Exhibit 3-12 Cost Comparison of GSA and WLFO		
	Capital Cost (1990 \$/kW)	Levelized Cost (mills/kWh)
GSA—3 units at 50% capacity	149	10.35
WLFO	216	13.04

Contacts

Niels H. Kastrup, (281) 539-3416
F.L. Smith Airtech, Inc.
100 Glennborough Drive, Suite 500
Houston, TX 77067-3614
(281) 539-3411 (fax)
nhk@flsairtech.com

Victor K. Der, DOE/HQ, (301) 903-2700
victor.der@hq.doe.gov

Sharon K. Marchant, NETL, (412) 386-6008
marchant@netl.doe.gov

References

10-MWe Demonstration of Gas Suspension Absorption Final Project Performance and Economics Report. Report No. DOE/PC/90542-T9. AirPol, Inc. June 1995. (Available from NTIS as DE95016681.)

10-MW Demonstration of Gas Suspension Absorption Final Public Design Report. Report No. DOE/PC/90542-T10. AirPol, Inc. June 1995. (Available from NTIS as DE960003270.)

SO₂ Removal Using Gas Suspension Absorption Technology. Topical Report No. 4. U.S. Department of Energy and AirPol, Inc. April 1995.

10-MWe Demonstration of the Gas Suspension Absorption Process at TVA's Center for Emissions Research: Final Report. Report No. DOE/PC/90542-T10. Tennessee Valley Authority. March 1995. (Available from NTIS as DE96000327.)

10-MWe Demonstration of Gas Suspension Absorption—Project Performance Summary. U.S. Department of Energy. June 1999.

Confined Zone Dispersion Flue Gas Desulfurization Demonstration

Project completed

Participant

Bechtel Corporation

Additional Team Members

Pennsylvania Electric Company—cofunder and host
 Pennsylvania Energy Development Authority—cofunder
 New York State Electric & Gas Corporation—cofunder
 Rockwell Lime Company—cofunder

Location

Seward, Indiana County, PA (Pennsylvania Electric Company's Seward Station, Unit No. 5)

Technology

Bechtel Corporation's in-duct, confined zone dispersion flue gas desulfurization (CZD/FGD) process

Plant Capacity/Production

73.5 MWe equivalent from a 147 MWe unit

Coal

Pennsylvania bituminous, 1.2–2.5% sulfur

Project Funding

Total*	\$10,411,600	100%
DOE	5,205,800	50
Participant	5,205,800	50

Project Objective

To demonstrate SO₂ removal capabilities of in-duct CZD/FGD technology; specifically, to define the optimum process operating parameters and to determine CZD/FGD's operability, reliability, and cost-effectiveness

*Additional project overrun costs were funded 100% by the participant for a final total project funding of \$12,173,000.

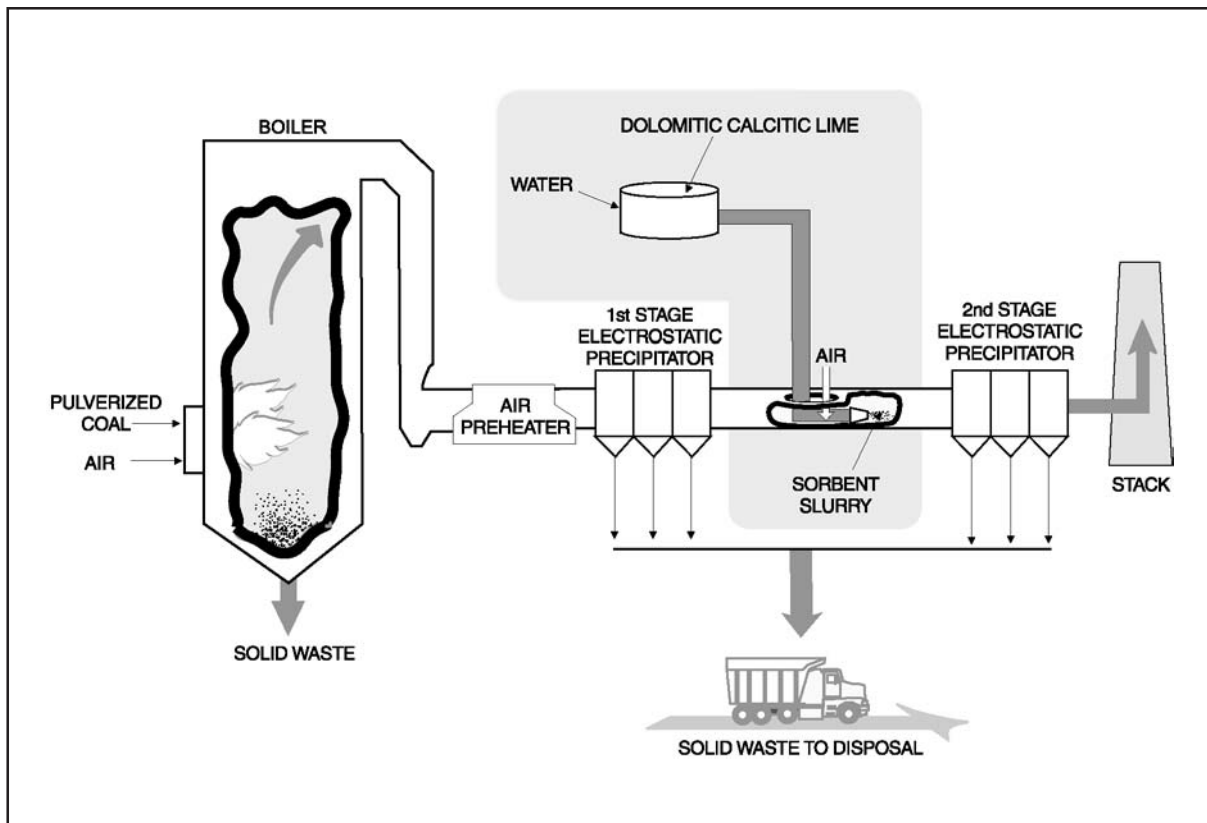

during long-term testing and its impact on downstream operations and emissions.

Technology/Project Description

In Bechtel's CZD/FGD process, a finely atomized slurry of reactive lime is sprayed into the flue gas stream between the boiler air heater and the electrostatic precipitator (ESP). The lime slurry is injected into the center of the duct by spray nozzles designed to produce a cone of fine spray. As the spray moves downstream and expands, the gas within the cone cools and the SO₂ is quickly absorbed on the liquid droplets. The droplets mix with the hot flue gas, and the water evaporates rapidly. Fast drying precludes wet particle buildup in the duct and aids the flue gas in carrying the dry reaction products and the unreacted lime to the ESP.

This project included injection of different types of sorbents (dolomitic and calcitic limes) with several atomizer designs using low- and high-sulfur coals to evaluate the effects on SO₂ removal and ESP performance. The demonstration was conducted at Pennsylvania Electric Company's Seward Station in Seward, Pennsylvania. One-half of the flue gas capacity of the 147-MWe Unit No. 5 was routed through a modified, extended straight section of duct between the first- and second-stage ESPs.

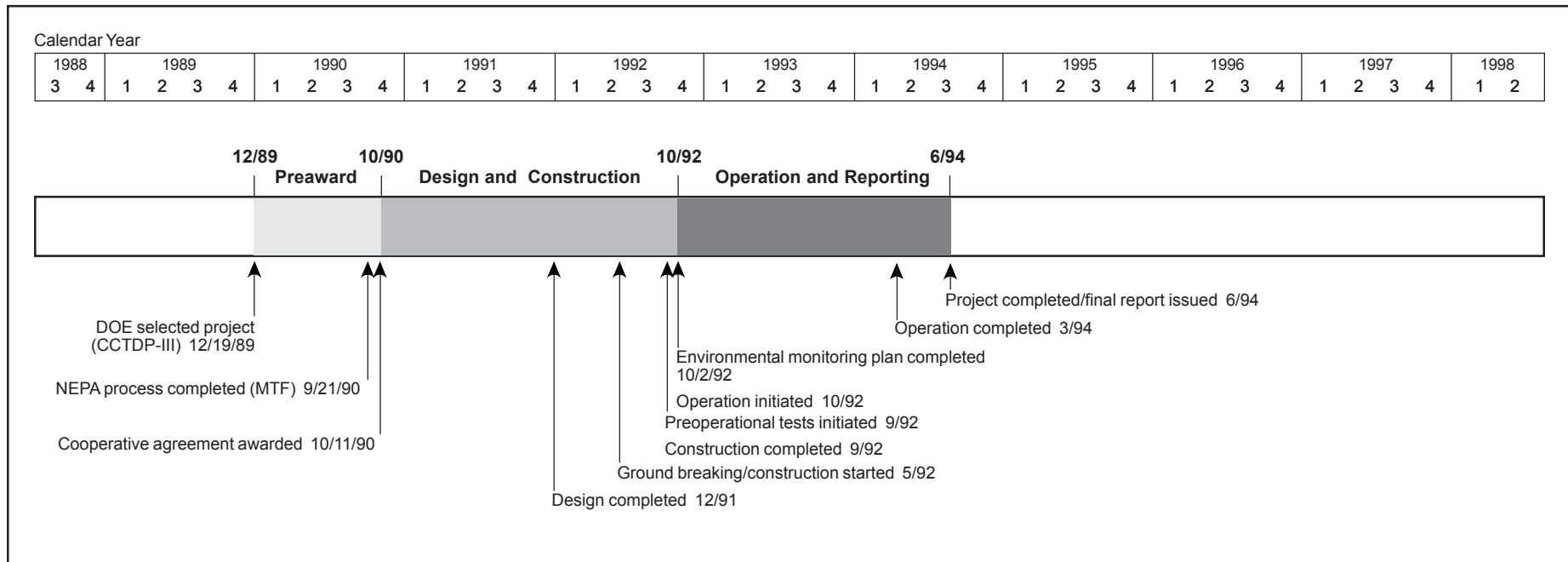

Results Summary

Environmental

- Pressure-hydrated dolomitic lime proved to be a more effective sorbent than either dry hydrated calcitic lime or freshly slaked calcitic lime.
- Sorbent injection rate was the most influential parameter on SO₂ capture. Flue gas temperature was the limiting factor on injection rate. For SO₂ capture efficiency of 50% or more, a flue gas temperature of 300 °F or more was needed.
- Slurry concentration for a given sorbent did not increase SO₂ removal efficiency beyond a certain threshold concentration.
- Testing indicated that SO₂ removal efficiencies of 50% or more were achievable with flue gas temperatures of 300–310 °F (full load), sorbent injection rate of 52–57 gal/min, residence time of 2 seconds, and a pressure-hydrated dolomitic-lime concentration of about 9%.
- For operating conditions at Seward Station, data indicated that for 40–50% SO₂ removal, a 6–8% lime or dolomitic lime slurry concentration, and a stoichiomet-

ric ratio of 2–2.5 resulted in a 40–50% lime utilization rate. That is, 2–2.5 moles of CaO or CaO•MgO were required for every mole of SO₂ removed.

- Assuming 92% lime purity, 1.9–2.4 tons of lime was required for every ton of SO₂ removed.

Operational

- About 100 ft of straight duct was required to assure the 2-second residence time needed for effective CZD/FGD operation.
- At Seward Station, stack opacity was not detrimentally affected by CZD/FGD.
- Availability of CZD/FGD was very good.
- Some CZD/FGD modification will be necessary to assure consistent SO₂ removal and avoid deposition of solids within the ductwork during upsets.

Economic

- Capital cost of a 500-MWe system operating on 4% sulfur coal and achieving 50% SO₂ reduction was estimated at less than \$30/kW and operating cost at \$300/ton of SO₂ removed (1994\$).

Project Summary

The principle of the CZD/FGD is to form a wet zone of slurry droplets in the middle of a duct confined in an envelope of hot gas between the wet zone and the duct walls. The lime slurry reacts with part of the SO_2 in the gas and the reaction products dry to form solid particles. An ESP, downstream from the point of injection, captures the reaction products along with the fly ash entrained in the flue gas.

CZD/FGD did not require a special reactor, simply a modification to the ductwork. Use of the commercially available Type S pressure-hydrated dolomitic lime reduced residence time requirements for CZD/FGD and enhanced sorbent utilization. The increased humidity of CZD/FGD processed flue gas enhanced ESP performance, eliminating the need for upgrades to handle the increased particulate load.

Bechtel began its 18-month, two-part test program for the CZD process in July 1991, with the first 12 months of the test program consisting primarily of parametric testing and the last 6 months consisting of continuous operational testing. During the continuous operational test period, the system was operated under fully automatic control by the host utility boiler operators. The new atomizing nozzles were thoroughly tested both outside and inside the duct prior to system testing.

The SO_2 removal parametric test program, which began in October 1991, was completed in August 1992. Specific objectives were as follows:

- Achieve projected SO_2 removal of 50%;
- Realize SO_2 removal costs of less than \$300/ton; and
- Eliminate negative effects on normal boiler operations without increasing particulate emissions and opacity.

The parametric tests included duct injection of atomized lime slurry made of dry hydrated calcitic lime, freshly slaked calcitic lime, and pressure-hydrated dolomitic lime. All three reagents remove SO_2 from the flue gas but require different feed concentrations of lime slurry for the



Bechtel's demonstration showed that 50% SO_2 removal efficiency was possible using CZD/FGD technology. The extended duct into which lime slurry was injected is in the foreground.

same percentage of SO_2 removed. The most efficient removals and easiest operation were achieved using pressure-hydrated dolomitic lime.

Environmental Performance

Sorbent injection rate proved to be the most influential factor on SO_2 capture. The rate of injection possible was limited by the flue gas temperature. This impacted a portion of the demonstration when air leakage caused flue gas temperature to drop from 300–310 °F to 260–280 °F. At 300–310 °F, injection rates of 52–57 gal/min were possible and SO_2 reductions greater than 50% were achieved. At 260–280 °F, injection rates had to be dropped to 30–40 gal/min, resulting in a 15–30% drop in SO_2 removal efficiency. Slurry concentration for a given sorbent did not increase SO_2 removal efficiency beyond a certain threshold concentration. For example, with pressure-hydrated dolomitic lime, slurry concentrations above 9% did not increase SO_2 capture efficiency.

Parametric tests indicated that SO_2 removals above 50% are possible under the following conditions: flue gas temperature of 300–310 °F; full boiler load of 145–147 MWe; residence time in the duct of 2 seconds; and lime slurry injection rate of 52–57 gal/min.

Operational Performance

The percentage of lime utilization in the CZD/FGD significantly affected the total cost of SO_2 removal. An analysis of the continuous operational data indicated that the percentage of lime utilization was directly dependent on two key factors: (1) percentage of SO_2 removed, and (2) lime slurry feed concentration.

For operating conditions at Seward Station, data indicated that for 40–50% SO_2 removal, a 6–8% lime or dolomitic lime slurry concentration, and a stoichiometric ratio of 2–2.5 resulted in a 40–50% lime utilization rate. That is, 2–2.5 moles of CaO or $\text{CaO}\cdot\text{MgO}$ were required for every mole of SO_2 removed; or assuming 92% lime purity, 1.9–2.4 tons of lime were required for every ton of SO_2 removed. In summary, the demonstration showed the following results:

- A 50% SO_2 removal efficiency with CZD/FGD was possible.
- Drying and SO_2 absorption required a residence time of 2 seconds, which required a long and straight horizontal gas duct of about 100 feet.
- The fully automated system integrated with the power plant operation demonstrated that the CZD/FGD process responded well to automated control operation. However, modifications to the CZD/FGD were required to assure consistent SO_2 removal and avoid deposition of solids within the gas duct during upsets.
- Availability of the system was very good.
- At Seward Station, stack opacity was not detrimentally affected by the CZD/FGD system.

Economic Performance

Estimates show that the CZD/FGD process can achieve costs of \$300/ton of SO_2 removed (1994\$) when operating a 500-MWe unit burning 4% sulfur coal. Based on a 500-MWe plant retrofitted with CZD/FGD for 50% SO_2 removal, the total capital cost is estimated to be less than \$30/kW (1994\$).

Commercial Applications

After the conclusion of the DOE-funded CZD/FGD demonstration project at Seward Station, the CZD/FGD system was modified to improve SO_2 removal during

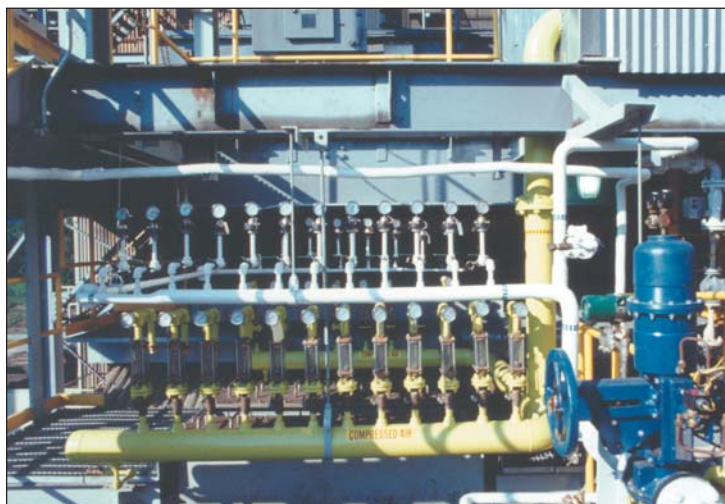

CZD/FGD lime slurry injector control system.

continuous operation while following daily load cycles. Bechtel and the host utility, Pennsylvania Electric Company, continued the CZD/FGD demonstration for an additional year. Results showed that CZD/FGD operation at SO₂ removal rates lower than 50% could be sustained over long periods without significant process problems.

CZD/FGD can be used for retrofitting existing plants and installation in new utility boiler flue gas facilities to remove SO₂ from a wide variety of sulfur-containing coals. A CZD/FGD system can be added to a utility boiler with a capital investment of about \$25–50/kW of installed capacity, or approximately one-fourth the cost of building a conventional wet scrubber. In addition to low capital cost, other advantages include small space requirements, ease of retrofit, low energy requirements, fully automated operation, and production of only nontoxic, disposable waste. The CZD/FGD technology is particularly well suited for retrofitting existing boilers, independent of type, age, or size. The CZD/FGD installation does not require major power station alterations and can be easily and economically integrated into existing power plants.

Contacts

Joseph T. Newman, Project Manager
(415) 768-1014
Bechtel Corporation
P.O. Box 193965
San Francisco, CA 94119-3965
(415) 768-3535 (fax)

Victor K. Der, DOE/HQ, (301) 903-2700
victor.der@hq.doe.gov

Thomas A. Sarkus, NETL, (412) 386-5981
sarkus@netl.doe.gov

References

Confined Zone Dispersion Project: Final Technical Report. Bechtel Corporation. June 1994.

Confined Zone Dispersion Project: Public Design Report. Bechtel Corporation. October 1993.

Comprehensive Report to Congress on the Clean Coal Technology Program: Confined Zone Dispersion Flue Gas Desulfurization Demonstration. Bechtel Corporation. Report No. DOE/FE-0203P. U.S. Department of Energy. September 1990. (Available from NTIS as DE91002564.)

LIFAC Sorbent Injection Desulfurization Demonstration Project

Project completed

Participant

LIFAC–North America (a joint venture partnership between Tampella Power Corporation and ICF Kaiser Engineers, Inc.)

Additional Team Members

ICF Kaiser Engineers, Inc.—cofunder and project manager

Tampella Power Corporation—cofunder

Tampella, Ltd.—technology owner

Richmond Power and Light—cofunder and host utility

Electric Power Research Institute—cofunder

Black Beauty Coal Company—cofunder

State of Indiana—cofunder

Location

Richmond, Wayne County, IN (Richmond Power & Light's Whitewater Valley Station, Unit No. 2)

Technology

LIFAC's sorbent injection process with sulfur capture in a unique, patented vertical activation reactor

Plant Capacity/Production

60 MWe

Coal

Bituminous, 2.0–2.8% sulfur

Project Funding

Total	\$21,393,772	100%
DOE	10,636,864	50
Participants	10,756,908	50

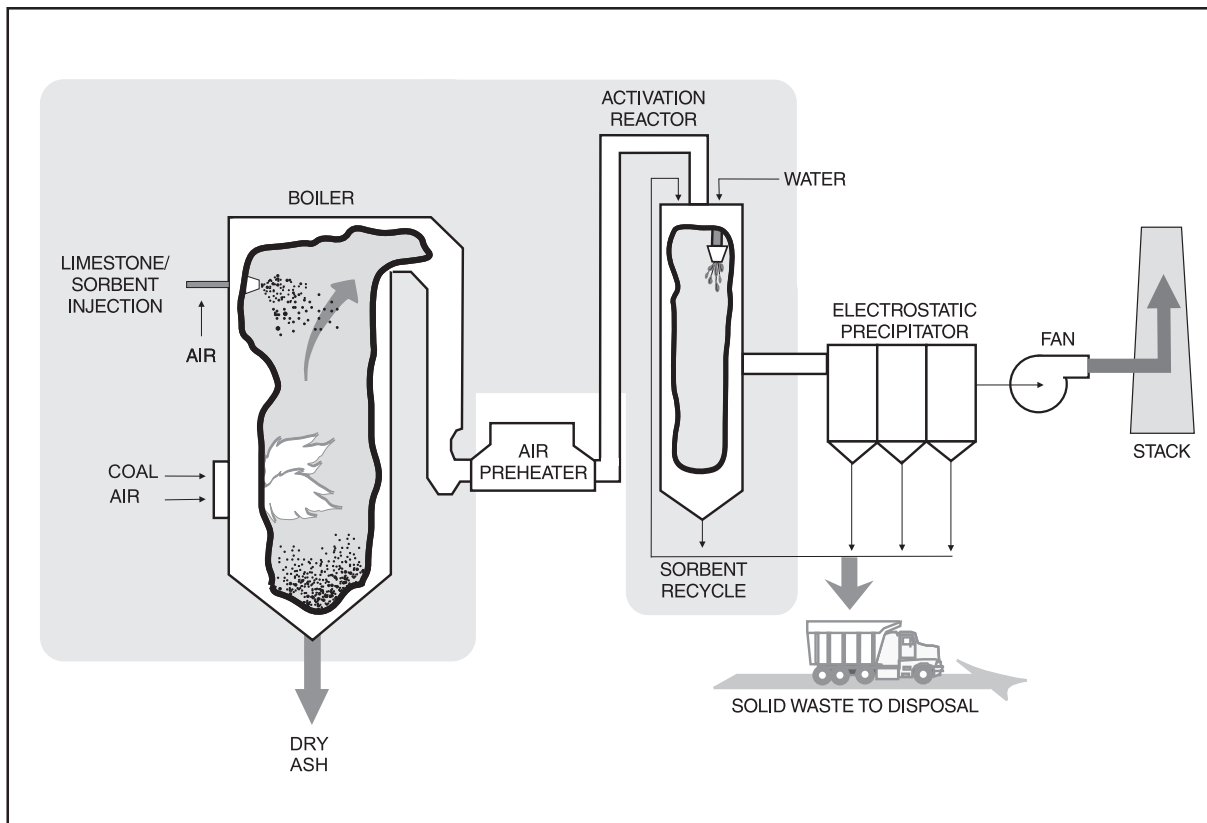

Project Objective

To demonstrate that electric power plants—especially those with space limitations and burning high-sulfur coals—can be retrofitted successfully with the LIFAC limestone injection process to remove 75–85% of the SO₂ from flue gas and produce a dry solid waste product for disposal in a landfill.

Technology/Project Description

Pulverized limestone is pneumatically injected into the upper part of the boiler near the superheater where it absorbs some of the SO₂ in the boiler flue gas. The limestone is calcined into calcium oxide and is available for capture of additional SO₂ downstream in the activation, or humidification, reactor. In the vertical chamber, water sprays initiate a series of chemical reactions leading to SO₂ capture. After leaving the chamber, the sorbent is

easily separated from the flue gas along with the fly ash in the electrostatic precipitator (ESP). The sorbent material from the reactor and electrostatic precipitator are recirculated back through the reactor for increased efficiency. The waste is dry, making it easier to handle than the wet scrubber sludge produced by conventional wet limestone scrubber systems.

The technology enables power plants with space limitations to use high-sulfur midwestern coals, by providing an injection process that removes 75–85% of the SO₂ from flue gas and produces a dry solid waste product suitable for disposal in a landfill.

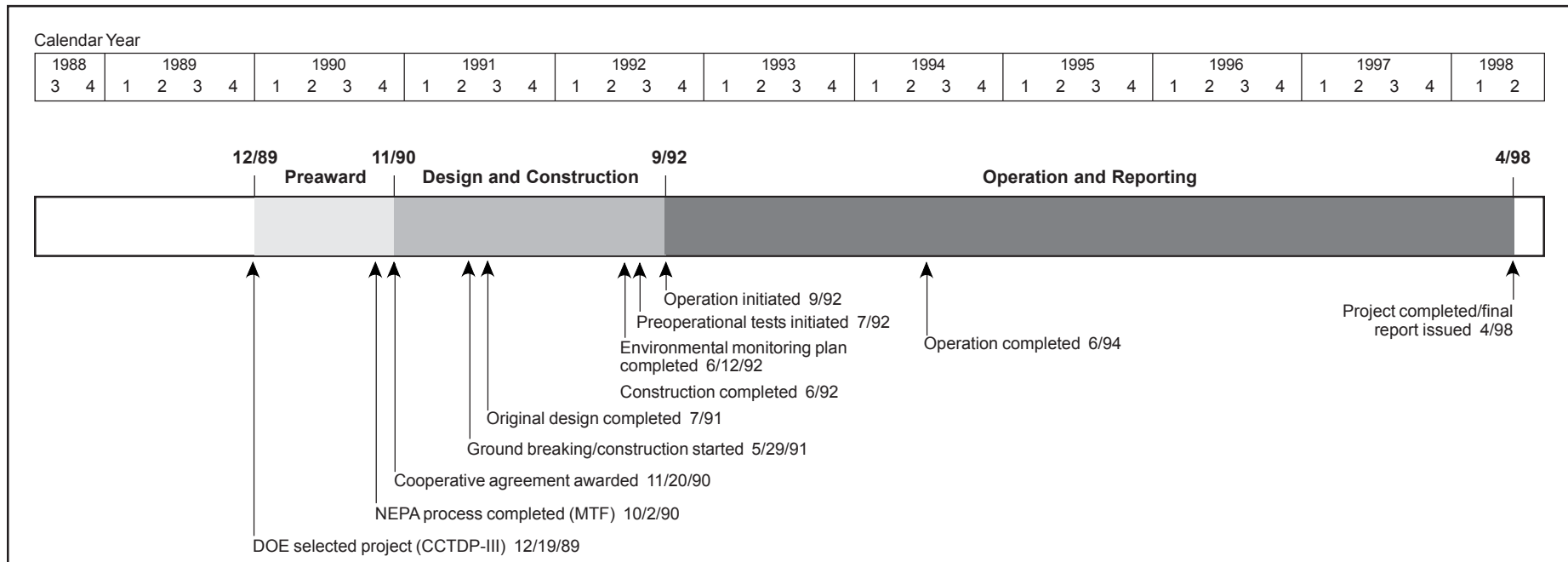

Results Summary

Environmental

- SO₂ removal efficiency was 70% at a calcium-to-sulfur (Ca/S) molar ratio of 2.0, approach-to-saturation temperature of 7–12 °F, and limestone fineness of 80% minus 200 mesh.
- SO₂ removal efficiency was increased an additional 15% by increasing limestone fineness to 80% minus 325 mesh and maintaining a Ca/S molar ratio of 2.0 and 7–12 °F approach-to-saturation temperature.
- The four parameters having the greatest influence on sulfur removal efficiency were limestone fineness, Ca/S molar ratio, approach-to-saturation temperature, and ESP ash recycle rate.
- ESP ash recycle rate was limited in the demonstration system configuration. Increasing the recycle rate and sustaining a 5 °F approach-to-saturation temperature were projected to increase SO₂ removal efficiency to 85% at a Ca/S molar ratio of 2.0 and limestone fineness of 80% minus 325 mesh.

- ESP efficiency and operating levels were essentially unaffected by LIFAC during steady-state operation.
- Fly and bottom ash were dry and readily disposed of at a local landfill. The quantity of additional solid waste can be determined by assuming that approximately 4.3 tons of limestone is required to remove 1.0 ton of SO₂.

Operational

- When operating with fine limestone (80% minus 325 mesh), the sootblowing cycle had to be reduced from 6.0–4.5 hours.
- Automated programmable logic and simple design make the LIFAC system easy to operate in startup, shutdown, or normal duty cycles.
- The amount of bottom ash increased slightly, but there was no negative impact on the ash-handling system.

Economic

- Capital cost (1994\$)—\$66/kW for two LIFAC reactors (300 MWe); \$76/kW for one LIFAC reactor (150 MWe); \$99/kW for one LIFAC reactor (65 MWe).

- Operating cost (1994\$)—\$65/ton of SO₂ removed, assuming 75% SO₂ capture, Ca/S molar ratio of 2.0, limestone composed of 95% CaCO₃, and costing \$15/ton.

Project Summary

The LIFAC technology was designed to enhance the effectiveness of dry sorbent injection systems for SO₂ control and to maintain the desirable aspects of low capital cost and compactness for ease of retrofit. Furthermore, limestone was used as the sorbent (about 1/3 of the cost of lime) and a sorbent recycle system was incorporated to reduce operating costs.

The process evaluation test plan was composed of five distinct phases, each having its own objectives. These tests were:

- Baseline tests characterized the operation of the host boiler and associated subsystems prior to LIFAC operations.
- Parametric tests were designed to evaluate the many possible combinations of LIFAC process parameters and their effect on SO₂ removal.
- Optimization tests were performed after the parametric tests to evaluate the reliability and operability of the LIFAC process over short, continuous operating periods.
- Long-term tests were designed to demonstrate LIFAC's performance under commercial operating conditions.
- Post-LIFAC tests involved repeating the baseline test to identify any changes caused by the LIFAC system.

The coals used during the demonstration varied in sulfur content from 1.4–2.8%. However, most of the testing was conducted with the higher (2.0–2.8%) sulfur coals.

Environmental Performance

During the parametric testing phase, the numerous LIFAC process values and their effects on sulfur removal efficiency were evaluated. The four major parameters having the greatest influence on sulfur removal efficiency were limestone fineness, Ca/S molar ratio, reactor bottom temperature (approach-to-saturation), and ESP ash recycling rate. Total SO₂ capture was about 15% better when injecting fine limestone (80% minus 325 mesh) than it was with coarse limestone (80% minus 200 mesh).

While injecting the fine limestone, the sootblowing frequency had to be increased from 6-hour to 4.5-hour cycles. The coarse-quality limestone did not affect soot-

blowing but was found to be more abrasive on the feed and transport hoses.

Parametric tests indicated that a 70% SO₂ reduction was achievable with a Ca/S molar ratio of 2.0. ESP ash containing unspent sorbent and fly ash was recycled from the ESP hoppers back into the reactor inlet duct work. Ash recycling was found to be essential for efficient SO₂ capture. However, the large quantity of ash removed from the LIFAC reactor bottom and the small size of the ESP hoppers limited the ESP ash recycling rate. As a result, the amount of material recycled from the ESP was approximately 70% less than had been anticipated, but even this low recycling rate was found to affect SO₂ capture. During a brief test, it was found that increasing the recycle rate by 50% resulted in a 5% increase in SO₂ removal efficiency. It was estimated that if the reactor bottom ash is recycled along with ESP ash, while sustaining a reactor temperature of 5 °F above saturation temperature, an SO₂ reduction of 85% could be maintained.

Operational Performance

Optimization testing began in March 1994 and was followed by long-term testing in June 1994. The boiler was operated at an average load of 60 MWe during long-term testing, although it fluctuated according to power demand. The LIFAC process automatically adjusted to boiler load changes. A Ca/S molar ratio of 2.0 was selected to attain SO₂ reductions above 70%. Reactor bottom temperature was about 5 °F higher than optimum to avoid ash buildup on the steam reheaters. Atomized water droplet size was smaller than optimum for the same reason. Other key process parameters held constant during the long-term tests included the degree of humidification, grind size of the high-calcium-content limestone, and recycle of spent sorbent from the ESP.

Long-term testing showed that SO₂ reductions of 70% or more can be maintained under normal boiler operating conditions. Stack opacity was low (about 10%) and ESP efficiency was high (99.2%). The amount of boiler bottom ash increased slightly during testing, but there was no negative impact on the power plant's bottom and fly ash removal system. The solid waste generated was a mixture of fly ash and calcium compounds, and was readily disposed of at a local landfill.



The LIFAC system successfully demonstrated at Whitewater Valley Station Unit No. 2 is being retained by Richmond Power & Light for commercial use with high-sulfur coal. There are 10 full-scale LIFAC units in Canada, China, Finland, Russia, and the United States.

The LIFAC system proved to be highly practical because it has few moving parts and is simple to operate. The process can be easily shut down and restarted. The process is automated by a programmable logic system that regulates process control loops, interlocking, startup, shutdown, and data collection. The entire LIFAC process was easily managed via two personal computers located in the host utility's control room.



The top of the LIFAC reactor is shown being lifted into place. During 2,800 hours of operation, long-term testing showed that SO₂ reductions of 70% or more could be sustained under normal boiler operation.

Economic Performance

The economic evaluation indicated that the capital cost of a LIFAC installation is lower than for either a spray dryer or wet scrubber. Capital costs for LIFAC technology vary, depending on unit size and the quantity of reactors needed:

- \$99/kW for one LIFAC reactor at Whitewater Valley Station (65 MWe) (1994\$),

- \$76/kW for one LIFAC reactor at Shand Station (150 MWe), and
- \$66/kW for two LIFAC reactors at Shand Station (300 MWe).

Crushed limestone accounts for about one-half of LIFAC's operating costs. LIFAC requires 4.3 tons of limestone to remove 1.0 ton of SO₂, assuming 75% SO₂ capture, a Ca/S molar ratio of 2.0, and limestone containing 95% CaCO₃. Assuming limestone costs of \$15/ton, LIFAC's operating cost would be \$65/ton of SO₂ removed.

Commercial Applications

The LIFAC system at Richmond Power & Light is the first to be applied to a power plant using high-sulfur (2.0–2.8%) coal. The LIFAC system is being retained by Richmond Power & Light at Whitewater Valley Station, Unit No. 2.

Contacts

Ilari Ekman, 358-9-348-5-511
 Enprima Engineering, Ltd.
 P.O. Box 61, 01601
 Vantaa, Finland
 ilari.ekman@enprima.com

Victor K. Der, DOE/HQ, (301) 903-2700
 victor.der@hq.doe.gov

Thomas A. Sarkus, NETL, (412) 386-5981
 sarkus@netl.doe.gov

References

LIFAC Sorbent Injection Desulfurization Demonstration Project. Final Report, Vol. II: Project Performance and Economics. LIFAC-North America. February 1998. (Available from NTIS as DE96004421.)

"LIFAC Nearing Marketability." *Clean Coal Today.* Report No. DOE/FE-0215P-21. Spring 1996.

"Commercialization of the LIFAC Sorbent Injection Process in North America." *Third Annual Clean Coal Technology Conference: Technical Papers.* Viiala, J., et al. September 1994.

Comprehensive Report to Congress on the Clean Coal Technology Program: LIFAC Sorbent Injection Desulfurization Demonstration Project. LIFAC-North America. Report No. DOE/FE-0207P. U.S. Department of Energy, October 1990. (Available from NTIS as DE91001077.)

Advanced Flue Gas Desulfurization Demonstration Project

Project completed

Participant

Pure Air on the Lake, L.P. (a project company of Pure Air, which is a general partnership between Air Products and Chemicals, Inc., and Mitsubishi Heavy Industries America, Inc.)

Additional Team Members

Northern Indiana Public Service Company—cofunder and host

Mitsubishi Heavy Industries, Ltd.—process designer
 Stearns-Roger Division of United Engineers and Constructors—facility designer

Air Products and Chemicals, Inc.—constructor and operator

Location

Chesterton, Porter County, IN (Northern Indiana Public Service Company's Bailly Generating Station, Unit Nos. 7 and 8)

Technology

Pure Air's advanced flue gas desulfurization (AFGD) process and PowerChip® agglomeration process

Plant Capacity/Production

528 MWe

Coal

Bituminous, 2.25–4.5% sulfur

Project Funding

Total	\$151,707,898	100%
DOE	63,913,200	42
Participant	87,794,698	58

PowerChip is a registered trademark of Pure Air on the Lake, L.P.

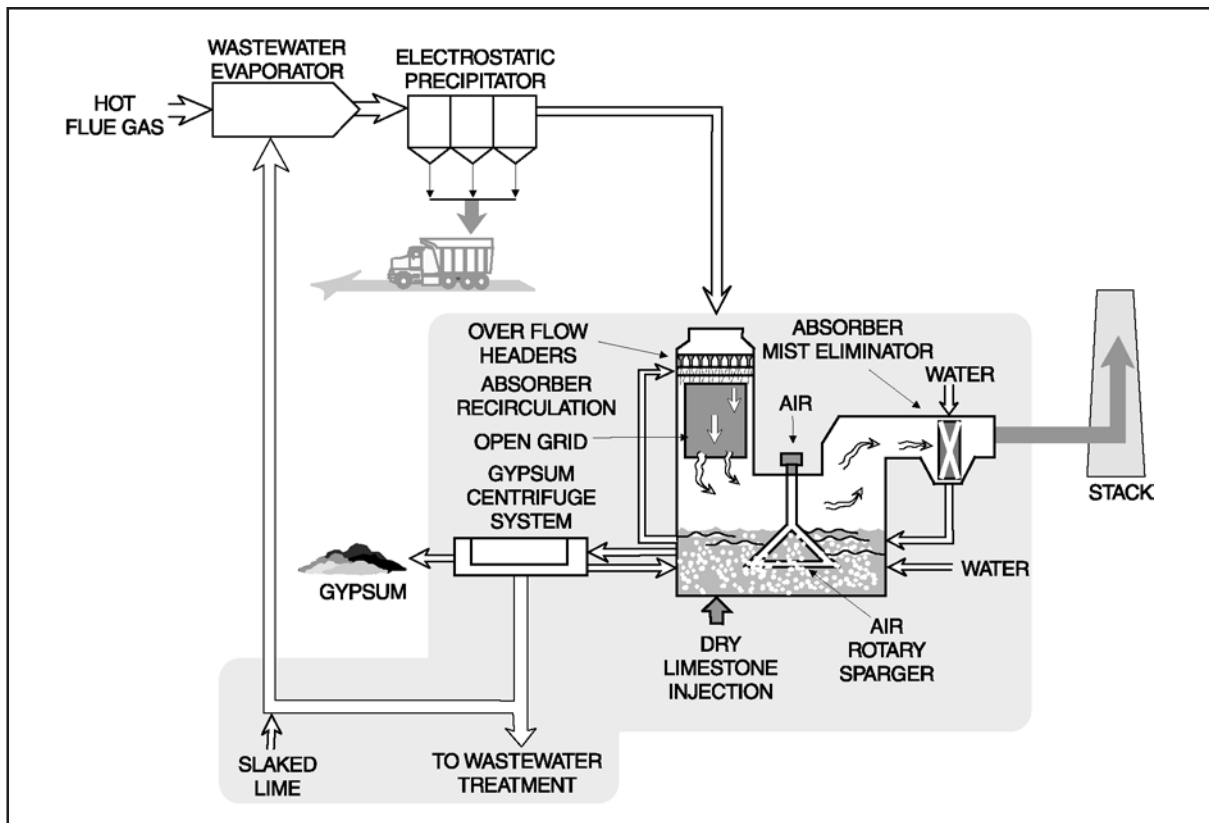

Project Objective

To reduce SO₂ emissions by 95% or more at approximately one-half the cost of conventional scrubbing technology, significantly reduce space requirements, and create no new waste streams.

Technology/Project Description

Pure Air built a single SO₂ absorber for a 528-MWe power plant. Although the largest capacity absorber module of its time in the United States, space requirements were modest because no spare or backup absorber modules were required. The absorber performed three functions in a single vessel: prequenching, absorbing, and oxidation of sludge to gypsum. Additionally, the absorber was of a co-current design, in which the flue gas and scrubbing slurry move in the same direction and at a relatively high velocity compared to that in conventional

counter-current scrubbers. These features all combined to yield a state-of-the-art SO₂ absorber that was more compact and less expensive than contemporary conventional scrubbers.

Other technical features included the injection of pulverized limestone directly into the absorber, a device called an air rotary sparger located within the base of the absorber, and a novel wastewater evaporation system. The air rotary sparger combined the functions of agitation and air distribution into one piece of equipment to facilitate the oxidation of calcium sulfite to gypsum.

Pure Air also demonstrated a unique gypsum agglomeration process, PowerChip®, to significantly enhance handling characteristics of AFGD-derived gypsum.

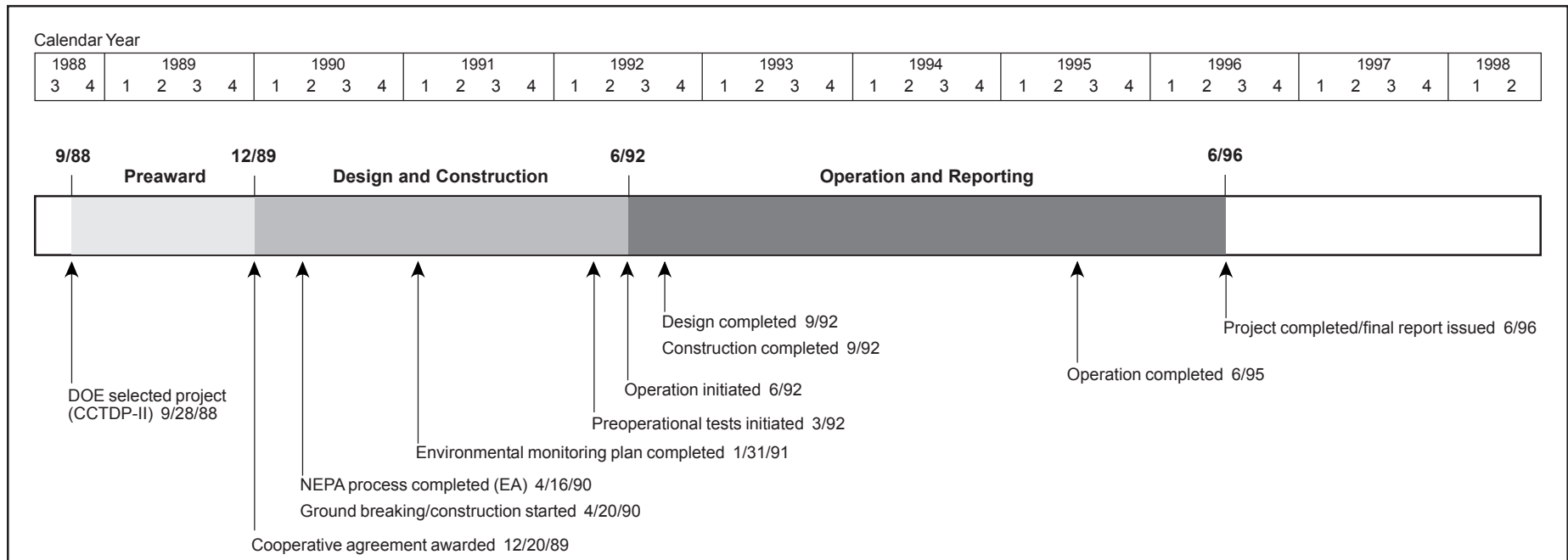

Results Summary

Environmental

- The AFGD design enabled a single 600-MWe absorber module without spares to remove 95% or more SO₂ at availabilities of 99.5% when operating with high-sulfur coals.
- Wallboard-grade gypsum was produced in lieu of solid waste, and all gypsum produced was sold commercially.
- The wastewater evaporation system (WES) mitigated expected increases in wastewater generation associated with gypsum production and showed the potential for achieving zero wastewater discharge (only a partial-capacity WES was installed).
- Air toxics testing established that all acid gases were effectively captured and neutralized by the AFGD. Trace elements largely became constituents of the solids streams (bottom ash, fly ash, and gypsum product). Some boron, selenium, and mercury passed to the stack gas in a vapor state.

Operational

- AFGD use of co-current, high-velocity flow; integration of functions; and a unique air rotary sparger proved to be highly efficient, reliable (to the exclusion of requiring a spare module), and compact. The compactness, combined with no need for a spare module, significantly reduced space requirements.
- The own-and-operate contractual arrangement—Pure Air took on the turnkey, financing, operating, and maintenance risks through performance guarantees—was successful.
- PowerChip® increased the market potential for AFGD-derived gypsum by cost-effectively converting it to a product with the handling characteristics of natural rock gypsum.

Economic

- Capital costs and space requirements for AFGD were about half those of conventional systems.

Project Summary

The project proved that single absorber modules of advanced design could process large volumes of flue gas and provide the required availability and reliability without the usual spare absorber modules. The major performance objectives were met.

Over the three-year demonstration, the AFGD unit accumulated 26,280 hours of operation with an availability of 99.5%. Approximately 237,000 tons of SO₂ were removed, with capture efficiencies of 95% or more, and over 210,000 tons of salable gypsum were produced. The AFGD continues in commercial service, which includes sale of all by-product gypsum to U.S. Gypsum's East Chicago, Indiana wall-board production plant.

Environmental Performance

Testing over the three-year period clearly established that AFGD operating within its design parameters (without additives) could consistently achieve 95% SO₂ reduction or more with 2.25–4.5% sulfur coals. The design range for the calcium-to-sulfur stoichiometric ratio was 1.01–1.07, with the upper value set by gypsum purity requirements (*i.e.*, amount of unreacted reagent allowed in the gypsum). Another key control parameter was the ratio L/G, which is the amount of reagent slurry injected into the absorber grid (L) to the volume of flue gas (G). The design L/G range was 50–128 gal/1,000 ft³. The lower end of the L/G ratio was determined by solids settling rates in the slurry and the requirement for full wetting of the grid packing. The high end of the L/G ratio was determined by where performance leveled out.

Four coals with differing sulfur contents were selected for parametric testing to examine SO₂ removal efficiency as a function of load, sulfur content, stoichiometric ratio, and L/G. Loads tested were 33%, 67%, and 100%. High removal efficiencies, well above 95%, were possible at loads of 33% and 67% with low to moderate stoichiometric ratio and L/G settings, even for 4.5% sulfur coal. Exhibit 3-13 summarizes the results of parametric testing at full load.

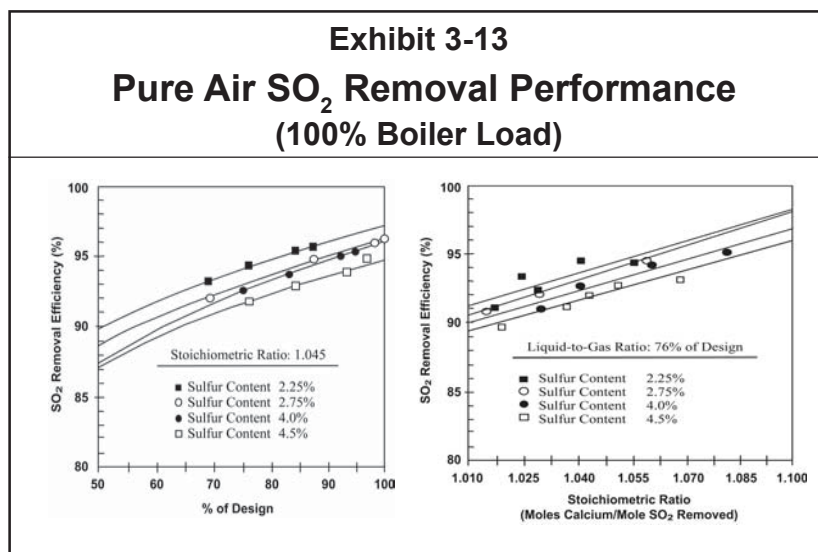

In the AFGD process, chlorides that would have been released to the air are captured, but potentially become a wastewater problem. This was mitigated by the addition of the WES, which takes a portion of the wastewater stream with high chloride and sulfate levels and injects it into the ductwork upstream of the ESP. The hot flue gas evaporates the water and the dissolved solids are captured in the ESP. Problems were experienced early on with the WES nozzles failing to provide adequate atomization and plugging. These problems were resolved by replacing the original single-fluid nozzles with dual-fluid systems employing air as the second fluid.

Commercial-grade gypsum quality (95.6–99.7%) was maintained throughout testing, even at the lower sulfur concentrations where the ratio of fly ash to gypsum increases due to lower sulfate availability. The primary importance of producing a commercial-grade gypsum is avoidance of the environmental and economic consequences of disposal. Marketability of the gypsum is dependent upon whether users are in range of economic transport and whether they can handle the gypsum by-product. For these reasons, PowerChip[®] technology was demonstrated as part of the project. This technology uses a compression mill to convert the highly cohesive AFGD gypsum cake into a flaked product with handling charac-

teristics equivalent to natural rock gypsum. The process avoids use of binders, pre-drying, or pre-calcining normally associated with briquetting, and is 30–55% cheaper at \$2.50–\$4.10/ton.

Air toxics testing established that all acid gases are effectively captured and neutralized by the AFGD. Trace elements largely become constituents of the solids streams (bottom ash, fly ash, gypsum product). Some boron, selenium, and mercury pass to the stack gas in a vapor state.

Operational Performance

Availability over the 3-year operating period averaged 99.5% while maintaining an average SO₂ removal efficiency of 94%. This was attributable to the simple, effective design and an effective operating/maintenance philosophy. Modifications contributed to the

high availability. An example was the implementation of new alloy technology, C-276 alloy over carbon steel clad material, to replace alloy wallpaper construction within the absorber tower wet/dry interface. The use of co-current rather than conventional counter-current flow resulted in lower pressure drops across the absorber and afforded the flexibility to increase gas flow without an abrupt drop in removal efficiency. The AFGD SO₂ capture efficiency with limestone was comparable to that in wet scrubbers using lime, which is far more expensive. The 24-hour power consumption was 5,275 kW, or 61% of expected consumption, and water consumption was 1,560 gal/min, or 52% of expected consumption.

Economic Performance

Exhibit 3-14 summarizes capital and levelized 1995 current dollar cost estimates for nine cases with varying plant capacity and coal sulfur content. A capacity factor of 65% and a sulfur removal efficiency of 90% were assumed. The calculation of levelized cost followed guidelines established in EPRI's *Technical Assessment Guide*TM.

The incremental benefits of the own-and-operate arrangement, by-product utilization, and emission allowances were also evaluated. Exhibit 3-15 depicts the relative

Exhibit 3-14
Estimated Costs for an AFGD System
(1995 Current Dollars)

Cases:	1	2	3	4	5	6	7	8	9
Plant size (MWe)	100	100	100	300	300	300	500	500	500
Coal sulfur content (%)	1.5	3.0	4.5	1.5	3.0	4.5	1.5	3.0	4.5
Capital cost (\$/kW)	193	210	227	111	121	131	86	94	101
Levelized cost (\$/ton SO ₂)									
15-year life	1,518	840	603	720	401	294	536	302	223
20-year life	1,527	846	607	716	399	294	531	300	223
Levelized cost (mills/kWh)									
15-year life	16.39	18.15	19.55	7.78	8.65	9.54	5.79	6.52	7.24
20-year life	16.49	18.28	19.68	7.73	8.62	9.52	5.74	6.48	7.21

costs of a hypothetical 500-MWe generating unit in the Midwest burning 4.3% sulfur coal with a base case conventional FGD system and four incremental cases. The horizontal lines in Exhibit 3-15 show the range of costs for a fuel-switching option. The lower line is the cost of fuel delivered to the hypothetical midwest unit, and the upper line allows for some plant modifications to accommodate the compliance fuel.

Commercial Applications

The AFGD technology is positioned well to compete in the pollution control arena of the 21st century. The AFGD technology has markedly reduced cost and demonstrated the ability to compete with fuel switching under certain circumstances even with a first-generation system. Advances in technology, e.g., in materials and components, should lower costs for AFGD. The own-and-operate business approach has done much to mitigate risk on the part of prospective users. High SO₂ capture efficiency offers the AFGD user the possibility of generating allowances or applying credits to other units within the utility. WES and PowerChip[®] mitigate or eliminate otherwise serious environmental concerns. AFGD effectively deals with hazardous air pollutants.

The project received *Power* magazine's 1993 Powerplant Award and the National Society of Professional Engineers' 1992 Outstanding Engineering Achievement Award.

Contacts

Tim Roth, (610) 481-6257
 Pure Air on the Lake, LP
 c/o Air Products and Chemicals, Inc.
 7201 Hamilton Boulevard
 Allentown, PA 18195-1501
 rothtj@apci.com

Victor K. Der, DOE/HQ, (301) 903-2700
 victor.der@hq.doe.gov

Thomas A. Sarkus, NETL, (412) 386-5981
 sarkus@netl.doe.gov

References

Summary of Air Toxics Emissions Testing at Sixteen Utility Power Plants. Prepared by Burns and Roe Services Corporation for U.S. Department of Energy, Pittsburgh Energy Technology Center. July 1996.

Exhibit 3-15
Flue Gas Desulfurization
Economics

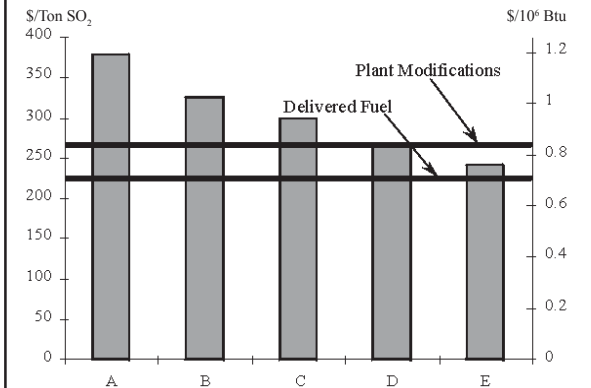

500-MWe plant, 30-yr levelized costs, allowance value of \$300/ton

Incremental cases:

- A—Conventional FGD (EPRI model)
- B—AFGD, own-and-operate arrangement
- C—Adds gypsum sales
- D—Adds emission allowance credits at \$300/ton, for 90% SO₂ removal
- E—Increases SO₂ removal to 95%

Advanced Flue Gas Desulfurization (AFGD) Demonstration Project. Final Technical Report, Vol. II: Project Performance and Economics. Pure Air on the Lake, L.P. April 1996. (Available from NTIS as DE96050313.)

Advanced Flue Gas Desulfurization Project: Public Design Report. Pure Air on the Lake, L.P. March 1990.

Advanced Flue Gas Desulfurization Demonstration Project—Project Performance Summary. U.S. Department of Energy. June 1999.

Demonstration of Innovative Applications of Technology for the CT-121 FGD Process

Project completed

Participant

Southern Company Services, Inc.

Additional Team Members

Georgia Power Company—host

Electric Power Research Institute—cofounder

Radian Corporation—environmental and analytical consultant

Ershigs, Inc.—fiberglass fabricator

Composite Construction and Equipment—fiberglass sustainment consultant

Acentech—flow modeling consultant

Ardaman—gypsum stacking consultant

University of Georgia Research Foundation—
 by-product utilization studies consultant

Location

Newnan, Coweta County, GA (Georgia Power Company's Plant Yates, Unit No. 1)

Technology

Chiyoda Corporation's Chiyoda Thoroughbred-121 (CT-121) advanced flue gas desulfurization (AFGD) process using the Jet Bubbling Reactor®

Plant Capacity/Production

100 MWe

Coal

Illinois No. 5 & No. 6 blend, 2.5% sulfur (baseline)
 Range of test coals 1.2–4.3% sulfur

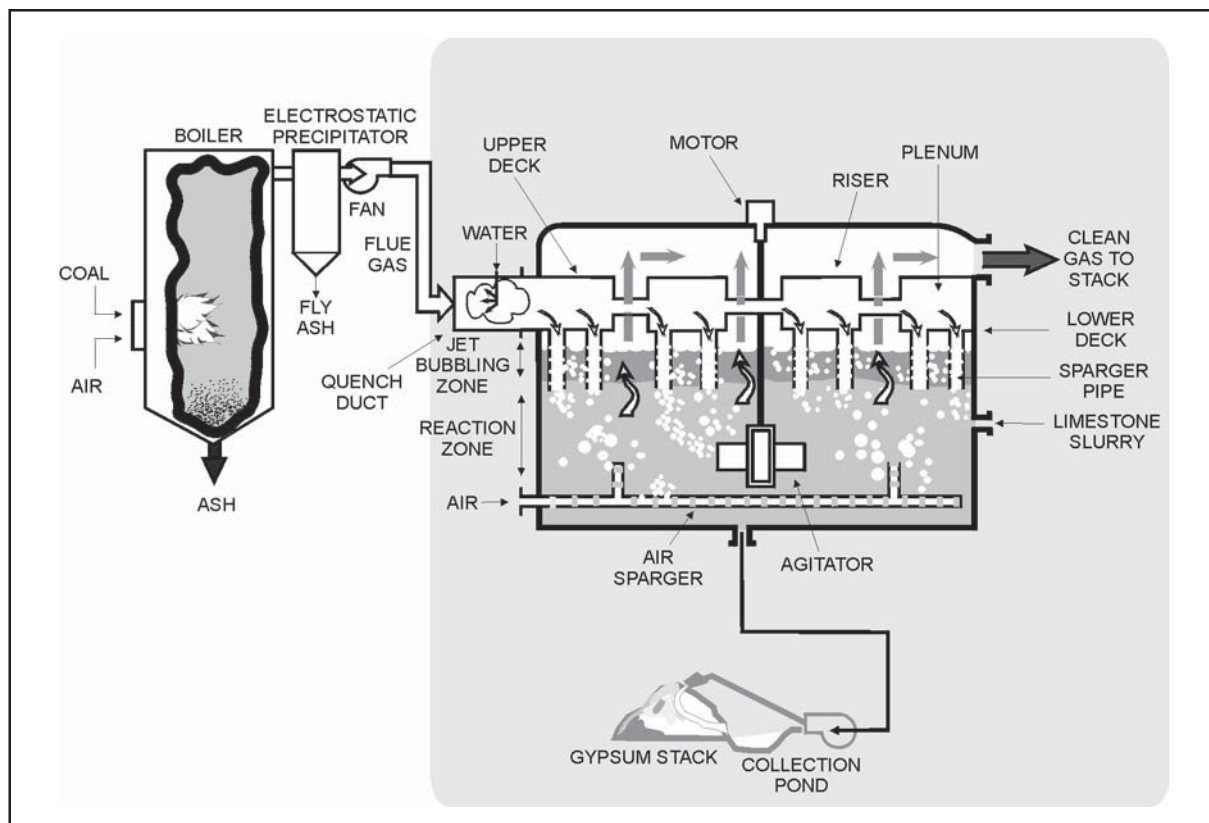

Project Funding

Total	\$43,074,996	100%
DOE	21,085,211	49
Participant	21,989,785	51

Project Objective

To demonstrate 90% SO₂ control at high reliability with and without simultaneous particulate control; to demonstrate reliable operation while eliminating spare absorber modules; to evaluate use of fiberglass-reinforced plastic (FRP) vessels to eliminate flue gas prescrubbing and re-heat, and to enhance reliability; and to evaluate use of gypsum to reduce waste management costs.

Technology/Project Description

The project demonstrated the CT-121 AFGD process, which uses a unique absorber design known as the Jet

Bubbling Reactor® (JBR). The process combines limestone AFGD reaction, forced oxidation, and gypsum crystallization in one process vessel. The process is mechanically and chemically simpler than conventional AFGD processes and can be expected to exhibit lower cost characteristics.

The flue gas enters underneath the scrubbing solution in the JBR. The SO₂ in the flue gas is absorbed and forms calcium sulfite (CaSO₃). Air is bubbled into the bottom of the solution to oxidize the calcium sulfite to form gypsum. The slurry is dewatered in a gypsum stack, which involves filling a diked area with gypsum slurry. Gypsum solids settle in the diked area by gravity, and clear water flows to a retention pond. The clear water from the pond is returned to the process.

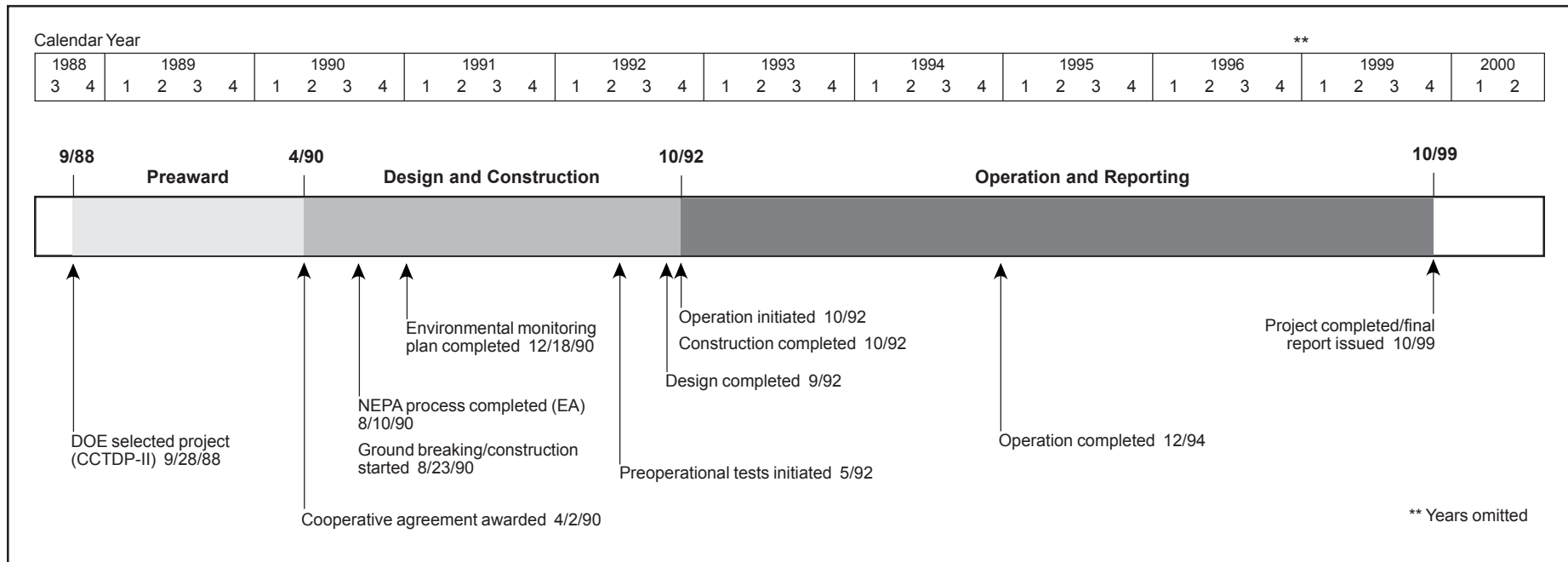

Results Summary

Environmental

- Over 90% SO₂ removal efficiency was achieved at SO₂ inlet concentrations of 1,000–3,500 ppm with limestone utilization over 97%.
- JBR achieved particulate removal efficiencies of 97.7–99.3% for inlet mass loadings of 0.303–1.392 lb/10⁶ Btu over a load range of 50–100 MWe.
- Capture efficiency was a function of particle size:
 - >10 microns—99% capture
 - 1–10 microns—90% capture
 - 0.5–1 micron—negligible capture
 - <0.5 micron—90% capture
- Hazardous air pollutant (HAP) testing showed greater than 95% capture of hydrogen chloride (HCl) and hydrogen fluoride (HF) gases, 80–98% capture of most trace metals, less than 50% capture of mercury and cadmium, and less than 70% capture of selenium.
- Gypsum stacking proved effective for producing wall-board/cement-grade gypsum.

Operational

- FRP-fabricated equipment proved durable both structurally and chemically, eliminating the need for a flue gas prescrubber and reheat.
- FRP construction combined with simplicity of design resulted in 97% availability at low ash loadings and 95% at high ash loadings, eliminating the need for a spare reactor module.
- Simultaneous SO₂ and particulate control were achieved at fly ash loadings similar to those of an electrostatic precipitator (ESP) that has marginal performance.

Economic

- Capital costs for project equipment, process, and startup were \$29 million, or \$293/kW at Plant Yates.
- Fixed O&M costs were \$354,000/yr (1994\$), and variable operating costs were \$34–64/ton of SO₂ removed, depending on specific test conditions.

- Generic plant costs were not estimated; however, elimination of the need for flue gas prescrubbing, reheat, and a spare module should result in capital requirements far below those of contemporary conventional flue gas desulfurization (FGD) systems.

Project Summary

The CT-121 AFGD process differs from the more common spray tower type of flue gas desulfurization systems in that a single process vessel is used in place of the usual spray tower/reaction tank/thickener arrangement. Pumping of reacted slurry to a gypsum transfer tank is intermittent. This allows crystal growth to proceed essentially uninterrupted, resulting in large, easily dewatered gypsum crystals (conventional systems employ large centrifugal pumps to move reacted slurry causing crystal attrition and secondary nucleation).

The demonstration spanned 27 months, including startup and shakedown, during which approximately 19,000 hours were logged. Exhibit 3-16 summarizes operating statistics. Elevated particulate loading included a short test with the electrostatic precipitator (ESP) completely deenergized, but the long-term testing was conducted with the ESP partially deenergized to simulate a more realistic scenario, *i.e.*, a CT-121 retrofit to a boiler with a marginally performing particulate collection device. The SO₂ removal efficiency was measured under five different inlet concentrations with coals averaging 2.5% sulfur and ranging from 1.2– 4.3% sulfur (as burned).

Exhibit 3-16
Operation of CT-121 Scrubber

	Low Ash Phase	Elevated Ash Phase	Cumulative for Project
Total test period (hr)	11,750	7,250	19,000
Scrubber available (hr)	11,430	6,310	18,340
Scrubber operating (hr)	8,600	5,210	13,810
Scrubber called upon (hr)	8,800	5,490	14,290
Reliability ^a	0.98	0.95	0.96
Availability ^b	0.97	0.95	0.97
Utilization ^c	0.73	0.72	0.75

^a Reliability = hours scrubber operated divided by the hours called upon to operate
^b Availability = hours scrubber available divided by the total hours in the period
^c Utilization = hours scrubber operated divided by the total hours in the period

Operating Performance

Use of FRP construction proved very successful. Because their large size precluded shipment, the JBR and limestone slurry storage tanks were constructed on site. Except for some erosion experienced at the JBR inlet transition duct, the FRP-fabricated equipment proved to be durable, both structurally and chemically. Because of the high corrosion resistance, the need for a flue gas pre-scrubber to remove chlorides was eliminated. Similarly, the FRP-constructed chimney proved resistant to the corrosive condensates in wet flue gas, eliminating the need for flue gas reheat.

Availability of the CT-121 scrubber during the low ash test phase was 97%. Availability dropped to 95% under the elevated ash loading conditions due largely to sparger tube plugging problems, precipitated by fly ash agglomeration on the sparger tube walls during high ash loading when the ESP was deenergized. The high reliability demonstrated verified that a spare JBR is not required in a commercial design offering.

Environmental Performance

Exhibit 3-17 shows SO₂ removal efficiency as a function of pressure drop across the JBR for five different inlet concentrations. The greater the pressure drop, the greater the depth of slurry traversed by the flue gas. As the SO₂ concentration increased, removal efficiency decreased, but adjustments in JBR fluid level could maintain the efficiency above 90% and, at lower SO₂ concentration levels, above 98%. Limestone utilization remained above 97% throughout the demonstration. Long-term particulate capture performance was tested with a partially deenergized ESP (approximately 90% efficiency), and is summarized in Exhibit 3-18. Analysis indicated that a large percentage of the outlet particulate matter is sulfate, likely a result of acid mist and gypsum carryover.

Exhibit 3-17
SO₂ Removal Efficiency

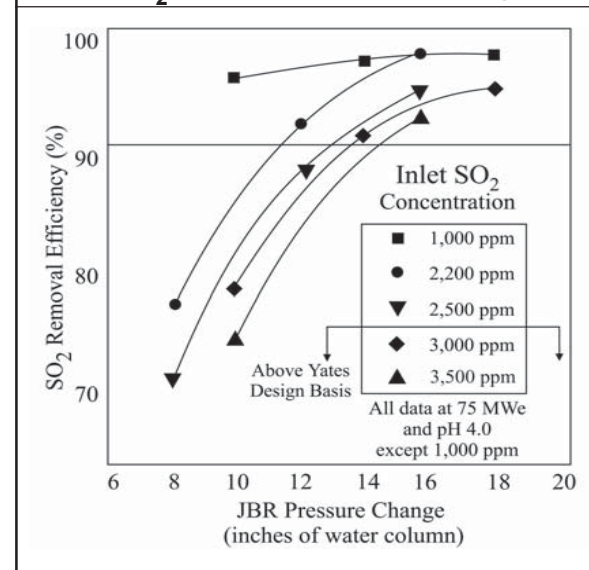

This reduces the estimate of ash mass loading at the outlet to approximately 70% of the measured outlet particulates.

For particulate sizes greater than 10 microns, capture efficiency was consistently greater than 99%. In the 1–10 micron range, capture efficiency was over 90%. Between 0.5 and 1 micron, the particulate removal dropped at times to negligible values, possibly due to acid mist carryover entraining particulates in this size range. Below 0.5 micron, the capture efficiency increased to over 90%. Calculated air toxics removals across the CT-121 JBR, based on the measurements taken during the demonstration, are shown in Exhibit 3-19.

As to solids handling, the gypsum stacking method proved effective in the long term. Although chloride content was initially high in the stack due to the closed loop nature of the process (with concentrations often exceeding 35,000 ppm), a year later the chloride concentration in the gypsum dropped to less than 50 ppm, suitable for wallboard and cement applications. The reduction in chloride content was attributed to rainwater washing the stack.

Exhibit 3-18
CT-121 Particulate Capture Performance
(ESP Marginally Operating)

JBR Pressure Change (inches of water column)	Boiler Load (MWe)	Inlet Mass Loading (lb/10 ⁶ Btu)	Outlet Mass Loading* (lb/10 ⁶ Btu)	Removal Efficiency (%)
18	100	1.288	0.02	97.7
10	100	1.392	0.010	99.3
18	50	0.325	0.005	98.5
10	50	0.303	0.006	98.0

*Federal NSPS is 0.03 lb/10⁶ Btu for units constructed after September 18, 1978. Plant Yates permit limit is 0.24 lb/10⁶ Btu as an existing unit.

Exhibit 3-19
CT-121 Air Toxics Removal
(JBR Components Only)

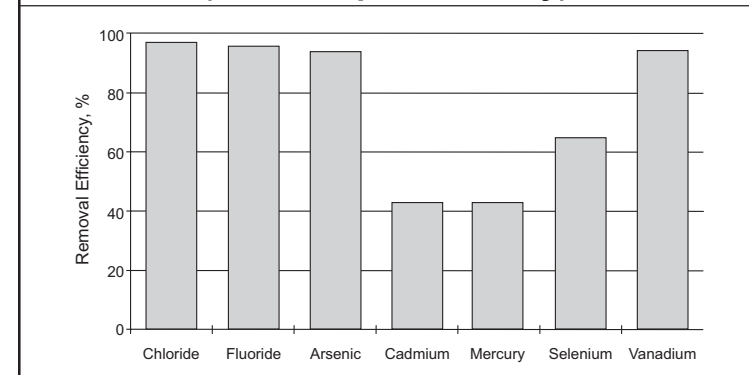

Economic Performance

The capital cost of the Plant Yates CT-121 project was \$29,335,979, or \$293/kW, which includes equipment, process, and start-up costs. The annual fixed O&M cost was \$354,000/yr. (1994\$). Variable operating cost was \$34–64/ton of SO₂ removed (1994\$), depending on specific test conditions.

FRP construction eliminates the need for prescrubbing and reheating flue gas. High system availability eliminates the need for a spare absorber module. Particulate removal capability eliminates the need for expensive (capital-intensive) ESP upgrades to meet increasingly strict environmental regulations.

Commercial Applications

Involvement of Southern Company (which owns Southern Company Services, Inc.), with more than 20,000 MWe of coal-fired generating capacity, is expected to enhance confidence in the CT-121 process among other large high-sulfur coal boiler users. This process will be applicable to 370,000 MWe of new and existing generating capacity by the year 2010. A 90% reduction in SO₂ emissions from only the retrofit portion of this capacity represents more than 10,500,000 tons/yr of potential SO₂ control.

Plant Yates continues to operate with the CT-121 scrubber as an integral part of the site’s CAAA compliance strategy.

The project received *Power* magazine’s 1994 Powerplant Award. Other awards include the Georgia Chapter of the Air and Waste Management Association’s 1994 Outstanding Achievement Award, the Georgia Chamber of Commerce’s 1993 Air Quality Citizen of the Year Award, and the Composites Institute (Society of Plastics Industries) 1996 Design Award of Excellence.

Contacts

Steve Woodfield, (205) 992-6223
 Southern Company
 P.O. Box 2625 / bin no. B223
 Birmingham, AL 35291
 (205) 257-7161 (fax)
 swwoodfi@southernco.com

Victor K. Der, DOE/HQ, (301) 903-2700
 victor.der@hq.doe.gov

Thomas A. Sarkus, NETL, (412) 386-5981
 sarkus@netl.doe.gov

References

- Demonstration of Innovative Applications of Technology for Cost Reductions to the CT-121 FGD Process. Final Report. Volumes 1-6.* Southern Company Services, Inc. January 1997.
- Comprehensive Report to Congress on the Clean Coal Technology Program: Demonstration of Innovative Applications of Technology for the CT-121 FGD Process.* Southern Company Services, Inc. Report No. DOE/FE-0158. U.S. Department of Energy. February 1990. (Available from NTIS as DE9008110.)
- Demonstration of Innovative Applications of Technology for the CT-121 FGD Process Project—Performance Summary.* U.S. Department of Energy. August 2002.

Environmental Control Devices

NO_x Control Technologies

Demonstration of Advanced Combustion Techniques for a Wall-Fired Boiler

Project completed

Participant

Southern Company Services, Inc. (SCS)

Additional Team Members

Southern Company—cofunder

Electric Power Research Institute (EPRI)—cofunder

Foster Wheeler Energy Corporation (Foster Wheeler)—
 technology supplier

Georgia Power Company—host

PowerGen—cofunder

U.K. Department of Trade and Industry—cofunder

EnTEC—technology supplier

Radian—technology supplier

Tennessee Technological University—technology supplier

Location

Coosa, Floyd County, GA (Georgia Power Company's
 Plant Hammond, Unit No. 4)

Technology

Foster Wheeler's low-NO_x burner (LNB) with advanced overfire air (AOFA) and EPRI's Generic NO_x Control Intelligent System (GNOCIS) computer software.

Plant Capacity/Production

500 MWe

Coal

Eastern bituminous coals, 1.7% sulfur

Project Funding

Total	\$15,853,900	100%
DOE	6,553,526	41
Participant	9,300,374	59

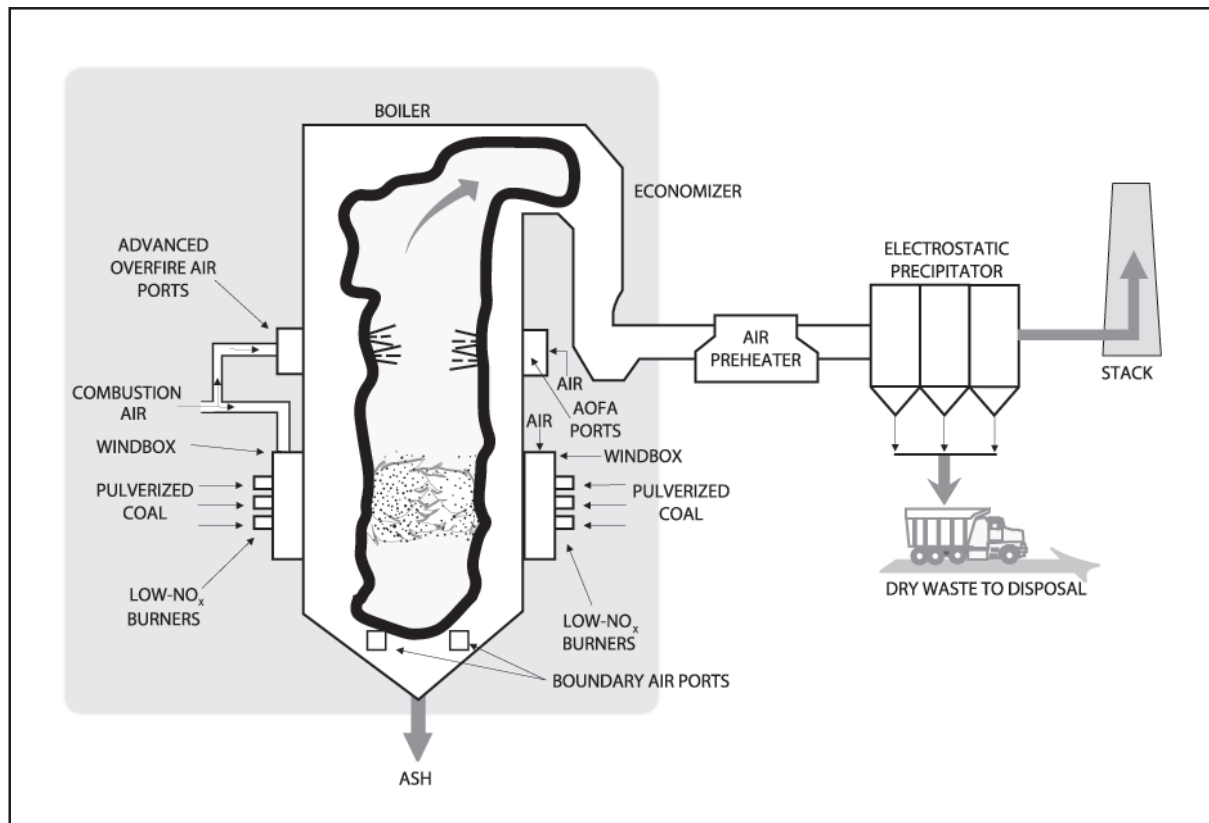

Project Objective

To achieve 50% NO_x reduction with the LNB/AOFA system; to determine the contributions of AOFA and LNB to NO_x reduction and the parameters for optimal LNB/AOFA performance; and to assess the long-term effects of LNB, AOFA, combined LNB/AOFA, and the GNOCIS advanced digital controls on NO_x reduction, boiler performance, and peripheral equipment performance. The project has been reopened and extended to demonstrate an overall unit optimization system.

Technology/Project Description

AOFA involves: (1) improving OFA mixing to enable operation of the burners below the air/fuel ratio theoretically required to complete combustion (sub-stoichiometric), without increasing combustible losses; and (2) introducing "boundary air" at the boiler walls to prevent corrosion caused by the reducing atmosphere.

In the Foster Wheeler Controlled Flow/Split Flame (CFSF) LNB, fuel and air mixing is staged by regulating the primary air/fuel mixture, velocities, and turbulence to create a fuel-rich core with sufficient air to sustain combustion at a severely sub-stoichiometric air/fuel ratio. The burner also controls the rate at which additional air, necessary to complete combustion, is mixed with the flame solids and gases so as to maintain a deficiency of oxygen until the remaining combustibles fall below the peak NO_x-producing temperature (around 2,800 °F). The final excess air then can be allowed to mix with the unburned products so that combustion is completed at a relatively low temperature. The CFSF LNB splits the coal/air mixture into four streams, which minimizes coal and air mixing and combustion staging.

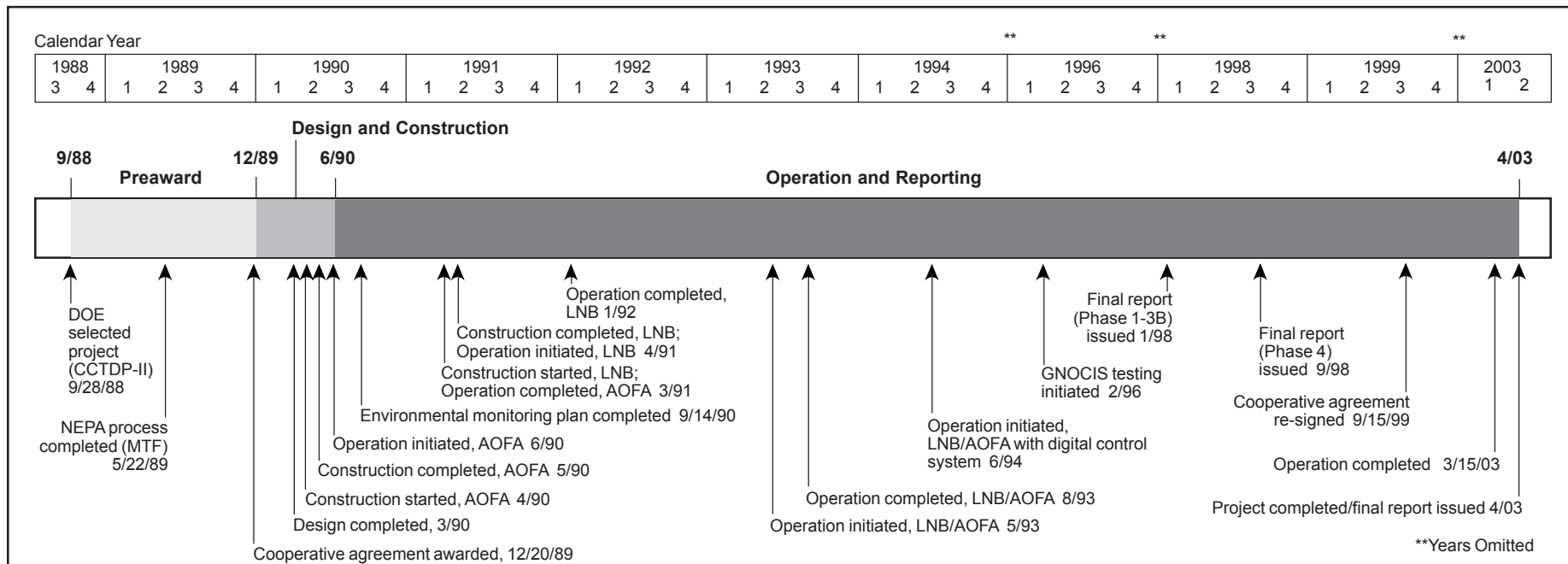

Results Summary

Environmental

- Using LNB alone, long-term NO_x emissions were 0.65 lb/10⁶ Btu, representing a 48% reduction from baseline conditions (1.24 lb/10⁶ Btu).
- Using AOFA only, long-term NO_x emissions were 0.94 lb/10⁶ Btu, representing a 24% reduction from baseline conditions.
- Using LNB/AOFA, long-term NO_x emissions were 0.40 lb/10⁶ Btu, representing a 68% reduction from baseline conditions.
- Chemical emissions testing showed no evidence of organic compound emissions resulting from the combustion modifications installed for NO_x control. Trace element control, except for mercury and selenium, proved to be a function of electrostatic precipitator (ESP) performance.

Operational

- AOFA accounted for an incremental NO_x reduction beyond the use of LNB of approximately 17%, with additional reductions resulting from other operational changes.
- GNOICIS achieved a boiler efficiency gain of 0.5 percentage points, a reduction in fly ash loss-on-ignition (LOI) levels of 1–3 percentage points, and a reduction in NO_x emissions of 10–15% at full load.
- Fly ash LOI increased from a baseline of 7% (corrected to representative excess oxygen conditions) to 10% with AOFA and 8% with LNB and LNB/AOFA, despite significant improvements in coal fineness.

Economic

- Capital cost for a 500-MWe wall-fired unit is \$8.8/kW for AOFA alone, \$10.0/kW for LNB alone, \$18.8/kW for LNB/AOFA, and \$0.5/kW for GNOICIS.
- Estimated cost of NO_x removal is \$79/ton using LNB/AOFA in a baseload dispatch scenario as experienced at Plant Hammond.

Project Summary

SCS conducted baseline characterization of the unit in an “as-found” condition from August 1989 to April 1990. The AOFA system was tested from August 1990 to March 1991. Following installation of the LNBs in the second quarter of 1991, the LNBs were tested from July 1991 to January 1992, excluding a three-month delay when the plant ran at reduced capacity. Post-LNB increases in fly ash LOI, along with increases in combustion air requirements and fly ash loading to the electrostatic precipitator (ESP), adversely affected the unit’s stack particulate emissions. The LNB/AOFA testing was conducted from January 1992 to August 1993, excluding downtime for a scheduled outage and for portions of the test period due to excessive particulate emissions. However, an ammonia flue gas conditioning system was added to improve ESP performance, which enabled the unit to operate at full load, and allowed testing to continue.

Operational Performance

LOI increased for the AOFA, LNB, and LNB/AOFA phases, as shown in Exhibit 3-20, despite improved mill performance due to the replacement of the mills. Increased LOI was a concern not only because of the associated efficiency loss, but also due to a potential loss of

fly ash sales. The increased carbon in the fly ash renders the material unsuitable for use in making concrete.

During October 1992, SCS conducted parametric testing to determine the relationship between NO_x and LOI emissions. The parameters tested were: excess oxygen, mill coal flow bias, burner sliding tip position, burner outer register position, and burner inner register position. Nitrogen oxide emissions and LOI levels varied from 0.44–0.57 lb/10⁶ Btu and 3–10%, respectively. As expected, excess oxygen levels had considerable effect on both NO_x and LOI. The results showed that there is some flexibility in selecting the optimum operating point and making trade-offs between NO_x emissions and fly ash LOI; however, much of the variation was the result of changes in excess oxygen. This can be more clearly seen in Exhibit 3-21 in which all sensitivities are plotted. This exhibit shows that, for excess oxygen, mill bias, inner register, and sliding tip, any adjustments to reduce NO_x emissions are at the expense of increased fly ash LOI. In contrast, the slope of the outer register adjustment suggests that improvement in both NO_x emissions and LOI can be achieved by adjustment of this damper. However, due to the relatively small impact of the outer register adjustment on both NO_x and LOI, it is likely the positive NO_x /LOI slope is an artifact of process noise.

A subsidiary goal of the project was to evaluate advanced instrumentation and controls (I&C) as applied to combustion control. The need for more sophisticated I&C equipment is illustrated in Exhibit 3-22. There are trade-offs in boiler operation, e.g., as excess air increases, NO_x increases, LOI decreases, and boiler losses increase. The goal is to find and maintain

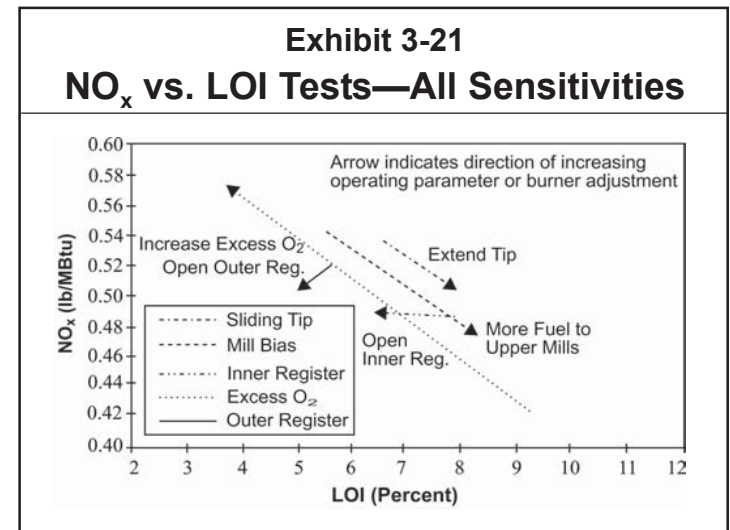

an optimal operating condition. The instrumentation and control (I&C) systems tested included GNOCIS and carbon-in-ash analyzers.

The GNOCIS software applies an optimizing procedure to identify the best set points for the plant, which are implemented automatically without operator intervention (closed-loop), or conveyed to the plant operators for implementation (open-loop). The major elements of GNOCIS are shown in Exhibit 3-23. The GNOCIS system provided advice that reduced NO_x emissions by 10–15% at full load, while improving the heat rate or reducing fly ash LOI by 1–3 percentage points.

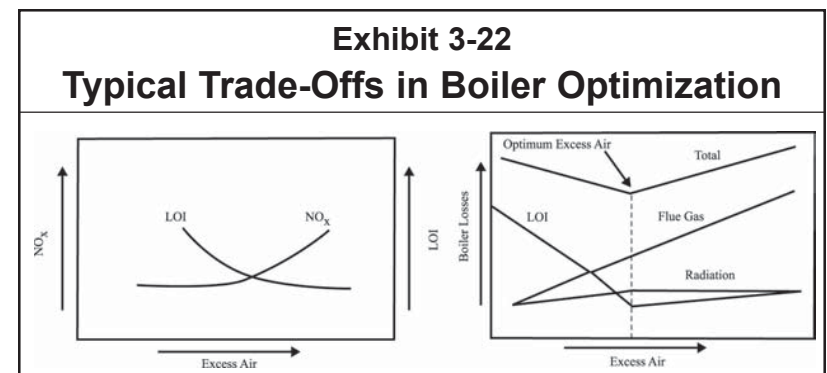
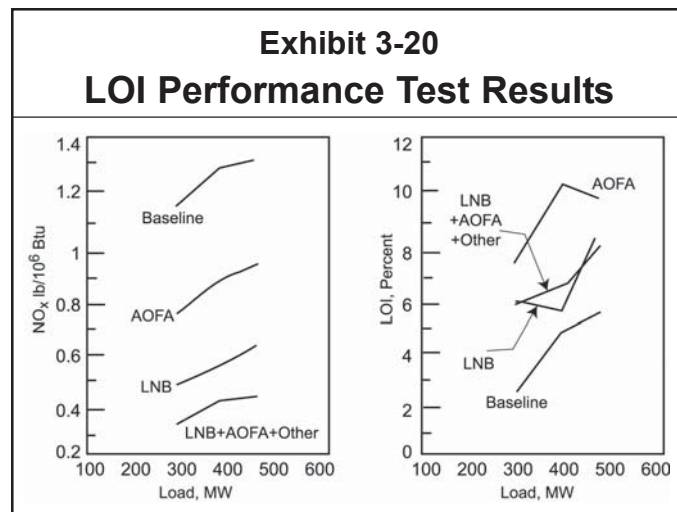
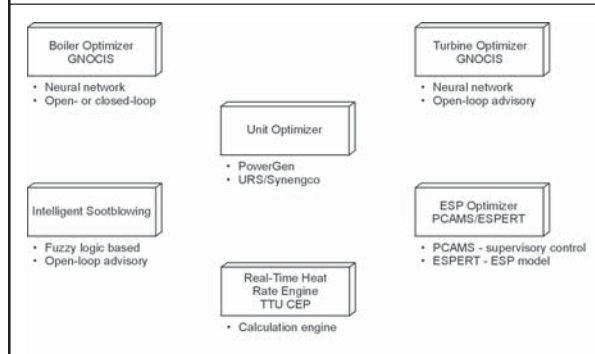

Exhibit 3-23 Major Elements of Optimization System



Environmental Performance

Long-term testing showed that the AOFA, LNBs, and LNB/AOFA provide full-load NO_x reductions of 24, 48, and 68%, respectively. Although the long-term LNB/AOFA NO_x level represents a 68% reduction from baseline levels, a substantial portion of the incremental change in NO_x emissions between the LNB and the LNB/AOFA configurations is the result of operational changes and is not the result of adding AOFA.

During the LNB/AOFA test phase a total of 63 days of valid long-term NO_x emissions data was collected. Based on this data set, the full-load, long-term NO_x emissions were 0.40 lb/10⁶ Btu, which was consistent with earlier short-term test data. Earlier long-term testing had resulted in NO_x emissions of 0.94 lb/10⁶ Btu for AOFA only and 0.65 lb/10⁶ Btu for LNB only.

Chemical emissions testing showed no evidence of organic compound emissions resulting from the combustion modifications installed for NO_x control. Trace element control, except for mercury and selenium, proved to be a function of electrostatic precipitator (ESP) performance. Only a small portion of the mercury and selenium, which adopt a vapor phase, and none of the vapor-phase chlorine (as hydrochloric acid) and fluorine (as hydrofluoric acid) were captured.

Economic Performance

Estimated capital costs for a commercial 500-MWe wall-fired installation are: AOFA—\$8.8/kW, LNB—\$10.0/kW, LNB/AOFA—\$18.8/kW, and GNOCIS—\$0.5/kW. Annual O&M costs and NO_x reductions depend on the assumed load profile. Based on the actual load profile observed in the testing, the estimated annual O&M cost increase for LNB/AOFA is \$333,351. Efficiency is decreased by 1.3 percent, and the NO_x reduction is 68 percent of baseline, or 11,615 tons/year at full load. The capital cost is \$8,300,000 and the calculated cost of NO_x removed is \$79/ton for the Hammond baseload dispatch scenario.

The addition of GNOCIS to the LNB/AOFA, using the actual load profile observed in the testing, results in a range of costs depending on whether the unit is operated to maximize NO_x removal efficiency, or LOI. For the maximum NO_x removal case, the efficiency is improved by 0.6 percent, the annual O&M cost is decreased by \$228,058, the incremental NO_x reduction is 11 percent (696 tons/year), and the capital cost is \$250,000. The calculated cost per ton of NO_x removed is -\$299 (net gain due to increased efficiency).

Project Extension

On September 15, 1999, the cooperative agreement was extended and work began on the design and installation of an overall unit optimization system. The work has been carried out as part of Phase 4 of the project. The overall goal of Phase 4 is to demonstrate on-line optimization techniques, including use of a real-time heat rate monitor, for power plant processes and for the unit as a whole. The major tasks include unit optimization, boiler optimization, automated sootblowing, and precipitator modeling/optimization.

Commercial Applications

The technology is applicable to the 411 existing pre-NSPS dry-bottom wall-fired boilers in the United States, which burn a variety of coals. The GNOCIS technology is applicable to all fossil fuel-fired boilers, including units fired with natural gas and units cofiring coal and natural gas. The host has retained the technologies for commercial use.

Contacts

John N. Sorge, Research Engineer, (205) 257-7426
Southern Company Services, Inc.
Mail stop 14N-8195
P.O. Box 2641
Birmingham, AL 35291-8195
(205) 257-5367 (fax)
jnsorge@southernco.com

Victor K. Der, DOE/HQ, (301) 903-2700
victor.der@hq.doe.gov

James R. Longanbach, NETL, (304) 285-4659
james.longanbach@netl.doe.gov

References

500-MW Demonstration of Advanced Wall-Fired Combustion Techniques for the Reduction of Nitrogen Oxide (NO_x) Emissions from Coal-Fired Boilers. Phase 4—Digital Control System and Optimization. Southern Company Services, Inc. September 1998.

500-MW Demonstration of Advanced Wall-Fired Combustion Techniques for the Reduction of Nitrogen Oxide (NO_x) Emissions from Coal-Fired Boilers. Phases 1-3B, Final Report. Southern Company Services, Inc. January 1998.

Demonstration of Coal Reburning for Cyclone Boiler NO_x Control

Project completed

Participant

The Babcock & Wilcox Company

Additional Team Members

Wisconsin Power and Light Company—cofunder and host

Sargent and Lundy—engineer for coal handling

Electric Power Research Institute—cofunder

State of Illinois, Department of Energy and Natural Resources—cofunder

Utility companies (14 cyclone boiler operators)—cofundors

Location

Cassville, Grant County, WI (Wisconsin Power and Light Company's Nelson Dewey Station, Unit No. 2)

Technology

The Babcock & Wilcox Company's Coal Reburning System (Coal Reburning)

Plant Capacity/Production

100 MWe

Coal

Illinois Basin bituminous (Lamar), 1.15% sulfur, 1.24% nitrogen

Powder River Basin (PRB) subbituminous, 0.27% sulfur, 0.55% nitrogen

Project Funding

Total	\$13,646,609	100%
DOE	6,340,788	46
Participant	7,305,821	54

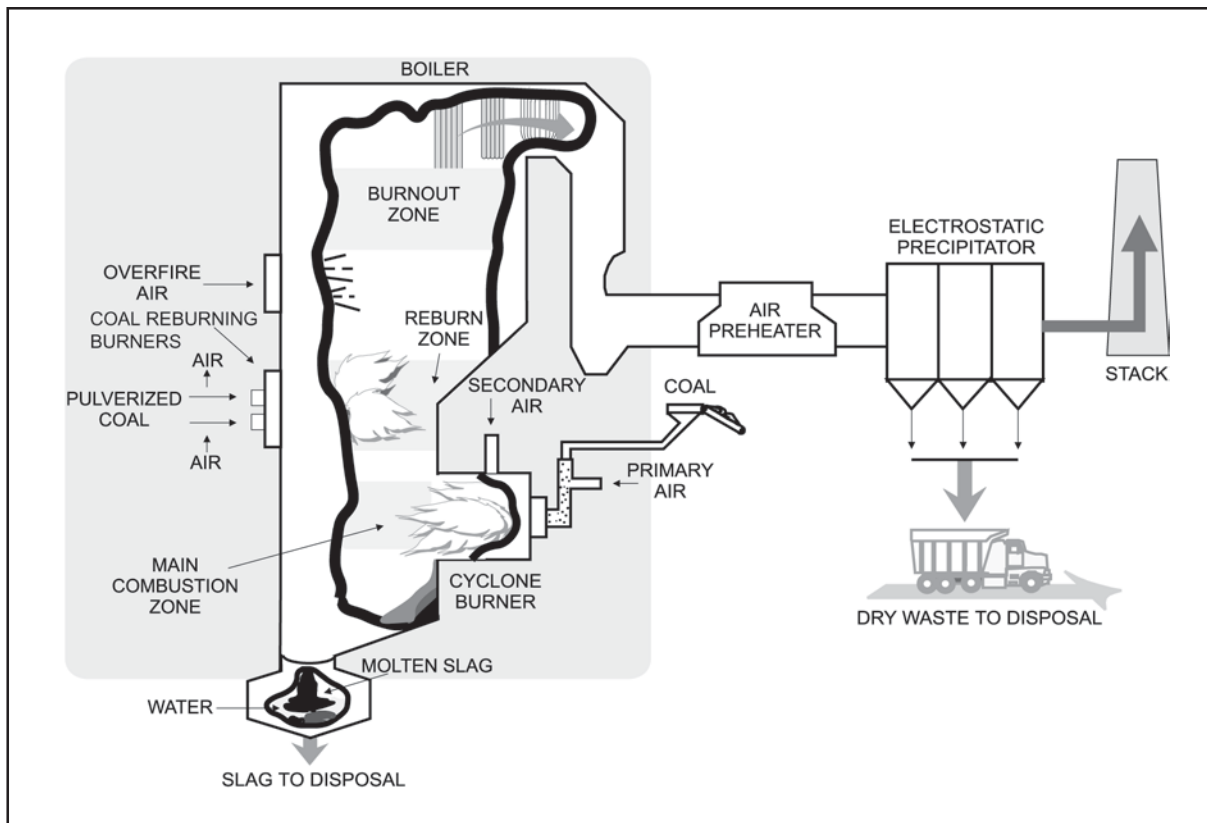

Project Objective

To demonstrate the technical and economic feasibility of Coal Reburning to achieve greater than 50% reduction in NO_x emissions with no serious impact on cyclone combustor operation, boiler performance, or other emission streams.

Technology/Project Description

Babcock & Wilcox Coal Reburning reduces NO_x in the furnace through the use of multiple combustion zones. The main combustion zone uses 70–80% of the total heat-equivalent fuel input to the boiler, and slightly less than normal combustion air input. The balance of the coal (20–30%), along with significantly less than the theoretically determined requirement of air, is fed to the reburning zone above the cyclones to create an oxygen-deficient condition. The NO_x formed in the cyclone burners reacts

with the resultant reducing flue gas and is converted into elemental nitrogen in this zone. Completion of the combustion process occurs in the third zone, called the burnout zone, where the balance of the combustion air is introduced.

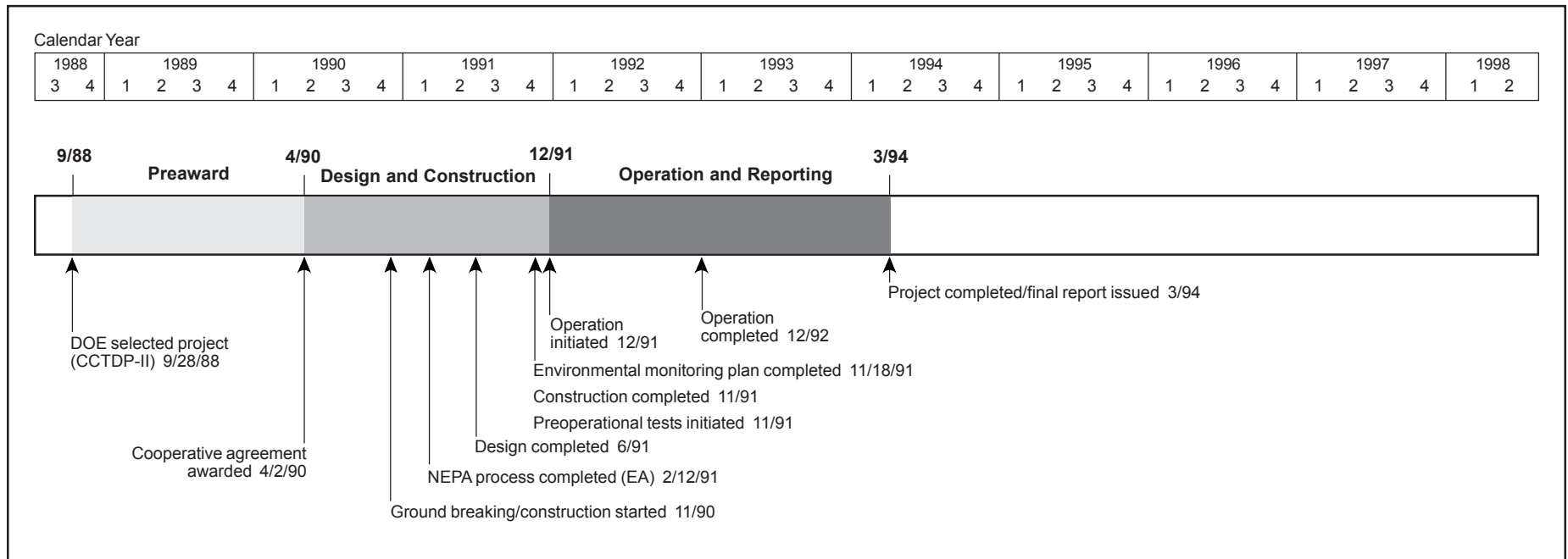

Results Summary

Environmental

- Coal Reburning achieved greater than 50% NO_x reduction at full load with Lamar bituminous and PRB sub-bituminous coals.
- Reburning-zone stoichiometry had the greatest effect on NO_x control.
- Gas recirculation was vital to maintaining reburning-zone stoichiometry while providing necessary burner cooling, flame penetration, and mixing.
- Opacity levels and electrostatic precipitator (ESP) performance were not affected by Coal Reburning with either coal tested.
- Optimal Coal Reburning heat input was 29–30% at full load and 33–35% at half to moderate loads.

Operational

- No major boiler performance problems were experienced with Coal Reburning operations.
- Boiler turndown capability was 66%, exceeding the 50% goal.

- ESP efficiency improved slightly during Lamar coal testing and did not change with PRB coal.
- Coal fineness levels above the nominal 90% through 200 mesh were maintained, reducing unburned carbon losses (UBCL).
- UBCL was the only major contributor to boiler efficiency loss, which was 0.1, 0.25, and 1.5 percentage points at loads of 110, 82, and 60 MWe, respectively, when using Lamar coal. With PRB coal, the efficiency loss ranged from zero at full load to 0.3 percentage points at 60-MWe.
- Superior flame stability was realized with PRB coal, contributing to better NO_x control than with Lamar coal.
- Expanded volumetric fuel delivery with reburning burners enabled switching to PRB low-rank coal without boiler derating.

Economic

- Capital costs for 110 and 605 MWe plants were \$66/kW and \$43/kW, respectively (1990\$).

- Levelized 10- and 30-year busbar power costs for a 110-MWe plant were 2.4 and 2.3 mills/kWh, respectively (constant 1990\$).
- Levelized 10- and 30-year busbar power costs for a 605-MWe plant were 1.6 and 1.5 mills/kWh, respectively (constant 1990\$).

Project Summary

Although cyclone boilers represent only 8.5% of the pre-NSPS coal-fired generating capacity, they contribute 12% of the NO_x formed by pre-NSPS coal-fired units. This is due to the cyclone combustor's inherent turbulent, high-temperature combustion process. However, at the time of this demonstration, there was no cost-effective combustion modification available for cyclone boiler NO_x control.

Babcock & Wilcox Coal Reburning offers an economic and operationally sound response to the environmental requirements. This technology avoids cyclone combustor modification and associated performance complications, and provides an alternative to postcombustion NO_x control options, such as SCR, which have relatively high capital and/or operating costs.

The majority of the testing was performed firing Illinois Basin bituminous coal (Lamar), because it is typical of the coal used by many utilities operating cyclones. Subbituminous PRB coal tests were performed to evaluate the effect of coal switching on reburning operation. Wisconsin Power and Light's strategy to meet Wisconsin's sulfur emission limitations as of January 1, 1993, was to fire low-sulfur coal.

Environmental Performance

Three sequential tests of Coal Reburning used Lamar coal. Parametric optimization testing set up the automatic controls. Performance testing evaluated the unit in full automatic control at set load points. Long-term testing assessed performance in a load-following mode. PRB coal was used for parametric optimization and performance modes. Exhibit 3-24 shows changes in NO_x emissions and boiler efficiency using the reburning system for various load conditions and coal types.

Coal Reburning tests on both the Lamar and PRB coals indicated that variation of reburning-zone stoichiometry was the most critical factor in changing NO_x emissions levels. The reburning-zone stoichiometry can be varied by alternating the air flow quantities (oxygen availability) to the reburning burners, the percent reburning heat input, the gas recirculation flow rate, or the cyclone stoichiometry.

Hazardous air pollutant (HAP) testing was performed using Lamar test coal. HAP emissions were generally well within expected levels, and emissions with Coal Reburning were comparable to baseline operation. No major effect of reburning on trace-metals partitioning was discernible. None of the 16 targeted polynuclear aromatic semi-volatile organics (controlled under Title III of CAAA) were present in detectable concentrations, at a detection limit of 1.2 parts per billion.

Operational Performance

For Lamar coal, the full-, medium-, and low-load efficiency losses due to unburned carbon were higher than the baseline by 0.1, 0.25, and 1.5 percentage points, respectively. Full-, medium-, and low-load efficiency losses with PRB coal were 0.0, 0.2, and 0.3 percentage points, respectively. Coal Reburning burner flame stability improved with PRB coal.

During Coal Reburning operation with Lamar coal, the operators continually monitored boiler internals for increased ash deposition and the on-line perfor-



Wisconsin Power and Light Company's Nelson Dewey Station hosted the successful demonstration of Coal Reburning.

mance monitoring system for heat transfer changes. At no time throughout the system optimization or long-term operation period were any slagging or fouling problems observed. In fact, during scheduled outages, internal boiler inspections revealed that boiler cleanliness had actually improved. Extensive ultrasonic thickness measurements were taken of the furnace wall tubes. No observable decrease in wall tube thickness was measured.

Another significant finding was that Coal Reburning minimizes and possibly eliminates a 10–25% derating normally associated with switching to subbituminous coal in a cyclone unit. This derating results from using a lower Btu fuel in a cyclone combustor, which has a limited coal feed capacity. Coal Reburning transferred about 30% of the coal feed out of the cyclone to the reburning burners, bringing the cyclone feed rate down to a manageable level while maintaining full-load heat input to the unit.

Economic Performance

An economic analysis of total capital and levelized revenue requirements was conducted using the "Electric Power Research Institute Economic Premises" for retrofit of 110- and 605-MWe plants. In addition, annualized costs per ton of NO_x removed were developed for 110- and 605-MWe plants over both 10 and 30 years. The results of these analyses are shown in Exhibit 3-25. These values assumed typical retrofit conditions and did not

Exhibit 3-24
Coal Reburning Test Results

	Boiler Load		
	110 MWe	82 MWe	60 MWe
Lamar coal			
NO _x (lb/10 ⁶ Btu/% reduction)	0.39/52	0.36/50	0.44/36
Boiler efficiency losses due to unburned carbon (%)	0.1	0.25	1.5
Powder River Basin coal			
NO _x (lb/10 ⁶ Btu/% reduction)	0.34/55	0.31/52	0.30/53
Boiler efficiency losses due to unburned carbon (%)	0.0	0.2	0.3

take into account any fuel savings from use of low-rank coal. The pulverizers and associated coal handling were taken into account. Site-specific parameters that can significantly impact these retrofit costs included the state of the existing control system, availability of flue gas recirculation, space for coal pulverizers, space for reburning burners and overfire air ports within the boiler, scope of coal-handling modification, sootblowing capacity, ESP capacity, steam temperature control capacity, and boiler circulation considerations.

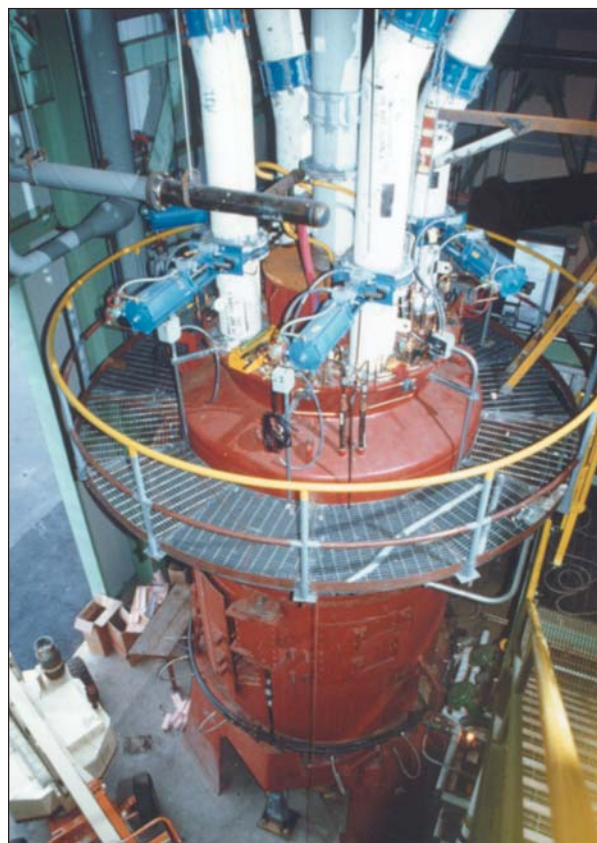

The coal pulverizer is part of Babcock & Wilcox coal reburning. This system has been retained by Wisconsin Power and Light for NO_x emission control at the Nelson Dewey Station.

Commercial Applications

Coal Reburning is a retrofit technology applicable to a wide range of utility and industrial cyclone boilers. The current U.S. coal reburning market is estimated to be approximately 27,000 MWe and consists of about 89 units ranging from 100–1,150 MWe with most in the 100- to 300-MWe range.

The project technology has been retained by Wisconsin Power and Light for commercial use.

Contacts

Dot K. Johnson, (330) 860-1757
 The Babcock & Wilcox Company
 20 South Van Buren Avenue
 P.O. Box 351
 Barberton, OH 44203-0351
 (330) 860-2348 (fax)
 dkjohnson1@babcock.com

Victor K. Der, DOE/HQ, (301) 903-2700
 victor.der@hq.doe.gov

John C. McDowell, NETL, (412) 386-6175
 mcdowell@netl.doe.gov

References

Demonstration of Coal Reburning for Cyclone Boiler NO_x Control: Final Project Report. Report No. DOE/PC/89659-T16. The Babcock & Wilcox Company. February 1994. (Available from NTIS as DE94013052, Appendix 1 as DE94013053, Appendix 2 as DE94013054.)

Public Design Report: Coal Reburning for Cyclone Boiler NO_x Control. The Babcock & Wilcox Company. August 1991. (Available from NTIS as DE92012554.)

Comprehensive Report to Congress on the Clean Coal Program: Demonstration of Coal Reburning for Cyclone Boiler NO_x Control. Report No. DOE/FE-0157. U.S. Department of Energy. February 1990. (Available from NTIS as DE90008111.)

Exhibit 3-25 Coal Reburning Economics (1990 Constant Dollars)

Costs	Plant Size	
	110 MWe	605 MWe
Total capital cost (\$/kW)	66	43
Levelized busbar power cost (mills/kWh)		
10-year life	2.4	1.6
30-year life	2.3	1.5
Annualized cost (\$/ton of NO _x removed)		
10-year life	1,075	408
30-year life	692	263

Full-Scale Demonstration of Low-NO_x Cell Burner Retrofit

Project completed

Participant

The Babcock & Wilcox Company

Additional Team Members

The Dayton Power and Light Company—cofunder and host

Electric Power Research Institute—cofunder

Ohio Coal Development Office—cofunder

Tennessee Valley Authority—cofunder

New England Power Company—cofunder

Duke Power Company—cofunder

Allegheny Power System—cofunder

Centerior Energy Corporation—cofunder

Cincinnati Gas & Electric Company—cofunder

Columbus and Southern Power Company—cofunder

Location

Aberdeen, Adams County, OH (Dayton Power and Light Company's J.M. Stuart Plant, Unit No. 4)

Technology

The Babcock & Wilcox Company's low-NO_x cell-burner (LNCB[®]) system

Plant Capacity/Production

605 MWe

Coal

Bituminous, 1.2% sulfur

Project Funding

Total	\$11,233,392	100%
DOE	5,442,800	48
Participant	5,790,592	52

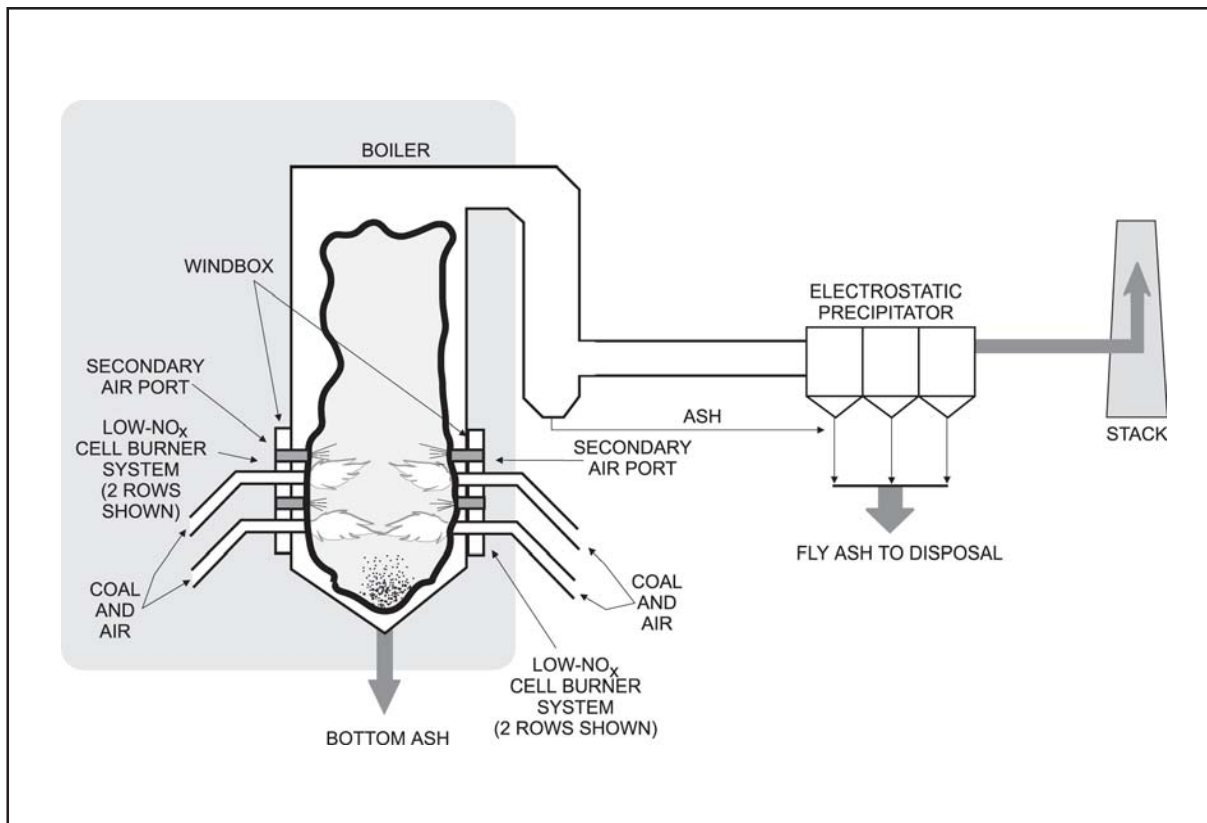

Project Objective

To demonstrate, through the first commercial-scale full burner retrofit, the cost-effective reduction of NO_x from a large, baseload coal-fired utility boiler with LNCB[®] technology and to achieve at least a 50% NO_x reduction without degradation of boiler performance at less cost than that of conventional low-NO_x burners.

Technology/Project Description

The LNCB[®] technology replaces the upper coal nozzle of the standard two-nozzle cell burner with a secondary air port. The lower burner coal nozzle is enlarged to the same fuel input capacity as the two standard coal nozzles. The LNCB[®] operates on the principle of staged combustion to reduce NO_x emissions. Combustion is staged by providing only about 58% of the air theoretically required for complete combustion through the lower burner and the

balance of the air through the secondary air port (NO_x port).

The demonstration was conducted on a Babcock & Wilcox-designed, supercritical once-through boiler equipped with an electrostatic precipitator (ESP). This unit, which is typical of cell-burner boilers, contained 24 two-nozzle cell burners arranged in an opposed-firing configuration. Twelve burners (arranged in two rows of six burners each) were mounted on each of two opposing walls of the boiler. All 24 standard cell burners were removed and 24 new LNCBs[®] were installed. Alternate LNCBs[®] on the bottom rows were inverted, with the air port then being on the bottom to ensure complete combustion in the lower furnace.

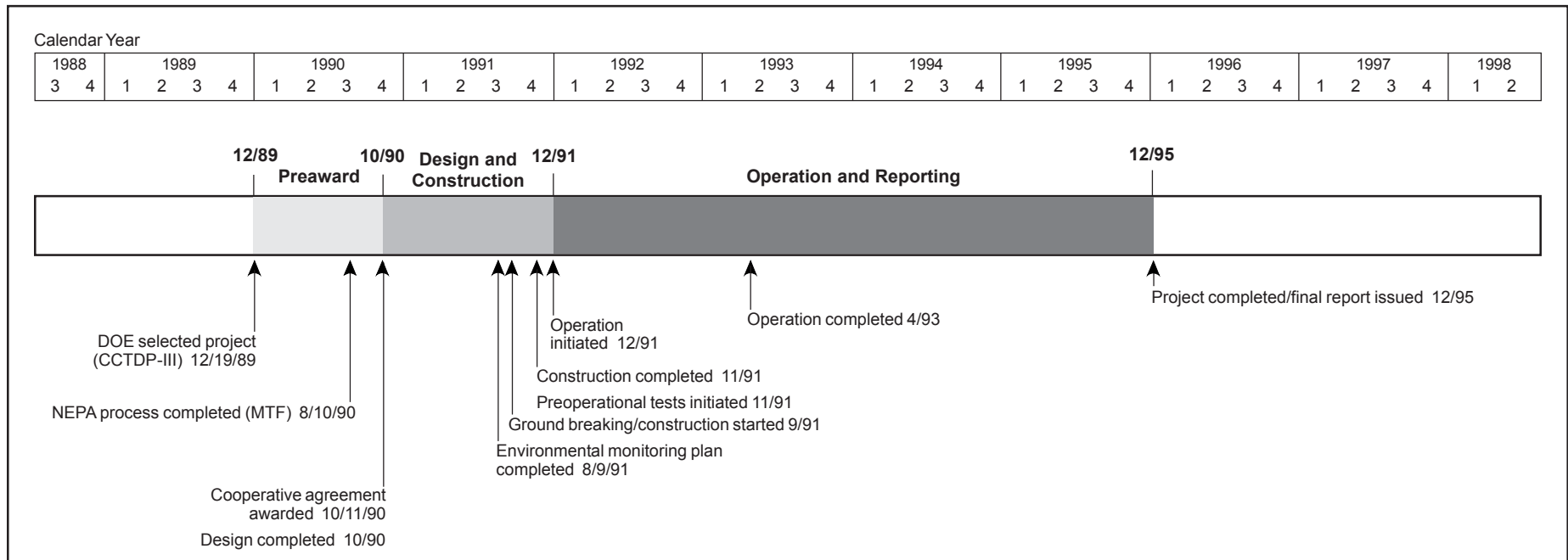

Results Summary

Environmental

- Short-term optimization testing (all mills in service) showed NO_x reductions in the range of 53.0–55.5%, 52.5–54.7%, and 46.9–47.9% at loads of 605 MWe, 460 MWe, and 350 MWe, respectively.
- Long-term testing at full load (all mills in service) showed an average NO_x reduction of 58% (over 8 months).
- Long-term testing at full load (one mill out of service) showed an average NO_x reduction of 60% (over 8 months).
- Carbon monoxide (CO) emissions averaged 28–55 ppm at full load with LNCB[®] in service.
- Fly ash increased, but ESP performance remained virtually unchanged.

Operational

- Unit efficiency remained essentially unchanged.
- Unburned carbon losses (UBCL) increased by approximately 28% for all tests, but boiler efficiency loss was

offset by a decrease in dry gas loss due to a lower boiler economizer outlet gas temperature.

- Boiler corrosion with LNCB[®] was roughly equivalent to boiler corrosion rates prior to retrofit.

Economic

- Capital cost for a 600 MWe plant in the Midwest, with a 1.2 lb/10⁶ Btu initial NO_x emission rate and 65% capacity factor, was \$9/kW (1994\$).
- Levelized cost (15-year) for the same 600 MWe plant was estimated at 0.284 mills/kWh and \$96.48/ton of NO_x removed (constant 1994\$).

Project Summary

Utility boilers equipped with cell burners represent 7.4% or approximately 24,000 MWe of pre-NSPS coal-fired generating capacity. Cell burners are designed for rapid mixing of fuel and air. The tight burner spacing and rapid mixing minimize flame size while maximizing the heat release rate and unit efficiency. Combustion efficiency is good, but the rapid heat release produces relatively large quantities of NO_x .

To reduce NO_x emissions, the LNCB[®] has been designed to stage mixing of fuel and combustion air. A key design criterion was accomplishing delayed fuel-air mixing with no modifications to boiler walls. The plug-in LNCB[®] design reduces material costs and outage time required to complete the retrofit, compared to installing conventional, internally staged low- NO_x burners, thereby providing a lower cost alternative to address NO_x reduction requirements for cell burners.

Environmental Performance

The initial LNCB[®] configuration resulted in excessive CO and hydrogen sulfide (H_2S) emissions. Through modeling, a revised configuration was developed (inverting alternate burners on the lower rows), which addressed the problem without compromising boiler performance. The modification served to validate model capabilities.

Following parametric testing to establish optimal operating modes, a series of optimization tests were conducted on the LNCB[®] to assess environmental and operational performance. Two sets of measurements were taken, one by Babcock & Wilcox and the other by an independent company, to validate data accuracy. Consequently, the data provided is a range reflecting the two measurements.

The average NO_x emissions reduction achieved at full load with all mills in service ranged from 53.0–55.5%. With one mill out of service at full load, the average NO_x reduction ranged from 53.3–54.5%. Average NO_x reduction at intermediate load (about 460 MWe) ranged from 52.5–54.7%. At low loads (about 350 MWe), average NO_x reduction ranged from 46.9–47.9%. NO_x emissions were monitored over the long term at full load with all mills in service and one mill out of service. Each test spanned an 8-month period. The NO_x emission reductions

realized were 58% for all mills in service and about 60% for one mill out of service.

Complications arose in assessing CO emissions relative to baseline because baseline calibration was not sufficiently refined. However, accurate measurements were made with LNCB[®] in service. Carbon monoxide emissions were corrected for 3.0% O_2 and measured at full, intermediate, and low loads. The range of CO emissions at full load with all mills in service was 28–55 ppm, and 20–38 ppm with one mill out of service. At intermediate loads (about 460 MWe), CO emissions were 28–45 ppm, and at low loads (about 350 MWe), 5–27 ppm.

Particulate emissions were minimally impacted. The LNCB[®] had little effect on fly ash resistivity, largely due to SO_3 injection, and therefore ESP removal efficiency remained very high. Baseline ESP collection efficiencies for full load with all mills in service, full load with one mill in service, and intermediate load with one mill out of service were 99.50%, 99.49%, and 99.81%, respectively. For the same conditions, in the same sequence with LNCB[®] in operation, ESP collection efficiencies were 99.43%, 99.12%, and 99.35%, respectively.

Operational Performance

Furnace exit gas temperature initially decreased by 100 °F, but eventually rose to within 10 °F of baseline conditions. The UBCL increased by approximately 28% for all tests. The most significant increase from baseline data occurred for a test with one mill out of service. A 52% increase in UBCL resulted in an efficiency loss of 0.69%.

Boiler efficiency showed very little change from baseline. The average with all mills in service increased by 0.16%. The higher post-retrofit efficiency was attributed to a decrease in dry gas loss with lower economizer gas outlet temperature (and subsequent lower air heater gas outlet temperature), offsetting UBCL and CO emission losses. Also, increased coal fineness mitigated UBCL.

Because sulfidation is the primary corrosion mechanism in substoichiometric combustion of sulfur-containing coal, H_2S levels were monitored in the boiler. After optimizing LNCB[®] operation, levels were largely at the lower detection limit. There were some higher local readings,

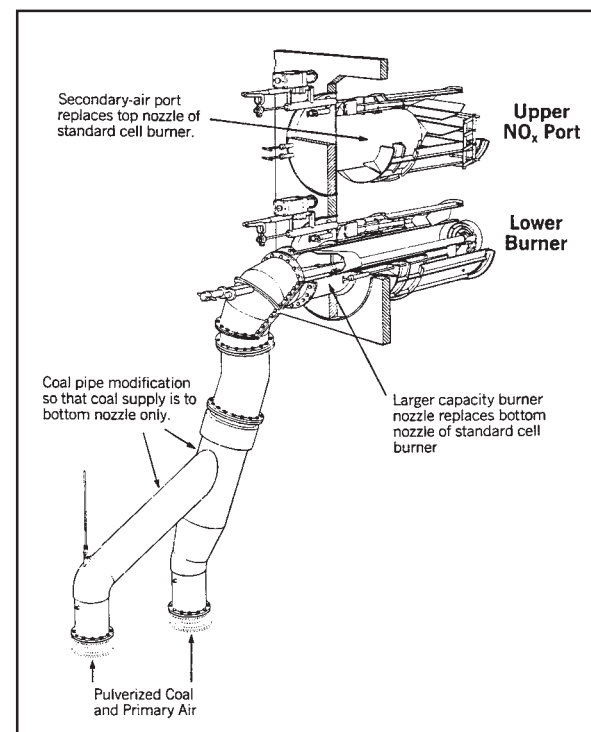

Single LNCB[®] retrofit.

but corrosion panel tests established that corrosion rates with LNCB[®] were roughly equivalent to pre-retrofit rates.

Ash sample analyses indicated that ash deposition would not be a problem. The LNCB[®] ash differed little from baseline ash. Furthermore, the small variations observed in furnace exit gas temperature between baseline and LNCB[®] indicated little change in furnace slagging. Startup and shutdown of the unit were unaffected by conversion to LNCB[®].

Economic Performance

The economic analyses were performed for a 600-MWe nominal unit size and typical location in the Midwest United States. A medium-sulfur, medium-volatile bituminous coal was chosen as the typical fuel. For a baseline NO_x emission level of 1.2 lb/10⁶ Btu, 65% capacity factor, and a 50% reduction target, the estimated capital cost was \$9/kW (1994\$). The 15-year levelized cost of elec-

tricity was estimated at 0.284 mills/kWh, or \$96.48/ton of NO_x removed in constant 1994 dollars.

Commercial Applications

The market for LNCB[®] technology is 33, two-nozzle type cell burner boilers in the U.S. (5 cell burners are three-nozzle types) with a total generating capacity of 25,200 MWe. The LNCB[®] system installed at the Dayton Power & Light Company's J.M. Stuart Plant unit No. 4 has been retained for commercial service.

Commercial success to date, and likely to come, is owed largely to the establishment of the LNCB[®] Advisory Committee composed of most of the cell burner equipped boiler owners. The Committee participated in the demonstration, becoming familiar with the technology, supporting numerical models, providing inputs to the demonstration, and reviewing field data.

The demonstration project received *R&D* magazine's 1994 R&D Award.

Contacts

Dot K. Johnson, (330) 860-1757
The Babcock & Wilcox Company
20 South Van Buren Avenue
P.O. Box 351
Barberton, OH 44203-0351
(330) 860-2348 (fax)
dkjohnson1@babcock.com

Victor K. Der, DOE/HQ, (301) 903-2700
victor.der@hq.doe.gov

Thomas A. Sarkus, NETL, (412) 386-5981
sarkus@netl.doe.gov

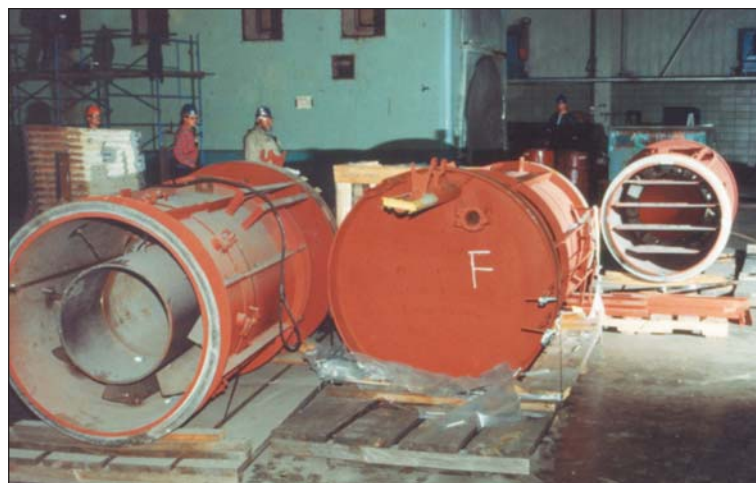

Cell burner AOFA connection with air control vanes open (right) lying next to cell burner housing showing primary air directional vanes and coal tube (left).

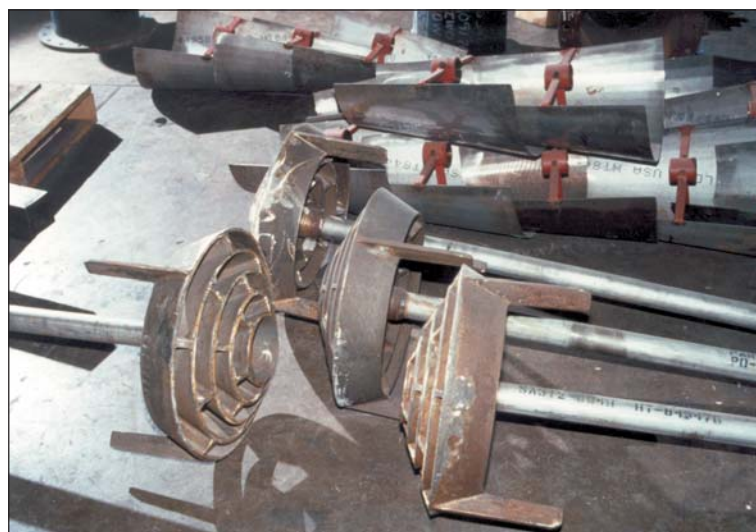

The S-Type burner impellers used in the LNCB[®] design.

References

Final Report: Full-Scale Demonstration of Low-NO_x Cell[™] Burner Retrofit. Report No. DOE/PC/90545-T2. The Babcock & Wilcox Company, Research and Development Division. December 1995. (Available from NTIS as DE96003766.)

Full-Scale Demonstration of Low-NO_x Cell Burner Retrofit: Public Design Report. Report No. DOE/PC/90545-T4. The Babcock & Wilcox Company, Energy Services Division. August 1991. (Available from NTIS as DE92009768.)

Comprehensive Report to Congress on the Clean Coal Technology Program: Full-Scale Demonstration of Low-NO_x Cell Burner Retrofit. The Babcock & Wilcox Company. Report No. DOE/FE-0197P. U.S. Department of Energy. July 1990. (Available from NTIS as DE90018026.)

Full-Scale Demonstration of Low-NO_x Cell Burner[®] Retrofit—Project Performance Summary. U.S. Department of Energy. June 1999.

Evaluation of Gas Reburning and Low-NO_x Burners on a Wall-Fired Boiler

Project completed

Participant

Energy and Environmental Research Corporation

Additional Team Members

Public Service Company of Colorado—cofunder and host

Gas Research Institute—cofunder

Colorado Interstate Gas Company—cofunder

Electric Power Research Institute—cofunder

Foster Wheeler Energy Corp.—technology supplier

Location

Denver, Adams County, CO (Public Service Company of Colorado's Cherokee Station, Unit No. 3)

Technology

Energy and Environmental Research Corporation's gas reburning (GR) system and Foster Wheeler Energy Corp.'s low-NO_x burners (LNB)

Plant Capacity/Production

172 MWe (gross), 158 MWe (net)

Coal

Colorado bituminous, 0.40% sulfur, 10% ash, 1.51% nitrogen

Project Funding

Total	\$17,807,258	100%
DOE	8,895,790	50
Participant	8,911,468	50

Project Objective

To attain up to a 70% decrease in NO_x emissions from an existing wall-fired utility boiler, firing low-sulfur coal using both gas reburning and low-NO_x burners (GR-

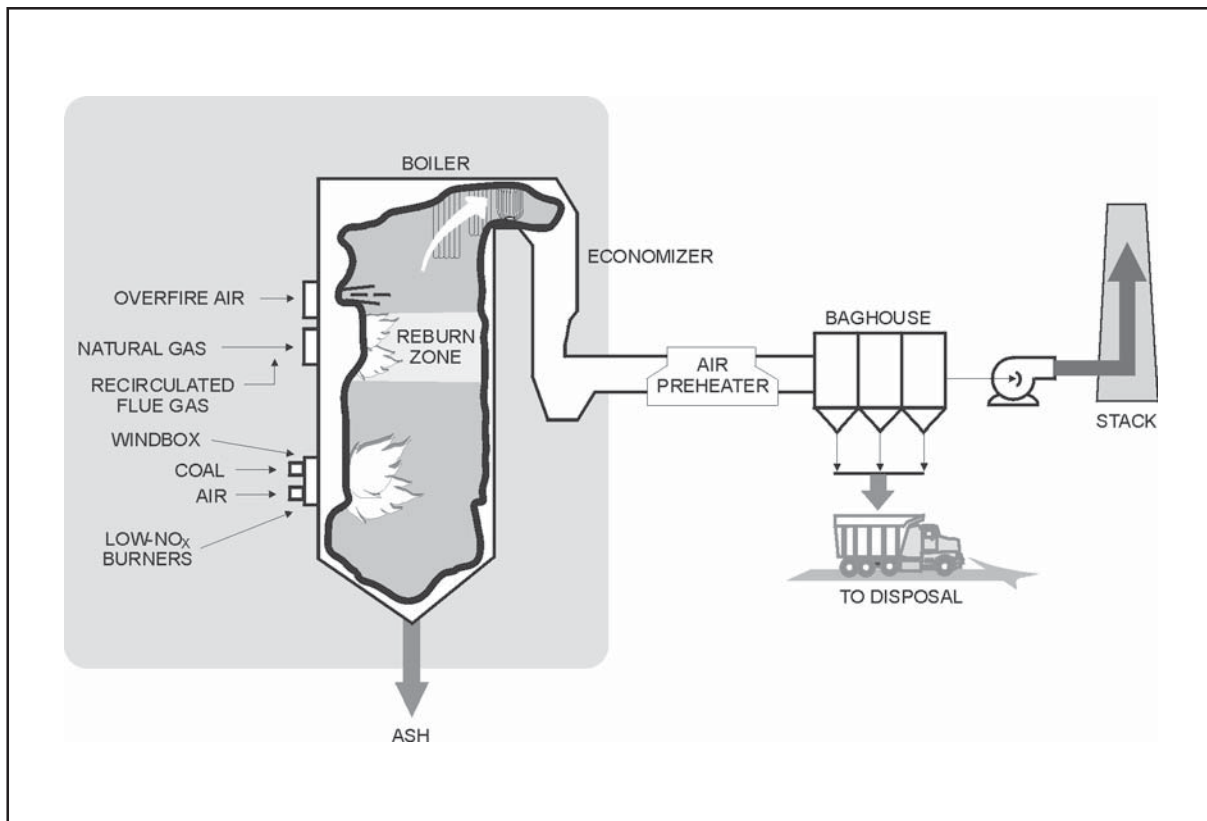

LNB); and to assess the impact of GR-LNB on boiler performance.

Technology/Project Description

Gas reburning involves injecting natural gas (up to 25% of total heat input) above the primary combustion zone in a boiler. This upper-level injection and partial combustion by limiting available oxygen creates a fuel-rich zone. NO_x moving upward from coal combustion in the lower furnace is stripped of oxygen as the reburn fuel is partially combusted in the reburn zone and converted to molecular nitrogen. Overfire air ports above the reburn zone provide for complete combustion in a relatively cool region of the boiler. Reburning allows the low-NO_x burners to operate at excess air levels far below that needed for complete combustion, thus enhancing their effectiveness. The synergistic effect of adding a reburning stage to wall-fired

boilers equipped with low-NO_x burners was intended to lower NO_x emissions by up to 70%. Gas reburning was demonstrated with and without the use of flue gas recirculation (FGR).

A series of parametric tests was performed on the gas reburning system, varying operational control parameters and assessing the effect on boiler emissions, completeness of combustion (carbon-in-ash or loss-on-ignition), thermal efficiency, and heat rate. A one-year long-term testing program was performed in order to judge the consistency of system outputs, assess the impact of long-term operation on the boiler equipment, gain experience in operating GR-LNB in a normal load-following environment, and develop a database for use in subsequent GR-LNB applications. Both first- (with FGR) and second-generation (without FGR) gas reburning tests were performed.

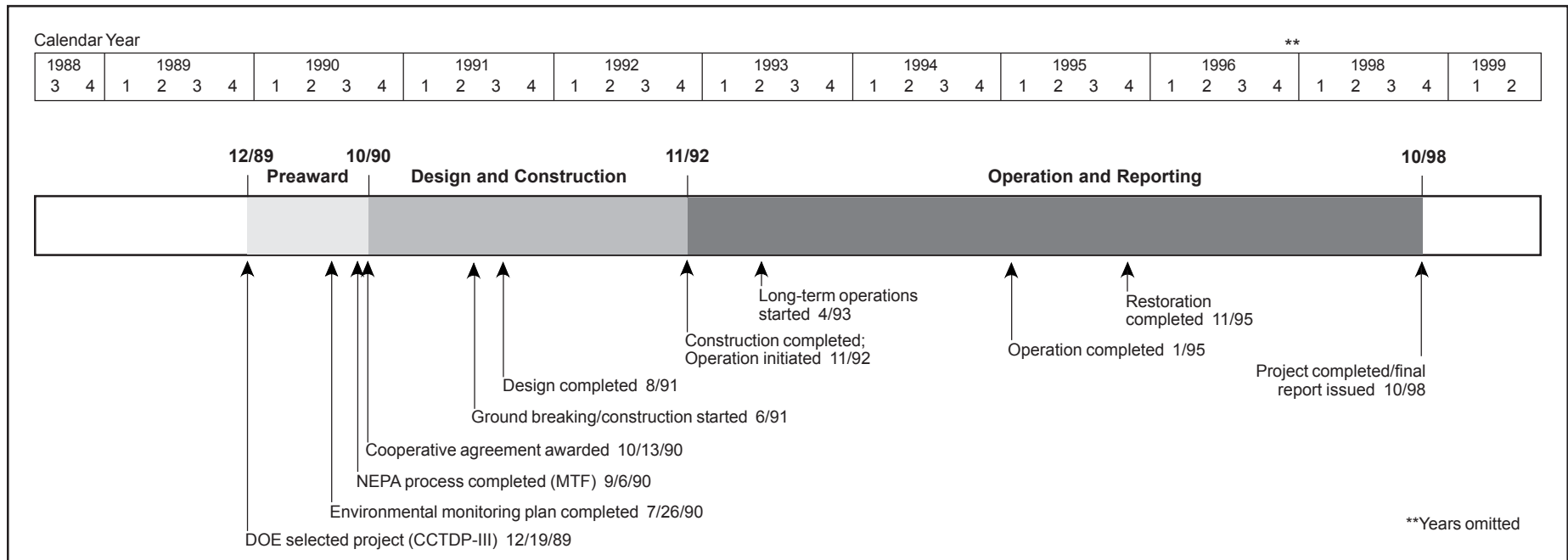

Results Summary

Environmental

- LNB alone reduced NO_x emissions from a pre-construction baseline of 0.73 lb/10⁶ Btu to 0.46 lb/10⁶ Btu (at 3.5% O₂), a 37% NO_x reduction.
- First-generation GR, which incorporated FGR in combination with LNB, reduced NO_x emissions to an average 0.25 lb/10⁶ Btu (at 3.25% O₂), a 66% NO_x reduction at an 18% gas heat input rate.
- Second-generation GR, without FGR and in combination with LNB, reduced NO_x emissions to an average 0.26 lb/10⁶ Btu, a 64% NO_x reduction with only 12.5% gas heat input.
- Both first- and second-generation GR with LNB were capable of reducing NO_x emissions by up to 70% for short periods of time, but only with higher than acceptable reburn gas heat inputs.
- The average NO_x emission reduction achieved in a dispatch mode over the longer term was approximately 64% for both first- and second-generation GR.

- After modifying the overfire air system to enhance penetration and turbulence (as part of second-generation GR), CO emissions were controlled to acceptable levels at low gas heat input rates.
- SO₂ emissions and particulate loadings were reduced by the percentage heat input supplied by GR.

Operational

- Boiler efficiency decreased by 1%.
- There was no measurable boiler tube wear and only a small amount of slagging.
- Carbon-in-ash and CO levels were acceptable for first- and second-generation GR with LNB, but not with LNB alone.

Economic

- Capital cost for a GR-LNB retrofit of a 300-MWe plant is \$26.01/kW (1996\$) plus the gas pipeline cost, if not already existing (\$12.14/kW for GR only and \$13.87/kW for LNB only).

- Operating costs were related to the gas/coal cost differential and the value of SO₂ emission allowances because GR reduces SO₂ emissions when displacing coal.

Project Summary

The demonstration established that GR-LNB offers a cost-effective option for deep NO_x reductions on wall-fired boilers. GR-LNB NO_x control performance approached that of selective catalytic reduction (SCR), but at significantly lower cost. The importance of cost-effective technology for deep NO_x reductions is that it meets the need for NO_x reduction in ozone nonattainment areas beyond what is currently projected in Title IV of the CAAA. Title I of the CAAA deals with ozone nonattainment and is currently the driving force for deep NO_x reduction in many regions of the country. Even for the more stringent levels required under Title I, GR-LNB can be used to reduce the size and cost of downstream treatment.

The GR-LNB was installed and evaluated on a 172-MWe (gross) wall-fired boiler—a Babcock & Wilcox balanced-



A worker inspects the support ring for the Foster Wheeler low-NO_x burner installed in the boiler wall.

draft pulverized coal-fired unit. The GR system, including an overfire air system, was designed and installed by Energy and Environmental Research Corporation. The LNBs were designed and installed by Foster Wheeler Energy Corp.

Parametric testing began in October 1992 and was completed in April 1993. The parametric tests examined the effect of process variables (such as zone stoichiometric ratio, percent gas heat input, percent overfire air, and load) on NO_x reduction, SO₂ reduction, CO emissions, carbon-in-ash, and heat rates. The baseline performance of the LNB was also established.

Environmental Performance

At a constant load (150 MWe) and a constant oxygen level at the boiler exit, NO_x emissions were reduced with increasing gas heat input. At gas heat inputs greater than 10%, NO_x emissions were reduced marginally as gas heat input increased. Natural gas also reduced SO₂ emissions in proportion to the gas heat input. At the Cherokee Station, low-sulfur (0.40%) coal is used, and typical SO₂ emissions are 0.65 lb/10⁶ Btu. With a gas heat input of 20%, SO₂ emissions decreased by 20% to 0.52 lb/10⁶ Btu. The CO₂ emissions were also reduced as a result of using natural gas because it has a lower carbon-to-hydrogen ratio than coal. At a gas heat input of 20%, the CO₂ emissions were reduced by 8%.

Long-term testing was initiated in April 1993 and completed in January 1995. The objectives of the test were to obtain operating data over an extended period when the unit was in routine commercial service, determine the effect of GR-LNB operation on the unit, and obtain incremental maintenance and operating costs with GR. During long-term testing, it was determined that flue gas recirculation had minimal effect on NO_x emissions.

A second series of tests was added to the demonstration to evaluate a modified or second-generation system.

Modifications included the following:

- The FGR system, originally designed to provide momentum to the natural gas, was removed. (This change significantly reduced capital costs.)
- Natural gas injection was optimized at 10% gas heat input compared to the initial design value of 18%.

- Removal of the flue gas recirculation system required installation of high-velocity injectors, which made greater use of available natural gas pressure. (This modification reduced natural gas usage and thus operating costs.)
- Overfire air ports were modified to provide higher jet momentum, particularly at low total flows.

Over 4,000 hours of operation were achieved, with the results shown in Exhibit 3-26. Although the 37% NO_x reduction performance of LNB was less than the expected 45%, the overall objectives of the demonstration were met. Boiler efficiency decreased by only 1% during gas reburning due to increased moisture in the fuel resulting from natural gas use. Further, there was no measurable tube wear, and only small amounts of slagging occurred during the GR-LNB demonstration. However, with LNB alone, carbon-in-ash and CO could not be maintained at acceptable levels.

Economic Performance

GR-LNB is a retrofit technology in which the economic benefits are dependent on the following site-specific factors:

- Gas availability at the site,
- Gas/coal cost differential,
- Boiler efficiency,

Exhibit 3-26 NO_x Data from Cherokee Station, Unit No. 3

	GR Generation	
	First	Second
Baseline (lb/10 ⁶ Btu)	0.73	0.73
Avg NO _x reduction (%)		
LNB	37	44
GR-LNB	66	64
Avg gas heat input (%)	18	12.5

- SO₂ removal requirements, and
- Value of SO₂ emission credits.

Based on the demonstration, GR-LNB is expected to achieve at least a 64% NO_x reduction with a gas heat input of 12.5%. The capital cost estimate for a 300-MWe wall-fired installation is \$26.01/kW (1996\$), plus gas pipeline costs, if required. This cost includes both equipment and installation costs and a 15% contingency. The GR and LNB system capital costs can be easily separated from one another because they are independent systems. The capital cost for the GR system only is estimated at \$12.14/kW. The LNB system capital cost is \$13.87/kW.

Operating costs are almost entirely related to the differential cost of natural gas and coal and reduced by the value of the SO₂ emission credits received due to absence of sulfur in the gas. A fuel differential of \$1.00/10⁶ Btu was used because gas costs more than coal on a heating value basis. Boiler efficiency was estimated to decline by 0.80%; the cost of this decline was calculated using a composite fuel cost of \$1.67/10⁶ Btu. Overfire air booster and cooling fan auxiliary loads will be partially offset by lower loads on the pulverizers. No additional operating labor is required, but there is an increase in maintenance costs. Allowances also were made for overhead, taxes, and insurance. Based on these assumptions and assuming an SO₂ credit allowance of \$95/ton (Feb. 1996\$), the net operating cost is \$2.14 million per year and the NO_x removal cost is \$786/ton (constant 1996\$).

Commercial Applications

The technology can be used in retrofit, repowering, or greenfield installations of wall-fired boilers. There is no known limit to the size or scope of the application of this technology combination. GR-LNB is expected to be less capital intensive, or less costly, than selective catalytic reduction. GR-LNB functions equally well with any kind of coal.

Public Service Company of Colorado, the host utility, decided to retain the low-NO_x burners and the gas-reburning system for immediate use; however, a restoration was required to remove the flue gas recirculation system.

This demonstration project was one of two that received the Air and Waste Management Association's 1997 J. Deane Sensenbaugh Award.

Contacts

Blair A. Folsom, Sr., V.P., (949) 859-8851, ext. 140
 General Electric Energy and Environmental
 Research Corporation
 18 Mason
 Irvine CA 92618
 blair.folsom@ps.ge.com
 (949) 859-3194 (fax)

Victor K. Der, DOE/HQ, (301) 903-2700
 victor.der@hq.doe.gov

Thomas A. Sarkus, NETL, (412) 386-5981
 sarkus@netl.doe.gov

References

Evaluation of Gas Reburning and Low-NO_x Burners on a Wall-Fired Boiler: Performance and Economics Report, Gas Reburning—Low-NO_x Burner System, Cherokee Station Unit No. 3, Public Service Company of Colorado. Final Report. July 1998.

Guideline Manual: Gas Reburning—Low-NO_x Burner System, Cherokee Station Unit No. 3. Public Service Company of Colorado. Final Report. July 1998.

Evaluation of Gas Reburning and Low-NO_x Burners on a Wall-Fired Boiler (Long-Term Testing, April 1993–January 1995). Report No. DOE/PC/90547-T20. Energy and Environmental Research Corporation. June 1995. (Available from NTIS as DE95017755.)

Evaluation of Gas Reburning and Low-NO_x Burners on a Wall-Fired Boiler (Optimization Testing, November 1992–April 1993). Report No. DOE/PC/90547-T19. Energy and Environmental Research Corporation. June 1995. (Available from NTIS as DE95017754.)

Evaluation of Gas Reburning and Low-NO_x Burners on a Wall-Fired Boiler—Project Performance Summary. U.S. Department of Energy. October 2001.

Micronized Coal Reburning Demonstration for NO_x Control

Project completed

Participant

New York State Electric & Gas Corporation (NYSEG)

Additional Team Members

Eastman Kodak Company—host and cofunder

CONSOL (formerly Consolidation Coal Company)—coal sample tester

DB Riley—technology supplier

Fuller Company—technology supplier

Energy and Environmental Research Corporation (EER)—reburn system designer

New York State Energy Research and Development Authority—cofunder

Empire State Electric Energy Research Corporation—cofunder

Locations

Lansing, Tompkins County, NY (NYSEG's Milliken Station, Unit No. 1). This station is currently owned by AES Corporation and is designated AES Cayuga.

Rochester, Monroe County, NY (Eastman Kodak Company's Kodak Park Power Plant, Unit No. 15)

Technology

Micronized coal reburning using DB Riley's MPS mill (at Milliken Station) and Fuller's MicroMill™ (at Eastman Kodak) technologies for producing micronized coal

Plant Capacity/Production

Milliken Station: 148-MWe tangentially fired boiler

Kodak Park: 60-MWe cyclone boiler

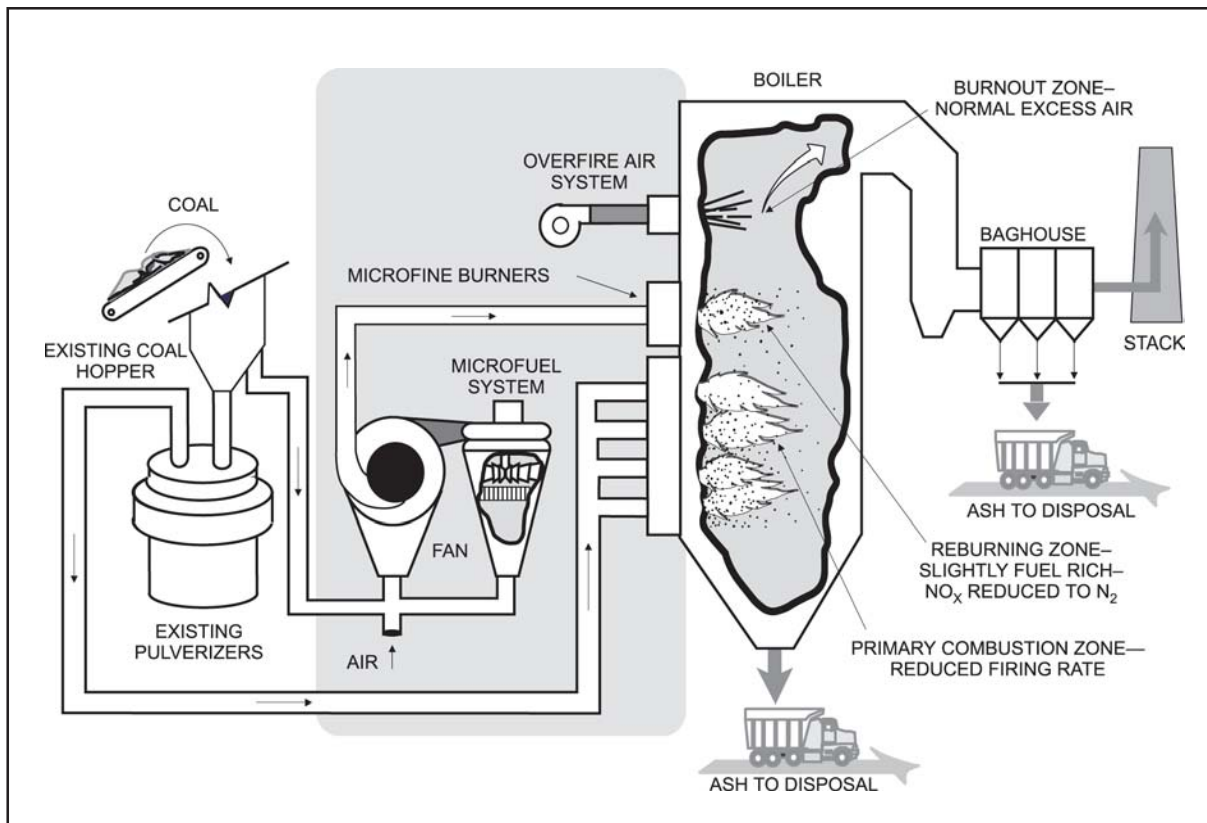

Coal

Pittsburgh seam bituminous, medium- to high-sulfur (3.2% sulfur and 1.5% nitrogen at Milliken and 2.2% sulfur and 1.6% nitrogen at Kodak Park)

Project Funding

Total	\$9,096,486	100%
DOE	2,701,011	30
Participant	6,395,475	70

Project Objective

To achieve at least 50% NO_x reduction with micronized coal reburning technology on a cyclone boiler, to achieve 25–35% NO_x reduction with micronized coal reburning technology in conjunction with low-NO_x burners on a tangentially fired boiler, and to determine the effects of coal micronization on electrostatic precipitator (ESP) performance.

Technology/Project Description

The reburn coal, which can constitute up to 30% of the total fuel, is micronized (pulverized to achieve 80% below 325 mesh) and injected into a pulverized coal-fired furnace above the primary combustion zone. At the Milliken tangentially fired boiler site, NO_x control is achieved by: (1) close-coupled overfire air (CCOFA) reburning in which the top coal injector of the LNCFS III™ burner is used for injecting the micronized coal, and the separated overfire air system completes combustion; and (2) the remaining burners and air ports are adjusted for deep-staged combustion by re-aiming them to create a fuel-rich inner zone and fuel-lean outer zone providing combustion air. At the Kodak Park cyclone boiler site, the Fuller MicroMill™ is used to produce the micronized coal, reburn fuel is introduced above the cyclone combustor, and overfire air is employed to complete the combustion.

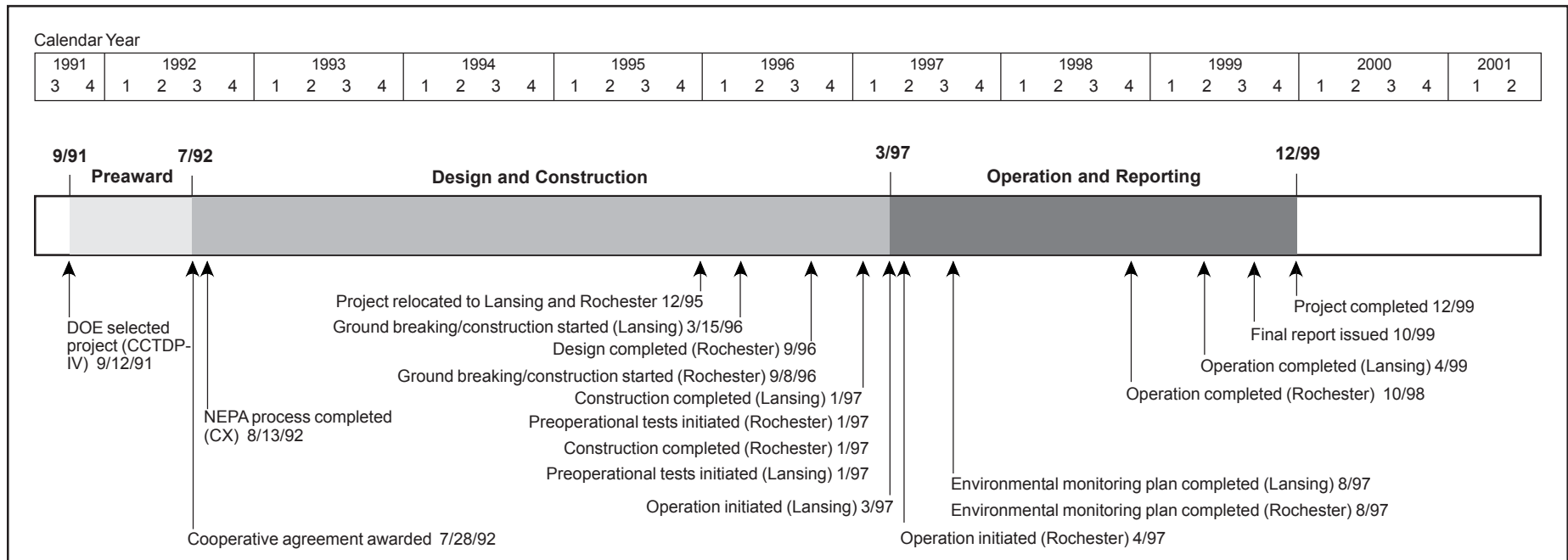

Results Summary

Environmental

- Using a 14.4% reburn fuel heat input on the Milliken Station tangentially fired boiler at full load resulted in a NO_x emission rate of 0.25 lb/10⁶ Btu, which represents a 29% NO_x reduction from the 0.35 lb/10⁶ Btu achieved with the LNCFS III™ burner alone (baseline).
- Using a 17.3% reburn fuel heat input (reburn stoichiometry of 0.89) on the Kodak Park cyclone boiler resulted in a NO_x emission rate of 0.59 lb/10⁶ Btu, which represents a 59% NO_x reduction from 1.36 lb/10⁶ Btu (baseline). Higher reburn rates (estimated at 18.4% reburn or stoichiometry of 0.87) would be required for long-term compliance with 0.60 lb/10⁶ Btu NO_x emission limits.

Operational

- Reburning was successfully applied at Milliken Station using the top coal injector of the LNCFS III™ burner for the reburn fuel and reducing the top burner level air flows. This eliminated the need for a separate

reburn system. Testing on the tangentially fired boiler at Milliken Station showed:

- Unburned carbon in ash, also referred to as loss-on-ignition (LOI), was maintained under 5%;
 - Increasing the economizer O₂ generated the classical response of higher NO_x emissions and lower LOI—the sensitivity was estimated at 0.1 lb/10⁶ Btu per 1% change in O₂ and was relatively independent of coal fineness;
 - Increasing coal fineness reduced both NO_x emissions and LOI—the effect on NO_x was significant only for large variations in coal fineness; and
 - Pulverizing the reburn coal to the micronized level (greater than 80% passing 325 mesh) was not a requirement for the successful application of reburning, but significantly impacted LOI.
- Testing on the cyclone boiler at Kodak Park showed:
 - The reburn stoichiometry had a significant effect on both NO_x emissions and LOI—lower reburn stoichiometries reduced NO_x emissions and increased LOI to 40–45% compared with a LOI baseline of 10–15%.

- Short-term testing indicated that LOI could be maintained at levels similar to baseline levels without significantly affecting NO_x emissions by maintaining a baseline cyclone heat input.

Economic

- The estimated capital cost for retrofitting a generic 300-MWe tangentially fired boiler with micronized coal reburning is \$4.3 million, or approximately \$14/kW (1999\$). The corresponding O&M costs are estimated at \$0.30 million per year (1999\$). The resulting total 15-year levelized cost is \$1,329/ton of NO_x removed (current 1999\$) or \$1,023 (constant 1999\$).
- The estimated capital cost for retrofitting a generic 300-MWe cyclone boiler with micronized coal reburning is \$16.9 million, or approximately \$56/kW (1999\$). The corresponding O&M costs are estimated at \$0.80 million per year (1999\$). The total 15-year levelized cost is \$741/ton of NO_x removed (current 1999\$) or \$571/ton (constant 1999\$).

Project Summary

NYSEG demonstrated the micronized coal reburning technology in both tangentially fired and cyclone boilers. The tangentially fired boiler was NYSEG's Milliken Station 148-MWe tangentially fired Unit No. 1 (also the host for another CCT Program demonstration). The cyclone boiler was Eastman Kodak Company's Kodak Park Power Plant 60-MWe cyclone Unit No. 15.

The challenge with this coal reburning demonstration was to achieve adequate combustion of the reburn coal in the oxygen-deficient, short-residence-time reburn zone to reduce NO_x emissions without detrimentally increasing the unburned carbon in the ash, *i.e.*, loss-on-ignition. The primary objective of this two-site project was to demonstrate improvements in coal reburning for NO_x emission control by reducing the particle size of the reburn coal. In this demonstration, the coal was finely ground to 80% or more passing 325 mesh and injected into the boilers above the primary combustion zone. The resulting typical particle size is 20 microns compared to 60 microns for normal pulverized coal particles. This smaller size increases surface area ninefold.

With this increased surface area and coal fineness (micronized coal has the combustion characteristics of atomized oil), carbon combustion occurs in milliseconds and volatiles are released at an even rate.

Operating Performance

At the Milliken Station, the existing ABB Low-NO_x Concentric Firing System™ (LNCFS-III), which includes both CCOFA and separated overfire air (SOFA) ports, was used for the reburn demonstration. Four DB Riley MPS 150 mills with dynamic classifiers provided the pulverized coal. With LNCFS-III, there are four levels of burners. To simulate and test the coal reburning application, the top-level coal injection nozzles fed micronized coal to the upper part of the furnace for this demonstration. The coal injection nozzles at the three lower elevations were biased to carry approximately 80% of the fuel required for full load. The speed of the dynamic classifier serving the mill feeding the top burners was increased to produce the micronized coal (greater than 80% passing 325 mesh).

During the evaluation, several conclusions were reached on how operating variables affected performance. While maintaining a constant economizer O₂ level, no single operating variable had a dominant effect on reburning performance. A combination of operating settings determined from short-term testing were selected for long-term operation to achieve the lowest NO_x emissions and reliable operation. Operating settings for long-term operation were 14–16% reburn coal, 105 rpm top mill classifier speed (corresponds to 70–72% passing 325 mesh), –5 degrees main burner tilt and 2.8% economizer O₂. No additional improvement in LOI was observed at top mill classifier speeds above 105 rpm.

At Kodak Park, EER designed the micronized coal reburn system using a combination of analytical and empirical techniques. The reburn fuel and overfire air (OFA) injection components were designed with a high degree of flexibility to allow for field optimization to accommodate the complex furnace flow patterns in the cyclone boiler. Two Fuller MicroMills™ were installed in parallel on Kodak Park Unit No. 15 to provide the capacity necessary for high reburn rates, with the second mill serving as a spare at lower reburn rates. The mills produced the micronized coal reburn fuel at greater than 90% passing 325 mesh. Eight injectors, six on the rear wall and one on each of the side walls, introduced the micronized coal into the reburn zone. The optimization variables included the number of injectors, swirl, and velocity. Four ports on the front wall provided OFA using EER's second-generation, dual-concentric overfire air design, which has variable injection velocity and swirl. To maximize NO_x reduction, the reburn fuel was injected with flue gas rather than air. The flue gas was extracted downstream of the electrostatic precipitator and was boosted by a single fan. A new boiler control system was also installed on Unit No. 15.

Environmental Performance

At the Milliken Station, micronized coal reburning with 14.4% reburn fuel at full load reduced NO_x emissions from the 0.35 lb/10⁶ Btu baseline level to 0.25 lb/10⁶ Btu, a 29% reduction. This reduction represents an addition to the 39% reduction achieved with the LNCFS III™ low-NO_x burner alone. Boiler efficiency was maintained at 88.4–88.8%. Furthermore, concentrating the overfire air through fewer

and higher ports and using finer grind reburn coal maintained LOI below 5%. Based on long-term testing consisting of 23 days of continuous measurements, the achievable annual NO_x emissions using 15.1% coal reburn heat input were estimated at 0.245 ± 0.011 lb/10⁶ Btu (95% confidence), and the estimated average fly ash LOI was 4.4 ± 0.4%. Based on replicated performance tests and a 95% confidence level, variations in NO_x emissions less than 0.006 lb/10⁶ Btu and in fly ash LOI less than 1.5 percentage points were assumed to be of no statistical significance. There were large uncertainties with respect to the effects on LOI, possibly because LOI generally varied within a relatively narrow range (between 3% and 5%) in response to changing operating variables.

With regard to reburn coal fineness and reburn coal quantity, using a finer grind reburn coal (top mill) reduced both NO_x emissions and LOI. The effect on NO_x was significant (relative to the uncertainty level of 0.006 lb/10⁶ Btu) only for relatively large variations in the top mill classifier speed (and hence coal fineness). Using a finer grind coal (all mills) reduced both NO_x emissions and LOI. Decreasing the reburn coal fraction from 25% to 14% decreased NO_x emissions from 0.25 to 0.23 lb/10⁶ Btu and had a minor effect on LOI (generally less than 1.5 percentage points). The decrease in NO_x from decreasing the coal reburn fraction was attributed to lower excess air levels in the primary combustion zone as more coal was diverted to the lower burners.

Reducing the boiler load reduced NO_x emissions, and the effect was greater when the second mill was taken out of service. Thus, reducing the boiler load by taking the second mill out of service is a recommended option. Taking the second mill out of service while maintaining the same boiler load reduced NO_x emissions at both high (140 MW) and low (110 MW) boiler loads, possibly due to longer residence times in the primary combustion zone.

Changes in air flow resulted in measurable changes in both NO_x reduction and LOI. An increase in the reburn coal transport air (top burner primary air), corresponding to a 20% increase in the air-to-fuel ratio from 2.05 to 2.45, increased NO_x emissions from 0.28 lb/10⁶ Btu to 0.31 lb/10⁶ Btu. This increase in NO_x was attributed to less reducing reburn zones with the additional introduction of an oxidant with the

reburn fuel. Increasing the top level auxiliary airflow increased both NO_x emissions and LOI. This increase in NO_x was attributed to less reducing reburn zones as more oxidant was introduced through the auxiliary air nozzle situated directly below the reburn coal nozzle. The increase in LOI from increasing the top level auxiliary airflow was attributed to lower excess air levels in the primary combustion zone as more air was diverted away from the lower burners. Increasing the economizer O_2 generated the classical response of higher NO_x emissions and lower or stable LOI. The economizer O_2 sensitivity was estimated at 0.1 lb $\text{NO}_x/10^6$ Btu per 1% change in O_2 and was relatively independent of the reburn coal fineness.

The SOFA and main burner tilts had minimal effects on performance. Variations in the SOFA tilt between 0 and 15 degrees (above horizontal) had minor effects on both NO_x emissions and LOI in both LNCFS III™ and reburn configurations. Operating the main burner tilt slightly below the horizontal (about -5 degrees) improved the reburning performance (lower LOI without increasing NO_x), relative to the horizontal setting, which was attributed to longer residence times in the furnace prior to overfire air introduction. Overall, the effect was difficult to quantify due to the limited number of tests.

At Kodak Park, the application of micronized coal reburning reduced NO_x emissions and increased LOI, as expected. Micronized coal reburning with 17.3% reburn fuel at a reburn stoichiometry of 0.89 reduced NO_x emissions to 0.59 lb/ 10^6 Btu from a baseline of 1.36 lb/ 10^6 Btu, a 59% reduction, and reduced the boiler efficiency from 87.8% to 87.3%. At greater reburn rates, further NO_x reduction was achieved to a degree comparable with gas reburning systems. At full load, LOI was 40–45%, compared with a baseline level of 10–12%.

Based on long-term testing, the achievable annual NO_x emissions (at 15.6% reburn or stoichiometry of 0.90) were 0.69 ± 0.03 lb/ 10^6 Btu (95% confidence), corresponding to an LOI of $38\% \pm 2\%$. Higher reburn feeds (estimated at 18.4% reburn or stoichiometry of 0.87) would be required for long-term compliance with the 0.6 lb/ 10^6 Btu NO_x emissions limit.

The reburn stoichiometry had a significant effect on NO_x emissions and a significant effect on the LOI. Lower reburn stoichiometries reduced NO_x emissions and increased the LOI, typically dropping below 0.6 lb/ 10^6 Btu at reburn stoichiometries below 0.9 and corresponding to 40–45% LOI. The increase in the LOI relative to baseline was partially due to a lower cyclone heat input, which resulted in lower temperatures in the primary combustion zone. The lower temperatures produced less thermal NO_x formation and less efficient char burnout. The LOI increase was also partially due to the staged combustion resulting in shorter residence times under oxidizing conditions. At constant heat input levels, the LOI was not significantly different with or without reburning, suggesting that in reburn applications, the LOI could be maintained at levels similar to baseline by maintaining a high cyclone heat input. The contribution of reburning alone (assuming no change in the cyclone heat input) to the increase in the LOI was estimated at 0–12% (absolute).

Economic Performance

Estimates were prepared for retrofitting micronized coal reburning on generic 300-MWe tangentially fired and cyclone boilers. For the tangentially fired boiler, the capital costs were estimated at \$4.3 million, or approximately \$14/kW (1999\$). The O&M costs were estimated at \$0.30 million per year (1999\$). Costs were levelized both on a current dollar and constant dollar basis. The 15-year levelized cost for the 300-MWe unit is \$1,329/ton of NO_x removed on a current dollar basis, and \$1,023/ton of NO_x removed on a constant dollar basis (1999\$).

For the cyclone boiler, the estimated capital cost is \$16.9 million, or approximately \$56/kW (1999\$). The estimated O&M costs are \$0.80 million per year (1999\$). The total 15-year levelized cost is \$741/ton of NO_x removed on a current dollar basis or \$571 on a constant dollar basis (1999\$).

Commercial Applications

Micronized coal reburning technology can be applied to existing and greenfield cyclone-fired, wall-fired, and tangentially fired pulverized coal units. The technology reduces NO_x emissions by 20–59% with minimal furnace modifications for existing units.

The availability of a coal-reburning fuel, as an additional fuel to the furnace, enables switching to lower heating-value coals without boiler derating. Commercial units can achieve a turndown of 8:1 on nights and weekends without consuming expensive auxiliary fuel.

Contacts

Jim Harvilla, (607) 762-8630
New York State Electric & Gas Corporation
Corporate Drive—Kirkwood Industrial Park
P.O. Box 5224
Binghamton, NY 13902-5224
jjharvilla@nyseg.com
(607) 762-4002 (fax)

Victor K. Der, DOE/HQ, (301) 903-2700
victor.der@hq.doe.gov

Thomas A. Sarkus, NETL, (412) 386-5981
sarkus@netl.doe.gov

References

Micronized Coal Reburning Demonstration for NO_x Control. Final Report. New York State Electric & Gas Corporation and CONSOL, Inc. October 1999.

Reburning Technologies for the Control of Nitrogen Oxides from Coal-Fired Boilers. U.S. Department of Energy, Babcock & Wilcox, EER Corp., and NYSEG. Topical Report No. 14. May 1999.

“Micronized Coal Reburning Demonstration of NO_x Control.” *Sixth Clean Coal Technology Conference: Technical Papers.* Savichky et al. April–May 1998.

Demonstration of Selective Catalytic Reduction Technology for the Control of NO_x Emissions from High-Sulfur, Coal-Fired Boilers

Project completed

Participant

Southern Company Services, Inc.

Additional Team Members

Electric Power Research Institute—cofunder

Ontario Hydro—cofunder

Gulf Power Company—host

Location

Pensacola, Escambia County, FL (Gulf Power Company's Plant Crist, Unit No. 5)

Technology

Selective catalytic reduction (SCR)

Plant Capacity/Production

8.7-MWe equivalent (three 2.5-MWe and six 0.2-MWe equivalent SCR reactor plants)

Coal

Illinois bituminous, 2.7% sulfur

Project Funding

Total	\$23,229,729	100%
DOE	9,406,673	40
Participant	13,823,056	60

Project Objective

To evaluate the performance of commercially available SCR catalysts when applied to operating conditions found in U.S. pulverized coal-fired utility boilers using high-

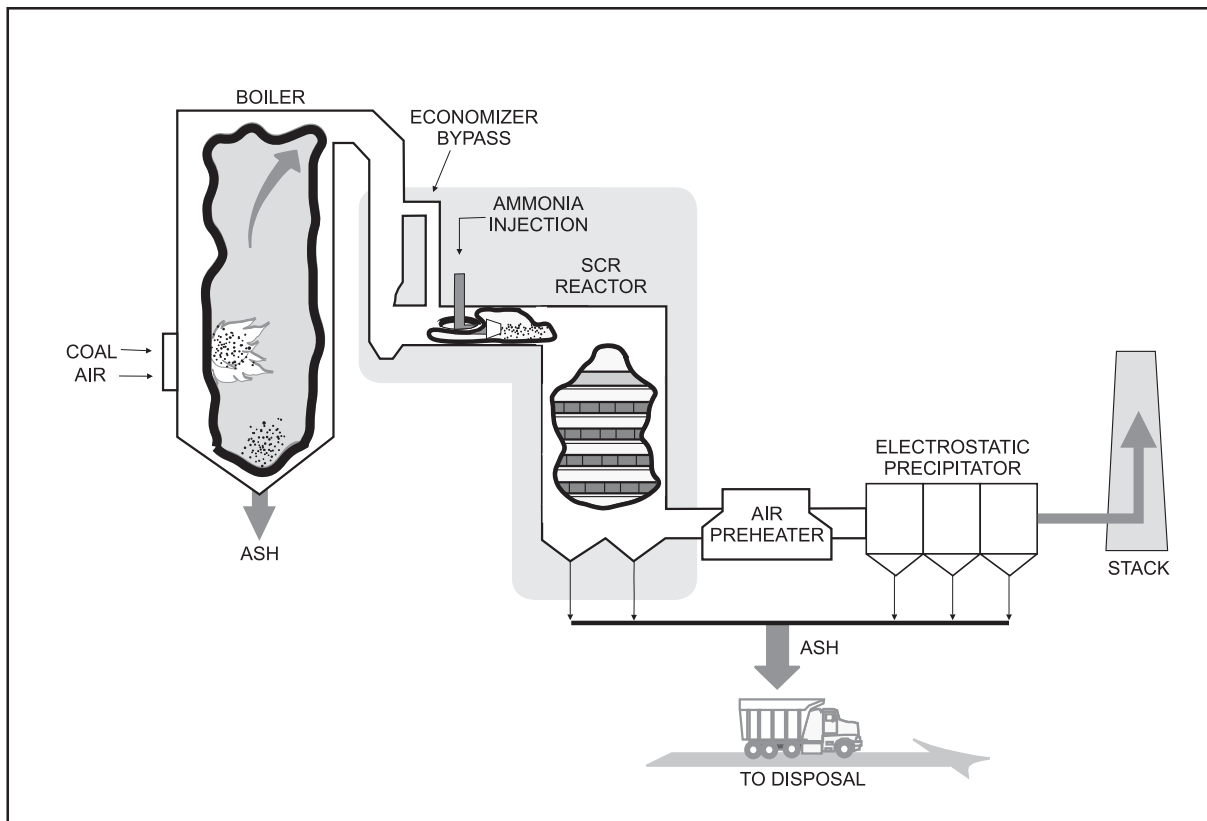

sulfur U.S. coal under various operating conditions, while achieving as much as 80% NO_x removal.

Technology/Project Description

The SCR technology consists of injecting ammonia into boiler flue gas and passing it through a catalyst bed where the NO_x and ammonia react to form nitrogen and water vapor.

In this demonstration project, the SCR facility consisted of three 2.5-MWe equivalent SCR reactors, supplied by separate 5,000-scfm flue gas slipstreams, and six 0.20-MWe equivalent SCR reactors. These reactors were calculated to be large enough to produce design data that will allow the SCR process to be scaled up to commercial size. Catalyst suppliers (two U.S., two European, and two Japanese) provided eight catalysts with various shapes and chemical compositions for evaluation of process chemistry and economics of operation during the demonstration.

The project demonstrated, at high- and low-dust loadings of flue gas, the applicability of SCR technology to provide a cost-effective means of reducing NO_x emissions from power plants burning high-sulfur U.S. coal.

The demonstration plant, which was located at Gulf Power Company's Plant Crist near Pensacola, Florida, used flue gas from the burning of 2.7% sulfur coal.

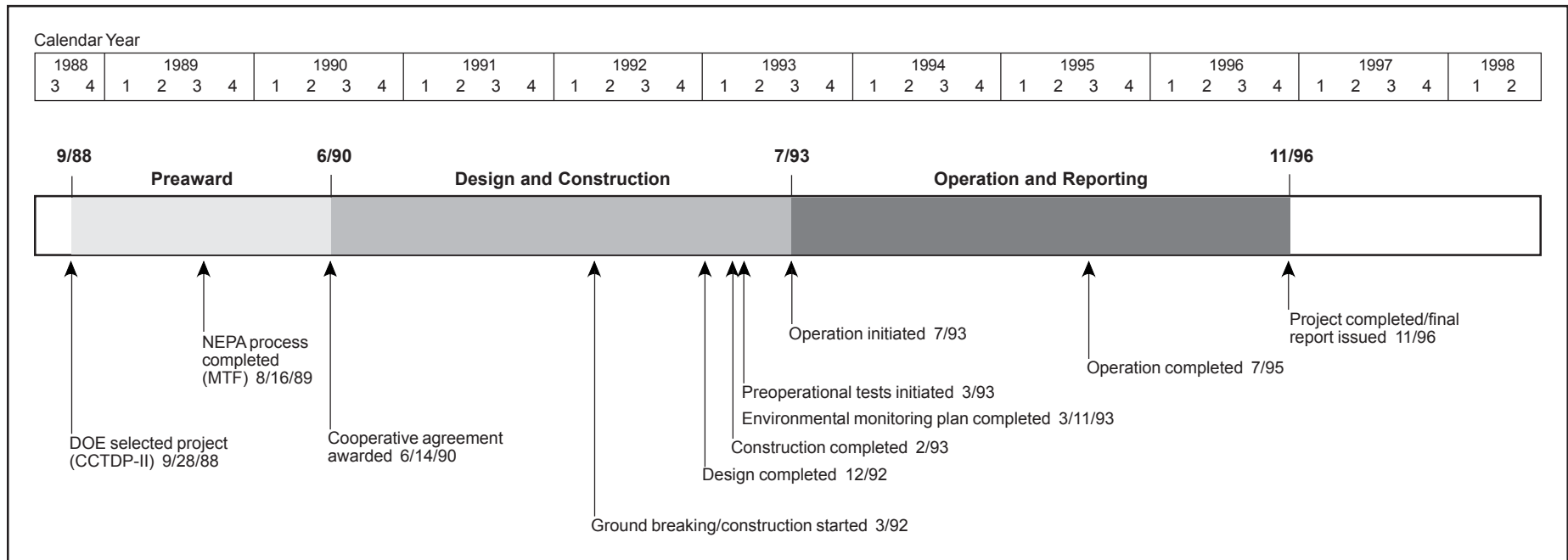

Results Summary

Environmental

- NO_x reductions of over 80 percent were achieved at an ammonia slip well under the 5 ppm deemed acceptable for commercial operation.
- For most catalysts, flow rates could be increased to 150 percent of design without exceeding the ammonia slip design level of 5 ppm at 80 percent NO_x reduction.
- While catalyst performance increased above 700 °F, the benefit did not outweigh the heat rate penalties.
- Ammonia slip, a sign of catalyst deactivation, went from less than 1 ppm to approximately 3 ppm over the nearly 12,000 hours of operation, thus demonstrating that deactivation in coal-fired units was in line with worldwide experience.
- Long-term testing showed that SO₂ oxidation was within or below the design limits necessary to protect downstream equipment.

Operational

- Fouling of catalysts was controlled by adequate sootblowing procedures.
- Long-term testing showed that catalyst erosion was not a problem once sootblowing procedures were adopted.
- Air preheater performance was degraded because of ammonia slip and subsequent by-product formation; however, solutions were identified.
- The SCR process did not significantly affect the results of Toxicity Characteristic Leaching Procedure (TCLP) analysis of the fly ash.

Economic

- Levelized costs on a 30-year basis for a 250-MWe unit, with a SCR inlet NO_x concentration of 0.35 lb/10⁶ Btu, were 2.39, 2.57, and 2.79 mills/kWh (constant 1996\$) for 40, 60, and 80 percent removal efficiency, respectively, which equates to 3,502; 2,500; and 2,036 \$/ton (constant 1996\$), respectively.

Project Summary

The demonstration tests were designed to address several uncertainties, including potential catalyst deactivation due to poisoning by trace metals species in U.S. coals, performance of the technology and its effects on the balance-of-plant equipment in the presence of high amounts of SO₂ and SO₃, and performance of the SCR catalyst under typical U.S. high-sulfur coal-fired utility operating conditions. Catalyst suppliers were required to design the catalyst baskets to match predetermined reactor dimensions, provide a maximum of four catalyst layers, and meet the conditions shown in Exhibit 3-27.

The catalysts tested are listed in Exhibit 3-28. Catalyst suppliers were given great latitude in providing the amount of catalyst for this demonstration.

Environmental Performance

Ammonia slip, the controlling factor in the long-term operation of commercial SCR, was usually <5 ppm because of plant and operational considerations. Ammonia slip was dependent on catalyst exposure time, flow rate, temperature, NH₃/NO_x distribution, and NH₃/NO_x ratio (NO_x reduction). Changes in NH₃/NO_x ratio and consequently NO_x reduction generally produced the most significant changes in ammonia slip. The ammonia slip at 60% NO_x reduction was at or near the detection limit of 1 ppm. As NO_x reduction was increased above 80%, am-

monia slip also increased and remained at reasonable levels up to NO_x reductions of 90%. Over 90%, the ammonia slip levels increased dramatically.

The flow rate and temperature effects on NO_x reduction were also measured. In general, flows could be increased to 150% of design without the ammonia slip exceeding 5 ppm, at 80% NO_x reduction and at the design temperature. With respect to temperature, most catalysts exhibited fairly significant improvements in overall performance as temperatures increased from 620 °F to 700 °F, but relatively little improvement as temperature increased from 700 °F to 750 °F. The conclusion was that the benefits of high-temperature operation probably do not outweigh the heat rate penalties involved in operating SCR at the higher temperatures.

Catalyst deactivation was observed by an increase in ammonia slip over time, assuming the NO_x reduction efficiency was held constant. Over the 12,000 hours of the demonstration tests, the ammonia slip did increase from less than 1 ppm to approximately 3 ppm. These results demonstrated the maturity of catalyst design and that deactivation was in line with prior worldwide experience.

Experience has shown that the catalytic active species that result in NO_x reduction often contributed to SO₂ oxidation

(*i.e.*, SO₃ formation), which can be detrimental to downstream equipment. In general, NO_x reduction can be increased as the tolerance for SO₃ is also increased. The upper bound for SO₂ oxidation for the demonstration catalyst was set at 0.75% at baseline conditions. The average SO₂ oxidation rate for each of the catalysts is shown in Exhibit 3-29. These data reflect baseline conditions over the life of the demonstration. All of the catalysts were within design limits, with most exhibiting oxidation rates below the design limit.

Other factors affecting SO₂ oxidations were flow rate and temperature. Most of the catalysts exhibited fairly constant SO₂ oxidation with respect to flow rate (*i.e.*, space velocity). In theory, SO₂ oxidation should be inversely proportional to flow rate. Theoretically, the relationship between SO₂ oxidation and temperature should be exponential as temperature increases; however, measurements showed the relationship to be linear with little difference in SO₂ oxidation between 620 °F and 700 °F. On the other hand, between 700 °F and 750 °F, the SO₂ oxidation increased more significantly.

Other findings from the demonstration deal with pressure drop, fouling, erosion, air preheater performance, ammo-

Parameter	Minimum	Baseline	Maximum
Temperature (°F)	620	700	750
NH ₃ /NO _x molar ratio	0.6	0.8	1.0
Space velocity (% design flow)	60	100	150
Flow rate			
Large reactor (scfm)	3,000	5,000	7,500
Small reactor (scfm)	240	400	600

Catalyst	Reactor Size*	Catalyst Configuration
Nippon/Shokubai	Large	Honeycomb
Siemens AG	Large	Plate
W.R. Grace/Noxeram	Large	Honeycomb
W.R. Grace/Synox	Small	Honeycomb
Haldor Topsoe	Small	Plate
Hitachi/Zosen	Small	Plate
Cormetech/High dust	Small	Honeycomb
Cormetech/Low dust	Small	Honeycomb

* Large = 2.5 MWe; 5,000 scfm Small = 0.2 MWe; 400 scfm

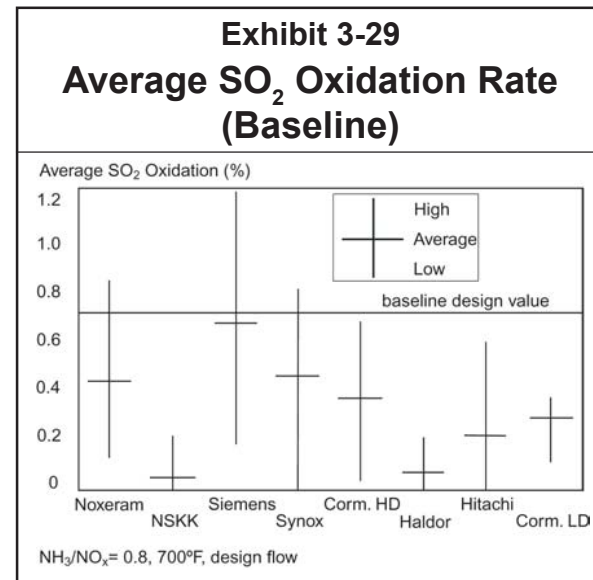

nia volatilization, and TCLP analysis. Overall reactor pressure drop was a function of the catalyst geometry and volume, but tests were inconclusive in determining which parameter was controlling. The fouling characteristics of the catalyst were important to long-term operation. During the demonstration, measurements showed a relatively level pressure drop over time, indicating that sootblowing procedures were effective. The plate-type configuration had somewhat less fouling potential than did the honeycomb configuration, but both were acceptable. Catalyst erosion was not considered to be a significant problem because most of the erosion was attributed to aggressive sootblowing. With regard to air preheater performance, the demonstration showed that the SCR process exacerbated performance degradation of the air preheaters, mainly due to ammonia slip and subsequent by-product formation. Regenerator-type air heaters outperformed recuperators in SCR applications in terms of both thermal performance and fouling. The ammonia volatilized from the SCR fly ash when a significant amount of water was absorbed by the ash. This was caused by formation of a moist layer on the ash with a pH high enough to convert ammonia compounds in the ash to gas-phase ammonia. TCLP analyses were performed on fly ash samples. The

Exhibit 3-30 SCR Design Criteria for Economic Evaluation	
Parameter	Specification
Type of SCR	Hot side
Number of reactors	One
Reactor configuration	3 catalyst support layers
Initial catalyst load	2 of 3 layers loaded
Range of operation	35–100% boiler load
NO _x inlet concentration	0.35 lb/10 ⁶ Btu
Design NO _x reduction	60%
Design ammonia slip	5 ppm
Catalyst life	16,000 hr
Ammonia cost	\$250/ton
SCR catalyst cost	\$400/ft ³

SCR process did not significantly affect the toxics leachability of the fly ash.

Economic Performance

An economic evaluation was performed for full-scale applications of SCR technology to a new 250-MWe pulverized coal-fired plant located in a rural area with minimal space limitations. The fuel considered was high-sulfur Illinois No. 6 coal. Other key base case design criteria are shown in Exhibit 3-30.

The economic analysis of capital, operating and maintenance (O&M), and levelized cost for various unit sizes for an SCR system are shown in Exhibit 3-31. Results of the economic analysis of capital, O&M, and levelized

Exhibit 3-31 SCR Economics by Unit Size			
	125 MWe	250 MWe	700 MWe
Capital cost (\$/kW)	61	54	45
Operating cost (\$/yr)	580,000	1,045,000	2,667,000
Constant 1996\$ levelized cost			
Mills/kWh	2.89	2.57	2.22
\$/ton NO _x removed	2,811	2,500	2,165
Note: 30 year life; 60% NO _x removal			

Exhibit 3-32 SCR Economics by NO _x Removal			
	40%	60%	80%
Capital cost (\$/kW)	52	54	57
Operating costs (\$/yr)	926,000	1,045,000	1,181,000
Constant 1996\$ levelized cost			
mills/kWh	2.39	2.57	2.79
\$/ton NO _x removed	3,502	2,500	2,036
Note: 250MWe; 0.35 lb/10 ⁶ Btu of inlet NO _x			

cost for various NO_x removal efficiencies for a 250-MWe unit are shown in Exhibit 3-32. For retrofit applications, the estimated capital costs were \$59–112/kW, depending on the size of the installation and the difficulty and scope of the retrofit. The levelized costs for the retrofit applications were \$1,850–5,100/ton (1996\$).

Commercial Applications

As a result of this demonstration, SCR technology has been shown to be applicable to existing and new utility generating capacity for removal of NO_x from the flue gas of virtually any size boiler. There are over 1,000 coal-fired utility boilers in active commercial service in the United States; these boilers represent a total generating capacity of approximately 300,000 MWe.

Contacts

Larry Monroe, (205) 257-7772
Southern Company Services, Inc.
Mail Stop 14N-8195
P.O. Box 2641
Birmingham, AL 35291-8195
lsmonroe@southernco.com
(205) 257-5367 (fax)

Victor K. Der, DOE/HQ, (301) 903-2700
victor.der@hq.doe.gov

Thomas A. Sarkus, NETL, (412) 386-5981
sarkus@netl.doe.gov

References

“*Demonstration of SCR Technology for the Control of NO_x Emissions from High-Sulfur Coal-Fired Utility Boilers.*” Fifth Annual Clean Coal Technology Conference: Technical Papers. Maxwell, J. D., *et al.* January 1997.

Demonstration of SCR Technology for the Control of NO_x Emissions from High-Sulfur, Coal-Fired Utility Boilers: Final Report. Vol. 1. Southern Company Services, Inc. October 1996. (Available from NTIS, Vol. 1 as DE97050873, Vol. 2: Appendixes A–N as DE97050874, and Vol. 3: Appendixes O–T as DE97050875.)

U.S. Department of Energy. *Demonstration of Selective Catalytic Reduction for the Control of NO_x Emissions from High-Sulfur, Coal-Fired Utility Boilers—Project Performance Summary.* November 2002.

180-MWe Demonstration of Advanced Tangentially Fired Combustion Techniques for the Reduction of NO_x Emissions from Coal-Fired Boilers

Project completed

Participant

Southern Company Services, Inc.

Additional Team Members

Gulf Power Company—cofunder and host

Electric Power Research Institute—cofunder

ABB Combustion Engineering, Inc.—cofunder and technology supplier

Location

Lynn Haven, Bay County, FL (Gulf Power Company's Plant Lansing Smith, Unit No. 2)

Technology

ABB Combustion Engineering's Low-NO_x Concentric Firing System (LNCFS™) with advanced overfire air (AOFA), clustered coal nozzles, and offset air

Plant Capacity/Production

180 MWe

Coal

Eastern bituminous, high reactivity

Project Funding

Total	\$8,553,665	100%
DOE	4,149,382	49
Participant	4,404,283	51

LNCFS is a trademark of ABB Combustion Engineering, Inc.

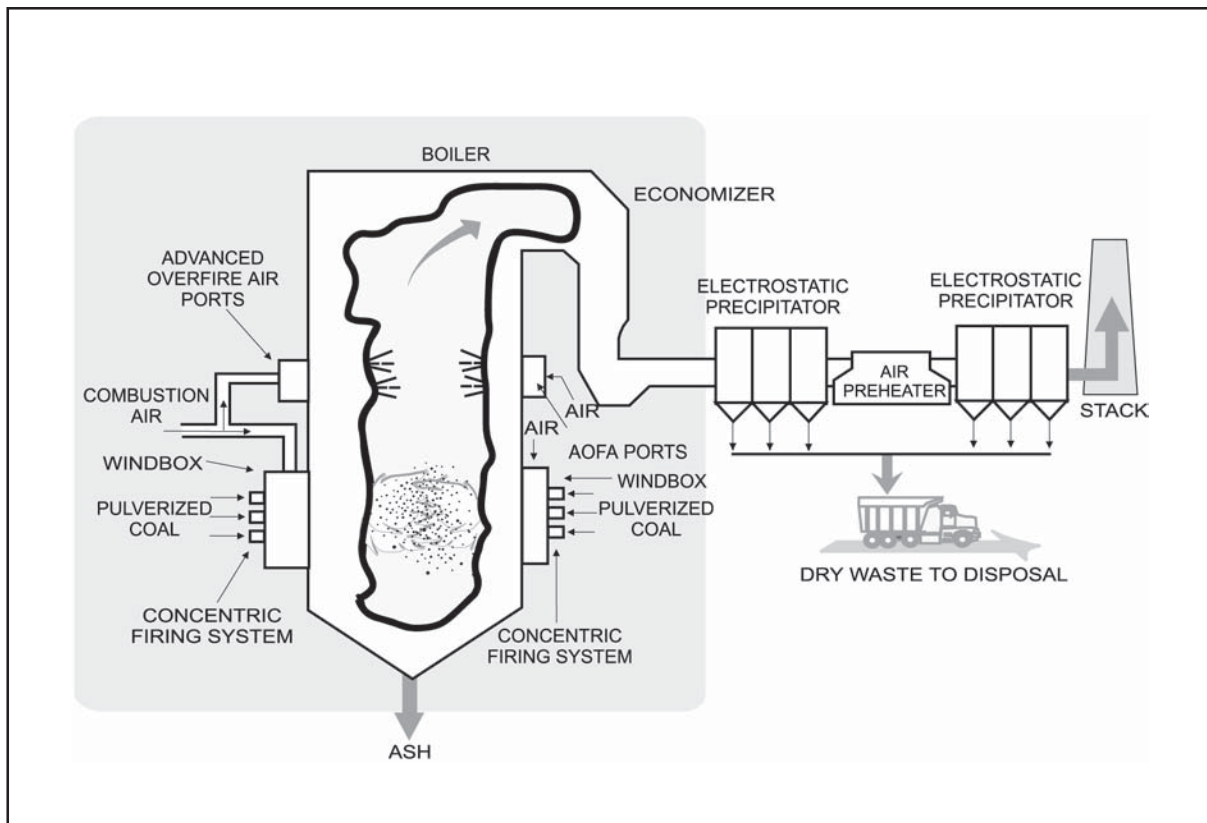

Project Objective

To demonstrate in a stepwise fashion the short- and long-term NO_x reduction capabilities of LNCFS™ levels I, II, and III on a single reference boiler.

Technology/Project Description

Technologies demonstrated included LNCFS™ levels I, II, and III. Each level of the LNCFS™ used different combinations of overfire air and clustered coal nozzle positioning to achieve NO_x reductions. With the LNCFS™, primary air and coal are surrounded by oxygen-rich secondary air that blankets the outer regions of the combustion zone. LNCFS™ I used a close-coupled overfire air (CCOFA) system integrated directly into the windbox of the boiler. A separated overfire air (SOFA) system located above the combustion zone was featured in the LNCFS™ II system. This was an advanced overfire

air system that incorporates back pressuring and flow measurement capabilities. CCOFA and SOFA were both used in the LNCFS™ III tangential-firing approach.

Carefully controlled short-term tests were conducted followed by long-term testing under normal load dispatch conditions. Long-term tests, which typically lasted 2–3 months for each phase, best represent the true emissions characteristics of each technology. Results presented are based on long-term test data.

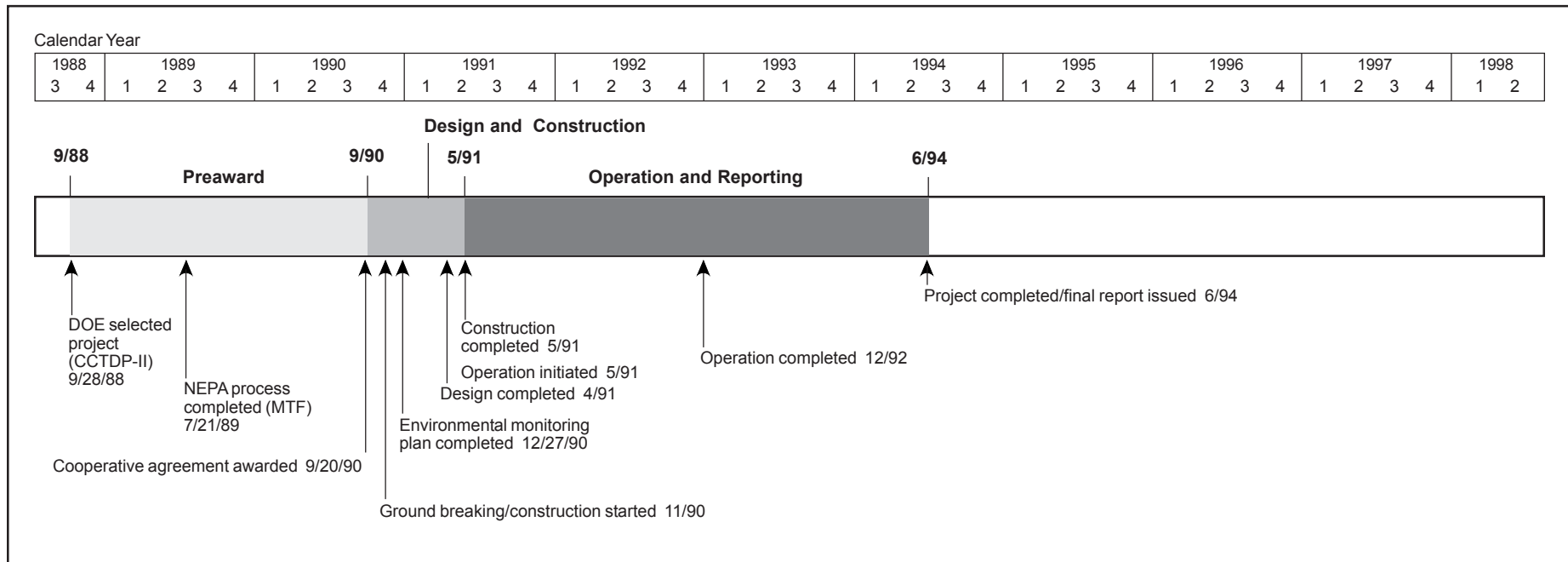

Results Summary

Environmental

- At full load, the NO_x emissions using LNCFS™ I, II, and III were 0.39, 0.39, and 0.34 lb/10⁶ Btu, respectively, which represent reductions of 37, 37, and 45% from the baseline emissions, respectively.
- Emissions with LNCFS™ were not sensitive to power outputs between 100 MWe and 200 MWe, but emissions increased significantly below 100 MWe, reaching baseline emission levels at 70 MWe.
- Because of reduced effectiveness at low loads, LNCFS™ proved marginal as a compliance option for peaking load conditions.
- Average CO emissions increased at full load.
- Air toxics testing found LNCFS™ to have no clear-cut effect on the emissions of trace metals or acid gases. Volatile organic compounds (VOCs) appeared to be reduced and semi-volatile compounds increased.

Operational

- Loss-on-ignition (LOI) was not sensitive to the LNCFS™ retrofits, but very sensitive to coal fineness.
- Furnace slagging was reduced, but backpass fouling was increased for LNCFS™ II and III.
- Boiler efficiency and unit heat rate were impacted minimally.
- Unit operation was not significantly affected, but operating flexibility of the unit was reduced at low loads with LNCFS™ II and III.

Economic

- The capital cost estimate for LNCFS™ I was \$5–15/kW, and for LNCFS™ II and III, \$15–25/kW (1993\$).
- The cost-effectiveness for LNCFS™ I was \$103/ton of NO_x removed; LNCFS™ II, \$444/ton; and LNCFS™ III, \$400/ton (1993\$).

Project Summary

LNCFS™ technology was designed for tangentially fired boilers, which represent a large percentage of the pre-NSPS coal-fired generating capacity. The technology reduces NO_x by staging combustion vertically in the boiler with separate coal and air injectors, and horizontally by creating fuel-rich and lean zones with offset air nozzles. The objective was to determine NO_x emission reductions and impact on boiler performance under normal dispatch and operating conditions over the long term. By using the same boiler, the demonstration provided direct comparative performance analysis of the three configurations. Short-term parametric testing enabled extrapolation of results to other tangentially fired units by evaluating the relationship between NO_x emissions and key operating parameters.

At the time of the demonstration, specific NO_x emission regulations were being formulated under the CAAA. The data developed over the course of this project provided needed real-time input to regulation development.

Exhibit 3-33 shows the various LNCFS™ configurations used to achieve staged combustion. In addition to overfire air, the LNCFS™ incorporates other NO_x-reducing techniques into the combustion process as shown in Exhibit 3-34. Using offset air, two concentric circular combustion regions are formed. The majority of the coal is contained in the fuel-rich zone. This region is surrounded by a fuel-lean zone containing combustion air. The size of this outer annulus of combustion air can be varied using adjustable offset air nozzles.

Operational Performance

Exhibit 3-35 summarizes the impacts of LNCFS™ on unit performance.

Environmental Performance

At full load, LNCFS™ I, II, and III reduced NO_x emissions by 37, 37, and 45%, respectively. Exhibit 3-36 presents the NO_x emission estimates obtained from the assessment of the average annual NO_x emissions for three dispatch scenarios.

Air toxics testing found LNCFS™ to have no clear-cut effect on the emission of trace metals or acid gases. The data provided marginal evidence for a decreased emission

Exhibit 3-33
LNCFS™ Configurations

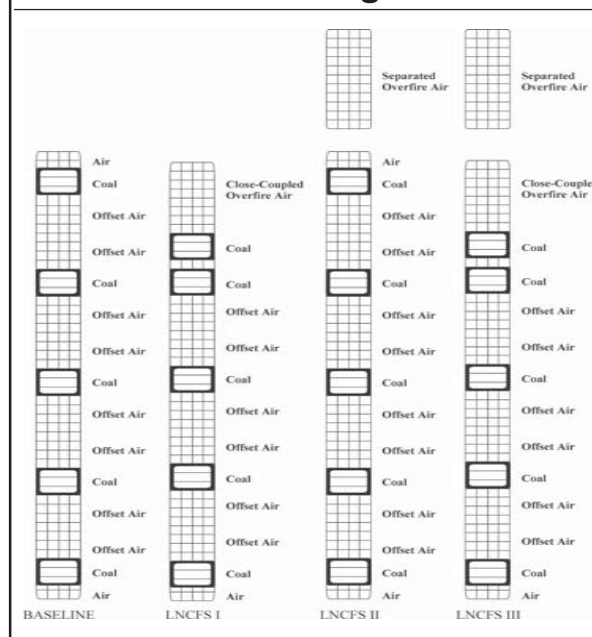
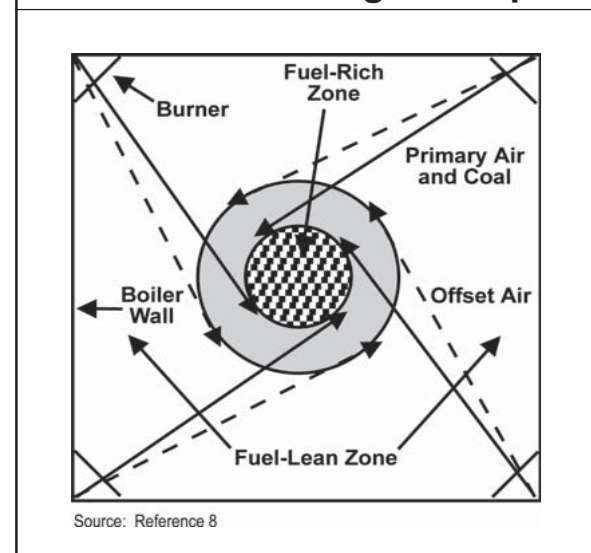

Exhibit 3-34
Concentric Firing Concept



of chromium. The effect on aldehydes/ketones could not be assessed because baseline data were compromised. VOCs appeared to be reduced and semi-volatile compounds increased. The increase in semi-volatile compounds was deemed to be consistent with increases in the amount of unburned carbon in the ash.

Economic Performance

LNCFS™ II was the only complete retrofit (LNCFS™ I and III were modifications of LNCFS™ II), and therefore capital cost estimates were based on the Lansing Smith Unit No. 2 retrofit as well as other tangentially fired LNCFS™ retrofits. The capital cost ranges in 1993 dollars follow:

- LNCFS™ I—\$5–15/kW
- LNCFS™ II—\$15–25/kW
- LNCFS™ III—\$15–25/kW

Site-specific considerations have a significant effect on capital costs; however, the above ranges reflect actual

experience and are planning estimates. The actual capital cost for LNCFS™ II at Lansing Smith Unit No. 2 was \$3 million, or \$17/kW, which falls within the projected range.

The cost-effectiveness of the LNCFS™ technologies is based on the capital and operating and maintenance costs and the NO_x removal efficiency of the technologies. The cost-effectiveness of the LNCFS™ technologies follows (based on a levelization factor of 0.144; 1993 constant dollars):

- LNCFS™ I—\$103/ton of NO_x removed
- LNCFS™ II—\$444/ton of NO_x removed
- LNCFS™ III—\$400/ton of NO_x removed

Commercial Applications

The LNCFS™ technology has potential commercial application to all the 423 U.S. pulverized coal, tangentially fired utility units. These units range from 25 MWe to 950 MWe in size and fire a wide range of coals, from low-volatile bituminous through lignite.

Exhibit 3-35
Unit Performance Impacts Based on Long-Term Testing

	Baseline	LNCFS™ I	LNCFS™ II	LNCFS™ III
Avg CO at full load (ppm)	10	12	22	33
Avg excess O ₂ at full load (%)	3.7	3.2	4.5	4.3
LOI at full load (%)	4.8	4.6	4.2	5.9
O ₂ (%)	4.0	3.9	5.3	4.7
Steam outlet conditions	Satisfactory at full load; low temperatures at low loads	Full load: 5–10 °F lower than baseline Low loads: 10–30 °F lower than baseline	Same as baseline	160–200 MWe: satisfactory 80 MWe: 15–35 °F lower than baseline
Furnace slagging and backpass fouling	Medium	Medium	Reduced slagging, but increased fouling	Reduced slagging, but increased fouling
Operating flexibility	Normal	Same as baseline	More care required at low loads	More difficult to operate than other systems
Boiler efficiency (%)	90	90.2	89.7	89.85
Efficiency change (points)	N/A	+0.2	-0.3	-0.15
Turbine heat rate (Btu/kWh)	9,000	9,011	9,000	9,000
Unit net heat rate (Btu/kWh)	9,995	9,986	10,031	10,013
Change (%)	N/A	-0.1	+0.36	+0.18

Exhibit 3-36
Average Annual NO_x Emissions and Percent Reduction

Boiler Duty Cycle	Units	Baseline	LNCFS™ I	LNCFS™ II	LNCFS™ III
Baseload (161.8 MWe avg)	Avg NO _x emissions (lb/10 ⁶ Btu)	0.62	0.41	0.41	0.36
	Avg reduction (%)		38.7	38.7	42.2
Intermediate load (146.6 MWe avg)	Avg NO _x emissions (lb/10 ⁶ Btu)	0.62	0.40	0.41	0.34
	Avg reduction (%)		39.2	35.9	45.3
Peaking load (101.8 MWe avg)	Avg NO _x emissions (lb/10 ⁶ Btu)	0.59	0.45	0.47	0.43
	Avg reduction (%)		36.1	20.3	28.0

Contacts

Larry Monroe, (205) 257-7772
Southern Company Services, Inc.
Mail Stop 14N-8195
P.O. Box 2641
Birmingham, AL 35291-8195
lsmonroe@southernco.com
(205) 257-5367 (fax)

Victor K. Der, DOE/HQ, (301) 903-2700
victor.der@hq.doe.gov

Thomas A. Sarkus, NETL, (412) 386-5981
sarkus@netl.doe.gov

References

180-MWe Demonstration of Advanced Tangentially Fired Combustion Techniques for the Reduction of Nitrogen Oxide (NO_x) Emissions from Coal-Fired Boilers: Final Report and Key Project Findings. Report No. DOE/PC/89653-T14. Southern Company Services, Inc. February 1994. (Available from NTIS as DE94011174.)

180-MWe Demonstration of Advanced Tangentially Fired Combustion Techniques for the Reduction of Nitrogen Oxide (NO_x) Emissions from Coal-Fired Boilers—Plant Lansing Smith—Phase III and Final Environmental Monitoring Program Report. Southern Company Services, Inc. December 1993.

180-MWe Demonstration of Advanced Tangentially Fired Combustion Techniques for the Reduction of NO_x Emissions—Project Performance Summary. U.S. Department of Energy. June 1999.

Environmental Control Devices

Multi-Pollutant Control Technologies

SNOX™ Flue Gas Cleaning Demonstration Project

Project completed

Participant

ABB Environmental Systems

Additional Team Members

Ohio Coal Development Office—cofunder

Ohio Edison Company—cofunder and host

Haldor Topsoe a/s—patent owner for process technology, catalysts, and WSA Condenser

Snamprogetti, U.S.A.—cofunder and process designer

Location

Niles, Trumbull County, OH (Ohio Edison's Niles Station, Unit No. 2)

Technology

Haldor Topsoe's SNOX™ catalytic advanced flue gas cleanup system

Plant Capacity/Production

35-MWe equivalent slipstream from a 108-MWe boiler

Coal

Ohio bituminous, 2.8% sulfur

Project Funding

Total	\$31,438,408	100%
DOE	15,719,200	50
Participant	15,719,208	50

Project Objective

To demonstrate SNOX™ technology at an electric power plant using U.S. high-sulfur coals in which it will catalytically remove 95% of SO₂ and more than 90% of NO_x from flue gas and produce a salable by-product of concentrated sulfuric acid.

SNOX is a trademark of Haldor Topsoe a/s.

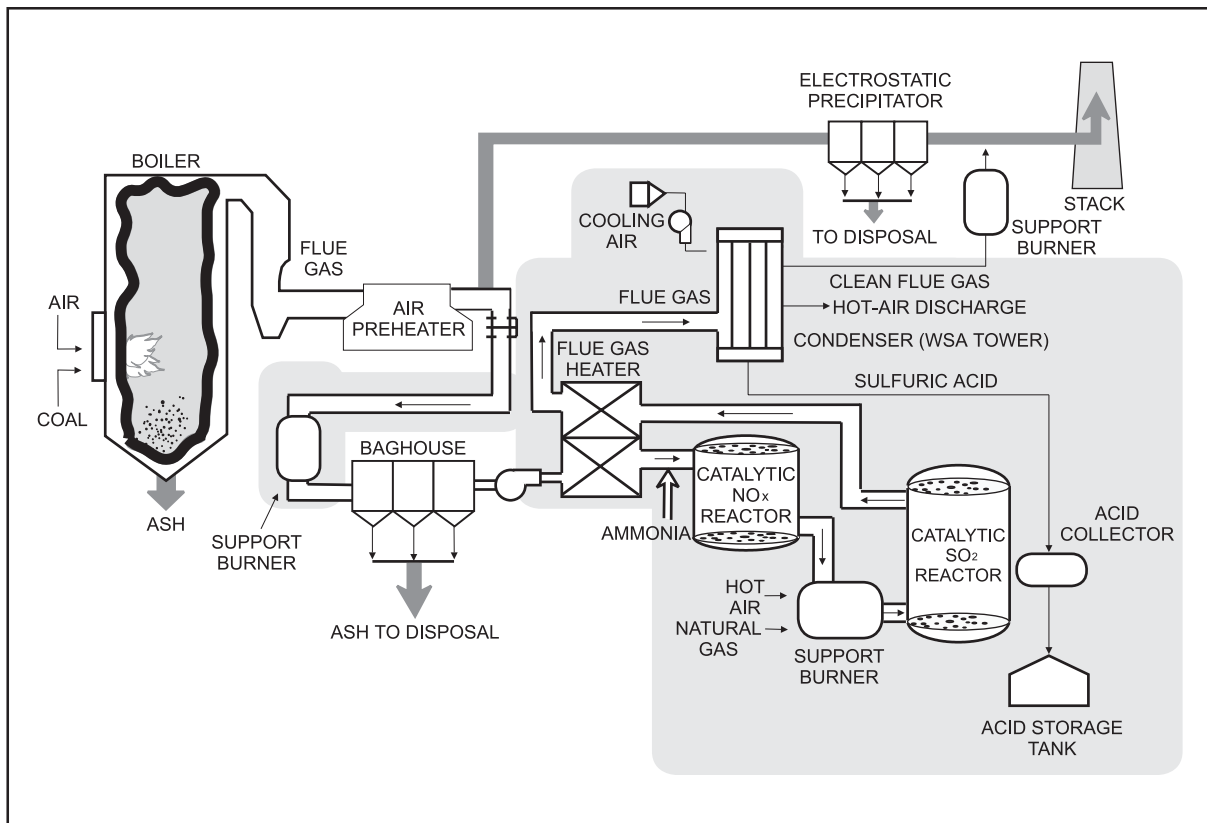

Technology/Project Description

In the SNOX™ process, the stack gas leaving the boiler is cleaned of fly ash in a high-efficiency fabric filter baghouse to minimize the cleaning frequency of the sulfuric acid catalyst in the downstream SO₂ converter. The ash-free gas is reheated, and NO_x is reacted with small quantities of ammonia in the first of two catalytic reactors where the NO_x is converted to harmless nitrogen and water vapor. The SO₂ is oxidized to SO₃ in a second catalytic converter. The gas then passes through a novel glass-tube condenser that allows SO₃ to hydrolyze to concentrated sulfuric acid.

Because the SO₂ catalyst follows the NO_x catalyst, any unreacted ammonia (slip) is oxidized in the SO₂ catalyst largely to nitrogen and water vapor. Downstream fouling by ammonia compounds is eliminated, permitting opera-

tion at higher than normal stoichiometries. These higher stoichiometries allow smaller catalyst volumes and high reduction efficiencies.

The technology was designed to remove 95% of the SO₂ and more than 90% of the NO_x from flue gas, and produce a salable sulfuric acid by-product using U.S. coals. This was accomplished without using sorbents and without creating waste streams.

The demonstration was conducted at Ohio Edison's Niles Station in Niles, Ohio. The demonstration unit treated a 35-MWe equivalent slipstream of flue gas from the 108-MWe Unit No. 2 boiler, which burned a 2.8% sulfur Ohio coal. The process steps were virtually the same as for a full-scale commercial plant, and commercial-scale components were installed and operated.

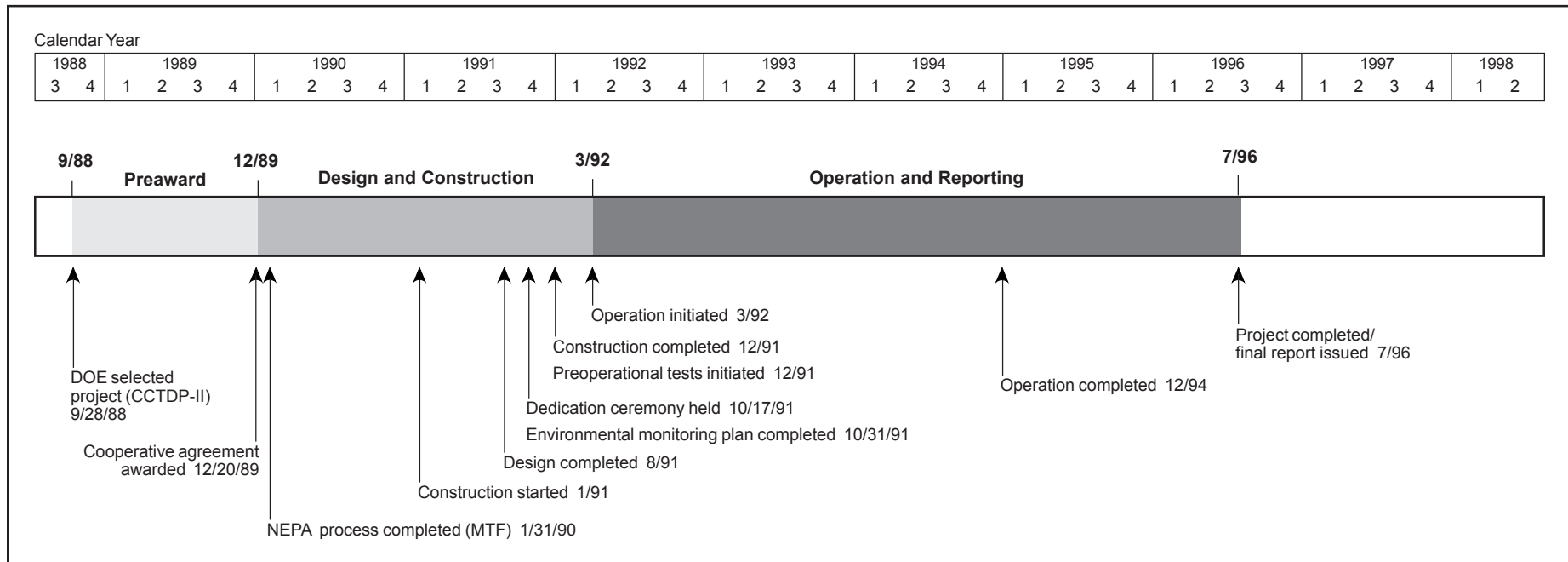

Results Summary

Environmental

- SO₂ removal efficiency was normally in excess of 95% for inlet concentrations, averaging about 2,000 ppm.
- NO_x reduction averaged 94% for inlet concentrations ranging from 500–700 ppm.
- Particulate removal efficiency for the high-efficiency fabric filter baghouse with SNOX™ system was greater than 99%.
- Sulfuric acid purity exceeded federal specifications for Class I acid.
- Air toxics testing showed high capture efficiency of most trace elements in the baghouse. A significant portion of the boron and almost all of the mercury escaped to the stack; but selenium and cadmium, normally a problem, were effectively captured in the acid drain, as were organic compounds.
- Absence of an alkali reagent contributed to elimination of secondary pollution streams and no increases in CO₂ emissions.

- Presence of the SO₂ catalyst virtually eliminated CO and hydrocarbon emissions.

Operational

- Having the SO₂ catalyst downstream of the NO_x catalyst eliminated ammonia slip and allowed the SCR to function more efficiently.
- Heat developed in the SNOX™ process was used to enhance thermal efficiency.

Economic

- Capital cost was estimated at \$305/kW for a 500-MWe unit firing 3.2% sulfur coal. The 15-year levelized incremental cost was estimated at 6.1 mills/kWh, \$219/ton of SO₂ removed, and \$198/ton of SO₂ and NO_x removed on a constant 1995 dollar basis.

Project Summary

No reagent was required for the SO₂ removal step because the SNOX™ process utilized an oxidation catalyst to convert SO₂ to SO₃ and ultimately to sulfuric acid. As a result, the process produced no waste streams.

In order to demonstrate and evaluate the performance of the SNOX™ process, general operating data were collected and parametric tests conducted to characterize the process and equipment. The system operated for approximately 8,000 hours and produced more than 5,600 tons of commercial-grade sulfuric acid. Many of the tests for the SNOX™ system were conducted at three loads—75, 100, and 110% of design capacity.

Environmental Performance

Particulate emissions from the process were very low (<1 mg/Nm³) due to the characteristics of the SO₂ catalyst and the sulfuric acid condenser (WSA Condenser). The Niles SNOX™ plant was fitted with a baghouse (rather than an ESP) on its inlet. This was not necessary for low particulate emissions, but rather was needed to maintain an acceptable cleaning frequency for the SO₂ catalyst. At operating temperature, the SO₂ catalyst retained about 90% of the dust that entered the catalyst vessel because of its sticky surface. Dust that passed through was subsequently removed in the WSA Condenser, which acted as a condensing particulate removal device (utilizing the dust particulates as nuclei).

Minimal or no increase in CO₂ emissions by the process resulted from two features—the lack of a carbonate-based alkali reagent that releases CO₂, and the fact that the process recovered additional heat from the flue gas to offset its parasitic energy requirements. Under most design conditions this heat recovery results in the net heat rate of the boiler remaining the same or decreasing after addition of the SNOX™ process, and consequently no increase occurs in CO₂ generation.

With respect to CO and hydrocarbons, the SO₂ catalyst acted to virtually eliminate these compounds as well. This aspect also positively affected the interaction of the NO_x and SO₂ catalysts. Because the SO₂ catalyst followed the NO_x catalyst, any unreacted ammonia (slip) was oxidized in the SO₂ catalyst to nitrogen, water vapor,

and a small amount of NO_x. As a result, downstream fouling by ammonia compounds was eliminated, and the SCR was operated at slightly higher than typical ammonia stoichiometries. These higher stoichiometries allowed smaller SCR catalyst volumes and permitted the attainment of very high reduction efficiencies. Normal operating stoichiometries for the SCR system were in the range of 1.02–1.05, and system reduction efficiencies averaged 94% with inlet NO_x levels of approximately 500–700 ppm.

Sulfur dioxide removal in the SNOX™ process was controlled by the efficiency of the SO₂-to-SO₃ oxidation, which occurred as the flue gas passed through the oxidation catalyst beds. The efficiency was controlled by two factors—space velocity and bed temperature. Space velocity governed the amount of catalyst necessary at design flue gas flow conditions, and gas and bed temperature had to be high enough to activate the SO₂ oxidation reaction. During the test program, SO₂ removal efficiency was normally in excess of 95% for inlet concentrations averaging about 2,000 ppm.

Sulfuric acid concentration and composition have met or exceeded the requirements of the federal specifications for Class I acid. During the design and construction of the SNOX™ demonstration, arrangements were made with a sulfuric acid supplier to purchase and distribute the acid from the plant. The acid has been sold to the agriculture industry for production of diammonium phosphate fertilizer and to the steel industry for pickling. Ohio Edison also has used a significant amount in boiler water demineralizer systems throughout its plants.

Air toxics testing conducted at the Niles SNOX™ plant measured the following substances:

- Five major and 16 trace elements including mercury, chromium, cadmium, lead, selenium, arsenic, beryllium, and nickel;
- Acids and corresponding anions (hydrogen chloride, hydrogen fluoride, chloride, fluoride, phosphate, sulfate);
- Ammonia and cyanide;
- Elemental carbon;
- Radionuclides;



The bottom portion of the SO₂ converter reactor, with the catalyst dust collector hopper mounted on steel rails (center).

- Volatile organic compounds;
- Semi-volatile compounds, including polynuclear aromatic hydrocarbons; and
- Aldehydes.

Most trace elements were captured in the baghouse along with the particulates. A significant portion of the boron and almost all of the mercury escaped to the stack; but selenium and cadmium, normally a problem, were effectively captured in the acid drain, as were organic compounds.

Operational Performance

Heat recovery was accomplished by the SNOX™ process. In a commercial configuration, it can be utilized in the thermal cycle of the boiler. The process generated recoverable heat in several ways. All of the reactions that took place with respect to NO_x and SO₂ removal were exothermic and increased the temperature of the flue gas. This heat, plus fuel-fired support heat added in the high-temperature SCR/SO₂ catalyst loop, was recovered in the WSA Condenser cooling air discharge for use in the furnace as combustion air. Because the WSA Condenser lowered the temperature of the flue gas to about 210 °F, compared with approximately 300 °F for a typical power plant, additional thermal energy was recovered along with that from the heats of reaction.

Economic Performance

The economic evaluation of the SNOX™ process showed a capital cost of approximately \$305/kW for a 500-MWe unit firing 3.2% sulfur coal. The 15-year levelized incremental cost was 6.1 mills/kWh on a constant dollar basis (1995\$). The equivalent costs of pollutant removed were \$219/ton of SO₂, and \$198/ton of SO₂ and NO_x.

Commercial Applications

The SNOX™ technology is applicable to all electric power plants and industrial/institutional boilers firing coal, oil, or gas. The high removal efficiency for NO_x and SO₂ makes the process attractive in many applications. Since the SNOX™ technology produces no solid waste, its marketability is enhanced in urban and other areas where solid waste disposal is a significant problem.

The host utility, Ohio Edison, is retaining the SNOX™ technology as a permanent part of the pollution control system at Niles Station to help Ohio Edison meet its overall SO₂/NO_x reduction goals.

Commercial SNOX™ plants also are operating in Denmark and Sicily. In Denmark, a 305-MWe plant has operated since August 1991. The boiler at this plant burns coals from various suppliers around the world, including the United States; the coals contain 0.5–3.0% sulfur. The plant in Sicily, operating since March 1991, has a capacity of about 30 MWe and fires petroleum coke.

Contacts

Paul Yosick, Project Manager, (865) 694-5300

Alstom Power, Inc.
1409 Center Port Boulevard
Knoxville, TN 37922
(865) 694-5213 (fax)
paul.yosick@power.alstom.com

Victor K. Der, DOE/HQ, (301) 903-2700

victor.der@hq.doe.gov

Thomas A. Sarkus, NETL, (412) 386-5981

sarkus@netl.doe.gov

References

Final Report Volume II: Project Performance and Economics. July 1996. Report No. DE-FC22-90PC89C55.

Final Report Volume I: Public Design. Report No. DOE/PC/89655-T21. (Available from NTIS as DE96050312.)

A Study of Toxic Emissions from a Coal-Fired Power Plant Utilizing the SNOX™ Innovative Clean Coal Technology Demonstration. Volume 1, Sampling/Results/Special Topics: Final Report. Report No. DOE/PC/93251-T3-Vol. 1. Battelle Columbus Operations. July 1994. (Available from NTIS as DE94018832.)

A Study of Toxic Emissions from a Coal-Fired Power Plant Utilizing the SNOX™ Innovative Clean Coal Technology Demonstration. Volume 2, Appendices: Final Report. Report No. DOE/PC/93251-T3-Vol. 2. Battelle Columbus Operations. July 1994. (Available from NTIS as DE94018833.)

ABB Environmental Systems SNOX™ Flue Gas Cleaning Demonstration Project—Project Performance Summary. U.S. Department of Energy. June 1999.



The SNOX™ demonstration at Ohio Edison's Niles Station Unit No. 2 achieved SO₂ removal efficiencies exceeding 95% and NO_x reduction effectiveness averaging 94%. Ohio Edison is retaining the SNOX™ technology as part of its environmental control system.

LIMB Demonstration Project Extension and Coolside Demonstration

Project completed

Participant

The Babcock & Wilcox Company

Additional Team Members

Ohio Coal Development Office—cofunder

Consolidation Coal Company—cofunder and technology supplier

Ohio Edison Company—host

Location

Lorain, Lorain County, OH (Ohio Edison's Edgewater Station, Unit No. 4)

Technology

The Babcock & Wilcox Company's (B&W) limestone injection multistage burner (LIMB) system; Babcock & Wilcox DRB-XCL® low-NO_x burners; Consolidation Coal Company's Coolside duct injection of lime sorbents

Plant Capacity/Production

105 MWe

Coal

Ohio bituminous, 1.6, 3.0, and 3.8% sulfur

Project Funding

Total	\$19,311,033	100%
DOE	7,591,655	39
Participant	11,719,378	61

Project Objective

To demonstrate, with a variety of coals and sorbents, that the LIMB process can achieve up to 50% NO_x and SO₂ reductions, and to demonstrate that the Coolside process can achieve SO₂ removal of up to 70%.

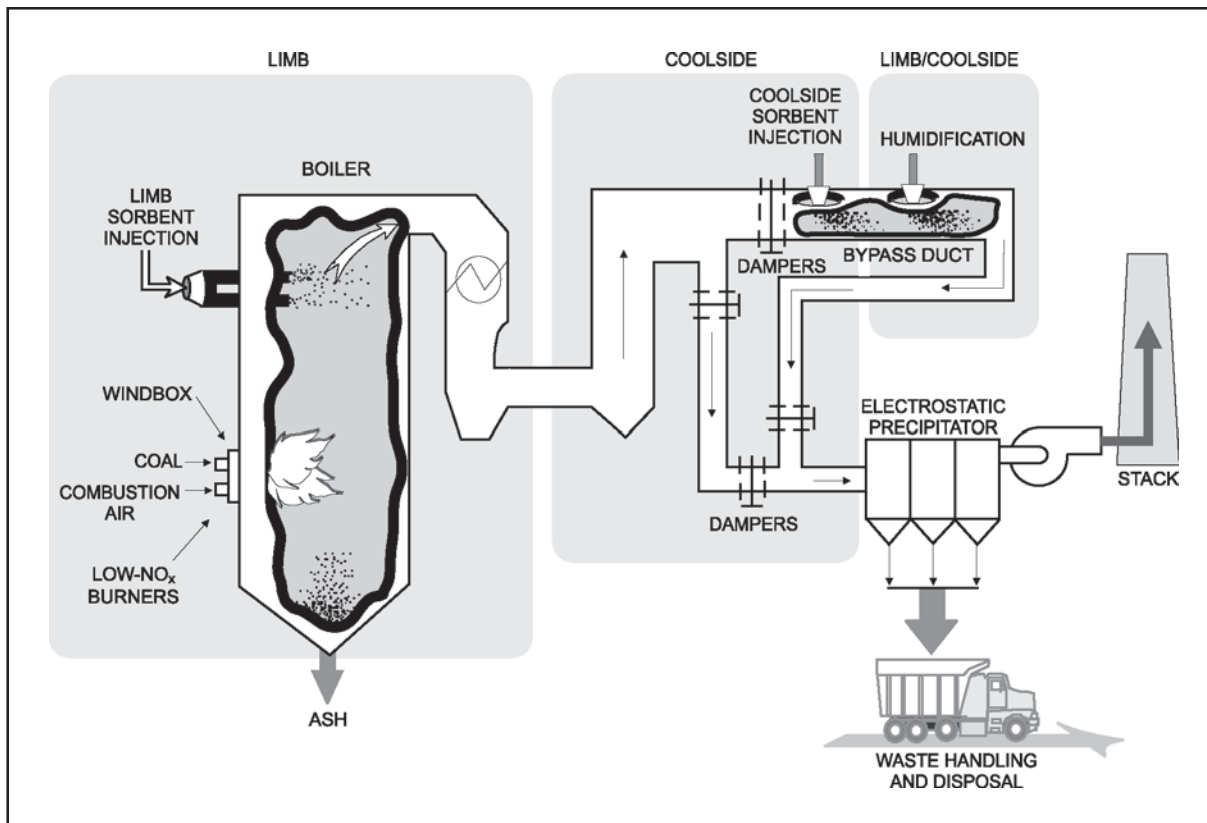

Technology/Project Description

The LIMB process reduces SO₂ by injecting dry sorbent into the boiler at a point above the burners. The sorbent then travels through the boiler and is removed along with fly ash in an electrostatic precipitator (ESP) or baghouse. Humidification of the flue gas before it enters an ESP is necessary to maintain normal ESP operation and to enhance SO₂ removal. Combinations of three bituminous coals (1.6, 3.0, and 3.8% sulfur) and four sorbents were tested. Other variables examined were stoichiometry, humidifier outlet temperature, and injection elevation level in the boiler.

In the Coolside process, dry sorbent is injected into the flue gas downstream of the air preheater, followed by flue gas humidification. Humidification enhances ESP performance and SO₂ absorption. SO₂ absorption is improved by

dissolving sodium hydroxide (NaOH) or sodium carbonate (Na₂CO₃) in the humidification water. The spent sorbent is collected with the fly ash, as in the LIMB process. Bituminous coal with 3.0% sulfur was used in testing.

Babcock & Wilcox DRB-XCL® low-NO_x burners, which control NO_x through staged combustion, were used in demonstrating both LIMB and Coolside technologies.

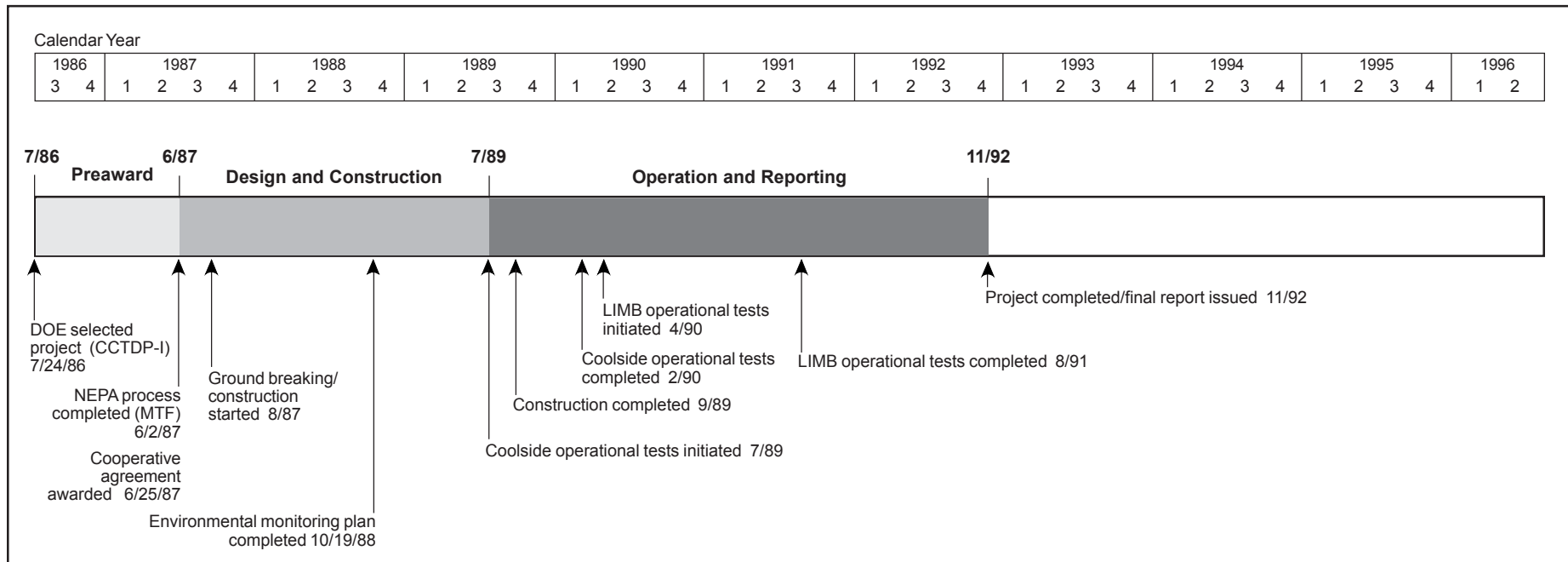

Results Summary

Environmental

- LIMB SO₂ removal efficiencies at a calcium-to-sulfur (Ca/S) molar ratio of 2.0, and minimal humidification across the range of coal sulfur contents were 53–61% for ligno lime, 51–58% for calcitic lime, 45–52% for dolomitic lime, and 22–25% for limestone ground to 80% less than 44 microns (325 mesh).
- LIMB SO₂ removal efficiency increased from 22–25% to 32% using limestone ground to 100% less than 44 microns, and increased an additional 5–7% when ground to 100% less than 10 microns.
- LIMB SO₂ removal efficiencies were enhanced by about 10% with humidification at a 20 °F approach-to-saturation temperature.
- LIMB, which incorporated Babcock & Wilcox DRB-XCL[®] low-NO_x burners, achieved 40–50% NO_x reduction.

- Coolside SO₂ removal efficiency was 70% at a Ca/S molar ratio of 2.0, a sodium-to-calcium (Na/Ca) ratio of 0.2, and a 20 °F approach-to-saturation temperature using commercial hydrated lime and 2.8–3.0% sulfur coal.
- Sorbent recycle tests demonstrated the potential to improve sorbent utilization.

Operational

- Humidification enhanced ESP performance, which enabled opacity levels to be kept well within limits.
- LIMB availability was 95%. Coolside did not undergo testing of sufficient length to establish availability.
- Humidifier performance indicated that operation in a vertical rather than horizontal mode would be better.

Economic

- LIMB capital costs were \$31–102/kW (1992\$) for plants ranging from 100–500 MWe and coals with 1.5–3.5% sulfur, with a target SO₂ reduction of 60%. Annual levelized costs (15-year) for this range of conditions were \$392–791/ton of SO₂ removed.

- Coolside capital costs were \$69–160/kW (1992\$) for plants ranging from 100–500 MWe and coals with 1.5–3.5% sulfur, with a target SO₂ reduction of 70%. Annualized levelized costs (15-year) for this range of conditions were \$482–943/ton of SO₂ removed.

Project Summary

The initial expectation with LIMB technology was that limestone calcined by injection into the furnace would achieve adequate SO₂ capture. Use of limestone in lieu of the significantly more expensive lime would keep operating costs relatively low. However, the demonstration showed that, even with fine grinding of the limestone and deep humidification, performance with limestone was marginal. As a result, a variety of hydrated limes were evaluated in the LIMB configuration, demonstrating enhanced performance. Although LIMB performance was enhanced by applying humidification to the point of approaching adiabatic saturation temperatures, performance did not rely on this deep humidification.

Coolside design was dependent upon deep humidification to improve sorbent reactivity and the use of hydrated lime. Sorbent injection was downstream of the furnace. In addition, sorbent activity was enhanced by dissolving sodium hydroxide (NaOH) or sodium carbonate (Na₂CO₃) in the humidification water.

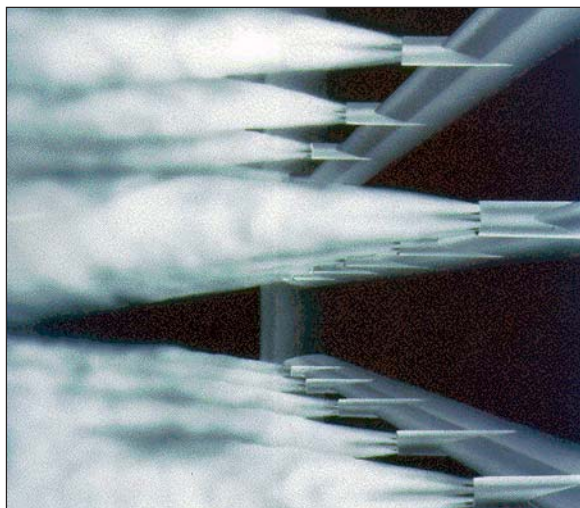

Water mist, sprayed into the flue gas, enhanced sulfur capture by the sorbent by approximately 10% in the LIMB process when 20 °F approach-to-saturation was used.

Environmental Performance (LIMB)

LIMB tests were conducted over a range of Ca/S molar ratios and humidification conditions while burning Ohio coals with nominal sulfur contents of 1.6, 3.0, and 3.8% by weight. Each of four different sorbents was injected while burning each of the three different coals with one exception. Other variables examined were stoichiometry, humidifier outlet temperature, and injection elevation level in the boiler. Exhibit 3-37 summarizes SO₂ removal efficiencies for the range of sorbents and coals tested.

While injecting commercial limestone with 80% of the particles less than 44 microns in size (minus 325 mesh), removal efficiencies of about 22% were obtained at a stoichiometry of 2.0 while burning 1.6% sulfur coal. However, removal efficiencies of about 32% were achieved at a stoichiometry of 2.0 when using a limestone with a smaller particle size (*i.e.*, all particles were less than 44 microns). A third limestone with essentially all particles less than 10 microns was used to determine the removal efficiency limit. The removal efficiency for this very fine limestone was approximately 5–7% higher than that obtained under similar conditions for limestone with particles all sized less than 44 microns.

During the design phase, it was expected that injection at the 181-foot plant elevation level inside the boiler would permit the introduction of the limestone at close to the optimum furnace temperature of 2,300 °F. Testing confirmed that injection at this level, just above the nose of the boiler, yielded the highest SO₂ removal. Injection was also performed at the 187-foot level and similar removals were observed. Removal efficiencies while injecting at these levels were about 5% higher than while injecting sorbent at the 191-foot level.

Removal efficiencies were enhanced by approximately 10% over the range of stoichiometries tested when using humidification down to a 20 °F approach-to-saturation temperature. The continued use of the low-NO_x burners resulted in an overall average NO_x emissions level of 0.43 lb/10⁶ Btu, which is about a 45% reduction.

Exhibit 3-37 LIMB SO₂ Removal Efficiencies (Percent)

Sorbent	Nominal Coal Sulfur Content		
	3.8%	3.0%	1.6%
Ligno lime	61	63	53
Commercial calcitic lime	58	55	51
Dolomitic lime	52	48	45
Limestone (80% <44 microns)	NT	25	22

NT = Not tested
Test conditions: injection at 181 ft, Ca/S molar ratio of 2.0, minimal humidification.

Operational Performance (LIMB)

Long-term test data showed that the LIMB system was available about 95% of the time it was called upon to operate. Even with minimal humidification, ESP performance was adequately enhanced to keep opacity levels well below the permitted limit. Opacity was generally in the 2–5% range (limit was 20%).

Environmental Performance (Coolside)

The Coolside process was tested while burning compliance (1.2–1.6% sulfur) and noncompliance (2.8–3.2% sulfur) coals. Objectives of the full-scale test program were to verify short-term process operability and to develop a design performance database to establish process economics for Coolside. Key process variables—Ca/S molar ratio, Na/Ca molar ratio, and approach-to-saturation temperatures—were evaluated in short-term (6–8 hours) parametric tests and longer term (1–11 days) process operability tests.

The test program demonstrated that the Coolside process routinely achieved 70% SO₂ removal at design conditions of 2.0 Ca/S molar ratio, 0.2 Na/Ca molar ratio, and 20 °F approach-to-saturation temperature using commercially available hydrated lime. Coolside SO₂ removal depended

**Exhibit 3-38
LIMB Capital Cost Comparison
(1992 \$/kW)**

Coal (%S)	LIMB	Coolside	LSFO	LIMB	Coolside	LSFO
	100 MWe			150 MWe		
1.5	93	150	413	66	116	312
2.5	95	154	421	71	122	316
3.5	102	160	425	73	127	324
	250 MWe			500 MWe		
1.5	46	96	228	31	69	163
2.5	50	101	235	36	76	169
3.5	54	105	240	40	81	174

**Exhibit 3-39
LIMB Annual Levelized Cost Comparison
(1992 \$/Ton of SO₂ Removed)**

Coal (%S)	LIMB	Coolside	LSFO	LIMB	Coolside	LSFO
	100 MWe			150 MWe		
1.5	791	943	1418	653	797	1098
2.5	595	706	895	520	624	692
3.5	525	629	665	461	570	527
	250 MWe			500 MWe		
1.5	549	704	831	480	589	623
2.5	456	567	539	416	502	411

on Ca/S molar ratio, Na/Ca molar ratio, approach-to-adiabatic-saturation, and the physical properties of the hydrated lime. Sorbent recycle showed significant potential to improve sorbent utilization. The observed SO₂ removal with recycled sorbent alone was 22% at 0.5 available Ca/S molar ratio and 18 °F approach-to-adia-

batic-saturation. The observed SO₂ removal with simultaneous recycle and fresh sorbent feed was 40% at 0.8 fresh Ca/S molar ratio, 0.2 fresh Na/Ca molar ratio, 0.5 available recycle, and 18 °F approach-to-adiabatic-saturation.

Operational Performance (Coolside)

Floor deposits experienced in the ductwork with the horizontal humidification led designers to consider a vertical unit in a commercial configuration. Short-term testing did not permit evaluation of Coolside system availability.

Economic Performance (LIMB & Coolside)

Economic comparisons were made between LIMB, Coolside, and a wet scrubber with limestone injection and forced oxidation (LSFO). Assumptions on performance were SO₂ removal efficiencies of 60, 70, and 95% for LIMB, Coolside, and LSFO, respectively. The EPRI TAG™ methods were used for the economics, which are summarized in Exhibits 3-38 and 3-39.

Commercial Application

Both LIMB and Coolside technologies are applicable to most utility and industrial coal-fired units, and provide alternatives to conventional wet flue gas desulfu-

rization processes. LIMB and Coolside can be retrofitted with modest capital investment and downtime, and their space requirements are substantially less than for conventional flue gas desulfurization processes.

Contacts

Greg Bielawski (330) 860-1591
The Babcock & Wilcox Company
20 South Van Buren Avenue
P.O. Box 351
Barberton, OH 44203-0351
gtbielawski@babcock.com
(330) 860-9292 (fax)

Victor K. Der, DOE/HQ, (301) 903-2700
victor.der@hq.doe.gov

John C. McDowell, NETL, (412) 386-6175
mcdowell@netl.doe.gov

References

LIMB Demonstration Project Extension and Coolside Demonstration: Final Report. Report No. DOE/PC/79798-T27. The Babcock & Wilcox Company. November 1992. (Available from NTIS as DE93005979.)

The Edgewater Coolside Process Demonstration: A Topical Report. Report No. DOE/PC/79798-T26. CONSOL, Inc. February 1992. (Available from NTIS as DE93001722.)

Coolside and LIMB: Sorbent Injection Demonstrations Nearing Completion. Topical Report No. 2. U.S. Department of Energy and The Babcock & Wilcox Company. September 1990.

SOx-NOx-Rox Box™ Flue Gas Cleanup Demonstration Project

Project completed

Participant

The Babcock & Wilcox Company

Additional Team Members

Ohio Edison Company—cofunder and host

Ohio Coal Development Office—cofunder

Electric Power Research Institute—cofunder

Norton Company—cofunder and SCR catalyst supplier

3M Company—cofunder and filter bag supplier

Owens Corning Fiberglas Corporation—cofunder and filter bag supplier

Location

Dilles Bottom, Belmont County, OH (Ohio Edison Company's R.E. Burger Plant, Unit No. 5)

Technology

The Babcock & Wilcox Company's SOx-NOx-Rox Box™ (SNRB™) process

Plant Capacity/Production

5-MWe equivalent slipstream from a 156-MWe boiler

Coal

Bituminous coal blend, 3.7% sulfur average

Project Funding

Total	\$13,271,620	100%
DOE	6,078,402	46
Participant	7,193,218	54

SOx-NOx-Rox Box and SNRB are trademarks of The Babcock & Wilcox Company.

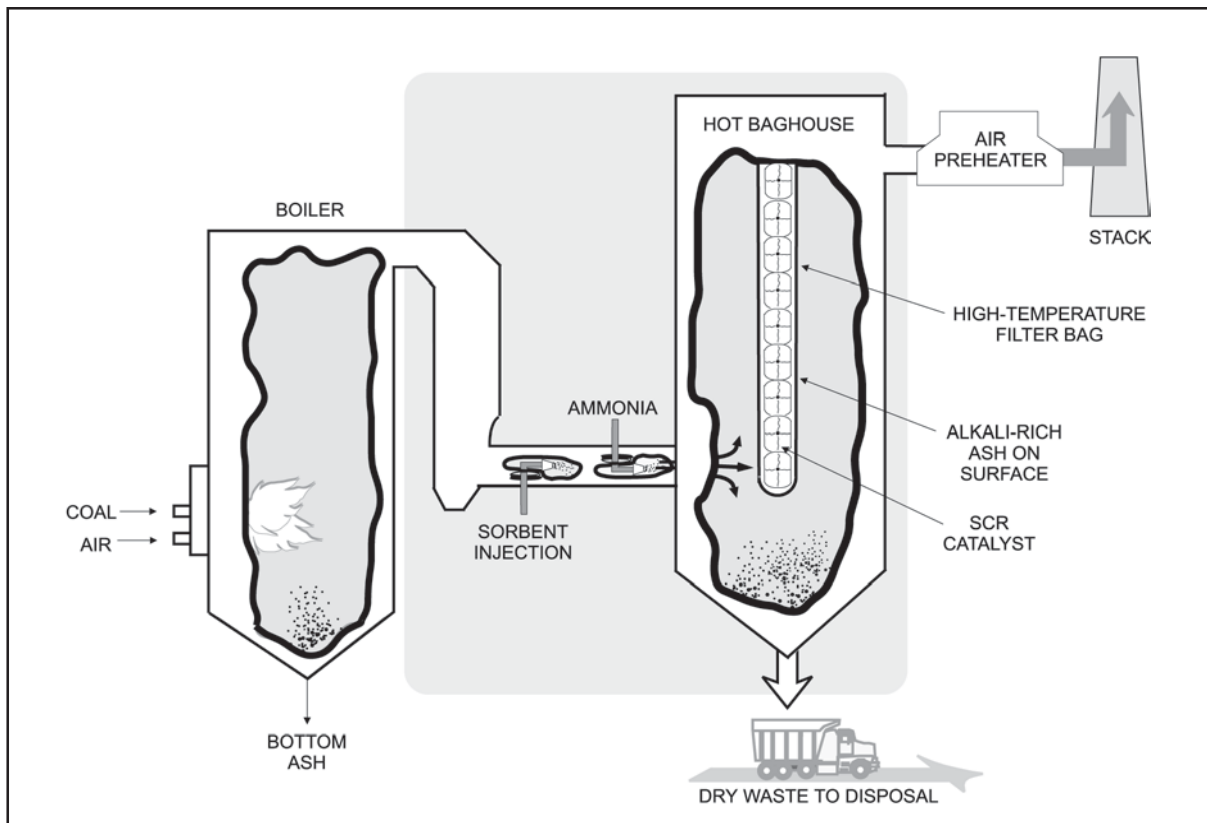

Project Objective

To achieve greater than 70% SO₂ removal and 90% or higher reduction in NO_x emissions while maintaining particulate emissions below 0.03 lb/10⁶ Btu.

Technology/Project Description

The SNRB™ process combines the removal of SO₂, NO_x, and particulates in one unit—a high-temperature baghouse. SO₂ removal is accomplished using either calcium- or sodium-based sorbent injected into the flue gas. The NO_x removal is accomplished by injecting ammonia (NH₃) to selectively reduce NO_x in the presence of a selective catalytic reduction (SCR) catalyst. Particulate removal is accomplished by high-temperature fiber bag filters.

The 5-MWe SNRB™ demonstration unit is large enough to demonstrate commercial-scale components while minimizing the demonstration cost. Operation at this scale

also permitted cost-effective control of the flue gas temperature, which allowed for evaluation of performance over a wide range of sorbent injection and baghouse operating temperatures. Thus, several different arrangements for potential commercial installations could be simulated.

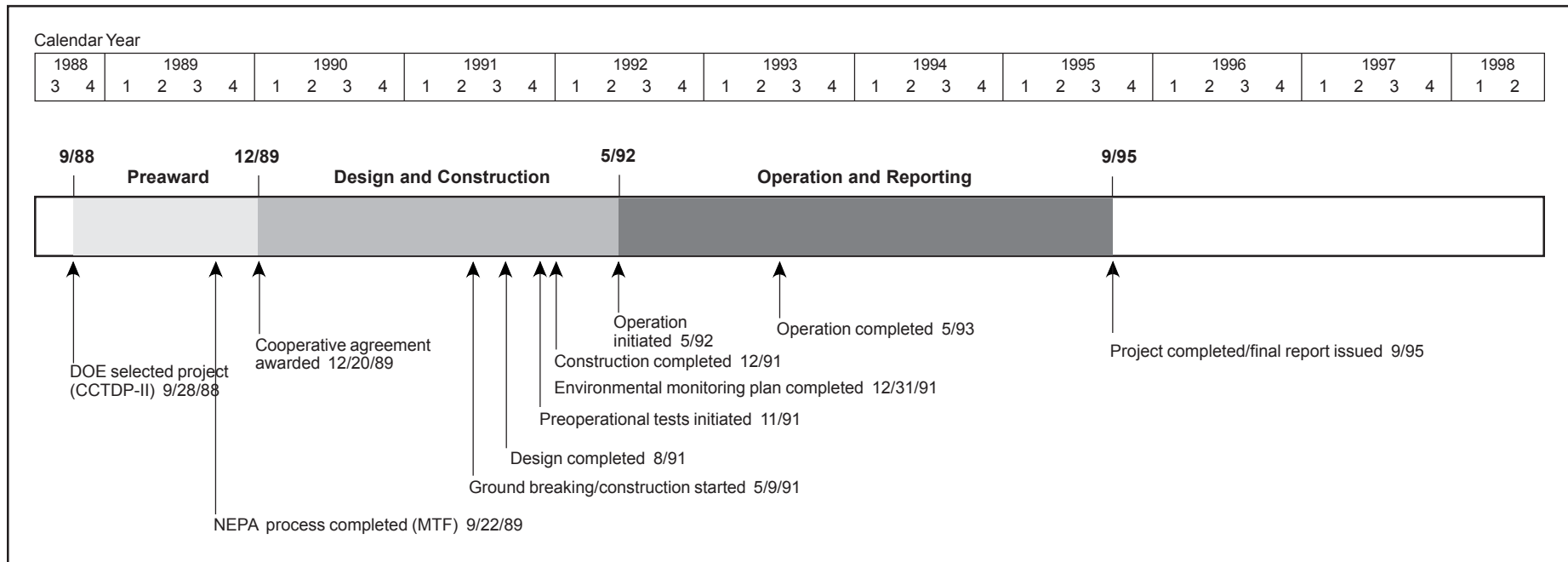

Results Summary

Environmental

- The SO₂ removal efficiency of 80% was achieved with commercial-grade lime at a calcium-to-sulfur (Ca/S) molar ratio of 2.0 and temperature of 800–850 °F.
- The SO₂ removal efficiency of 90% was achieved with sugar-hydrated lime and lignosulfonate-hydrated lime at a Ca/S molar ratio of 2.0 and temperature of 800–850 °F.
- The SO₂ removal efficiency of 80% was achieved with sodium bicarbonate at a sodium-to-sulfur (Na₂/S) molar ratio of 1.0 and temperature of 425 °F.
- The SO₂ emissions were reduced to less than 1.2 lb/10⁶ Btu with 3–4% sulfur coal, with a Ca/S molar ratio as low as 1.5 and Na₂/S molar ratio of 1.0.
- Injection of calcium-based sorbents directly upstream of the baghouse at 825–900 °F resulted in higher overall SO₂ removal than injection further upstream at temperatures up to 1,200 °F.

- The NO_x reduction of 90% was achieved with an NH₃/NO_x molar ratio of 0.9 and temperature of 800–850 °F.
- Air toxics removal efficiency was comparable to that of an electrostatic precipitator (ESP), except that hydrogen fluoride (HF) was reduced by 84% and hydrogen chloride (HCl) by 95%.

Operational

- Calcium utilization was 40–45% for SO₂ removals of 85–90%.
- Norton Company's NC-300 zeolite SCR catalyst showed no appreciable physical degradation or change in catalyst activity over the course of the demonstration.
- No excessive wear or failures occurred with the filter bags tested: 3M's Nextel ceramic fiber filter bag and Owens Corning Fiberglas S-Glass filter bag.

Economic

- Capital cost in 1994 dollars for a 150-MWe retrofit was \$253/kW, assuming 3.5% sulfur coal, baseline NO_x emissions of 1.02 lb/10⁶ Btu, 65% capacity factor, and 85% SO₂ and 90% NO_x removal.
- Levelized cost over 15 years in constant 1994 dollars was \$553/ton of SO₂ and NO_x removed.

Project Summary

SNRB™ incorporates two successful technology development efforts that offer distinct advantages over other control technologies. High-temperature filter bags and circular monolith catalyst developments enabled multiple emission controls in a single component with a low plan-area space requirement. As a post-combustion control system, it is simple to operate. The high-temperature bag provides a clean, high-temperature environment compatible with effective SCR operation, and a surface for enhanced SO₂/sorbent contact (creates a sorbent cake on the surface).

Environmental Performance

Four different sorbents were tested for SO₂ capture. Calcium-based sorbents included commercial grade hydrated lime, sugar-hydrated lime, and lignosulfonate-hydrated lime. In addition, sodium bicarbonate was tested. The optimal location for injecting the sorbent into the flue gas was immediately upstream of the baghouse. Essentially, the SO₂ was captured by the sorbent in the form of a filter cake on the filter bags (along with fly ash).

With the baghouse operating above 830 °F, injection of commercial-grade hydrated lime at Ca/S molar ratios of 1.8 and above resulted in SO₂ removals of over 80%. At a Ca/S molar ratio of 2.0, sugar-hydrated lime and lignosulfonate-hydrated lime increased performance by approximately 8%, for overall removal of approximately 90%. SO₂ removal of 85–90% was obtained with calcium utilization in the range of 40–45%. Injection of the calcium-based sorbents directly upstream of the baghouse at 825–900 °F resulted in higher overall SO₂ removal than injection further upstream at temperatures up to 1,200 °F.

The SO₂ removal using sodium bicarbonate was 80% at an Na₂/S molar ratio of 1.0 and 98% at an Na₂/S molar ratio of 2.0, at a significantly reduced baghouse temperature of 450–460 °F. The SO₂ emissions while burning a 3–4% sulfur coal were reduced to less than 1.2 lb/10⁶ Btu with a Ca/S molar ratio as low as 1.5 and Na₂/S molar ratio less than 1.0.

To capture NO_x, ammonia was injected between the sorbent injection point and the baghouse. The ammonia and

NO_x reacted to form nitrogen and water in the presence of Norton Company's NC-300 series zeolite SCR catalyst. With the catalyst being located inside the filter bags, it was well protected from potential particulate erosion or fouling. The sorbent reaction products, unreacted lime, and fly ash were collected on the filter bags and thus removed from the flue gas.

A NO_x emission reduction of 90% was readily achieved with ammonia slip limited to less than 5 ppm. This performance reduced NO_x emissions to less than 0.10 lb/10⁶ Btu. NO_x reduction was insensitive to temperatures over the catalyst design temperature range of 700–900 °F. Catalyst



The sorbent injection into the duct upstream of SO_x-NO_x-Rox BagTM system.

space velocity (volumetric gas flow/catalyst volume) had a minimal effect on NO_x removal over the range evaluated.

Turndown capability for tailoring the degree of NO_x reduction by varying the rate of ammonia injection was demonstrated for a range of 50–95% NO_x reduction. No appreciable physical degradation or change in the catalyst activity was observed over the duration of the test program. The degree of oxidation of SO₂ to SO₃ over the zeolite catalyst appeared to be less than 0.5%. (SO₂ oxidation is a concern for SCR catalysts containing vanadium.) Leach potential analysis of the catalyst after completion of the field test showed that the catalyst remained nonhazardous for disposal.

Particulate emissions were consistently below NSPS standards of 0.03 lb/10⁶ Btu, with an average of 0.018 lb/10⁶ Btu, which corresponds to a collective efficiency of 99.89%. Hydrated lime injection increased the baghouse inlet particulate loading from 5.6 to 16.5 lb/10⁶ Btu. Emissions testing with and without the SCR catalyst installed revealed no apparent differences in collection efficiency. On-line cleaning with a pulse air pressure of 30–40 lb/in² was sufficient for cleaning the bag/catalyst assemblies. Typically, one of five baghouse modules in service was cleaned every 30–150 minutes.

A comprehensive air toxics emissions monitoring test was performed at the end of the SNRB™ demonstration test program. The targeted emissions monitored included trace metals, volatile organic compounds, semi-volatile organic compounds, aldehydes, halides, and radionuclides. These species were a subset of the 189 hazardous substances identified in the CAAA. Measurements of mercury speciation, dioxins, and furans were unique features of this test program. The emissions control efficiencies achieved for various air toxics by the SNRB™ system were generally comparable to those of the conventional ESP at the power plant. However, the SNRB™ system did reduce HCl by an average of 95% and HF emissions by an average of 84%, whereas the ESP had no effect on these constituents.

Operation of the SNRB™ demonstration resulted in the production of approximately 830 tons of fly ash and by-product solids. An evaluation of potential uses for the by-product showed that the material might be used for

agricultural liming (if pelletized). Also, the solids potentially could be used as a partial cement replacement to lower the cost of concrete.

Operational Performance

A 3,800-hour durability test of three fabric filters was completed at the Filter Fabric Development Test Facility in Colorado Springs, Colorado in December 1992. No signs of failure were observed. All of the demonstration tests were conducted using the 3M Company Nextel ceramic fiber filter bags or the Owens Corning Fiberglas S-Glass filter bags. No excessive wear or failures occurred in over 2,000 hours of elevated temperature operation.

Economic Performance

For a 150-MWe boiler fired with 3.5% sulfur coal and NO_x emissions of 1.02 lb/10⁶ Btu, 65% capacity factor, and 85% SO_2 and 90% NO_x removal, the projected capital cost of a SNRB™ system is approximately \$253/kW (1994\$), including various technology and project contingency factors. A combination of fabric filter, SCR, and wet scrubber for achieving comparable emissions control has been estimated at \$360–400/kW. Variable operating costs are dominated by the cost of the SO_2 sorbent for a system designed for 85–90% SO_2 removal. Fixed operating costs primarily consist of system operating labor and projected labor and material for the hot baghouse and ash-handling systems. Levelized costs over 15 years in constant 1994 dollars are estimated at \$553/ton of SO_2 and NO_x removed.

Commercial Applications

Commercialization of the technology is expected to develop with an initial application equivalent to 50–100 MWe. The focus of marketing efforts is being tailored to match the specific needs of potential industrial, utility, and independent power producers for both retrofit and new plant construction. SNRB™ is a flexible technology that can be tailored to maximize control of SO_2 , NO_x , or combined emissions to meet current performance requirements while providing flexibility to address future needs.

Contacts

Dot K. Johnson, (330) 860-1757
The Babcock & Wilcox Company
20 South Van Buren Avenue
P.O. Box 351
Barberton, OH 44203-0351
dkjohnson1@babcock.com
(330) 860-2348 (fax)

Victor K. Der, DOE/HQ, (301) 903-2700
victor.der@hq.doe.gov

Thomas A. Sarkus, NETL, (412) 386-5981
sarkus@netl.doe.gov

References

SOx-NOx-Rox Box™ Flue Gas Cleanup Demonstration Final Report. Report No. DOE/PC/89656-T1. The Babcock & Wilcox Company. September 1995. (Available from NTIS as DE96003839.)

5-MWe SNRB™ Demonstration Facility: Detailed Design Report. The Babcock & Wilcox Company. November 1992.

Comprehensive Report to Congress on the Clean Coal Technology Program: SOx-NOx-Rox Box™ Flue Gas Cleanup Demonstration Project. The Babcock & Wilcox Company. Report No. DOE/FE-0145. U.S. Department of Energy. November 1989. (Available from NTIS as DE90004458.)

SOx-NOx-Rox Box™ Flue Gas Cleanup Demonstration Project—Project Performance Summary. U.S. Department of Energy. June 1999.



Workers lower one of the catalyst holder tubes into a mounting plate in the penthouse of the high-temperature baghouse.

Enhancing the Use of Coals by Gas Reburning and Sorbent Injection

Project completed

Participant

Energy and Environmental Research Corporation

Additional Team Members

Gas Research Institute—cofunder

State of Illinois, Department of Commerce & Community Affairs—cofunder

Illinois Power Company—host

City Water, Light and Power—host

Locations

Hennepin, Putnam County, IL (Illinois Power Company's Hennepin Plant, Unit No. 1)

Springfield, Sangamon County, IL (City Water, Light and Power's Lakeside Station, Unit No. 7)

Technology

Energy and Environmental Research Corporation's gas reburning and sorbent injection (GR-SI) process

Plant Capacity/Production

Hennepin: tangentially fired 80 MWe (gross), 71 MWe (net)

Lakeside: cyclone-fired 40 MWe (gross), 33 MWe (net)

Coal

Illinois bituminous, 3.0% sulfur

Project Funding

Total	\$37,588,955	100%
DOE	18,747,816	50
Participant	18,841,139	50

PromiSORB is a trademark of Energy and Environmental Research Corporation.

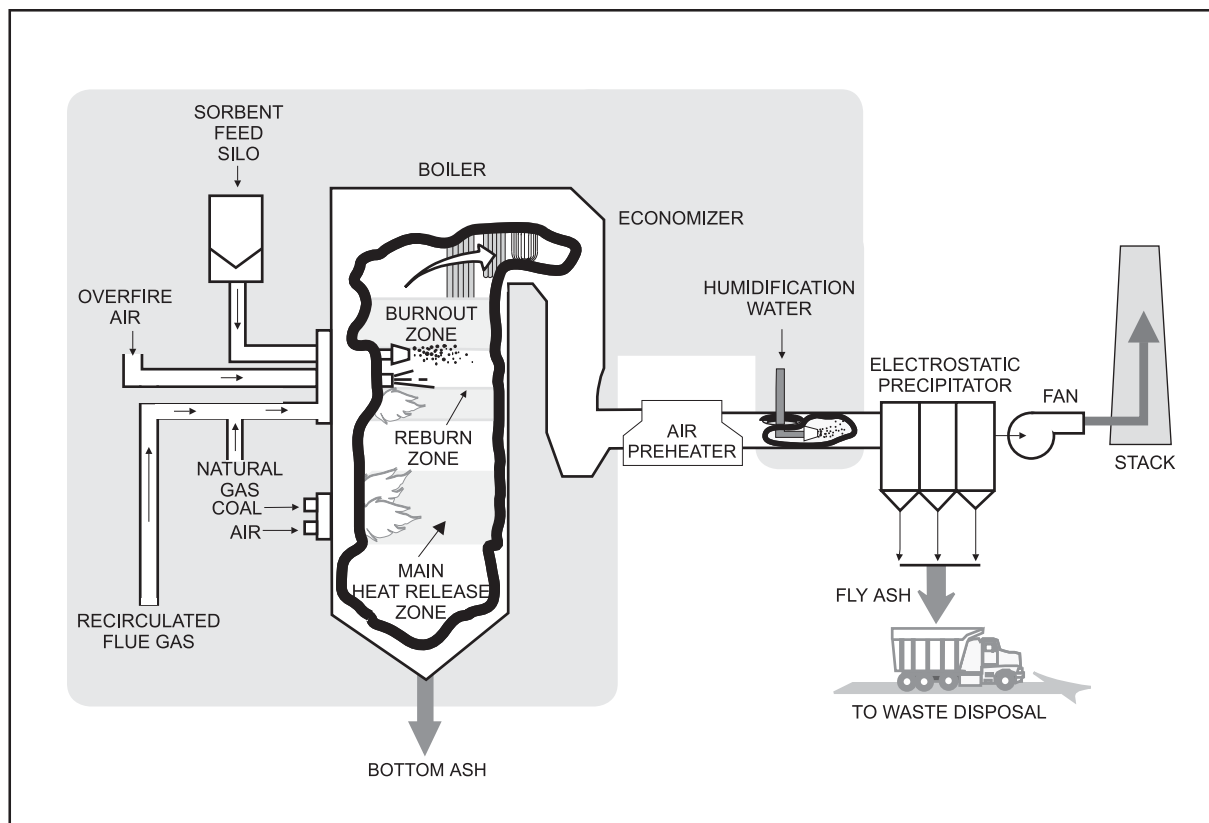

Project Objective

To demonstrate 60% NO_x reduction with gas reburning and at least 50% SO₂ removal with sorbent injection on two different boiler configurations—tangentially fired and cyclone-fired—while burning high-sulfur midwestern coal.

Technology/Project Description

In this process, 80–85% of the fuel as coal is supplied to the main combustion zone. The remaining 15–20% of the fuel, provided as natural gas, bypasses the main combustion zone and is injected above the main burners to form a reducing (reburning) zone in which NO_x is converted to molecular nitrogen (N₂). A calcium compound (sorbent) is injected in the form of dry, fine particulates above the reburning zone in the boiler. Hydrated lime (Ca(OH)₂) serves as the baseline sorbent.

This project demonstrated the GR-SI process on two separate boilers representing two different firing configurations—a tangentially fired, 80-MWe (gross) boiler at Illinois Power Company's Hennepin Plant in Hennepin, Illinois, and a cyclone-fired, 40-MWe (gross) boiler at City Water, Light and Power's Lakeside Station in Springfield, Illinois. Illinois bituminous coal containing 3% sulfur was the test coal for both Hennepin and Lakeside.

A comprehensive test program was conducted at each of the two sites, operating the equipment over a wide range of boiler conditions. Over 1,500 hours of operation were achieved, enabling a substantial amount of data to be obtained. Intensive measurements were taken to quantify the reductions in NO_x and SO₂ emissions, the impact on boiler equipment and operability, and all factors influencing costs.

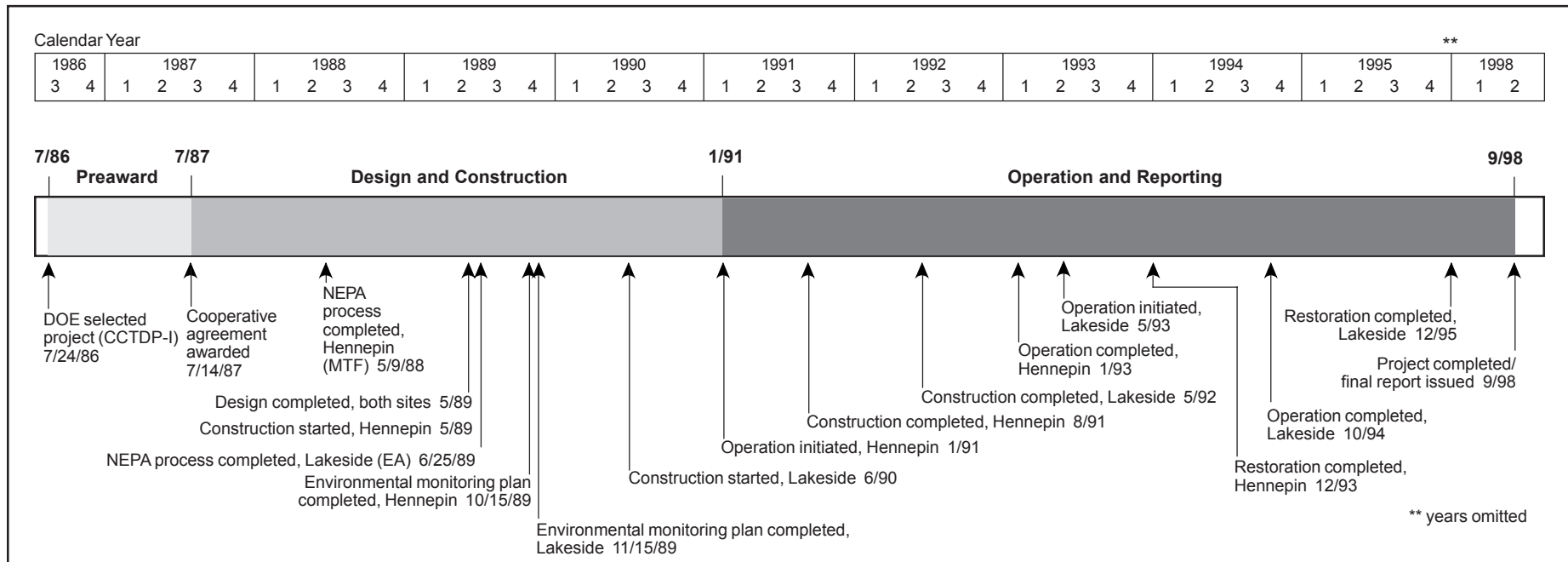

Results Summary

Environmental

- On the tangentially fired boiler, GR-SI NO_x reductions of up to 75% were achieved, and an average 67% reduction was realized at an average gas heat input of 18%.
- GR-SI SO₂ removal efficiency on the tangentially fired boiler averaged 53% with hydrated lime at a calcium-to-sulfur (Ca/S) molar ratio of 1.75 (corresponding to a sorbent utilization of 24%).
- On the cyclone-fired boiler, GR-SI NO_x reductions of up to 74% were achieved, and an average 66% reduction was realized at an average gas heat input of 22%.
- GR-SI SO₂ removal efficiency on the cyclone-fired boiler averaged 58% with hydrated lime at a Ca/S molar ratio of 1.8 (corresponding to a sorbent utilization of 24%).
- Particulate emissions were not a problem on either unit undergoing demonstration, but humidification had to be introduced at Hennepin to enhance electrostatic precipitator (ESP) performance.

- Three advanced sorbents tested achieved higher SO₂ capture efficiencies than the baseline Linwood hydrated lime. PromiSORB™ A achieved 53% SO₂ capture efficiency and 31% utilization without gas reburning (GR) at a Ca/S molar ratio of 1.75. Under the same conditions, PromiSORB™ B achieved 66% SO₂ reduction and 38% utilization, and high-surface-area hydrated lime achieved 60% SO₂ reduction and 34% utilization.

Operational

- Boiler efficiency decreased by approximately 1% as a result of increased moisture formed in combustion from natural gas use.
- There was no change in boiler tube wastage, tube metallurgy, or projected boiler life.

Economic

- Capital cost for GR was approximately \$15/kW plus the gas pipeline cost, if not in place (1996\$).
- Operating costs for GR were related to the gas/coal cost differential and the value of SO₂ emission allowances (because GR replaces some coal with gas, it also reduces SO₂ emissions).

- Capital cost for sorbent injection (SI) was approximately \$50/kW.
- Operating costs for SI were dominated by the cost of sorbent and sorbent/ash disposal costs. SI was estimated to be competitive at \$300/ton of SO₂ removed.

Project Summary

The GR-SI project demonstrated the success of gas reburning and sorbent injection technologies in reducing NO_x and SO_2 emissions. The process design conducted early in the project combined with the vast amount of data collected during the testing created a database enabling effective design for any site-specific utility or industrial application.

Environmental Performance (Hennepin)

Following optimization testing throughout 1991, the GR-SI long-term demonstration tests spanned 1992. The unit was operated at constant loads and with the system under dispatch load following. With the system under dispatch, the load fluctuated over a wide range from 40 MWe to a maximum load of 75 MWe. Over the long-term demonstration period, the average gross power output was 62 MWe.

For long-term demonstration testing, the average NO_x reduction was approximately 67%. The average SO_2 removal efficiency was over 53% at a Ca/S molar ratio of 1.75. (Linwood hydrated lime was used throughout these tests except for a few days when Marblehead lime was used.) CO emissions were below 50 ppm in most cases, but were higher during operation at low load.

A significant reduction in CO_2 was also realized. This was due to partial replacement of coal with natural gas having a lower carbon-to-hydrogen ratio. This cofiring with 18% natural gas resulted in a theoretical CO_2 emissions reduction of nearly 8% from the coal-fired baseline level. With flue gas humidification, ESP collection efficiencies greater than 99.8% and particulate emissions less than $0.025 \text{ lb}/10^6 \text{ Btu}$ were measured, even with an increase in inlet particulate loading resulting from sorbent injection. These levels compared favorably to baseline emissions of $0.035 \text{ lb}/10^6 \text{ Btu}$ and a collection efficiency greater than 99.5%.

Following completion of the long-term tests, three specially prepared sorbents were tested. Two were manufactured by the participant and contained proprietary additives to increase their reactivity toward SO_2 , and were referred to as PromiSORB™ A and B. The Illinois Geological Survey developed the other sorbent—high-

surface-area hydrated lime—in which alcohol is used to form a material that gives rise to a much higher surface area than that of conventionally hydrated limes.

The SO_2 capture without GR, at a nominal 1.75 Ca/S molar ratio, was 53% for PromiSORB™ A, 66% for PromiSORB™ B, 60% for high-surface-area hydrated lime, and 42% for Linwood lime. At a 2.6 Ca/S molar ratio, the PromiSORB™ B yielded 81% SO_2 removal efficiency.

Environmental Performance (Lakeside)

Parametric tests were conducted in three series: GR parametric tests, SI parametric tests, and GR-SI optimization tests. A total of 100 GR parametric tests were conducted at boiler loads of 33, 25, and 20 MWe. Gas heat input varied between 5% and 26%. The GR parametric tests achieved a NO_x reduction of approximately 60% at a gas heat input of 22–23%. Additional flow modeling and computer modeling studies indicated that smaller reburning fuel jet nozzles could increase reburning fuel mixing and thus improve the NO_x reduction performance.

A total of 25 SI parametric tests were conducted to isolate the effects of sorbent on boiler performance and operability. Results showed that SO_2 reduction levels varied with load because of the effect of temperature on the sulfation reaction. At a Ca/S molar ratio of 2.0, a 44% SO_2 reduction was achieved at full load (33 MWe); a 38% SO_2 reduction was achieved at mid load (25 MWe); and a 32% SO_2 reduction was achieved at low load (20 MWe).

In the GR-SI optimization tests, the two technologies were integrated. Modifications were made to the reburning fuel injection nozzles based on the results of the initial GR parametric tests and flow modeling studies. The total cross-sectional area of the reburning jets was decreased by 32% to increase the reburning jet's penetration characteristics. The decrease in nozzle diameter increased NO_x reduction by an additional 3–5% compared with the initial parametric tests. With GR-SI, total SO_2 reductions resulted from partial replacement of coal with natural gas and sorbent injection. At a gas heat input of 22% and Ca/S molar ratio of 1.8, average NO_x reduction during the long-term testing of GR-SI was 66% and the average SO_2 reduction was 58%.

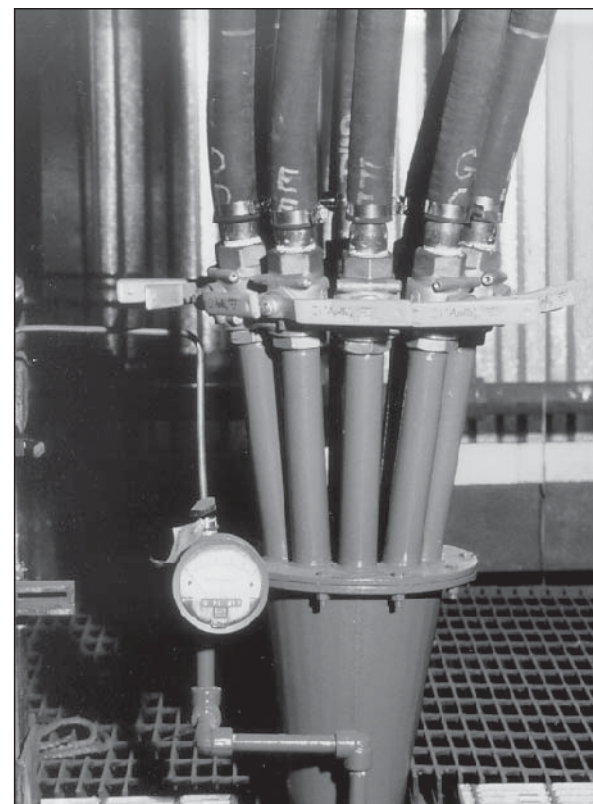

The flexible lime-sorbent distribution lines lead from the sorbent splitter to the top of the cyclone-fired boiler at Lakeside Station.

Operational Performance (Hennepin/Lakeside)

Sorbent injection increased the frequency of sootblower operation but did not adversely affect boiler efficiency or equipment performance. Gas reburning decreased boiler efficiency by approximately 1.0% because of the increase in moisture formed with combustion of natural gas. Examination of the boiler before and after testing showed no measurable change in tube wear or metallurgy. Essentially, the scheduled life of the boiler was not compromised.

The ESPs adequately accommodated the changes in ash loading and resistivity with the presence of sorbent in the ash. No adverse conditions were found to exist. But as

mentioned, humidification was added at Hennepin to achieve acceptable ESP performance with GR-SI.

Economic Performance (Hennepin/Lakeside)

Capital and operating costs depend largely on site-specific factors, such as gas availability at the site, coal/gas cost differential, SO₂ removal requirements, and value of SO₂ allowances. It was estimated that for most installations, a 15% gas heat input will achieve a 60% NO_x reduction. The capital cost for such a GR installation was estimated at \$15/kW for 100-MWe and larger plants plus the cost of the gas pipeline (if required) (1996\$). Operating costs were almost entirely related to the differential cost of the gas over the coal as reduced by the value of SO₂ emission allowances.

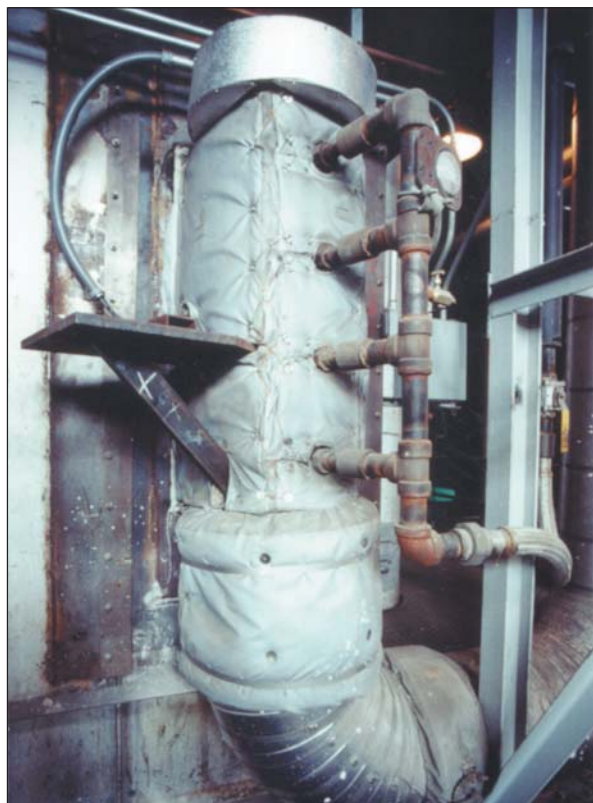

The natural gas injector was installed on the corner of Hennepin Station's tangentially fired boiler.

The capital cost estimate for SI was \$50/kW. Operating costs for SI were dominated by the cost of the sorbent and sorbent/ash disposal costs. SI was projected to be cost competitive at \$300/ton of SO₂ removed.

Commercial Applications

The GR-SI process is a unique combination of two separate technologies. The commercial applications for these technologies, both separately and combined, extend to both utility companies and industry in the United States and abroad. In the United States alone, these two technologies can be applied to more than 900 pre-NSPS utility boilers. The technologies also can be applied to new utility boilers. With NO_x and SO₂ removal exceeding 60% and 50%, respectively, these technologies have the potential to extend the life of a boiler or power plant and also provide a way to use higher sulfur coals.

Illinois Power has retained the gas-reburning system and City Water, Light & Power has retained the full technology for commercial use. The project was one of two receiving the Air and Waste Management Association's 1997 J. Deane Sensenbaugh Award.

Contacts

Blair A. Folsom, Senior V.P., (949) 859-8851, ext. 140
General Electric Energy and Environmental Research Corporation
18 Mason
Irvine, CA 92618
blair.folsom@ps.ge.com
(949) 859-3194 (fax)

Victor K. Der, DOE/HQ, (301) 903-2700
victor.der@hq.doe.gov

Jerry L. Hebb, NETL, (412) 386-6079
hebb@netl.doe.gov

References

Enhancing the Use of Coals by Gas Reburning and Sorbent Injection; Volume 1—Program Overview. February 1997.

Enhancing the Use of Coals by Gas Reburning—Sorbent Injection: Volume 4: Gas Reburning Sorbent Injection at Lakeside Unit 7, City Water, Light and Power, Springfield, Illinois. Final Report. Energy and Environmental

Research Corporation. March 1996. Report No. DOE/PC/79796-T48-Vol.4. (Available from NTIS as DE96011869.)

Enhancing the Use of Coals by Gas Reburning—Sorbent Injection; Long Term Testing Period, September 1, 1991—January 15, 1993. Report No. DOE/PC/79796-T40.

Energy and Environmental Research Corporation. February 1995. (Available from NTIS as DE95011481.)

Enhancing the Use of Coals by Gas Reburning and Sorbent Injection; Volume 2: Gas Reburning—Sorbent Injection at Hennepin Unit 1, Illinois Power Company. Report No. DOE/PC/79796-T38-Vol. 2. Energy and Environmental Research Corporation. October 1994. (Available from NTIS as DE95009448.)

Enhancing the Use of Coals by Gas Reburning and Sorbent Injection; Volume 3: Gas Reburning—Sorbent Injection at Edwards Unit 1, Central Illinois Light Company. Report No. DOE/PC/79796-T38-Vol. 3. Energy and Environmental Research Corporation. October 1994. (Available from NTIS as DE95009447.)

Milliken Clean Coal Technology Demonstration Project

Project completed

Participant

New York State Electric & Gas Corporation (NYSEG)

Additional Team Members

New York State Energy Research and Development Authority—cofunder

Empire State Electric Energy Research Corporation—cofunder

Consolidation Coal Company—technical consultant
 Saarberg-Hölter Umwelttechnik, GmbH (S-H-U)—technology supplier

The Stebbins Engineering and Manufacturing Company—technology supplier

ABB Air Preheater, Inc.—technology supplier

Electric Power Research Institute—cofunder

Location

Lansing, Tompkins County, NY (NYSEG's Milliken Station, Unit Nos. 1 and 2). This station is currently owned by AES Corporation and is designated AES Cayuga.

Technology

Flue gas cleanup using S-H-U formic-acid-enhanced, wet limestone scrubber technology; ABB Combustion Engineering's Low-NO_x Concentric Firing System (LNCFS™) Level III; Stebbins' tile-lined, split-module absorber; ABB Air Preheater's heat-pipe air preheater; and NYSEG's PEOA Control System.

Plant Capacity/Production

300 MWe

LNCFS is a trademark of ABB Combustion Engineering, Inc. PEOA is a trademark of DHR Technologies, Inc.

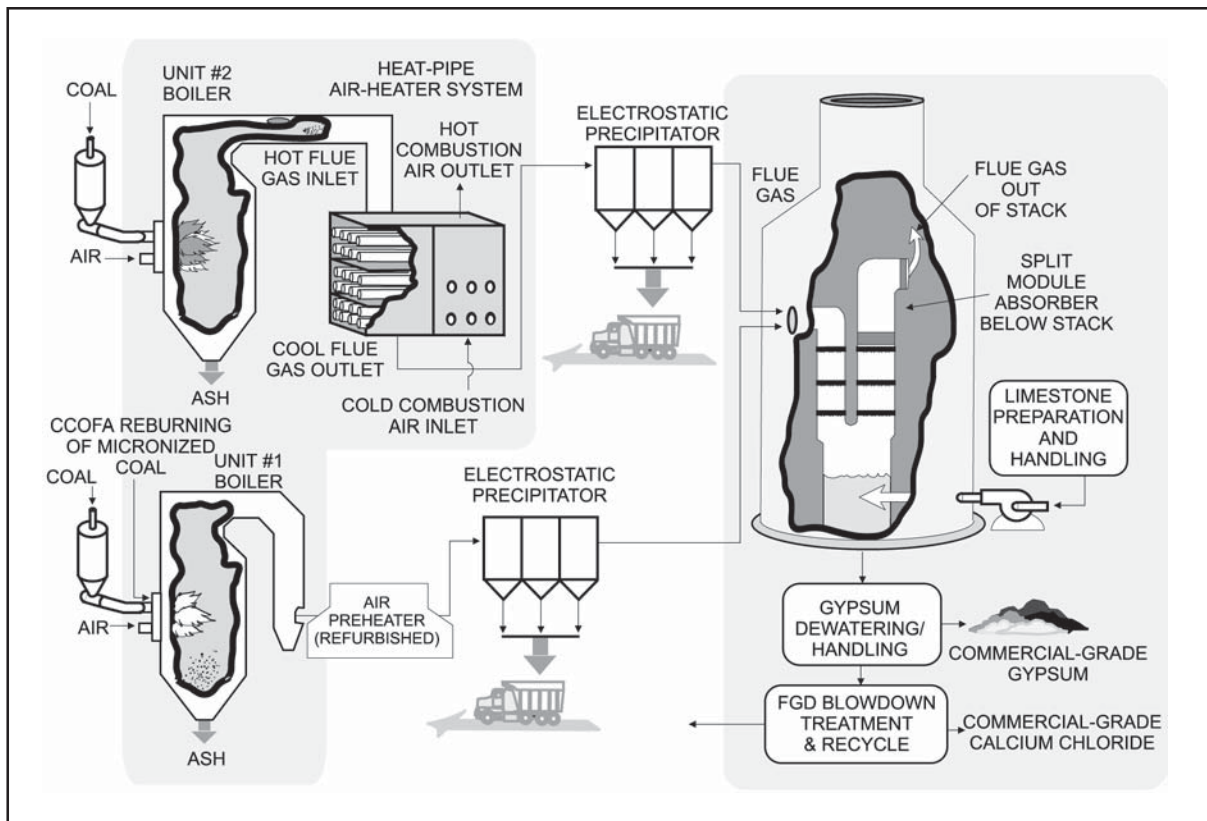

Coal

Pittsburgh, Freeport, and Kittanning Coals; 1.5, 2.9 and 4.0% sulfur, respectively.

Project Funding

Total	\$158,607,807	100%
DOE	45,000,000	28
Participant	113,607,807	72

Project Objective

To demonstrate high sulfur capture efficiency and NO_x and particulate control at minimum power requirements, zero waste water discharge, and the production of by-products in lieu of wastes.

Technology/Project Description

The formic acid enhanced S-H-U process is designed to remove up to 98% of SO₂ at high sorbent utilization rates. The Stebbins tile-lined, split-module reinforced concrete absorber vessel provides superior corrosion and abrasion resistance. Placement below the stack saves space and provides operational flexibility. NO_x emissions are controlled by LNCFS III™ low-NO_x burners. A heat-pipe air preheater is integrated to increase boiler efficiency by reducing both air leakage and the air preheater's flue gas exit temperature. To enhance boiler efficiency and emissions reductions, a Plant Emission Optimization Advisor (PEOA) provides state-of-the-art, artificial-intelligence-based control of key boiler and plant operating parameters. (See Micronized Coal Reburning Demonstration for NO_x Control for another CCT Program project at this unit.)

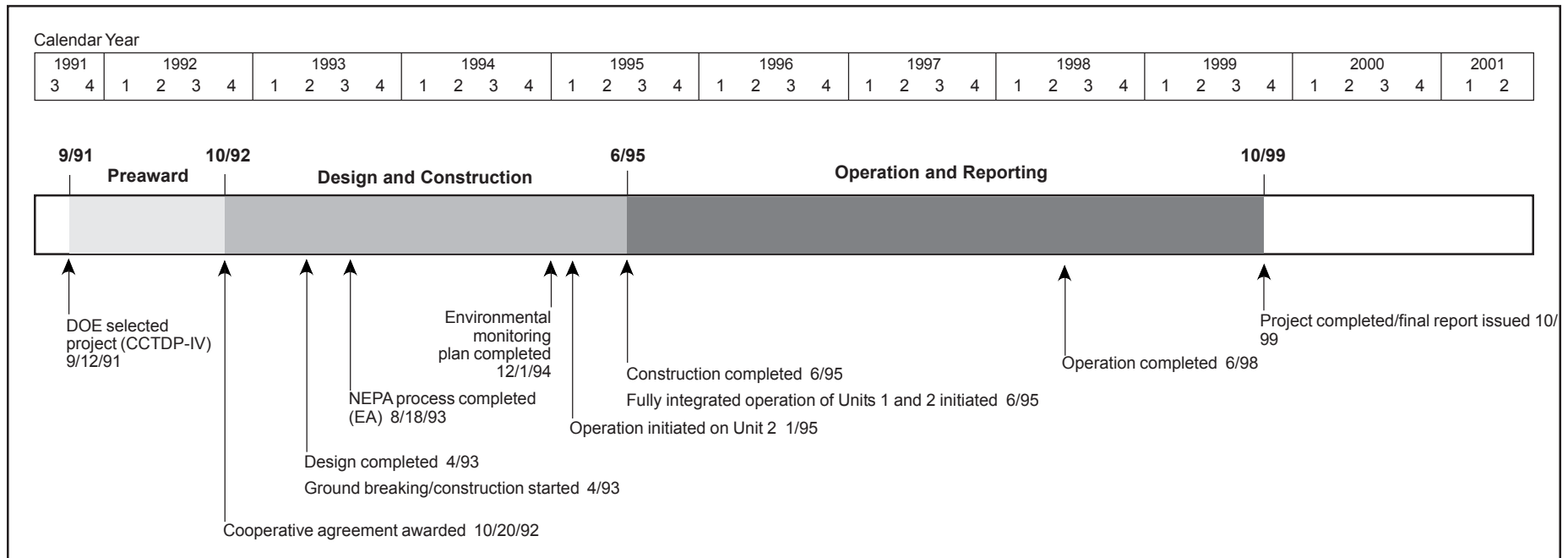

Results Summary

Environmental

- The maximum SO₂ removal demonstrated was 98% with all seven recycle pumps operating and using formic acid. The maximum SO₂ removal without formic acid was 95%.
- The difference in SO₂ removal between the two limestone grind sizes tested (90%–325 mesh and 90%–170 mesh) while using low-sulfur coal was an average of 2.6 percentage points.
- The SO₂ removal efficiency was greater than the design efficiency during the high-velocity test of the concurrent scrubber section up to a liquid-to-gas ratio (L/G) of 110 gallons per 1,000 actual cubic feet (kacf) of gas.
- At full load, LNCFS™ III lowered NO_x emissions to 0.39 lb/10⁶ Btu (compared to 0.64 lb/10⁶ Btu for the original burners)—a 39% reduction.
- LNCFS™ III maintained carbon in the fly ash below 4% and carbon monoxide emissions at baseline levels.

Operational

- For more than 30,000 hours, the S-H-U FGD unit demonstrated nearly 100% availability at capacity factors of 70–80%.
- The Stebbins tile-lined absorber demonstrated superior corrosion and abrasion resistance.
- The heat-pipe air preheater reduced power requirements by an average of 778 kW.
- Performance of a modified ESP with wider plate spacing and reduced plate area exceeded that of the original ESPs at lower power consumption.
- Boiler efficiency was essentially unchanged by the application of LNCFS™ III.
- Boiler efficiency was 88.3–88.5% for LNCFS™ III, compared to a baseline of 89.3–89.6%.

Economic

- The capital cost (1998\$) of the FGD system is estimated at \$300/kW for a 300-MWe unit with a 65% capacity factor, 3.2% sulfur coal, and 95% sulfur removal.

- The annual FGD operating cost is estimated at \$4.62 million (1998\$); and the 15-year levelized cost is estimated at \$412/ton of SO₂ removed (constant 1998\$).

Project Summary

The S-H-U FGD unit at the Milliken Plant operated for more than 30,000 hours during the demonstration with nearly 100% availability and 90–95% SO₂ removal. Combined with LNCFS™ III low-NO_x burners which reduced NO_x emissions by 39%, the demonstrated system offers an effective option for controlling both SO₂ and NO_x for over 400 U.S. pulverized coal, tangentially fired units.

The test plan used in this demonstration was developed to cover all of the new technologies used in the project. In addition to the technologies tested, the project demonstrated that existing technologies can be used in conjunction with new processes to produce salable by-products. Generally, each test program was divided into four independent subtests: diagnostic, performance, long-term, and validation.

Environmental Performance

FGD Performance. An overall assessment of the S-H-U process is that it performed well in tests burning low- (1.6%), design- (2.2%), and high-(3.2–4.1%) sulfur (S) coals. The maximum SO₂ removal demonstrated was 98% with all seven recycle pumps operating and using formic acid, and the maximum SO₂ removal without formic acid was 95%. The unit operated routinely in the 90–95% SO₂ removal range.

Design-Sulfur Coal (2.2% S). Availability of design coal and time constraints truncated design coal testing. But, testing did show that the L/G ratio is an important variable for SO₂ removal. The SO₂ removal efficiency ranged from 85.6% with five spray headers in service to 95.1% with all seven spray headers in service, while using a nominal 800 parts per million (ppm) formic acid concentration, a limestone grind of 90% passing through 170 mesh, and a gas velocity rate of 20 feet per second (ft/s) in the cocurrent section. More SO₂ removal was achieved when a higher percentage of the total slurry was sprayed in the countercurrent section. A single test indicated the importance of pH. The SO₂ removal rates ranged from 91.5% at a normal pH of 4.1 ± 0.1 to 85.4% at a lowered pH of 3.9, with all other operating conditions the same.

Low-Sulfur Coal (1.6% S). A shortened demonstration period and availability problems with design coal resulted

in most testing being performed on the low-sulfur coal. Parametric tests were performed on the full range of variables. The number of spray headers in service impacted SO₂ removal efficiency. The SO₂ removal rate ranged from a low of 30% using only two spray headers without formic acid to 98% using all seven spray headers and 800 ppm of formic acid. The maximum SO₂ removal was 98% at a 95% confidence level of ± 0.7%.

The SO₂ removal efficiency was increased significantly with the addition of formic acid. With five spray headers in service, SO₂ removal efficiency increased from 82% without formic acid to 97% with 800 ppm of formic acid added. Formic acid effects diminished with increasing concentration. Also, the pH of the spray slurry affected SO₂ removal efficiency. Increasing the pH from 4.2 to 5.0 without formic acid additive increased SO₂ removal efficiency an average of 10.1 percentage points.

High-Sulfur Coal (3.2–4.1% S). Both time constraints and slurry pump capacity limited high-sulfur coal testing. Nevertheless, certain conclusions were reached as a result of those tests. As expected, sulfur removal efficiency decreased as the coal sulfur content increased. The SO₂ removal efficiency depended more on the system pH than the L/G ratio. Indications were that an S-H-U with higher slurry pump capacity would perform at high SO₂ removal efficiencies using high sulfur coals.

Nine tests were performed using an alternative limestone grind size. Higher SO₂ removal resulted using the finer grind (90% passing through 325 mesh) limestone in lieu of the coarser grind (90% passing through 170 mesh). The average difference in SO₂ removal between the two grind sizes was 2.6 percentage points, as shown in Exhibit 3-40.

Low-NO_x Burner Performance. At full boiler load (145–150 MWe) and 3.0–3.5% economizer oxygen (O₂), the LNCFS™ III system lowered NO_x emissions from a baseline value of 0.64 lb/10⁶ Btu to 0.39 lb/10⁶ Btu, a 39% reduction. At a reduced boiler load of 80–90 MWe and 4.3–5.0% economizer O₂, the LNCFS™ III system lowered NO_x emissions

from a baseline value of 0.58 lb/10⁶ Btu to 0.41 lb/10⁶ Btu, a 29% reduction. Carbon in the fly ash was maintained below 4% and carbon monoxide emissions did not increase.

ESP Performance. Performance of the modified ESP with wider plate spacing (16 inches), less than half the plate area, and reduced power consumption, exceeded that of the original ESP. The average particulate matter penetration before the ESP modification was 0.22%. This decreased to 0.12% after the modification.

Air Toxics. Comprehensive air toxics emissions and characterization testing was carried out during the Milliken demonstration. In summary, the ESP and FGD combined to remove 99.81% of trace elements found primarily in the solid phase, with the ESP averaging 99.7% removal. The ESP removed 99.96% of the major ash elements. The ESP removal efficiency for mercury was 16.7% and the FGD removal efficiency was 59.8%.

Operational Performance

The demonstrated technologies are still in service at the Milliken Plant with the exception of the brine concentrating system, which suffered from technical difficulties. The gypsum and fly ash byproducts continue to be marketed.

Exhibit 3-40
Effect of Limestone Grind

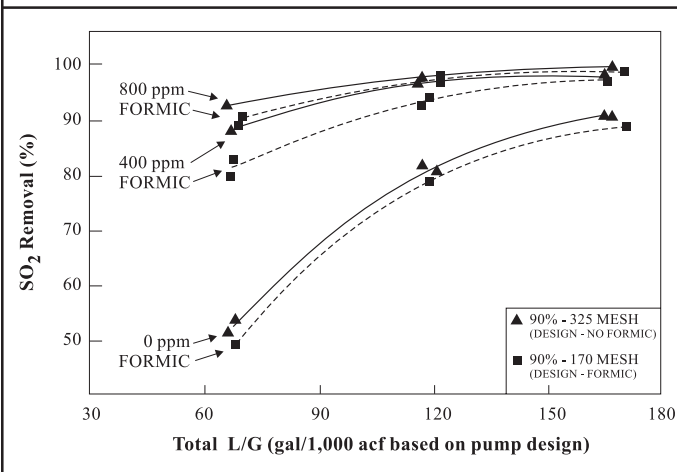

FGD Performance. For more than 30,000 hours of demonstration operation, the S-H-U FGD unit reliability was high and availability held at nearly 100% at capacity factors of 70–80%. Unit thermal efficiencies hovered around 35%. However, some initial problems had to be overcome and the demonstration identified some areas to improve performance in future applications.

Plugging of the slurry spray nozzles and hydrocyclone elements with rubber coming off the rubber-clad turning vanes and gypsum deposits resulting from insufficient seed crystals in the absorber slurry tank was solved by installing screens at the slurry pump intakes and keeping gypsum levels up in the absorber reaction tank. Mixing in the slurry tank was problematic and resulted in continuous operation of the slurry pumps to alleviate the problem, albeit at higher power requirements.

The expected high limestone utilization, due to formic acid-enabled low pH, was somewhat compromised by the relatively close proximity of the limestone injection and gypsum bleed pump suction ports, causing some limestone to be drawn off with the gypsum. Poor mixing in the absorber tank exacerbated the situation. The problem was largely resolved by moving the limestone injection port further into the tank. But, wider separation is warranted in future designs.

The Stebbins split-module, tile-lined absorber demonstrated superior abrasion and corrosion resistance, suggesting a liner life three to four times that of rubber liners. The construction allowed installation beneath the stack to save space and the configuration allowed flexibility in operation and maintenance (one unit can be shut down for low load situations or for on-line repairs).

Low-NO_x Burner Performance. Boiler efficiency was 88.3–88.5% using LNCFS™ III, compared to a baseline of 89.3–89.6%. The lower boiler efficiency was attributed to higher post-retrofit flue gas O₂ levels and higher stack temperatures, which accompanied the air preheater retrofit. The LNCFS™ III and baseline results were adjusted so that they could be compared at similar flue gas temperatures. Under comparable conditions, the LNCFS™ III boiler efficiency was estimated to be 0.2 of a percentage point higher than baseline.

Heat Pipe Air Preheater. An expected thermal efficiency boost from applying the heat pipe principle did not materialize (a 20 °F reduction in flue gas exit temperature was projected), but an overall efficiency gain resulted from reduced leakage. Fan power savings averaged 778 kW, or about 0.49% of gross load. Pressure losses across flue gas and air sides were less than the design values of 3.65 inches of water and 5.35 inches of water, respectively.

ESP. Performance tests on the original and modified ESPs showed that the modified ESP had better removal efficiency, as discussed previously, even though it had one-half of the collection plate area of the original ESP. The data show that the power requirement is 25% less than that of the original ESP.

POEA™. The POEA™ control system is an online support system designed to help meet economic performance targets by integrating key information and analyses that assist plant personnel in optimizing plant performance, including steam and waste management systems. Although not necessary for S-H-U operation, the promise of POEA™ is that it will compensate for parasitic power losses. Due to data collection problems, the two tests on the POEA™ system were promising, but inconclusive.

CAPCIS. NYSEG installed and tested an online, real-time corrosion monitoring system to identify the lowest flue gas outlet temperature possible without compromising equipment subject to corrosion. Probes were placed at the heat pipe air preheater outlet and S-H-U FGD inlet duct. Software was to use probe signals to control the secondary air bypass damper in the heat pipe preheater. At the time of the project final report, the data was insufficient to draw any conclusions on the system.

Economic Performance

The estimated capital cost of the total FGD system in 1998 dollars was estimated at \$300/kW for a 300-MWe unit with a 65% capacity factor using 3.2% sulfur coal and achieving 95% sulfur removal. The annual operating cost is estimated at \$4.62 million. The 15-year levelized cost is estimated at \$412/ton of SO₂ removed in 1998 constant dollars. On a unit cost basis, total capital requirements for an S-H-U FGD retrofit similar to Milliken Station can be expected to range from \$385/kW for a 150-MW plant to \$260/kW for a 500-MW plant.

Commercial Applications

The S-H-U process, Stebbins absorber module, and heat-pipe air preheater are applicable to virtually all coal-fired power plants. In a NYSEG analysis, the total U.S. electric market for which the S-H-U process was applicable was divided into two parts: retrofit capacity (pre-NSPS coal-fired boilers not equipped with SO₂ controls) and new capacity (projected coal-fired additions through 2030). This analysis suggests a total potential retrofit market of 5,700 MWe through 2030 and a potential new power plant market of 96,200 MWe. Although done in 1995, this analysis remains reasonably accurate. The LNCFS™ system has the potential commercial application to over 400 U.S. pulverized coal, tangentially fired utility units. These units range from 25 MWe to 950 MWe in size and burn a wide range of coals, from low-volatile bituminous to lignite.

Contacts

Jim Harvilla, Project Manager, (607) 762-8630
New York State Electric & Gas Corporation
Corporate Drive—Kirkwood Industrial Park
P.O. Box 5224
Binghamton, NY 13902-5224
jjharvilla@nyseg.com
(607) 762-4002 (fax)

Victor K. Der, DOE/HQ, (301) 903-2700
victor.der@hq.doe.gov

Thomas A. Sarkus, NETL, (412) 386-5981
sarkus@netl.doe.gov

References

Milliken Clean Coal Technology Demonstration Project: Project Performance and Economics Report, Final Report Volumes I & II. New York State Electric & Gas Corporation. October 1999.

Comprehensive Report to Congress on the Clean Coal Technology Program: Milliken Clean Coal Technology Demonstration Project. New York State Electric & Gas Corporation. Report No. DOE/FE-0265P. U.S. Department of Energy. September 1992. (Available from NTIS as DE93001756.)

Milliken Clean Coal Technology Demonstration Project—Project Performance Summary. U.S. Department of Energy. November 2002.

Integrated Dry NO_x/SO₂ Emissions Control System

Project completed

Participant

Public Service Company of Colorado

Additional Team Members

Electric Power Research Institute—cofunder

Stone and Webster Engineering Corp.—engineer

The Babcock & Wilcox Company—burner developer

Fossil Energy Research Corporation—operational tester

Western Research Institute—fly ash evaluator

Colorado School of Mines—bench-scale engineering researcher and tester

NOELL, Inc.—urea injection system provider

Location

Denver, Denver County, CO (Public Service Company of Colorado’s Arapahoe Station, Unit No. 4)

Technology

The Babcock & Wilcox Company’s DRB-XCL® low-NO_x burners (LNB) with overfire air (OFA), in-duct dry sorbent injection (DSI) with and without flue gas humidification (FGH), and NOELL’s urea-based selective non-catalytic reduction (SNCR) injection

Plant Capacity/Production

100 MWe

Coal

Colorado bituminous, 0.4% sulfur

Wyoming subbituminous (short test), 0.35% sulfur

Project Funding

Total	\$26,165,306	100%
DOE	13,082,653	50
Participant	13,082,653	50

DRB-XCL is a registered trademark of The Babcock & Wilcox Company.

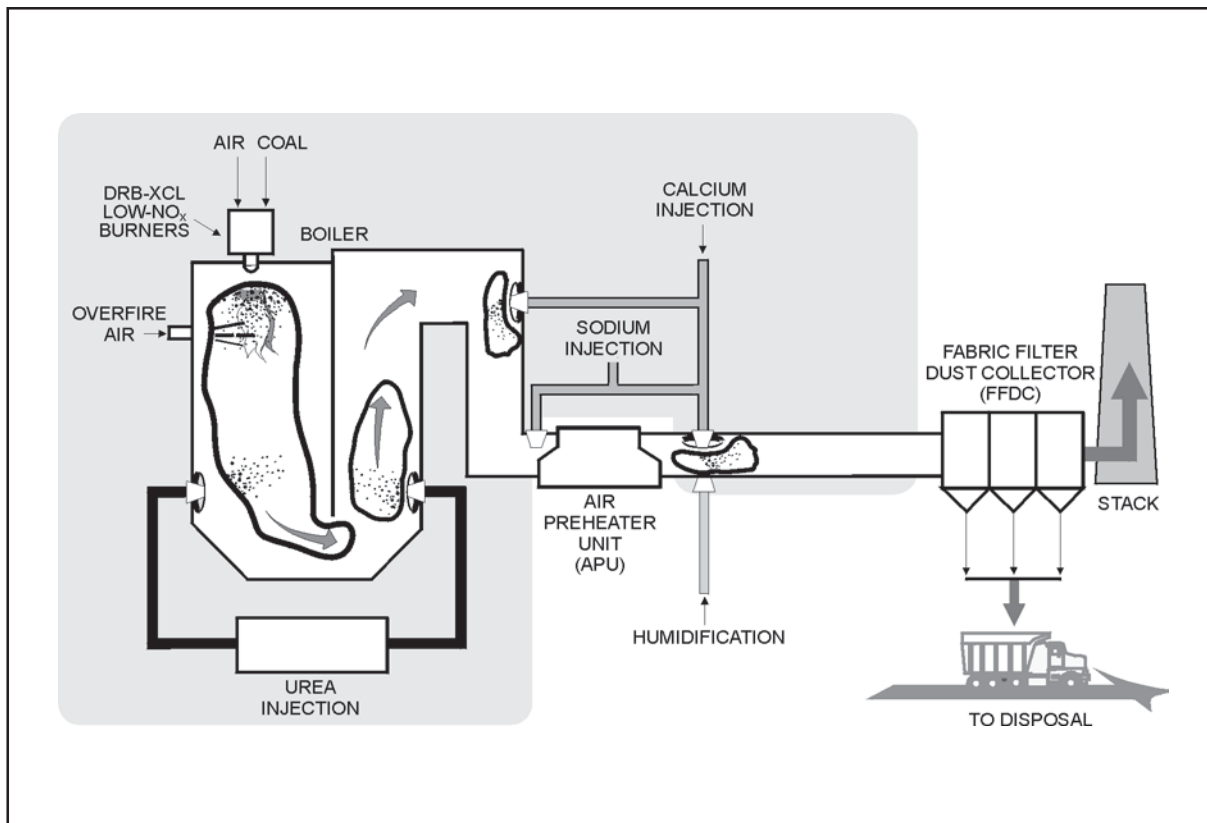

Project Objective

To demonstrate the integration of five technologies (LNB, OFA, DSI, FGH, and SNCR) to achieve up to 70% reduction in NO_x and SO₂ emissions; more specifically, to assess the integration of a down-fired, low-NO_x burner with in-furnace urea injection for additional NO_x removal and dry sorbent in-duct injection with humidification for SO₂ removal.

Technology/Project Description

All of the testing used Babcock & Wilcox’s low-NO_x DRB-XCL® down-fired burners with overfire air (12 DRB-XCL® burners and 6 B&W Dual-Zone NO_x ports). These burners control NO_x by injecting the coal and the combustion air in an oxygen-deficient environment. Additional air is introduced via overfire air ports to complete the combustion process and further enhance NO_x removal. A urea-

based SNCR system was tested to determine how much additional NO_x can be removed from the combustion gas.

Two types of dry sorbents were injected into the ductwork downstream of the boiler to reduce SO₂ emissions. Either calcium-based sorbent was injected upstream of the economizer, or sodium-based sorbent downstream of the air heater. Humidification downstream of the dry sorbent injection was incorporated to aid SO₂ capture and lower flue gas temperature and gas flow before entering the fabric filter dust collector (FFDC).

The Integrated Dry NO_x/SO₂ Emissions Control System (IDECS) was installed on Public Service Company of Colorado’s Arapahoe Station Unit No. 4, a 100-MWe down-fired, pulverized-coal boiler with roof-mounted burners.

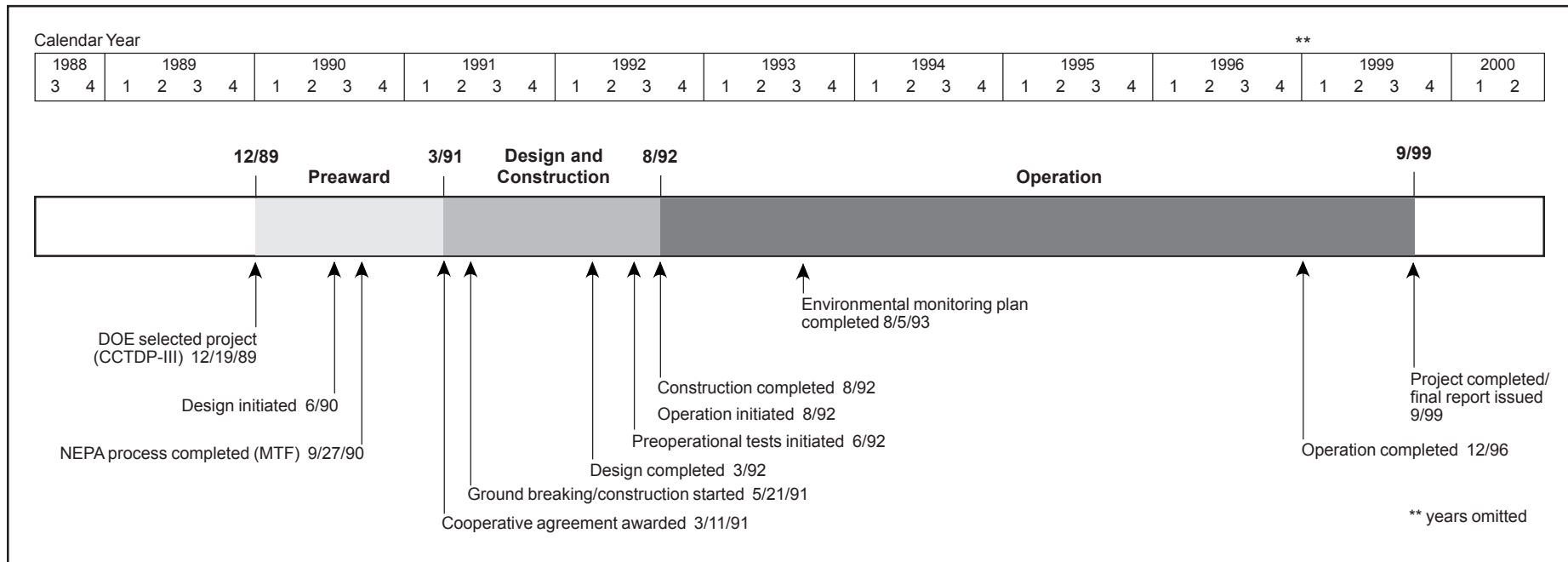

Results Summary

Environmental

- DRB-XCL[®] burners with minimum OFA reduced NO_x emissions by more than 61% over the load range of 80–100 MWe. With maximum OFA (32% of total secondary air at 50 MWe to 24% at 80 MWe and above), NO_x reduction was 62–69% across the load range of 50- to 110-MWe.
- DRB-XCL[®] burners with maximum OFA maintained CO below baseline emission levels, reaching a maximum of 50 ppm.
- The SNCR system, using both stationary and retractable injection lances in the furnace, provided NO_x removal of 30–50% at an ammonia (NH₃) slip of 10 parts per million (ppm), thus increasing performance of the total NO_x control system to greater than 80% NO_x reduction. The advanced retractable injection lances (ARIL) system increased NO_x emission reduction at low loads (below 70 MWe) from 11% to 35–52%.

- Hydrated lime injection into the boiler economizer at 950–1,150 °F reduced SO₂ emissions by 5–10%; and hydrated lime injection into the FFDC duct reduced SO₂ emissions by 28–40% at a normalized stoichiometric ratio (NSR) of 2.0 and 25–30 °F approach to saturation temperature.
- A 70% SO₂ removal was achieved by injecting sodium bicarbonate before the AP (650 °F) at an NSR of 1.0; and by injecting sodium sesquicarbonate after the APU (220–280 °F) at an NSR of 1.9.
- At 70% SO₂ removal, both sodium-based sorbents reduced NO_x emissions by approximately 10%.
- Integration of SNCR and sodium-based DSI decreased the level of unwanted nitrogen dioxide emissions by 50% and, in turn, DSI decreased the level of ammonia slip that would occur with SNCR alone.
- IDECS with the FFDC successfully removed 96.9–98.6% of trace metal emissions and 67.5–93.7% of the mercury.

Operational

- LNB/OFA maintained unburned carbon or loss-on-ignition (LOI) at essentially baseline levels.
- DRB-XCL[®] burners resulted in an approximately 200 °F decrease in furnace exit gas temperature, which impacted the amount of excess air required to maintain steam temperature at reduced load.
- Temperature differential between the top and bottom surfaces of the ARIL caused the lances to bend downward 12–18 inches, making insertion and removal difficult.

Economic

- Total estimated capital cost for IDECS applied to a 100-MWe boiler is \$195/kW. Fixed operating costs are estimated at \$0.32 million/year and variable operating costs at \$1.49 million/year.
- Estimated levelized costs are \$1,358/ton of NO_x plus SO₂ or 9.7 mills/kWh (current 1994\$) and \$1,044/ton of NO_x plus SO₂ or 7.4 mills/kWh (constant 1994\$).

Project Summary

ID ECS was composed of five technologies: LNBs, OFA, SNCR, DSI, and FGH. However, the combinations of the five separate technologies equated to three separate emission control systems for purposes of testing because the LNBs were always used in conjunction with OFA, and FGH was used only with DSI. The three systems—LNB/OFA, SNCR, and DSI with or without FGH—were individually tested using both parametric tests and long-term tests. Individual system tests were followed by testing the technologies as one integrated system.

Environmental Performance

LNB/OFA. The testing of the LNB/OFA system was performed in two phases, parametric testing and long-term testing. The results of LNB/OFA parametric testing are shown in Exhibit 3-41. Parametric testing was conducted with minimum OFA and maximum OFA. Minimum OFA represents 15% of total secondary air. Maximum OFA varies as boiler load, air flow, and fan pressure change. Maximum OFA varied from 32% of total secondary air at a load of 50 MWe to 24% at 80 MWe and above. The LNB/OFA system using minimum OFA reduced NO_x emissions from 61–64% in the 80–100 MWe load range. At maximum OFA, the LNB/OFA system reduced NO_x emissions 61–69% in the 50–100 MWe load range. Maximum OFA kept CO levels lower than the original burners, holding CO levels to a maximum of 50 ppm, as shown in Exhibit 3-42. However, the LNBs required higher than baseline excess air to maintain adequate steam temperature and to stay below 50 ppm CO at boiler loads below 100 MWe.

During long-term testing, the NO_x emissions were 10–20% (30–60 ppm) higher than the parametric tests. These increased NO_x emissions were attributed to higher oxygen (O_2) levels (1.0–1.5% higher) experienced during normal load-following conditions. The NO_x levels increased by about 40 ppm for each % increase in O_2 levels.

SNCR. The SNCR system underwent both parametric and long-term testing. Boiler load was the predominant factor in determining the flue gas temperature at SNCR injection locations and, therefore, had the greatest effect on performance. The original two-row SNCR injector design proved relatively ineffective because one row was in a region where the flue gas temperature was too low for effective operation.

This situation was exacerbated by a 200 °F boiler temperature drop resulting from LNB/OFA installation. Thus, installation of the ARIL retractable lance system in the appropriate temperature region was required to bring SNCR performance to an acceptable level. With the ARIL system, NO_x reduction increased from 11% to 35–52% at loads below 70 MWe. The ability to follow the temperature window by rotating the lances proved to be an important feature in optimizing performance. As a result, the SNCR system achieved NO_x removals of 30–50% (at an ammonia slip limited to 10 ppm at the FFDC inlet) over the normal load range. The 30–50% reduction was with LNB/OFA and resulted in total NO_x emission reductions of greater than 80%.

DSI/FGH. DSI testing examined two sodium-based sorbents (sodium-sesquicarbonate and sodium-bicarbonate) and hydrated lime. Objectives of the sodium-based DSI test extended beyond SO_2 removal to evaluating the effects on NO_x removal and NO_2 emissions. Variables investigated included sorbent type, boiler load, injection

location, sorbent particle size, humidification/approach-to-saturation temperature, and NSR. NSR is a molar ratio of sorbent to SO_2 that has a value of 1.0 for the theoretical removal of all SO_2 . For calcium-based sorbents only 1.0 mole of calcium is needed to remove 1.0 mole of sulfur, whereas 2.0 moles of sodium are needed. Percent utilization is the ratio of percent SO_2 removal divided by NSR.

Boiler load had little, if any, effect on SO_2 removal. SO_2 removals of 70% were achieved with sodium-bicarbonate at an NSR of 1.0, while sodium-sesquicarbonate required an NSR of 1.9 for the same removal efficiency. The sodium-bicarbonate was injected before the air preheater unit (APU) at 650 °F to correct for slow response times in reaching steady-state conditions. The sodium-sesquicarbonate was injected after the APU at 220–280 °F, but had equal effect when injected before the APU.

Particle size proved to be a major factor influencing SO_2 removal efficiency for sodium-sesquicarbonate, ranging from 28% at a 28 microns mean particle diameter to 48%

Exhibit 3-41
Boiler Load Parametric Testing
of LNB/OFA System

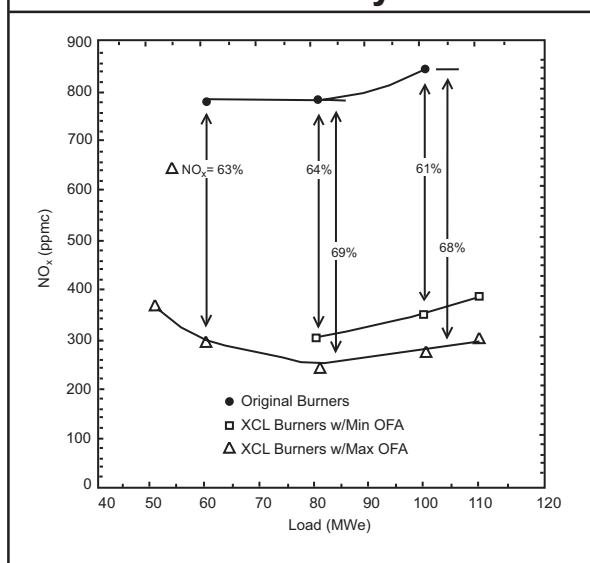
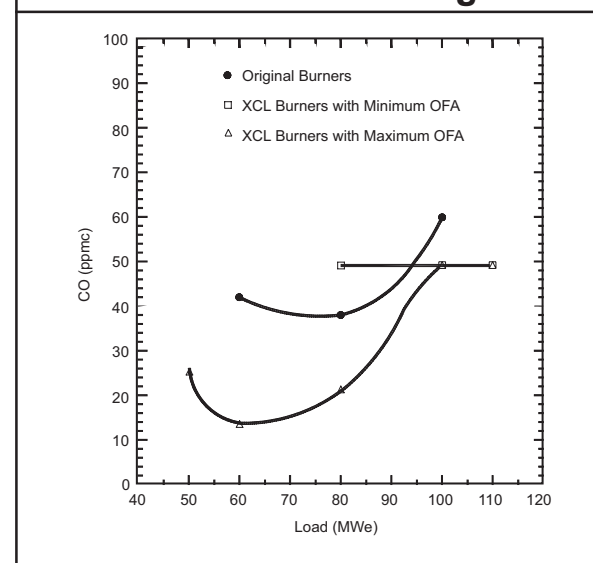

Exhibit 3-42
CO Emissions During
Parametric Testing



at 15 microns (both measurements at an NSR of 0.9). The SO₂ removal efficiency with sodium-bicarbonate showed less dependence on particle size. Humidification at a 60 °F approach-to-saturation temperature increased sodium-sesquicarbonate SO₂ removal efficiency by 20% at an NSR of 2.0, but had little effect at an NSR of 1.0.

Both sodium sorbents reduced NO_x emissions by approximately 10% at injection levels comparable to 70% SO₂ removal, but oxidized NO to NO₂. However, sodium-sesquicarbonate produces only half as much NO₂ as sodium-bicarbonate at comparable SO₂ removal efficiencies.

Hydrated lime achieved only 5–10% SO₂ removal when injected into the economizer at 950–1,150 °F and an NSR of 2.0. This performance was attributed in large part to poor sorbent distribution. Humidification failed to significantly improve the performance. Hydrated lime injection downstream of the APU at a 25–30 °F approach-to-saturation temperature and NSR of 2.0 achieved only 28–40% SO₂ removal, short of the 50% target.

SNCR/DSI Synergy. Operation of the SNCR with sodium-based DSI reduced the NO₂ emissions that occur with sodium-based DSI alone by approximately 50%. Sodium-based DSI reduces ammonia slip by an estimated 50% by inducing precipitation onto the fly ash. At 8 ppm NH₃ slip, fly ash NH₃ ranged from 400–700 ppm versus 100–200 ppm with SNCR alone. Adjusting NH₃ slip to 4 ppm returned fly ash NH₃ levels to 100–200 ppm.

Air Toxics. The IDECS project included a comprehensive investigation into many potential air toxics. Tests show that the use of a FFDC was very effective for controlling nearly all air toxic emissions. Overall particulate removal was greater than 99.9%, and trace metal emission removal ranged from 96.9–98.6%. Mercury removal across the FFDC was 67.5% with dry sodium-based DSI, 77.9%, with SNCR, and 93.7% with calcium-based DSI/FGH.

Operating Performance

The Arapahoe Unit No. 4 operated more than 34,000 hours with the combustion modifications in place. The availability factor during the period was over 91%.

LNB/OFA. The new LNBs resulted in an approximately 200 °F decrease in furnace exit temperature, which required more excess air than baseline to maintain steam

temperature at low loads. The LOI essentially remained the same between the new and original burners, except at 50 MWe. High LOI at this low load was attributed to an uneven distribution of coal and a coarser grind as the number of mills in service dropped from three to two.

SNCR. The ARIL lances proved to be effective NO_x control devices, but experienced some operational problems. A large differential heating pattern between opposite sides of the lance caused a differential in thermal expansion and bending of the lance approximately 12–18 inches, making insertion and retraction difficult. The problem was partially resolved by adding cooling slots at the end of the lance. An alternative design, provided by Diamond Power Specialty Company, was tested and found to have less bending due to evaporative cooling, but NO_x reduction and ammonia slip performance dropped relative to the ARIL system.

DSI/FGH. During the operation of the DSI system with hydrated lime and FGH under load-following conditions, the FFDC pressure drop significantly increased as a result of buildup of a hard ash cake on the fabric bags that could not be cleaned under normal reverse-air cleaning. The FGH system caused the heavy ash cake, but it was not determined whether the problem was due to operation at 30 °F approach-to-saturation temperature or an excursion caused by a rapid decrease in load.

When the SNCR and DSI systems were operated concurrently, an ammonia odor problem was encountered around the ash silo due to the rapid change in pH attributable to the presence of sodium in the ash and the wetting of the fly ash to minimize fugitive dust. This problem was resolved by transporting the ash in enclosed tanker trucks and by not adding water.

Economic Performance

The technology is an economical method of obtaining SO₂ and NO_x reduction on low-sulfur coal units. Total estimated capital costs range from 125–281 \$/kW (1994\$) for capacities ranging from 300–50 MWe. Comparably, wet scrubber and SCR capital costs range from 270–474 \$/kW for the same unit size range. On a levelized cost basis, the demonstrated system costs vary from 12.43–7.03 mills/kWh (1,746–987 \$/ton of SO₂ and NO_x removed) compared to wet scrubber and SCR levelized

costs of 23.34–12.67 mills/kWh (4,974–2,701 \$/ton of SO₂ and NO_x removed) based on 0.4% sulfur coal. The integrated system is most efficient on smaller low-sulfur coal units. As size and sulfur content increase, the cost advantages decrease.

Commercial Applications

The IDECS system was developed to meet the site-specific requirements of some of the more difficult boiler emission-control situations. A market analysis indicated that 65 down-fired boilers, totaling 6,400 MWe, and 29 wet bottom boilers, totaling 3,800 MWe, could be candidates for the IDECS system. Because of their age and design, these units generate high levels of NO_x and because of lack of plot area, they are difficult to retrofit. The plants also tend to be relatively small. As a result of these considerations, utilities will be reluctant to make major capital investments in these units. However, IDECS provides an economic alternative that can extend plant life.

Contacts

Terry Hunt, Production Engineer, (720) 497-2129

Xcel Energy
4653 Table Mountain Dr.
Golden, CO 80403
terry.hunt@xcelenergy.com
(720) 497-2123 (fax)

Victor K. Der, DOE/HQ, (301) 903-2700
victor.der@hq.doe.gov

Jerry L. Hebb, NETL, (412) 386-6079
hebb@netl.doe.gov

References

- Integrated Dry NO_x/SO₂ Emissions Control System. Final Report, Volume 1: Public Design.* Public Service Company of Colorado. November 1997.
- Integrated Dry NO_x/SO₂ Emissions Control System. Final Report, Volume 2: Project Performance and Economics.* Public Service Company of Colorado. September 1999.
- Integrated Dry NO_x/SO₂ Emissions Control System—A DOE Assessment.* U.S. Department of Energy. 2001.
- Integrated Dry NO_x/SO₂ Emissions Control System—Project Performance Summary.* U.S. Department of Energy. February 2003.

Advanced Electric Power Generation Fluidized-Bed Combustion

Tidd PFBC Demonstration Project

Project completed

Participant

The Ohio Power Company

Additional Team Members

American Electric Power Service Corporation—designer, constructor, and manager

The Babcock & Wilcox Company—technology supplier

Ohio Coal Development Office—cofunder

Location

Brilliant, Jefferson County, Ohio (Ohio Power Company's Tidd Plant, Unit No. 1)

Technology

The Babcock & Wilcox Company's pressurized fluidized-bed combustion (PFBC) system (under license from ABB Carbon)

Plant Capacity/Production

70 MWe (net)

Coal

Ohio bituminous, 2–4% sulfur

Project Funding

Total	\$189,886,339	100%
DOE	66,956,993	35
Participant	122,929,346	65

Project Objective

To verify expectations of PFBC economic, environmental, and technical performance in a combined-cycle repowering application at utility scale; and to accomplish greater than 90% SO₂ removal and NO_x emission level of 0.2 lb/10⁶ Btu at full load.

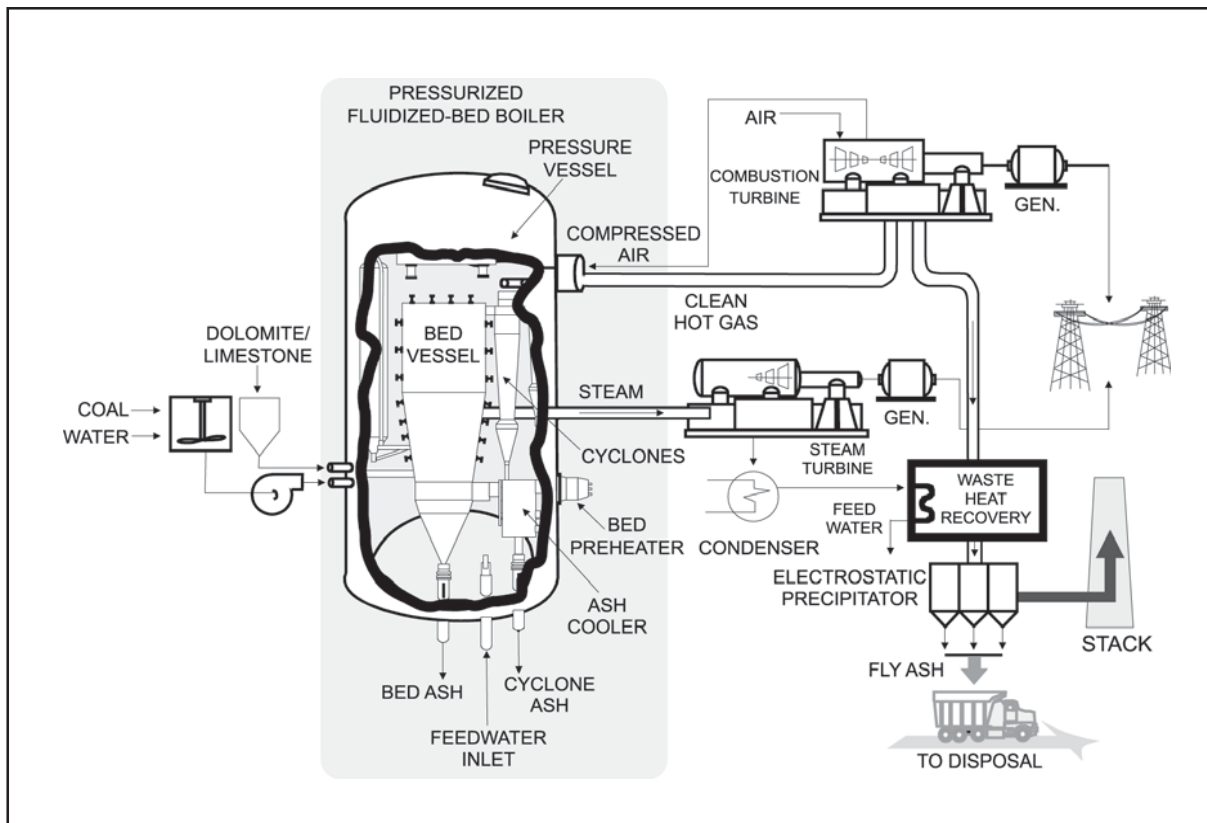

Technology/Project Description

Tidd was the first large-scale operational demonstration of PFBC in the United States. The project represented a 13:1 scaleup from the pilot facility.

The boiler, cyclones, bed reinjection vessels, and associated hardware were encapsulated in a pressure vessel 45 feet in diameter and 70 feet high. The facility was designed so that one-seventh of the hot gases produced could be routed to an advanced particulate filter (APF).

The Tidd facility used a bubbling fluidized-bed combustion process operating at 12 atm (175 psi). Pressurized combustion air is supplied by the turbine compressor to fluidize the bed material, which consists of a coal-water fuel paste, coal ash, and a dolomite or limestone sorbent. Dolomite or limestone in the bed reacts with sulfur to form calcium sulfate, a dry, granular bed-ash material, which is easily

disposed of or is usable as a by-product. A low bed temperature of about 1,600 °F limits NO_x formation.

The hot combustion gases exit the bed vessel with entrained ash particles, 98% of which are removed when the gases pass through cyclones. The cleaned gases are then expanded through a 15-MWe gas turbine. Heat from the gases exiting the turbine, combined with heat from a tube bundle in the fluid bed, generates steam to drive an existing 55-MWe steam turbine.

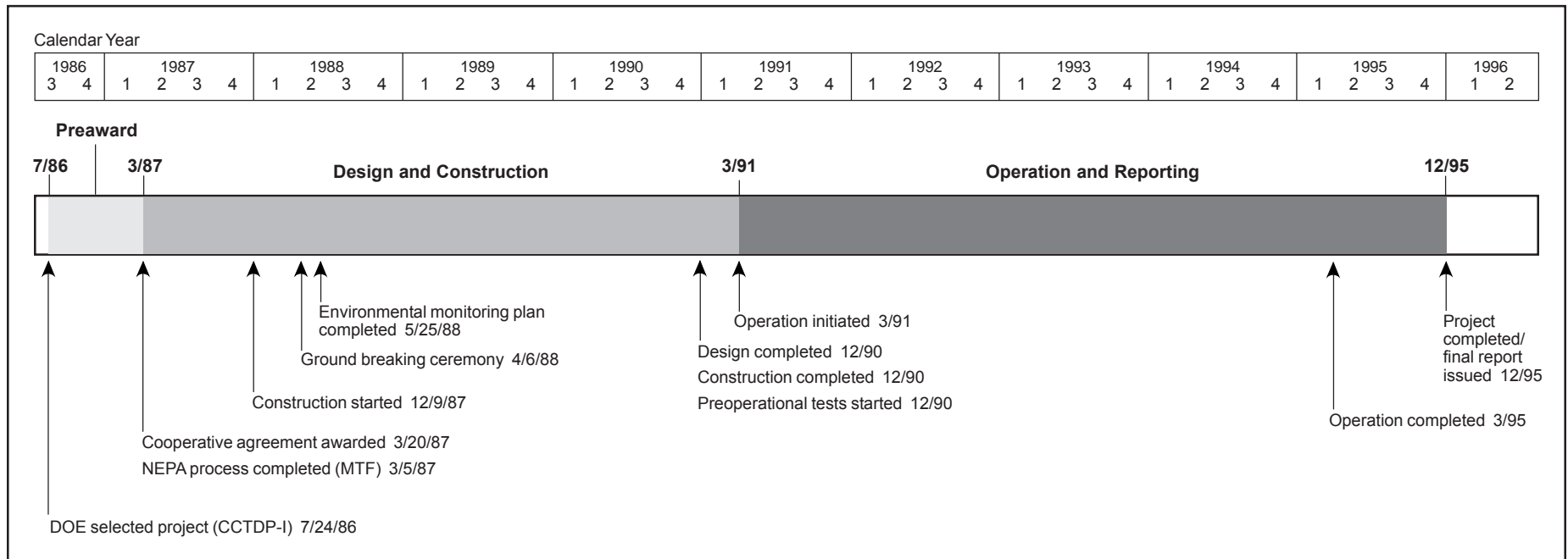

Results Summary

Environmental

- Sorbent size had the greatest effect on SO₂ removal efficiency as well as stabilization and heat transfer characteristics of the fluidized-bed.
- SO₂ removal efficiency of 90% was achieved at full load with a calcium-to-sulfur (Ca/S) molar ratio of 1.14 and temperature of 1,580 °F.
- SO₂ removal efficiency of 95% was achieved at full load with a Ca/S molar ratio of 1.5 and temperature of 1,580 °F.
- NO_x emissions were 0.15–0.33 lb/10⁶ Btu.
- CO emissions were less than 0.01 lb/10⁶ Btu.
- Particulate emissions were less than 0.02 lb/10⁶ Btu.

Operational

- Combustion efficiency ranged from an average 99.3% at low bed levels to an average 99.5% at moderate to full bed levels.

- Heat rate was 10,280 Btu/kWh (HHV, gross output) (33.2% efficiency) because the unit was small and no attempt was made to optimize heat recovery.
- An advanced particulate filter (APF), using a silicon carbide candle filter array, achieved 99.99% filtration efficiency on a mass basis.
- PFBC boiler demonstrated commercial readiness.
- ASEA Stal GT-35P gas turbine proved capable of operating commercially in a PFBC flue gas environment.

Economic

- The Tidd plant was a relatively small-scale facility, and as such, detailed economics were not prepared as part of this project.
- A recent cost estimate performed on Japan's 360-MWe PFBC Karita Plant projected a capital cost of \$1,263/kW (1997\$).

Project Summary

The Tidd PFBC technology is a bubbling fluidized-bed combustion process operating at 12 atmospheres (175 psi). Fluidized-bed combustion is inherently efficient because the pressurized environment enhances combustion efficiency, allows very low temperatures that mitigate thermal NO_x generation, promotes flue gas/sorbent reactions that increase sorbent utilization, and produces flue gas energy that is used to drive a gas turbine. The latter contributed significantly to system efficiency because of the high efficiency of gas turbines and the availability of gas turbine exhaust heat that can be applied to the steam cycle. A bed design temperature of 1,580 °F was established because it was the maximum allowable temperature at the gas turbine inlet and was well below temperatures for coal ash fusion, thermal NO_x formation, and alkali vaporization.

Coal crushed to one-quarter inch or less was injected into the combustor as a coal/water paste containing 25% water by weight. Crushed sorbent, either dolomite or limestone, was injected into the fluidized bed via two pneumatic feed lines, supplied from two lock hoppers. The sorbent feed system initially used two injector nozzles but was modified to add two more nozzles to enhance distribution.

In 1992, a 10-MWe equivalent APF was installed and commissioned as part of a research and development program and not part of the CCT Program demonstration. This system used ceramic candle filters to clean one-seventh of the exhaust gases from the PFBC system. The hot gas cleanup system unit replaced one of the seven secondary cyclones.

The Tidd PFBC demonstration plant accumulated 11,444 hours of coal-fired operations during its 54 months of operation. The unit completed 95 parametric tests, including continuous coal-fired runs of 28, 29, 30, 31, and 45 days. Ohio bituminous coals having sulfur contents of 2–4% were used in the demonstration.

Environmental Performance

Testing showed that 90% SO₂ capture was achievable with a Ca/S molar ratio of 1.14 and that 95% SO₂ capture was possible with a Ca/S molar ratio of 1.5, provided the size gradation of the sorbent being utilized was opti-

mized. This sulfur retention was achieved at a bed temperature of 1,580 °F and full bed height. Limestone induced deterioration of the fluidized-bed, and as a result, testing focused on dolomite. The testing showed that sulfur capture as well as sintering was sensitive to the fineness of the dolomite sorbent (Plum Run Greenfield dolomite was the design sorbent). Sintering of fluidized-bed materials, a fusing of the materials rather than effective reaction, had become a serious problem that required operation at bed temperatures below the optimum for effective boiler operation. Tests were conducted with sorbent size reduced from minus 6 mesh to a minus 12 mesh. The result with the finer material was a major positive impact on process performance without the expected excessive elutriation of sorbent. The finer material increased the fluidization activity as evidenced by a 10% improvement in heat transfer rate and an approximately 30% increase in sorbent utilization. In addition, the process was much more stable as indicated by reductions in temperature variations in both the bed and the evaporator tubes. Furthermore, sintering was effectively eliminated.

NO_x emissions ranged from 0.15–0.33 lb/10⁶ Btu, but were typically 0.2 lb/10⁶ Btu during the demonstration. These emissions were inherent in the process, which was operating at approximately 1,580 °F. No NO_x control enhancements, such as ammonia injection, were required. Emissions of carbon monoxide and particulates were less than 0.01 lb/10⁶ Btu and 0.02 lb/10⁶ Btu, respectively.

Operational Performance

Except for localized erosion of the in-bed tube bundle and the more general erosion of the water walls, the Tidd boiler performed extremely well and was considered a commercially viable design. The in-bed tube bundle experienced no widespread erosion that would require significant maintenance. While the tube bundle experienced little wear, a significant amount of erosion on each of the four water walls was observed. This erosion posed no problem, however, because the area affected is not critical to heat transfer and could be protected by refractory.

The prototype gas turbine experienced structural problems and was the leading cause of unit unavailability during the first three years of operation. However, design changes instituted over the course of the demonstration

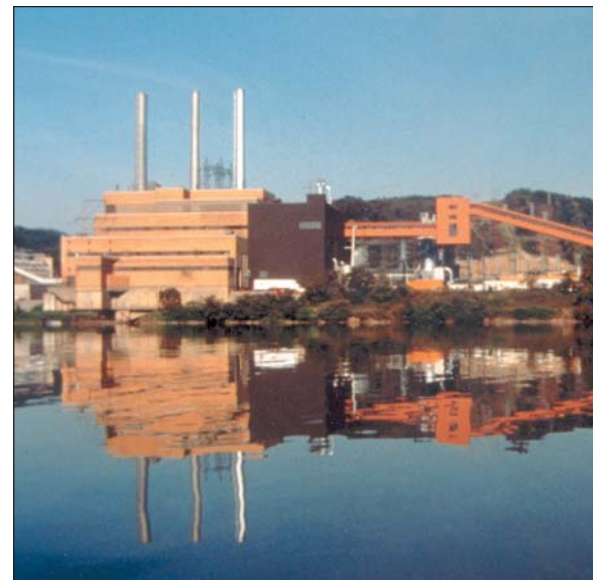

The PFBC demonstration at the repowered 70-MWe unit at Ohio Power's Tidd Plant led to significant refinements and understanding of the technology.

proved effective in addressing the problem. The Tidd demonstration showed that a gas turbine could operate in a PFBC flue gas environment.

Efficiency of the PFBC combustion process was calculated during testing from the amount of unburned carbon in cyclone and bed ash, together with measurements of the amount of carbon monoxide in the flue gas. Combustion efficiencies averaged 99.5% at moderate to full bed heights, surpassing the design efficiency of 99.0%.

Using data for typical full-load operation, a heat rate of 10,280 Btu/kWh (HHV) was calculated. This corresponds to a cycle thermodynamic efficiency of 33.2% at a point where the cycle produced 70 MWe of gross electrical power while burning Pittsburgh No. 8 coal. Because the Tidd plant was a repowering application at a comparatively small scale, the measured efficiency does not represent what would be expected for a larger utility-scale plant using Tidd technology. Studies conducted under the PFBC Utility Demonstration Project showed that efficiencies of over 40% are likely for a larger, utility-scale PFBC plant.

In summary, the Tidd project showed that the PFBC system could be applied to electric power generation. Further, the demonstration project led to significant refinements and understanding of the technology in the areas of turbine design, sorbent utilization, sintering, post-bed combustion, ash removal, and boiler materials.

Testing of the APF for over 5,800 hours of coal-fired operation showed that the APF vessel was structurally adequate; the clay-bonded silicon carbide candle filters were structurally adequate unless subjected to side loads from ash bridging or buildup in the vessel; bridging was precluded with larger particulates included in the particulate matter; and filtration efficiency (mass basis) was 99.99%.

Economic Performance

The Tidd plant was a relatively small-scale demonstration facility, so detailed economics were not prepared as part of this project. However, a recent cost estimate performed on Japan's 360-MWe PFBC Karita Plant projected a capital cost of \$1,263/kW (1997\$).

Commercial Applications

Combined-cycle PFBC permits use of a wide range of coals, including high-sulfur coals. The compactness of bubbling-bed PFBC equipment allows utilities to significantly increase capacity at existing sites. Compactness due to pressurized operation reduces space requirements per unit of energy generated. PFBC technology appears to be best suited for applications of 50 MWe or larger. Capable of being constructed modularly, PFBC generating plants permit utilities to add increments of capacity economically to match load growth. Plant life can be extended by repowering with PFBC using the existing plant area, coal- and waste-handling equipment, and steam turbine equipment.

The Tidd project received *Power* magazine's 1991 Powerplant Award. In 1992, the project received the National Energy Resource Organization award for demonstrating energy efficient technology.

Contacts

Michael J. Mudd, (614) 716-1585
American Electric Power
1 Riverside Plaza
Columbus, OH 43215
mjmudd@aep.com
(614) 716-1292 (fax)

Victor Der, DOE/HQ, (301) 903-2700
victor.der@hq.doe.gov

Donald W. Geiling, NETL, (304) 285-4784
donald.geiling@netl.doe.gov

References

Tidd PFBC Hot Gas Cleanup Program Final Report. Report No. DOE/MC/26042-5130. The Ohio Power Company. October 1995. (Available from NTIS as DE96000650.)

Tidd PFBC Demonstration Project Final Report, Including Fourth Year of Operation. The Ohio Power Company. August 1995. (Available from DOE Library/Morgantown, 1-800-432-8330, ext. 4184 as DE96000623.)

Tidd PFBC Demonstration Project Final Report, March 1, 1994–March 30, 1995. Report No. DOE/MC/24132-T8. The Ohio Power Company. August 1995. (Available from NTIS as DE96004973.)

Tidd PFBC Demonstration Project—First Three Years of Operation. Report No. DOE/MC/24132-5037-Vol. 1 and 2. The Ohio Power Company. April 1995. (Available from NTIS as DE96000559 for Vol. 1 and DE96003781 for Vol. 2.)

Tidd PFBC Demonstration Project—Project Performance Summary. U.S. Department of Energy. June 1999.



Coal and sorbent conveyors can be seen just after entering the Tidd plant.

Nucla CFB Demonstration Project

Project completed

Participant

Tri-State Generation and Transmission Association, Inc.

Additional Team Members

Foster Wheeler Energy Corporation*—technology supplier

Technical Advisory Group (potential users)—cofunder

Electric Power Research Institute (EPRI)—technical consultant

Location

Nucla, Montrose County, CO (Nucla Station)

Technology

Foster Wheeler's atmospheric circulating fluidized-bed (ACFB) combustion system

Plant Capacity/Production

110 MWe (gross), 100 MWe (net)

Coal

Western bituminous—

Salt Creek, 0.5% sulfur, 17% ash

Peabody, 0.7% sulfur, 18% ash

Dorchester, 1.5% sulfur, 23% ash

Project Funding

Total	\$160,049,949	100%
DOE	17,130,411	11
Participant	142,919,538	89

* Pyropower Corporation, the original technology developer and supplier, was acquired by Foster Wheeler Energy Corporation.

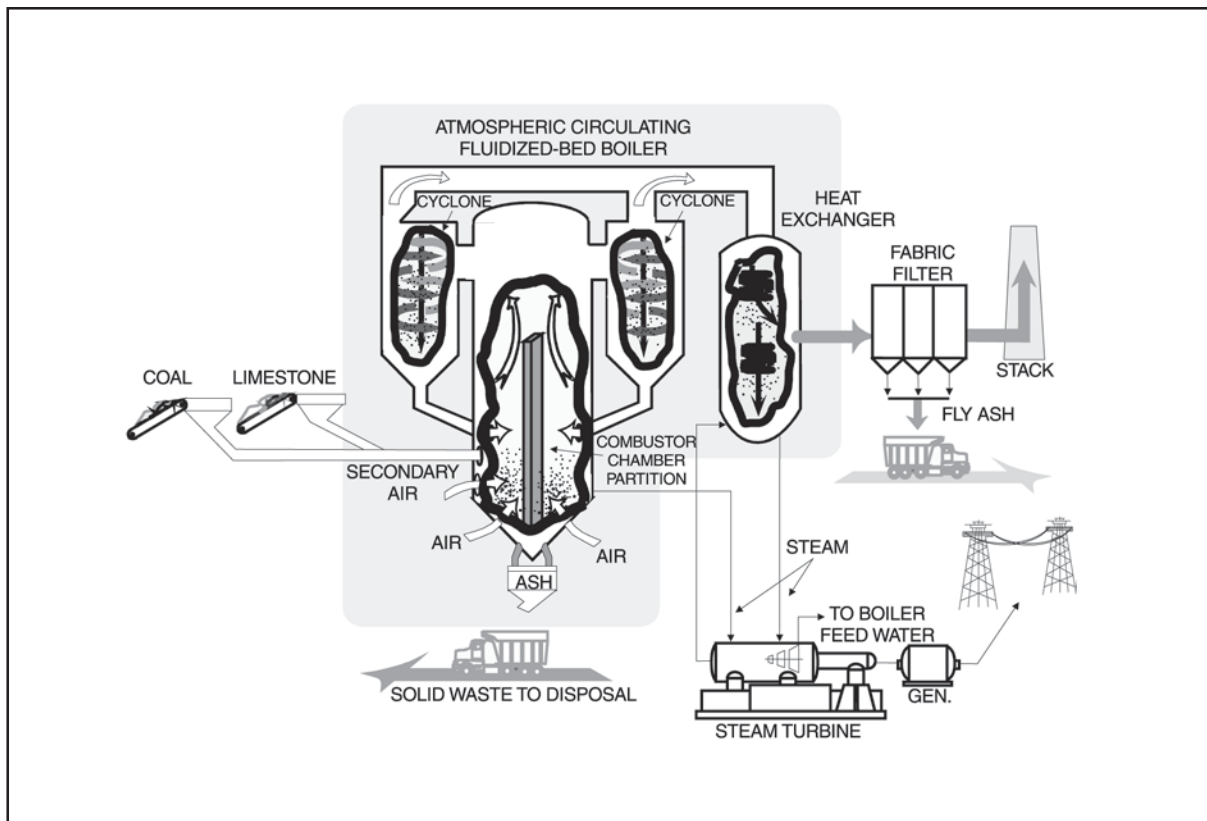

Project Objective

To demonstrate the feasibility of ACFB technology at utility scale and to evaluate the economic, environmental, and operational performance at that scale.

Technology/Project Description

Nucla's circulating fluidized-bed system operates at atmospheric pressure. In the combustion chamber, a stream of air fluidizes and entrains a bed of coal, coal ash, and sorbent (e.g., limestone). Relatively low combustion temperatures limit NO_x formation. Calcium in the sorbent combines with SO_2 gas to form calcium sulfite and sulfate solids, and solids exit the combustion chamber and flow into a hot cyclone. The cyclone separates the solids from the gases, and the solids are recycled for combustor temperature control. Continuous circulation of coal and sorbent improves mixing and

extends the contact time of solids and gases, thus promoting high utilization of the coal and high sulfur-capture efficiency. Heat in the flue gas exiting the hot cyclone is recovered in the economizer. Flue gas passes through a baghouse where particulate matter is removed. Steam generated in the ACFB is used to produce electric power.

Three small, coal-fired, stoker-type boilers at Nucla Station were replaced with a new 925,000 lb/hr ACFB steam generator capable of driving a new 74-MWe (gross) turbine generator. Extraction steam from this turbine generator powers three existing turbine generators (12.5 MWe gross each).

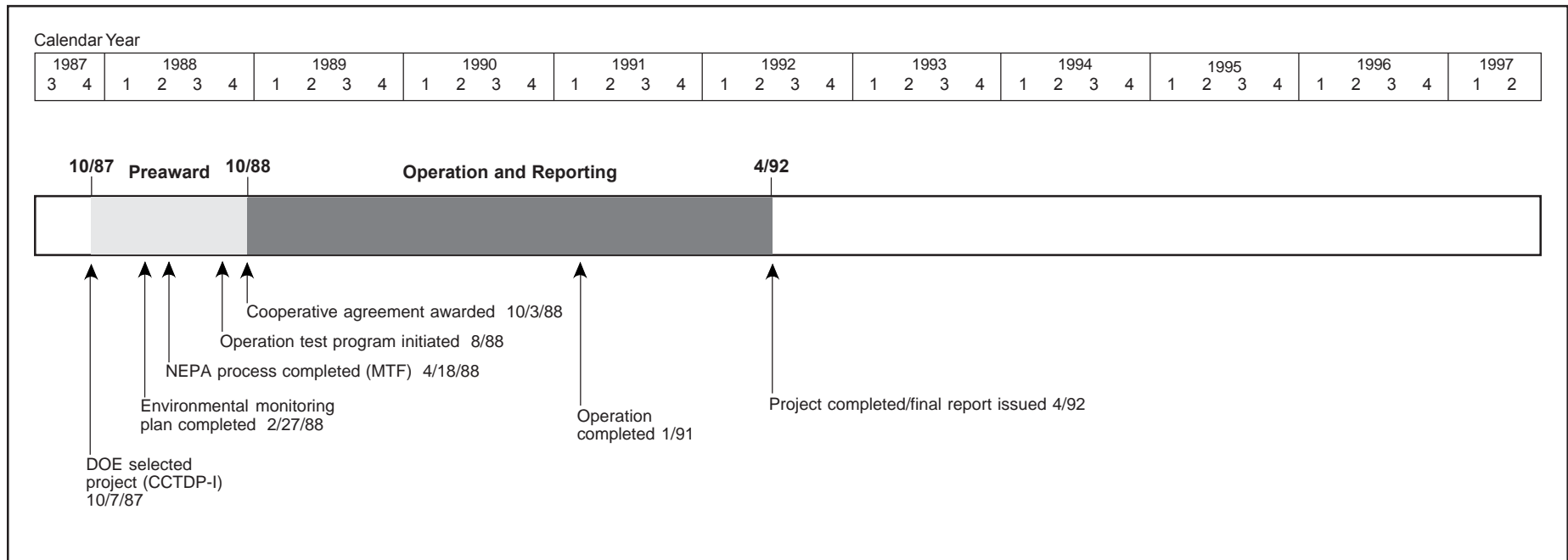

Results Summary

Environmental

- Bed temperature had the greatest effect on pollutant emissions and boiler efficiency.
- At bed temperatures below 1,620 °F, sulfur capture efficiencies of 70% and 95% were achieved at calcium-to-sulfur (Ca/S) molar ratios of 1.5 and 4.0, respectively.
- During all tests, NO_x emissions averaged 0.18 lb/10⁶ Btu and did not exceed 0.34 lb/10⁶ Btu.
- CO emissions ranged from 70–140 ppmv.
- Particulate emissions ranged from 0.0072–0.0125 lb/10⁶ Btu, corresponding to a removal efficiency of 99.9%.
- Solid waste was essentially benign and showed potential as an agricultural soil amendment, soil/roadbed stabilizer, or landfill cap.

Operational

- Boiler efficiency ranged from 85.6–88.6% and combustion efficiency ranged from 96.9–98.9%.

- A 3:1 boiler turndown capability was demonstrated.
- Heat rate at full load was 11,600 Btu/kWh and was 12,400 Btu/kWh at half load.

Economic

- Capital cost for the Nucla retrofit was \$1,123/kW and normalized power production cost was 64 mills/kWh.

Project Summary

Fluidized-bed combustion evolved from efforts to find a combustion process conducive to controlling pollutant emissions without external controls. Fluidized-bed combustion enables efficient combustion at temperatures of 1,400–1,700 °F, well below the thermal NO_x formation temperature (2,500 °F), and enables high SO_2 -capture efficiency through effective sorbent/flue gas contact. ACFB differs from the more traditional fluid-bed combustion. Rather than submerging a heat exchanger in the fluid bed, which dictates a low fluidization velocity, ACFB uses a relatively high fluidization velocity, which entrains the bed material. Hot cyclones capture and return the solids emerging from the turbulent bed to control temperature, extend the gas/solid contact time, and protect a downstream heat exchanger.

Interest and participation of DOE, EPRI, and the Technical Advisory Group (potential users) resulted in the evaluation of ACFB potential for broad utility application through a comprehensive test program. Over a two-and-a-half-year period, 72 steady-state performance tests were conducted and 15,700 hours logged. The result was a database that remains the most comprehensive available resource on ACFB technology.

Operational Performance

Between July 1988 and January 1991, the plant operated with an average availability of 58% and an average capacity factor of 40%. However, toward the end of the demonstration, most of the technical problems had been overcome. During the last three months of the demonstration, average availability was 97% and the capacity factor was 66.5%.

Over the range of operating temperature at which testing was performed, bed temperature was found to be the most influential operating parameter. With the exception of coal-fired configuration and excess air at elevated temperatures, bed temperature was the only parameter that had a measurable impact on emissions and efficiency.

Combustion efficiency, a measure of the quantity of carbon that is fully oxidized to CO_2 , ranged from 96.9–98.9%. Of the four exit sources of incompletely burned

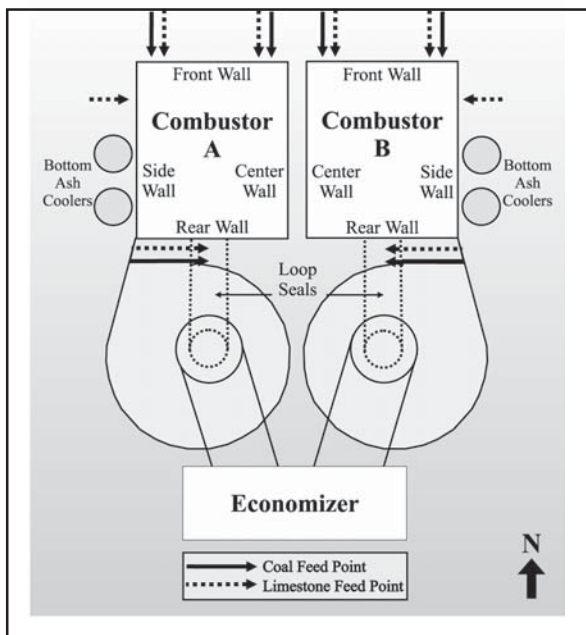

Plant layout with coal and limestone feed locations.

carbon, the largest was carbon contained in the fly ash (93%). The next largest (5%) was carbon contained in the bottom ash stream, and the remaining feed-carbon loss (2%) was incompletely oxidized CO in the flue gas. The fourth possible source, hydrocarbons in the flue gas, was measured and found to be negligible.

Boiler efficiencies for 68 performance tests varied from 85.6–88.6%. The contributions to boiler heat loss were identified as unburned carbon, sensible heat in dry flue gas, fuel and sorbent moisture, latent heat in burning hydrogen, sorbent calcination, radiation and convection, and bottom-ash cooling water. Net plant heat rate decreased with increasing boiler load, from 12,400 Btu/kWh at 50% of full load to 11,600 Btu/kWh at full load. The lowest value achieved during a full-load steady-state test was 10,980 Btu/kWh. These values were affected by the absence of reheat, the presence of the three older 12.5-MWe turbines in the overall steam cycle, the number of unit restarts, and part-load testing.

Exhibit 3-43 Effect of Bed Temperature on Ca/S Requirement

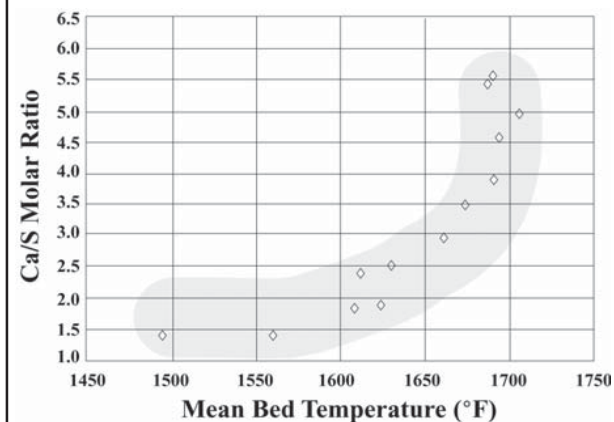

Environmental Performance

As indicated above, bed temperature had the greatest impact on ACFB performance, including pollutant emissions. Exhibit 3-43 shows the effect of bed temperatures on the Ca/S molar ratio requirement for 70% sulfur retention. The Ca/S molar ratios were calculated based on the calcium content of the sorbent only, and do not account for the calcium content of the coal. While a Ca/S molar ratio of about 1.5 was sufficient to achieve 70% sulfur retention in the 1,500–1,620 °F range, the Ca/S molar ratio requirement jumped to 5.0 or more at 1,700 °F or greater.

Exhibit 3-44 shows the effect of Ca/S molar ratio on sulfur retention at average bed temperatures below 1,620 °F. Salt Creek and Peabody coals contain 0.5% and 0.7% sulfur, respectively. To achieve 70% SO_2 reduction, or the 0.4 lb/10⁶ Btu emission rate required by the licensing agreement, a Ca/S molar ratio of approximately 1.5 is required. To achieve an SO_2 reduction of 95%, a Ca/S molar ratio of approximately 4.0 is necessary. Dorchester coal, averaging

Exhibit 3-44

Calcium Requirements and Sulfur Retentions for Various Fuels

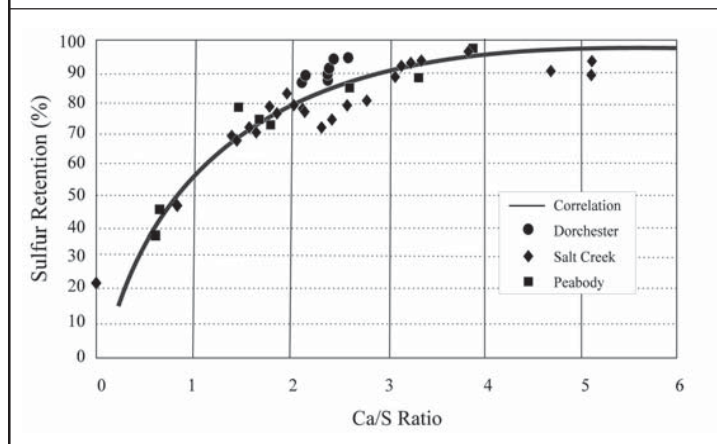

1.5% sulfur content, required a somewhat lower Ca/S molar ratio for a given reduction.

The NO_x emissions measured throughout the demonstration were less than 0.34 lb/10⁶ Btu, which is well below the regulated value of 0.5 lb/10⁶ Btu. The average level of NO_x emissions for all tests was 0.18 lb/10⁶ Btu. The NO_x emissions indicate a relatively strong correlation with temperature, increasing from 40 ppmv (0.06 lb/10⁶ Btu) at 1,425 °F to 240 ppmv (0.34 lb/10⁶ Btu) at 1,700 °F. Limestone feed rate was also identified as a variable affecting NO_x emissions, *i.e.*, somewhat higher NO_x emissions resulted from increasing calcium-to-nitrogen (Ca/N) molar ratios. The mechanism was believed to be oxidation of volatile nitrogen in the form of ammonia (NH₃) catalyzed by calcium oxide. The CO emissions decreased as temperature increased, from 140 ppmv at 1,425 °F to 70 ppmv at 1,700 °F.

At full load, the hot cyclones removed 99.8% of the particulates. With the addition of baghouses, removal efficiencies achieved on Peabody and Salt Creek coals were 99.905% and 99.959%, respectively. This equated to emission levels of 0.0125 lb/10⁶ Btu for Peabody coal and

0.0072 lb/10⁶ Btu for Salt Creek coal, well below the required 0.03 lb/10⁶ Btu.

Economic Performance

The final capital costs associated with the engineering, construction, and start-up of the Nucla ACFB system were \$112.3 million. This represents a cost of \$1,123/kW (net). The total power cost associated with plant operations between September 1988 and January 1991 was approximately \$54.7 million, resulting in a normalized cost of power production of 64 mills/kWh. The average monthly operating cost over this period was about \$1,888,000. Fixed costs represent about 62% of the total and include interest (47%), taxes (4.8%), depreciation (6.9%), and insurance (2.7%). Variable costs represent more than 38% of the power production costs and include fuel expenses (26.2%), non-fuel expenses (6.8%), and maintenance expenses (5.5%).

Commercial Applications

The Nucla project represented the first repowering of a U.S. utility plant with ACFB technology and showed the technology's ability to burn a wide variety of coals cleanly and efficiently. The comprehensive database resulting from the Nucla project enabled the resultant technology to be replicated in numerous commercial plants throughout the world. Nucla continues in commercial service.

Today, every major boiler manufacturer offers an ACFB system in its product line. There are now more than 170 fluidized-bed combustion boilers of varying capacity operating in the U.S. and the technology has made significant market penetration abroad. The fuel flexibility and ease of operation make it a particularly attractive power generation option for the burgeoning power market in developing countries.

Contacts

Joe Egloff, (303) 452-6111
Tri-State Generation and Transmission Association, Inc.
P.O. Box 33695
Denver, CO 80233
(303) 254-6066 (fax)

Victor K. Der, DOE/HQ, (301) 903-2700
victor.der@hq.doe.gov

Thomas Sarkus, NETL, (412) 386-5981
sarkus@netl.doe.gov

References

Demonstration Program Performance Test: Summary Reports. Report No. DOE/MC/25137-3104. Colorado-Ute Electric Association, Inc. March 1992. (Available from NTIS as DE92001299.)

Economic Evaluation Report: Topical Report. Report No. DOE/MC/25137-3127. Colorado-Ute Electric Association, Inc., March 1992. (Available from NTIS as DE93000212.)

Colorado-Ute Nucla Station Circulating Fluidized-Bed (CFB) Demonstration—Volume 2: Test Program Results. EPRI Report No. GS-7483. October 1991.

Nucla CFB Demonstration Project: Detailed Public Design Report. Report No. DOE/MC/25137-2999. Colorado-Ute Electric Association, Inc., December 1990. (Available from NTIS as DE91002081.)

Advanced Electric Power Generation Integrated Gasification Combined-Cycle

Piñon Pine IGCC Power Project

Project completed

Participant

Sierra Pacific Power Company

Additional Team Members

Foster Wheeler USA Corporation—architect, engineer, and constructor

The M.W. Kellogg Company—technology supplier

Bechtel Corporation—start-up engineer

Westinghouse Corporation—technology supplier

General Electric—technology supplier

Location

Reno, Storey County, NV (Sierra Pacific Power Company's Tracy Station)

Technology

Integrated gasification combined-cycle (IGCC) using the KRW air-blown pressurized fluidized-bed coal gasification system

Plant Capacity/Production

107 MWe (gross), 99 MWe (net)

Coal

Southern Utah bituminous, 0.5–0.9% sulfur (design coal); Eastern bituminous, 2–3% sulfur (planned test)

Project Funding

Total	\$335,913,000	100%
DOE	167,956,500	50
Participant	167,956,500	50

Project Objective

To demonstrate air-blown pressurized fluidized-bed IGCC technology incorporating hot gas cleanup (HGCU); to evaluate a low-Btu gas combustion turbine; and to assess

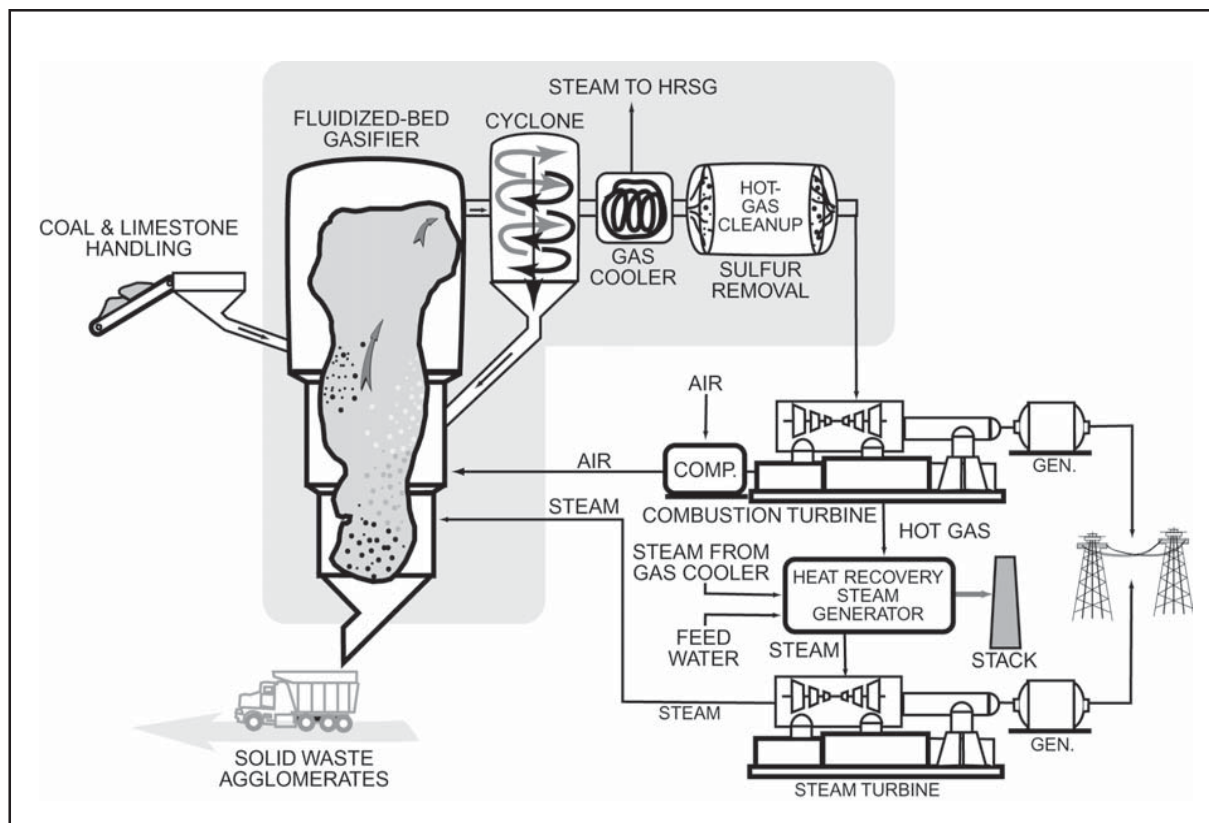

long-term reliability, availability, maintainability, and environmental performance at a scale sufficient to determine commercial potential.

Technology/Project Description

Dried and crushed coal and limestone are introduced into a KRW air-blown pressurized fluidized-bed gasifier. Crushed limestone is used to capture a portion of the sulfur. The sulfur reacts with the limestone to form calcium sulfide which, after oxidation, exits as calcium sulfate along with the coal ash in the form of agglomerated particles suitable for landfill.

Low-Btu coal gas (140 Btu/standard cubic foot) leaving the gasifier passes through cyclones, which return most of the entrained particulate matter to the gasifier. The gas, which leaves the gasifier at about 1,700 °F, is cooled to about 1,100 °F before entering the hot gas cleanup sys-

tem. During cleanup, virtually all of the remaining particulates are removed by ceramic candle filters, and final traces of sulfur are removed by reaction with a metal oxide sorbent in a transport reactor.

The cleaned gas then enters the GE MS6001FA (Frame 6FA) combustion turbine, which is coupled to a 61-MWe (gross) generator. Exhaust gas from the combustion turbine is used to produce steam in a heat recovery steam generator (HRSG). Superheated high-pressure steam drives a condensing steam turbine-generator designed to produce about 46 MWe (gross).

The IGCC plant is designed to remove more than 95% of the sulfur in the coal and emits 70% less NO_x and 20% less CO₂ than a comparable conventional coal-fired plant. The superior environmental performance is founded in the inherent efficiency of the pressurized fluidized-bed gasifier and incorporation of hot gas cleanup.

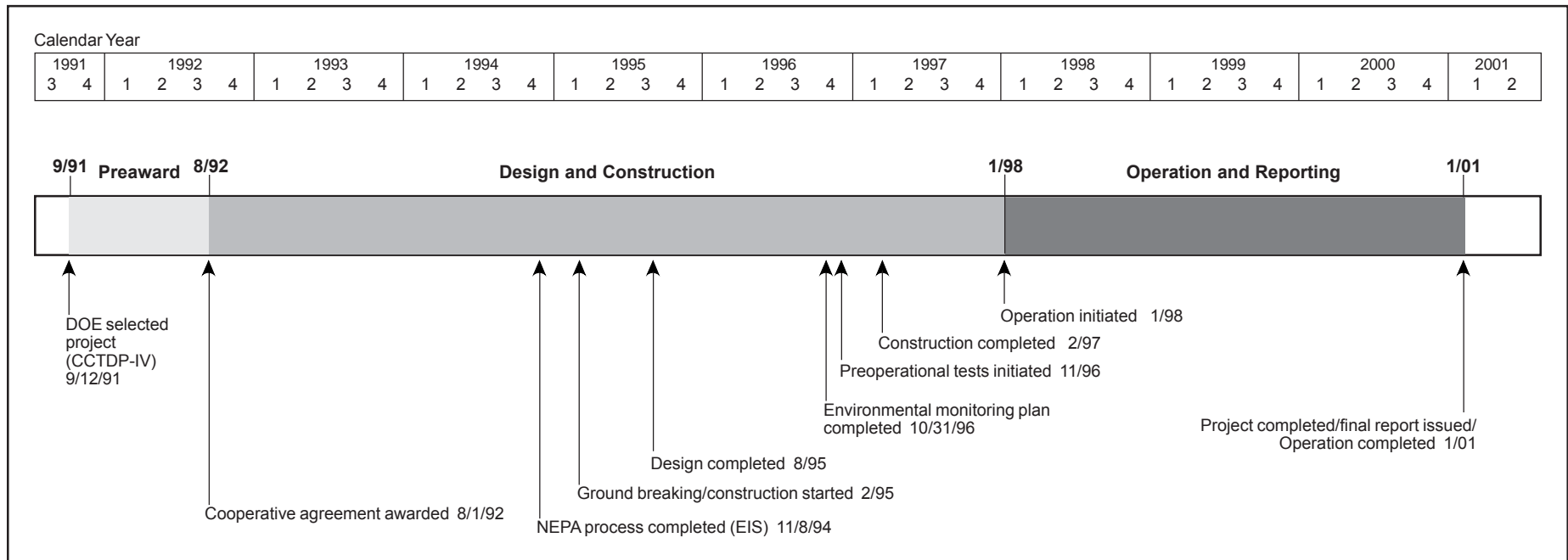

Results Summary

Operational

- The project succeeded in identifying and working through a number of problems, made possible only through full-scale system demonstrations, and positioned the technology for commercialization.
- Operational testing proved the ability of the KRW gasifier to produce coal-derived synthesis gas of design quality—two runs achieved 145 Btu/standard cubic foot.
- The power island demonstrated a 94% availability in a base load operating mode after working through a quality control problem in the HRSG, replacing an undersized turbine/generator coupling, and uncovering a shortcoming in the 2nd stage bucket shroud design in the hot gas path of the first-of-a-kind GE MS6001FA gas turbine.
- New start-up procedures for the IGCC system were developed to avoid accelerated temperature ramps upon ignition, which threatened the integrity of the refractory and ceramic candle filters, and to avoid use of an oxidant (air), which introduced the potential for

fire. But, once up to temperature and operating, the gasifier proved to be easy to control.

- The fines removal system for the hot gas particulate filtration vessel was modified, which included increasing the size of the filter fines depressurization bin filters, using nuclear- and vibration-based level detectors in all the bins, and incorporating Skimmer valves (which provide bursts of high-pressure gas) to prevent bridging of fines in bin outlet sections.
- Testing suggested modifying the hot gas particulate filter to improve durability and enhance protection for the gas turbine in the event of candle element failures.
- The lower section of the gasifier was enlarged to facilitate limestone and ash (LASH) removal and cooling.
- The hot gas desulfurizer and regenerator system, using a transport reactor, showed promise after replacing the sorbent with a more physically durable material.

Environmental

- Steady-state operation was not reached in the course of testing, so environmental performance could not be evaluated.

Economic

- Steady-state operation was not reached in the course of testing, so economic performance could not be evaluated.

Project Summary

The project set out to assess pressurized fluidized-bed gasification technology, hot gas (1,000 °F) sulfur and particulate removal, and low-Btu gas combustion turbine performance in an IGCC application. The testing provided valuable information to guide developers in completing a course of action toward design of a commercial IGCC configuration embodying the basic system technologies. But the IGCC system did not reach steady-state operation, so environmental and economic performance could not be evaluated. Following is a synopsis of the results coming out of the operational assessment completed during the demonstration period.

Operational Performance

The power island, which includes the gas turbine, heat recovery steam generator (HRSG), and steam turbine began operation on natural gas in October 1996. The gas turbine is a General Electric MS6001FA—a first-of-a-kind unit designed to operate at a 2,350 °F firing temperature on 140 Btu/standard cubic foot coal-derived synthetic gas (syngas). Overall, the power island performance was good, demonstrating a 94% availability in a base load operating mode. Early operations uncovered some quality control problems in the HRSG and an undersized gas turbine/generator coupling, which were easily resolved. Also identified was a shortcoming in the 2nd stage bucket shroud design, which caused a premature failure. The shroud on the periphery of the 2nd stage bucket in the hot gas path distorted radially and contacted and damaged the honeycomb seal blocks. General Electric replaced the bucket assembly and returned the damaged parts for root cause analysis.

Testing of the gasifier island included 18 separate start-up attempts, each ending with a malfunction and incorporation of modifications to improve system performance. The longest syngas production run was 25 hours and the cumulative hours totaled 127.5. Although brief, the operation proved the ability of the KRW gasifier to produce coal-derived syngas of the quality predicted by design—two runs achieved 145 Btu/standard cubic foot. The unit experienced accelerated temperature ramps during start-up (once the bed is ignited), which induced spalling of the gasifier refractory and threatened the integrity of the ce-

ramic candle filters in the hot gas particulate filtration system. Moreover, start-up used hot air, an oxidant, which has the potential to cause fires in a system normally operated in a reducing environment—residual fuel on or in components can catch fire if ignition temperatures are reached. A fire occurred during the last start-up and caused extensive damage to the hot gas particulate filtration system. At the close of the demonstration period, new inert gas start-up schemes were developed to address both rapid heat up and oxidation problems. Once up to temperature and operating, the gasifier proved easy to control.

Failure to remove fines from the hot gas particulate filtration (HGPF) vessel caused the bulk of failed start-ups. The system includes the HGPF, a screw feeder/cooler at the base of the HGPF, a filter fines collection bin (collection bin) to receive the HGPF fines, a filter fines depressurization bin (depressurization bin) to bring the system down to atmospheric pressure, and a filter fines feed bin (feed bin) to serve as a surge bin for the fines combustor. Testing led to development of several modifications to resolve the fines removal problems. Depressurization bin filters, through which vented gas passes to prevent emissions, were increased by an order of magnitude. Capacitance-type bin level detectors, including those in the HGPF, were replaced with nuclear level detection devices and vibration-based level detection, which subsequently functioned well. The HGPF vessel was further modified by incorporating a thermocouple array. Incorporation of Skimmer valves, providing a burst of high-pressure gas against the bin wall, in lieu of Evaser fluidizing nozzles, resolved the problem of fines bridging in the cone sections of the collection and depressurization bins.

Also, testing suggested modifying the hot gas particulate filter to improve durability and enhance protection for the gas turbine in the event of candle element failures. The ceramic candles are subject to failure from back-up of material in the fines removal system and thermal shock

and fatigue failures. And, the safeguard devices (SGD), installed with each candle filter to plug upon candle failure, did not perform effectively. Moreover, candle breakage requires system shutdown because the broken pieces plug the fines removal system. Testing led to design of an alternative candle filter system that enhances durability and to SGD designs that show promise for major improvements.

Repeated start-ups, accelerated temperature ramps during start-up in early testing, and a two-layer refractory design resulted in spalling of the old refractory, which in turn plugged the LASH removal annulus. Moreover, the internal volume of the annulus proved to be too small to allow sufficient cooling of the LASH. Resolution included replacing the original two-layer refractory with new, single-layer refractory and fire brick in selected locations and increasing the annulus volume. The single castable layer of refractory, using a revised anchoring pattern, was installed from the grid area of the annulus up to 18 feet into the fluidized-bed region to provide the needed resistance to fatigue failure.



HRSG in foreground and gasifier island in background.

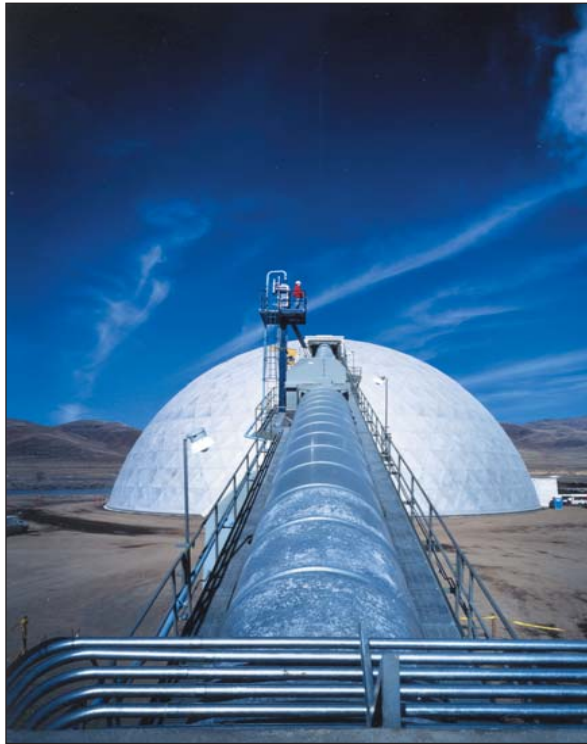

Conveyor leading to coal storage facility.

Failure of the fines removal system to provide a continuous output caused erratic operation of the fines combustor due to surging feed rates. The resultant surging of the combustor also contributed to seal damage between the combustor and HRSG. The solution was the addition of a diverter line from the fines removal system to the waste silo to provide an option prior to establishing a steady-state feed rate. An early candle filter failure pointed out poor SGD performance and inadequate protection for the recycle gas compressor, which experienced erosion of the impeller as a result of particulate incursion. The only other major failure was in the combustion air line, which burned through as a result of fuel accumulating in the line following system shutdown and bed slump. The solution was simply to blow out the line prior to start-up.

The hot gas desulfurizer and regeneration system showed promise. After the initial sorbent did not hold up physi-

cally in the entrained bed transport reactor system, another sorbent was identified and installed, and it performed well during the short runs.

The demonstration ended with Sierra Pacific trying to divest its power generation facilities, a condition of its earlier merger with Nevada Power. Wisconsin Public Service had expressed intentions to pursue commercialization of the Piñon Pine IGCC system and planned to purchase Sierra's Tracy Station, including the Piñon Pine Plant; however, the sale was cancelled by the Nevada legislature's imposition of a moratorium on sale of generation assets until July 2003. This reflects recognition that despite the difficulties encountered, the IGCC system shows promise. The demonstration resulted in the engineering knowledge requisite to establishing a commercial design for fluidized-bed gasification. The demonstration also provided valuable lessons learned for a broad range of advanced power generation technologies.

Commercial Applications

The Piñon Pine IGCC system concept is suitable for new power generation, repowering needs, and cogeneration applications. The net heat rate for a proposed greenfield plant using this technology is projected to be 7,800 Btu/kWh (43.7% efficiency), representing a 20% increase in thermal efficiency compared with a conventional pulverized coal plant with a scrubber and a comparable reduction in CO₂ emissions. The compactness of an IGCC system reduces space requirements per unit of energy generated relative to other coal-based power generation systems. The advantages provided by phased modular construction reduce the financial risk associated with new capacity additions. Furthermore, hot gas cleanup provides for extremely low emissions and efficiency gains through reduced heat loss.

The KRW IGCC technology offers tremendous fuel flexibility. It is capable of gasifying all types of coals, including high-sulfur, high-ash, low-rank, and high-swelling coals, as well as biowaste or refuse-derived waste, with minimal environmental impact. There are no significant process waste streams that require remediation. The only solid waste from the plant is a mixture of ash and calcium sulfate, a nonhazardous waste.

Contacts

Bob Werner, Vice President, Generation (702) 334-5860
Sierra Pacific Power Company
P.O. Box 10100
Reno, NV 89520-0024
bwerner@npc.com

Victor K. Der, DOE/HQ, (301) 903-2700
victor.der@hq.doe.gov

Donald W. Geiling, NETL, (304) 285-4784
donald.geiling@netl.doe.gov

References

Piñon Pine IGCC Power Project: A DOE Assessment. U.S. Department of Energy. December 2002.

Sierra Pacific Resources: Final Technical Report to the Department of Energy. Final Report. Sierra Pacific Power Company. January 2001.

Tracy Power Station – Unit No. 4, Piñon Pine Power Project Public Design Report. Sierra Pacific Power Company. December 1994.

Comprehensive Report to Congress on the Clean Coal Technology Programs: Piñon Pine IGCC Power Project. U.S. Department of Energy. June 1992.

Tampa Electric Integrated Gasification Combined-Cycle Project

Project Completed

Participant

Tampa Electric Company

Additional Team Members

Texaco Development Corporation—gasification technology supplier

General Electric Corporation—combined-cycle technology supplier

Air Products and Chemicals, Inc.—air separation unit supplier

Monsanto Enviro-Chem Systems, Inc.—sulfuric acid plant supplier

TECO Power Services Corporation—project manager and marketer

Bechtel Power Corporation—architect and engineer

Location

Mulberry, Polk County, FL (Tampa Electric Company's Polk Power Station (PPS), Unit No. 1)

Technology

Advanced integrated gasification combined-cycle (IGCC) system using Texaco's pressurized, entrained-flow, oxygen-blown gasifier technology

Plant Capacity/Production

315 MWe (gross), 250 MWe (net)

Coal

Illinois #5 & #6, Pittsburgh #8, West Kentucky #11, and Kentucky #9, Indiana #5 & #6 (2.5–3.5% sulfur); petcoke; petcoke/coal blends; and biomass

*Additional project cost overruns were funded 100% by the participant for a final total project funding of \$606,916,000.

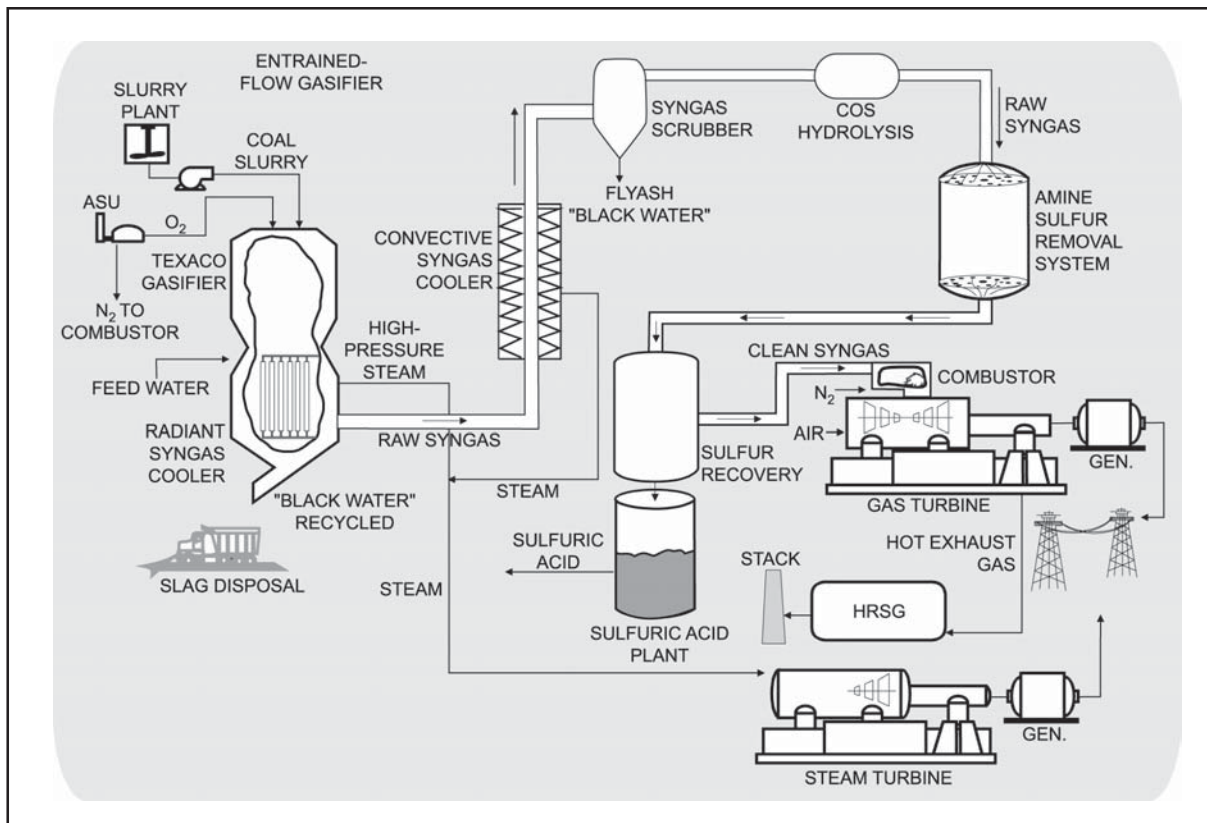

Project Funding

Total*	\$303,288,446	100%
DOE	150,894,223	49
Participant	152,394,223	51

Project Objective

To demonstrate IGCC technology in a greenfield commercial electric utility application at the 250-MWe size using a pressurized, entrained-flow, oxygen-blown gasifier with full heat recovery, conventional cold-gas cleanup, and an advanced gas turbine with nitrogen injection for power augmentation and NO_x control.

Technology/Project Description

Coal/water slurry and oxygen are reacted at high temperature and pressure to produce approximately 245 Btu/SCF syngas (LHV) in a Texaco gasifier. Molten ash flows out of the bottom of the gasifier into a water-filled sump where it forms a solid slag. The syngas moves from the gasifier to a

radiant syngas cooler and a convective syngas cooler (CSC), which cool the syngas while generating high-pressure steam. The cooled gases flow to a water-wash syngas scrubber for particulate removal. Next, a hydrolysis reactor converts carbonyl sulfide (COS) in the raw syngas to hydrogen sulfide (H₂S) that is more easily removed. The raw syngas is then further cooled before entering a conventional amine sulfur removal system and sulfuric acid plant (SAP). The cleaned gases are then reheated and routed to a combined-cycle system for power generation. A GE MS 7001FA gas turbine generates 192 MWe. Thermal NO_x is controlled to 0.7 lb/MWh by injecting nitrogen. A steam turbine uses steam produced by cooling the syngas and superheated with the gas turbine exhaust gases in the HRSG to produce an additional 123 MWe. The air separation unit consumes 55 MW and auxiliaries require 10 MW, resulting in 250 MWe net power to the grid. The plant heat rate is 9,650 Btu/kWh (HHV).

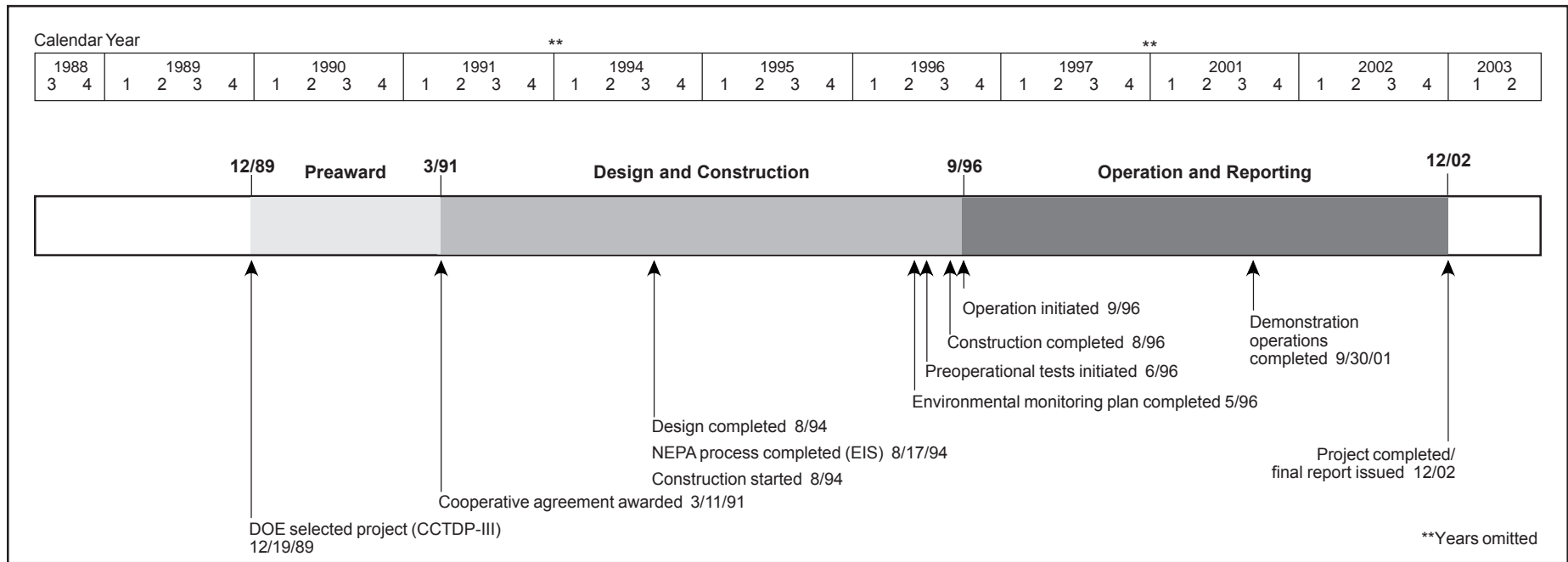

Results Summary

Environmental Performance

- The PPS IGCC removed over 97% of feedstock sulfur when operated on low-cost, high-sulfur coal, petcoke, and coal/petcoke blends.
- Typical NO_x emissions were 0.7 lb/MWh, which were below the permitted limit of 0.9 lb/MWh and far below New Source Performance Standard (NSPS) NO_x levels of 1.6 lb/MWh for electric utility units.
- The PM emissions were typically less than 0.04 lb/MWh, which is about 5% of those from conventional coal-fired plants equipped with electrostatic precipitation.
- The CO emissions were permitted at 99 lb/hr and averaged 7.2 lb/hr; volatile organic compound (VOC) emissions were negligible; and mercury emissions (on coal) without controls were half the potential release based on mercury levels in the coal.

Operational Performance

- The PPS combustion turbine logged 34,800 hours over the 5-year demonstration, of which 28,500 hours were syngas-fired; syngas firing produced over 8.6 million MWh of electricity.
- The gasifier on-stream factor steadily increased, reaching 70–80% after 2½ years; overall PPS availability, with distillate fuel as backup, averaged 90% after 1½ years.
- Carbon conversion was lower than expected—in the low to mid 90% range versus the expected 97.5–98%. This rendered the ASU design capacity inadequate because of a need to recycle flyash, lowering PPS output to 235 MWe net, and required doubling the capacity of the solids handling system.
- Refractory liner life was problematic during the demonstration largely due to frequent fuel changes and attendant undesirable fluctuations in operating conditions, but a coal/petcoke blend was identified to eliminate the problem in commercial service.
- In the high-temperature heat recovery systems downstream of the gasifier, the radiant syngas cooler seals

underwent design changes or corrections for fabrication defects; convective syngas coolers required geometric improvements to reduce plugging; and raw gas/clean gas heat exchangers required removal due to stress corrosion.

- A COS hydrolysis unit had to be added to meet sulfur-reduction targets and an ion exchange unit added to prevent buildup of heat-stable salts in the MDEA unit.
- “Y” strainers and a 10 micron filter system proved critical to turbine protection from pipe-scale during start-ups.

Economic Performance

- A capital cost of \$1,650/kW (2001\$) was estimated for a new 250 MWe (net) IGCC plant based on the PPS configuration incorporating lessons learned. A capital cost of \$1,300/kW (2001\$) was estimated for a new plant that allowed for benefits derived from economies of scale, technology improvements, and replication of proven configurations to eliminate costly reinvention.

Project Summary

Tampa Electric worked with the local community, state organizations, and environmental groups to make the project an environmental showcase; and engaged DOE and the technical community to move IGCC closer to mainstream market acceptance. Both of these goals were met.

This project has been the recipient of numerous environmental and technological achievement awards. These include the Ecological Society of America Corporate Award, the Florida Audubon Society Corporate Award, and *Power* magazine's 1997 Power Plant of the Year Award. The plant was inducted into *Power* magazine's Power Plant Hall of Fame.

Over the 5-year demonstration period, Tampa Electric carried out a systematic campaign to address and resolve the usual technical issues accompanying first-of-a-kind plants. Tampa Electric showed through the demonstration that a modest-sized utility, with expertise in coal-fired generation, can build and operate an IGCC plant.

Environmental Performance

The PPS IGCC removed over 97% of the feedstock sulfur when operated on low-cost, high-sulfur coals, petcoke, and blends. A material balance on a 3.0% sulfur coal showed that 7.0% of the sulfur is locked up in the inert slag leaving the gasifier. The MDEA acid gas system removed 97.5% of the H₂S from the raw syngas. The COS hydrolysis to H₂S proved critical to maintaining high sulfur capture efficiency because 5% of the sulfur in coal feedstocks was converted to COS (twice the amount expected) and the MDEA system was not effective in removing COS. The SAP recovered 99.7% of the sulfur it was fed.

Permit limits on NO_x emissions during the PPS demonstration period were 25 parts per million by volume on a dry basis (ppmvd) corrected to 15% O₂. This value equated to 35 parts per million (ppm) as measured at the stack by a continuous emissions monitor (CEM). The permit limit is also equivalent to about 220 lb/hr NO_x or 0.9 lb/MWh. Typical Polk IGCC NO_x emissions were about 0.7 lb/MWh, or below 30 ppm by CEM. These emission rates are a fraction of those from conventional coal-fired power plants equipped with low-NO_x combustion systems. For comparison, the NSPS for electric utility units is 1.6 lb/MWh, regardless of fuel type.

The PM emissions from the IGCC are typically less than 0.04 lb/MWh, which is approximately 5% of those from conventional coal-fired plants equipped with electrostatic precipitators. These near-zero emissions are the result of the concentrated, low-volume raw syngas flow and application of intensive liquid scrubbing and no less than 15 stages of liquid-gas contact.

The CO emissions, permitted at 99 lb/hr, averaged 7.2 lb/hr. The VOC emissions, permitted at 3 lb/hr, averaged 0.02 lb/hr. Mercury emissions were not regulated, but measurements taken showed that the IGCC removed about half of the mercury constituent in coal feedstocks.

Operational Performance

Over the course of the demonstration, the PPS combustion turbine logged 34,800 hours of which 28,500 hours were syngas fired. The 28,500 hours of syngas firing produced over 8.6 million MWh of electricity. In producing the syngas, the gasifier typically consumed 2,500 tons of coal or coal/petcoke blends per day.

The gasifier and associated systems involved in producing clean syngas showed steady improvement in the unit's in-service (on-stream) factor over the first four years, reaching 70–80% after 2½ years, before suffering a setback in the fifth and final demonstration year. The fifth year was not considered representative. It included a lengthy planned outage to deal with gasifier refractory damage incurred by frequent feedstock changes, followed by a rare ASU forced outage and the one-time removal of sootblower lances. The on-stream factor is the percentage of time the gasifier and associated systems were in operation over the total number of hours in the year of operation. The availability of the combined-cycle power block to produce electricity from either syngas or distillate was approximately 90% over the last four years of the demonstration. Tampa Electric also calculated on-peak availability because of the importance of the plant in meeting peak summer demand. The peak availabilities for 2000 and 2001 were 94.9% and 97.7%, respectively.

The following is a summary of the highlights of the technical issues that emerged during the demonstration. Most of the issues were resolved, and others served as lessons learned to improve the technology for future plants. To-

gether, the issues served to advance the technology closer to widespread commercial deployment.

Lower-than-anticipated carbon conversion in the gasifier had major cost and performance impacts that reverberated through the IGCC system. Carbon conversions of 97.5–98% per pass were expected based on performance of smaller Texaco gasifiers. The PPS gasifier achieved per pass carbon conversion in the low- to mid- 90% range.

Even at design capacity, the ASU could not deliver enough air to meet the total gasifier oxygen requirements given the unexpectedly low carbon conversion and the resulting need to recycle flyash (which reduced fuel quality). Moreover, Tampa Electric desired the flexibility to process low-quality fuels.

Essentially all carbon steel parts in contact with the slurry feedstock had to be replaced or coated with corrosion-resistant materials, and high-wear areas had to be hardened.

Tampa Electric evaluated numerous modifications to the slurry feed injectors in an attempt to resolve the carbon conversion issue. Only marginal improvement resulted.

A two-year gasifier refractory liner life commercial goal established for the PPS was not met during the demonstration period primarily because of frequent fuel changes. The fuel changes introduced risk in operational settings and less-than-optimal operating conditions as adjustments were made. Also, the high number of start-up and shutdown cycles experienced during the demonstration period accelerated refractory spalling.

Tampa Electric carried out extensive feedstock testing during the demonstration with refractory life being a prime consideration. Testing showed that a blend of 45% Black Beauty and Mina Norte coals with 55% petroleum coke provided excellent cost and performance characteristics and the potential for long refractory liner life.

Contributing to the refractory degradation was the inability to directly measure gasifier temperatures on a realtime basis. Thermocouples failed to survive the gasifier flow path. Gasifier temperature measurements primarily relied on "inferential measurement" based on methane formation. Monitoring and control of gasifier temperature also is critical for control of slag viscosity and flyash volume.

All radiant syngas cooler seals eventually failed due to either fabrication defects or design flaws, all of which were corrected. Corrections included removal of all but 8 of the 122 sootblower lances. Only four lances are used as sootblowers. The other four serve as purge points for injection of N₂ during start-up and shutdown.

The CSC fire-tube heat exchanger was a source of frequent plugging and forced outages through 1999. The plugging primarily occurred at the CSC tubesheet inlet. In 1999, significant geometric improvements dramatically reduced plugging by more than half. Although not eliminated, CSC pluggage is deemed manageable.

The gasifier's lower-than-expected carbon conversion required twice as much fly ash and associated black water to be processed as originally designed. This increased volume essentially overwhelmed the solids handling system, precluded slag sales, and posed significant disposal costs. To resolve these issues, Tampa Electric (1) doubled the capacity of the fines (predominately flyash) handling system; (2) provided the capability to recycle 100% of the settler bottoms flyash to the gasifier slurry preparation system; (3) used condensate water instead of grey water in the slag removal system and stripped the ammonia from that condensate water; and (4) added a drag conveyor and screen to de-water and separate the fly-ash from the slag. With these changes, operation on 100% coal enabled sales of the slag while recycling 100% of the settler bottom flyash and generating 235 MWe (net). Tampa Electric future plans include increasing ASU capacity to provide enough oxygen to compensate for added fuel required to boost output to the rated capacity of 250 MWe year round.

In the original IGCC design, heat exchangers were incorporated downstream of the CSC to recover process heat by warming clean gas and diluent N₂ going to the combustion turbine. Flyash deposits from the raw syngas resulted in stress corrosion, cracking of the tubes, and turbine blade damage. These heat exchangers were removed because the heat recovery, less than 1.7% of the fuel's heating value, did not warrant the cost of redesign.

Tampa Electric incorporated a COS hydrolysis system in August 1999. An ion exchange system was subsequently

added to control a high rate of heat-stable salt formation resulting from COS hydrolysis.

The only major power block forced outages during syngas-based operation resulted from failures of the raw gas/clean gas heat exchanger (since removed) in the absence of protective "Y" strainers. The "Y" strainers had been removed for repair. "Y" strainers subsequently proved critical for start-ups because of the release of large volumes of pipe scale. To increase turbine protection and reduce "Y" strainer cleaning, a 10 micron final syngas filter was installed upstream of the syngas strainers. This filter was sized to catch a year's worth of pipe scale.

Economic Performance

Tampa Electric estimated a capital cost of \$1,650/kW (2001\$) for installing a new single-train 250-MWe unit at the Polk site, based on the PPS configuration and incorporating all lessons learned. This estimate reflected the cost of the plant as if it were instantaneously conceived, permitted, and erected (overnight cost) in mid-2001. The single-train PPS configuration contributed to the high cost in that no benefits accrued from economies of scale in using common balance-of-plant systems. Tampa Electric also noted a number of site-specific factors adding to high costs. Tampa Electric developed another capital cost estimate, that included moderated site-specific factors and allowed benefits from economies of scale, technical improvement, and replication of proven configurations to eliminate costly re-invention. Application of these benefits reduced the estimated capital cost to \$1,300/kW (2001\$).

Commercial Applications

During the course of the demonstration, Tampa Electric addressed the future of IGCC, reflecting on typical concerns expressed by visitors, numbering over 2,500 and representing 20 countries. In regard to cost, the primary concern, Tampa Electric pointed out that capital costs will be lower for next-generation IGCC, further IGCC demonstrations would accelerate cost reduction, and higher initial costs for IGCC can be offset by long-term fuel savings. As to the associated factor of economic risk, Tampa Electric observed that (1) assumption of overall plant performance risk by a single entity rather than separate entities for indi-

vidual process units would reduce the difficulty in obtaining financing; (2) a return to steady economic growth in the United States would encourage potential IGCC users to take a longer-term investment view, and (3) a lasting change in the expected availability or price differential of natural gas to coal would tip the risk-versus-reward scale toward IGCC. Also, environmental legislation requiring mercury or CO₂ removal would provide an economic advantage to IGCC over conventional coal-fired power generation because these emissions are readily removed from concentrated IGCC gas streams.

As to availability, Tampa Electric noted that: (1) the PPS gasifier availability is lower than can be expected for subsequent IGCC plants incorporating lessons learned; (2) overall PPS availability, including operation on backup fuel, is very high; and (3) the PPS experience showed that availability can be effectively managed.

Contacts

Mark Hornick, (863) 428-5988
General Manager, Polk Power Station
TECO Energy
P.O. Box 111
Tampa, FL 33601-0111
(863) 428-5927 (fax)

Victor K. Der, DOE/HQ, (301) 903-2700
victor.der@hq.doe.gov

Leo E. Makovsky, NETL, (412) 386-5814
leo.makovsky@netl.doe.gov

References

Tampa Electric Polk Power Station Integrated Gasification Combined-Cycle Project—Final Technical Report. Tampa Electric Company. August 2002.

Tampa Electric Integrated Gasification Combined-Cycle Project—An Update. U.S. Department of Energy. July 2000.

Wabash River Coal Gasification Repowering Project

Project completed

Participant

Wabash River Coal Gasification Repowering Project Joint Venture (a joint venture of Dynegy and PSI Energy, Inc.)

Additional Team Members

PSI Energy, Inc.—host

Dynegy (formerly Destec Energy, Inc., a subsidiary of Natural Gas Clearinghouse)—engineer and gas plant operator

Location

West Terre Haute, Vigo County, IN (PSI Energy's Wabash River Generating Station, Unit No. 1)

Technology

Integrated gasification combined-cycle (IGCC) using Global Energy's two-stage pressurized, oxygen-blown, entrained-flow gasification system—E-Gas Technology™

Plant Capacity/Production

296 MWe (gross), 262 MWe (net)

Coal

Illinois Basin bituminous (Petroleum coke also used)

Project Funding

Total	\$438,200,000	100%
DOE	219,100,000	50
Participant	219,100,000	50

Project Objective

To demonstrate utility repowering with a two-stage, pressurized, oxygen-blown, entrained-flow IGCC system, including advancements in the technology relevant to the use of high-sulfur bituminous coal; and to assess long-

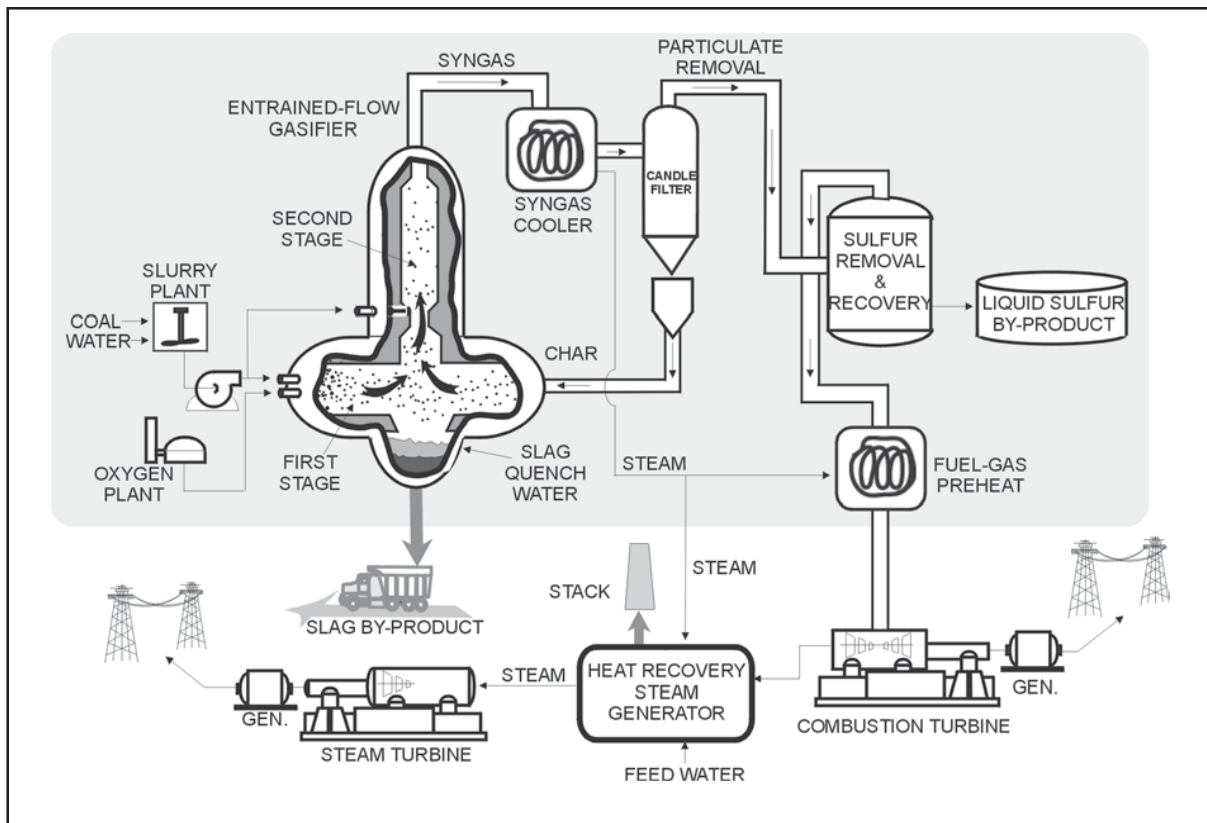

term reliability, availability, and maintainability of the system at a fully commercial scale.

Technology/Project Description

The Destec, now E-Gas Technology™, process features an oxygen-blown, continuous-slugging, two-stage, entrained flow gasifier. Coal is slurrified, combined with 95% pure oxygen, and injected into the first stage of the gasifier, which operates at 2,600 °F/400 psig. In the first stage, the coal slurry undergoes a partial oxidation reaction at temperatures high enough to bring the coal's ash above its melting point. The fluid ash falls through a tap hole at the bottom of the first stage into a water quench, forming an inert vitreous slag. The syngas flows to the second stage, where additional coal slurry is injected. This coal is pyrolyzed in an endothermic reaction with the hot syngas to enhance syngas heating value and improve efficiency.

The syngas then flows to the syngas cooler, essentially a fire tube steam generator, to produce high-pressure saturated steam. After cooling in the syngas cooler, particulates are removed in a hot/dry filter and recycled to the gasifier. The syngas is further cooled in a series of heat exchangers. The syngas is water-scrubbed to remove chlorides and passed through a catalyst that hydrolyzes carbonyl sulfide into hydrogen sulfide. Hydrogen sulfide is removed in the acid gas removal system using MDEA-based absorber/stripper columns. A Claus unit is used to produce elemental sulfur as a salable by-product. The "sweet" gas is then moisturized, preheated, and piped to the power block. The power block consists of a single 192-MWe General Electric MS 7001FA (Frame 7 FA) gas turbine, a Foster Wheeler single-drum heat recovery steam generator with reheat, and a 1952-vintage Westinghouse reheat steam turbine.

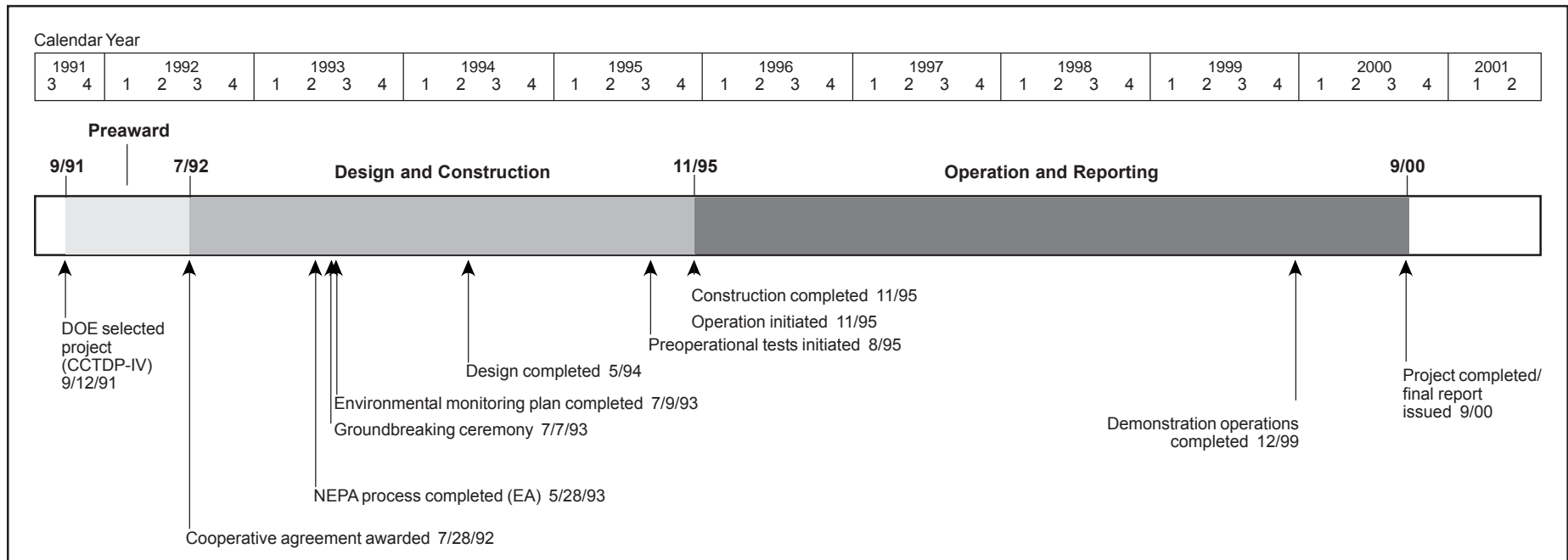

Results Summary

Environmental

- The SO₂ capture efficiency was greater than 99%, keeping SO₂ emissions consistently below 0.1 lb/10⁶ Btu and reaching as low as 0.03 lb/10⁶ Btu. Sulfur-based pollutants were transformed into 99.99% pure sulfur, a highly valued by-product—33,388 tons produced during the demonstration period.
- The NO_x emissions were 0.15 lb/10⁶ Btu, which meets the 2003 target emission limits for ozone non-attainment areas, or 1.09 lb/MWh, and exceeds performance requirement based on the New Source Performance Standard of 1.6 lb/MWh.
- Particulate emissions were below detectable limits.
- Carbon monoxide emissions, averaging 0.05 lb/10⁶ Btu, were well within industry standards.
- Coal ash was converted to a low-carbon vitreous slag, impervious to leaching and valued as an aggregate in construction or as grit for abrasives and roofing materials; and trace metals from petroleum coke were also encased in an inert vitreous slag.

Operational

- Over the course of the demonstration, the IGCC unit operated on coal for over 15,000 hrs, processed over 1.5 million tons of coal, and produced over 23 trillion Btu of syngas and 4 million MWh of electricity.
- Design changes in the first year included: (1) using a less tenacious refractory in the second-stage gasifier and changing the flow path geometry to eliminate ash deposition on the second-stage gasifier walls and downstream piping; (2) changing to improved metallic candle filters to prevent particulate breakthrough in the hot gas filter; and (3) installing a wet chloride scrubber and a COS catalyst less prone to poisoning to eliminate chloride and metals poisoning of the COS catalyst.
- The second year identified cracking in the gas turbine combustion liners and tube leaks in the heat recovery steam generator (HRSG). Resolution involved replacement of the gas turbine fuel nozzles and liners and modifications to the HRSG to allow for more tube expansion.
- The third year was essentially trouble free and the IGCC unit underwent fuel flexibility tests, which

showed that the unit operated trouble free, without modification, on a second coal feedstock, a blend of two different Illinois #6 coals, and petroleum coke. Overall thermal performance actually improved during petroleum coke operation, increasing plant efficiency from 39.7% to 40.2%.

- In the fourth year, the gas turbine incurred damage to the rotor and stator in rows 14 through 17 of the air compressor causing a 3-month outage. But over the four years of operation, availability of the gasification plant steadily improved reaching 79.1% in 1999.

Economic

- The overall cost of the IGCC plant was \$417 million, which equates to about \$1,590/kW in 1994 dollars. For an equivalent greenfield project the cost was estimated at \$1,700/kW. Capital cost estimates for a new 285 MWe (net) greenfield IGCC plant incorporating lessons learned, technology improvements, and a heat rate of 8,526 Btu/kWh are \$1,318/kW (2000\$) for a coal-fueled unit and \$1,260 (2000\$) for a petroleum coke-fueled unit.

Project Summary

The Wabash River Coal Gasification Repowering Project repowered a 1950s vintage pulverized coal-fired plant, transforming the plant from a nominally 33% efficient, 90-MWe unit into a nominally 40% efficient, 262-MWe (net) unit. Cinergy, PSI's parent company, dispatches power from the project, with a demonstrated heat rate of 8,910 Btu/kWh (HHV), second only to their hydroelectric facilities on the basis of environmental emissions and efficiency.

Beyond the integration of an advanced gasification system, a number of other advanced features contributed to the high energy efficiency. These included: (1) hot/dry particulate removal to enable gas cleanup without heat loss, (2) integration of the gasifier high-temperature heat recovery steam generator with the gas turbine-connected HRSG to ensure optimum steam conditions for the steam turbine, (3) use of a carbonyl sulfide (COS) hydrolysis process to enable high-percentage sulfur removal, (4) recycle of slag fines for additional carbon recovery, (5) use of 95% pure oxygen to lower power requirements for the oxygen plant, and (6) fuel gas moisturization to reduce steam injection requirements for NO_x control.

Over the four-year demonstration period starting in November 1995, the facility operated on coal for more than 15,000 hours and processed over 1.5 million tons of coal to produce more than 23 trillion Btu of syngas. For several of the months, syngas production exceeded one trillion Btu. By the end of the demonstration, the 262-MWe IGCC unit had captured and produced 33,388 tons of sulfur.

Operational Performance

The first year of operation resolved problems with: (1) ash deposition on the second stage gasifier walls and downstream piping, (2) particulate breakthrough in the hot gas filter system, and (3) chloride and metals poisoning of the COS catalyst. Modifications to the second-stage refractory to avoid tenacious bonds with the ash and to the hot gas path flow geometry corrected the ash deposition problem. Replacement of the ceramic candle filters with metallic candles proved to be largely successful. A follow-on metallic candle filter development effort ensued using a hot gas slipstream, which resulted in improved candle filter

metallurgy, blinding rates, and cleaning techniques. The combined effort all but eliminated downtime associated with the filter system by the close of 1998. Installation of a wet chloride scrubber eliminated the chloride problem by September 1996 and use of an alternate COS catalyst less prone to trace metal poisoning provided the final cure for the COS system by October 1997.

The second year of operation identified cracking problems with the gas turbine combustion liners and tube leaks in the HRSG. Replacement of the fuel nozzles and liners solved the cracking problem. Resolution of the HRSG problem required modification to the tube support and HRSG roof/penthouse floor to allow for more expansion.

By the third year, downtime was reduced to nuisance items such as instrumentation-induced trips in the oxygen plant and high-maintenance items such as replacement of high-pressure slurry burners every 40–50 days. In the third year, the IGCC unit underwent fuel flexibility tests. The unit operated effectively, without modification or incident, on a second coal feedstock, a blend of two different Illinois #6 coals, and petroleum coke (petcoke). These tests added to the fuel flexibility portfolio of the gasifier, which had previously processed both lignite and subbituminous coals during its earlier development. The overall thermal performance of the IGCC unit actually improved during petcoke operation. The unit processed over 18,000 tons of high-sulfur petcoke and produced

350 billion Btu of syngas. There was a negligible amount of tar production and no problems were encountered in removing the dry char particulate despite a higher dust loading. Exhibit 3-45 provides a summary of the thermal performance of the unit on both coal and petcoke.

The fourth year of operation was marred by a 3-month outage due to damage to the rotor and stator in rows 14 through 17 of the gas turbine air compressor. However, over the four years of operation, availability of the gasification plant steadily improved, reaching 79.1% in 1999. Exhibit 3-46 provides a summary of the production statistics during the demonstration period.

Environmental Performance

The IGCC unit operates with an SO₂ capture efficiency greater than 99%. As a result, SO₂ emissions are consistently below 0.1 lb/10⁶ Btu of coal input, reaching as low as 0.03 lb/10⁶ Btu. Moreover, the process transforms sulfur-based pollutants into 99.99% pure sulfur, a highly valued by-product, rather than a solid waste.

Moisturizing the syngas in combination with steam injection reduced NO_x emissions to the 0.15 lb/10⁶ Btu requirement established by EPA for existing plants in ozone non-attainment areas. Because of the extreme particulate filtration necessary for combustion of the syngas in a gas turbine, particulate emissions were negligible, averaging

Exhibit 3-45
Wabash Thermal Performance Summary

	Design	Actual	
		Coal	Petcoke
Nominal Throughput, tons/day	2,550	2,450	2,000
Syngas Capacity, 10 ⁶ Btu/hr	1,780	1,690	1,690
Combustion Turbine, MWe	192	192	192
Steam Turbine, MWe	105	96	96
Auxiliary Power, MWe	35	36	36
Net Generation, MWe	262	261	261
Plant Efficiency, % (HHV)	37.8	39.7	40.2
Sulfur Removal Efficiency, %	>98	>99	>99

0.012 lb/10⁶ Btu. Also, carbon monoxide emissions were quite low, averaging 0.05 lb/10⁶ Btu.

The ash component of the coal results in a low-carbon vitreous slag, impervious to leaching and valued as an aggregate in construction or as grit for abrasives and roofing materials. Also, the trace metal constituents in the petcoke were effectively captured in the slag produced.

Economic Performance

The overall cost of the IGCC demonstration plant was \$417 million, which equates to about \$1,590/kW in 1994 dollars. For an equivalent greenfield project, allowing for additional new equipment required, the installed cost was estimated at \$1,700/kW. Costs include engineering, permitting, equipment procurement, project and construction management, construction, start-up, and hiring and training personnel.

In the final report, the participant estimates capital cost for a new 262-MWe greenfield IGCC plant incorporating lessons learned, technology improvements, and a heat rate of 8,250 Btu/kWh are \$1,275/kW (2000\$) for a coal-fueled unit and \$1,150/kW (2000\$) for a petroleum coke-

fueled unit. In designing for petcoke, some equipment can be reduced in size and some eliminated.

More recent data developed by DOE shows that a 285-MWe (net) coal-fired greenfield IGCC plant with a heat rate of 8,526 Btu/kWh would cost \$1,318/kW (2000\$). A 291-MWe (net) petroleum coke-fired IGCC unit with a 8,400 Btu/kWh heat rate would cost \$1,260/kW.

Annual fuel costs for the Wabash project ranged from \$15.3–19.2 million, with an annual availability of 75% and using high-sulfur bituminous coal ranging from \$1.00–1.25/10⁶ Btu (\$22–27/ton). Non-fuel operation and maintenance (O&M) costs for the syngas facility (excluding the power block) was 6.8% of installed capital based on 75% availability. O&M costs include operating labor and benefits, technical and administrative support on and off site, all maintenance, chemicals, waste disposal, operating services, supplies, and 5% of the total O&M cost for betterments. Projected O&M costs for a mature IGCC facility (including the power block) are 5.2% of installed capital.

Commercial Applications

At the end of the demonstration in December 1999, Global Energy, Inc. purchased Dynegy's gasification assets and technology. Global Energy is marketing the technology under the name "E-Gas Technology™." The project is continuing to operate in commercial service as Wabash River Energy, Ltd., a subsidiary of Global Energy.

The immediate future for E-Gas Technology™ appears to lie with both foreign and domestic applications where low-cost feedstocks such as petroleum coke can be used and co-production options are afforded—bundled production of steam, fuels/chemicals, and electricity. Integration or association with refinery operations are examples. Factors favoring increased use of IGCC over time are continued improvement in IGCC cost and performance, projected increases in price differentials between coal and gas, and continued importance placed on displacement of petroleum in chemicals and fuels production.

Contacts

Phil Amick, Technology Director—Gasification
(281) 293-2724
ConocoPhillips
Houston, TX
amickpr@conocophillips.com

Victor K. Der, DOE/HQ, (301) 903-2700
victor.der@hq.doe.gov

Leo E. Makovsky, NETL, (412) 386-5814
leo.makovsky@netl.doe.gov

References

Wabash River Coal Gasification Repowering Project: Final Technical Report. Wabash River Coal Gasification Project Joint Venture. August 2000.

Wabash River Coal Gasification Repowering Project—Project Performance Summary. U.S. Department of Energy. January 2002.

Exhibit 3-46
Wabash River Coal Gasification Repowering Project
Production Statistics

Time Period	On Coal (Hr)	Coal Processed (tons)	On Spec. Gas (10 ⁶ Btu)	Steam Produced (10 ⁶ lb)	Power Produced (MWh)	Sulfur Produced (tons)
Start-up 1995	505	41,000 ^a	230,784	171,613	71,000 ^a	559
1996	1,902	184,382	2,769,685	820,624	449,919	3,299
1997	3,885	392,822	6,232,545	1,720,229	1,086,877	8,521
1998	5,279	561,495	8,844,902	2,190,393	1,513,629	12,452
1999 ^b	3,496	369,862	5,813,151	1,480,908	1,003,853	8,557
Overall	15,067	1,549,561	23,891,067	6,383,767	4,125,278	33,388

^aEstimates.
^bThe combustion turbine was unavailable from 3/14/99 through 6/22/99.

Advanced Electric Power Generation

Advanced Combustion/Heat Engines

Healy Clean Coal Project

Project completed

Participant

Alaska Industrial Development and Export Authority

Additional Team Members

Golden Valley Electric Association, Inc.—host and operator

Stone and Webster Engineering Corp.—engineer

TRW, Inc., Space & Technology Division—combustor technology supplier

The Babcock & Wilcox Company (B&W)—spray dryer absorber technology supplier

Usibelli Coal Mine, Inc.—coal supplier

Steigers Corporation—environmental and permitting support

Location

Healy, Denali Borough, AK (adjacent to Healy Unit No. 1)

Technology

TRW's Clean Coal Combustion System; Babcock & Wilcox's spray dryer absorber (SDA) with sorbent recycle

Plant Capacity/Production

50 MWe (nominal)

Coal

Usibelli subbituminous 50% run-of-mine (ROM) coal and 50% waste coal

Project Funding

Total	\$242,058,000	100%
DOE	117,327,000	48
Participant	124,731,000	52

Project Objective

To demonstrate an innovative new power plant design featuring integration of an advanced combustor coupled with both high- and low-temperature emissions control processes.

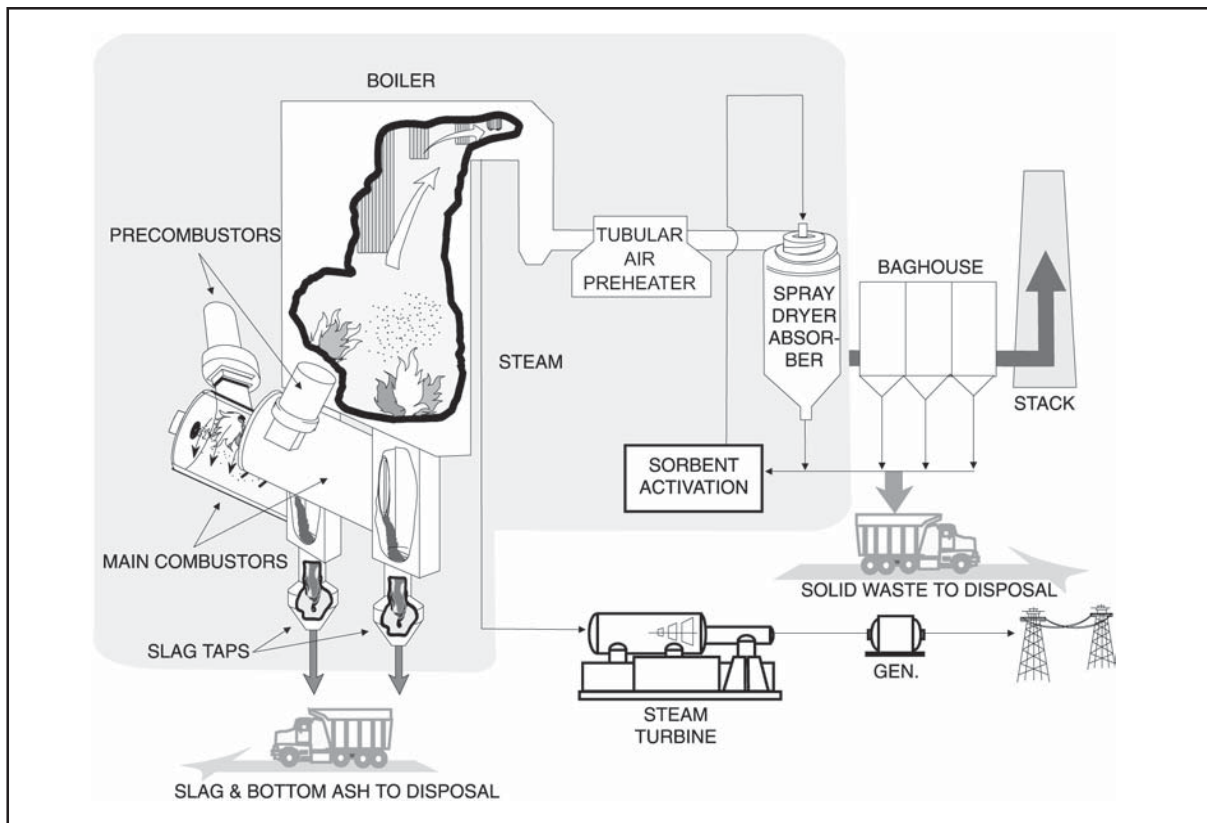

Technology/Project Description

Emissions are controlled using TRW's clean coal combustion system, an advanced entrained/slugging combustors through staged fuel and air injection for NO_x control and limestone injection for SO₂ control. Additional SO₂ is removed using B&W's activated recycle SDA.

A coal-fired precombustor increases the air inlet temperature for optimum slugging performance. The slugging combustors are bottom mounted, injecting the combustion products into the boiler. The main slugging combustor consists of a water-cooled cylinder that slopes toward a slag opening. The precombustor burns 25–40% of the total coal input. The remaining coal is injected axially into the combustor, rapidly entrained by the swirling precombustor gases and additional air flow, and burned under substoichiometric conditions for NO_x control. The ash forms molten slag, which flows along the water-cooled

walls and is driven by aerodynamic and gravitational forces through a slot into the slag recovery section. About 70–80% of the ash is removed as molten slag. The hot gas is then ducted to the furnace where, to ensure complete combustion, additional air is supplied from a tertiary air windbox to NO_x ports and to final overfire air ports. Pulverized limestone (CaCO₃) for SO₂ control is fed into the combustors where it is flash calcined (converting CaCO₃ to lime (CaO)). The mixture of this CaO and ash that was not removed in the combustor, called flash-calcined material, is removed in the fabric filter system. Most of the flash-calcined material is used to form a 45% solids slurry, which is injected into the spray dryer. The SO₂ in the flue gas reacts with the slurry droplets as water is simultaneously evaporated. The SO₂ is further removed from the flue gas by reacting with the dry flash-calcined material on the baghouse filter bags.

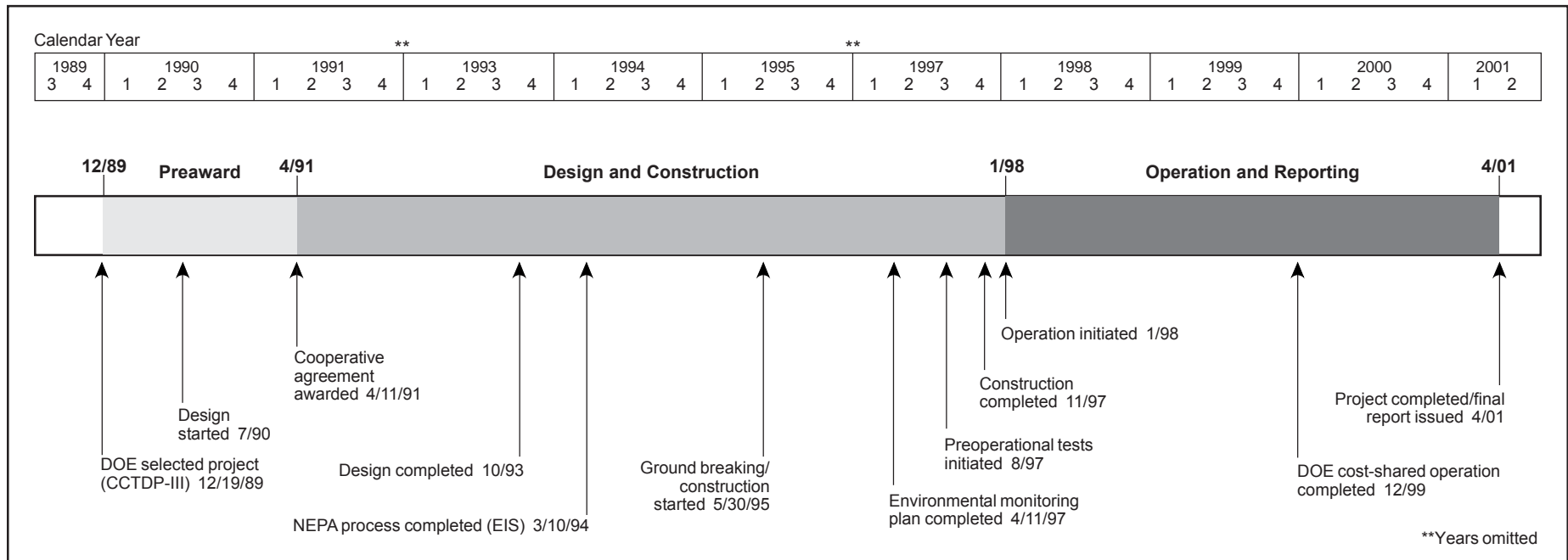

Results Summary

Environmental

- NO_x emissions ranged from 0.208–0.278 lb/10⁶ Btu, with typical emissions of 0.245 lb/10⁶ Btu on a 30-day rolling average, which is well below the permit limit of 0.350 lb/10⁶ Btu on a rolling day average.
- SO₂ emissions were consistently less than 0.09 lb/10⁶ Btu, with typical emissions of 0.038 lb/10⁶ Btu, which are below the permit limit of 0.10 lb/10⁶ Btu (3-hour average).
- High SO₂ removal efficiencies in excess of 90% were achieved with low-sulfur coal and Ca/S molar ratios of 1.4–1.8.
- Particulate matter (PM) emissions were 0.0047 lb/10⁶ Btu, which is well below the permit limit of 0.02 lb/10⁶ Btu.
- CO emissions were less than 130 ppm at 3.0% O₂, with typical emissions of 20–50 ppm at 3.0% O₂, which is well below the permit limit of 202 ppm at 3.0% O₂.

- Tests showed that the SDA system SO₂ emissions, PM emissions, and opacity were well within guarantees of the technology supplier.

Operational

- Carbon burnout goals for the technology supplier were achieved—greater than 99% carbon burnout at 100% maximum continuous rating (MCR) for the ROM, 50/50 blend of ROM/waste coal, and 55/45 blend. The carbon burnout was typically 99.7%.
- The contract goal of the technology supplier for slag recovery greater than 70% at 100% MCR for all coals was also achieved. Slag recovery ranged from 78–87%, with a typical recovery of 83%.
- During a 90-day test in the second half of 1999, the plant availability was 97% at a capacity factor of 95%.
- The SDA pressure drops and power consumption were well below guarantee levels of the technology supplier.
- The system required less limestone and produced less solid waste by-product than anticipated.

Economic

- The capital costs of a 50-MWe and 300-MWe plant using this system are \$90.6 million (\$1,812/kW) and \$450.7 million (\$1,502/kW) (1993\$), respectively.
- The variable operating costs for the 300-MWe system is \$7.2 million/yr (1993\$) for the fixed cost and \$28.4 million/yr (1993\$) for the variable costs (based on 90% capacity factor).
- The levelized cost of power is 36.5 mills/kWh (constant 1993\$) for the 300-MWe plant (based on 90% capacity factor).
- The levelized cost per ton of SO₂/NO_x removed is \$6,499/ton (constant 1993\$) for the 300-MWe plant (based on 90% capacity factor).

Project Summary

The Healy Clean Coal Project is the first utility-scale demonstration of the TRW clean coal combustion system. The project site is adjacent to the existing Healy Unit No. 1 near Healy, Alaska and the Usibelli coal mine. Power is supplied to the Golden Valley Electric Association (GVEA).

Environmental Performance

The entrained/slugging combustor is designed to minimize NO_x emissions, achieve high carbon burnout, and remove the majority of fly ash from the flue gas prior to the boiler. The slugging combustor is also the first step of a three-step process for controlling SO₂ by first converting limestone to flash-calcined lime. Second, the flash calcined-lime absorbs SO₂ within the boiler. Third, the majority of the SO₂ is removed with B&W's SDA system,

which uses the flash-calcined lime and fly ash captured in the baghouse. Because most of the coal ash is removed by the slugging combustors, the recycled material is rich enough in calcium content that the SDA can be operated solely on the recycled solids, eliminating the need to purchase or manufacture lime for the back end scrubbing system.

During a cumulative six-month combustion system characterization test, a series of tests were performed to establish baseline performance of the combustion system while burning ROM and ROM/waste coal blends, to map combustor performance characteristics over a broad range of operating conditions and hardware configurations, and to determine the best configuration and operating conditions for long-term operation. During the 24-month demonstration test period, the NO_x, SO₂, PM, opacity, and CO emission goals were met with the exception of short-term SO₂

and opacity exceed-ances during start-up and repairs. The emissions, as well as permit and NSPS requirements, are presented in Exhibit 3-47.

Performance testing of the SDA system conducted in June 1999 showed that the technology performed well. Measurements of the SDA inlet, SDA outlet, stack, limestone feed, coal feed, air preheater hopper ash, surge bin ash, electrical power consumption, and stack opacity, as well as normal plant data from the plant distributed control system, showed that the technology exceeds the guarantees. The results of the tests and the performance guarantees are shown in Exhibit 3-48. It should be noted that environmental performance was not fully optimized.

Exhibit 3-47
Healy Performance Goals and Demonstration Test Program Results
(January 1998–December 1999)

Parameter	NSPS	Permit	Goal	Actual Range	Actual Typical
NO _x	0.5 lb/10 ⁶ Btu (new plant after 7/97)	0.350 lb/10 ⁶ Btu (30-day rolling avg) 1,010 tons/yr (full load)	0.20–0.35 lb/10 ⁶ Btu (30-day rolling avg)	0.208–0.278 lb/10 ⁶ Btu (30-day rolling avg)	0.245 lb/10 ⁶ Btu (30-day rolling avg)
SO ₂	70% removal with emissions <0.60 lb/10 ⁶ Btu	0.086 lb/10 ⁶ Btu (annual avg) 0.10 lb/10 ⁶ Btu (3-hour avg) 65.8 lb/hr max (3-hour avg) 248 tons/yr (full load)	70% removal (minimum) 79.6 lb/hr max (3-hour avg)	~90% removal <0.09 lb/10 ⁶ Btu (30-minute avg corrected to 3% O ₂)	0.038 lb/10 ⁶ Btu (30-minute avg corrected to 3% O ₂)
PM	0.03 lb/10 ⁶ Btu 99% reduction	0.020 lb/10 ⁶ Btu (hourly avg) 13.2 lb/hr (hourly avg) 58 tons/yr (full load)	0.015 lb/10 ⁶ Btu (hourly avg)	NA	0.0047 lb/10 ⁶ Btu ^b
Opacity	20% Opacity (6-minute avg)	20% Opacity (3-minute avg) 27% Opacity (one 6-minute period per hour)	20% Opacity (3- minute avg)	2–6% Opacity (30-minute avg)	3.9% Opacity ^a (30-minute avg)
CO	Dependent on ambient CO levels in the local region	0.20 lb/10 ⁶ Btu (hourly avg) 202 ppm (corrected to 3% O ₂) 132 lb/hr, 577 tons/yr (full load)	206 ppm (corrected to 3.0% O ₂) 200 ppm (corrected to 3.5% O ₂)	20–50 ppm (30-minute avg corrected to 3% O ₂)	25.9 ppm (30-minute avg corrected to 3% O ₂)

^a Measured 2.3% after correction of problems with premature filter bag failures in the baghouse.

^b Not measured during demonstration test program. Data are from source test in March 1999.

Operational Performance

The slagging stage of the combustor performed extremely well and continuously demonstrated the capability to burn both ROM and ROM/waste coal blends over a broad range of operating conditions. The precombustor performed very well with ROM coal, but exhibited more variable performance, in terms of slagging behavior, during the initial tests with ROM/waste coal blends.

Localized slag freezing was observed in the precombustor during early testing. A combination of hardware configuration and operational configuration changes were made that minimized slag freezing. These changes included relocating the secondary air from the precombustor mix annulus to the head end of the slagging stage and completely transferring the precombustor mill air to the boiler NO_x ports following boiler warmup. These changes eliminated the mixing of excess air downstream of the precombustor chamber to minimize local slag freezing and increased the precombustor operating temperature to provide additional temperature margin. The mill air change had the added benefit of simplifying combustor operation by eliminating the need to monitor and control coal-laden mill air flow to the precombustor mill air ports during steady-state operation.

Testing of the slagging combustor also showed that the contract goals were achieved, which included greater than 99% carbon burnout at 100% maximum continuous rating

(MCR) for the performance, ROM, 50/50 blend of ROM/waste coal, and 55/45 blend; and greater than 98% carbon burnout at 100% MCR for waste coal. The carbon burnout was typically 99.7%. Slag recovery ranged from 78–87%, with a typical reading of 83%, easily meeting the contract goal for slag recovery of greater than 70% at 100% MCR for all coals.

The SDA system also performed well. During performance testing in June 1999, system pressure drops were well below the 13 inches water gage (in. w.g.) guarantee. The range was 9.6–10.0 in. w.g. as can be seen in Exhibit 3-48. Power consumption was approximately 38–41% less than the guaranteed level. Based on these results, Stone & Webster concluded that the SDA system met all performance guarantees.

Economic Performance

Capital and operating cost estimates were prepared by an independent consultant to the participant for new plants in the “lower 48” that incorporate the technology demonstrated at Healy. The capital costs for a 50-MWe and 300-MWe plant are \$90.6 million (1,812 \$/kW) and \$450.7 million (1,502 \$/kW) (1993\$), respectively. The variable operating cost for the 300-MWe plant is estimated at \$7.2 million per year and the fixed operating costs are estimated at \$28.4 million per year based on a 90 percent capacity factor (1993\$). The levelized cost of power would then be

36.5 mills/kWh (constant 1993\$). The levelized cost per ton of SO₂ and NO_x removed is \$6,499/ton (constant 1993\$) for the 300-MWe plant.

Commercial Applications

This technology is appropriate for any size utility or industrial boiler in new or retrofit uses. It can be used in coal-fired boilers as well as in oil- and gas-fired boilers because of its high ash-removal capability. However, cyclone boilers may be the most amenable type to retrofit with the entrained/slagging combustor because of the limited supply of high-Btu, low-sulfur, low-ash-fusion-temperature coal that cyclone boilers require. The commercial availability of cost-effective and reliable systems for SO₂, NO_x, and particulate control is important to potential users planning new capacity, repowering, or retrofits to existing capacity in order to comply with CAAA requirements.

Contacts

Arthur E. Copoulos, Project Manager, (907) 269-3029
Alaska Industrial Development and Export Authority
813 West Northern Lights Blvd
Anchorage, AK 99503
(907) 269-3044 (fax)
acopoulos@aidea.org

Victor K. Der, DOE/HQ, (301) 903-2700
victor.der@hq.doe.gov

Robert M. Kornosky, NETL, (412) 386-4521
robert.kornosky@netl.doe.gov

References

Healy Clean Coal Project—Project Performance and Economics Report Final Report: Volume 2. AIDEA. April 2001.

Spray Dryer Absorber System Performance Test Report: June 7-11, 1999. Stone & Webster Engineering Corporation. February 2000.

Exhibit 3-48		
Healy SDA Performance Test Results and Performance Guarantees		
Operating Parameter	Guarantee	Range of Parameter Values
SO ₂	79.6 lb/hr (max)	<2.15
PM	0.015 lb/10 ⁶ Btu	0.0014-0.0052
Opacity	20% Opacity (3-minute avg) 27% Opacity for 3 minutes per hour	1.0-2.0
System Pressure Drop	13 in. w.g.	9.6-10.0
System Power Consumption	550.5 kW	324-340

Coal Processing for Clean Fuels

Commercial-Scale Demonstration of the Liquid Phase Methanol (LPMEOH™) Process

Participant

Air Products Liquid Phase Conversion Company, L.P. (a limited partnership between Air Products and Chemicals, Inc., the general partner, and Eastman Chemical Company)

Additional Team Members

Air Products and Chemicals, Inc.—technology supplier and cofunder

Eastman Chemical Company—host, operator, synthesis gas and services provider

ARCADIS Geraghty & Miller—fuel methanol tester and cofunder

Location

Kingsport, Sullivan County, TN (Eastman Chemical Company's Chemicals-from-Coal Complex)

Technology

Air Products and Chemicals, Inc.'s LPMEOH™ process

Plant Capacity/Production

80,000 gallons/day of methanol (nominal)

Coal

Eastern high-sulfur bituminous, 3–5% sulfur

Project Funding

Total	\$213,700,000	100%
DOE	92,708,370	43
Participant	120,991,630	57

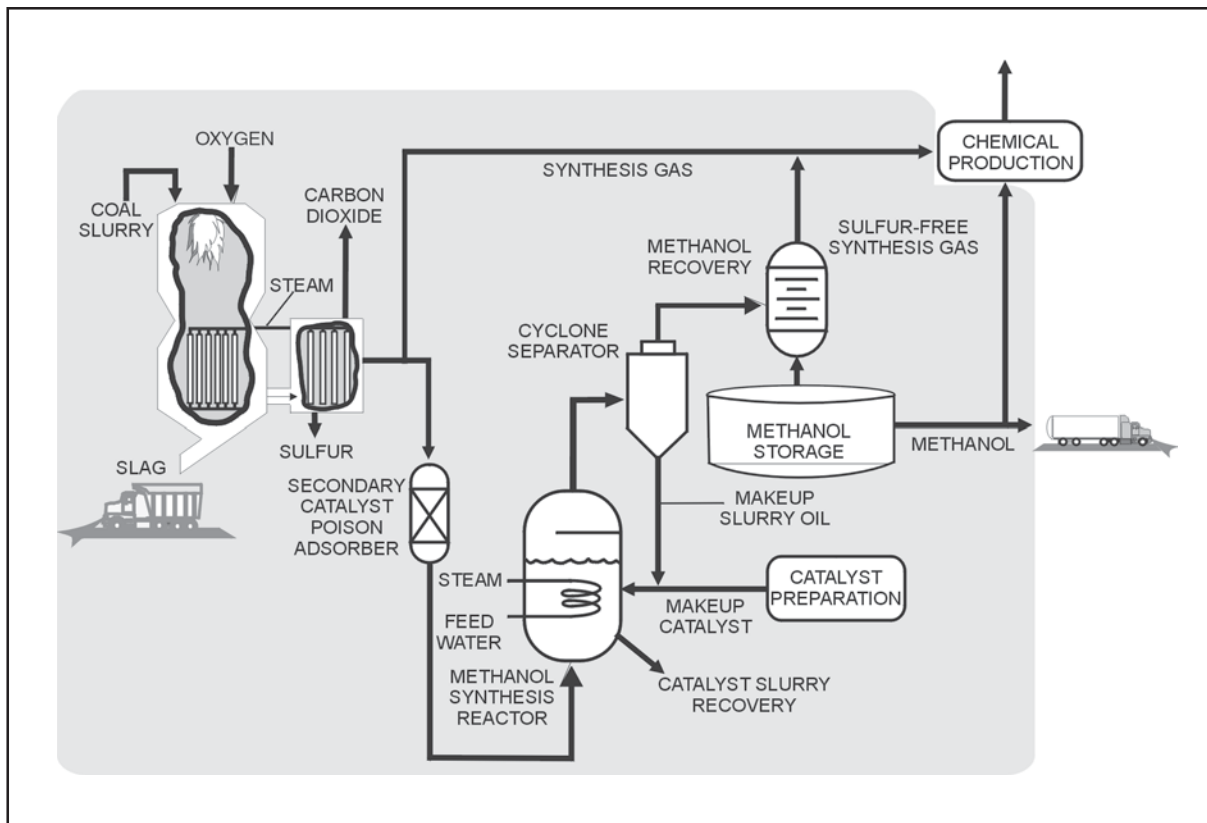

Project Objective

To demonstrate on a commercial scale the production of methanol from coal-derived synthesis gas using the LPMEOH™ process; to determine the suitability of methanol produced during this demonstration for use as a chemical feedstock or as a low-SO_x emitting, low-NO_x emitting alternative fuel in stationary and transportation applications; and to demonstrate, if practical, the production of dimethyl ether (DME) as a mixed co-product with methanol.

Technology/Project Description

This project has completed the demonstration, at commercial scale, of the LPMEOH™ process to produce methanol from coal-derived synthesis gas. The combined reactor and heat removal system is different from other commercial methanol processes. The liquid phase not only

suspends the catalyst but functions as an efficient means to remove the heat of reaction away from the catalyst surface. This feature permits the direct use of synthesis gas streams as feed to the reactor without the need for water-gas shift conversion. Synthesis gas feed to the LPMEOH™ reactor is produced by the gasification of eastern high-sulfur bituminous coal (Mason seam) containing 3% sulfur (5% maximum) and 10% ash.

Methanol fuel testing was conducted in off-site stationary and mobile applications, such as fuel cells, buses, and distributed electric power generation. Stabilized methanol from the project was made available to several test locations to study the feasibility of using the product as a feedstock in transportation and power generation applications.

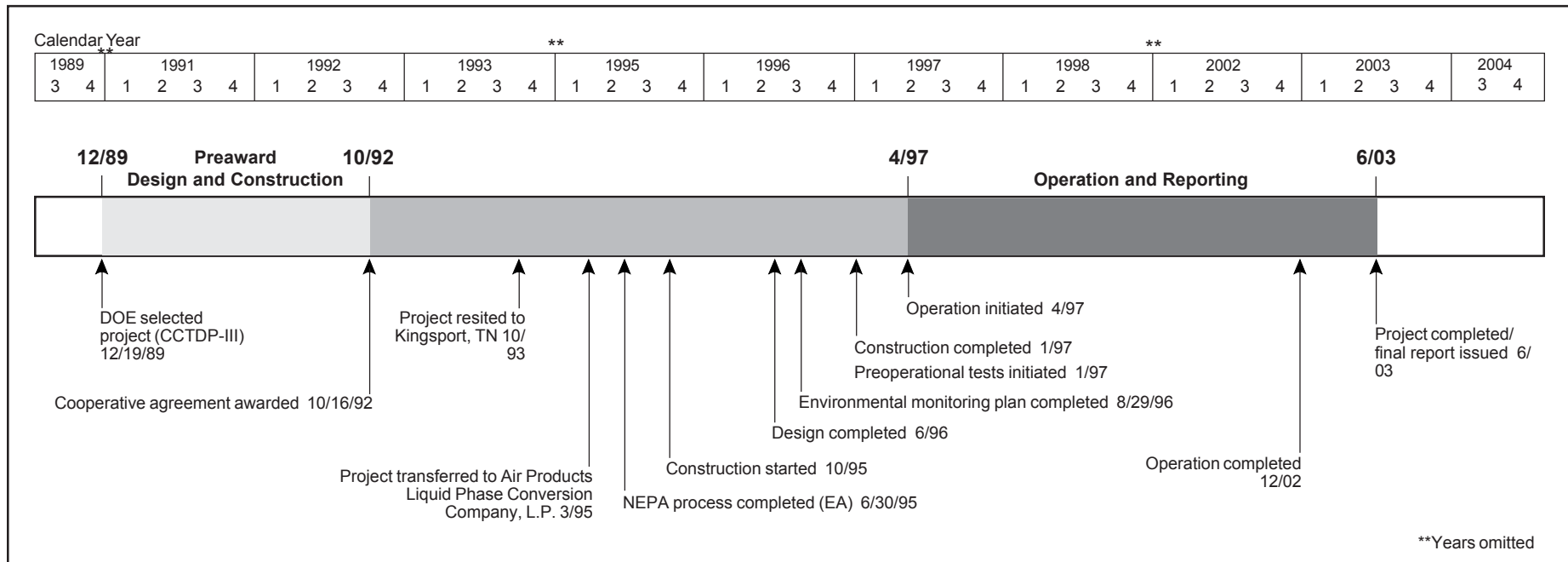

Results Summary

Environmental

- Stabilized methanol from the LPMEOH™ process has less than 1% of water by weight, is free of sulfur, and can potentially be used directly in transportation and power applications.
- Stabilized methanol produced from the LPMEOH™ demonstration unit has been tested in bus and flexible fuel vehicles. Results show that methanol produced from the process provides the same environmental benefits as chemical-grade methanol with no penalty on fuel economy or performance.
- Diesel generator and gas turbine tests show that levels of NO_x in exhaust air can be lowered when stabilized methanol or methanol-oil-water emulsions are used instead of conventional oil fuels.

Operational

- During the 69-month demonstration test program, the LPMEOH™ test unit had an overall availability of 97.5% with the longest operating run without interruption at 94 days.

- Over 103.9 million gallons of methanol were produced from the facility and accepted by Eastman Chemical Company for use in the production of methyl acetate. Methanol from the project was shipped to seven test locations to study the feasibility of its use in power and transportation applications.
- Nameplate production capacity of 80,000 gallons per day for the demonstration unit was achieved within four days of start-up, and production rates exceeding 115% of design capacity were achieved within six days.
- Investigations during the LPMEOH™ demonstration project were able to improve the long-term performance of the methanol synthesis catalyst. The average rate of catalyst deactivation during one six-month period was 0.17% per day, which is one-half of the original design basis, based on earlier proof-of-concept tests.
- In either baseload or cycling operation, partial conversion of between 20% and 33% of the syngas is economically optimal and conversion approaching 50% is feasible.

- Commercial viability of the Liquid Phase Dimethyl Ether (LPDME™) process was demonstrated on a 10 short ton per day scale using commercially produced catalysts.
- The deactivation rate for both the methanol synthesis and dehydration catalysts used in the LPDME™ process was 0.7% per day, which was lower than the 1.2% per day rate calculated during autoclave experiments.

Economic

- The capital cost of a 500 short ton per day LPMEOH™ plant that coproduces fuel-grade methanol in a coal-based IGCC plant was estimated to be \$31.08 million.
- Economic studies show that the price of methanol coproduced in an IGCC power plant can be less than \$0.50 per gallon.

Project Summary

The LPMEOH™ process accomplished the objectives set out in the cooperative agreement. The demonstration unit produced over 103.9 million gallons of methanol, operating at 97.5% availability. Originally developed to enhance electrical power generation using IGCC technology, the LPMEOH™ process is ideally suited for directly processing gases produced by modern coal gasifiers. The LPMEOH™ technology provides several improvements essential for the economic co-production of methanol and electricity directly from gasified coal. The liquid phase process suspends fine catalyst particles in an inert liquid, forming a slurry. The slurry dissipates the heat of the chemical reaction away from the catalyst surface, protecting the catalyst, and allowing the methanol synthesis reaction to proceed at higher rates.

Operational Performance

Operations began on April 2, 1997 and nameplate production capacity of 80,000 gallons per day was reached within four days. Production rates exceeding 115% of the design level were achieved within six days.

During the performance period, ideas to reduce the capital cost of future plants were implemented. The use of gravity to return entrained catalyst slurry and condensed process oil from downstream equipment back to the LPMEOH™ reactor was successfully demonstrated, and it eliminated the need for expensive slurry pumps within the synthesis loop. A new, *in situ* catalyst activation procedure was also developed. Previously, catalyst was activated in small quantities and transferred to the LPMEOH™ reactor. *In situ* activation involved charging the reactor with fresh catalyst and activating it at one time. The first *in situ* activation study began on August 24, 2001 and was completed on June 4, 2002. Additionally, “temperature programming” was used during this demonstration to improve catalyst performance. Temperature programming is the technique of initially operating at low temperatures and slowly increasing the temperature with time to maintain constant production of methanol and extend the life of the catalyst. The average catalyst deactivation rate for this demonstration was similar to earlier results.

A second, six-month, *in situ* activation study began on June 28, 2002. This study was similar to the first *in situ* activation study except that the procedure was revised to eliminate the storage of unreduced catalyst slurry at elevated temperatures. The average rate of catalyst deactivation during this study was 0.17% per day, which was about one-half of the design basis and lower than earlier results.

The LPMEOH™ demonstration project also focused on the impact of trace contaminants in coal-derived synthesis gas on catalyst performance and lifetime. The catalyst guard bed was changed to a new material that is expected to reduce catalyst poisons such as arsenic. This new adsorbent is an activated carbon impregnated with copper oxide. Typically, fresh adsorbent can be used for about



The LPMEOH™ plant continues in commercial operation at Eastman Chemical Company.

two months before breakthrough of arsine at the LPMEOH™ demonstration unit. However, a thermal treatment was employed which extended the service life of the adsorbent by an additional two months.

Methanol product-use testing was conducted on-site and off-site. The on-site product-use testing involved constant monitoring of the refined-grade methanol according to a set of Eastman Chemical fitness-for-use criteria. Occasionally, a tank lot sample failed to meet the criteria, but the lot could be accepted on a case-by-case basis if there was no impact once the lot in question was mixed in the primary methanol storage tank. Through the end of December 1997, a total of 24 lots were accepted in this manner. Eastman Chemical accepted all of the available methanol for use in the production of methyl acetate, and ultimately cellulose acetate and acetic acid.

Off-site product testing consisted of transportation systems and power generation systems. Three vehicles at the Florida Institute of Technology were used to test methanol and methanol blends for bus and light-duty vehicles. Testing was limited, but no major problems were reported. Another set of tests at ARCADIS Geraghty & Miller showed methanol blends from the LPMEOH™ process exhibited similar performance for both fuel economy and emissions as when operated on fuel blends either stabilized methanol or chemical-grade methanol. West Virginia University (WVU) also tested three buses operation on methanol. On average, hydrocarbon (primarily unburned methanol and aldehydes) and particulate matter emissions were slightly higher than when chemical-grade methanol was used.

Power generation testing using stabilized methanol was conducted by WVU on an aircraft gas turbine, by ARCADIS on a U.S. Air Force aircraft ground support diesel generator, by ARCADIS on a low-NO_x stationary microturbine combustor, and by the University of Florida on a fuel cell. All of the test results were promising.

The LPMEOH™ project team performed a process design verification test run of the LPDME™ process to produce DME. The test was conducted at a pilot scale of 10 short tons per day at the LaPorte, Texas, Alternative Fuels Development Unit (AFDU). The plant was operated for 25 days using commercially produced catalysts to obtain

scale-up information and to compare catalyst aging compared to laboratory results. The deactivation rate for both LPDME™ catalysts during the pilot scale test was 0.7%, which was an improvement over the 1.2% rate calculated during laboratory experiments.

Environmental Performance

Methanol produced from the LPMEOH™ process offers several advantages. It is a stabilized product that contains less than one percent of water by weight and is sulfur free, and could potentially be used as a replacement fuel for petroleum in transportation, a peaking fuel in power applications, a chemical feedstock, or as a source of hydrogen for fuel cells. Transportation tests were performed at three different locations on a variety of vehicles and methanol fuel blends. Methanol produced from the LPMEOH™ process showed little difference in vehicle performance when compared to fuels made with chemical-grade methanol. The LPMEOH™ methanol typically formed less NO_x than the chemical-grade methanol blends. Power application tests showed that stabilized methanol and methanol-oil-water emulsions could lower NO_x levels in the exhaust air from gas turbines and diesel engines that operate on conventional oil fuels.

Economic Performance

The economic base case for this project is a 500 short ton per day, LPMEOH™ plant that co-produces fuel-grade methanol in a coal-based IGCC power plant. The estimated capital cost for the LPMEOH™ facility in an IGCC power plant is \$31.08 million. Improvements in catalyst performance, such as *in situ* activation, and temperature programming could provide an additional capital cost reduction of 10%.

Economic analyses show that methanol from the LPMEOH™ process has a cost of less than \$0.50 per gallon when co-produced in an IGCC power plant. As the economics of IGCC technology improve, so will the economics for coproduction of methanol. If the catalyst performance and lifetime improvements over the last six months can be maintained, variable costs for the LPMEOH™ process can be reduced by 25%. When combined with IGCC technology, the LPMEOH™ process can provide a pathway for local communities to

meet their electric power, transportation, and chemical product needs.

Commercial Applications

In commercial U.S. applications, methanol is typically used as a feedstock to produce chemicals such as formaldehyde, methyl tertiary butyl ether (MTBE—a gasoline additive), acetic acid, dimethyl terephthalate, methyl methacrylate, and fuels and solvents. Future markets for methanol could include fuel cell applications. Currently, over 50% of the demand for DME is for use as a projectile agent. However, it is also used as a methylating agent, a laboratory system cleaning material, and in electronics. Future markets could include large-scale power production, substitution for diesel fuel, or as a replacement transportation fuel for liquefied petroleum gas.

Development of the LPMEOH™ process in the United States will depend on several factors, including development and timing of the IGCC industry, improvements in IGCC economics, new environmental regulations affecting coal-based power generation, and other incentives. Outside of the United States, most of the current interest in the LPMEOH™ technology has come from China. China has an abundance of coal and an historical dependence on domestic chemical production, making it a long-term option for use of the LPMEOH™ process.

Contacts

Robert J. Kirkland
Air Products and Chemicals, Inc.
7201 Hamilton Boulevard
Allentown, PA 18195-1501
(610) 481-4866
(610) 706-4811 (fax)
kirkclarj@apci.com

Edward Schmetz, DOE/HQ, (301) 903-3931
edward.schmetz@hq.doe.gov

Robert M. Kornosky, NETL, (412) 386-4521
robert.kornosky@netl.doe.gov

References

Commercial-Scale Demonstration of the Liquid Phase Methanol (LPMEOH™) Process—Final Report. Air Products Liquid Phase Conversion Company, L.P. June 2003.

Topical Report Number 11: Clean Coal Technology—Commercial-Scale Demonstration of the Liquid Phase Methanol (LPMEOH™) Process. U.S. Department of Energy. April 1999.

Development of the Coal Quality Expert™

Project completed

Participants

ABB Combustion Engineering, Inc. and CQ Inc.

Additional Team Members

Black & Veatch—cofounder and software developer

Electric Power Research Institute—cofounder

The Babcock & Wilcox Company—cofounder and pilot-scale tester

Electric Power Technologies, Inc.—field tester

University of North Dakota, Energy and Environmental Research Center—bench-scale tester

Utility Companies—(5 hosts)

Locations

Grand Forks, Grand Forks County, ND (bench tests)

Windsor, Hartford County, CT (bench- and pilot-scale tests)

Alliance, Columbiana County, OH (pilot-scale tests)

Five utility host sites

Technology

CQ Inc.'s EPRI Coal Quality Expert™ (CQE™) computer software

Plant Capacity/Production

Full-scale testing took place at utility sites ranging in size from 250–880 MWe.

Coal

Wide variety of coals and blends

Coal Quality Expert, CQE, CQIS, and CQIM are trademarks of the Electric Power Research Institute.

Pentium is a registered trademark of Intel.

OS/2 Warp is a registered trademark of IBM.

Windows is a registered trademark of Microsoft Corporation.

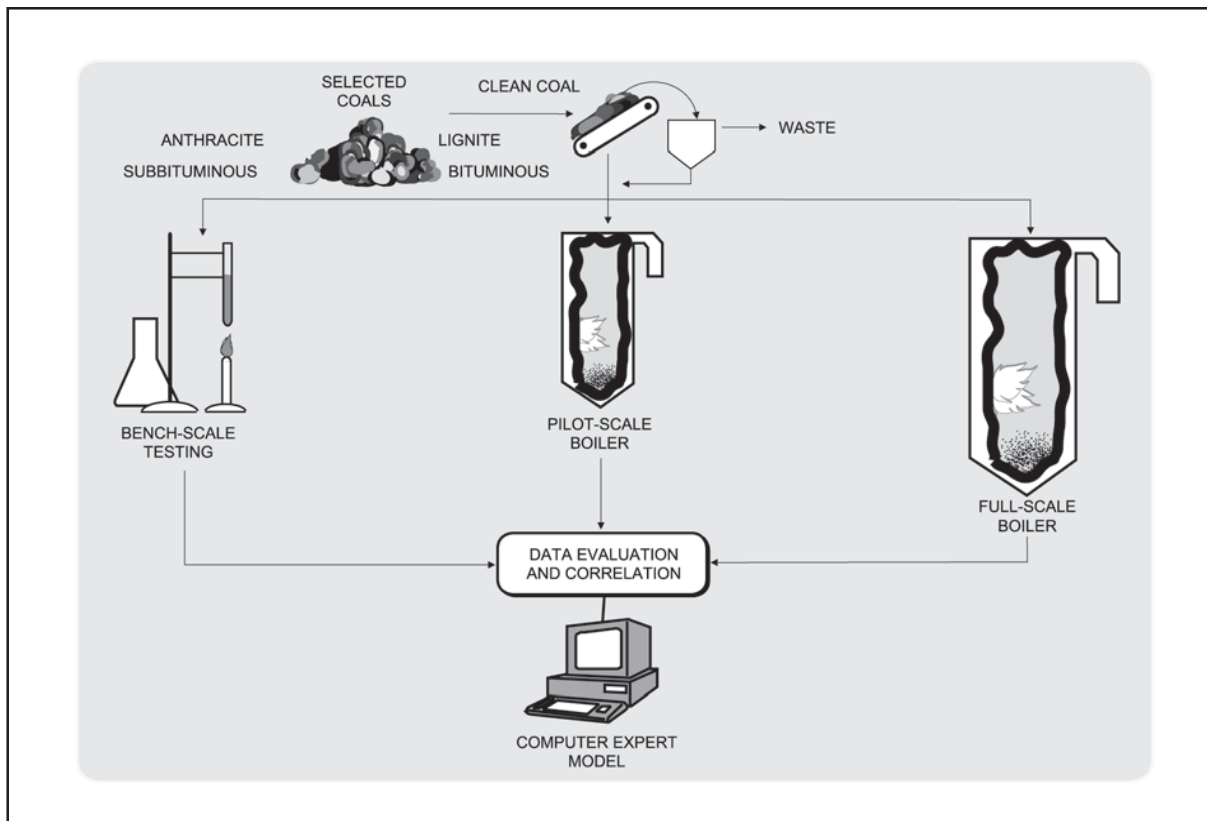

Project Funding

Total	\$21,746,004	100%
DOE	10,863,911	50
Participants	10,882,093	50

Project Objective

The objective of the project was to provide the utility industry with a PC software program it could use to confidently and inexpensively evaluate the potential for coal-cleaning, blending, and switching options to reduce emissions while producing the lowest cost electricity. Specifically the project was to: (1) enhance the existing Coal Quality Information System (CQIS™) database and Coal Quality Impact Model (CQIM™) to allow assessment of the effects of coal-cleaning on specific boiler costs and performance; and (2) develop and validate CQE™, a model that allows accurate and detailed predic-

tion of coal quality impacts on total power plant operating cost and performance.

Technology/Project Description

The CQE™ is a software tool that brings a new level of sophistication to fueling decisions by integrating the system-wide impact of fuel purchase decisions on coal-fired power plant performance, emissions, and power generation costs. The impacts of coal quality; capital improvements; operational changes; and environmental compliance alternatives on power plant emissions, performance, and production costs can be evaluated using CQE™. CQE™ can be used to systematically evaluate all such impacts, or it may be used in modules with some default data to perform more strategic or comparative studies.

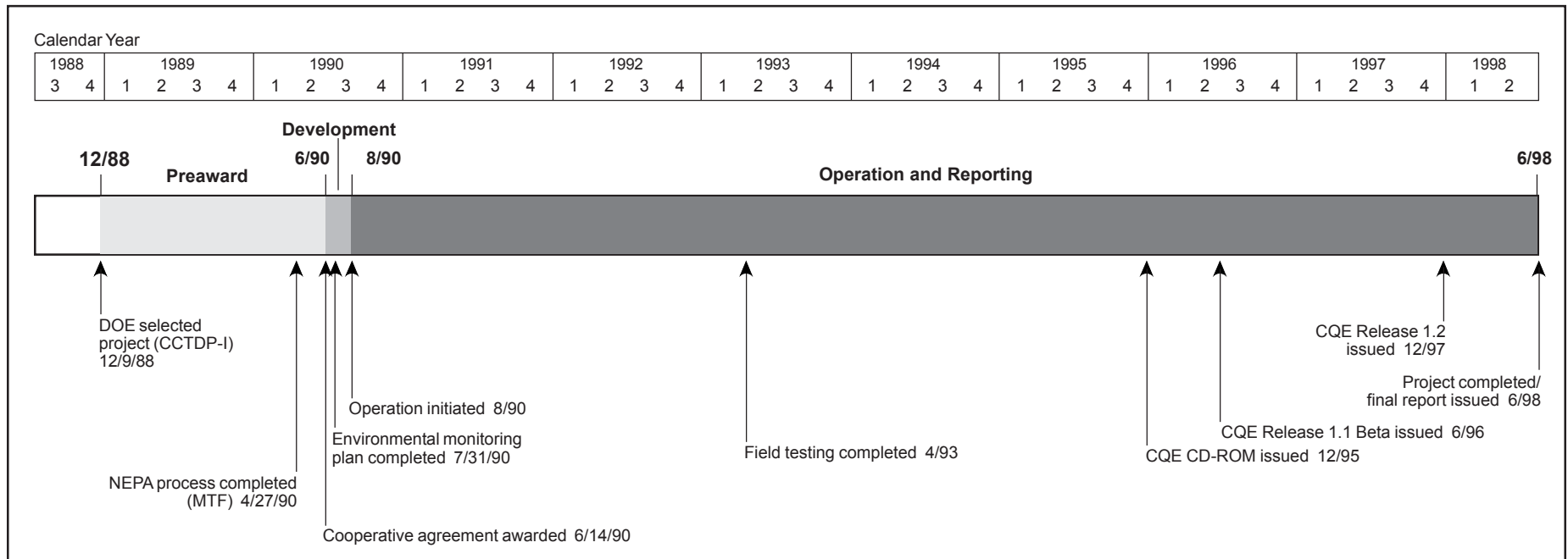

Results Summary

Environmental

- CQE™ includes models to evaluate emission and regulatory issues.

Operational

- CQE™ can be used on a stand-alone computer or as a network application for utilities, coal producers, and equipment manufacturers to perform detailed coal impact analyses.
- Four features included in the CQE™ program are:
 - Fuel Evaluator,
 - Plant Engineer,
 - Environmental Planner, and
 - Coal-Cleaning Expert.
- CQE™ can be used to evaluate:
 - Coal quality,
 - Transportation system options,
 - Performance issues, and
 - Alternative emissions control strategies.

- CQE™ operates on an OS/2 Warp® (Version 3 or later) operating system with preferred hardware requirements of a Pentium®-equipped personal computer, 1 gigabyte hard disk space, 32 megabytes RAM, 1024x768 SVGA, and CD-ROM.

Economic

- CQE™ includes economic models to determine production cost components for coal-cleaning processes, power production equipment, and emissions control systems.

Project Summary

CQETM began with EPRI's CQIMTM, developed for EPRI by Black & Veatch and introduced in 1989. CQIMTM was endowed with a variety of capabilities, including evaluating Clean Air Act compliance strategies, evaluating bids on coal contracts, conducting test-burn planning and analysis, and providing technical and economic analyses of plant operating strategies. CQETM, which combines CQIMTM with other existing software and databases, extends the art of model-based fuel evaluation established by CQIMTM in three dimensions: (1) new flexibility and application, (2) advanced technical models and performance correlations, and (3) advanced user interface and network awareness.

Operational Performance

Algorithm Development. Data derived from bench-, pilot-, and full-scale testing were used to develop the CQETM algorithms. Bench-scale testing was performed at ABB Combustion Engineering's facilities in Windsor, Connecticut and the University of North Dakota's Energy and Environmental Research Center in Grand Forks, North Dakota. Pilot-scale testing was performed at ABB Combustion Engineering's facilities in Windsor, Connecticut and Alliance, Ohio. The five field test sites were:

- Alabama Power's Gatson, Unit No. 5 (880 MWe), Wilsonville, Alabama;
- Mississippi Power's Watson, Unit No. 4 (250 MWe), Gulfport, Mississippi;
- New England Power's Brayton Point, Unit No. 2 (285 MWe) and Unit No. 3 (615 MWe), Somerset, Massachusetts;
- Northern States Power's King Station (560 MWe), Bayport, Minnesota; and
- Public Service Company of Oklahoma's Northeastern, Unit No. 4 (445 MWe), Oologah, Oklahoma.

The six large-scale field tests consisted of burning a baseline coal and an alternate coal over a two-month period. The baseline coal was used to characterize the operating performance of the boiler. The alternate coal, a blended or cleaned coal of improved quality, was burned in the boiler for the remaining test period.

The baseline and alternate coals for each test site also were burned in bench- and pilot-scale facilities under similar conditions. The alternate coal was cleaned at CQ Inc. to determine what quality levels of clean coal can be produced economically and then transported to the bench- and pilot-scale facilities for testing. All data from bench-, pilot-, and full-scale facilities were evaluated and correlated to formulate algorithms used to develop the model.

CQETM Capability. The OS/2®-based program evaluates coal quality, transportation system options, performance issues, and alternative emissions control strategies for utility power plants. CQETM is composed of technical tools to evaluate performance issues, environmental models to evaluate emissions and regulatory issues, and economic models to determine production cost components. These include consumables (e.g., fuel, scrubber additives), waste disposal, operation and maintenance, replacement energy costs, and operation and maintenance costs for coal-cleaning processes, power production equipment, and emissions control systems. CQETM has four main features:

- Fuel Evaluator—Performs system-, plant-, or unit-level fuel quality, economic, and technical assessments.
- Plant Engineer—Provides in-depth performance evaluations with a more focused scope than provided in the Fuel Evaluator.
- Environmental Planner—Provides access to evaluation and presentation capabilities of the Acid Rain Advisor.
- Coal-Cleaning Expert—Establishes the feasibility of cleaning a coal, determines cleaning processes, and predicts associated costs.

Software Description. The CQETM includes more than 100 algorithms based on the data generated in the six full-scale field tests. The CQETM design philosophy underscores the importance of flexibility by modeling all important power plant equipment and systems and their performance in real-world situations. This level of sophistication allows new applications to be added by assembling a model of how objects interact. Updated information records can be readily shared among all affected users because CQETM is network-aware, enabling users

throughout an organization to share data and results. The CQETM object-oriented design, coupled with an object database management system, allows different views of the same data. As a result, staff efficiency is enhanced when decisions are made.

CQETM also can be expanded without major revisions to the system. Object-oriented programming allows new objects to be added and old objects to be deleted or enhanced easily. For example, if modeling advancements are made with respect to predicting boiler ash deposition (i.e., slagging and fouling), the internal calculations of the object that provides these predictions can be replaced or augmented. Other objects affected by ash deposition (e.g., ash collection and disposal systems, sootblower systems) do not need to be altered; thus, the integrity of the underlying system is maintained.

System Requirements. CQETM uses the OS/2® operating system. CQETM can operate in stand-alone mode on a single computer or on a network. Technical support is available from Black & Veatch for licensed users.

Commercial Applications

The CQETM system is applicable to all electric power generation plants and large industrial/institutional boilers that burn pulverized coal. Potential users include fuel suppliers, environmental organizations, government and regulatory institutions, and engineering firms. International markets for CQETM are being explored by both CQ Inc. and Black & Veatch.

EPRI owns the software and distributes CQETM to EPRI members for their use. CQETM is available to others in the form of three types of licenses: user, consultant, and commercializer. CQ Inc. and Black & Veatch have each signed commercialization agreements, which give both companies non-exclusive worldwide rights to sell user's licenses and to offer consulting services that include the use of CQETM software.

CQETM was recognized in 1996 by the Secretary of Energy and the President of EPRI as the best of nine DOE/EPRI cost-shared utility research and development projects under the "Sustainable Electric Partnership" program.

The CQE™ program has been incorporated in the Vista program package, which is the latest version of the software. Vista operates in the Windows® environment. The Vista Fuels Web server has a Home Page on the World Wide Web (<http://www.fuels.bv.com>) to promote the software, facilitate communications between developers and users, and eventually allow software updates to be distributed over the Internet. The Home Page also helps attract the interest of international utilities and consulting firms.

Contacts

Clark D. Harrison, President, (724) 479-3503

CQ Inc.

160 Quality Center Rd.

Homer City, PA 15748

(724) 479-4181 (fax)

clarkh@cq-inc.com

Douglas Archer, DOE/HQ, (301) 903-9443

douglas.archer@hq.doe.gov

Joseph B. Renk III, NETL, (412) 386-6406

joseph.renk@netl.doe.gov

References

Final Report: Development of a Coal Quality Expert. CQ Inc. June 20, 1998.

“Recent Experience with the CQE™.” Harrison, Clark D. *et al.* *Fifth Annual Clean Coal Technology Conference: Technical Papers.* January 1997.

Comprehensive Report to Congress on the Clean Coal Technology Program: Development of the Coal Quality Expert. ABB Combustion Engineering, Inc., and CQ Inc. Report No. DOE/FE-0174P. U.S. Department of Energy. May 1990. (Available from NTIS as DE90010381.)



Five utilities acted as hosts for field tests of CQE™.

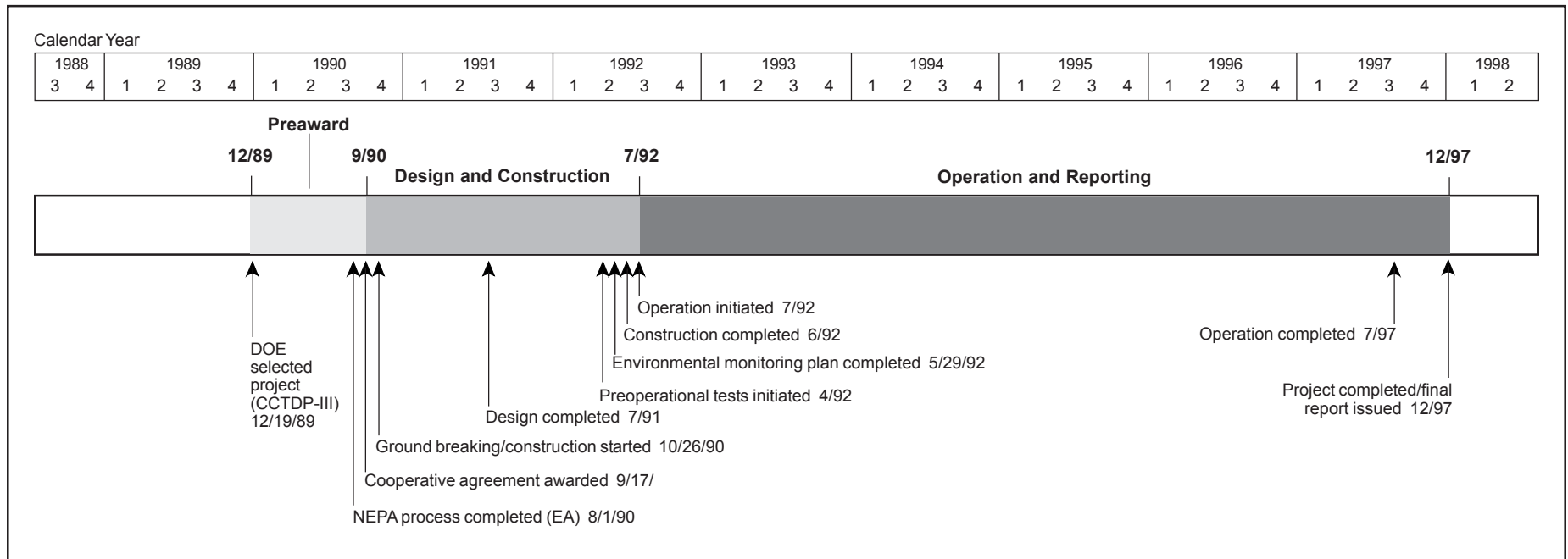

Results Summary

Environmental

- The PDF[®] contains 0.36% sulfur with a heat content of 11,100 Btu/lb (compared with 0.45% sulfur and 8,300 Btu/lb for the feed coal).
- The CDL[®] contains 0.6% sulfur and 140,000 Btu/gal (compared with 0.8% sulfur and 150,000 Btu/gal for No. 6 fuel oil).
- In utility applications, PDF[®] enabled reduction in SO₂ emissions, reduction in NO_x emissions (through flame stabilization), and maintenance of boiler rated capacity with fewer mills in service.
- LFC[®] products contained no toxins in concentrations anywhere close to federal limits.

Operational

- Steady-state operation exceeding 90% availability was achieved for extended periods for the entire plant (numerous runs exceeded 120 days duration).
- The LFC[®] process consistently produced 250 tons/day of PDF[®] and 250 barrels/day of CDL[®] from 500 tons/day of run-of-mine PRB coal.

- Integrated operation of the LFC[®] process components over five years has provided a comprehensive database for evaluation and design of a commercial unit.
- Over 83,500 tons of PDF[®] were shipped via 17 unit trains and one truck shipment to seven customers in six states. Shipments included 100% PDF[®] and blends from 14–94% PDF[®].
- PDF[®], alone and in blends, demonstrated excellent combustion characteristics in utility applications, providing heating values comparable to bituminous coal, more reactivity than bituminous coal, and a stable flame.
- The low-volatile PDF[®] also showed promise as a reductant in direct iron reducing testing and also as a blast furnace injectant in place of coke.
- Nearly 5 million gallons of CDL[®] were produced and shipped to eight customers in seven states.
- CDL[®] demonstrated fuel properties similar to a low-sulfur No. 6 fuel oil but with the added benefit of lower sulfur content. High aromatic hydrocarbon content, however, may make CDL[®] more valuable as a chemical feedstock.

Economic

- A commercial plant designed to process 15,000 metric tons per day would cost an estimated \$475 million (2001\$) to construct, with annual operating and maintenance costs of \$52 million per year.

Project Summary

Operational Performance

The LFC® facility operated for more than 15,000 hours over a five-year period. Steady-state operation was maintained for much of the demonstration with availabilities of 90% for extended periods. The length of operation and volume of production proved the soundness and durability of the process.

Exhibit 3-49 summarizes ENCOAL's production history. By the end of the demonstration, over 83,500 tons of PDF® were shipped via 17 unit trains and one truck shipment to seven customers in six states. Shipments included 100% PDF® and blends from 14–94% PDF®. Over 5 million gallons of CDL® were produced and shipped to eight customers in seven states.

As with most demonstrations, however, success required overcoming many challenges. The most difficult challenge was achieving stability of the PDF® product, which had to be resolved in order to achieve market acceptance.

In June 1993, efforts ceased in trying to correct persistent PDF® stability problems within the bounds of the original plant design. The rotary cooler failed to provide the deactivation necessary to quell spontaneous ignition of PDF®. ENCOAL concluded that a separate, sealed vessel was needed for product deactivation. A search for a suitable design led to adoption of a VFB. A 500-ton/day VFB was installed between the quench table and rotary cooler. (Plans were made for installation of a second 500 ton/day VFB but were never implemented.)

Although the VFB enhanced deactivation, the PDF still required “finishing” to achieve stabilization. Extensive study revealed that more oxygen was needed for deactivation. Two courses of action were pursued: (1) development of interim measures to finish deactivation external to the plant, enabling immediate PDF® shipment for test burns; and (2) development of an in-plant process for finishing, eliminating product quality and labor penalties for external finishing.

“Pile layering” was the primary external PDF® finishing measure adopted. However, PDF® quality becomes somewhat impaired due to changes in size, moisture, and ash content.

Pursuit of a finishing process step resulted in establishment of a stabilization task force composed of private sector and government engineers and scientists. The outcome was construction and testing of a Pilot Air Stabilization System (PASS) to complete the oxidative deactivation of PDF®. The PASS controls temperature and humidity during forced oxidation. The data obtained were used to develop specifications and design requirements for a full-scale, in-plant PDF® finishing unit based upon a commercial (Aeroglide) tower dryer design.

The first shipment of ENCOAL's liquid CDL® product experienced unloading problems. The use of heat tracing and tank heating coils solved the unloading problems for subsequent customers. The CDL® also contained more solids and water than had been hoped for, but was considered usable as a lower grade oil.

Following VFB installation, CDL® quality improved. The pour point ranged from 75–95 °F, and the flash point averaged 230 °F, both within the design range. Water content was down to 1–2%, and solids content was 2–4%. Improvements resulted from more consistent operation and lower pyrolysis temperatures and higher pyrolysis flow rates enabled by a new pyrolyzer water seal.

Environmental Performance

PDF® offers the advantages of low-sulfur Powder River Basin coal without a heating value penalty. In fact, the LFC® process removes organically bound sulfur, making the PDF® product lower in sulfur than the parent coal on a Btu basis. Because the ROM coal is low in ash, PDF® ash levels remain reasonable after processing, even though the ash level is essentially doubled (ash from one ton of ROM coal goes into one-half ton of PDF®).

Dust emissions were not a problem with PDF®. A dust suppressant (MK) was sprayed on the PDF® to coat the surface as it leaves the storage bin. Also, PDF® has a narrower particle size distribution than ROM coal, having a larger fines content but fewer particles in the fugitive dust range than ROM coal.

ENCOAL's test burn shipments became international when Japan's Electric Power Development Company (EPDC) evaluated six metric tons of PDF® in 1994. The EPDC, which must approve all fuels being considered for electric power generation in Japan, found PDF® acceptable for use in Japanese utility boilers.

In October 1996, instrumented combustion testing was conducted at the Indiana-Kentucky Electric Co-

**Exhibit 3-49
ENCOAL Production**

	Pre-VFB		Post-VFB				Total
	1992	1993	1994	1995	1996	1997 ¹	
Raw Coal Feed (tons)	5,200	12,400	67,500	65,800	68,000	39,340	258,240
PDF® Produced (tons)	2,200	4,900	31,700	28,600	33,300	19,300	120,000
PDF® Sold (tons)	0	0	23,700	19,100	32,700	7,400	82,900
CDL® Produced (bbl)	2,600	6,600	28,000	31,700	32,500	20,300	121,700
Hours on Line	314	980	4,300	3,400	3,600	2,603	15,197
Average Length of Runs (Days)	2	8	26	38	44	75	N/A

¹Through June 1997.

operative's (IKEC) Clifty Creek Station, Unit No. 3. Important findings included the following:

- Full generating capacity using PDF[®] was possible with one mill out of service, which was not possible using the baseline fuel. Operation using PDF[®] afforded time to perform mill maintenance and calibration without losing capacity or revenues, increasing capacity factor and availability, and decreasing operation and maintenance costs.
- NO_x emissions were reduced by 20% due to high PDF[®] reactivity, resulting in almost immediate ignition upon leaving the burner coal nozzle. Furthermore, PDF[®] sustained effective combustion (maintaining low loss on ignition) with very low excess oxygen, which is conducive to low NO_x emissions.
- PDF[®] use precipitated increased ash deposits in the convective pass that were wetter than those resulting from baseline coal use, requiring increased sootblowing to control build-up.

The CDL[®] liquid product is a low-sulfur, highly aromatic, heavy liquid hydrocarbon. CDL[®] fuel characteristics are similar to those of a low-sulfur No. 6 fuel oil, except that the sulfur content is significantly lower. CDL[®]'s market potential as a straight industrial residual fuel, however, appears limited. The market for CDL[®] as a fuel never materialized, and CDL[®] has limited application as a blend for high-sulfur residual fuels due to incompatibility of the aromatic CDL[®] with many straight-chain hydrocarbon distillates.

ENCOAL determined that a centrifuge was needed to reduce solids retention and improve marketability of CDL[®] (tests validated a 90% removal capability); and an optimum slate of upgraded products was identified. The upgraded products were: (1) crude cresylic acid, (2) pitch, (3) refinery feedstock (low-oxygen middle distillate), and (4) oxygenated middle distillate (industrial fuel).

Economic

The "base case" for economics of a commercial plant is the 15,000-metric-ton/day, three-unit North Rochelle LFC[®] plant, the commercial-scale plant proposed by ENCOAL, with an independent 80-MWe cogeneration

unit, and no synthetic fuel tax credit (29¢ tax credit). It is assumed that the cogeneration unit is owned and operated by an independent third party. The capital cost for a full-scale, three-module LFC[®] plant is \$475 million.

Economic benefits from an LFC[®] commercial plant are derived from the margin in value between a raw, unprocessed coal and the upgraded products, making an LFC[®] plant dependent on the cost of feed coal. In fact, this is the largest single operating cost item. The total estimated operating cost is \$9.00/ton of feed coal including the cost of feed coal, chemical supplies, maintenance, and labor.

Commercial Applications

In a commercial application, CDL[®] would be upgraded to cresylic acid, pitch, refinery feedstock, and oxygenated middle distillate. Oxygenated middle distillate, the lowest value by-product, would be used in lieu of natural gas as a make-up fuel for the process (30% of the process heat input). PDF[®] would be marketed not only as a boiler fuel but as a supplement to or substitute for coke in the steel industry. PDF[®] characteristics make it attractive to the metallurgical market as a coke supplement in pulverized-coal-injection and granular-coal-injection methods, and as a reductant in direct reduced iron processes.

Contacts

Douglas Archer, DOE/HQ, (301) 903-9443
douglas.archer@hq.doe.gov

Joseph B. Renk III, NETL, (304) 285-6406
joseph.renk@netl.doe.gov

References

ENCOAL[®] Mild Gasification Plant Commercial Plant Feasibility Study. U.S. Department of Energy. September 1997. Report No. DOE/MC/27339. (Available from NTIS as DE98002005.)

Final Design Modifications Report. U.S. Department of Energy. September 1997. Report No. DOE/MC/27339-5797. (Available from NTIS as DE98002006.)

ENCOAL[®] Mild Gasification Project: ENCOAL Project Final Report. Report No. DOE/MC/27339-5798. U.S. Department of Energy. September 1997. (Available from NTIS as DE98002007.)

"Results of the PDF[®] Test Burn at Clifty Creek Station." *Topical Report*. S.A. Johnson and B.A. Knottnerus. October 1996.

ENCOAL[®] Mild Coal Gasification Demonstration Project Public Design and Construction Report. Report No. DOE/MC/27339-4065. ENCOAL Corporation. December 1994. (Available from NTIS as DE95009711.)

ENCOAL[®] Mild Gasification Project—Project Performance Summary. Report No. DOE/FE-0409. U.S. Department of Energy. November 1999.

Industrial Applications

Blast Furnace Granular-Coal Injection System Demonstration Project

Project completed

Participant

Bethlehem Steel Corporation

Additional Team Members

British Steel Consultants Overseas Services, Inc.
(marketing arm of British Steel Corporation)—
technology owner

Clyde Pneumatic (formerly named Simon-Macawber,
Ltd.)—equipment supplier

Fluor Daniel, Inc.—architect and engineer

ATSI, Inc.—injection equipment engineer (North
America technology licensee)

Location

Burns Harbor, Porter County, IN (Bethlehem Steel's
Burns Harbor Plant, Blast Furnace Units C and D)

Technology

British Steel and Clyde Pneumatic blast furnace granular-coal injection (BFGCI) process

Plant Capacity/Production

7,000 net tons of hot metal (NTHM)/day requiring 2,800
tons/day of coal (each blast furnace)

Coal

Virginia Pocahontas/Buchanan; 0.76% S, 86.39% C
Oxbow; 0.76% S, 73.2% C

Project Funding

Total	\$194,301,790	100%
DOE	31,824,118	16
Participant	162,477,672	84

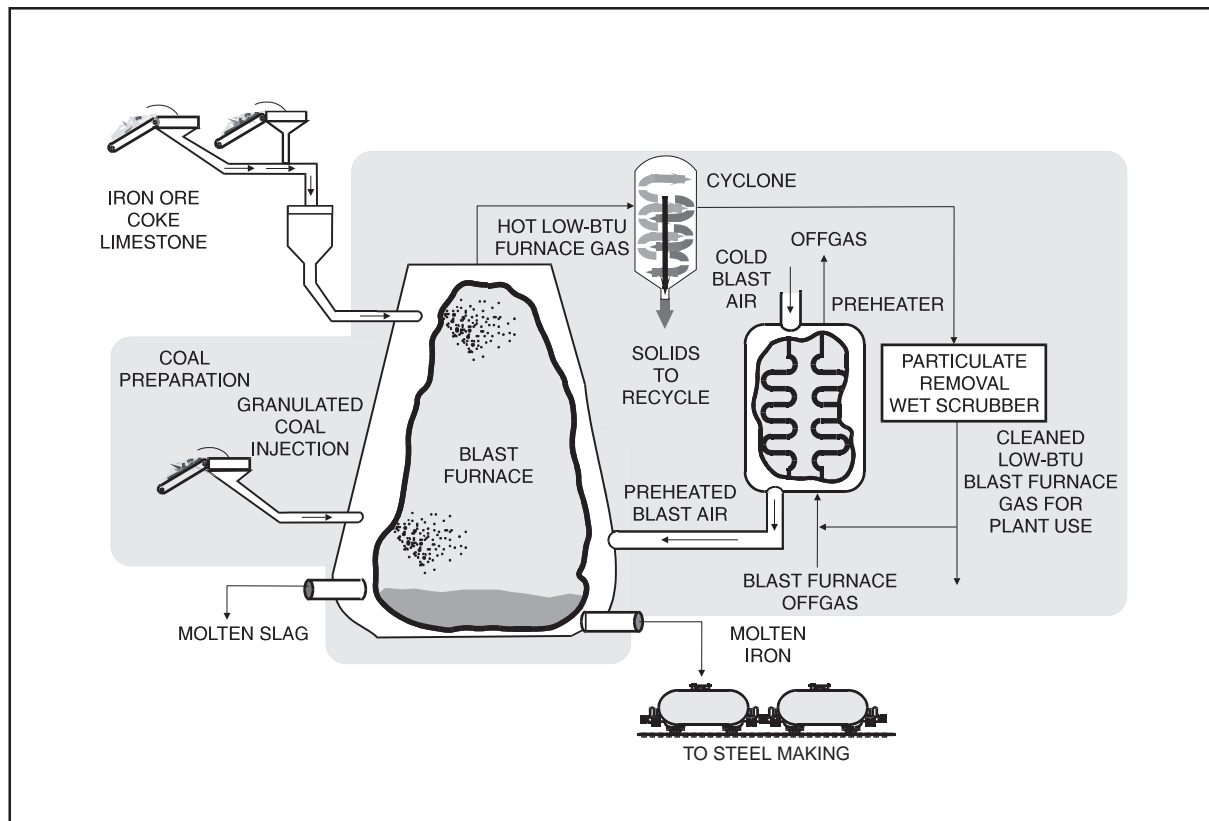

Project Objective

To demonstrate that granular coal could effectively displace coke and maintain established blast furnace production rates and quality specifications; to determine the effect of coal chemistry, such as ash content (quantity and sulfur levels) and volatile levels, on blast furnace performance; and to evaluate the economics of granular coal injection relative to natural gas injection.

Technology/Project Description

The BFGCI process uses granular coal, which requires significantly less grinding energy than pulverized coal to produce. The coal, along with heated air, is blown into the lower part of the blast furnace through passages called tuyeres, which create swept zones in the furnace called raceways. This preheated blast air provides partial oxidation of the coke introduced along with the iron ore and limestone at the top of the furnace. The coke serves as the

primary fuel and reducing agent for the process. The carbon reacts with the air and the iron oxide ore to produce heat, iron, and carbon monoxide. The limestone acts as a fluxing agent, creating a slag to capture mineral constituents such as sulfur and silicon not wanted in the product. The low-Btu gas leaving the furnace is essentially free of sulfur and is used to preheat blast air and fire a boiler for on-site power.

Bethlehem Steel introduced coal injection primarily to reduce the amount of coke needed in the blast furnace. Natural gas was normally injected into the tuyeres as a supplemental fuel. High levels of air toxics emissions result from coke production requiring extensive, expensive control systems. Bethlehem Steel retrofitted Units C and D at its Burns Harbor facility, both rated at 7,000 NTHM/day. The project sought to determine the effect of coal size and chemical composition on process performance and economics.

Project Summary

Bethlehem Steel retrofitted two high-capacity blast furnaces with BFGCI technology, Units C and D, at their Burns Harbor facility in a successful attempt to reduce coke use and become a self-sufficient supplier. The questions posed in applying the technology went to the effect of coal grind (size) and coal chemistry on coke displacement and furnace performance. A coal pulverizer was used to provide a range of coal grinds from granular (30% passing 200 mesh) to pulverized (80% passing 200 mesh). Each 7,000-NTHM/day furnace required approximately 2,800 tons/day of coal. Each BFGCI unit included a raw coal reclaim area and two 240-ton enclosed storage bins, a 500-Hp Williams variable speed coal-grinding mill and integrated dryer, two 180-ton product coal silos designed to exclude oxygen, two distribution bins each with 14 conical pant leg distributors, 28 injectors with lock hoppers and metered screw feeders, and a high-pressure air system transporting the coal 600 feet to injection lances mounted on 28 separate tuyeres.

Operational Performance

Initial steady-state testing involved operation on granulated (15% passing 200 mesh) Virginia Pocahontas low-ash, low-volatile, high-carbon coal in the Unit C furnace. This coal was selected as the baseline coal after a series of trials on different coal types. An average coal injection rate of 264 lb/NTHM was achieved over the baseline October 1996 performance period. The furnace coke rate during the period was 661 lb/NTHM, down from 740 lb/NTHM when operating on natural gas.

Increasing slag volume in the furnace controlled the additional sulfur and silicon loading from the coal injection to specified levels in the hot metal product. The slag also captured sufficient sulfur to prevent any additional sulfur in the furnace gas output. An adverse downturn in furnace permeability resulting from coal injection was moderately compensated for by increasing the oxygen enrichment from 24.4% to 27.3% and increasing steam input from 3.7 grains/scf to 19.8 grains/scf. The permeability adjustments enabled furnace productivity to be maintained.

To determine the coal/coke replacement ratio, all factors impacting on coke rate other than coal injection had to be

removed from the equation. After doing so, the adjusted furnace coke rate shows that one pound of Virginia Pocahontas baseline coal displaces 0.96 pounds of coke. The next test addressed the impact of ash volume on coke displacement and furnace performance. To do so, only the percentage of ash was increased, not the coal or ash chemistry. This was done by eliminating a coal cleaning step on the Pocahontas Seam coal (obtained from the Buchanan Mine), which increased the ash content from 5.3–7.7%. Tests showed that there is a coke rate disadvantage of 3 lb/NTHM for each one percentage point increase in coal ash content at an injection rate of 260 lb/NTHM; and the higher ash coal had no adverse impact on furnace permeability, productivity, or product quality.

Comparative testing followed to evaluate the effect of coal grind size (granular versus pulverized) on coke displacement and furnace performance as well as the effects of coal chemistry. Furnace D was used because of some temporary operating difficulties on Furnace C. A high-volatile, low-carbon Oxbow western coal was used in lieu of the baseline coal because of plugging problems experienced when pulverizing the baseline low-volatile coal and because there was the need to evaluate the impact of high-volatile coal on furnace performance. The Oxbow coal averaged 73.2% carbon and 11.2% ash versus 86.3% carbon and 5.3% ash for the baseline coal. The granular Oxbow coal grind was 15% passing 200 mesh and the pulverized Oxbow coal grind was 74% passing 200 mesh. Granular coal production required 60% less energy (19.6 kWh/ton) than pulverized coal production (31.4 kWh/ton). The grinding mill production rate for pulverizing the coal limited the coal injection rate to 183 lb/NTHM. After adjusting for the lower coal injection rate and other factors, it was determined that the coke rate when using the Oxbow coal was 46 lb/NTHM higher than when using the low-volatile baseline coal during tests—a substantial disadvantage. The blast furnace performance was unaffected by whether the coal was pulverized or granular at the coal injection rate of 183 lb/NTHM.

Environmental Performance

Data collected over each test period show that the use of injected coal in the blast furnace does not cause an increase in the sulfur content of the gas for coals averaging

0.76% sulfur. Evidence suggests that adjustments to slag volume and chemistry could effectively handle higher sulfur coals. However, the greatest environmental benefit derived from application of the BFGCI technology is the reduction in coke usage. Coke production is air toxics intensive and to be avoided if at all possible. With the application of the BFGCI technology, Bethlehem Steel can maintain steel production with the limited coke production currently on site.

Economic Summary

Capital cost for one complete injection system at Burns Harbor was approximately \$15 million (1990\$). This does not include infrastructure improvements, which cost \$87 million at Burns Harbor. The fixed operating cost, which includes labor and repair costs, was \$6.25/ton of coal. The variable operating cost, which includes water, electricity, natural gas, and nitrogen, was \$3.56/ton of coal. Coal costs were \$50–60/ton. This brought the total operating costs to \$59.81–69.81/ton of coal. Using \$60/ton of coal and a natural gas cost of \$2.80/10⁶ Btu, the cost savings would be about \$6.50/ton of iron produced. At Burns Harbor, which produces 5.2 million tons of iron per year, the annual savings would be about \$34 million and the payback period 3.44 years, using a simple rate of return calculation.

Commercial Applications

There are 35 operating blast furnaces in the United States. Seventeen of them are already using some type of coal injection. An extensive market analysis conducted by Bethlehem Steel showed that 18 of the 35 blast furnaces have the potential to utilize a BFGCI system. In August 1994, U.S. Steel Group contracted with ATSI and Clyde Pneumatic for the installation of a BFGCI unit at their Fairfield Works in Alabama, Blast Furnace #8. The unit, which began operating in 1995, is similar to Bethlehem's except that no added coal grinding facility was needed to meet the granular coal sizing requirements. Fairfield Works Blast Furnace #8 produces 6,300 NTHM/day. The BFGCI installation cost at Fairfield was \$20.2 million, with an additional \$5.5 million required to build a coal load-out facility.

Contacts

Douglas Archer, DOE/HQ, (301) 903-9443
douglas.archer@hq.doe.gov

Leo E. Makovsky, NETL, (412) 386-5814
leo.makovsky@netl.doe.gov

References

Blast Furnace Granular Coal Injection System, Final Report Volume 2—Project Performance and Economics. Bethlehem Steel Corporation. October 1999.

“Blast Furnace Granular-Coal Injection System Demonstration Project.” Hill, D.G. *et al.* *Sixth Clean Coal Conference Proceedings: Volume II—Technical Papers.* April–May, 1998.

Advanced Cyclone Combustor with Internal Sulfur, Nitrogen, and Ash Control

Project completed

Participant

Coal Tech Corporation

Additional Team Members

Commonwealth of Pennsylvania, Energy Development Authority—cofunder

Pennsylvania Power and Light Company—supplier of test coals

Tampella Power Corporation—host

Location

Williamsport, Lycoming County, PA (Tampella Power Corporation's boiler manufacturing plant)

Technology

Coal Tech's advanced, air-cooled, slagging combustor

Plant Capacity/Production

23 x 10⁶ Btu/hr of steam

Coal

Pennsylvania bituminous, 1.0–3.3% sulfur

Project Funding

Total	\$984,394	100%
DOE	490,149	50
Participant	494,245	50

Project Objective

To demonstrate that an advanced cyclone combustor can be retrofitted to an industrial boiler and that it can simultaneously remove up to 90% of the SO₂ and 90–95% of the ash within the combustor and reduce NO_x to 100 ppm.

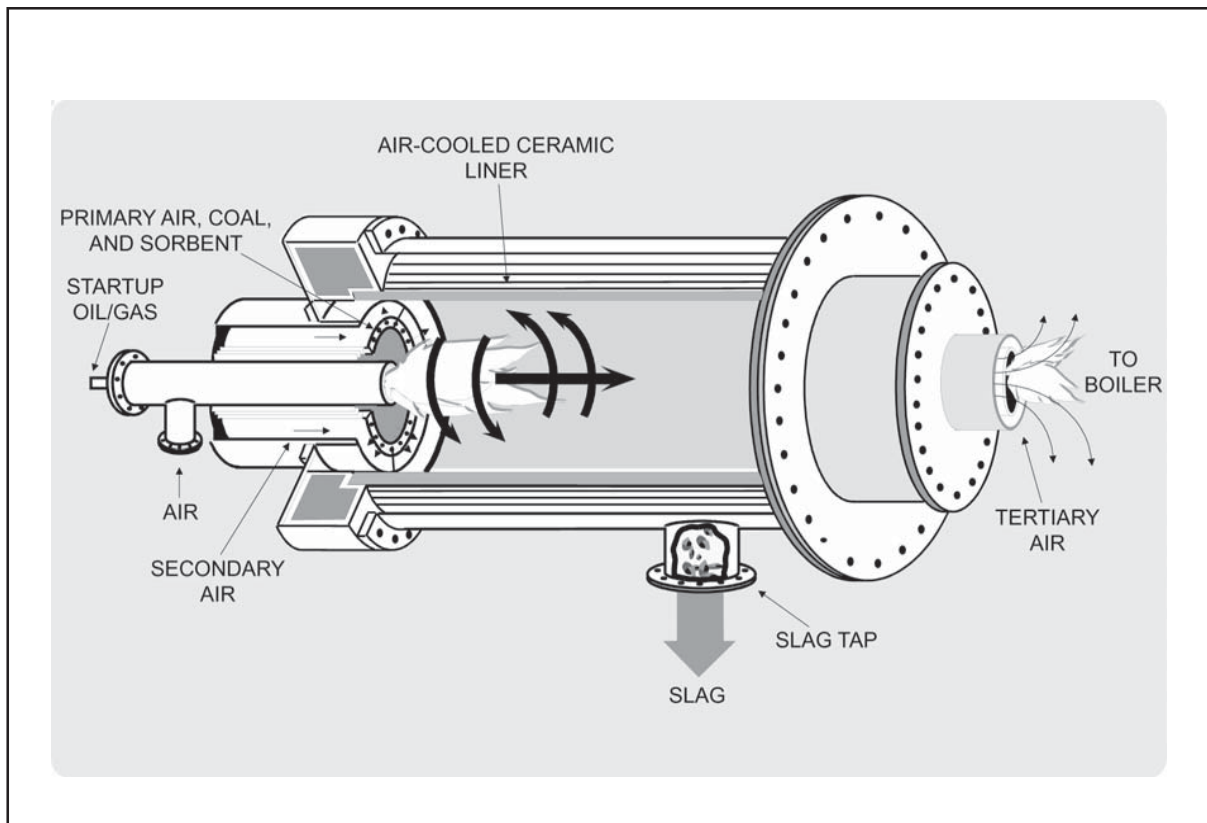

Technology/Project Description

Coal Tech's horizontal cyclone combustor is lined with an air-cooled ceramic. Pulverized coal, air, and sorbent are injected tangentially toward the wall through tubes in the annular region of the combustor to cause cyclonic action. In this manner, coal-particle combustion takes place in a swirling flame in a region favorable to particle retention in the combustor. Secondary air is used to adjust the overall combustor stoichiometry. Tertiary air is injected at the combustor/boiler interface. The ceramic liner is cooled by the secondary air and maintained at a temperature high enough to keep the slag in a liquid, free-flowing state. The secondary air is preheated by the combustor walls to attain efficient combustion of the coal particles in the fuel-rich combustor. Fine coal pulverization allows combustion of most of the coal particles near the cyclone wall. The combustor was designed so that a high percent-

age of the ash and sorbent fed to the combustor is retained as slag. For NO_x control, the combustor is operated fuel rich, with final combustion taking place in the boiler furnace to which the combustor is attached. The SO₂ is captured by injection of limestone into the combustor. The cyclonic action inside the combustor forces the coal ash and sorbent to the walls where it can be collected as liquid slag. Under optimal operating conditions, the slag contains a significant fraction of vitrified coal sulfur. Downstream sorbent injection into the boiler provides additional sulfur removal capacity.

In Coal Tech's demonstration, an advanced, air-cooled cyclone coal combustor was retrofitted to a 23 x 10⁶ Btu/hr, oil-fired package boiler located at the Tampella Power Corporation boiler factory in Williamsport, Pennsylvania.

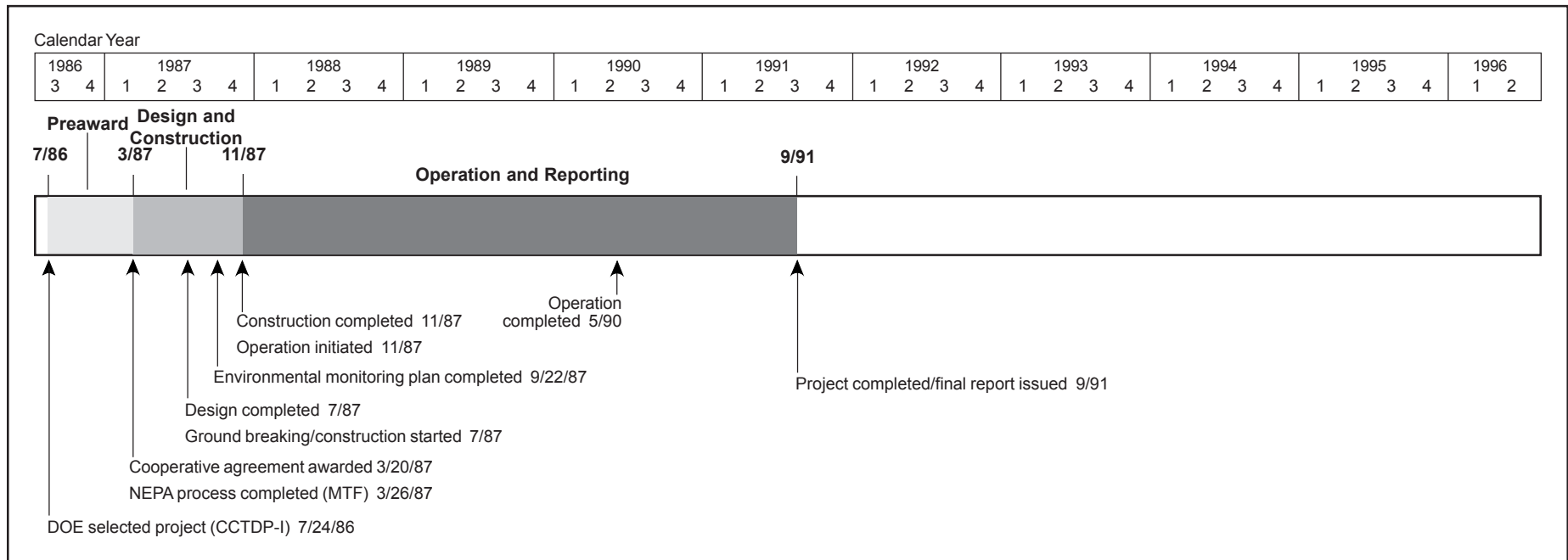

Results Summary

Environmental

- SO₂ removal efficiencies of over 80% were achieved with sorbent injection in the furnace at various calcium-to-sulfur (Ca/S) molar ratios.
- SO₂ removal efficiencies up to 58% were achieved with sorbent injection in the combustor at a Ca/S molar ratio of 2.0.
- A maximum of one-third of the coal's sulfur was retained in the dry ash removed from the combustor (as slag) and furnace hearth.
- At most, 11% of the coal's sulfur was retained in the slag rejected through the combustor's slag tap.
- NO_x emissions were reduced to 184 ppm by the combustor and furnace, and to 160 ppm with the addition of a wet particulate scrubber.
- Combustor slag was essentially inert.
- Ash/sorbent retention in the combustor as slag averaged 72% and ranged from 55–90%. Under more fuel-lean conditions, retention averaged 80%.

- Meeting local particulate emissions standards required the addition of a wet venturi scrubber.

Operational

- Combustion efficiencies of over 99% were achieved.
- A 3-to-1 combustor turndown capability was demonstrated. Protection of combustor refractory with slag was shown to be possible.
- A computer-controlled system for automatic combustor operation was developed and demonstrated.

Economic

- Because the technology failed to meet commercialization criteria, economics were not developed during the demonstration. However, subsequent efforts indicate that the incremental capital cost for installing the coal combustor in lieu of oil or gas systems is \$100–200/kW.

Project Summary

The novel features of Coal Tech's patented ceramic-lined, slagging cyclone combustor included its air-cooled walls and environmental control of NO_x , SO_2 , and solid waste emissions. Air cooling took place in a very compact combustor, which could be retrofitted to a wide range of industrial and utility boiler designs without disturbing the boiler's water-steam circuit. In this technology, NO_x reduction was achieved by staged combustion, and SO_2 was captured by injection of limestone into the combustor and/or boiler. Critical to combustor performance was removal of ash as slag, which would otherwise erode boiler tubes. This was particularly important in oil furnace retrofits where tube spacing is tight (made possible by the low-ash content of oil-based fuels).

The test effort consisted of 800 hours of operation, including five individual tests, each of four days duration. An additional 100 hours of testing was performed as part of a separate ash vitrification test. Test results obtained during operation of the combustor indicated that Coal Tech attained most of the objectives contained in the cooperative agreement. About eight different Pennsylvania bituminous coals with sulfur contents ranging from 1.0–3.3% and volatile matter contents ranging from 19–37% were tested.

Environmental Performance

A maximum of over 80% SO_2 reduction measured at the boiler outlet stack was achieved using sorbent injection in the furnace at various Ca/S molar ratios. A maximum SO_2 reduction of 58% was measured at the stack with limestone injection into the combustor at a Ca/S molar ratio of 2. A maximum of one-third of the coal's sulfur was retained in the dry ash removed from the combustor and furnace hearths, and as much as 11% of the coal's sulfur was retained in the slag rejected through the slag tap. Additional sulfur retention in the slag is possible by increasing the slag flow rate and further improving fuel-rich combustion and sorbent-gas mixing.



The Coal Tech combustor.

With fuel-rich operation of the combustor, a three-fourths reduction in measured boiler outlet stack NO_x was obtained, corresponding to 184 ppm. An additional reduction was obtained by the action of the wet particulate scrubber, resulting in atmospheric NO_x emissions as low as 160 ppm.

All the slag removed from the combustor produced trace metal leachates well below EPA's Drinking Water Standard. Total ash/sorbent retention as slag in the combustor, under efficient combustion operating conditions, averaged 72% and ranged from 55–90%. Under more fuel-lean conditions, the slag retention averaged 80%. After the CCT project, tests on fly ash vitrification in the combustor, modifications to the solids injection system, and increases in the slag flow rate produced substantial increases in the slag retention rate. To meet local stack particulate emission standards, a wet venturi particulate scrubber was installed at the boiler outlet.

Operational Performance

Combustion efficiencies exceeded 99% after proper operating procedures were achieved. Combustor turndown to 6×10^6 Btu/hr from a peak of 19×10^6 Btu/hr (or a 3-to-1 turndown) was achieved. The maximum heat input during the tests was around 20×10^6 Btu/hr, even though the combustor was designed for 30×10^6 Btu/hr and the boiler was thermally rated at around 25×10^6 Btu/hr. This

situation resulted from facility limits on water availability for the boiler. In fact, due to the lack of sufficient water cooling, even 20×10^6 Btu/hr was borderline, so that most of the testing was conducted at lower rates.

Different sections of the combustor had different materials requirements. Suitable materials for each section were identified. Also, the test effort showed that operational procedures were closely coupled with materials durability. As an example, by implementing certain procedures, such as changing the combustor wall temperature, it was possible to replenish the combustor refractory wall thickness with slag produced during combustion rather than by adding ceramic to the combustor walls.

The combustor's total operating time during the life of the CCT project was about 900 hours. This included approximately 100 hours of operation in two other fly ash vitrification test projects. Of the total time, about one-third was with coal; about 125 tons of coal were consumed.

Developing proper combustor operating procedures was also a project objective. Not only were procedures for operating an air-cooled combustor developed, but the entire operating database was incorporated into a computer-controlled system for automatic combustor operation.

Commercial Applications

The goal of this project was to validate the performance of the air-cooled combustor at a commercial scale. While the combustor was not yet fully ready for sale with commercial guarantees, it was believed to have commercial potential. Subsequent work was undertaken, which has brought the technology close to commercial introduction.

Contacts

Bert Zauderer, President, (610) 667-0442
Coal Tech Corporation
P.O. Box 154
Merion Station, PA 19066
bz.coaltech@verizon.net
(610) 677-0576 (fax)

William E. Fernald, DOE/HQ, (301) 903-9448
william.fernald@hq.doe.gov

Thomas A. Sarkus, (412) 386-5981
sarkus@netl.doe.gov

References

The Coal Tech Advanced Cyclone Combustor Demonstration Project—A DOE Assessment. Report No. DOE/PC/79799-T1. U.S. Department of Energy. May 1993. (Available from NTIS as DE93017043.)

The Demonstration of an Advanced Cyclone Coal Combustor; with Internal Sulfur, Nitrogen, and Ash Control for the Conversion of a 23-MMBtu/Hour Oil Fired Boiler to Pulverized Coal; Vol. 1: Final Technical Report; Vol. 2: Appendixes I-V; Vol. 3: Appendix VI. Coal Tech Corporation. August 1991. (Available from NTIS as DE92002587 and DE92002588.)

Comprehensive Report to Congress on the Clean Coal Technology Program: Advanced Cyclone Combustor with Internal Sulfur, Nitrogen, and Ash Control. Coal Tech Corporation. Report No. DOE/FE-0077. U.S. Department of Energy. February 1987. (Available from NTIS as DE87005804.)



Coal Tech's slagging combustor demonstrated the capability to retain, as slag, a high percentage of the non-fuel components injected into the combustor. The slag, shown on the conveyor, is essentially an inert, glassy by-product with value in the construction industry as an aggregate and in the manufacture of abrasives.

Cement Kiln Flue Gas Recovery Scrubber

Project completed

Participant

Passamaquoddy Tribe

Additional Team Members

Dragon Products Company—project manager and host

HPD, Incorporated—designer and fabricator of tanks and heat exchanger

Cianbro Corporation—constructor

Location

Thomaston, Knox County, ME (Dragon Products Company's coal-fired cement kiln)

Technology

Passamaquoddy Technology Recovery Scrubber™

Plant Capacity/Production

1,450 ton/day of cement; 250,000 scfm of kiln gas; and up to 274 ton/day of coal

Coal

Pennsylvania bituminous, 2.5–3.0% sulfur

Project Funding

Total	\$17,800,000	100%
DOE	5,982,592	34
Participant	11,817,408	66

Project Objective

To retrofit and demonstrate a full-scale industrial scrubber and waste recovery system for a coal-burning wet process cement kiln using waste dust as the reagent to accomplish 90–95% SO₂ reduction using high-sulfur eastern coals; and to produce commercial, potassium-based fertilizer by-products.

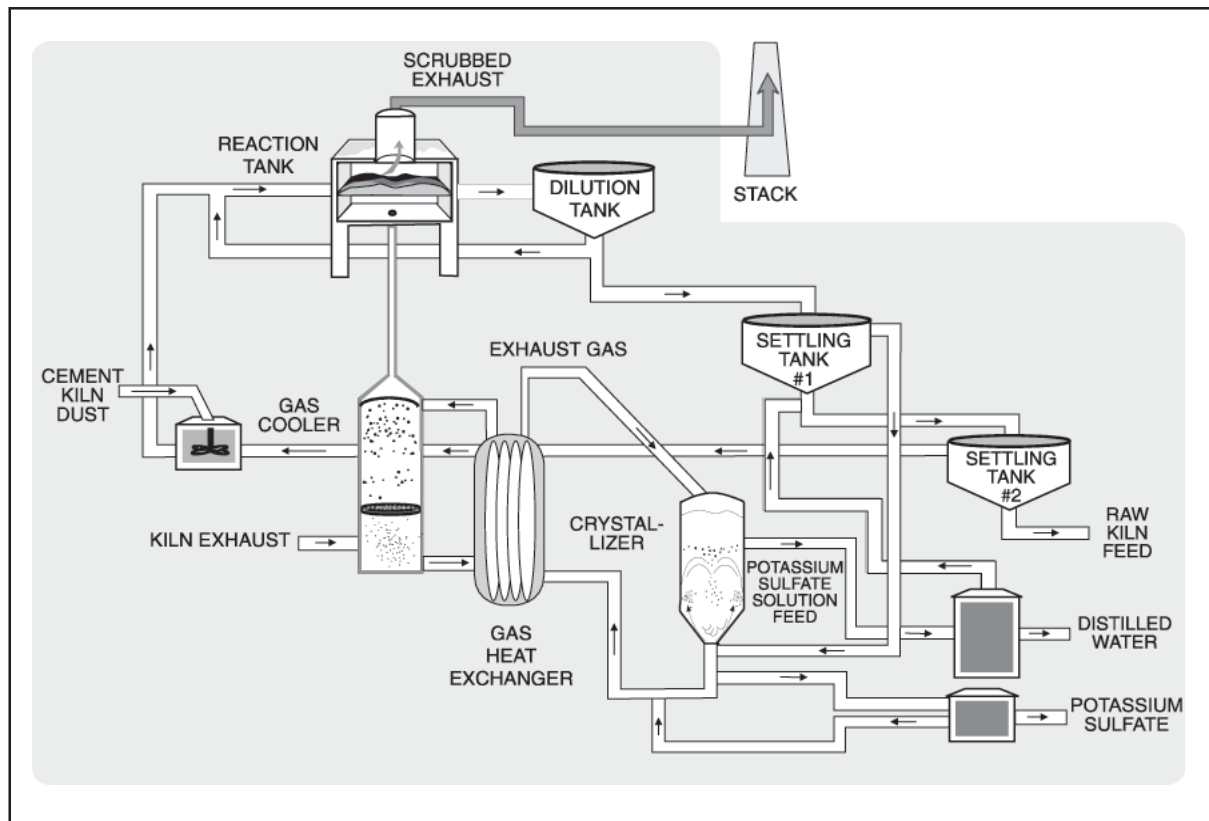

Technology/Project Description

The Passamaquoddy Technology Recovery Scrubber™ uses cement kiln dust (CKD), an alkaline-rich (potassium) waste, to react with the acidic flue gas. This CKD, representing about 10% of the cement feedstock otherwise lost as waste, is formed into a water-based slurry and mixed with the flue gas as the slurry passes over a perforated tray that enables the flue gas to percolate through the slurry. The SO₂ in the flue gas reacts with the potassium to form potassium sulfate, which stays in solution and remains in the liquid as the slurry undergoes separation into liquid and solid fractions. The solid fraction, in thickened slurry form and freed of the potassium and other alkali constituents, is returned to the kiln as feedstock (it is the alkali content that makes the CKD unusable as feedstock). No dewatering is necessary for the wet process used at the Dragon Products Company cement plant.

The liquid fraction is passed to a crystallizer that uses waste heat in the flue gas to evaporate the water and recover dissolved alkali metal salts. A recuperator lowers the incoming flue gas temperature to prevent slurry evaporation, enables the use of low-cost fiberglass construction material, and provides much of the process water through condensation of exhaust gas moisture.

The Passamaquoddy Technology Recovery Scrubber™ was constructed at the Dragon Products plant in Thomaston, Maine, a plant that can process approximately 450,000 ton/yr of cement. The process was developed by the Passamaquoddy Indian Tribe while it was seeking ways to solve landfill problems, which resulted from the need to dispose of CKD from the cement-making process.

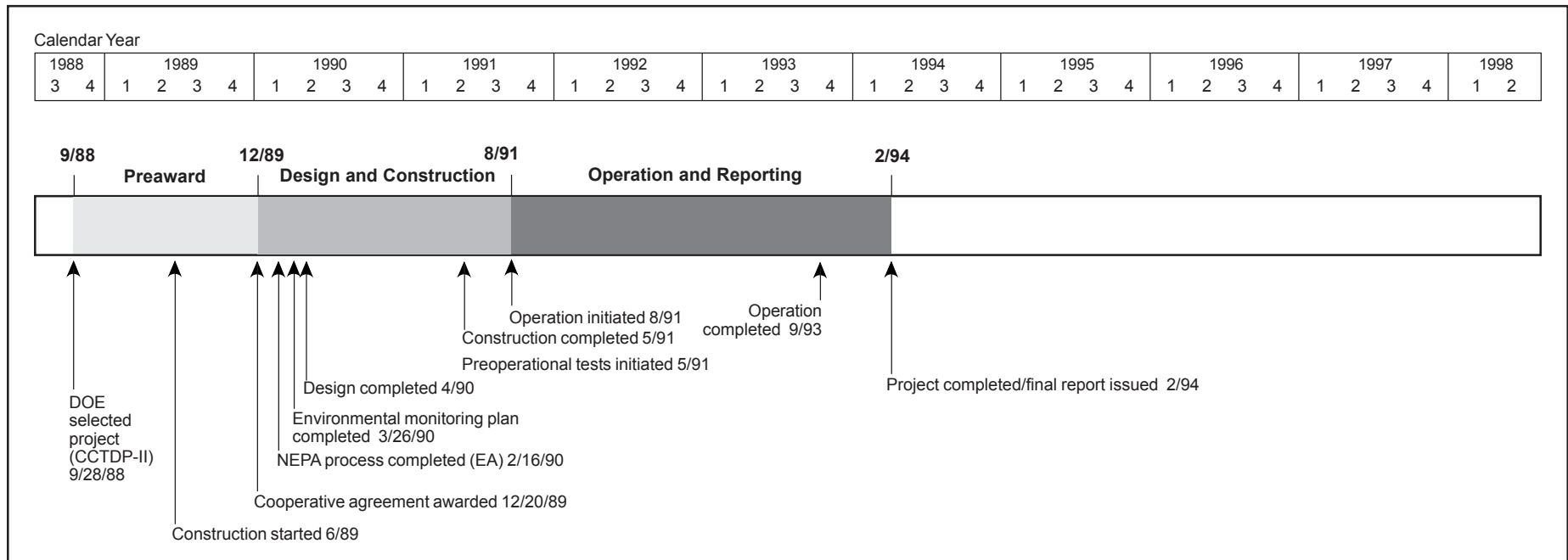

Results Summary

Environmental

- The SO₂ removal efficiency averaged 94.6% during the last several months of operation and 89.2% for the entire operating period.
- The NO_x removal efficiency averaged nearly 25% during the last several months of operation and 18.8% for the entire operating period.
- All of the 250 ton/day CKD waste produced by the plant was renovated and reused as feedstock, which resulted in reducing the raw feedstock requirement by 10% and eliminating solid waste disposal costs.
- Particulate emission rates of 0.005–0.007 gr/scf, about one-tenth that allowed for cement kilns, were achieved with dust loadings of approximately 0.04 gr/scf to the scrubber.
- Pilot testing conducted at U.S. Environmental Protection Agency laboratories under Passamaquoddy Technology, L.P. sponsorship showed 98% HCl removal.

- On three different runs, VOC (as represented by alpha-pinene) removal efficiencies of 72.3, 83.1, and 74.5% were achieved.
- A reduction of approximately 2% in CO₂ emissions was realized through recycling of the CKD.

Operational

- During the last operating interval, April to September 1993, recovery scrubber availability (discounting host site downtime) steadily increased from 65% in April 1993 to 99.5% in July 1993.

Economic

- Capital costs are approximately \$10,090,000 (1990\$) for a recovery scrubber to control emissions from a 450,000-ton/yr wet process plant, with a simple pay-back estimated in 3.1 years.
- Operation and maintenance costs, estimated at \$500,000/yr, plus capital and interest costs, are generally offset by avoided costs associated with fuel, feedstock, and waste disposal and with revenues from the sale of fertilizer.

Project Summary

The Passamaquoddy Technology Recovery Scrubber™ is a unique process that achieves efficient acid gas and particulate control through effective contact between flue gas and a potassium-rich slurry composed of waste kiln dust. Flue gas passes through the slurry as it moves over a special sieve tray. This results in high SO₂ and particulate capture, some NO_x reduction, and sufficient uptake of the potassium (an unwanted constituent in cement) to allow the slurry to be recycled as feedstock. Waste cement kiln dust, exhaust gases (including waste heat), and wastewater are the only inputs to the process. Renovated cement kiln dust, potassium-based fertilizer, scrubbed exhaust gas, and distilled water are the only proven outputs. There is no waste.

The scrubber was evaluated over three basic operating intervals dictated by winter shutdowns for maintenance and inventory and 14 separate operating periods (within these basic intervals) largely determined by unforeseen host-plant maintenance and repairs and a depressed cement market. Over the period August 1991 to September 1993, more than 5,300 hours were logged, 1,400 hours in the first operating interval, 1,300 hours in the second interval, and 2,600 hours in the third interval. Sulfur loadings varied significantly over the operating periods due to variations in feedstock and operating conditions.

Operational Performance

Several design problems were discovered and corrected during startup. No further problems were experienced in these areas during actual operation.

Two problems persisted into the demonstration period. The mesh-type mist eliminator, which was installed to prevent slurry entrainment in the flue gas, experienced plugging. Attempts to design a more efficient water spray for cleaning failed. However, replacement with a chevron-type mist eliminator prior to the third operating interval was effective. Potassium sulfate pelletization proved to be a more difficult problem. The cause was eventually isolated and found to be excessive water entrainment due to carry-over of gypsum and syngenite. Hydroclones were installed in the crystallizer circuit to separate the very fine gypsum and syngenite crystals from the much coarser

potassium sulfate crystals. Although the correction was made, it was not completed in time to realize pellet production during the demonstration period. After all modifications were completed, the recovery scrubber entered into the third and final operating interval—April to September 1993. During this interval, recovery scrubber availability (discounting host site downtime) steadily increased from 65% in April to 99.5% in July.

Environmental Performance

An average 250 ton/day of CKD waste generated by the Dragon Products plant was used as the sole reagent in the recovery scrubber to treat approximately 250,000 scfm of flue gas. All the CKD, or approximately 10 ton/hr, was renovated and returned to the plant as feedstock and mixed with about 90 ton/hr of fresh feed to make up the required

100 ton/hr. The alkali in the CKD was converted to potassium-based fertilizer, eliminating all solid waste. Exhibit 3-50 lists the number of hours per operating period, SO₂ and NO_x inlet and outlet readings in pounds per hour, and removal efficiency as a percentage for each operating period.

Average removal efficiencies during the demonstration period were 89.2% for SO₂ and 18.8% for NO_x emissions. No definitive explanation for the NO_x control mechanics was available at the conclusion of the demonstration.

Aside from the operating period emissions data, an assessment was made of inlet SO₂ load impact on removal efficiency. For SO₂ inlet loads in the range of 100 lb/hr or less, recovery scrubber removal efficiency averaged 82.0%. For SO₂ inlet loads in the range of 100–200 lb/hr,

Exhibit 3-50
Summary of Emissions and Removal Efficiencies

Operating Period	Operating Time (hr)	Inlet (lb/hr)		Outlet (lb/hr)		Removal Efficiency (%)	
		SO ₂	NO _x	SO ₂	NO _x	SO ₂	NO _x
1	211	73	320	10	279	87.0	12.8
2	476	71	284	11	260	84.6	08.6
3	464	87	292	13	251	85.4	14.0
4	259	131	252	16	165	87.6	34.5
5	304	245	293	28	243	88.7	17.1
6	379	222	265	28	208	87.4	21.3
7	328	281	345	28	244	90.1	29.3
8	301	124	278	10	188	91.8	32.4
9	314	47	240	7	194	85.7	19.0
10	402	41	244	6	218	86.1	10.5
11	460	36	315	6	267	83.4	15.0
12	549	57	333	2	291	95.9	12.4
13	464	86	288	4	223	95.0	22.6
14	405	124	274	9	199	92.4	27.4
Total operating time		5,316					
Weighted Average		109	289	12	234	89.2	18.8

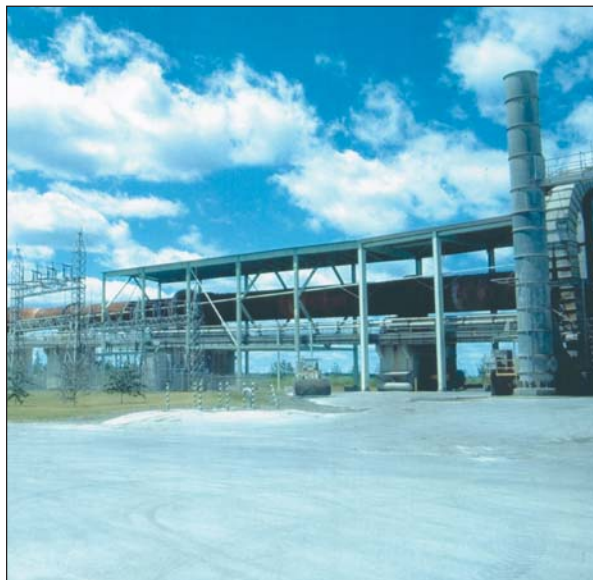

The Passamaquoddy Technology Recovery Scrubber™ was successfully demonstrated at Dragon Products Company's cement plant in Thomaston, Maine.

removal efficiency increased to 94.1% and up to 98.5% for loads greater than 200 lb/hr.

In compliance testing for Maine's Department of Environmental Quality, the recovery scrubber was subjected to dust loadings of approximately 0.04 gr/scf and demonstrated particulate emission rates of 0.005–0.007 gr/scf—less than one-tenth the current allowable limit.

Economic Performance

The estimated “as-built” capital cost to reconstruct the Dragon Products prototype, absent the modifications, is \$10,090,000 in 1990 dollars.

Annual operating and maintenance costs are estimated at \$500,000. Long-term annual maintenance costs are estimated at \$150,000. Power costs, estimated at \$350,000/yr, are the only significant operating costs. There are no costs for reagents or disposal, and no dedicated staffing or maintenance equipment is required.

The simple payback on the investment is projected in as little as 3.1 years considering various revenues and avoided costs that may be realized by installing a recovery

scrubber similar in size to the one used at Dragon Products. In making this projection, \$6,000,000 was added to the “as-built” capital costs to allow for contingency, design/permitting, construction interest, and licensing fees.

Commercial Applications

Of the approximately 2,000 Portland cement kilns in the world, about 250 are in the United States and Canada. These 250 kilns emit an estimated 230,000 ton/yr of SO₂ (only three plants have SO₂ controls, one of which is the Passamaquoddy Technology Recovery Scrubber™). The applicable market for SO₂ control is estimated at 75% of the 250 installations. If full penetration of this estimated market were realized, approximately 150,000 ton/yr of SO₂ reduction could be achieved.

The scrubber became a permanent part of the cement plant at the end of the demonstration. A feasibility study has been completed for a Taiwanese cement plant.

Contacts

Thomas N. Tureen, Project Manager, (207) 773-7166
Passamaquoddy Technology, L.P.
1 Monument Way, Suite 200
Portland, ME 04101
(207) 773-7166
(207) 773-8832 (fax)

William E. Fernald, DOE/HQ, (301) 903-9448
william.fernald@hq.doe.gov

John C. McDowell, NETL, (412) 386-6175
john.mcdowell@netl.doe.gov

References

Passamaquoddy Technology Recovery Scrubber™: Final Report. Volumes 1 and 2 (Appendices A–M. Passamaquoddy Tribe. February 1994. (Vol. 1 available from NTIS as DE94011175, Vol. 2 as DE94011176.)

Passamaquoddy Technology Recovery Scrubber™: Public Design Report. Report No. DOE/PC/89657-T2. Passamaquoddy Tribe. October 1993. (Available from NTIS as DE94008316.)

Passamaquoddy Technology Recovery Scrubber™: Topical Report. Report No. DOE/PC/89657-T1. Passamaquoddy Tribe. March 1992. (Available from NTIS as DE92019868.)

Comprehensive Report to Congress on the Clean Coal Technology Program: Cement Kiln Flue Gas Recovery Scrubber. Passamaquoddy Tribe. Report No. DOE/FE-0152. U.S. Department of Energy. November 1989. (Available from NTIS as DE90004462.)

Pulse Combustor Design Qualification Test

Project completed

Participant

ThermoChem, Inc.

Additional Team Member

Manufacturing and Technology Conversion International, Inc. (MTCI)—technology supplier

Location

Baltimore, MD (MTCI Test Facility)

Technology

MTCI's Pulsed Enhanced™ Steam Reforming process using a multiple resonance-tube pulse combustor.

Plant Capacity/Production

30 million Btu/hr (steam reformer)

Coal

Black Thunder (Powder River Basin) subbituminous

Project Funding

Total	\$8,612,054	100%
DOE	4,306,027	50
Participants	4,306,027	50

Project Objective

To demonstrate the operational/commercial viability of a single 253-resonance-tube pulse combustor unit and evaluate characteristics of coal-derived fuel gas generated by an existing Process Development Unit (PDU).

Technology/Project Description

MTCI's Pulsed Enhanced™ Steam Reforming process incorporates an indirect heating process for thermochemical steam gasification of coal to produce hydrogen-rich, clean, medium-Btu-content fuel gas without the need for an oxygen plant. Indirect heat transfer is provided by

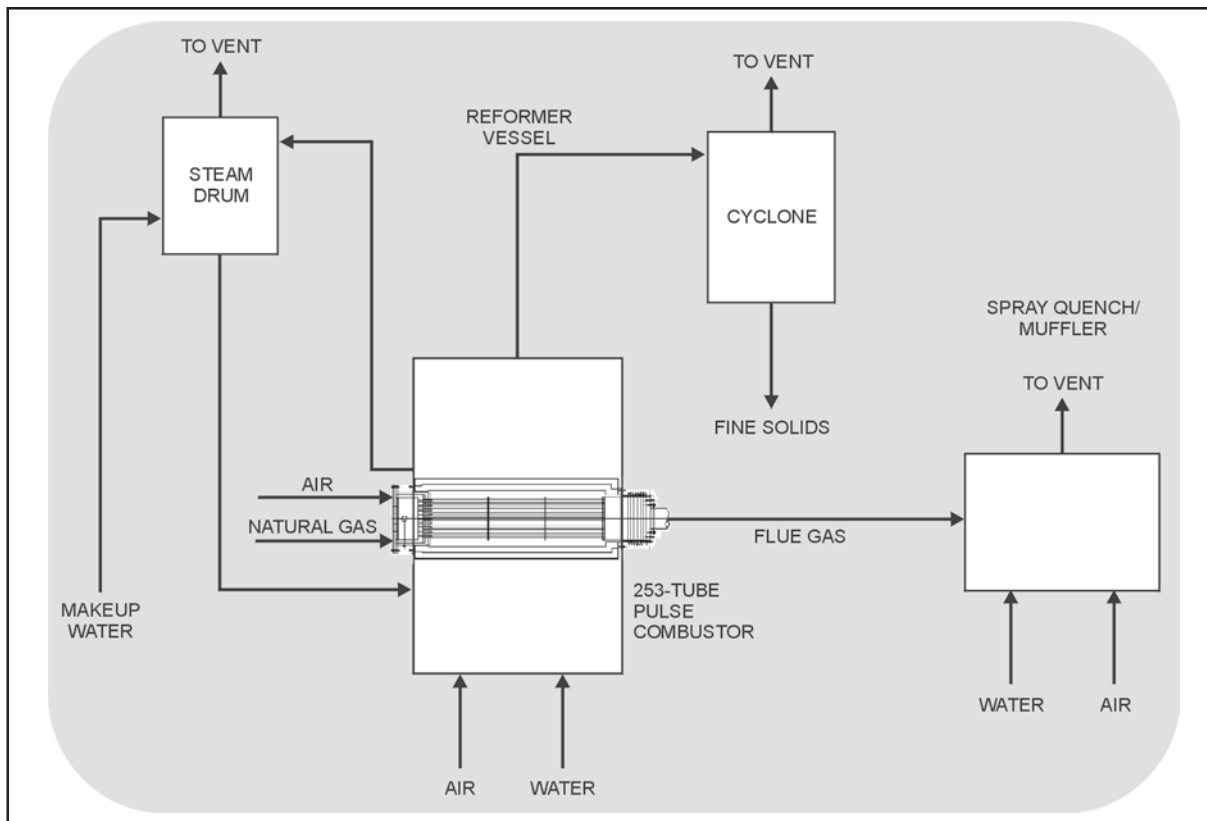

immersing a multiple resonance-tube pulse combustor in a fluidized-bed steam gasification reactor.

The combustor design qualification test facility consisted of a reformer vessel, pulse combustor, fuel train and burner management system, combustion air system, pulse combustor cooling water circuit, cyclone, and water injection system. The reformer was a one-inch thick carbon steel rectangular vessel. The pulse combustor consisted of a 253-tube bundle complete with refractory-lined combustion chamber, aerovalve plate assembly, inlet air plenum, and exhaust expansion bellows. The fuel train and burner management system consisted of a natural gas pressure reducing station, double block and bleed, modulating control valve, and orifice metering station. The combustion air system included forced draft fans, damper control, and flow measurement instrumentation. The pulse combustor cooling water circuit consisted of a

steam drum, recirculation pump, balancing valves, and feedwater makeup. The cyclone was a single-stage unit with drip leg isolation valve and catch drum. The water injection system consisted of eight injection nozzles, modulating control valve, and purge air system.

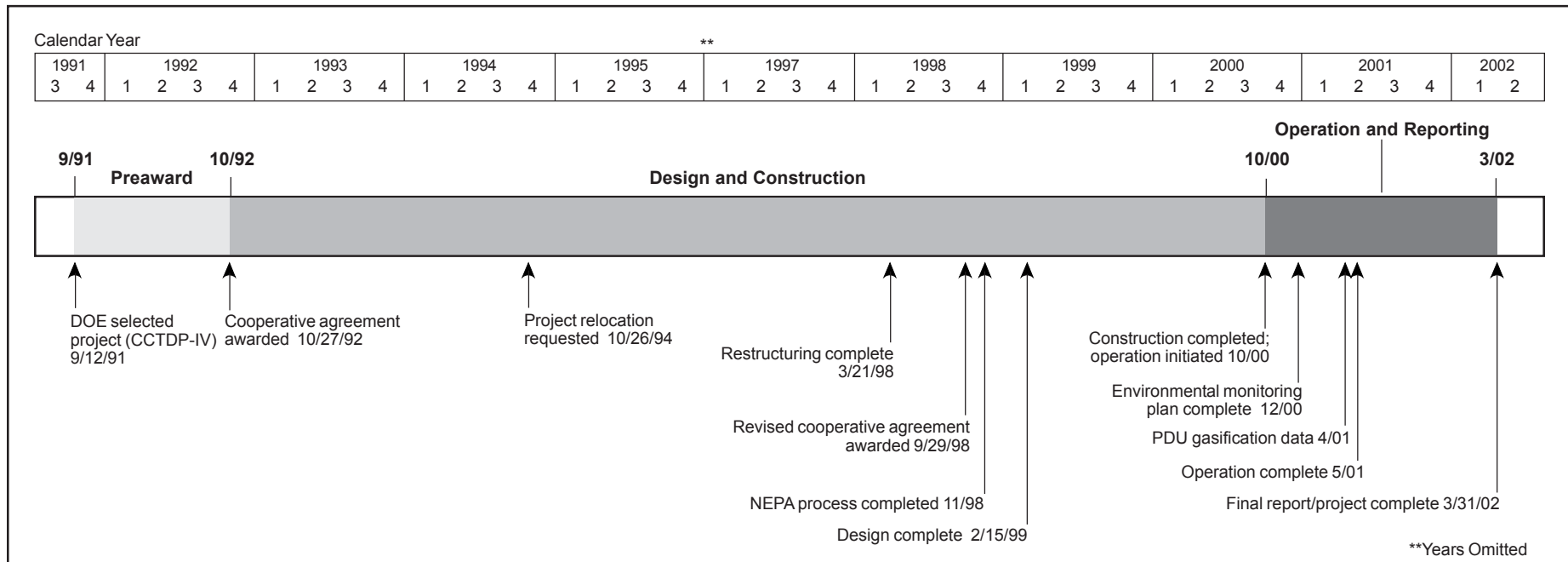

Results Summary

Environmental

- For the condensate from the coal characterization tests, the biological oxygen demand (BOD) was 13.98, 15.27, and 3.04 pounds per ton of dry coal for the 1,000 °F; 1,100 °F; and 1,200 °F tests, respectively.
- For the condensate from the coal characterization tests, volatile organic compounds (VOCs) were 593.7, 183.2, and 52.2 milligrams/kilogram (mg/kg) of dry feed for the 1,000 °F; 1,100 °F; and 1,200 °F tests, respectively.
- For the condensate from the coal characterization tests, semi-volatile organic compounds (SVOCs) were 1,868.3; 1,117.5; and 278.3 mg/kg of dry feed for the 1,000 °F; 1,100 °F; and 1,200 °F tests, respectively.

Operational

- The char product from the coal characterization tests was deemed acceptable for use in direct reduction of iron (DRI).
- The heat transfer rate for the pulse combustor tubes was 2.5 times higher than for conventional fire tubes.

- The sound pressure level varied from 165 dB (approximately 1.5 psi peak-to-peak pressure fluctuation) at about a 6×10^6 Btu/hr firing rate to about 173 dB (approximately 4 psi peak-to-peak pressure fluctuation) at about a 21×10^6 Btu/hr firing rate, although it may be possible to reduce these levels in a full-scale project.

Economic

- The total project installed cost for five 253-tube pulse combustors rated at 40 tons/hr to be used for char production is estimated at \$28,184,000, which includes \$8,095,170 for direct equipment and material costs, \$3,438,830 for direct installation and subcontract costs, \$6,100,000 for indirect costs, and \$10,500,000 for start-up, escalation, land, preliminary expenses, insurance, permits, warranties, licenses, and contingency.
- Fixed operating costs for char production were estimated at \$4,508,200 per year, and variable operating costs were estimated at \$8,696,600 per year, which includes a \$25/ton coal feedstock price. A by-product credit for the syngas was estimated at \$9,968,900 per year.

Project Summary

On September 10, 1998, DOE approved revision of ThermoChem, Inc.'s Cooperative Agreement for a scaled-down project. The original project, awarded in October 1992, was a commercial demonstration facility that would employ 10 identical 253-resonance-tube pulse combustor units. After fabrication of the first combustor unit, the project went through restructuring. The revised project demonstrated coal characterization tests on a single 2-tube pulse combustor operating on coal and combustor qualification tests on a single 253-tube pulse combustor operating on natural gas as a proxy for coal-derived synthesis gas (syngas). NEPA requirements were satisfied on November 30, 1998, with a Categorical Exclusion. ThermoChem initiated shakedown and commissioning tests in October 2000 and carried out emissions testing from December 2000 through May 2001.

Operational Performance

Pulse combustion involves the combustion-induced flow oscillations produced intentionally by the design of the equipment. The ThermoChem pulse combustor consists of an aerodynamic air inlet valve, a combustion chamber, and a resonance tube (tailpipe) as shown in Exhibit 3-51. The combustor configuration has no moving parts and is inherently reliable.

Operating as a fire tube boiler, ThermoChem claims that its pulse combustor increases heat transfer rates 3–5 times higher than conventional fire tubes used to heat fluidized-bed reactors. The increased heat transfer is probably due to flue gas oscillations resulting in a reduction in the boundary layer inside the tube. The data indicate that the heat transfer rate was 2.5 times higher than that in conventional fire tubes.

Coal Characterization Tests. For the 2-tube pulse combustor, tests were conducted on Black Thunder Powder River Basin coal supplied by Northside Mining. The choice of coal was based on the specific application of producing char for DRI.

The primary variable is an operating temperature that is the lowest possible temperature where satisfactory volatile matter and sulfur content in the char is achieved. The lowest possible operating temperature will result in the

lowest amount of fixed carbon converted to gas and the highest char yield.

The coal characterization tests were conducted in a PDU consisting of a steam reformer reactor and two-stage cyclone, coal metering and injection equipment, steam boiler and reverse osmosis unit, two stages of steam superheat, gas chromatography dry gas sampling and measurement, and instrumentation and controls. A schematic of the PDU is shown in Exhibit 3-52.

Three operating temperatures were evaluated for the coal characterization test—1,000 °F; 1,100 °F; and 1,200 °F. Despite some questions regarding the operating data collected, the resultant char was deemed suitable for DRI.

Pulse Combustor Qualification Test. Six series of tests were completed while firing the 253-tube pulse combustor. Data were obtained for both the up and down ramp of the pulse-combustor firing rate. Based on available data, the heat transfer coefficient inside the pulsed tube was about 2.5 times higher than for a non-pulsed tube.

The natural gas firing rate was ramped up to about 21×10^6 Btu/hr and held steady for about 10 hours. The pulse combustor operated well with strong pulsations and air suction with self-aspiration increasing significantly with firing rate. The dynamic pressure in the combustion chamber was monitored during the test through a Hewlett-Packard spectrum analyzer. The pulsation frequency was generally on the order of 58 Hz. The sound pressure level varied from 165 dB (approximately 1.5 psi peak-to-peak pressure fluctuation) at about a 6×10^6 Btu/hr firing rate to about 173 dB (approximately 4 psi peak-to-peak pressure fluctuation) at about a 21×10^6 Btu/hr firing rate. Due to self-aspiration, the demand on static pressure in the air plenum of the pulse combustor was rather low, less than 12 inches of water at a 21×10^6 Btu/hr firing rate. ThermoChem states that sound levels can be reduced to 85 dB at 3 feet by operating the combustors in a tandem arrangement at 180 degrees out of phase to cancel out noise emissions.

Environmental Performance

Coal Characterization Tests. For the 2-tube pulse combustor coal characterization tests, VOCs and SVOCs were collected and measured in the condensate. The total

VOCs were 593.7, 183.2, and 52.2 mg/kg of dry feed for the 1,000 °F; 1,100 °F; and 1,200 °F tests, respectively. The total SVOCs were 1,868.3; 1,117.5; and 278.3 mg/kg of dry feed for the 1,000 °F; 1,100 °F; and 1,200 °F tests, respectively.

A process condensate is the only waste stream generated in this process because the gas would be used as a fuel and the char is the primary product. Biological oxygen demand is the primary concern with the process condensate effluent. For the 1,000 °F; 1,100 °F; and 1,200 °F tests, the BOD was 13.98, 15.27, and 3.04 pounds per ton of dry coal, respectively. There is very little difference between the two lower operating temperatures as would be expected because there was little difference in char and gas yields for those two temperatures. However, at higher temperatures, gasification appears to begin and the organics that contribute to BOD are being somewhat destroyed.

Pulse Combustor Qualification Test. The composition of the flue gas from the combustor was monitored by a continuous emissions monitoring system. The oxygen (O_2) concentration was in the 4-10% range during stable firing of the combustor, corresponding to between 20% and 80% excess air. When there was no flue gas recycle, the O_2 concentration was relatively high. The high excess air operation was necessary to modulate combustion

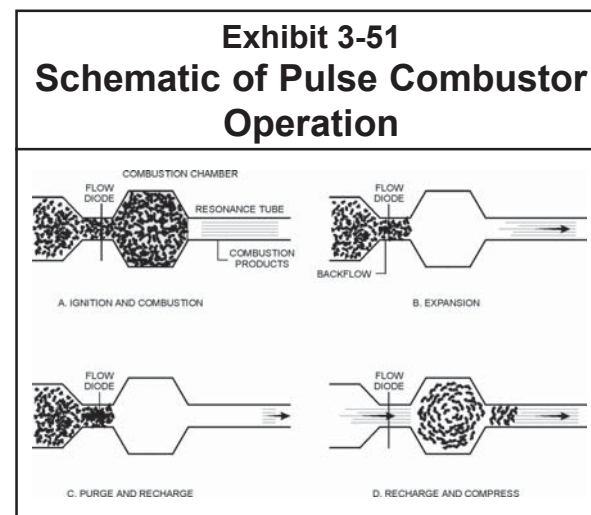
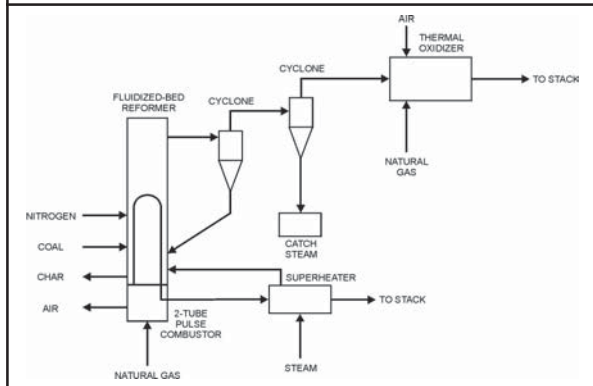

Exhibit 3-52 Schematic of ThermoChem's Process Development Unit



chamber temperature, and NO_x emissions were relatively high due to the high O_2 concentration. With flue gas recycle, the O_2 and NO_x levels were reduced significantly. NO_x concentrations were in the 10–30 parts per million by volume (ppmv) range.

Carbon monoxide (CO) concentration ranged from 100–400 ppmv during stable firing. Flow and temperature profiles had to be established and stabilized to achieve complete combustion. Total hydrocarbons (THC) emissions were generally low (<20 ppmv) except during transients, indicating high combustion efficiency. Carbon dioxide concentration ranged 7–10% during stable firing. With only two exceptions, combustion efficiency was in the range of 99.6–100%, independent of firing rate, excess air, or fluidized-bed temperature. The percent of the heat released that is transferred to the fluidized-bed and the water jacket as a function of firing rate. This percent remains relatively constant at a little over 50%, except at low firing rates (less than about 7×10^6 Btu/hr).

Economic Performance

A capital cost estimate was prepared based on a reactor with five 253-tube pulse combustors having a nominal coal processing (mild gasification) capacity of 40 tons/hr. The plant was assumed to be operating at 36 tons/hr (90%

onstream factor). The total project installed cost is estimated at \$28,184,000, which includes \$8,095,170 for direct equipment and material costs, \$3,438,830 for direct installation and subcontract costs, \$6,100,000 for indirect costs, and \$10,500,000 for start-up, escalation, land, preliminary expenses, insurance, permits, warranties, licenses, and contingency.

Fixed operating costs for char production were estimated at \$4,508,200 per year and variable operating costs were estimated at \$8,696,600 per year, which includes a \$25/ton coal feedstock price. A by-product credit for the syngas was estimated at \$9,968,900 per year. The resulting levelized cost of char would be \$88.67/ton (current 2002 dollars) and \$63.19/ton (constant 2002 dollars).

Commercial Applications

Pulsed Enhanced™ Steam Reforming has application in many different processes. Coal, with world production on the order of four billion tons per year, constitutes the largest potential feedstock for steam reforming. Other potential feedstocks include spent liquor from pulp and paper mills, refuse-derived fuel, municipal solid waste, sewage sludge, biomass, and other wastes.

Although the project demonstrated mild gasification of coal only, the technology has application to (1) black liquor processing and chemical recovery; (2) hazardous, low-level mixed waste volume reduction and destruction; (3) coal processing for production of hydrogen for fuel cell power generation and other uses, production of gas and char for the steel industry, and production of solid Clean Air Act compliance fuels, production of syngas for use as a fuel or as a feedstock for chemicals or high-quality liquid fuels production; (4) coal-pond waste and coal rejects processing for overfiring/reburning for utility NO_x control; and (5) utilization of a range of other fuels and wastes to produce a variety of value-added products. Application of the technology to the production of char for use in DRI has the potential for accomplishing significant reductions in pollutant emissions by reducing production of conventional metallurgical coke and facilitating the use of a new efficient iron-making process.

Project Contacts

Lee Rockvam, Project Manager
(410) 354-9890
(410) 354-9894 (fax)
lrockvam@tchem.net
ThermoChem, Inc.
6001 Chemical Road
Baltimore, MD 21226

William E. Fernald, DOE/HQ, (301) 903-9448
william.fernald@hq.doe.gov

Leo E. Makovsky, NETL, (412) 386-5814
leo.makovsky@netl.doe.gov

References

- Pulse Combustor Design Qualification Test: A DOE Assessment.* U.S. Department of Energy. 2003.
- Final Report Volume 2: Project Performance and Economics—Pulse Combustor Design Qualification Test and Clean Coal Feedstock Test.* ThermoChem, Inc. March 29, 2002.
- Final Report Volume 1: Public Design Report—Pulse Combustor Design Qualification Test and Clean Coal Feedstock Test.* ThermoChem, Inc. February 8, 2002.
- Comprehensive Report to Congress on the Clean Coal Technology Program: Demonstration of Pulse Combustion in an Application for Steam Gasification.* U.S. Department of Energy. October 1992.



ThermoChem's 253-tube pulse combustor.

Appendix A. Acronyms, Abbreviations, and Symbols

¢	cent	Ass'n.	Association	CCTDP-III	Third CCTDP solicitation
°C	degrees Celsius	ATCF	after tax cash flows	CCTDP-IV	Fourth CCTDP solicitation
°F	degrees Fahrenheit	atm	atmosphere(s)	CCTDP-V	Fifth CCTDP solicitation
\$	dollars (U.S.)	avg.	average	CCPI	Clean Coal Power Initiative
\$/kW	dollars per kilowatt	B&W	The Babcock & Wilcox Company	CCPI-I	First CCPI solicitation
\$/ton	dollars per ton	BFGCI	blast furnace granular-coal injection	CCPI-II	Second CCPI solicitation
%	percent	BG	British Gas	CCRI	China Coal Research Institute
®	registered trademark	Btu	British thermal unit(s)	CDL [®]	Coal-Derived Liquid [®]
™	trademark	Btu/kWh	British thermal units per kilowatt-hour	CD-ROM	Compact disk-read only memory
ABB CE	ABB Combustion Engineering, Inc.	BOD	biological oxygen demand	CEED	Center for Energy and Economic Development
ABB ES	ABB Environmental Systems	CAAA	Clean Air Act Amendments of 1990	CEM	continuous emissions monitor
ACCP	advanced coal conversion process	CaCO ₃	calcium carbonate (calcitic limestone)	CenPEEP	Center for Power Efficiency and Environmental Protection
ACFB	atmospheric circulating fluidized-bed	CAG	Coal Advisory Group	CEQ	Council on Environmental Quality
ADL	Arthur D. Little, Inc.	Ca/N	calcium-to-nitrogen	CFB	circulating fluidized-bed
A/E	architect/engineering	CaO	calcium oxide (lime)	CFD	Computational Fluid Dynamics
<i>AEO2002</i>	<i>Annual Energy Outlook 2002</i>	Ca(OH) ₂	calcium hydroxide (calcitic hydrated lime)	C/H	carbon-to-hydrogen
<i>AER2001</i>	<i>Annual Energy Review 2001</i>	Ca(OH) ₂ •MgO	dolomitic hydrated lime	CHP	combined heat and power
AFBC	atmospheric fluidized-bed combustion	CAPI	Clean Air Power Initiative	CKD	cement kiln dust
AFGD	advanced flue gas desulfurization	Ca/S	calcium-to-sulfur	CO	carbon monoxide
AIDEA	Alaska Industrial Development and Export Authority	CaSO ₃	calcium sulfite	CO ₂	carbon dioxide
AOFA	advanced overfire air	CaSO ₄	calcium sulfate	COP	Conference of Parties
APEC	Asia Pacific Economic Cooperation	CCOFA	close-coupled overfire air	CQE [™]	Coal Quality Expert [™]
APF	advanced particulate filter	CCT	clean coal technology	CQIM [™]	Coal Quality Impact Model [™]
ARIL	Advanced Retractable Injection Lances	CCTDP	Clean Coal Technology Demonstration Program	CSC	convective syngas cooler
ASFE	Assistant Secretary for Fossil Energy	CCTDP-I	First CCTDP solicitation	CSI	Clear Skies Initiative
ASME	American Society of Mechanical Engineers	CCTDP-II	Second CCTDP solicitation	CT-121	Chiyoda Thoroughbred-121
				CTI	Climate Technology Initiative

CUB	coal utilization by-product(s)	EPRI	Electric Power Research Institute	gr	grains
CURC	Coal Utilization Research Council	ESP	electrostatic precipitator	GR	gas reburning
CX	categorical exclusion	EU	European Union	GRI	Gas Research Institute
CZD	confined zone dispersion	EWG	exempt wholesale generator	GR-LNB	gas reburning and low-NO _x burner
dB	decibels	ext.	extension	GR-SI	gas reburning and sorbent injection
DER	discrete emissions reduction	FBC	fluidized-bed combustion	GSA	gas suspension absorption
DME	dimethyl ether	FCCC	Framework Convention on Climate Change	GVEA	Golden Valley Electric Association
DOE	U.S. Department of Energy	FE	Office of Fossil Energy	GW	gigawatt(s)
DOE/HQ	U.S. Department of Energy Headquarters	FeO	iron oxide	GWe	gigawatt(s)-electric
DRI	direct reduction of iron	Fe ₂ S	pyritic sulfur	H	elemental hydrogen
DSE	dust stabilization enhancement	FERC	Federal Energy Regulatory Commission	H ₂	molecular hydrogen
DSI	dry sorbent injection	FETC	Federal Energy Technology Center (now NETL)	H ₂ S	hydrogen sulfide
EA	environmental assessment	FGD	flue gas desulfurization	H ₂ SO ₄	sulfuric acid
EE	Eastern Europe	FLGR	flue gas recirculation	HAPs	hazardous air pollutants
EE/FSU	Eastern Europe/Former Soviet Union	FLGR/SNCR	flue gas recirculation/selective noncatalytic reduction	HCl	hydrogen chloride
EEI	Edison Electric Institute	FONSI	finding of no significant impact	HF	hydrogen fluoride
EER	Energy and Environmental Research Corporation	FRP	fiberglass-reinforced plastic	Hg	mercury
EERC	Energy and Environmental Research Center, University of North Dakota	FSU	Former Soviet Union	HGPFS	hot gas particulate filter system
EETC	Energy and Environmental Technology Center	ft, ft ² , ft ³	foot (feet), square feet, cubic feet	HHV	higher heating value
EFCC	externally fired combined-cycle	FY	fiscal year	hr.	hour(s)
EIA	U.S. Energy Information Administration	gal	gallon(s)	HRSG	heat recovery steam generator
EIS	environmental impact statement	gal/ft ³	gallons per cubic foot	ICCR	International Committee on Coal Research
EIV	Environmental Information Volume	GB	gigabyte(s)	ICR	information collection request
EMP	environmental monitoring plan	GDP	gross domestic product	ID	Induced Draft
EPA	U.S. Environmental Protection Agency	GE	General Electric	IEA	International Energy Agency
EPAct	Energy Policy Act of 1992	GEP	Greenhouse Gas Pollution Prevention	IEAT	Industrial Estates Authority of Thailand
EPCRA	Emergency Planning and Community Right-To-Know Act	GHG	greenhouse gases	<i>IEO2003</i>	<i>International Energy Outlook 2003</i>
EPDC	Japan's Electric Power Development Company	GNOCIS	Generic NO _x Control Intelligent System	IGCC	integrated gasification combined-cycle
		GPC	Gilberton Power Company	IGFC	integrated gasification fuel cell
		gpm	gallons per minute	in, in ² , in ³	inch(es), square inch(es), cubic inch(es)
				JBR	Jet Bubbling Reactor®

KCl	potassium chloride	MTBE	methy tertiary butyl ether	NSR	New Source Review
K ₂ SO ₄	potassium sulfate	MTCI	Manufacturing and Technology Conversion International	NSR	normalized stoichiometric ratio
kW	kilowatt(s)	MTF	memorandum (memoranda)-to-file	NTHM	net tons of hot metal
kWh	kilowatt-hour(s)	MW	megawatt(s)	NTIS	National Technical Information Service
LAC	Latin America and the Caribbean	MWe	megawatt(s)-electric	NTPC	National Thermal Power Corporation
lb	pound(s)	MWt	megawatt(s)-thermal	NYSEG	New York State Electric & Gas Corporation
L/G	liquid-to-gas	N	elemental nitrogen	O	elemental oxygen
LHV	lower heating value	N ₂	molecular nitrogen	O ₂	molecular oxygen
LIMB	limestone injection multistage burner	n.d.	not dated	O ₃	ozone
LNB	low-NO _x burner	N/A	not applicable	O&M	operation and maintenance
LNCB [®]	low-NO _x cell burner	NAAQS	National Ambient Air Quality Standards	OC&PS	Office of Coal & Power Systems
LNCFS	Low-NO _x Concentric-Firing System	Na/Ca	sodium-to-calcium	OECD	Organisation for Economic Co-operation and Development
LNG	liquefied natural gas	Na ₂ S	sodium-to-sulfur	OSTI	Office of Scientific and Technical Information
LOI	loss-on-ignition	NaHCO ₃	sodium bicarbonate	OTAG	Ozone Transport Assessment Group
LPMEOH [™]	Liquid phase methanol	NaOH	sodium hydroxide	OTC	Ozone Transport Commission
LRCWF	low-rank coal-water-fuel	Na ₂ CO ₃	sodium carbonate	PASS	Pilot Air Stabilization System
LSDE	Laboratorium Sumderdaya Energi	NARSTO	North American Research Strategy for Tropospheric Ozone	PC	personal computer
LSFO	limestone forced oxidation	NEDO	New Energy Development Organization	PCAST	Presidential Committee of Advisors on Science and Technology
MACT	maximum achievable control technology	NEP	National Energy Policy	PCFB	pressurized circulating fluidized-bed
MASB	multi-annular swirl burner	NEPA	National Environmental Policy Act	PDF [®]	Process-Derived Fuel [®]
MB	megabyte(s)	NETL	National Energy Technology Laboratory (formerly FETC)	PEIA	programmatic environmental impact assessment
MCFC	molten carbonate fuel cell	NGCC	natural gas combined cycle	PEIS	programmatic environmental impact statement
MCR	Maximum Continuous Rating	NH ₃	ammonia	PEOA [™]	Plant Emission Optimization Advisor [™]
MDEA	methyldiethanolamine	Nm ³	normal cubic meter	PENELEC	Pennsylvania Electric Company
MgCO ₃	magnesium carbonate	NMA	National Mining Association	PEP	progress evaluation plan
MgO	magnesium oxide	NO ₂	nitrogen dioxide	PFBC	pressurized fluidized-bed combustion
MHz	megahertz	NOPR	Notice of Proposed Rulemaking	PJBH	pulse jet baghouse
mills/kWh	mills per kilowatt hour	NO _x	nitrogen oxides		
min	minute(s)	NRC	National Research Council		
mo	month(s)	NSPS	New Source Performance Standards		
MOST	Ministry of Science and Technology				
MPF	multiphase flow				
MSW	municipal solid waste				

PM	particulate matter	SAP	sulfuric acid plant	UARG	Utility Air Regulatory Group
PM ₁₀	particulate matter less than 10 microns in diameter	SBIR	Small Business Innovation Research	UBC	unburned carbon
PM _{2.5}	particulate matter less than 2.5 microns in diameter	SCADA	supervisory control and data acquisition	UBCL	unburned carbon losses
PON	program opportunity notice	scf	standard cubic feet	U.K.	United Kingdom
PPA	Pollution Prevention Act	scfm	standard cubic feet per minute	UNDEERC	University of North Dakota's Energy and Environmental Research Center
PPII	Power Plant Improvement Initiative	SCR	selective catalytic reduction	UNESCO	United Nations Educational, Scientific and Cultural Organization
PRB	Powder River Basin	SCS	Southern Company Services, Inc.	URL	Uniform Resource Locator
ppm	parts per million (mass)	SDA	spray dryer absorber	U.S.	United States
ppmv	parts per million by volume	SER	Schuylkill Energy Resources	USAID	U.S. Agency for International Development
PRC	People's Republic of China	SFC	Synthetic Fuels Corporation	VFB	vibrating fluidized bed
PSCC	Public Service Company of Colorado	S-H-U	Saarberg-Hölter-Umwelttechnik	V-I	voltage current product
PSD	Prevention of Significant Deterioration	SI	sorbent injection	VOC	volatile organic compound
PSDF	Power Systems Development Facility	SIP	State Implementation Plan	w.c.	water column
psi	pound(s) per square inch	SM	service mark	WDNR	Wisconsin Department of Natural Resources
psia	pound(s) per square inch absolute	SNCR	selective noncatalytic reduction	WES	wastewater evaporation system
psig	pound(s) per square inch gauge	SNRB™	SO _x -NO _x -Rox Box™	w.g.	water gage
PUHCA	Public Utility Holding Company Act of 1935	SO ₂	sulfur dioxide	WLFO	wet limestone, forced oxidation
PURPA	Public Utility Regulatory Policies Act of 1978	SO ₃	sulfur trioxide	WMPI	Waste Management Processors, Inc.
QF	qualifying facility	SOFA	separated overfire air	WPPF	Working Party on Fossil Fuels
RAM	random access memory	SOFC	solid oxide fuel cell	wt.	weight
R&D	research and development	SOW	statement of work	yr.	year(s)
RD&D	research, development, and demonstration	SPG	Shangdong Power Group	ZPEG	Zhejiang Provincial Energy Group
RDF	refuse derived fuel	SPPC	Sierra Pacific Power Company		
REA	Rural Electrification Administration	std ft ³	standard cubic feet		
ROD	Record of Decision	STTR	Small Business Technology Transfer Program		
ROM	run-of-mine	SVGA	super video graphics adapter		
RP&L	Richmond Power & Light	SVOC	semi-volatile organic compounds		
rpm	revolutions per minute	TAG™	Technical Assessment Guide™		
RUS	Rural Utility Service	TCLP	toxicity characteristics leaching procedure		
S	sulfur	TRI	Toxics Release Inventory	AK	Alaska
		TVA	Tennessee Valley Authority	AL	Alabama
		UAF	University of Alaska, Fairbanks	AR	Arkansas
				AZ	Arizona

State Abbreviations

AK	Alaska
AL	Alabama
AR	Arkansas
AZ	Arizona

CA	California	PA	Pennsylvania
CO	Colorado	PR	Puerto Rico
CT	Connecticut	RI	Rhode Island
DC	District of Columbia	SC	South Carolina
DE	Delaware	SD	South Dakota
FL	Florida	TN	Tennessee
GA	Georgia	TX	Texas
HI	Hawaii	UT	Utah
IA	Iowa	VA	Virginia
ID	Idaho	VI	Virgin Islands
IL	Illinois	VT	Vermont
IN	Indiana	WA	Washington
KS	Kansas	WI	Wisconsin
KY	Kentucky	WV	West Virginia
LA	Louisiana	WY	Wyoming
MA	Massachusetts		
MD	Maryland		
ME	Maine		
MI	Michigan		
MN	Minnesota		
MO	Missouri		
MS	Mississippi		
MT	Montana		
NC	North Carolina		
ND	North Dakota		
NE	Nebraska		
NH	New Hampshire		
NJ	New Jersey		
NM	New Mexico		
NV	Nevada		
NY	New York		
OH	Ohio		
OK	Oklahoma		
OR	Oregon		

Other

Some companies have adopted an acronym as their corporate names. The following corporate names reflect the former name of the company.

BG/L	British Gas Lurgi
JEA	Jacksonville Electric Authority
KRW	Kellogg Rust Westinghouse

Index of Projects and Participants

Symbols

- 10-MWe Demonstration of Gas Suspension Absorption 3-2, 3-6, 3-8, 3-12
- 180-MWe Demonstration of Advanced Tangentially Fired Combustion Techniques for the Reduction of NO_x Emissions from Coal-Fired Boilers 3-2, 3-6, 3-9, 3-58

A

- ABB Combustion Engineering, Inc. 3-7, 3-8, 3-124
- ABB Environmental Systems 3-6, 3-8, 3-64
- Achieving NSPS Emission Standards Through Integration of Low-NO_x Burners with an Optimization Plan for Boiler Combustion 2-3, 2-4, 2-8
- Advanced Coal Conversion Process Demonstration 2-3, 2-4, 2-38
- Advanced Cyclone Combustor with Internal Sulfur, Nitrogen, and Ash Control 3-4, 3-7, 3-8, 3-138
- Advanced Flue Gas Desulfurization Demonstration Project 3-2, 3-6, 3-8, 3-24
- Advanced Multi-Product Coal Utilization By-Product Processing Plant 2-3, 2-4, 2-48
- Air Products Liquid Phase Conversion Company, L.P. 3-7, 3-8, 3-120
- AirPol, Inc. 3-6, 3-8, 3-12
- Alaska Industrial Development and Export Authority 3-7, 3-8, 3-114
- Arthur D. Little, Inc. 2-10, 2-30

B

- Babcock & Wilcox Company, The 3-6, 3-8, 3-38, 3-42, 3-68, 3-72
- Bechtel Corporation 3-6, 3-8, 3-16
- Bethlehem Steel Corporation 3-7, 3-8, 3-134
- Big Bend Power Station Neural Network-Sootblower Optimization 2-3, 2-4, 2-16

- Blast Furnace Granular-Coal Injection System Demonstration Project 3-4, 3-7, 3-8, 3-134

C

- Cement Kiln Flue Gas Recovery Scrubber 3-4, 3-7, 3-8, 3-142
- Clean Coal Diesel Demonstration Project 2-3, 2-4, 2-30
- Clean Power from Integrated Coal/Ore Reduction (CPICOR™) 2-3, 2-4, 2-44
- Coal Tech Corporation 3-7, 3-8, 3-138
- Colorado Springs Utilities 2-3, 2-26
- Commercial Demonstration of the Manufactured Aggregate Processing Technology Utilizing Spray Dryer Ash 2-3, 2-4, 2-46
- Commercial-Scale Demonstration of the Liquid Phase Methanol (LPMEOH™) 3-4, 3-7, 3-8, 3-120
- Confined Zone Dispersion Flue Gas Desulfurization Demonstration 3-2, 3-6, 3-8, 3-16
- CONSOL Energy, Inc. 2-3, 2-4, 2-12
- CPICOR™ Management Company LLC 2-3, 2-4, 2-44
- CQ Inc. 3-7, 3-8, 3-124

D

- Demonstration of a Full-Scale Retrofit of the Advanced Hybrid Particulate Collector Technology 2-3, 2-4, 2-14
- Demonstration of Advanced Combustion Techniques for a Wall-Fired Boiler 3-2, 3-6, 3-8, 3-34
- Demonstration of Coal Reburning for Cyclone Boiler NO_x Control 3-2, 3-6, 3-8, 3-38
- Demonstration of Innovative Applications of Technology for the CT-121 FGD Process 3-2, 3-6, 3-9, 3-28
- Demonstration of Integrated Optimization Software at the Baldwin Energy Complex 2-3, 2-4, 2-18

- Demonstration of Selective Catalytic Reduction Technology for the Control of NO_x Emissions from High-Sulfur, Coal-Fired Boilers 3-2, 3-6, 3-9, 3-54
- Development of Hybrid FLGR/SNCR/SCR Advanced NO_x Control 2-3, 2-4, 2-10
- Development of the Coal Quality Expert™ 3-4, 3-7, 3-8, 3-124

E

- ENCOAL Corporation 3-7, 3-8, 3-128
- ENCOAL® Mild Coal Gasification Project 3-4, 3-7, 3-8, 3-128
- Energy and Environmental Research Corporation 3-6, 3-8, 3-46, 3-76
- Enhancing the Use of Coals by Gas Reburning and Sorbent Injection 3-3, 3-6, 3-8, 3-76
- Evaluation of Gas Reburning and Low-NO_x Burners on a Wall-Fired Boiler 3-2, 3-6, 3-8, 3-46

F

- Full-Scale Demonstration of Low-NO_x Cell Burner Retrofit 3-2, 3-6, 3-8, 3-42

G

- Gilberton Coal-to-Clean Fuels and Power Co-Production Project 2-3, 2-4, 2-36
- Great River Energy 2-3, 2-4, 2-34
- Greenidge Multi-Pollutant Control Project 2-3, 2-4, 2-12

H

- Healy Clean Coal Project 3-3, 3-7, 3-8, 3-114

I

Integrated Dry NO_x/SO₂ Emissions Control System
3-3, 3-6, 3-8, 3-84

J

Jacksonville Electric Authority 2-24, A-5
JEA 2-3, 2-4, 2-24, A-5
JEA Large-Scale CFB Combustion Demonstration
Project 2-3, 2-4, 2-24

K

Kentucky Pioneer Energy IGCC Demonstration Project
2-3, 2-4, 2-28
Kentucky Pioneer Energy, LLC 2-3, 2-4, 2-28

L

LIFAC Sorbent Injection Desulfurization Demonstration
Project 3-2, 3-6, 3-8, 3-20
LIFAC–North America 3-6, 3-8, 3-20
Lignite Fuel Enhancement 2-3, 2-4, 2-34
LIMB Demonstration Project Extension and Coolside
Demonstration 3-3, 3-6, 3-8, 3-68

M

Micronized Coal Reburning Demonstration for NO_x
Control on a 175-MWe Wall-Fired Unit 3-2,
3-6, 3-8, 3-50, 3-80
Milliken Clean Coal Technology Demonstration
Project 3-3, 3-6, 3-8, 3-80

N

NeuCo, Inc. 2-3, 2-4, 2-18
New York State Electric & Gas Corporation 3-6,
3-8, 3-50, 3-80
Next Generation CFB Coal Generating Unit 2-3, 2-26
Nucla CFB Demonstration Project 3-3, 3-7, 3-9,
3-94

O

Ohio Power Company, The 3-7, 3-8, 3-90
Otter Tail Power Company 2-3, 2-4, 2-14

P

Passamaquoddy Tribe 3-7, 3-8, 3-142
Piñon Pine IGCC Power Project 3-3, 3-7, 3-8, 3-100
Public Service Company of Colorado 3-6, 3-8, 3-84
Pulse Combustor Design Qualification Test 3-4,
3-7, 3-9, 3-146
Pure Air on the Lake, L.P. 3-6, 3-8, 3-24

S

Sierra Pacific Power Company 3-7, 3-8, 3-100
SNOX™ Flue Gas Cleaning Demonstration Project
3-3, 3-6, 3-8, 3-64
Southern Company Services, Inc. 3-6, 3-8, 3-9,
3-28, 3-34, 3-54, 3-58
SOx-NOx-Rox Box™ Flue Gas Cleanup Demonstration
Project 3-3, 3-6, 3-8, 3-72
Sunflower Electric Power Corporation 2-3, 2-4, 2-8

T

Tampa Electric Company 2-3, 2-4, 2-16, 3-7,
3-9, 3-104
Tampa Electric Integrated Gasification Combined-
Cycle Project 3-3, 3-7, 3-9, 3-104
ThermoChem, Inc. 3-7, 3-9, 3-146
TIAX, LLC 2-3, 2-4, 2-10, 2-30
Tidd PFBC Demonstration Project 3-3, 3-7, 3-8,
3-90
TOXECON Retrofit for Mercury and Multi-Pollutant
Control on Three 90 MW Coal-Fired Boilers
2-3, 2-4, 2-20
Tri-State Generation and Transmission Association,
Inc. 3-7, 3-9, 3-94

U

Universal Aggregates, LLC 2-3, 2-4, 2-46
University of Kentucky Research Foundation 2-3,
2-4, 2-48

W

Wabash River Coal Gasification Repowering Joint
Venture 3-7, 3-9, 3-108
Wabash River Coal Gasification Repowering Project
3-3, 3-7, 3-9, 3-108, 3-111
Western Energy Company 2-40
Western Greenbrier Co-Generation, LLC 2-3, 2-4,
2-50
Western Greenbrier Co-Production Demonstration
Project 2-3, 2-4, 2-50
Western SynCoal LLC 2-3, 2-4, 2-38
Wisconsin Electric Power Company 2-3, 2-4, 2-20
WMPI PTY., LLC 2-3, 2-4, 2-36