



**National Aeronautics
and Space Administration**

**January 18, 2002
AO 02-OSS-01**

Announcement of Opportunity

Solar Dynamics Observatory (SDO) and Related Missions of Opportunity

**Notice of Intent Due:
Proposals Due:**

**February 20, 2002
April 24, 2002**

TABLE OF CONTENTS

1.0	DESCRIPTION OF THE OPPORTUNITY	1
1.1	Programmatic Background	1
1.2	Scientific Objectives	1
1.3	Non-U.S. Mission Sponsors and Missions of Opportunity	3
1.4	Available NASA Resources.....	4
1.5	Overview of Specific Provisions for Proposals	4
1.6	Overview of Selection of Proposals and Confirmation for Implementation	5
2.0	ANNOUNCEMENT OBJECTIVES	6
3.0	BACKGROUND	7
3.1	Solar Terrestrial Probes and Other Relevant Programs	8
3.2	The Living With a Star Program.....	8
3.3	Programmatic Recommendations to NASA	9
4.0	PROPOSAL OPPORTUNITY PERIOD	10
5.0	REQUIREMENTS AND CONSTRAINTS.....	10
5.1	Description of the SDO Mission.....	10
5.1.1	Candidate Instruments for the Model Payload	10
5.1.2	Description of the NASA-Provided Spacecraft	14
5.1.3	Instrument Accommodation	19
5.1.4	Mission Operations Support	21
5.1.5	Project Schedule	21
5.2	Technical Approach and Management Requirements	22
5.3	International Participation.....	24
5.4	SDO-Related Missions of Opportunity.....	26
5.5	SDO Data Policy.....	28
5.6	Education, Outreach, New Technology, Small Disadvantaged Business Requirements, and Minority Institution Requirements.....	29
6.0	PROPOSAL SUBMISSION INFORMATION	31
6.1	Resources for Additional Information	31
6.2	Preproposal Activities.....	31
6.2.1	Preproposal Conference.....	31
6.2.2	Notice of Intent to Propose	32
6.3	Format, Content, Certifications, and Submission of Proposals	32
7.0	PROPOSAL EVALUATION, SELECTION, AND IMPLEMENTATION	34
7.1	Evaluation Criteria, Factors, and Procedures.....	34
7.2	Selection Procedures.....	35
7.3	Implementation Procedures	36
8.0	SCHEDULE.....	38
9.0	CONCLUSION.....	38

APPENDICES

[Appendix A: General Instructions and Provisions](#)

[Appendix B: Specific Guidelines for Proposal Preparation in Response to this AO](#)

[Appendix C: Bibliography of Relevant Reports and Recommendations](#)

[Appendix D: Certifications](#)

[Appendix E: Education and Public Outreach](#)

THE SOLAR DYNAMICS OBSERVATORY MISSION
AND
RELATED MISSIONS OF OPPORTUNITY

1.0 DESCRIPTION OF THE OPPORTUNITY

1.1 Programmatic Background

The Solar Dynamics Observatory (SDO) is the first Space Weather Research Network mission in the Living With a Star program of the National Aeronautics and Space Administration (NASA). Living With a Star (LWS) is managed by the Sun-Earth Connection Division of the Office of Space Science (OSS) within NASA. The LWS program sponsors the targeted basic research required to develop the scientific understanding necessary to effectively address those aspects of the coupled Sun-Earth system that directly affect life and society. SDO further derives from the strategic element called Solar Near-surface Active-region Rendering (SONAR) in the OSS 2000 Sun-Earth Connection (SEC) Roadmap (see Appendix C for access to this and related documents). LWS generally and SDO in particular also present a singular opportunity for Education and Public Outreach (E/PO). NASA expects to fund the selected SDO investigations as the first mission of the LWS program, consistent with the recommendations of its LWS Science Architecture Team (SAT), the Sun-Earth Connection Advisory Subcommittee (SECAS), the Space Science Advisory Committee (SScAC,) and the recent decadal study for astronomy and astrophysics by the National Research Council.

1.2 Scientific Objectives

The primary goal of the SDO mission is to understand, ideally to the point of predictability, the solar variations that influence life on Earth and humanity's technological systems by determining how the Sun's magnetic field is generated and structured and how this stored magnetic energy is converted and released into the heliosphere and geospace in the form of solar wind (a magnetized plasma), energetic particles, and variations in the solar irradiance (see additional details in Section 2 of this Announcement of Opportunity (AO)). Therefore, this AO solicits proposals to provide complete scientific research investigations that include each of the following elements:

- design, development, and delivery to NASA (or to the sponsor of SDO-related Mission(s) of Opportunity (MO); see further below) of flight experiment hardware in the form of single instruments, suites of instruments, or major components of SDO-related MO instruments;
- design and development of hardware and software to support the reduction, calibration, analysis, distribution, and archiving of the data from the flight SDO instrument(s);
- active participation in mission integration, mission operations, and data acquisition;
- provision in near real time of selected preliminary data products of utility to the LWS, space weather, and general science communities;

- reduction, analysis, distribution, and preparation for archiving of calibrated SDO data;
- analysis and timely publication of research based on the integrated data sets from SDO that address the objectives described in Section 2 of this AO; and
- planning and implementation of an integrated Education and Public Outreach effort.

SDO flight instruments selected in response to this AO will be flown either on a NASA-supplied Sun-pointing spacecraft in geosynchronous orbit that NASA intends to launch in August 2007 for a prime mission of five years, or, in the case of a Mission of Opportunity (see further below), on a spacecraft flown in this same timeframe and provided by an organization other than NASA OSS.

A Science Definition Team (SDT) sponsored by NASA has defined a focused set of scientific objectives for the SDO mission and suggested a prioritized instrument payload that would be sufficient to acquire the data for those science objectives (see Appendix C for information on how to access the SDO SDT Report). The SDO SDT and LWS SAT stress that solving the problems addressed by the LWS program will require a systems approach; therefore, SDO investigations will have to demonstrate how they plan to forge links between disparate targets of study and provide a contextual observational foundation for building bridges that span the interfaces that define the traditional subdisciplines of SEC science. For example, an investigation of spectral irradiance must explore the connections between the photospheric magnetic field and the Earth's atmosphere. Depending on costs of proposals and available resources, NASA expects to select a complementary subset of these science investigations that address most of the highest and perhaps some of the high priority study objectives listed below.

Highest Priority Science Investigations:

- A study of the origins of solar variability using solar oscillations and the longitudinal photospheric magnetic field to characterize and understand the Sun's interior and the various components of magnetic activity using data from what will be generically called a Helioseismic and Magnetic Imager (HMI) for the purpose of this AO;
- A study of coronal energy storage and release evidenced in rapidly evolving coronal structures over a broad temperature range that are intrinsically tied to the Sun's magnetic field and irradiance variations using data from what will be generically called an Atmospheric Imaging Assembly (AIA);
- In concert with other anticipated observations of solar irradiance, a study of both the short- and long-term variations in the full-disk solar irradiance spectrum that arise in response to changes in the Sun's magnetic field, particularly in the extreme ultraviolet (EUV), and are known to cause changes in the Earth's upper atmosphere using data from what will be generically called a Spectrometer for Irradiance in the EUV (SIE); and

- A study of the Sun's transient and steady state coronal plasma emissions that are driven by variations in the solar magnetic field using data from what will be generically called a White-light Coronagraphic Imager (WCI).

Other High Priority Science Investigations:

- A study of physical processes involved in spectral irradiance variations and in impulsive and steady-state energy release in the solar atmosphere related to solar magnetic fields using data from what will be generically called an Ultraviolet (UV)/EUV Imaging Spectrograph (UIS);
- A study of the underlying origins of solar irradiance and luminosity variations and thermal structures associated with magnetic field structures using data from what will be generically called a Photometric Imaging Telescope (PIT); and
- A study of magnetic stresses and current systems in the photosphere associated with impulsive events and evolving magnetic structures using data from what may possibly be an enhancement of the HMI and will be generically called the Helioseismic and Vector Magnetic Imager (HVMI).

SDO investigation teams must be led by a single Principal Investigator (PI) who may be from any category of public or private U.S. or non-U.S. organization (see Section 5.2). In addition, the science team for an investigation may be formed from any combination of institutions, public or private, domestic or foreign.

1.3 Non-U.S. Mission Sponsors and Missions of Opportunity

Proposals for SDO science investigations are encouraged under a no-exchange-of-funds basis from non-U.S. organizations (see Section 5.3). Non-U.S. investigations are expected to meet all data policies and program objectives described in this AO, but do not have to meet the NASA requirements for infusion and transfer of new technology, or enhancing education and public outreach in the U.S. However, note that the level of detail required in a proposal is the same no matter what organizations are partners in its team. The only exception to this rule is that non-U.S. organizations do not need to submit detailed budget statements for costs incurred in their own nations (see further information for non-U.S. proposals in Section 5.3).

This AO also solicits investigations that can take advantage of Missions of Opportunity (MO's; see Section 5.4) that effectively fulfill one (or more) SDO objectives with an instrument(s) that is(are) carried on a mission(s) sponsored by an organization(s) other than NASA's Office of Space Science. Such SDO MO's are expected to meet all data policies and program objectives described in this AO, and all domestic SDO MO's must also meet the stated objectives for the infusion and transfer of new technology, as well as enhancing education and public outreach.

1.4 Available NASA Resources

Proposing scientists must recognize that the resources available for participation are cost constrained and propose accordingly. As a guideline, the total cost to NASA of all investigations selected through this AO from Phase A through Phase E (see definitions in Section 1.5) is approximately \$123M in real year \$US, including proposers' contingencies. Of this amount, approximately 6% is allocated for firm, fixed-price Phase A contracts for studies. In any event, the continuation of any aspect of this program shall be contingent upon the availability of appropriate NASA funding through the yearly Federal budget process.

1.5 Overview of Specific Provisions for Proposals

This AO solicits proposals for scientific investigations from individual Principal Investigators (PI's), aided by a number (see Appendix B, Section C.2.d) of Co-Investigators (Co-I's), that provide, as well as utilize, the data from the proposed hardware. Proposed investigations may provide individual instruments or various combined sets (i.e., suites) of instruments up to and including an entire complement of integrated instruments sufficient to satisfy all the science objectives of the entire mission. However, while proposals for multiple instruments are not disallowed, they must provide technical and cost information for each instrument sufficient to allow for separate evaluation.

Additionally, investigations proposed to achieve the stated SDO science objectives through participation in Missions of Opportunity may be selected if their perceived value is high, their performance is within the stated time period desired for the SDO program, and the proposed NASA cost is within the funding limits of this mission.

Proposals submitted in response to this AO must be for complete science investigations, as defined in Section 1.2, and encompass all SDO mission phases as follows (see also Section 1.6 for further information):

- Phase A – concept definition study, culminating in an Initial Confirmation Review (ICR), and, if successful, a decision to fund Phase B studies;
- Phase B – concept development and preliminary design, culminating in a Preliminary Design Review (PDR), a Non-Advocate Review (NAR) and, if successful, approval for implementation;
- Phase C – implementation of detailed design and development, culminating with components ready for integration,
- Phase D – integration, testing, and launch (nominally August 2007) through launch plus 30 days; and
- Phase E – mission operations (prime mission of five years from launch plus 30 days) and data analysis for six years from the time of launch.

Phase E is to include provision of data for public use, analysis and publication of data in the peer-reviewed scientific literature, and delivery of the reduced, calibrated data to the appropriate NASA-specified data archive. The planning, design, and implementation of

an appropriate E/PO program should be an integral element during all mission phases (see Section 5.6 and Appendix E).

1.6 Overview of Selection of Proposals and Confirmation for Implementation

NASA reserves the right to make partial selections of investigations, as described in Section II of Appendix A. Proposals to this AO will be selected through a single-step process for a Phase A study only. In addition, NASA reserves the right to make tentative selections pending the outcome of Phase A studies (see Appendix A, Section II). At the end of the Phase A studies, a review will be held to decide which investigations will be further funded for Phase B study. The contracts of those not so funded will be terminated from further participation in this program. Confirmation for implementation will be made at the end of the Phase B study, and the contracts of those not confirmed for implementation will be terminated from further participation in this program. Implementation plans generated during these Phase A and B study periods as documented in the reports from those Phases will be assessed at the appropriate Confirmation Review or NonAdvocate Review (NAR). The primary discriminator for selection and confirmation for implementation will be based on how well each investigation contributes to the overall scientific objectives of the SDO mission as constrained by technical, schedule, and cost considerations. However, as noted in Section 7, E/PO will also continue to be used as a discriminator.

Proposers must estimate the Total NASA Cost (all costs necessary to complete the investigation beginning with Phase A through Phase E, including reserves) in their proposals and, if selected through this AO, in a much more detailed cost proposal that will be requested at the same time as the Phase A concept study report. Investigators should cost their Phase E efforts to provide for the entire analysis effort for their investigations during the first two years after launch. Less funding will be provided for the selected investigations for subsequent years; in particular proposers should reduce their Phase E budget by ~50% for years three to six. Additional science analyses using equivalent resources are expected to be competed in an LWS Guest Investigator program that will be advertised by NASA. The specific cost information required for proposals to this AO is described in Appendix B. During no phase of the investigation shall the estimated cost to NASA of the total for all investigations exceed the NASA cost constraint for this mission. Individual investigations may be descope or terminated by NASA to meet cost constraints. Therefore, the proposers must describe a management approach that identifies a prioritized plan for removal of science objectives including the decision point and estimated cost savings for each descope.

The SDO Project Office will implement a balanced reserves strategy that affords flexibility in the design and development while minimizing risk throughout the project. Proposers shall outline their reserves plan indicating the appropriate amounts of technical, schedule, and cost reserves based on design maturity and flight heritage. The Project Office will allocate reserve levels for each selected investigation and delegate management of reserves to the PI. Proposers should not assume that the Project Office will maintain any reserves beyond those allocated.

2.0 ANNOUNCEMENT OBJECTIVES

The primary goal of the SDO mission is to understand the mechanisms of solar variability well enough to quantify the Sun's influence on global change and improve our characterizations and forecasts of Earth's space weather. To accomplish this, SDO must make significant progress on two key objectives:

- First and most important, SDO investigations should determine how and why the Sun varies. Since the critical mechanisms of solar variability are ultimately controlled by the Sun's magnetic field, SDO must provide new understanding of three interlinked magnetic processes that act on separate time scales – namely, the solar cycle that operates on time scales of months to centuries; solar active regions that emerge in hours and have time scales measured in weeks to months; and small-scale magnetic elements that account for the vast majority of solar magnetic energy but live for only a few hours.
- Second, SDO investigations must improve our understanding of how the Sun actually drives global change and space weather. The three important inputs to the terrestrial environment are electromagnetic radiation, energetic particles, and variations in the solar wind. Therefore, SDO must provide the new observations of the dynamic solar atmosphere and interior required to advance our understanding of the sources of 1) irradiance variations that are vastly different in various parts of the spectrum, 2) energetic particles from solar flares and shocks that ultimately result from explosive conversion of the Sun's magnetic field energy, and 3) variations in the solar wind due to coronal mass ejections (CME's), as well as slower variations in coronal structure not related to explosive events.

SDO investigations must acquire those data that allow the physical parameters of the dynamic solar interior and atmosphere to be measured and quantified and then allow development of the scientific and analytical skills necessary for understanding these data in terms of basic physics that relate to the control of the Earth's space environment and weather. The intent is to develop dynamical, quantitative, physical descriptions of the magnetic field of the Sun and its internal material flows and rotation, as well as descriptions of the processes that generate regions of activity on all size scales, disturbances in the heliosphere, and the variable space environment of the Earth for physical insight to space weather and solar influences on global change.

SDO investigations seek to explain the dynamo at the base of the convection zone that drives the solar magnetic cycle; the multiple complex processes that form, emerge, concentrate, and eventually disperse the magnetic flux in active regions; the near-surface sources of small-scale magnetic structures; and the interactions of large and small magnetic patterns that lead to coronal heating, solar wind acceleration, explosive events, and the transformation of the coronal field topology. SDO investigations will help develop the capability to first identify and ultimately support forecasting of conditions that lead to the storage and release of energy in the form of irradiance changes and solar energetic events, such as flares and CME's. SDO should also provide information about the origins of the solar wind to support forecasting of the variability that ultimately

influences the geospace environment. To contribute to this understanding and to provide context for other LWS investigations, SDO needs to provide a means for tracking and characterizing coronal mass ejections and other features in the corona. Similarly, the primary solar influence for global change is irradiance variations; SDO investigators must fill a gap in our knowledge of the spectral irradiance variations in the extreme ultraviolet that drive many of the processes in the Earth's uppermost atmosphere.

The SDO mission faces a challenging task and it is impossible to make a one-to-one link between instruments and these objectives. Unfortunately NASA probably cannot afford to fund all of the instrument investigations listed in Section 1, nor is it likely that the SDO spacecraft will be capable of accommodating all of the instruments listed (see Section 5.1). Therefore, other concurrent space missions and ground-based observatories will be relied on to measure many aspects of the interconnected Sun-Earth system (see Section 3). With this in mind, proposers are encouraged to describe how their investigation would contribute to the anticipated program and show how their investigation would address the broadest range of LWS and SDO science goals for the minimum cost.

Given the broad and immediate relevance of improved understanding of the Sun's variability and its effects on humanity, progress on the SDO scientific objectives will allow the mission to achieve another of its major goals: communicating with the public and supporting the formal U.S. education system (see Section 5.6).

The report of the SDO Science Definition Team provides a more detailed description of the overall mission and additional background information that may be useful to the proposers who seek to respond to this solicitation. Appendix C provides instructions on accessing various elements of the SDO Library; proposers unable to access the World Wide Web (WWW) can request a hard copy of the SDO SDT Report by sending E-mail to deb.tripp@hq.nasa.gov. However, in case of a conflict between concepts outlined in this AO and those in the Science Definition Team report, the provisions of this AO take precedence. In particular, to be considered responsive to this Announcement, proposed investigations must address the objectives described here in Section 2.

3.0 BACKGROUND

NASA's Sun-Earth Connection (SEC) Division seeks to better understand why the Sun varies; how the Earth and other planets respond; how solar variability affects Earth's climate, life, and society; and how the heliosphere interacts with the galaxy. The Sun is a variable star whose energy output varies on all time scales. The Earth, planets, and other bodies reside within the Sun's outward flowing atmosphere. This solar wind, consisting of plasma, energetic particles, and magnetic fields, is the extension of the Sun's corona whose outer boundary defines the heliosphere. By analyzing the connections between the Sun, solar wind, planetary space environments, and the Galaxy, SEC science works to explain the fundamental physical processes that occur throughout the Universe. These four broad Quests are more fully described in the *Sun-Earth Connection Roadmap: Strategic Planning for 2000-2025* (see Appendix C for access to this and related documents).

The SEC Division science program sponsors missions in two programs: Solar Terrestrial Probes (STP) and Living With a Star (LWS). These are in addition to the more widely competed Explorer opportunities.

3.1 Solar Terrestrial Probes and Other Relevant Programs

The STP program addresses the full spectrum of SEC goals with a sequence of strategic research missions meant to answer tightly focused science questions. STP missions that are expected to operate concurrently with SDO are Solar-B (sponsored jointly by Japan's Institute of Space and Astronautical Science (ISAS) and NASA), the Solar Terrestrial Relations Observatories (STEREO), the Magnetospheric Multi-Scale (MMS) mission, the Geospace Electrodynamics Connections (GEC) mission, and the Magnetospheric Constellation (MagCon) mission.

Additional ground-based and space-based programs should also complement the observations provided by SDO. These include:

- the Solar Radiation and Climate Explorer (SORCE), sponsored by the NASA Office of Earth Science;
- the Geosynchronous Operational Environmental Satellites (GOES) and National Polar-Orbiting Operational Environmental Satellite System (NPOESS), both sponsored by the National Oceanic and Atmospheric Administration (NOAA);
- the Solar Orbiter mission that will launch after 2008 sponsored by the European Space Agency (ESA);
- the Global Oscillations Network Group (GONG) and the nearly completed Synoptic Optical Long-term Investigations of the Sun (SOLIS) program, both sponsored by the U.S. National Science Foundation (NSF); and
- the Advanced Technology Solar Telescope (ATST) and the Frequency Agile Solar Radiotelescope (FASR), both of which have been proposed to NSF in keeping with recommendations in the recent NRC Astronomy Decadal Survey.

3.2 The Living With a Star Program

The LWS program sponsors targeted basic research that addresses that subset of SEC science specifically required to develop knowledge and understanding of aspects of the connected Sun-Earth system that directly affect life and society. In particular, LWS seeks to:

- Understand solar variability and its effects on space and Earth environments;
- Provide information for mitigating effects of solar variability on technology; and
- Determine how solar variability can affect life on Earth, and specifically:
 - Understand the relative importance of global climate changes caused by the Sun and other natural and anthropogenic drivers; and
 - Predict how stellar variability may affect life in other stellar systems.

LWS includes four major elements: 1) a Space Weather Research Network of solar-terrestrial spacecraft; 2) a Targeted Research and Technology (TRT) program; 3) a Space

Environment Testbeds (SET) program to infuse new technologies into space programs; and 4) development of partnerships with national and international agencies and industry.

SDO is the first mission element of the Space Weather Research Network recommended in NASA's Space Science Enterprise Strategic Plan and endorsed by the LWS Science Architecture Team (SAT) to accomplish the goals of the LWS program. The other future LWS efforts are:

The LWS Geospace Plan – To begin development of physics-based and empirical models, the Geospace Mission Definition Team (GMDT) is following the lead of the LWS SAT. The GMDT is defining a plan that is integrated with the rest of the SEC program and includes a Geospace Missions Network, Missions of Opportunity, and Leveraged Programs. SDO is a potential mission of opportunity for LWS Geospace measurements.

LWS Sentinels – As currently envisioned, Sentinels will probe the connections between solar phenomena and geospace disturbances using multiple spacecraft in different heliocentric orbits to determine: 1) the structure and long-term variations of the solar wind; 2) how solar wind structures propagate and evolve between the Sun and Earth; 3) which solar dynamic processes are responsible for the release of geo-effective events; and 4) how and where energetic particles are released and accelerated. A Farside Sentinel will image the other side of the Sun. Coordination with International Living With a Star partners, e.g., ESA's Solar Orbiter mission, will influence the mission architectures of the LWS Sentinels.

While these missions individually would doubtless produce exciting discoveries about the complex Sun–Earth system, together they are a formidable fleet that will greatly improve the ability to predict weather in space, enhance knowledge of solar influences on climate change, and give fresh insight into the origins and future of life on Earth.

3.3 Programmatic Recommendations to NASA

The ability of NASA space missions to study the dynamic magnetic processes beneath the visible surface of the Sun and their impact on geospace is a recent development. However, the physical processes leading to solar variability and eruptive phenomena have been of great importance to the U.S. solar space program ever since the first observations in 1973 by instruments on NASA's Skylab/Apollo Telescope Mount. Changes in the ultraviolet input to Earth, caused either by radiance changes or varying apparent size of the Sun, have been measured only more recently. The report of the *National Space Weather Program Implementation Plan, July 2000* (FCM-P31-2000) explicitly recommended flight of a suite of instruments that would provide detailed information on the dynamics of the solar interior and dynamo that generate and control solar variability. SDO is derived from the SOLar Near-surface Active-region Rendering (SONAR) mission, a strategic element of the *2000 Sun-Earth Connection (SEC) Roadmap* (see Appendix C for access to this and related documents). The Roadmap advocated this mission for breakthrough science and progress toward reliable space weather forecasts.

In view of the high data rate and measurement continuity required for this mission, a geosynchronous platform with a dedicated ground station was recommended. Subsequently, the *Space Science Enterprise Strategic Plan (2000-2025)* confirmed SDO as the initial trail-blazing mission of the LWS initiative and this has been supported by the LWS SAT and the Sun-Earth Connection Advisory Subcommittee (SECAS). The SDO Mission was also endorsed in the National Research Council's decadal survey planning report, *Astronomy and Astrophysics in the New Millennium* (NAS, 2001).

4.0 PROPOSAL OPPORTUNITY PERIOD

This Announcement of Opportunity solicits proposals for a single opportunity in accordance with the schedule given in Section 8.

5.0 REQUIREMENTS AND CONSTRAINTS

5.1 Description of the SDO Mission

The subsections below present the results of a mission implementation concept study that will achieve the scientific goals described in Section 2 of this AO. The topics include descriptions of a model payload, some details of a NASA provided spacecraft, provisions for instrument accommodation, a scenario for mission operations support, and a mission schedule.

The interfaces and performance envelopes indicated in this AO are preliminary and should be expected to evolve after the investigations are selected and the instruments are further defined, the spacecraft is designed, and design trade-offs are made. Therefore, successful proposers should expect to revise their designs as needed to meet different spacecraft and mission requirements and specifications. Any modifications to the specifications in this AO will be posted at the WWW location where this AO is posted, http://research.hq.nasa.gov/code_s/open.cfm. For evaluation purposes, proposals will be judged against amended interface and performance specifications provided at the above web site.

5.1.1 Candidate Instruments for the Model Payload

In order to give prospective proposers the fullest possible understanding of the SDO mission, this section provides a description of one possible instrument complement that can achieve all the mission science objectives. This model payload is based on the SDO SDT report and is larger than the complement that NASA expects to be able to select. The list of candidate instruments is not intended to restrict the possible approaches, nor is the list intended to preclude consideration of investigations that propose other instruments or combinations of instruments that can provide the necessary observations. The list simply describes a sample instrument complement that is expected to be able to meet the mission science objectives. In all cases, however, it is emphasized that this AO solicits complete science investigations, of which these model instruments are only one

means for obtaining the necessary data. The relative priorities of these investigations are discussed in Section 1.

To meet anticipated instrument boresight pointing requirements, an interface to the spacecraft attitude control system will be provided to accept fine-guider pointing-error signals from the instrument payload (see Section 5.1.2). Since the Guide Telescope must be implemented within the available resources for this AO, proposals for the Guide Telescope are welcomed from proposers of any SDO instrument. If proposed, cost and resources associated with the Guide Telescope must be clearly identified as separable items.

Table 5-1: Nominal Instrument Resources (Including Reserves)

SDO Concept Instrument [□]	Mass (kg)	Average Power (Watts)	Data Rate (Mbps)	Envelope* (cm)	Remarks
HMI	54	57	29	90x40x25 sensor box	
				45x22x29 elec. box	
AIA [†]	66	140	58	100x15x25 sensor box	Sensor box envelope is for single telescope
				44x27x29 elec. box	
SIE	26	52	2	44x24x21 sensor box	Sensor envelope is for single telescope
				25x23x18 elec. box	
WCI	28	51	16	135x17x17 sensor box	
				25x23x18 elec. box	
UIS	58	63	23	150x50x50 sensor box	
				40x23x18 elec. box	
PIT	38	59	4	100x30 dia. sensor box	
				25x28x28 elec. box	
HVMI	63	78	55	70x40x35 sensor box	Replaces HMI if selected
				45x22x29 elec. box	
Concept Instrument Total	279	443	158		AIA, SIE, WCI, UIS, PIT, and HVMI
Baseline Spacecraft Capability [‡]	225	350	150		For all instruments including reserve

[□] Note: See instrument definitions in Section 1.2

* Note: First dimension is the Sun-pointing direction.

[†] Note: AIA mass, power, and telemetry are for a 5-telescope array.

[‡] Note: Spacecraft baseline cannot support full instrument complement as presented.

A preliminary engineering evaluation was performed to determine resources available to the SDO science payload, as well as resource estimates for the individual candidate instruments. Table 5-1: Nominal Instrument Resources is provided as a guideline to

allow development of resource requirements compatible with the concept spacecraft capabilities. Note that the resource estimates for the complete model payload exceed the baseline spacecraft capabilities. More efficient instrument design may allow selection of a more complete payload. Although the dimensions shown are to be regarded as guidelines, there is a nominal 1.5 m limit on the instrument Sun-Pointing dimension. Any significant updates to this information will be made available at the WWW location where this AO is posted.

HMI – Helioseismic and Magnetic Imager

It is anticipated that a single HMI instrument should be able to provide observations of both solar oscillations and the longitudinal photospheric magnetic field.

This instrument should provide data for near-surface diagnostics of the dynamics of the solar interior for understanding solar variability. Measurements should be sufficient for both global and local helioseismology techniques that probe conditions throughout the Sun. These objectives require full-disk, 1-arcsec resolution oscillations images obtained at least every 50 sec. These requirements are driven by the known frequencies of the solar oscillations and the need for sufficient resolution out to 75 degrees heliographic from disk center. If the oscillations are measured in velocity, SDO's geosynchronous orbit requires a dynamic range of about 13 km/s and a per pixel velocity precision of roughly one part in a thousand. Helioseismology requires 99.99% data recovery about 95% of the time on all temporal scales.

This instrument can also provide the required information about the global solar magnetic field, active region evolution, and complete coverage of small-scale features as well as the sources of irradiance variations. Continuous observations of the longitudinal solar magnetic field from space are essential to understanding the mechanisms of solar variability. This objective requires full-disk, 1-arcsec resolution magnetic images approximately every minute. Measurement of these features requires a precision of five Gauss (G) every five minutes with an accuracy of about 0.1 G and a dynamic range of several thousand Gauss.

AIA – Atmospheric Imaging Assembly

This instrument will characterize the rapid evolution of plasma in the chromosphere and lower corona and will help interpret the EUV spectral irradiance measurements. Simultaneous full-disk 1.2-arcsec resolution images of the solar atmosphere in several wavelengths spanning the temperature range 20,000 to 4 million Kelvin (K) should be sufficient. An array of several telescopes may be required to provide ~10 sec cadence images in multiple temperatures required to understand rapid heating and cooling. In any event, intercalibration of intensity between the images to ~10% is necessary to derive sufficiently accurate physical characteristics in important features, and sufficient dynamic range in each temperature range should be provided to measure the full range of emission and absorption features exhibited by the dynamic Sun. The field of view of the AIA in appropriate temperature regimes should extend well above the limb to facilitate linkage with white-light coronagraph (see below) observations. The spectral resolution of the

images should be sufficiently narrow to separate the physically important temperature ranges.

SIE – Spectrometer for Irradiance in the Extreme-Ultraviolet

This instrument provides continuous observations of the full-disk solar extreme ultraviolet (EUV) irradiance that causes variations in composition, density, and temperature of the Earth's ionosphere and thermosphere. Accurate measurements in the 1 to 120 nm range are required to identify variations in important spectral lines and continuum emission for input to ionospheric and upper atmospheric models important for the LWS Program. The SIE field of view should be sufficient to measure off-limb contributions to irradiance. The required spectral resolution is estimated to be 0.1 nm in much of the range longward of 10 nm. The time cadence should be sufficient to facilitate coordination with the cadence of SDO's Atmospheric Imaging Assembly (AIA). Accuracy of 10% is desirable, with a goal of 5% for calibrated long-term stability.

WCI – White-Light Coronagraphic Imager

This standard heritage instrument measures polarized intensity in white light to characterize variations in coronal structure and to detect coronal mass ejections -- those on the limb as well as "halo" events directed more nearly along the Sun-Earth line. A time resolution of about five minutes with a resolution of 30 arcseconds in the range 2.5 to 15 solar radii should be adequate to provide the contextual information required for the SDO and STEREO missions, as well as other LWS science objectives. A calibrated intensity precision of 10% and a dynamic range of four orders of magnitude should be sufficient to capture most variations in the outer corona.

UIS – UV/EUV Imaging Spectrometer

This instrument measures line profiles that reveal dynamic properties of the magnetic solar atmosphere from the photosphere into the corona in the region where EUV irradiance originates, flares and coronal mass ejections are triggered, and the solar wind accelerates. Line intensity accuracy should be sufficient to help interpret EUV irradiance measurements. Measurement of line widths to 10% and Doppler shifts to a few km/s should provide information sufficient to characterize the dynamic events observed by the AIA, provided measurements are made with comparable time cadence, spatial resolution, field of view, and in the same temperature range. Images would likely be built up over time by rastering or other techniques. UIS is the only SDO concept instrument that requires regular target selection; therefore, any proposed investigation incorporating an instrument like this would need to budget for additional project costs associated with increased science and mission operations complexity (see Section 5.1.4).

PIT – Photometric Imaging Telescope

This new type of instrument provides two measures of photometric intensity over the full solar disk every minute in order to determine the origins of solar luminosity and irradiance variability and to reveal any deep-seated thermal structures that may be

associated with the solar cycle and/or active regions. The first objective requires high (i.e., approximately 0.1%) precision, 1-arcsec resolution images, in order to identify relatively narrow wavelength band brightness variations associated with surface magnetic and convective features. The second objective can be achieved with much coarser spatial resolution, but the detector must be sensitive to radiation of essentially all wavelengths, with a bolometric precision at the 3% level. Depending on its design, this instrument could also provide observations of the Sun's shape and size at the 10-milliarcsec level necessary to distinguish between models of solar cycle luminosity variations.

HVMI – Helioseismic and Vector Magnetic Imager

This instrument provides vector photospheric magnetic field observations over the whole disk with 1-arcsec resolution every 10 minutes and could be an inexpensive optional modification of HMI. Precision of the transverse field direction to a few degrees requires polarization measurements at the level of about one part in 10,000 and precision in the transverse field of about 50 G, which should be sufficient to complement high-resolution, restricted field-of-view Solar-B and less frequent SOLIS measurements of the vector field. These observations are required to detect nonpotential field structures associated with evolving magnetic structures in the solar atmosphere.

5.1.2 Description of the NASA-Provided Spacecraft

NASA's SDO Project Office at the NASA Goddard Space Flight Center has developed a spacecraft concept based on preliminary engineering analysis. Figure 5-1: Spacecraft Concept Sketch depicts the concept spacecraft and its housing in the shroud of its launch vehicle.

The mass, power, and data rate allocations listed in Table 5-1 include reserves to be managed by the proposers. The power allocation includes the power for operational heaters. Proposers shall determine and propose the appropriate amount of reserves based on design maturity, flight heritage, and risk.

Proposed instrument and resource requirements will be reviewed for compatibility with the spacecraft and launch vehicle interfaces during Phase A studies (see Section 1.5). Ultimately, interfaces and resource allocations will be documented in Interface Control Documents (ICD's) between the instruments and the spacecraft.

In the baseline concept, the SDO spacecraft is placed into a nominal 28.5 degree inclination, geosynchronous transfer orbit (GTO) by a medium-class Expendable Launch Vehicle (ELV). At separation from the last stage, depending on the launch scenario, the

Figure 5-1: Spacecraft Concept Sketch

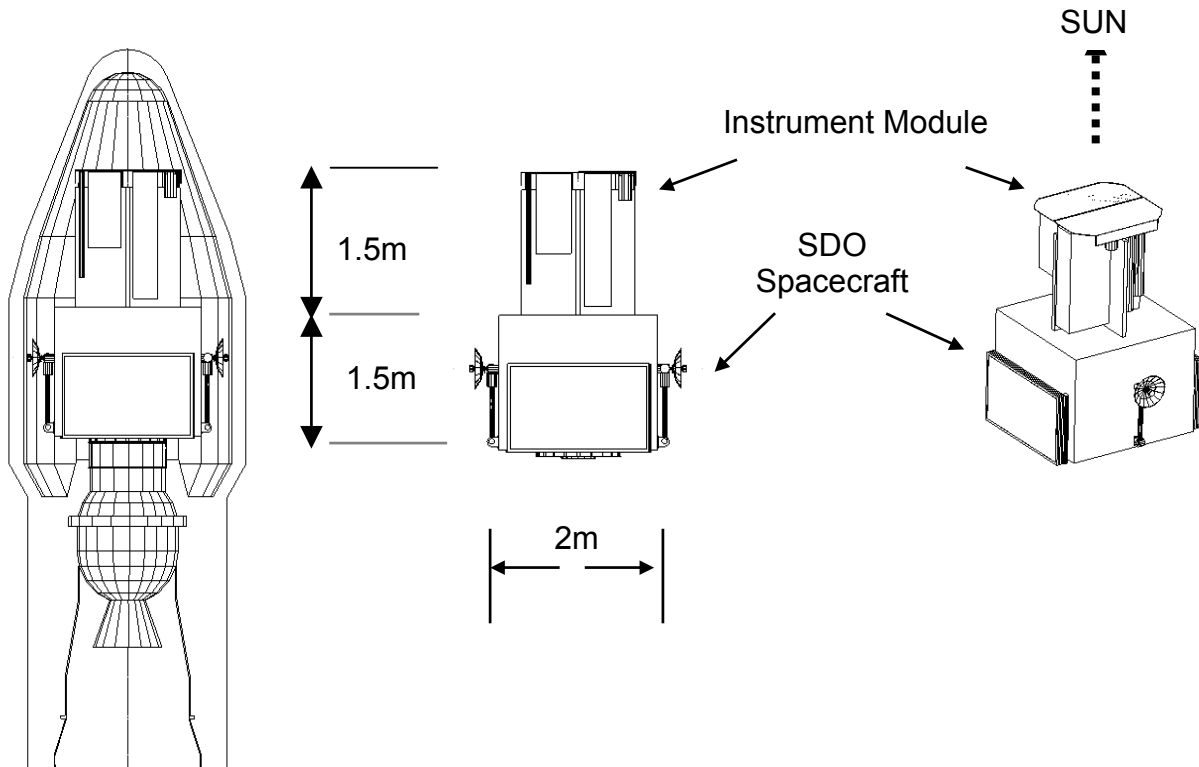

spacecraft is either spinning approximately once per second or 3-axis stabilized. Using an onboard apogee kick motor or propulsion system, the spacecraft adds the delta-V needed to achieve the desired geosynchronous mission orbit and is then positioned over the desired meridian. The spacecraft is not required to compensate for inclination insertion errors. Once in the proper orbit, the spacecraft is 3-axis stabilized with the appropriate axis pointed to the Sun. From time to time the spacecraft is required to perform station-keeping maneuvers. The orbit causes the spacecraft to enter the Earth's shadow during two yearly eclipse seasons, with a maximum shadow period of approximately one hour per day (see the SDO SDT report for more orbit information).

The underlying philosophy of the SDO spacecraft design will be to develop the instrument-to-bus interfaces to maximize efficiency during the prelaunch integration of the observatory. Instrument interfaces include optical, mechanical, electrical, thermal, and data (see further information below in this section). Communication services will consist of relaying commands and telemetry to and from the instruments, with no data processing or science data storage provided by the spacecraft or the mission operations center. Any additional interfaces or requirements proposed must be fully explained and justified in the proposal.

The baseline mission life of SDO is five years. Spacecraft consumables will be sized accordingly, with ample margins.

Spacecraft/Instrument Interfaces

The interfaces between the spacecraft and the instruments are expected to consist of the following:

- Main power to the instruments,
- Survival heater power to the instruments,
- MIL-STD-1553B Command and Telemetry Data bus,
- Pointing error signals from one of the scientific instruments (Guide Telescope),
- Low Voltage Differential Signal (LVDS) Science data bus from each instrument to the spacecraft (or equivalent), and
- Survival temperature monitors back to spacecraft.

Other than the electrical interfaces listed above, no individual discrete or analog interfaces connect the spacecraft and the instruments. The only reset to the instrument electronics occurs via a "Power On" command or 1553 command. The spacecraft will accept pointing errors only from the Guide Telescope. All data communications between the instruments and the spacecraft will be via the Command and Telemetry bus and/or the Science data busses. Any instrument not compatible with these busses must incorporate suitable converters in their electronics. Science data formatting and header data will be supplied by the spacecraft.

Electrical Interfaces

The spacecraft will supply each instrument with unregulated 28 Volt DC power from separate Main Power and Survival Heater buses. The spacecraft will maintain the voltage on each bus between 21 and 35 Volts DC.

The spacecraft will control the Main Power bus switching for each instrument, and each of these circuits will be individually protected on the spacecraft side. The spacecraft will use the Main Power feed to power the instruments except for the survival heaters. The Survival bus will be used to power the survival heaters. Power from the Survival bus will be constantly available throughout the entire mission, with the exception of the launch phase. Each of the instrument providers shall be responsible for determining the instrument survival temperature and for providing thermostats and heaters mounted within the instrument to maintain it. Survival temperature is defined as the lowest temperature to which the instrument can be subjected and still be able to operate within its performance specification when brought back to its operating temperature. The orbital average power to the instrument complement shall not exceed 350 Watts, including reserves. The survival power shall not exceed 50 Watts. The instrument suppliers are required to maintain their own power reserves, which should be based on the level of design maturity.

Bus Architecture

A MIL-STD-1553B data bus is the primary method for command and telemetry transfers (low rate data) between the spacecraft and the instruments. The high rate data from each of the instruments shall be transmitted to the science data formatter, supplied by the spacecraft, via a dedicated LVDS bus or equivalent to be specified in Phase A. Data from the instruments may be serial or parallel, depending on the data rate.

The spacecraft computer controls all observatory operations. For the instrument, the spacecraft computer provides commands, collects and stores telemetry, distributes time, provides data quality flags, and issues safing and keep-alive signals.

Reaction Control System

The spacecraft will have a monopropellant reaction control system for momentum unloading and station keeping. If necessary, the ground can inhibit thruster firings until a favorable time is reached when the science impact will be minimal. The instruments will be informed of the planned firings via the 1553 command and telemetry bus.

Electromagnetic Cleanliness

The SDO platform may be a mission of opportunity for LWS geospace instruments that may be procured through a separate solicitation, for example particle, plasma, and field detectors. Therefore, reasonable care should be taken in the design of instruments to minimize stray electromagnetic fields, although no specific requirement is imposed.

Pointing Knowledge and Control

During normal science operations, four reaction wheels will control the spacecraft attitude. To meet the expected tight instrument boresight pointing requirements, an interface to the spacecraft attitude control system will be provided to accept fine guider error signals. The Guide Telescope signal characteristics shall support the instrument pointing requirements. Table 5-2 provides Guide Telescope characteristics identified during the NASA mission implementation study and Table 5-3 gives the expected pointing capability of the SDO spacecraft.

The values shown in Table 5-3 for Pointing Accuracy, Knowledge, and Stability pertain to the angular motions of a rigid plane formed by the principle instrument attachment points. They do not include pointing errors caused by electrical, optical, mechanical, and/or thermal effects internal to the instrument. The Accuracy and Knowledge values pertain to the long-term angular motion, whereas, the values shown for Stability are the angular deviations of the principle plane over a 45 second observation period. Although the Stability errors have not been apportioned, it is anticipated that these errors will be with respect to a local reference.

Table 5-2: Guide Telescope Characteristics

Characteristic	Description
Accuracy in 2 axes	0.1 arcsec, 3 sigma with respect to the Sun line *
Bandwidth	Updated at 50 Hz.
Noise Equivalent Angle (NEA)	0.01 arcsec, 3 sigma
Linear range	±10 arcsec
Error signal range	±100 arcsec
Latency	0.1 seconds

* Sun line is defined as the bisector of the Sun's angular subtense (formed by the limbs) measured from the spacecraft.

Table 5-3: Spacecraft Pointing

Accuracy	Pitch, Yaw, & Roll *	50 arcsec **
Knowledge	Pitch, Yaw, & Roll *	25 arcsec **
Stability over 45 seconds	Pitch, Yaw, & Roll *	5.0 arcsec **

* Roll is about the Sun line

** All values shown are 3 sigma

Alignment

Ground knowledge of instrument co-alignment should be assumed to be 30 arcseconds. Launch shifts and thermal deformations with respect to the spacecraft master optical alignment cube are budgeted to be 1 arcminute. Instruments requiring prelaunch alignment must provide an optical cube mounted to the outside of the instrument that is mapped to the boresight of the instrument. Instruments requiring better on-orbit alignment must provide their own method of adjustment or correction through mounting leg mechanisms or data calibration. Note that calibrations requiring offset pointing from the Sun may compromise the thermal stability of the instrument interface, resulting in operational impacts.

Jitter

The Pitch and Yaw jitter performance of the observatory is driven by the Guide Telescope noise and the response of optics and structure to disturbances such as the gimballed High Gain Antenna and reaction wheel imbalances. Because the observatory is Sun-pointing and rarely enters the umbra of the Earth, thermal bending and snaps are not considered to be jitter producers during the normal mode of operation.

Generally, stability is the angular deviation caused by disturbances with long time scales, and jitter is considered to be the angular variations due to higher frequency disturbances.

The spacecraft time-varying pointing requirement spans both of these regions. Therefore, the jitter requirement is incorporated within the stability requirement.

5.1.3 *Instrument Accommodation*

The shared 1553 data bus provides command and low rate data (housekeeping/safety) telemetry between the spacecraft and instruments. The spacecraft acts as the bus controller and each instrument is a remote terminal. Data transfers are packetized and are formatted using the Consultative Committee for Space Data Systems (CCSDS) packet protocol.

The spacecraft will support uplink rates at 2 Kbits/s (normal). During normal operations, the downlink data is continuously transmitted at 150 Mbits/s in the Ka band, 24 hours a day. During normal operations, the spacecraft accepts commands at the 2 Kbits/s rate concurrently with telemetry downlink.

The spacecraft will send command packets to the instruments without processing. Uploads will be scheduled once per day. After on-orbit checkout, the ground station will only be staffed eight hours per day, five days per week, and will be unstaffed at all other times except for emergencies. It is the responsibility of each instrument team to define the formats of the data portions of its command packets. The spacecraft will not generate instrument commands autonomously.

The spacecraft will support limited storage of command packets for distribution to instruments at a later time. Stored command packets may be individually time tagged with one second precision, or may be part of a macro sequence. Approximately one megabyte of memory may be available to all instruments for stored commands. Allocation of this memory will be made during Phases A and B.

An unpacketized broadcast message to all instruments will be distributed once per second. This message will contain:

- Time synchronized to International Atomic Time (TAI) with 10 ms accuracy;
- Warning flags for:
 - Thruster firing and
 - Instrument Power-Off; and
- Spacecraft housekeeping data required for instrument science.

The spacecraft will collect science data from the instruments via a LVDS bus, or equivalent, and housekeeping and safety telemetry via the 1553 data bus. Data from the instruments will be sent in real time to the ground and will not be stored. Each instrument must generate its own science packets. The spacecraft command and data handling processor will frame and append Virtual Channel Data Unit headers prior to encoding for transmission to the ground.

The spacecraft will not process instrument data on board prior to down linking. Any required processing or data compression is the responsibility of the instrument. Requirements for real-time on-board spacecraft housekeeping data must be identified; such data will only be provided to an experiment if essential for instrument operations.

Housekeeping data will be collected as appropriate and the spacecraft will perform monitoring of these data for fault protection. For example, one bit in the packet will be designated as a request by the instrument for the spacecraft to turn off its power. Other than this monitoring, the instruments must not depend on the spacecraft to perform processing of housekeeping data. Each instrument must include housekeeping data in its own science packets if needed for science evaluation.

Mechanical Interfaces

The SDO instruments will be mounted on the Sun-facing side of the spacecraft bus. During Phase A, detailed design studies will determine whether instruments mount directly to the bus or to an intermediate "instrument module" structure. Nominal volume for the entire instrument payload is expected to be 1.5 meters long (in the Sun-pointing direction) by 1.3 meters square. Proposed suites of instruments should be self-contained and provide their own interfacing structure consistent with the resource allocations in Table 5-1.

The first vibration mode of each instrument shall be maximized to avoid coupling with spacecraft modes. To support the launch vehicle coupled loads analysis, each PI shall provide a reduced structural math model to the spacecraft supplier. Later in the program, the PI shall also supply a physical structural/thermal model (STM) to be used to manufacture the flight harness, perform fit checks, and verify the observatory structural and thermal math models.

Thermal Interfaces

The instrument structure will be actively controlled to near room temperature to ensure thermal stability. Detailed thermal analysis will be required to determine the nominal interface temperature and stability; however, it is expected that during normal operations the temperatures should be stable to $\pm 0.5^{\circ}\text{C}$. During and slightly after the biannual eclipses, additional heater power will be applied to the instrument interface structure to maintain the nominal temperature. As a result, the thermal gradient pattern across the interface will change. The recovery time needed to achieve normal pointing operations will be determined in Phase A. Efforts will be made to keep the lost precision observation time to a minimum by giving careful attention to thermal time constants, the use of multiple zone heating, selection of coatings, and the use of multilayer insulation and high conductance and low coefficient of thermal expansion materials.

It is highly desirable for each instrument to be thermally isolated from the spacecraft. Any requirement for thermal coupling to the spacecraft or access to radiators outside of the instrument payload envelope must be fully described in the proposal to this AO.

During Phase A, the PI team must provide preliminary thermal analysis and modeling for their instrument. In Phases B/C/D, the PI must provide detailed analysis and modeling, as well as a reduced thermal model for the purpose of generating an integrated observatory model. The PI-supplied STM will also be used in validating the analytical thermal model of the observatory.

5.1.4 Mission Operations Support

The SDO Mission Operations Center (MOC) will be designed to support observatory integration and testing, launch preparation, early orbit checkout, and in-orbit operations during the entire mission life. The MOC has responsibility for the control, commanding, telemetry download distribution, and health and safety checkout of the SDO spacecraft. The ground station receives and processes the SDO downlink telemetry and distributes the instrument telemetry to the appropriate locations for further processing.

In the baseline plan, the SDO spacecraft will have continuous telemetry contact with a dedicated ground station. During contact with the ground station, the SDO spacecraft will downlink real-time high rate instrument data as well as spacecraft housekeeping data. The MOC will be staffed eight hours per day, five days per week, after on-orbit checkout, and will be unstaffed at all other times except for emergencies. Instrument commands will be received by the MOC, which will manage the spacecraft and instrument uplink loads for transmission to the spacecraft. Commanding will occur during weekday day shift operations with staff present. The mission is being designed to implement autonomous operations, such as unattended spacecraft contacts and the use of automated paging to allow proper response to spacecraft anomalies. However, the MOC will be capable of supporting unscheduled contacts to mitigate spacecraft emergencies.

Each PI must provide a Science Operations Capability (SOC) in the manner and location deemed best. The SOC, funded by the PI investigation, must be able to take data from the ground station, plan scientific observations, generate instrument command timelines, and perform science data analyses. The SOC is also solely responsible for the health and safety of the PI's instrument. PI's will provide training materials for the flight operations team and all required personnel, hardware, and software for instrument science operations. Proposers are reminded to include the cost of instrument health and safety oversight during the mission phase. Details of the SDO science operations will be defined by the selected science teams.

5.1.5 Project Schedule

The SDO mission is expected to be launched in August 2007. Based on the current implementation plan, which is subject to revision during Phase A, the instruments will be required by June 2006 for integration and integrated testing. Proposals must clearly identify sufficient reserves (both schedule and financial) to ensure on time delivery of the instruments. The Project Schedule, as currently established, is summarized in Table 5-4.

Table 5-4: Project Schedule with Milestones

Phase A	September 2002–May 2003
Initial Confirmation Review	May 2003
Phase B	May 2003–December 2003
Confirmation Review	December 2003
Phase C/D	December 2003–September 2007
Flight Instrument Delivery	June 2006
Launch	August 2007
Phase E	September 2007–August 2013

5.2 Technical Approach and Management Requirements

5.2.1 *General Considerations*

Investigations must encompass all technical aspects from the initial studies, through data collection and analysis, and final delivery of the data to the appropriate NASA data archive, as well as planning and implementation of an appropriate E/PO program. The NASA Policies and Guidelines document, NPG 7120.5A *NASA Program and Project Management Processes and Requirements*, delineates activities, milestones, and products typically associated with each of these phases and may be used as a reference in defining a team's approach. This document is included in the SDO Library (see Appendix C). Investigation teams shall abide by all necessary Federal (including NASA), state, and local laws and regulations.

NASA intends to allow the Principal Investigator and his/her team to use their own management processes, procedures, and methods to the fullest extent practical and the use of innovative processes is encouraged when cost, schedule, technical improvements, and reliability can be demonstrated. Investigation teams should define the management approach best suited for their particular teaming arrangement, including the E/PO program, which should be commensurate with the investigation's implementation approach, while retaining a simple and effective management structure necessary to assure the adequate control of development within the cost and schedule constraints.

In the proposal, the investigation team must present a Work Breakdown Structure (WBS) as described in Appendix B, Section F.

5.2.2 *Leadership of Investigation*

SDO investigation teams must be led by a single Principal Investigator (PI) who is responsible for managing his/her selected investigation and interfacing with the NASA Goddard Space Flight Center (GSFC) Project Office through the Instrument Manager assigned to the investigation and through the SDO Project Scientist. If multiple instruments are proposed as a suite within a single investigation, one PI must be the single point of contact with management responsibilities for the combined effort. The PI is accountable to NASA for the scientific success of the investigation. The PI is in

charge of his/her investigation, with full responsibility not only for its scientific integrity, but its implementation as well, from development of the proposal through all phases of the investigation, including the E/PO program.

Each selected investigation must have a professional Project Manager (PM) who will oversee the technical implementation of the investigation. The role, qualifications, and experience of the PM should be adequate to ensure that the technical and managerial needs of the investigation will be met. If for some extraordinary reason the PM cannot be named in the proposal, the proposers need to have a discussion of when and how an appropriately experienced PM will be selected.

5.2.3 *Risk Management and Quality Assurance*

Each investigation must define the risk management approach it intends to use to ensure successful achievement of its objectives within established resource, funding, and schedule constraints (see Sections E and F of Appendix B). Included in this discussion of risk management should be risk mitigation plans for any new technologies and the need for any long-lead items that need to be placed on a contract before the start of the development phase, in order to ensure timely delivery. In addition, any manufacturing, test, or other facilities needed to ensure successful completion of the proposed investigation should be identified. The proposer must describe the approach for managing risk that will mitigate loss of the mission or serious degradation due to errors by human operators or errors or malfunctions in the mission data systems during the flight phase.

Selected investigations shall have a safety and mission assurance program that is consistent with the requirements of the ISO 9000 series, American National Standard, *Quality Systems - Model for Quality Assurance in Design, Development, Production, Installation, and Servicing*, ANSI/ASQC Q9001- 2000. The investigation's safety and mission assurance program must also meet the requirements in the *LWS Mission Assurance Requirements* (MAR) document, available in the SDO Library (see Appendix C). The LWS MAR will become part of the contractual requirements for selected missions. The MAR defines specific products and processes required during the design and development phases of the investigation. Proposers should note that the LWS MAR requires a Grade 2 parts program and generate instrument cost proposals accordingly. Investigation teams must provide for the impact of these requirements when developing proposed costs.

5.2.4 *Required Project Reviews and Meetings*

The following is a list of technical and management reviews that proposers must include in their schedule development. Additional information pertaining to these reviews can be located in the SDO Library (see Appendix C) in the *LWS MAR* document. Additional reviews may be scheduled during the life of the project:

- Systems Requirements Review
- Initial Confirmation Review

- Preliminary Design Review
- Confirmation Review/Non-Advocate Review
- Critical Design Review
- PreEnvironmental Review
- PreShip Review
- Mission Readiness Review
- Flight Readiness Review
- Launch Readiness Review
- Flight Operations Review
- Mission Operations Review

Principal Investigators will be expected to support the SDO mission by participating in all scheduled NASA/GSFC/SDO programmatic and technical meetings as appropriate; therefore, proposals to this AO need to allow for necessary travel costs. Weekly project-level teleconferences will also be conducted by the GSFC Project Office to exchange technical data regarding the mission requirements, risk and schedule status, and spacecraft-to-instrument interfaces. In addition, the GSFC Project Office will conduct weekly telephone calls with each PI to ensure details and issues specific to each investigation are reviewed. Reviews of the planning and implementation of the E/PO program will be included as an integral element of major management reviews.

5.2.5 Science Working Group

A Science Working Group (SWG) will be established in Phase A composed of the PI's of the instrument investigations. The SWG will be chaired by the SDO Project Scientist who shall be a member of the NASA Goddard Space Flight Center. If an investigation includes a suite of instruments, a Lead Scientist for each of the separate instruments may also participate in the SWG meetings, as may the Project Manager for each entire investigation. However, in the case of any votes that may be taken, each investigation has only one vote, to be cast by the PI. Voting members of the SWG will also include several LWS SDO Mission Scientists, who will be competitively selected after the SDO instrument complement is known. The purpose of the SWG will be to maximize the scientific return of this mission within the existing resources. SWG meetings will be conducted at least twice a year. Proposers should include funding to cover travel for reviews and meetings.

5.3 International Participation

5.3.1 Statements of General Policy

Recognizing the potential scientific, technical, and financial benefits offered to all partners by international cooperation, participation by non-U.S. individuals and organizations as team members in SDO investigations is encouraged on the basis of no exchange of funds. Participation may include, but is not limited to, the contribution of scientific instrument investigations and the subsequent sharing of the data from the mission. However, since such participation can add to management complexity and, therefore, risk, any proposed cooperative arrangements should offer significant benefits

while maintaining clear technical and management interfaces. The proposal should discuss risks and benefits of proposed cooperative arrangements as well as management approaches to mitigating these risks.

Any proposal that includes international participation must provide sufficient cost, schedule, and management data in the proposal and in subsequent reviews to allow evaluation. Proposers are expected to adequately document cost and schedule data, management approaches and techniques, and to document the commitment of all team partners to those costs and schedules in order to lend credibility to the proposal; otherwise, a proposal may be judged unacceptable.

Proposers are advised that a contract or subcontract by a U.S. team with a non-U.S. participant using funds derived from NASA must meet all applicable NASA and Federal regulations. Proposers are further advised that these regulations will place additional requirements on investigation teams that must be explicitly included in discussions of the investigation's cost, schedule, and risk management.

5.3.2 Proposal Preparation and Submission

Proposals must be submitted in English and comply with all submission requirements stated in the AO. All non-U.S. proposals will undergo the same evaluation and selection process as those originating in the U.S. and must be received before the established closing date. Proposals from non-U.S. entities and proposals from U.S. entities that include non-U.S. participation must include a detailed cost plan for the U.S. entities, and, at a minimum, the integrated value of the contribution from each non-U.S. entity (see Section 5.3.1).

5.3.3 Required Endorsement(s)

Participation by non-U.S. individuals and/or institutions as team members or contributors to SDO investigations must be endorsed by their own institutions. If government support is also required, then a government endorsement is also needed. The letter(s) of endorsement must provide evidence that the non-U.S. institution and/or government officials are aware and supportive of the proposed investigation and will pursue funding for their share of the proposed investigation if selected by NASA. Ordinarily endorsements must be submitted per the schedule in Section 8. However, in exceptional cases, proposals containing a foreign component may be considered if for good reason an endorsement cannot be obtained before this deadline. In such cases, the proposal should indicate when a decision on endorsement can be expected; however, NASA reserves the right to reject the proposal without further review should that date be seen as not advantageous to the Government.

5.3.4 Compliance with U.S. Export Laws and Regulations

Proposers, including universities, should be aware that investigations that include international participation, either through involvement of non-U.S. nationals and/or involvement of non-U.S. entities, must include in their proposal a section discussing compliance with U.S. export laws and regulations, in particular, 22 CFR 120-130, *et seq.*

and 15 CFR 730-774, *et seq.*, as applicable to the scenario surrounding the particular international participation (see Appendix B, Sections G.7 and G.8).

Local NASA export control officials may be available to assist successful proposers, after selection, in addressing specific export control issues, consistent with export control laws and regulations pertaining to U.S. Government agencies.

5.3.5 *Nature of Collaborative Agreements with NASA*

When a non-U.S. proposal or a U.S. proposal with non-U.S. participation is selected, a formal international agreement will be established to document the participation. This agreement will provide for no exchange of funds; that is NASA and the foreign sponsor will each bear the cost of discharging their respective responsibilities.

It is the policy of NASA to establish formal international agreements with foreign partners in cooperation on flight missions. For major contributions such as the provision of an entire instrument investigation, either by a foreign partner to a U.S. program or by a NASA-funded party to a foreign-led program, these agreements will be either an intergovernmental memorandum of understanding (MOU) or an implementing agreement under an intergovernmental framework agreement (referred to sometimes as "umbrella agreements").

For less significant exchanges, such as hardware subcomponents or expertise for data analysis, the agreement for the entire cooperation may take the form of an interagency letter of agreement (LOA). For major exchanges that will eventually be covered by an MOU or implementing agreement, it may be necessary to establish an interim LOA that will remain in force until later entry into force of the MOU or implementing agreement. A common example of the latter situation would be a study phase award that entails only a minor U.S. Government financial commitment but requires the legal and/or export control framework provided by a formal international agreement. For those cooperative contributions that will require execution of an LOA for either reason, the sponsoring foreign entity's letter of endorsement to support (if selected) the proposed foreign contribution must contain either (1) a clear statement that the sponsoring foreign entity is legally empowered to bind its own national government, or (2) advance agreement that any LOA's required will be governed by U.S. law.

In the event that a non-U.S. proposal is selected, NASA will contract with a U.S. lead entity for performance of the U.S.-funded elements of the investigation.

5.4 SDO-Related Missions of Opportunity

5.4.1 *General Policies*

An SDO-related Mission of Opportunity (MO) is defined as a proposal for a U.S. proposer to carry out a critical SDO-related investigation by participating in a mission not sponsored by the NASA Office of Space Science that is planned or that has been approved by its sponsoring organization (this includes missions planned by program offices of NASA other than OSS). In such a case, the NASA SDO program may select

and fund that MO investigation if it is clear (i) that the investigation could be regarded as part of the SDO mission as defined in Section 2 of this AO, or that it could otherwise significantly augment the SDO mission objectives as judged by peer review and the NASA LWS staff, and (ii) that its support by NASA would be advantageous to the SDO project.

5.4.2 MO Proposer and NASA Roles and Responsibilities

The participation in an SDO-related MO could take many forms, for example, providing a complete science investigation, providing hardware components of a science instrument, or providing expertise in critical areas of the mission. In any case, NASA will evaluate only the proposed SDO MO investigation and not the sponsor's entire mission, which may have entirely different objectives. While the investigator is not required to document the entire mission of the sponsor, the U.S. investigator must fully document their complete SDO-related investigation in the proposal. In addition, sufficient information about the candidate Mission of Opportunity must be provided to enable NASA to assess the performance, schedule, and cost risk associated with the mission.

Note that selection by NASA through this AO does not constitute selection of the investigation as part of the MO mission itself, which is necessarily a decision made by the sponsor of that mission. Instead, the selection of an SDO-related MO through this AO is a commitment by NASA to fund only the U.S. portion of the investigation as part of the SDO program (and thus within the SDO cost cap), although funding beyond basic studies does not begin until detailed design of the mission itself is underway. If a MO investigation is selected both by NASA and by the mission sponsor, the PI will be responsible to NASA for the scientific integrity and the management of the PI's contribution to the mission.

5.4.3 MO Proposal Review, Selection, and Management

A Mission of Opportunity investigation that is submitted under this AO will be subject to the same selection and review process and will require commitment by the PI for the same cost, schedule (subject to negotiations), and scientific performance as an investigation selected under the NASA-provided spacecraft option. In addition, in keeping with OSS policy, proposals for a Mission of Opportunity to this AO must also include an Education/Public Outreach element (see Section 5.6.1 and Appendix E for details).

It is incumbent on the proposing investigator to provide evidence in their proposal that the sponsoring organization intends to fund the mission and state when the endorsement of NASA for U.S. participation is required. The launch date or date(s) must be no later than six months after the launch of SDO. The operational phase of a Mission of Opportunity must include a reasonable and meaningful overlap with the planned SDO baseline mission operation phase.

If selected, an SDO-related Mission of Opportunity will be conducted on a no-exchange-of-funds basis between NASA OSS and the mission sponsor, including other parts of

NASA. Like other investigations proposed to this AO, the NASA funding is subject to cancellation if there is a cost overrun charged to NASA for any reason, including a launch delay caused by the non-NASA OSS partner. The PI assumes all risk for delays in the mission and must propose appropriate reserves (see specific cost information required for proposals in Appendix B).

Confirmation Reviews for any selected MO's will be held prior to the start of Phase B and Phase C/D. Assuming a positive outcome, NASA will confirm the investigation to proceed to the next Phase. MO investigation teams may have data analysis responsibilities defined by the policies of the mission sponsor; nevertheless, as a condition for confirmation, NASA expects that the mission sponsor will enter into an agreement with NASA to assure that data returned from at least those aspects of the mission in which NASA support is involved, if not the entire mission, will be made available to the U.S. scientific community in conformance with the SDO data policies (see Section 5.5).

5.5 SDO Data Policy

The LWS program seeks to provide data to a broad community of users that will combine the different data sets from SDO and eventually other LWS missions to obtain a better understanding of Sun-Earth interactions. The data will be treated as a public resource and will be made available for public access as soon as is practical. With that in mind, the following principles will guide the development of the final data policy:

- (1) In accordance with the tradition of solar physics for open data and software, starting after the initial check out and calibration period of approximately three months, the research quality data and any specialized software required for its basic analysis will be made available by the investigators to the international community through a project-designated web site with no more than a two month delay from the time of its acquisition (in the case of data) or the completion and verification for its use (in the case of software). Once the calibrated SDO data are deposited in an accessible data bank, NASA intends to provide support for extended data analysis through an SDO Guest Investigator (GI) program.
- (2) SDO space weather quality data products useful for forecasting and monitoring shall be identified in the proposals. The SDO SWG will finalize a list of products that the investigators will be responsible to make publicly available within minutes after receipt of SDO data by the PI teams.
- (3) During Phases A and B, NASA and the PI teams working in the context of the SDO SWG will decide on uniform format(s) for data and standards for analysis software. They will also decide on the location(s) of data analysis and archiving center(s).
- (4) The SDO MOC will retain downlinked raw data for only 30 days during Phase E. Each PI Team is responsible for collecting their raw data from the MOC, providing access to their calibrated data and required software during the mission, and for

maintaining a safe repository for the data until the data and required software are delivered to the end-of-mission archive.

Proposers must identify how they plan to satisfy these policies from the standpoint of hardware, software, personnel, and cost.

5.6 Education and Public Outreach, Advanced Technology, Small Disadvantaged Business Requirements, and Minority Institution Requirements

5.6.1 *Education and Public Outreach (E/PO)*

The Office of Space Science (OSS) expects education and public outreach to be a significant part of each OSS flight program and research discipline, and strongly encourages space science researchers to engage actively in education and public outreach as an important component of their NASA-supported professional activities. In order to achieve this goal, OSS has developed a comprehensive approach for making education at K-14 education levels, as well as the enhancement of public understanding of space science, integral parts of all of its missions and research programs. The key documents (see Appendix E) that establish the basic policies and guide all OSS education and outreach activities are referenced in Appendix C and can be accessed through the SDO Library.

Beyond this general mandate, the comprehensive study of solar variability and its effects on the space and Earth environments through a series of missions that are part of the Living With a Star program is expected to provide a singular opportunity to both engage the public and to work with the formal education system to improve the teaching of science, mathematics, and technology in the United States. Therefore, E/PO will be an integral, required element of the Living With a Star program in general and SDO in particular. In accord with established OSS policies, 1-2 percent of the total LWS Program budget will be allocated to E/PO, and all selected NASA-funded scientific participants in the LWS Program will be required to become actively involved in planning and implementing E/PO efforts as described below:

- PI instrument investigations are required to include an E/PO component as a part of their overall proposals. OSS expects that a substantive education and outreach program will be an integral element of the investigation and that proposers will devote adequate resources to the planning and implementation of such an effort. A general funding guideline of 1-2% of the total investigation budget should apply to the E/PO component of each PI instrument investigation. Therefore, proposals must include the Principal Investigator's approach for planning an education/outreach program, arranging for appropriate partners and alliances, implementing the education/outreach program (including appropriate evaluation activities), and plans for disseminating education/outreach products and materials. Note that this AO's goal for the involvement of small disadvantaged businesses and minority institutions may be met through an appropriately planned E/PO program (see Section 5.6.3). Also note that the funding guideline is intended to apply to the investigation as a whole (throughout all phases of the mission) and not necessarily to each individual year. Within the total funding envelope, year-to-year E/PO expenditures should be

phased to optimize the output of the planned E/PO program over the life of the mission.

- Active involvement by selected, NASA-funded instrument teams will be expected in the overarching LWS Program E/PO program being planned and carried out through GSFC, in addition to their individual E/PO programs (see Appendices C and E). Several steps will be taken after selection to define and enable active participation in one common program and to coordinate and integrate unique instrument investigator E/PO programs into the overall program. E/PO programs being carried out by individual investigations will be coordinated with each other and integrated with the overall LWS E/PO program through a variety of collaborative processes designed to produce one overall E/PO Plan that will meet NASA's and OSS's education and outreach goals and objectives. Budgets of PI instrument investigations should include provisions for participation in such activities (e.g., the allocation of time by key team members for E/PO activities).

Specific instructions for including E/PO efforts in SDO investigation proposals can be found in Appendix B, while other important information concerning the expected content of E/PO elements of proposals, the evaluation criteria to be used to rate E/PO efforts, and assistance available from the OSS Education/Outreach Support Network can be found in Appendix E. The E/PO components of PI instrument investigation proposals will be evaluated by appropriately qualified scientific, education, and outreach personnel. As indicated in Section 7.2, E/PO will not be considered as part of the Categorization process, but will be considered as one of the other factors in evaluating the merits of closely competing proposals in all subsequent stages of the selection and confirmation process.

5.6.2 *Advanced Technology*

NASA seeks to infuse new technologies into its programs and to strengthen the mechanisms by which it transfers such technologies to the U.S. private sector, including the nonaerospace sector. The means by which NASA OSS plans to implement new technology is described in *The Space Science Enterprise Integrated Technology Strategy* (October 1998), which is included in the SDO Library (see Appendix C). SDO investigations represent an opportunity for NASA to develop and test new technologies and applications that enhance the investigation's science return and/or reduce its cost. Investigations dependent on new technology will not be penalized for risk provided that adequate plans are described to provide a reasonable backup approach that will assure the success of the investigation. Instructions for the advanced technology component of the proposal are contained in Appendix B.

5.6.3 *Small Disadvantaged Businesses and Minority Institutions*

The PI and team members shall agree to use their best efforts to assist NASA in achieving its goal for the participation of small disadvantaged businesses (SDB's),

women-owned small businesses (WOSB's), Historically Black Colleges and Universities (HBCU's), and other Minority Educational Institutions (MEI's) in NASA procurements. Investment in these organizations reflects NASA's commitment to increase the participation of minority concerns in the aerospace community and is to be viewed as an investment in our future. Note that the substantial involvement of minority colleges and universities in space science missions and research programs is also a key objective of the OSS E/PO program. Offerors, other than small business concerns, are also advised that contracts resulting from this AO will be required to contain a subcontracting plan that includes goals for subcontracting with small, small disadvantaged, hubzone, veteran-owned, and women-owned small business concerns (see Appendix A, Section XIII).

6.0 PROPOSAL SUBMISSION INFORMATION

6.1 Resources for Additional Information

The SDO Library provides reference documents and background information on the SDO Mission, including science goals, technology and education/public outreach strategies, and information on management aspects of flight programs. The contents of the SDO Library are listed in Appendix C. The online version of the library is at <http://sdo.larc.nasa.gov/SDOLibrary>

All inquiries regarding this AO should be directed to the SDO Program Scientist, as designated below. Inquiries are preferred in writing and may be sent by fax or E-mail; the character string "SDO AO" (without quotes) should be included in the Subject line of all transmissions.

Dr. William Wagner
Sun-Earth Connection Division
Code SS
Office of Space Science
NASA Headquarters
Washington, DC 20546-0001

Telephone: 202-358-0911
Fax: 202-358-3987
E-mail: william.wagner@hq.nasa.gov

Any updates to information during this AO solicitation process will be made available at the WWW location where this AO is posted (see Section 5.1), including answers to questions submitted by proposers to the Program Scientist as discussed above. The author(s) of such questions will not be identified.

6.2 Preproposal Activities

6.2.1. *Preproposal Conference*

A Preproposal Conference will be held in the Washington, DC, metropolitan area in accordance with the schedule in Section 8. Further information, including logistics, will be available at the WWW location where this AO is posted prior to the Preproposal Conference. Participants are to attend at their own expense and to make their own travel arrangements. The purpose of the conference will be to address questions about the proposal process for this AO, including a discussion of the evaluation criteria, procurement approach, International Trade Regulations, and Education and Public Outreach plans. The Preproposal Conference will also answer those questions that are received by NASA at least one week prior to the Preproposal Conference. Questions should be addressed to the SDO Program Scientist at the address in Section 6.1. Additional questions submitted after this date, including those provided in writing at the Conference, may be addressed at the Conference only as time permits. Anonymity of the authors of all questions will be preserved. An SDO AO Preproposal Conference Transcript, including answers to all questions addressed at the conference, will be prepared and posted as part of the SDO Library approximately two weeks after the Conference.

6.2.2. *Notice of Intent to Propose*

A Notice of Intent (NOI) to propose should be submitted by each prospective Principal Investigator on or before the deadline given in Section 8. An NOI is not required but is strongly encouraged by NASA in order to assist in the planning of the evaluation of proposals. The NOI requests information, to the extent known, on the objectives of the proposed investigation, including E/PO, and a description of the instrumentation to be proposed. The NOI should also include the names, addresses, telephone numbers, and E-mail addresses of all prospective team members and their sponsoring organizations. It must be emphasized that SDO is a cost-capped mission. Hence, science team size must be minimized as much as practical (see Appendix B, Section C). All material provided to NASA through an NOI is for information only and is not binding on the submitter. An NOI to propose should be submitted via the Internet at <http://props.oss.hq.nasa.gov/>. Any problems submitting the NOI should be referred to Ms. Debra Tripp at E-mail: dtripp@hq.nasa.gov; phone: 202-479-9030. Do not send a duplicate NOI by postal mail.

6.3 Format, Content, Certifications, and Submission of Proposals

General NASA guidance for proposals is given in Appendix A of this AO, which is considered binding unless specifically amended in this AO. A uniform proposal format is required from all proposers to aid in proposal evaluation. The required proposal format and contents are given in Appendix B; failure to follow these instructions may result in reduced ratings during the evaluation process or, in extreme cases, could lead to rejection of the proposal without review.

All proposals must have a *Cover Page/Proposal Summary* that is to be submitted electronically using the Web site specified in Appendix B. Once the final version of this form is submitted, it must be printed and used to obtain the required original signatures of the Principal Investigator and of an official of the PI's institution authorized to certify institutional support and sponsorship of the investigation, as well as the management and financial portions of the proposal. The proposal shall also include letters of endorsement

signed by an institutional official from every identified partner and organization expecting to provide critical, no-exchange-of-funds contributions of hardware, software, facilities, services (including Co-Investigator or E/PO services), etc., as evidence that the institution and/or government officials are aware and supportive of the investigation and will pursue funding if selected by NASA; this requirement for letters of endorsement also includes any institutions involved in the proposed E/PO effort. Paper copies of proposals and the original, signed version must be received by the due dates specified in Section 8 of this AO.

If a letter of endorsement from a partnering non-U.S. organization cannot be submitted with the original proposal, it may be delivered by the schedule in Section 8 to the address below. In such a case, it should clearly identify the proposal to which it applies.

Note that the authorizing institutional signature on the printout of the electronically submitted Cover Page now also certifies that the proposing institution has read and is in compliance with the three required certifications printed in full in Appendix D. Therefore, it is not necessary to separately submit these certifications with the proposal.

Proposers must provide 40 copies of their proposal, plus the original signed proposal to the following address by 4:30 p.m. EST on the proposal deadline date given in Section 8:

Solar Dynamics Observatory (SDO) Support Office
NASA Peer Review Services
Suite 200
500 E Street, SW
Washington, DC 20024

Point of contact for commercial delivery: Ms. Debra Tripp
Phone: 202 479-9030
Fax: 202 479-9236

All proposals received after the closing date will be treated in accordance with NASA's provisions for late proposals (Appendix A, Section VII).

NASA will notify the proposers in writing or E-mail that their proposals have been received. Proposers not receiving this confirmation within ten days after submittal of their proposals should contact the SDO Program Scientist at the address given in Section 6.1.

7.0 PROPOSAL EVALUATION, SELECTION, AND IMPLEMENTATION

7.1 Evaluation Criteria, Factors, and Procedures

The fundamental aim of this NASA investigation acquisition process is to identify scientific ideas and unique instrumental capabilities that together optimally address the overall scientific objectives of the SDO mission in the context of the LWS program as described in this AO. Proposers should describe how they will coordinate their investigations with other SDO investigations and how their data will effectively contribute to achievement of broader LWS goals. All proposals submitted in response to this AO will be subjected to a preliminary screening to determine their compliance to the constraints, requirements, and guidelines of the AO. Proposals not in compliance may be returned to the proposer without further review. The following Evaluation Criteria are of roughly equal importance and will be used in evaluating the scientific and technical merits of compliant proposals submitted in response to this AO:

- 1) The scientific merit of the proposed investigation, its relevance to the specific opportunity described in this AO, and its perceived value considering the mission resources required.
- 2) The technical merit and feasibility of the proposed investigation, with particular regard to its capability to supply the data needed to successfully achieve the goals of the proposed investigation and to contribute to the success of the SDO project and the LWS program. This factor will also include an evaluation of the competence and relevant experience of the proposing investigation team as an indication of its ability to carry the investigation to a successful conclusion.

For each proposal, the scientific and technical merits (Evaluation Criteria 1 and 2) will be assessed by a panel composed of scientific and technical peers of the proposers. These panels may be augmented by the solicitation of mail-in reviews as well, which the panels have the option to accept, modify, or reject. NASA will use a non-Government organization to provide assistance in organizing and documenting this panel review process. These evaluations will be expressed in terms of the perceived strengths and weaknesses of each proposal. This Peer Review panel will not directly compare proposals.

In the case of investigations that propose to provide suites of instruments, the scientific and technical merit of each instrument will be evaluated. Therefore, proposers must indicate the scientific return and cost of their baseline instrument and the additional scientific return and additional cost for each additional instrument in a suite. Similarly, the additional cost and scientific return should be indicated for capabilities of individual instruments that may exceed the minimum required to meet the objectives of the AO.

Concurrent with the scientific and technical review described above, NASA will convene another panel to evaluate proposals for Technical, Management, Cost and Other (TMCO) merits using the Additional Evaluation Factors defined below.

- The fit of the investigation within the total SDO spacecraft resource and operations constraints identified in Section 5.1 of this AO.
- The proposed total cost to NASA together with management practices, technical and cost risks, and cost realism and reasonableness associated with the proposed investigation. Total NASA cost will be considered to include not only that proposed for instrument development and for data analysis, but the projected cost of the investigation during mission operations (through Phase E). Management aspects include the capability to deliver any proposed hardware on the schedule required by the SDO project.
- The plans for education, outreach, technology, small disadvantaged business, and Minority Institution activities as described in Section 5.6.

Once all evaluations are complete, a panel composed wholly of Civil Service personnel will convene to consider the science Peer Review Panel results and to categorize the proposals on the bases of Evaluation Criteria 1) and 2), in accordance with procedures required by Federal Acquisition Regulations (FAR) Supplement 1870. These Categories are defined below. Note that composite suites, as well as their individual instruments, may be categorized separately in order to give NASA the greatest flexibility in assembling the most scientifically and technically satisfactory and cost-effective payload possible.

- Category I. Well conceived and scientifically and technically sound investigations of high value that are pertinent to the goals of the program and the AO's objectives and offered by a competent investigator from an institution capable of supplying the necessary support to ensure that all essential flight hardware or other support can be delivered on time and that data can be properly reduced, analyzed, interpreted, and published in a reasonable time. Investigations in Category I are recommended for acceptance and normally will be displaced only by other Category I investigations.
- Category II. Well conceived and scientifically or technically sound investigations that are recommended for acceptance, but at a lower priority than Category I.
- Category III. Scientifically or technically sound investigations that require further technical development.
- Category IV. Proposed investigations that are recommended for rejection for the particular opportunity under consideration, whatever the reason.

At this point, the Program Scientist may request a payload accommodation assessment of the highly ranked proposals to aid in developing a recommendation for selection of an integrated science payload that addresses the AO objectives (Section 2).

7.2 Selection Procedures

The results of the proposal evaluations and categorizations and the recommendation for selection of investigations will then be presented by the SDO Program Scientist to the Space Science Steering Committee (SScSC), which is composed wholly of NASA Civil Servants and appointed by the Associate Administrator for Space Science. The SScSC will conduct an independent review of the evaluation and categorization processes regarding both their compliance to established policies and practices, as well as their completeness, self-consistency, and adequacy of all materials related thereto. The SScSC will also review the recommendation for selection in terms of the highest ranked (i.e., Category I and II) proposals and either endorse the recommendation tendered by the Program Scientist or provide a separate one based on their evaluations and deliberations. After this review, the entirety of the evaluation and categorization results (including the reports of the Peer and TMC Review Panels) and the recommendation(s) for selection will be forwarded by the SScSC to the Associate Administrator, who is the Selection Official for this solicitation. The overriding consideration for the final selection of proposals submitted in response to this AO will be to maximize scientific return of the entire mission within the available budget. The three Additional Evaluation Factors identified in Section 7.1 will be invoked at this stage to help discriminate between closely competing proposals (based on their scientific and technical merits) in this final stage of the selection process. The three additional evaluation factors are approximately equal to each other in importance. These three factors combined are less important than either the scientific or technical merit factor. Cost is less important than all other factors combined.

Note that NASA reserves the right to select only a portion of a proposer's investigation and/or to invite his/her participation with other investigators in a joint investigation. In that case, all affected proposers will be given the opportunity to accept or decline such a partial acceptance and/or participation with other investigators (see Appendix A, Section II).

7.3 Implementation Procedures

Following selection, the PI's of the selected investigations will be notified immediately by telephone, followed by formal written notification. The formal notification may include special instructions for the Phase A study. A Project Initiation Conference will be held as soon as possible after selection to clarify requirements and responsibilities of all parties having roles in the mission. Proposers of investigations that were not selected will be notified in writing and offered a debriefing.

Following selection, direct responsibility for establishing contracts with the institutions of the selected Principal Investigators will be assigned to the SDO Project Office at the NASA Goddard Space Flight Center.

Contracts will be awarded for Phase A concept studies, each of which will contain a priced option for a bridge phase that may be exercised upon successful completion of the Initial Confirmation Review (ICR) at the end of Phase A. The bridge phase is intended to cover a three-month period of Phase B effort to provide program continuity while the Phase B/C/D/E negotiations are completed and added to the contract. Model contracts for Phase A and Phases B-E can be found in the SDO Library (Appendix C).

The products of Phase A will be implementation plans (including E/PO) that detail the technical, cost, schedule, and technology readiness levels (TRL) required to complete definition, implementation, and mission operation activities. The SDO Library contains definitions of each TRL. A TRL of at least 6 is required for transition from Phase A to B. NASA may request presentations and/or site visits to review the Phase A implementation plans with the investigation teams. Information from the implementation plans will form the basis for the SDO Mission ICR. If approved at the end of Phase A, NASA expects investigations to proceed toward Confirmation for Implementation by exercising their bridge phase options.

At the completion of Phase B (i.e., after the Preliminary Design Review), an independent review team, chartered by the Associate Administrator for Space Science, will conduct a Confirmation Assessment of the SDO mission, the results of which will be presented to the Associate Administrator in a formal Confirmation Review (CR). The CR constitutes the NASA Procedures and Guidelines (NPG) 7120.5 Approval process. Chapter 7 of the Draft Code S Handbook describes the CR (see Appendix C). GSFC will also hold a Confirmation Readiness Review prior to the CR. The SDO Project Manager, the independent review team chair, and the Chair of the Goddard Program Management Council (GPMC) will present results of these reviews to the Associate Administrator for Space Science at the CR. The Associate Administrator will then decide whether to confirm the mission for implementation (Phase C/D). This decision will be based upon the project's readiness to proceed to design and development and programmatic considerations such as cost, schedule, the ability to achieve the scientific objectives delineated in the proposal, the maturity of the plans for E/PO, and the completeness of the project's level-one requirements. If not confirmed for implementation, the mission may be sent back for more study or may be terminated. Individual investigations may also be descoped or even terminated at this time.

Should a non-U.S. proposal or a U.S. proposal with non-U.S. participation be selected, NASA's Space Science and Aeronautics Division within the Office of External Relations will arrange with the sponsoring non-U.S. agency for the proposed participation on a no-exchange-of-funds basis, in which NASA and the non-U.S. sponsoring agency will each bear the cost of discharging their respective responsibilities. Depending on the nature and extent of the proposed cooperation, these arrangements may entail a letter of notification by NASA with a subsequent exchange of letters between NASA and the sponsoring governmental agency or a formal agency-to-agency Memorandum of Understanding (MOU).

8.0 SCHEDULE

The schedule of events associated with this Announcement of Opportunity is as follows:

- Release AO January 18, 2002
- Preproposal Conference February 1, 2002
- Notice of Intent due (see Section 6.2) February 20, 2002
- Proposal submittal due by 4:30 PM EST April 24, 2002
- Letter(s) of Endorsement for Non-U.S. proposals due May 24, 2002
- Selection of Investigations for Phase A Study (goal) August 2002
- Award of Phase A Study Contracts (goal) September 2002

9.0 CONCLUSION

The SDO mission represents a significant step in accomplishing the goals of NASA's Living With a Star program. NASA invites both the U.S. and international space science communities to participate in proposals for SDO investigations to be carried out as a result of this Announcement.

Edward J. Weiler
Associate Administrator for
Space Science

APPENDIX A

GENERAL INSTRUCTIONS AND PROVISIONS

I. INSTRUMENTATION AND/OR GROUND EQUIPMENT

By submitting a proposal, the investigator and institution agree that NASA has the option to accept all or part of the offeror's plan to provide the instrumentation or ground support equipment required for the investigation or NASA may furnish or obtain such instrumentation or equipment from any other source as determined by the selecting official. In addition, NASA reserves the right to require use, by the selected investigator, of Government instrumentation or property that becomes available, with or without modification, that will meet the investigative objectives.

NOTICE TO ALL OFFERORS: In the event that a Principal Investigator employed by NASA is selected under this AO, NASA will award prime contracts to non-Government participants, including Co-Investigators, hardware fabricators, and service providers who are named members of the proposing team, as long as the selecting official specifically designates the participant(s) in the selection decision. Refer to Section G of Appendix B of this AO for proposal information that the selecting official will review in determining whether to incorporate a non-Government participant in the selection decision. Each NASA contract with hardware fabricators or service providers selected in this manner will be supported by an appropriate justification for other than full and open competition, as necessary.

II. TENTATIVE SELECTIONS, PHASED DEVELOPMENT, PARTIAL SELECTIONS, AND PARTICIPATION WITH OTHERS

By submitting a proposal, the investigator and the organization agree that NASA has the option to make a tentative selection pending a successful feasibility or definition effort. NASA has the option to contract in phases for a proposed experiment and to discontinue the investigative effort at the completion of any phase. The investigator should also understand that NASA may desire to select only a portion of the proposed investigation and/or that NASA may desire the individual's participation with other investigators in a joint investigation, in which case the investigator will be given the opportunity to accept or decline such partial acceptance or participation with other investigators prior to a selection. Where participation with other investigators as a team is agreed to, one of the team members will normally be designated as its team leader or contact point.

III. SELECTION WITHOUT DISCUSSION

The Government reserves the right to reject any or all proposals received in response to this AO when such action shall be considered in the best interest of the Government. Notice is also given of the possibility that any selection may be made without discussion (other than discussions conducted for the purpose of minor clarification). It is, therefore, emphasized that all proposals must be submitted initially on the most favorable terms that the offeror can submit.

IV. NONDOMESTIC PROPOSALS

The guidelines for proposals originating outside of the United States are the same as those for proposals originating within the United States, except that the additional conditions described in Section 5.3 of the AO shall also apply.

V. TREATMENT OF PROPOSAL DATA

It is NASA policy to use information contained in proposals and quotations for evaluation purposes only. While this policy does not require that the proposal or quotation bear a restrictive notice, offerors or quoters should place the following notice on the title page of the proposal or quotation and specify the information subject to the notice by inserting appropriate identification, such as page numbers, in the notice. Information (data) contained in proposals and quotations will be protected to the extent permitted by law, but NASA assumes no liability for use and disclosure of information not made subject to the notice. To prevent inadvertent disclosure, proposal data shall not be included in submissions (e.g. final reports) that are routinely released to the public.

RESTRICTION ON USE AND DISCLOSURE OF PROPOSAL AND QUOTATION INFORMATION (DATA)

The information (data) contained in (insert page numbers or other identification) of this proposal or quotation constitutes a trade secret and/or information that is commercial or financial and confidential or privileged. It is furnished to the Government in confidence with the understanding that it will not, without permission of the offeror, be used or disclosed for other than evaluation purposes; provided, however, that in the event a contract is awarded on the basis of this proposal or quotation, the Government shall have the right to use and disclose this information (data) to the extent provided in the contract. This restriction does not limit the Government's right to use or disclose this information (data) if obtained from another source without restriction.

VI. STATUS OF COST PROPOSALS

Submission of cost or pricing data, as defined in FAR 15.401, is required if the combined Phase A and Bridge Phase costs exceed \$550,000. Cost or pricing data will also be required for proposals for subsequent investigation phases. The investigator's institution agrees that the cost proposal submitted in response to the Announcement is for proposal evaluation and selection purposes, and that, following selection and during negotiations leading to a definitive contract, the institution may be required to resubmit or execute all certifications and representations required by law and regulation.

VII. LATE PROPOSALS

The Government reserves the right to consider proposals or modifications thereof received after the date indicated, should such action be in the interest of the Government.

VIII. SOURCE OF SPACE INVESTIGATIONS

Investigators are advised that candidate investigations for space missions can come from many sources. These sources include those selected through the AO, those generated by NASA in-house research and development, and those derived from contracts and other agreements between NASA and external entities.

IX. DISCLOSURE OF PROPOSALS OUTSIDE GOVERNMENT

NASA may find it necessary to obtain proposal evaluation assistance outside the Government. Where NASA determines it is necessary to disclose a proposal outside the Government for evaluation purposes, arrangements will be made with the evaluator for appropriate handling of the proposal information. Therefore, by submitting a proposal the investigator and institution agree that NASA may have the proposal evaluated outside the Government. If the investigator or institution desires to preclude NASA from using an outside evaluation, the investigator or institution must so indicate on the cover. However, notice is given that if NASA is precluded from using outside evaluation, it may be unable to consider the proposal.

X. EQUAL OPPORTUNITY

For any NASA contract resulting from this solicitation, the clause at FAR 52.222-26, "Equal Opportunity," shall apply.

XI. PATENT RIGHTS

- A. For any contract resulting from this solicitation awarded to other than a small business firm or nonprofit organization, the clause at 1852.227-70, New Technology, shall apply. Such contractors may, in advance of a contract, request waiver of rights as set forth in the provision at 1852.227-71, Requests for Waiver of Rights to Inventions.
- B. For any contract resulting from this solicitation awarded to a small business firm or nonprofit organization, the clause at FAR 52.227-11, Patent Rights—Retention by the Contractor (Short Form) (as modified by 1852.227-11), shall apply.

XII. RIGHTS IN DATA

Any contract resulting from this solicitation will contain the Rights in Data – General Clause: FAR 52.227-14.

XIII. SMALL AND SMALL DISADVANTAGED BUSINESS SUBCONTRACTING

- A. Offerors are advised that, in keeping with Congressionally mandated goals, NASA seeks to place a fair portion of its contract dollars, where feasible, with small disadvantaged business concerns, women-owned small business concerns, Historically Black Colleges and Universities, and minority educational institutions, as these entities are defined in 52.219-8 and in 52.226-2 of the FAR. For this Announcement of Opportunity, the offeror's subcontracting plan will be evaluated on the participation goals and quality and level of work performed by small disadvantaged business concerns, women-owned small business concerns, Historically Black Colleges and Universities, and other minority

educational institutions. Offerors will be evaluated on the participation in the performance of the mission of small disadvantaged business concerns in the authorized Standard Industrial Classification (SIC) Groups as determined by the Department of Commerce (see FAR 19.201 (b)), as well as the participation of women-owned small business concerns, HBCU's and OMI's.

- B. Offerors are advised that for NASA contracts resulting from this solicitation that offer subcontracting possibilities, exceed \$500,000, and are with organizations other than small business concerns, the clause FAR 52.219-9 shall apply. Offerors whose investigations are selected under this AO will be required to negotiate subcontracting plans which include subcontracting goals for small, small disadvantaged, women-owned, veteran-owned, and HUB Zone small business concerns. Note that these specific subcontracting goals differ from the goals described in paragraph A above, and need not be submitted with the proposal. Failure to submit and negotiate a subcontracting plan after selection shall make the offeror ineligible for award of a contract.

APPENDIX B

SPECIFIC GUIDELINES FOR PROPOSAL PREPARATION IN RESPONSE TO THIS AO

The following guidelines apply to the preparation of proposals by potential investigators in response to this SDO Announcement of Opportunity (AO). The guidelines apply to both science investigations to be flown on the SDO spacecraft and SDO-related Missions of Opportunity. The material presented is a guide for the prospective proposer and is not intended to be all encompassing. The proposer must, however, provide information relative to those items applicable or as otherwise required by the Announcement of Opportunity. In the event of an apparent conflict between the guidelines in this Appendix and those contained within the body of the AO, those within the AO shall take precedence.

GENERAL GUIDELINES

All documents must be typewritten in English, use the metric system of units, and be clearly legible. Submission of proposal material by facsimile (fax), electronic media, videotape, floppy disk, etc., is not acceptable, nor may a proposal reference a WWW site for data or information needed to understand or complete the proposal. In evaluating proposals, NASA will only consider printed material.

The proposal must consist of only one volume, with readily identified sections corresponding to sections A through G given below. Proposals shall adhere to the page limits in Table B-1, including no more than two fold-out pages (28 x 43 cm; i.e., 11 x 17 inches) that count as one page each. All pages other than fold-out pages shall be 8.5 x 11 inches or A4 European standard. The cover, table of contents, required cost table(s) and appendices will not be counted against the page limit; for the remainder, every side upon which printing appears will be counted against the page limits.

Single- or double-column format is acceptable. In complying with the page limit, the type font shall not be smaller than 12-point Times (i.e., no more than 15 characters per inch) and 1-inch (2.5 cm) margins shall be used all around. Smaller font is allowed for figures, captions, and in cost tables provided that legibility is preserved.

In order to allow for recycling of proposals after the review process, all proposals and copies must be submitted on plain white paper only (e.g., no cardboard stock or plastic covers, no colored paper, etc.). Proposers are not permitted to use three-ring binders. Photographs and color figures are permitted if printed on recyclable white paper only. The original signed copy (including cover and endorsements) must be bound in a manner that makes it easy to disassemble for reproduction. Except for the original, two-sided copies are preferred.

Table B-1. Proposal Page Guideline

<u>Section</u>	<u>Page Limits</u>
Graphics Cover Page (optional)	1
Cover Page and Proposal Summary	Printout of electronic submission
Table of Contents	1
Science Investigation Description	25, plus 8 pages for each additional instrument if a suite of instruments is proposed, plus 2 pages if proposing to also provide the SDO Guide Telescope
Education/Public Outreach	4, plus related budget pages as required
Technology, and Small, Disadvantaged Business/Minority Institution Plan	2
Mission Operations Support and Data Analysis Plan	4, plus 1 page for each additional instrument if a suite of instruments is proposed
Management, Schedule, Cost Estimating Methodology, Risk Management Plan and Cost Plan	15, plus 3 pages for each additional instrument, plus required cost table(s)
<u>Appendices</u> (No others permitted):	No page limit but small size encouraged
<ul style="list-style-type: none"> • Resumes (2 pages maximum each person) • Statement of Commitment from Each Co-I • Letter(s) of Endorsement from Participating Institution(s) • Statement(s) of Work • References • Description of Team Member Selection (NASA PI's only) • Technical Content of Any International Agreements • Discussion on Compliance with U.S. Export Laws and Regulations 	

The content of each proposal shall be as follows:

A. COVER PAGE AND PROPOSAL SUMMARY

A Cover page and Proposal Summary must be a part of the proposal, but will not be counted against the page limit. It must be signed by the Principal Investigator and an official by title of the investigator's organization who is authorized to commit the organization. This authorizing signature now also certifies that the proposing institution has read and is in compliance with the three required certifications printed in full in Appendix D; these certifications do not need to be submitted separately.

The full names of the Principal Investigator and the authorizing official, their addresses with zip code, telephone and fax numbers, and electronic mail addresses, shall be included on the Cover Page. Additional information, including the names, institutions, and E-mail addresses of all participants, type of instrument(s) proposed, total investigation cost, and a 220-word Proposal Summary (including E/PO) shall also be included.

The Cover Page/Proposal Summary is generated by filling in the form provided for this program at the WWW site located at <http://props.oss.hq.nasa.gov/>. Once the requisite information is supplied, it is submitted electronically to that WWW site and a hard copy is printed in time to acquire signatures for inclusion with the hard copies of the proposal for delivery according to the schedule provided in Section 8 in this AO. Proposers are advised that they must not reformat or correct this Cover after it is printed, as important NASA-required documentation may be lost; amendments to this item are possible up to the time of its final submission by following the directions at this Web site. Proposers without access to the Web or who experience difficulty in using this site may contact Ms. Debra Tripp (E-mail: dtripp@hq.nasa.gov) for assistance. Please note that submission of the electronic Cover does not satisfy the deadline for proposal submission.

It is NASA's intent to enter the Proposal Summaries of all selected investigations for its various programs into a publicly accessible database. Therefore, the Proposal Summary should not contain proprietary or confidential information that the submitter wishes to protect from public disclosure.

An optional graphic cover page may be placed ahead of the copy of the electronically submitted Cover Page. It will not count against the page limit as long as it contains no technical information not found in the body of the proposal.

B. TABLE OF CONTENTS

The proposal must contain a one-page Table of Contents that parallels the outline provided below in Sections C through G.

C. SCIENCE INVESTIGATION

The science section must describe the scientific objectives of the proposed investigation, including the perceived value of the investigation to the SDO mission objectives. A discussion of the scientific products and how the science products and data obtained will be used to fulfill

the scientific objectives must be provided. A discussion of how the science data will be obtained, including a plan for delivery of the products, and the individuals responsible for the data delivery, must also be provided.

1. Scientific Goals and Objectives. This section must consist of a discussion of the goals and objectives of the investigation; their value to NASA's Living With a Star Program and to the specific SDO objectives described in this AO; and their relationships to past, current, and future investigations and missions. It must describe the history and basis for the proposal and discuss the need for such an investigation. The practical applications of the investigation, in relation to space weather forecasting, must also be outlined.

The measurements to be taken in the course of the mission, the data to be returned, and the approach that will be taken in analyzing the data to achieve the scientific objectives of the investigation must be discussed. This description must identify the investigation to be performed, the quality of the data to be returned (resolution, coverage, pointing accuracy, measurement precision, calibration, etc.), and the quantity of data to be returned (bits, images, etc.). The SDO data downlink must support all of the instruments; consequently, proposers must justify their telemetry requirements in terms of the overall mission objectives. The relationship between the data products generated and the scientific objectives must be explicitly described. The improvement over current knowledge that the results of the investigation are expected to provide must be clearly stated.

2. Science Implementation.

- a. Instrumentation. This section must describe the instrumentation and the criteria used for its selection. While it is not expected that full details of instrument design will be available until completion of further studies, the information requested in the following paragraphs is needed for proposal review and, thus, must be provided to the extent known. This section must identify the individual components (including any mechanisms supplied by the proposer) and instrument systems, including their characteristics and requirements. In addition, the proposal must describe how the data that are to be obtained with the proposed hardware may be related to other SDO investigations and the broader goals of SDO. Specific approaches being proposed to maximize the effective use of these data for the study of outstanding problems in solar physics in the context of LWS must be identified together with the proposer's plans for data processing and management.

In particular, the proposal must describe all parameters of the instrument that are pertinent to the accommodation of the instrument within the spacecraft resources and configuration advertised in this AO (and updated at the WWW location where this AO is posted – see Section 5.1) plus any special requirements necessary for successful implementation. This information must be given in sufficient detail to permit an evaluation of both the concept and the practical feasibility of the hardware. These resources include, but are not limited to: volumetric envelope, mass, power and thermal requirements (including preferred thermal limits); telemetry and command requirements; environmental sensitivities (e.g., to electrical cleanliness, magnetic fields, and contamination); any special spacecraft or launch vehicle integration requirements or constraints; pointing requirements; and on-board data processing. Mass, power, and data

processing budgets should be provided. The power discussion must outline average, cruise, and peak power use, and a time profile of power needs.

The instrument-level reserves for resources such as mass, telemetry, and power must also be identified. By way of definition *reserve* is the amount that when added to an estimated quantity results in the maximum expected value for that resource. Percent reserve is the proposed value of the reserve divided by the maximum value of the resource less the reserve. Since the SDO resources must support all of the instruments, proposers must justify their requirements in terms of the overall mission objectives.

The proposal must outline items that are proposed to be developed, as well as any existing instrumentation or design/flight heritage. The heritage of various parts of the instrumentation, supporting systems, and software must be described. For any level of heritage claimed, cost information about the referenced sources of heritage will be required in the section on cost-estimating methodology.

In the case of proposals for multiple instruments, both individual instrument types and package parameters must be detailed to the extent possible. Proposals for multiple instruments are expected to justify each instrument type. Multiple-instrument proposals are expected to provide technical and cost information for each instrument sufficient to allow separate evaluation. This requirement also necessitates estimates of the fraction of shared resources ascribable to each instrument.

A preliminary description of the instrument design with a block diagram showing the instrument systems and their interfaces must be included. In the case of a new or not-yet-space-qualified design, the instrument must, to the extent possible, be compared on the basis of performance, complexity, and cost to existing instruments. Since the locations of the interfaces are not finalized, proposers must identify possible locations for the electrical, mechanical, and data interfaces based on information provided in this AO (and updated at the WWW location where this AO is posted; see Section 5.1). In addition, the preferred location of the instrument itself on the spacecraft must be described. Where more than one choice is available, proposers must identify and justify their preference. Proposals must include a discussion of the purpose of the instrument, data rates (peak and average), fields of view, resolution, sensitivity, pointing accuracy, etc. Instrument testing and calibration (both pre- and during flight) must also be described.

The proposal shall include a flow diagram indicating order of assembly and tests. In addition, the PI shall submit a verification matrix that describes the tests that are to be performed on components, development units, and subassemblies.

- b. Mission. The observing strategy, within the framework of the expected spacecraft performance, required for obtaining the necessary data with the proposed instrumentation must be described. Operational constraints and viewing and pointing requirements must be identified. The concept and the expected requirements for supporting mission operations must be given. Requirements for pre- or postlaunch ground operations support must be identified. Proposers who require Mission Operations Center support beyond what is currently planned must include the cost for the additional MOC support

under Phase E in Table B-2. The planned support for mission operations is described in Section 5.1.4 of the AO.

- c. Data Collection, Analysis, and Archiving. For both SDO investigations and investigations funded as SDO Missions of Opportunity, the data reduction and analysis plan, following delivery of the data to the ground, must be discussed, including the method and format of the data reduction, data validation, and preliminary analysis. The process by which data will be prepared for archiving must be discussed, including a list of the specific data products and the individual team members responsible for the data products. The plan must include a detailed schedule for the submission of raw and reduced data to the appropriate data archive in the proper formats, media, etc. Delivery of the data to the data archive must take place in the shortest time possible as specified by the NASA policy on open data access and Section 5.5 of the AO.
- d. Science Team. This section must identify the investigation science team. It is required that every Co-I's role and responsibilities be explicitly given in the proposal. NASA strongly encourages proposers to identify only the most critically important personnel to aid in the execution of their proposals. (Note: the inclusion of Co-I's who are judged by peer review to have either insignificant or unjustified roles in a proposed program of research will be considered a weakness for purposes of the evaluation of the proposal.) Additionally, the roles and responsibilities of any other science team member funded for the investigation (defined as meaning anytime in Phases A-E) must also be explicitly defined and the capabilities and experience of all Co-I's and funded science team members must be described. The names of all Co-I's and funded science team members must appear on the Cover Page and Proposal Summary. The PI must submit a resume or *Curriculum Vitae* (not to exceed the specified page limit) that includes his/her professional experiences, positions, and a bibliography of publications relevant to the proposal. Resumes or *Curriculum Vitae* of Co-I's and funded science team members must also be included in the appendices (see Section G below).

Statement(s) of Commitment from Co-I's and/or Funded Science Team Members

Every Co-I and funded science team member from a U.S., as well as a non-U.S., institution identified in the proposal must submit a brief, signed statement of commitment that acknowledges his/her participation, even if they are from the PI's own institution. In the case of more than one Co-I and/or funded science team member from a given institution, a single, multiply signed statement is acceptable. Each statement should be addressed to the PI, may be the copy of a facsimile or an electronic mail message with headings that identify the sender as the Co-I in question, and must contain the following, or approximately similar, language:

"I(we) acknowledge that I(we) am(are) identified by name as Co-Investigator(s) [or funded science team member(s)] to the investigation entitled <name of proposal> that is submitted by <name of Principal Investigator> to the <name of Announcement> NASA Research Announcement, and that I(we) intend to carry out all responsibilities identified for me(us) in this proposal. I(we) understand that the extent and justification of my(our) participation as stated in this proposal will be evaluated during peer review in determining the merits of this proposal."

In addition, if that person or his/her institution will be providing or contributing hardware, software, or other tangible services, a letter from that institution must also be included that certifies their intended contribution.

Current and Pending Support

Information must be provided for all ongoing and pending projects and proposals that involve the proposing PI, Co-I's, and funded science team members. Therefore, for each of the two categories of support as may exist at the time of the proposal submission deadline, namely,

- a. Current Support (for any of the period that overlaps with the proposal being submitted to this AO), and/or
- b. Pending Support (including the proposal to this AO),

the proposal must provide the following information for each such individual:

- Title of award or project;
- Program name (if appropriate) and sponsoring agency institution (including point of contact);
- Proposed period of performance and budget; and
- Commitment by PI, Co-I, or funded science team member as a fraction of a full-time Work Year (WY).

D. EDUCATION, OUTREACH, TECHNOLOGY, AND SMALL DISADVANTAGED BUSINESS/MINORITY INSTITUTION PLAN

The Education/Public Outreach, technology, and small disadvantaged business/minority institution sections shall provide a summary of the benefits offered by the investigation beyond the scientific benefits. These sections must be included in the hard copy submission of the proposal, within the page limits outlined in Table B-1.

1. Education and Public Outreach Plan. Plans must be described for Education and Public Outreach activities of the proposed investigation, arrangements for appropriate partners and alliances, implementation of proposed activities, and dissemination of any products and materials. The proposal must also include a statement of intent and plans (budget and personnel) for participation in the umbrella LWS E/PO Program. See Appendix E for further guidance on the content of the E/PO section of the proposal. This section should also include E/PO Budget Summaries as defined in Appendix E, with a single Budget Summary form (see Appendix E) for each year of the proposed effort, a Budget Summary for the total effort and, without page limit, sufficient budget narrative to fully understand the entries and demonstrate how the budget is linked to and supports the proposed program of activities.
2. Technology Plan. The proposal must address the use of new technology in the implementation of the investigation and the transfer of technology beyond NASA and the space science community. Guidance on the use of new technology in investigations can

be found in the Space Science Enterprise Integrated Technology Strategy, which can be accessed through the SDO online library (see Appendix C).

3. Small, Disadvantaged Business/Minority Institution Plan. Plans are required for the proposed investigation's commitment to meet the small disadvantaged business participation goal. See AO Section 5.6.3 and Appendix A, Section XIII.

E. MANAGEMENT AND SCHEDULE

This section must summarize the investigator's proposed management approach, putting it in the context of the work to be accomplished. A Work Breakdown Structure (WBS) must be presented that covers the entire effort of the investigation, including E/PO. The management organization (including an organization chart) and decision-making process must be described and the teaming arrangement (as known) must be discussed. The responsibilities of team members, including contributors, and institutional commitments must be discussed. Unique capabilities that each team member organization brings to the team, as well as previous experience with similar systems and equipment, must be addressed. The specific roles and responsibilities of the key personnel, Principal Investigator, Co-Investigators, and Project Manager, must be discussed. The relationship between the PI, his/her team, the instrument provider(s) (if not the PI), and NASA must be outlined. A Risk Management Plan, including possible descope options with cost-savings indicated, particularly in the case of multi-instrument proposals, must be described.

A Project Schedule to meet the proposed launch date and covering all phases of the investigation must be provided, including the planning and implementation of the E/PO program. The schedule must include proposed review dates, instrument development and delivery, instrument to spacecraft integration and test, any special launch vehicle integration issues, and mission operations and data analysis. Schedule reserve must be clearly identified.

Mission of Opportunity proposals must specifically address how the investigation team will relate with the sponsoring organization, for example:

- The status of the commitment from the host mission's sponsoring organization to fly the proposed SDO instrument or conduct the proposed investigation;
- If and how the proposed SDO investigation relates to the sponsor's overall mission objectives;
- The SDO investigation development plan and how it fits in the development plan for the sponsor's mission; and
- How the operations plan for the proposed SDO investigation fits within those for the mission of the sponsoring organization.

F. COST ESTIMATING METHODOLOGY AND COSTS

The Cost Plan must provide an estimate of the total lifecycle cost to NASA of the investigation, along with sufficient technical information to allow the reliability of the figures to be judged. The assumptions on which the estimate is based must be stated, particularly with regard to any requested Government furnished equipment and services. For purposes of this cost estimate, the proposer should assume delivery of any hardware in accordance with the Project Schedule shown in Table 5-4 of the AO (see Section 5.1.5). Proposal cost estimates must include clearly

identified and sufficient reserves of both schedule and financial resources to ensure on-time delivery.

The Cost Plan must have two parts: detailed total cost for Phase A and the Bridge phase, and an estimated cost plan for Phases B, C, D, and E. Phase A contracts with a bridge option will be issued for the concept study. During the bridge phase, the contract modification for Phase B through E will be negotiated. Proposers must estimate the Total NASA Cost (see Table B-2) in the proposal and, if selected through this AO, in much more detail in the Phase A implementation plans. Total NASA Cost for an investigation is the funding that NASA OSS would be expected to provide to the investigation team over the course of the investigation, beginning with selection and ending with the conclusion of Phase E. Examples of costs to be included are education and outreach activities; new technology; subcontracting costs (including fees); all science team personnel required to conduct the investigation, analyze and publish results, and deliver data in archival format; science operations center and ground data system; labor (contractor); noncontributed NASA Civil Servant costs; reserves; and contract fees. Contributions by foreign partners are not considered to be part of the Total NASA Cost. However, cost estimates for these contributions must be included (see Table B-2) to allow a full assessment of the Total Investigation Cost (Total NASA Cost plus foreign contributions).

Because the interfaces between the instruments and the spacecraft have not been finalized, proposers are asked to break down the estimates to a level that allows the total costs associated with major subsystems of the hardware to be identified. Since cost details for Phase B/C/D/E are not anticipated until the conclusion of Phase A, cost estimates in the proposal may be generated with models or cost estimating relationships from analogous investigations.

An investigation may be required to descope to meet cost or other resource constraints; therefore, the proposer shall identify a prioritized Risk Management Plan for the removal of requirements, such as science objectives, reduction of testing, etc. The E/PO program element should not be considered a descope option. The decision points for achieving effective reductions in cost and schedule must be identified. The hardware and project costs associated with the investigation at each level of descoping must be estimated and any resulting schedule savings must be outlined.

This section shall include a first-order estimated cost of the investigation that encompasses all proposed activities, including Phases A/B/C/D/E, development of the ground system if there are any special requirements needed to support the proposed instrument(s), fee, and contributions. Spacecraft operations costs will be covered by the project, thus proposers need only include costs for science operations, data analysis, and EPO activities in their Phase E estimates. Costs must be consistent with the available resources defined in Section 1.4 of the AO. Since the available funding must support the entire science payload, proposers must justify their costs in terms of the overall mission objectives. The amount to be costed in each fiscal year must be identified by providing the data in Table B-2, which will not be counted against the page limit, using the elements of the proposer's WBS and any other items unique to the proposal. Proposers may define their own WBS; however, a sample WBS is provided in Table B-4. Note that if the proposal includes the Guide Telescope discussed in Section 5.1.2 of the AO, the additional cost to provide the Guide Telescope must be clearly identified, as must any cost savings associated with concomitant instrument simplification. Also, note that the cost of Data Analysis must be shown separately from Science Operations costs. The top portion of Table B-2 requests cost data relative to the NASA Cost. The lower portion addresses both domestic and non-U.S. contributions.

Additionally, a separate Summary of Elements of Cost by fiscal year shall be provided for Phase A and the Bridge Phase. The summaries shall provide data by U.S. Government fiscal year (October 1 – September 30) in real-year (RY) K dollars. A template and instructions for this summary are provided in Table B-3 and the Cost Table Instructions. Cost estimates for contributions should not be included in these summaries. Table B-5 gives the NASA inflation index. These rates should be used to calculate real-year dollars unless an industry forward pricing rate is used and documented.

For an individual instrument proposal, one Table B-2 and one Table B-3 (Phase A and Bridge Phase) are required. For proposals with more than one instrument, one Table B-2 and one Table B-3 is required that shows the total cost for all instruments. In addition, a separate Table B-2 is required for each instrument in the suite. For example, if three instruments are proposed, then there must be 4 versions of Table B-2. One will show the total cost if all instruments are selected as proposed. The other three tables must address the cost of each instrument as if it were selected separately. An explanation should be provided with each Table B-2, for an individual instrument in a suite, noting whether there are any performance changes or design changes if only the single instrument is selected.

The methodology used to estimate the cost, for example, engineering estimate, specific cost model, past performance, and cost estimating relationships from analogous missions, must be discussed. If an estimate is based on heritage, the performance and cost parameters that the proposed system has in common with the previous system shall be provided. No matter which estimation method is used, sufficient details must be provided in this section and in the technical description of the instrument(s) to allow reviewers to verify the estimate. Budget Reserve Strategy, including budget reserve levels as a function of mission phase, and the reserve level as a percentage of the total cost, must be discussed.

Special Considerations for the Cost Section

1. Full Cost Accounting

NASA civil service labor and supporting NASA Center infrastructure must be costed on a full cost accounting basis. If NASA guidance for full cost accounting has not been fully developed by the closing date for proposal submission, NASA Centers may submit full cost proposals based on the instructions in the NASA Financial Management Manual, Section 9091-5, "Cost Principles for Reimbursable Agreements," or based on their own Center-approved full cost accounting models. If any NASA costs are to be considered as contributed costs, the contributed item(s) or service must be separately funded by an effort complementary to the proposed investigation and the funding sources must be identified. Other Federal Government elements of proposals must follow their agency cost accounting standards for full cost. If no standards are in effect, the proposers must then follow the Managerial Cost Accounting Standards for the Federal Government as recommended by the Federal Accounting Standards Advisory Board.

2. Goods and/or Services Offered on a No-Exchange-of-Funds Basis

Contributions of any kind, whether cash or noncash (property and services), to SDO investigations by organizations other than the NASA Office of Space Science are welcome. The value of the contributed goods and or services must be entered in the lower part of

Table B-2. Values for all contributions of property and services shall be established in accordance with applicable cost principles. Such contributions may be applied to any part or parts of an investigation. For contributions from U.S. organizations a letter of endorsement that provides evidence that the institution and/or appropriate U.S. Government officials are aware and supportive of the proposed contributions to the investigation and will pursue funding if selected by NASA must be submitted with the proposal. For contributions from non-U.S. organizations, see item 3 below.

The cost of contributed hardware or software should be estimated as either: (1) the cost associated with the development and production of the item if this is the first time the item has been developed and if the mission represents the primary application for which the item was developed; or (2) the cost associated with the reproduction and modification of the item (i.e., any recurring and mission-unique costs) if this is not a first-time development. If an item is being developed primarily for an application other than the one in which it will be used in the proposed investigation, then it may be considered as falling into the second category (with the estimated cost calculated as that associated with the reproduction and modification alone).

The cost of contributed labor and services should be consistent with rates paid for similar work in the offeror's organization. The cost of contributions does not need to include funding spent before the start of the investigation (before completing a contract, grant, or cooperative agreement with NASA). The value of materials and supplies shall be reasonable and shall not exceed the fair market value of the property at the time of the contribution.

3. International Participation and Purchases of Non-U.S. Goods and Services

Participation by non-U.S. individuals and organizations as team members in SDO investigations is welcomed. Participation may include, but is not limited to, the contribution of scientific instruments and the subsequent sharing of the data from the mission, all on a no-exchange-of-funds basis. Contributions by international partners must be included in the cost estimate.

Proposers are advised that a contract or subcontract by a U.S. team with a non-U.S. participant using funds derived from NASA must meet all applicable NASA and Federal regulations (see Section 5.3). Proposers are further advised that these regulations will place an additional burden on investigation teams that must be explicitly included in discussions of the investigation's cost, schedule, and risk management.

Proposers for non-NASA OSS and also non-U.S. missions must recognize that all such proposals must be consistent, and in compliance with, all U.S. Government laws, regulations, and policies governing the export of hardware and/or technical data. Further, any such successful proposal will require the appropriate agreement(s) and export license(s). A discussion on Compliance with U.S. Export Laws and Regulations must be included in an Appendix to the proposal (see Table B-1, Section G.7, and G.8, all in this Appendix). Also, draft language for the technical content of any International Agreements must be provided as part of that Appendix.

The direct purchase of supplies or services, which do not constitute research, from non-U.S. sources by U.S. award recipients is permitted.

G. APPENDICES

The following additional information is required to be supplied with the proposal as Appendices to the proposal, and, as such, will not be counted within the specified page limit. NO OTHER APPENDICES ARE PERMITTED.

1. Resumes. Provide resumes or curriculum vitae for the PI, Co-I's, and funded science team members identified in the science section and named on the Cover Page and Proposal Summary. In addition, provide resumes for all key personnel identified in the Management section and for key E/PO lead personnel. Include data on experience relates to the job these personnel will be doing for the proposed investigation. Resumes or curriculum vitae must be no longer than two pages in length for each person.
2. Statement of Commitment from each Co-I. See Section C.2.d above in this Appendix.
3. Letters of Endorsement. Letters of endorsement must be provided from all organizations offering to supply goods or services or otherwise make a contribution to the investigation. Letters of endorsement must be signed by both the lead representative from each organization represented on the team, and, as may be necessary, by institutional or Government officials authorized to commit their organizations to participation in the proposed investigation. Signed letters of support or commitment must be provided from all E/PO partners or subcontractors detailing their commitment to or involvement in the education and public outreach effort.

In the case of science investigators who are providing their time, but not hardware/software or other tangible items, a letter from that investigator only will suffice. Copies of faxed or E-mailed letters from non-U.S. participants may be substituted in the hard copy proposals submitted by the deadline as long as signed letters are received by the date specified in the schedule provided in Section 8 of this AO. Endorsements from non-U.S. organizations should clearly identify which proposal is being supported by proposal name and PI name and be submitted to:

Solar Dynamics Observatory (SDO) Support Office
NASA Peer Review Services Suite 200
500 E Street, SW
Washington, DC 20024 USA

Fax Number: 202-479-9236

4. Statement of Work (SOW). For investigations managed from non-Government institutions, provide a SOW for all potential contracts with NASA. For investigations managed from Government institutions, provide a SOW as if the institution were non-Government. The SOW must include general task statements for Phase A/B/C/D and for Phase E for the investigation. All SOW's must include the following at a minimum: Scope of Work,

Deliverables (including science data), and Government Responsibilities (as applicable). SOW's need not be more than a few pages in length.

5. References. Proposals may provide a list of reference documents and materials cited in the proposal. The documents and materials themselves may not be submitted except as a part of the proposal (i.e., within the page limits).
6. Description of Team Member Selection (NASA PI's only). Proposals submitted by NASA employees as Principal Investigators must contain the following information concerning the process by which non-Government participants were included in the proposal. The proposal must (i) indicate that the supplies or services of the proposed non-Government participant(s) are available under an existing NASA contract; (ii) make it clear that the capabilities, products, or services of these participant(s) are sufficiently unique to justify a sole source acquisition; or (iii) describe the open process that was used for selecting proposed team members. While a formal solicitation is not required, the process cited in (iii) above must include at least the following competitive aspects: notice of the opportunity to participate to potential sources; submissions from and/or discussions with potential sources; and objective criteria for selecting team members among interested sources. The proposal must address how the selection of the proposed team members followed the objective criteria and is reasonable from both a technical and cost standpoint. The proposal must also include a representation that the Principal Investigator has examined his/her financial interests in or concerning the proposed team members and has determined that no personal conflict of interest exists. The proposal must provide a certification by a NASA official superior to the Principal Investigator verifying the process for selecting contractors as proposed team members, including the absence of conflicts of interest.
7. Technical Content of Any International Agreement(s). Draft language for the technical content of any International Agreement(s) are required for all non-U.S. partners in an investigation. A sample agreement is available in the SDO online Library (see Appendix C). The draft language should include (i) a brief summary of the mission and the foreign partner's role in it, (ii) a list of NASA's responsibilities within the partnership, and (iii) a list of the non-U.S. partner's responsibilities within the partnership. Note that NASA ordinarily establishes agreements with government funding agencies, not with the institution that will be funded to perform the work.
8. Discussion on Compliance with U.S. Export Laws and Regulations. Investigations that include international participation, either through involvement of non-U.S. nationals and/or involvement of non-U.S. entities must include a section discussing compliance with U.S. export laws and regulations; e.g., 22 CFR 120-130, et seq. and 15 CFR 730-774, et seq., as applicable to the scenario surrounding the particular international participation. Proposers must also comply with NASA FAR Supplement clause 1852.225-70 entitled "Export Licenses." The discussion must describe in detail the proposed international participation and is to include, but not be limited to, whether or not the international participation may require the prospective proposer to obtain the prior approval of the Department of State or the Department of Commerce via a technical assistance agreement or an export license, or whether a license exemption/exception may apply. If prior approvals via licenses are necessary, the proposal must discuss whether the license has been applied for or, if not, the

projected timing of the application and any implications for the schedule. Information regarding U.S. export regulations is available at the World Wide Web addresses given below. Prospective proposers are advised that under U.S. law and regulation, spacecraft and their specifically designed, modified, or configured systems, components, parts, etc., such as the instrumentation being sought under this AO, are generally considered "Defense Articles" on the United States Munitions List and subject to the provisions of the International Traffic in Arms Regulations (ITAR), 22 CFR 120-130, et seq.

Export Control References:

- The International Traffic in Arms Regulations (ITAR) can be found on the web at <http://www.pmdtc.org/reference.htm#ITAR>.
- Specific definitions of defense service, defense article, public domain, and technical data can be found in 22 CFR Part 120 and on the web at http://www.pmdtc.org/docs/ITAR/ITAR_120.txt.
- The U.S. Munitions List (items controlled un the ITAR) can be found in 22 CFR Part 121, and on the web at http://www.pmdtc.org/docs/ITAR/ITAR_121.txt.
- Export Administration Regulations (EAR) that control dual-use commodities and technical data, can be found at 15 CFR Parts 730-774 and on the web at http://w3.access.gpo.gov/bxa/ear/ear_data.html
- NASA Export Control Program can be found on the web at <http://www.hq.nasa.gov/office/codei/nasaecp>.
- The web site of the Department of Commerce Bureau of Export Administration, which administers the EAR, can be found at <http://www.bxa.doc.gov/>.
- The website of the Department of State Office of Defense Trade Controls, which administers the ITAR, can be found at <http://www.pmdtc.org/>

Table B-2. Total Investigation Cost Funding Profile
 (Costs by FY in Real-Year Dollars, Totals in Real-Year Dollars (RYK\$) and FY2002 K\$
 See Table B-5 for applicable Inflation Index)

Item	FY02	FY03	FY04	FY05	FY06	Subsequent Fiscal Years		Total (RY \$)	Total (FY02\$)
NASA Cost									
Phase A									
Phase B/C/D:									
WBS 1.0									
WBS 1.1									
WBS 1.2									
1.2.1									
1.2.n									
WBS 1.3									
WBS 1.4									
WBS 1.5									
WBS 2.0									
Phase E:									
WBS 3.0									
WBS 3.1									
WBS 3.2									
E/PO									
WBS 4.0									
WBS 4.1									
WBS 4.2									
Total NASA Cost	\$	\$	\$	\$	\$	\$	\$	\$	\$
Contributions:									
WBS 1.0									
.									
.									
WBS n.0									
Total Contributions	\$	\$	\$	\$	\$	\$	\$	\$	\$
						Total Invest. Cost		\$	\$

Costs must include all costs including overhead, G&A, and fees

Table B-3: Summary of Elements of Costs (see Instructions)

Instrument: _____

Check One: _____ PHASE A _____ BRIDGE PHASE

	FY02			FY03			FY04			Total		
	Hours	Rate	Cost	Hours	Rate	Cost	Hours	Rate	Cost	Hours	Rate	Cost
Direct Labor												
Labor Hrs/ Costs: (by skill categories)		\$	\$		\$	\$		\$	\$		\$	\$
Total Direct Labor Costs		\$	\$		\$	\$		\$	\$		\$	\$
Overhead (by cost Centers)		%	\$		%	\$		%	\$		%	\$
Other Direct Costs			\$			\$			\$			\$
Subcontracts			\$			\$			\$			\$
Materials			\$			\$			\$			\$
Material Burdens			\$			\$			\$			\$
Travel			\$			\$			\$			\$
Other Direct Costs			\$			\$			\$			\$
Subtotal			\$			\$			\$			\$
G&A Expense (by cost pools)		%	\$		%	\$		%	\$		%	\$
Subtotal			\$			\$			\$			\$
Cost of Money (by direct pools & overhead centers)		%	\$		%	\$		%	\$		%	\$
Profit/Fee		%	\$		%	\$		%	\$		%	\$
Total Cost Plus Fee			\$			\$			\$			\$

Cost Table Instructions for Table B-3

The Summary of Elements of Cost and Basis of Estimate for Phase A and the Bridge Phase should contain the following direct and indirect elements, as applicable:

- DIRECT LABOR HOURS – Show productive hours by individual skill categories.
- DIRECT LABOR COSTS – The labor costs should be itemized by skill categories. The basis for the rates should be described.
- LABOR OVERHEAD – Overhead should be itemized by overhead cost centers (engineering, manufacturing, etc.) as well as associated rates.
- SUBCONTRACTS – Supporting information, such as name/address, cost, fee/profit, basis of estimate, etc., should be provided for each of the major subcontracts.
- MATERIALS – Provide supporting details for major vendors. Burden rates must be identified.
- TRAVEL – Provide supporting details for destination, purpose, number of people per trip, transportation costs, per diem costs, and miscellaneous costs.
- OTHER DIRECT COSTS – Identify cost and purpose.
- GENERAL AND ADMINISTRATIVE (G&A) EXPENSE – G&A expense represents the institution's general and executive offices and other miscellaneous expenses related to business. G&A expense should be itemized by cost pool, and rates should be documented.
- COST OF MONEY (COM) – COM represents interest on borrowed funds invested in facilities. COM should be itemized by indirect pools and overhead centers. Rates should be documented.
- PROFIT/FEE – Document the basis, rate, and amount of fee.
- ESCALATION FACTORS – document the escalation factors used to determine real year dollars.

Table B-4: WBS Elements

1.0	Instrument Development
1.1	Postlaunch Science Ops
1.2	Postlaunch Data Analysis
1.2.1	Detector/focal plane array
1.2.2	Optics
1.2.3	Mechanisms
1.2.4	Power distribution
1.2.5	Structure
1.2.6	Electronics
1.2.7	Other major assemblies
1.2.8	Integration/assembly/test
1.3	Prelaunch Science Ops/DA/Algorithm Development
1.4	Special Launch Service Costs, if applicable
1.5	Special Ground Data System Costs, if applicable
2.0	Reserves
3.0	Science Ops & DA
3.1	Postlaunch Science Ops
3.2	Postlaunch Data Analysis
4.0	Education and Public Outreach
4.1	Prelaunch
4.2	Postlaunch

Table B-5: NASA Inflation Index

Fiscal Year	2002	2003	2004	2005	2006	2007	2008	2009
Inflation Rate	0.0%	2.8%	2.8%	2.8%	2.8%	2.8%	2.8%	2.8%
Cumulative Inflation Index	1.0	1.028	1.057	1.086	1.117	1.148	1.180	1.213

Use an inflation rate of 2.8% for years beyond 2009

APPENDIX C

BIBLIOGRAPHY OF RELEVANT REPORTS AND RECOMMENDATIONS

The SDO Library includes documents available electronically via the Internet, as well as paper copy. Proposers are requested to access the document electronically where possible. Only limited paper copies of documents are available. Please note that not all documents are available via the SDO Library, but access information is provided.

It is incumbent upon the proposer to ensure that the documents used in proposal preparation are of the date and revision listed in the Announcement of Opportunity or this Appendix.

The SDO Library is accessible on the World Wide Web at <http://sdo.larc.nasa.gov/SDOLibrary>.

Requests for paper copies should be submitted in writing to:

SDO Library
Mail Stop 160
Langley Research Center
National Aeronautics and Space Administration
Hampton, VA 23681-0001

Fax Number: (757) 864-8894
E-mail: c.l.daniels@larc.nasa.gov

Office of Space Science Strategies and Policies

The Space Science Enterprise Strategic Plan (November 2000)

This document is a concise statement of the goals and outlook of NASA's Space Science Enterprise. It is a compilation of the major ideas described in more detail in the context of the overall NASA Strategic Plan.

Partners in Education: A Strategy for Integrating Education and Public Outreach into NASA's Space Science Programs (March 1995)

This document describes the overall strategy for integrating education and public outreach into NASA's space science programs.

Implementing the Office of Space Science (OSS) Education/Public Outreach Strategy (October 1996)

This document describes OSS's overall approach to implementing its Education/Public Outreach strategy.

Office of Space Science Education and Public Outreach FY2000 Annual Report (February 2001)

As a consequence of the policies adopted by OSS, a major, national space science E/PO program is now underway, as reported in the above document.

Explanatory Guide to the NASA Office of Space Science Education and Public Outreach Evaluation Criteria (April 1999)

Answers to frequently asked questions, elaboration of each of the OSS E/PO criteria. Document is intended to give a flavor of what exemplary E/PO can be.

The Space Science Enterprise Integrated Technology Strategy (October 1998)

Describes efforts to manage technology infusion into future OSS missions and to promote technology transfer to the private sector.

Space Science Roadmaps

The Space Science Advisory Committee and its subcommittees have developed Roadmaps, planning documents that prioritize the space science goals for NASA for the years 2003-2023. The following Roadmap applies to the SDO project:

Sun-Earth Connection Roadmap, Strategic Planning for the Years 2000 - 2025 (September 1999)

Space Science Supporting Documents

Astronomy and Astrophysics in the New Millennium, NRC Astronomy and Astrophysics Survey Committee Report, (National Academy Press, 2001)

Living With a Star Science Architecture Team Report (August 30 2001)

SDO and LWS Guidelines and Requirements Documents

SDO Model Phase A Contract

SDO Science Definition Team report, The Solar Dynamics Observatory

LWS Mission Assurance Requirements (MAR)

LWS Education and Public Outreach Program Overview

Model Phase A Statement of Work (SOW)

Model Phase B-E Contracts

General Guideline and Requirements Documents

NPG 7120.5A—NASA Program and Project Management Processes and Requirements (April 1998)

This document provides a reference for typical activities, milestones, and products in the development and execution of NASA missions.

ISO 9000 Series

The following ISO 9000 quality documents describe current national and NASA standards of quality processes and procedures.

American National Standard, "Quality Systems - Model for Quality Assurance in Design, Development, Production, Installation, and Servicing," ANSI/ASQC Q9001-2000

"Quality Management and Quality System Elements - Guidelines," ANSI/ASQC Q9004-1-2000

"Quality Management and Quality Assurance Standards - Guidelines for Selection and Use," ANSI/ASQC Q9000-1-2000

"ISO 9000 and NASA," Code Q presentation (April 24, 1995)

Note: The first three ISO 9000-related documents are copyrighted and cannot be reproduced without appropriate compensation. For copies contact:

American Society for Quality Control (ASQC)
P.O. Box 3066
Milwaukee, WI 53201-3066
Ph: 1-800-248-1946

Procurement-related Information

Electronic versions only are available for the following in the SDO Library:

Federal Acquisition Regulations (FAR) General Services Administration

NASA FAR Supplement Regulations

NASA Financial Management Manual

NPG 5800.1D—Grant and Cooperative Agreement Handbook (July 1996)

Other

NASA Technology Database

Technology Readiness Level (TRL) Definition Chart

National Space Weather Program Implementation Plan, July 2000 (FCM-P31-2000)

Letter of Agreement (LOA) Template

STEREO Letter of Agreement (LOA) Example

Draft Code S Handbook, Chapter 7. Discusses the confirmation review process for Phase A to B Transition (section 7.3) and Phase B to C Transition (section 7.4).

APPENDIX D

CERTIFICATIONS

Included for reference only. Submission of the signed printout of web page as directed for the Cover Page/Proposal Summary certifies compliance with these certifications.

**Assurance of Compliance with the
National Aeronautics and Space Administration Regulations Pursuant to
Nondiscrimination in Federally Assisted Programs**

The (Institution or organization on whose behalf this assurance is signed, hereinafter called "Applicant.")

HEREBY AGREES THAT it will comply with Title VI of the Civil Rights Act of 1964 (P.L. 88-352), Title IX of the Education Amendments of 1972 (20 U.S.C. 1680 et seq.), Section 504 of the Rehabilitation Act of 1973, as amended (29 U.S.C. 794), and the Age Discrimination Act of 1975 (42 U.S.C. 16101 et seq.), and all requirements imposed by or pursuant to the Regulation of the National Aeronautics and Space Administration (14 CFR Part 1250) (hereinafter called "NASA") issued pursuant to these laws, to the end that in accordance with these laws and regulations, no person in the United States shall, on the basis of race, color, national origin, sex, handicapped condition, or age be excluded from participation in, be denied the benefits of, or be otherwise subjected to discrimination under any program or activity for which the Applicant receives federal financial assistance from NASA; and HEREBY GIVES ASSURANCE THAT it will immediately take any measure necessary to effectuate this agreement.

If any real property or structure thereon is provided or improved with the aid of federal financial assistance extended to the Applicant by NASA, this assurance shall obligate the Applicant, or in the case of any transfer of such property, any transferee, for the period during which the real property or structure is used for a purpose for which the federal financial assistance is extended or for another purpose involving the provision of similar services or benefits. If any personal property is so provided, this assurance shall obligate the Applicant for the period during which it retains ownership or possession of the property. In all other cases, this assurance shall obligate the Applicant for the period during which the federal financial assistance is extended to it by NASA.

THIS ASSURANCE is given in consideration of and for the purpose of obtaining any and all federal grants, loans, contract, property, discounts or other federal financial assistance extended after the date hereof to the Applicant by NASA, including installment payments after such date on account of applications for federal financial assistance which were approved before such date. The Applicant recognizes and agrees that such federal financial assistance will be extended in reliance on the representations and agreements made in this assurance, and that the United States shall have the right to seek judicial enforcement of this assurance. This assurance is binding on the Applicant, its successors, transferees, and assignees, and the person or persons whose signatures appear below are authorized to sign on behalf of the Applicant.

**Certification Regarding Debarment, Suspension, and
Other Responsibility Matters Primary Covered Transactions**

This certification is required by the regulations implementing Executive Order 12549, Debarment and Suspension, 14 CFR Part 1265.

- A. The applicant certifies that it and its principals:
- (a) Are not presently debarred, suspended, proposed for debarment, declared ineligible, or voluntarily excluded from covered transactions by any Federal department or agency;
 - (b) Have not within a three-year period preceding this application been convicted or had a civil judgment rendered against them for commission of fraud or a criminal offense in connection with obtaining, attempting to obtain, or performing a public (Federal, State, or Local) transaction or contract under a public transaction; violation of Federal or State antitrust statutes or commission of embezzlement, theft, forgery, bribery, falsification or destruction of records, making false statements, or receiving stolen property;
 - (c) Are not presently indicted for or otherwise criminally or civilly charged by a government entity (Federal, State, or Local) with commission of any of the offenses enumerated in paragraph A.(b) of this certification;
 - (d) Have not within a three-year period preceding this application/proposal had one or more public transactions (Federal, State, or Local) terminated for cause or default; and
- B. Where the applicant is unable to certify to any of the statements in this certification, he or she shall attach an explanation to this application.
- C. Certification Regarding Debarment, Suspension, Ineligibility and Voluntary Exclusion—
Lowered Tier Covered Transactions (Subgrants or Subcontracts)
- (a) The prospective lower tier participant certifies, by submission of this proposal, that neither it nor its principles is presently debarred, suspended, proposed for debarment, declared ineligible, or voluntarily excluded from participation in this transaction by any federal department of agency.
 - (b) Where the prospective lower tier participant is unable to certify to any of the statements in this certification, such prospective participant shall attach an explanation to this proposal.

Certification Regarding Lobbying

As required by S 1352 Title 31 of the U.S. Code for persons entering into a grant or cooperative agreement over \$100,000, the applicant certifies that:

- (a) No Federal appropriated funds have been paid or will be paid by or on behalf of the undersigned, to any person for influencing or attempting to influence an officer or employee of any agency, a Member of Congress, in connection with making of any Federal grant, the entering into of any cooperative, and the extension, continuation, renewal, amendment, or modification of any Federal grant or cooperative agreement;
- (b) If any funds other than Federal appropriated funds have been paid or will be paid to any person for influencing or attempting an officer or employee of any agency, Member of Congress, or an employee of a Member of Congress in connection with this Federal grant or cooperative agreement, the undersigned shall complete Standard Form—LLL, "Disclosure Form to Report Lobbying," in accordance with its instructions.
- (c) The undersigned shall require that the language of this certification be included in the award documents for all subawards at all tiers (including subgrants, contracts under grants and cooperative agreements, and subcontracts), and that all subrecipients shall certify and disclose accordingly.

This certification is a material representation of fact upon which reliance was placed when this transaction was made or entered into. Submission of this certification is a prerequisite for making or entering into this transaction imposed by S1352, title 31, U.S. Code. Any person who fails to file the required certification shall be subject to a civil penalty of not less than \$10,000 and not more than \$100,000 for each such failure.

APPENDIX E

EDUCATION AND PUBLIC OUTREACH

The education and public outreach (E/PO) element of the proposal should provide a summary of the benefits offered by the investigation beyond the purely scientific benefits. This section of the proposal should contain a description of E/PO objectives and the planned activities to be undertaken to achieve those objectives; demonstrate how those plans will actually be implemented; discuss how the program will be evaluated; describe the intended involvement of the Principal Investigator and or key science team members in the E/PO effort; address the involvement of appropriate educational personnel as well as plans/commitments for partnerships and collaborations with education and outreach organizations; describe how the effort will be organized and managed (including the identification of key personnel who will actually be responsible for overseeing and implementing the E/PO effort); and explain the requested E/PO budget showing how that budget is related to and supports the planned program. Plans for developing and disseminating education/outreach products and materials, for contributing to the training of underserved and/or underutilized groups in science and technology, and for coordination of the planned E/PO program with the umbrella LWS E/PO program should be addressed. Details of organizational and management arrangements described in the Management and Cost Plan may be included by reference and do not have to be repeated in this section of the proposal. Letters of support/commitment from partners and resumes of key E/PO personnel should be included in the appendices to the proposal. Note that no separate submittal of the E/PO proposal component is required.

The umbrella LWS E/PO program currently being defined will plan and implement a number of national efforts. These efforts have considerable breadth and depth; are multifaceted in nature; address a number of different aspects of education and outreach contained in the specific criteria; and have state, regional, or national scope. Therefore, the E/PO programs associated with PI proposals may be more focused and regional in nature and will be judged accordingly. Instrument investigation E/PO programs will have an opportunity to influence the planning and content of the overall program. Proposers should address their intended coordination with the GSFC LWS E/PO program as they carry out their own E/PO programs while acting as local agents for the LWS Program's more national efforts. The LWS E/PO Program Overview is included in the SDO Library (see Appendix C). Questions about the LWS E/PO program can be addressed to Ms. Evelina Felicite-Maurice at efilicit@pop400.gsfc.nasa.gov.

I. EVALUATION CRITERIA

There are eight evaluation criteria against which proposed OSS mission E/PO activities will be evaluated - four general criteria, three specific criteria, and one mission criterion. The general criteria to be applied to the evaluation of all such proposals and that reflect requirements necessary for further consideration of a proposal, are:

- the quality, scope, realism, and appropriateness of the proposed E/PO program, including the general intellectual linkage to the science objectives of the parent research proposal or mission;

- the adequacy, appropriateness, and realism of the proposed budget, including demonstration of effective use of funds;
- the capabilities and commitment of the proposer and the proposer's team to carry out the proposed E/PO program, including the direct involvement of one or more science team members in overseeing and carrying out the proposed E/PO program, as well as the establishment or continuation of effective partnerships with institutions and/or personnel in the fields of education and/or public outreach as the basis for and as an integral element of the proposed E/PO program; and
- the appropriateness of plans for evaluating the effectiveness and impact of the proposed education/outreach activity.

To ensure that the goals and objectives of the OSS E/PO strategy are realized in practice, proposals will also be evaluated using one or more of the following specific criteria as appropriate. The specific E/PO criteria are:

- when dealing directly or strongly affecting the formal education system (e.g. teacher workshops or student programs carried out at public institutions, such as science museums and planetariums), the degree to which the proposed E/PO effort is aligned with and linked to nationally recognized and endorsed education reform efforts and/or efforts at the state or local levels;
- the degree to which the proposed E/PO effort contributes to the training, involvement, and broad understanding of science and technology by underserved and/or underutilized groups; and
- the potential for the proposed E/PO activity to expand its scope by having an impact beyond the direct beneficiaries (e.g., reaching relatively large audiences, being suitable for replication or broad dissemination, and/or drawing on resources beyond those directly requested in the proposal).

The mission criterion to be explicitly considered as part of the evaluation of the E/PO component of all proposals is:

- The relationship of the planned E/PO program to any unique scientific or technical aspects of the SDO mission.

Plans for coordination of the proposed activities with the umbrella LWS E/PO program and other ongoing OSS E/PO efforts will also be explicitly considered in the evaluation process.

In all cases, note that while creativity and innovation are certainly encouraged, none of these criteria focuses on the originality of the proposed effort. Instead, NASA seeks assurance that the proposer is personally committed to the E/PO effort and that the PI and/or appropriate research team members will be actively involved in carrying out a meaningful, effective, credible, and appropriate E/PO activity; that such an activity has been thoughtfully planned and will be

carefully executed; and that the proposed investment of resources will make a significant contribution toward meeting OSS E/PO goals and objectives. OSS expects E/PO to be handled just as thoroughly and professionally as are the scientific and engineering aspects of OSS missions.

To aid proposers in the preparation of their proposals, as well as to ensure that reviews are carried out on a consistent basis aligned with the OSS Education Strategy and Implementation Plan, an Explanatory Guide to the E/PO evaluation criteria has been prepared and may be found in the SDO Program Library (see Appendix C).

The two key documents that establish the basic policies and guide all OSS education and outreach activities are a strategic plan entitled *Partners in Education, A Strategy for Integrating E/PO Into NASA's Space Science Programs* (March 1995), and an accompanying implementation plan entitled *Implementing the OSS E/PO Strategy* (1996) (see Appendix C). Both can also be accessed by selecting "Education and Outreach" from the menu on the OSS homepage at Internet URL <http://spacescience.nasa.gov>, or from Dr. Jeffrey Rosendhal, Office of Space Science, Code S, NASA Headquarters, Washington, DC 20546-0001, USA. Additional information on the ongoing OSS E/PO Program (including information on how to contact the E/PO leads of current programs) can be found in the FY 2000 E/PO Annual Report, which may be accessed through this same internet link. The FY 2001 Annual Report is expected to be available on-line in early January 2002.

II. ASSISTANCE FOR THE PREPARATION OF E/PO PROPOSALS

NASA OSS has established a nation-wide support network of space science education/public outreach groups whose purpose is to directly aid space science investigators in identifying and developing high quality E/PO opportunities. This support network provides the coordination, background, and linkages for fostering partnerships between the space science and E/PO communities, and the services needed to establish and maintain a vital national, coordinated, long-term OSS E/PO program. Of particular interest are two elements of this network (also described in more detail in the OSS education/outreach implementation plan referred to above):

- Four OSS science theme-oriented E/PO "Forums" sponsored by NASA OSS to help orchestrate and organize in a comprehensive way the education/outreach aspects of OSS space science missions and research programs, and provide both the space science and education communities with ready access to relevant E/PO programs and products; and
- Seven regional E/PO "Broker/Facilitators" sponsored by NASA OSS to search out and establish high leverage opportunities, arrange alliances between educators and OSS supported scientists, and help scientists turn results from space science missions and programs into educationally appropriate activities suitable for regional and/or national dissemination.

Prospective proposers are strongly encouraged to make use of these groups to help identify suitable E/PO opportunities and arrange appropriate alliances. However, while these Forums and Broker/Facilitators are commissioned by OSS to provide help, the responsibility for actually developing an E/PO program and writing the proposal is that of the proposer. Points of contact

and addresses for the E/PO Forums and Broker/Facilitators may be found by opening Education and Public Outreach from the menu of the OSS homepage at <http://www.spacescience.nasa.gov>.

BUDGET SUMMARY for
Education/Public Outreach Proposal

For (check one):

___ Total Period of Performance from (M/Y) _____ to _____
/or/
___ Year ___ of ___ from (M/Y) _____ to _____

1. Direct Labor (salaries, wages, and fringe benefits)	
2. Other Direct Costs:	
a. Subcontracts	
b. Consultants	
c. Equipment	
d. Supplies	
e. Travel	
f. Other	
3. Facilities and Administrative Costs	
4. Other Applicable Costs	
5. SUBTOTAL—Estimated Costs	
6. Less Proposed Cost Sharing (if any)	
7. Total E/PO Estimated Costs	