

# ARM

CLIMATE RESEARCH FACILITY

## Total Precipitation Sensor HANDBOOK

---

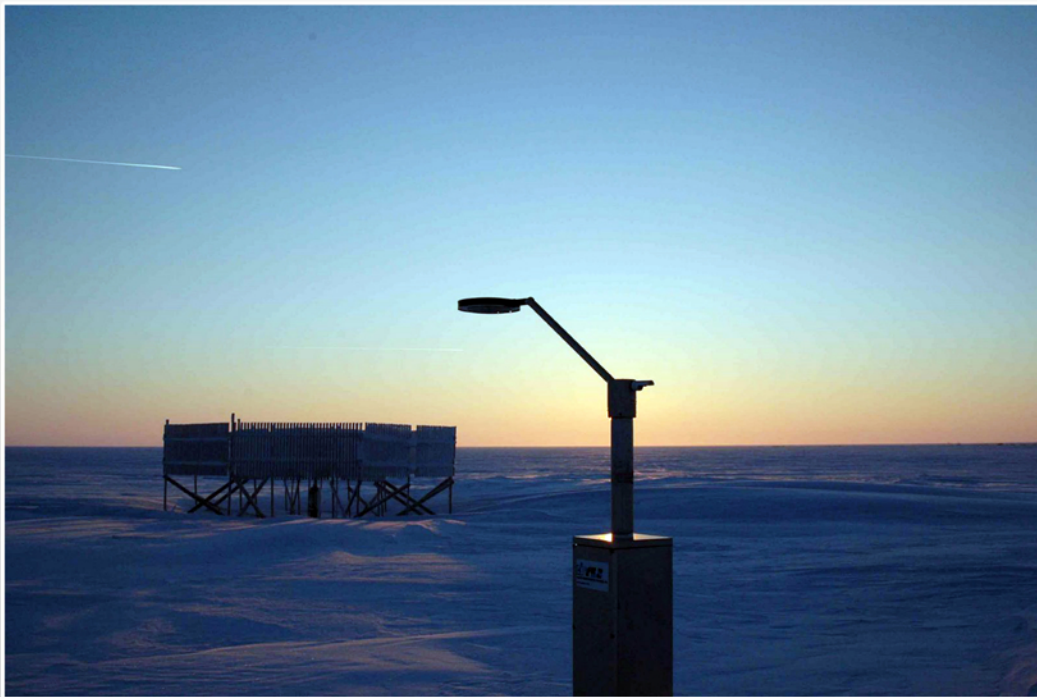

February 2011



U.S. DEPARTMENT OF  
**ENERGY**

Office of  
Science

Work Supported by the U.S. Department of Energy  
Office of Science, Office of Biological and Environmental Research

## **DISCLAIMER**

This report was prepared as an account of work sponsored by the U.S. Government. Neither the United States nor any agency thereof, nor any of their employees, makes any warranty, express or implied, or assumes any legal liability or responsibility for the accuracy, completeness, or usefulness of any information, apparatus, product, or process disclosed, or represents that its use would not infringe privately owned rights. Reference herein to any specific commercial product, process, or service by trade name, trademark, manufacturer, or otherwise, does not necessarily constitute or imply its endorsement, recommendation, or favoring by the U.S. Government or any agency thereof. The views and opinions of authors expressed herein do not necessarily state or reflect those of the U.S. Government or any agency thereof.

# **Total Precipitation Sensor (TPS) Handbook**

February 2011

Work supported by the U.S. Department of Energy,  
Office of Science, Office of Biological and Environmental Research

## **1.0 Introduction**

The total precipitation sensor (TPS), installed at the Atmospheric Radiation Measurement (ARM) Climate Research Facility's North Slope of Alaska (NSA) site, measures atmospheric temperature, horizontal wind, and precipitation.

The Installation and User Guide for the TPS-3100 is included here with the permission of Yankee Environmental Systems, Inc., the instrument's manufacturer.

# **TPS-3100 Total Precipitation Sensor**

**Installation and User Guide**  
*Version 2.0*

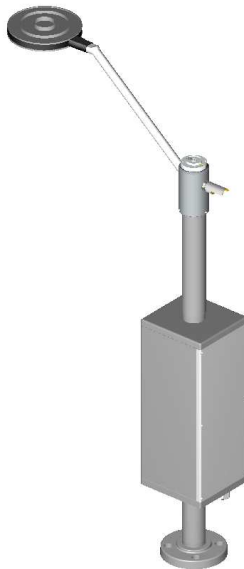

**TPS-3100 Total Precipitation Sensor**

*Rev M 1/6/2011*



**YANKEE ENVIRONMENTAL SYSTEMS, INC.**

Copyright © 2005-2011 Yankee Environmental Systems, Inc. All rights reserved. Other Company and product names used herein may be the trademarks or registered trademarks of their respective companies.

The information in this document is subject to change without notice.

The Trademark Hotplate®, is a registered trademark of the University Corporation for Research of Boulder, Colorado, USA (registration # 3,068,982, issued 3/14/06), and is used under license. The Hotplate® technology is covered by the following U.S. Patents: #4,744,711, Winter Precipitation Measuring System, #6,546,353, Hot Plate Precipitation Measuring System; and the following continuing patents: #6,708,133, (Issued 3/16/04); #6,714,869; (Issued 3/30/04); #6,675,100, (Issued 1/6/04); #6,711,521 (Issued 3/23/04); #5,751,571 (Issued 6/15/04).

Yankee Environmental Systems, Inc.  
Airport Industrial Park  
101 Industrial Blvd.  
Turners Falls, MA 01376 USA

Phone: 413-863-0200  
FAX: 413-863-0255  
E-mail: [info@yesinc.com](mailto:info@yesinc.com)  
<http://www.yesinc.com>

# Contents

<b>1</b>	<b>Overview .....</b>	<b>1-1</b>
	Principle of Operation .....	1-2
	<i>Internal CPU Operation</i> .....	1-4
	<i>Why the Hotplate is Better than Traditional Gauges</i> .....	1-4
	<i>Estimating Snow Depth from LER</i> .....	1-6
	<i>Hydrological Forecasting and Remote Sensing</i> .....	1-7
	<i>Detecting Blowing Snow with Dual Systems</i> .....	1-8
	<i>Development History</i> .....	1-9
	Specifications.....	1-11
<b>2</b>	<b>Installation .....</b>	<b>2-1</b>
	Preliminary Assembly and Checkout .....	2-2
	Preliminary Site Selection .....	2-5
	Permanent Site Installation.....	2-9
	<i>Installing the Support Post</i> .....	2-10
	Lighting Protection Considerations .....	2-13
	Wiring the System .....	2-15
	<i>Using Dial-up (V.9X) Hayes Modems</i> .....	2-15
	<i>Making the Electrical Connections</i> .....	2-16
	<i>AC line power connection</i> .....	2-17
	<i>Safety Ground: Connecting to Earth Ground</i> .....	2-18
	<i>Operating Away from AC Grid Power</i> .....	2-21
	<i>Communications Connection</i> .....	2-21
	<i>Installing the Serial-to-Ethernet COM Redirector</i> .....	2-22
	Hardware Connection to Data Management Systems .....	2-24
	Preliminary Checkout .....	2-26
	Configuring the Pulse Accumulation Output .....	2-27
<b>3</b>	<b>Using the System.....</b>	<b>3-1</b>
	Understanding the Command Line Interface.....	3-2
	Output Data Record Formats .....	3-4
	<i>Checking ASCII Strings Against the Checksum</i> .....	3-4
	Setting the Real Time Clock and Time Zone .....	3-6
	Interactive vs. Streaming Data Output Mode .....	3-8
	Resetting the Accumulator .....	3-10
	Entering Verbose Mode.....	3-11
	Setting System Elevation.....	3-12
	Using Tipping Bucket Mode .....	3-13
	<i>Setting Tipping Bucket Tip Amount</i> .....	3-13
	System Reset.....	3-14
	Interpreting Fault Event Codes and Status LEDs .....	3-15
	<i>Understanding LED States for Fault Detection</i> .....	3-16
<b>4</b>	<b>Maintenance.....</b>	<b>4-1</b>

Routine Maintenance .....	4-2
Accessing Internal Components .....	4-4
System Checkout Procedure .....	4-8
<i>Performing a Simple Drip Test</i> .....	4-8
Changing the AC Line Voltage or Replacing Fuses.....	4-11
<i>Replacing Internal Fuses</i> .....	4-12
Replacing the RTC Lithium Battery.....	4-14
Replacing the Sensor Head.....	4-15
Breaking Down and Packing the System for Shipment.....	4-17
Important Product Safety and Disclaimer Information.....	4-20
Product Warranty.....	4-21
Documentation Feedback .....	4-22



# In This Manual

The *TPS-3100 Installation and User Guide* describes how to set up and use the Yankee Environmental Systems, Inc., Model TPS-3100 Total Precipitation Sensor.

## What this manual covers

This manual covers the following topics:

CHAPTER	CONTENTS
1 Overview	General information about the system, including specifications and principle of operation
2 Installation	Procedures for setting up the system
3 Using the System	How to interpret serial output data
4 Maintenance	Routine maintenance procedures that you should perform; information on servicing the system

If you have a question about operating your system but cannot find the answer you need in this manual, contact YES Technical Support via:

## Technical support

- **Web:** <http://support.yesinc.com> (or *Support* section at [www.yesinc.com](http://www.yesinc.com))

**Caution:** *Please read this manual before setting up and using your system.* Because the sensor plates are hot during normal operation, it should only be powered on outside and mounted out of the reach of unauthorized personnel. Never operate the system within the reach of young children while they are unattended, and be sure to keep your hands and fingers clear of the hot sensing surface components while it is powered on. See the section on page 4-17.



# CHAPTER 1

## Overview

---

The Model TPS-3100 *Total Precipitation Sensor* is a state-of-the-art, automatic precipitation gauge designed for remote, unattended operation in all weather conditions. The system consists of a thermodynamic precipitation sensor head and electronics enclosure that is physically integrated together as a single unit. Its rugged no-moving-parts design ensures reliable snow and rain rate measurements during long term unattended use at remote weather stations.

The advanced Hotplate® thermodynamic sensing technology represents the first fundamental breakthrough in precipitation measurement in several decades, and is ideal for mission-critical meteorological applications that span the road, rail and aviation transportation sectors.

### Features

System features include:

- Low-maintenance no-moving-parts design
- Does not require a wind shield (e.g. Alter or Wisconsin-type fences)
- Fully automatic operation with internal diagnostics
- Flexible interfaces compatible with surface meteorological weather stations

Typical applications include:

### Applications

- Real time snow rate for roadway transportation weather information systems
- Checktime™ aircraft de-icing decision aids
- ASOS/AWOS professional or “scientific-grade” surface weather stations
- EPA regulatory site compliance and baseline monitoring
- Scientific research on global climate change for model calibration
- Research on Chemical/Biological/Nuclear agent dispersion

The sensor measures instantaneous *total wet deposition*, where wet deposition includes both liquid and frozen precipitation events. Statistically, precipitation rates can be highly variable in both time and space, and therefore single measurements only reflect a limited space-time domain. The measurement of *liquid equivalent rate* (LER) of precipitation, especially mixed/frozen precipitation, is fundamental to disciplines as diverse as transportation safety and global climate change research. The technique has the unique ability to provide real time precipitation rate *and* wind. Some scientists believe insensitivity of rain gauges (due to vortex effects) biases our climatological precipitation database.

## Principle of Operation

### Differential Power Measurement

The Hotplate® sensor consists of two individually heated plates five inches in diameter. Precisely controlled electrical heaters maintain the plates at the same elevated temperature, where the top plate is exposed to precipitation while the lower plate, insulated from the upper plate, is shaded and not exposed to precipitation. By measuring the difference in power required to maintain the two plates at the same elevated temperature, the precipitation rate can be calculated. The difference in thermal energy required to evaporate rain or snow off the independently controlled top plate yields instantaneous *liquid equivalent rate* (LER). Power delivered to the lower plate is used to factor out wind cooling, which yields a useful measurement of wind speed. The instantaneous precipitation rate is thus derived from the power difference between the two plates, after a correction for both ambient temperature and wind speed.

Ground and air transportation managers have traditionally relied on snow gauges with manually-emptied buckets that require anti-freeze. Typically, wind shields are required around these legacy gauges to increase their “catch efficiency”, especially with snow. These shields, together with anti-freeze additives, result in labor intensive operation, prone to user errors and equipment failure precisely when data are most needed. In contrast, the Hotplate technology never freezes and has no moving parts. It produces true real time precipitation measurements, avoiding many of the problems with legacy sensors, while providing reliable accuracy over a  $\pm 50^{\circ}\text{C}$  range.

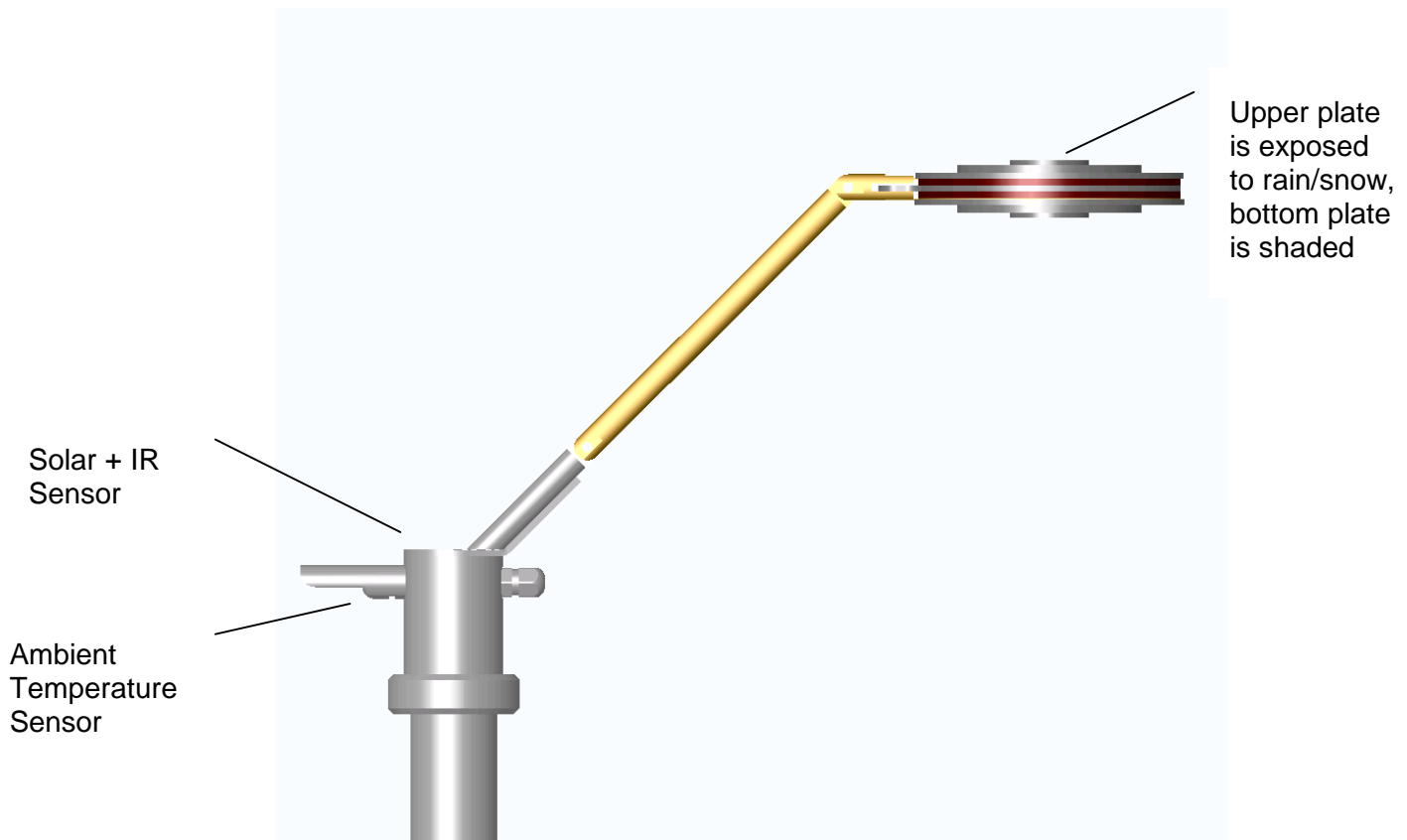

Figure 1. Side view of sensor head. Solar/IR and PTU sensors are at top of post.

## Liquid Equivalent Rate

Note that the instantaneous LER tends to be relatively independent of the form of precipitation occurring, (i.e. snow vs. rain). LER is calculated based on an internal algorithm that was developed along side common scientific-quality rain gauges. Once one knows the present LER, it is possible to convert to snow depth by scaling (as described in Estimating Snow Depth on page 1-6), as long as an assumption of snow type is possible.

Accurate real time snowfall rates upwind of a region during the evolution of potentially dangerous snow and ice storms, enables optimization of de-icing and snow removal operations. Reliably detecting the very earliest stages of a snow storm is often critical to the managing snow clearing operations. The key to ensuring accurate frozen precipitation measurement performance is snow *catch efficiency*. Compared to conventional orifice-type gauges, the Hotplate® technique captures nearly all hydrosols (with exception of large hail) and can detect very light snow within a minute of the onset of the event. In contrast, conventional tipping bucket gauges require accumulation of an entire liquid droplet before they indicate precipitation; it can take as long as an hour for a droplet of precipitation to melt and ultimately migrate to their sensor below.



Figure 2. TPC at the US Department of Energy's North Slope Alaska site. A Double Fenced Intercomparison Rain gauge is located in the background.

## Data Interfaces

Several interface methods are available: *TPS-Manager* will display data in real time on your MS-Windows PC if it is direct connected via a RS-232 serial cable, or via the optional serial-to-Ethernet interface and your TCP/IP LAN. For permanent integration with Data Management Systems, the serial port is typically direct-wired for continuous ASCII data transfer. If auxiliary meteorological data and diagnostics are not necessary, a simulated accumulated precipitation accumulation pulse output can interface with analog data loggers.

## Low Maintenance

With no moving parts to freeze or wear out the system is virtually maintenance free and is ideal for remote, difficult-to-access areas. Precipitation tends to keep the plates relatively clean and the very warm surface temperature of the plates tends to keep birds from landing on them.

## Internal CPU Operation

---

The system is controlled by an embedded microprocessor that:

- At power up, heats the plates to a preset elevated operating temperature, and then continuously adjusts power to maintain plates at a constant temperature
- Processes auxiliary sensor data from integrated solar, infrared, and pressure, temperature, humidity ambient sensors
- Continuously measures plate power and ambient temperature; the calculated power difference between the plates indicates incident precipitation rate
- Outputs sensor data either on command or continuously, and monitors the serial port for commands and processes them

**Note:** The Hotplate® name is protected by US trademark (registration #3,068,982, issued 3/14/06), and the TPC-3100 technology is covered by the following U.S. Patents: #4,744,711, Winter Precipitation Measuring System, #6,546,353, Hot Plate Precipitation Measuring System; and five continuing patents: #6,708,133, (Issued 3/16/04); #6,714,869; (Issued 3/30/04); #6,675,100, (Issued 1/6/04); #6,711,521 (Issued 3/23/04); #5,751,571 (Issued 6/15/04).

## Why the Hotplate is Better than Traditional Gauges

---

Many techniques have been developed over the years to automatically measure precipitation, including weighing and tipping bucket gauges. Most involve measuring either the *weight* or *volume* of accumulated rain or snow. The fundamental challenge of these methods comes from the polar nature of the water molecule itself: It takes a large amount of thermal energy to change the state of water. Thankfully, water's significant latent heat of vaporization greatly stabilizes our climate.

However, while most molecules reduce their size as they cool and change phase from liquid into solid, as water freezes it expands. This can generate forces on the order of tens of thousands of pounds per square inch, which leads to road surface cracking. With nearly all traditional weighing rain gauges this expansion eventually leads to mechanical internal component damage and reduced accuracy.

We can perhaps best summarize the winter maintenance challenge that occurs by quoting the instruction manual from a conventional weighing-type rain gauge:

“When the gauge is operating below 0°C, an antifreeze blend must be added to the solution in the bucket to melt frozen precipitation and prevent freezing. If the precipitation freezes the ice will rise above the oil and sublimation will occur. It is important to notice that the capacity of the collected precipitation is decreased when antifreeze is added. The antifreeze becomes a part of the total volume collected. Two types of antifreeze are available, Ethylene glycol and the more environmentally friendly Propylene glycol. Methanol is then added to both to adjust the density of the antifreeze to prevent stratification. Tables in the following sections

show the amount of antifreeze needed to keep the collected precipitation from freezing at various temperatures ...”

### Zero Operational Maintenance

Manually tending a rain gauge during the colder months by keeping it filled with anti-freeze chemicals is tedious, expensive and prone to human error. By using heat to maintain precipitation in the liquid state, it *eliminates troublesome mechanical forces created as liquid water freezes to ice*. A related challenge during winter storm events for precipitation measurement is the ambient temperature will often vary dramatically through a 12-hour period, often by as much as 40°C. If the operator fails to continuously monitor temperature the window of opportunity to deploy antifreeze may be missed. At remote sites the maintenance logistics become formidable.

### Catch Efficiency

Even when anti-freeze is properly added and accounted for, a second major advantage of the Hotplate® technology over legacy precipitation sensors is its *outstanding catch-efficiency* in snow. Precipitation gauge must measure mass flow across an aperture opening. In most traditional rain gauges, a vertical pipe acts as this orifice. Because the bottom of the pipe is closed (similar to an organ pipe), in light snow or windy conditions, there tends to be a pressure oscillation inside the pipe that precludes or enhances snowflakes that ballistically enter the collection orifice. Further, snow often sticks to the inside of the pipe and then sublimates off directly into a vapor, thus it never reaches the bottom of the pipe where it is supposed to be measured. The shaded lower plate is used to measure the wind speed, which is used to compensate for wind effects by the control algorithm.

### Wind Shields Unnecessary

While in terms of catch efficiency rain presents less of an issue vs. snow, high wind speeds make it difficult to catch all the precipitation faithfully, leading to a reduction in accuracy. Various mechanical windshield contraptions have been developed over the years in an attempt to block wind around traditional rain gauges (e.g., Alter, Wisconsin, etc.) As snow impacts the heated top plate, it is immediately either turned into a liquid or vaporized to gas. This “sticky” adhesion provides exceptional catch efficiency in snow leading to its unsurpassed accuracy. There is *no need for mechanical shielding*; research has shown a wind shield in close proximity tends to lower accuracy by virtue of the turbulence it creates.

### Wind Speed Measured at Same Location

Another advantage of the technique is that *it measures wind speed precisely at the same location of the precipitation measurement*. The statistics of precipitation and wind measurements are well known; if you set out four well calibrated gauges just a few meters apart you will routinely observe a significant deviation that is due to the random process of rainfall. The wind has the same random spatial variation, in particular, the direction, which is dominated by local turbulence. Over time, these differences will average out. However, wind blown rain remains a major factor with many types of wind sensors. In particular, during precipitation ultrasonic wind sensors are really measuring the terminal fall velocity of the hydrosols, *not* the wind speed. At the initial onset of a storm, high winds modify the catch efficiency of traditional gauges and reduce their sensitivity, biasing their measurements downward. Meanwhile, purely thermodynamic techniques measure wind speed reliably up to ≈25 m/s.

## Real Time Data Saves Money

Finally, unlike rain gauges, the electronically-controlled thermal technique captures light precipitation at the onset of the storm and *provides measurements immediately*. This behavior uniquely identifies the initiation of the storm event. Whereas some scientific quality gauges are able to measure as low as 0.1mm per hour, they can require many minutes for droplets to migrate down to the measurements sensor in a strain gauge or tipping bucket. This means significant time elapses before the signal is actually registered and reported by the sensor. During periods of very light snow, aside from the fact that snow is often sticky. If accumulated solid precipitation does happen to melt into liquid, during migration to the weighing sensor increased surface areas tend to help promote evaporation before a measurement can actually occur. In contrast, a Hotplate® provides data within a minute of onset of snow or rain events; providing real time measurements during the lightest or precipitation events.

Such real time rate performance can literally be a matter of life and death in directing winter snow and ice clearing operations. Alternatively, it can help ensure financial success at ski areas, helping them shut down energy-intensive snow making and allowing nature to take over. Depending on the scale of the operation, the rapid response of the system helps it rapidly pay for itself through energy savings. For budget-limited government organizations, it allows you to safely stretch your snow removal budgets; sensors placed strategically upwind of storms enable the coordination of more efficient snow removal efforts. Finally, reducing the amount of chemicals on roadways not only saves money on deicing chemicals and sand, but also reduces their negative impacts on your local environment.

## Limitations of the Method

Of course, no instrument is perfect. If the wind is blowing at gale force and snow is literally blowing horizontally, measurement accuracy suffers. During heavy hail, larger particles ballistically bounce off the top plate, and the LER will be underreported. While the system can keep up with the heaviest of snow rates, in warmer climates when the liquid precipitation rate exceeds ~4" per hour, depending on wind speed and ambient temperature the system may under report LER. Essentially, if the heaters are unable to maintain the plates at the elevated set point to evaporate all of the liquid, the system accuracy will suffer until the downpour subsides and LER is under reported. However, during these statistically rare conditions the output data flat line saturates. This unnatural data and provides an obvious visual cue to permit identification of out of range measurements. While such conditions are rarer as you move away from the tropics, to accommodate such extremes typical best practice to capture high rain rate events is to co-locate a conventional tipping bucket gauge with the system.

---

## Estimating Snow Depth from LER

Automated measurements of precipitation hydrosol accumulated depth, especially in the frozen or partially-frozen state, has historically been a challenge. From the *Liquid Equivalent Rate* measurement parameter, we can often calculate accumulated snow depth as long as we can make an assumption. Snow is a complex parameter from a definition standpoint, and in order to quantify it we must begin with an unambiguously definition of the parameters. For reproducibility reasons, artificially melting snow and then measure the depth of its incompressible liquid form is a useful concept. However, in practice doing



this requires time, leads to partial evaporation and therefore reduces time response and generally under-reports the measurement.

## Snow Depth from Liquid Equivalent Rate

Relying on LER to obtain snow depth leads requires us to ascertain snow density, or *specific density*, which is defined as “the mass ratio relative to liquid water.” This parameter translates to a fraction of snow depth vs. water equivalent after melting. Once deposited on the ground, the snow pack compresses over time due to hydrostatic pressure and crystal shape change. In the arctic, snow is denser the deeper we dig and it eventually turns into glacier solid ice below a depth of between 10–100m, where air bubbles in the ice turn into *clathrates*.

Assuming that we are only considering very recent snowfalls, in the AMS Glossary of Meteorology (p.695) explains that freshly fallen snow at 0°C; between 0.07 to 0.15m translates to a value of about 0.17. This value implies that the snow will melt to  $\approx 0.17$  *liquid equivalent water* of the originally deposited uncompacted solid depth. However, at an air temperature of -10°C, this value falls down to  $\approx 0.07$  and at still lower temperatures it falls to  $\approx 0.004$ , although this number depends a bit on what is termed snow *habit*. In contrast, solid ice has a value of 0.92 and the theoretical “wet snow in no air” has a value of 0.95. The latter is an ice-plus-water mix, and depends on the mixing ratio, where by definition, liquid water alone must have a value of 1.0.

We can usually rely on past meteorological experience and the general stability of inland snowstorms over their life cycles to infer the depth of freshly fallen snow from LER, snow density and air temperature. For example, if we consider a snow storm, for example, western North America dry powder snow, or a Northeaster’s heavy wet storm near 0°C, we can use knowledge of the ambient temperature to assume snow *type*. We can also extract snow *wetness* from atmospheric pressure, or via a camera or human observation of snow type. Note the snow type parameter can be visually recorded by the YES TSI Total Sky Imager, whereupon it is remotely identified by a human operator. Near shorelines or in cases where a frontal pressure change dramatically alters snow type during the storm, the accuracy of predicting snow depth from LER may be somewhat reduced as habit is dynamically altered.

---

## Hydrological Forecasting and Remote Sensing

The Hotplate® meteorological measurement technology supports real time Hydrological forecasting. Large river basins are heavily impacted by snow run off in the spring, and accurate flash flood advisories still represent a significant operational challenge. An excellent web course *Techniques in Hydrological Forecast Verification* is available at the MET-ED web site run by the University Corporation for Atmospheric Research:

[http://meted.ucar.edu/hydro/verification/techniques\\_hydro\\_verif/](http://meted.ucar.edu/hydro/verification/techniques_hydro_verif/)

Related to hydrological forecasting, a growing number of microwave remote precipitation sensing platforms are now on orbit. These platforms require ground truth data to validate and calibrate newly-developed microwave remote sensing precipitation retrieval algorithms. An example NASA/Japan Space Agency *Tropical Rainfall Measurement Mission* (TRMM) <http://trmm.gsfc.nasa.gov> which uses Hotplate® sensors to verify cold weather precipitation retrievals.

## Detecting Blowing Snow with Dual Systems

---

An interesting challenge with snow removal operations is the reliable and automatic detection of *blowing* snow as opposed to just LER. In addition, remote sensing and global circulation models that attempt to account for the effects that blowing snow has on the Earth's albedo need ground truth data. By helping quantify the effect blowing snow has (how reflective the earth's surface is), such measurements should lead to improved accuracy of climate change models.

The basic technique of differencing the power required to individually maintain the top and bottom plates at a constant elevated temperature can be used to derive conditions of blowing snow. Recall the system uses the bottom plate power as a correction for wind speed. However, blowing snow can contact the lower plate, which renders the wind correction inaccurate.

The use of two systems held at different altitudes can detect blowing snow by comparing the lower plates and comparing the difference. Either separate wind sensors can be used, or the wind speed measured by the system mounted higher off the ground can be used along with well known wind profiles, based on the knowledge of the vertical spacing.



Figure 3. Multi-level tower wind system at North Dakota State University.

Blowing snow measurement requires the following two parameters:

1. Wind speed must be independently measured via a trusted co-located wind sensor that is assumed to be independent of blowing snow. This auxiliary wind measurement is used to detect that the increased cooling of the lower plate(s) caused by blowing snow and not only due to cooling by the wind.
2. Multiple independent TPS-3100 measurements located at several heights (e.g. 2m and 10 m) can provide vertical profiles of blowing snow, while retaining the ability to detect the onset of very light snow events.

To detect blowing snow two systems are mounted upwind on a tower, one at 2m and the second at 10 m. If possible, two calibrated heated anemometers are placed orthogonally of each sensor at these heights but on their own cross arm to minimize turbulence. Note the unique feature of the technology is it measures wind speed exactly at the same location as the precipitation.

Real time intensity of precipitation LER is assumed to be similar for each sensor at the two heights, whereas wind measurements are assumed to either match the anemometers (if present) or curve fit to the ground effect of wind profiles. Variance from expected wind speed indicates the presence and general magnitude of blowing snow impacting the lower plate on the lower sensor. More than two sensors can be used to achieve increased vertical resolution, and the optional serial-to-Ethernet system interface is simplifies wiring.

## Development History

---

The Hotplate® technology has been developed by [Yankee Environmental Systems](#), in close partnership with the [National Center for Atmospheric Research](#) (NCAR) in Boulder, Colorado and the [Desert Research Institute](#) (DRI) of Reno, Nevada. As is often the case, necessity was the mother of the invention: Research scientists John Hallett and Roy Rasmussen were frustrated by practical issues. Conventional precipitation gauges freeze during colder weather, resulting in significant precipitation measurement errors.

Initial National Science Foundation and Federal Aviation Administration funding supported their pioneering parallel plate thermodynamic measurement concept, which eventually led to a family of US patents. The technology the system uses today represents more than a decade of continuous R&D and careful long term field studies near Denver, Colorado and the Mount Washington Observatory in New Hampshire. In 2003, UCAR [licensed the technology](#) to YES for commercial production. Wind speed tests were later conducted in the Wright wind tunnel at Massachusetts Institute of Technology confirming the accuracy of the wind speed retrieval algorithm.

In late 2010, four auxiliary sensors were added to system hardware quantify solar radiation, infrared thermal radiation, atmospheric pressure and relative humidity. These parameters are reported along with precipitation rate, wind speed and ambient temperature. These sensors feed internal corrections to eliminate statistically-rare environmental conditions where nature fools the system:

- First, during the daytime precipitation events when the sun is not obscured by cloud the direct normal sunlight heats the top plate reducing measurement. Sensitivity.
- Second, during cold cloudless nighttime periods thermal emission from the top plate out to the  $\sim 2.7^{\circ}\text{K}$  [cosmic background](#) through the atmospheric infrared window cools the top plate causing the system to believe it was snowing lightly when it is not.

While these sensors effectively watch for and filter out these edge cases, as a side benefit, the evolution of the system's technology has produced the world's first truly no-moving-parts *thermodynamic weather sensor* that provides high reliability performance under the harshest cold weather conditions where legacy meteorological sensors fail.

## Specifications

CHARACTERISTIC	DESCRIPTION
Power Required	100/250 Vac, 50/60Hz, 1 $\Phi$ ; 100W typ, 680W max
Weight	17 lbs. (8 kg), not including mounting post
Size	72" (183cm) H; 22" (55cm) D; 8" (20cm) W. Note: mounting post determines total overall height.
Materials	Aluminum
Digital I/O	RS-232, 9600 baud 8-N-1 ASCII
Analog output	Simulated tipping bucket rain gauge output, Open Collector
Measurement range	0-50 mm hr <sup>-1</sup>
Liquid Equivalent Rate accuracy	$\pm 0.5$ mm hr <sup>-1</sup>
Time Constant	1 minute
Slew rate	$\approx 0.5$ mm s <sup>-1</sup>
Repeatability	$\pm 0.25$ mm hr <sup>-1</sup>
Hysteresis	None
Resolution	0.1 mm-hr <sup>-1</sup>
Wind Speed	0-25 meter-sec <sup>-1</sup> ; accuracy $\approx 1$ meter-sec <sup>-1</sup>
Auxiliary Met Measurements	Ambient Temperature ( $^{\circ}$ C): 2% FS accuracy Atmospheric Pressure (milliBar): 2% FS accuracy Relative Humidity (%): 5% FS accuracy Solar Radiation (Watts-m <sup>2</sup> ): 5% FS accuracy Net Thermal Infrared Radiation: "T <sub>ambient-to-sky</sub> " (Watts-m <sup>2</sup> ), 10% FS accuracy
Operating Temp range	$\pm 50^{\circ}$ C
Initial Power on delay	10 minutes (permits thermal stabilization)
Running average period	5 minutes, 1 minute (see text)
Electrical Connections	Internal DB9 pin Female (DCE) RS-232, separate pulse output simulates tipping bucket sensor for data loggers with counter inputs. 6' (1.8m), AC line cord to internal screw terminal strip.

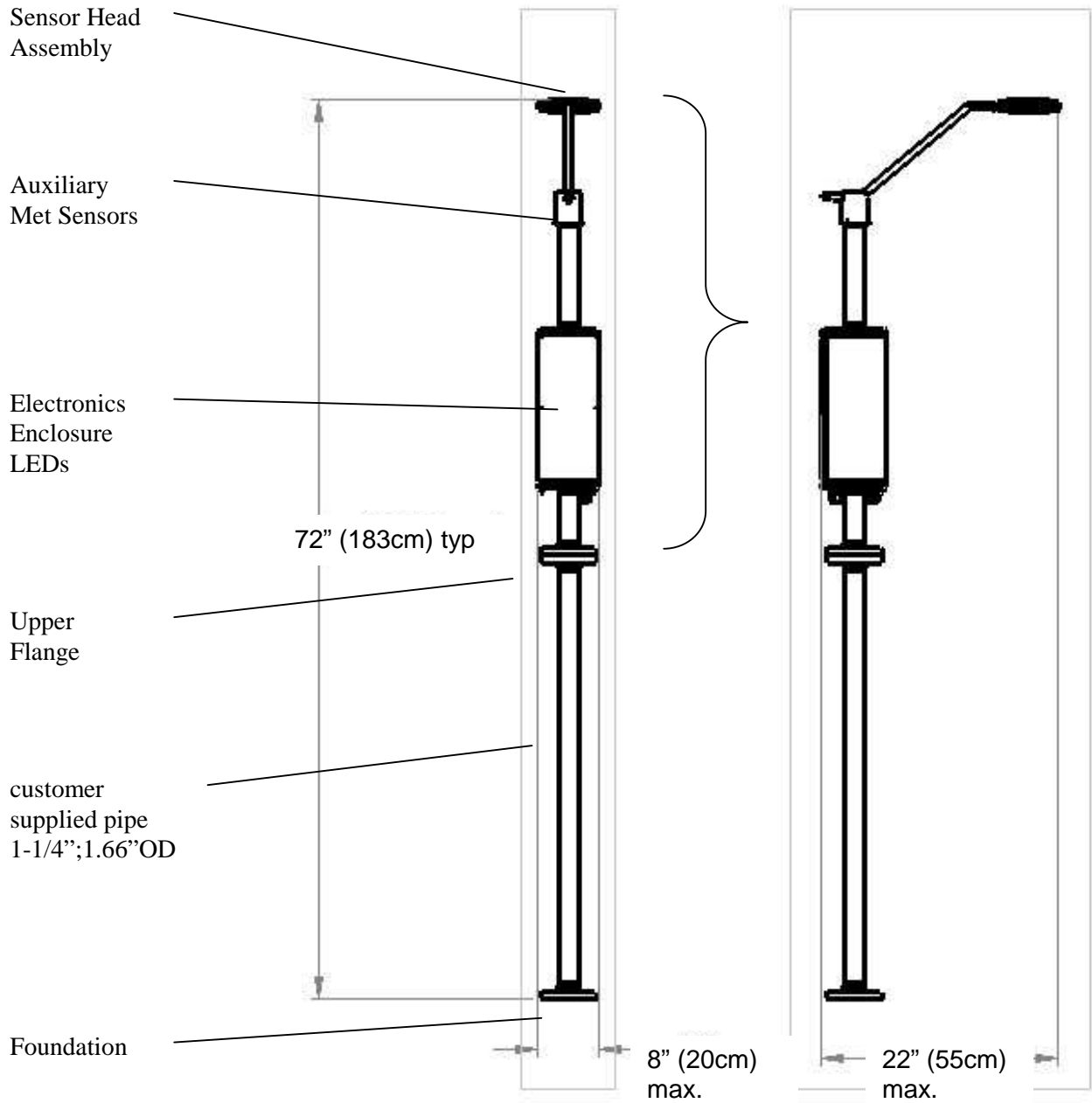

Figure 4. Mechanical Interface Drawing for a typical installation, dimensions in inches (cm). System is supplied with a post between electronics enclosure and "Upper Flange" point, but is shown here mounted attached to on customer-supplied stand built from two flat pipe flanges and a 36" section of threaded pipe. Total sensor height above ground is controlled by the mounting post, and is typically 5-6 feet to maintain the plates out of reach of animals and small children.

# CHAPTER 2

## Installation

---

This chapter covers unpacking the system, preliminary checkout and permanent installation at a monitoring site.

<b>Topic</b>	<b>Page</b>
• Preliminary Assembly and Checkout	2-2
• Preliminary Site Selection	2-5
• Permanent Site Installation	2-9
• Lighting Protection Considerations	2-13
• Hardware Connection to Data Management System	2-24
• Lighting Protection Considerations	2-13

The physical installation process consists of the following tasks:

- Preliminary mechanical assembly
- Planning for permanent mounting at the site,
- Making necessary communications and AC electrical connections
- Performing system operational tests to verify the system is working properly.

This chapter describes each task.

### **Installation process**



## Preliminary Assembly and Checkout

### Save the shipping containers

Your system was shipped partially disassembled and consists of a sensor head tethered sensor to the electronics enclosure. After you've unpacked the system, save the box in case you need to ship the system in the future.

You may wish to familiarize yourself with the system by physically mating the sensor head to the electronics enclosure. A convenient method to work on the system is to use a large C-clamp to hold the electronic assembly's lower mounting flange plate down to the surface of a workbench as shown below in Figure 5. This holds the system vertically, allowing you to position the sensor head at the top of the system electronics enclosure. You do not have to tighten down the three screws just yet, the idea is to get the plates somewhat level.

**Caution:** The system electronics enclosure is sealed to keep water out and should only be opened if you absolutely require access. The enclosure door must be properly re-sealed to prevent water infiltration and *evidence of water will void your product warranty*. If you must open it carefully follow the procedure in section Accessing Internal Components on page 4-4 and note the position of the gasket for re-assembly. Use particular care to route the sensor cable harness the same way to avoid pinching the wire harness during re-assembly.

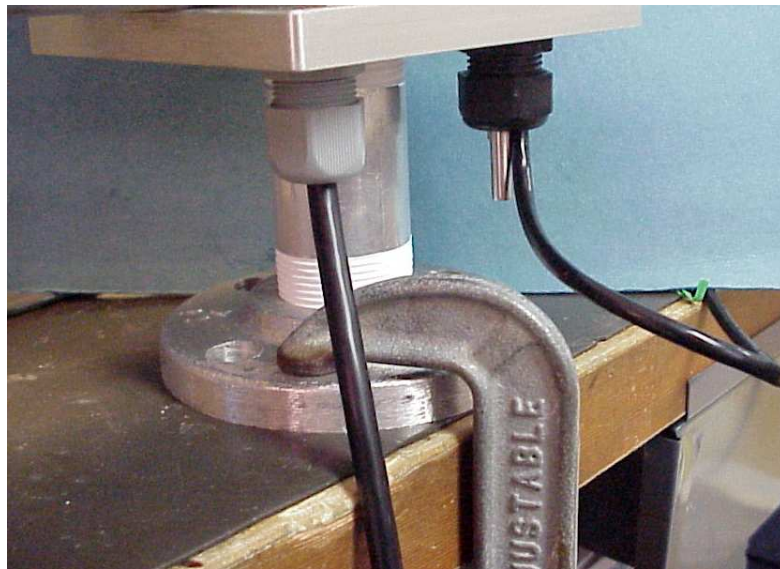

Figure 5. Using a C-clamp to temporarily hold system on a workbench.

Once the sensor head is mechanically mated to the electronics enclosure you can get familiar with the system by using a MS-Windows PC or laptop and the *TPC-Manager* data viewer.

- 1 Connect the RS-232 serial cable to a serial port on your PC. If you do not have a serial port you can add one by using a Belkin USB-RS-232 adapter.
- 2 Run the **setup** program to install the *TPS-Manager* data viewer. Note the latest version is available here: <ftp://support.yesinc.com/software/tps-3100/>





- 3 Configure *TPS-Manager* to use the COM $n$  serial port you plugged cable into.
- 4 As shown in Figure 6, click on the *start* to initiate operation.
- 5 Next, with the system sitting vertically, apply AC power and wait for the 10-minute warm up period to elapse, observing the system LEDs through the window on the side of the enclosure.
- 6 During this warm up test, the sensor head will become warm and cannot be in contact with your work surface. Observe the TPS-Manager screens, verify that the serial data stream is changing after the system warms up.
- 7 You can put a small amount of water on the top plate as described in System Checkout Procedure on page 4-8 to explore how the system reacts to the onset of precipitation. Note that in extremely still indoor conditions you may observe a “chimney effect” that results in slight thermal imbalance.

On the side of the electronics enclosure is a small window that allows you to view red, yellow, green and blue status LEDs. The blue, orange and yellow LEDs indicate system power is present; during operation you may observe:

- steady red: system in warm-up phase
- flashing green: system OK, normal operation
- flashing red, green off: internal system error

A system error either indicates:

- top or bottom plate, current, voltage or resistance is out of range (check condition code for details), or
- external ambient temperature thermistor has a wiring fault (ensure it is connected to the main controller internally)

Start Control

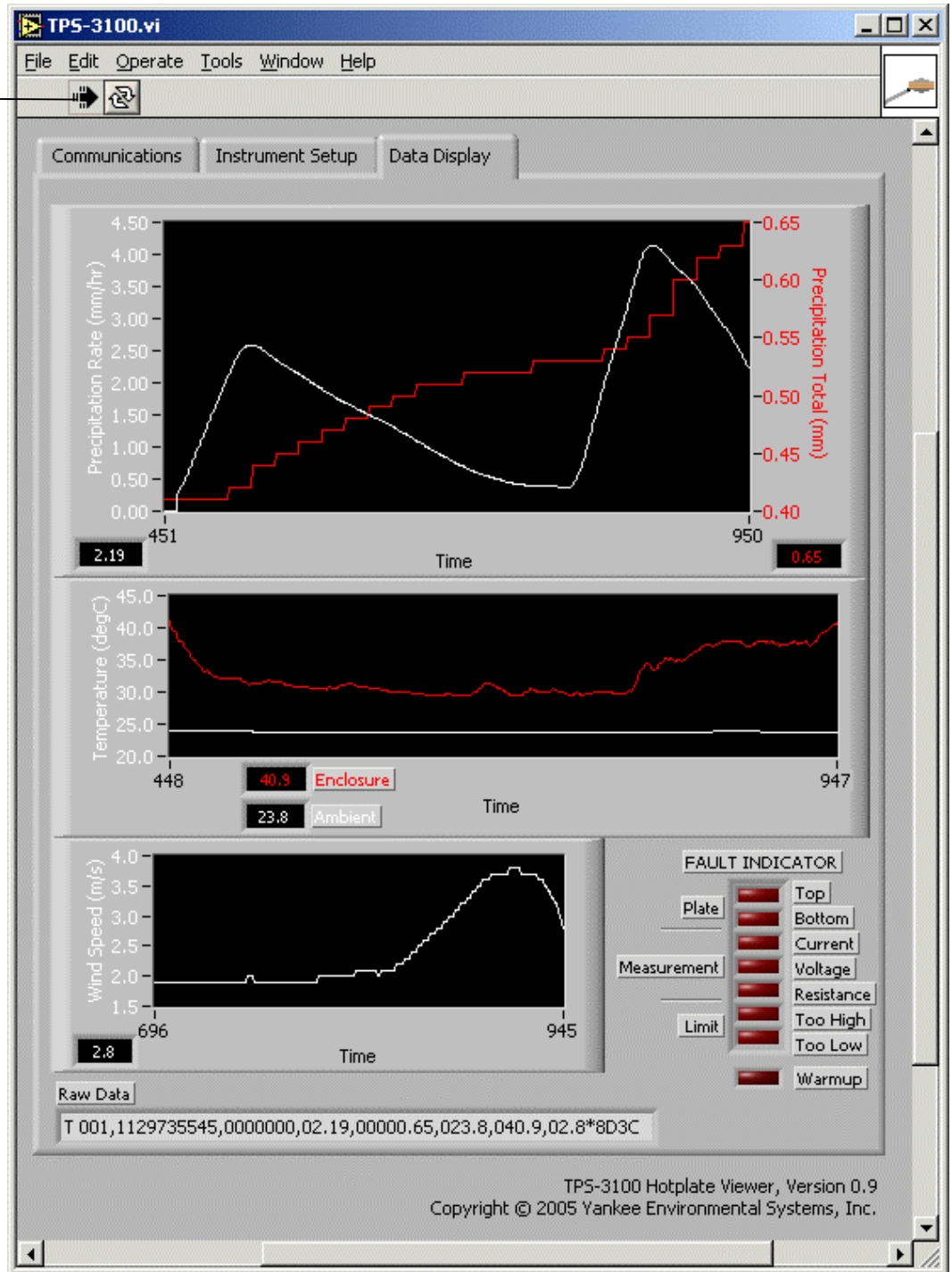

Figure 6. TPS-Manager real time display (note display varies with version).

## Preliminary Site Selection

Proper site selection is important for best performance; an open flat field is ideal. You essentially want to ensure that wind flow will be largely laminar, which means that the system must not be installed near hills, earthen berms, stockade fences, buildings, stone walls, bushes or trees. In addition, you should maintain the area under the sensor free of any ground vegetation that might increase local wind turbulence. In particular, installing on a mountain side will lead to measurement errors as anabatic (inflow/uphill) or katabatic (outflow/downhill) diurnal wind flows will affect each plate slightly differently. Best performance results from avoiding nearby objects, including:

- Buildings, walls or fences
- Vegetation such as trees or bushes
- Hills/slopes or berms/swales in the earth
- Tall structures such as weather instruments or met towers

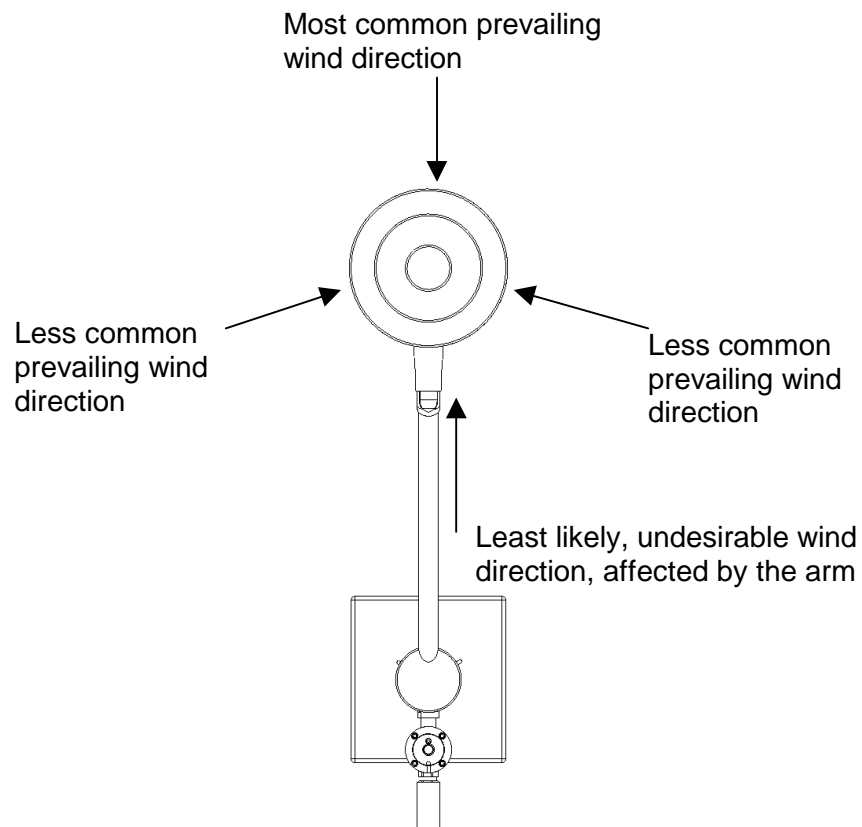

Figure 7. To avoid the effects of turbulence created by the sensor support, aim the head into the direction of the statistically most likely winds (arm should be downwind).

Ideally, locate the system far from nearby objects. Tall buildings and trees create wind turbulence at distances of ten diameters of their height. Turbulence creates non-laminar wind flows that lead to an imbalance between the plates being misinterpreted as precipitation, when it is really turbulence. For best overall accuracy and performance the system must be installed in an open, flat area, well away from any object that might generate downwind wind turbulence.

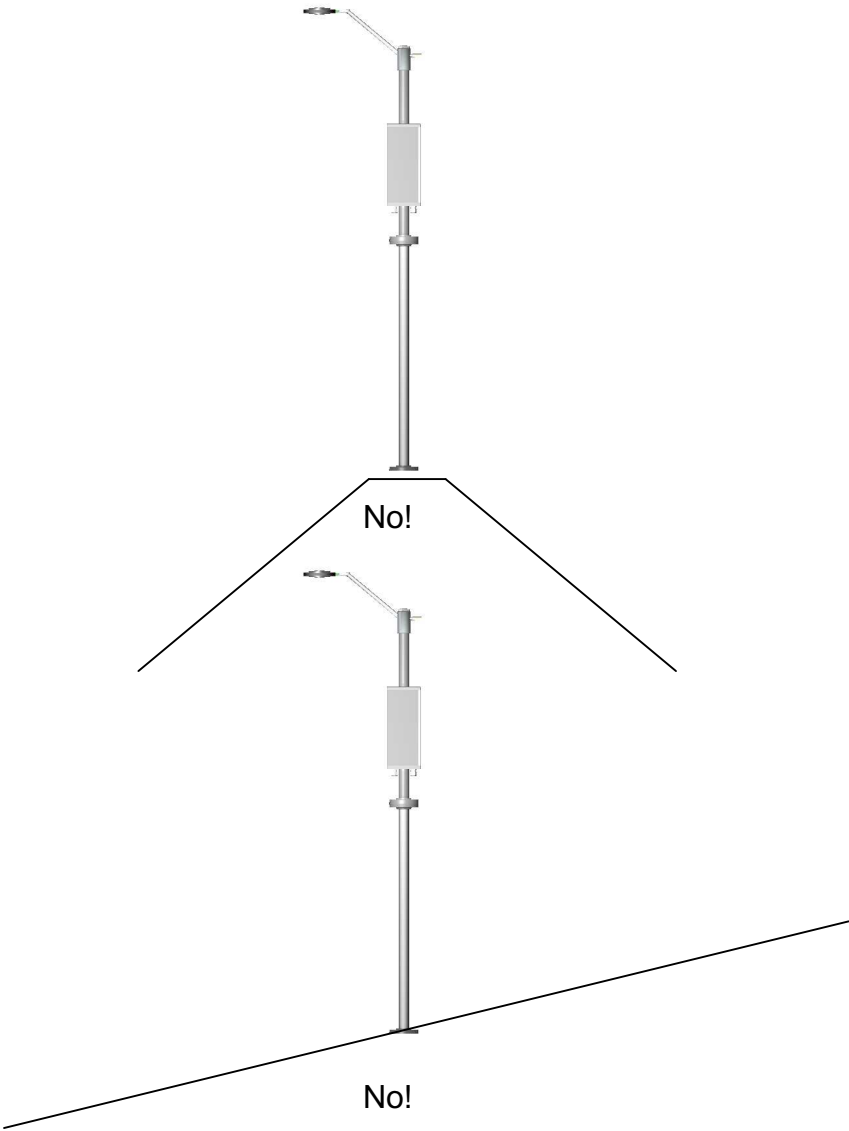
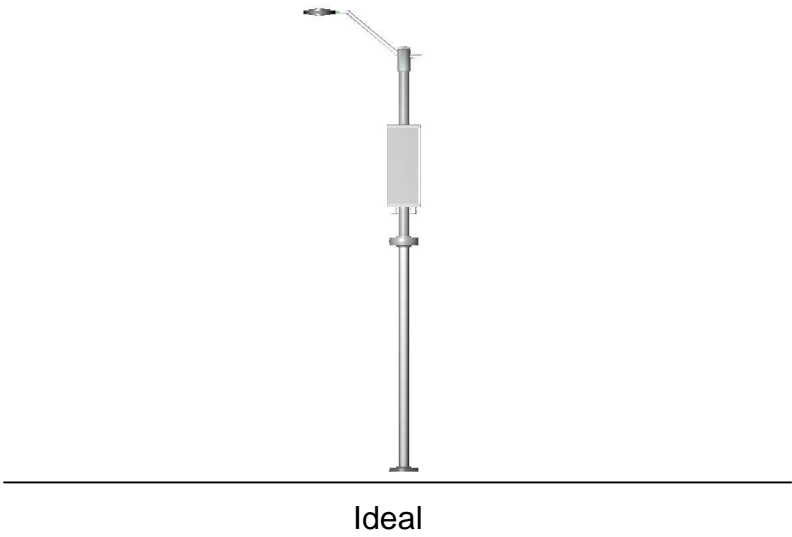

Figure 8. Mount the system on a flat surface, avoiding roof peaks or slopes.

You should pour a concrete pad below the worst case frost line, located well away from objects listed at the start of this section. The overall goal is to have as few obstacles as possible within a close radius—the center of a large, level open field is best. Be particularly careful to avoid positioning the sensor near large structures or at the top of slopes, as diurnal winds coming up and down a slope will create turbulence and non-lateral wind flows. In mountain valleys these sloped winds can extend vertically to hundred of meters.



Figure 9. Subtle site issues that can create unwanted local wind turbulence.

With nearly all sites, there are practical compromises that must be made simply due to the fact that total reconfiguration is impractical. The key points are to avoid mounting atop pointed roofs, near walls or fences or on sloped areas.

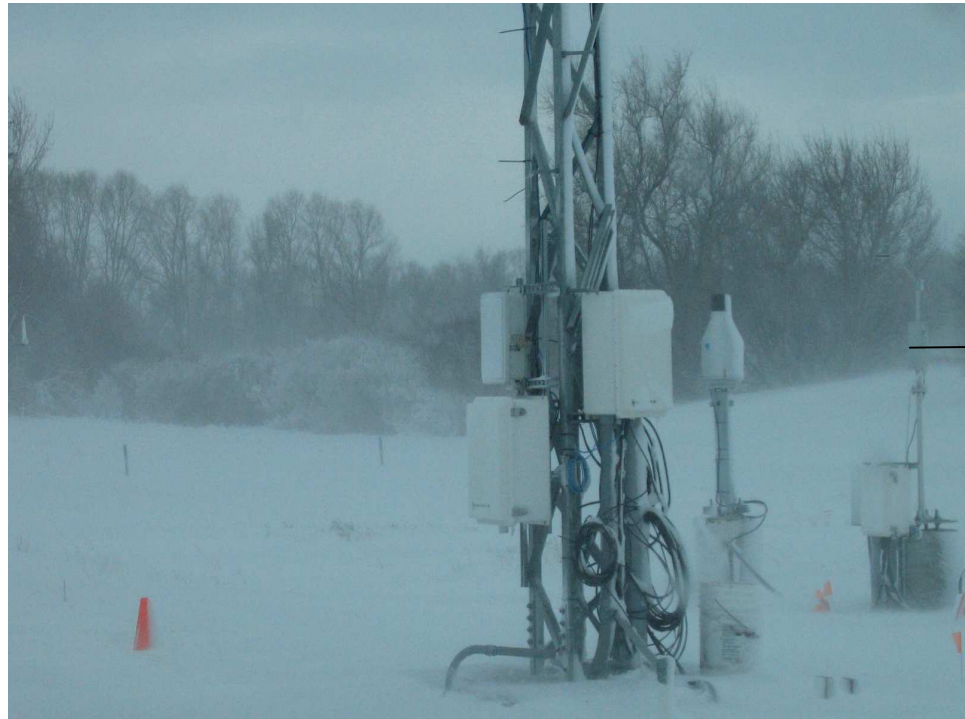

TPS

Figure 10. In addition to creating complex downwind turbulence, nearby towers will drop accumulated precipitation in random, complex patterns around their bases.

**Caution:** The sensor operates at elevated temperatures and you can be burned if you physically touch the sensor plates while it is powered on. This is more likely to happen if you setup the system improperly, close to the ground. If you cannot mount the sensor out of reach of people, install a fence such that children and unauthorized personnel are denied physical access to it at all times. Ensure the fence is installed far enough away to avoid creating wind turbulence. Installation factors are not within the control of the manufacturer and it is your responsibility to install and use the system properly.

## Permanent Site Installation

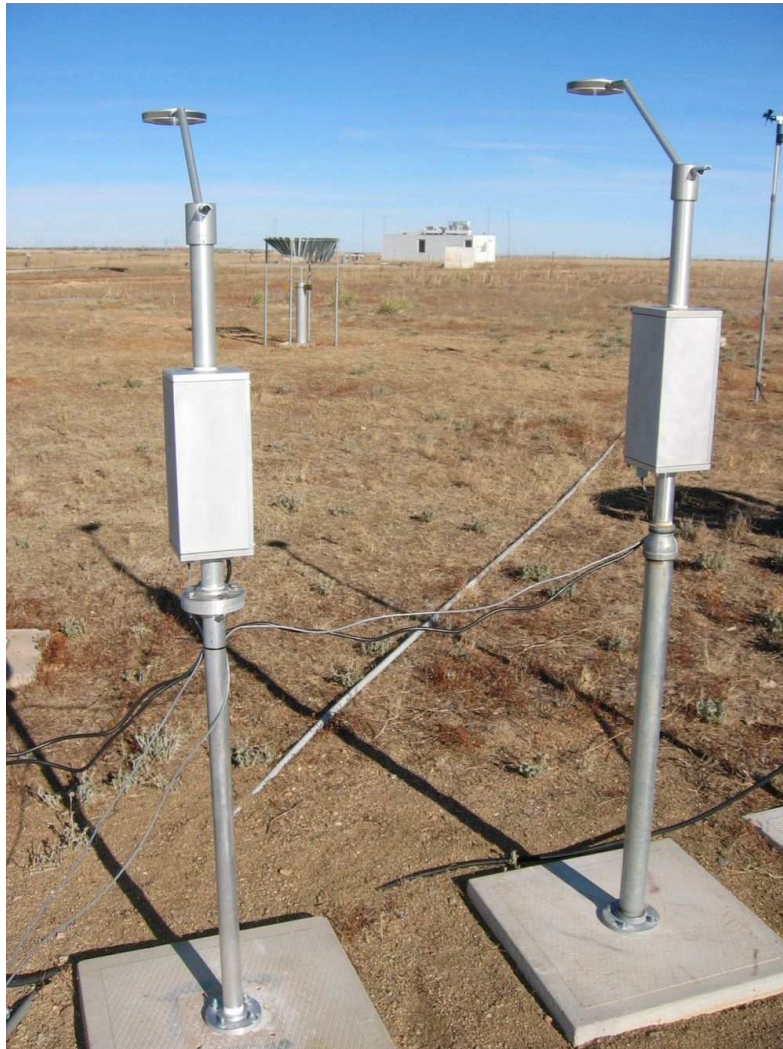

Figure 11. Example of poured concrete pad mounts; to avoid downwind turbulence from arm point head into the statistically most common wind direction.

**Keep away from hills,  
walls or other  
obstructions**

Mount the system atop a vertical threaded pipe secured into a poured concrete pad in a flat open area to minimize turbulence. Again, slopes walls and tall obstacles create local wind turbulence that differentially biases the plates, reducing measurement accuracy.

The concrete foundation should be poured deep enough to remain steady at all times over the life of the system. If your area experiences winter frost it must extend well below the worst case frost line. The optimum size and depth of the concrete foundation depends on the local maximum frost depth, as well as the makeup of the soil. Other factors may come into play such as whether the soil has been disturbed by recent construction, or by years of annual agricultural plowing. Existing steel posts can be welded to in some cases if they are sturdy and buried deep enough. Essentially, the sensor assembly must be maintained level. While not damaging, physical movement resulting in tilt will lead to measurement errors.

## Installing the Support Post

The top plate and solar sensors must remain level at all times, but especially in high wind conditions. The long moment arm of the support necessitates using a sturdy support. The system is secured using the mounting holes on the supplied pipe flange by bolting it to a flange threaded into a vertical pipe set into a concrete pad. A heavy schedule-80 galvanized steel conduit pipe embedded in concrete with a threaded mating to a 4" pipe flange is ideal. If digging is impractical, a wide and very sturdy wooden deck built above the snow line should be adequate.

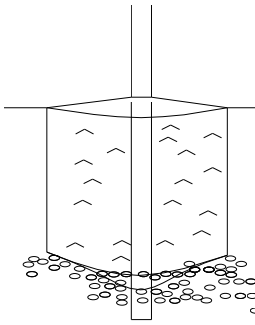

Excavate the soil deep enough to avoid movement from frost heaves or dynamic forces caused by winds. The height of the finished concrete is usually about 4" higher than flush with the ground. Dig the concrete hole well below the local frost line—a general guideline at mid-latitudes is 6' deep. A typical concrete foundation width is 2' square. Purchase a 10' section of rigid galvanized schedule 80 steel conduit from a local electrical supply vendor and fixture it to hold it vertical to within  $\pm 1^\circ$  before you pour. You can use a 18" or larger sonnet tube as a form, but this is not required.

### Pipe in Concrete

If you are mounting the system on rocky soil, the best mechanism is to secure the post with a steel bar reinforced (rebar) concrete foundation. In some types of rock you can drill holes for anchor bolts and epoxy them in. If you have access to the tools, bore a hole in the rock for the post at least 36" deep ( $\approx 1\text{m}$ ). Alternatively, drill and then epoxy grout anchor bolts in place at minimum depth of 200 mm. If you must install in areas of solid rock and you do not have access to a pneumatic air rock drill, pour a thick rebar reinforced Alaskan slab foundation directly on top of the exposed rock and fixture four 12" L x  $\frac{3}{4}$ " dia. foundation "J-Bolts", poured into concrete for mating with to the pipe flange.

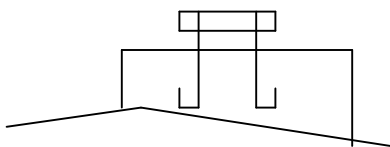

### Alaskan Slab

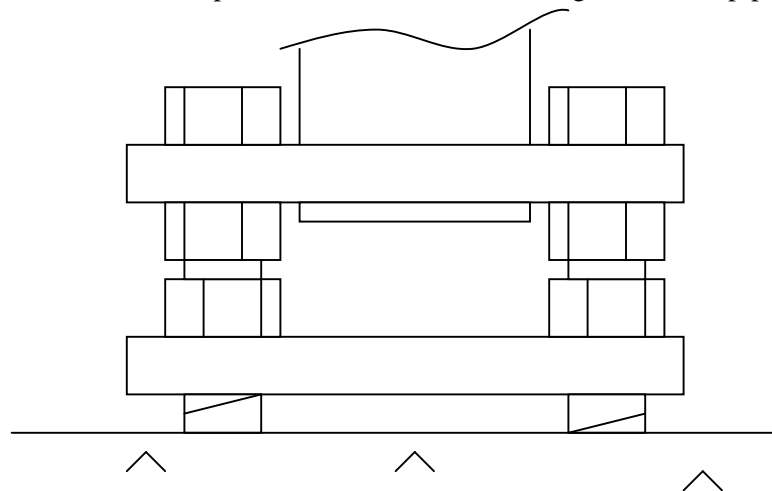

Figure 12. Example of using bolts and two flanges to keep post vertical.

Use a pipe flange as a fixture to securely hold the J-bolts in place while the concrete dries. Wait two days for the concrete to fully set before mounting.

To allow an adjustment for leveling of the entire electronics assembly, you can add extra nuts to the bolts, one on each J-bolt as shown. Adjust each nut until the mating flange makes the post sit vertically. You may want to work with the



lower post separated from the electronics enclosure until it is vertical and secure. Use a small machinist's level to check that everything is plumb before affixing the system.

Drive one or more ground rods nearby and electrically tie them to the post via #6 AWG copper and suitable clamps. Use anti-corrosion grease on these joints.

Before tightening down the three head sensor assembly screws, orient the head to point towards the least likely direction of the prevailing wind as shown in Figure 7 on page 2-5. The general idea is to try to statistically minimize the time that the wind is arriving in the direction of the sensor arm to minimize turbulence.

**Important:** Avoid rotating the sensor assembly more than 90 degrees about the vertical axis, as this stresses the wiring harness. Instead, use the mounting flange to roughly orient the arm and perform a fine adjustment by rotating the head.

### Aim the head and level the plates

Once you have aimed the sensor assembly, use a bubble level verify in both north/south and east/west planes that both the top plate and the solar sensor are level. Make any necessary adjustments to the three sensor head adjustment screws, secure all three sensor assembly adjustment screws by hand, and re-verify level. *Do not over-tighten the three screws, as they are aluminum threads.*

Verify both solar/IR sensors and top plates are level north/south and east/west

Temperature probe extended and white solar shield in proper position

Three adjustment and retaining screws



Figure 13. Ensure the ambient temperature sensor probe is extended, the white shield is positioned as shown, and top plate and solar/IR sensors are both level.

Accurate air temperature is required by the internal algorithm, and the temperature probe is shaded from sunlight for accurate measurements. Verify that the external probe is partially extended from the strain relief and is fully shaded by its white sun shade (see also Figure 21 on page 4-7.)

The height of the sensor plate above ground depends on your site's maximum anticipated snow accumulation depth, which can vary significantly on a seasonal basis. The top sensor plate should sit at least from 1.5-2m above the height of the maximum anticipated snow accumulation depth. If you routinely receive snow over 1m deep, you may want to mount the system plates at 2-3m, by using a taller support post. Note that the sides of the electronics enclosure must remain

exposed to the wind to ensure proper cooling of the electronics during periods of very heavy precipitation when it is working the hardest to maintain elevated plate temperatures.



Figure 14. Temperature sensor should protrude under solar radiation shield.

If you expect large wild or domesticated animals in the area such as bear, elk, deer or farm animals such as horses or cattle, they might try to use the system enclosure as a scratching post and this will exert strong overturning forces. Especially out on open cattle range land we recommend fencing in the system in to prevent animals from reaching it.

In summary, the system's mechanical support post must be mechanically stable in the presence of all incident wind and be located away from any nearby object that could create downwind turbulence.



## Lighting Protection Considerations

Sensitive electronic environmental measurement systems require careful attention in order to prevent them from being severely damaged or destroyed by lighting. Most outdoor installations will necessarily be in open or elevated areas that are prone to lighting including open fields, rooftops and tall met towers.

Cloud-to-ground lighting strikes create temporary electrostatic field wave that propagates for hundreds of meters in all directions away from the strike location. Along the surface this wave elevates the potential of ground to several hundred or sometimes several thousand volts, for several hundred nanoseconds. This energy is inductively coupled into buried power or communication wiring in the area. The coupled energy is then transmitted long distances via the low impedance wiring to sensitive equipment at the far remote end causing breakdown voltages to be exceeded in semiconductor equipment and permanent damage. The power and data communications wiring effectively act as antennae. Especially with nearby ground strikes, huge amounts of energy can be coupled from the ground shift, and if currents exceed the maximum input voltage of the semiconductors used in the interface electronics they will be permanently damaged. To mitigate these risks, the following protection is strongly advised at installation:

### Recommended Lightning Protection Techniques

- Optical isolation eliminates inductive pickup between wires acting as antennas; if you select the RS-232 serial interface or 802.3 Ethernet, use fiber optic cable technology.
- Avoid lengths of non-metallic conduit encasing wiring between the instrument and the power feed or your network end point. If you decide to use copper communications wiring, encase it in metallic conduit and surge protect the cable *at both ends*.
- If you must use the analog pulse output, MOV surge protect both ends, use shielded cables and encase the wire in buried metal conduit.
- For the AC line install both whole house *metal oxide varistor* (MOV) type protector and a Square-D “spark gap” type protector inside the AC outlet feed located directly under the system. Note MOVs are sold in various Joule ratings and are made by Intermatic (IG1240RC), Leviton (51120-1), Panamax (gpp8005) as well as GE and Siemens (various models).
- Install a second pair of identical devices at the service panel feeding the system outlet. A solid state MOV will activate and clamp a spike in nanoseconds, while the spark gap will takes over before the maximum number of Joules the MOV can possibly absorb is exceeded, protecting it.
- Ground the AC outlet to its own local ground rod located immediately under the instrument. Connect the green enclosure ground wire hanging from the enclosure to your building’s lighting protection ground, or a second ground rod located beneath the instrument (however, avoid connecting AC ground to this second ground rod.) The use of two rods provides a low impedance path to ground from the MOV/spark gap combination.



- An online type Uninterruptible Power Supply is helpful to isolate incoming line transients from the AC grid. However, it must be physically protected from the elements (no ambient temperature swings or condensing humidity environments). It should ideally be physically located somewhat close to the system to be effective in absorbing line transients.

Following the above best-practice guidelines will greatly help your system avoid lightning damage during its lifetime.

## Wiring the System

The system is shipped prewired with the communication options you ordered. The serial port output either streams data on a fixed, periodic schedule or output in response to a request command at the serial port. Real time data records consist of a timestamp, measured precipitation rate ( $\text{mm hr}^{-1}$ ), accumulated precipitation (in mm), ambient temperature (in  $^{\circ}\text{C}$ ), calculated wind speed (in  $\text{ms}^{-1}$ ), solar radiation, thermal infrared, air pressure, relative humidity and error status, as well as a calculated CRC checksum. In addition to displaying real time data, *TPS-Manager* can store ASCII data to a disk file for archival or later study. To setup and install *TPS Manager* run *setup* on the CDROM, or download the latest version here:

<ftp://support.yesinc.com/software/tps-3100/>

### Communications Wiring

A tethered cable is supplied connected to the electronics enclosure. The system is configured by the factory to use one of the following methods:

- 9 pin D-sub cable for direct connection to a PC serial port, or
- RJ-45 Ethernet cable (serial-to-Ethernet option) for 802.3 TCP/IP, or
- ST fiber optic cable (serial-to-Ethernet and fiber option) for isolated connection to your LAN hub, providing true galvanometric isolation.

The latter two methods use TCP/IP communications over your LAN infrastructure via COM port redirector technology, described in *Installing the Serial-to-Ethernet COM Redirector* on page 2-22. Note while 802.3 Ethernet provides transformer isolation, the use of optical isolation is strongly advised to protect the system or your networking equipment from lighting damage

The system digital RS-232 serial data communication port uses a simple three wire interface without hardware handshaking. To extend the reach of the supplied standard cable beyond the maximum 50' distance in the EIA RS-232C specification, serial-to-Ethernet (10/100BaseT RJ-45 interface) options enable TCP/IP LAN communications, with optional fiber optic adapters.

### Using Dial-up (V.9X) Hayes Modems

---

If you are not worried about telecommunications charges or on a campus wide Private Branch Exchange Plain Old Telephone Service (POTS) dial up modems enable remote access via the existing telephone network. The cellular network can also provide connectivity via GSM data modems made by Siemens and others, if you avoid streaming mode or use *TPS-Manager*. For a dial up modem, you first manually program the modem to answer after one ring using a terminal emulator and suitable cable. Verify that the modem is offline mode by typing:

```
AT <enter>
```

Assuming Verbose mode is not active you see the acknowledgement: OK

With the modem now offline, type the following Hayes-AT commands that program the modem

- to not be verbose,
- to not echo,
- to answer an incoming call after one ring and
- to store the setup in both non-volatile memory locations

Note the “0” shown are zeros and not letters:

```
ATV0
```

```
ATE0
```

```
ATSO=1 <enter>
```

```
AT&W0 <enter>
```

```
AT&W1 <enter>
```

For more detail see the section Communications Connection on page 2-21.

## Making the Electrical Connections

---

With the system mechanically level and secure, you can proceed to connecting the AC power supply and RS-232 communications link to with your data management system.

The following sections explain how to connect the system to:

- AC power line
- Safety Ground
- RS-232 serial link or 802.3 Ethernet LAN, or
- Pulse output to an analog data logger, such as a Yankee Environmental Systems [Model YESDAS-2](#)

**Caution:** There are lethal voltages inside the system, and no work should be performed on it while it is connected to AC line power - always disconnect AC line power before servicing the system. Only operators familiar with the detailed operation of the system should be allowed to maintain it, and all servicing is to be performed by qualified, technically trained personnel only. Note the system does not automatically-switch between 100-240 Vac! It was setup for your regional voltage based on the ship to address on the sales order. If need to move it to another region, verify that the internal AC line voltage switch is set to the proper position before applying power (see Figure 23). Also, avoid connecting the RS-232 data ground to the AC power ground. Instead, connect it to a local ground rod driven into the earth below the system. Tie the support mast to the ground rod for safety protection, and use anti-corrosion grease at all exposed ground connections.

For the system electrical safety ground, a customer-supplied ground rod driven into the earth, or a buried ground mesh net is required. If it will be mounted on a flat roof, a connection to the lighting rod system is highly recommended. Unless you are using the serial-fiber Ethernet option, isolate low voltage communications wiring from AC wiring.

When running cables setup drip loops such that water drains away from cable entry points. Avoid in-line cable connectors or exposed splices; instead use a run of new cable. All cables should be secured tied off to minimize repeated motion from wind, which can cause them to work harden and ultimately fail.

## AC line power connection

---

You can plug the AC power cord into an outdoor outlet with a “code-keeper” weatherproof outlet cover to keep water out. You can also cut the cord plug and feed it into Seal-tite armored conduit for direct connection to a junction box.

The AC line cord provides system power and is typically plugged into a weatherproof outlet box. Use an in use weather cover/lid, or hardwire the cord into a junction/distribution box. For permanent installations the plug can be cut and the cord encased by a customer-supplied flexible Seal-tite PVC conduit fed by a junction box.

**Important:** Inside the enclosure, the AC cord terminates at a terminal strip. The electronics enclosure must remain sealed and should not be opened unless absolutely necessary, and *never during periods of precipitation!* See the detailed procedure for accessing the enclosure in Accessing Internal Components on 4-4. Try to resist the temptation to open the electronics enclosure, as the door must remain tightly sealed to keep precipitation out of the internal electronics.

The system is designed to operate continuously with power on and this helps to keep moisture out of the electronics. This implies that the door must be carefully resealed if you have to open it. Exposure to the weather while powered off may damage the system electronics as water vapor may penetrate it and void your warranty. If you decide to leave it powered off for an extended period relocate the system inside. See page 2-2.

## Wild Animals and Lightning Protection

In rural areas where you anticipate wild animals attacking and chewing on cords (e.g. wolves or coyotes), it is best practice to protect the cables by using a suitable armored cable such as Seal-tite, or equivalent. Although electrical code may require the use of a ground fault circuit interrupter (GFCI), we recommend you avoid GFCIs as they suffer from false tripping due to nearby lightning-generated noise. Instead, use a traditional circuit breaker and install commercial grade spark gap and Metal Oxide Varistor (MOV) lightning surge suppression on the AC outlet circuit. Most electrical supply houses can provide you with dual mode protection devices, manufactured by Leviton and Square-D. This underscores the need to install a system safety ground.



Figure 15. An example of how accumulated winter ice on exposed, unprotected wiring and cables can cause problems. Armored conduit protects wires from ice damage as well as hungry wild animals who chew on them.

## **Safety Ground: Connecting to Earth Ground**

---

While nothing can protect equipment against a ferocious direct lightning strike, the odds are excellent that a nearby strike will occur during the life of the system. When lightning hits the surface of the Earth, a current pulse travels outward in all directions for hundreds of meters away from the ground strike. This wave effectively creates a large shift in the potential reference that we think of as “ground.” Because of corrosion in buried ground wiring and water pipes, a typical AC electrical ground in rural areas may exceed hundreds or thousands of Ohms impedance to what is “true” ground. If this ground potential shifts more



than  $\approx 30V$  during a cloud-to-ground strike, permanent damage can occur to semiconductor devices within the system. The main RS-232 interface IC is socketed on the internal PCB in case it suffers static damage, but a safety ground system is paramount to maintaining the system at ground and preventing damage to the control electronics. Because of this, do not skip installing a safety ground for the system, as lightning will potentially destroy it!

To help prevent damage in case of a lightning strike, you must connect the support post to a ground rod or a buried ground mesh. Tie ground to one or more copper-clad ground rods, each driven in the soil beneath where you are installing the system. If the system is installed on a roof and there is a already rooftop lightning rod system, tie it electrically to that system. If no roof lightning ground system is available, locate the nearest copper cold water supply line and using a suitable clamp, tie into it. At a minimum, connect to the building's steel frame or metal roofing. A shorter ground wire will lower the system impedance, providing better protection. Drive two ground rods at least eight feet in the ground and clamp them using anti-corrosion grease.

**Caution:** Connect the post to a local ground rod, not the AC third prong!

In extremely dry (sandy) or rocky soils, such as prairie fields or atop mountains, ground conductivity is poor and driven ground rods are not feasible. In order to obtain adequate lightning protection you must build a buried subsurface *ground screen* to create a plane as a radial mesh. Secure several pieces of #6 AWG copper wire and bury it in a radial or mesh pattern, buried with soil as deep as possible. This will create a *ground screen* that substitutes for a ground rod.

To build a ground screen as seen in Figure 16, tie the ground wire to one or more copper-clad ground rods, each driven in the soil immediately below where you are setting up the system. In sandy, or rocky soil areas or at mountain top sites, you may need to put the ground rods at a steep angle and bury multiple wires in a radial pattern, using eight or more ground radial wires. Place the wires equally around the site near the surface and cover them with topsoil. For below grade connections use thermal fusion weld splices to bond the wires together before burying them.

## Ground Screen

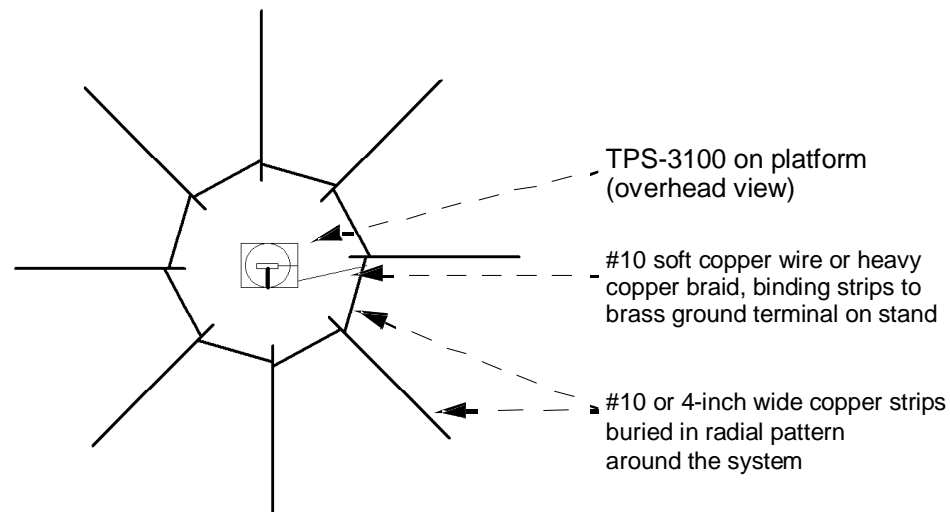

Figure 16. Radial ground wire pattern used in rocky soil applications. Bury each radial as deep as you can—if the area is solid rock, the radius should be at least 10 m. Tie the far ends of all radial together using a large circle of wire. Use thermal fusion welds on all below grade wire junctions to avoid corrosion.

**Note:** The warranty does not cover damage resulting from lightning strikes, which can seriously damage the system electronics. Power surges are common on rural power mains. Do not omit AC power surge protection!

Instrument sites are often the highest point in a field, making them targets for lightning. If possible, as an extra precaution, set up an array of aerial whip lightning rods that are tied to the buried ground screen to dissipate an electrical field and provide an adequate path to ground should lightning strike nearby. Be sure to keep the tips of the aerials level or below the instrument's field-of-view. This technique is used worldwide at power transformer distribution stations. You can use radio antennas as the lightning rods; and note that sharp points tend to improve the effectiveness.

Attach the system support post to the ground system via a copper wire using anti-corrosion grease and fusion splices. The shorter you can make the ground wire, the better the ground will work. For data communications, it is vital to use foil-shielded wiring as cables act like antennas and can pick up lightning energy and bring it into the system. The goal is to provide a metal cage that provides a low impedance path to ground or a ground screen, to enable lightning energy to bypass the system electronics.

**Important:** Avoid directly connecting the AC power ground to the lighting ground system. Cross-connections often exhibit a slight differential voltage vs. AC ground and will significantly chemically corrode wiring, eventually leading to an open circuit condition.

To help protect against lightning damage entering via the AC line, it is best practice to provide surge protection by adding both MOVs and spark gap devices permanently wired at the mains junction box. These commercial electrical protection devices are made by vendors including Square-D and Intermatic and

are distributed by commercial electrical supply vendors (e.g. Grainger), typically as “whole house protection” devices. These devices are wired in parallel with the AC input line in a NEMA-4X waterproof enclosure intended for use in wet outdoor locations.

## Operating Away from AC Grid Power

While we do not recommend it, the system runs internally of 52V and can operate transiently via a bank of solar charged batteries. However, the system draws  $\approx 100W$  continuously at idle with no wind or precipitation. In worst case conditions of high wind, low temperature and heavy precipitation it can draw up to 680 Watts. At remote off grid sites, four solar panels+batteries in series (about 54 Vdc at full charge), controlled by a co-located YES Opti-Grid switch powers on only during periods of precipitation.

### Remote Off-Grid Operation

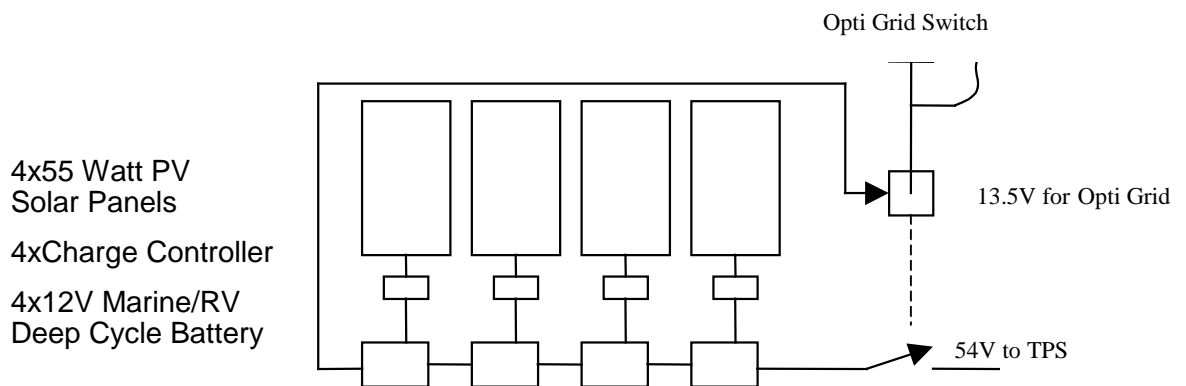

Figure 17. Solar powered configuration.

## Communications Connection

The standard system digital serial data link interface is a conventional 9 pin EIA-RS232C serial communications port. (If you have the optional fiber or Ethernet interface you can skip to the section below). While the EIA RS-232C specification has a 50' ( $\approx 15m$ ) limitation on cable length, in practice if you use high quality, low capacitance-per-foot cable you can extend this limit up to about 200'. However, keep in mind that long wires outside are essentially antennas and *there is always the significant risk of permanent lightning damage to your system!* If you must use a long cable, be sure to put it in metal conduit or locate all of it within the shell of a building.

**DB-9F is a DCE device**

**Use fiber optic media converters**

For runs of just a few feet, you can direct wire the system assuming you provide RS-232 surge suppression at the remote end of the serial cable. However, best practice to protect your investment from lightning damage is to use fiber optic media converters to provide true electrical galvanometric isolation. Another option is RS-422, which enables separation up to 4000 ft ( $\approx 1300 m$ ); fiber optic links can be much longer. For RS-422 select media converters that provide true optical isolation. Fiber optic and isolated RS-422 media converters are sold by [B&B Electronics](#) and [Black Box](#) to adapt the system RS-232 port. While RS-422 allows the use of less expensive wire, we strongly recommend the use of the serial-to-fiber interface option. Media converters require a source of power, and

do not forget the AC power supply feeding the media converter needs its own lightning surge protection.

If your PC lacks a RS-232 port, you can use a serial-USB converter from a number of vendors, including [www.Belkin.com](http://www.Belkin.com). Note that some third party media adapters draw power from RS-232 hardware flow control lines. On the PC end this will work, however, as flow control lines are not implemented on the system and a separate power supply is required. It is good practice to plug the media adapter's DC power supply into a Metal Oxide Varistor type outlet protector to provide lightning surge protection.

Assuming you will observe the data using *TPS Manager*, simply plug the supplied cable into an available COM port your PC.

## Serial-to-Ethernet Option

### Installing the Serial-to-Ethernet COM Redirector

The COM port redirector used by the serial-to-Ethernet or serial-to-fiber adapter options requires two steps before you can use it with *TPS Manager* or your terminal emulator:

- Use *Device Installer* to assign the TCP/IP settings to the hardware
- Install the COM port redirector software driver on your PC

Essentially, a COM redirector sets up a virtual COM<sub>n</sub> port providing a serial port to MS-Windows applications, via TCP/IP networking. The *Device Installer* program assigns a valid TCP/IP address for the hardware redirector that is typically fixed and selected to be compatible with your LAN's netmask. Once installed, the PC "thinks the serial port is direct connected" while TCP/IP packets are actually sent over the 802.3 LAN to the interface hardware. For reliability, avoid dynamic addresses (DHCP); instead, use a static address compatible with your LAN, netmask and gateway. You can read more about COM port redirector technology at: <http://www.lantronix.com/device-networking/utilities-tools/com-port-redirector.html>

1. It is always a good idea to record how your TCP/IP settings are configured for the various interfaces on the PC. Start a Command prompt and type:

```
ipconfig /all
```

2. A Quick Start guide is located here:

[http://www.lantronix.com/pdf/UDS1100\\_QS.pdf](http://www.lantronix.com/pdf/UDS1100_QS.pdf)

And a discussion of networking features here:

[http://www.lantronix.com/pdf/UDS1100-B\\_PB.pdf](http://www.lantronix.com/pdf/UDS1100-B_PB.pdf)

3. Insert the CD-ROM and follow the directions to install Device Installer. Or, you can download the latest version at either of the following locaitons:

<http://www.lantronix.com/device-networking/utilities-tools/device-installer.html>

or <http://support.yesinc.com>

Web help for Device Installer is available from:

<http://www.lantronix.com/ftp/DeviceInstaller/Lantronix/4.3/4.3.0.1/Help/Web/Default.htm> or

<http://www.lantronix.com/support/webhelp/device-installer/DeviceInstaller.htm>

4. The COM Driver User's Guide is here:

[http://www.lantronix.com/pdf/DeviceInstaller\\_UG.pdf](http://www.lantronix.com/pdf/DeviceInstaller_UG.pdf)

And for reference, the Hardware User Guide is here:

[http://www.lantronix.com/pdf/UDS1100\\_UG.pdf](http://www.lantronix.com/pdf/UDS1100_UG.pdf)

**Note:** Due to the many network configurations in use around the world it is not possible for us to provide technical support for configuring the COM redirector. Consult your Network Admin/MIS staff to obtain valid settings for a fixed IP address, netmask and gateway appropriate for your LAN. If you send these settings with your factory at time of order, we can set them such that you can simply connect it. If you require help with configuring the TCP/IP settings, please direct your local Network Admin or PC support specialist at the links on this page.



## Hardware Connection to Data Management Systems

This section is written specifically to assist systems integrators with setting up a permanent communications interface with a Data Management System (DMS), Programmable Logic Controller (PLC) or analog data logger equipped with a RS-232 serial port. If you are using the system with *TPS Manager*, you can skip this section.

For nearly all commercial weather stations the system will be directly wired to your DMS, logger or PLC collection device. You will program your device to either poll data on demand, or enable it to ingest streamed ASCII data from the system. This section focuses on configuring *hardware communications wiring* between the system and your DMS; see Understanding the Command Line Interface on page 3-2 for guidance on programming your DMS to interact with the system via ASCII commands. Once the system is properly wired and connected you will need to configure the serial port on your DMS, PLC or data logger to capture and store all ASCII strings the system produces at 8-N-1, 9600, and then transmit them to a remote data buffer or store them in a data file. Exactly how to do this depends on you're the design of your hardware, please refer to its documentation for more details.

**Important:** Prior to permanent field deployment, we recommend thoroughly testing the integration to verify that the data interface responds properly to all possible instrument states. We strongly recommend you implement CRC checking of ASCII data to continuously verify no communications errors occur.

The system serial port is setup as a three wire (Transmit /Receive/Ground), female DB-9 connector *Data Communications Equipment* (DCE) device. Unless you ordered the serial-to-Ethernet or serial-fiber option, the supplied tethered serial cable is direct/straight wired and is configured to plug directly into one of your PC's available Data Terminal Equipment (DTE) male DB-9serial (COM) ports. If you need to extend this cable, be sure to protect junctions or splices from the weather using suitable waterproofing methods. DB-9 connectors are not suitable for continuous outside use or exposure to the elements and you must protect them from moisture. If your PC lacks an available serial port, can use a serial-to-USB adapter, available from Belkin and others.

When wiring directly to a DMS that has a serial port setup as DCE rather than DTE, you must configure a "null modem" adapter or wire the cable to exchange the two TXD and RXD wires; this enables a successful DCE-DCE connection.

**Note:** RS-232 cables come in many shapes and styles. Even if the cable connector physically mates, you cannot assume the electrical connection is properly wired. Most RS-232 problems are caused by incorrect cable wiring or lack of a null modem when one is required. If you are new to RS-232 or not sure of the interface wiring, refer to Horowitz & Hill's "The Art of Electronics" ISBN: 0521370957; 3rd edition, for a tutorial on RS-232.

Test using *TPC-Manager* or your favorite terminal emulator; as there is only one serial port, simultaneous use with *TPS-Manager* and your DMS is not possible.



**Note:** If you are sure the cable is wired correctly but see no response on your terminal emulator, first verify that you have the baud rate set correctly, next that you do not have software (XON/XOFF) or hardware flow control enabled (“hardware handshaking”). For example, on *Hyperterm*, set flow control to “none” and verify you are “on line.” Finally, if this still does not work, revert back to testing using a known working serial cable, such as the one shipped with the system.

---

## Preliminary Checkout

As a simple functionality test of communications, after the system is powered on and the 10 minute initial warm up delay has elapsed (view Fault/status bits), squirt a few drops of water via a handheld water spray bottle onto the top plate, where the water drops are close to the ambient temperature. After a minute or so elapses you should begin to observe a change in output records, which will look similar to Figure 22 on page 4-9.

Note to display data in real time via your own DMS, PLC or data logger, you will need to parse the system output records (text strings) following conventions described in Understanding the Command Line Interface on page 3-2.



# Configuring the Pulse Accumulation Output

The pulse accumulator output interface supports integration with simple PLCs or analog data loggers that only have pulse counting inputs.

**Note:** The pulse output is provided as a convenience, but in almost all applications the RS-232 serial interface is recommended because the pulse output provides only accumulated precipitation. For the most accurate measurements we strongly recommend that you use the digital RS-232 serial port interface, simply because it provides far more information to the end user as well as indicating serious system problems. The serial port provides time/date, instantaneous precipitation rate, ambient temperature, air pressure, humidity, visible/NIR solar radiation long wave thermal infrared radiation, internal chassis temperature and system diagnostics status.

The pulse output interface is an open-collector type digital output that is wired to data loggers equipped with analog or pulse accumulator inputs, such as a YES Model [YESDAS-2 Data Acquisition System](#). Use good quality foil-shielded cable between the systems and connect the shield to the local ground rod.

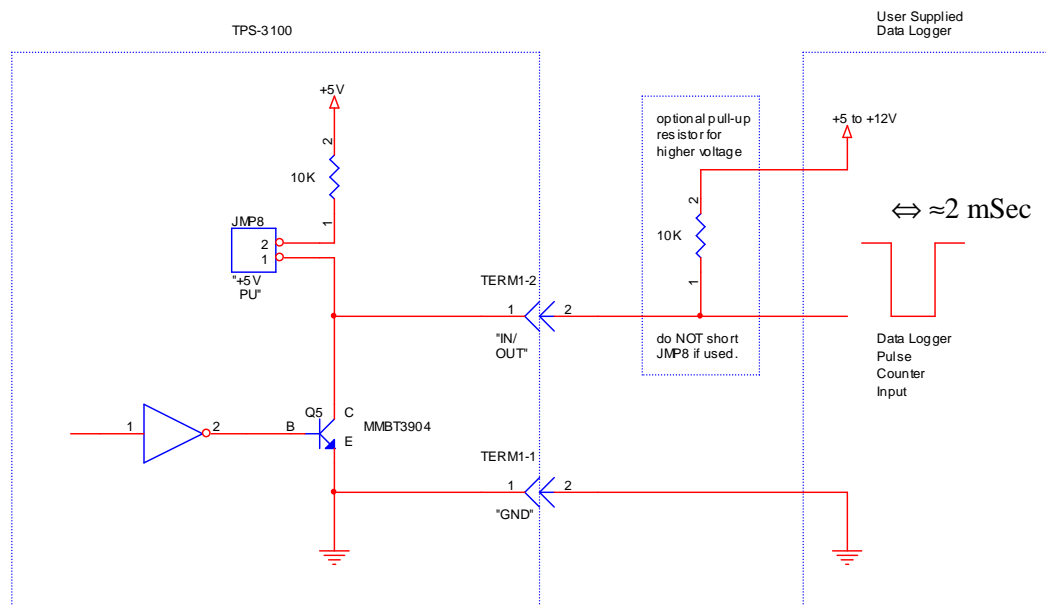

Figure 18. TTL pulse output interface circuit. The pulse output goes low for about two mSec to indicate accumulated precipitation.

In contrast to instantaneous rate provided by the serial interface, each pulse represents *total precipitation*, emulating a tipping bucket rain gauge. You must program your logger device to count pulses, which can usually be mathematically integrated by logger software. For each pulse the default value of pulse-per-unit-precipitation is 0.01". Note the default value is user-settable in units of microns via the serial port's *B* command.



**Important:** There are a wide variety of analog interfaces in use today and internally, the pulse accumulation output is setup as an open-collector type with a *pull-up* resistor that sets the voltage range desired at the logger.

For example, suppose you want a range of 0-5Vdc. In this case, you will leave the default jumper installed at JMP8. However, if you wanted another voltage (e.g. 0-3V), you should remove the jumper and add a 10K $\Omega$  pull up resistor, located at your data logger's pulse input. You will need to excite the other end of this resistor with a stable DC excitation voltage, typically provided by your data logger's power supply (e.g. 3V). Note that if you remove JMP-8 and no pull up resistor is present in the circuit, the pulse output interface will not work.

# CHAPTER 3

## Using the System

---

This chapter is aimed at systems integrators who need to understand the ASCII messages the system produces and is intended for customers wishing to integrate the system to a data management system (DMS). It assumes you have successfully wired and tested communications to the system as described in the previous chapter. If you are using the *TPS Manager* application or are using the pulse output, you can skip this chapter.

Topic	Page
• Understanding the Command Line Interface	3-2
• Output Data Record Formats	3-4
• Interactive vs. Streaming Data Output Mode	3-8
• Resetting the Accumulator	3-10
• Using Tipping Bucket Mode	3-13
• Interpreting Fault Event Codes and Status LEDs	3-15
• Detecting Blowing Snow with Dual Systems	1-8

The system is typically connected to AC power and run continuously. It can be used with TPC-manager or permanently wired to your DMS either via direct serial data cable, POTS dialup modems or via serial-to-Ethernet TCP/IP interface options.

Due to the wide variety of data loggers and DMS in use around the world, we cannot provide custom integration support. Unless you have adequate programming experience with precisely how your particular DMS system ingests and processes serial ASCII data, we strongly recommend that you solicit the help of a trained systems integrator to link the system to your DMS.



# Understanding the Command Line Interface

Once the system has passed its ten-minute start up period, you can interact with it by its command line interface (CLI). The CLI uses the RS-232C serial port and supports two types of commands:

- *query* commands, and
- *edit* commands

Query commands consist of a single character, and are used to display instrument data. Edit commands always begin with a '/' character, and are used to modify the instrument's behavior by setting system parameters in the internal system memory.

## Run vs. Edit Mode

Whenever the system is powered on, the default CLI state is in *run* mode, whereupon any of the query commands, as described below, can be executed. Entering the '/' (forward slash character) will cause the interface to change into *edit* mode, which allows parameters to be modified. Once edit mode is initiated, if no further keystrokes are entered within 10 seconds the interface will automatically revert back to run mode.

**Note:** Even when the user interface is in edit mode, the instrument is still measuring precipitation and operating as normal, and the interface implements a type-ahead buffer to avoid buffer overruns. This functionality enables the instrument to be controlled by a completely automated control system.

## Command Syntax

Command input is always *case-insensitive*, i.e., a 't' is equivalent to a 'T'. Upper-case commands will be used in this document for the sake of clarity. In situations where numeric input is required, the <Enter> key is used to execute the command, hitting the <Esc> key will cause the command to be aborted.

Note many commands are paired, one to display a particular type of information, another to modify it. For example, the 'C' command is used to *display* the current time, whereas the '/C' command is used to *set* the current time.

## Power on banner

The system serial port outputs a four-line banner when powered on, indicating model, and firmware version. An example might look like:

```
YANKEE ENVIRONMENTAL SYSTEMS
TPS-3100 TOTAL PRECIPITATION SENSOR
Firmware v2.3 02/14/2005
SN 050102, PCB 0501021, HEAD 0501021
```

The banner indicates the manufacturer, model number, product name, firmware revision and date as well as serial number of the system (SN), Printed Circuit Board (PCB) version as and sensor head serial number. This power on banner string can be parsed to yield potentially useful information for managing network data quality, as each head is individually-calibrated.

It can also be used to automatically detect AC power cycling at remote sites, assuming that networking begins to function immediately, once power returns. Serial numbers can automatically identify data streams from sites and to discover



system swaps due to site maintenance. CLI commands are described in the sections that follow.

**Note:** When the system is first powered on, there is an automatic 10-minute warm-up period, which the status field indicates via a status code of all ones, permitting remote indication of unintended power cycling events. This warm-up period is necessary to allow the system to reach thermal equilibrium with the environment to maintain measurement precision. During the warm-up period the status LED glows a steady red, and no precipitation results are indicated at interfaces, regardless of present conditions.

# Output Data Record Formats

The Transmit command, invoked by typing a 'T', is the most commonly used CLI function and returns the current measurement data. The 'T' command is echoed, followed by a space, and fields are separated by commas. All fields are fixed length, padded with zeros as necessary. An asterisk (\*) always separates the last field from the CRC value unique to that string (see below). The line is terminated with a carriage-return and linefeed (<CRLF>) sequence.

A typical output example is shown below, followed by field definitions:

```
T 002,0000000,1279727615,03.07,00001.49,025.1,034.8,07.1,0472,-127,
1012.6,024.3,51.4,03*D5C7
```

FIELD	DESCRIPTION (UNITS)	FORMAT
002	Output format version (v.001 has no aux met)	ddd
0000000	Fault indicator (described on page 3-15)	bbbbbbb
1279727615	Timestamp in seconds since 1/1/1970	ddddddddd
03.07	Current precipitation rate (mm/hour)	dd.dd
00001.49	Total accumulated liquid precipitation (mm)	dddd.dd
025.1	Ambient temperature (°C)	sdd.d
034.8	Instrument enclosure temperature (°C)	sdd.d
07.1	Wind speed (meters/second)	dd.d
0472	Solar Radiation [W/m <sup>2</sup> ]	dddd
-127	IR net radiation, sky to ground [W/m <sup>2</sup> ]	dddd
1012.6	Barometric pressure, referenced to sea level	dddd
024.3	[mbar] <sup>1</sup>	ddd.d
51.4	Temperature of relative humidity sensor [°C]	dd.d
03	Relative humidity [%]	dd
(not present)	Tipping bucket input [mm] <sup>2</sup>	dd
D5C7	CRC checksum (described below)	hhhh

<sup>1</sup> if sensor not installed pressure returns fixed as the standard atmosphere; 1013.25 mbar.

<sup>2</sup> included only if system configured for tipping bucket *input* (default is tipping bucket *output*).

## CRC for Commands

### Checking ASCII Strings Against the Checksum

Every data record is followed by a generated mathematical checksum via a *cyclical redundancy check* (CRC). You can ignore the CRC, but it is good engineering practice to provide software that automatically verifies each data record string has not been corrupted by the communication link between the system and your DMS. Professional installations always use a calculated CRC value as a way to reliably verify end-to-end communications data link integrity.

You will write code to compute a CRC value from each returned command string and compare it to the unique ASCII CRC value the system appended at the end of each data record. If your result differs from the record string, you can assume there was a communications error and discard the data record. Usually, in this case you will repeat the same command and try again.

**Note:** There are several common algorithms used to compute CRCs; the system computes a CRC checksum as defined by the “CRC-16” standard as a 16-bit checksum based on the polynomial:

$$x^{16} + x^{15} + x^2 + 1$$

This polynomial corresponds to the hexadecimal value 8005. The CRC value is in hexadecimal format, calculated least-significant bit first, initialized to zero, Note that the CRC checksum does not cover the echoed T command, nor the following space, nor does it cover the asterisk separating the data from the CRC value itself. For more details, see *Numerical Recipes in C*, by Cambridge University Press.



## Setting the Real Time Clock and Time Zone

The system contains a real-time clock (RTC) that time stamps all data records, and which is used to periodically reset the accumulated precipitation counter.

The RTC may either be set to local time or UTC (universal coordinated time) according to user preference. If UTC is used, a time zone offset may be specified such that local time can be calculated. For example, this design enables the instrument to optionally reset the accumulated precipitation counter at local (as opposed to UTC) midnight.

**Caution:** Altering system time only changes time stamp output, however, altering this output will likely propagate errors in real time downstream integration calculations if it is one casually. It is thus generally advisable that altering system time should be avoided when high measurement accuracy is desired. Unless you have a single site, we recommend standardizing on GMT to enable unambiguous cross-time zone time to simplify your network operations.

In addition to the time being displayed in “Seconds Since 1/1/1970” format by the Transmit command, it may also be displayed in human-readable format by the ‘C’ command. Sample output from this command is shown below:

### Displaying Time/Date

```
C 2004/12/20 21:22:47
```

The ‘C’ command is echoed, followed by a space. The date and time are then displayed in year/month/day hour:minute:second format, and the line is terminated with a carriage-return and linefeed (<CRLF>) sequence.

**Note:** The system always uses 24-hour time format. If the internal PCB-mounted type 2032 coin type 3V lithium battery becomes discharged and AC power is lost, the clock will stop and will require a reset. You may wish to detect this condition automatically in your DMS

The date/time is set via the companion ‘/C’ edit command. A sample of the command format is shown below:

### Setting Time/Date

```
/C YYMMDDhhmmss  
041220163810
```

The ‘/C’ command is echoed, followed by a space. You are then prompted with the format of the date-time string: year, month, day, hours, minutes, and seconds. Note that only a two-digit year may be specified, and no punctuation is allowed.

- Use the <Backspace> key to make any corrections necessary.
- Press the <Enter> key to update the system clock.
- Press the <Esc> key to abort the changes.
- Note that any trailing characters left unspecified will default to zero.





## Setting the Time Zone

Similarly, the time zone offset may be displayed and modified. The ‘**z**’ command is used to display the current time zone information. A sample of the output is shown below:

```
z +00:00
```

The ‘**z**’ command is echoed, followed by a space. The time zone offset is then displayed with a sign (+/-) character followed by hour:minute format. Note that positive (+) offsets would be used in the Eastern Hemisphere, negative (-) offsets would be used in the Western Hemisphere. The line is terminated with a carriage-return and linefeed (<CRLF>) sequence.

The time zone offset may be set with the companion ‘**/z**’ command. A sample of the command format is shown below:

```
/z SHHMM  
-0500
```

The ‘**/z**’ command is echoed, followed by a space. You are prompted with the format of a time zone offset string: sign, hours minutes. The sign may be a plus (+) or minus (-) sign, or it may be left blank. In this example, the time zone offset is set for Eastern Standard time, -5 hours. Use the <Backspace> key to make any corrections necessary. Press the <Enter> key to update the time zone offset. Press the <Esc> key to abort the changes. Note that any trailing characters left unspecified will default to zero.



## Interactive vs. Streaming Data Output Mode

To provide flexibility in interfacing with a variety of data management and collection systems the system serial port has two basic output modes: *interactive* or *streaming*. In the request-acknowledge *interactive* mode, you send a **T** command to the system on demand and the system returns one result data string (or “record”).

In *streaming* mode, the system automatically sends output data records on a predefined time schedule, as a stream of data record strings one after the other forever (or until you send it a command to stop). The scheduled streaming output interval can be set between zero and 9999 seconds. Setting the interval value back to zero disables scheduled automatic streaming output and returns the system to interactive mode.

**Caution:** Avoid using streaming mode if direct connected to a dialup V.92 modem or a GSM cellular data modem, as the data stream itself can be inadvertently misinterpreted by the modem as an escape command. This will cause the modem to lock up and never answer incoming calls. Instead, use interactive mode (or use *TPS-Manager*) and program the modem to always auto answer after one ring as described in Using Dial-up (V.9X) Hayes Modems on page 2-15.

Displaying the current streaming interval is accomplished with the ‘**L**’ Logging command. A sample of the output of this command is shown below:

### Example use of the L command

```
L 0060
```

The ‘**L**’ command is echoed, followed by a space. The streaming interval is then displayed in seconds. The line is terminated with a carriage-return and linefeed <CRLF> sequence.

The automated streaming interval may be set with the companion ‘**/L**’ command. A sample of the command format is shown below:

```
/L SSSS
```

```
1
```

The ‘**/L**’ command is echoed, followed by a space. The user is then prompted with the format, up to four decimal digits. In this example, the streaming output interval is set to one, which will cause a data record to be sent once per second (this is the fastest output mode possible).

**Note:** Interactive mode is always enabled as default, regardless of the streaming interval. However, because modems cannot answer incoming calls if serial data is streaming into their data ports, avoid streaming mode if you communicate via a dialup modem. The four-line power on banner is always sent at power on, and modems will ignore calls during this brief power on period.



**Caution:** If you set the streaming interval to less than 15 seconds and then accidentally enter streaming mode while a dialup modem is online, thereafter the modem may never again answer an incoming call, and you will be permanently locked out of the system. Power-cycling will not change this state; to reset the system back into interactive mode you must physically visit the system, disconnect the modem and use a terminal emulator to reset it to interactive mode.

Basic command usage and behavior:

- Use the **<Backspace>** key to make any corrections necessary
- Press the **<Enter>** key to update the automatic streaming interval
- Press the **<Esc>** key to abort the changes
- Pressing the **<Enter>** key without entering a value will be interpreted the same as entering zero, i.e., automatic streaming output will be disabled
- Even when using the CRC checksum to verify data link integrity, it is generally a good programming practice to verify edit commands are successful. To do this, after each edit command issue the corresponding query command to verify that the parameter has actually changed.

## Resetting the Accumulator

### Resetting the Accumulator

The instrument records the total amount of liquid precipitation measured in millimeters. This counter may be reset (i.e. set to zero) via the `/R` command. An example of this command is shown below:

```
/R Reset precipitation total? (Y/N): Y  
Total reset to zero.
```

The `/R` command is echoed, followed by a space. The user is then prompted to confirm the action. Typing a `Y` will cause the accumulated total to be reset to zero, which is then confirmed to the user. Typing an `N` (or any other character) will cause the action to be aborted.

The instrument may also be programmed to reset this value to zero automatically at local midnight based on the internal real time clock (RTC). This feature may be turned on or off via the user interface. To display the status of this feature, use the `A` command:

```
A Auto Reset is OFF.
```

The `A` command is echoed, followed by a space. The current state of the Auto Reset feature is then displayed, as ON or OFF. To change the status of this feature, use the `/A` command. Subsequent executions of this command will cause the auto reset feature to toggle ON and OFF, as follows:

```
/A Auto Reset is ON.  
/A Auto Reset is OFF.
```

Note that before using the auto reset feature, you should verify both the RTC and the time zone offset are properly set.

## Entering Verbose Mode

System records may be optionally transmitted in *verbose mode*. Verbose mode adds labels to the individual fields and is far more human-readable. As with the auto reset feature described above, this feature may be toggled ON or OFF dynamically. Each time the `/V` command is issued, the verbose state toggles:

### Turning on/off Verbose mode

```
/V Verbose mode is ON.
```

```
/V Verbose mode is OFF.
```

With the verbose mode active, an example of data output might look like:

### Example of verbose mode output

```
version=001,time=1103573931,status=0000000,rain  
rate=01.32,rain total=00025.40,ambient temp=-11.4,box  
temp=008.1,wind speed=05.3*0C9B
```

**Note:** Both the field *labels* and field *data* are included in the mathematical calculation of the CRC checksum. However, as with non-verbose mode, the asterisk that precedes the checksum itself is not included in the checksum calculation.



## Setting System Elevation

The elevation setting of the instrument can provide slightly improved retrievals from the internal wind speed algorithm and can be displayed and modified. The '**E**' command is used to display the current setting of elevation. A sample of the output is shown below:

```
E 109
```

The '**E**' command is echoed, followed by a space. The elevation, in meters, is then displayed. The line is terminated with a carriage-return and linefeed (<CRLF>) sequence.

The elevation may be set with the '**/E**' command. A sample of the command format is shown below:

```
/E Enter elevation [meters]
```

```
109
```

The '**/E**' command is echoed, followed by a space. The user is then prompted for the elevation in meters. Note that elevations from -999 to 9999 (meters above sea level) will be accepted. The sign may be a plus (+) or minus (-) sign, or it may be left blank.

- Use the <Backspace> key to make any corrections necessary.
- Press the <Enter> key to update the time zone offset.
- Press the <Esc> key to abort the changes.

## Using Tipping Bucket Mode

The second terminal of the terminal strip TERM1 located on the main controller PCB is the “TB” or Tipping Bucket I/O line, can be configured in one of two ways:

- As an *output* wired to an analog input of your data logger/DMS to simulate a tipping bucket rain gauge that indicates measured precipitation, or
- As an *input* wired to a co-located tipping bucket sensor, to capture very high rain rates during downpours in warmer weather.

The **/T** command toggles the I/O pin configuration from an open collector output of bucket tips (the default state) to an input. When in input mode the pin is typically fed from a tipping bucket instrument with a momentary contact switch, as shown in Figure 18 on page 2-27.

```
/T Tipping bucket is configured for OUTPUT [default].
```

```
/T Tipping bucket configured for INPUT.
```

When set to be an output, the instrument pulls contact two of TERM1 low (active low) for 2 milliseconds for every TB.DELTA  $\mu\text{m}$  of precipitation measured. (see **/B** below for how to set the variable TB.DELTA). When set as an input, contact closures are counted and then multiplied by TBIN.DELTA, with the result displayed as a precipitation amount in millimeters via the **T** command.

### Setting Tipping Bucket Tip Amount

---

Each bucket tip corresponds to an amount of precipitation; this amount can be displayed with the ‘**B**’ command:

```
B 254
```

The ‘**B**’ command is echoed, followed by a space. The current value of the parameter TB.DELTA (in micrometers) is then displayed.

To set the amount of a bucket tip (tipping bucket configured for input) or amount of precipitation per output pulse (tipping bucket configured for output), use the ‘**/B**’ command. For example:

```
/B Enter tipping bucket amount [microns]
```

```
200
```

This sets each bucket tip to 200  $\mu\text{m}$  or 0.2 mm.

For 0.01 inch per tip, use

```
/B 254.
```

## System Reset

Sometimes it is necessary to be able perform a remote reset, which is possible via the remote reset ASCII command:

`<ctrl>-R`

Note this command is nearly identical in effect to cycling the power to the instrument as it works by interrupting the microcontroller, such that it cannot service the hardware watchdog timer. While the plates will not cool ver much, this command forces the 10 minute warm up cycle, which will stop producing any measurements until the warm up cycle completes.

**Caution:** Ideally, you should leave the system powered on continuously to provide highest calibration stability. Repeatedly resetting the system will increase calibration uncertainty, as repeated thermal expansion and contraction of the heaters may eventually lead to material failure. Avoid issuing a reset command repeatedly, as it is cycling the system through power up. Use this command with care, and beware of unintended infinite loops created by scripting errors.





## Interpreting Fault Event Codes and Status LEDs

For quality control and diagnostics purposes, you should monitor the system status. The electronics continuously watches for various hardware faults, and if detected, a *fault event code* indicates the specific problem. Faults are classified as either a *critical fault* and specified by the Fault Indicator, or as an *ambient temperature fault* and specified in the ambient temperature field. TPS-Manager displays these continuously.

The *Fault Indicator* field is in each output record and holds *Fault event codes*, as a seven digit binary mask where every digit is either a zero (0) or a one (1). A zero indicates normal status, while a one indicates a problem. A string of seven zeros (0000000) indicates proper instrument operation. From left to right individual digits in the Fault Indicator field are defined as:

- Top plate fault:                   1 0 0 0 0 0 0
- Bottom plate fault:               0 1 0 0 0 0 0
- Current fault:                    0 0 1 0 0 0 0
- Voltage fault:                    0 0 0 1 0 0 0
- Resistance fault:                0 0 0 0 1 0 0
- Maximum value exceeded:       0 0 0 0 0 1 0
- Minimum value exceeded:       0 0 0 0 0 0 1

For example, a fault event of “1010001” indicates the electrical current flowing through the top plate was less than the defined minimum value. This indicates that quite likely either the top plate sensor cable is damaged or has become disconnected from the main PCB.

These *critical faults* disable the normal control algorithm that regulates the sensor heaters, and lowers the power supply duty cycle to only 1.5%. This low operating level still permits the analog-to-digital converter to perform auxiliary measurements enabling remote diagnosis. As soon as the fault condition is removed the system resumes normal operation.

**Note:** Usually, only a single fault event at a time is meaningful in the fault indicator code, *even if multiple faults exist*. For example, as the top plate is checked first, if you disconnect the sensor head, voltage and current are both zero. However, the first item detected will be the top plate, and that is the fault that will be indicated.

### Warm-up Indication

There is one important exception: when first powered on, the 10-minute warm-up period is indicated by a string of seven ones (1111111) in the status code. During the warm-up period, no precipitation will be measured or output, regardless of present conditions.

The *ambient temperature* field has a range of  $-50$  to  $+50^{\circ}\text{C}$ . An ambient temperature of  $-50^{\circ}\text{C}$  indicates that the ambient temperature sensor is disconnected. An ambient temperature of  $+50^{\circ}\text{C}$  indicates that the ambient



temperature sensor is short-circuited. Note that the ambient temperature measurement is essential to measure precipitation and thus no precipitation will be produced by the system interface during these temperature sensor malfunctions.

During a non-critical fault, generally the only valid data will be enclosure temperature. While *non-critical* faults such as ambient temperature do not halt normal thermal control of the heaters they do alter data output records to indicate that a fault has occurred. Non-critical faults are usually caused by a connector problem with the ambient temperature sensor and are indicated by out of range (-50°C) data.

Because precipitation rate calculations depend critically on accurate ambient temperature data, they are flagged in the output record as follows:

- Reported precipitation rate will always be zero
- Accumulated precipitation will remain unchanged from the last valid value
- Wind speed will always be zero
- Ambient temperature will be fixed at -50°C in the output record

Finally, the internal enclosure temperature sensor has a valid range of -50 to +100°C. An enclosure temperature of -50°C indicates that the enclosure temperature sensor is disconnected, and an enclosure temperature of 100°C indicates that the sensor is short-circuited. Note that if enclosure temperatures out of range conditions occur, they do not result in a fault condition. Therefore sensor control and output continues. Note this can occur briefly in winter in the arctic immediately after AC power is restored; also, the power supply itself has a thermal cutout that will fully shutdown the system if the interior overheats.

## Understanding LED States for Fault Detection

---

PCB Revision H  
(2011)

In addition to reporting fault conditions in the serial data stream, critical or non-critical issues are shown via dynamic blinking pattern via the status LEDs.

**Note:** The status LEDs allow you to see at a glance that a fault has been detected and are visible via a small window on the side of the electronics enclosure.

All systems have red and green LEDs located on the main PCB. Their operation is as follows:

- During initial warm-up period: *Solid Red* (with flashing green)
- Normal operation: *Flashing Green* (red off)
- Fault condition: *Flashing Red* (green off)

Revision F of the main PCB added the orange LED for +5Vdc; Revision G added the yellow LED for +12Vdc; Revision H added the blue LED for +48Vdc main DC supply. The blue LED allows determining that the heater fuse is blown while the controller is still working, because the PCB is fused separately from the main power supply.

# CHAPTER 4

## Maintenance

---

The instrument has been designed to provide long-term, trouble-free service in severe outdoor environments. However, as with all outdoor equipment a few basic maintenance procedures are required to verify the system is in good working order.

### In this chapter

Topic	Page
• Routine Maintenance	4-2
• Accessing Internal Components	4-4
• System Checkout Procedure	4-8
• Breaking Down and Packing the System for Shipment	4-17
• Product Warranty	4-21

To get an idea of maintenance procedures that you will perform on a regular schedule, see Routine Maintenance on page 4-1.

**Note:** After exposure to the weather, it is normal for the top and bottom surfaces of the sensor assembly to turn gray. If you are using the sensor continuously in the field for long term professional monitoring applications, we recommend that you perform annual calibrations. Contact YES support for more information

### Returning Items for Service

Whenever you ship the system for repair or recalibration, it is extremely important to follow the instructions on page Breaking Down and Packing the System for Shipment on page 4-17.

## Routine Maintenance

To obtain the best possible performance and accuracy, perform the following maintenance procedures on a regular scheduled basis:

### Seasonal Service

- **Seasonally: Check the surface of the plates for accumulated debris.** Note that it is normal for the top aluminum sensor plate to turn gray over time as it is exposed to precipitation. This does not affect the instrument and it is not necessary to clean this thin layer of oxidation. *Do not use an abrasive on the plates to attempt to clean them!*

### Yearly Service

- **Yearly: Clean the surface of the plates** —Clean the top plate using a mild solution such as Windex™ to wash deposited material off. Use a soft cotton cloth. Note that it is normal for the surface to turn gray with exposure. *Again, avoid using an abrasive on the plates to attempt to clean them!*
- **Yearly: Check the connecting cables** — Inspect the AC electrical and associated data cables for wind-wear, bird or animal damage, or general deterioration.

### Every 5 Years

- **Every 5 years: Replace the 3V lithium 2032 coin type battery** —located on the main PCB. This battery retains user settings and runs the clock during local AC power outages. They are available at hardware stores or Radio Shack.

### Factory Calibration

- **Periodic Calibration:** To ensure accurate data, YES suggests that you return the sensor for factory calibration, preferably yearly but at least every two years.

Over time, you will notice the sensor head will change color slightly with exposure to the weather. Usually, the sensor head surfaces are relatively self-cleaning. If a contaminant does fall on the sensor, the system will not overheat. The liquid component of the contaminate will evaporate rapidly from the metal plate surface, and once dried out, the organic solids left behind will tend to remain until put back into solution by future rainfall events. Meanwhile, the sensor will operate as usual.

During operation birds typically will not land on the sensor head because they have sensitive nerves in their feet and the plates are too uncomfortable for them to land on. However, if the system is left outside and powered off for long periods of time, it makes a good bird perch and bird guano can accumulate. Heat generally also prevents insects from landing on the head surfaces.

**Note:** To pack your system for shipment see Breaking Down and Packing the System for Shipment on page 4-17.

While natural deposits should not heavily affect sensor calibration, you can power down the system and clean the sensor with a mild detergent, followed by a thorough water flush. It's always good practice for a human observer to periodically check on the sensor avoid the temptation to use a scrubbing pad to clean the plates.

At the factory, systems are individually calibrated via the measurement of current, voltage and temperature of each sensor head as it undergoes exposure to a variety of conditions. These results are then verified in a well-controlled environment in a small wind tunnel. NCAR has compared a number of systems against many reference precipitation gauges at a well controlled field site to arrive at a final calibration of snowfall rate. Comparisons are on-going to verify that small changes in sensor design do not have unexpected consequences in calculated precipitation rates.

**Caution:** Always remove AC power to the system and let the sensor cool down prior to servicing or touching it! It is a good idea not to try to open and work on the electronics enclosure during inclement weather, especially when it is raining. Never work on the electronics with power applied, as there are lethal voltages inside. If it is raining or snowing and you must work on the system, relocate the system indoors or cover the entire area with a large tent to keep water from entering the electronics.

## Firmware Updates

Because the calibration is derived by the factory calibration, system firmware is updated as necessary during normal calibration.

# Accessing Internal Components

Other than the internal AC and DC power fuses, there are no user-serviceable parts in the electronics enclosure and we recommend that you return assemblies needing repair to YES for service. However, if you have the proper equipment and technical expertise, you can make certain repairs yourself:

- Replacing fuses
- Changing the AC line power
- Replacing the internal non-volatile memory lithium coin cell battery
- Replacing the sensor assembly

This section describes each procedure. As each involves opening the enclosure, this process is described first.

## Performing Disassembly:

Find an open location such as a work bench, and lay out the parts to be assembled. For tools, you will need a small flat set screwdriver, a medium sized Phillips screwdriver, an adjustable (crescent) wrench, a set of Allen wrenches and a large C-clamp.

## Opening the electronics enclosure

- 1 Identify the top of the electronics enclosure—the bottom has the AC and serial data cables exiting from it. Clamp the electronics enclosure's lower flange to a sturdy bench top using a metal C-clamp to hold it vertically.
- 2 Open the electronics enclosure door by loosening each door screw a little bit at a time. Note the enclosure door uses captive screws and each must be opened only a few turns each, similar to changing an automotive tire.
- 3 As you loosen each of the six captive door screws, gently pull the cover out. Once all the screws are free of their threads, gently slide the cover out from the enclosure until it reaches the metal door stops. Do not try to pull the door completely out of the enclosure, it is designed to stop as shown in Figure 20.
- 4 **IMPORTANT:** Observe how the head sensor cable harness is draped over the upper door stop bracket as seen below and in Figure 20. It is critical to ensure that the system is reassembled with this harness in the correct position, so that these cables are not pinched when you seal the door. Also, note the position of the door gasket for re-assembly later.

Note how sensor head cables are routed in front of metal stop here (avoid pinching!)

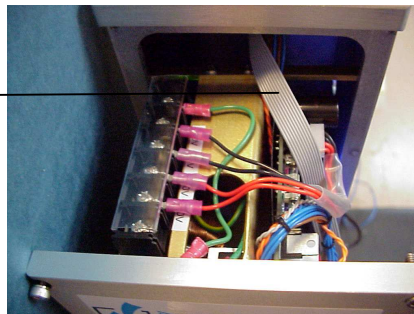

Figure 19. Note how head sensor cables are routed in front of stop bracket.

- 5 While the head sensor assembly is separable from the electronics enclosure, avoid letting it hang tethered by its harness under its own weight.
- 6 Using two hands and without pulling on the internal wiring to the sensor assembly, route the sensor wire bundle in front of the internal bracket as shown in Figure 21.

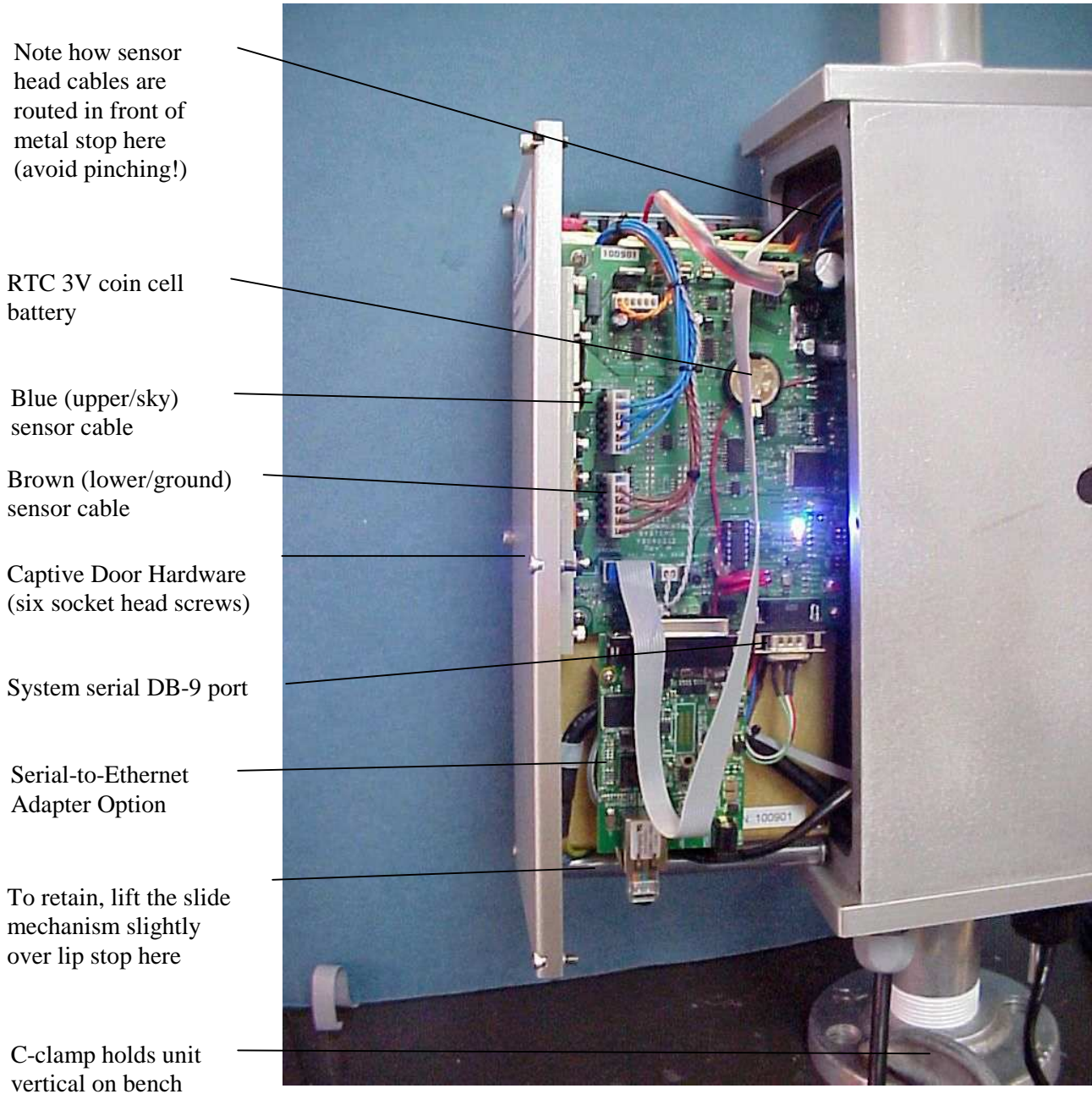

Figure 20. Electronics assembly shown with cover in open, extended position. (Revision H PCB with Serial-to-Ethernet adapter option at lower center.)

- 7 Using an Allen wrench, snug up the retaining setscrews on the sensor head such that it is loosely retained to the electronics enclosure. Do not fully tighten these screws yet—you may reorient the head later. Be careful not to twist the wires.



- 8** Locate and identify the labels on the chassis. The top plate sensor blue cable goes on the lower header if positioned vertically, (or if the system is positioned horizontally as shown above in Figure 24, to the right). The lower plate sensor brown cable runs to the upper header (or if positioned horizontally, as in Figure 24, to the left). Carefully connect the three polarized cables to their respective positions as shown in Figure 20.
- 9** Verify that each cable is in its proper position. Note that the two head sensor assembly cables are color-coded: blue *sky* is top and brown *earth* is bottom. (If these two cables are reversed, the system data will be invalid.)
- 10** Normally the system has been configured for your local line voltage at time of manufacture and you can simply plug the AC cord into an outlet and the serial RS-232 cable to your PC's serial port. Verify the line voltage switch, located at the end of the interior chassis. If you relocated the system to another country, you may need to change the switch position to match.
- 11** The external ambient temperature sensor probe may be shipped pushed in to protect it during transit. Gently pull the sensor out of its external strain relief and then hand tighten the outer clamp ring on the strain relief it with your fingers. Do not use a wrench on this plastic fitting.
- 12** Using care to ensure the head sensor harness is in front of the door stop bracket as shown in the lower section of Figure 21, gently re-close the enclosure door by tightening each screw a few turns at a time being careful not to cross-thread any screws. Work slowly. As you mate the door to the enclosure, visually inspect that the door gasket is properly seated in its machined groove.



Pull temp probe out and secure finger tight

Three set-screws secure sensor to top mast

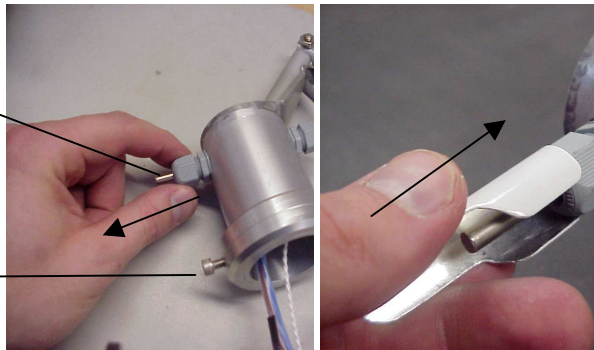

Ensure head cable is in front of aluminum bar

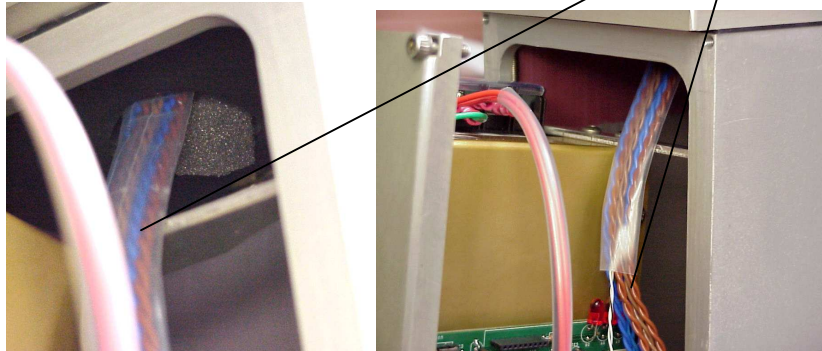

Figure 21. Extract the ambient temperature sensor probe and snug up its plastic strain relief, then slip on the white radiation shield. Note position of sensor cables, which must be routed in front of door retaining bracket in order to close door. Be careful not to pinch any cables when sealing the enclosure door!

**Caution:** It is imperative that the enclosure door does not leak in the field. Use extreme care to ensure the enclosure's O-ring cover seal is properly seated in its groove, such that the door is fully sealed when closed. Liquid leaks due to improper assembly will damage the system and void your warranty.

# System Checkout Procedure

This section describes some tests to try in the field if you suspect a problem. For these tests, you will need AC line power and a PC laptop with a straight wired (i.e. not a null modem) 9 pin, RS-232 serial cable. Sometimes, a direct or nearby lighting strike to either the AC line or the communications line will cause a system failure. Because the system is necessarily the tallest object around, this underscores the need for optical isolation on the communications link, as well as grounding and AC line surge protection.

**Caution:** You can perform these tests indoors or outside, however it is best to *avoid opening the side of the electrical enclosure while AC power is applied and it is raining or snowing*. If you must do this, always disconnect AC power first when opening the enclosure. Once the assembly is pulled out and you are sure no shorts to the grounded case can occur, you can apply AC power. If it is precipitating, cover the exposed electronics with plastic sheeting or an umbrella to protect it. Use gloves and shoes with rubber soles to protect you from the operating voltages inside.

## Opening the Electronics Enclosure

To open the electronics enclosure, refer to the procedure in the previous section.

## Understanding Status LEDs

With power applied, the warm up delay elapsed and the system up to operating temperature, you should see a green LED blinking on the main board indicating the CPU is operating. Blinking green indicates normal CPU operation while a blinking red indicates a critical fault has been detected and the system is shutdown to 1.5% duty cycle. The serial interface indicates the fault code status.

If you see no LEDs active, the serial port will not function. Usually this is due to AC power not being present or a blown internal fuse. Before you assume a blown fuse, test the outlet and verify the local Ground Fault Interrupter circuit breaker feeding the AC line has not tripped and cut power to the system. Once you've verified AC power is reaching the system with a DVM, and LEDs are active, use a terminal emulator test if commands are returned from the serial port. Try rebooting by power cycling the system. Disconnect and check the RS-232 cable for damage from animals or rodents. If lighting is suspected, change the MAX201 IC on the control PCB.

## Performing a Simple Drip Test

## Understanding Calculations in Low rate Conditions

Be sure the electronics enclosure is fully closed and sealed before proceeding. You can explore system response using a suitable serial terminal (e.g. Hyperterm™), and a method of delivering a metered amount of water to the top plate, either via a hypodermic needle, or a precision metering peristaltic pump. Use water at exactly the same temperature as the ambient air temperature, and use a syringe that creates a very fine sized water droplet.

Assuming a 1 Hz data acquisition rate, the orange points on Figure 22 show the calculated precipitation rate output, while the blue vertical lines show the start and stop of water delivery intervals to the top plate (each set of drops is spaced a few minutes apart and lasts a few minutes in duration). The horizontal line

shows the theoretical equivalent precipitation rate delivered by the syringe. Keep in mind that liquid delivery from the pump is quantified into small drops, each placed on the hot plate randomly. This figure shows typical observations (courtesy of Jeff Snider of the University of Wyoming) as comparison, and are broken down into “long” and “short” duration precipitation events.

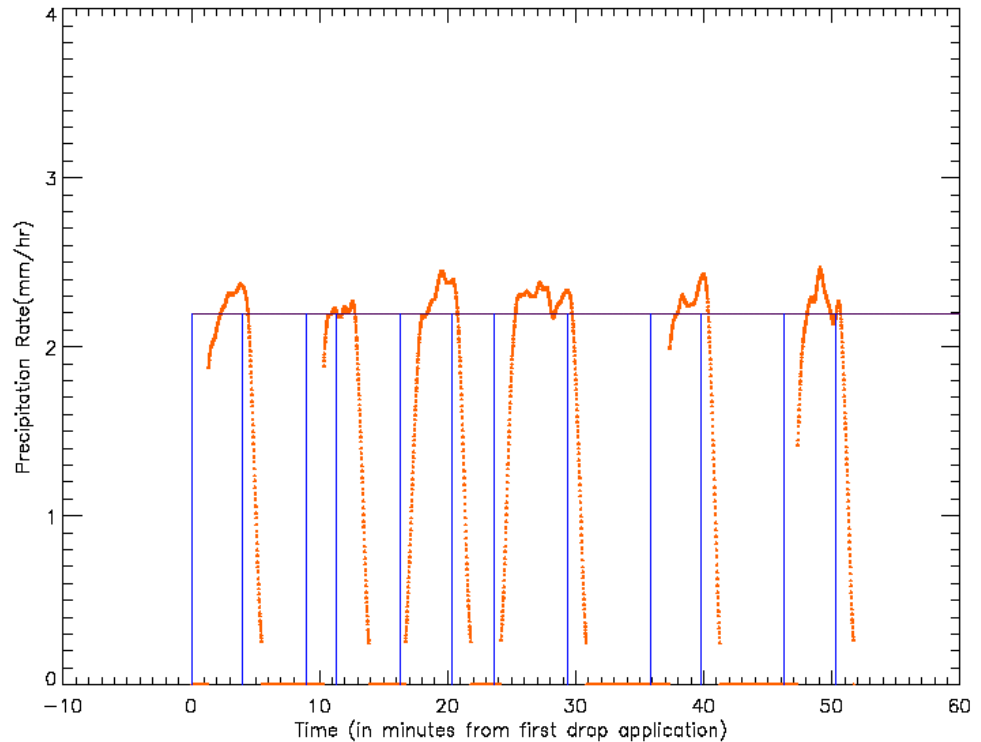

Figure 22. Typical drop test results. Note the effect of the internal data “box car” averaging has on the calculated output rate.

For longer duration precipitation events with greater than five minutes between the end of the last liquid water delivery event and the start of new liquid delivery, an approximately one minute delay occurs prior to reporting non-zero precipitation rates. This brief delay is caused by an internally calculated one minute moving average. Initial non-zero values reported can therefore slightly exceed the theoretically equivalent precipitation rate produced by the test pump.

For shorter duration precipitation events with less than five minutes between the end of previous liquid water delivery event, and the start of new liquid delivery, a slightly more ramped response is produced. The ramped response starts sooner than the longer duration response and this slight difference in response is caused by internal data smoothing.

In the sample figure above, longer duration scenarios are shown for the 1<sup>st</sup>, 2<sup>nd</sup>, 5<sup>th</sup> and 6<sup>th</sup> intervals, and the shorter scenarios are shown for the 3<sup>rd</sup> and 4<sup>th</sup> intervals.



At the initiation of storm events (very low precipitation rates) boundary conditions within the internal rate algorithm produces data that are slightly biased by internal numerical averaging.

**Note:** The internal rate algorithm that calculates precipitation rate employs both one minute and five minute *running averages*. The onset of precipitation is based on the five minute average of instantaneous precipitation. These averages are present to prevent random variations in wind speed on the top and bottom plates (induced by turbulence) from generating a false positive report of precipitation. Until the five minute averaged value exceeds 0.25 mm/hr, precipitation output is set to 0. After the threshold is exceeded, precipitation is deemed to have commenced.

Once precipitation has started, the output becomes the one-minute averaged value with a threshold of 0.25 mm/hr. Thus, the top graph shows zero precipitation until the five minute average (not shown in the graph) has built up to 0.25 mm/hr. Then the output jumps to the current 1-minute average. The gaps between input precipitation pulses are long enough to bring the five minute average back below the 0.25 mm/hr threshold, so the output looks the same for the second and third pulses.

In the middle graph, the initial jump is due to the delay in the five minute average determining that precipitation has started, as above. However, the pulses are close enough together that the 5-minute average stays above 0.25 mm/hr and the output simply follows the one minute average, except for the small jump from 0.25 mm/hr to 0. Finally, the reported wind speed and ambient temperature are both one minute averages of instantaneous values. Note that enclosure temperature is not averaged, since it is not used in the precipitation algorithm.



## Changing the AC Line Voltage or Replacing Fuses

Your system was configured at the factory for your local AC voltage. It is always a good idea to verify the voltage present at the feed with an AC DVM.

To change the AC line voltage between 100-125 and 220-250 Vac:

### AC Line Voltage

- 1 Disconnect AC power to the system.
- 2 The electronics enclosure cover uses captive hardware. Remove the cover by turning each screw just a few turns at a time and using a tire rotating pattern.
- 3 Note the position of the cover gaskets and the machined groove.
- 4 Carefully slide out the side cover with the internal electronics until it reaches the limit of the metal door stop. Note how the head cable harness is routed.

**Warning:** Placing the switch in the wrong position can permanently destroy the system and void your product warranty! Use care to verify it is in the correct position before applying power. Always ground the system post to a local ground rod for safety protection.

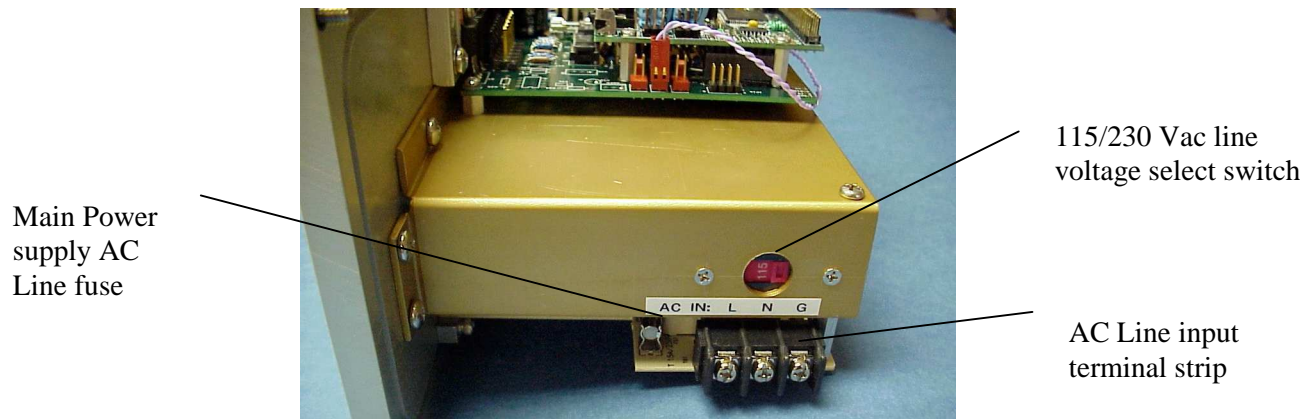

Figure 23. The line voltage switch, main AC fuse and input terminal strip. L=Line, N=Neutral and G=Ground.

- 5 Verify the position of the AC input line voltage switch, located at the AC power supply terminal strip inputs, is set to the proper voltage. See Figure 23 below for guidance, and measure the line with a DVM to be absolutely sure.
- 6 If you need to check fuses see the following section.
- 7 **IMPORTANT:** Verify that the sensor cable harness is properly routed around the metal door stop bracket exactly as it was when you disassembled it, such that on closing the enclosure it is not mechanically pinched by the bracket.
- 8 Slide the assembly back into the chassis until the screws engage, using care to not pinch any wires or the head sensor cable harness; again verify that the sensor head wire bundle passes in front of the metal fingers.



- 9 Avoid cross threading the screws and slowly seal the enclosure by turning each screw only a few turns at a time (similar to an automotive tire lug nut rotation). As you tighten each door screw, check that the gasket is properly seated. *It is essential that the door be completely sealed to prevent water infiltration, which will void your warranty.*
- 10 Check the level of the sensor using a bubble level in two directions and adjust as necessary.
- 11 Use the serial interface to set the clock and to reset the accumulated precipitation total.

**Warning:** The electronics enclosure must remain completely dry inside at all times. When servicing use extreme care to seat the gasket properly, sealing the door fully. Gaskets are critical to keeping it dry and heat keeps system internals dry. If you need to leave the system outside powered off for a prolonged period, either cover it up or bring it inside and **NEVER WORK ON IT LIVE WHILE IT IS RAINING.**

## Replacing Internal Fuses

---

Three internal fuses protect the system from line surges and major internal component failures; two fuses are on the main PCB and the third is near the power supply as shown in Figure 23. It is important to use the same type and rating fuse when replacing them.

If the main AC fuse blows, suspect that either the main AC-DC line supply has failed, the AC line voltage switch is set incorrectly or there was a power surge, or the fuse aged. This fuse is intentionally set somewhat light to protect the system. Over long periods of high current, metal migration will occur, which helps the fuse to fail even when its ratings have not been exceeded. As with standard best practice on aircraft you should replace the fuse every three years or so with the exact same type. If you do not change it over time it may age and blow when an AC line surge occurs.

A separate 10A “fast blow” type fuse is located on the main controller board, shown in Figure 24, is the DC input fuse between the AC-DC power supply and the main controller electronic regulators. Always replace this 3AG fuse with the same type. If the DC fuse blows, this may indicate a pinched wire internally, or a serious short circuit condition in the head. Contact technical support via methods described in *In this Manual* located just after the table of contents.

**Warning:** The internal control PCB is static sensitive, please use caution in handling it and be sure to ground yourself when moving it between the anti-static bag and the system. To avoid charges, always return the PCB module promptly to Yankee Environmental Systems for recycling. If you have any questions please contact Tech Support via methods described in the *In this manual* section.

**Always use the same fuse type and current rating**

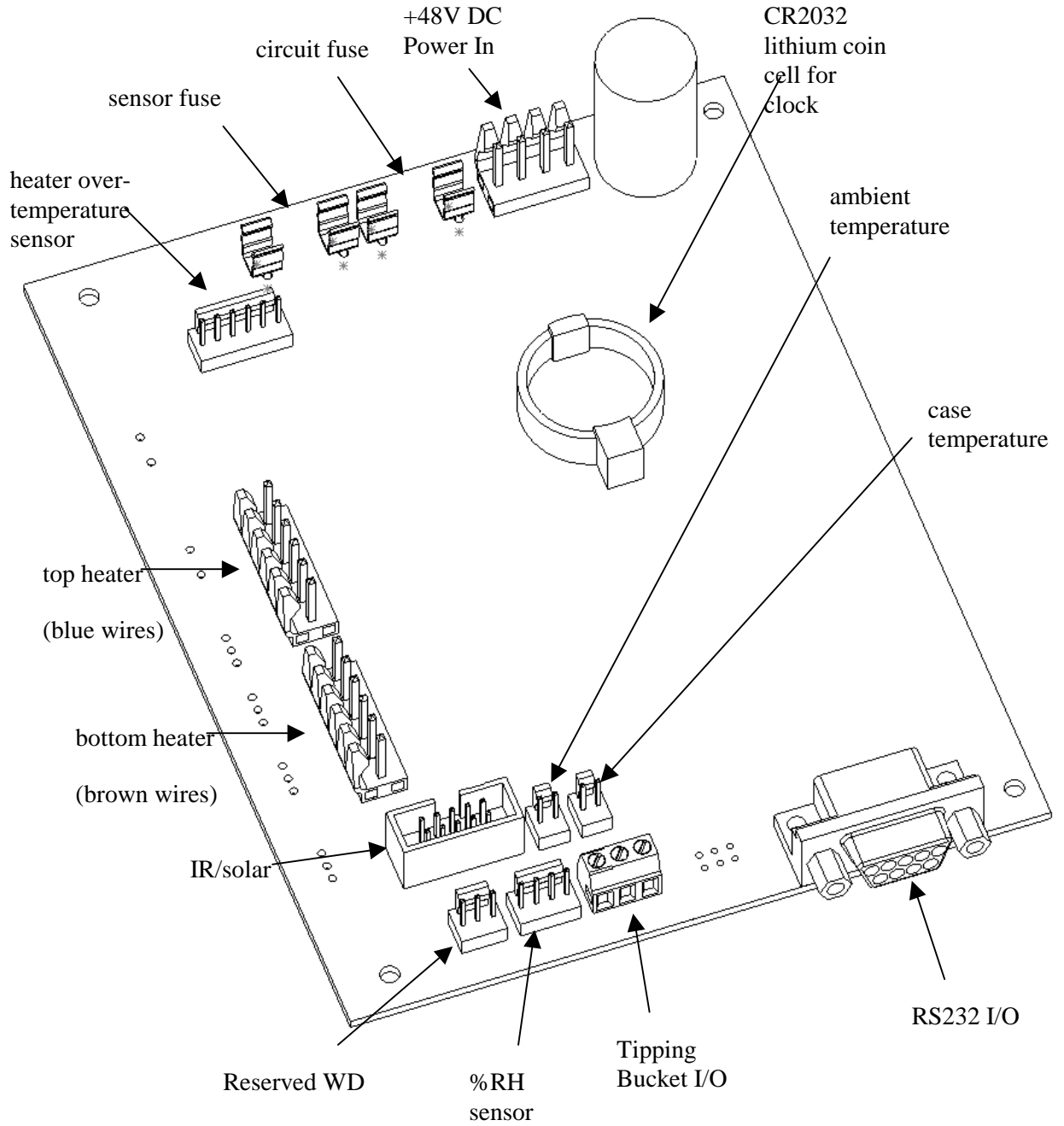

Figure 24. View of Revision H (2011) and later controller board.

## Replacing the RTC Lithium Battery

### Lithium coin cell battery

If the internal real time clock loses its settings whenever AC power is lost, this indicates you need to replace the standby lithium coin cell CR-2032 battery located on the main PCB inside the electronics enclosure. Several factors dominate how long the battery will last including how long the system was not powered and temperature extremes. After several years, the battery will run down, requiring replacement. Refer to Figure 24 on page 4-13:

- 1 Disconnect AC power to the system.
- 2 The electronics enclosure cover uses captive hardware. Remove the cover by turning each screw just a few turns at a time and using a tire rotating pattern.
- 3 Note the position of the cover gaskets and the machined groove.
- 4 Carefully slide out the side cover with the internal electronics until it reaches the limit of the metal door stop. Note how the head cable harness is routed.
- 5 Referring to Figure 20 and Figure 24 locate the coin cell battery from the main PCB, noting its polarity in the socket. Replace it with a new “CR-2032” lithium cell, available from [DigiKey](#), [Newark](#) Electronics, Mouser, Radio Shack and others. Insert the new battery using the same orientation.
- 6 **IMPORTANT:** Verify that the sensor cable harness is properly routed around the metal door stop bracket exactly as it was when you disassembled it, such that on closing the enclosure it is not mechanically pinched by the bracket.
- 7 Slide the assembly back into the chassis until the screws engage, using care to not pinch any wires or the head sensor cable harness; again verify that the sensor head wire bundle passes in front of the metal fingers.
- 8 Avoid cross threading the screws and slowly seal the enclosure by turning each screw only a few turns at a time (similar to an automotive tire lug nut rotation). As you tighten each door screw, check that the gasket is properly seated. *It is essential that the door be completely sealed to prevent water infiltration, which will void your warranty.*
- 9 Check the level of the sensor using a bubble level in two directions and adjust as necessary.
- 10 Use the serial interface to set the clock and to reset the accumulated precipitation total.

**Warning:** The electronics enclosure must remain completely dry inside at all times. When servicing use extreme care to seat the gasket properly, sealing the door fully. Gaskets are critical to keeping it dry and heat keeps system internals dry. If you need to leave the system outside powered off for a prolonged period, either cover it up or bring it inside and NEVER WORK ON IT LIVE WHILE IT IS RAINING.



## Replacing the Sensor Head

Refer to Figure 20 on page 4-5 and Figure 21 on page 4-7, to replace the Head sensor assembly:

### Note Original Orientation of Sensor Assembly

- 1 Disconnect AC power to the system.
- 2 Note the original orientation of the sensor head. To minimize turbulence created by the sensor arm, it should point into the direction of the most common prevailing winds at your site.
- 3 The controller enclosure cover uses captive hardware. Remove screws by turning each just a few turns at a time and using a tire-rotating pattern. Work slowly until the cover is free from the chassis.
- 4 Noting the position of the cover O-ring gaskets and the machined groove, carefully slide out the side controller electronics assembly until it stops.
- 5 Note the position of the two blue and brown sensor assembly cables as they connect to the controller board, and how they route through the chassis area, in particular how they pass around the metal door bracket stop.
- 6 Remove the two blue/brown connectors and the third ambient temperature thermistor cable from the PCB. Again, note how these cables thread over the metal door bracket before they exit into the upper support pipe.
- 7 Using your free hand, loosen the socket head screw clamp on the sensor mast and slip it up so that the cables slip up and out of the box. It is a good idea to have a helper hold the sensor; never let the sensor hang from its harness.
- 8 Slip in the new sensor and secure it into place, being careful to thread the cables in front of the metal stop bar.
- 9 Aim the arm in the original direction into the prevailing wind. For now, hand-tighten the three sensor head set screws to maintain the head in place.
- 10 Reconnect the sensor cables in their correct locations on the controller board, as well as the temperature sensor connector. Note that the upper blue (sky) cable is the upper plate while the lower brown (earth) is the lower plate. See Figure 20. Be sure to verify the position of each connector and that they are fully seated.
- 11 Orient the head in the same direction it was originally installed. (Note: if it was aimed at the earth's pole, see the installation section; we now recommend aiming the head in the direction of most common prevailing wind). Loosely snug up the three screws and check that the top plate is level.
- 12 **IMPORTANT:** Verify that the sensor cable harness is properly routed around the metal door stop bracket exactly as it was when you disassembled it, such that on closing the enclosure it is not mechanically pinched by the bracket.
- 13 Slide the controller assembly back into the chassis unit until the screws can engage, using care to not pinch any wires or the head sensor cable harness.

- 14 Avoid cross threading the screws and slowly seal the enclosure by turning each screw only a few turns at a time (similar to an automotive tire lug nut rotation). As you tighten each door screw, check that the gasket is properly seated. *It is essential that the door be completely sealed to prevent water infiltration, which will void your warranty.*
- 15 Using a bubble level in two directions verify the level of the top plate; adjust using the base flange bolts as necessary to keep the plates level.

**Warning:** The electronics enclosure must remain completely dry inside at all times. When servicing use extreme care to seat the gasket properly, sealing the door fully. Gaskets are critical to keeping it dry and heat keeps system internals dry. If you need to leave the system outside powered off for a prolonged period, either cover it up or bring it inside and **NEVER WORK ON THE SYSTEM LIVE WHILE IT IS RAINING!**



## Breaking Down and Packing the System for Shipment

If you are relocating the system to another location, or are returning the system to the factory, it is very important to pack the system carefully. Ideally, use the original packing materials when you ship the system, or the optional foam lined flight case. If you no longer have the original box, we recommend that you build a wooden crate to protect it. Mechanical disassembly generally follows the reverse of the steps section in Preliminary Assembly on page 2-2.



Figure 25. Optional flight case (top) and bubble wrapped unit (bottom). Be sure to wrap the individual parts in bubble wrap!

- 1 Disconnect all AC power and communication cables, label and waterproof them.



- 2 Unbolt the support flanges that separate the unit from the pole.
- 3 Set the unit on a flat surface or workbench.
- 4 The temperature sensor probe is somewhat fragile and needs to be protected during shipment. Using your fingers, remove the white radiation shield and loosen the plastic bushing that holds the probe in place. Then gently press the probe into the housing as far as it will travel to protect it.
- 5 Remove the hotplate sensor assembly from the electronics enclosure, following the reverse of the assembly instructions shown in Preliminary Assembly on page 2-2. During this process, use two hands and avoid putting strain or stress on the wiring that ties the head to the electronics enclosure.
- 6 Once the head and electronics are separated, close the electronics enclosure door and hand tighten the six screws following a tire rotation pattern.
- 7 Tape over the end of the pipes at the ends of the electronics enclosure so that Styrofoam packing peanuts do not become lodged inside the pipe.
- 8 Individually bubble wrap the hotplate sensor assembly and the electronics enclosure.
- 9 Next, hold the two wrapped parts together and wrap the sensor assembly and electronics unit together with several more layers of bubble wrap to make them a solid cohesive mass.
- 10 Place the bubble wrapped parts in the center of the box, tightly packing the rest of the voids in the box with either bubble wrap or Styrofoam packing peanuts. As contents will settle in shipping, *stuff the box very tightly* while taping it closed.

**Caution:** Often freight carriers stack other boxes on top of packages. The system may be damaged if it is simply shrink-wrapped on an open pallet. Always pack it in a secure box or crate and insure your shipment for full replacement cost.

**Do not ship without insurance!**

We strongly recommend that you insure your shipment using the carrier's own freight insurance, as freight carriers take much better care of items when they are insuring them directly. Always insure it for the full replacement value.

**Self-insured Customers**

Some entities such as the US government are *self-insured*. Government users should be wary of shipping on commercial carriers without paying for carrier insurance. Freight carriers will expect that items can take extremely abusive treatment, and are worth only the minimum default insurance coverage, often a few US dollars-per-pound. Essentially, carriers will avoid dropping boxes several meters onto concrete when they know they are responsible for any damages.

**Obtain and RMA Number first**

If you are returning the system for service or calibration, do not return systems to YES without first obtaining a valid *Return Merchandise Authorization* (RMA) number by following the RMA instructions listed at [www.yesinc.com](http://www.yesinc.com) under *support*. Shipments arriving without freight prepaid (e.g. C.O.D.) will be



refused, and those without a valid RMA number will experience a significant service delays and additional freight charges.

### International Shipments must be “Door-to-Door”

**Note:** If you are returning a system from an international location, you must ship freight prepaid “*door-to-door*” (not to a “US Airport” or “US port of entry”). Failure to ship items directly to the factory will result in significant additional freight charges that you will then be responsible for paying. Follow the RMA instructions carefully.

In summary:

- Before shipping, contact YES for a Return Merchandise Authorization (RMA) number by methods in the section *In this Manual* located just after the table of contents. A detailed RMA procedure is at [www.yesinc.com/support.html](http://www.yesinc.com/support.html)
- Wrap the components in bubble plastic and place it inside a wooden crate, a heavy cardboard box packed tightly with foam or the optional flight case.
- Insure the instrument for its full replacement cost and ship it freight and insurance prepaid in accordance with the RMA Instructions.

**Note:** YES does not accept either freight-collect or COD packages. For international shipments, always specify that the shipment be “door-to-door”, not to a “US port of entry”. At worst, failure to follow these instructions may result in loss of your package, or at best, significant delays and financial charges.

## Important Product Safety and Disclaimer Information

**Important:** READ THIS PAGE BEFORE USING THE SYSTEM!

### Be careful, it's hot!

Because the sensor head operates at an elevated temperature, there is always the potential for injury if you physically touch it or if it is improperly setup too close to the ground. Take the same precautions that you would while working near an electric stovetop. The sensor must be mounted such that it is out of reach of anyone standing under it, or install it inside a secure fence line such that children and unauthorized personnel are denied physical access to it *at all times*.

**Caution:** Fences create wind wakes. If you must fence it in, be sure it is far enough away so that it does not affect the wind pattern around the sensor. Installation factors are not within the control of the manufacturer and it is therefore your responsibility to install and use the system with appropriate caution.

### Lethal voltages present inside enclosure

There are potentially lethal voltages inside the system, therefore no work should be performed on it while it is connected to line power - always disconnect AC line power before servicing the system. Only operators familiar with the detailed operation of the system should be allowed to maintain it, and all servicing is to be performed by qualified, technically-trained personnel only.

**Danger:** Use extreme care when working on the system where the ground is wet, you can be killed! Always disconnect AC power first before opening the enclosure or touching the sensor head, and wear gloves and rubber soled shoes.

### Advisory use only

This equipment is not designed or intended for hazardous or otherwise life-critical applications. The complex and random physics of precipitation measurement depends on complex thermal behavior of the local atmosphere and is difficult to control. Yankee Environmental Systems, Inc. (YES) provides this equipment *as-is* and makes *no warranty as to the suitability of purpose of the product or the data it produces*. Data provided by the system are for “advisory” use only. While best practices have been employed in the design and manufacture of the system, malfunctions can and will occur, requiring periodic user-maintenance and intervention.

### Disclaimer

You agree to use the product and the data it provides *at your own risk*. YES, its agents, distributors, assigns, shareholders or employees are not responsible for any damages whatsoever, resulting from either proper or improper use of this product, or application of data it provides. Further, YES, its agents, distributors, assigns, shareholders or employees are not responsible for any injury or injuries that may result from improper installation, malfunction, system design elements, improper or normal operation, or as a result of real or perceived negligence on the part of anyone. By using the instrument, you agree to these terms herein included in this User Manual as provided with the system at time of purchase. If you have any questions about this policy or on using the equipment in your particular application, contact technical support before proceeding with installation via methods listed in *In This Manual* located just after the table of contents.

---

# Product Warranty

## Warranty Terms

The YES standard product warranty applies only to defects in manufactured parts as described by its general product warranty located at [www.yesinc.com](http://www.yesinc.com). Fuses are considered expendable and are not covered under the warranty.



---

## Documentation Feedback

While we strive to provide the highest level of technical accuracy in this document, we welcome any comments you have on this user guide, both positive and negative. Please do not hesitate to contact us via methods listed in the section *In this Manual* located just after the table of contents.

Also, be sure to check our corporate web site for the latest technical information—look in the *support* section, under the data sheets and in the *frequently asked questions* link. In addition to providing the latest development news, the YES web site [www.yesinc.com](http://www.yesinc.com) offers downloadable data viewer software updates to licensed customers, and in some cases tutorials on topics too changeable or complex to be covered in a printed manual (such as videos demonstrating complicated service procedures). You can also submit feedback and questions directly to the YES engineering team via the on line <http://support.yesinc.com> site.







**STOP!**

**READ**

**THIS**

**MANUAL**

**FIRST!**