

LEADING

Volume 7, Issue No. 1

NAVAL SURFACE WARFARE CENTER, DAHLGREN DIVISION

EDGE



E3

ELECTROMAGNETIC ENVIRONMENTAL EFFECTS

**Challenges & Solutions
for the 21st Century**



TABLE OF CONTENTS

Electromagnetic Environmental Effects

- 5** INTRODUCTION – ELECTROMAGNETIC ENVIRONMENTAL EFFECTS (E3) AND THE NAVSEA WARFARE CENTERS
Rear Admiral James J. Shannon

- 6** INTRODUCTION – MEETING THE ELECTROMAGNETIC ENVIRONMENTAL EFFECTS CHALLENGE
Captain S. A. Patterson

- 7** INTRODUCTION – ELECTROMAGNETIC ENVIRONMENTAL EFFECTS (E3): ENGINEERING THE NAVY'S MISSION SUCCESS
Mrs. Virginia S. Hudson

E3 CHALLENGES FACING THE U.S. NAVY

- 8** NAVSEA HEADQUARTERS' PERSPECTIVE – ENABLING FUTURE NAVAL CAPABILITIES
David M. Johnson

- 18** THE IMPORTANCE OF E3 SCIENCE AND TECHNOLOGY IN PREPARATION FOR FUTURE WARFARE
Lucas Hale and June Drake

A BRIEF HISTORY

- 24** A SHORT HISTORY OF NSWC DAHLGREN'S INVOLVEMENT IN THE SHIPBOARD ELECTROMAGNETIC COMPATIBILITY IMPROVEMENT PROGRAM
George Winters

SOLVING THE E3 CHALLENGE

- 30** SPECTRUM MONITORING FOR THE FLEET
Jonathan Vick, Jeff Acree, and Bruce Naley

- 36** NSWC DAHLGREN'S ROLE IN THE NAVY'S SPECTRUM CERTIFICATION PROCESS
John Darden

- 42** SHIPBOARD ELECTROMAGNETIC INTERFERENCE PROBLEM SOLVING
Bradley Conner and Richard Soares

- 48** THE AN/SPS-67 WAVEGUIDE FILTER
Rick Gustavus

- 52** NEW BROADBAND SATELLITE TERMINALS INSTALLED ON SMALLER SHIPS
Wayne Gaston

- 56** USE OF RADAR-ABSORBING MATERIAL TO RESOLVE U.S. NAVY ELECTROMAGNETIC INTERFERENCE PROBLEMS
Bill Marker

- 62** COMPLEX CAVITIES: ASSESSING THE ELECTROMAGNETIC ENVIRONMENT OF BELOW-DECK SPACES IN NAVY SHIPS
Gregory B. Tait and Michael B. Slocum

- 68** THE DEPARTMENT OF THE NAVY'S HERO PROGRAM
Charles C. Denham

- 78** JOINT AND COALITION FORCES IN THE OPERATIONAL ELECTROMAGNETIC ENVIRONMENT
Charles C. Denham



E3

TABLE OF CONTENTS
(Continued)

SOLVING THE E3 CHALLENGE (Continued)

86 LOW-FREQUENCY MAGNETIC FIELD LIMITS FOR THE NAVY'S HERO PROGRAM
Charles C. Denham

90 COMPUTATIONAL ELECTROMAGNETICS FOR INTEGRATED TOPSIDE DESIGN
Gregory A. Balchin

100 USN INTEGRATED TOPSIDE DESIGN
Mark Silva

BEYOND THE U.S. NAVY

104 SUPPORT TO HURRICANE KATRINA DISASTER RELIEF OPERATIONS
Margaret Neel

108 E3 SUPPORT OF COUNTER REMOTE-IED ELECTRONIC WARFARE
Kenneth D. Larsen, D. Michael Mearns, and Albert H. Pitts

114 INTEGRATED TOPSIDE DESIGN SUPPORT FOR THE U.S. COAST GUARD NATIONAL SECURITY CUTTER
Richard E. Thompson

GETTING THE WORD OUT

118 THE STAN DATABASE
Bob Zanella

124 EMI STRIKE GROUP CAPABILITIES AND LIMITATIONS
John Gammon, II and Alexi Schandl

128 WHEN THE NAVY IS NOT FIGHTING, IT IS TRAINING.
WHEN THE NAVY IS FIGHTING, IT IS TRAINING.
Wayne Lutzen



LEADING

Volume 7, Issue No. 1

EDGE



NAVAL SEA SYSTEMS COMMAND

Vice Admiral Kevin M. McCoy, *Commander*
Brian J. Persons, *Executive Director*

NAVSEA WARFARE CENTERS

Rear Admiral James J. Shannon, *Commander, NSWC*
Rear Admiral David C. Johnson, *Commander, NUWC*
Mr. Donald F. McCormack, *Technical Director, NUWC*
Mr. Stephen E. Mitchell, *Technical Director, NSWC*
Mr. David M. Johnson, *SEA 05W*

NAVAL SURFACE WARFARE CENTER, DAHLGREN DIVISION

Captain S. A. Patterson, *Commander*
Stuart A. Koch, *Technical Director (Acting)*
Russell Coons, *Corporate Communications Director*
Margie Stevens, *Coordinator*
Patrice Waits, *Editor & Layout*
Clement Bryant, *Layout Design & Graphic Artist*
Brandy Anderson, *Cover Design*
Trey Hamlet, *Graphic Artist/3-D Modeling*

ELECTROMAGNETIC ENVIRONMENTAL EFFECTS

Virginia S. Hudson, *Q Department Head*
Steve Zehring, *Senior Project Engineer*
Ken Larsen, *Head, E3 Force Level Interoperability Branch*

NSWC DAHLGREN

Jeff Acree	Bruce Naley
Gregory A. Balchin	Margaret Neel
Bradley Conner	Albert H. Pitts
John Darden	Mark Silva
Charles C. Denham	Michael B. Slocum
June Drake	Richard Soares
John Gammon, II	Gregory B. Tait
Wayne Gaston	Richard E. Thompson
Rick Gustavus	Jonathan Vick
Lucas Hale	George Winters
Bill Marker	Bob Zanella
D. Michael Mearns	

NSWC PORT HUENEME

Alexi Schandl

SPAWARSYSCEN ATLANTIC

Wayne Lutzen

The Leading Edge Magazine is an official, authorized publication of the Naval Warfare Center Enterprise. The purpose of the publication is to showcase technical excellence across the Warfare Center Enterprise, and promote a broader awareness of the breadth and depth of knowledge and support available to the Navy and DoD at NSWC/NUWC.

Address all correspondence to C6 Public Affairs Office
Email: dlgr_nswc_c6@navy.mil; or write to
Commander, Naval Surface Warfare Center
C6 Public Affairs Office
18179 Dahlgren Road
Dahlgren, VA 22448-5100

NSWCDD/MP-09/31

Approved for public release; distribution is unlimited.

E³



E3 – Electromagnetic Environmental Effects

Introduction

ELECTROMAGNETIC ENVIRONMENTAL EFFECTS (E3) AND THE NAVSEA WARFARE CENTERS



Rear Admiral James J. Shannon
Commander, NSWC

Communications, electronics, and sensor systems aboard U.S. naval ships and submarines must operate effectively in order to support the execution of military missions and operations. Whether operating alone or with coalition forces, the Navy must be prepared to execute its missions anywhere in the world and under any condition. We must also be prepared to operate effectively throughout the entire frequency spectrum. As such, the Navy's systems must operate and interoperate safely and effectively without interfering with or degrading the system performance of other systems aboard ship. It is also necessary that U.S. systems do not impact, or be impacted by, other coalition or adversary systems operating in the same electromagnetic environment.

This issue of *The Leading Edge*, sponsored by the NAVSEA Warfare Centers, is dedicated to the critically important area of electromagnetic environmental effects, otherwise referred to as E3. It is an area that touches all naval operations—afloat and ashore, and all spectrums of conflict. So, whether the Navy's actions involve combating traditional adversaries, countering terrorism, thwarting pirates, responding to natural disasters, or supporting humanitarian operations, the Navy's systems must operate effectively and reliably in the electromagnetic environment in order for its missions to succeed. Ensuring that the Navy's missions succeed underlies one of the NAVSEA Warfare Centers' most important roles.

The Naval Surface and Undersea Warfare Centers research, develop, test, and evaluate cutting-edge technologies to arm the Navy with the capabilities it needs to fight and win in the electromagnetically challenged environment. They make certain that the Navy's individual components are designed, developed, and integrated as systems so that they perform optimally and interact seamlessly with other systems to achieve operational readiness. As an experienced commander and operator at sea, I understand the critical need for electronic, communications, and sensor systems to operate safely and effectively. I also understand how important it is for a ship commander and crew to have confidence in the ship's systems. If they do not function properly, missions can be seriously degraded, and lives can be lost.

With these thoughts in mind, I am pleased to introduce this issue of *The Leading Edge*. I invite you to explore its pages and learn about the exciting and important work being accomplished by Warfare Center scientists, engineers, technicians, and professional support personnel. As a result of their dedication, hard work, and contributions, I am proud to say that our warfighters, our Navy, and our nation are stronger, safer, and more capable than ever before.

A large, stylized, blue 3D-effect logo of the letters 'E3' is positioned in the lower-left quadrant of the page. The background of the page features a faint image of a naval ship at sea with digital data lines overlaid.

Introduction

MEETING THE ELECTROMAGNETIC ENVIRONMENTAL EFFECTS CHALLENGE



Captain S. A. Patterson, USN
Commander, NSWCDD

With the ever-increasing number of complex systems and systems of systems aboard ship, electromagnetic interference is a continuous challenge. I am encouraged that we are meeting this challenge by providing technological solutions to ensure a safe environment, both afloat and ashore. Through the genius of our scientists and engineers—who constitute our collective electromagnetic environmental effects (E3) expertise—we are keeping our sailors safe and achieving operational readiness.

By taking a look at where we've been, beginning with the earliest hazards of electromagnetic radiation to ordnance (HERO) research and development, it is evident that our grounding in electromagnetic technologies is the bedrock of our continuing solutions for the hazards posed by magnetic fields. The importance of our history is further confirmed in the evolving methodology and examples of applications of our engineering analysis that are presented in this E3 issue of *The Leading Edge*.

It is enlightening to read about the history of E3 research and the continuing investigation into E3 technology here at NSWC Dahlgren. Tackling E3 challenges, however, has not been our job alone, but has been, and continues to be, a joint effort across the warfare centers. As David Johnson, NAVSEA 05W43, points out in discussing the Tri-SYSCOM EM Leadership team, our E3 solutions are the product of careful coordination and broad collaboration of scientists and engineers across NAVSEA.

Besides featuring the many ship and submarine applications, some of the articles in this issue of *The Leading Edge* demonstrate how we employ E3 technology beyond the U.S. Navy. Wider applications include support of our warfighters through innovations in counter remote control improvised explosive device electronic warfare and defending our nation here at home through integrated topside design support for the U.S. Coast Guard. In addition, our Afloat Electromagnetic Spectrum Operations Program (AESOP) engineering team's analysis of electromagnetic interference tells the story of how we applied E3 knowledge to support Hurricane Katrina Disaster Relief Operations. Other articles show how we ensure that the latest EM technologies are infused into our knowledge-sharing initiatives and training.

I am proud to be Commander of one of the Navy's premier research and development facilities for E3 technology and am confident that NSWCDD will continue its legacy as a leader in providing E3 solutions for the Next Navy and the Navy After Next.

A large, stylized, blue 3D logo of the letters "E3" is positioned in the lower-left corner of the page. The background of the entire page is a blue-tinted image of a submarine's conning tower and mast structure on the water's surface, with a grid pattern overlaid.

Introduction

ELECTROMAGNETIC ENVIRONMENTAL EFFECTS (E3): ENGINEERING THE NAVY'S MISSION SUCCESS



Mrs. Virginia S. Hudson
Head, Electromagnetic and Sensor Systems
Department

Welcome to our E3 issue of *The Leading Edge*. If you are new to the world of electromagnetic environmental effects, prepare to be surprised by the spectrum of products and services that we provide to our Navy and nation.

Electromagnetic environmental effects, or E3, as it is also known, represents the impact of the electromagnetic environment upon the operational capability of military forces, equipment, systems, and platforms. It encompasses all electromagnetic disciplines, including electromagnetic compatibility and interference; electromagnetic vulnerability; electromagnetic pulse; electronic protection; hazards of electromagnetic radiation to personnel, ordnance, and volatile materials; and natural phenomena effects, such as lightning and precipitation static. Understanding and controlling E3 is essential for the protection of people, ordnance, and missions when operating electronic systems (e.g., communications, radars, weapons, sensors, etc.) in the electromagnetic environment.

The Electromagnetic and Sensor Systems Department, located at NSWC Dahlgren, Virginia, supports the U.S. surface Navy's current and future E3 needs. Our mission is to deliver unsurpassed electromagnetic technologies, systems, and solutions to our naval forces and nation. We take great pride in performing our mission, while also recognizing that much more needs to be done.

A number of organizations—some of which have offered articles for this publication—and people representing our partners from across government, academia, and industry contribute toward making sure that our Navy maintains spectrum advantage over its adversaries. Our Electromagnetic and Sensor Systems Department, for example, is frequently called upon for its expertise in solving some of the Navy's most complex electromagnetic and sensor system challenges. A continuing concern we face, however, is that sometimes we might not be called upon for our expertise until after systems have already been designed, developed, and integrated on naval platforms. As such, situations sometimes surface when radar or sensor systems interfere with communications systems, or vice versa, or when extremely hazardous situations result from electromagnetic radiation impacting fuel, ordnance, or people. Consequently, not only are our sailors and our Navy's missions at risk, but by operating this way, achieving naval readiness takes longer and costs more.

Many of today's electromagnetic problems could be prevented by applying our E3 expertise at the front end of the acquisition systems design, development, and integration cycle rather than at the end. By doing so, electromagnetically dependent naval systems would be designed and systems engineered and integrated—as *systems*—designed to work optimally together to achieve peak performance while concurrently ensuring naval readiness and the safety of naval personnel. Thus, it's not just about understanding or fixing things in the electromagnetic environment; it's about designing a better future for the Navy.

Clearly, a great many E3 challenges require solutions in the 21st century—a statement that also serves as the theme for this issue of *The Leading Edge*. It further serves as our enduring quest as we work to arm our Navy and our nation with the capabilities necessary to help ensure that missions succeed, that adversaries are defeated, and that our homeland remains protected. I invite you to explore the broad and varied spectrum of articles in this issue to learn about our products and services, and the tremendous value that the E3 community provides.



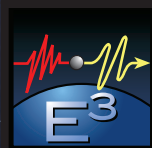

NAVSEA HEADQUARTERS' PERSPECTIVE — ENABLING FUTURE NAVAL CAPABILITIES

By David M. Johnson, NAVSEA 05W43

The military faces increasingly complex and challenging problems in developing and fielding platforms, systems, subsystems, and equipment. Evolutionary acquisitions, including spiral and incremental developments, are the preferred approach to satisfying operational needs. However, an appropriate balance is required among key factors, such as operational needs, interoperability, supportability, and affordability of alternative acquisition solutions.

The electromagnetic environment (EME) in which naval systems must operate is created by a multitude of sources. Primary contributors are:

- Own-ship; own-force, and other friendly transmissions
- Enemy transmissions
- Spurious emissions from equipment
- The ship's metallic hull
- Natural and environmental noise
- Possibly electromagnetic pulse (EMP) resulting from a nuclear burst

The dominant contributor(s) to the EME will depend on the platform's (or system's) locale and operating circumstances. Many elements of the EME are vital to system performance; others are potential sources of electromagnetic interference (EMI). Moreover, electromagnetic signals vital to one system's performance may prove fatal to another system's performance. Increased awareness of the EME enhances identifying and reducing platform/system EMI.

Department of Defense (DoD) policy requires that all electrical and electronic systems, subsystems, and equipment, including ordnance containing electrically initiated devices, to be mutually compatible in their intended EME without causing or suffering unacceptable mission degradation due to electromagnetic environmental effects (E3). Accordingly, appropriate E3 requirements must be imposed to ensure a desired level of compatibility with other collocated equipment (intrasystem) within the applicable external EME (intersystem, radio frequency (RF), lightning, EMP, and precipitation static) to address the safety of personnel, ordnance, and fuel in these environments. In addition, national, international, and DoD policies and procedures for managing and using the EM spectrum direct program managers (PMs) who are developing spectrum-dependent systems or equipment to consider spectrum supportability requirements and E3 control early in the development process and throughout the acquisition life cycle.





NAVAL SEA SYSTEMS COMMAND (NAVSEA)

NAVSEA comprises command staff, headquarters directorates, affiliated program executive offices (PEOs), and numerous field activities. NAVSEA is accountable to the Chief of Naval Operations (CNO) to deliver, modernize, and maintain a 313-ship Navy that meets the requirements of our national security plans. NAVSEA engineers, builds, buys, and maintains ships, submarines, and combat systems that meet the fleet's current and future operational requirements. NAVSEA is the largest of the Navy's five system commands. With a fiscal year 2008 budget of \$24.8 billion, NAVSEA accounts for nearly one quarter of the Navy's entire budget. It includes a force of 53,000 civilian, military, and contract support personnel.

NAVSEA manages acquisition programs (150) and foreign military sales cases that include billions of dollars in annual military sales to partner nations. NAVSEA strives to be an efficient provider of defense resources for the nation and plays an important role in the Navy Enterprise. As a Provider Command, it has the responsibility of directing resources from resource sponsors into the proper mix of manpower and resources to properly equip the fleet. NAVSEA has the further responsibility of establishing and enforcing technical authority in combat system design and operation. These technical standards use the organization's technical expertise to ensure that systems are engineered effectively, and that they operate safely and reliably.

TECHNICAL AUTHORITY WARRANT

NAVSEA's Force E3/SM Engineering Branch (05W43) has been assigned as the Technical Authority Warrant for EMI Control/Electromagnetic Compatibility (EMC)/EMP/and Radiation Hazards (RADHAZ) for Ships and Submarines. As a Technical Warrant Holder (TWH), NAVSEA 05W43 controls EMI/Spectrum and EMP impacts on warfare systems effectiveness to maintain warfighting readiness for all ships, submarines, and systems.

Virtual Systems Command (SYSCOM) Engineering and Technical Authority Policy, VS-JI-22A, defines the engineering and technical authority policy and actions needed to support PMs and the fleet in providing best-value engineering and technical products. The TWH must demonstrate sufficient proven ability in the following competencies in order to hold the warrant:

- Setting Technical Standards—Establish technical policy, standards, tools, requirements, and processes, including certification requirements.
- Technical Area Expertise—Provide technical advice to the fleet, depot chief engineers, and other DoD customers. Maintain technical expertise, and interface with the science and technology (S&T) community in technical areas related to EMI Control/EMC/EMP/RADHAZ for ships and submarines.
- Ensuring Safe and Reliable Operations—Ensure that safety and reliability is properly addressed in technical documentation. Ensure

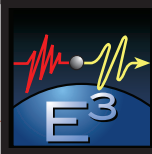

that products are in conformance with technical policy, standards and requirements. Where they are not, identify options and risks; minimize risks so they are technically acceptable.

- **Ensuring Effective and Efficient Systems Engineering**—Ensure that engineering and technical products meet Navy needs and requirements, including interoperability. Support programmatic authorities and the fleet by providing best-value engineering and technical products.
- **Judgment in Making Unbiased Technical Decisions**—Provide leadership and accountability for all engineering and technical decision-making. Promote and facilitate communications to ensure that appropriate personnel and organizations are aware of, and are involved in, technical issues and technical decisions.
- **Stewardship of Engineering and Technical Capabilities**—Ensure that an appropriate

engineering and technical authority support network is established for the warranted technical area and provide leadership for the support network.

- **Accountability and Technical Integrity**—Exercise integrity and discipline to ensure the soundness of technical decisions. Keep organizational chain of command informed of issues and decisions.

To move forward and execute the required TWH competencies, NAVSEA 05W43's goal is to partner with each system, ship, or submarine program to provide the best products to the warfighter. This is accomplished by getting "plugged-in" at the earliest stages of program development. NAVSEA subject-matter experts (SMEs) help guide individual programs through the E3/spectrum certification (SC) process, through requirements identification and controls implementation, and in exercising the Technical Warrant Pyramid (see Figure 1). In this manner, NAVSEA 05W43 works with the PEOs to implement upfront E3/

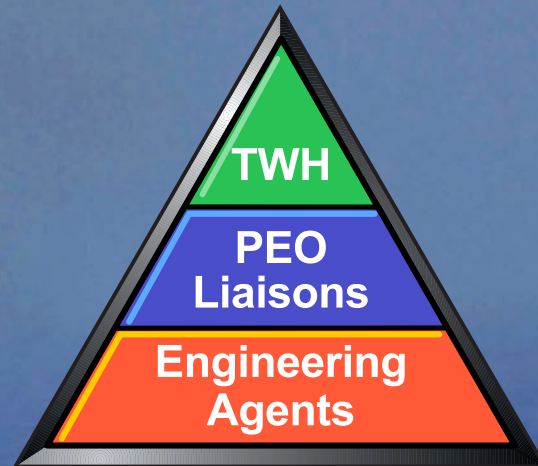

Figure 1. Technical Warrant Pyramid



SM engineering. These processes and procedures are executed by the Force Level EMC Program. The Shipboard Electromagnetic Compatibility Improvement Program (SEMCIP) is a subelement of this overarching program.

SHIPBOARD ELECTROMAGNETIC COMPATIBILITY PROGRAM (SEMCIP)

SEMCIP was established by NAVSEA under the sponsorship of CNO N6. SEMCIP provides “cradle-to-grave” systems engineering for mission assurance and EMC/spectrum management (SM) engineering to ensure that equipment, systems, ships, and submarines meet mission requirements/goals in their intended operational environment. The Force-Level EMC Team:

- Provides a central engineering capability to prevent, identify, and correct EMI problems
- Ensures that EMC is adequately addressed during all phases of the design and overhaul/modernization of ships, submarines, and ship systems
- Provides EMI control policy, processes, and documentation (i.e., instructions, tools, processes, and standards)
- Provides technical support to PMs to obtain frequency allocation/certification for shipboard equipment/systems
- Provides EMI fixes to correct mission-degrading EMI problems on deploying ships and submarines, thereby restoring combat capability and fleet readiness.

The successful execution of these E3 and SM initiatives require effective working relationships with appropriate outside agencies and entities that affect Navy EMC and spectrum supportability.

TRI-SYSCOM EM LEADERSHIP

NAVSEA Headquarters leads the Tri-SYSCOM organization among the Space and Naval Warfare Systems Command (SPAWAR), NAVSEA, and the Naval Air Systems Command (NAVAIR) for EMI control, EMP, and SC matters. Figure 2 shows the



top-down organization of the Force-Level EMC Program. NAVSEA has up-front systems engineers within its headquarters organization to interface with the various PEOs; e.g., PEO-Ships, PEO-Carriers. At the field activity level, NAVSEA designates engineering agents (EAs) for specific functional areas. These EAs form teams of SMEs to assist in the investigation and resolution of EMI problems ashore and afloat. These activities champion and

execute E3/SM in the design, development, procurement, and integration of equipment and platforms, as well as naval shore sites. NAVAIR and the Naval Research Laboratory (NRL) have been designated as support activities to NAVSEA.

The field activity technical teams (as illustrated in Figure 2) are:

- Naval Surface Warfare Center, Dahlgren Division (NSWCDD) Code Q50: Serving as the EA for Surface Ships. NSWCDD Q50 is assigned as the life-cycle engineering manager (LCEM), in-service engineering agent (ISEA), and design agent



(DA) to the ships as a whole entity, encompassing the ship itself and all systems, subsystems, and equipment. They manage efforts in the following areas:

- ♦ E3 EA for Surface Ships
 - ♦ EMI Reduction
 - ♦ EMI Control
 - ♦ Platform Certification
 - ♦ Fleet Response Plan (FRP)
 - ♦ Strike Force SM
 - ♦ Specification/Standards & Policies/Process
 - ♦ Warrant Holders
- Naval Undersea Warfare Center (NUWC) Code 3431: Serving as the EA for Submarines. NUWC Code 431 is assigned as LCEM, ISEA, DA, and Technical Support Activity (TSA) to the submarines as a whole entity, encompassing the submarine itself and all systems, subsystems, and equipment. They perform engineering and problem in-



vestigation to resolve high-priority fleet EMI problems, support submarine predeployment EMI surveys, and provide quick-response capability (QRC) to deployed submarines and support systems.

- Naval Surface Warfare Center, Carderock Division (NSWCDD), Code 953: Serving as the EA for E3 Engineering and SME for Hull, Mechanical, and Electrical (HM&E) Systems. NSWCDD Code 953 is assigned as LCEM and ISEA for EMI, EMC, and SM of HM&E. They provide engineering, analytical, and technical support to achieve EMC among and between HM&E systems and/or



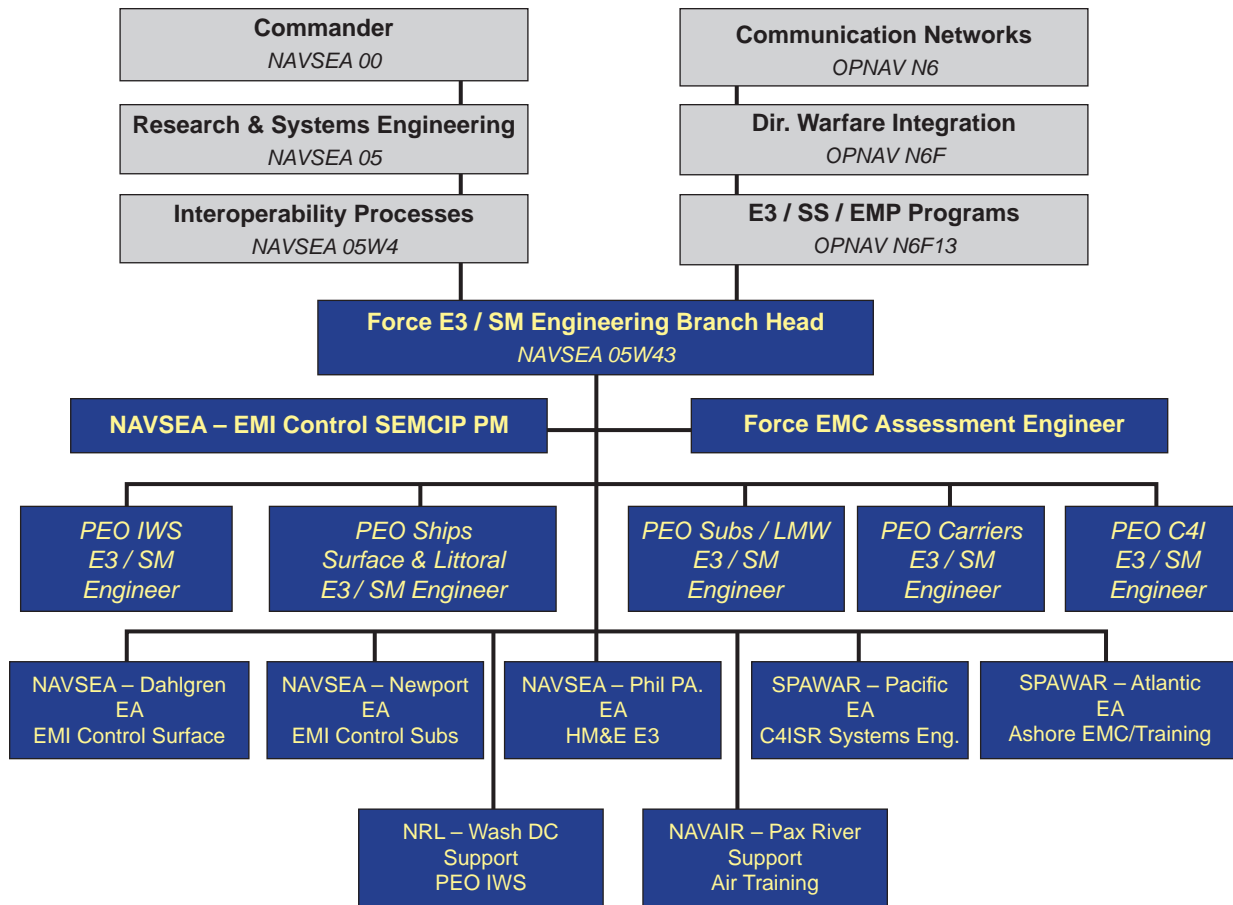
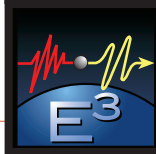

Figure 2. NAVSEA 05W43 Organization

equipment and assist in testing and resolution of shipboard HM&E EMI problems.

- SPAWAR System Center (SSC), Pacific: Serving as the EA for command, control, communications, computers, and intelligence (C4I) systems. SSC Pacific provides life-cycle upfront engineering support for operational Navy ships, with emphasis on system acquisition to eliminate significant degradation from EMI to the warfighting capability of



the fleet. They provide assistance to various PEO C4I & Space/SPAWAR/SSC program offices with E3 and SM issues affecting command, control, communications, computers, intelligence, surveillance, and reconnaissance (C4ISR) development and installation efforts. Additionally, they provide participation in national standardization groups,

such as American National Standards Institute (ANSI) C63 and North Atlantic Treaty Organization (NATO) working groups on naval E3 standardization issues affecting international coalition efforts.

- SPAWAR System Center (SSC), Atlantic Code 725: Serving as LCEM and TSA for EMC and SM training. SSC Atlantic Code 725 is also the EA for Navy shore site E3/SM. They provide engineering, analytical, and technical support to achieve EMC among and between ashore electronic/electric systems and/or equipment. They provide establishment of E3/SM training requirements for fleet management, engineering, operations, and maintenance personnel associated with cognizant systems, platforms, and facilities.





They provide E3/SM related engineering evaluations and support for Navy shore facilities.

- Naval Research Laboratory (NRL), Washington, DC: Serving as a support activity to NAVSEA for research and development related to E3 engineering and SM ships and systems.
- Naval Air Systems Command (NAVAIR), Patuxent River, Maryland: Serving as a support activity to NAVSEA through development and presentation of air-specific multimedia E3 and SM training. NAVAIR provides development, presentation, training specialists, fleet trainers, and E3/SM SMEs to review, revise, update, develop, and present multimedia operator, maintenance, officer,



and Department of the Navy (DON) civilian air-specific E3/SM curricula. They also administrate their SEMCIP counterpart program for Air systems called the “Air Systems Electromagnetic Interference Corrective Action Program (ASEMICAP).”

UPFRONT ENGINEERING

The Technical Warrant Pyramid describes the depth of knowledge and expertise that exists within the Force-Level EMC Program. The technical warrant, although assigned to an individual within NAVSEA 05W43, is actually executed by the entire Force-Level EMC Program. This team maximizes the operational performance and safety with respect to E3 and SM in ships and submarines, their combat systems, and shore installations. The key to *enable future naval capabilities* is with well-engineered warfare systems. This is accomplished through a disciplined, upfront systems-engineering effort. Upfront engineering embodies the review of acquisition documents (initial capabilities documents (ICDs), capability development documents (CDDs), capability production documents (CPDs),



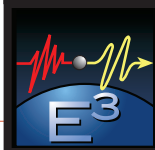

or capstone requirements documents (CRDs)). To ensure EMC for new systems introduced into the fleet, NAVSEA executes its review of ship change documents (SCDs) and ensures that systems attain SC. NAVSEA ensures the performance and readiness of current naval systems, and that platforms are “ready to fight” by executing shipboard EMC and RADHAZ certification and the submarine pre-deployment EMC survey, and by providing direct fleet and PM support.

Historically, a large number of programs encounter issues without E3/SC upfront systems engineering support. E3/SC input can contribute to

- Equipment Specifications
- Equipment Change Proposals
- Ship Alterations
- Test Specifications
- Test Reports
- ICDs
- CDDs
- CPDs
- CRDs
- E3 specifications and standards

Test and evaluation master plans (TEMPs) are also reviewed to ensure that E3/SC requirements from the CDDs and CPDs are properly translated into test and evaluation requirements. E3/SC personnel perform EMC validation of system specifications required for the deployment of new systems and the continued operability of existing systems. In order to ensure good radio-frequency SM, frequency certification documents are reviewed.

The NAVSEA team exercises technical authority by holding formal TWH reviews, thereby enforcing E3/SC acquisition policies and providing E3/SC technical SME/guidance. The team initiates discussions with the PEOs, by pursuing E3/SC involvement with individual programs to implement process improvements. The team also communicates to PEOs for endorsement of SEA 05W43 upfront E3/SC efforts.

SHIP CHANGE DOCUMENTS (SCDs)

SCDs are reviewed for possible EMI/EMC and Frequency Allocation concerns. SCDs that pose an EMC and/or a spectrum concern are reviewed in detail with various SMEs to conduct risk assessments. Based on this assessment, a recommendation to move forward or reject the SCD is made by NAVSEA 05W43 to the SHIPMAIN Technical Assessment Team (TAT). In order to accomplish these efforts, the NAVSEA team actively coordinates with the program offices submitting the SCD in order to obtain additional information and clarification and, when applicable, provide EMC guidance.

The SCDs were born under the SHIPMAIN, or Ship Maintenance Process. It is said that the shortest distance between two points is a straight line. In the world of ship maintenance, many sailors would tell you that the distance between identifying that something that needs to be fixed, and something actually getting fixed, is anything but. However, a new set of maintenance practices was introduced (2002) on the waterfront that shortens the distance between those two points and gives sailors more say in what and when things get fixed. These practices are part of SHIPMAIN, a Navy-wide maintenance



saving lives, capability, money, readiness, and performance. A disciplined systems engineering approach helps address potential issues at the earliest possible stage. This process includes assisting the PEOs/PMs with establishing the proper E3/SM requirements, integrating these requirements into their acquisition and design documentation, and ensuring adequate E3 testing for the resulting shipboard systems, platforms, and shore-site equipment installations.

The NAVSEA team supports the PMs with EMC acquisition engineering and analysis in the review of a wide variety of documentation to ensure E3 and SC have been properly addressed. Documents reviewed include:



users of the spectrum, it is essential that spectrum-dependent equipment and other intentional radiators, including identification devices and stock control micro strips, comply with spectrum usage and management requirements.

Use of the EM spectrum by DoD is expanding based on emerging, advanced technologies and joint warfighting strategies. DoD employs a large number of weapon systems in executing military missions, and most, if not all, depend upon the EM spectrum. Loss of spectrum access, however, has the potential to derail efforts to exploit available technology. DoD is provided access to the spectrum by the federal government and shares the spectrum with other federal agencies, local governments, and private industry. Consequently, DoD must demonstrate critical needs in order to maintain specific portions of the spectrum for exclusive use. This is truer now more than ever before, considering the wide use of wireless technologies in the marketplace.

Spectrum use is governed by international agreements and national laws since DoD operations are conducted worldwide, bringing new challenges to efforts involved in planning and coordinating joint missions. Relocation of systems to new bands is difficult and costly because equipment may interact with other equipment. In addition to the increased likelihood of operational EMI because of overcrowding in the remaining spectrum, equipment redesign, additional testing, recertification for spectrum use, and training all may be necessary. Further domino effects are also likely, forcing changes to other parts of the integrated military system. Many frequencies used by DoD are those that work best for the intended purpose, dictated by the laws of physics. DoD efforts to safeguard needed spectrum access depend on the capability to demonstrate the criticality of targeted frequencies. The acquisition community plays a key role since the data generated during the SC process provides much of the information needed to substantiate DoD positions.

The NAVSEA Team helps the PM to attain SC, which is obtained by completing the required documentation, Application for Equipment Frequency Allocation (DD Form 1494). The form must be completed and submitted for each acquisition development stage, which coincides with the DD-1494 Stage Levels (1–4), for all RF spectrum-dependent systems, active and/or passive, including commercial off-the-shelf (COTS) equipment. The NAVSEA team has established safeguards to ensure that SC is obtained before assuming contractual obligations for system development and

initiative that builds a more effective and efficient maintenance system as the CNO lays out the FRP, the Navy's roadmap to a surge-capable force.

SHIPMAIN specifically examines the planning processes for surface ship maintenance, from the point where ship's force first identifies the work, through the point when sailors begin turning the wrenches.

Vice Admiral Phillip Balisle, former Commander, Naval Sea Systems Command, said, "As we look ahead to the Navy of the 21st century, a fleet of ships ready to surge and respond at a moment's notice, operated by optimally manned crews of highly skilled and trained sailors, we need an improved maintenance system to support that fleet." He went on to say, "SHIPMAIN is the kind of process change we need that addresses today's problems and lays the foundation for tomorrow's Navy."

SPECTRUM CERTIFICATION

The availability of an adequate spectrum to support military electronic systems and equipment is critical to maximizing mission effectiveness. Spectrum planning and management must be given appropriate and timely consideration during the development, procurement, and deployment of military assets that utilize the EM spectrum. To ensure maximum EMC among the various worldwide

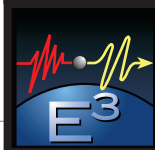

demonstration, production, and deployment and/or procurement of any communications-electronic (C-E) equipment, including COTS.

As stated previously, “the key to *enable future naval capabilities* is with well-engineered warfare systems.” The NAVSEA team executes the upfront system engineering process with a focus on acquisition documents, SCDs, and SC. In the past year, the NAVSEA team has provided technical support to a large number of systems and next-generation platforms, including (but not limited to):

- Participated in USS *Virginia* (SSN 774), USS *Gerald R. Ford* (CVN 78), DDG-1000, and Aegis Modernization (AMOD) COTS Refresh Three (CR3) TWH reviews.
- Participated in Joint High Speed Vessel (JHSV), Littoral Combat Ship (LCS), P-8A Multimission Maritime Aircraft (MMA) Electronic Support Measures (ESM), Electromagnetic Aircraft Launching System (E-ALS), AN/SPS-74 Periscope Detection Radar (PDR), and Sea RAM program reviews.
- Reviewed 21 (subs) and 35 (surface) specifications, technical documentation, or waivers and provided feedback to PM/PEO/PMS codes.
- Supported the Commander, Operational Test and Evaluation Force (COMOPTEVFOR) by providing E3 subject-matter expertise in the C4ISR design evaluation phase of the DDG 1000 Operational Assessment (OA).

Team Deliverables included:

- Published technical pyramid identifying key competencies and technical knowledge of assigned EA and technical leads.
- Provided presentations discussing E3 issues and risks associated with bringing new technologies to ships/subs to 12 key S&T meetings.
- Successfully EMC-certified 24 ships and RADHAZ-certified 45 ships.
- Published biweekly (SCDs) and monthly Joint Capabilities Integration and Development System (JCIDS) status reports of technical reviews completed.
- Published (14) biweekly reports discussing significant TWH issues and Technical E3/SS/EMP issue resolutions.
- Reviewed and provided concurrence to PMS 450 on USS *Virginia* (SSN 774)-class EMC Control Plan.
- Reviewed and provided nonconcurrence to SEA 05V on the Northrop Grumman Newport News request to eliminate the EMP test

requirement from the CVN 78 Ship Specification Section 400.

- Combined NAVSEA INST 2450.1/2450.2 and issued NAVSEA INST 2400.20 E3/Spectrum Supportability Policy for Review (September 2007 and April 2008).

Ongoing team activities include:

- Investigating development of EMC and RADHAZ certifications for submarines.
- Utilizing SCD/JCIDS reviews as a means to train PMs/PEOs on the proper development and adherence to E3/SS policy requirements.
- Providing E3/spectrum leadership to USS *Virginia*-class and USS *Gerald R. Ford* (CVN 78) Electromagnetic Advisory Board (EMCAB).
- Providing E3/Spectrum support to the AMOD COTS Refresh.
- Providing research and analysis of SC for a number of systems planned for DDG 1000.
- Providing technical support to PMS 450, PMS 415, PMS 401, PMS 399, PMS 394, PMS 392, SEA 05U1, SEA 07TC, and PMW 160. [ex. Submarine Local Area Network (SubLAN), Advanced Seal Delivery System (ASDS), T1 Acoustic Media, NextGen Countermeasures, and High-Frequency Transmitter]
- Providing technical support to PEO C4I, PMS 312, SEA 05D, SEA 21/PMS 470, SEA 05V, SEA 05Z, and PEO ships. [ex. Automated Digital Network System (ADNS), HM&E Systems, Commercial Broadband Satellite Program (CBSP), and Joint Biological Point Detection System]

Recently, the Chief of Naval Operations (Admiral Gary Roughead) issued the CNO Guidance (CNOG) for 2009. The CNOG reviews the Navy's major 2008 accomplishments and reaffirms the vision, mission, guiding principles, and focus areas articulated in last year's guidance. The Navy's primary focus areas remain:

- Build the future force—We are building a Navy with the right force structure to deliver capacity and capability to combatant commanders on time and at the right cost.
- Maintain our warfighting readiness—We are the world's dominant naval force, working with our joint and global partners to prevent and win wars.
- Develop and support our sailors and Navy civilians—Our diverse and competent military and civilian force is focused on readiness and underpinned by a Navy ethos.

The CNOG forms the basis for the goals of NAVSEA 05W43 to ensure that we will build the

future force (through an upfront engineering process), maintain our warfighting readiness (through SHIPMAIN), and develop our sailors and Navy civilians.

Harsh EM operating environments and the increasing power of shipboard emitters, coupled with increasingly more sensitive electronics, significantly increases the potential that EMI problems will increase even though we have a significant front-end engineering process. Like other areas of expertise, E3/SM must evaluate emerging technologies in test equipment, test processes, modeling and

simulation, components, and systems. It must also transition viable merging technologies to better identify and correct E3/SM issues, ultimately improving fleet EMC, thereby delivering warfighting capability and mission assurance to the U.S. Navy.

BIBLIOGRAPHY

- OPNAV 2400.20F, Electromagnetic Environmental Effects (E3) and Spectrum Supportability Policy and Procedures, 19 July 2007.
- MIL-HDBK-237D, Electromagnetic Environmental Effects and Spectrum Supportability Guidance for the Acquisition Process, 20 May 2005.



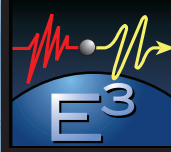

THE IMPORTANCE OF E3 SCIENCE AND TECHNOLOGY IN PREPARATION FOR FUTURE WARFARE

By Lucas Hale and June Drake

Warfare differs significantly today from warfare only a decade ago. A decade from now, it will likely differ even more. Our fighting forces need to be prepared for future conflicts so they can continue to fight, win, and come home safely. That means Naval Sea Systems Command Warfare Centers' scientists and engineers need to actively research, develop, test, and evaluate new technologies, systems, and capabilities today to ensure that tomorrow's warfighters will always have the edge and will never find themselves in a "fair fight" with adversaries.

Science and technology (S&T), as it applies to the military, is the generation and application of new knowledge based on scientific study for the purpose of extending or enhancing U.S. military superiority. This knowledge generation and application function represents a major aspect of the Warfare Centers' identities. S&T not only allows today's naval workforce to develop and deliver technologies to solve warfighter challenges in the field, it strengthens and supports the Warfare Centers' technical capabilities. It also maintains the Warfare Centers' role as the Navy's "smart buyer" in providing an intelligent bridge between technological possibilities and national needs.

The U.S. security environment has changed dramatically since the terrorist attacks of 2001. Consequently, the defense community must continually adjust and adapt. Moreover, a never-ending need exists to rapidly insert innovative and emerging technologies to meet the immediate and evolving needs of national security. This can be accomplished only through aggressive teaming across the Warfare Centers and with other services, industry, and academia. As new opportunities and challenges continue to emerge, it is critical that the Warfare Centers become highly skilled at rapidly locating, developing, and integrating technologies to not only improve existing capabilities, but to also create new capabilities. S&T is at the core of such flexibility.

CURRENT ELECTROMAGNETIC ENVIRONMENTAL EFFECTS (E3) S&T CHALLENGES

S&T efforts pursued at the Warfare Centers are aimed at fulfilling the needs of operational forces. Over the last 100 years, naval forces have grown increasingly reliant on electromagnetic (EM) systems to ensure mission success. The force relies on EM effects to communicate and share information, search for and engage targets, land aircraft, handle cargo, and perform many other functions. The operational EM environment



mission environments. The utility of EM systems has proven so great that current operations would cease without their functionality.

Shipboard Complexity

U.S. Navy ships field the most powerful mobile EM systems in the world. These ships are also self-contained “floating cities” that carry the myriad provisions, sailors, equipment, and military assets required for mission completion. Because of the physical limitations of each platform, the shipboard environment quickly becomes congested, especially as related to the EM environment. Consider the example of *Nimitz*-class aircraft carriers (see Figure 1), which field roughly 150 EM systems topside. Due to the aircraft launch, retrieval, and

handling requirements of such a ship, most of these EM systems are relegated to compressed spaces on the island, aft tower, mast, or along the flight-deck edge. Other ships have similar restrictions on topside real estate allocated to EM systems. As new systems are developed, they are added to the already congested topside spaces. One role of topside design is to ensure that these EM emitters and receivers functionally coexist as much as possible. This task is not easy; the fixed real estate and increasing EM system load means that U.S. Navy platforms are *the* most complex EM assets in the world.

This complex EM environment requires that a great deal of effort be paid to exploring the interactions among emitters, receivers, and other devices. EM systems can impact personnel safety, fuel, and ordnance by coupling to devices or structures, causing inadvertent initiation or burns. The



Figure 1. *Nimitz*-Class Nuclear Aircraft Carrier

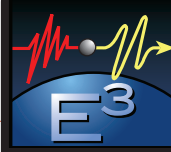

pervasive nature of EM systems on ships, coupled with the inability to gain relief through physical separation, requires that the Navy exercise expert judgment in EM system safety and compatibility. Every system onboard ship must be certified for safety to include a series of Electromagnetic Interference (EMI)/Electromagnetic Compatibility (EMC) tests, such as Hazards of Electromagnetic Radiation to Ordnance (HERO). Below decks spaces, such as ammunition storage lockers and helicopter bays, are also areas of concern as they are becoming filled with wireless communications and inventory systems such as WiFi and Radio Frequency Identification (RFID), respectively. The increased RF emissions in these spaces can generate potentially hazardous conditions as ordnance is staged and moved through the spaces. Advanced testing methods for characterizing below decks spaces, such as mode stirred chamber testing, are essential to ensuring ship safety now and in the future.

Mission Requirements

As outlined in *A Cooperative Strategy for 21st Century Seapower*, U.S. maritime forces must conduct operations across missions spanning major combat operations (MCO); asymmetric warfare; and stability, security, transition, and reconstruction (SSTR).¹ Success in these missions requires heavy reliance on collaborative engagement between U.S. and allied forces, often in close proximity (see Figure 2). Bringing these units together, each with their own complex EM environment, results in an even more stressing EM environment. Not only do the platforms need to ensure operability of their own systems, but the group must deconflict within itself to ensure that the group as a whole is compatible.

The evolving nature of warfare and the mission set described above have expanded the operational domain of U.S. maritime forces. In order to effectively prosecute present and future naval missions, U.S. maritime forces must move beyond



Figure 2. A Collection of Platforms Increases E3 Environment Complexity

blue-water operations into the littorals, land, and cyberspace. As platforms and collections of platforms move closer to land, the EM environment increases in complexity due to terrestrial emitters interfering with naval systems, and vice versa. These terrestrial systems are often part of the civilian infrastructure, but they can also consist of enemy and allied systems. Figure 3 provides a notional illustration of these challenges.

Government policy also plays a role in the EM environment. Since the 1993 Omnibus Budget Reconciliation Act gave the Federal Communications Commission the authority to auction segments of the U.S. EM spectrum, 85 such auctions have taken place. Coupled with the negative political ramifications of unintended EM interference, these spectrum auctions have resulted in the military bands being squeezed on all sides by commercial allocations, resulting in degraded capabilities, more system risk, and increased need for frequency deconfliction. Operating effectively in this constrained environment is an additional challenge facing our warfighters that requires the E3 community to pursue innovative S&T solutions.

FUTURE E3 S&T CHALLENGES

The future poses unprecedented challenges for the E3 community. Next-generation naval platforms are fielding novel systems that rely on EM effects in unprecedented ways. Proper S&T is essential to ensure these systems operate as expected.

Advanced radars currently under development, such as AN/SPY-3, are expected to bring order of magnitude increases in power to the shipboard environment within a decade. The E3 community is presently focusing S&T efforts on developing methods for analyzing and testing these new systems to ensure ship safety and EMC. Additional understanding of next-generation systems is required in order to accurately model apertures, propagation, signal processing, and interferences. Testing must be completed in conjunction with the research and analysis to gather the data and insight required to validate the models developed. New instrumentation and methodologies must be pursued to collect, store, and analyze the data. Unless S&T is conducted concerning the analysis and testing for next-generation EM systems, future fleet operations, weapons, flight, and combat system safety could be impacted across all major programs.

Directed energy (DE) and high-power microwave (HPM) weapons use EM energy to achieve effects on target. Their employment will fundamentally change the landscape of naval engagement, as effects will be delivered at the speed of

light and with tunability. These weapons will come in many shapes and sizes, such as the Laser Weapons System (LaWS) and the Active Denial System (ADS). To field such systems, the Warfare Centers must conduct S&T to ensure understanding of effects on target, shipboard integration, atmospheric propagation, and other factors. Once operational, these weapons will provide naval forces with flexible engagement options necessary for effective operations across future SSTR, asymmetric, and MCO missions.

Along with new directed-energy weapons, integrated power supplies (IPS) capable of running them will be needed. The design of IPS requires S&T expertise in power generation, storage, conditioning, and control. The IPS will generate its own EM effects that will need to be assessed for interference with other below- and above-deck systems. Additionally, DE weapons will create additional EM fields that will need to be minimized or controlled to acceptable levels for ordnance and personnel. Again, this will require advanced techniques in testing and analysis.

All design, development, and mitigation techniques and tools for the shipboard environment are also being applied to support the joint and coalition forces operating in complex EM environments. The war in Iraq has demonstrated the need for agility in fielding technologies to defeat the improvised explosive device (IED) threat. Novel EM-based solutions have been identified and fielded throughout the war, saving the lives of the U.S. and allied forces, Iraqi civilians, and police. S&T efforts must continue to identify and exploit EM means for achieving desired effects. Without a strong S&T backbone, the viability of future U.S. military forces will be in jeopardy.

Preventing Technical Surprise

Technological surprise occurs when an adversary develops a technology that provides a revolutionary capability. Instances of technological surprise often destabilize existing balances of power and change the competitive landscape among nations. Historical examples of technological surprise include the development of the atomic bomb, submarines, aircraft carriers, amphibious warfare, strategic bombers, intercontinental cruise missiles, and satellites. S&T was critical in the development of each of these destabilizing developments, and it continues to be the first step in developing any new capability.

The above technologies are taken for granted today due to their history of employment. For example, aircraft carriers have been employed for

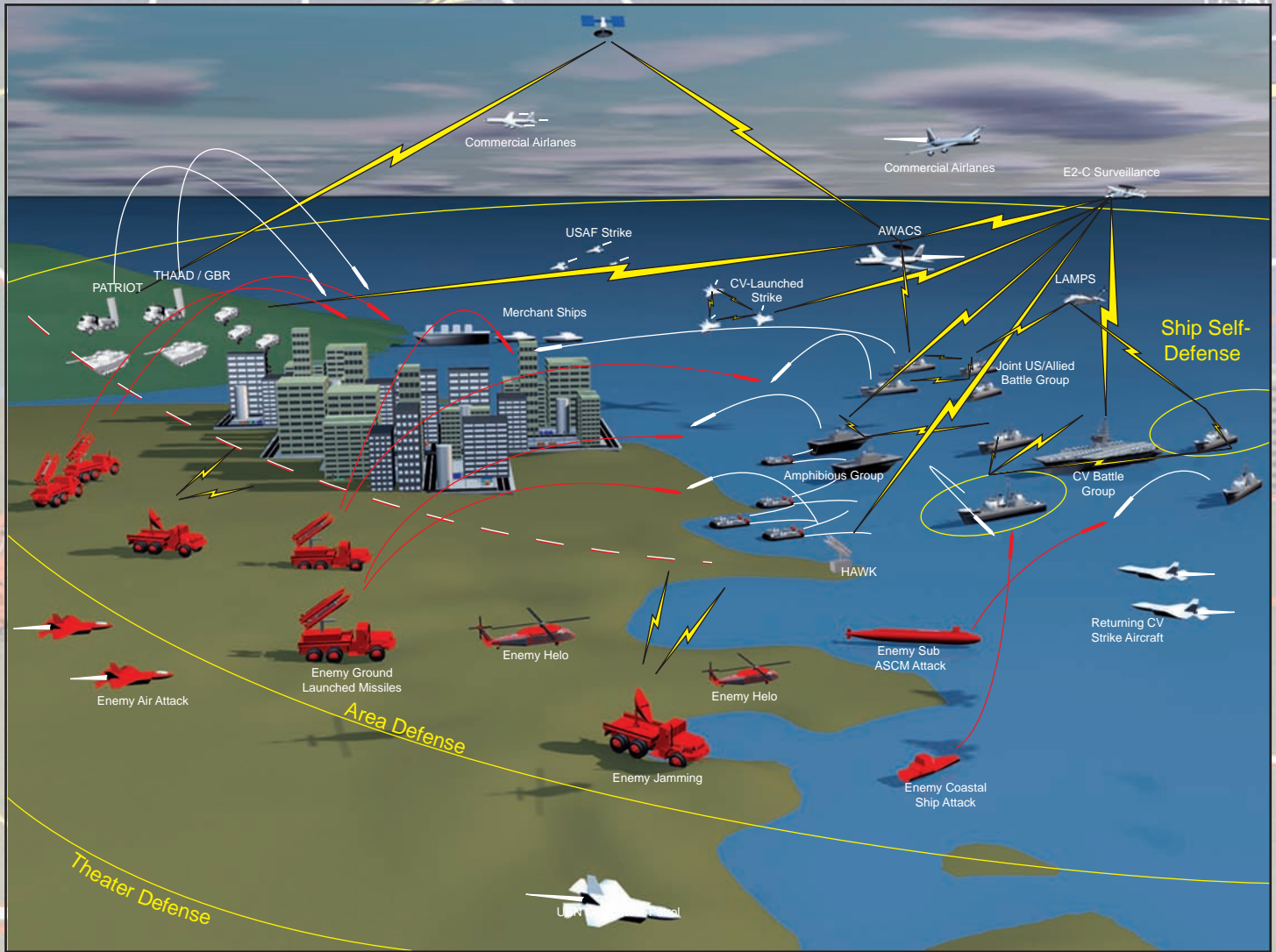

Figure 3. The Present Electromagnetic Environment

Enemy Helo
Enemy Ground -
Launched Missiles

Enemy Air Attack

Area Defense

over 90 years and submarines for 233 years. But when they were first developed, each allowed its creator to exercise control over competitors in new ways. If atomic bombs and satellites are the technological surprises of the past, what are the surprises of the future?

The pursuit of S&T by the Warfare Centers reduces the probability of technological surprise. If a new technology is developed by a foreign power, our strength in S&T allows us to rapidly study and understand the mechanisms being used, and to develop our own defenses and countermeasures.

Further, we must always strive to be the ones introducing the element of technological surprise to the fight. For these reasons, it is essential that the Warfare Centers invest in S&T, not only in E3, but in all areas of military importance. To neglect S&T for short-term goals is nothing short of mortgaging the military future of the United States. This is a risk we must not accept.

REFERENCE

1. Conway, J.; Roughead, G.; and Allen, T., *A Cooperative Strategy for 21st Century Seapower*, October 2007.

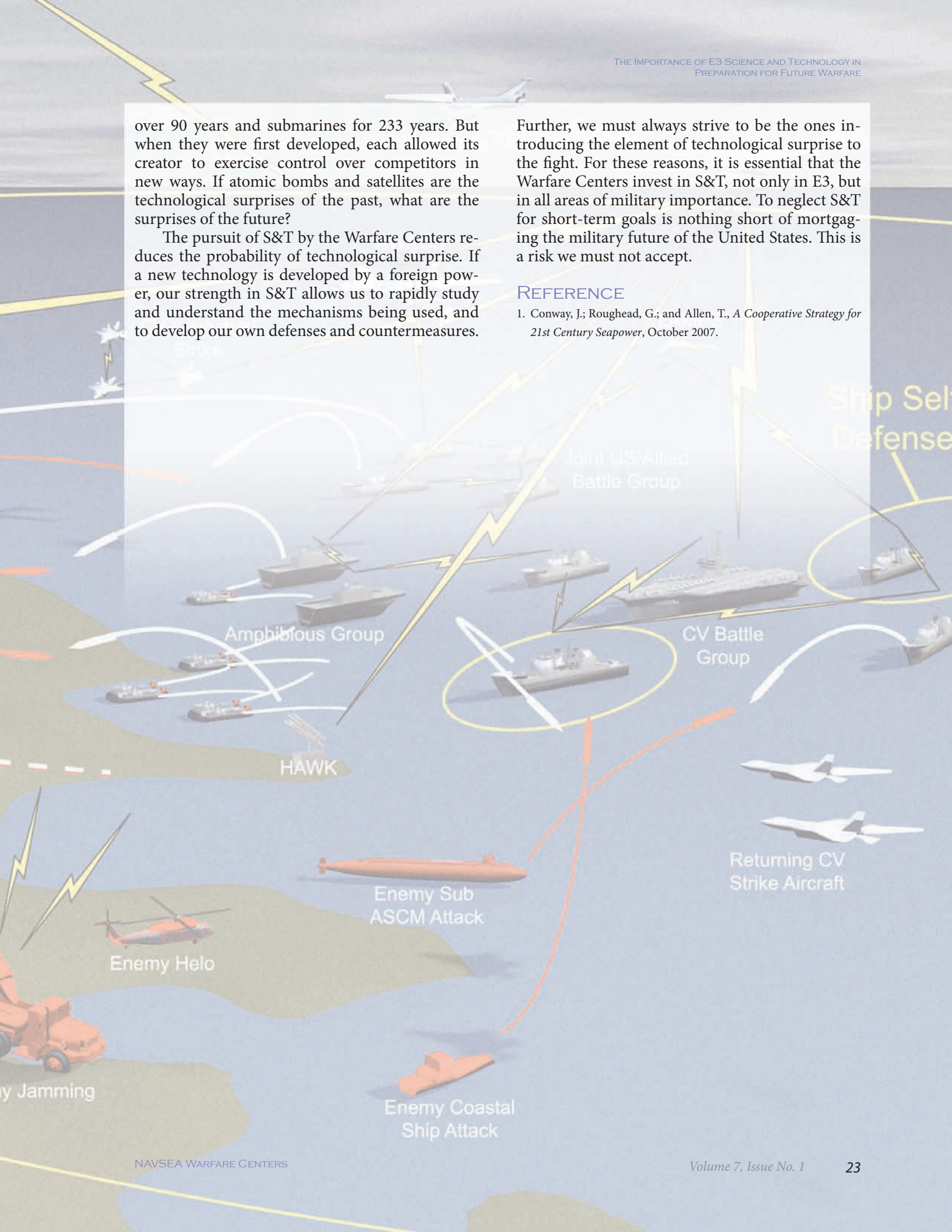



A SHORT HISTORY OF NSWC DAHLGREN'S INVOLVEMENT IN THE SHIPBOARD ELECTROMAGNETIC COMPATIBILITY IMPROVEMENT PROGRAM

By George Winters

The Navy's first wireless message was transmitted from USS *New York* (CA 2) to a naval shore station in Navesink, New Jersey, in November 1899.¹ In his report dated 1 October 1900, R. B. Bradford, Chief of the Bureau of Equipment, stated that the results of these early experiments were very favorable. However, one serious defect was noted in the usefulness of the Marconi system of wireless telegraphy. This defect was referred to as "interference" and was described as follows:

When signals are being transmitted from one station to another, as between USS *New York* and the Highland Lights, for instance, and another vessel comes within signaling distance and attempts communication with the Highland Lights, then the signals from the two ships become confused, and the receiving station on shore is unable to distinguish between them.²

The two ships were USS *New York* and USS *Massachusetts* (BB 2).³ At the time, each ship was equipped with a single wire antenna and a wireless telegraph apparatus. The interference was caused by the fact that all transmitters and receivers operated at the same frequency. The transmitters had a very broad spectrum content. The frequency of the radio frequency (RF) energy being radiated was simply dependent on the length of the

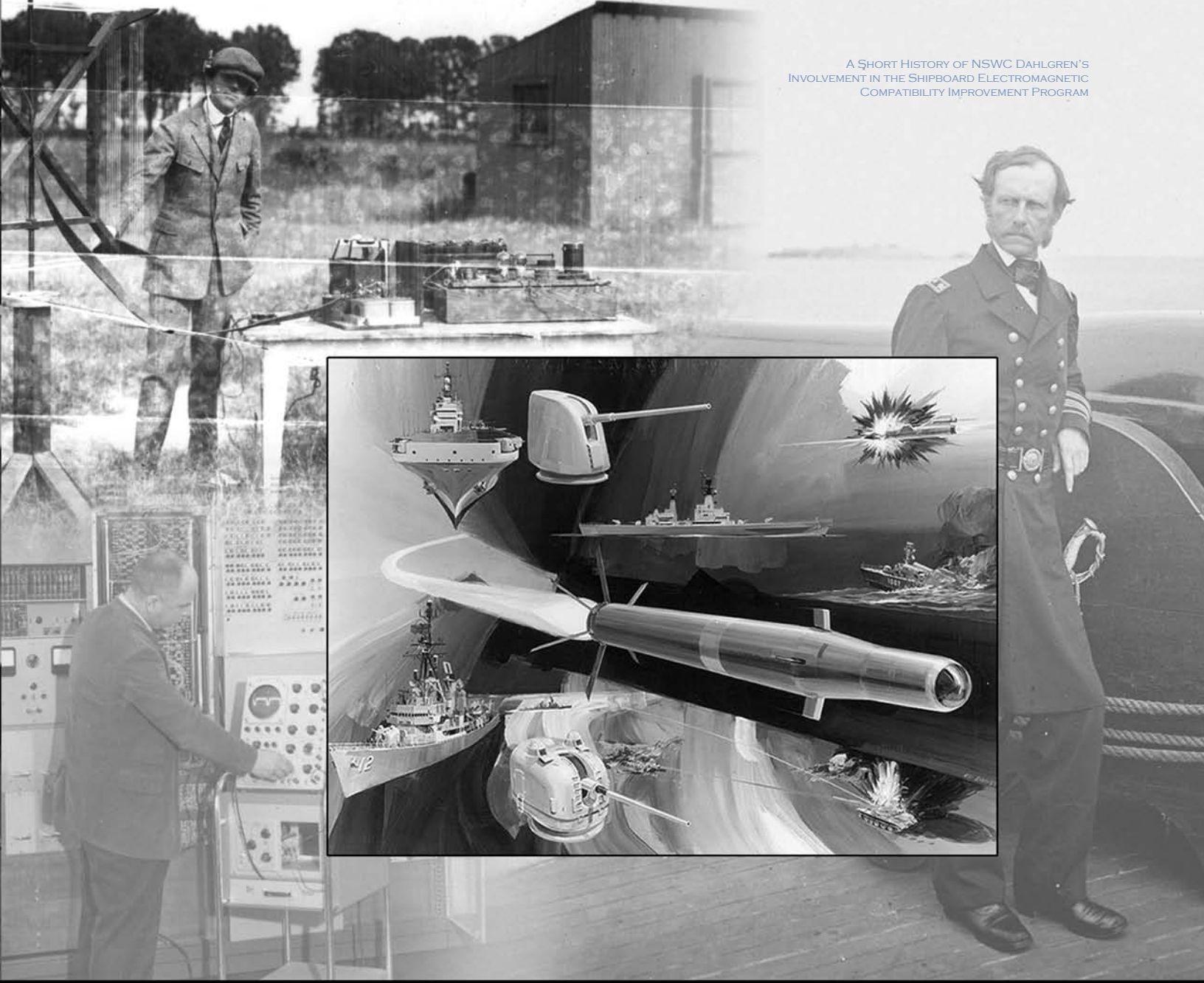

antenna. A photograph of USS *New York* is shown in Figure 1.

The U.S. Navy quickly embraced this new wireless technology. No longer was a ship out of communication range when it sailed over the horizon. Beginning in 1902, all new Navy ships were expected to have provisions for installing a wireless telegraph apparatus. In 1904, the Navy began constructing a global broadcasting network.¹

During these early years, interference continued to be mentioned as a problem in Annual Reports of the Navy Department and was one of the factors considered in determining what wireless apparatus would be adopted by the Navy. The *Annual Reports of the Navy Department for the Year 1905* notes:

Comparative tests of apparatus furnished by a number of wireless telegraph companies have

been made, particular attention being given to methods of secrecy in sending, and prevention of interference with messages being sent; also to ascertaining the relative value of the various systems.²

For the next 80 years, the number and types of shipboard electronic equipment using the RF spectrum proliferated at a seemingly ever-increasing pace. As the shipboard electromagnetic environment became more complex, there was a corresponding increase in the number of shipboard Electromagnetic Interference (EMI) problems. Today, EMI is defined as any electromagnetic disturbance that interrupts, obstructs, or otherwise degrades or limits the effective performance of electronics/electrical equipment. Electromagnetic Compatibility (EMC) is defined as the ability of all



Figure 1. USS *New York* (CA 2) taken in the Summer of 1898. The wireless system's antenna ran from a wooden mast mounted on the topmast to the after gun room. (Navy Historical Center Photograph)

equipment, systems, and platforms to operate in their intended operational environments without causing or suffering unintentional performance degradation or harmful reactions as the result of EMI.

In 1973, the Naval Sea Systems Command (NAVSEA) recognized the need to mitigate EMI aboard its ships. It established a small team of highly skilled specialists to test, evaluate, and correct shipboard EMI problems. The program was called the Shipboard Electromagnetic Compatibility Improvement Program (SEMCIP). The Naval Surface Warfare Center, Dahlgren Division (NSWCDD) was part of this original team of specialists. NSWCDD assumed the responsibility for resolving shipboard radar-related EMI problems and assigned one engineer to provide part-time support to SEMCIP.

Due to the increased visibility brought about by the Board of Inspection and Survey (INSURV), the Navy as a whole began to recognize that the operational readiness of ships, submarines, and aircraft were being significantly impacted by EMI. Something needed to be done. In 1978, a Chief of Naval

Operations Executive Board (CEB) was stood up to address the "Management and Control of Electromagnetic Interference." In a CEB briefing given in 1980, Dr. Robert J. Haislmaier, Electromagnetic Spectrum Management Branch, Naval Communications Division of the Office of the Chief of Naval Operations, identified three EMI control programs that were making a difference in the fleet's EMI posture by correcting EMI problems. These were SEMCIP and two new startup efforts: NAVSEA's Waterfront Corrective Action Program (WCAP), and Naval Air Systems Command's Air Systems Electromagnetic Interference Corrective Action Program (ASEMICAP).³

Between 1973 and 1978, NSWCDD assumed a much greater role in SEMCIP. It was on its way to becoming the technical and programmatic lead for addressing Electromagnetic Environmental Effects (E3) issues on surface ships. During these 5 intervening years, the program had grown from one engineer to six. Accordingly, NSWCDD continued to provide technical leadership for shipboard radar EMI problem resolution. NSWCDD also began working with several NAVSEA radar program

managers to ensure that EMC was being built into new systems. A new Electronic Warfare (EW) system called the AN/SLQ-32 (see Figure 2) was being introduced into the fleet. Since the AN/SLQ-32 was both experiencing EMI problems from and causing problems to shipboard radars, NSWCDD EMI mitigation efforts expanded to include both radars and EW systems.

In the late 1970s and early 1980s, NSWCDD also began supporting a SEMCIP initiative to develop an E3 knowledge management system infrastructure. The goal was to provide a way of getting E3 information to ships and fleet support activities, where it could have a positive impact on fleet readiness. SEMCIP began by creating a number of E3 training guides. Six were published between 1977 and 1982. The two most popular were *The Commanding Officer's Guide to the Shipboard Electromagnetic Environment* (1977) and *The Electronic Materials Officer's Guide to Shipboard Electromagnetic Interference Control* (1978). The Commanding Officer's (CO's) guide was intended to provide the ship's Commanding Officer and Executive Officer with an understanding of the causes and effects of EMI problems typically found aboard their ships. The Electronic Materials Officer's (EMO's) guide was designed to complement and expand on the information provided

in the CO's guide. It provided more detailed information, based on SEMCIP "lessons-learned," on how EMI could be successfully controlled aboard ship. While the CO's guide is no longer being published, the EMO's guide is still being updated and reissued. The latest version will be published later this year.

During the same time SEMCIP was developing E3 training guides, SEMCIP was also looking for a way of capturing and preserving EMI information in a centralized manner. This initiative was known as the SEMCIP Management Information and Tracking System (SMITS). SMITS consisted of several distinct, but interrelated series of computer files storing E3 information. Periodically, or on demand, the stored information would be pulled from the files and used to generate 1 of 10 standard reports. For example, a listing of the top 100 shipboard problems was generated each quarter; a master EMI problem index was generated semiannually; and a ship activity summary was prepared annually. While SMITS was originally conceived to provide E3 information to the Navy's design and acquisition managers, it also served to provide E3 information to all SEMCIP and Navy E3 Program participants. It tracked all SEMCIP technical reports, briefings, messages, and other E3-related material, and allowed originally micro-

fiched documents to be retrieved from an associated SEMCIP library.

In the 1982 and 1983 time frame, two events occurred that added new urgency to the Navy's EMI control efforts. The first was the sinking of HMS *Sheffield* during the Falkland's War by an Argentine aircraft. HMS *Sheffield* was widely reported to have been sunk due to an EMI problem. The ship's radars were reported to be effectively disabled when permission was given to transmit messages back to London using its satellite communication system.⁴

The second event was a series of letters from Rear Admiral J. B. Bulkeley, President, INSURV. One was a personal letter to Rear Admiral J. D. Beecher, Assistant Deputy Commander



Figure 2. AN/SLQ-32 Antenna Enclosure

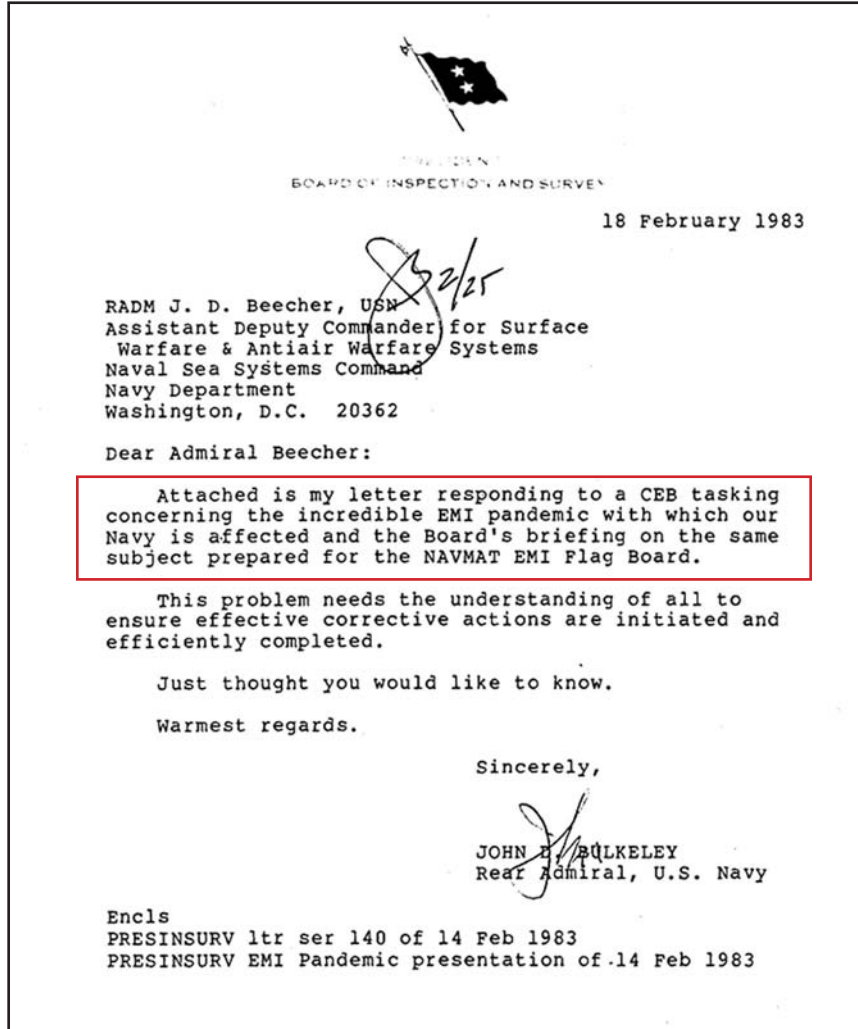

Figure 3. Letter from the President of INSURV dated 18 February 1983

for Surface Warfare Systems, NAVSEA. The leading paragraph of this letter is shown in Figure 3.

In the enclosure to this letter, RADM Bulkeley noted,

“The Board has frequently underscored the apparent lack of system engineering at the ship and warfare levels when commenting upon fleet EMC deficiencies. The Board recommends that the Chief of Naval Material establish an effective in-house EMC engineering capability that can address EM system performance issues during the entire life cycle of new ships and existing fleet ships.”

Attached to this enclosure was a prioritized listing of 34 unresolved EMI deficiencies. Twenty-four of these deficiencies were identified as impacting the

ship’s ability to perform its mission. Ten additional EMI problems were noted, but were not considered to be degrading ship performance.

In December 1982, Dr. Haislmaier—the man recognized as being the founder for the present-day Navy E3 Program and the man after which the Navy’s Haislmaier Award is named—laid out his vision/goal for the Navy’s EMI Control Program. It was to “institutionalize EMC/EMI control in the Navy.”⁵ He proposed five objectives to meet this goal; they were:

- Do it right the first time
- Make it work right if it doesn’t
- Use it right
- Keep it working right
- Support these efforts with needed technology

Today, Dr. Haislmaier's vision lives on. The requirement for a centralized or core Navy E3

program called “SEMCIP” was recently reconfirmed in the latest Chief of Naval Operations Instruction, *Electromagnetic Environmental Effects (E3) and Spectrum Supportability Policy and Procedures*.⁶ The instruction assigns responsibility for maintaining this core Navy E3 capability for fleet and shore facilities to NAVSEA. NAVSEA, in turn, assigned this responsibility for surface ships and strike groups to the Electromagnetic Effects Division at NSWCDD.⁷

In 1983, INSURV identified 24 EMI deficiencies that were degrading ship mission capabilities. Today all of these originally 24 deficiencies have long since disappeared. Of the 10 nonmission degrading EMI problems, only 2 can still be found aboard ships today. NSWCDD played a key role in resolving the majority of these problems on surface ships. Since 1983, the number of antennas aboard surface ships has roughly doubled. The electromagnetic environment has become even more complex. EMI is still a problem but is no longer discussed as a “pandemic” problem. Over the last 30 years, the Electromagnetic Effects Division at NSWCDD can claim much of the credit for mitigating EMI aboard surface ships and for helping to implement Dr. Haislmaier’s vision for the Navy.

REFERENCES

1. Preston E. Law Jr., *Shipboard Antennas*, 2nd Edition, Artech House Inc. 1986.
2. <http://early.radiohistory.us/navy1.htm>.
3. Dr. Robert J. Haislmaier, *Electromagnetic Interference (EMI) Control Status Report*, (Office Of The Chief Of Naval Operations Serial 090X/073XB, 4 April 1980).
4. “British Error Tied to Warship Sinking,” *The San Diego Union*, Friday, 30 July 1982.
5. *EMI Pandemic Issue Paper* by Dr. R. Haislmaier, OP-941F, dated 9 December 1982.
6. Chief of Naval Operations Instruction 2400.20F, *Electromagnetic Environmental Effects (E3) and Spectrum Supportability Policy and Procedures*, dated 19 July 2007.
7. *Memorandum of Agreement Between Deputy Commander for Warfare Systems Engineering*, Sea 06 Director, Battle E3 Engineering and Spectrum Management SEA 62E, and Commanding Officer NSWCDD, Code J50, dated 5 May 2004.

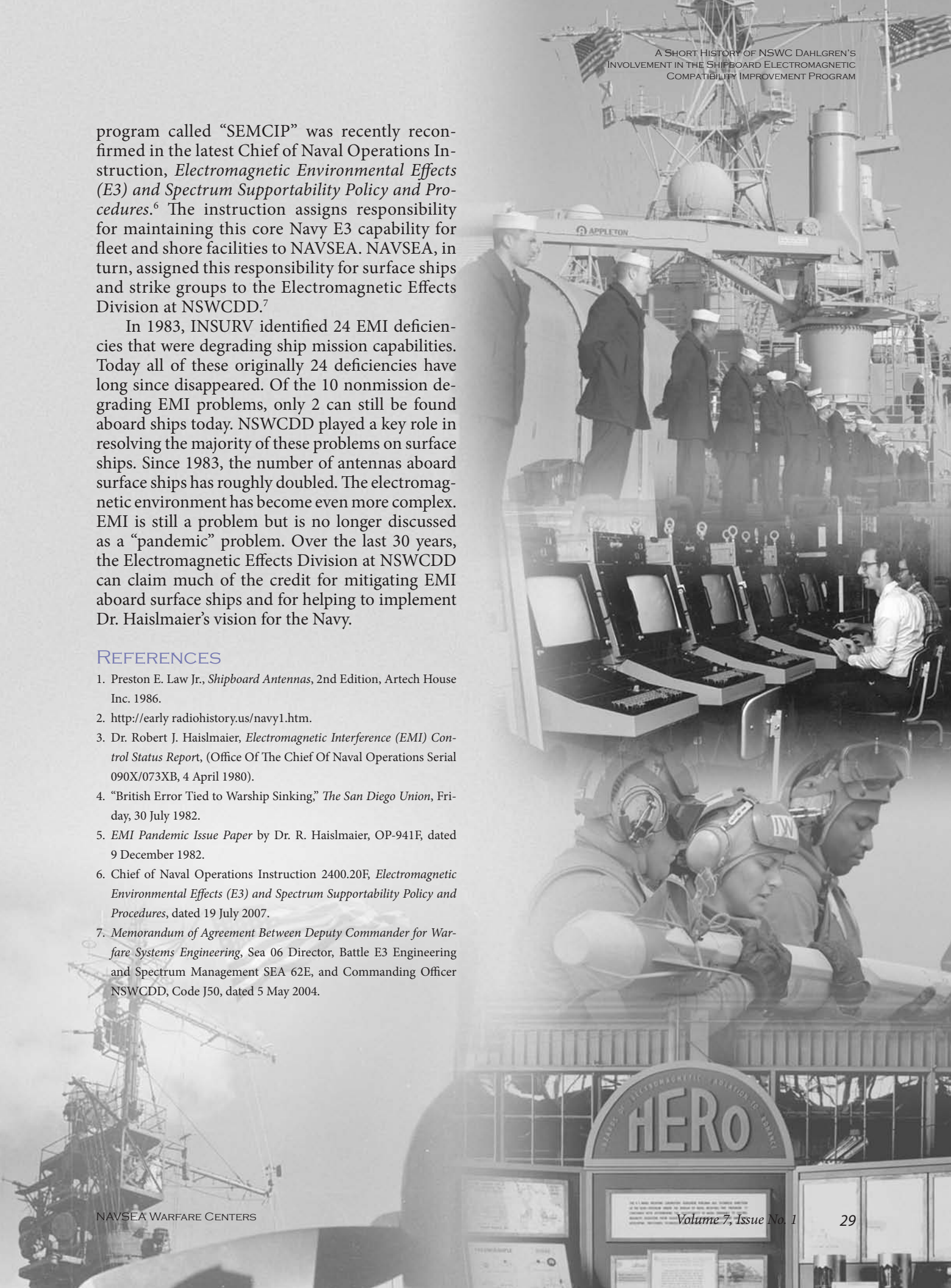



SPECTRUM MONITORING FOR THE FLEET

By Jonathan Vick, Jeff Acree, and Bruce Naley

INTERFERENCE PROBLEMS

The same story plays out time after time. Be it from a cable TV or cellular phone provider, or even a formal protest from a foreign country—another accusation of radio frequency (RF) interference attributed to a U.S. Navy system is again reported. The U.S. Navy and its powerful radars and communications systems are constantly on the move and occasionally interfere with other spectrum users. In the early 1990s, chronic Navy to commercial radio frequency interference (RFI) problems in the Caribbean climaxed with a Navy training exercise being accused of ruining most of a Superbowl broadcast for the entire island of St. Thomas. After that, a permanent banner appeared on St. Thomas Cable to inform the public that ANY picture quality issues were likely due to the U.S. Navy and complaints should be directed thereto. This obviously created problems and a great deal of additional work for Navy leadership. At other times, the Navy is its own victim, with one unit interfering with another.

The Navy develops and uses detailed frequency plans that direct all the frequencies and channels each Navy system should use. These plans are optimized by the Afloat Electromagnetic Spectrum Operations Program (AESOP) to reduce or eliminate interference. However, sometimes either the plans are not followed, operators make ad hoc “modifications” to plans due to equipment casualties, or the plans are not updated as the situation changes.

Ships are not the only naval assets that have to deal with RF interference issues. Consider test ranges like the Pacific Missile Range Facility (PMRF) that tests ballistic missiles. These are very expensive and potentially dangerous tests. Quite a lot depends on the RF commands and telemetry between the missile and the ground controllers operating properly, especially the special frequency and command set used to self-destruct the test missile if something goes wrong. Even though test sites are chosen for their remoteness, there is always the potential for some amount of commercial or pleasure boat traffic in the vicinity. Then, there is always the possibility that with all the different test facilities on site, some of their own emitters might be turned on accidentally.

Currently, the Navy is ill-prepared to defend itself when falsely accused of interfering with civilian commercial interests. In the above Caribbean example, word of Navy interference spread to other services beyond cable TV providers—even in frequency bands where the Navy was not operating. In the absence of a robust means to police the spectrum, it took too long to locate interference sources and then determine and prove the Navy’s innocence. Because it could not prove otherwise, the Navy became

the scapegoat for all electromagnetic interference problems in that part of the Caribbean, whether caused by the Navy or not.

As a result of these types of incidents, a number of questions surfaced, such as: How can the Navy police itself to ensure compliance with its own frequency plans and protect itself and others from Navy-created interference? How can the Navy protect itself from RF interference caused by others? How can the Navy prove to others what it is and is not transmitting? In answering these questions, the first step is ensuring that the Navy is aware of all (i.e., self-generated and third party) RF emissions in the environment. In a phrase—spectrum monitoring—should occur, with the goal of identifying and addressing frequency conflicts before any system degradation occurs or, at a minimum, very shortly after it is reported.

The goal of spectrum monitoring reflects the intent of the Department of the Navy's (DON's) electromagnetic spectrum policy.¹ It states:

- The DON shall continually strive for efficient spectrum use.
- The DON must ensure that available spectrum is efficiently utilized to provide the greatest benefit to the overall DON mission.
- The DON shall apply sound engineering and administrative practices throughout the Department to ensure effective and prudent use of electromagnetic spectrum.
- The DON should maintain its pre-eminence in identifying and evaluating new techniques for efficient spectrum use that could potentially benefit the Navy and/or the Marine Corps.

Not only do these mandates require that each emitting system be spectrally efficient, but when many systems are operating in close proximity, their use must be coordinated to ensure that the overall spectrum is being used to the maximum benefit of the Navy mission. If one system interferes with the spectrum another system is using, or is assigned a frequency where third party interference exists (when perhaps an alternate usable frequency is available and interference-free), then the total available spectrum is not being used efficiently. Having an optimized frequency plan and a means to verify its implementation, enforce its use, and adjust when needed is one way the Navy can adhere to the precepts of the SECNAV policy.

NSWC Dahlgren has been leading Navy spectrum sensor development and implementation efforts since the early 1990s. In spectrum classes that NSWC Dahlgren provides to all prospective ship commanding officers, many have inquired as to why

the Navy doesn't have a method to help them enforce their frequency plans and identify interference. They have expressed a sense of helplessness in being able to ensure that their plans are being followed to keep their systems interference-free. To this end, NSWC Dahlgren's Spectrum Engineering Group embarked on an effort to support the development of spectrum monitoring systems for the Navy, with the ultimate goal of providing an automated feedback loop that will alert a Navy frequency manager when its own frequency plan is not being followed or when an unexpected RF emission poses a potential conflict.

THE SPECTRUM MONITORING SOLUTION

Currently, a joint project between the Dahlgren's Spectrum Engineering Group and the commercial firm Argon ST is underway to develop a system called the True RF Environment Extractor, or T-REX for short. T-REX is the first step in the quest toward an automated spectrum monitoring system. T-REX will:

- Continuously scan frequency ranges of interest (currently limited from 0.5 GHz to 18 GHz)
- Identify and log each detected RF emission's characteristics
- Compare each signal's characteristics to an emitter list
- Identify the source if there is a match
- Generate a track for each newly detected emission

Although not yet automated beyond this point, an operator interested in a particular emission could then further analyze it and use the system's spinning direction-finding (DF) antenna to determine a bearing to the source. When multiple systems are operating in proximity, the detected signal can then be triangulated, and the exact location of the source determined. The T-REX operator also has the capability to compare tracks to Automatic Identification System (AIS)-based geolocation data for platforms that are properly equipped. These capabilities, as well as others, are planned for automation in the coming years.

The T-REX system includes a complete complement of equipment to perform RF signal intercept, processing, analysis, classification, and data reporting. The system consists of commercial off-the-shelf (COTS) equipment and runs on Microsoft's Windows XP operating system. It is organized into three functional groups, including the main mission antenna (MMA) assembly (see Figure 1), the remote location equipment (receiver assembly) (see Figure 2), and the operator workstation (see

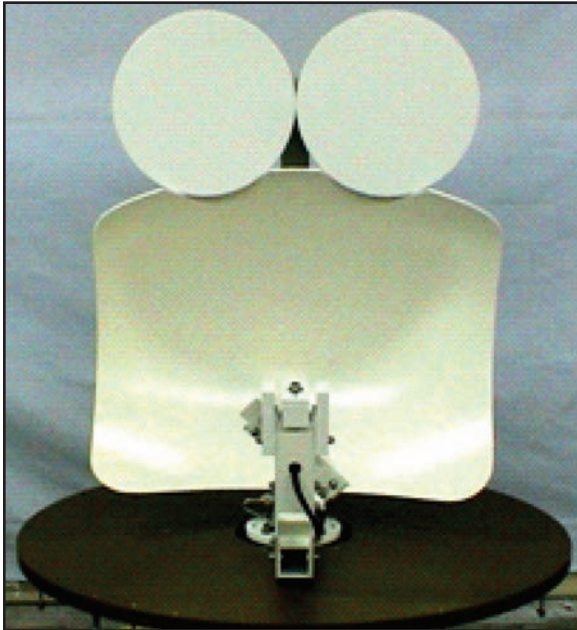

Figure 1. Main Mission Antenna (DF)

Figure 3). These components are connected with other add-on components, such as a Global Positioning System (GPS) time receiver, to complete the T-REX Remote Site System (see Figure 4).

The MMA consists of a 0.5–18 GHz antenna assembly, with both omnidirectional and high-gain spinning DF elements, which are both contained in environmentally protective radomes. In shipboard installations, the MMA would be located topside on the mast or ship superstructure, and for land applications, on a tower or other high point. The remote location equipment consists of an RF distribution component, microwave receiver, coherent signal processor (CSP), digital pulse analyzer (DPA), and an electronic support measures (ESM) processor. This latter subcomponent will need to be located inside a structure within proximity of the antenna. The operator workstation consists of a processor with keyboard, trackball, and dual flat-panel displays. The subsystem provides the user with a user-friendly Microsoft Windows-based software application interface that enables the operator to monitor the full RF bandwidth, build a prioritized scan strategy to maximize probability of intercept for signals of interest, display the detected spectrum, or perform detailed analysis on signals of interest using the digital pulse analyzer. An example screen display is shown in Figure 5.



Figure 2. Remote Location Equipment



Figure 3. Operator Workstation

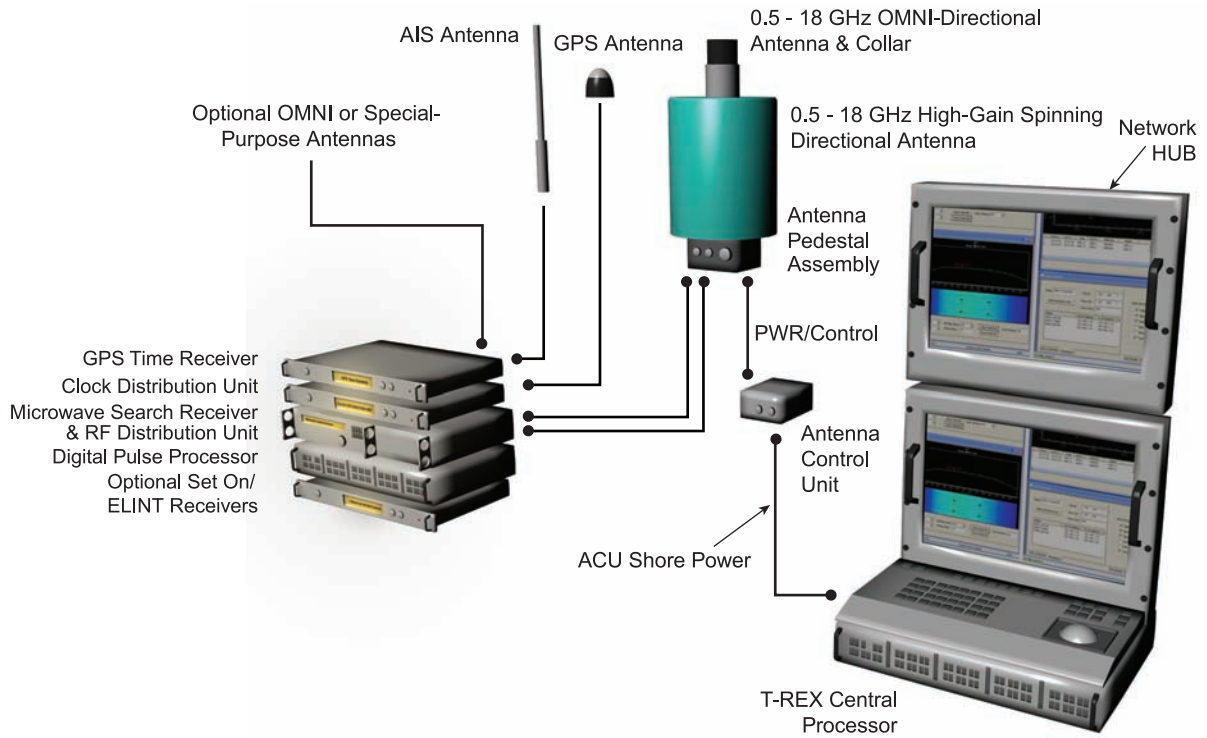

Figure 4. T-REX Remote Site System Components

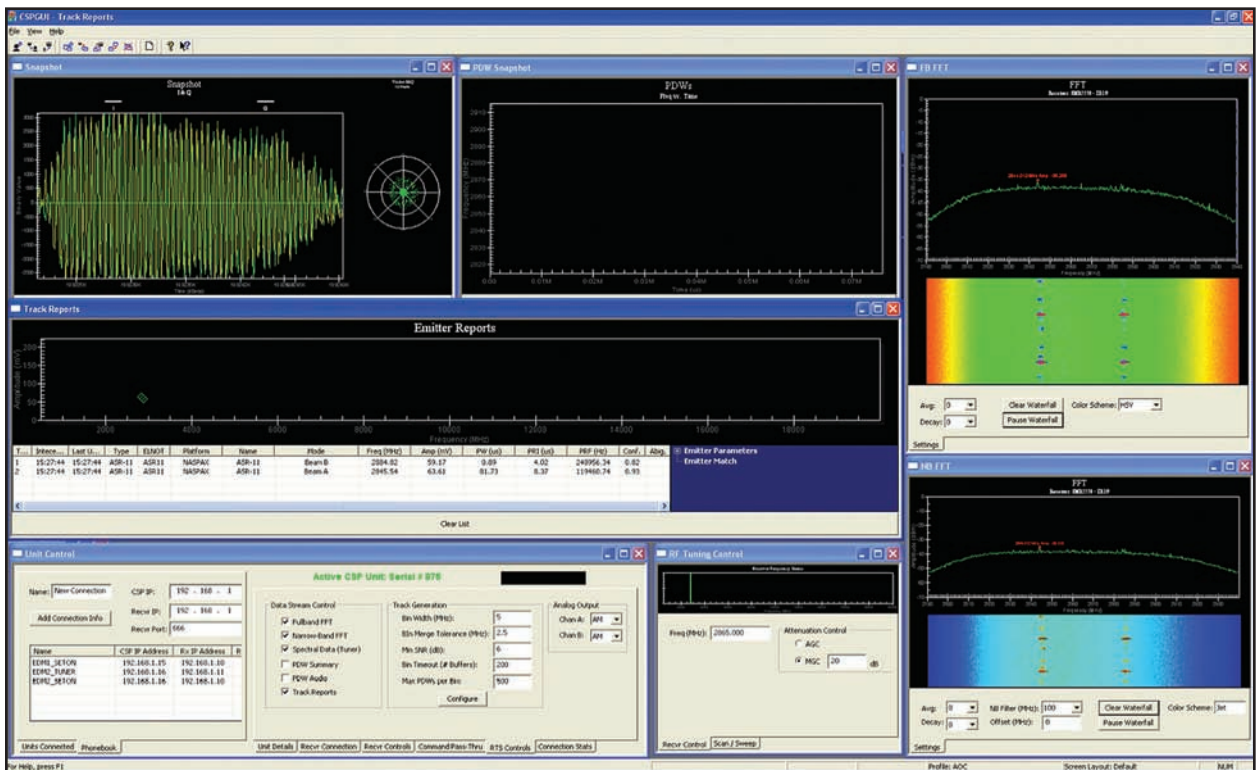

Figure 5. T-REX Operator Workstation Screen Display

Currently, the T-REX system is installed and being evaluated at NSWC Dahlgren. To minimize the time and cost associated with first article testing, the prototype T-REX system will undergo stringent testing to evaluate system performance and determine reliability prior to deploying the system to PMRF. Dahlgren's proximity to active waterways enables testing of all system components in live situations in addition to simulated test cases. The T-REX evaluation should be completed by the second quarter of FY09, with deployment to PMRF immediately following (see Figure 6).

THE PMRF "TESTBED"

A test location for the T-REX system was needed that would allow all of the system components to be utilized and challenged in an active Navy environment. To meet this requirement, the PMRF was chosen to house the initial test deployment of T-REX. Given PMRF's existing interest, infrastructure, and their Navy mission, they exemplify the perfect place to test the first prototype T-REX system.

PMRF is the world's largest instrumented multi-environment range and the only one in the world capable of supporting surface, subsurface, air, and space operations simultaneously. NSWC Dahlgren has been working with PMRF for many years, providing technical expertise concerning their spectrum

needs. PMRF has been proactive in spectrum management and hopes to upgrade its capability in the near term. They expressed a strong interest in an automated spectrum monitoring system and ultimately would like to strategically outfit several Navy sites in the Hawaiian Islands to build a networked "Spectrum Monitoring Grid" that can be operated from a single control point. The goal is to fuse collected data from all the sensors to provide a seamless spectrum picture of the covered region.

The initial installation of the T-REX system will be dual-purpose, with PMRF gaining the benefit of the system in its current configuration to support their range activities, while at the same time providing feedback to NSWC Dahlgren on system performance and suggested improvements. The installation location of the first T-REX system at PMRF will be on a small remote site at the highest point of Niihau, a small, privately owned island approximately 17.5 miles Southwest of Kauai, where the Navy leases a small plot for monitoring antennas. This is across the Kaulakahi Channel from the main PMRF site at Barking Sands on the west coast of Kauai. This location will give the T-REX antenna line-of-site coverage over the entire Kaulakahi Channel, where most of the ship and aircraft testing occurs, as well as north and west of Niihau to cover the flight paths of ballistic missile tests. The antenna

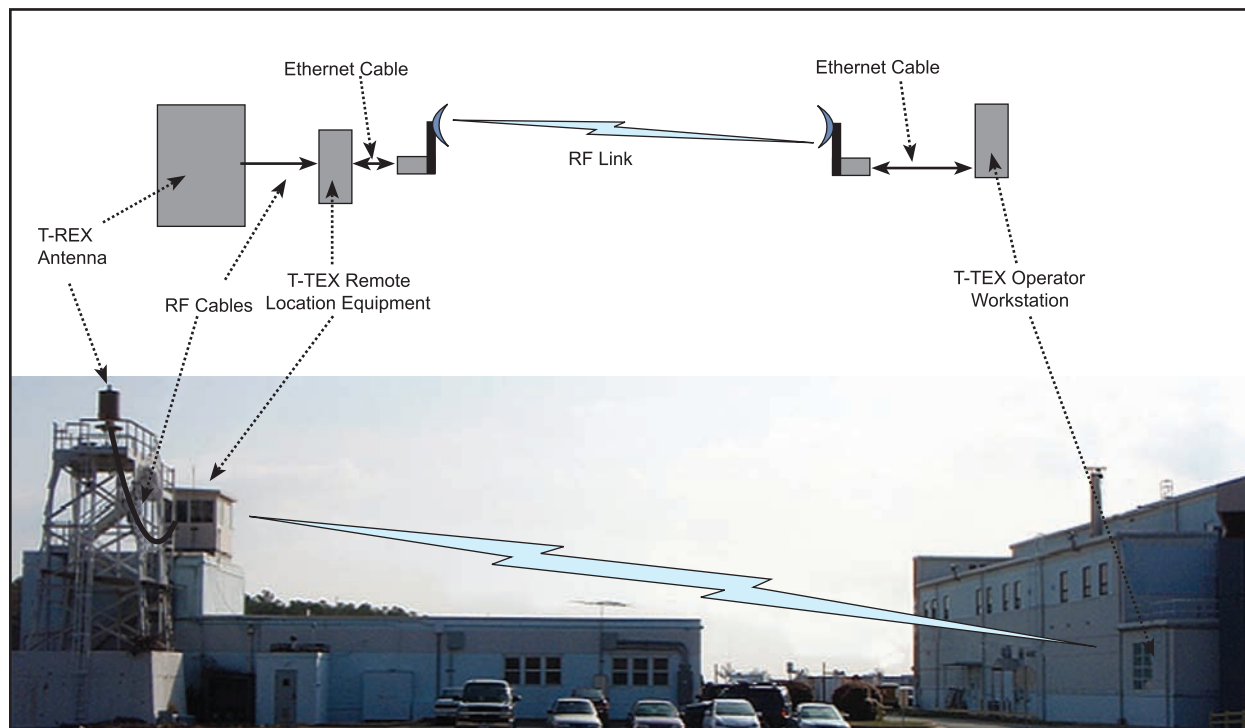

Figure 6. NSWC Dahlgren Evaluation Installation Prior to PMRF Deployment

will be mounted on a tower at the site, with the remote location equipment housed in a small-powered and air-conditioned equipment shelter. The operator workstation will be located at the PMRF frequency manager's control room at Barking Sands (see Figure 7).

The two T-REX equipment racks will be connected through a PMRF intranet local area network (LAN) that utilizes a dedicated microwave link between Kauai and Niihau. Additionally, since the PMRF frequency manager wants to be able to monitor and control the T-REX from multiple locations at PMRF, the requisite software and settings will be installed on several computers on the LAN so that any one of them can take over the role of the operator workstation and monitor and control the T-REX. Whether utilizing the operator workstation or any other properly configured computer, the user will control the T-REX by simply running remote desktop control software called Ultra VNC, taking over control of the processor on the remote location equipment rack that runs the T-REX software. Once the first prototype has been adequately tested and evaluated, with user feedback incorporated into design improvements, NSWC Dahlgren will deploy at least one or two more systems at PMRF to provide the ability for an operator to pinpoint any source or errant emission near their range through triangulation, and eventually, with further development, the full PMRF grid.

At the same time that the system is being evaluated at PMRF, NSWC Dahlgren programmers will be working on linking the T-REX system with the fleet standard AESOP frequency management

software. Using extensible markup language (XML) file protocols, the detected spectrum output of the T-REX will be fed into the AESOP software for comparison to the current area's frequency plan. Automated user warnings will be generated when variations or conflicts are detected between the frequency plan and the T-REX monitored spectrum. PMRF would like to create frequency plans that include all the emitters expected to be active during a test and then receive warnings if and when undesired signals are detected. Once this phase is complete, the Navy will have the first version of a comprehensive, automated frequency management and spectrum monitoring system that will be able to detect and locate spectrum conflicts in real time.

The planned spectrum monitoring grid for PMRF could accomplish all the trademark goals of a modern spectrum monitoring system. Future spirals could include emerging techniques such as highly accurate, multisite geolocation via JASA 2.0-compliant signal time-of-arrival measurements. Other capabilities, such as specific emitter identification and powerful electro-optic infrared (EOIR)-like tracking cameras are also possible upgrades for the system. The plan has a number of remaining hurdles and will require buy-in from key NAVAIR and NAVSEA stakeholders to move forward. If the T-REX system meets expectations and further development is supported, the Navy will benefit tremendously from this capability.

REFERENCE

1. SECNAV Instruction 2400.1, *Electromagnetic Spectrum Policy and Management*.

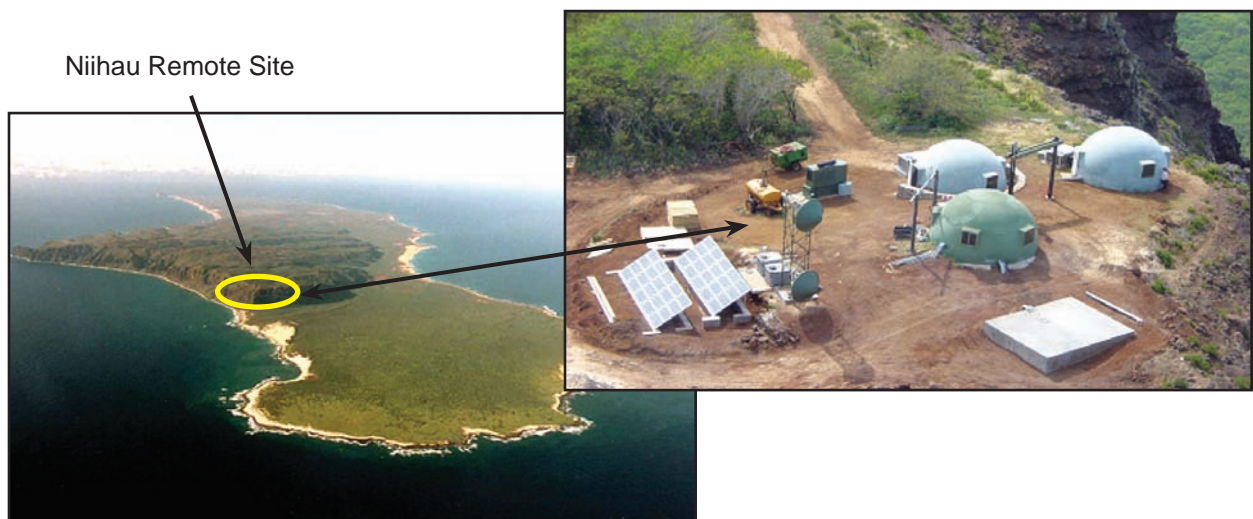

Figure 7. Niihau Remote Site Location for First T-REX Installation at PMRF

NSWC DAHLGREN'S ROLE IN THE NAVY'S SPECTRUM CERTIFICATION PROCESS

By John Darden





Imagine an aircraft carrier in the midst of retrieving and launching aircraft engaged in combat operations. The electromagnetic environment generates wandering electrical currents that ignite a rocket aboard an aircraft. The wayward rocket slams into another aircraft causing a fuel spill. The fuel ignites, and the resulting fire and exploding ordnance kill more than 130 personnel, injure many others, and destroy 26 aircraft (see Figure 1).

The incident just described actually happened. It occurred because the electromagnetic environment at the time was not given high priority. Fortunately, incidents such as this are far less likely to happen today due to the critical role that the Naval Surface Warfare Center (NSWC) Dahlgren Division plays in the Navy's spectrum certification process. NSWC Dahlgren has been at the forefront of investigating, analyzing, and implementing solutions concerning electromagnetic environmental problems since 1956.¹ Today, Dahlgren personnel perform testing and measurements of equipment and systems that utilize the electromagnetic spectrum both on-site and in the field. Using state-of-the-art test equipment and innovative testing techniques, scientists and engineers are able to provide detailed analyses of spectrum-dependent equipment and systems without impinging on equipment or system integrity or capability.

As a Naval Sea Systems Command (NAVSEA) Warfare Center activity, NSWC Dahlgren, through its Electromagnetic and Sensor Systems Department, E3 Force Level Interoperability Branch, Spectrum Engineering Group, provides support to developers and procuring agencies in obtaining frequency allocations for their equipment or systems. The branch works closely with project personnel, program office personnel, and vendors, together with unclassified and classified resources, to conduct research on the equipment or system requiring spectrum certification.

In compliance with National Telecommunications and Information Administration (NTIA) regulations and Department of Defense directives, the U.S. Navy implemented a policy regarding Electromagnetic Environmental Effects (E3) and Spectrum Supportability to manage the effects the electromagnetic environment has on operational equipment, systems, platforms, and forces. Spectrum supportability is defined as: "the assessment as to whether the electromagnetic spectrum necessary to support the operation of a spectrum-dependent equipment or system during its expected life cycle is, or will be available."² Accordingly, a spectrum supportability determination is mandated for all equipment and systems that utilize the

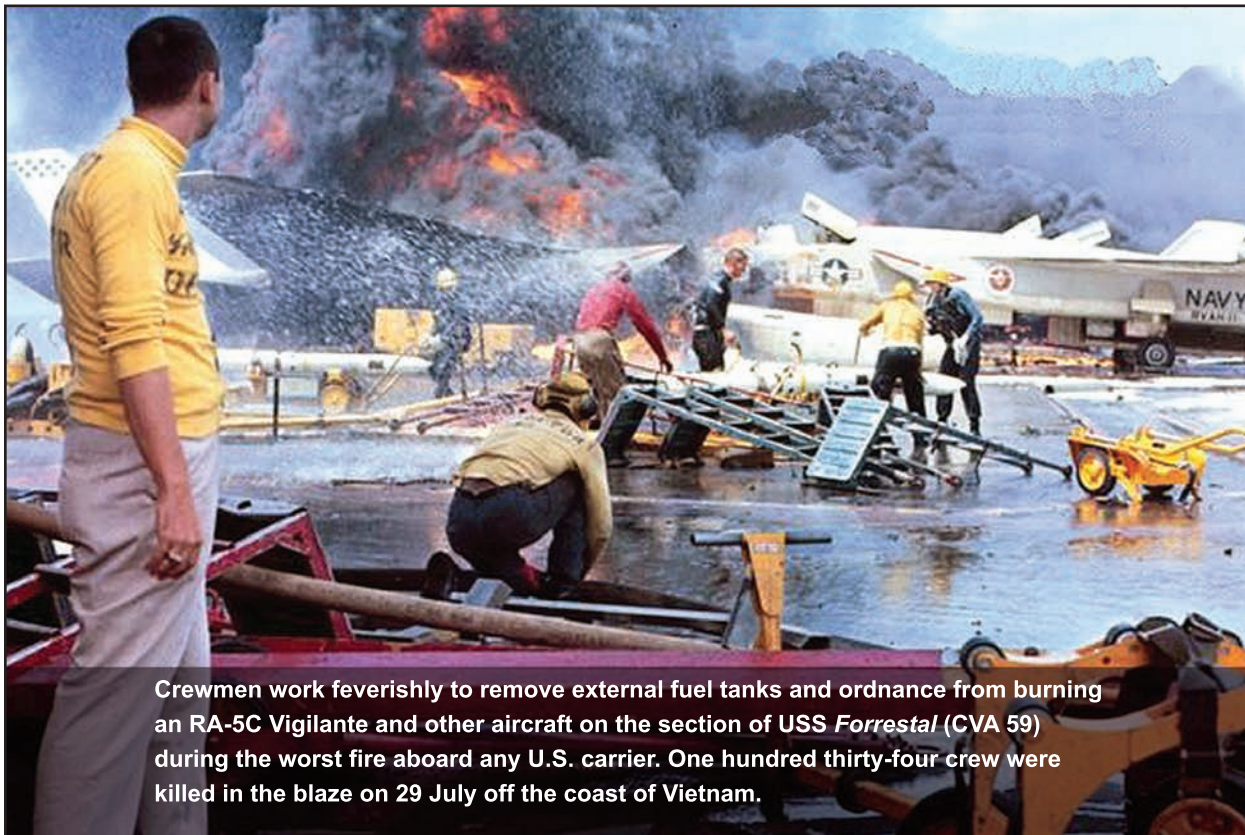

Crewmen work feverishly to remove external fuel tanks and ordnance from burning an RA-5C Vigilante and other aircraft on the section of USS *Forrestal* (CVA 59) during the worst fire aboard any U.S. carrier. One hundred thirty-four crew were killed in the blaze on 29 July off the coast of Vietnam.

Figure 1. Fire Due to a Runaway Rocket On Board the Flight Deck of USS *Forrestal*, July 1967

electromagnetic spectrum before proceeding into system development and demonstration (SDD) or production and deployment (P&D) phases of the acquisition process, unless specific authorizations or waivers are granted.

Equipment spectrum certification, alternately called spectrum certification, is defined as: “the statement(s) of adequacy received from authorities of sovereign nations after their review of the technical characteristics of a spectrum-dependent equipment or system regarding compliance with their national spectrum management policy, allocations, regulations, and technical standards.” Spectrum certification is a subprocess in the spectrum supportability process. This process, also known as the J/F-12 process, begins by completing and submitting DD Form 1494, “Application for Equipment Frequency Allocation” (see Figure 2). After a sequence of steps that include multiple reviews, possible correction or revision, and approval of the application, a spectrum certification is granted, and a J/F-12 number is issued for the equipment or system.

If the data needed to complete a DD 1494 application is not available—as is often the case for commercial off-the-shelf (COTS) or foreign equipment—then the E3 Force Level Interoperability Branch performs measurements and tests as needed on the spectrum-dependent equipment. Members of the Spectrum Engineering Group conduct analyses on the measured data and provide test reports to document test procedures and techniques, data collected, and the underlying reasoning. Finally, the branch completes the application with the required data, whether measured or calculated, writes the cover letter and the foreign coordination letter if necessary, and submits the documents to the developing or procuring office.

Spectrum supportability of radio-frequency sensors in an environment that is shared with other sensors, communication devices, electronic warfare equipment, and a multitude of other spectrum-dependent devices falls under the purview of the Electromagnetic and Sensor Systems Department. This concentration led the department to establish a capability to support the spectrum certification

APPLICATION FOR EQUIPMENT FREQUENCY ALLOCATION	CLASSIFICATION	DATE	<i>Form Approved OMB No. 0704-0188</i>
			PAGE 1 OF PAGES
<small>The public reporting burden for this collection of information is estimated to average 24 hours per response, including the time for reviewing instructions, searching existing data sources, gathering and maintaining the data needed, and completing and reviewing the collection of information. Send comments regarding this burden estimate or any other aspect of this collection of information, including suggestions for reducing the burden, to the Department of Defense, Executive Services Directorate (3704-0188). Respondents should be aware that notwithstanding any other provision of law, no person shall be subject to any penalty for failing to comply with a collection of information if it does not display a currently valid OMB control number. PLEASE DO NOT RETURN YOUR FORM TO THE ABOVE ORGANIZATION. RETURN COMPLETED FORM TO THE USING AGENCY OR CONTRACTING AGENCY, AS APPROPRIATE.</small>			
DOD GENERAL INFORMATION			
TO		FROM	
1. APPLICATION TITLE			
2. SYSTEM NOMENCLATURE			
3. STAGE OF ALLOCATION (<i>X one</i>)			
<input type="checkbox"/> a. STAGE 1 - CONCEPTUAL <input type="checkbox"/> b. STAGE 2 - EXPERIMENTAL <input type="checkbox"/> c. STAGE 3 - DEVELOPMENTAL <input type="checkbox"/> d. STAGE 4 - OPERATIONAL			
4. FREQUENCY REQUIREMENTS			
a. FREQUENCY(IES)			
b. EMISSION DESIGNATOR(S)			
5. TARGET STARTING DATE FOR SUBSEQUENT STAGES			
a. STAGE 2		b. STAGE 3	c. STAGE 4
6. EXTENT OF USE			
7. GEOGRAPHICAL AREA FOR			
a. STAGE 2			
b. STAGE 3			
c. STAGE 4			
8. NUMBER OF UNITS			
a. STAGE 2		b. STAGE 3	c. STAGE 4
9. NUMBER OF UNITS OPERATING SIMULTANEOUSLY IN THE SAME ENVIRONMENT			
10. OTHER J/F 12 APPLICATION NUMBER(S) TO BE		11. IS THERE ANY OPERATIONAL REQUIREMENT AS DESCRIBED IN THE INSTRUCTIONS FOR PARAGRAPH 11?	
<input type="checkbox"/> a. SUPERSEDED J/F 12/ <input type="checkbox"/> b. RELATED J/F 12/		<input type="checkbox"/> a. YES <input type="checkbox"/> b. NO <input type="checkbox"/> c. N/Avail	
12. NAMES AND TELEPHONE NUMBERS			
a. PROGRAM MANAGER		(1) COMMERCIAL	(2) AUTOVON
b. PROJECT ENGINEER		(1) COMMERCIAL	(2) AUTOVON
13. REMARKS			
DOWNGRADING INSTRUCTIONS		CLASSIFICATION	

DD FORM 1494, AUG 96

PREVIOUS EDITION MAY BE USED.

Adobe Professional 7.0

Figure 2. DoD General Information Page from DD Form 1494 "Application for Equipment Frequency Allocation"

process. The necessity for spectrum certification is manifold. Navy policy requires that spectrum certification be obtained as one of the requirements for spectrum supportability.³ With the J/F-12 certification of equipment and systems, the data within the application documents provides the capability to evaluate equipment or system compliance with spectrum management policies, and national and international frequency allocations, regulations, and technical standards. Additionally, certification is required throughout the acquisition process as one of the requirements to achieve approval to transition to the next phase. Spectrum certification is also required for the procurement of nondevelopmental items (NDI) and commercial items such as COTS equipment or systems including Federal Communications Commission (FCC) Part 15 (low-power, unlicensed) devices. If the device requiring electromagnetic spectrum is to be used in a foreign country, then the required certification must be modified in order to obtain a Host Nation

Frequency Authorization for foreign government authorization to operate the equipment within its jurisdiction. Recertification for equipment and systems previously certified must be performed when new frequency assignments are sought, modifications to radiation emissions are made, modes of operation are changed, locations of operation are changed, and so forth. Finally, a Stage 1 certification is required to obligate funds beyond the concept refinement stage to further research, develop, procure, or operate the equipment or system in question. Figure 3 shows a Dahlgren employee adjusting a spectrum analyzer.

An example of NSWC Dahlgren's role in the spectrum certification process was evident in the recent work performed in support of the Shipboard Warehouse Management System Local Area Network (SWMS LAN) aboard the dry cargo/ammunition ship USNS *Lewis and Clark* (see Figure 4). The LAN was to be used as a means of inventory control aboard the ship. The LAN was to be



Figure 3. An NSWC Dahlgren employee adjusts a spectrum analyzer—a tool used to perform a typical spectrum certification measurement.



Figure 4. NSWC Dahlgren performed measurements of the LAN aboard the dry cargo/ammunition ship USNS *Lewis and Clark*

implemented using multiple computers with wireless access, handheld scanners, and Wi-Fi access points. Spectrum certification of the system was mandatory due to the potential hazard of radiant electromagnetic energy in an enclosed environment with ordnance. The Spectrum Engineering Group performed measurements on the access points, tabulated acquired data, and wrote technical reports describing the test methodology and presenting the measured data necessary for a DD 1494 application. Work performed concurrently in other branches verified that the power levels due to the LAN and its other components met the standards for safe operation in close proximity to ordnance.

The goal of obtaining a spectrum certification can be a protracted process. The certification process should be initiated as early as possible in compliance with the requirements imposed for attaining milestones in the acquisition process. A

partial list of the equipment requiring spectrum certification is as follows:

- Communications equipment
- Radars
- Transmitters
- Receivers
- Electronic Warfare (EW) systems
- Simulators
- Previously certified equipment that has been modified
- Test equipment
- Existing systems lacking certification
- COTS items
- Equipment purchased from foreign nations
- Global Positioning System (GPS) equipment

Items not requiring certification include electro-optics devices, nontactical and intrabase radios, and fuze development.

Successfully navigating through the process and obtaining J/F-12 certification ensures that the equipment, when granted an authorized frequency assignment, can be legally operated in the geographical location in which it is situated. Through this process, NSWC Dahlgren supports the overarching spectrum supportability process and ensures that scarce electromagnetic spectrum is available when the warfighter needs it, thus potentially saving lives, protecting materiel, and helping to ensure mission success.

REFERENCES

1. James P. Rife and Rodney P. Carlisle; *The Sound of Freedom: Naval Weapons Technology at Dahlgren, Virginia, 1918–2006*; U.S. Government Printing Office; NSWCDD/MP-06/46; p. 103.
2. OPNAVINST 2400.20E, Enclosure (1), dated 19 July 2007.
3. Ibid.

SHIPBOARD ELECTROMAGNETIC INTERFERENCE PROBLEM SOLVING

By Bradley Conner and Richard Soares

INTRODUCTION

Electromagnetic Interference (EMI) problem solvers from the Naval Surface Warfare Center, Dahlgren Division (NSWCDD) Electromagnetic Environmental Effects (E3) Force Level Interoperability Branch support the Naval Sea Systems Command (NAVSEA) E3 Technical Warrant Holder under the Shipboard Electromagnetic Compatibility Program (SEMCIP). With many high-power transmitters and sensitive electronic equipment collocated aboard naval vessels, electromagnetic compatibility (EMC) is an important role and responsibility of government engineers. Uncorrected EMI problems can severely degrade warfighting capabilities. EMI problem solvers are EMC engineers who provide initial response to urgent fleet requests for EMC assistance, perform characterization and quantification of EMI problems, identify solutions to mitigate EMI problems, and then evaluate their effectiveness. SEMCIP is the “honest broker” for the U.S. Navy by determining whether an EMI solution should best be installed on the source or victim system. EMI problem solvers must work closely with sailors and operating forces at the waterfront, program managers and in-service engineering agents (ISEAs) at the different warfare centers, and technology experts in industry. This article describes the steps necessary to solve shipboard EMI problems and highlights some of the success stories from current problem-solving efforts.

BACKGROUND

NSWCDD E3 Division strives to be the defense community’s leader for ensuring mission success in the operational electromagnetic environment. One of the core competencies is EMI problem solving. There are inevitably EMI problems among the many high-power transmitters, sensitive receivers, and various other electronic equipment collocated in close proximity aboard naval vessels. Unlike shore-based facilities, there is usually not enough real estate on ships to move systems to noninterfering locations (see Figure 1). EMI problem solvers must step in and find solutions quickly and effectively, quite often without much advance warning.

Shipboard EMI is not a new problem. Out-of-band and other unintentional emissions degrade the function and operation of other onboard systems. Initially, EMI was caused by a lack of common knowledge concerning radio frequency (RF) characteristics by those who installed radios on ships and by those who operated them. As more and more transmitters and receivers were installed on ships, the EMI problems became more frequent, severe, and difficult to solve. In the 1970s, NAVSEA started a program called SEMCIP to manage these problems. SEMCIP continues to provide the U.S. Navy with prevention, identification, characterization, quantification, and correction of shipboard EMI problems affecting weapons systems, radars, communication links, and other electronic systems.



PROBLEM INVESTIGATION

SEMCIP desires to find and correct problems before the fleet experiences them. There is a great deal of analysis that happens upfront in an electronic system’s life to make sure the equipment will be electromagnetically compatible with other systems. It is much easier to implement fixes during system design than to do so after they are already fielded.

Even with upfront engineering, unpredicted EMI problems are bound to occur. EMI problem solvers have a role in both EMC certification and “Big Bang” testing to reduce the risk of mission degrading EMI to the fleet. During a ship’s EMC certification, various EMI recognition tests and system-to-system interoperability tests are performed to determine the current EMC posture of a deploying ship. During Big Bang, each electronic system aboard the ship is monitored by an EMC engineer while systems are turned on sequentially from highest frequency to lowest frequency. Most of the EMI problems solved to date have been discovered during an EMC certification or Big Bang.

Certainly, not every maritime scenario and equipment configuration can be evaluated during the EMC certification or Big Bang. Initial indications of EMI—such as strobes on a radar display or an unusually high bit-error rate on a communication system—are investigated by ship personnel. When a problem cannot be easily resolved, the fleet contacts EMI problem solvers from SEMCIP to address and resolve the issue. SEMCIP has the surface Navy’s top echelon of technical expertise in resolving EMI problems.

When SEMCIP is contacted to solve a shipboard EMI problem, a team of engineers will travel to the ship, sometimes in port and sometimes at sea, to perform testing and investigate the problem in detail (see Figure 2). Standard equipment includes a spectrum analyzer, oscilloscope, test antenna, directional couplers, current probes, and assorted cables and connectors. Spectrum characteristics, such as frequency and power level, must be ascertained in order to identify possible EMI source(s). Spectrums are observed



Figure 1. Like USS *Dwight D. Eisenhower* (pictured here), most ships have limited real-estate for topside electronic equipment.

at various places in the receive path of a system to determine where the problem actually occurs: sometimes at the output of a directional coupler of a transmitter, sometimes from an intermediate frequency test point, sometimes using a magnetic field clamp, and sometimes above deck using a directional test antenna. If EMI is continuous wave (CW), then that would indicate a communication system as the culprit; if EMI is pulsed, then that would indicate a radar system. Other key indicators to the EMI problem solver are the pulse repetition frequency, any potential pulse stretching, nonlinearities and intermodulation, or unusually high noise levels.



Figure 2. Two EMC Engineers Analyze Spectrum Characteristics to Solve an EMI Problem

The victim system can also provide valuable information in the search for the EMI source. System faults can indicate and isolate the problem to specific functions or locations in the system. Other system indications, such as number of uncorrected and corrected errors, could assist an EMI problem solver in determining the type of interference present, such as whether there are random or burst errors.

Turning potential systems on and off to see if the problem goes away is probably the most effective way to identify a problem; however, this is usually the last step, because turning off systems adversely impacts the ship operation. Usually, test windows must be coordinated with ship personnel so that critical systems can be turned off safely without impacting current operations. Radar and communication systems on board ships have specific functions that are required for specific ship operation. For example, when aircraft are landing on a carrier, any equipment relating to avionics must be fully operational. Proper coordination is essential for EMI problem investigation on ships.

ANALYSIS AND RESOLUTION

Once an EMI source is identified, key information that characterizes the problem can be used to determine a suitable fix. Extensive analysis must be done to pinpoint the exact cause of the EMI

problem. Some of the questions that need to be answered are:

- What frequencies are causing the interference?
- Under what weather conditions does the EMI occur?
- Does EMI only occur at certain times or at certain pointing angles of the victim antenna?
- Does the interference happen only at night or in certain geographical locations?
- How degrading is the interference?
- What impact does the EMI have on the operational capability of the ship?
- Is the interference on board or from a nearby ship?

These and many other questions must be addressed to determine the best method to mitigate the problem. Problem solvers also assess whether the problem should be corrected at the EMI source equipment or at the EMI victim.

Problem mitigation has varying degrees of complexity. Sometimes there is a simple course of action that can alleviate the problem, such as using another radar waveform, changing coding rates, using more or less signal power, or changing some other setting on the source or victim system. Moreover, sometimes the source system has a faulty component or is operating out of its

intended or assigned frequency range. A simple replacement of a component could fix the problem.

Other examples of fixes commonly used to correct EMI problems are metallic tape, radar-absorbing material (RAM), filters, and frequency management. Metallic tape wrapped around components or cables provides additional shielding and creates a solid ground to prevent case-cable penetration (see Figure 3). Although metallic tape is relatively inexpensive and easy to install, it is preferably used as a temporary fix until a more permanent solution is designed and implemented. It is the “duct tape” of the EMI world.

RAM is also a useful tool for EMI control. RAM is often attached to barriers placed between the EMI source and victim to increase isolation and reduce the coupling of electromagnetic energy. RAM is also used on superstructures to prevent reflections. Shipboard signals often reflect off solid

metallic structures, such as the ship’s mast and superstructure. These reflections can couple into other radar and communication antennas or penetrate through cables and other components.

Perhaps the most commonly used form of EMI mitigation is a type of filter (see Figure 4).

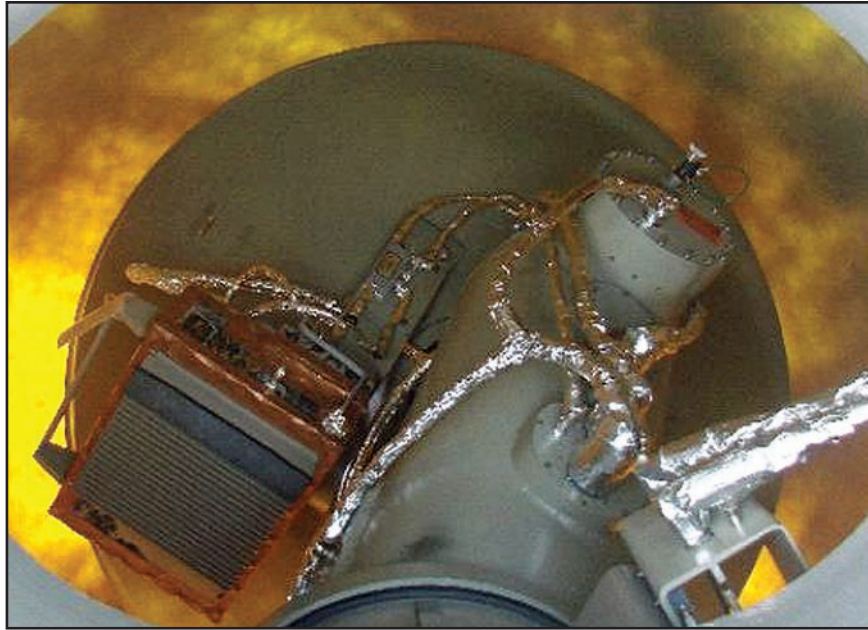

Figure 3. Initial Attempts to Shield Components in the Radome of a Communications System

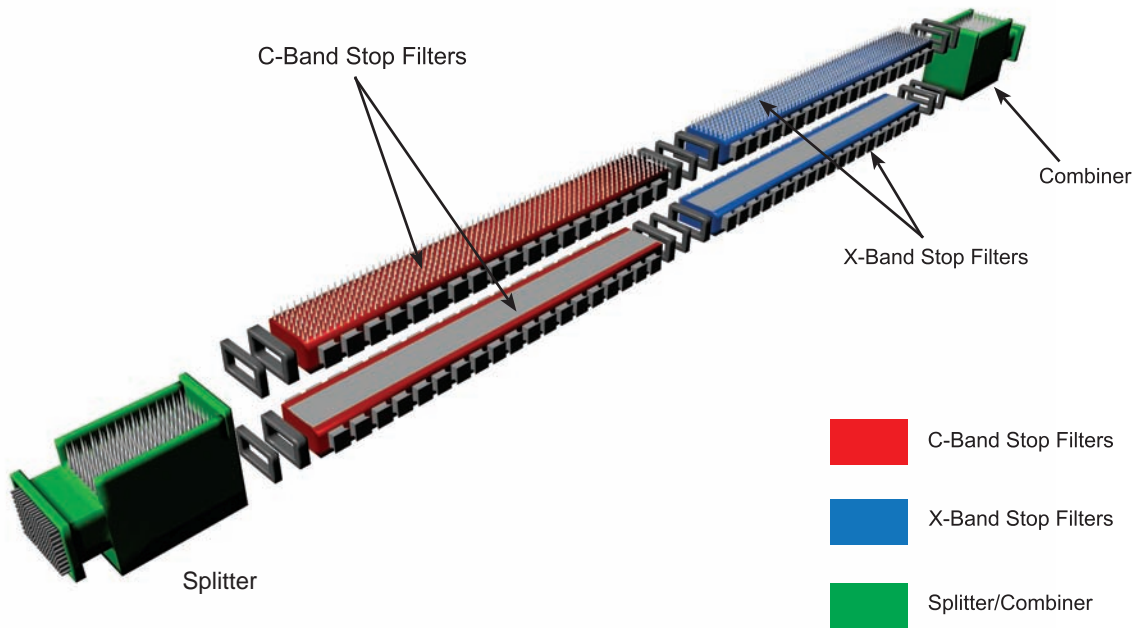

Figure 4. Diagram of the AN/SPS-48 Transmit Waveguide Filter

EMI filters can be used on power lines, in the transmit path, or in the receive path. EMI problem solvers assess whether the best implementation is band-pass, band-reject, or another alternative. Off-the-shelf filters are preferred due to low cost and availability. Many times a new filter must be designed to fulfill the frequency, attenuation, and insertion loss requirements. Prototype filter delivery can take many months, causing substantial delays in implementation and testing. The EMI problem solver must evaluate the trade-offs in system performance when selecting filters and other microwave components.

Frequency management is a very useful method to fix EMI problems. By avoiding certain frequencies or channels, an EMI source can prevent EMI to a victim system. Similarly, a victim can be restricted to certain frequencies or channels to avoid being interfered with. Frequency management is sometimes not the preferred solution because it can limit a system's capability to function as intended.

NECESSARY WORKING RELATIONSHIPS

EMI problem solvers must interface with many organizations both internal and external to the U.S. Navy. Government program managers provide leadership and life-cycle support for various programs in the Navy. Industry develops and builds the hardware and software required for the warfighter to achieve military objectives. Filter and microwave component manufacturers provide important tools necessary to mitigate EMI. Various ISEAs provide logistical and engineering support to the fleet on a specific system. Sailors and fleet commanders report EMI problems, report operational limitations resulting from EMI problems, and help coordinate ship visits to resolve the problems. EMI problem solvers must be capable of working with all these organizations and maintain a good working relationship with them in order to effectively identify problems and implement

solutions. The most effective method to solve challenging EMI problems is to have a team of subject-matter experts, including EMC engineers and problems solvers (see Figure 5), systems engineers from the U.S. Navy's ISEAs, and sailors who operate and maintain systems on a daily basis. These relationships are critical to both the upfront engineering EMC analysis, as well as the urgent problem solving for deployed forces.

CONCLUSIONS

There is no standardized procedure available to identify EMI problems, because there are no standard EMI problems. Each problem is unique with different characteristics and level of complexity. That is why electrical engineers are required to identify, investigate, and characterize EMI and then provide practical EMI fixes. It takes an engineering mindset to analyze and determine the best way to solve and fix problems. Additionally, there is no standard method of EMI problem solving that a handbook could address. The EMI/EMC area is continually affected by new challenges due to the variety and evolving complexity of electronic systems being installed on ships.

Many electrical engineers developing military systems are unaware of the challenges present in the electromagnetic environment and do not recognize the importance of EMC. It is up to EMI problem solvers to ensure that new systems installed on ships are successfully integrated with existing electronic equipment. Many challenges lie ahead for the U.S. Navy's EMI problem solvers, but many of these engineers are eager for the challenge and are willing to do whatever it takes to assist the warfighter in defending our country and the freedoms we enjoy.



Figure 5. EMI Problem Solvers Troubleshoot a Navigation Radar

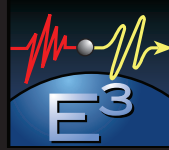

THE AN/SPS-67 WAVEGUIDE FILTER

By Rick Gustavus

THE SPURIOUS NOISE PROBLEM

The AN/SPS-67 radar is used as navigation radar on many Navy ships. This particular antenna configuration radiates or transmits frequencies that are generated within the AN/SPS-67 radar systems magnetron. Some of the frequencies generated are outside of the fundamental or main frequency of the AN/SPS-67 radar system, but they are also transmitted and are known as spurious noise. Spurious noise can get into one of the nearby satellite communications (SATCOM) systems and cause it to lose lock on a satellite that is in orbit over the Earth. This loss of lock on the satellite could be likened to when you are listening to your car radio, and just about the time you hear the most important part of what you're listening to, everything goes to static. Likewise, there are certain sections of the frequency band of the SATCOM system where this spurious noise may occur at a critical moment of a conflict. When it does, the SATCOM communications link would be lost, which could impact mission success. A depiction of the AN/SPS-67 radar system is shown in Figure 1.

THE PURSUIT OF A SPURIOUS NOISE SOLUTION

To deal with spurious noise, a temporary filter was initially developed that employed a sulfur hexafluoride (SF6) gas as an insulator gas to prevent arcing within the filter that could occur due to the AN/SPS-67 radar system's high-power interacting (arcing) within the internal design features of the filter. The storage of the gas cylinders, the leakage of the gas, and many other idiosyncrasies made the design less than optimal; however, it was the only available technology at the time to correct this problem. An SF6 filter is shown in Figure 2.

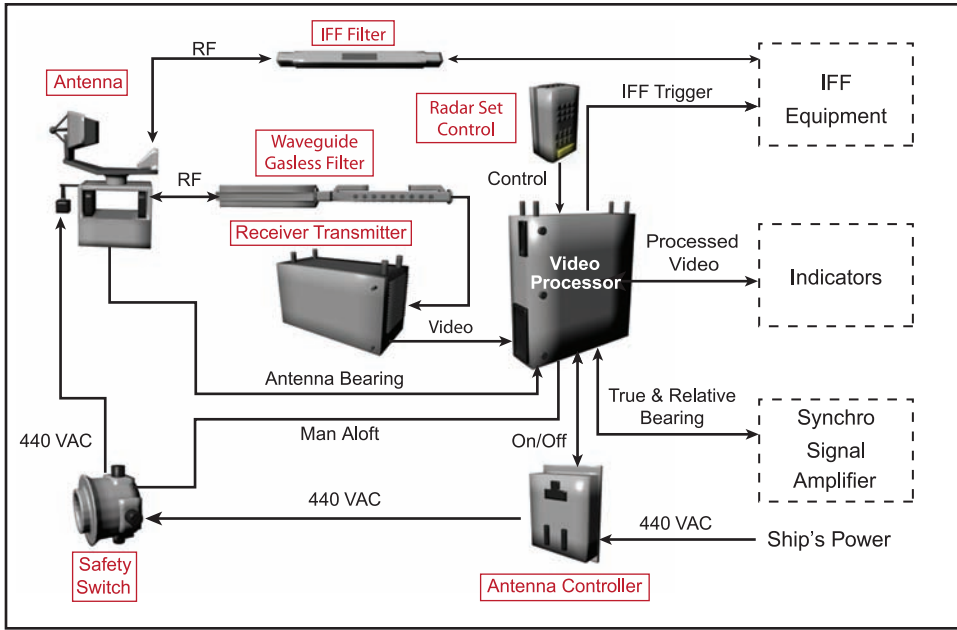

Figure 1. The AN/SPS-67 Radar System

Gas usage and storage, as well as the added maintenance costs associated with using SF6 were among many leading concerns preventing any immediate fleetwide installation of this filter. Consequently, a continued search for a filter design with a mature technology that did not require any insulating gas was found in work coming out of the Doppler weather radar field. This filter consisted of two types of filters (a 3-dB hybrid and an ab-

sorptive section of the filter had a unique characteristic that literally “absorbed” all spurious noise frequencies remaining above the fundamental frequency and, in doing so, would not allow those spurious noise frequencies to pass up to the AN/SPS-67 radar antenna.

Without the filter, the spurious noise would be passed up to the antenna, amplified by the gain of the antenna, and then transmitted into the surrounding atmosphere, where interference with the SAT-COM system could cause mission degradation and loss of mission capability. Because the filter is bidirectional, it can be installed in either direction. But for the purpose of the illustration shown in Figure 3, the power is first shown entering the 3-dB hybrid section of the filter. The power is then split or divided and then



Figure 2. Sulfur Hexafluoride (SF6) Gas-Filled Filter Installed Aboard USS Tarawa

sorptive section) that were combined to perform the function required to satisfy the pass-band requirements needed to eliminate the spurious noise of the AN/SPS-67 radar system. The overall filter basically created a sandbox for the AN/SPS-67 radar system to play in without impacting any other system around it. The filter used a 3-dB hybrid pass-band filter that provided rejection at the lower skirt (or lower range of the AN/SPS-67 radars frequency band, and part of the rejection at the upper skirt, or upper range of the AN/SPS-67 radars frequency

recombined as it leaves this filter section that allows the elimination of any insulating gas because, simply speaking, the power has been cut in half. The connection from the magnetron to the antenna of the AN/SPS-67 radar system through which the transmitter signal power travels up to the antenna is called *waveguide*, and it looks like rectangular tubing. This rectangular tubing is specifically sized for the frequency of the AN/SPS-67 radar system. The various spurious noise frequencies that originate from the AN/SPS-67 magnetron travel along

band), while the absorptive section of the filter then took over and provided all of the rejection at the upper skirt.

In looking more closely at the 3-dB hybrid section of the filter, we gained the advantage of eliminating any insulating gas, as this portion of the filter splits or divides the power coming from the AN/SPS-67 radar (magnetron) and then recombines it again at the output of this filter section. The

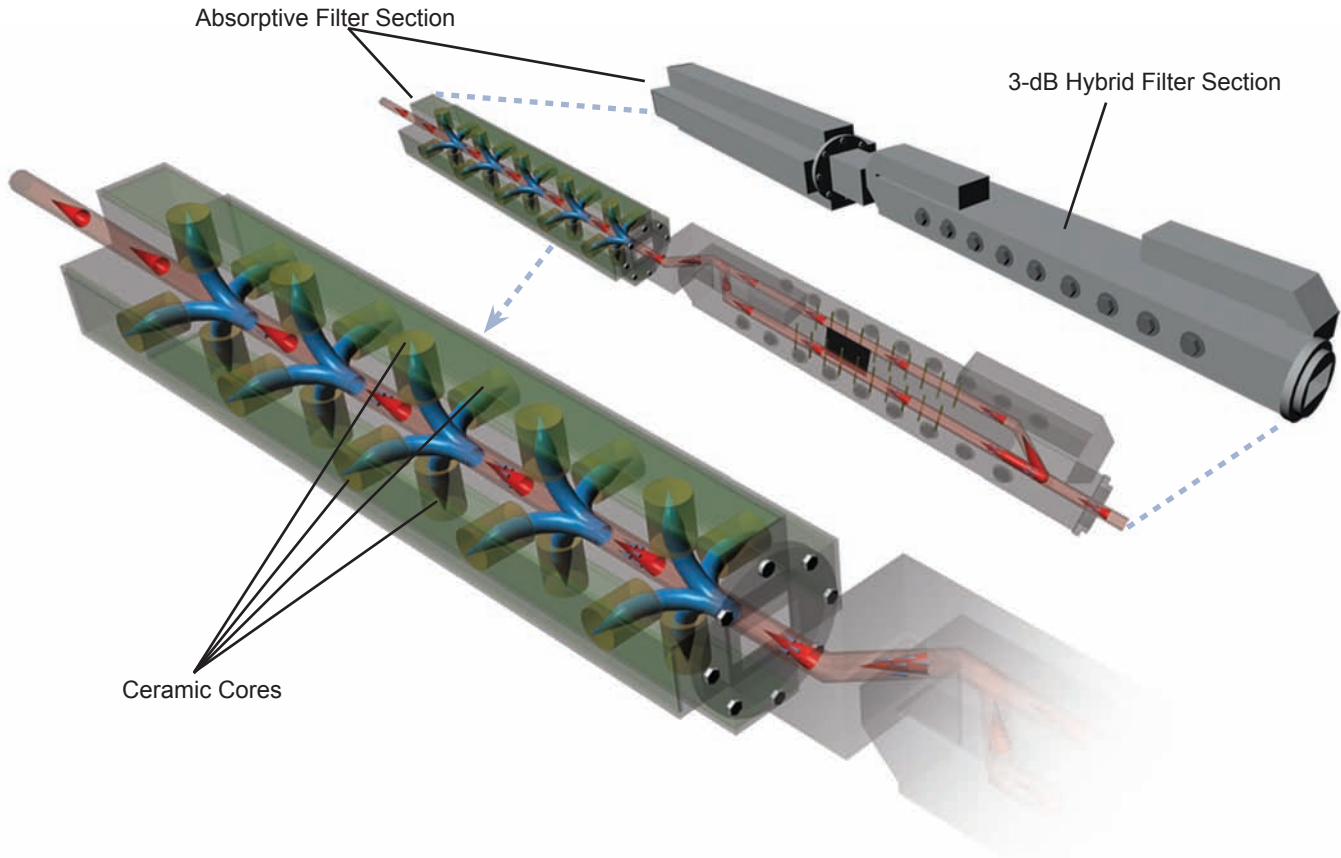

Figure 3. AN/SPS-67 Waveguide Gasless Filter

either the wide wall or the short wall of the waveguide and as indicated by the arrows in Figure 3. The effect of any frequency (indicated in blue)—other than the fundamental frequency (indicated in red)—is absorbed into the respective ceramic rods. These ceramic rods are doped to a certain capacitive characteristic, are sized to a specific diameter, and are then built into the walls of the absorptive filter. One must consider that any impact to the design of the filter must be done without affecting the performance of the AN/SPS-67 radar system. One of the biggest challenges was testing the filter for the ability to meet this very important performance capability for all the infinite possible frequencies.

TESTING OF THE FILTER

Testing of the filter was accomplished with the submission of two filters in four phases of testing: harmonic frequency rejection testing; laboratory testing; land-based testing; and power testing. Harmonic frequency rejection testing was one of the critical performance characteristics of the waveguide filter. The filter's ability to deal with all of the harmonics/frequencies above the TE101 mode

generated by the AN/SPS-67 radar systems magnetron and then transmitted by the (V)1 antenna was critical. The elimination of these harmonics/frequencies was of primary concern because of the impact to the AN/WSC-6 SATCOM system and other collocated systems. Harmonic/frequency testing could be accomplished only by subjecting the filter to an environment of infinite frequencies and then measuring the resultant spectrum at the output of the filter.

Testing involved creating two chambers, one on each side of the filter, and injecting all frequencies below and above the frequency range of the filter into one of the chambers. The frequencies or output were measured in the other chamber and determined the dynamic performance properties of the filter. The testing concluded that the waveguide filter successfully rejected all harmonics/frequencies above the TE101 mode in the frequency range of 7 to 12.8 GHz.

Laboratory testing was conducted in the NSWC Dahlgren, E3 Force Level Interoperability Laboratory and was done to evaluate the filter's frequency response and insertion loss performance. This testing would more closely determine

the frequency range at which the waveguide filters began to pass certain frequencies, as well as specifically define the cut-off frequencies of the filters. A critical change had been made to the pass-band frequency specification. Therefore, it was necessary to make a determination of compatibility with the AN/SPS-67 radar system pulse widths and ensure that there would not be cause for concern of a decrease in power output to the radar system by the filter. Subsequent testing with the band-pass filters installed in an AN/SPS-67 radar system at Dam Neck, Virginia, using targets of opportunity, confirmed that the filters did not degrade target detection.

Land-based test events employed an actual operating AN/SPS-67 radar system to verify the effectiveness and performance of the filter design. The AN/SPS-67 radar system was operated, and the radiated spectrums were measured in order to gauge spurious noise suppression and to ensure compatibility with the AN/SPS-67 radar system. The resultant data showed that the gasless electromagnetic interference (EMI) filters developed for the spurious noise suppression of the AN/SPS-67 radar system were, in fact, compatible with the AN/SPS-67 radar system and did not degrade the performance of the AN/SPS-67 radar system. The waveguide filter was then subjected to an unpressurized environment and a maximum peak power equivalent to that of the AN/SPS-67 radar systems of 285 kW peak power (214 W average power). At 285 kW peak power, a transmitter ON/Off test was conducted to confirm that no arcing would occur when this maximum power was introduced and interrupted in the unpressurized environment. The power was then increased up to the maximum of 570 kW to verify the 300% safety factor requirement. A photograph of a waveguide filter power test is shown in Figure 4; Figure 5 shows me holding the filter.

Clearly, the spurious noise issue was a problem for the AN/SPS-67 radar, and it presented significant challenges as a solution was steadfastly pursued. Fortunately, through hard work and determination, a solution was found and, as a result, this navigation radar will operate more effectively and accurately, enhancing the Navy's navigation capabilities today and in the future.

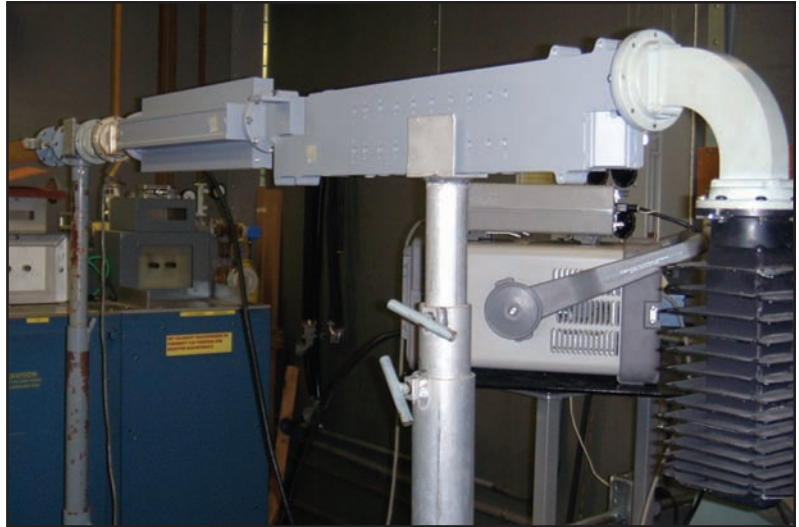

Figure 4. Waveguide Filter Connected to 1 Megawatt Magstand for Power Test



Figure 5. Author with AN/SPS-67 Waveguide Filter

NEW BROADBAND SATELLITE TERMINALS INSTALLED ON SMALLER SHIPS

By Wayne Gaston



The Naval Surface Warfare Center, Dahlgren Division's (NSWCDD) Electromagnetic Effects Division supported the recently completed installation of a "first in class" Commercial Broadband Satellite Program (CBSP) antenna system on board the Little Creek-based Patrol Coastal (PC) ship USS *Hurricane* (PC 3) (see Figure 1). The installation, which was completed with close coordination with the Program Executive Office, Command, Control, Communications, Computers, and Intelligence Office (PEO C4I); the Space and Naval Warfare Systems Command (SPAWAR); and the Patrol Coastal Squadron (PCRON) provides the ship—and eventually the entire class—with at-sea, broadband connectivity for the first time.

The CBSP replaces the older satellite system, INMARSAT, which is no longer capable of providing the necessary bandwidth to support the Navy's requirements for tactical operations or the shipboard environment for today's modern sailor. It is part of a SPAWAR program to deploy a new generation of shipboard satellite terminals that will enhance the bandwidth for ships as much as 10 times faster than previous versions, up to 3.8 megabits per second (Mbps) in a constant "on" connection. The systems are also much smaller and can be installed on almost any naval platform without taking valuable real estate from other warfare systems. The newer satellite system enhances interoperability for all warfighters, whether assigned to aircraft carriers, amphibious assault ships, cruisers, guided-missile destroyers, or even 180-foot PC ships. Sailors have a win-win situation no matter where they are stationed. They will be able to transmit voice, video, and data much faster to stay connected in our global 24/7 environment.

For USS *Hurricane* and the rest of the Navy's PC ships, there's more than just the antenna system. CBSP will support an entire new:

- Program of Record (POR) network system that includes Secret Internet Protocol Router Network (SIPRNET)
- Non-Secure Internet Protocol Router Network (NIPRNET)
- Integrated Shipboard Network System (ISNS) servers and switches
- Combined Enterprise Regional Information Exchange System (CENTRIX) servers
- Automated Digital Network System (ADNS) components

The new local area network (LAN) is also tied into the ships' private branch exchange (PBX) switches for secure telephone operations.

With crews of about 25 sailors, PC ships will now be outfitted with 22 total personal computer/





Figure 1. USS *Hurricane* (PC 3) returns 23 October 2008 to homeport, Little Creek Amphibious Base Norfolk, having completed sea trials and System Operation and Verification Testing (SOVT) for its newly installed CBSP Small Ship Variant (SSV) communications terminal.

printer drops, of which 13 will be for unclassified systems, 7 will be for classified information, and 2 will be CENTRIX terminals. They will be used by 17 Dell D630 laptops and 5 HP4250 printers. The ship's ADNS will provide ship and shore internet protocol connectivity, automating the routing and switching of tactical and strategic C4I data among and between deployed battle groups and the Defense Information Systems Network. One component of the CENTRIXs will allow the ship to have "same time chat," which is the primary method of sharing real-time information among ship and shore commands. The next two PCs to get this new configuration of CBSP and PC NETWORK are USS *Chinook* (PC 9) and USS *Sirocco* (PC 6), both homeported in Bahrain. If all goes as planned, all PC-class ships should have their new systems installed by the end of 2009.

To facilitate the design and system characteristics to help meet installation and operational criteria, NSWCDD has been an integral part of an integrated planning team with the system's program managers (PMW 170) from the beginning of this initiative. Using historical electromagnetic compatibility (EMC) data, along with shipboard and on-site testing and analysis, a Dahlgren team of EMC engineers continues to work with the

CBSP program managers to ensure that the Navy receives the best possible satellite terminals. They also provide the technical leadership to mitigate electromagnetic interference (EMI) with any and all systems being installed, whether they are below-deck wireless systems or topside warfare and communications configurations. From results of the initial EMC certification testing on board USS *Hurricane*, the CBSP system indicates that the hard work and integrated planning by all parties will pay great dividends to all, especially the fleet sailor.

USS *Hurricane*'s Commanding Officer, Lieutenant Commander John Barsano (see Figure 2), and Communications Specialist IT1 Evan Weber, provided direct support with all phases of installation of the upgrades. They coordinated the testing events needed for CBSP systems operations and the verification tests by SPAWAR, and both the EMI characterization testing and the EMC certification by NSWCDD. Without the direct involvement of both Barsano and Weber, under strict time constraints, completion deadlines might have been missed, placing both installation and testing phases in jeopardy. By meeting all deadlines, it was then possible to meet follow-on NSWCDD and SPAWAR deadlines to ensure that the next SSV installed on

USS *Chinook* would have the EMI upgrades needed as a result of all previous testing. USS *Chinook*'s install remains on track for early 2009 completion, with the remaining PCs and mine countermeasures (MCM) ships to follow.

Even though there are many unknowns regarding the new system and how it will perform in its intended operating environment, both Barsano and Weber believe the new system will greatly enhance the overall warfighting readiness of the entire Navy. Being the first PC ship to have this capability provides the ship's crew the opportunity to acquire the most experience and skills in troubleshooting any issues that might arise. They will also provide invaluable feedback on the system. This is very important, especially with regard to EMI issues, to ensure the best EMC posture that a fleet can have during a wartime environment. Weber

also believes that the ability to use "CHAT" on SIPR and CENTRIX with U.S. and Allied commanders is a major enhancement to the role the PCs play in the Persian Gulf. While this new technology has many pros for both sailors and fleet commanders, there will likely be "unknowns" regarding the limitations and risk associated with the system. Referring to the various environments the new system will be subjected to, both SPAWAR and NSWCDD will be relying on sailors to also provide feedback on operational and interoperability issues that can be used for continued system improvements. With the continued cooperation of USS *Hurricane*'s crew (as well as subsequent ships), the CBSP Program should continue to improve the scope of naval communications and allow sailors to get up-to-date information and be part of the "constant on" generation.



Figure 2. On 4 December 2008, IT1 Evan Weber (left) and Commanding Officer, Lieutenant Commander John Barsano (right), stand on the deck of USS *Hurricane* (PC 3) with the new CBSP satellite terminal.

USE OF RADAR-ABSORBING MATERIAL TO RESOLVE U.S. NAVY ELECTROMAGNETIC INTERFERENCE PROBLEMS

By Bill Marker

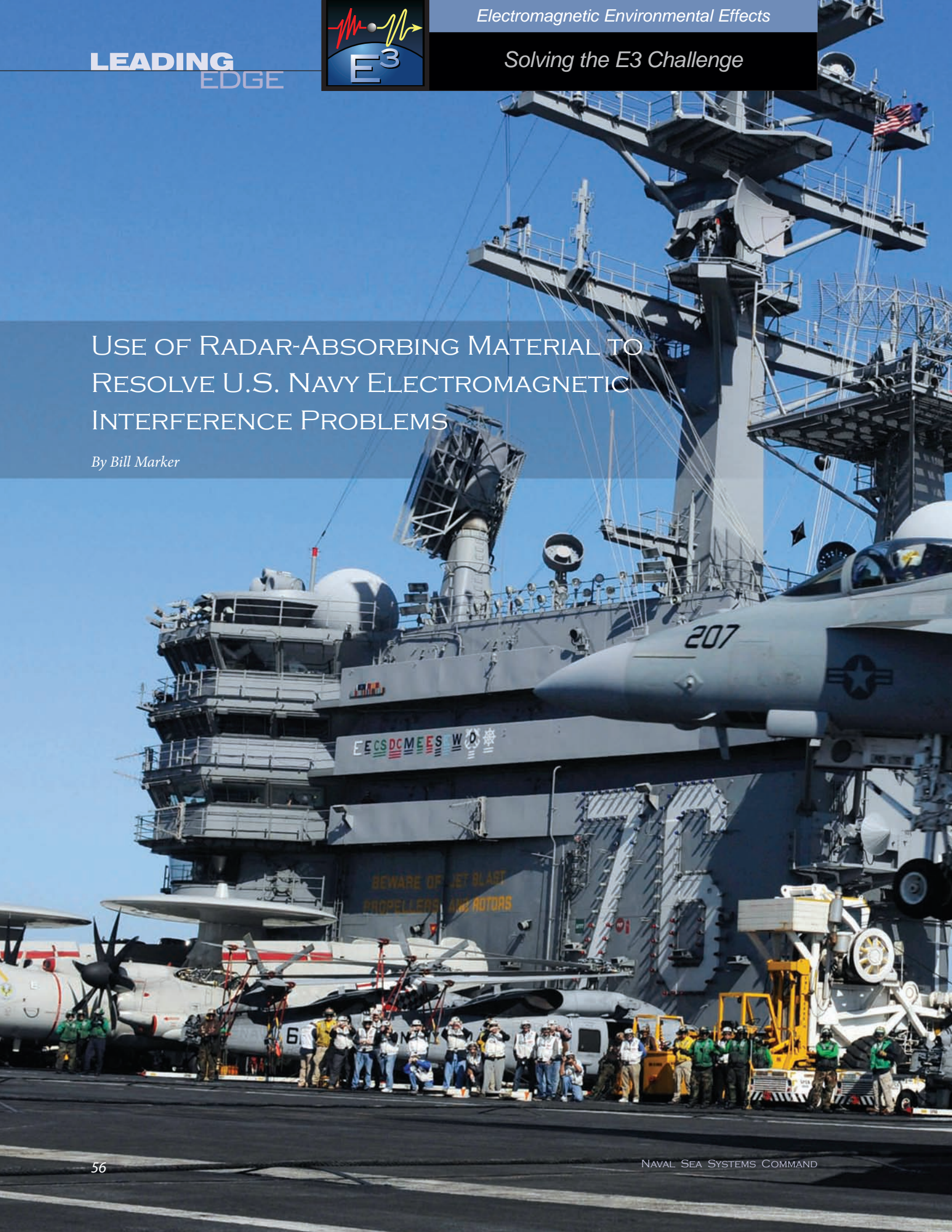

INTRODUCTION

The topside environment on today's typical U.S. Navy ship is a complex electromagnetic (EM) conglomeration of radar, navigation, communications, fire control (FC), and electronic warfare (EW) systems all trying to operate simultaneously in an extremely small area. Due to high output power requirements, overlapping operating frequencies, and sensitive receiver requirements, numerous interoperability problems can occur among shipboard systems.

One of the proven methods for resolving (or reducing to an acceptable level) some of these severe EMI problems is with the use of radar-absorbing material (RAM). RAM can be used to increase electromagnetic compatibility (EMC) among shipboard systems by providing isolation between source and victim equipment, by increasing antenna-to-antenna decoupling, and by reducing false targets resulting from signal reflections from ownship structures such as masts, yardarms, and bulkheads. In general, RAM is a multilayered material that contains at least one resistive layer. When applied to a radio frequency (RF) energy-reflective surface, some of the incoming or incidental RF energy is absorbed as it passes into the RAM, and the remainder is canceled by the reflected (180-degrees-out-of-phase) energy within the confines of the RAM. Currently, there are several types of RAM being used on U.S. Navy ships to resolve EMI problems among sensitive electronic systems. RAM is also used to reduce the radar cross section (RCS) or EM signature of Navy ships, but this article will focus on the various types of RAM utilized by the Navy for EMI reduction, including design material pros and cons, trade-offs, and maintenance issues faced by the fleet.

BACKGROUND

The Shipboard Electromagnetic Compatibility Improvement Program (SEMCIP) was founded in 1973 in an effort to combat the growing number of EMI problems that plagued the fleet. SEMCIP engineers spent many days and long nights at sea investigating, troubleshooting, and successfully resolving EMI problems. Early on, most types of fixes employed by SEMCIP involved the use of filters, blankers, bonding and grounding, or tuning (frequency management) to reduce or eliminate the EMI problems. SEMCIP engineers were very successful at resolving the majority of the known EMI problems, but certain "reflection" problems could not be resolved using traditional EMI fix methods. However, with the introduction of RAM

in the late 1970s, the SEMCIP engineers were able to

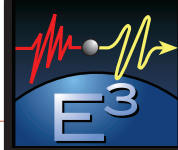

arsenal was now complete, and the battle against the unresolved EMI problems could continue to be fought and won. The NSWC Dahlgren RAM Installation Team (RAMIT)—consisting of government and contractor EMI experts in the field of RAM—was subsequently formed to investigate and resolve RAM-related EMI issues in the fleet.

TYPES OF RAM

When considering the use of RAM for shipboard EMI reduction, there are basically two types to choose from. **Narrowband** or “tuned” RAM is one in which its peak performance is focused to a specific, narrow frequency or frequency band. This type of RAM is more likely used for attenuating the undesired output from a radar or other type of system that transmits a narrow frequency spectrum. On the other hand, **broadband** RAM has its performance spread out over a wide frequency range. This type of RAM is more likely used for simultaneously attenuating the undesired emissions from an EW system or several narrowband systems, where attenuation of signal energy across a wide band of frequencies is required. In general, greater attenuation performance (25–30 dB) can be achieved with a tuned RAM, but the performance is available only over a narrow frequency range. A broadband RAM will provide somewhat less attenuation performance (15–20 dB) but will do so over a much wider frequency range. This is but one of several engineering trade-offs that the SEMCIP engineer must address when using RAM to resolve an EMI problem.

RAM DESIGN TRADE-OFFS

When it comes to selecting a particular RAM for shipboard use, there are several trade-offs the EMC engineer must consider. While the frequency of operation and attenuation performance are usually the primary determining factors, maintainability, durability, weight, color, material sizing and, of course, cost are also critical factors in the equation.

- **Maintainability:** One of the biggest drawbacks to using RAM is the need to maintain it. High heat, exhaust stack gases, wind, salt, and freezing temperatures of the shipboard environment are extremely hard on RAM. All of these contribute to the rapid deterioration of RAM if it is not properly maintained. Today’s RAM is very durable, but all shipboard EMI RAM requires painting. Painting of the RAM not only protects it from the environment but also allows it to visually blend in with the surrounding surfaces. When it

is properly maintained and painted “haze gray,” it is sometimes hard to notice that it is installed. However, maintaining RAM that is installed on the mast or yardarms is difficult, as staging/scaffolding is often required to access the RAM. Therefore, when RAM is installed in these locations, it might be better to use a carbon-loaded silicone material since it tends to hold the paint longer than some others.

- **Durability:** Depending on the installation location of the RAM, durability of the material must be considered. If the material will be in an out-of-the-way, out-of-reach location, durability of the material is not as crucial, and a less durable, better performing material may be used. However, if the material will be installed in a high-traffic or easily reached area, then a more durable material should be considered. Iron-loaded urethane RAM is very durable, while carbon-loaded silicone RAM has better performance but is not nearly as robust.
- **Weight:** Shipboard RAM used today can be designed to operate fairly well down to about 2 GHz, and tuned RAM that provides about 15 dB of attenuation at that frequency is readily available. However, once one goes below 2 GHz, the performance begins to drop off, and another undesired trade-off begins to emerge—weight. Weight is an unfortunate characteristic that becomes a factor in RAM at low frequencies due to the primary material used in the RAM’s composition—iron. Also, as the desired frequency of operation decreases, the corresponding thickness of the RAM increases. Carbon-loaded silicone RAM tuned to 3 GHz might weigh about 1 lb/ft², but an iron-loaded urethane RAM tuned to 1 GHz weighs about 8 lb/ft². If the material is being installed on the ship’s hull or superstructure, the added weight may not be much of a factor. But if it is being installed on the mast or yardarms, it can definitely be a factor, depending on the quantity required.
- **Color:** While all of the shipboard RAM must be painted, some of the RAM vendors can supply certain types of RAM that is color-matched to the ship’s haze-gray exterior and does not require painting. Currently, there is no color-matched RAM being used on U.S. Navy ships for EMI control; the reason is that after the RAM is installed, all of the edges must be caulked in order to prevent water intrusion and promote long-term adhesion.

Since the optimal sealing caulk is not available in haze gray, painting is still required to make everything blend with the topside surroundings.

- **Material Sizing:** Depending on the quantity of RAM needed for a certain application, the available size of the RAM may drive which type is selected. Most RAM is available in 12"×12" tiles, and many of the carbon-loaded and iron-loaded types can be manufactured in 18"×18" and 24"×24" sizes. One of the neoprene-based materials is manufactured to 36"×48" tiles and others are available in 36"-wide rolls of any length.
- **Cost:** In these days of shrinking budgets and program cuts, cost-reduction efforts are now, more than ever, a factor in Navy acquisition and maintenance. When it comes to employing RAM as an EMI fix, the goal of the EMC engineer is to provide the ship with the best possible fix for the lowest cost. All of the RAM procurement factors must be considered in order to arrive at the best overall solution. Sometimes this may require using a material that initially costs more per square foot but will require less funding to maintain over its expected life cycle.

INSTALLATION AND MAINTENANCE

Whether it is used for EMI or RCS reduction, the following installation and maintenance concepts are applicable to all RAM installations:

- Years ago, both the thickness of the adhesive used for the installation of RAM tiles and the corrosion of the surface underneath the RAM were factors that affected the operating frequency of the RAM. Consistent thickness of installation adhesive in accordance with the manufacturer's specifications will result in consistent performance. This is not really an issue today since all RAM procured for Navy use is supplied with a pressure-sensitive adhesive (PSA) or "peel-and-stick" backing. When the adhesive is factory-supplied with the RAM, the thickness of the adhesive is maintained within pre-established tolerances, thus ensuring consistent RAM performance. Warm, dry weather conditions are desired for RAM installation, and a surface temperature of 50°F is required for optimum adhesive performance.
- Once the RAM tiles have been installed, all of the exposed seams and edges must be caulked in order to prevent water intrusion

and promote long-term adhesion to the mounting surface.

- After the caulking has dried, all RAM must be painted. Care must be exercised to ensure that RAM surfaces are never coated or painted with any substance that affects its ability to absorb RF energy. Only latex-based paint should be used on RAM surfaces exposed to the elements. Metallic-based or epoxy-type paints normally found on board ships should never be used for RAM preservation or identification.
- Proper RAM installation is the paramount step to ensuring that the designed performance is attained and sustained. If properly installed and maintained, the useful service life is estimated to be a minimum of 5 years and, in most cases, significantly longer. Some ships have RAM that has been installed for 12 years and is still in good condition.
- Planned Maintenance System (PMS) procedures have been developed and implemented by NSWC Dahlgren's Electromagnetic Environmental Effects (E3) Force Level Interoperability Branch for all EMI-control RAM in the fleet. Ship's force FC, electronic technician (ET), and EW personnel are the ones who are responsible for performing the PMS on the RAM as it applies to their systems. The PMS consists mainly of a biannual inspection of the RAM and an annual (or "as-needed") paint requirement. When repair of the EMI RAM is required, the ships are instructed to contact NSWCDD for assistance.

Figures 1 and 2 show a typical RAM installation; note that the new RAM tiles are black. Figure 3 shows the completed RAM installation; the installed RAM tiles now blend in with the rest of the ship's topside structure.

THE WAY AHEAD

Significant advances have been made over the last several years as to the technology and raw materials available for RAM design and fabrication. The use of iron-loaded RAM (which historically has been a popular choice but has a major drawback in that it tends to rust if not constantly maintained) has been somewhat phased out by the development of iron silicide, a similarly durable material that will not rust. Precurved RAM—for use on masts, yardarm supports, and other curved surfaces—has contributed to higher installation quality. Also, neoprene-based broadband RAM is now available in extra-large tile



Figure 1. X-Band RAM Installation on USS *Ronald Reagan* (CVN 76) Stubmast

sizes, thus reducing installation and maintenance costs, while increasing the service life due to higher quality installations. Quarterly working-group meetings are held with the RAM vendors to review the latest technological advances in the market and to ensure that emerging Navy RAM requirements continue to be addressed and resolved. These advances, combined with proper RAM maintenance, will help to ensure that the Navy's radar, navigation, communications, FC, and EW systems all will be able to operate simultaneously despite high-output power requirements, overlapping operating frequencies, sensitive receiver requirements, or other interoperability or interference issues. Consequently, our naval warfighters can remain confident that their systems will work effectively as they execute their missions.



Figure 2. X-Band RAM Installation on USS *Ronald Reagan* (CVN 76) Stubmast Showing New (Black) Tile

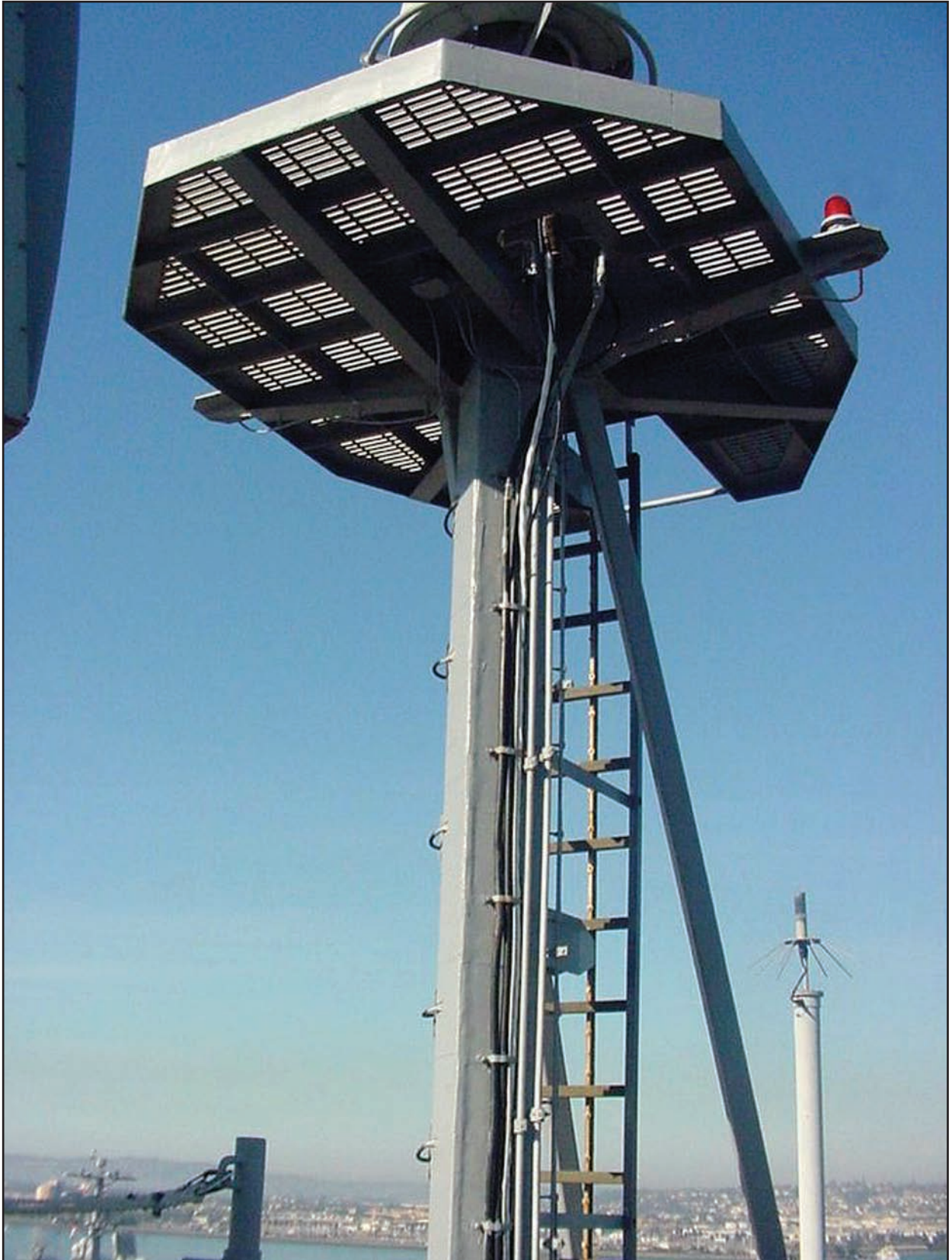



Figure 3. Completed X-Band RAM Installation on USS *Ronald Reagan* (CVN 76) Stubmast



COMPLEX CAVITIES: ASSESSING THE ELECTROMAGNETIC ENVIRONMENT OF BELOW-DECK SPACES IN NAVY SHIPS

By Gregory B. Tait and Michael B. Slocum

INTRODUCTION

With the proliferation of wireless systems currently being deployed in below-deck spaces on Navy ships, it is critical to assess the resultant electromagnetic environment of these confined, highly reflective cavities, especially where potentially disruptive or harmful effects to electronic equipment (electromagnetic interference/electromagnetic vulnerability (EMI/EMV)) or hazards to ordnance (HERO) may exist. In addition, these same wireless components and systems, with their associated risks, are being installed in similar confined, reflective spaces in ashore facilities. Examples of complex cavities or spaces include below-deck compartments aboard Navy ships, ammunition bunkers, aircraft cabins and bays, and buildings such as hangars and prefabricated metal storage facilities. As shown in Figure 1, it is often necessary to utilize any available area for temporary storage and assembly of ordnance in support of a broad array of mission requirements. Of particular significance is the introduction of radio frequency identification (RFID) and wireless local area network (LAN) systems in these spaces. Consequently, in assessing the potential impact associated with using radio frequency (RF) transmitters in reverberant spaces, we must address the cumulative buildup of the electric fields.

The Naval Surface Warfare Center (NSWC) Electromagnetic Effects Division, located in Dahlgren, Virginia, was instrumental in pioneering the use of reverberation chambers as electromagnetic test facilities. These efforts contributed greatly to an understanding of RF propagation within enclosed, electrically reflective boundaries. It became readily apparent that the statistical analysis techniques developed for use with reverberation chambers are well suited for application in defining electromagnetic environments within any such enclosed volumes. Figure 2 shows one of Dahlgren's reverberation chambers, which is typically used to assess electromagnetic compliance of various electrical or electronic weapons and control systems.

ELECTROMAGNETIC ENVIRONMENT

The term *electromagnetic environment* is used to describe radiated electric fields generated by both intentional and unintentional sources of RF transmissions. These



Figure 1. During Gulf 1, space constraints required that ordnance be staged in a carrier's mess deck.



Figure 2. Dahlgren Reverberation Chamber

fields propagate as wave energy in an open air (free space) condition and attenuate at a rate of $1/r^2$, where r is the distance from the source. In an enclosed, electrically reflective space, such as a ship's compartment, this energy repeatedly reflects off of walls and other metallic structures. Accordingly, free-space attenuation is no longer applicable as these reflections combine together, effectively increasing the resultant electric field intensity.

Just as the propagation within such spaces is unique, characterization of the electromagnetic environment within requires a unique approach. Such characterizations are conducted using a spatial or volumetric methodology in place of the line-of-sight techniques used for free-space environments. Studies conducted at NSWC Dahlgren have demonstrated that such reverberant spaces can be characterized using either of two techniques. The first is to physically stir the energy within a space using large, electrically conductive tuner assemblies,

while simultaneously measuring the resultant electric field intensity. This technique is shown in Figure 3.

The second technique is to physically move (carry) both the transmit and receive antennas throughout the space, which results in sampling the electric field intensity at many locations and orientations. It has been demonstrated that the two measurement techniques are equivalent. This equivalence is important, as setting up and operating large tuners for effective mechanical stirring of the fields is not practical in the characterization of a large number of spaces aboard a ship. It is thought, however, that the changes in the cavity boundary conditions—such as from movement of personnel, equipment, and materiel—will stir the fields to a large extent over a longer period of time. The second technique, therefore, has proven to be the better approach due to the operational constraints of conducting such characterizations outside of a



Figure 3. Energy Stirring Using Tuner Assemblies Aboard USNS *Sacagawea* (T-AKE 2)

laboratory environment. Figure 4 depicts the test equipment utilized in this preferred technique.

In conducting these measurements, limitations exist on test time, working volume (with minimal disruption of normal functional operations), test equipment (number, weight, and size), availability of AC power, manpower, and cost. These challenges are common to both ashore and afloat facilities. From measurements of power insertion loss in the space, a cavity calibration factor is derived that is used to predict a resultant maximum diffuse electric field as a function of frequency and total radiated power in that space. Due to the additive nature of multiple RF emitters in confined, highly reflective spaces, the potential exists for maximum fields to exceed current HERO unsafe criteria in ordnance magazines and assembly areas, which could result in dudding or premature detonation of ordnance. The latter poses serious risk through loss of life and, in the extreme case, could destroy the ship

or platform carrying such ordnance. Consequently, the ability to predict maximum electric fields in a space will be critical for placing restrictions on the number of RF emitters allowed in that space.

There are two general requirements for a space to be reverberant:

1. The space must be large in terms of the wavelength (overmoded).
2. The space must be reflective of electromagnetic energy (many reflections of waves).

Therefore, the field at any point within some working volume consists of a large number of individual wave components that, upon effective mode stirring, generate a field that is statistically uniform, isotropic, and randomly polarized. In reverberation chamber test facilities, these conditions are met, usually with a large mechanical tuner providing effective mode stirring. In many field-operational spaces, the conditions that the cavity be overmoded and reflective are generally fulfilled at

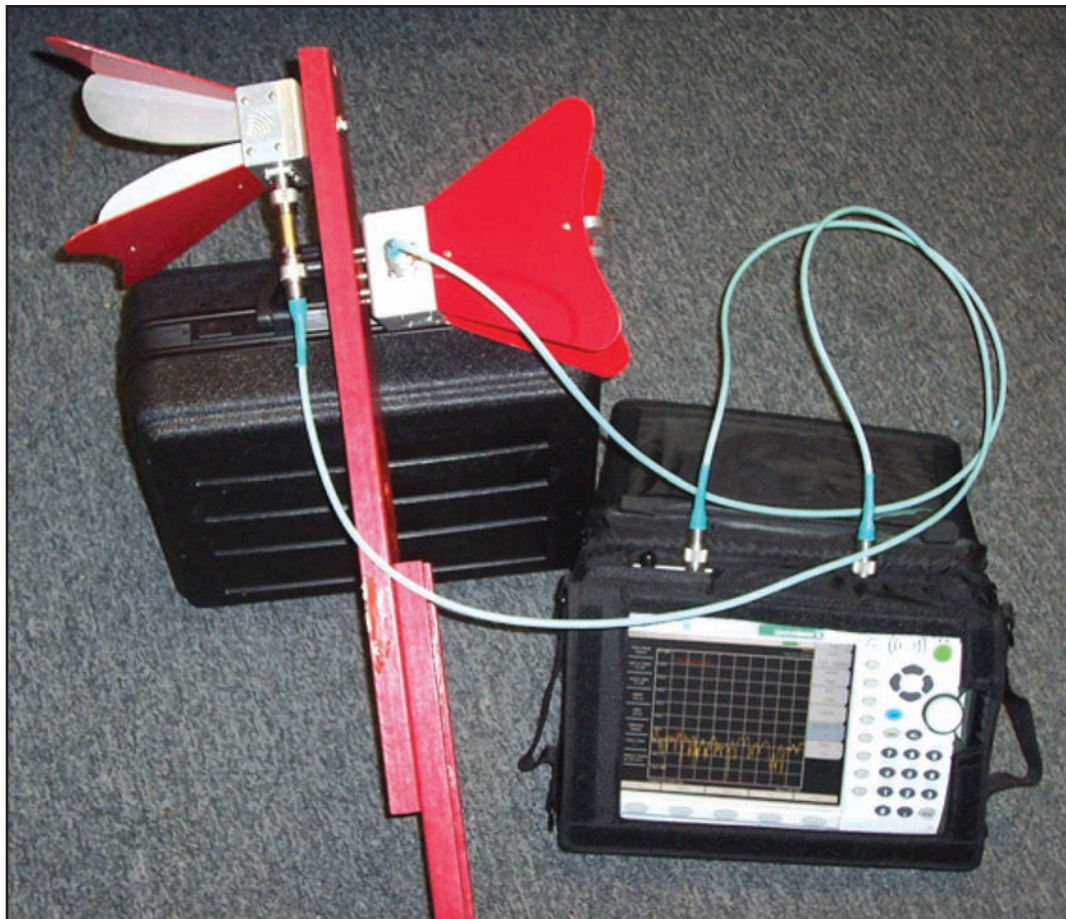

Figure 4. Test Instruments Used in Preferred Measurement Technique

frequencies of interest. A similar situation has been found to exist in aircraft cavities.

Electrically large and reflecting spaces with arbitrary shape and loading are often referred to as complex cavities. The complex cavity is characterized by a chaotic electric field standing-wave pattern of maximums and minimums whose locations are very sensitive to small changes in boundary conditions, such as occur from changes in physical structure (mechanical stirring), frequency (frequency stirring), loading (materiel, personnel, equipment), temperature, etc., over a period of time. Figure 5 shows a computer-generated visualization of the rapidly and randomly varying spatial field pattern in a complex cavity. A deterministic analysis, either by measurement or by modeling/simulation of such chaotic fields is neither practical nor useful, as substantial changes are caused by perturbations. Useful descriptions must be statistical in nature and independent of details.

APPLICATION OF THEORY

With sufficient number of modes excited in a complex cavity, the central limit theorem of

statistics states that the field components are normally distributed with zero mean and equal standard deviation. Hence, the received power of a linearly polarized antenna in the space should follow a chi-squared distribution with two degrees of freedom (χ_2^2) as the receive antenna position is randomly changed. Demonstration of χ_2^2 statistics in the space is a good indicator of its reverberant nature and allows us to exercise the appropriate statistics to predict such things as maximum field values within specified levels of confidence.

To date, the Electromagnetic and Sensor Systems Department engineers from NSWC Dahlgren have measured the electromagnetic environments in over 60 below-deck compartments in several ships (T-AKE 2, LHD 5, LHD 7) in port at Naval Station Norfolk. Figure 6 shows a measurement in progress. It was found that these spaces can be characterized as complex reverberant cavities that can sustain fairly high maximum electric field levels over the 200 MHz to 10 GHz frequency range. Due to the cumulative build-up of electric fields from multiple radio-frequency emitters, care must be exercised to assure that

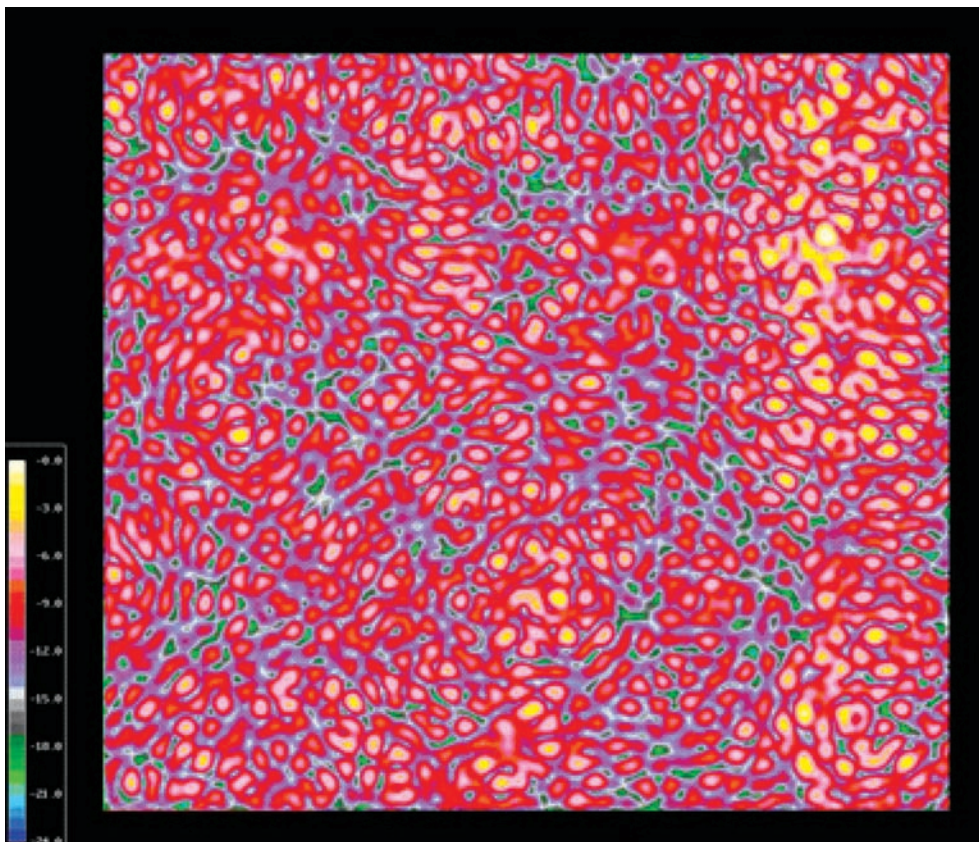

Figure 5. Computer-Generated Visualization of the Chaotic Electric Field Standing Wave Pattern in a Reverberant Complex Cavity

the maximum allowable environment for electronics and ordnance is not exceeded. As an assessment figure of merit for below-deck spaces, a cavity calibration factor is derived from measured power-insertion loss data and is used to estimate field strengths as a function of frequency and total radiated power into the space. Typical maximum cavity calibration factors range from 1–10 V/m/ \sqrt{W} in ordnance magazines, operations centers, and electronics rooms to as much as 10–20 V/m/ \sqrt{W} in small, highly reflective pyrotechnics storage compartments. Guidelines for allowable total transmitter powers for RFID and wireless LAN systems are established from the results of this investigation.

CONCLUSION

Due to ever-increasing pressures on our Navy to provide a dominant presence in remote portions of the world with fewer ships and personnel, we are more dependent on technology than ever

before in naval history. One of the primary roles NSWC Dahlgren plays in supporting this technology boom is to assure that such systems are both capable and safe for fleet operations in a severe electromagnetic environment. The scientists and engineers of Dahlgren charged with this task support Naval Sea Systems Command (NAVSEA) as the engineering agent for the electromagnetic effects warrant holder's office (05W43), as well as the Naval Safety and Security Activity (NOSSA) through compliance evaluations and managing the Navy's Hazards of Electromagnetic Radiation to Ordnance (HERO) program. Unlike other services deployed in our nation's defense, our sailors literally sleep on their ordnance, and they are counting on us to ensure that it is both safe and functional. To that end, assessing the electromagnetic environment in below-deck spaces in Navy ships enables improved warfighter efficiencies by leveraging technologies such as wireless LAN and RFID in a safe and reliable manner.



Figure 6. Dahlgren engineers conduct an electromagnetic assessment in a radio transceiver room aboard the amphibious assault ship USS *Iwo Jima* (LHD 7).



THE DEPARTMENT OF THE NAVY'S HERO PROGRAM

By Charles C. Denham





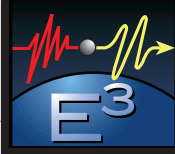

INTRODUCTION

The Department of the Navy (DON) has an established and comprehensive Hazards of Electromagnetic Radiation to Ordnance (HERO) Program. This program is critical in ensuring a safe environment, both afloat and ashore, for the safe handling of ordnance without compromising operational flexibility and readiness. This article describes the Navy's overall HERO Program, important elements of the program, some history behind the program, and how the program has evolved over the years to get where it is today.

HERO DEFINED

The HERO discipline is concerned with the electromagnetic environment (EME), in which electrically initiated ordnance will be exposed while performing its intended mission throughout its operational life cycle. Consequently, HERO can be defined as the situation in which transmitting equipment (e.g., radios, radars, electronic countermeasures, ground penetrating radars) or other electromagnetic-radiating devices can generate radiation of sufficient magnitude to induce or otherwise couple electromagnetic energy, which inadvertently causes the actuation (or dud) of electrically initiated ordnance. The result is that the affected ordnance is unable to function as intended, or worse, that there is an immediate catastrophic event, which either destroys equipment or injures personnel. An electrically initiated device (EID) is defined as a single unit, device, or subassembly that uses electrical energy to produce an explosive, pyrotechnic, thermal, or mechanical output. Examples include electroexplosive devices such as hot bridgewire, semiconductor bridge, carbon bridge, conductive composition laser initiators, exploding foil initiators, burn wires, and fusible links, all of which have different response characteristics. For HERO, the EME is defined as the totality of electromagnetic energy—both intentional and unintentional radiation—to which platform/system or subsystem/equipment will be exposed within the land, air, space, and sea domain, while performing its intended mission during its stockpile-to-safe separation sequence. The HERO problem arises from a fundamental incompatibility between EIDs and their firing circuits and the external EME that the ordnance encounters.

HISTORY AND PHILOSOPHY

As early as the 1940s, a number of unexplained accidents involving electrically initiated ordnance were suspected to have been directly

related to stray radio frequency (RF) emissions. In the 1950s, an Mk 6 Mod 13 torpedo exploder mechanism was known to have been set off by RF energy. Around this time, a number of other aircraft carrier HERO incidents were also documented. Consequently, in 1956, the Chief, Bureau of Ordnance initiated a formal HERO Program at the Naval Surface Warfare Center, Dahlgren Division (NSWCDD), then known as the Naval Proving Ground (NPG), Dahlgren. For the next 3 years, the development of the HERO Program was primarily one of organization, both philosophically and practically. In late 1959 and early 1960, money was appropriated to build the first ground plane to support HERO testing. By 1963, the Navy HERO Program expanded in response to a requirement to test all ordnance containing EIDs, which has become one of the fundamental pillars of the program. To accommodate this effort, a second ground plane was built to support off-site testing at the Naval Air Station (NAS), Patuxent River, Maryland.

The year 1965 marks the introduction of the second pillar of the HERO Program: HERO shipboard and field surveys. In the early 1970s, these surveys became the direct responsibility of the Naval Sea Systems Command (NAVSEA). Throughout the years, the Navy HERO Program has continued to grow with regard to the testing of ordnance, the survey efforts, and the approaches to addressing the HERO problem in the guidance provided to the fleet. The ensuing paragraphs introduce and discuss the current philosophy for each of the Navy HERO Program core elements in an attempt to illustrate the importance of each to the overall program and why each of these program elements must continue to be maintained in order to effectively sustain the Navy HERO Program.

CORE ELEMENTS OF THE NAVY HERO PROGRAM

Traditionally, the program has identified three broadly defined core elements (or pillars) to describe the overall DON HERO Program (see Figure 1): HERO certification testing, HERO surveys, and HERO guidance. These elements, when viewed as individual parts of the overall program, represent very different, but important, efforts and together form a comprehensive HERO Program and an effective means for managing HERO and mitigating the hazards throughout the DON. For that reason, it is important to describe in some detail each of the three critical program elements to better understand how their synergy provides a total approach for managing HERO in the Navy, joint,

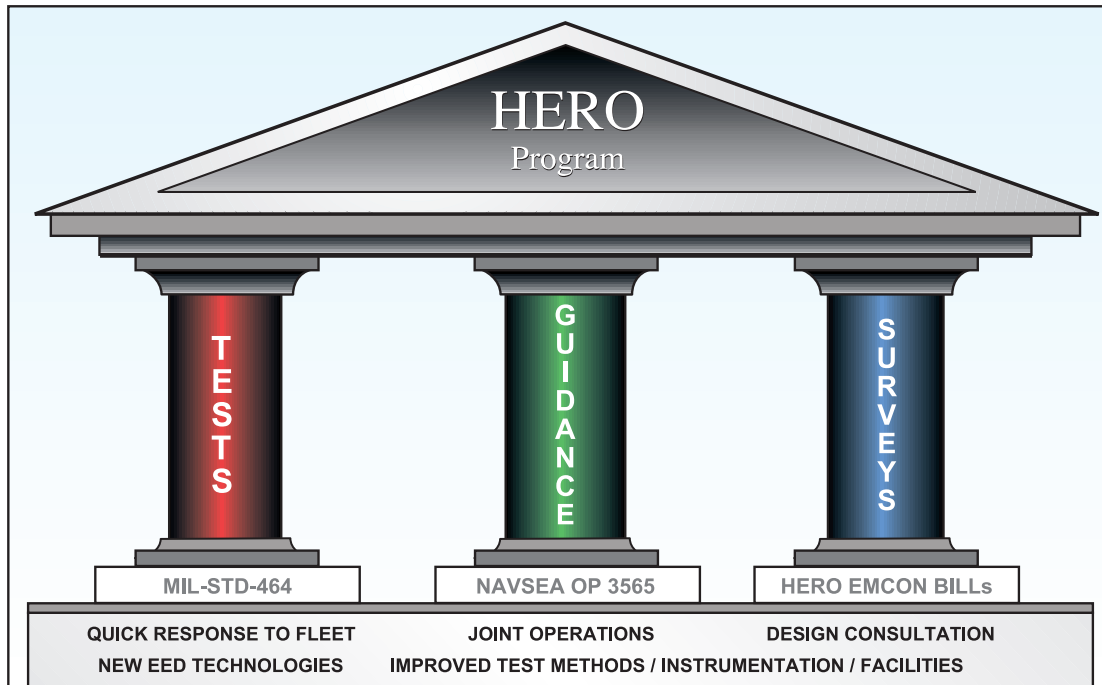

Figure 1. Pillars of the HERO Program

coalition, and North Atlantic Treaty Organization (NATO) environments. It is also important to illustrate how these program elements have matured over the years to provide the breadth and depth of the Navy's HERO Program.

HERO CERTIFICATION TESTING

Ordnance certification testing (or HERO testing) is an important element of the HERO certification process. This process contains step-by-step procedures through which a program manager (PM) obtains a HERO certification or a HERO operational waiver for new or modified weapons or weapons systems containing EIDs. This certification or waiver is a mandatory milestone in obtaining an active National Stock Number (NSN) or Navy Ammunition Logistic Code (NALC) so that these weapons or weapons systems can be delivered to the fleet for use. All weapons containing EIDs are required to be evaluated for HERO as part of this process. Currently, MIL-STD-464, titled *Department of Defense Interface Standard for Systems Electromagnetic Effects Requirements*, establishes the electromagnetic environmental effects (E3) interface and performance requirements and verification criteria for systems. The HERO test identifies the item's susceptibility or immunity to the operational EME and, if susceptible, identifies the maximum allowable environment (MAE) that the item can be exposed to during its stockpile-to-

safe separation sequence. It should be emphasized that testing is the preferred means of determining how an ordnance item will respond to the expected EME.

As stated previously, HERO testing should include exposure of the ordnance to the test EME in all life-cycle configurations, including transportation and storage, assembly, handling and loading, staged, and pre- and post-launch (see Figure 2). There are many other things to consider during the HERO test in order to ensure that the item has been properly evaluated. First and foremost are the description and characteristics of the EIDs contained in the system under test (SUT), how these EIDs are used, and their firing effects. Technical details—such as the type of EID, the bridgewire resistance, the firing sensitivity, the thermal time constant, and the firing consequence (safety/reliability)—are necessary in order to predict potential susceptibilities and determine instrumentation requirements. Other details must also be considered, such as firing circuit designs, system wiring and cabling, gaskets, connectors, shielding, and the SUT's physical dimensions.

Somewhat unique to the Navy is the test approach whereby all stockpile-to-safe separation configurations are evaluated during ordnance testing. Inasmuch as ordnance configurations can be expected to offer different levels of RF protection, all must be given due consideration. With many

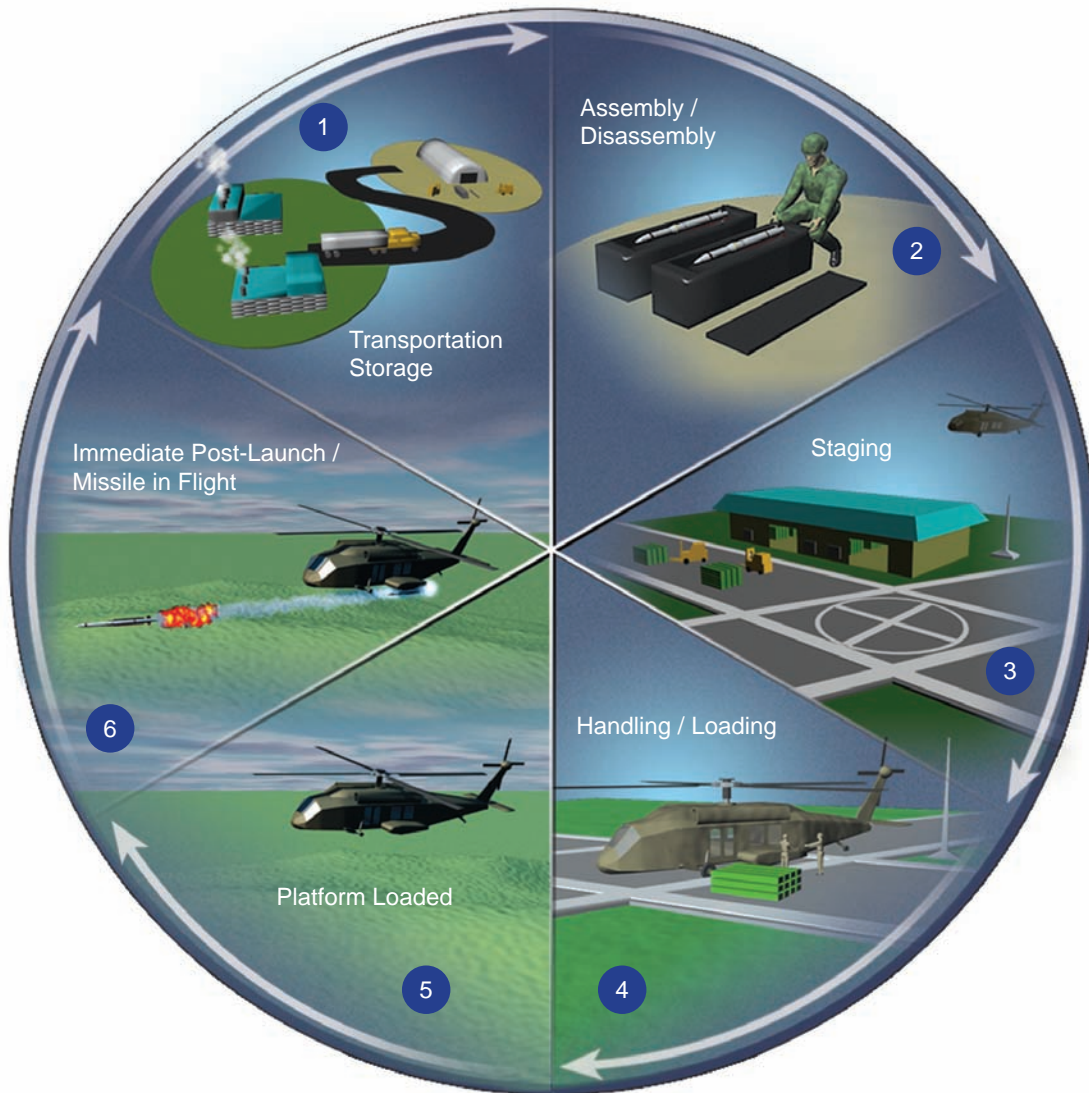

Figure 2. Ordnance Stockpile-to-Safe-Separation Sequence

ordnance items, the host platform/system (e.g., airframes, bomb racks, dispensers, or interface cables) varies as it progresses through the stockpile-to-safe-separation sequence, and these differences can have a pronounced influence on the amount of RF coupling. Furthermore, it can be expected that the EME associated with each will be quite different and, therefore, must be fully understood. The test EME should simulate the specified operational EME to the extent necessary to stimulate maximum EID and firing-circuit responses. In order to stimulate the specified operational EME, frequency, power levels, polarization, illumination angle,

pulse widths, pulse repetition frequencies, and dwell times must be carefully chosen, and ordnance stockpile-to-safe separation configurations must be fully understood. Thus, it becomes immediately obvious that the HERO survey process is critical to the certification testing process, as this is where operational EMEs are characterized, and specific ordnance configurations and procedures are identified.

Ultimately, all of the aforementioned HERO test criteria are considered in order to ensure test standardization within the Navy HERO Program. The Navy's test methodology is well documented

and provides a strong foundation on which Navy HERO certification relies. This test philosophy and methodology has been documented in MIL-HDBK-240 for the other services to use as a model for HERO testing to ensure Department of Defense (DoD) consistency within the respective HERO programs. The strength of the ordnance certification testing conducted by the Navy facilitates the Navy's HERO certification process as a whole by providing important data to the Weapon System Explosives Safety Review Board (WSESRB) and NALC verification process (i.e., cataloging request) to ensure proper hazard classification and HERO certification so that ordnance systems can be safely introduced into the fleet.

HERO SURVEYS

Also unique to the Navy HERO Program is the extent to which the operational EME is characterized through HERO surveys. HERO surveys are necessary to ensure the safety of simultaneous operations involving ordnance and electromagnetic emissions from radar and communication systems. While HERO certification testing allows for defining an item's MAE, the HERO survey defines the actual operational environment that the item will be exposed to. A HERO survey is an on-site visit, in which measurements of the RF environment are made at all ordnance locations, including assembly areas, handling and loading locations, staging areas, and transportation routes. This characterization of the EME is combined with a detailed data-gathering process in which all emitter systems are documented, and all operational requirements are reviewed.

The information gathered during the HERO survey is used to prepare operational recommendations and an emission control (EMCON) bill, and often results in a more efficient use of ordnance areas, while minimizing the operation restrictions placed on radar and communication systems. Environmental studies such as these (i.e., characterization, monitoring, and documentation of EMEs), particularly aboard ships, remains a vital part of the HERO Program and allows for the translation of an extensive amount of technical HERO data into ship or site-specific (easy to use) guidance for the fleet. Surveys also serve as a means for providing critical training, as well as a tool for soliciting feedback on existing HERO guidance and operational procedures. Figure 3 illustrates the dangers of ordnance on deck being exposed to electromagnetic radiation (EMR) from powerful radar and communications emitters in the immediate vicinity.

In recent years, the HERO survey program has increased its emphasis on joint and coalition forces' operations on board Navy platforms and at forward-deployed locations. To better address these concerns, more measurements are made on the flight deck of all air-capable ships. Moreover, the Navy HERO EMCON bill (guidance) has evolved to address joint and coalition forces' operations. Data gathered during shipboard HERO surveys are also provided to other related programs that rely on the Navy to define the operational EME.

Characterization aboard ships and shore facilities are used to update MIL-HDBK-235B to address tailored EMEs and are currently being used to update the HERO certification EME tables found in MIL-STD-464. The survey data is also used to update the EME module in the Joint Spectrum Center (JSC) Ordnance E3 Risk Assessment Database (JOERAD) and is contributing to NATO's efforts to capture the NATO operational EME.

It is also important to note that knowledge of the operational EME is critical in order for weapon system programs to specify and address E3 performance-based requirements within the Operational Requirements Document (ORD), Test and Evaluation Master Plan (TEMP), and the Mission Needs Statement (MNS). Not only is it vital to characterize the operational EME as a means for E3 design, development, and test and evaluation (e.g., HERO and electromagnetic vulnerability (EMV)), but this data is necessary for managing any and all unresolved susceptibilities once introduced into the fleet.

HERO GUIDANCE

Previous initiatives have shown that HERO certification testing enables identifying the MAE that an ordnance item or weapon system can be exposed to; the survey process allows for defining the operational EME that the item will actually see.

The final pillar is the guidance that is provided and, most critical to the warfighter, is the guidance provided in the HERO EMCON bill. The HERO EMCON bill, included in the HERO instruction, is a specific set of procedures (i.e., frequency/power management or procedural management) that identifies the ordnance/weapon system scenario, the susceptibility, and the specific guidance to safely and effectively manage the event. It is the culmination of all of the efforts and data gathering of the certification testing and survey efforts, whereby specific information germane to a ship or shore facility is filtered out to provide platform/system scenario-specific HERO guidance for a defined operational EME.



Figure 3. Ordnance Exposed to Radar and Communications Emitters in the Immediate Environment

For the Navy HERO Program, guidance comes in other forms, including technical manuals, instructions, shore facility site approval analyses, shipboard system certifications, and general fleet guidance to support naval operations. *Electromagnetic Radiation Hazards (Hazards to Ordnance)* is the Navy HERO Program technical manual.¹ It provides information on how to calculate the RF environment, determine the safe separation distance for ordnance classified as either HERO SUSCEPTIBLE and HERO UNSAFE ORDNANCE, manage HERO in the NATO environment, establish a HERO EMCON Bill, and request a HERO survey; it also provides information on other general HERO requirements. The *Electromagnetic Radiation Hazards (Hazards to Ordnance) Datasheets*² provides HERO classifications (e.g., SAFE, SUSCEPTIBLE, and UNSAFE) for all ordnance evaluated and contains the Navy's susceptibility data (as a result of HERO testing). Another document generated by the Navy HERO Program is *Design Principles and Practices for Controlling Hazards of Electromagnetic Radiation to Ordnance (HERO Design Guide)*.³ The

design guide is intended primarily to assist the ordnance system developer solve the problem of premature actuation or degradation of EIDs through sound design practices.

Perhaps the best tool the Navy HERO Program has today for capturing information and providing HERO guidance is the E3 Team Online tool. The E3 Team Online is a Navy HERO Program knowledge-management system for supporting the creation, capture, storage, and dissemination of E3 information, particularly as it relates to the HERO Program. This tool, developed in the late 1990s, started out as an engineering tool to aid in the development of HERO test and survey reports and was used solely by the HERO Program engineers. Currently, the tool is being used by a number of components within the various services and, in the near future, will be available as a fleetwide tool. This management system contains the HERO database, with over 18,000 records that provides a catalog of ordnance items by NALC/Department of Defense Identification Code (DoDIC) with specific information pertaining to each item, including the current MAEs and HERO status. This database serves

as the data source for NAVSEA OP3565, Volume III and will also soon contain a cross reference table for EIDs with some 2,176 unique EIDs.

E3 Team Online also has built-in e-tools to calculate safe separation distances and MAEs and contains over 13,000 technical reports dating back to the 1960s, including all of the HERO test and survey reports. More recently, E3 Team Online now provides an interface (Platform Management Tool) to manage and retrieve information pertaining to specific ship, shore, vehicle, and aircraft platforms. Platform information includes:

- HERO reports
- Transmitter/antenna configurations
- Photos and drawings
- EME measurement data
- Ordnance listings
- Aircraft/vehicles supported
- EMCON bills

This data is used by all of the services and is used to feed information to JOERAD, the Shipboard Electromagnetic Compatibility Improvement Program (SEMCIP) Technical Answers Network (STAN) Database, and the Navy's Capabilities (CAPs) and Limitations (LIMs) Program efforts. It also supports other information sources for the fleet, such as the Naval Air Systems Command's (NAVAIR's) Air Systems Electromagnetic Interference Corrective Action Program (ASEM-ICAP) E3 Integrated Planning Team (IPT), Fleet

Combat System Operational Sequencing System (CSOSS) Development and Implementation Team, *Aegis*-class advisories and master procedures, and the integrated topside design process. In the future, E3 Team Online will provide a risk management tool and a shipboard EME prediction tool to supplement the HERO guidance capabilities (see Figure 4).

NAVY HERO PROGRAM TODAY

In the 1970s and 1980s, the Navy HERO Program performed HERO certification testing and HERO surveys. For the most part, all of the program's efforts were stovepiped into these two areas, and there was little focus on guidance or operations beyond the Navy environment. In the 1990s, the Navy HERO Program expanded in breadth and depth, and began to reach out beyond the Navy to address HERO concerns from a DoD perspective.

The program also began to work within a yearly structured business plan, such that funding and manpower was directed to other programmatic areas of concern, such as the site approval process and system certifications, the ordnance database, forward-deployed HERO support; and assurance that the various Navy and DoD instructions and publications were updated to reflect the current HERO philosophy and methodology. In addition, the HERO Program began to invest in the future by conducting HERO studies related



Figure 4. E3 Team Online



to HERO instrumentation, low-frequency/transient radiation effects on ordnance, EID technology assessments, passive/active radio frequency identification (RFID) device test methodologies and certification processes, gamma irradiation of explosives, below-deck measurement techniques and complex cavity effects, and the use of the mode-stirred chamber for HERO certification.

Inasmuch as the program placed an emphasis on defining the requirements within the appropriate DoD instructions for HERO certification testing and for establishing a HERO survey process with defined periodicities for ship and shore facilities, the number of tests and surveys increased in the 1990s. The Navy HERO Program also began to provide a DoD leadership role through its effort in the Joint Ordnance Commander's Group (JOCG) HERO Subcommittee. Through its efforts in the JOCG, the Navy provided MIL-HDBK-240, the Joint HERO curves, and the MAE tool to help ensure consistency for the services' HERO programs, particularly for HERO certification testing and joint operational HERO guidance. Today, this triservice approach to HERO continues to grow such that the services and, in particular, the Navy are better able to address HERO concerns when joint forces are present aboard naval platform and ashore.

Furthermore, through the Master Data Exchange Agreement (DEA) programs in place with the various NATO nations and the U.S. Navy's representation in the NATO Radio and Radar Radiation Hazards Working Group (RADHAZWG), the Navy HERO Program has similarly improved its capabilities to deal with coalition forces present in the naval environment. Not only has the international efforts allowed U.S. input to the development of NATO EME standards, but it has also helped ensure rationalization, standardization, and interoperability of U.S. forces in NATO operations.

Today, the Naval Ordnance Safety and Security Activity (NOSSA), located at the Indian Head Division, Naval Surface Warfare Center, Indian Head, Maryland, is designated the Navy's Technical Authority for HERO.⁴ As such, NOSSA provides policy guidance and is responsible for issuing appropriate instructions and publications necessary to implement a comprehensive program. NAVSEA issues procedures for the implementation of the DON's HERO Program and outlines the

program's requirements and responsibilities.⁵ The HERO Program encompasses the establishment and implementation of explosives safety standards, test and survey criteria, instructions, regulations, and electromagnetic EMCON procedures for radar and communication emitters throughout the DON. The instruction also designates NSWCDD as the technical agent for the DON's HERO Program.⁶ As such, NSWCDD is responsible for the engineering and technical support to evaluate all Navy and Marine Corps materiel with EIDs to determine their immunity to EMR hazards, and to perform assessments and surveys for all Navy and Marine shore facilities and ships. NSWCDD is often called upon to evaluate ordnance with a joint force application and to perform assessments and surveys of forward-deployed areas.

Consequently, today's HERO Program is more than just HERO surveys or HERO certification testing and more than just Navy concerns in the naval environment. Current and future efforts will continue to include forward-deployed HERO surveys and operational guidance from a joint and coalition perspective. Through its comprehensive program, the Navy will continue to be a repository for operational EMEs aboard ship and at shore facilities, and will continue to provide a leadership role within the DoD for all matters related to HERO. The breadth and depth of the Navy HERO Program can be attributed to its broad scope of efforts within the three major pillars of the program through which it is able to provide effective operational guidance to the warfighter while maintaining safety. As a result of the program, naval, joint, and coalition warfighters not only operate more safely, but more effectively during peacetime or war.

REFERENCES

1. NAVSEA OP 3565/NAVAIR 16-1-529 Volume II.
2. NAVSEA OP 3565/NAVAIR 16-1-529 Volume III.
3. NAVSEA OD 30393.
4. Chief of Naval Operations (CNO) and the Commandant of the Marine Corps (CMC) joint instruction, OPNAVINST 8020.14/MCO P8020.11, titled *DON Explosives Safety Program Policy and Procedures*.
5. Instruction 8020.7D, titled *Hazards of Electromagnetic Radiation to Ordnance Safety Program*.
6. IBID.



Hazards of Electromagnetic Radiation to Ordnance (HERO)





JOINT AND COALITION FORCES IN THE OPERATIONAL ELECTROMAGNETIC ENVIRONMENT

By Charles C. Denham

BACKGROUND

This article explains Hazards of Electromagnetic Radiation to Ordnance (HERO) challenges that the Department of Defense (DoD) is faced with when conducting joint and coalition operations. It describes, in some detail, the leading role the U.S. Navy has played in establishing HERO standardization among the U.S. service components through its leadership and efforts in the Joint Ordnance Commander's Group (JOCG) HERO Subcommittee. It also presents example solutions that have provided DoD-wide HERO mitigation techniques in supporting joint and coalition operations.

OVERVIEW

U.S. armed forces are involved in military operations throughout the world, including joint force operations (e.g., Air Force, Army, Navy, and Marine Corps). Many of these operations are conducted from forward-deployed areas and include coalition partners. For these armed forces to be most effective, they must be fully integrated: operationally, doctrinally, and technically.

Over the years, one of the technical challenges for the U.S. armed forces involved in joint and coalition integrated operations has been the ability to address HERO, which is defined as the ability of the operational electromagnetic environment (EME) to inadvertently induce currents and/or voltages of magnitudes large enough to initiate or dud electroexplosive devices or other sensitive explosive components of weapon systems,

ordnance, or explosive devices. Proper HERO guidance can prevent undue operational restrictions or even loss of life and mission abort. The Defense Spectrum Organization (DSO), formerly the Joint Spectrum Center (JSC), and the Naval Ordnance Safety and Security Activity (NOSSA) routinely interact with the unified combatant commands and joint task forces (JTFs), providing operational spectrum management and HERO support and, as a result, understand the need for being proactive in addressing HERO.

The (JOCG) HERO Subcommittee was established in 1994 by the JSC. Its primary goal was to establish a consolidated triservice approach to HERO to facilitate the collection, development, and dissemination of the data necessary to manage the conflict between ordnance and RF emitters employed in integrated joint operations or exercises. The Navy—because of the depth and strength of its existing HERO program, and its knowledge of the shipboard environment that routinely hosts joint operations and exercises—has been at the forefront of establishing the triservice HERO approach. Since its inception, the JOCG's main focus has been the development of HERO tools such as the Maximum Allowable Environment (MAE) Analysis Tool, the JSC Ordnance Electromagnetic Environmental Effect (E3) Risk Assessment Database (JOERAD), and the establishment of DoD-wide HERO philosophies and methodologies now captured in the *Hazards of Electromagnetic Radiation to Ordnance (HERO) Test Guide*.¹ In addition to the work done in the JOCG, the JSC and NOSSA have sponsored a number of HERO surveys at forward-deployed locations to provide HERO training and to help manage HERO from a joint perspective.

CHALLENGES

There are a number of activities within each service that are assigned various HERO program responsibilities, including both administrative and technical roles. The individual services manage HERO adequately; however, until recently, they did not have the necessary information to address ordnance safety when integrated joint operations and exercises occurred. This was particularly true in 1994 in the case of Operation Restore Democracy, where Army and Air Force helicopters, loaded with Army/Air Force ordnance, were exposed to the Navy shipboard EME off the coast of Haiti. This presented numerous concerns, in that the weapons were not designed, much less evaluated, to the Navy's unique shipboard EME. Consequently, the HERO guidance provided by the Navy

HERO program was restrictively placing a burden on the ship's ability to conduct ordnance operations while, at the same time, impeding the effective use of its radar and communication systems.

A continuing concern has been the lack of a cohesive policy within the DoD to address this issue. Due to the varied service histories, it is not surprising that service-unique approaches dealing with HERO exist. Army, Navy, and Air Force HERO programs reflect fundamental differences in the perception and magnitude of the problem. Other factors, such as the way the services store, transport, and use ordnance, as well as the practical options available for managing HERO, influence the way each service manages its respective programs. Consequently, these differences influence not only the HERO certification testing of ordnance (i.e., test philosophy and methodology), but also the guidance that is provided to mitigate the concern for HERO at the operational level. From the HERO test perspective, service ordnance may not be tested or designed for the joint integrated operational EME. Due to these differences, HERO guidance in the joint arena, particularly in the naval environment, becomes difficult at best.

Another significant difference in the services' HERO programs is the characterization of the operational EME. To date, only the Navy's HERO program has a comprehensive HERO survey process, whereby the operational EME at shore facilities and aboard ships is characterized and documented. This perhaps best reflects the different "perception of the problem" that each service has with regard to HERO. The Army and Air Force generally operate with more real estate and can apply a calculated safe separation distance between emitters of concern (e.g., radars and communication antennas) and ordnance operations without imposing undue restrictions to their operations. However, the Navy operates in limited space aboard ship and a purely theoretical approach using calculations and derived safe separation distances provides overly restrictive solutions to managing HERO. The HERO survey process has allowed the Navy to better understand the operational EME and manage the HERO problem while maintaining operational effectiveness.

Despite the differences in the way each of the services manage HERO, there are certain elements common to all of the service HERO programs. Each of the services provides a definition of the expected EME levels for all ordnance configurations, a prescribed method to quantify system degradation (i.e., deficiencies), a process to develop and validate effective, practical HERO fixes for known deficiencies, and an established means by

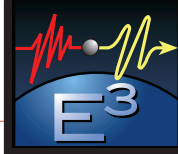

which operational procedures or restrictions are provided to minimize risks. While these commonalities exist, each service uses a somewhat different approach to manage HERO; however, these commonalities provide a starting point at which a triservice approach to HERO can be implemented. As a result, the JOCG chose to focus its efforts on the establishment of a triservice approach for HERO certification testing and the tools necessary for providing operational guidance. As a result, MIL-HDBK-240 was created, the joint HERO curves were established, and the MAE Analysis Tool was developed—all by Naval Surface Warfare Center, Dahlgren Division (NSWCDD) engineers, with input from the other services. In addition, the JOERAD database was created and populated with the services' HERO data, and forward-deployed surveys were implemented to provide training and immediate operational guidance to the warfighter.

HERO TEST GUIDE

The *Hazards of Electromagnetic Radiation to Ordnance (HERO) Test Guide* (MIL-HDBK-240) was prepared by the services under the sponsorship of the JOCG HERO Subcommittee and provides recommended practices for conducting HERO evaluations across the service components for ordnance items and support equipment for all mission areas. There were four specific objectives of the HERO Test Guide:

1. The documentation of a HERO triservice test methodology
2. The promotion of a test standard
3. The identification of alternative techniques and identification of instrumentation
4. The facilitation of the exchange of HERO test data

It was determined that each of the service components must establish and maintain the same test philosophy and methodology in order to provide triservice guidance. This was critical because HERO test data is used to determine the MAE for ordnance and weapon systems containing EIDs and that, ultimately, MAE information is used to assess HERO risks and develop effective control measures to minimize these risks. In order to evaluate service test data in the joint environment, the guidance must translate down from a standardized test methodology (i.e., the proper test EME, evaluation of the SUT in the various stockpile-to-safe separation configurations, and knowledge of the instrumentation techniques used during testing). It followed that once standardized test methodologies were established to define the MAE, the exchange of meaningful

HERO test data could be accomplished once the operational EME was defined.

JOINT HERO CURVES AND THE MAE ANALYSIS PROGRAM TOOL

While each of the service components had established programs to evaluate ordnance and commonality for HERO testing, as established under MIL-HDBK-240, the JOCG HERO Subcommittee tasked NSWCDD to develop a computer-based software program capable of predicting the maximum response of an ordnance system's EIDs to a wide range of EMEs and translating this information into service guidance in the form of MAEs. The goal of the MAE analysis program was to provide a tool that would provide service guidance consistent with one another. In addition, the program needed to be capable of calculating the distance at which an ordnance system will remain safe and reliable from a given emitter source. Calculations were to be based on the characteristics of the transmitter/antenna system and the ordnance system's MAE for the frequency range of concern. The safe separation distance calculations needed to take into account near-field as well as the far-field EMEs.

In order to develop a common "worst-case" MAE curve or a set of curves for a given system, the HERO Subcommittee needed to understand the existing means by which each service

- Developed MAEs and HERO guidance
- Established a common set of HERO curves that would adequately address each of the service's ordnance physical configurations
- Established an accepted approach for calculating EMEs in the near-field

Prior to this effort, it was discovered that there were a wide range of "worst case" MAEs being used by each of the services. In addition, it was important to understand the factors that were considered (i.e., physical configuration, EID sensitivity, firing consequence, or stockpile-to-safe separation phase) by each of the services for the derivation of these service-unique "worst-case" graphs. Through the efforts of the JOCG HERO Subcommittee, a triservice "worst-case" graph was developed, and the MAE analysis program was completed. This tool, developed at Dahlgren, provides the service components a consistent means for establishing the minimum EME levels that will be placed on a system for which there is no information known about the item, except that it contains an EID and also provides a means of calculating EMEs in both the near-field and far-field.

JOERAD DATABASE

It was decided that the JOCG would help with the development of the JSC JOERAD database. The primary goal of JOERAD was to provide operational commanders and planners with the necessary information to safely and efficiently manage the conflict between ordnance and RF emitters employed in an integrated joint operation or exercise. Within JOERAD, there currently exist four modules:

1. The HERO ordnance module containing the HERO data from the service components
2. The equipment characteristics module containing emitter/antenna data for known systems
3. The operational unit/platform module containing emitter suites and ordnance load-outs for operational platforms

4. The impact assessment module that provides operational guidance through a process that compares the known ordnance susceptibilities to the platform EMEs

As can be seen in Figure 1, the success of JOERAD relies on the ability of the service components—particularly the Navy through its survey efforts—to populate the modules with the necessary data. The efforts of the JOCG HERO Subcommittee and the standardization of the HERO test methodology within the HERO test guide, not only allowed for the interpretation of the service components archival test data for population into the susceptibility module, but also ensured that future susceptibility data would be readily incorporated into JOERAD. The establishment of a joint uniform test criteria and a process for properly managing the service components' information facilitated the

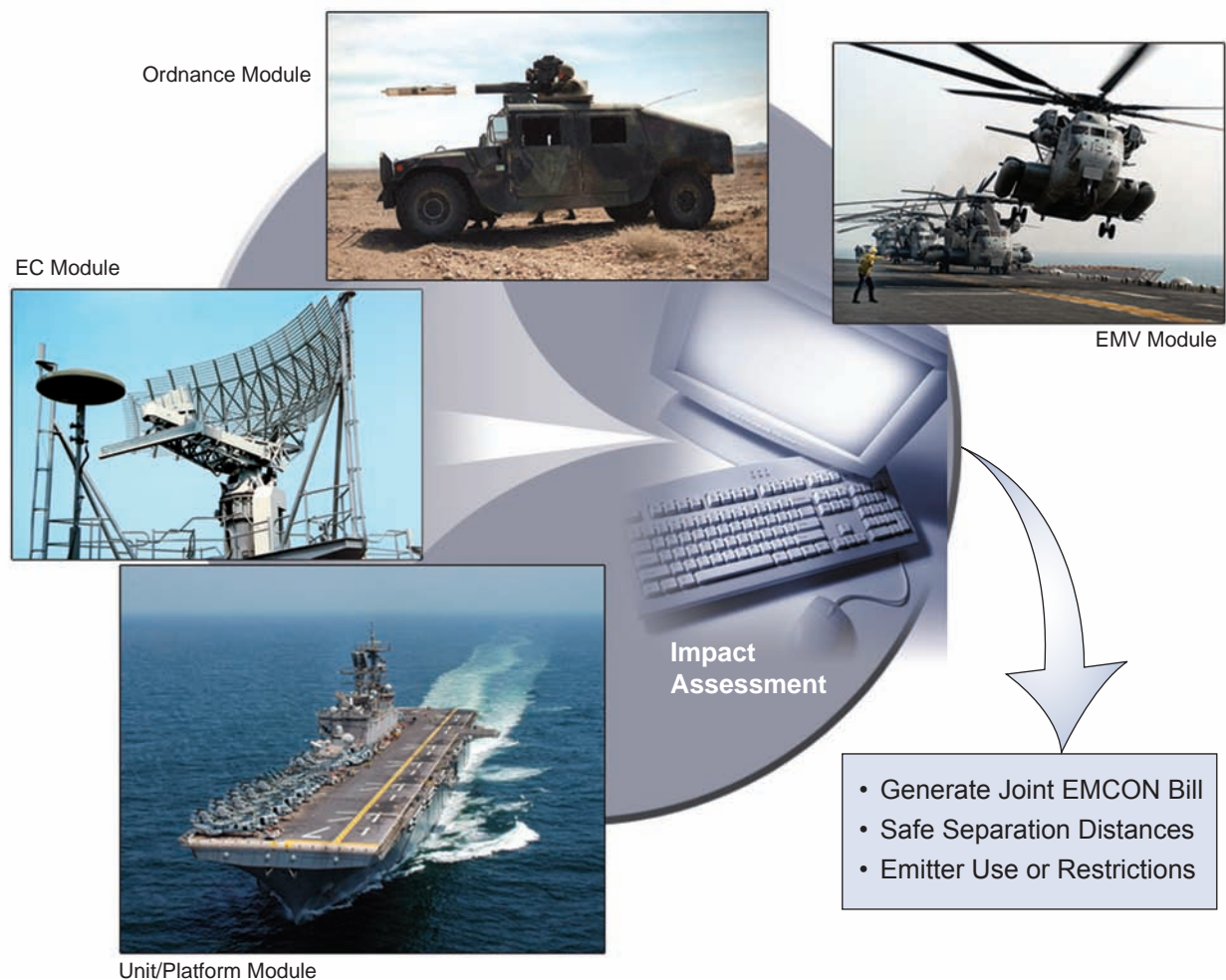

Figure 1. JOERAD Functionality



Figure 2. Integrated Operations

transfer of operational guidelines, procedures, and technical information to the warfighter for use in planning, coordinating, and controlling HERO during integrated operations and exercises in the joint environment (see Figure 2).

FORWARD-DEPLOYED SURVEYS

In recent years, the Navy's HERO survey program has increased its emphasis on joint and coalition forces' operations at the request of the JSC and NOSSA. Since the Army and Air Force have not

established HERO surveys as part of their HERO programs, the Navy has taken the lead to address joint and coalition forces' operations in theater. The survey data is also used to update the EME module in JOERAD in order to provide better joint HERO guidance. To date, NSWCCD has been responsible for planning, conducting, and reporting the findings on forward-deployed surveys, as well as for providing joint, integrated HERO guidance specific to these facilities. Some of the surveys performed include:

- NAVSUPACT in Diego Garcia
 - Prince Sultan Air Base in Saudi Arabia
 - Naval Air Station (NAS) Bahrain in Bahrain
 - NAS Sigonella in Italy
 - Korea
 - Al Dhafra Air Base in United Arab Emirates
 - Al Udeid Air Base in Qatar
 - Camp Lemonier in Djibouti
 - Manas Air Base in Kyrgyzstan
- More recently, surveys have been performed at:
- Naval Special Warfare Group at Panzer Kaserne, Germany
 - Ali Al Salem Air Base and Ahmed Al Jaber Air Base in Kuwait
 - Al Asad Air Base and Al Taqaddum Air Base, in the Anbar Province of Iraq

TRISERVICE HERO APPROACH

The strength of the Navy's HERO program, coupled with the efforts of the JOCG HERO Subcommittee, has proven to be a successful approach for dealing with more recent joint and coalition forces when operating in the joint and naval EMEs. In 2001, the Navy HERO program developed operational procedures for USS *Kitty Hawk* so that its

complement of Joint Special Operations Command (JSOC) personnel could safely embark and disembark from this platform. Since that time, in support of joint and combined operations from Diego Garcia (see Figure 3), Saudi Arabia, Iraq, and Bahrain, the Navy HERO program has provided rapid responses to urgent mission needs for joint and coalition forces regarding new radar, satellite, telemetry, mobile, and high-frequency (HF) systems that were being deployed. Additionally, multiple forward-deployed ship platforms have requested and received assistance in determining if existing HERO control measures adequately address potentially new HERO issues in the midst of joint and coalition force operations. The success of the more recent efforts described above were directly related to the strength of the Navy's HERO program and the HERO tools established through the efforts of the JOCG HERO Subcommittee. Armed with the access to, and an understanding of, all of the service component's HERO test data, planning, coordinating, and controlling HERO during these integrated joint operations has become more streamlined.

As this triservice approach to HERO continues to grow, the services and, in particular, the Navy



Figure 3. Diego Garcia Joint and Combined Operations

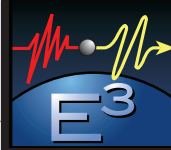

will better be able to address HERO concerns when operating with joint forces aboard naval platforms, afloat, and ashore. Furthermore, through the master data exchange agreement (DEA) programs in place with the various North Atlantic Treaty Organization (NATO) nations and the U.S. Navy's representation in the NATO Radio and Radar Radiation Hazards Working Group (RADHAZWG), the Navy HERO program has similarly improved its capabilities to deal with coalition forces present in the naval environment (see Figure 4). Not only have the international efforts allowed U.S. input to the development of NATO EME standards, but it has also helped ensure rationalization, standardization, and interoperability of U.S. forces in NATO operations.

Naval shipboard and forward-deployed ashore forces' EME is continually increasing in scope and magnitude. In light of the fact that joint integrated operations (both helicopter and ground forces) are becoming more commonplace, particularly in the naval environment, it is especially important to ensure that a triservice approach for mitigating HERO is maintained. This will ensure that the combatant commanders (COCOMs), JTF commanders, host platforms, and service components have the ability to address HERO issues from an

integrated joint perspective. Thus, it is imperative that all ordnance containing EIDs be evaluated for HERO under a standardized HERO certification test methodology using a common set of risk management procedures, and that automated tools be put in place to address HERO concerns. The operational EME must be defined through the HERO survey process, and operational guidance for missions must be clearly defined. Through its efforts in the JOCG HERO Subcommittee, NSWCCD has met these objectives and has been instrumental in developing the tools necessary to successfully provide effective HERO guidance for joint operations aboard ships and at forward-deployed bases. It has also demonstrated these capabilities in support of Operations Iraqi Freedom and Enduring Freedom. Inasmuch as joint military operations often require a careful balance of weapons, delivery platforms, and ordnance-handling procedures in the midst of an extreme EME, these tools have provided the necessary data needed by operational commanders and planners to safely and efficiently manage conflicts between ordnance and RF emitters employed in integrated joint and coalition operations.

REFERENCE

1. Department of Defense (DoD) MIL-HDBK-240, 1 November 2002.



Figure 4. UK/US Forces Complete Exercise "Constant Alliance"—UK and U.S. forces participated in the joint military exercise "Constant Alliance" off the East Coast of the United States from March 30–April 10, 2008. The exercise focused on an antiterrorist scenario and was aimed at ensuring UK and U.S. amphibious interoperability on future operations.





LOW-FREQUENCY MAGNETIC FIELD LIMITS FOR THE NAVY'S HERO PROGRAM

By Charles C. Denham

HERO THREATS WITHIN U.S. NAVY OPERATIONAL SCENARIOS



Until recently, there has been only limited interest in the hazards posed by magnetic fields, because there were no known sources of magnetic field radiation at magnitudes perceived as HERO threats within U.S. Navy operational scenarios. The need for Hazards of Electromagnetic Radiation to Ordnance (HERO) magnetic field limits is due, in part, to the expectation of very high magnetic field levels from systems currently under development for use in the naval environment. Two new sources of high magnetic field levels that have raised concerns in the Navy are the Electromagnetic Aircraft Launch System (EMALS) and the Electromagnetic Railgun. These systems are currently in various stages of development but, when fielded, are expected to generate unprecedented magnetic field levels. Figure 1 depicts USS *Gerald R. Ford* (CVN 78) which, upon completion, will be the first aircraft carrier to have an EMALS system installed. It was desirable, therefore, to develop a magnetic field limit for system and platform developers when assessing HERO risks and remedial steps to reduce the radiated magnetic fields or otherwise protect the ordnance exposed to those fields.

THE EMERGENCE OF NEW HERO CHALLENGES

HERO is a fundamental safety issue throughout the Department of Defense (DoD) and, until recently, its focus was on the electric fields (E-fields) generated by communication and radar systems. The absence of equipment capable of producing “threat-level” magnetic fields precluded the need for HERO assessments or the establishment of magnetic field limits.^a The Navy classifies its ordnance as either “HERO SAFE,” “HERO SUSCEPTIBLE,” or “HERO UNSAFE” ordnance, based on its degree of susceptibility to the defined DoD operational electromagnetic environment.^b HERO SAFE ordnance requires no specific restrictions in the operational electromagnetic environment. The latter two, however, require restrictions and are subject to the generalized E-field strength limits for HERO SUSCEPTIBLE and HERO UNSAFE ORDNANCE prescribed in Figure 2. While these curves provide limits for the E-field below 2 MHz, the left-hand portion of the curve reflects little more than a 20 dB per decade of frequency roll-off from 2 MHz, the point where the empirical HERO test data ends. Thus, historically, little regard was paid to this low portion of the spectrum (and the limits represented in the curve) due to the lack of a specific threat or source at these frequencies.

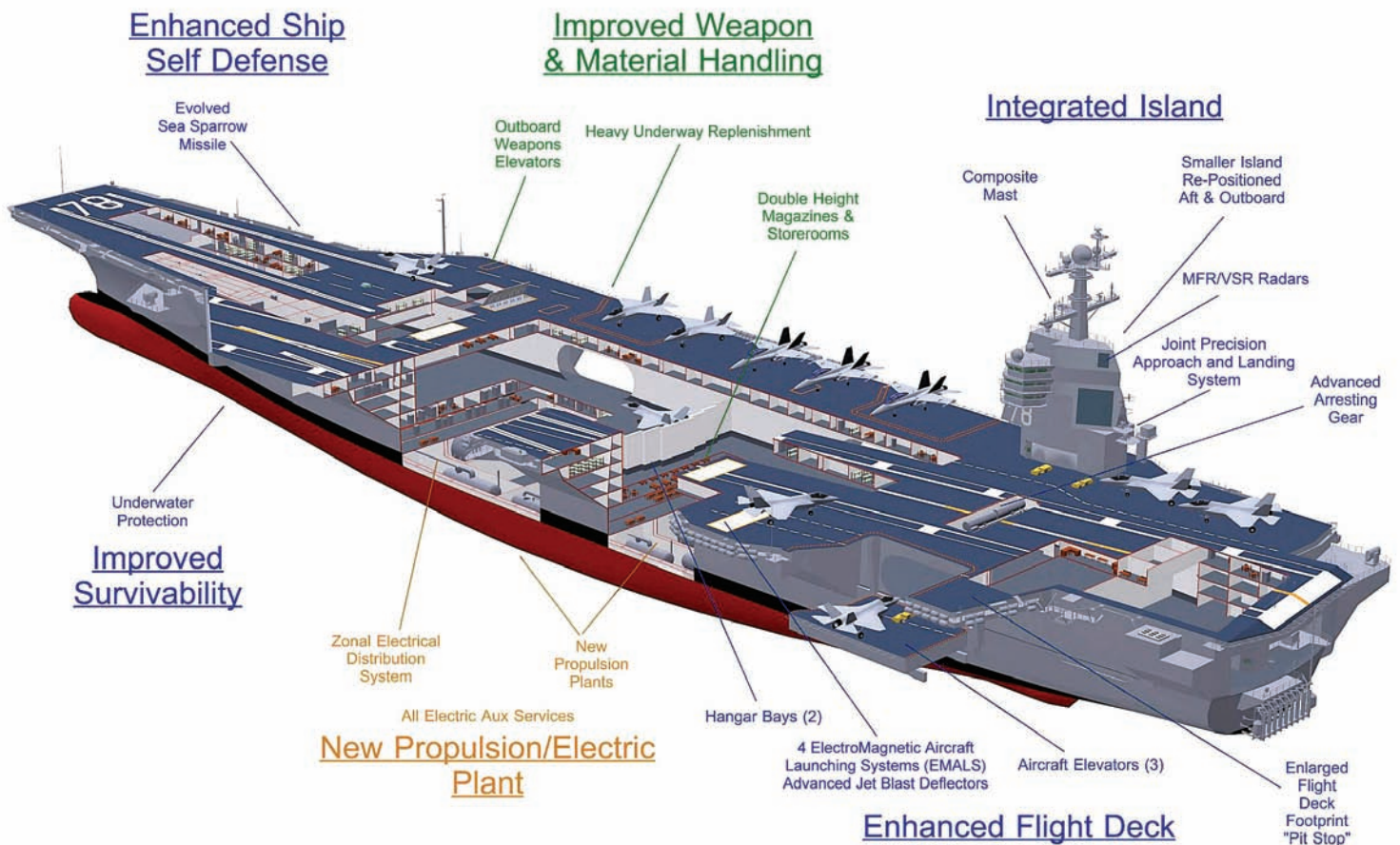

Figure 1. USS *Gerald R. Ford* (CVN 78)

As can be seen, the left-hand, theoretically based segment of the maximum allowable environment (MAE) decreases with frequency at a rate equivalent to the aforementioned 20 dB per decade. The flat region is based on empirical data from 30 years of HERO testing.

The more restrictive field limits apply to HERO UNSAFE ORDNANCE, the classification assigned to ordnance that has never been evaluated; it may be in a disassembled or test configuration, or is otherwise being subjected to unauthorized conditions or operations. In practice, HERO UNSAFE ORDNANCE is handled or stored in areas that are essentially free of radio frequency (RF) or “RF-free,” that is, where the RF environment levels are less than HERO UNSAFE ORDNANCE levels. Typically, magazines and well-shielded spaces below decks satisfy this requirement, but HERO surveys are required to confirm that this is the case. Items not in this category, but which are susceptible and require modest RF environment restrictions, are classified HERO SUSCEPTIBLE ORDNANCE. Again, HERO surveys are necessary to confirm that the E-fields do not exceed SUSCEPTIBLE levels in areas where these items are stored or handled. It can be

seen from Figure 2 that the E-field limits for HERO SUSCEPTIBLE ORDNANCE are relaxed approximately 12 dB from the HERO UNSAFE limits.

These traditional HERO terms, in addition to identifying a generic level of susceptibility in conjunction with the HERO curves, also have a very specific meaning to the sailor on a ship. As ordnance evolutions are executed, these terms allow the ship to plan for, and manage, the electromagnetic environment such that safety is maintained. Without knowing anything about specific susceptibilities for an ordnance item, the classification helps the sailor quickly identify whether or not specific steps are required to manage HERO, and what those required steps are. However, HERO guidance has historically been associated only with E-fields.

Inasmuch as the EMALS is expected to produce low-frequency magnetic fields at magnitudes that exceed existing shipboard radiation sources (e.g., communications, radar, degaussing systems), the Navy’s HERO Program has been prompted to develop new HERO limits to ensure safe ordnance operations in the presence of high magnetic fields. The effect of these unprecedented magnetic field levels, both above and below decks, is a concern

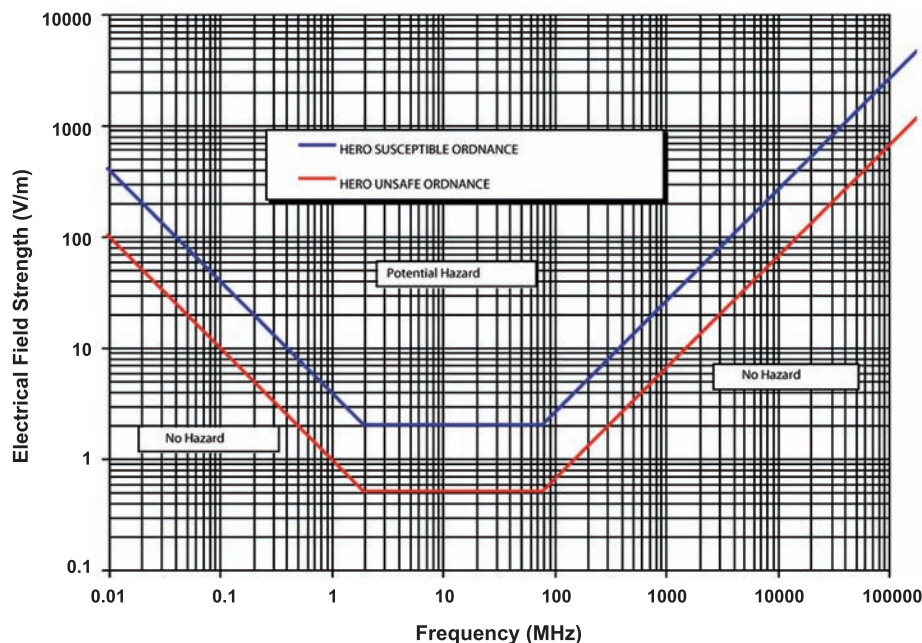
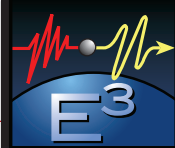

Figure 2. E-Field Limits for HERO SUSCEPTIBLE and HERO UNSAFE Ordnance

from the standpoint of potential electromagnetic interference (EMI) to electronic equipment and radiation hazards (RADHAZ); the latter concern most notably to personnel and ordnance. To develop new HERO limits, it was proposed that magnetic field limits be established in similar fashion for HERO UNSAFE ORDNANCE, as was done for the E-fields. And while this effort is still in its infancy, the development of these limits begins with a prediction of the response of HERO UNSAFE ORDNANCE to magnetic fields.

DEVELOPMENT OF MAGNETIC FIELD LIMITS

The approach taken to develop the magnetic field limit for HERO UNSAFE ORDNANCE mimicked the approach used to develop the E-field limits. Most importantly, this included conservative assumptions about the electroexplosive device (EED) sensitivity and the use of “worst-case” coupling models to calculate the voltage induced into the EED from an incident magnetic field. The EED sensitivity parameters used were the same as those used to derive the E-field limits. For E-fields, a $\lambda/2$ dipole antenna was used to model the EED firing circuit; for the case of magnetic fields, a 4.6-m^2 loop antenna was used. Here, a number of assumptions were made, including: the loop is always oriented for maximum pickup; no shielding exists from circuit leads; firing leads are not close to the ground plane; the magnetic field is homogeneous across the entire loop plane loop.

Once these important parameters were defined, the magnetic field limit was determined for each of two distinct frequency regions. The first region, for frequencies from 1 Hz to 2 MHz, was modeled by an electrically small loop. A loop area of 4.6 m^2 was chosen for two reasons: it is a practical representation of maximum firing-circuit loop areas, and this value “harmonizes” the electric and magnetic field limits. The loop area was held constant for all frequencies over which the model was used. The model was derived from Faraday’s Law and was used

to calculate the magnetic field limit based on the 4.6-m^2 loop area and electrical characteristics of a sensitive EED. For the second region, at frequencies between 2 and 30 MHz, there was no accepted model, so for a simplified approach, a constant value for the magnetic field was chosen to derive a magnetic field limit “equivalent” to the HERO UNSAFE ORDNANCE E-field limit. This amounts to deriving a magnetic field limit based on the $377\text{-}\Omega$ far-field free space impedance relationship between electric and magnetic fields.

The resulting two-segment curve is depicted in Figure 3. The limit extends only to 30 MHz because it was determined that neither the EMALS nor Railgun will produce significant magnetic field levels above that frequency. It is also expected that E-fields become the predominant concern above 30 MHz. Figure 3 illustrates the proposed magnetic field limit from 1 Hz to 30 MHz, in units of magnetic field intensity, H(A/m). This simplistically derived graph constitutes the most severe limit and is generally applicable to all ordnance.

FUTURE EFFORTS FOR LOW-FREQUENCY MAGNETIC FIELD HERO GUIDANCE

To date, the Navy’s HERO Program has developed the “proposed” worst-case, low-frequency magnetic field limit depicted in Figure 3. Still, there is much work to be done. In the near future, the Naval Surface Warfare Center (NSWC) Dahlgren plans to conduct validation testing to measure

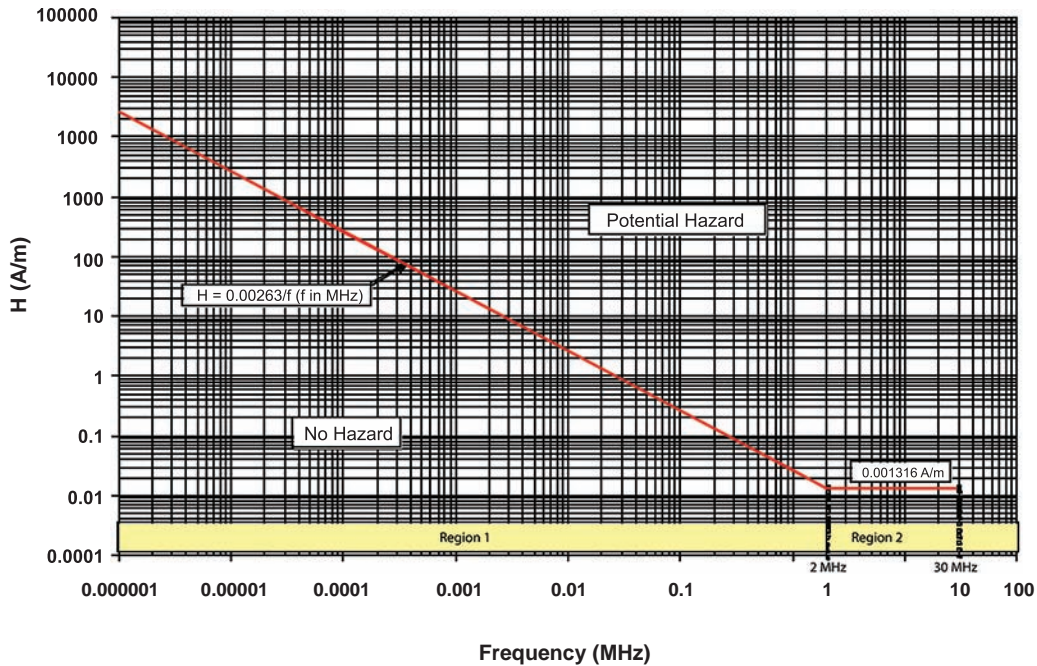

Figure 3. Proposed HERO Magnetic Field Limit (A/m)

various EED responses to various loop areas/geometries to compare measured responses to the predicted responses that form the basis of the derived field limits in Figure 3. As a result, this very conservative limit may be relaxed to a more practical level to minimize the HERO requirements during the design criteria for systems radiating low-frequency magnetic fields, as well as to reduce the level of HERO management necessary in the operational environment. Also, as was the case for the E-field limits, empirical magnetic field test data will result in the development of relaxed limits for ordnance classified as “SUSCEPTIBLE” and a new magnetic field limit curve to address HERO SUSCEPTIBLE ORDNANCE.

Once the model and the subsequent HERO limits have been established and validated, the limits will be published in NAVSEA OP 3565.¹ This data will also be incorporated into existing HERO standards to address HERO certification testing. Finally, the Navy’s HERO Program will need to address rise-time limits for transient sources, as this may prove important when systems are encountered that exceed the magnetic field limits in Figure 3, but may not impact slower-responding EEDs, thus mitigating the HERO concern. This will allow the Navy HERO Program to address ongoing concerns at the Strategic Weapons Facility, Pacific and the Strategic Weapons Facility, Atlantic with regard to weapons-handling cranes that generate transient fields. Similarly, other examples

of equipment producing severe broadband EMRs with large spectral components below 100 kHz, with a potential to create a HERO threat, are arc welders, power contactors, and weapons-handling vehicles. All of these programmatic efforts—from the defining of the magnetic field limits and addressing the transient nature of the fields to validating the models through the characterization of the actual fields and determining the sensitivity of various EEDs—will allow the Navy to adequately address HERO in the future as new systems are introduced that generate low-frequency magnetic fields of a transient nature aboard ship.

ACKNOWLEDGMENT

Mr. John Bean, EG&G Technical Services, contributed to this article.

ENDNOTES

- a. E-Field limits for HERO are identified in Figures 2-1 and 2-2 of NAVSEA OP 3565/NAVAIR 16-1-529, Volume 2, Sixteenth Revision, for HERO SUSCEPTIBLE and HERO UNSAFE ORDNANCE, respectively.
- b. E-Field HERO certification requirements are provided in Table 3A of MIL-STD-464A, *Department of Defense Interface Standard, Electromagnetic Environmental Effects Requirements for Systems*, 19 December 2002.

REFERENCE

1. NAVSEA OP 3565/NAVAIR 16-1-529, Volume 2, Sixteenth Revision.

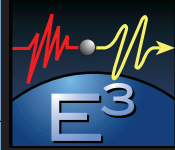

COMPUTATIONAL ELECTROMAGNETICS FOR INTEGRATED TOPSIDE DESIGN

By Gregory A. Balchin

THE TOPSIDE DESIGN CHALLENGE

Integrated topside design (ITD) is the part of the ship design process that deals with the placement, interaction, safety, and effects of weapons systems, sensors, antennas, and other equipment placed topside of the ship. ITD is a complex and challenging process. Many systems must function properly for the ship and its crew to perform their operations safely and effectively. Figure 1 shows a picture of USS *Anzio* (CG 68), which illustrates the numerous systems, including weapons systems, radars, and antennas that are topside of the ship, and includes antennas on the masts and yardarms. The ITD process must be applied to both in-service ships as well as new construction ships.

In-service ships are challenging because these ships have limited topside real estate for new systems and may already have existing performance issues with the systems already installed topside of the ship. For example, there may be issues with electromagnetic interference (EMI) among several of the topside systems. The ITD engineer for an in-service ship must find an innovative way to

place new systems on the ship—given the limited space and weight restraints—and still remain within budget. This must be accomplished without impacting the efficacy of the ship's performance.¹

ITD for new construction ships ensures that the systems planned for installation will be integrated properly in order to maximize system performance. This process continues throughout ship acquisition, beginning with concept design and continuing through the ship's life cycle. With a systems-engineering approach to ITD, new construction ships will have reduced postproduction rework, which can have a major impact on ship schedule and cost. The ITD engineer must also consider possible future issues for new construction ships so that mitigation plans can be developed.²

Areas of concern for the topside engineer include: pointing and firing cutout zones; missile and gun blast effects; structural test firing; antenna coverage and blockage; target detection range; EMI; electromagnetic compatibility (EMC); hazard of electromagnetic radiation to personnel (HERP);



Figure 1. USS *Anzio* (CG 68) Showing the Various Topside Systems That Impact Integrated Topside Design

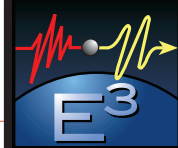

hazard of electromagnetic radiation to ordnance (HERO); hazard of electromagnetic radiation to fuel (HERF); and their appropriate radiation hazard (RADHAZ) cutout zones.³

In the past, topside design involved developing separate topside systems that were placed on the ship to optimize their performance. However, this build-and-test procedure proved too costly due to the EMI problems and subsequent in-service rework required to correct or mitigate these problems. EMI can be a major issue for systems placed topside. Interference from one system can cause the detection of false targets in another system. Blockage and radio frequency (RF) “blind spots” can also occur, which could make the ship and crew vulnerable to hostile weapons. Postproduction testing and mitigation of these issues is costly and time-consuming while keeping the ship out of service.

Today, a more cost-effective approach involves using computational electromagnetics (CEM) to model and simulate the various radar and communications antennas that are placed topside. This allows the ITD engineer to determine, prior to physical placement of a system, if there will be issues concerning EMI, blockage among different systems, or if there are possible hazards with the placement of a system. If issues are discovered, the ITD engineer can consider different placement options and mitigation procedures before installation of the system.

WHAT IS COMPUTATIONAL ELECTROMAGNETICS?

Electrodynamics is the branch of physics that deals with electric and magnetic fields, their sources, and their interactions with matter. Classical electrodynamics is completely specified by Maxwell’s equations. CEM is the branch of electrodynamics that uses various numerical techniques to solve Maxwell’s equations. The field of CEM has improved tremendously in the last decade due to advances in computer technology and the development of fast, efficient algorithms for numerical solutions of differential and integral equations (IEs).

Maxwell’s equations can be formulated either as a set of partial differential equations (PDEs) or as a set of IEs. The techniques used in CEM exploit both formulations of Maxwell’s equations and can be divided into three broad categories: full-wave methods, asymptotic methods, and hybrid methods.

Figure 2^a shows a chart of some of the various techniques used in CEM. This chart is not exhaustive. There are many numerical techniques available to the CEM engineer.

Full-wave methods involve numerical techniques that solve Maxwell’s equations rigorously and are, therefore, the most accurate of the computational categories. Asymptotic methods employ a high-frequency approximation to Maxwell’s equations. These methods provide good accuracy when used in the high-frequency region for which they are intended. Hybrid methods combine various computational techniques from full-wave methods and asymptotic methods.

Full-wave methods employ either frequency-domain (FD) techniques or time-domain (TD) techniques. Both FD and TD techniques can be formulated as a set of PDEs or as a set of IEs. Often there is a range of frequencies that are of interest for a system being modeled. TD techniques are appropriate because the system can be illuminated with a TD impulse across a wide range of frequencies. FD information is then obtained with the use of a Fourier transform. FD techniques are used to model the system at a specific frequency. These codes tend to run faster than the TD codes, and they are very good at modeling antennas at resonance.⁴ In the FD, codes that are used extensively include finite element methods (FEMs), finite difference methods (FDMs), method of moments (MoMs), and fast multipole methods (FMMs). In the TD, frequently used codes include finite difference time domain (FDTD), transmission line matrix (TLM) methods, and integral equation time-domain (IETD) methods.

Asymptotic methods are used when the physical size of the object under consideration is very large compared to the wavelength of the electromagnetic energy illuminating the object. By very large, we mean an object size on the order of tens to hundreds of times the wavelength of the electromagnetic energy. Asymptotic methods are usually divided into field methods and current methods. Many of us are familiar with ray tracing optics from our introductory physics or engineering courses. The rays trace the paths of the planar wave fronts of the electromagnetic waves that impinge on a mirror or lens. Ray tracing optics falls under geometrical optics (GO), which is a field method. In order to accurately predict the fields interacting with an object, we must also include the geometrical theory of diffraction (GTD) and its extension, the uniform theory of diffraction (UTD).

GO does not involve the calculation of currents induced on an object due to the electromagnetic fields interacting with the object. Other asymptotic methods include the calculation of the induced current on a conducting object illuminated by an electromagnetic field. The induced current is then

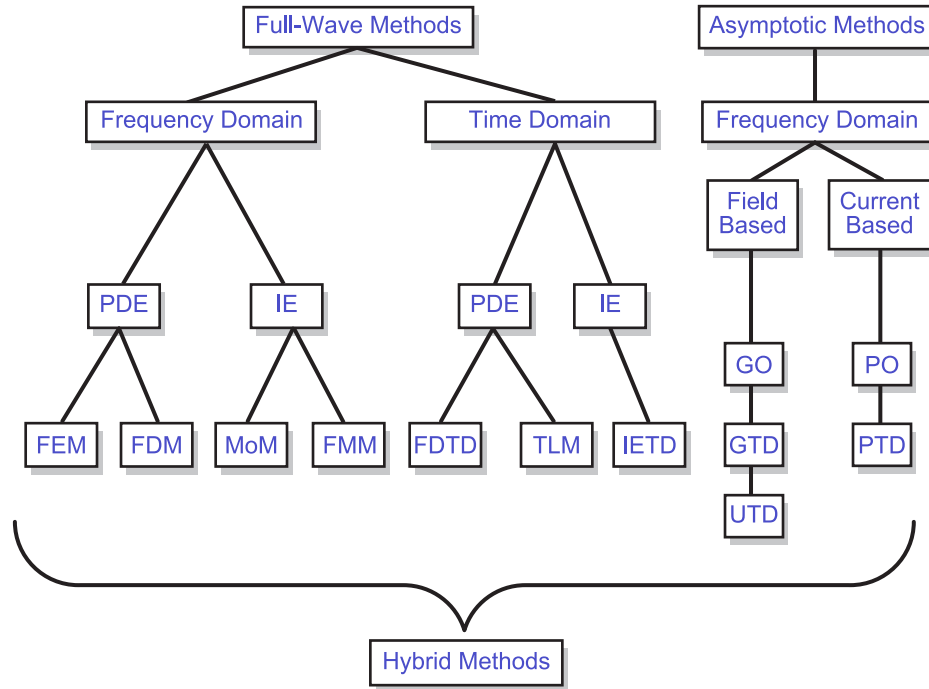

Figure 2. Various Computational Methods Used in Computational Electromagnetics

used to predict the radiated fields. Physical optics (PO) is an example of a current-based asymptotic method. PO must also be extended with the physical theory of diffraction (PTD) in order to accurately predict the fields interacting with an object.

The applicability of full-wave methods and asymptotic methods is shown in Figure 3.⁵ In Figure 3, the size of the object is given in wavelengths. Full-wave methods are appropriate when the size of the object is on the order of the wavelength of the electromagnetic energy. Full-wave methods

can be used with objects on the order of hundreds of wavelengths in length if the computer can handle the mesh constraints to minimize numerical dispersion and impacts to precision. For very large objects, the wavelength is short in comparison to the size of the object, and asymptotic methods are appropriate for that region.

Hybrid methods combine numerical techniques from full-wave methods and asymptotic methods. There are several commercial codes available that employ hybrid methods. A great deal

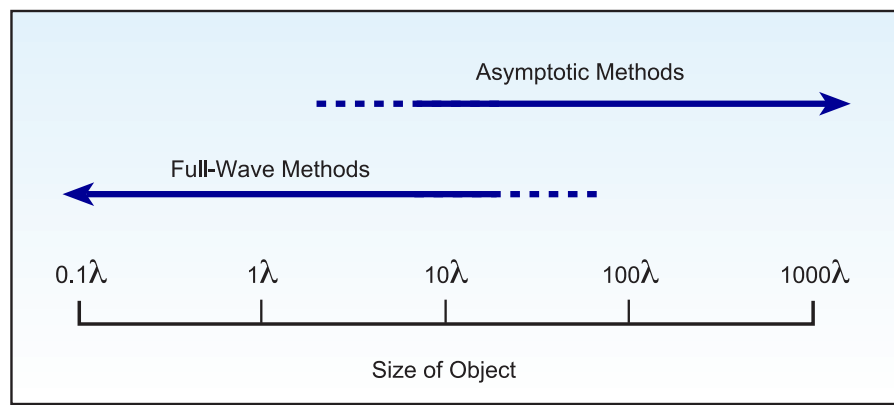

Figure 3. Range of Applicability of Methods Used in CEM

of research is currently being done in hybrid methods for Navy shipboard use because current computers still cannot handle the entire ship topside at many of the frequencies of interest. For example, in a hybrid method, a full-wave algorithm will be used to model an antenna; then the results of this model will be "handed-off" to an asymptotic algorithm to model the scattering between the antenna and other systems and shipboard structures.

The methods discussed are numerical; however, CEM also employs analytical techniques where appropriate. There are some problems in which a quasi-static approximation can be made, and the fields can be solved from Maxwell's equations analytically.

THE CEM MODELING AND SIMULATION PROCESS

The CEM process begins with the identification of possible issues (such as a proposed system placement) on an in-service ship or new construction ship. The approach is shown in Figure 4.

To help identify issues, computer-aided design (CAD) drawings of the ship are first developed. These drawings must be checked against the actual ship if it is an in-service ship to ensure the accuracy of the drawings. The drawings are updated, as required, to accurately reflect the ship. The first step in analyzing any possible issues is to apply well understood empirical methods and lessons learned to determine if the issues can be resolved using

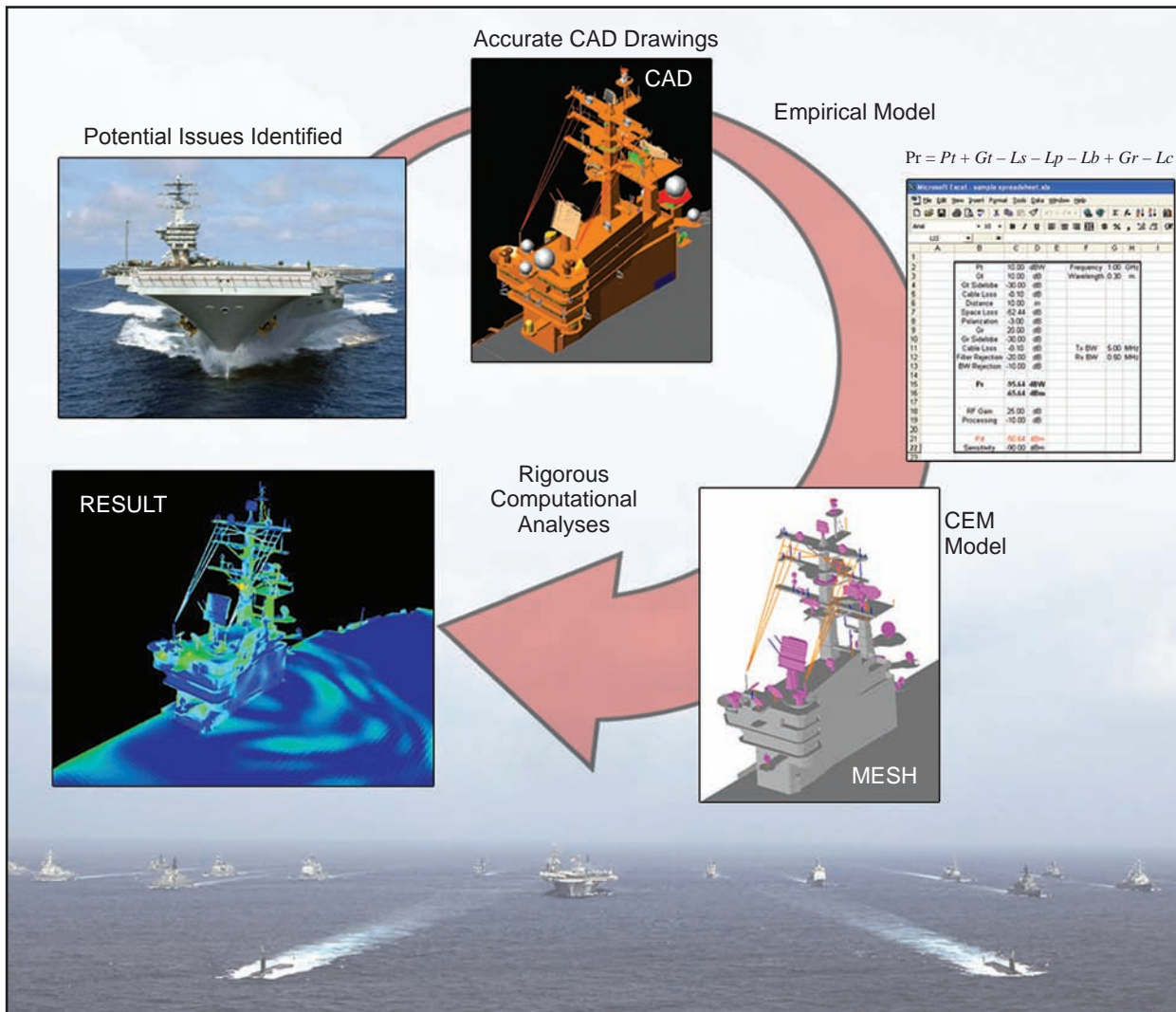

Figure 4. CEM Modeling and Simulation Process

methods from past mitigation efforts, or if further detailed modeling and analyses are required. If more analysis is required, the next step involves applying a more computationally rigorous analysis tool that provides a “quick look” at the possible issues. With each of these steps, the more difficult issues that pose the most risk to the ship are identified, and it is these high-risk issues that are subjected to the full rigor of computational analysis using state-of-the-art CEM codes and algorithms.

If more rigorous computational analysis is required, the next step is to create a model of the ship that can be incorporated into the computational electromagnetic codes. The amount of detail retained in this model depends on the frequencies of interest, the algorithm being used to solve Maxwell’s equations, and the number of mesh points required to provide an accurate solution to the problem. Other issues that impact this model include the amount of computer memory storage required and the computer run time required for convergence of the solution. Once a model has been developed, the simulation is allowed to run to achieve a result. The result often requires postprocessing to interpret the result for the topside engineer to use in making decisions concerning the placement of equipment on the ship. Depending on the issues to be solved, this CEM modeling and simulation process can take several days to several months before an appropriate result is obtained.

THE NAVY SHIP CHALLENGE FOR CEM

Systems currently installed on Navy ships range in frequency from the high-frequency band to the extremely high-frequency band. This range encompasses frequencies from below 3 MHz to approximately 50 GHz. As an example of the Navy ship challenge for CEM, consider the LPD 17, which has an overall length of approximately 200 m. The length of the LPD 17 in terms of wavelength is shown for various frequencies in Table 1.

Comparing the LPD 17 length in wavelength given in Table 1 with the ranges in Figure 3, we see that the computational electromagnetic techniques required for a typical Navy ship encompass the full range of numerical methods. At the lower frequency range, full-wave methods would be used for a particular problem. At the higher frequencies, an asymptotic method would be used.

To perform a computational electromagnetic simulation involving LPD 17, an appropriate electromagnetic model of the ship must be constructed. An example of this model is shown in Figure 5a. Next, this model must be meshed to generate cells on which the electric and magnetic fields and currents are calculated. A meshed model of the LPD 17 is shown in Figure 5b. The number of cells depends on the size of the object and the frequency of interest. For accuracy, the cell size should be $\lambda/10$ or smaller in each dimension for use with full-wave methods. The number of mesh points or unknowns for the LPD 17 is also shown in Table 1.

The number of unknowns has an impact on both the computer memory storage required for the simulation, as well as the computer run time required to arrive at a solution. For example, if a MoM algorithm is chosen for the full-wave solution, and there are N unknowns, the computer storage required is on the order of N^2 , and the time required is on the order of N^3 . As a comparison, a model using an FDTD algorithm will have M unknowns with $M > N$, but the computer storage requirements are less for the FDTD algorithm (on the order of M) than for the MoM algorithm, and the time required for the FDTD algorithm (on the order of $M^{1.67}$) is less than the time required for the MoM algorithm.

There are computer storage and time requirement trade-offs in computational electromagnetic modeling that must be taken into account. The selection of an appropriate algorithm will depend on the frequency, physical size, and computer/scheduling resources available to solve the problem.

Table 1. LPD 17 Length in Wavelengths and Mesh Points

Frequency	LPD 17 Length	Mesh Points/Unknowns
3 MHz	2 λ	50
30 MHz	20 λ	5000
300 MHz	200 λ	500,000
3 GHz	2,000 λ	50,000,000
30 GHz	20,000 λ	5,000,000,000

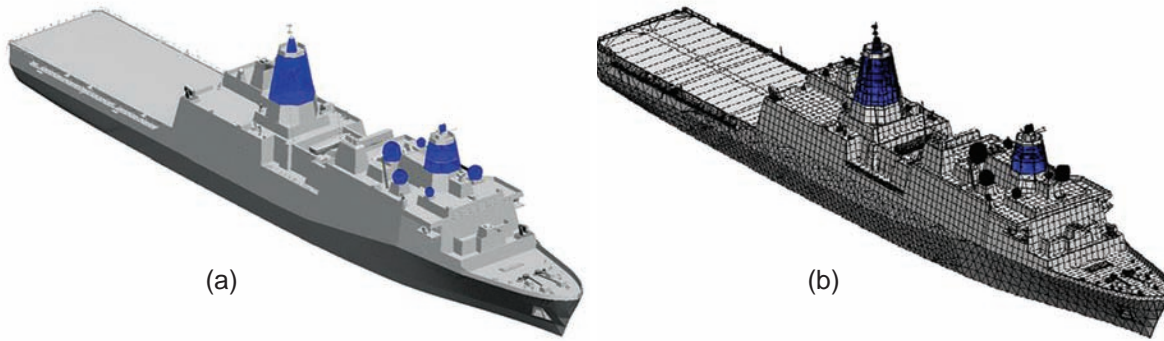

Figure 5. (a) Model of the LPD 17; (b) Mesh of the LPD 17

THE CEM GROUP AT THE NAVAL SURFACE WARFARE CENTER (NSWC) DAHLGREN

The CEM group at NSWC Dahlgren consists of five CEM analysts and two CAD experts. The CEM group has a suite of 15 desktop computers and a cluster with 13 nodes dedicated to computational analysis and CAD development. The CEM group uses both government-developed codes and commercial codes to encompass all of the numerical algorithms required to cover the range of numerical methods needed to perform CEM analysis on a

Navy ship. These codes include, for example, TLM algorithms, MoM algorithms, finite element analysis algorithms, and ray tracing and casting algorithms, as well as diffraction analysis algorithms. As part of its services, it provides CEM analysis on blockage, field patterns, coupling and EMI between systems, and field strengths for RADHAZ issues.

Often, the CEM group is asked to provide a quick analysis of possible blockage of one antenna due to another antenna or the shipboard structure. Figure 6 shows a model of an aircraft carrier island with various systems installed. The ITD

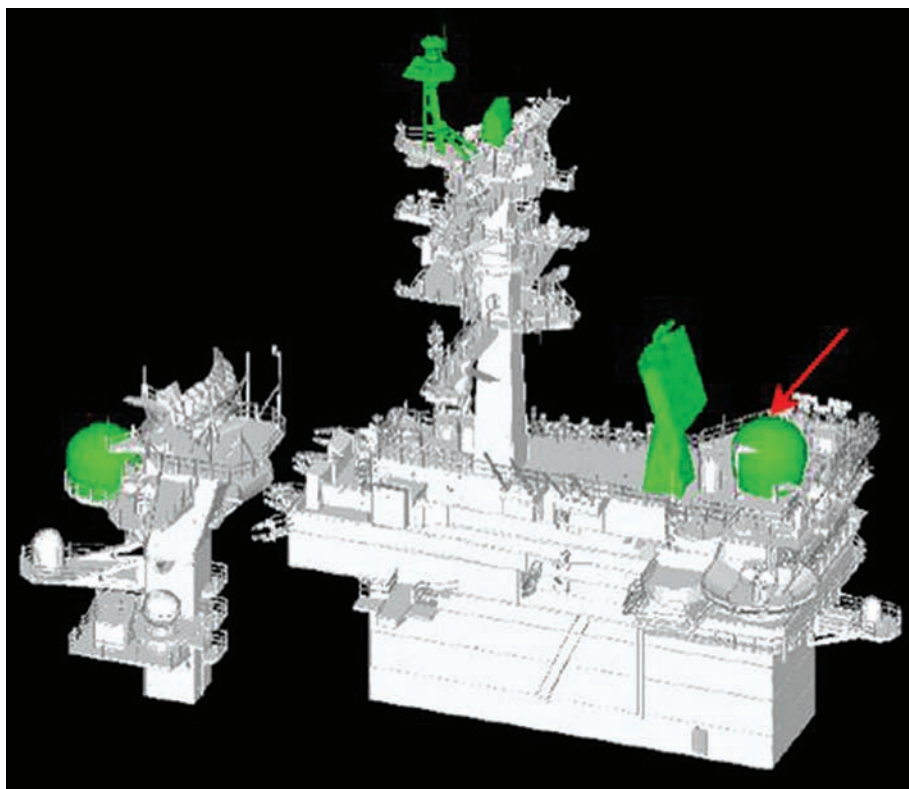

Figure 6. CEM Model for Blockage Analysis (Arrow Points to the Antenna Under Test)

engineer will want to know how blockage from other systems and structures affects what the antenna under test “sees.” The CEM group performs blockage analyses using a ray casting algorithm to determine the blockage. This is shown in Figure 7.

The blockage analysis model (BAM) optical coverage plot provides a “quick-look” line-of-sight view from the perspective of the antenna under test. This plot covers the full 360° in azimuth and below zero (horizon) to 90° (zenith) in elevation. This type of analysis is quick and provides the ITD engineer and program manager with a good estimate of the blockage of the antenna under test. The ITD engineer and program manager can see any coverage issues that the system under test may have at the chosen location.

Based on the requirements of the ITD engineer and program manager, more refined and detailed analyses may be carried out, which gives a more accurate picture of the blockage and the impact of the blockage to the RF patterns of the antenna under test. This requires the use of more rigorous computational techniques. As an example, the CEM group was asked to model the currents induced on a carrier due to a high-altitude electromagnetic pulse (HEMP). The unclassified HEMP waveform covers

a wide frequency range. Therefore, a time-based code is used because the frequency response of the ship can be analyzed through a Fourier transform of the time response, providing a wide range of frequencies. The full-wave software used to perform this analysis employed a TLM algorithm. A plane wave was used to simulate the HEMP impinging on the ship.

Because of the computer storage requirements based on the number of mesh points, the entire carrier could be modeled only up to 30 MHz. However, the carrier island, because of its smaller size compared to the ship, could be modeled up to 100 MHz. Figure 8 shows the model of the carrier island and part of the deck.

The resultant current on the island at one instant in time due to the HEMP is shown in Figure 9. The HEMP is traveling from port to starboard in the figure. The induced currents due to reflected RF energy from the island can be seen in the deck of the carrier.

The CEM group also provides CAD services for ITD. This involves performing ship checks to develop models of ships and antennas. These CAD models are used for future installations of systems and CEM analyses. The CAD services include providing the ITD engineer with alternate views of

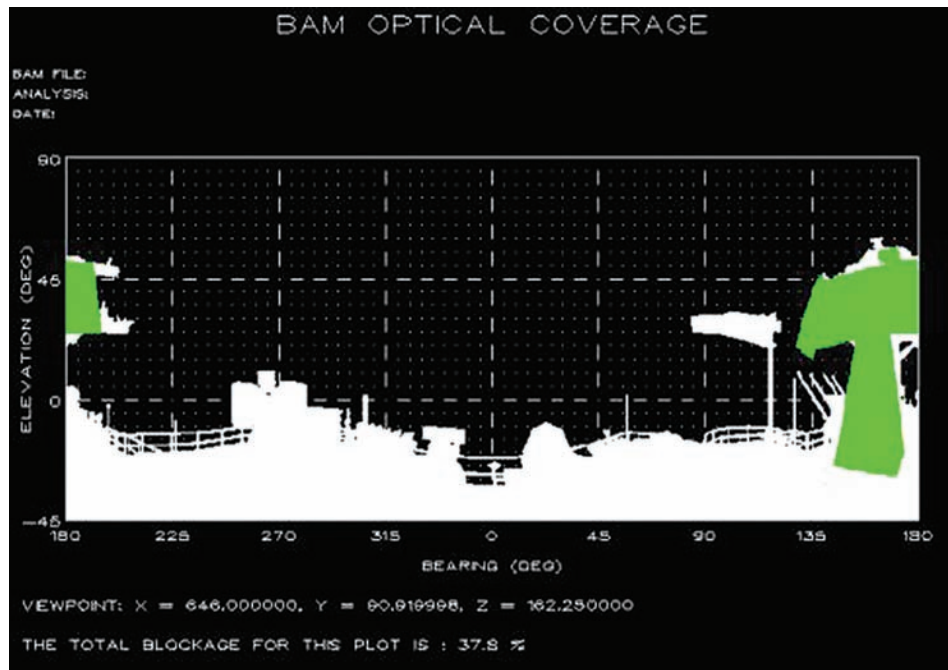

Figure 7. Blockage Analysis Model (BAM) for the Antenna Under Test in Figure 6



Figure 8. Model of an Aircraft Carrier Island and Deck

system location prior to physical placement and 2-D drawings, as requested by the ITD engineer, as well as the CAD basis for most of the numerical modeling. Other CAD services include serving as a repository of ship drawings in order to maintain and update the drawings as required.

Future CAD services will provide 3-D photo-realistic renderings of ships and ship systems, as well as animations to provide the program manager and engineer with “fly-bys” and “walk-throughs” of the ship.

Although the main service of the CEM group is to help the ITD engineer solve issues with EMI for topside systems, the CEM group also provides computational electromagnetic modeling and simulation services to other organizations and services, such as the Office of Naval Research (ONR), the Marine Corps, and the Coast Guard.

Future CEM work at Dahlgren will involve analysis of large phased-array apertures to include element-to-element coupling, coplanar coupling, and array edge effects. Members of the CEM group interact closely with the Naval Research Laboratory (NRL) and several professional CEM organizations to keep abreast of the latest code and algorithm developments.

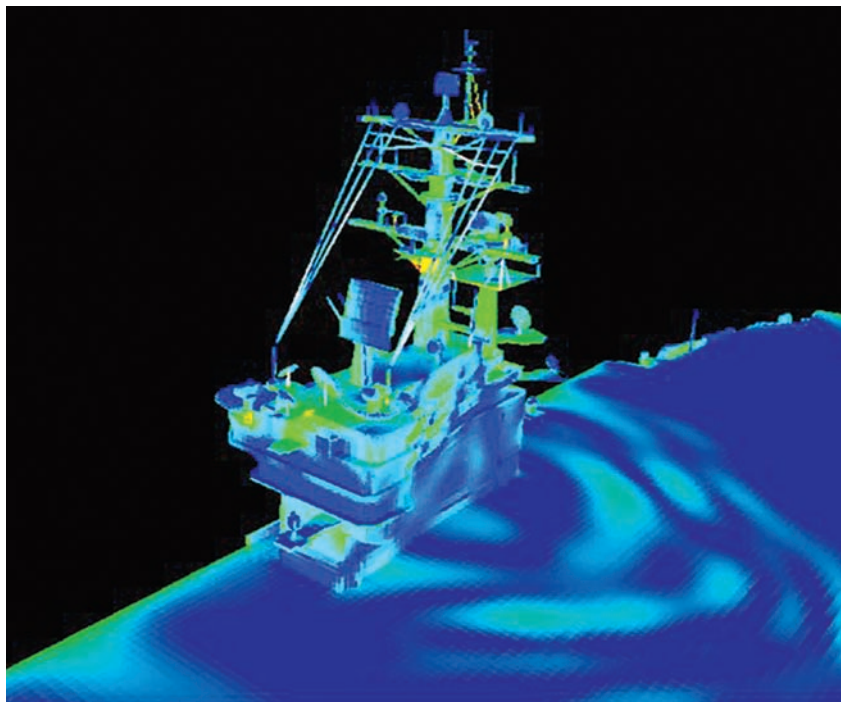

Figure 9. Induced Currents on an Aircraft Carrier Island and Deck

ENDNOTE

a. This figure is based on a similar figure on p. 428 of Reference 5.

REFERENCES

1. E3 Ship Integration, NSWCDD Q53, *Integrated Topside Design and Certification Process for In-Service Ships*, 24 April 2006.
2. E3 Ship Integration, NSWCDD Q53, *Integrated Topside Design and Certification Process for New Construction Ships*, 10 May 2007.
3. NAVSEAINST 9700.2, *Integrated Topside Safety and Certification Program for Surface Ships*, 11 September 1998.
4. Archambeault, B., C. Brench, and O. M. Ramahi, *EMI/EMC Computational Modeling Handbook*, 2nd edition, Kluwer Academic Publishers, Boston, 2001.
5. Stutzman, W. L. and G. A. Thiele, *Antenna Theory and Design*, 2nd edition, Wiley, New York, p. 428, 1998.





USN INTEGRATED TOPSIDE DESIGN

By Mark Silva

Electromagnetic environmental effects (E3) and spectrum issues impact virtually every Navy acquisition program, as well as all fleet and shore activities. Naval Surface Warfare Center (NSWC) Dahlgren's E3 Ship Integration Branch, which includes the Integrated Topside Design (ITD), Total Ship Electromagnetic Environmental Effects (TSE3), and Computational Electromagnetics groups provides up-front engineering for both new construction ships and new system installations aboard in-service ships. The ability of fleet and shore commands to successfully perform their missions without degradation due to electromagnetic interference (EMI) is a direct result of the team's efforts.

ITD is the up-front, systems-engineering-centric design process that manages the coordination of all surface ship systems and components exposed to the external environment into a functioning unit to meet all mission requirements. ITD delivers total, ship-driven, responsive, objective, and in-depth scientific and engineering solutions to ensure fleet mission success in the operational electromagnetic environment. The ITD team incorporates all topside structures, associated equipment, and cooperating elements as a total ship topside system, ensuring operability, interoperability, and survivability, while reducing installation problems and unintended impacts to ship operations and safety.

As a key contributor to the Electromagnetic Mission Assurance Center (EMAC), located at Dahlgren, the ITD team directs ship design to maximize system performance for new ships and ship alterations. The team employs the systems engineering process during the acquisition or improvement of a platform, system, or associated equipment to provide an optimized system of systems that seeks to ensure that electromagnetic compatibility (EMC) is achieved. In this capacity, the team's technical engineering products and services enhance the fleet's readiness posture.

As the Navy's engineering agent (EA) for ITD and TSE3, technical warrant holders (TWH) SEA 05D3 and SEA 05W43, respectively, the ITD team conducts analyses of shipboard topside designs, candidate equipment, and system locations to determine optimal placement of equipment and structures. These analyses support new ship design and construction, scheduled ship overhaul or upgrade periods, rapid deployment capabilities (RDC), and new system integration to meet evolving mission needs. Work efforts include all surface classes (see Figures 1 and 2): carriers, combatants, amphibious warfare ships, and ships. Future design work includes programs such as:

- Littoral Combat Ship (LCS)
- Cruiser (CG(X))

- Aircraft Carrier (CVN 21)
- Destroyer (DDG 1000)
- Amphibious Assault Ship (LHA 6 & LHA 7)
- Joint High Speed Vessel (JHSV)
- U.S. Coast Guard's Deepwater Program, including:
 - ◆ National Security Cutter (NSC)
 - ◆ Offshore Patrol Cutter (OPC)
 - ◆ Fast Response Cutter (FRC)

TOPSIDE DESIGN PROCESS

The goal of the topside designer is to maximize overall ship performance in meeting mission requirements. Teams of naval architects, marine engineers (mechanical and electrical), combat system engineers, physicists, computer modelers and ship integrators work in concert to accomplish this goal. Members of this team incorporate various stakeholders to include:

- Naval Sea Systems Command (NAVSEA)
- Space and Warfare Systems Command (SPAWAR)
- Naval Air Systems Command (NAVAIR)

- Program executive offices (PEOs)
- U.S. Marine Corps
- Ship program managers
- Ship design managers
- Planning yard
- Radar Cross Section (SEA 05T)
- Shock and Vibration (SEA 05P)

Priority is given to locating primary, secondary, and tertiary mission-related elements, followed by:

- Ship-defense
- Communications
- Navigation
- Deck operating envelopes
- Other competing weapons or sensors
- Underway replenishment
- Mast
- Other systems

Ship constraints include:

- Superstructure
- Propulsion intake and uptake stacks
- Cranes and boats
- Flight deck operating envelopes



Figure 1. USCGC *Bertholf* (WMSL 750): Newest Surface Combatant to Join the USCG

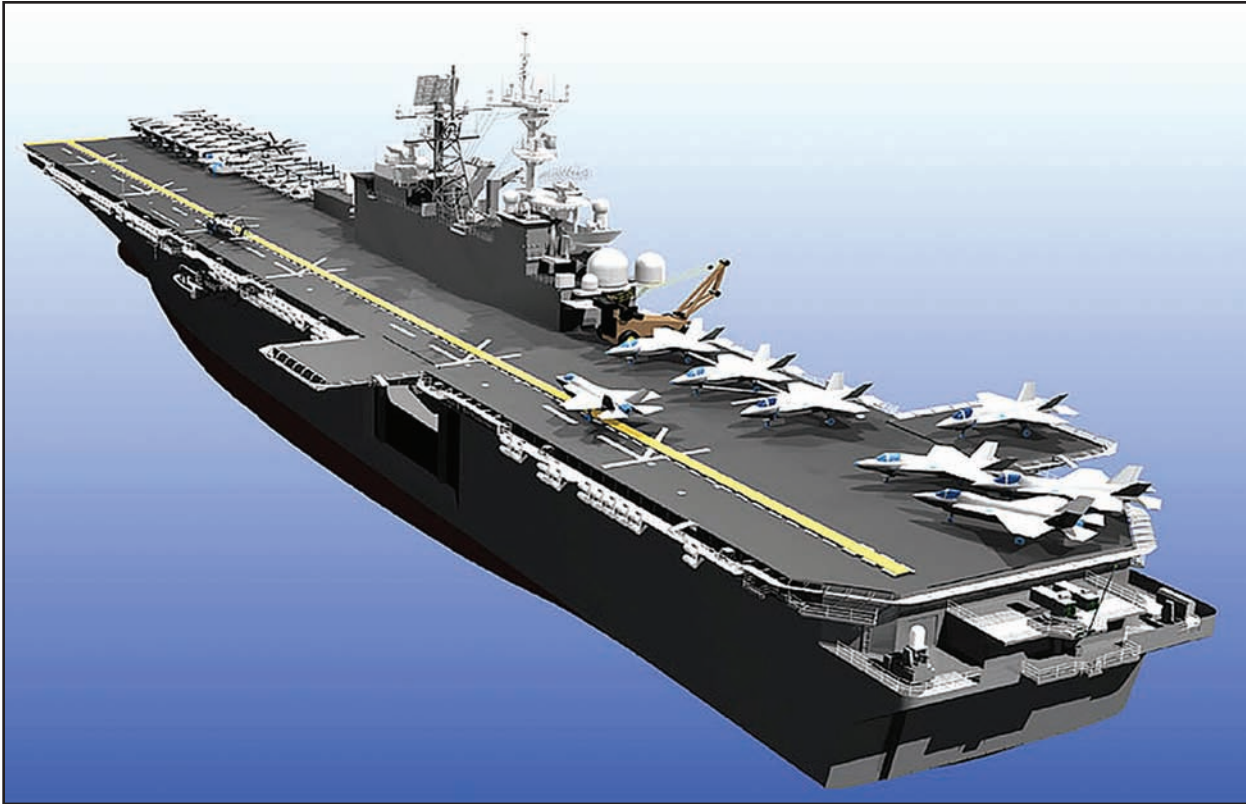

Figure 2. LHA 6 Conceptual Design to Support Joint Services Air Operations

- Other competing weapons or sensors
- Underway replenishment
- Mast height
- Panama Canal width restrictions

After placing the topside elements, the team assesses the individual performance of each system and the performance of the entire ship (see Figure 3). The team typically executes several design iterations to arrive at an optimized ship design.

INTEGRATED TOPSIDE DESIGN

In addition to enhancing sensor and weapons coverage and performance, new ship designs increasingly require an ITD to achieve the performance necessary to reduce ship vulnerability. In the past, equipment design was done independently of the topside design. The systems undergoing integration were mostly stand-alone systems, and a repeatable, standardized integration process was lacking or usually occurred late in the acquisition

process. Near the end of the last century, the Navy recognized that such an approach was no longer adequate because newer, more powerful systems were coming to the fleet, and future performance requirements were increasingly more challenging (see Figure 4).

Consequently, the EMAC topside design team is increasingly involved with new equipment acquisition programs to ensure that crucial ship integration design aspects are addressed. New programs such as the Commercial Broadband Satellite Program (CBSP), the Mk 38 Mod 2 Machine Gun System, and the Enhanced Manpack Ultrahigh Frequency (UHF) Terminal (EMUT) are being matured utilizing a concurrent engineering approach that has involved all the technology stakeholders early on to provide quality solutions that, in turn, enhance the sailors' and Marines' capabilities to engage enemies, assure victory, and return safely to home port.

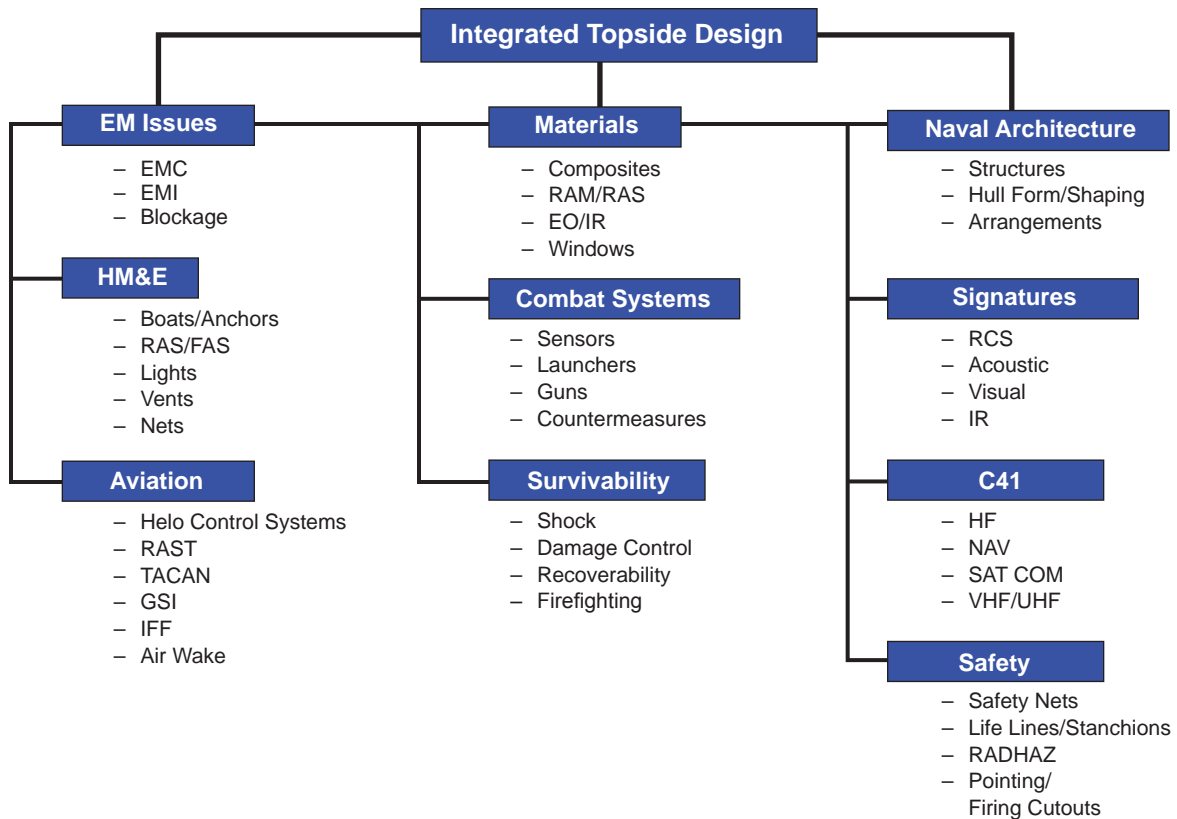

Figure 3. Topside Design Incorporates Multiple Disciplines

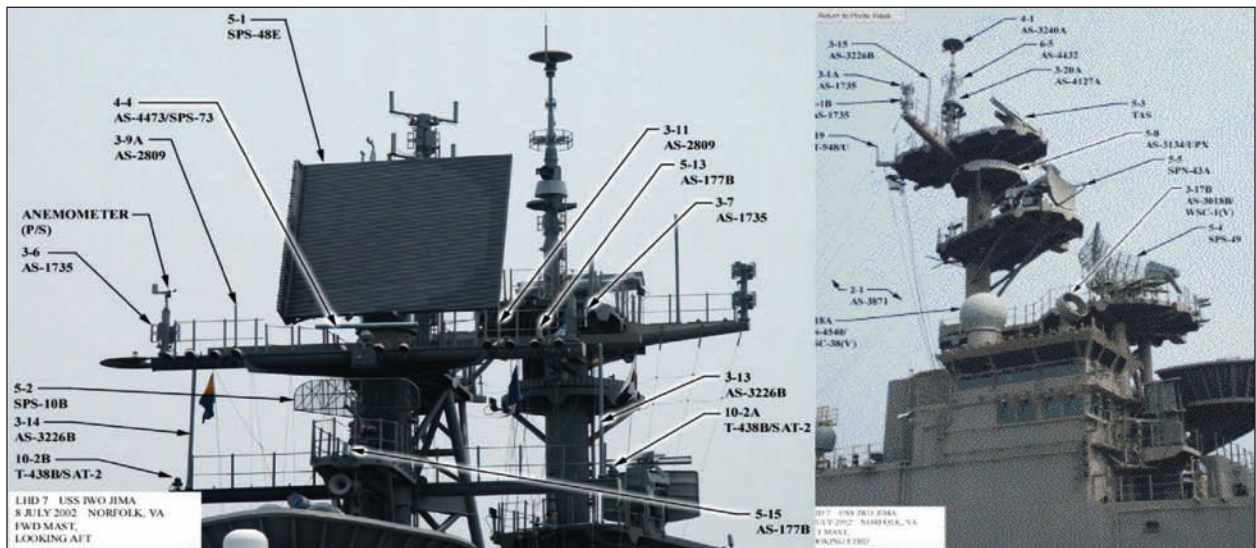

Figure 4. Numerous antennas competing for limited space and coverage result in a complex electromagnetic environment (EME), presenting a challenge for effective topside integration and maintaining the topside baseline.

SUPPORT TO HURRICANE KATRINA DISASTER RELIEF OPERATIONS

By Margaret Neel



When Category 5 Hurricane Katrina pounded the Southeastern United States in August 2005 (see Figure 1), it caused unbelievable devastation to the region. It also caused tremendous problems for first responders; federal, state, and local departments and agencies; and the Navy, who were all supporting Federal Emergency Management Agency (FEMA) disaster relief operations.

Many people know firsthand the impact of a natural disaster. Something many people may not fully understand, however, is that underlying successful rescue and relief efforts is an invisible force called the electromagnetic spectrum—the medium that transports cellular phone calls, distress signals, and air traffic control commands. The Naval Surface Warfare Center, Dahlgren Division (NSWCDD), through its Electromagnetic and Sensor Systems Department, E3 Force Level Interoperability Branch, Spectrum Engineering Group, supported Hurricane Katrina operations and played a key role

in coordinating and controlling the electromagnetic spectrum during those operations.

To do so, it employed the Spectrum Engineering Group's software program called the Afloat Electromagnetic Spectrum Operations Program (AESOP), which sailors routinely use to develop frequency plans for radars, communications, and weapon systems prior to every underway period anywhere in the world. Inherent to the AESOP software is the engineering expertise of the AESOP Team to identify, measure, and quantify electromagnetic interference (EMI) and to develop the AESOP software models that provide actionable results in real-world situations. Without proper AESOP analysis and frequency plans, the U.S. Navy risks system fratricide and the violation of international spectrum law.

In support of the Hurricane Katrina relief efforts, at a time when most normal communications systems and infrastructure had been wiped out by

A satellite image of Hurricane Katrina over the Gulf of Mexico. The storm is a large, circular system with a distinct eye and a dense, swirling cloud structure. The surrounding ocean is dark blue, and the landmasses of the Gulf Coast are visible in shades of green and brown. The image is taken from a high angle, showing the full extent of the storm's cloud cover.

Figure 1. 050828-O-0000X-001 Gulf of Mexico (August 28, 2005)—GOES-12 Satellite image provided by NASA Goddard, Space Flight Center, Maryland, showing the status of Hurricane Katrina, at 1200Z or 7 a.m., EST. The storm crossed South Florida Thursday and headed back to sea in the Gulf of Mexico. The storm's wind has now increased to 160 mph, a Category 5 storm. Only three Category 5 hurricanes—the highest on the Saffir-Simpson scale—have hit the United States since record keeping began. The last was 1992's Hurricane Andrew, which leveled parts of South Florida, killed 43 people, and caused \$31 billion in damage. The other two were the 1935 Labor Day hurricane that hit the Florida Keys and killed 600 people, and Hurricane Camille, which devastated the Mississippi coast in 1969, killing 256. Katrina was over the Gulf of Mexico, about 250 miles south-southeast of the mouth of the Mississippi river at 7 a.m. local time, according to an advisory posted on the U.S. National Hurricane Center's website. The storm was moving toward the west-northwest at 12 mph. NASA photo (RELEASED)

the force of the hurricane and the flooding from Lake Pontchartrain, members of the Spectrum Engineering Group's AESOP team provided both on-site and long-distance support to ensure proper spectrum coordination. AESOP team members were on-site at the Joint Task Force (JTF) Katrina Spectrum Management Element (JSME), which was headquartered in Norfolk, Virginia. They coordinated spectrum use for U.S. Navy ships and U.S. Coast Guard vessels, in conjunction with the National Guard; FEMA; and other federal, state, and local authorities. That was a huge task, involving frequency requirements for several hundred frequency-dependent devices that were very quickly moving in and out of the area. The task was further exacerbated by the fact that there was no estimation of how many of the land-based relay towers or other infrastructure for communications systems were still intact and operational (see Figure 2).

The Navy deployed 19 U.S. Navy ships to the area to provide rescue support. Three of the U.S. Navy ships—USS *Bataan*, USS *Iwo Jima*, and

USS *Shreveport*—provided hospital beds to augment the field hospitals established at Louis Armstrong New Orleans International Airport. At least 346 helicopters and 68 airplanes supported the operation and ferried injured civilians to the ships (see Figure 3). None of this could have been accomplished without access to and proper coordination of the electromagnetic spectrum. From communications, to air traffic control, to navigation, hundreds of spectrum-dependent devices were brought into action to support military and civilian operations.

Early in the Hurricane Katrina rescue effort, the on-site AESOP team identified some problems that could have severely curtailed the Navy's ability to provide support to the rescue operation. Two of the more serious problems included a lack of Navy systems' frequency assignments for the Gulf of Mexico area and invalid Defense Department Form 1494 (DD-1494) data for some equipment.

In the same way that you may have seen television public announcements for renewal of a broadcasting license, military equipment also must be



Figure 2. 050903-N-6046R-007 Fort Worth, Texas (September 3, 2005)—U.S. Navy Commander Paul Widish, assigned as Operation Officer of Naval Air Station Joint Reserve Base (JRB) New Orleans, communicates with rescue operation personnel from the base's Emergency Operations Center. The Navy's involvement in the Hurricane Katrina humanitarian assistance operations is led by the FEMA, in conjunction with the Department of Defense. U.S. Navy photo by Photographer's Mate 1st Class Andrew Rutigliano (RELEASED)

granted approval to operate in a given geographic area. In the Gulf of Mexico, at the time of Hurricane Katrina, most of the frequency assignments for Navy equipment had expired. Consequently, from a legal standpoint, the U.S. Navy could not turn on any system that radiated electromagnetic energy that did not have an approved frequency in that area. U.S. Navy ships had a mission to complete, however, and needed a way to solve this problem and save human lives. To address this situation, the AESOP team prepared and submitted to the Area Frequency Coordinator's office, the Navy-Marine Corps Spectrum Office, and the JTF Katrina staff, several requests for special temporary frequency assignments for mission-critical systems. Following this process ensured that the Navy's frequency use was properly logged with the appropriate commands so that those frequencies would be protected and could be legally used to support mission-critical operations.

The second major problem involved outdated DD-1494 forms for some Navy equipment. Some of the requests that the AESOP team submitted for temporary frequencies could not be resolved against the official DD-1494 records for the systems' characteristics, such as emission bandwidth, transmitter power, receiver sensitivity, and antenna gain, to name a few. Consequently, the AESOP team immediately initiated an effort to update the DD-1494 forms for those systems. Updates to several radars have been completed and processed through national databases that track and regulate spectrum use.

Hurricane Katrina represented just one example of how the AESOP team helps to assure Navy missions. Without the AESOP team's support, and without the AESOP program, the Navy might not have been able to fulfill its disaster relief mission and the situation, as bad as it was, could have been exponentially worse.



Figure 3. 050901-N-8047K-158 Mississippi (September 1, 2005)—U.S. Navy air crewmen, assigned to Helicopter Support Unit Pensacola, survey the damage from hurricane Katrina en route to Stennis Space Center, Mississippi, after leaving Naval Air Station Pensacola, Florida, to provide support and relief to victims of the hurricane. The Navy's involvement in the humanitarian assistance operations is led by FEMA, in conjunction with the Department of Defense. U.S. Navy photo by Mr. Larry W. Kachelhofer (RELEASED)

E3 SUPPORT OF COUNTER REMOTE-IED ELECTRONIC WARFARE

By Kenneth D. Larsen, D. Michael Mearns, and Albert H. Pitts



THE IMPROVISED EXPLOSIVE DEVICE

September 11, 2001, is a day cemented in the minds of Americans. Al Qaeda's attacks on that day initiated what became known as the global war on terror. Seven years later, with U.S. and coalition forces still fighting in Iraq and Afghanistan, thousands of American and coalition forces have died, many as a result of improvised explosive devices (IEDs). Unconventional? Yes. Effective? Unsettlingly so. IEDs clearly took center stage in Iraq, replacing traditional warfare (see Figure 1). They were initially used on a small scale during the Vietnam War and again in Afghanistan years later. However, since the United States' 2003 invasion of Iraq, the popularity of IEDs among Al Qaeda terrorists has greatly increased.

Today, the challenge facing the electromagnetic environmental effects (E3) community centers on remote-controlled improvised explosive devices (RCIED). The question being asked is: How do we maintain the effectiveness of devices designed to counter RCIEDs, while ensuring electromagnetic compatibility (EMC) with other radio frequency (RF) systems that warfighters need? For the U.S. Navy E3 community, this is not unfamiliar territory. Since RF systems were first fielded on ships, the Navy has been confronted with electromagnetic interference (EMI) challenges. To address these challenges, the U.S. Navy stood up programs and assigned them



Figure 1. Result of IED Attack—NSWCDD Reservist in Convoy

the task of improving EMC among ship systems and families of systems. Two such programs are:

1. The Shipboard Electromagnetic Compatibility Improvement Program (SEMCIP), which concerns itself with surface ships and submarines
2. The Air Systems Electromagnetic Interference Correction Action Program (ASEMICAP), which concerns itself with issues related to aircraft

In Iraq and Afghanistan, while the platform focus changed from ships to ground-based vehicles, and while the systems differ from those traditionally observed on Navy platforms, the problem remains essentially the same: large numbers of emitters on limited real estate. To the EMI problem solver, the ground vehicle challenge, therefore, represented nothing more than a ship on wheels.

Over the years, U.S. ground forces witnessed an ever-increasing number of RF transmitters and receivers on ground vehicles. The traditional paradigm of EMC through system separation proved ineffective. Thus, the lingering challenge remained: how do we optimize performance and ensure EMC with the constraint of limited real estate? This is a familiar challenge for the Navy. In accepting this challenge, the Navy E3 community

expanded its EMC role to assist the other services and coalition ground forces supporting the global war on terrorism in both the Afghanistan and Iraq theaters.

The Naval Surface Warfare Center (NSWC) (Dahlgren Division (DD) and Crane Division (CD))—in concert with the Naval Explosive Ordnance Disposal Technical Division (NAVEOD-TECHDIV), U.S. Army Intelligence & Information Warfare Directorate (I2WD), and other agencies—supported the design, development, and fielding of mounted and dismounted counter remote IED electronic warfare (CREW) systems for Program Executive Office, Littoral Mine Warfare (PEO LMW), PMS-408 (PMS-EOD/CREW), and the Joint IED Defeat Organization. Faced with a compressed fielding plan, the tasks were daunting and included such things as system assessments, system effectiveness testing, RF hazard assessments, spectrum management, and EMI problem solving.

EFFORTS IN SUPPORT OF CREW

System Assessment

The Naval Surface Warfare Centers were assigned the responsibility of conducting system assessments on each CREW systems design and to

participate on the source selection boards as subject matter experts. During the source selection process, E3 engineers assessed each competing CREW system's graphical user interface (GUI), functional block diagram, firmware design, RF architecture, and overall system capabilities. Effectiveness, compatibility, and interoperability tests and test results were summarized and explained to the board members. Competition test results, field reports from theater, and inputs from NAVEOD-TECHDIV, NSWCCD, NSWCCD, Naval Research Laboratory (NRL), Johns Hopkins University Applied Physics Laboratory (JHU/APL), and I2WD were used to shape future system requirements and testing for new systems and for subsystem components. E3 engineers helped shape future system requirements and subsequently performed subsystem component testing during system development, as well as complete systems testing during CREW system competitions or legacy system updates.

System Testing

The Naval Surface Warfare Centers supported system testing in order to quantify each CREW system's ability to defeat an IED. Compatibility tests determined the extent to which non-CREW systems deployed in support of the warfighter could operate simultaneously near a CREW system. These types of tests required detailed electrical knowledge of the IED, how it was employed, CREW system functions, and operational tactics to accurately determine how well a CREW system could defeat an IED. Compatibility tests determined whether two different CREW systems operating simultaneously could suppress an IED without destructive interference. Furthermore, engineers helped determine safe operating procedures to prevent any operationally destructive effects among CREW systems while suppressing an IED. Compatibility testing determined how various non-CREW systems and CREW systems could operate simultaneously on the same vehicle. Knowledge of CREW and non-CREW systems' operational parameters were used to test various scenarios to determine family-of-systems capabilities and limitations. Based on the effectiveness and compatibility test results, tactics were developed to best optimize each type of CREW system's capabilities.

RF Hazards Assessment

NSWCDD's E3 Assessment and Test Branch of NSWCCD conducted hazards of electromagnetic radiation to ordnance, personnel, and fuel (HERO,

HERP, and HERF) testing before and after effectiveness. They also conducted compatibility testing to determine if the systems were safe to operate and to determine the safe standoff distances from each CREW systems antenna. The branch conducted a number of HERO tests on a variety of U.S. Marine Corps, U.S. Navy EOD, Army, and Air Force mine resistant ambush protected (MRAP) platforms and other vehicles. As a result, HERO guidance, in the form of safe separation distances, was identified, and this information was promulgated to forces deployed in theater to mitigate the possibility of inadvertent initiation of ordnance in the proximity of vehicular transmitting systems, including CREW. In addition, HERP and HERF testing was accomplished on these vehicles to identify radiation hazard (RADHAZ) concerns, and control measures were subsequently provided to mitigate and manage these concerns. Similar specific absorption rate (SAR) testing was also performed on man-portable CREW systems.

Spectrum Management

NSWCDD's E3 Force Level Interoperability Branch leveraged established infrastructure to provide spectrum management and deconfliction. The Afloat Electromagnetic Spectrum Operations Program (AESOP), originally developed for NAVSEA 62E, is the Navy's afloat spectrum management software tool. It is used throughout the fleet to develop spectrum usage plans and to predict, identify, and mitigate EMI among RF systems. It also predicts intermodulation interference among systems, provides visualization of EMI among units, and ensures that units follow regional and international laws and treaties worldwide.

AESOP was upgraded to include CREW devices (see Figure 2). AESOP helps address the problem of EMI from CREW devices, which could potentially interfere with other U.S. and coalition systems. AESOP's CREW capabilities provide:

- Organic capability with minimal training required
- Visualization of communications quality and EMI severity
- Prediction, identification, and mitigation of interference
- Propagation analyses, based on operational situation, geography, and weather
- Interpretation of engineering analysis results to support tactical decisions
- Interoperability with joint, coalition, host nation, and civilian systems
- CREW parametric data, spectrum emissions, models, and visualization

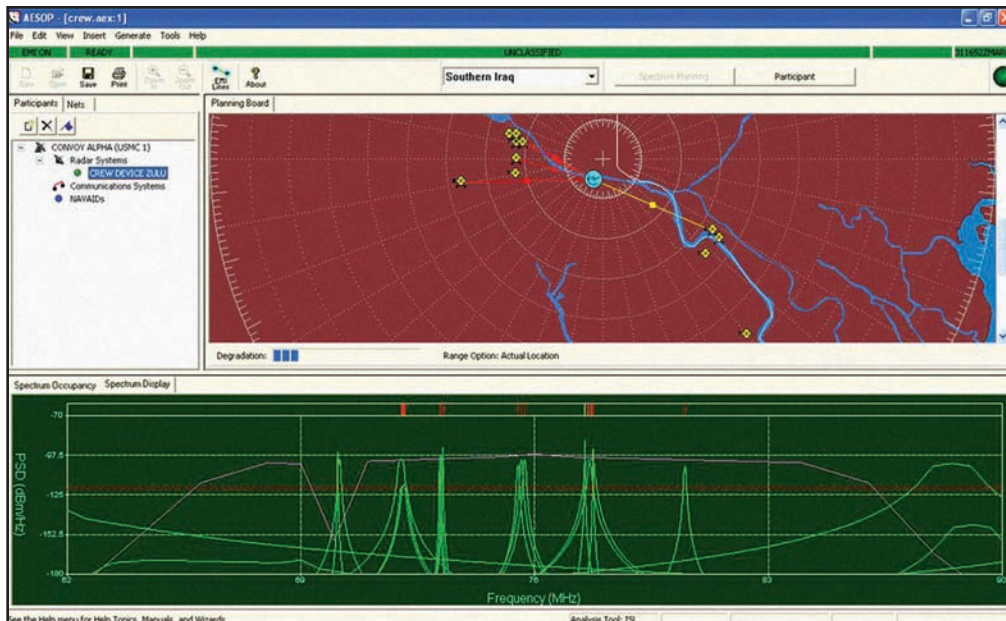

Figure 2. AESOP EW Capability Screenshot

Influence on System Requirements

In addition, the government technical team learned, along with the CREW manufacturers, what was working well with the CREW systems and what needed improvement. This enabled the government team to develop better specifications for next-generation CREW systems, such as baselines 3.1, 3.2, and 3.3. These improvements to specifications have borne fruit, with baselines 3.1 and 3.2 demonstrating increased performance, more flexibility and expandability, and improved EMC. Baseline 3.3 promises even more advances.

EMI Problem Solving

As more systems are added to military ground vehicles, the electromagnetic environment becomes more complex. Many fielded systems today comprise commercial off-the-shelf (COTS) components and, as such, are not designed to operate in a complex electromagnetic environment. Moreover, many systems transmit high levels of energy across a wide band of frequencies, thus saturating the front end of systems. Warfare Center engineers work to design specialized filters, corrugated barriers, and so forth, in order to improve the rejection of in-band energy, thereby allowing simultaneous operation of all systems. Many factors are considered when placing systems on platforms, such as frequency management, in-band and out-of-band emissions, in-band error

handling, case cable penetration, antenna location, cable and terminal shielding, and equipment grounding.

Many of the EMI problems encountered have been worked on in multilaboratory, joint environments. A great example of this is the Blue Force Tracker (BFT) Interference Fix (I-Fix). NSWC Dahlgren Division began experimentation with various prototypes filters and had some success, but the effort developed more momentum when the Army's BFT Program Office, Force XXI Battle Command, Brigade-and-Below (FBCB2) and the Communications-Electronics Research, Development, and Engineering Center (CERDEC) Science and Technology (S&T) division joined the fight. FBCB2 tasked the BFT manufacturer to develop a new version of the FFT with a filter inserted to mitigate the CREW EMI. CERDEC S&T provided test facilities and experienced personnel and, within a matter of months, the final solution was fielded (see Figure 3).

CONCLUSION

Warfighters today are much safer than just a few short years ago, largely due to the E3 community's support to CREW. The success of these efforts enables simultaneous transmissions from CREW and non-CREW systems, thereby assuring warfighter missions. More importantly, they no doubt have saved U.S. and coalition lives.

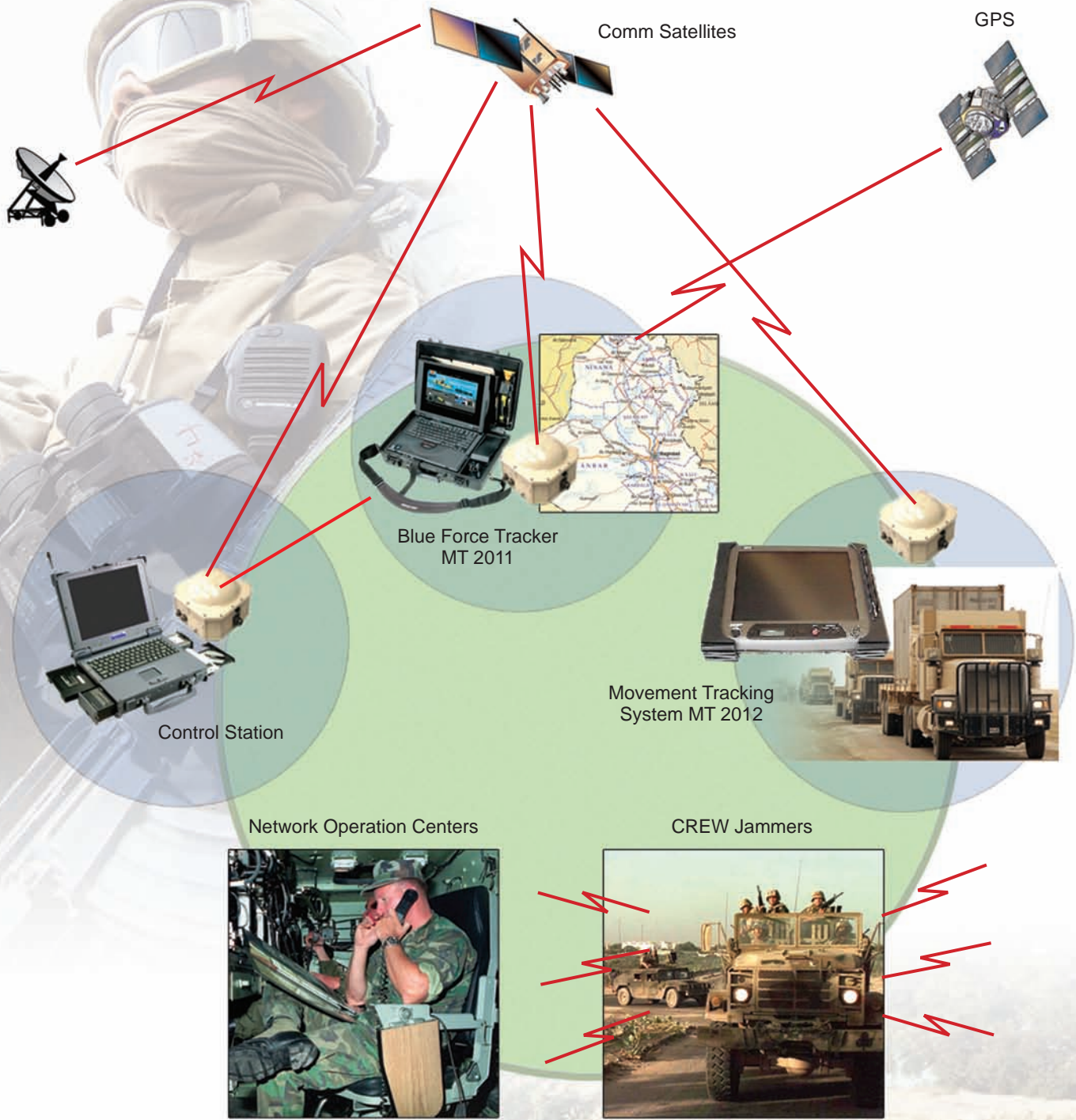
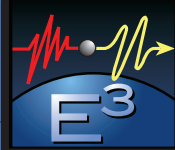

Figure 3. Blue Force Tracker Concept With CREW EMI



INTEGRATED TOPSIDE DESIGN SUPPORT FOR THE U.S. COAST GUARD NATIONAL SECURITY CUTTER

By Richard E. Thompson

The U.S. Coast Guard (USCG) National Security Cutter (NSC) is the flagship of the fleet, capable of meeting all maritime security mission needs. It is the largest and most technically advanced class of cutter in the USCG, with robust capabilities for maritime homeland security, law enforcement, and national defense missions.

At 418 ft, the lead ship in the new *Legend*-class of the NSC is capable of executing the most challenging maritime security missions, including supporting the mission requirements of the joint U.S. combatant commanders. The NSC is the largest and most technically advanced ship class of the Integrated Deepwater System (IDS) program's three major classes of cutters and will replace the aging 378-ft *Hamilton*-class High Endurance Cutters that have been in service since the 1960s. Figure 1 shows the first ship of the class, U.S. Coast Guard Cutter (USCGC) *Bertholf*, Maritime Security Cutter, Large (WMSL 750).

Compared to existing cutters, the NSC's design will provide better seakeeping and higher sustained transit speeds, greater endurance and range, and the ability for launch and recovery of small boats,



Figure 1. USCGC *Bertholf* During Sea Trials

helicopters, and unmanned aerial vehicles (UAVs) in higher sea states—all key attributes enabling the USCG to implement increased security responsibilities. These enhanced capabilities will enable more effective enforcement over foreign-flagged ships transiting U.S. waters. Moreover, Deepwater's more capable maritime security cutters will enable the USCG to screen and target vessels more quickly, safely, and reliably before they arrive in U.S. waters—to include conducting on-board verification through boarding and, if necessary, taking enforcement-control actions. The NSC will serve as an integral part of the USCG's collaborative interagency effort to achieve maritime domain awareness and ensure the safety of the American public and sovereignty of U.S. maritime borders.

THE NAVAL SURFACE WARFARE CENTER (NSWC) DAHLGREN AND USCG TEAMING TOGETHER

The USCG tasked the Naval Surface Warfare Center, Dahlgren Division (NSWCDD), Electromagnetic Environmental Effects (E3) Ship Integration Branch, to serve as topside design agent for the NSC and to address integrated topside design (ITD) and E3 issues in preparation for the ship's post shakedown availability (PSA). The task was not to redesign the NSC, but to integrate new antennas into the existing design, utilizing the available space to maximize performance and minimize impact. Unlike most PSA installations, the planned WMSL 750 PSA effort represented a major integration of electronic equipment and antennas that would provide the NSC with new capabilities to meet the NSC's diverse mission requirements. The principal equipment additions support a Sensitive Compartmented Information Facility (SCIF), navigation, exterior communications (EXCOMM), and electronic support measures (ESM).

NSWCDD's E3 Ship Integration Branch conducted a design, integration, and systems engineering review

for the WMSL 750 and USCG *Waesche* (WMSL 751) topside systems. This effort was a subset of engineering activities managed and coordinated as part of the total ship design effort for the *Legend*-class NSC. The task required coordination, teaming, and liaison with the other engineering, management, and production activities, including:

- USCG Deepwater command, control, communications, computers, intelligence, surveillance, and reconnaissance (C4ISR) and NSC project officers
- USCG Program Manager Representative Office (PMRO)
- Naval Sea Systems Command (NAVSEA) technical codes
- Space and Naval Warfare Systems Command (SPAWAR)
- Naval Air Systems Command (NAVAIR)
- Program Acquisition Resource Managers (PARMs)
- the shipbuilder, Northrop Grumman Ship Systems (NGSS)
- Supporting contractors

Initial efforts included familiarization with the *Bertholf* topside configuration and the development of a three-dimensional (3-D) computer-aided design (CAD) model. The ITD team identified suitable antenna locations for the new antennas, noting the risks involved by integrating the antennas in particular locations. The Total Ship Electromagnetic and Environmental Effects (TSE3) team provided support to the ITD effort by conducting an E3 assessment of the WMSL 750 and by providing E3 inputs to the ITD team. The Computational Electromagnetic Modeling (CEM) group provided CAD and computational analysis support, producing a new 3-D CAD model in Autodesk Inventor by the end of fiscal year 2008 (FY 08). Additionally, the NSWCDD ITD, TSE3, and CEM design teams:

- Conducted ship visits
- Developed an ITD management plan
- Developed a Source-Victim Matrix
- Conducted Blockage Analysis studies
- Updated the 3-D Topside Model
- Organized a Topside Working Group to support USCGC NSC design studies

TAILORED INTEGRATED TOPSIDE DESIGN PROCESS

NSWCDD tailored the ITD process to meet the NSC schedule and scope of work based on the current state of NSC construction and the need to review the current NSC configuration. Although most of the system allocation occurred prior to

NSWCDD participation, there was some reallocation of new systems during the overall process. The basic process remained intact; however, the USCG did not seek ITD certification. The tailored process appears in Figure 2.

MODELING REQUIREMENTS

The USCG provided NSWCDD with a 3-D CAD model of the NSC, previously developed by the ship integrator. This model included the existing antenna configuration planned for the NSC at the time of ship delivery. However, the modeled antennas were generic, in the form of cones and cylinders, and not representative of the actual antennas on board the NSC. Consequently, NSWCDD updated the existing 3-D CAD model to support an immediate need for topside analysis. The updated model would include actual antenna representations required for conducting numerical electromagnetic compatibility (EMC) analysis using the CEM tool set. The updated model would also include the post-PSA antennas. Additionally, NSWCDD determined that a new 3-D CAD model, based on Autodesk Inventor software, would be advantageous to the long-term configuration management requirements of the USCG and future analysis efforts using CEM tools. There were many advantages to using Autodesk Inventor over AutoCAD 3-D, including ease of use, able to convert a 3-D model to a 2-D drawing, and compatibility with CEM tools for numerical analysis. NSWCDD chose to develop the Inventor model in

two versions: the existing ship configuration and the post-PSA configuration. The Inventor model would include the level of detail required to conduct numerical analysis and topside configuration management for major topside items, such as antennas, lights, weapons, vents, etc.

INTEGRATED TOPSIDE DESIGN (ITC) ANALYSIS

The ITD analysis effort began with a basic learning of the NSC mission and communication requirements, followed by an understanding of the individual system operational requirements. The ITD process served as the conduit to marry these distinct requirements, conduct trade-off studies, and produce a topside design to maximize ship mission effectiveness and minimize system interference. No topside design is without risk, however, and the resultant NSC design was no exception. The ITD process served to identify the significant risk items, which appear later in this article.

Due to the limited available topside real estate (resulting from the presence of other topside equipment, including antennas, weapons, lights, cameras, etc.), the topside team initially looked for available topside space where the systems could operate and meet mission requirements. It was obvious, however, that the larger satellite communications (SATCOM) antennas were going to require relocation of some existing antennas to improve overall antenna coverage and to minimize impact to other systems, especially weapons. The design

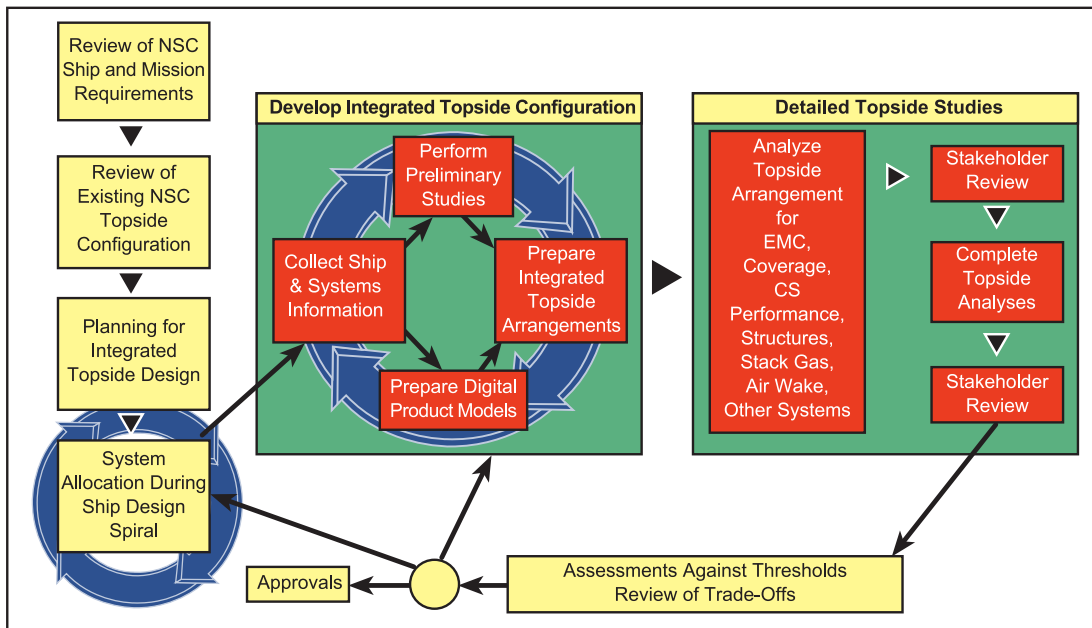

Figure 2. Tailored ITD Process

team identified notional antenna locations utilizing the available topside 2-D drawing provided by the ship builder and the topside model. The design team refined the locations, following ship checks aboard the *Bertholf*, and reviewed analysis results. The SPAWAR System Center conducted the high-frequency (HF) antenna analysis. The following discussion summarizes the analysis followed for the individual topside antennas planned for integration during PSA.

COMPUTATIONAL ELECTROMAGNETIC ANALYSIS (CEM)

NSWCDD conducted CEM analysis to assess the overall NSC electromagnetic (EM) environment, conduct blockage studies, and to analyze the E3 risk due to the integration of PSA antennas. The CEM analysis helped determine the appropriate locations for topside antennas to achieve optimum coverage. The blockage studies utilized Blockage Analysis Model (BAM) and were particularly useful for locating the larger SATCOM antennas. Figure 3 is a sample 3-D CAD model of the topside area above the NSC Pilot House used to evaluate antenna coverage for the numerous topside antennas.

MOVING FORWARD TO MISSION SUCCESS

The additional topside antenna systems planned for the NSC during PSA will provide the NSC with considerable new capabilities in terms of

a SCIF, EXCOMM, navigation, and ESM systems. These new capabilities add approximately 30 new antennas to the ship's topside configuration. The NSWCDD ITD team followed a tailored ITD process to develop a topside design configuration to meet the shipboard mission requirements and maximize the performance capability of the individual systems wherever possible. There were many influences on the design, particularly the limited topside real estate to place the new antennas, the E3 consequences resulting from those antenna placements, and the impacts to weapons and personnel. The limited topside real estate forced some antennas to be in close proximity to each other, increasing the risk of electromagnetic interference (EMI) caused by high EM field strengths or inband interference from transmitting antennas. The impact to weapons was a major concern and resulted in the relocation of SATCOM antennas to minimize any loss in coverage. Personnel safety from radiation hazard (RADHAZ) conditions caused by the addition of two HF 35-ft whip antennas will require testing to identify new RADHAZ areas on the ship. Future efforts will involve the Electromagnetic Effects Division to evaluate potential RADHAZ conditions and to conduct EMI discovery and EMC certification tests to understand the ship's true EM environment. All of these efforts help ensure that the USCG's flagship NSC can safely and effectively perform its maritime homeland security, law enforcement, and national security missions.

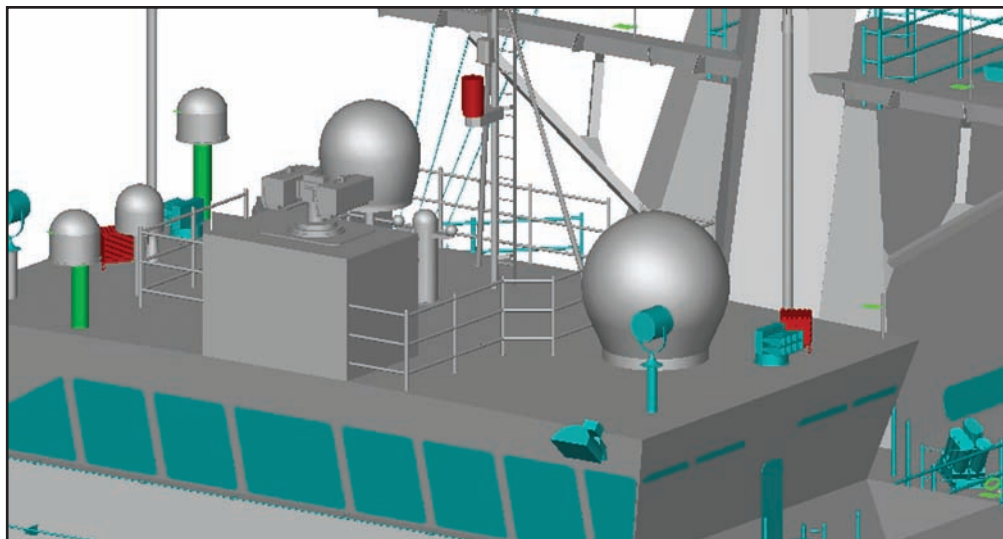

Figure 3. Sample 3-D CAD Model Snapshot



THE STAN DATABASE

By Bob Zanella

Today's topside design and electromagnetic compatibility (EMC) engineers are presented with some very difficult challenges aboard U.S. Navy (USN) ships. Throughout the years, the number of topside antennas aboard USN ships has grown, even though the topside space available has not. Antennas are not only located on the topside of ships, but below decks as well for such things as damage control communications. In addition, the shipboard systems that are connected to these antennas emit signals, sometimes unintentionally, that may be in an adjacent or overlapping frequency band with neighboring systems. Finally, the duty cycles of shipboard radars, which is the ratio between the transmit pulse width and pulse repetition interval (PRI), continue to increase and stress the interference rejection capabilities of shipboard receivers. Both ownship and offboard emissions—from other ships or shore-based infrastructure—create a unique and stressing operational electromagnetic environment (EME) for shipboard systems. Due to this EME, interactions occur between systems that degrade their operational effectiveness and performance, which could put the ship and its crew in danger. These interactions are considered electromagnetic interference (EMI).

The Shipboard Electromagnetic Compatibility Improvement Program (SEMCIIP) was created by the Naval Sea Systems Command (NAVSEA) to combat EMI problems aboard surface ships and submarines. The primary tool used by SEMCIIP is

the SEMCIP Technical Assistance Network (STAN) database, which is managed by the Naval Surface Warfare Center, Dahlgren Division (NSWCDD), Electromagnetic Environmental Effects (E3) Force Level Interoperability Branch. STAN is the Navy's official repository for EMI control and radiation hazard (RADHAZ) data for systems, ships, submarines, and strike groups. Figure 1 shows the STAN home page.

STAN is a web-based application that currently serves over 700 users. It contains data on over 1,100 EMI problems that have been observed over the past several decades. The user base for STAN consists of military, government civilian, and contractor representatives, who requested an account free of charge. Military users include personnel from the fleet, regional maintenance centers (RMCs), the Board of Inspection and Survey (INSURV), and various commands. Government civilian and contractor users include engineers, technicians, and managers who support the fleet from system commands, warfare and system centers, RMCs, shipyards, program executive offices (PEOs), and various others.

STAN provides several products that are used on a daily basis. Primary products include EMI brief sheets and their associated affected ships list,

EMI test procedure, tailored ship equipment lists, and a vast E3 document library. Additional products are available in STAN, such as EMI problem listings by selected criteria, electromagnetic (EM) control drawings, and the Ship EMC Certification test plan generator, to name a few. This article, however, will focus on STAN's primary products.

ELECTROMAGNETIC INTERFERENCE (EMI) BRIEF SHEET

The EMI brief sheet is the most important product provided by STAN. A brief sheet is created for every unique EMI problem that is observed in the fleet. Each problem is assigned a number called a SEMCIP Problem Number (SPN). The EMI brief sheet includes the source and victim systems involved, the problem category (based on the severity of the problem), the problem status (whether the problem is being worked or is resolved), and the SEMCIP engineer assigned to solve the problem. The body of the brief sheet consists of a description of the problem; its operational impact; recognition symptoms; and the fix identification description (ID) and status fields. For example, Figure 2 is the EMI brief sheet for SPN 1-07.

The EMI brief sheet's problem description section provides an overview of what the problem is

The screenshot shows the SEMCIP Technical Assistance Network (STAN) homepage. At the top left is the NAVSEA logo (Naval Sea Systems Command). The main header reads "SEMCIP Technical Assistance Network" and "Unclassified – Administrative / Operational Use". A navigation bar shows "HOME > STAN System". Below this is a search bar with a "Go!" button. A central banner displays "4/17/2008 - Search Engine" and "Welcome to STAN" above a large SEMCIP logo. The logo is circular with the text "SHIPBOARD ELECTROMAGNETIC COMPATIBILITY IMPROVEMENT PROGRAM" and "A NAVSEA PROGRAM SEMCIP". To the right of the banner is a "Web Links" section with links for "Recent Bulletin Board Entries", "Privacy Policy", "Cookie Disclosure Statement", "System Notices", "External Links Policy", and "DOD Disclaimer". Below the links is a list of three items: "Click here to update your personal information and password.", "Click here to leave a comment or send the STAN Administrators feedback.", and "Click here to view helpful hints for the New STAN site." At the bottom, a footer states "This is an Official U.S. Navy Web Site" and "This information resides on a DOD interest computer. Important conditions, restrictions, and disclaimers apply." It also notes "This site has been accessed 121563 times since November 2000."

Figure 1. STAN Homepage

Problem Number 1-07	Suffix HA	Problem Status RESOLVED	Coupling Path ANTENNA TO CASE/CABLE	Revision Date 1/15/2009
Source AN/SPS-40		Victim B&A CRANE		Modifier SPS-40 MAIN BEAM
Problem Solver		Activity		Phone

Problem Description

Description:
The following ship classes have the source/victim pair installed: LPD 4.

The AN/SPS-40 causes electromagnetic interference (EMI) to the boat and aircraft (B&A) crane. The AN/SPS-40 severely impacts the operation of the crane by affecting the electrical input signals to the Rexroth hydraulic proportional directional valves. This causes their hydraulic outputs to shake the crane boom each time the AN/SPS-40 antenna points towards the cab of the crane.

LPD 4 Class - (Cat 1) Severe interference has been observed aboard USS *Ponce* (LPD 15). On LPD 15, the SPS-40 is located 46 feet lower on the mast than on the rest of the LPD 4 Class. Therefore, more of the SPS-40 main beam impinges on the crane electronics on LPD 15 and causes EMI problems. The higher elevated SPS-40s on the other ships of the LPD 4 Class do not cause EMI to their cranes.

Operational Impact:
Unsafe crane operations.

Recognition Symptoms:
The crane boom shakes when the AN/SPS-40 antenna points towards the crane cab.

Solution

Fix ID:
METAL ENCLOSURE/EMI CONNECTOR

Description:
The fiberglass enclosure that contained the programmable logic controller (PLC) was replaced with a metal enclosure. The stuffing tubes where cables entered the fiberglass enclosure were replaced with connectors and EMI backshells. Where cable shields were present, they were connected to the EMI backshells. The metal enclosure and EMI connectors mitigated the effects of the AN/SPS-40 energy on the crane electronics enough to fix the problem on LPD 15.

Status

Description:
LPD 4 Class - the metal enclosure and EMI connectors are installed aboard LPD 15. The remaining ships of the class do not require the EMI fix.

Figure 2. STAN EMI Brief Sheet

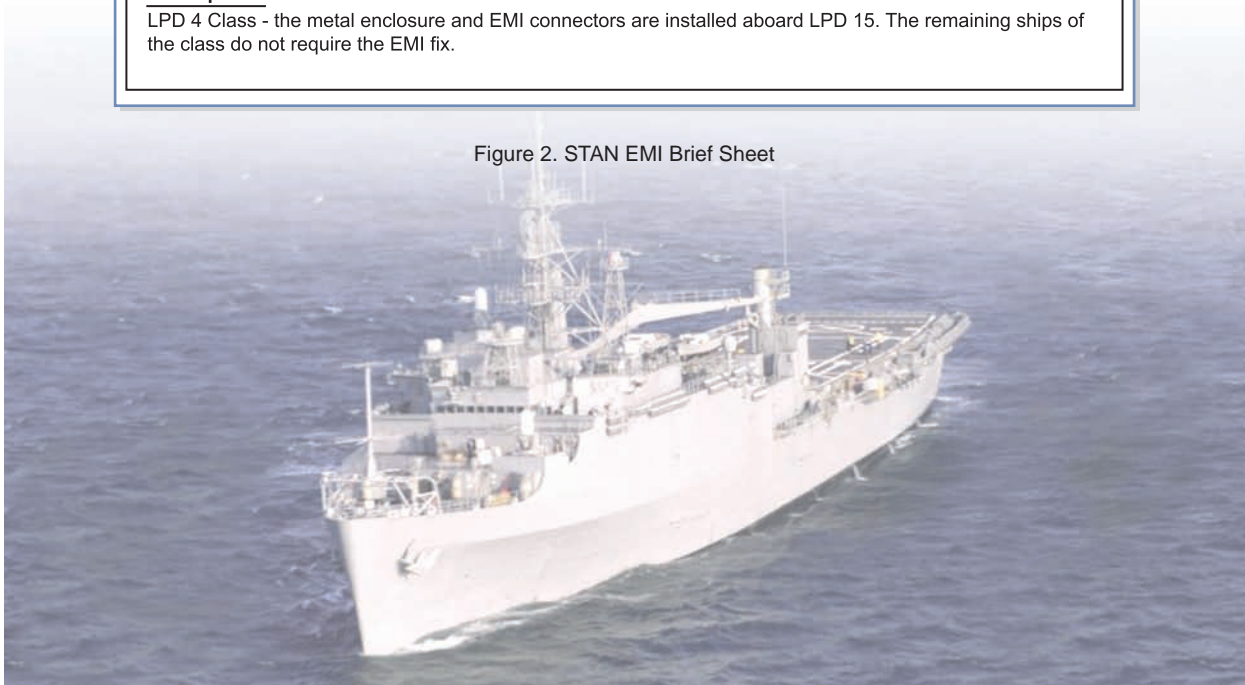

and the interference mechanism(s) involved. It includes a breakout of all the ship classes that have the source-victim pair installed and ship class-specific data related to the EMI problem. The operational impact section describes what the mission impact is to the ship if the EMI is present. The problem category is derived from the operational impact. If the victim system is unable to perform its mission, it is a category 1 problem. If the victim system is able to perform its mission in a degraded state, it is a category 2 problem. If the victim system is able to perform its mission with the EMI being more of a nuisance, it is a category 3 problem. The recognition symptoms section provides data on how to recognize if an EMI problem is present. For example, this will state whether to monitor a satellite communications system's bit error rate (BER) for an increase or observe a radar's plan position indicator (PPI) display for a decrease in contacts and range. The fix ID section lists any permanent or interim fixes that were developed to mitigate the EMI. The fix description section provides the specifics of the fix(es). Finally, the fix status section includes a breakout of the ship classes that have the fix installed or information on why a particular ship class may have the EMI problem but not have the fix installed. Also, if a fix has not been determined yet, this section provides information on possible fixes that are being assessed.

AFFECTED SHIPS LIST

The affected ships list goes hand-in-hand with the EMI brief sheet. This is a list of all the ships that may be affected by the problem. In the ship status field, the ship may have a status of predicted, confirmed, or fixed. Predicted means that an assessment was made and it was determined that—based on other ships in the class having the EMI problem or due to the likelihood of the EMI problem occurring on this ship—the ship should reflect this status. Confirmed means that the EMI problem was observed aboard this

ship. Fixed means that the EMI fix has been installed aboard this ship. The list also includes the fix installation date, if fixed, what fix was installed or needs to be installed, and the documentation that verified the ship status. Figure 3 is the affected ships list for SPN 1-07.

EMI TEST PROCEDURES

Step-by-step EMI test procedures are developed for all category 1 and 2 problems. There are two types of test procedures: recognition and visual. Recognition test procedures are created to determine if an EMI problem is present. To make this



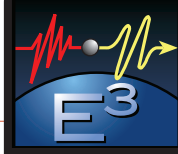

Status of Problem 1-07-HA on Affected Ships

<u>Problem No.</u>	<u>Source Victim Modifier</u>	<u>Prob. Status</u>	<u>Category</u>
1-07-HA	AN/SPS-40 B&A CRANE SPS-40 MAIN BEAM	RESOLVED	1

<u>Hull No. Class</u>	<u>Ship Status</u>	<u>Scheduled Installed</u>	<u>Fix ID</u>	<u>Remarks</u>
LPD-15 (LPD-4)	FIXED	COMPLETE 1/15/2009	METAL ENCLOSURE/EMI CONNECTOR	FIX (I), SEMCIP VERIFIED, DOC 85603

Total Corrected: 1
 Total Uncorrected: 0
 Total Ship(s) Affected: 1

Figure 3. Affected Ships List

determination, the possible EMI victim system is monitored for degradation while the possible EMI source system is transmitted in various modes or cycled between the on and standby/off state. A visual test procedure is created to verify that a required EMI fix is installed. Each procedure includes data sheets that should be filled in during the test. The EMI test procedures play a vital role in Ship EMC Certification events, which ensure that all required EMI fixes are installed and that all EMI problems have been identified aboard a ship.

SHIP EQUIPMENT LIST

STAN has an equipment list for each ship tailored to focus on EMI-relevant systems. On the list, the equipment is divided into the following categories:

- Electronic warfare (EW)
- Hull, mechanical, and electrical (HM&E)
- Avionics
- Navigation
- Sonar
- Communications
- Radar
- Weapons

These lists are verified/updated as part of each Ship EMC Certification event.

E3 DOCUMENT LIBRARY

The last primary product that STAN provides is a vast E3 document library. It includes EMI test reports, ship EMC certification reports, RAD-HAZ survey reports, and E3 policy and guidance documents, among others. Many documents are available online, with the remaining available by contacting STAN database personnel. Figure 4 is the document list for SPN 1-07.

A shipboard radar, communication, or EW system degraded by EMI can put the ship and its crew in danger. If not for SEMCIP, aided by the STAN database, warfighters might not be able to successfully perform their missions. By using STAN, EMI problems and fixes can be quickly identified, if the problem was previously observed. If not, the EMI problem details are recorded in STAN as SEMCIP works towards mitigating the EMI. As one can see, STAN is a one-stop shop for E3 data and is vital for ensuring that shipboard systems oper-

Document List for Problem 1-07-HA				
<u>Problem No.</u>	<u>Source Victim Modifier</u>	<u>Prob. Status</u>	<u>Category</u>	
1-07-HA	AN/SPS-40 B&A CRANE SPS-40 MAIN BEAM	RESOLVED	1	

<u>Doc Date</u>	<u>Doc#</u>	<u>Doc Type</u>	<u>Originating Activity</u>	<u>Title/Subject</u>	<u>FICHE # ROW COL</u>
1/15/2009	85603	PROBLEM UPDATE	NSWCDD Q54	SPN 1-07 BRIEF SHEET UPDATE	
8/20/2008	84391	STAN EVENT NOTIFICATION	NSWCDD	SPS-40 TO SHIPS CRANE ON LPD 15	
7/15/2008	83991	PROBLEM UPDATE	NSWCDD, Q54	FORMATTED SPN 1-07 BRIEF SHEET	
3/13/2008	83077	PROBLEM UPDATE	NSWCDD, Q54	UPDATES TO SPN 1-07	U- ROM35
8/22/2007	81883	EQUIPMENT INFO	NSWCDD	LPD 15 EMI ISSUE: SPS-40 RADAR TO B&A CRANE	U- ROM35
7/6/2007	81643	EMI SURVEYS	GENERAL DYNAMICS IT	SEMCIP ACTIVITY REPORT: Q54-07-052 AN/ SPS-40 EMI TEST TO CRANE ABOARD USS PONCE (LPD 15)	U- ROM34
6/18/2007	81503	EQUIPMENT INFO	NSWCDD	LPD-15 EMI ISSUE: SPS-40 RADAR TO B&A CRANE	U- ROM34
6/18/2007	81504	EQUIPMENT INFO	NSWCDD	USS PONCE (LPD 15)	U- ROM34
6/15/2007	83276	EMI CASREP	NSWCDD	CRANE EMI CASREP ABOARD USS PONCE LPD 15 (U)	
5/28/2007	83278	EMI CASREP	NSWCDD	CRANE EMI CASREP ABOARD USS PONCE LPD 15 (U)	

10 Documents Found

Figure 4. Document List

EMI STRIKE GROUP CAPABILITIES AND LIMITATIONS

By John Gammon, II and Alexi Schandl

FOUNDATIONAL EFFORTS

U.S. naval strike groups (SGs) must remain ready to perform their missions despite challenges in the electromagnetic (EM) environment. Naval Sea Systems Command (NAVSEA), Electromagnetic Capability and Spectrum Management (SEA 05H34), focuses on EM controls to ensure that emitter systems do not create interference for combat systems. An essential part of maintaining controls has to do with understanding SG capabilities and limitations (C&L) with respect to electromagnetic environmental effects (E3).

Naval Surface Warfare Center, Port Hueneme Division (NSWC PHD) initially developed paper C&L products, which led to web-based combat system C&L manuals starting over 20 years ago. The Strike Group C&L is NAVSEA's report out to warfighters and trainers about everything the technical community knows concerning tactical data link (TDL) and the Global Command and Control System (GCCS) operations and systems interoperability. C&Ls are delivered and frequently updated via the Secure Internet Protocol Router Network (SIPRNET); they have also been made available to the fleet on CD-ROM to accommodate limited or no SIPRNET connectivity. NAVSEA (SEA 05) sponsors the interoperability C&L and funds conversion of C&L data into extensible markup language (XML) format to facilitate exchange of technical information with weapon, combat system, and electromagnetic interference (EMI) C&L projects.

The requirement to share technical data and provide the best products to the fleet started a synergistic partnership between NSWC PHD and the Naval Surface Warfare Center (NSWC) Dahlgren. They continue working together to support fleet awareness of EMI and electromagnetic compatibility (EMC) for topside antenna, sensor and weapon systems, and for systems located within the hulls of naval vessels.

EMI STRIKE GROUP C&L PRODUCT DEVELOPMENT

NAVSEA's Strike Group Electromagnetic Environmental Effects (E3) and Spectrum Management Engineering Branch, which holds the technical warrant for EMI/EMC and spectrum management, subsequently established the Strike Group EM Engineering Concept of Operations (CONOPS) Process. This process provided a methodology for achieving SG EM interoperability within the Fleet Response Plan. One of the elements of the EM Engineering CONOPS was to ensure that SG deficiencies, impacts, and risks to warfighting capacity were identified and documented in a readily accessible C&L application. Requirements stemmed, in part, from a survey that was

provided to shore squadrons in Little Creek, Virginia, to gain insights on EMI and EMC product viability and fleet effectiveness. The results of this survey culminated in the need for a comprehensive source of interference data, a high-level EMI summary, and a centralized source of EMI and radiation hazard (RADHAZ) data. That then led to the development of NSWC Dahlgren-produced software capable of producing web-page-based CDs that would allow SG commanders and platform commanding officers the ability to search for overall system impacts and ship specific impacts due to EMI, RADHAZ, and littoral frequency operational restrictions (Afloat Electromagnetic Spectrum Operations Program (AESOP))—products produced for the fleet by NSWC Dahlgren's E3 Force Level Interoperability Branch.

DATA MANAGEMENT

The EMI Strike Group C&L Data Management System takes data from multiple sources and filters and selects data pertinent to a particular SG by platform and systems. ColdFusion software converts the data into hypertext markup language (HTML); JAVA (platform-independent, object-oriented programming language) scripts; and cascading style sheet (CSS) files. The product is provided to SGs via the SIPRNET web pages and also by

CD-ROM delivery to each ship within a given SG. A depiction of the C&L Data Management System is shown in Figure 1.

C&L helps improve fleet awareness of E3 and impacts for all ships and associated systems. C&L navigation requires only the availability of Internet Explorer (web browser) and Adobe Acrobat Reader. It affords fleet users access to Port Hueneme- and Dahlgren-produced products, including SEMCIP, AESOP, and RADHAZ products—all of which are used in direct support of the Electromagnetic Interference (EMI) Strike Group C&L product. The application also hosts platform-centric data, including littoral frequency restrictions and system-centric EMI source-victim assessments (EMI executive summaries). All of this data helps facilitate making EM impacts and vulnerabilities to ship systems understandable to the warfighter. A depiction of the EMI Strike Group C&L application is shown in Figure 2.

PRODUCT USE AND NAVIGATION

Separate pull-down menus handle online product navigation. SG links lead users to specific SGs. The HELP Menu provides navigation to actual HTML SG products. References provide additional information concerning SEMCIP, SEMCIP points-of-contact, and EMI-EMC terms

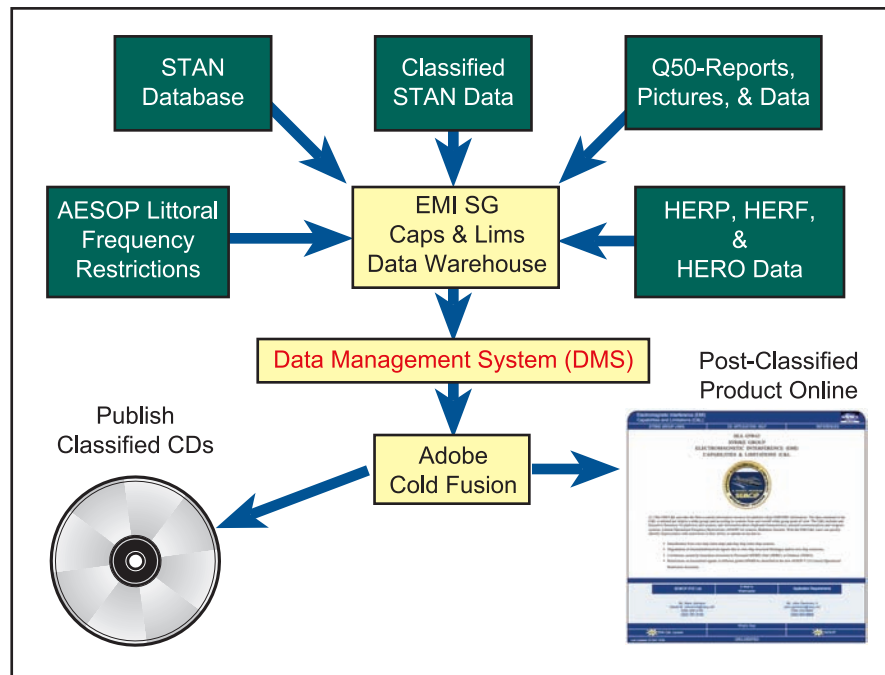

Figure 1. EMI SG Capabilities and Limitations Data Management System (DMS)

Electromagnetic Interference (EMI)
Capabilities and Limitations (C&L)

STRIKE GROUP LINKS

CD APPLICATION HELP

REFERENCES

SEA 05H34
STRIKE GROUP
ELECTROMAGNETIC INTERFERENCE (EMI)
CAPABILITIES & LIMITATIONS (C&L)

(U) The EMI C&L provides the fleet a central information resource for platform (ship) EMI/EMC information. The data contained in the C&L is tailored per ship (in a strike group) and according to systems from an overall strike group point of view. The C&L includes and Executive Summary for platforms and systems, and information about shipboard characteristics, selected communications and weapons systems, Littoral Operational Frequency Restrictions (AESOP) for systems, and Radiation Hazards. With the EMI C&L, users can quickly identify ships/systems with restrictions in their ability to operate at sea due to:

- Interference from own-ship (intra ship) and ship-ship (inter ship) systems;
- Degradation of transmitted/received signals due to own-ship structural blockages and/or own-ship emissions;
- Limitations caused by hazardous emissions to Personnel (HERP), Fuel (HERF), or Ordnance (HERO);
- Restrictions on transmitted signals in different global OPAREAs identified in the new AESOP V 2.0 Littoral Operational Restriction document.

SEMCIP POC List

E-Mail to Webmaster

Application Requirements

EMI C&L Update

What's New

AESOP

Last Updated 22 MAY 2008

UNCLASSIFIED

Figure 2. Strike Group Electromagnetic Interference (EMI) Capabilities and Limitations (C&L)

and definitions. An unclassified depiction of the classified web-page application is shown in Figure 3.

EMI STRIKE GROUP C&L PRODUCT DELIVERY AND USAGE

During the course of fiscal year 2008 (10/2007–8/2008), there were 11 EMI Strike Group C&L SG deliveries, which encompassed 64 ships and 11 shoreside commands (deliveries). These deliveries consisted of online web-posting of each SG, coupled with delivery of CDs to each ship within each SG (and to each shoreside command). Online usage metrics revealed that the EMI Strike Group C&L web page was accessed 924 times throughout

the fiscal year. Additionally, there were between 78 and 243 hits (web accesses) per SG. Other areas of notable usage within each SG were:

- EMI documents (brief sheets used to describe EMI problem characteristics, impacts, and solution workarounds)
- RADHAZ Surveys (hazards of electromagnetic radiation to personnel (HERP) and hazards of electromagnetic radiation to ordnance (HERO)) and related core HERP–HERO publications (OP 3565 Volumes 1 and 2)
- Frequency management (AESOP) data and documents (OP 3840 and AESOP Littoral Operational Restrictions)

Electromagnetic Interference (EMI) Capabilities and Limitations (C&L)		
STRIKE GROUP LINKS	CD APPLICATION HELP	REFERENCES
<p>STRIKE GROUP LINKS</p> <p>BONHOMME RICHARD (LHD 6) ESG 07 SSG 07-02 ESSEX (LHD 2) ESG 07 KEARSARGE (LHD 3) ESG 07 HARRY S. TRUMAN (CVN 75) CSG 07 THEODORE ROOSELVE (CVN 71) CSG 08 IWO JIMA (LHD 7) ESG 08 AFSB 082 GEORGE WASHINGTON (CVN 73) CARAT 08 OTHERS, PLANNED</p>	<p>HELP MENU</p> <p>What is EMI CAPS & LIMS Using EMI CAPS & LIMS Table of Contents Download Help Document (2.9 MB PDF)</p> 	<p>REFERENCES</p> <p>EMAC Brochure (7 MB PDF) SEMCIIP Brochure (1.4 MB PDF) EMI-EMC Terms and Definitions (153KB PDF) SEMCIIP, EMI, & EMC Points of Contacts (30KB PDF) EMI C&L Survey (TBD)</p>
<p>(U) The EMI C&L provides the fleet a central information resource for platform (ship) EMI/EMC information. The data contained in the C&L is tailored per ship (in a strike group) and according to systems from an overall strike group point of view. The C&L includes and Executive Summary for platforms and systems, and information about shipboard characteristics, selected communications and weapons systems, Littoral Operational Frequency Restrictions (AESOP) for systems, and Radiation Hazards. With the EMI C&L, users can quickly identify ships/systems with restrictions in their ability to operate at sea due to:</p> <ul style="list-style-type: none"> • Interference from own-ship (intra ship) and ship-ship (inter ship) systems; • Degradation of transmitted/received signals due to own-ship structural blockages and/or own-ship emissions; • Limitations caused by hazardous emissions to Personnel (HERP), Fuel (HERF), or Ordnance (HERO); • Restrictions on transmitted signals in different global OPAREAs identified in the new AESOP V 2.0 Littoral Operational Restriction document. 		
SEMCIIP POC List	E-Mail to Webmaster	Application Requirements
 EMI C&L Update	What's New	 AESOP
Last Updated 22 MAY 2008		
UNCLASSIFIED		

Figure 3. EMI Strike Group Capabilities and Limitations Web Page

NAVSEA WARFARE CENTER COLLABORATION

NSWC PHD and NSWC Dahlgren teaming together resulted in enhanced fleet support. These joint efforts not only provided warfighters with readily accessible system impact awareness, but also with problem resolution and workarounds for topside systems. The NSWC Dahlgren EMI C&L development team worked closely with NSWC PHD's C&L team to set up an EMI Strike Group product web page within NAVSEA's C&L SIPRNET site. Remarkably, there were no developmental costs involved beyond a few man-hours for EMI Strike Group C&L web-page design and publishing. Subsequent efforts

resulted in the classified AESOP web page also being hosted on the NAVSEA C&L web server and, again, there were minimal costs in the migration of the AESOP data to the NAVSEA C&L SIPRNET site.

As a result of NAVSEA and NSWC's collaborative efforts, sailors now have real-time, online access to classified EMI Strike Group C&L information, giving them a technically accurate and user-friendly product for making informed decisions about platform and SG readiness. It also gives fleet operators communications and reach-back access to E3 expertise located in the Electromagnetic Mission Assurance Center (EMAC) at NSWC Dahlgren, Virginia.



WHEN THE NAVY IS NOT FIGHTING, IT IS TRAINING.
WHEN THE NAVY IS FIGHTING, IT IS TRAINING.

By Wayne Lutzen



WHEN THE NAVY IS NOT FIGHTING, IT IS TRAINING.
WHEN THE NAVY IS FIGHTING, IT IS TRAINING.

These are exciting times for Navy training and the electromagnetic compatibility (EMC) disciplines. Both areas have undergone a period of transition in recent years and are continuing to evolve in a spirit of joint cooperation.

Some of the influences listed below have played critical roles in the work being performed and are pivotal to understanding the rationale behind this effort.

- Pentagon personnel are getting grayer. According to estimates, between 40–60% of the Defense Department’s total civilian workforce will be eligible to retire in the next 3–5 years. (Positions will need to be filled at the right skill levels.)
- We have a new generation (“Millennium” or “Gen Y”) of sailor entering the Navy that grew up with the Internet, who is collaborative and technologically savvy.
- There are preferred training formats (i.e., instructor-led training (ILT), distance learning (e-Learning), simulated, virtual, etc.).
- There is a transition to joint warfare.

This article highlights those NAVSEA 05W43 actions in support of the Revolution in Training (RiT).

IMPETUS

Several major changes in philosophy and organization—both in the Navy and as a result of industry’s perception of training—have combined to create a new and dynamic career environment for naval personnel in electromagnetic environmental effects (E3) and spectrum management (SM) disciplines. For many years, both the Navy and industry have seen rapid growth in the development of e-Learning to support ILT and as stand-alone training to reach large, geographically dispersed audiences. These changes in training philosophy coincided with program transitions and organizational changes within the Department of the Navy (DON).

- The Chief of Naval Operations (CNO) established the Naval Education and Training Command (NETC), which replaced the Chief of Naval Education and Training (CNET).
- NETC launched the RiT with the goal of creating a systematic approach to training, supported by continuums of learning, with job assignments matched to those skills required by fleet missions.
- Navy, from the top down, has advocated a charter under RiT in which every person in a position of authority has an obligation

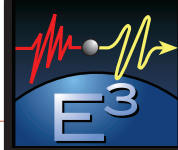

to the mission and to support each sailor's growth to its fullest potential. The mission of the NETC is to educate and train those who serve, providing the tools and opportunities that ensure fleet readiness and mission accomplishment, enhance professional and personal growth and development, and enable lifelong learning.

- Department of Defense (DoD) policy since 2004 has stressed the need to develop mission essential tasks (METs) for all assigned missions, to use information technology to collect near real-time data on mission readiness, and to train all personnel and components on their METs. The ultimate goal is to provide a lean, quick, and agile organization capable of providing properly trained personnel to the fleet, thereby increasing operational readiness and maximizing mission accomplishment.

NAVY TRAINING SYSTEM PLAN (NTSP)

As directed by the CNO, the NTSP provides the framework and details the requirements for implementing E3/SM training for Navy and Marine Corps ships, aircraft, and shore stations. The NTSP addresses selected formal training and on-board training (OBT) courses for DON personnel responsible for the design, development, production, test, installation, operational use, and maintenance of equipment, systems, and platforms.

Naval Sea Systems Command (NAVSEA) 05H343 is the Principal Development Agent for the E3/SM NTSP. NAVSEA assigns the Space and Naval Warfare Systems Center (SPAWARSYSCEN) Atlantic 56170 as the In-Service Engineering Agent (ISEA) responsible for the engineering, updating, coordination, maintenance, publication, and distribution of the NTSP. The three warfare sponsors (i.e., SPAWARSYSCEN Atlantic, the Naval Undersea Warfare Center Division Newport (NUWCDIVNPT), and the Naval Air Systems Command (NAVAIR)) are each responsible for developing, updating, and maintaining related E3/SM courseware for ship, submarine, and air platforms.

WHERE WE ARE NOW—THE ALIGNMENT OF TRAINING TO MISSION ESSENTIAL TASKS

Training is an integral part of the U.S. Navy's preparation to go anywhere, take on any adversary, and win! As such, Navy units train as they expect to fight. This warfighting training philosophy provides the Navy with a unifying goal for individual

and collective training. With this common thread woven throughout Navy units, and with the nation requiring greater accountability of public funds, effective and efficient training must focus on attaining and maintaining the state of operational readiness of fleet units.

The DoD is seeking to meet this need by requiring a Fleet Training Continuum that is capabilities-based and derived from authoritative METs.^{1,2} Policy³ now requires all DoD components to develop METs or similar indicators for all assigned missions and use information technology to collect near real-time data on the readiness of military forces and support organizations to perform these missions.

Based on DoD and Navy policy, NAVSEA, SPAWARSYSCEN Atlantic, and the Naval Network Warfare Command (NETWARCOM), in partnership, are positioning the naval EMC and SM community to provide maximum warfighting capabilities to the combatant commander.

To this end, the implementation of the Navy Warfare Training System (NWTs) has begun. The NWTs is a means of sharing the knowledge base of Navy mission essential task lists (NMETLs), judging readiness, and improving the training and readiness processes. Information from different groups pursuing training tasks can be shared and compared by using the Navy Training Information Management System (NTIMS).

Figure 1 represents a "Navyized" version of the Joint Training System (JTS). The NWTs is a cyclic building block approach to training naval forces based on METs.

- **Requirements**—Analysis of mission leads to a list of tasks with associated conditions and standards. Analysis of essentiality, along with organizations that play a part, produces a mission essential task list (METL), which feeds the plans phase. Requirements are derived from assigned missions based on command's core missions and Joint/Naval Doctrine. The requirements phase will produce the NMETLs, tasks, conditions, and standards.
- **Plans**—Uses the NMETL to answer the question who, what, when, where, and how training will be conducted. Training methods and resources are allocated to training requirements. Output is training plans at all levels.
- **Execution**—Completes the training events and collects necessary data, observations, lessons learned, and after action reports (AARs). This information feeds the assessment phase.

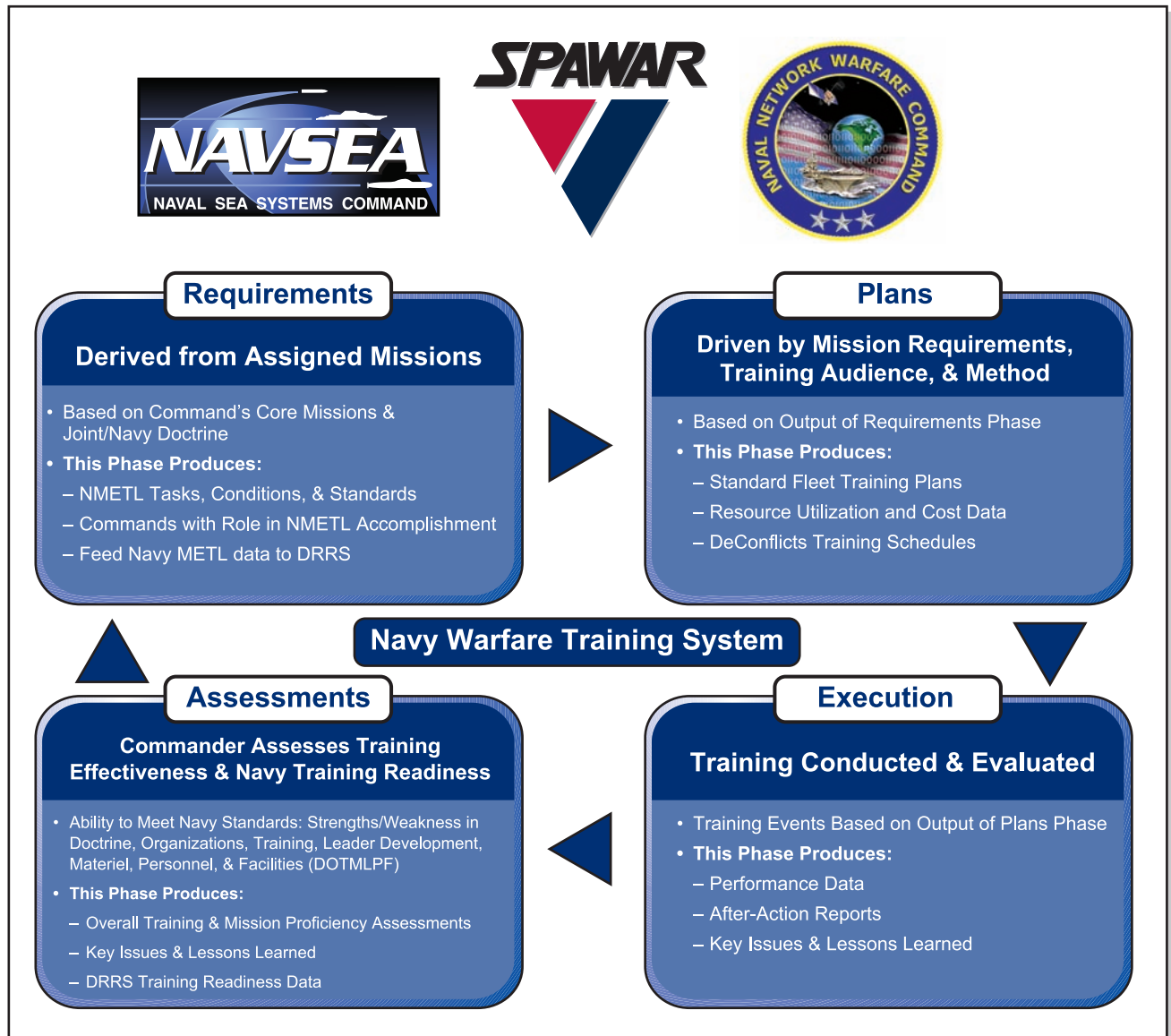

Figure 1. The Naval Warfare Training System (NWTS)

- **Assessment**—Determines mission capability from a training viewpoint. Provides feedback to adjust or improve training.

SPAWARSYSCEN Atlantic has led the charge in the Requirements Phase by collecting all policy and guidance relating to the organizations that support the Navy's electromagnetic interference (EMI) control and SM programs. This was a year-long effort to gather materials and meet with subject matter experts (SMEs).

In support of the Requirements Phase, NETWARCOM and SPAWARSCEN Atlantic sponsored an "E3-SM NTSP and Manpower, Personnel, and Training (MPT) Requirements Review" on 25–29 September 2006. The conference was in support of the CNO's RiT. The purpose of the conference was to unify E3/SM SMEs and develop the job task analysis (JTA) for E3/SM. The JTA process documents all skills required for E3/SM performance and operational requirements. These skills support



manpower and training required at all levels of the Navy. E3/SM disciplines are currently supported by Navy Enlisted Classifications (NECs) ET-1419, IT-2301, and IT-2302.

The conference resulted in the validation of the JTA skills. Two working groups (E3 and SM) reviewed and arbitrated the required JTAs for personnel at all five tier levels (from fleet unit to the national level). As a part of the JTA process, the groups conducted a detailed review of each tier, including discussions of task, subtask, and steps, and the knowledge, tools, and resources for each task, followed by measure assignments for each task and subtask. The group determined the E3/SM respective Manpower Career Paths for U.S. Navy enlisted, officer, contractor, and government service personnel. Based on data developed during the JTA process, initial Navy mission essential tasks (NMETs) were reviewed for the respective E3/SM mission areas.

These NMETs will provide the basis for training requirements and identify the required level of readiness, resulting in the implementation of curriculum standards and an adequate manning and resourcing training continuum. The proposed SM and EMI control METs are being refined and entered into the NTIMS for assignment to organizations that have task performance responsibilities. The Defense Readiness Reporting System–Navy (DRRS-N) will allow operational commands to report the status of meeting required mission capabilities as related to E3, EMI Control, EMC, SM, and electromagnetic pulse (EMP) protection.

Once the mission, function, tasks, standards (measures and criteria) have been agreed upon and approved, the efforts to develop specific training to a specific NMET will begin. The mapping of SM/EMI Control NMETs to Organizational Learning Goals will allow for the development of Navy Learning Objective Statements (NLOS), which will aid in determining the number of courses that will be needed to fulfill SM/EMI control manning and training requirements as well. This will affect all organizations and personnel (enlisted, officer, contractor, and government). When the approved SM/EMI control NMET measures are assigned to

the applicable organization within NTIMS, metrics can be collected within DRRS-N to determine if the NMET is being performed to a specified requirement.

NKO COMMUNITY OF PRACTICE (COP) WEBSITES

Navy Knowledge Online (NKO) is a web portal (see Figure 2) used by active duty, reserve, retired, enlisted, and officers of the U.S. Navy. It is also open to civilians and contractor support personnel. NKO provides information and resources such as career management, personal development, leadership, learning, references, and more. These resources can be used for personal and professional development, including: Navy electronic training (e-Learning), tapping into the wealth of knowledge held by retirees, and otherwise sharing knowledge.

- Navy e-Learning provides eight courses related to EMI control for surface, submarine, and air platforms. These training courses are examples of education that a sailor, a government employee, or a contractor can use.
- Allowing Navy retired personnel access to NKO is one smart strategy for making this large pool of knowledge available to current active duty and reserve personnel. By keeping the channels open among retired, active duty, and reserve, the communications pipeline stays open, and knowledge is shared.
- One interesting way of sharing information is through the COP program. COP allows people in a specific interest group to share best practices, advice, and expertise in organizational, functional, and operational knowledge.

In support of the E3 and SM community, two NKO COPs have been developed: the EMC COP and the SM COP. The focus is on continuous learning, mutual exchange, and collaboration. These COPs also provide support to government civilians and contractors in the disciplines of E3 and SM.

- The EMC COP is sponsored by the Center for Surface Combat Systems (CSCS). The mission of this COP is to provide support for the NEC ET-1419 “EMC Technician.”



<https://wwwa.nko.navy.mil/portal/home>

Figure 2. Navy Knowledge Online url

- The SM COP is sponsored by the Center for Information Dominance (CID). The mission of the SM COP is to provide support to the NEC IT-2301 “Enlisted Frequency Manager” and the NEC IT-2302 “Joint Task Force (JTF) SM Master Level.”

NKO is one tool Navy leaders should use and encourage others to use. When supervisors have a new check-in, they should encourage the establishment of an NKO account. This is a good way to assist new members with personal and professional growth.

THE TRANSITION TO DRRS-N

The fleet began transitioning to DRRS-N on 1 October 2008. DRRS-N is a major shift in readiness thinking and reporting, moving the focus from reporting unit resources and training to assessing and managing force capabilities. Afloat units are receiving the DRRS-N hardware and software to facilitate the transition. Virtually all commander, Navy installation command shore stations, and regional commanders worldwide are already reporting in DRRS-N. Many other shore-based commands have begun the transition as well.

UP ALL ANCHORS, FULL SPEED AHEAD

The Navy is changing the basis for training development from a curriculum based on a sailor's rate to one based on NMETLs, joint mission essential task lists (JMETLs), and agency mission essential task lists (AMETLs). Each position on a Navy platform (e.g., ship, submarine, aircraft, or ashore command) will have a supporting Job Task Analysis/Job Analysis (JTA/JA) that will determine the training required for an individual to fill that position. An individual's skills, as defined in an individual's career path, will be compared against the position requirements.

The *Spectrum Management Manual, Naval Tactical Publication (NTP)-6* provides procedures for the effective execution of SM within the Navy and Marine Corps. NTP-6 was recently updated to include responsibilities for spectrum and E3 personnel. EMC can occur only when all phases of spectrum supportability,⁴ spectrum certification, frequency assignment, and E3 are understood and performed through effective task execution.

Our challenge is to ensure that SM and E3 NMET's requirements are appropriately included in the various JTA/JAs and in the training products' development, which supports these tasks and

the overall Joint/Navy missions. For web-based training (WBT) products, NAVSEA is committed to share E3/SM WBT materials within our communities and across services. To accomplish this, future NAVSEA contracts must meet DoD Shareable Content Object Reference Model (SCORM) requirements, which are a collection of standards and specifications for web-based e-Learning.

An effective training program must support the NWTs, which is based on mission, function, and tasks tied to personnel training requirements and maintained using a continuous improvement process (CIP). E3/SM NTSP stakeholders should, at a minimum, enroll in NKO at www.nko.navy.mil to investigate the world of possibilities. For example, E3 training is offered at the Center for Combat Systems (CSCS) Learning Site, Norfolk, Virginia, and additional information can be researched at the EMC Communities of Practice website. In addition, a wealth of spectrum information can be obtained from the SM COP website.

When the Navy is not fighting, it is training. When the Navy is fighting, it is training. The most important ingredient in the Navy's success is the talent, energy, dedication, skill, and courage of our sailors. Their growth and development is the highest priority of Navy leaders. The U.S. Navy is engaged in an enterprise-wide transformation of how it operates in an effort to improve and align its organizations, incorporate new technologies into Navy training, exploit opportunities available from the private sector, and develop a continuum of lifelong learning and personal and professional development for sailors. This transformation is helping to keep our Navy #1 in the world.

ACKNOWLEDGMENTS

Dr. Patricia Collins, Frank Capaci, and Brian Blackwelder (General Dynamics Information Technology); and Paulo Perini (Delta Resources Inc.) contributed to this article.

REFERENCES

1. DoDD 1322.18, *Military Training*, 3 September 2004 and CFFCINST 3501.3A, *Fleet Training Continuum*, 20 December 2006.
2. CFFCINST 3501.3A, *Fleet Training Continuum*, 20 December 2006.
3. DoDD 7730.65, *Department of Defense Readiness Reporting System (DRRS)*, 3 June 2002.
4. OPNAV 2400.20F, *Electromagnetic Environmental Effects (E3) and Spectrum Supportability Policy and Procedures*, 19 July 2007.



E3 – Electromagnetic Environmental Effects

LEADING

EDGE

Volume 7, Issue No. 1



FALLEN WARRIORS
*Here we honor those who died
while serving their country*



NSWCDD/MP-09/31

Statement A: Approved for public release; distribution is unlimited