

NAVAL RESEARCH LABORATORY

THE FACT BOOK

2012



the NAVY'S corporate laboratory

The NRL Fact Book is a reference source for information about the Naval Research Laboratory (NRL). It is updated and placed on NRL's Web site (<http://www.nrl.navy.mil>) annually. It is printed every other year. To provide additional information to the reader, a point of contact is listed for each activity.

NRL has a continuing need for physical scientists, mathematicians, engineers, and support personnel. Vacancies are filled without regard to age, race, creed, sex, or national origin. Information concerning current vacancies is furnished on request. Address all such inquiries to:

Human Resources Office
 Personnel Operations Branch (Code 1810)
 Naval Research Laboratory
 Washington, DC 20375-5320

<http://www.nrl.navy.mil>

Quick Reference Telephone Numbers

	NRL WASHINGTON	NRL- SSC	NRL- MONTEREY	NRL CBD	NRL VXS-1 Patuxent River
Hotline	(202) 767-6543	(202) 767-6543	(202) 767-6543	(202) 767-6543	(202) 767-6543
Personnel Locator	(202) 767-3200	(228) 688-3390	(831) 656-4763	(410) 257-4000	(301) 342-3751
DSN	297- or 754-	828	878	—	342
Direct-in-Dialing	767- or 404-	688	656	257	342
Public Affairs	(202) 767-2541	(228) 688-5328	(202) 767-2541	—	(202) 767-2541

Additional telephone numbers are listed on pages 138 and 139.



NRL

FACT

BOOK

NAVAL RESEARCH LABORATORY
WASHINGTON, DC 20375-5320

Contents

1	INTRODUCTION TO THE NAVAL RESEARCH LABORATORY
1	Mission
3	The Naval Research Laboratory in the Department of the Navy
4	NRL Functional Organization
5	Current Research
8	Major Research Capabilities and Facilities
14	NRL Sites and Facilities
15	EXECUTIVE DIRECTORATE
17	Executive Directorate - Commanding Officer and Director of Research
20	Executive Council
21	Research Advisory Committee
23	Office of Technology Transfer
24	Office of Program Administration and Policy Development
25	Office of Counsel
26	Institute for Nanoscience
28	Command Support Division
30	Military Support Division
32	Scientific Development Squadron ONE (VXS-1)
34	Laboratory for Autonomous Systems Research
36	Human Resources Office
39	BUSINESS OPERATIONS DIRECTORATE
41	Associate Director of Research for Business Operations
43	Contracting Division
45	Financial Management Division
47	Supply and Information Services Division
49	Research and Development Services Division
51	SYSTEMS DIRECTORATE
53	Associate Director of Research for Systems
55	Radar Division
57	Information Technology Division
59	Optical Sciences Division
61	Tactical Electronic Warfare Division
63	MATERIALS SCIENCE AND COMPONENT TECHNOLOGY DIRECTORATE
65	Associate Director of Research for Materials Science and Component Technology
67	Laboratories for Computational Physics and Fluid Dynamics
69	Chemistry Division
71	Materials Science and Technology Division
73	Plasma Physics Division
75	Electronics Science and Technology Division
77	Center for Bio/Molecular Science and Engineering

79	OCEAN AND ATMOSPHERIC SCIENCE AND TECHNOLOGY DIRECTORATE
81	Associate Director of Research for Ocean and Atmospheric Science and Technology
83	Office of Research Support Services (NRL-SSC)
85	Acoustics Division
87	Remote Sensing Division
89	Oceanography Division
91	Marine Geosciences Division
93	Marine Meteorology Division
95	Space Science Division
97	NAVAL CENTER FOR SPACE TECHNOLOGY
99	Director of Naval Center for Space Technology
101	Space Systems Development Department
103	Spacecraft Engineering Department
105	TECHNICAL OUTPUT, FISCAL, AND PERSONNEL INFORMATION
106	Technical Output
108	Fiscal
111	Personnel Information
112	PROFESSIONAL DEVELOPMENT
113	Programs for NRL Employees
115	Programs for Non-NRL Employees
117	GENERAL INFORMATION
118	Maps
125	Key Personnel



Introduction to the Naval Research Laboratory

Mission

To conduct a broadly based multidisciplinary program of scientific research and advanced technological development directed toward maritime applications of new and improved materials, techniques, equipment, systems, and ocean, atmospheric, and space sciences and related technologies.

The Naval Research Laboratory

- Provides primary in-house research for the physical, engineering, space, and environmental sciences;
- Provides broadly based exploratory and advanced development programs in response to identified and anticipated DON needs;
- Provides broad multidisciplinary support to the Naval Warfare Centers;
- Provides space and space systems technology development and support; and
- Assumes responsibility as the Navy's corporate laboratory.



The Naval Research Laboratory is located in Washington, DC, on the east bank of the Potomac River.



The NRL Marine Meteorology Division is located in Monterey, California (NRL-MRY).



The Naval Research Laboratory Detachment is located at Stennis Space Center, Bay St. Louis, Mississippi (NRL-SSC).

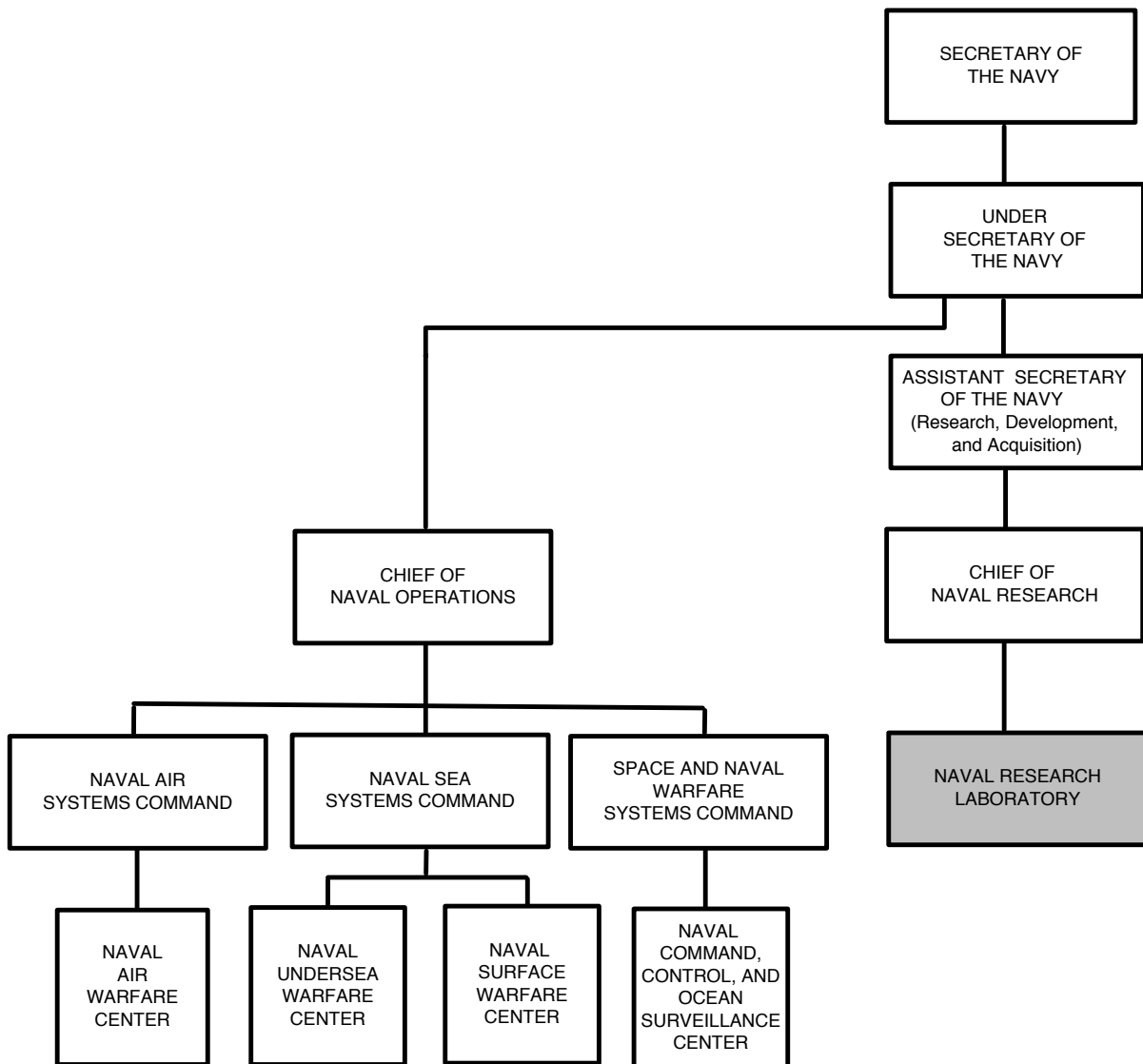



The Naval Research Laboratory in the Department of the Navy

The Naval Research Laboratory is the Department of the Navy's corporate laboratory; it is under the command of the Chief of Naval Research. As the corporate laboratory of the Navy, NRL is the principal in-house component in the Office of Naval Research's (ONR) effort to meet its science and technology responsibilities.

NRL has had a long and fruitful relationship with industry as a collaborator, contractor, and most recently in Cooperative Research and Development Agreements (CRADAs). NRL values this linkage and continues to develop it.

NRL is an important link in the Navy Research, Development, and Acquisition (RD&A) chain. Through NRL, the Navy has direct ties with sources of fundamental ideas in industry and the academic community throughout the world and provides an effective coupling point to the R&D chain for ONR.

NRL Functional Organization

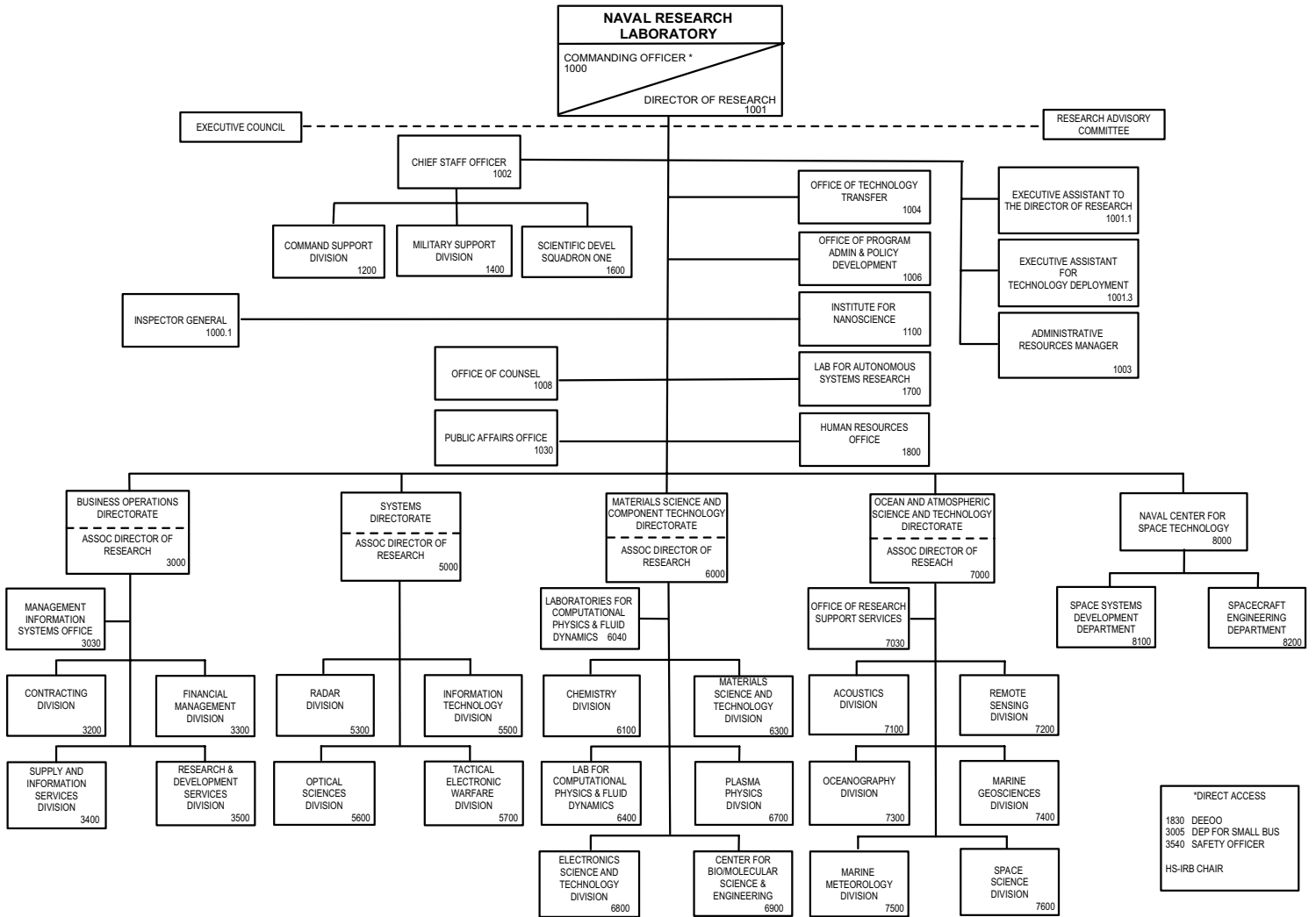

Current Research

The following areas represent broad fields of NRL research. Under each, more specific topics that are being investigated for the benefit of the Navy and other sponsoring organizations are listed. Some details of this work are given in the *NRL Review*, published annually. More specific details are published in reports on individual projects provided to sponsors and/or presented as papers for professional societies or their journals.

Advanced Radio, Optical, and IR Sensors

- Advanced optical sensors
- EM/EO/meteorological/oceanographic sensors
- Satellite meteorology
- Precise space tracking
- Radio/infrared astronomy
- Infrared sensors and phenomenology
- UV sensors and middle atmosphere research
- Image processing
- VLBI/astrometry
- Optical interferometry
- Imaging spectrometry
- Liquid crystal technology

Autonomous Systems

- Algorithms for control of autonomous systems
- Cognitive robotics
- Human-robot interaction
- Perception hardware and algorithms
- High-level reasoning algorithms
- Machine learning and adaptive algorithms
- Sensors for autonomous systems
- Power and energy for autonomous systems
- Networking and communications for mobile systems
- Swarm behaviors
- Test and evaluation of autonomous systems

Computer Science and Artificial Intelligence

- Standard computer hardware, development environments, operating systems, and run-time support software
- Methods of specifying, developing, documenting, and maintaining software
- Human-computer interaction
- Intelligent systems for resource allocation, signal identification, operational planning, target classification, and robotics
- Parallel scientific libraries
- Algorithms for massively parallel systems
- Digital progressive HDTV for scientific visualization
- Adaptive systems: software and devices
- Advanced computer networking
- Simulation management software for networked high performance computers
- Interactive 3D visualization tools and applications
- Real-time parallel processing
- Scalable, parallel computing
- Petaflop computing, globally distributed file systems, terabit-per-second networking

Directed Energy Technology

- High-energy lasers
- Laser propagation
- Solid-state and fiber lasers
- High-power microwave sources
- RAM accelerators
- Pulse detonation engines
- Charged-particle devices
- Pulse power
- DE effects

Electronic Electro-optical Device Technology

- Integrated optics
- Radiation-hardened electronics
- Nanotechnology
- Microelectronics
- Microwave and millimeter-wave technology
- Hydrogen masers for GPS
- Aperture syntheses
- Electric field coupling
- Vacuum electronics
- Focal plane arrays
- Infrared sensors
- Radiation effects and satellite survivability
- Molecular engineering

Electronic Warfare

- EW/C2W/IW systems and technology
- COMINT/SIGINT technology
- EW decision aids and planning/control systems
- Intercept receivers, signal processing, and identification systems
- Passive direction finders
- Decoys and offboard countermeasures (RF and IR)
- Expendable autonomous vehicles/UAVs
- Repeaters/jammers and EO/IR active countermeasures and techniques
- Platform signature measurement and management
- Threat and EW systems computer modeling and simulations
- Visualization
- Hardware-in-the-loop and flyable ASM simulators
- Missile warning infrared countermeasures
- RF environment simulators
- EO/IR multispectral/hyperspectral surveillance

Enhanced Maintainability, Reliability, and Survivability Technology

- Coatings
- Friction/wear reduction
- Water additives and cleaners

- Fire safety
- Laser hardening
- Satellite survivability
- Corrosion control
- Automation for reduced manning
- Radiation effects
- Mobility fuels
- Chemical and biological sensors
- Environmental compliance

Environmental Effects on Naval Systems

- Meteorological effects on communications
- Meteorological effects on weapons, sensors, and platform performance
- Air quality in confined spaces
- Electromagnetic background in space
- Solar and geomagnetic activity
- Magnetospheric and space plasma effects
- Nonlinear science
- Ionospheric behavior
- Oceanographic effects on weapons, sensors, and platforms
- EM, EO, and acoustic system performance/ optimization
- Environmental hazard assessment
- Contaminant transport
- Biosensors
- Microbially induced corrosion

Imaging Research/Systems

- Remotely sensed signatures analysis
- Real-time signal and image processing algorithms/ systems
- Image data compression methodology
- Image fusion
- Automatic target recognition
- Scene/sensor noise characterization
- Image enhancement/noise reduction
- Scene classification techniques
- Radar and laser imaging systems studies
- Coherent/incoherent imaging sensor exploitation
- Remote sensing simulation
- Hyperspectral imaging
- Microwave polarimetry

Information Technology

- High-performance, all-optical networking
- Antijam communication links
- Next-generation, signaled optical network architectures
- Integrated voice and data
- Information security (INFOSEC)
- Voice processing
- High performance computing
- High performance communications
- Requirements specification and analysis
- Real-time computing
- Wireless mobile networking
- Behavior detection
- Machine learning

- Information filtering and fusion
- Integrated internet protocol (IP) and asynchronous transfer mode (ATM) multicasting
- Reliable multicasting
- Wireless networking with directional antennas
- Sensor networking
- Communication network simulation
- Bandwidth management (quality of service)
- High assurance software
- Distributed network-based battle management
- High performance computing supporting uniform and nonuniform memory access with single and multithreaded architectures
- Distributed, secure, and mobile information infrastructures
- Simulation-based virtual reality
- High-end, progressive HDTV imagery processing and distribution
- Defensive information warfare
- Virtual reality/mobile augmented reality
- 3D multimodal interaction
- Model integration (physical, environmental, biological, psychological) for simulation
- Command decision support
- Data fusion

Marine Geosciences

- Marine seismology, including propagation and noise measurement
- Geoacoustic modeling in support of acoustic performance prediction
- Geomagnetic modeling in support of nonacoustic system performance prediction
- Static potential field measurement and analysis (gravity and magnetic) in support of navigation and geodesy
- Geotechnology/sediment dynamics affecting mine warfare and mine countermeasures
- Foreshore sediment transport
- Geospatial information, including advanced seafloor mapping, imaging systems, and innovative object-oriented digital mapping models, techniques, and databases

Materials

- Superconductivity
- Magnetism
- Biological materials
- Materials processing
- Advanced alloy systems
- Solid free-form fabrication
- Environmental effects
- Energetic materials/explosives
- Aerogels and underdense materials
- Nanoscale materials
- Nondestructive evaluation
- Ceramics and composite materials
- Thin film synthesis and processing
- Electronic and piezoelectric ceramics
- Thermoelectric materials

Active materials and smart structures
Computational material science
Paints and coatings
Flammability
Chemical/biological materials
Spintronic materials and half metals
Biomimetic materials
Multifunctional materials
Power and energy
Synthetic biology

Meteorology

Global, theater, tactical-scale, and on-scene numerical weather prediction
Data assimilation and physical initialization
Atmospheric predictability and adaptive observations
Adjoint applications
Marine boundary layer characterization
Air/sea interaction; process studies
Coupled air/ocean/land model development
Tropical cyclone forecasting aids
Satellite data interpretation and application
Aerosol transport modeling
Meteorological applications of artificial intelligence and expert systems
On-scene environmental support system development/nowcasting
Tactical database development and applications
Meteorological tactical decision aids
Meteorological simulation and visualization

Ocean Acoustics

Underwater acoustics, including propagation, noise, and reverberation
Fiber-optic acoustic sensor development
Deep ocean and shallow water environmental acoustic characterization
Undersea warfare system performance modeling, unifying the environment, acoustics, and signal processing
Target reflection, diffraction, and scattering
Acoustic simulations
Tactical decision aids
Sonar transducers
Dynamic ocean acoustic modeling

Oceanography

Oceanographic instrumentation
Open ocean, littoral, polar, and nearshore oceanographic forecasting
Shallow water oceanographic effects on operations
Modeling, sensors, and data fusion
Bio-optical and fine-scale physical processes
Oceanographic simulation and visualization
Coastal scene generation
Waves, tides, and surf prediction
Coupled model development

Coastal ocean characterization
Oceanographic decision aids
Global, theater, and tactical-scale modeling
Remote sensing of oceanographic parameters
Satellite image analysis

Space Systems and Technology

Space systems architectures and requirements
Advanced payloads and optical communications
Controllers, processors, signal processing, and VLSI
Precision orbit estimation
Onboard autonomous navigation
Satellite ground station engineering and implementation
Tactical communication systems
Spacecraft antenna systems
Launch and on-orbit support
Precise Time and Time Interval (PTTI) technology
Atomic time/frequency standards/instrumentation
Passive and active ranging techniques
Design, fabrication, and testing of spacecraft and hardware
Structural and thermal analysis
Attitude determination and control systems
Reaction control
Propulsion systems
Navigation, tracking, and orbit dynamics
Spaceborne robotics applications

Surveillance and Sensor Technology

Point defense technology
Imaging radars
Surveillance radars
Multifunction RF systems
High-power millimeter-wave radar
Target classification/identification
Airborne geophysical studies
Fiber-optic sensor technology
Undersea target detection/classification
EO/IR multispectral/hyperspectral detection and classification
Sonar transducers
Electromagnetic sensors, gamma ray to RF wavelengths
SQUID for magnetic field detection
Low observables technology
Ultrawideband technology
Interferometric imagery
Microsensor system
Digital framing reconnaissance canvas
Biologically based sensors
Digital radars and processors

Undersea Technology

Autonomous vehicles
Bathymetric technology
Anechoic coatings
Acoustic holography
Unmanned undersea vehicle dynamics
Weapons launch

Major Research Capabilities and Facilities

(Listed alphabetically by organizational unit)

Acoustics Division (Code 7100)

Laboratory Measurements

- One-million-gallon, vibration-isolated underwater acoustic holographic/3D laser vibrometer facility for studying structural acoustic phenomena
- Large, sandy-bottom, acoustic holographic pool facility for investigating echo characteristics of underwater buried/near-bottom targets and sediment acoustics
- In-air structural acoustics facility with high spatial density near-field acoustic holography and 3D laser vibrometry for diagnosing large structures, including aircraft interiors and rocket payload fairings
- Salt water acoustic tank (20 ft by 20 ft by 10 ft deep) with environmental control and substantial optical access for studying the acoustics of bubbly media, acoustic metamaterials, and laser induced sound
- Micro-Nanostructure Dynamics Laboratory to study the structural dynamics and performance of high Q oscillators and other micromechanical systems using laser Doppler vibrometers, super resolution nearfield scanning optical microscope, and low temperature calorimeter
- Model Fabrication Laboratory to fabricate rough topographical surfaces in various materials for acoustic scattering and propagation studies and measurements.
- Sonomagnetic Laboratory with doubly insulated Faraday cage for conducting experiments to measure weak electromagnetic fields generated by mechanical/acoustic vibrations of a conducting medium in an arbitrary magnetic field

Seagoing Assets

- Acoustic arrays (towed/moored/suspended)
- 64-channel broadband source-receiver array with time-reversal mirror functionality over a frequency band of 500 to 3500 Hz
- High-powered sound sources and source arrays
- Autonomous acoustic sources
- Acoustic communications array and data acquisition buoy
- Portable, ocean-deployable synthetic aperture acoustic measurement system (100-meter rail with precise positioning)
- Containerized, seagoing multichannel data acquisition system
- High-speed, maneuverable towed body with MK-50 and synthetic aperture sonars to measure high frequency scattering and coherence

Center for Bio/Molecular Science and Engineering (Code 6900)

- Optical equipment
 - Confocal microscope
 - Raman microscope

- UV-visible absorption spectrophotometers
- Transmission electron microscope
- Scanning electron microscope
- Microscope/atomic force microscope
- Nanosight (nanoparticle tracking analysis)

Analytical instruments

- Gas chromatography mass spectrometer
- HPLC
- LC/MS/MS system
- FluoroMax-3 spectrofluorometer
- Titration workstation

General facilities

- X-ray scattering
- Cold room for storage and preparation
- High-speed ultracentrifuges
- Inert atmosphere dry box
- NMR
- FTIR
- Ellipsometer
- Dynamic mechanical analyzer
- Differential scanning calorimeter
- Circular dichroism
- Minimill injection mold machine
- Multi RF centrifuge
- Perkin Elmer BioChip Arrayer I
- Freeze-dry system
- Affymetrix Gene Chip system
- Surface plasmon resonance (SPR)
- Isothermal calorimeter

Chemistry Division (Code 6100)

- Synthesis/processing facilities
 - Paint formulation and coating
 - Functional polymers/elastomers/composites
 - Nanotubes/Nanofibers
 - Surface modification
 - Thin film deposition/etching with in situ control
- Marine Corrosion Facility (at Key West, FL)
- Fire/Damage Control Test Facility (at Mobile, AL)
- Characterization facilities
 - General-purpose chemical analysis/trace analysis
 - Surface diagnostics
 - Nanometer scale composition/structure/properties
 - Magnetic resonance NDI
 - Tribology
 - Polymer structure/function/dynamics
- Special-purpose capability
 - Environmental monitoring/remediation
 - Combustion and fire research
 - Alternate and petroleum-derived fuels
 - Trace explosive detection test beds
 - Trace vapor generation and detection test beds
- Simulation/modeling
- Synchrotron radiation beam lines (at NSLS, Brookhaven, NY)
- Pressurized test chambers (small, medium, large)

Electronics Science and Technology Division (Code 6800)

Nano- and microelectronics characterization and processing facilities
Electron-beam nanowriter
High-resolution transmission electron microscope
Scanning tunneling microscopy and electro-optical analysis
Material growth facilities including bulk crystal growth, molecular beam epitaxy, organometallic chemical vapor deposition, and atomic layer deposition
Optical and electrical characterization of materials
Electronic testing and analysis facilities
Cathode fabrication and characterization laboratory
Millimeter-wave vacuum electronics fabrication facility
Femtosecond laser facility
Solar cell characterization facility
Power electronics materials characterization and device processing facilities

Information Technology Division (Code 5500)

Extended Spectrum Experimentation Laboratory
Robotics and Autonomous Systems Laboratory
Immersive Simulation Laboratory
Warfighter Human-Systems Integration Laboratory
Audio Laboratory
Mobile and Dynamic Network Laboratory
Integrated Communications Technology Test Lab
General Electronics Environmental Test Facility
Key Management Laboratory
Crypto Technology Laboratory
Navy Cyber Defense Research Laboratory
Communications Security (COMSEC) Laboratory
Navy Shipboard Communications Testbed
Behavior Detection Laboratory
Virtual Reality Laboratory
Service Oriented Architecture Laboratory
Distributed Simulation Laboratory
Motion Imagery Laboratory
Laboratory for Large Data Research
Affiliated Resource Center for High Performance Computing
Ruth H. Hooker Research Library

Institute for Nanoscience (Code 1100)

Clean room (5000 sq ft), quiet (4000 sq ft), and ultra-quiet (1000 sq ft) laboratories
35 dB and 25 dB acoustically isolated zones
20°C ± 0.5°C and 0.1°C controlled temperature zones
Vibration isolation
Vertical (mm, pp) <0.1 @ 70–500 Hz
Horizontal (mm, pp) <0.1 @ 70–500 Hz
Clean electrical power, free from SCR spikes and other interferences, and < ±10% voltage change
<0.5 mG at 60 Hz EMI

45 ± 5% relative humidity
Class 100 clean room
Source of water meeting ASTM D5127 spec. Type E1.2
Clean Room Major Equipment
Monitoring system (toxic gas, hazmat, temperature)
Laminar flow wet benches for localized Class 1/10 ambient in clean room
Air purification unit to remove local organic contamination
DI water system
Wire bonder
E-beam writer with active vibration control system
Scanning electron microscope
Atomic force microscope
Metallurgical optical microscopes
Surface profiler
Mask aligners (2, 1, and 0.2 μm)
Electron beam evaporation system
Low pressure chemical vapor deposition (LPCVD) system
Magnetron sputter deposition system
Reactive ion etching systems
Dual-beam focused ion beam workstation
Optical pattern generating system
Laser micromachining system
Plasma-enhanced chemical vapor deposition (PECVD) system
Plasma-enhanced atomic layer deposition system
Chlorine reactive ion etching system
Other Major Equipment
Transmission electron microscope
UHV multi-tip scanning tunneling microscope/nanomanipulator

Laboratories for Computational Physics and Fluid Dynamics (Code 6040)

1120-core x86 cluster
(3) 64-core SGI Altix systems
184-core x86 cluster
256-core SGI ICE
256-processor Opteron cluster
More than sixty SGI, Apple, and Intel workstations
Three-quarter-terabyte RAID disk storage systems
All computers and workstations have network connections to NICENET and ATDnet allowing access to the NRL CCS facilities (including the DoD HPC resources) and many other computer resources both internal and external to NRL

Laboratory for Autonomous Systems Research (Code 1700)

Prototyping High Bay: (150 ft by 75 ft by 30 ft), contains real-time motion capture system, directional environmental sounds, GPS repeater and simulator
Four human-systems interaction labs contain eye trackers and multiuser, multitouch monitors
Littoral High Bay with 45 ft by 25 ft by 5.5 ft deep pool with 16-channel wave generator and slope that allows simulation of littoral environments; multiple sediment

tanks (from 5 ft to 16 ft); GPS repeater and simulator; portable tank 4 ft by 36 ft
 Desert High Bay with a 40 ft by 14 ft area of sand 2.5 ft deep, and 18 ft high rock walls; high speed fans and variable lighting
 Tropical High Bay, a 60 ft by 40 ft greenhouse, contains a re-creation of a southeast Asian rain forest with native plants; nominal 80 degrees temperature and 80% humidity; can generate rain events up to 6 in. per hour; Rainforest contains waterfall, stream, and pond
 Outdoor test range is a 1/3 acre highland forest with a waterfall, stream and pond, and terrain of differing difficulty including large bolder structures and earthen berms
 Sensor lab contains environmental chambers (small and walk-in) with maximum temperature range of -50°F to 375°F, relative humidity from 10% to 95% and for smaller chamber, barometric pressure of -9000 feet to 100,000 feet; lab also contains various fume hoods, biosafety cabinet, anechoic chamber, vapor generators, and other specialized equipment
 Power and energy lab contains specialized equipment including a battery dry room, glove box, isolation room, and fume hoods

Marine Geosciences Division (Code 7400)

Airborne gravimetry, magnetics, and topographic measurements suite coupled with differential GPS yielding position accuracies of <1.0 meter
 100 and 500 kHz sidescan sonar with 2–12 kHz chirp profiler and Cs magnetometer for seafloor characterization/imaging and shallow subbottom profiling
 Deep-towed acoustic geophysical system operating at 220–1000 Hz characterizes subseafloor structure including gas clathrate accumulations and dissociation of methane hydrates
 Acoustic seafloor classification system operating at 8–50 kHz provides underway, real-time prediction of sediment type and physical properties
 Seafloor probes for measuring sediment pore water pressures, permeability, electrical resistivity, acoustic compressional and shear wave velocities and attenuations, and dynamic penetration resistance
 100 and 300 kV transmission electron microscopes with environmental cell for study of sediment fabric, especially impact of organic matter
 Map data formatting facility compresses map information onto CD-ROM media for masters for use in aircraft digital moving map systems
 Comprehensive geotechnical and geoacoustics laboratory capability
 Airborne electromagnetic (AEM) bathymetry system
 Ocean bottom magnetometer system
 3D, multispectral, subbottom swath imaging system
 Ocean bottom seismographs (OBS)
 In situ sediment acoustic measurement system (IS-SAMS)

Instrumented mine shapes to measure hydrodynamics of free-fall in the water column, dynamics of deceleration in seafloor sediments, and rates and depths of scour burial
 Hydrothermal plume imaging data acquisition and analysis system
 Integrated digital databases analysis and display system for bathymetric, meteorological, oceanographic, geoacoustic, and acoustic data
 Stereometric video image processing system for use in foreshore morphology measurement
 Sediment gas-content sampler
 Acoustic tomographic probes for surf zone sands and gassy muds
 Computed tomography (CT) system and real-time radiography unit with a 0–225 keV @ 0–1 mA micro-focus X-ray tube and a 225 mm image intensifier
 Patented Geospatial Information Data Base (GIDB™) for rapidly accessing disparate geospatial content on the Internet. This is the most extensive interconnection of geospatial data that exists. <http://dmap.nrlssc.navy.mil>
 Human-centered display design through the application of human factors principles in the design of geospatial displays (e.g., analysis of clutter in electronic displays)
 GPS-based survey vehicles and equipment to measure foreshore and nearshore bathymetry (camera towers, jet ski, and push cart)
 Geospatial visualization lab for rapid 2D and 3D graphic and physical visualization, analysis, and prototyping
 Small oscillatory flow tunnel to observe sediment dynamics under forcing from waves and currents
 Tomographic particle image velocimetry system for three-dimensional volumetric velocity measurements of fluid flow

Marine Meteorology Division (Code 7500)

The USGODAE Data Server (Global Ocean Data Assimilation Experiment) for collection and distribution of near-real-time METOC data and higher-level products from Navy and other providers to the global ocean and atmospheric research community
 AN/SMQ-11 shipboard antenna system for retrieving polar-orbiting satellite data
 Geostationary satellite data direct readout and polar-orbiting satellite data processing center
 Supercomputer for numerical weather prediction systems development
 Master Environmental Library (MEL) implemented on superworkstations for archiving and distributing real-time and historical atmosphere/ocean databases
 Bergen Data Center for extensive file serving on disks and research data backup/archival capability on tapes
 Data visualization center for developing shipboard briefing tools, displaying observations and model output, and integrating meteorological parameters

into tactical simulations
Classified radar and satellite data processing facility
Two Mobile Atmospheric Aerosol and Radiation Characterization Observatories (MAARCO)
Technical research library

Materials Science and Technology Division (Code 6300)

Hot isostatic press
Cold isostatic press
High-energy dispersive X-ray analytical system
Electron microprobe, SEM, SAM, and STEM systems
Quantitative metallography
Computer-controlled multiaxial loading and SCC measurement systems
Computer-aided experimental stress analysis
Crystallite orientation distribution function (CODF)
Class 1000 clean room; processing metallic film
Elevated temperature and structural characterization laboratory
Metallic film deposition systems
Magnetometry
Cryogenic facilities
High-field magnets
High-resolution analytical electron microscope
Isothermal heat treating facility
Vacuum arc melting facility
Vacuum induction melting facility
3 MeV tandem Van de Graaff accelerator
200 keV ion-implantation facility
Precision colorimeters
Polymer synthesis and characterization
Microwave device test facility
Excimer laser film deposition facility
Bomen infrared spectrometer facility
Diffuse light scattering facility
Femtosecond laser facility
Surface characterization facility
Accelerator mass spectrometry facility
Carbon-14 dating facility
Laminated object manufacturing system
Thermal analysis characterization suite (TGA/DSC/DMA/DEA/rheometer)
Dielectric characterization facility
Composites processing autoclave
3D ESPI strain measurement system
Biomechanical surrogate fabrication facility

Oceanography Division (Code 7300)

Towed sensor and advanced microstructure profiler systems for studying upper ocean fine and microstructure
Integrated absorption cavity and optical profiler systems for studying ocean optical characteristics
Self-contained bottom-mounted upward-looking acoustic profilers for measuring ocean variability
Acoustic Doppler profiler for determining ocean currents while under way
Remotely operated underwater vehicle (ROV)
Bottom-mounted acoustic Doppler profilers

Towed hyperspectral optical array
SCI processing facility
Satellite receiving stations for AVHRR, MODIS, and DMSP ocean color processing facility
Environmental scanning electron microscope, confocal laser scanning microscope, and the new Inspect S low vacuum scanning electron microscope for detailed studies of biocorrosion in naval materials
Real-time Ocean Observations and Forecast Facility for monitoring and tracking of ocean physical and bio-optical conditions
Slocum Electric Gliders for performing wide-area ocean surveys of temperature, salinity, and optical characteristics
SCANFISH MKII, a towed undulating vehicle system, designed for collecting 3D TS profile data of the water column
Bottom-mounted Shallow water Environmental Profiler in Trawl-safe Real-time configuration (SEPTR) for measuring temperature, salinity, and optical parameters in addition to current profiles and pressure

Optical Sciences Division (Code 5600)

Optical probes laboratory to study viscoelastic, structural, and transport properties of molecular systems
Short-pulse excitation apparatus for kinetic mechanisms investigations
IR laser facility for optical characterization of semiconductors
Facilities for synthesis and characterization of optical glass compositions and for the fabrication of optical fibers
Silica and IR fluoride/chalcogenide fiber fabrication facilities
Environmental testing of fiber sensors (acoustic, magnetic, electric field, etc.)
Laser diode pumped solid-state lasers
Mid-IR, low-phonon crystal growth facility
Infrared countermeasure techniques laboratory
Mobile, high-precision optical tracker
EO/IR technology/systems modeling and simulation capabilities
Field-qualified EO/IR measurement devices
Focal plane array evaluation facility
Facilities for fabricating and testing integrated optical devices
Panchromatic and multi- and hyperspectral digital imaging processing facilities
NRL P-3 aircraft sensor pallet
Airborne EO/IR and radar sensors
VNIR through SWIR hyperspectral systems
VNIR, MWIR, and LWIR high-resolution systems
Wideband SAR systems
RF and laser data links
High-speed, high-power photodetector characterization
Communication link characterization to >100 Gbps
RF phase noise, noise figure, and network analysis
Ultrahigh-speed A/O converters

Plasma Physics Division (Code 6700)

Mercury, 6 MV, 360 kA, magnetically insulated inductive voltage adder
Gamble II, 1 MV, 1 MA pulsed power generator
HAWK, 1 MA inductive storage facility
Table-Top Terawatt (T³) laser system
Table-Top Ti: Sapphire Femtosecond Laser (TFL) systems (10 Hz and 1 kHz)
NIKE krypton fluoride laser facility
Space Physics Simulation Chamber
Plasma Applications Laboratory
Microwave facility for processing of advanced materials (2.45, 35, 83, and 60–120 GHz)
ELECTRA, test bed for high-rep 5 Hz KrF laser
Railgun Materials Testing Facility
Directed Energy Physics Facility
SWOrRD laser facility

Radar Division (Code 5300)

Shipboard radar research and development test beds:
AMRFC test bed
AN/SPS-49A(V)1
Airborne research radar facility, APS-137D(V)5
High-power 94 GHz radar system
Ultrahigh-resolution radar system (microwave microscope)
Radar signature calculation facility
Electromagnetic numerical computation facility
Compact range antenna measurement laboratory and nearfield scanner
Electronic protection (EP) and adaptive pulse compression (APC) test bed
Electronic computer-aided design facility
Microwave and RF instrumentation laboratory
Functional materials electromagnetic analysis laboratory
High-bandwidth, high-capacity data recording system
High frequency (HF) multiple-input-multiple-output (MIMO) test bed

Remote Sensing Division (Code 7200)

Ground-based water vapor millimeter-wave spectrometer (WVMS)
SAR processing facility
SCI processing facility
SEALAB
SAIL
Hyperspectral imaging, sensors, and processing
Optical remote sensing calibration lab/facility
Navy Prototype Optical Interferometer (NPOI)
NRL/NRAO 74 MHz Very Large Array
Free surface hydrodynamics laboratory (including a 10 m wave tank)
WindSat processing facility
Volume imaging lidar system
Aerosol and field measurement facility
NRL RP-3A aircraft sensors

Airborne polarimetric microwave imaging radiometer (APMIR)
Airborne lidar
Millimeter-wave imager
Interferometric synthetic aperture radar (InSAR)
Flight-level meteorological sensors
Visible/near infrared (VNIR) hyperspectral imaging systems
Mid-wave infrared (MWIR) indium antimonide (InSb) hyperspectral imaging system
Long-wave infrared (LWIR) quantum well IR photodetector (QWIP) imaging system

Research and Development Services Division (Code 3500)

Military construction
Research support engineering
Planning
Full range of facility contracting, including construction, architect/engineering services, facilities support, and reserved parking
Transportation
Telephone services
Maintenance and repair of buildings, grounds, and communication and alarm systems
Shops for machining, sheet metal, welding, and plating
Occupational safety and health
Environmental
Health physics

Spacecraft Engineering Department (Code 8200)

Chambers:
Thermal-vacuum
Acoustic reverberation
Large, tapered horn, RF anechoic chamber
EMI/EMC testing chamber
Facilities:
Spacecraft high-reliability electronic and electrical rework facility
Spacecraft electronic systems integration and test facility
Radio frequency (RF) system development facility
RF microcircuit fabrication clean room facility
Large tapered horn RF anechoic chamber facility
Frequency sources laboratory
Shock and vibration test
Clean rooms (multiple classes and sizes)
Spacecraft fabrication and assembly
Fuels testing
Autoclave
Space robotics laboratory
Proximity operations testbed
CAD/CAM
Propulsion system welding

Static loads test
Star tracker characterization
Spacecraft spin balance
Modal analysis
Computational astrodynamics simulation and visualization

Space Science Division (Code 7600)

Development and test facilities for satellite, sounding rocket, and balloon instruments, to perform solar terrestrial, astrophysical, astronomical, solar, upper/middle atmospheric, and space environment sensing
Infrared Test Facility (IRTF)
Solar Coronagraph Optical Test Chamber (SCOTCH)
Vacuum Ultraviolet Calibration Facility (VUCF)
Gamma Ray Imaging Laboratory (GRIL)
Doppler Asymmetric Spatial Heterodyne Spectroscopy (DASH) balloon instrument
Very high angular Resolution Imaging Spectrometer (VERIS) sounding rocket instrument
Remote Atmospheric and Ionospheric Detection System (RAIDS) International Space Station instrument
Extreme Ultraviolet Imaging Spectrometer (EIS) satellite instrument
Sun Earth Connection Coronal and Heliospheric Investigation (SECCHI) satellite instrument suite
Solar Orbiter Heliospheric Imager (SoloHI) satellite instrument
Wide-field Imager (WISPR) satellite instrument
Compact Coronagraph (CCOR) satellite instrument
Special Sensor Ultraviolet Limb Imager (SSULI) satellite instrument
Spatial Heterodyne Imager for Mesospheric Radicals (SHIMMER) satellite instrument
Atmospheric Neutral Density Experiment (ANDE) microsatellite
Extensive computer-assisted data manipulation, interpretive, and theoretical capabilities for space science instrumentation operations, data imaging, and modeling
SECCHI Payload Operations Center (POC)
Fermi Gamma-ray Space Telescope (formerly GLAST) Science Analysis Center (SAC)
Simulation of radiation detection and systems in space and terrestrial environments (SWORD & SMART)
Mountain Wave Forecast Model (MWFM)
Advanced Level Physics High Altitude extension of the Navy Operational Global Atmospheric Prediction System (NOGAPS-ALPHA)
Synthetic Scene Generation Model (SSGM)
Integrating the Sun-Earth System for the Operational Environment (ISES-OE)

Space Systems Development Department (Code 8100)

Payload test facility and processor development laboratory
Laser communications and electro-optics laboratories

Tactical Technology Development Laboratory (TTDL)
Precision oscillator (clock) test facility
RF payload development laboratory with anechoic chamber
Precision high-frequency RF compact range anechoic chamber facility
Transportable ground station development, assembly, and test facility
Multiplatform FPGA/ASIC/VLSI development laboratory
Satellite telemetry, tracking, and satellite control at Blossom Point, MD
L/C/S/X-band fixed antenna resources
Connectivity to the Air Force Satellite Control Network (AFSCN)
Pomomkey field site: large antenna, space communications, and research facility
Midway Research Center space communications and research facility
Optical telescope facility

Tactical Electronic Warfare Division (Code 5700)

Visualization display room
Transportable step frequency radar
Vehicle development laboratory
Offboard test platform
Compact antenna range facility
Isolation measurement chamber facility
RFCM techniques development chamber facility
Low-power anechoic chamber
High-power microwave research facility
Electro-optics mobile laboratory
Infrared-electro-optical calibration and characterization laboratory
Infrared missile simulator and simulator development laboratory
Secure supercomputing facility
CBD/Tilghman Island IR field evaluation facility
Ultrashort pulse laser effects research and analysis laboratory
Central Target Simulator facility
Flying Electronic Warfare laboratory
High-power RF explosive laboratory
Classified material lay-up facility
Classified computing facilities
RF measurement laboratory
Wet chemistry laboratory
Ultra-near-field test facility
RF and millimeter-wave laboratory
Optical laboratory
Paint room
Secure laboratories for classified projects

NRL Sites and Facilities

SITE	ACREAGE		BUILDINGS/ STRUCTURES
	LAND OWNED/LEASED	EASEMENT/ LICENSE-PERMIT	
District of Columbia NRL and Joint Base Anacostia-Bolling*	131/0	0/10.13	93/30
Virginia Midway Research Center Quantico*	162/0	0/0	7/11
Maryland NRL Scientific Development Squadron One (VXS-1), NAS Patuxent River*	Tenant		
Chesapeake Bay Section and Dock Facility Chesapeake Beach*	168/0	.6/.02	47/77
Multiple Research Site Tilghman Island*	3/0	0/0	3/3
Free Space Antenna Range Pomonkey*	141/0	0/0	10/10
Blossom Point Satellite Tracking and Command Station Blossom Point*	0/0	0/265	22/23
Florida Marine Corrosion Facility Key West	Tenant		
California NRL Monterey Monterey*	Tenant		
Mississippi Stennis Space Center Bay St. Louis*	Tenant		
Alabama Ex-USS <i>Shadwell</i> (LSD-15) Mobile Bay Decommissioned 457-ft vessel used for fire research	Tenant		

PROPERTY

Land: 824 acres	Buildings:	Replacement Costs:
	RDT&E 3,183,094 ft ²	Buildings Plant Replacement
	Administrative 249,121 ft ²	Value (PRV) ¹ \$1,252.0 million
	Other 266,749 ft ²	Equipment Costs ² \$523.7 million

¹Per DON Facilities Asset Data System standard cost factors.

²NRL Accountable Property Acquisition Costs

*See maps in the General Information section (page 131).



**Executive
Directorate**

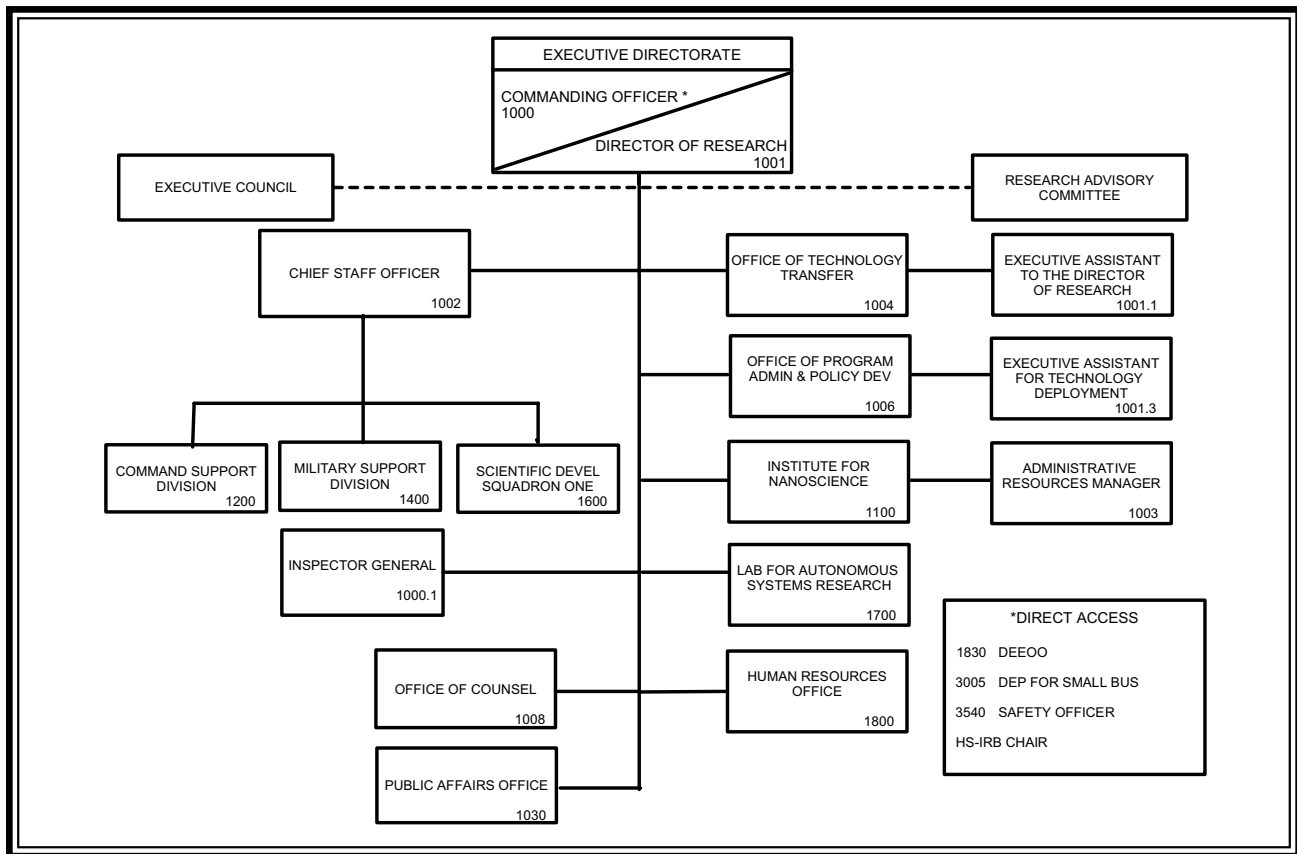

Key Personnel

Title	Code
Commanding Officer	1000
Director of Research	1001
Executive Assistant to the Director of Research	1001.1
Head, Strategic Workforce Planning	1001.2
Executive Assistant for Technology Deployment	1001.3
NRL Historian	1001.15
Chief Staff Officer / Inspector General	1002 / 1000.1
Command Management Review	1000.12
Head, Office of Technology Transfer	1004
Head, Office of Program Administration and Policy Development	1006
Head, Office of Counsel	1008
Head, Public Affairs Office	1030
Director, Institute for Nanoscience	1100
Head, Command Support Division	1200
Head, Military Support Division	1400
Commanding Officer, Scientific Development Squadron One (VXS-1)	1600
Director, Laboratory for Autonomous Systems Research	1700
Director, Human Resources Office	1800
Deputy Equal Employment Opportunity Officer	1830
Deputy for Small Business	3005
Head, Safety Branch	3540

EXECUTIVE DIRECTORATE

Code 1000 and Code 1001

The Commanding Officer (Code 1000) and the Director of Research (Code 1001) share executive responsibility for the management of the Naval Research Laboratory. In accordance with Navy requirements, the Commanding Officer is responsible for the overall management of the Laboratory and exercises the usual functions of command including compliance with legal and regulatory requirements, liaison with other military activities, and the general supervision of the quality, timeliness, and effectiveness of the technical work and of the support services.

The Commanding Officer delegates line authority and assigns responsibility to the Director of Research for the Laboratory's technical program, its planning, conduct, and staffing; evaluation of the technical competence of personnel; liaison with the scientific community; selection of subordinate technical personnel; exchange of technical information; and the effective execution of the NRL mission.

Within the limits of Navy regulations, the Commanding Officer and the Director of Research share authority and responsibility for the internal management of the Laboratory. The Commanding Officer retains all authority and responsibility specifically assigned to him by higher authority.

The mission of the Laboratory is carried out by three science and technology directorates and the Naval Center for Space Technology, supported by the Business Operations Directorate and the Executive Directorate. In addition, the Laboratory's operating staffs provide assistance in their special fields to the Commanding Officer and to the Director of Research. The operating staffs are listed on the following pages of this publication.

Commanding Officer

Captain Anthony J. Ferrari is a native of Queens, New York, and was raised in the New York/New Jersey area. Upon graduation from Delran High School in 1982, he joined the Navy and attended the Naval Academy Preparatory School in Newport, Rhode Island. In 1983, he received an appointment to the United States Naval Academy and graduated in 1987 with a B.S. degree in oceanography and physics. Upon commissioning, he attended undergraduate flight training and was winged as a Naval Flight Officer in 1988. His next set of orders sent him to Whidbey Island, Washington, and Fleet Replacement Squadron 128 (VA-128), where he completed Bombardier/Navigator training in 1990 and joined the “Milestones” of VA-196. During his tour with VA-196, he accumulated over 1,000 hours in the A-6 Intruder and flew missions in support of Operation Desert Shield.

In 1993, he was selected for U.S. Naval Test Pilot School and graduated in the summer of 1994 with class 105. As a Flight Test Officer, he was assigned to VX-23 in Patuxent River, Maryland, and worked on various test projects supporting Carrier Aviation and Weapons testing. When the A-6 Intruder was faithfully retired, he transitioned to the F-14 community and served on the staff of CVW-17 as the Air Wing Strike Operations Officer, completing two Mediterranean deployments from 1997 to 1999. Following a brief training syllabus at VF-101, he reported to the “World Famous Pukin’ Dogs” (VF-143) and served as the Safety and Operations Officer.

Upon completion of his department head tour, he was then assigned as the Officer in Charge and Chief Operational Test Director of the VX-9 detachment, Point Mugu, California. This tour was followed by a second tour in Patuxent River, joining NAVAIR as the PMA-241 class desk officer, and principal deputy Program Manager. During this tour, he transitioned to the Aviation Engineering Duty Officer (AEDO) community, was selected as an Acquisition Professional (AP), and received an M.S. degree in systems engineering at Johns Hopkins University.

After leaving NAVAIR, he was assigned as the Naval Aviation Depot Requirements Officer, Fleet Readiness Division (OPNAV N43) in the Office of the Chief of Naval Operations at Washington, DC. This was followed by a tour with the Naval Personnel Command as the Head Detailer for the Aerospace Engineering and Maintenance Communities.

Selected for Major Command in 2008, he proudly served as the Deputy Director and Director of PMR-51, the Navy’s Low Observable/Counter Low Observable Technology, Policy and Advanced Project office from December 2008 through August 2012.

Captain Ferrari has been awarded the Legion of Merit, Meritorious Service Medal (four awards), Navy and Marine Corps Commendation Medal (four awards) and the Navy and Marine Corps Achievement Medal (three awards), in addition to numerous campaign and unit awards.



Director of Research

Dr. John A. Montgomery joined the Naval Research Laboratory in 1968 as a research physicist in the Advanced Techniques Branch of the Electronic Warfare Division, where he conducted research on a wide range of Electronic Warfare (EW) topics. In 1980, he was selected to head the Off-Board Countermeasures Branch. In May 1985, he was appointed to the Senior Executive Service and was selected as Superintendent of the Tactical Electronic Warfare Division. He has been responsible for numerous systems that have been developed/ approved for operational use by the Navy and other services. He has had great impact through the application of advanced technologies to solve unusual or severe operational deficiencies noted during world crises, most recently in Afghanistan, Iraq, and for Homeland Defense and in the Pacific theater. Dr. Montgomery has accumulated 43 years of civilian service to-date at the Naval Research Laboratory.

Dr. Montgomery received the Department of Defense Distinguished Civilian Service Award in 2001. He was recognized by the Department of the Navy Distinguished Civilian Service Award in 1999 and by the Department of the Navy Meritorious Civilian Service Award in 1986. As a member of the Senior Executive Service, he received the Presidential Rank Award of Distinguished Executive in 1991 and again in 2002, and the Presidential Rank Award of Meritorious Executive in 1988, 1999 and again in 2007. He also received the 1997 Dr. Arthur E. Bisson Prize for Naval Technology Achievement, awarded by the Chief of Naval Research in 1998. Further, he has received the Association of Old Crows (Electronic Defense Association) Joint Services Award in 1993. He was an NRL Edison Scholar, and is a member of Sigma Xi. He served as the U.S. National Leader of The Technical Cooperation Program's multinational Group on Electronic Warfare from 1987 to 2002, and served as its Executive Chairman. In 2006, Dr. Montgomery received the Laboratory Director of the Year award from the Federal Laboratory Consortium for Technology Transfer, and in 2011, he received the Roger W. Jones Award for Executive Leadership from American University's School of Public Affairs.

Dr. Montgomery received his bachelor's of science degree in physics from North Texas State University in 1967 and his master's degree, also in physics, in 1969. He received his PhD in physics from the Catholic University of America in 1982. As Director of Research at the Naval Research Laboratory, Dr. Montgomery oversees research and development programs with expenditures of approximately \$1.2 billion per year.



Executive Council



The Executive Council consists of executive, management, and administrative personnel. Executive Council members include the following:

- Commanding Officer, Chairperson
- Director of Research
- Executive Assistant to the Director of Research
- Associate Directors of Research
- Chief Staff Officer
- Director, Naval Center for Space Technology
- Associate Director, Naval Center for Space Technology
- Heads of Divisions
- Director, Laboratories for Computational Physics and Fluid Dynamics
- Director, Center for Bio/Molecular Science and Engineering
- Director, Human Resources Office
- Public Affairs Officer
- Deputy Equal Employment Opportunity Officer
- Administrative Resources Manager
- Head, Office of Program Administration and Policy Development
- Safety Officer
- Head, Office of Counsel
- Head, Office of Technology Transfer
- Head, Management Information Systems Staff
- Head, Office of Research Support Services
- Representative, Administrative Advisory Council
- Director, Institute for Nanoscience
- Director, Laboratory for Autonomous Systems Research

Research Advisory Committee



The Research Advisory Committee advises the Commanding Officer and the Director of Research on scientific programs and the administration of the Laboratory. The committee assists in planning the long-range scientific program, coordinating the scientific work, reviewing the budget, accepting or modifying problems, considering personnel actions, and initiating such studies as may be necessary or desirable. The membership consists of the following:

- Director of Research, Chairperson
- Commanding Officer
- Associate Directors of Research
- Chief Staff Officer (Observer)

Chief Staff Officer/Inspector General Code 1002/1000.1



CAPT K. SZCZUBLEWSKI, USN

The Chief Staff Officer serves as the Deputy to the Commanding Officer and acts for the Commanding Officer in his absence. The Command Support Division (Code 1200), the Military Support Division (Code 1400), and the Scientific Development Squadron One (VSX-1) (NAS Patuxent River, MD, Code 1600) report directly to the Chief Staff Officer. When directed, the Laboratory's Inspector General investigates, inspects, and/or inquires into matters that affect the operation and efficiency of NRL. These matters include but are not limited to: effectiveness, efficiency, and economy; management practices; and fraud, waste, and abuse. He serves as principal advisor to the Commanding Officer on all inspection matters and audits and is the principal point of contact and liaison with all agencies outside NRL.

Public Affairs Officer Code 1030



MR. R.L. THOMPSON

The Public Affairs Officer (PAO) advises the Commanding Officer and Director of Research on public affairs matters, including external and internal relations and community outreach, and serves as the Commanding Officer's principal assistant in the area of public affairs. To do this, the PAO plans and directs a program of public information dissemination on official NRL activities. The PAO coordinates responses to requests from the news media and the public for unclassified information or materials dealing with the Laboratory, coordinates participation in community relations activities, and directs the internal information programs. The PAO is also responsible for coordinating all actions within the Laboratory that respond to requirements of the Freedom of Information Act (FOIA).

Deputy Equal Employment Opportunity Officer Code 1830



MS. L.L. HILL

The Deputy Equal Employment Opportunity Officer (DEEEO) is the EEO program manager and the advisor to the Commanding Officer on all EEO matters. The DEEEO manages the discrimination complaint process and directs the Laboratory's affirmative action plans and special emphasis programs (Federal Women's, Hispanic Employment, African American Employment, Asian-Pacific Islanders, American Indian Employment, Individuals with Disabilities, including Disabled Veterans). The DEEEO recruits quality candidates for those areas when underrepresentation exists. Duties also include reviewing, coordinating, and monitoring implementation of EEO policies and developing local guidance, directives, and implementation procedures for the EEO programs.

Office of Technology Transfer

Code 1004

Basic Responsibilities

The Technology Transfer Office (TTO) is responsible for NRL's implementation of the Federal Technology Transfer Act of 1986 (Public Law 99-502). The law requires the transfer of Government innovative technologies to industry for commercialization as products and services for public benefit. TTO negotiates Cooperative Research and Development Agreements (CRADAs) under which NRL investigators collaborate with investigators from industry, academia, state or local governments, or other Federal agencies to develop NRL technologies for government and/or commercial use. It markets NRL's patented inventions, negotiates patent license agreements under which the Navy grants a licensee the right to make, use, and sell NRL inventions (in exchange for receiving licensing fees and a percentage of sales), and enforces licenses to assure diligence in commercialization efforts.

Personnel: 6 full-time civilian; 1 SCEP student, 1 STEP student

Key Personnel

Title	Code
Head, Technology Transfer	1004
Sr. Licensing Associate	1004
Sr. Licensing Associate	1004
Social Media Marketing Associate	1004
Licensing Associate	1004
Management Analyst	1004
Administrative Assistant (SCEP)	1004
Administrative Assistant (STEP)	1004

Point of contact: Code 1004, (202) 767-7229

Office of Program Administration and Policy Development

Code 1006

Basic Responsibilities

The Office of Program Administration and Policy Development provides managerial, technical, and administrative support to the Director of Research (DOR) in such areas as program and policy development, intra-Navy and inter-Service Science and Technology (S&T) program coordination; liaison with other Navy, DoD, and government activities on matters of mutual concern; and support to the Executive Directorate in planning and directing NRL's S&T (6.1, 6.2) program. Specific functions include: monitoring and providing background information on technical and policy matters that come under the purview of the DOR; representing NRL, ONR, and/or the Navy on tri-Service or DoD-wide coordination matters; performing special studies or chairing ad hoc study groups regarding program decisions or policy positions; performing special studies involving major NRL programs and resource issues; providing administrative support in the areas of personnel, budget, facilities, equipment, and security; providing executive management information and analyses for various aspects of the S&T program effort; coordinating VIP visits to NRL; managing the NRL directives system; administering the NRL response to Congressional requests; maintaining the NRL R&D achievements file; developing the S&T guidance for monitoring and reporting the NRL S&T program; administering NRL's various postdoctoral fellowship programs; and managing the Facility Modernization Program.

Personnel: 14 full-time civilian

Key Personnel

Title	Code
Head, Office of Program Administration and Policy Development	1006
Head, Program Administration Staff	1006.1
VIP Coordinator/Protocol Officer	1006.2
Head, Executive Management & Policy Development Staff	1006.3
Directives	1006.31
Head, NRL Facilities Staff	1006.4
Special Assistant	1006.6

Point of contact: Code 1006.2, (202) 767-3370

Office of Counsel

Code 1008

Basic Responsibilities

The Office of Counsel is responsible for providing legal services to NRL's management in all areas of general, administrative, intellectual property, and technology transfer law. The Office reviews all procurement-related actions; reviews NRL scientific papers prior to publication; prepares patent applications and prosecutes the applications through the Patent and Trademark Office; defends against contract protests, other contract litigation, and personnel cases; and advises on other legal matters relating to technology transfer, personnel, fiscal, and environmental law.

NRL Counsel also serves as legal advisor to the Commanding Officer and Director of Research.

Personnel: 30 full-time civilian

Key Personnel

Title	Code
Head, Office of Counsel	1008
Associate Counsel/General Law	1008.1
Associate Counsel/Intellectual Property	1008.2
Associate Counsel/SSC Legal Matters	1008.3

Point of contact: Code 1008.1, (202) 767-7606

Institute for Nanoscience

Code 1100 Staff Activity Areas

- Interdisciplinary nanoscience that enables:
 - Low-power, high-speed electronics
 - Lightweight, high-strength materials
 - Highly sensitive molecular sensors
 - Efficient energy generation and storage



NRL researchers working in the Class 100 clean room in the Institute for Nanoscience.

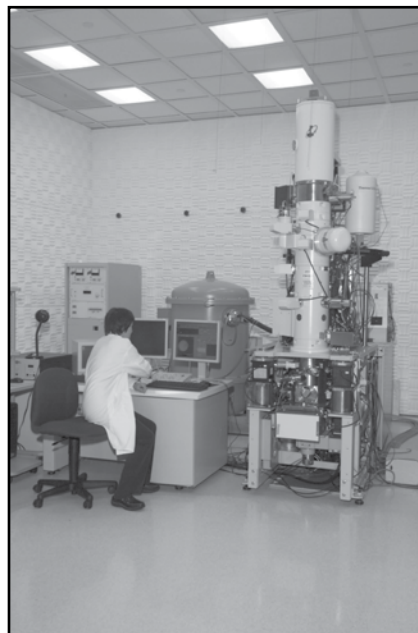

Transmission electron microscope located in one of the Institute for Nanoscience's environmentally controlled laboratories.

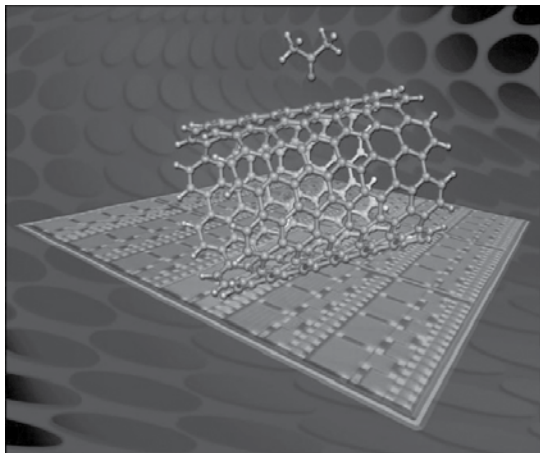

Wafer of carbon nanotube chemical sensors fabricated in the Institute for Nanoscience clean room.

Code 1100

Basic Responsibilities

The Institute for Nanoscience has two primary responsibilities: to administer an interdisciplinary research program in nanoscience and to provide NRL scientists with high-quality laboratory space and state-of-the-art nanofabrication facilities.

The mission of the research program is to conduct highly innovative, interdisciplinary research at the intersections of the fields of materials, electronics, and biology in the nanometer size domain. The Institute exploits the broad multidisciplinary character of NRL to bring together scientists and engineers with disparate training and backgrounds to attack common goals at the intersection of their respective fields at this length scale. The Institute's S&T programs provide the Navy and DoD with scientific leadership in this complex, emerging area and help to identify opportunities for advances in future defense technology.

The Institute also operates a nanoscience research building containing nanofabrication facilities and environmentally controlled measurement laboratories. The central core of the building, a 5000 sq ft Class 100 clean room, has been outfitted with the newest tools to permit nanofabrication, measurement, and testing of devices. In addition to the clean room facility, the building also contains 5000 square feet of controlled-environment laboratory space, which is available to NRL researchers whose experiments are sufficiently demanding to require this space. There are 12 of these laboratories within the building. They provide shielding from electromagnetic interference, and very low floor vibration and acoustic levels. Eight of the laboratories control the temperature to within ± 0.5 °C and four to within ± 0.1 °C.

Personnel: 3.5 full-time civilian

Key Personnel

Title	Code
Director, Institute for Nanoscience	1100
Position Assistant	1100
Facilities Manager	1100
Facilities Manager	1100

Point of Contact: Code 1100, (202) 767-1804

Command Support Division

Code 1200 Staff Activity Areas

- Security



Incoming visitor reception area

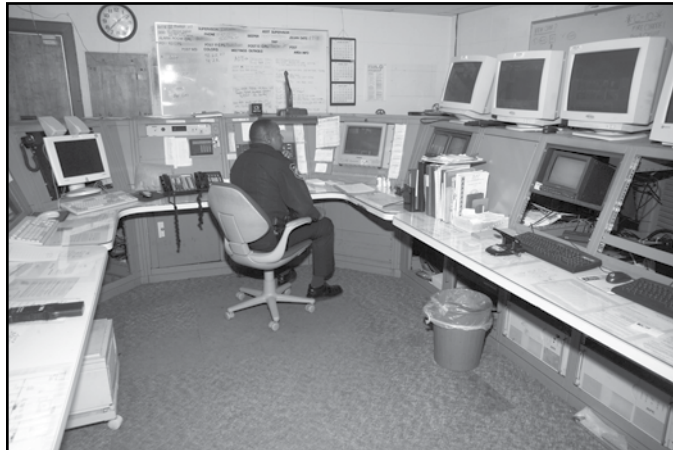

Security monitoring

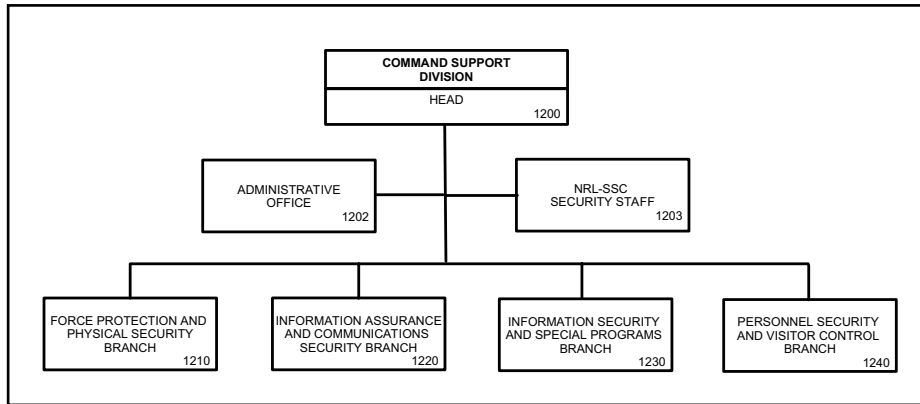

Basic Responsibilities

The Command Support Division is responsible for NRL security policy, management, and enforcement. The Division Head is the NRL Security Manager. The primary areas of security are: information assurance, information security, personnel security, industrial security, classification management, public release, foreign disclosure, physical security, force protection, antiterrorism, operations security, special security programs, and communications security. Provides security education across all security disciplines. Conducts local inspections for compliance with current internal and external policies. Provides advice and guidance to senior NRL management concerning the security posture of the Command. Provides administrative budget support to the Military Support Division (Code 1400) and Scientific Development Squadron One (VXS-1, Code 1600).

Personnel: 50 full-time civilian

Key Personnel

Title	Code
Head, Command Support Division	1200
Administrative Officer	1202
Head, Stennis Space Center Security Staff	1203
Head, Force Protection and Physical Security Branch	1210
Head, Information Assurance and Communications Security Branch	1220
Head, Information Security and Special Programs Branch	1230
Head, Personnel Security and Visitor Control Branch	1240

Point of contact: Code 1202, (202) 767-6987

Military Support Division

Code 1400 Staff Activity Areas

- Operations
- Administrative Operations



P-3 airborne research platform



Administration

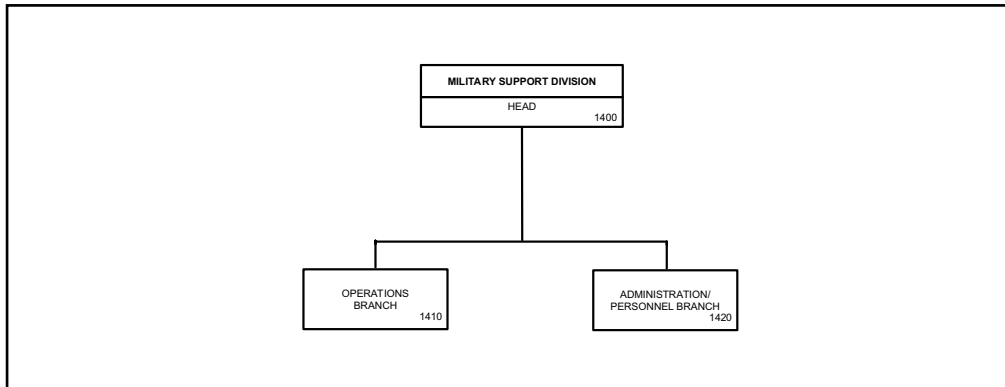

Basic Responsibilities

The Military Support Division provides military operational and administrative services to NRL.

The Operations Branch assists NRL research directorates in planning and executing project flight missions, develops deployment schedules and military operational and training objectives, and coordinates the Research Reserve Program within NRL.

The Military Administration Branch is responsible for the coordination and efficient functioning of all military administrative operations for NRL (including site detachments). These duties specifically include: personnel actions, maintenance of personnel records, performance evaluations, awards and training; advising the Chief Staff Officer on manpower matters and organization issues; and preparing and administering the military operational budget.

Personnel: 1 full-time civilian; 7 military

Key Personnel

Title	Code
Head, Military Support Division	1400
Project Officer	1410
Project Officer	1410
Project Officer	1410
Administrative Officer	1420

Point of contact: Code 1420, (202) 767-7632

Scientific Development Squadron ONE (VXS-1)

Code 1600 Staff Activity Areas

- Operations
- Administrative Operations
- Aircraft Maintenance
- Safety/NATOPS



VXS-1 maintains two RC-12 aircraft dedicated to airborne research. They are smaller, more cost-efficient alternatives to the P-3 Orion. Each aircraft is outfitted with a research electrical load center and has a roll-on roll-off capability which enables it to be equipped with project stations. The RC-12s can support a broad spectrum of project configurations.



Aircraft maintenance



P-3 airborne research platform



Scientific Development Squadron One hangar

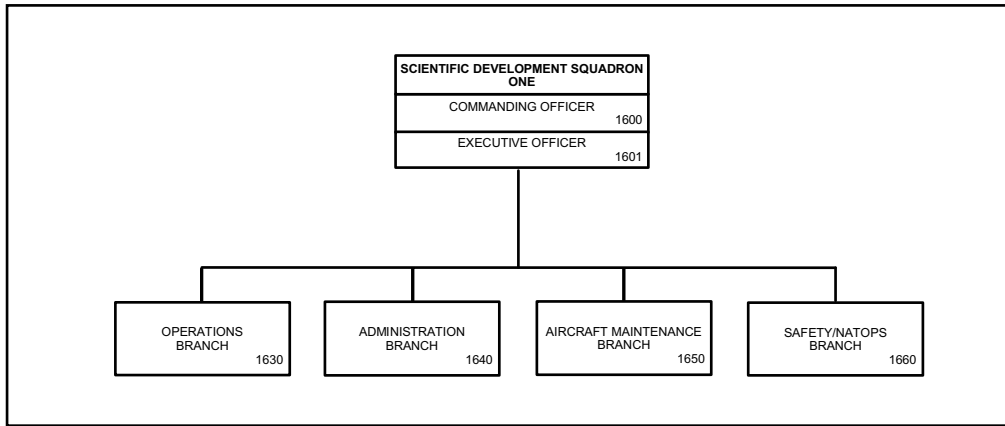

Basic Responsibilities

The Scientific Development Squadron ONE (VXS-1) located at NAS Patuxent River, Maryland, operates and maintains five uniquely configured P-3 Orion aircraft and two C-12 aircraft. The men and women of the squadron provide the Naval Research Laboratory with airborne research platforms, conducting flights worldwide in support of a broad spectrum of projects and experiments. These include magnetic variation mapping, hydroacoustic research, bathymetry, electronic countermeasures, gravity mapping, and radar research. The squadron annually logs approximately 1000 flight hours, and in its 47 years, Scientific Development Squadron ONE (VXS-1) has amassed 69,000 hours of mishap-free flying.

Personnel: 3 full-time civilian; 70 military; 9 full-time contractors

Key Personnel

Title	Code
Commanding Officer, VXS-1	1600
Executive Officer	1601
Senior Enlisted Advisor	1600.2
Executive Secretary	1600.4
Operations Officer	1630
Administrative Officer / Public Affairs Officer	1640
Maintenance Officer	1650
Assistant Maintenance Officer	1650.1
Maintenance / Material Control Officer	1650.2
Safety / NATOPS Officer	1660

Point of contact: Code 1600.4, (301) 342-3526; DSN 342-3526

Laboratory for Autonomous Systems Research

Code 1700 Staff Activity Areas

Multidisciplinary research, development, and integration in autonomous systems, including:

- Software for intelligent autonomy
- Novel human-systems interaction technology
- Mobility and platforms
- Sensor systems
- Power and energy systems
- Networking and communications
- Trust and assurance



The Laboratory for Autonomous Systems Research integrates S&T components into research prototype systems.

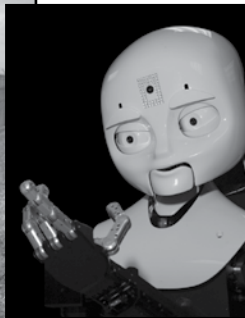

Because autonomous systems are not just vehicles, the building contains a number of human-system interaction labs to develop automated decision support tools and address critical communications and network issues.

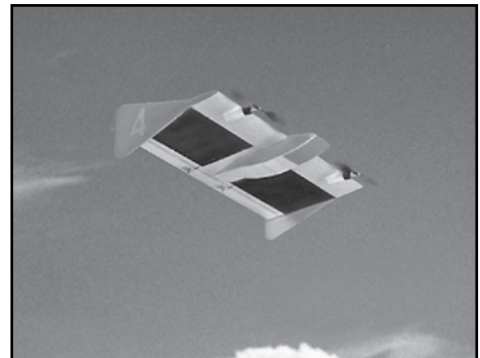

The Reconfigurable High Bay allows operation of small air vehicles as well as ground vehicles.

Code 1700

Basic Responsibilities

The Laboratory for Autonomous Systems Research provides specialized facilities to support highly innovative, interdisciplinary research in autonomous systems, including software for intelligent autonomy, sensor systems, power and energy systems, human-systems interaction, networking and communications, and platforms and mobility. The Laboratory capitalizes on the broad multidisciplinary character of NRL, bringing together scientists and engineers with disparate training and backgrounds to advance the state of the art in autonomous systems at the intersection of their respective fields. The Laboratory provides unique facilities and simulated environments (littoral, desert, tropical) and instrumented reconfigurable high bay spaces to support integration of science and technology components into research prototype systems. The objective of the laboratory is to enable Naval and DoD scientific leadership in this complex, emerging area and to identify opportunities for advances in future defense technology.

The facility includes a Reconfigurable Prototyping High Bay that allows real-time, accurate tracking of many entities (vehicles and humans) for experimental ground truth. Small UAVs and ground vehicles can simultaneously operate within the large high bay, which is viewable from four adjacent Human-System Interaction labs. The Tropical High Bay emulates a rainforest with appropriate terrain and plants, and includes flowing water features. An outdoor Highland Forest provides an additional forest environment, and also includes interesting water and terrain features. The Desert High Bay provides a simulated desert environment featuring a sand pit, natural rock walls, and appropriate lighting and wind. The Littoral High Bay provides a simulated coastal environment featuring sediment tanks, large pool with a sloping floor, and small flow tanks. In addition to the environmental high bays, the facility also has a Power and Energy Laboratory, a Sensor Laboratory, and a mechanical and electrical shop.

The facility is open to use by all NRL scientists contributing to the science and technology of autonomous systems and will host many NRL scientists as needed.

Personnel: 1.5 full-time civilian

Key Personnel

Title	Code
Director, Laboratory for Autonomous Systems Research	1700
Facilities Manager	1700

Point of contact: Code 1700, (202) 767-2684

Human Resources Office

Code 1800 Staff Activity Areas

- Personnel Operations (Staffing and Classification)
- Employee Relations
- Employee Development
- Equal Employment Opportunity and Manpower
- Compensation, Reports, and Demonstration Project
- Information Technology and Reports



Diversity and Employee Recognition Branch



Personnel Operations Branch



Employee Relations Branch



Employee Development and Management Branch

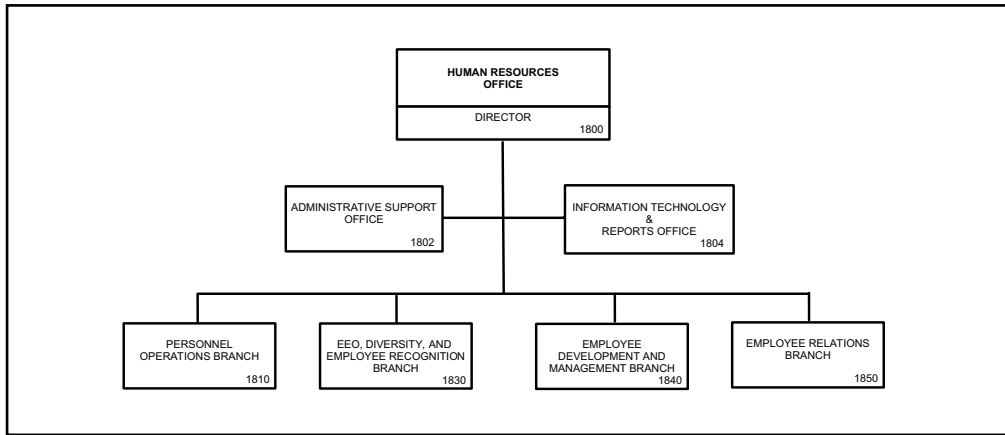

Basic Responsibilities

The Human Resources Office (HRO) provides civilian personnel, manpower, and Equal Employment Opportunity (EEO) services to the Naval Research Laboratory. The Human Resources Program provides the full range of operating civilian personnel management in the staffing and placement, position classification, employee relations, labor relations, employee development, EEO functional areas, manpower management, and morale, welfare, and recreation programs.

The HRO at NRL's main site in Washington, DC, services approximately 2,500 employees and provides a centralized capability to perform managerial, service, and advisory functions in support of field office operations. These include issuing policy and procedural directives; developing, designing, and maintaining automated systems; and monitoring and evaluating product effectiveness to develop and maintain efficient, cost-effective, service-oriented methods.

Personnel: 30 full-time civilian

Key Personnel

Title	Code
Director, Human Resources Office	1800
Administrative Officer	1802
Head, Information Technology and Reports Office	1804
Head, Personnel Operations Branch	1810
Head, EEO, Diversity, and Employee Recognition Branch	1830
Head, Employee Development and Management Branch	1840
Head, Employee Relations Branch	1850

Point of contact: Code 1802, (202) 404-2797

Ruth H. Hooker Research Library

Code 5596

Basic Responsibilities

NRL's Ruth H. Hooker Research Library supports NRL and ONR scientists in conducting their research by making a comprehensive collection of the most relevant scholarly information available and useable; by providing direct reference and research support; by capturing and organizing the NRL research portfolio; and by creating, customizing, and deploying a state-of-the-art digital library. Traditional library resources include extensive technical report, book, and journal collections dating back to the 1800s housed within a centrally located research facility that is staffed by subject specialists and information professionals. The collections include 44,000 books; 80,000 digital books; 80,000 bound historical journal volumes; more than 3,500 current journal subscriptions; and approximately 2 million technical reports in paper, microfiche, or digital format (classified and unclassified). Research Library staff members provide advanced information consulting; literature searches against all major online databases including classified databases; circulation of materials from the collection including classified literature up to the Secret level; and retrieval of articles, reports, proceedings, or documents through our interlibrary loan and document delivery network. The digital library provides desktop access to thousands of journals, books, proceedings, reports, databases, and reference sources.

Personnel: 21 full-time civilian

Key Personnel

Title	Code
Chief Librarian	5596
Head, Research Reports and Bibliography	5596.3
Library IT Director	5596.2

Point of contact: Code 5596, (202) 767-2357

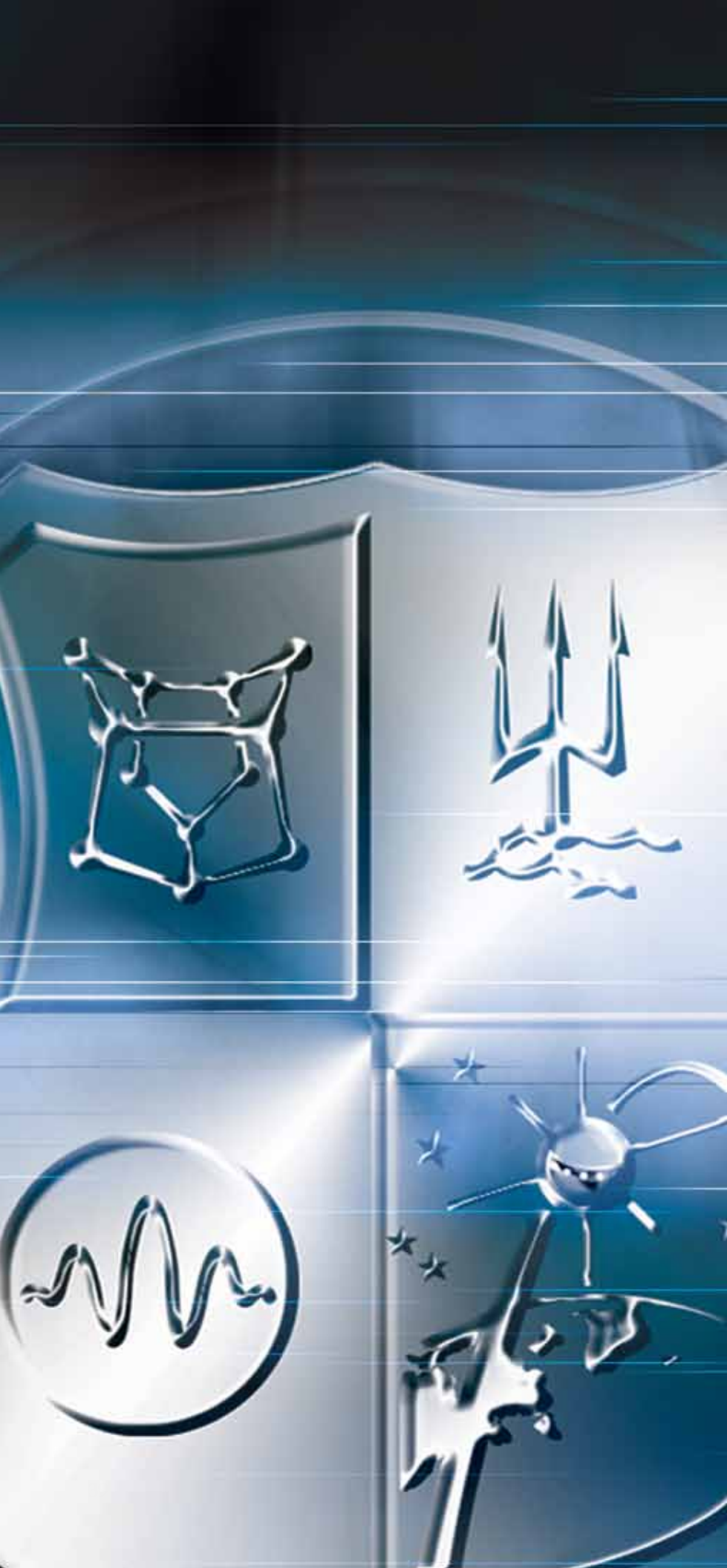

**Business
Operations
Directorate**

BUSINESS OPERATIONS DIRECTORATE

Code 3000

The Business Operations Directorate provides executive management, policy development, and program administration for business programs needed to support the activities of the scientific directorates. This support is in the areas of financial management, supply management, technical information services, contracting, research and development services, and management information systems support.

Associate Director of Research for Business Operations



Mr. D.K. Therning was born in Modesto, California. He graduated from Washington State University with a bachelor's degree in finance in 1983 and earned a master's degree in business administration from George Mason University in 1993. Mr. Therning has accumulated extensive experience in the financial business management of research, development, test, and evaluation (RDT&E) activities within the Department of the Navy (DON) beginning at the Naval Weapons Center, China Lake, California, where he served as a budget analyst in the Public Works Department and then in the Weapons Department. In 1984, he became the Financial Management Advisor to the Ordnance Systems Department. In 1985, under the auspices of

the Naval Scientist Training and Exchange Program, he was selected for a one-year assignment in the Office of the Director of Naval Laboratories (DNL), Washington, DC. He remained on the DNL staff as a budget analyst until 1987, when he was appointed Budget Officer of the DNL's seven Navy Industrial Fund R&D laboratories.

As the DON reorganized the R&D laboratories and T&E activities, Mr. Therning oversaw the financial reorganization of the DNL labs with other activities into the Naval warfare centers. Upon the disestablishment of DNL, Mr. Therning remained in the Space and Naval Warfare Systems Command as the Director of the Defense Business Operations Fund (DBOF) Resources Management Division, with collateral duty as the Financial Manager of the Naval Command, Control, and Ocean Surveillance Center (NCCOSC). During this time, he managed the conversion of nine appropriated fund engineering activities to DBOF and the financial consolidation of these activities with NCCOSC.

In 1995, Mr. Therning served as Head of the Revolving Funds Branch of the Office of the Assistant Secretary of the Navy (Financial Management and Controller), where he was responsible for the budget formulation and execution processes of all DON DBOF activities, which includes the RDT&E activities, shipyards, aviation depots, ordnance centers, and supply centers.

Mr. Therning was appointed Head, Financial Management Division/Comptroller of NRL in July 1996. In October 1996, in addition to leading the Financial Management Division, he assumed responsibilities for the Management Information Systems office. In January 1999, as an additional duty to his role as Comptroller, Mr. Therning was appointed to the newly established position of Deputy Associate Director of Research for Business Operations to assist in the management and administration of the Business Operations Directorate.

Mr. Therning was Acting Associate Director of Research for Business Operations from April 1999 until March 2000, when he was appointed the Associate Director of Research for Business Operations.

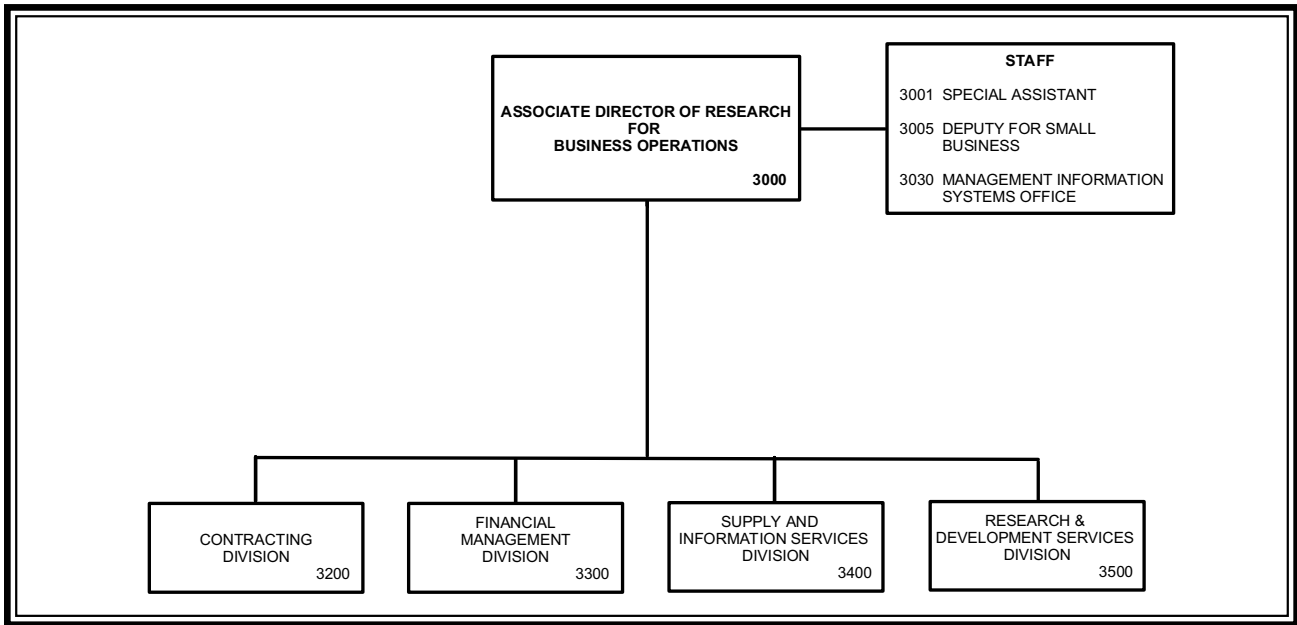

Key Personnel

Title	Code
Associate Director of Research for Business Operations	3000
Special Assistant	3001
Deputy for Small Business	3005
Head, Management Information Systems Office	3030
Head, Contracting Division	3200
Head, Financial Management Division	3300
Head, Supply and Information Services Division	3400
Director, Research and Development Services Division	3500

Point of contact: Code 3000A, (202) 404-7461

Contracting Division

Code 3200 Staff Activity Areas

- Advance Acquisition Planning
- Acquisition Strategies
- Acquisition Training
- Contract Negotiations
- Contractual Execution
- Contract Administration
- Acquisition Policy Interpretation and Implementation



Customers are greeted at the receptionist station.



Contracting personnel attend training session.



Procurement Technician reviews contract file.

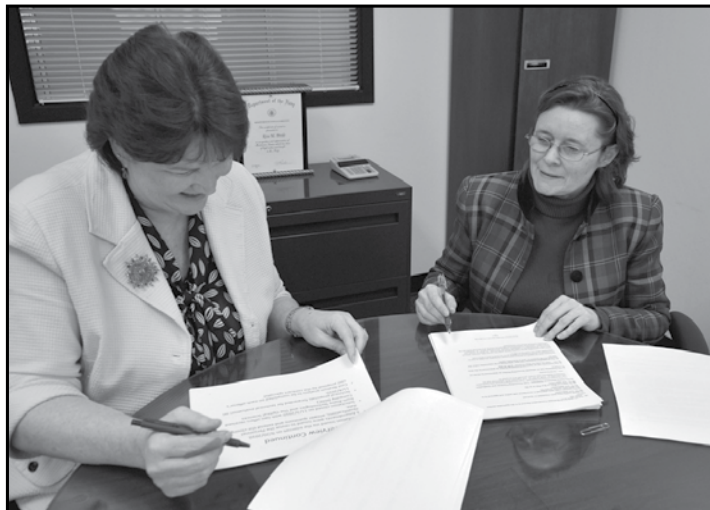

Specialist and Division Head discuss small business programs.

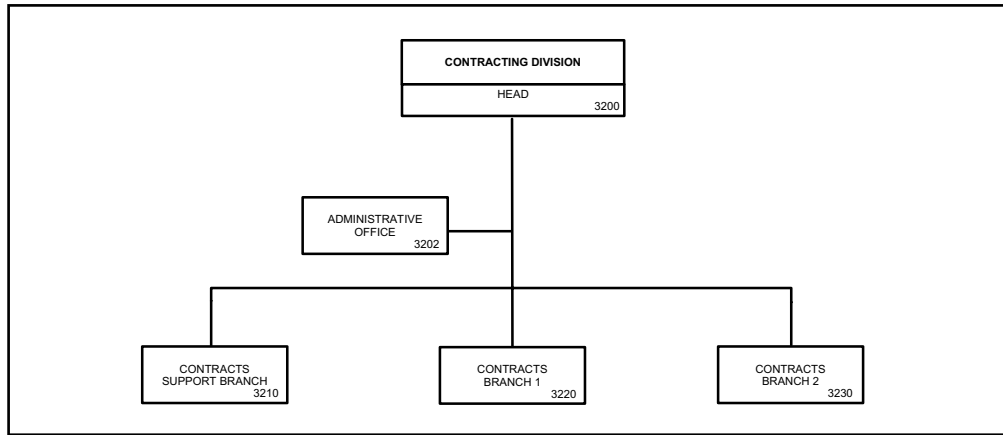

Basic Responsibilities

The Contracting Division is responsible for the acquisition of major research and development materials, services, and facilities where the value is in excess of \$100,000. It also maintains liaison with the ONR Procurement Directorate on procurement matters involving NRL. Specific functions include: providing consultant and advisory services to NRL division personnel on acquisition strategy, contractual adequacy of specifications, and potential sources; reviewing procurement requests for accuracy and completeness; initiating and processing solicitations for procurement; awarding contracts; performing contract administration and post-award monitoring of contract terms and conditions, delivery, contract changes, patents, etc., and taking corrective actions as required; providing acquisition-related training to division personnel; and interpreting and implementing acquisition-related Federal, Department of Defense, and Navy regulations.

Personnel: 30 full-time civilian

Key Personnel

Title	Code
Head, Contracting Division	3200
Administrative Officer	3202
Contracts Support Branch	3210
Head, Contracts Branch 1	3220
Head, Contracts Branch 2	3230
Head, Contracts Section, SSC	3235

Point of contact: Code 3202, (202) 767-3749

Financial Management Division

Code 3300 Staff Activity Areas

- Budget
- Reports and Statistics
- Accounting
- Travel Services
- Payroll Liaison



The Budget Branch prepares various financial analyses, reports, and studies in response to external data calls and/or management requests.



The Financial Systems, Reports, and Accounting Branch ensures that NRL's financial system satisfies user requirements and is in compliance with applicable rules and regulations, maintains official accounting records, and coordinates efforts with DFAS to complete payment transactions related to NRL business.

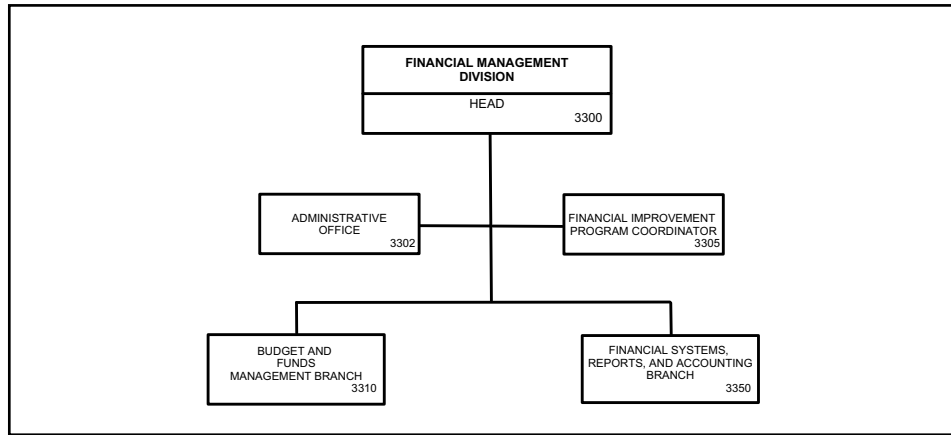

Basic Responsibilities

The Financial Management Division (FMD) develops, coordinates, and maintains an integrated system of financial management that provides the Comptroller, Commanding Officer, Director of Research, and other officials of NRL the information and support needed to fulfill the financial and resource management aspects of their responsibilities. FMD translates the NRL program requirements into the financial plan, formulates the NRL budget, monitors and evaluates performance with the budget plan, and provides recommendations and advice to NRL management for corrective actions or strategic program adjustments. FMD maintains the accounting records of NRL's financial and related resources transactions and prepares reports, financial statements, and other documents in support of NRL management needs and/or to comply with external reporting requirements. FMD provides financial management guidance, policies, advice, and documented procedures to ensure that NRL operates in compliance with Navy and DoD regulations and with economy and efficiency. FMD coordinates efforts with the Defense Finance and Accounting Service (DFAS) to complete payment transactions related to NRL business (e.g., the payment of NRL personnel for payroll and travel expenses and the payment to NRL's contractors and vendors for goods and services purchased by NRL). FMD coordinates Financial Improvement Program efforts to ensure the NRL is ready for an independent financial audit. Additionally, FMD develops, operates, and maintains automated business and management information systems supporting the lab-wide administrative and business processes, including financial management, procurement and contracting, stores and inventory, asset management, human resources, facilities, and security.

Personnel: 68 full-time civilian

Key Personnel

Title	Code
Head, Financial Management Division	3300
Administrative Officer	3302
Financial Improvement and Audit Readiness Coordinator	3305
Head, Budget and Funds Management Branch	3310
Head, Funding Section	3311
Head, Internal Budget Section	3312
Head, Corporate Budget Section	3313
Head, Financial Systems, Reports, and Accounting Branch	3350
Head, Cost Accounting Section	3351
Cost and Analysis Unit	3351.1
Head, Vendor Pay Unit	3351.2
Head, Financial Services Section	3352
Head, Payroll Services Unit	3352.1
Head, Travel Services Unit	3352.2
Head, Accounting Systems and Reports Section	3353
Head, Asset Management and Accounting Section	3354

Point of contact: Code 3302, (202) 767-2950

Supply and Information Services Division

Code 3400 Staff Activity Areas

- Purchasing
- Technical Information Services
- Customer Support and Program Management
- Material Control
- Administrative Services
- Automated Inventory Management System
- Disposal and Storage



Woodworkers prepare boxes for shipping.



Mail clerks sort mail by directorate and file into bins by organizational codes. Mail is bundled and delivered once a day.



Customers and employee at the Supply store.



Disposal and Storage in Building 49.



The Publications staff discusses design ideas for a new publication.

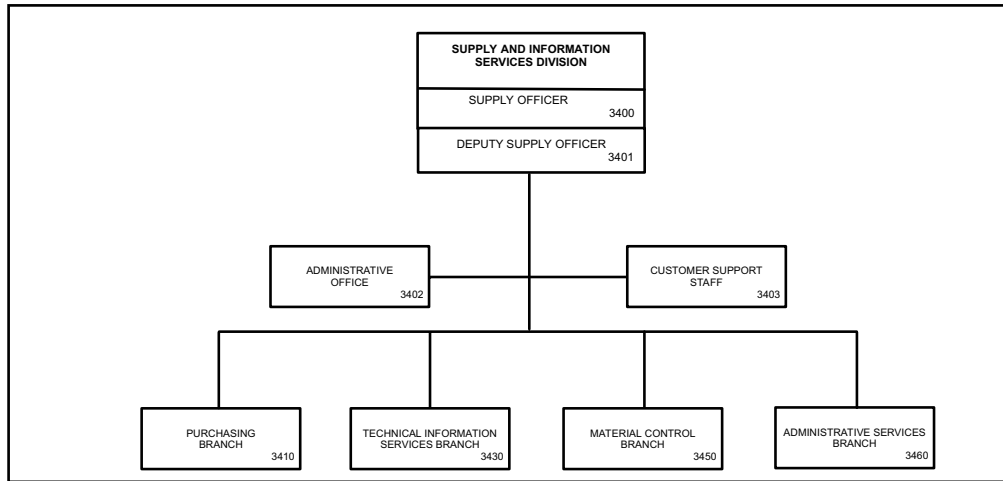

Basic Responsibilities

The Supply and Information Services Division provides the Laboratory and its field activities with contracting, supply management, logistics, administrative, and technical information services. Specific functions include: procuring required equipment, material, and services; receiving, inspecting, storing, and delivering material and equipment; packing, shipping, and traffic management; surveying and disposing of excess and unusable property; operating various supply issue stores and performing stock inventories; providing technical and counseling services for the research directorates in the development of specifications for a complete procurement package; and obtaining and providing guidance in the performance stages of contractual services. Services also include publications, visual information, exhibits, photography, editing, and mailroom services and correspondence management.

Personnel: 102 full-time civilian

Key Personnel

Title	Code
Supply Officer	3400
Deputy Supply Officer	3401
Administrative Officer	3402
Head, Customer Support Staff	3403
Head, Purchasing Branch	3410
Head, Technical Information Services Branch	3430
Head, Material Control Branch	3450
Head, Administrative Services Branch	3460

Point of contact: Code 3402, (202) 404-1701

Research and Development Services Division

Code 3500 Staff Activity Areas

- Technical/Support Services
- Production Control
- Shop Services
- Chesapeake Bay Section
- Customer Liaison
- Safety
- Occupational, Safety and Health/Industrial Hygiene
- Explosives Safety
- Health Physics
- Environmental
- Administrative Office
- Telephones
- Facilities Planning and Operations



Interstitial hardening furnace



Safety Office – processing procurement requests for safety equipment

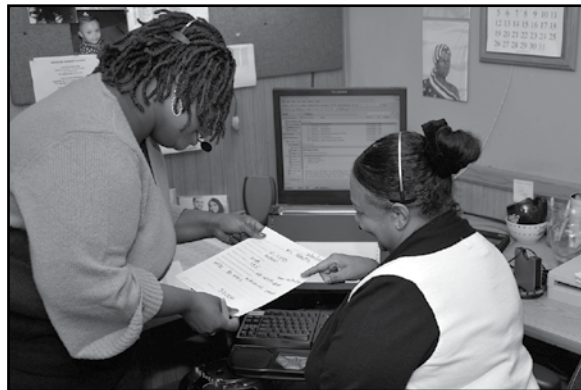

Service Desk – processing service calls

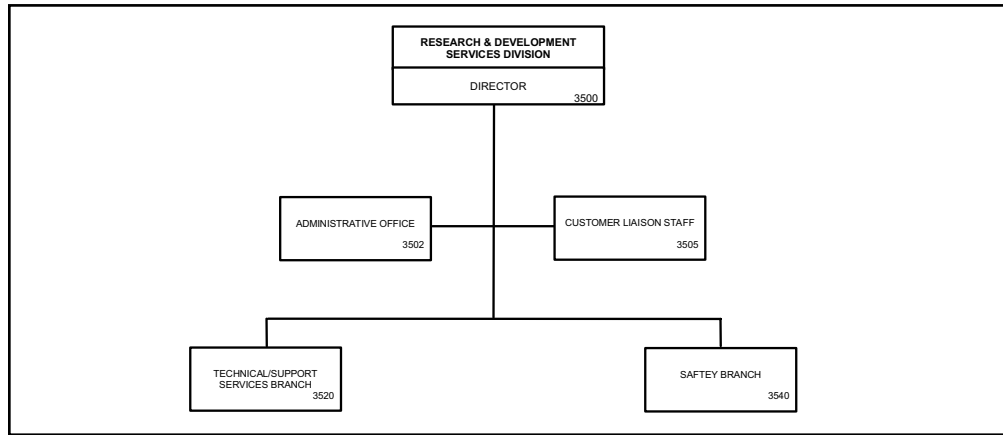

Basic Responsibilities

The Research and Development Services Division is responsible for the physical plant of the Naval Research Laboratory and subordinate field sites. The responsibilities include military construction, engineering, and coordination of construction; facility support services, planning, maintenance/repair/operation of all infrastructure systems; transportation; and occupational safety, health and industrial hygiene, and environmental safety.

The Division provides engineering and technical assistance to research divisions in the installation and operation of critical equipment in support of the research mission.

Personnel: 141 full-time civilian

Key Personnel

Title	Code
Director, Research and Development Services Division	3500
Administrative Officer	3502
Customer Liaison	3505
Head, Technical/Support Services Branch	3520
Head, Engineering Section	3521
Head, Chesapeake Bay Section	3522
Head, Shop Services Section	3523
Head, Production Control Section	3524
Head, Facilities, Planning and Operations Section	3525
Head, Safety Branch	3540
Occupational Safety and Health/Industrial Hygiene Section	3541
Explosives Safety	3542
Health Physics Section	3544
Environmental Section	3546
Environmental Response Unit	3546.1

Point of contact: Code 3502, (202) 404-4312

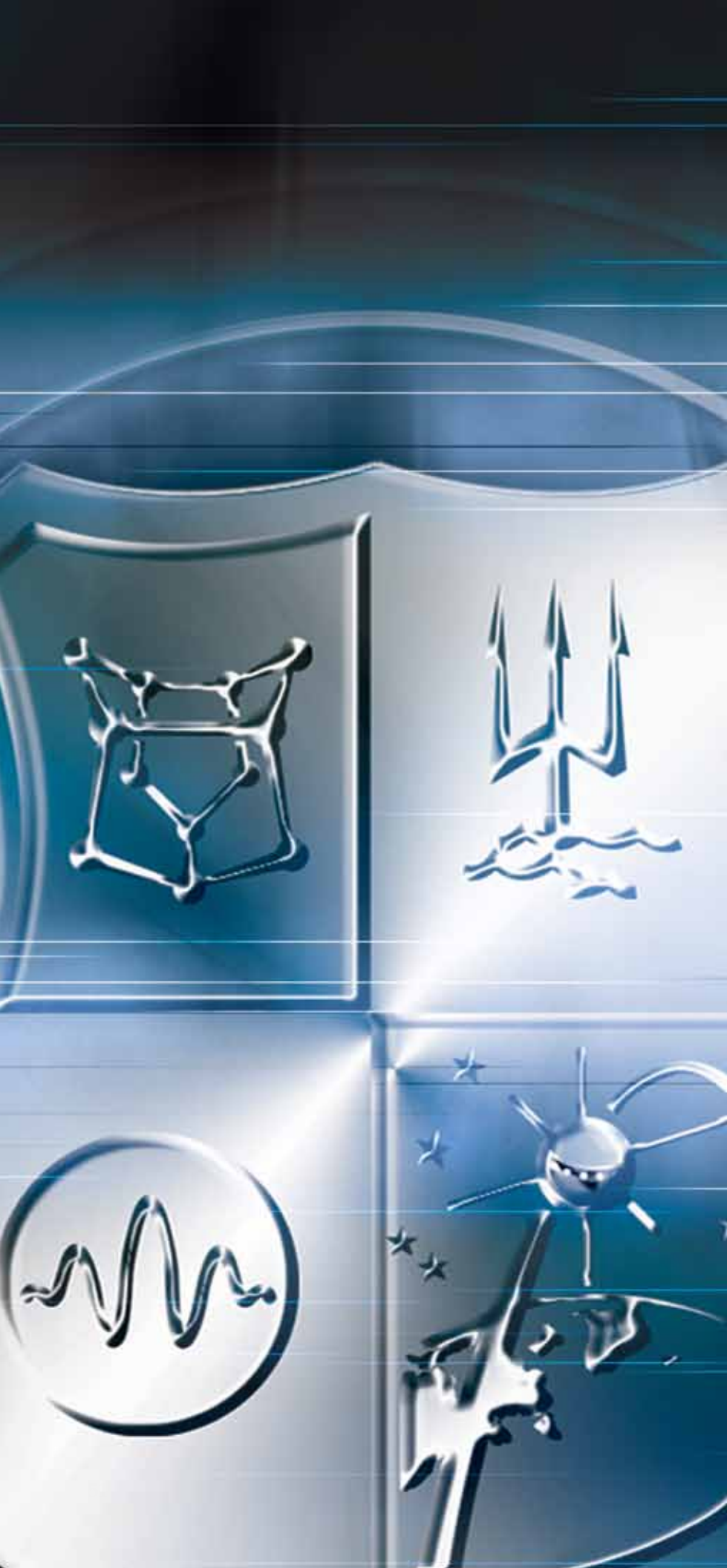

**Systems
Directorate**



SYSTEMS DIRECTORATE

Code 5000

The Systems Directorate applies the tools of basic research, concept exploration, and engineering development to expand operational capabilities and to provide materiel support to Fleet and Marine Corps missions. Emphasis is on technology, devices, systems, and know-how to acquire and move warfighting information and to deny these capabilities to the enemy. Current activities include:

- New and improved radar systems to detect and identify ever smaller targets in the cluttered littoral environment;
- Optical sensors and related materials to extract elusive objects in complex scenes when both processing time and communications bandwidth are limited;
- Unique optics-based sensors for detection of biochemical warfare agents and pollutants, for monitoring structures, and for alternative sensors;
- Advanced electronic support measures techniques for signal detection and identification;
- Electronic warfare systems, techniques, and devices including quick-reaction capabilities;
- Innovative concepts and designs for reduced observables;
- Techniques and devices to disable and/or confuse enemy sensors and information systems;

- Small “intelligent”/autonomous land, sea, or air vehicles to carry sensors, communications relays, or jammers; and

- High performance/high assurance computers with right-the-first-time software and known security characteristics despite commercial off-the-shelf components and connections to public communications media.

Many of these efforts extend from investigations at the frontiers of science to the support of deployed systems in the field, which themselves provide direct feedback and inspiration for applied research and product improvement and/or for quests for new knowledge to expand the available alternatives.

In addition to its wide-ranging multidisciplinary research program, the Directorate provides support to the corporate laboratory in shared resources for high performance computing and networking, technical information collection and distribution, and in coordination of Laboratory-wide efforts in signature technology, counter-signature technology, Theater Missile Defense, and the Naval Science Assistance Program.

Associate Director of Research for Systems



Dr. G.M. Borsuk is the Associate Director of Research for Systems at the Naval Research Laboratory (NRL) in Washington, DC. In this position he provides executive direction and leadership to four major NRL research divisions that conduct a broad multidisciplinary program of scientific research and advanced technological development in the areas of optics, electromagnetics, information technology, and radar. He is responsible for the conduct and effectiveness of research programs conducted within these divisions and for the overall administration of activities throughout the Systems Directorate. He is also the Focus Area Coordinator

for all NRL base programs in electronics science and technology. Prior to this appointment, Dr. Borsuk served for 23 years as the Superintendent of the Electronics Science and Technology Division at NRL where he was responsible for the in-house execution of a multidisciplinary program of basic and applied research in electronic materials and structures, solid state devices, vacuum electronics, and circuits. Dr. Borsuk also serves as the Technical Chair of the DDR&E's Electronic Warfare Technology Task Force (EWTTF). He was the Navy Deputy Program Manager and Technical Director for the now completed DARPA/Tri-Service MIMIC and MAFET Programs. He was the Department of Defense (DoD) technical representative for Electronics to the Wassenaar Arrangement dealing with export control. He has also served as the DoD representative to the President's National Science and Technology Council's Electronic Materials Working Group.

Dr. Borsuk joined the ITT Electro-Physics Laboratory in Columbia, Maryland, as a staff physicist in 1973, where he worked on the application of charge-coupled devices (CCDs) for imaging and signal processing. In 1976 he joined the Westinghouse Advanced Technology Laboratory in Baltimore, Maryland, developing advanced silicon VLSI integrated circuits and performing device physics research. He performed original work in the design and fabrication of CCDs for signal processing and photodetectors for use with acousto-optic signal processors. He headed the Westinghouse VHSIC effort in advanced sub-micron VLSI device technology. Dr. Borsuk was department manager of Solid State Sciences at the Advanced Technology Laboratory when he left Westinghouse in 1983 to join the Naval Research Laboratory as the Superintendent of the Electronics Science and Technology Division.

Dr. Borsuk received a Ph.D. in physics from Georgetown University in Washington, DC, in 1973. He is a Fellow of the IEEE, a member of the American Physical Society, a member of the AVS, and is a member of Sigma Xi. He has 37 technical publications, four patents, and eleven invention disclosures. He is the recipient of four Presidential Rank Senior Executive Awards, the Distinguished, the most recent awarded in 2010. He is also the recipient of the IEEE Frederik Philips Award, the IEEE Harry Diamond Memorial Award, the IEEE Millennium Medal, and an IR-100 Award for his work on high-speed CCDs. Dr. Borsuk also served on the editorial board of the IEEE Proceedings.

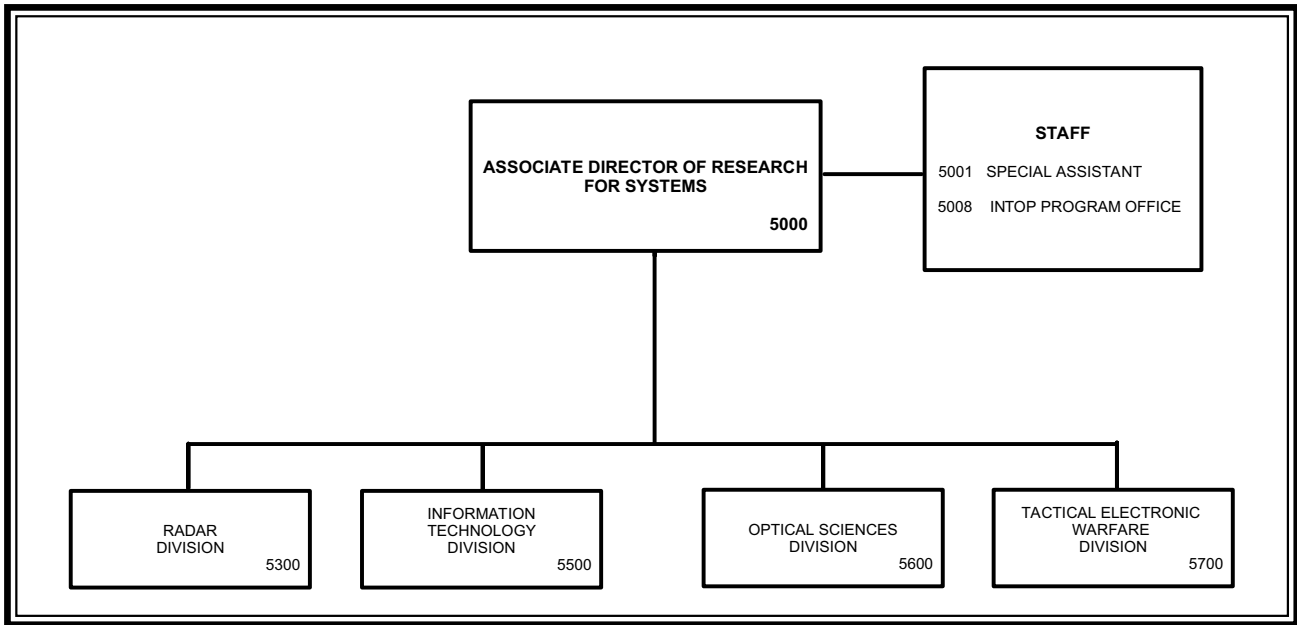

Key Personnel

Title	Code
Associate Director of Research for Systems	5000
Special Assistant	5001
Special Consultant	5007
Head, InTop Program Office	5008
Superintendent, Radar Division	5300
Superintendent, Information Technology Division	5500
Superintendent, Optical Sciences Division	5600
Superintendent, Tactical Electronic Warfare Division	5700

Point of contact: Code 5000A, (202) 767-3324

Radar Division

Code 5300 Staff Activity Areas

AEGIS coordination
Marine Corps/Air Force coordination

Maritime Domain Awareness
Multifunction RF systems

High-power millimeter-wave radar

Research Activity Areas

Radar Analysis

- Target signature prediction
- Electromagnetics and antennas
- Airborne early-warning radar (AEW)
- Inverse synthetic aperture radar (ISAR)
- Sea clutter modeling
- Periscope detection
- Wideband array simulation and fabrication

Advanced Radar Systems

- High-frequency over-the-horizon radar
- Signal analysis
- Real-time signal processing and equipment
- Computer-aided engineering (CAE)
- Array architecture optimization
- FPGA-based digital processing
- Future identification technology

Surveillance Technology

- Shipboard surveillance radar
- Ship self-defense
- Electronic counter-countermeasures and electronic protection (EP)
- Target signature recognition
- Digital T/R modules
- Asymmetric and expeditionary warfare spectrum management
- Ultrawideband technology
- Dynamic waveform diversity
- Multistatic radar network
- Information extraction
- Ballistic missile defense
- Mine detection

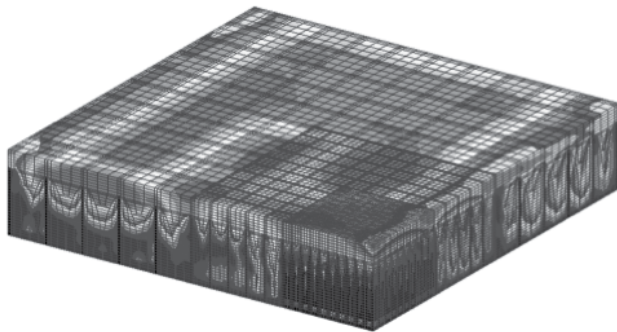

Wavelength scaled array: an ultrawideband array concept providing constant beamwidth across 8:1 bandwidth; designed by NRL-developed Domain Decomposition Algorithm.



The Advanced Multifunction RF Concept (AMRFC) test bed is a proof-of-principle demonstration system capable of simultaneously transmitting and receiving multiple beams from common transmit and receive array antennas for radar, electronic warfare, and communications.

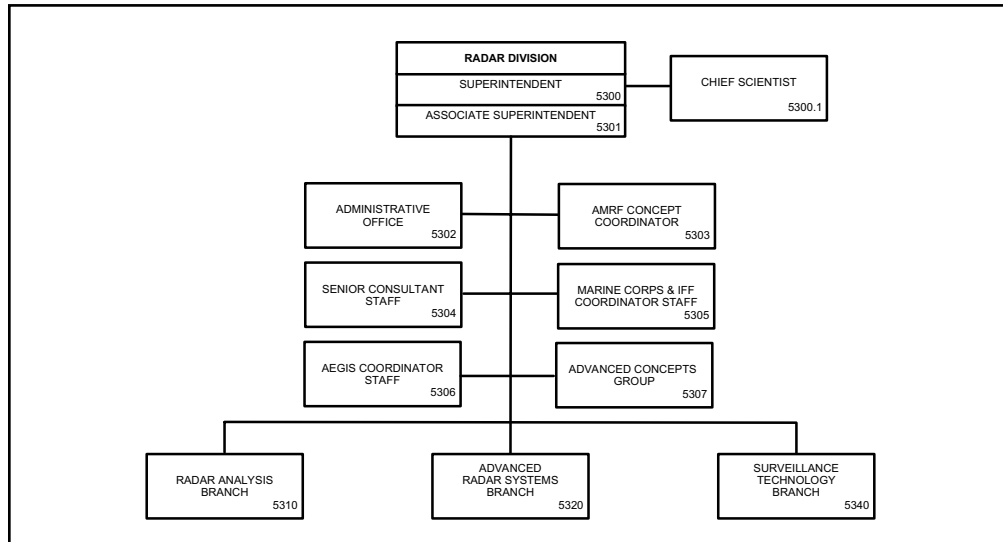

Basic Responsibilities

The Radar Division conducts research on basic physical phenomena of importance to radar and related sensors, investigates new engineering techniques applicable to radar, demonstrates the feasibility of new radar concepts and systems, performs related systems analyses and evaluation of radar, and provides special consultative services. The emphasis is on new and advanced concepts and technology in radar and related sensors that are applicable to enhancing the Navy's ability to fulfill its mission.

Personnel: 94 full-time civilian

Key Personnel

Title	Code
Superintendent, Radar Division	5300
Associate Superintendent	5301
Administrative Officer	5302
Senior Consultant Staff	5304
Marine Corps and IFF Coordinator	5305
AEGIS Coordinator	5306
Head, Advanced Concepts Group	5307
Head, Radar Analysis Branch	5310
Head, Advanced Radar Systems Branch	5320
Head, Surveillance Technology Branch	5340

Point of contact: Code 5300, (202) 404-2700

Information Technology Division

Code 5500 Research Activity Areas

Freespace Photonics Communications Office

- Extended spectrum communications
- Atmospheric channel effects on photonic transfer
- Studies in marine miraging
- Analog modulation techniques on freespace optical carriers
- Modulating retroreflector based communications
- Signature studies for ISR
- Adaptive optics for freespace optical communications

Adversarial Modeling and Exploitation Office

- Hostile intent and deception detection
- Behavior detection research
- Geospatial modeling and simulation
- Dynamic semantic networks
- Behavioral modeling, analysis and metrics
- Spatially integrated social science
- Integrated intelligence, surveillance, and reconnaissance
- Automated video analysis and retrieval

Navy Center for Applied Research in Artificial Intelligence

- Intelligent decision aids
- Natural language and multimodal interfaces
- Intelligent software agents
- Machine learning and adaptive systems
- Robotics software and computer vision
- Neural networks
- Novel devices/techniques for HCI
- Spatial audio
- Immersive simulation
- Autonomous and intelligent systems
- Case-based reasoning and problem-solving methods
- Machine translation technology evaluation
- Cognitive architectures
- Human-robot interaction

Transmission Technology

- Communication system architecture
- Communication antenna/propagation technology
- Communications intercept systems
- Virtual engineering
- Secure voice technology
- Satellite and tactical networking
- Satellite communications research
- Satellite architecture analysis
- RF systems analysis

Center for High Assurance Computer Systems

- Secure service oriented architectures (SOA) and Secure Enterprise Architectures (SEA)
- Formal specification/verification of system security
- COMSEC application technology
- Technology and solutions to secure networks and databases
- Software engineering for secure systems
- Key management and distribution solutions
- Information systems security (INFOSEC) engineering
- Formal methods for requirements specification and verification
- Security product development
- Secure wireless network and wireless sensor technology
- Network security protocol modeling, simulation, and verification
- Cross-domain solution technology development
- Computer Network Defense (CND) technology

- Hardware/software co-design
- Malicious code analysis
- Information hiding (watermarking, covert channel analysis, etc.)
- Anonymizing systems
- Quantum information science
- Logical foundations of security

Networks and Communication Systems

- Communication system engineering
- Mobile, wireless networking technology
- Bandwidth management (quality of service)
- Joint service tactical networking
- Integration of communication and C2 applications
- Automated testing of highly mobile tactical networks
- Reliable multicast protocols and applications
- Communication network simulation
- Networking protocols for directional antennas
- Policy-based network management
- Tactical voice-over IP
- Sensor networks
- Advanced tactical data links
- Cognitive radio technology

Information Management and Decision Architectures

- Virtual reality/mobile augmented reality
- Visual analytics
- Scientific visualization
- Computer graphics
- Human-computer interaction
- Service oriented architecture
- Service orchestration
- Data and information management
- Human-centered design
- Parallel and distributed computation
- Distributed modeling and simulation
- Natural environments for distributed simulation
- Intelligent decision support
- Information sharing
- Semantic web technology
- Data mining
- Software agents for data fusion

Center for Computational Science

- Transparent optical network research and design
- Parallel computing
- Scalable high performance computing and networking for Navy and DoD
- Large data in distributed computing
- Scientific visualization
- High-performance file systems
- High-definition video technology
- NRL labwide computer network and related services
- Labwide support for web, email, and other information services
- ATDnet and leading-edge WAN research networks

Ruth H. Hooker Research Library

- Desktop/workbench access to relevant scientific resources
- NRL scientific digital archive (TORPEDO)
- Authoritative database of NRL-produced publications (NRL Online Bibliography)
- Comprehensive literature/citation/classified searches
- Extensive collection of print and digital books, journals, and technical reports

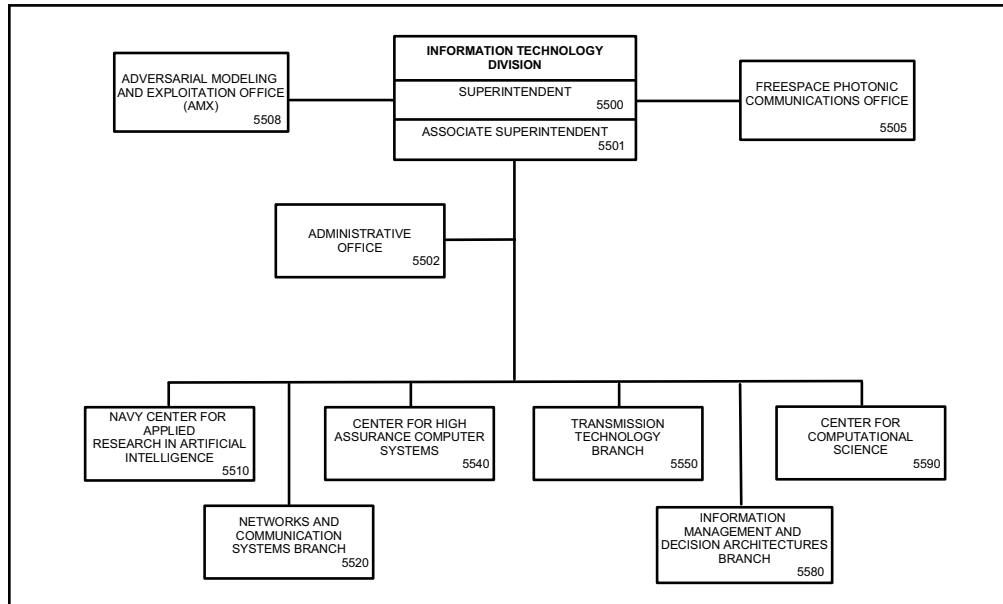

Basic Responsibilities

The Information Technology Division conducts basic research, exploratory development, and advanced technology demonstrations in the collection, transmission, processing, presentation, and distribution of information to provide information superiority and distributed networked force capabilities that improve Naval operations across all mission areas. The Division provides immediate solutions to current operational needs as required while developing those technologies necessary to implement the Navy after next.

Personnel: 204 full-time civilian

Key Personnel

Title	Code
Superintendent/NRL Chief Information Officer	5500
Associate Superintendent	5501
Administrative Officer	5502
Head, Freespace Photonic Communications Office	5505
Head, Adversarial Modeling and Exploitation Office	5508
Director, Navy Center for Applied Research in Artificial Intelligence	5510
Head, Networks and Communication Systems Branch	5520
Director, Center for High Assurance Computer Systems	5540
Head, Transmission Technology Branch	5550
Head, Information Management and Decision Architectures Branch	5580
Director, Center for Computational Science	5590
Chief Librarian, Ruth H. Hooker Research Library	5596

Point of contact: Code 5501, (202) 767-2954

Optical Sciences Division

Code 5600 Staff Activity Areas

Program analysis and development
Special systems analysis
Technical study groups

Technical contract monitoring
Theoretical studies

Research Activity Areas

Optical Materials and Devices

Advanced infrared optical materials
IR fiber-optic materials and devices
IR fiber chemical and environmental sensors
IR transmitting windows and domes
Transparent ceramic armor materials
Planar waveguide devices
IR nonlinear materials and devices
Ceramic laser gain materials
Advanced solar cell materials
Fiber lasers/sources and amplifiers
Radiation effects

Optical Physics

Laser materials diagnostics
Nonlinear frequency conversion
Optical instrumentation and probes
Optical interactions in semiconductor superlattices and organic solids
Laser-induced reactions
Organic light-emitting devices
Nanoscale electro-optical research
Aerosol optics

Applied Optics

UV, optical, and IR countermeasures
Ultraviolet component development
Missile warning sensor technology
UV, visible, and IR imager development
Multispectral/hyperspectral sensors
Multispectral/hyperspectral/detection algorithms
Framing reconnaissance sensors
Novel optical components
Sensor control and exploitation system development
IR low observables
EO/IR systems analysis
Atmospheric IR measurements
Airborne IR search and track technology

Photonics Technology

Fiber and solid-state laser/sources
High-speed (<100 fs) optical probing
High-power fiber amplifiers
High-speed fiber-optic communications
Antenna remoting
Free space communication
Photonic control of phased arrays
Micro-electro-optical-mechanical systems
Optical clocks
Microwave photonics

Optical Techniques

Fiber-optic materials and fabrication
Fiber Bragg grating sensors/systems
Fiber-optic sensors/systems (acoustic, magnetic, gyroscopes)
Integrated optics

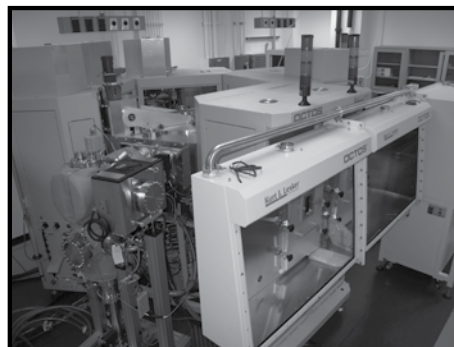

The Advanced Optical Materials Fabrication Laboratory, a state-of-the-art high vacuum cluster system, consists of a series of interconnected chambers allowing vacuum deposition of complex, multilayer films to be deposited and patterned without breaking vacuum during processing.



The Optical Fiber Preform Fabrication Facility includes computer control of the glass composition and standard fiber-optic dopants as well as rare earths, aluminum, and other components for specialty fibers.

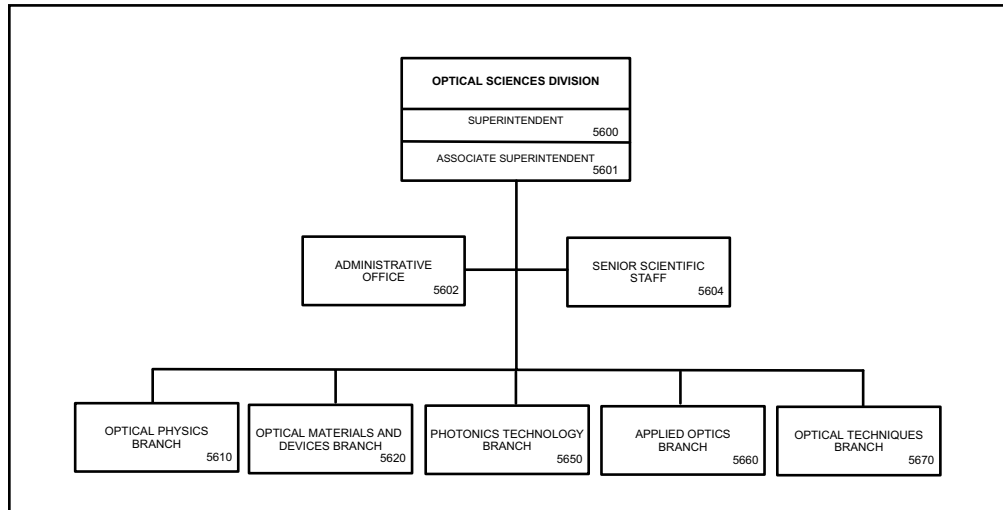

Basic Responsibilities

The Optical Sciences Division carries out a variety of research, development, and application-oriented activities in the generation, propagation, detection, and use of radiation in the wavelength region between near-ultraviolet and far-infrared wavelengths. The research, both theoretical and experimental, is concerned with discovering and understanding the basic physical principles and mechanisms involved in optical devices, materials, and phenomena. The development effort is aimed at extending this understanding in the direction of device engineering and advanced operational techniques. The applications activities include systems analysis, prototype system development, and exploitation of R&D results for the solution of optically related military problems. In addition to its internal program activities, the Division serves the Laboratory specifically and the Navy generally as a consulting body of experts in optical sciences. The work in the Division includes studies in quantum optics, laser physics, optical waveguide technologies, laser-matter interactions, atmospheric propagation, holography, optical data processing, fiber-optic sensor systems, optical systems, optical materials, radiation damage studies, IR surveillance and missile seeker technologies, IR signature measurements, and optical diagnostic techniques. A portion of the effort is devoted to developing, analyzing, and using special optical materials.

Personnel: 137 full-time civilian

Key Personnel

Title	Code
Superintendent, Optical Sciences Division	5600
Associate Superintendent	5601
Administrative Officer	5602
Head, Senior Scientific Staff	5604
Head, Optical Physics Branch	5610
Head, Optical Materials and Devices Branch	5620
Head, Photonics Technology Branch	5650
Head, Applied Optics Branch	5660
Senior Scientific Staff	5660.1
Head, Optical Techniques Branch	5670

Point of contact: Code 5602, (202) 767-6986

Tactical Electronic Warfare Division

Code 5700 Staff Activity Areas

EW Strategic Planning
Signature Technology Office

Effectiveness of Naval EW Systems (ENEWS)

Research Activity Areas

Offboard Countermeasures

Expendable technology and devices
Unmanned air vehicles
Offboard payloads
Decoys

Airborne Electronic Warfare Systems

Air systems development
Penetration aids
Power source development
Jamming and deception
Millimeter-wave technology
Communications CM

Ships Electronic Warfare Systems

Ships systems development
Jamming technology and deception
EW antennas
High power microwaves (HPM) research

Electronic Warfare Support Measures

Intercept systems and direction finders
RF signal simulators
Systems integration
Command and control interfaces
Signal processing

Advanced Techniques

Analysis and modeling simulation
Experimental systems
EW concepts
Infrared technology

Integrated EW Simulation

Hardware-in-the-loop simulation
Data management technology
Flyable ASM seeker simulators
Foreign materiel exploitation (FME)

EW Modeling and Simulation

High-fidelity threat models and simulations
Advanced system visualization
EW tactical decision aids
RF environmental and propagation modeling

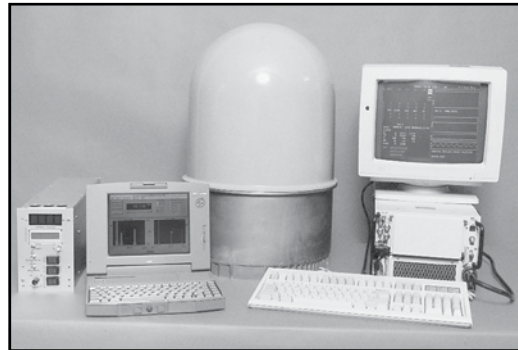
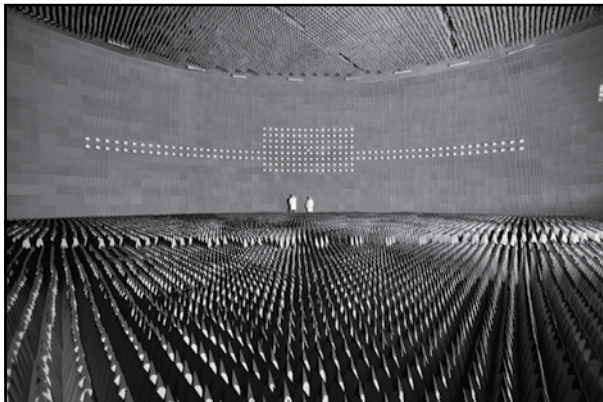

Using the latest composite, MMIC, and processing technologies, the Tactical Electronic Warfare Division has developed a small, lightweight, and inexpensive ESM receiving system for use on frigates, Coast Guard vessels, and various patrol aircraft.

The Central Target Simulator (CTS) Programmable Array is part of a large hardware-in-the-loop simulation facility whose purpose is to test and evaluate electronic warfare systems and techniques used to counter radar-guided missile threats to Navy forces.

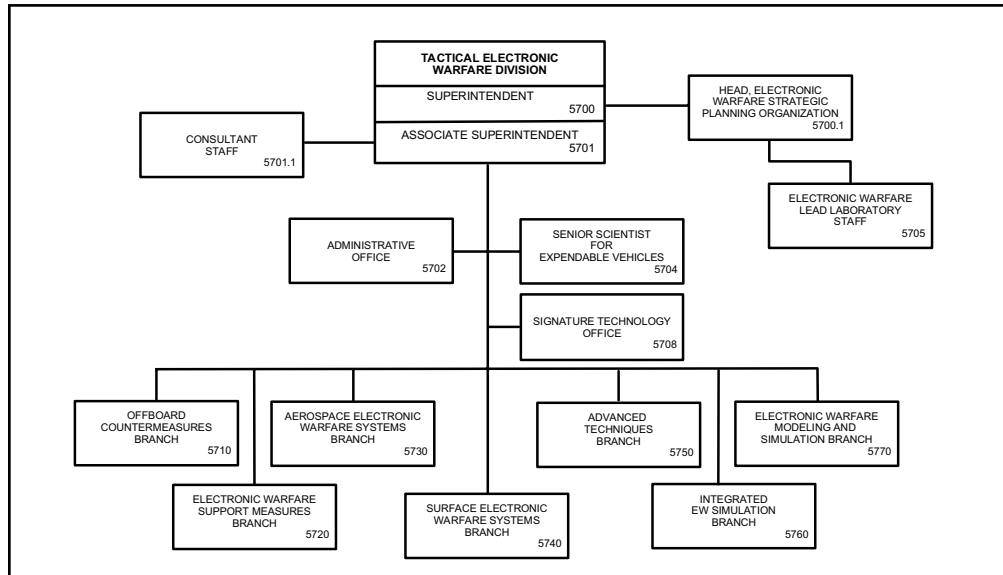

Basic Responsibilities

The Tactical Electronic Warfare Division (TEWD) is responsible for research and development in support of the Navy's tactical electronic warfare requirements and missions. These include electronic warfare support measures, electronic countermeasures, and supporting counter-countermeasures, as well as studies, analyses, and simulations for determining and improving the effectiveness of these systems.

Personnel: 237 full-time civilian

Key Personnel

Title	Code
Superintendent, Tactical Electronic Warfare Division	5700
Head, Electronic Warfare Strategic Planning Organization	5700.1
Associate Superintendent	5701
Administrative Officer	5702
Senior Scientist for Expendable Vehicles	5704
Head, Electronic Warfare Lead Laboratory Staff	5705
Head, Signature Technology Office	5708
Head, Offboard Countermeasures Branch	5710
Head, Electronic Warfare Support Measures Branch	5720
Head, Aerospace Electronic Warfare Systems Branch	5730
Head, Surface Electronic Warfare Systems Branch	5740
Head, Advanced Techniques Branch	5750
Head, Integrated Electronic Warfare Simulation Branch	5760
Head, Electronic Warfare Modeling and Simulation Branch	5770

Point of contact: Code 5701, (202) 767-5974

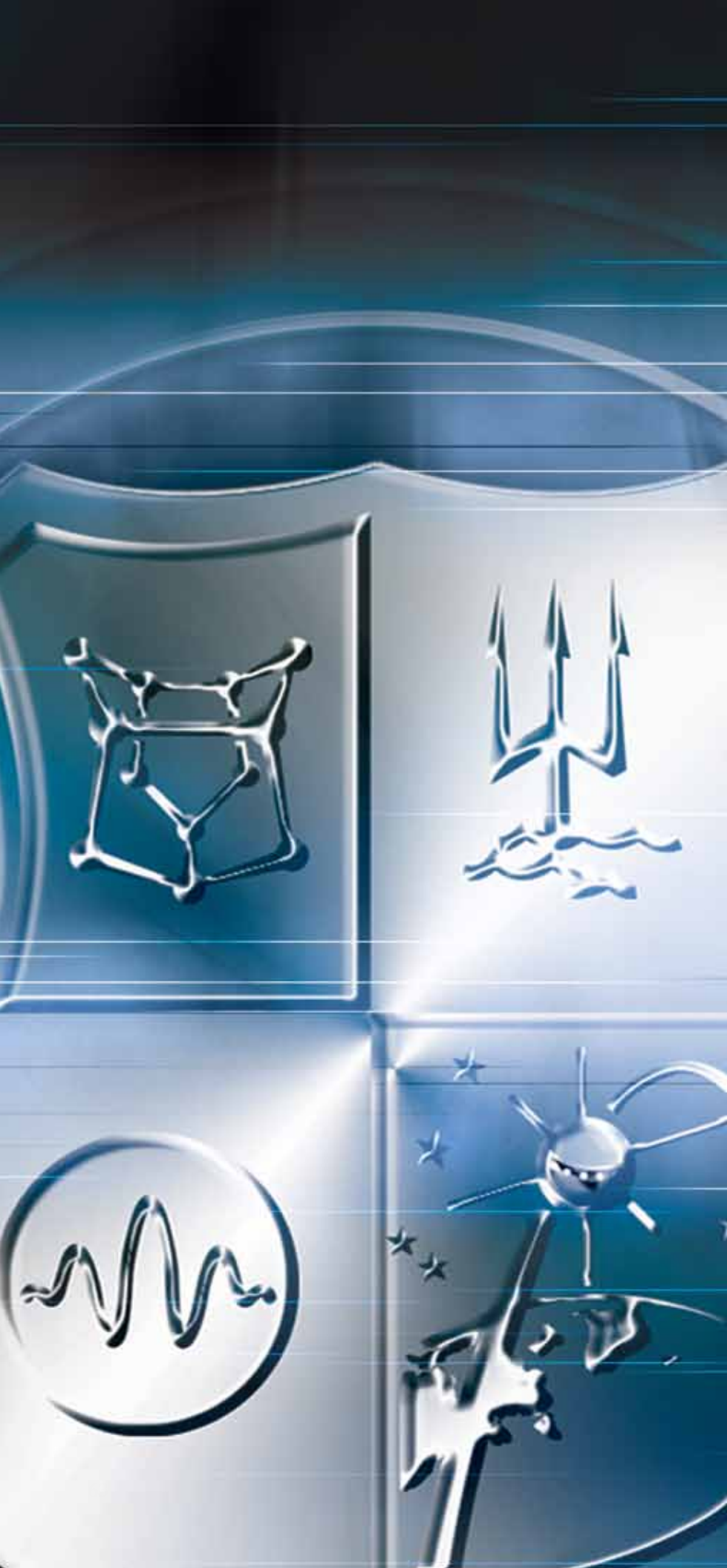

**Materials
Science and
Component
Technology
Directorate**

MATERIALS SCIENCE AND COMPONENT TECHNOLOGY DIRECTORATE

Code 6000

The Materials Science and Component Technology Directorate carries out a multidisciplinary research program whose objectives are the discovery, invention, and exploitation of new improved materials, the generation of new concepts associated with materials behavior, and the development of advanced components based on these new and improved materials and concepts. Theoretical and experimental research is carried out to determine the scientific origins of materials behavior and to develop procedures for modifying these materials to meet important naval needs for advanced platforms, electronics, sensors, and photonics.

The program includes investigations of a broad spectrum of materials including insulators, semiconductors, superconductors, metals and alloys, optical materials, polymers, plastics, artificially structured bio/molecular materials and composites, and energetic materials, which are used in important naval devices, components, and systems. New techniques are developed for producing, processing, and fabricating these

materials for crucial naval applications.

The synthesis, processing, properties, and limits of performance of these new and improved materials in natural or radiation environments, and under deleterious conditions such as those associated with the marine environment, neutron or directed energy beam irradiation, or extreme temperatures and pressures, are established. For new materials design, emphasis is placed on protection of the environment.

Additionally, major thrusts are directed in advanced sensing, detection, reactive flow physics, computational physics, and plasma sciences. Areas of particular emphasis include nanoscience and technology, fluid mechanics and hydrodynamics, nuclear weapon effects simulations, high energy density materials including fuels, propellants, explosives, and storage devices, interactions of various types of radiation with matter, survivability of materials and components, and directed energy devices.

Associate Director of Research for Materials Science and Component Technology



Dr. B.B. Rath was born in Banki, India. He received a B.S. degree in physics and mathematics from Utkal University, an M.S. in metallurgical engineering from Michigan Technological University, and a Ph.D. from the Illinois Institute of Technology.

Dr. Rath was Assistant Professor of Metallurgy and Materials Science at Washington State University from 1961 to 1965. From 1965 to 1972, he was with the staff of the Edgar C. Bain Laboratory for fundamental research of the U.S. Steel Corporation. From 1972 to 1976, he headed the Metal Physics Research Group of the McDonnell Douglas Research Laboratories in St. Louis, Missouri, until he came to NRL as Head of the Physical Metallurgy Branch. During this period, he was adjunct professor at Carnegie-Mellon University, the University of Maryland, and the Colorado School of Mines. Dr. Rath served as Superintendent of the Materials Science and Technology Division from 1982 to 1986, when he was appointed to his present position.

Dr. Rath is recognized in the fields of solid-state transformations, grain boundary migrations, and structure-property relationships in metallic systems. He has published over 140 papers in these fields and edited several books and conference proceedings.

Dr. Rath serves on several planning, review, and advisory boards for both the Navy and the Department of Defense, as well as for the

National Materials Advisory Board of the National Academy of Sciences, National Science Foundation, University of Virginia, Colorado School of Mines, and the University of Florida. He is currently the Navy representative to the DOE Deputy Assistant Secretary's advisory and planning committee on methane hydrates, and the Navy representative to the Indo-U.S. Joint Commission on Science and Technology. He previously served as the Navy representative to the panel of The Technical Cooperation Program (TTCP) countries.

Dr. Rath is a member of the National Academy of Engineering. He is a fellow of the Minerals, Metals and Materials Society (TMS), American Society for Materials-International (ASM), Washington Academy of Sciences, Materials Research Society of India, the Institute of Materials of the United Kingdom, and the American Association for the Advancement of Science (AAAS). In 2007, Dr. Rath received an honorary doctorate in engineering from the Michigan Technological University and was elected to deliver the commencement address to the 2007 graduating class. In 2008, he received the Illinois Institute of Technology Mechanical Materials & Aerospace Engineering Department 2008 Alumni Recognition Award. In 2010, he received an honorary doctorate from Ravenshaw University.

Dr. Rath has received a number of honors and awards, most recently the Michigan Technological University Distinguished Alumni Award, the Padma Bhushan Award of Honors and Excellence bestowed by the President of India, and the Acta Materialia J. Herbert Hollomon Award. His other awards include the DoD Distinguished Civilian Service Award which is presented by the Secretary of Defense for distinguished accomplishments and sustained superior service, the 2005 Fred Saalfeld Award for Outstanding Lifetime Achievement in Science, the Presidential Rank Award for Distinguished Executive (2005), the NRL Lifetime Achievement Award (2004), National Materials Advancement Award from the Federation of Materials Societies (2001), the Presidential Rank of Meritorious Executive Award (1999 and 2004), the S. Chandrasekhar Award and Medal, and the Award of Merit for Group Achievement from the Chief of Naval Research. He received the 1991 George Kimball Burgess Memorial Award, the Charles S. Barrett Medal, and the prestigious TMS Leadership Award for his contributions to materials research. The American Society for Materials-International and The Metals, Minerals, and Materials Society have jointly recognized him with the TMS/ASM Joint Distinguished Lectureship in Materials & Society Award and the 2001 ASM Distinguished Life Membership Award. He has served as the 2004–2005 President of the American Society for Materials. He also has served as a member of the Boards of Directors/Trustees of TMS, ASM-International, and the Federation of Materials Society (FMS), as a member of the editorial boards of three international materials research journals, and as chairman of several committees of TMS, ASM, FMS, and American Association of Engineering Societies.

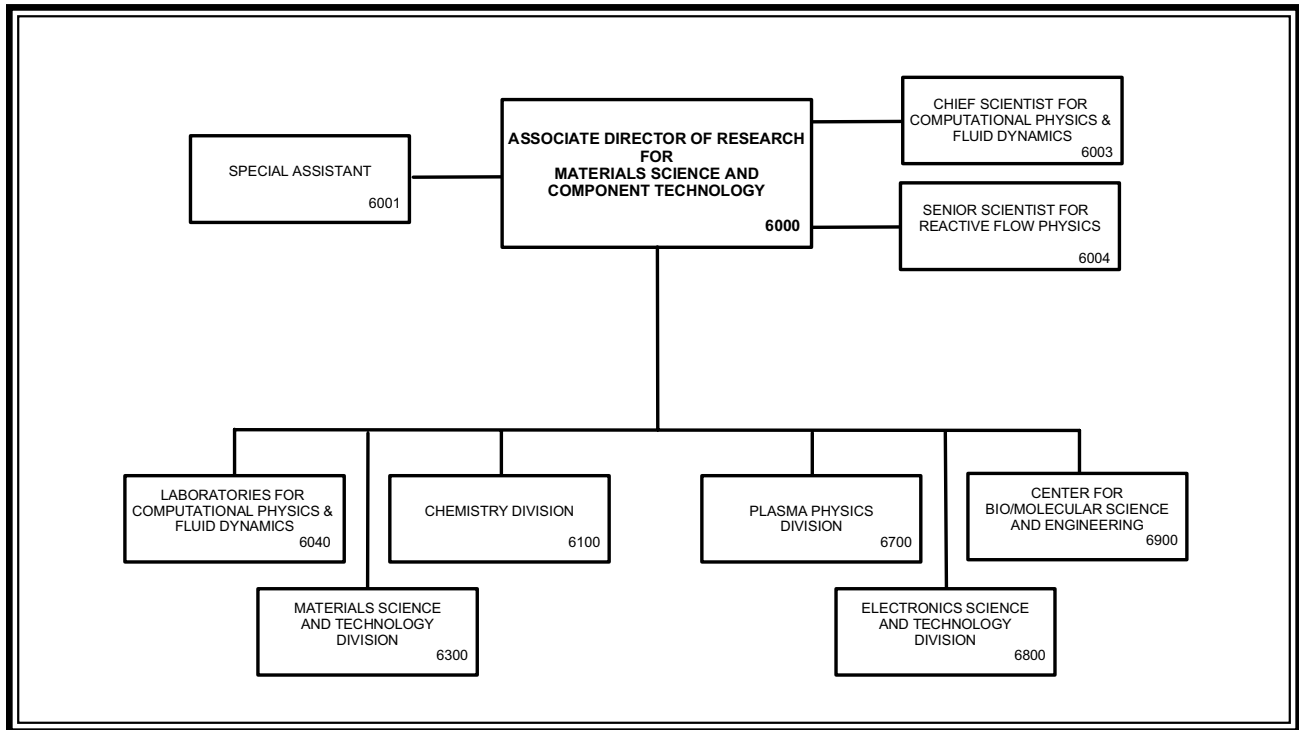

Key Personnel

Title	Code
Associate Director of Research for Materials Science and Component Technology	6000
Special Assistant	6001
Chief Scientist for Computational Physics and Fluid Dynamics	6003
Senior Scientist for Reactive Flow Physics	6004
Director, Laboratories for Computational Physics and Fluid Dynamics	6040
Superintendent, Chemistry Division	6100
Superintendent, Materials Science and Technology Division	6300
Superintendent, Plasma Physics Division	6700
Superintendent, Electronics Science and Technology Division	6800
Director, Center for Bio/Molecular Science and Engineering	6900

Point of contact: Code 6000, (202) 767-2538

Laboratories for Computational Physics and Fluid Dynamics

Code 6040 Research Activity Areas

Reactive Flows

- Fluid dynamics in combustion
- Turbulence in compressible flows
- Multiphase flows
- Turbulent jets and wakes
- Turbulence modeling
- Computational hydrodynamics
- Propulsion systems analysis
- Contaminant transport modelling
- Fire and explosion mitigation

Computational Physics Developments

- Laser-plasma interactions
- Inertial confinement fusion
- Solar physics modeling
- Dynamical gridding algorithms
- Advanced graphical and parallel processing systems
- Electromagnetic and acoustic scattering
- Microfluidics
- Fluid structure interaction
- Shock and blast containment



Olive (32P) and Snuffy (24P) — Origins at work.

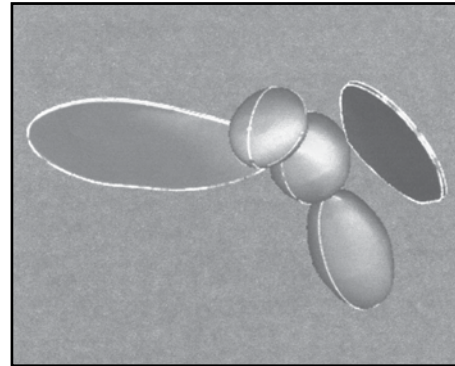

Unstructured grid technology has been used to obtain the surface pressure distribution on a hovering fruit fly *Drosophila*. Such computations are being carried out to gain insights into unsteady force production in nature that may guide in the design of insect-like autonomous air vehicles for the Navy.



This figure shows a contaminant cloud from a FAST3D-CT simulation of downtown Chicago using a $360 \times 360 \times 55$ grid (6 m resolution). A 3 m/s wind off the lake from the left blows contaminant across a portion of the detailed urban geometry. The contaminant is lofted rapidly above the tops of the majority of the buildings due to their geometrical effect.

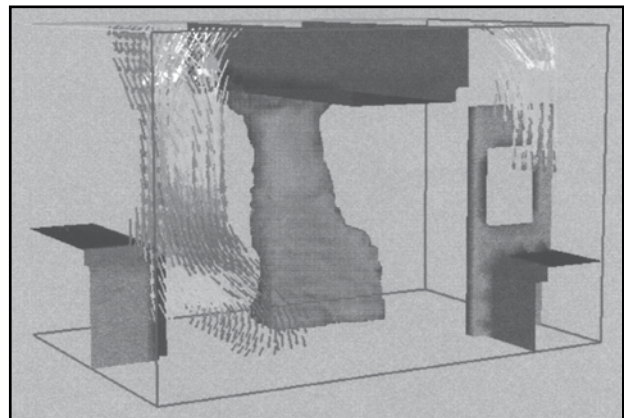

Water-mist trajectories and temperature distributions during the suppression of a fire inside a complex ship compartment. Simulations and experiments have shown that using fine water-mist can significantly reduce the amount of water needed for fire suppression.

Code 6040

Basic Responsibilities

The Laboratories for Computational Physics and Fluid Dynamics (LCP&FD) are responsible for the research leading to and the application of advanced analytical and numerical capabilities that are relevant to NRL, Navy, DoD, and other Government agencies. This research is pursued in the fields of compressible and incompressible fluid dynamics, reactive flows, fluid/structure interactions including submarine and aerospace applications, atmospheric and solar geophysics, magnetoplasma dynamics, application of parallel processing to large-scale problems such as unsteady flows of contaminants in and around cities, advanced propulsion concepts, flame dynamics for shipboard fire safety, jet noise reduction, and other disciplines of continuum computational physics as required to further the overall mission of NRL. The specific objectives of the LCP&FD are to develop and maintain state-of-the-art analytical and computational capabilities in fluid dynamics and related fields of physics; to establish in-house expertise in parallel processing for large-scale scientific computing; to perform analyses and computational experiments on specific relevant problems using these capabilities; and to transfer this technology to new and ongoing projects through cooperative programs with the research Divisions at NRL and elsewhere.

Personnel: 22 full-time civilian

Key Personnel

Title	Code
Director, Laboratories for Computational Physics and Fluid Dynamics	6040
Administrative Officer	6040.2
Chief Scientist for Computational Physics and Fluid Dynamics	6003
Senior Scientist for Reactive Flow Physics	6004
Head, Laboratory for Propulsion, Energetic, and Dynamic Systems	6041
Head, Laboratory for Advanced Computational Physics	6042
Head, Laboratory for Multiscale Reactive Flow Physics	6043

Point of contact: Code 6040.2, (202) 767-6581

Chemistry Division

Code 6100 Research Activity Areas

Chemical Diagnostics

- Optical diagnostics of chemical reactions
- Kinetics of gas phase reactions
- Trace analysis
- Atmosphere analysis and control
- Ion/molecule processes
- Environmental chemistry/microbiology
- Methane hydrates
- Laboratory on a chip
- Alternate energy sources

Materials Chemistry

- Synthesis and evaluation of innovative polymers and composites
- Functional organic coatings
- Polymer characterization
- Magnetic resonance
- Degradation and stabilization mechanisms
- High-temperature resins
- Bio-inspired materials
- Novel nanotubes and nanofibers
- Reactive nanometals

Center for Corrosion Science and Engineering

- Materials failure analysis
- Marine coatings
- Cathodic protection

- Corrosion science
- Environmental fracture and fatigue
- Corrosion control engineering

Surface/Interface Chemistry

- Tribology
- Surface properties of materials
- Surface/interface analysis
- Chemical/biological sensors
- Surface reaction dynamics
- Adhesion
- Bio/organic interfaces
- Diamond films
- Energy storage materials
- Nanostructured materials and interfaces
- Electrochemistry
- Plasmonics
- Synchrotron radiation applications

Safety and Survivability

- Combustion dynamics
- Fire protection and suppression
- Personnel protection
- Modeling and scaling of combustion systems
- Mobility fuels
- Chemometrics/data fusion
- Trace analysis



The Key West site of the NRL Center for Corrosion Science and Engineering specializes in understanding and modeling the marine environment's impact on naval materials. A complete laboratory for the study of corrosion control technologies provides sponsors with prototypical seawater exposure of their systems.



The ex-USS *Shadwell* (LSD 15), moored in Mobile Bay, Alabama, is NRL's full-scale, advanced fire research vessel operated by the Chemistry Division.

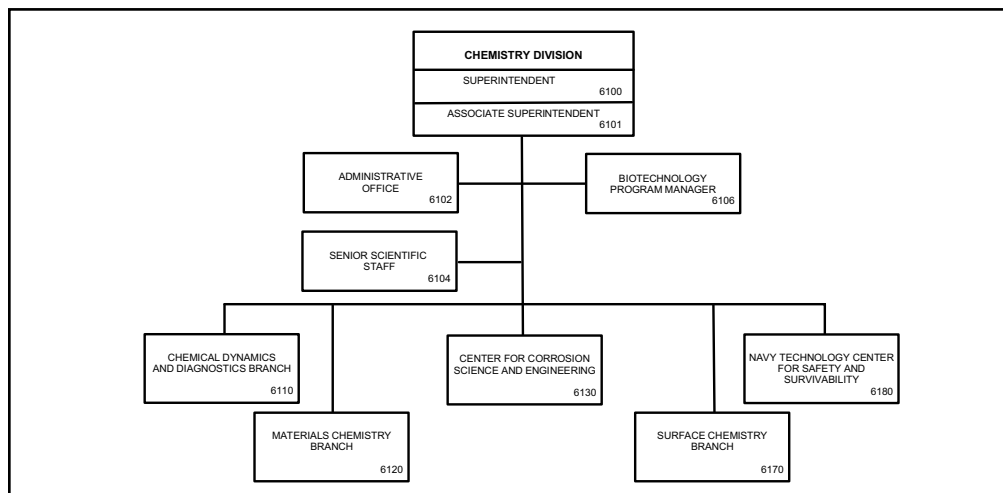

Basic Responsibilities

The Chemistry Division conducts basic research, applied research, and development studies in the broad fields of chemical/structural diagnostics, reaction rate control, materials chemistry, surface and interface chemistry, corrosion passivation, environmental chemistry, and ship safety/survivability. Specialized programs within these fields include coatings, functional polymers/elastomers, clusters, controlled release of energy, physical and chemical characterization of surfaces, electrochemistry, assembly and properties of nano-meter structures, tribology, chemical vapor deposition/etching, atmosphere analysis and control, environmental protection/reclamation, prevention/control of fires, mobility fuels, modeling/simulation, and miniaturized sensors for chemical, biological, trace analysis and data fusion, and explosives.

To enhance protection of Navy personnel and platforms from damage and injury in peace and wartime, the Navy Technology Center for Safety and Survivability performs RDT&E on fire and personnel protection, fuels, chemical defense, submarine atmospheres, and damage control aspects of ship and aircraft survivability; supports Navy and Marine Corps requirements in these areas; and acts as a focus for technology transfer in safety and survivability.

To address problems in corrosion and marine fouling, a Marine Corrosion Facility is located in Key West, Florida. This laboratory resides in an unparalleled site for natural seawater exposure testing and marine related materials evaluation. The tropical climate is ideal for marine exposure testing. Along with the high quality seawater, the location provides small climatic variation and a stable biomass throughout the year.

Personnel: 111 full-time civilian; 2 military; 6 intermittent; 2 part-time

Key Personnel

Title	Code
Superintendent, Chemistry Division	6100
Associate Superintendent	6101
Administrative Officer	6102
Senior Scientific Staff	6104
Senior Scientific Staff	6104
Biotechnology Program Manager	6106
Head, Chemical Dynamics and Diagnostics Branch	6110
Head, Materials Chemistry Branch	6120
Head, Center for Corrosion Science and Engineering	6130
Head, Surface Chemistry Branch	6170
Head, Navy Technology Center for Safety and Survivability	6180

Point of contact: Code 6102, (202) 767-2460

Materials Science and Technology Division

Code 6300 Research Activity Areas

Spintronics

Materials and Sensors

- Superconducting materials
- Magnetic materials
- Optoelectronic materials
- Electroceramic materials
- Radar absorbing materials
- THz sources and detectors
- Bioelectronics
- Remote video surveillance
- Chemical sensors
- Chaos theory
- Thin film deposition
 - Pulsed laser deposition
 - Ion-beam-assisted deposition
 - Variable balance magnetron sputtering
- Laser direct write
- Ion implantation
- Glass fiber draw tower
- Polymer synthesis and characterization
- Precision calorimetry
- Analysis of extrasolar materials
- Ballistic materials
- Personal protective equipment
- Explosives detection

Multifunctional Materials

- Biomechanical surrogate development for threat response characterization
- Biomechanical simulation
- Composite material systems
 - Multifunctional structure + other (e.g., power, etc.)
 - Hierarchical and tiled architectures
 - Armor protection

- Corrosion simulation and control
 - Modeling of electrochemical corrosion systems
 - Evaluation of cathodic protection performance
- Image-based modeling
- Materials by design
- Mesoscale material characterization and simulation
- Physical metallurgy
 - Ferrous, nonferrous, and intermetallic alloys
 - Hot/cold isostatic pressing
 - Micro/nanostructure characterization
 - Three-dimensional microstructure characterization
 - Synthesis/processing of metal
 - Rapid solidification
 - Welding/joining technology
 - Heat treating and phase transformations
- Synthesis and processing of advanced ceramics
 - High energy density dielectrics
 - Piezoelectrics

Computational Materials

- Condensed matter theory
- Electronic structure of solids and clusters
- Molecular dynamics
- Quantum many-body theory
- Theory of magnetic materials
- Theory of alloys
- Semiconductor and surface physics
- Theoretical studies of phase transitions
- Atomic physics theory
- Protein modeling
- Continuum multiphysics modeling



The variable pressure scanning electron microscope facility provides capabilities for imaging down to 10 nm resolution, with both

secondary and backscattered electron detectors. The capability of operating at variable pressures allows for the examination of nonconducting samples without the need for coating. The system is equipped with energy dispersive spectroscopy (EDS) capabilities for measuring, quantifying, and mapping chemical composition, as well as an electron backscattered diffraction (EBSD) camera for the mapping and quantification of material crystallography.

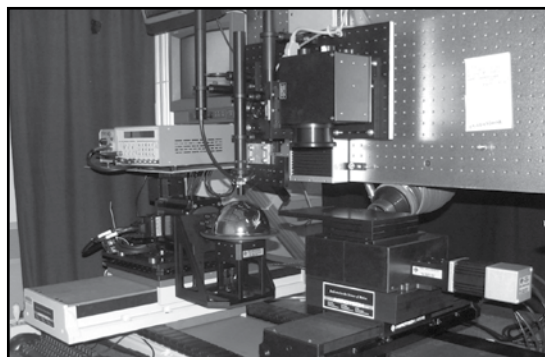

Five-axis laser micromachining and laser direct-write system based on a high-repetition-rate (100 kHz) UV solid-state laser (266 nm). This system can directly deposit and pattern metals and dielectrics on doubly curved surfaces (such as the hemispherical dome shown) with a linewidth resolution down to a few microns and a positional accuracy of one micron.

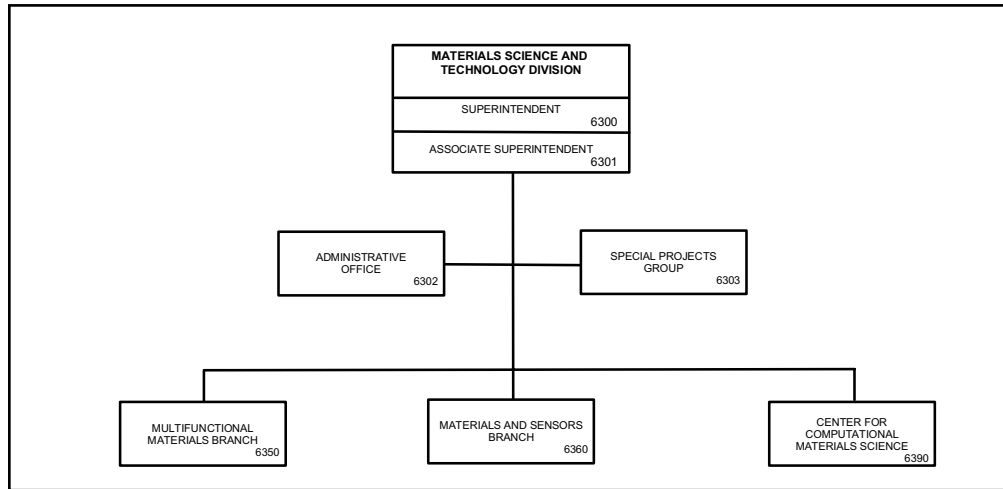

Basic Responsibilities

The Materials Science and Technology Division conducts basic and applied research and engages in exploratory and advanced development of materials having substantive value to the Navy. R&D programs encompass the intrinsic behavior of metals, insulators, composites, and ceramics, including efforts in ferrous alloys, intermetallic compounds, superconducting, dielectric, and magnetic materials, films and coatings, and multifunctional materials systems. The programs encompass advanced synthesis and processing techniques as well as postprocessing techniques to fabricate sensors, devices, structures, and components. A variety of state-of-the-art characterization tools are used to probe the atomic and microstructure nature (composition and structure) of the materials as well as to delineate the fundamental properties of the material or material system. Response of materials and material systems to a variety of external influences (mechanical, chemical, optical, electromagnetic radiation, high-power lasers, temperature, etc.) is integral to the Division's programs, as are performance and reliability projections for military service lifetime. The program includes strong theoretical, computational, and simulation efforts to predict, guide, and explain the behavior of materials and materials systems. Studies conducted in the Division provide guidance for the selection, design, certification, and life-cycle management of material in naval vehicles and systems. The diversity of R&D programs in the Division is carried out by multidisciplinary teams of materials scientists, metallurgists, ceramists, physicists, chemists, and engineers using the most advanced testing facilities and diagnostic techniques.

Personnel: 110 full-time civilian

Key Personnel

Title	Code
Superintendent, Materials Science and Technology Division	6300
Senior Scientist	6300.1
Associate Superintendent	6301
Administrative Officer	6302
Head, Special Projects Group	6303
Head, Multifunctional Materials Branch	6350
Head, Materials and Sensors Branch	6360
Head, Center for Computational Materials Science	6390

Point of contact: Code 6302, (202) 767-2458

Plasma Physics Division

Code 6700

Research Activity Areas

Radiation Hydrodynamics

Radiation hydrodynamics of Z-pinches and laser-produced plasmas
X-ray source development
Cluster dynamics in intense laser fields
X-ray channeling and propagation
Plasma kinetics for directed energy and fusion
Plasma discharge physics
Dense plasma atomic physics, equation of state
Numerical simulation of high-density plasma
Laser driven ion/neutron sources

Laser Plasma

Nuclear weapons stockpile stewardship
Laser fusion, inertial confinement
Megabar high-pressure physics
Rep-rate KrF laser development
Impact fusion
Laser fusion technology
Laser fusion energy
Detection of chemical/biological/nuclear materials

Charged Particle Physics

Applications of modulated electron beams
Rocket, satellite, and shuttle-borne natural and active experiments
Laboratory simulation of space plasma processes

Large-area plasma processing sources
Plasma processing of energy sensitive materials
Atmospheric and ionospheric GPS sensing
Ionospheric effects on communications
Electromagnetic launchers
Radiation belt remediation

Pulsed Power Physics

Production, focusing, and propagation of intense electron and ion beams
High-power, pulsed radiography
Plasma radiator and bremsstrahlung diode sources
Capacitive and inductive energy storage
Nuclear weapons effects simulation
Electromagnetic launchers
Detection of Special Nuclear Materials
Advanced energetics via stimulated nuclear decay

Beam Physics

Advanced accelerators and radiation sources
Microwave, plasma, and laser processing of materials
Microwave sources: magnicons and gyrotrons
Nonlinear dynamics of coupled lasers
Ultrahigh-intensity laser-matter interactions
Free electron lasers and laser synchrotrons
Theory and simulation of space and solar plasmas
Global ionospheric and space weather modeling
Laser propagation in the atmosphere
Underwater laser interactions

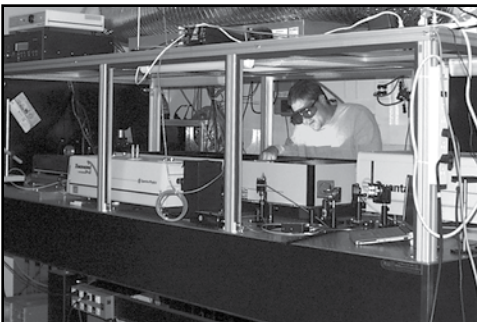

The NRL Ti:Sapphire Femtosecond Laser (TFL) currently operates at 50 fsec, 10 TW and provides a facility to conduct research in intense laser-plasma interactions, ultrashort intense laser propagation in the atmosphere, remote sensing of chem/bio agents, and laser-induced electrical discharges.



Nike is the world's largest krypton fluoride (KrF) laser and is used to explore physics issues for laser fusion. Shown is the propagation bay where 56 short-duration (4-5 ns) beams are directed by mirrors first to the electron-beam-pumped amplifiers and then to the target facility. The Nike KrF system achieves extremely uniform high-intensity illumination of planar targets by overlapping numerous smoothed laser beams. Typical experiments include studies of the ablative acceleration of matter to high velocities (100 km/sec) and studies of the reaction of materials to very high pressures (10 million atmospheres) produced by the laser light.

Nike is the world's largest krypton fluoride (KrF) laser and is used to explore physics issues for laser fusion. Shown is the propagation bay where 56 short-duration (4-5 ns) beams are directed by mirrors first to the electron-beam-pumped amplifiers and then to the

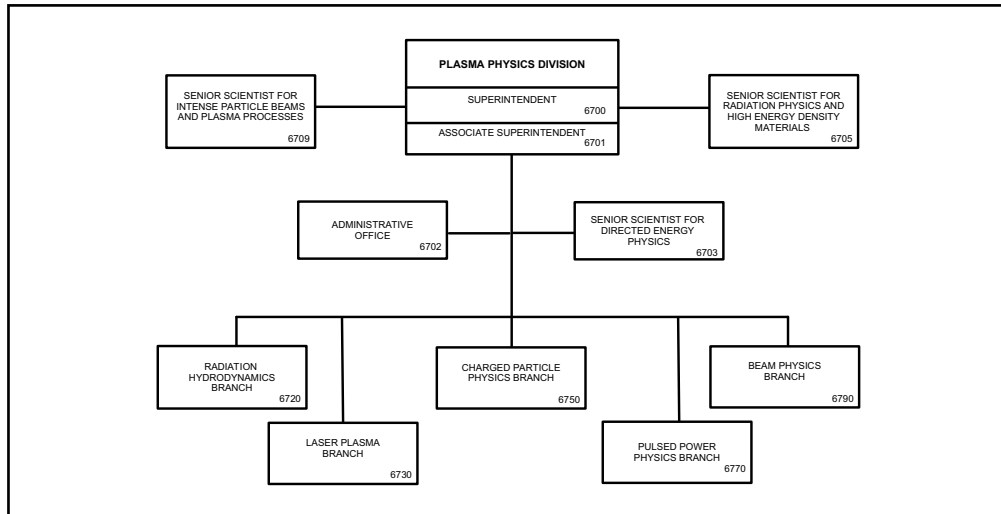

Basic Responsibilities

The Plasma Physics Division conducts a broad theoretical and experimental program of basic and applied research in plasma physics, laboratory discharge, and space plasmas, intense electron and ion beams and photon sources, atomic physics, pulsed power sources, laser physics, advanced spectral diagnostics, and nonlinear systems. The effort of the Division is concentrated on a few closely coordinated theoretical and experimental programs. Considerable emphasis is placed on large-scale numerical simulations related to plasma dynamics; ionospheric, magnetospheric, and atmospheric dynamics; nuclear weapons effects; inertial confinement fusion; atomic physics; plasma processing; nonlinear dynamics and chaos; free electron lasers and other advanced radiation sources; advanced accelerator concepts; and atmospheric laser propagation. Areas of experimental interest include laser-plasma, laser-electron beam, and laser-matter interactions, high-energy laser weapons, laser shock hydrodynamics, thermonuclear fusion, electromagnetic wave generation, the generation of intense electron and ion beams, large-area plasma processing sources, electromagnetic launchers, high-frequency microwave processing of ceramic and metallic materials, advanced accelerator development, inductive energy storage, laboratory simulation of space plasma phenomena, high-altitude chemical releases, and in situ and remote sensing space plasma measurements.

Personnel: 85 full-time civilian

Key Personnel

Title	Code
Superintendent, Plasma Physics Division	6700
Associate Superintendent	6701
Administrative Officer	6702
Senior Scientist, Directed Energy Physics	6703
Senior Scientist, Radiation Physics and High Energy Density Materials	6705
Senior Scientist, Intense Particle Beams and Plasma Processes	6709
Head, Radiation Hydrodynamics Branch	6720
Head, Laser Plasma Branch	6730
Head, Charged Particle Physics Branch	6750
Head, Pulsed Power Physics Branch	6770
Head, Beam Physics Branch	6790

Point of contact: Code 6700, (202) 767-2723

Electronics Science and Technology Division

Code 6800 Research Activity Areas

Electronic Materials

Preparation and development of magnetic, dielectric, optical, and semiconductor materials including micro- and nanostructures
Electrical, optical, and magneto-optical studies of semiconductor microstructures and nanostructures, superlattices, surfaces, and interfaces
Impurity and defect studies
Surface research and interface physics
Theoretical solid-state physics

Microwave Technology

Microwave and millimeter-wave integrated circuits and components research
High-frequency device design, simulation, and fabrication
Reliability and failure physics of electronic devices and circuits
Oxide- and carbon-based electronics for high-frequency devices

Power Electronics

Power device design, simulation, and fabrication
High-voltage/high-temperature power device and components research
Growth and characterization of wide bandgap and thin film materials for power devices
Wafer bonding for power devices and novel substrates
Reliability and failure physics of power devices

Nanoelectronics

Characterization of nanosurfaces and interfaces
Nanoelectronic device research and fabrication
Processing research for nanometric devices

Radiation Effects

Space experiments and satellite survivability
Single event and total ionizing dose effects
Radiation hardening of electronics devices, circuits, and optoelectronic sensors
Ultrafast charge collection
Environmental hazard remediation
Advanced photovoltaic technologies
Femtosecond laser research
Radiation effects in microelectronics and photonics

Solid-State Devices

Solid-state optical sensors
Photovoltaic research and development
Mid- and far-infrared photodiodes/arrays
Microelectronics device research and fabrication
Solid-state circuits research
Signal processing research

Vacuum Electronics

Compact millimeter-wave power amplifier research and development
Cathode research and electron emission science
Materials development for microwave and millimeter-wave applications
Development of microfabrication techniques for upper millimeter-wave devices
Theory and numerical techniques for modeling of fast-wave and slow-wave devices
Techniques for broadband, complex waveform generation and analysis for high data rate communications and electronic warfare

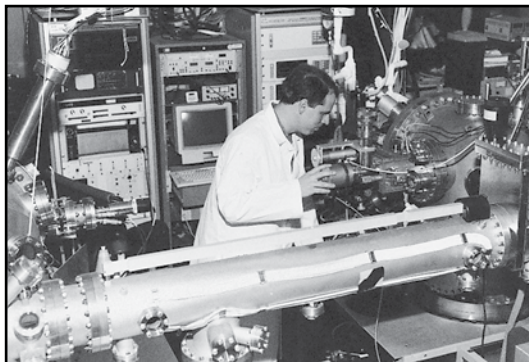

The EPICENTER specializes in molecular beam epitaxial growth of nanostructures created by alternating layers of narrow bandgap materials made available from four ultrahigh-vacuum chambers. These structures are expected to improve the performance of far-infrared detectors, midwave lasers, and superhigh frequency transistors and resonant tunneling diodes. Here a scientist creates a structure using high-vacuum, chamber-to-chamber sample transfer.

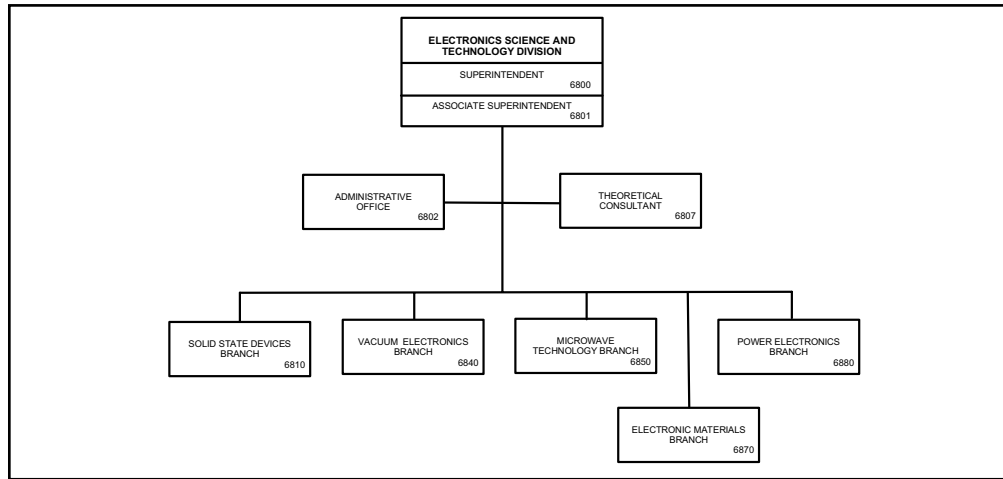

Basic Responsibilities

The Electronics Science and Technology Division conducts programs of basic science and applied research and development in materials growth and properties, surface physics, micro- and nanostructure electronics, microwave techniques, microelectronic device research and fabrication, vacuum electronics, and cryoelectronics, including superconductors. The activities of the Division integrate device research with basic materials investigations and with systems research and development needs.

Personnel: 98 full-time civilian

Key Personnel

Title	Code
Superintendent, Electronics Science and Technology Division	6800
Associate Superintendent	6801
Administrative Officer	6802
Senior Scientist for Nanoelectronics	6877
Head, Solid State Devices Branch	6810
Head, Vacuum Electronics Branch	6840
Head, Microwave Technology Branch	6850
Head, Electronic Materials Branch	6870
Head, Power Electronics Branch	6880

Point of contact: Code 6802, (202) 767-3416

Center for Bio/Molecular Science and Engineering

Code 6900 Research Activity Areas

Biologically Derived Microstructures

- Self-assembly, molecular machining
- Synthetic membranes
- Nanocomposites
- Tailored electronic materials
- Low observables
- Molecular engineering, biomimetic materials
- Molecular imprinting
- Viral scaffolds
- Multifunctional decontamination coatings

Biosensors

- Binding polypeptides and proteins
- Cell-based biosensors
- DNA biosensors
- Fiber-optic biosensors
- Flow immunosensors
- Array-based sensors
- Optical biosensors
- Microfluidics

Novel Materials

- Soil/groundwater explosives detection
- Antifouling paint, controlled release
- Single chain antibodies
- Liquid crystal nanoparticles
- Liquid crystal elastomers
- Nano- and mesoporous materials
- Quantum dot and protein conjugates
- Biomimetic materials

Molecular Biology

- Genomics and proteomics of marine bacteria
- Tissue engineering
- Gene arrays, biomarkers
- System and synthetic biology

Energy Harvesting

- Biomaterials for charge storage
- Ocean floor biofuel cell
- Photo-induced electron transfer

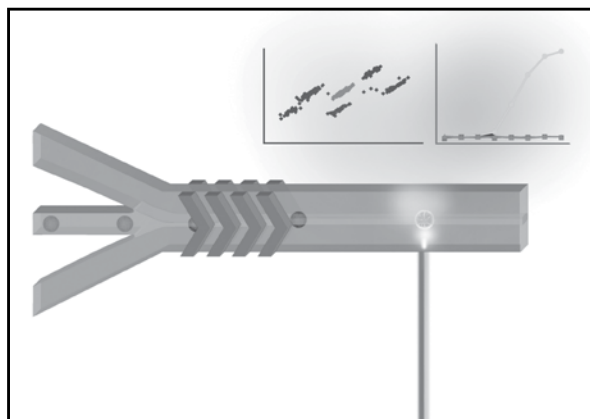

Microfluidic structures direct arrays of beads one-by-one past a laser beam. If a biothreat is bound to the surface of a bead, the identity of the threat can be determined by the color code on the bead.

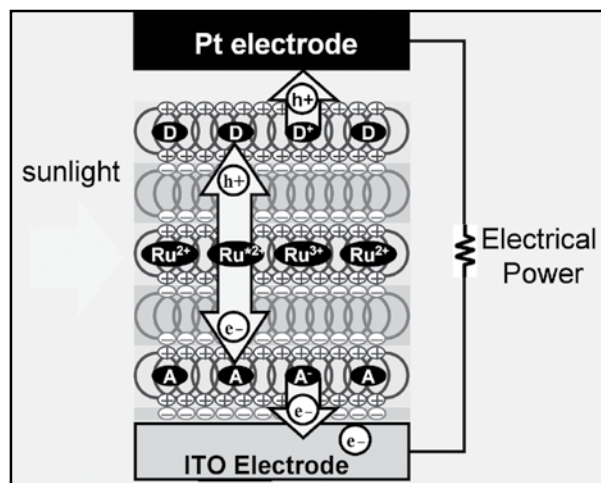

Utilizing the self-assembly of molecular chromophores, electron acceptors, and electron donors to investigate non-silicon-based methods for electricity generation from sunlight.

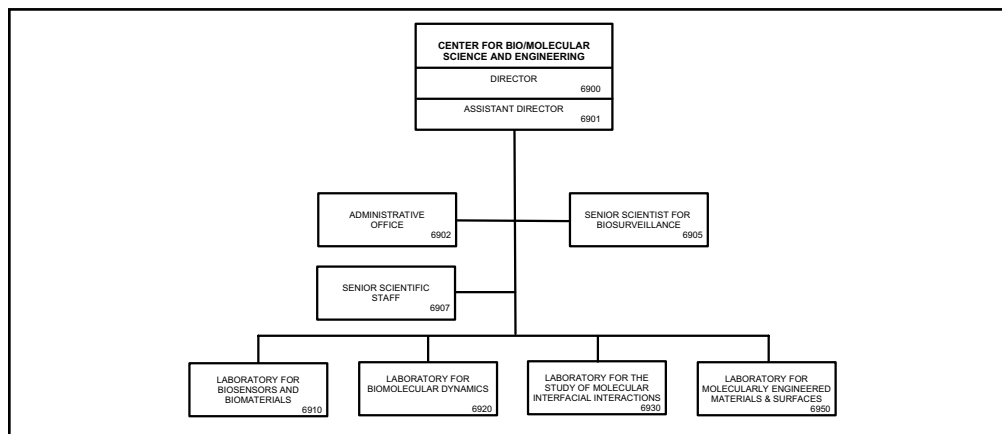

Basic Responsibilities

The Center for Bio/Molecular Science and Engineering is using the tools of modern biology, physics, chemistry, and engineering to develop advanced materials and sensors. The long-term research goal is first to gain a fundamental understanding of the relationship between molecular architecture and the function of materials, then apply this knowledge to solve problems for the Navy and DoD community. The key theme is the study of complex bio/molecular systems with the aim of understanding how “nature” has approached the solution of difficult structural and sensing problems. Technological areas currently being studied include molecular and microstructure design, molecular biology, self-assembly, controlled release and encapsulation, and surface patterning and modification. Much of the research deals with the self-assembly of lipids, proteins, and liquid crystals into complex microstructures for use in advanced material applications, and the harnessing of the recognition functions of proteins and cells for the development of advanced sensors. A highly multidisciplinary staff is required to pursue these research and development programs. The Center provides a stimulating environment for cross-disciplinary programs in the areas of immunology, biochemistry, electrochemistry, inorganic and polymer chemistry, microbiology, microlithography, photochemistry, biophysics, spectroscopy, advanced diagnostics, organic synthesis, and electro-optical engineering.

Personnel: 57 full-time civilian

Key Personnel

Title	Code
Director, Center for Bio/Molecular Science and Engineering	6900
Assistant Director	6901
Administrative Officer	6902
Senior Scientist for Biosurveillance	6905
Head, Senior Scientific Staff	6907
Head, Laboratory for Biosensors and Biomaterials	6910
Head, Laboratory for Biomolecular Dynamics	6920
Head, Laboratory for the Study of Molecular Interfacial Interactions	6930
Head, Laboratory for Molecularly Engineered Materials and Surfaces	6950

Point of contact: Code 6902, (202) 404-6012

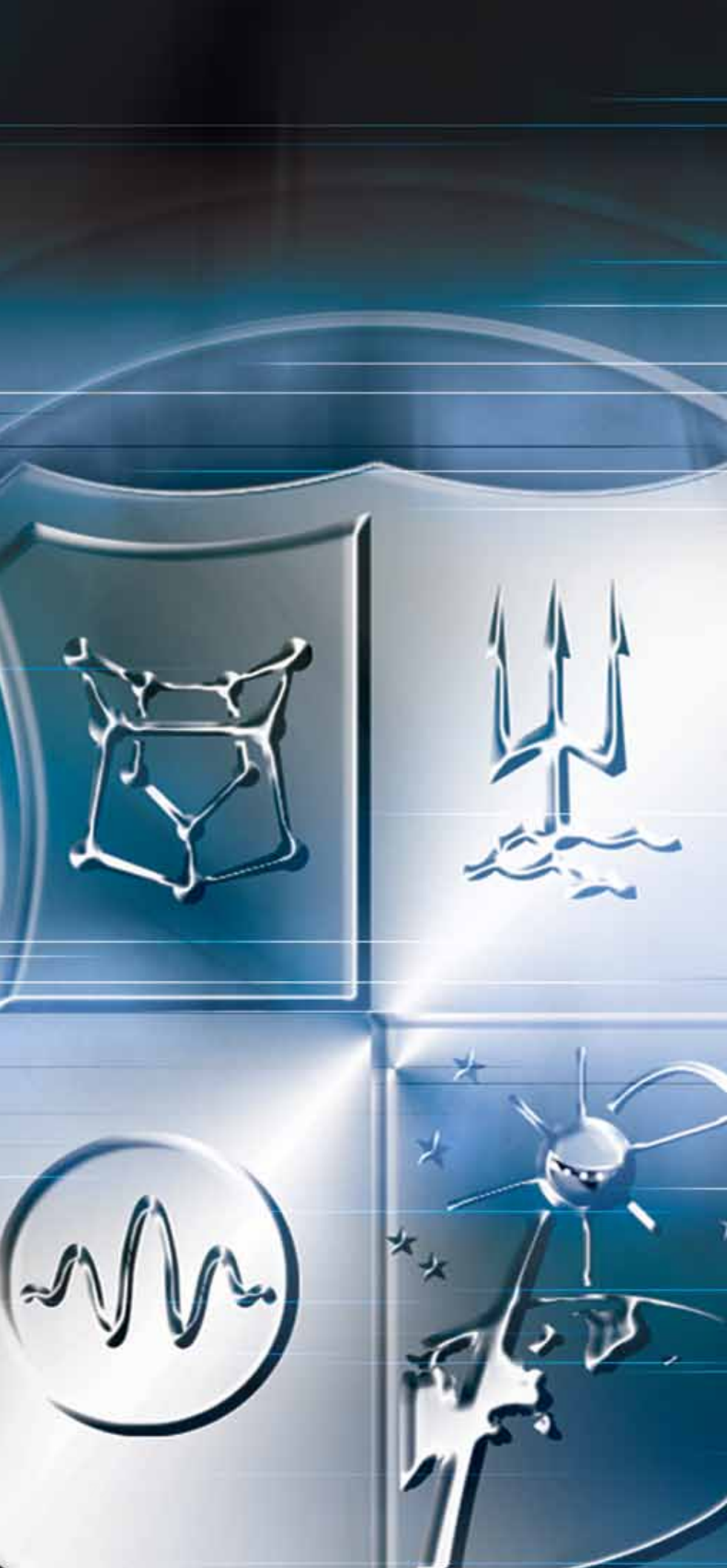

**Ocean and
Atmospheric
Science and
Technology
Directorate**

OCEAN AND ATMOSPHERIC SCIENCE AND TECHNOLOGY DIRECTORATE

Code 7000

The Ocean and Atmospheric Science and Technology Directorate performs research and development in the fields of acoustics, remote sensing, oceanography, marine geosciences, marine meteorology, and space science. Areas of emphasis in acoustics include advanced acoustic concepts and computation, acoustic signal processing, physical acoustics, acoustic systems, ocean acoustics, and acoustic simulation and tactics. Areas of emphasis in remote sensing include radio, infrared, and optical sensors, remote sensing physics and hydrodynamics, remote sensing simulation, and imaging systems. Areas of emphasis in oceanography include coastal and open ocean dynamics, ocean modeling and prediction, coastal and open ocean processes, remote sensing applications to oceanography, and marine biocorrosion processes. Areas of emphasis in marine geosciences include

marine physics, seafloor sciences, geospatial information science and technology, and mapping, charting, and geodesy. Areas of emphasis in marine meteorology include atmospheric dynamics for theater-wide, tactical-scale prediction systems and forecast support, and meteorological applications development. Areas of emphasis in space science include middle and upper atmosphere physics, solar terrestrial relationships, solar physics, and higher energy astronomy. Senior naval officers are assigned as military advisors to help maintain the directorate focus on operational Navy and other DoD requirements in these areas of emphasis. The directorate is responsible for administrative and technical support to major activities in Washington, DC; Stennis Space Center, Mississippi; and Monterey, California.

Associate Director of Research for Ocean and Atmospheric Science and Technology

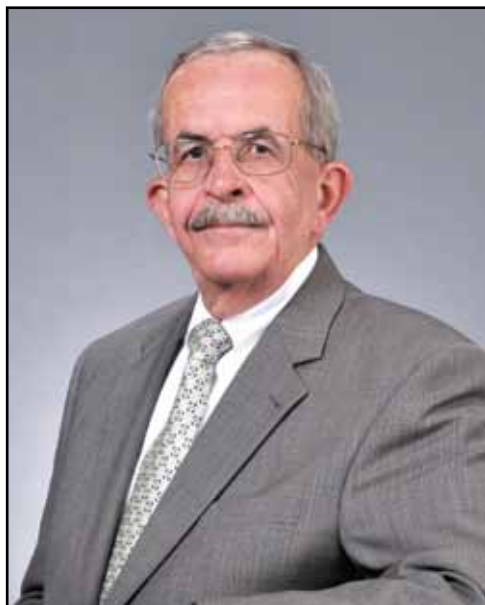

Dr. E.R. Franchi was born in Huntington, New York. He graduated from Clarkson University in 1968 with a bachelor of science degree in mathematics. He received his master of science (1970) and Ph.D. (1973) degrees, both in applied mathematics, from Rensselaer Polytechnic Institute. After completing his graduate studies, Dr. Franchi accepted a research position with Bolt, Beranek, and Newman where he performed validation studies of underwater acoustic propagation and noise models.

Dr. Franchi joined the Naval Research Laboratory in 1975 as a research mathematician in the Acoustics Division. In this position, he conducted and directed research in low frequency acoustic reverberation and scattering, including design and conduct of field experiments, development of signal processing techniques, data analysis and interpretation, computer prediction models, and active sonar performance studies. In 1986, he was named Head of the Acoustic Systems Branch where he was responsible for programs that emphasized theoretical, experimental, and computational research to understand the physical mechanisms of acoustic propagation, scattering, and ambient noise that control the design and performance of large-aperture passive sonar

systems, low frequency active sonar systems, and shallow water sonar systems.

In July 1988, Dr. Franchi was appointed to the Senior Executive Service and selected as the Associate Technical Director of the Naval Ocean Research and Development Activity (NORDA) and its Director of Ocean Acoustics and Technology. The Directorate conducted basic, exploratory, and advanced research and development and program management in the areas of acoustic model development and simulation, ocean acoustics measurements, and ocean engineering in support of all undersea warfare missions. In October 1992, the Directorate became the Center for Environmental Acoustics in the Acoustics Division of the Naval Research Laboratory, with Dr. Franchi as Director. Dr. Franchi was selected to the position of Superintendent of the Acoustics Division in October 1993. The Acoustics Division conducts basic, exploratory, and applied research and development in areas of acoustic modeling and simulation, ocean acoustics measurements, acoustic systems development, acoustic signal processing, and physical acoustics. He was responsible for the technical/scientific management, direction, and administration of programs with a total budget in excess of \$25M, and for efficient management of division resources including the activities of approximately 110 civilian personnel. He served as Acting Associate Director of Research for the Ocean and Atmospheric Science and Technology Directorate from October 2001 to May 2002 and from June 2007 to April 2008. In April 2008, he was selected as the Associate Director of Research.

Dr. Franchi received the Presidential Rank Award of Meritorious Executive in 2003. He has over 35 years experience in underwater acoustics research and is the author/co-author of over 35 publications. He is recognized as an authority on underwater acoustic scattering and reverberation and has played major roles in Navy low frequency active sonar programs as both performer and advisor/consultant. He served as the U.S. National Leader of The Technical Cooperation Program's multinational Panel on ASW Systems and Technology from 1996 to 2002, and served as its Panel Chairman from 2002 to 2009. In 2011, Dr. Franchi received the TTCP Personal Achievement Award in recognition of his significant contributions and strategic vision in leading the ASW Panel. He represents the United States to the NATO Undersea Research Centre Scientific Committee of National Representatives and served as its Committee Chairman from 2010 to the present. In 2011, he was appointed to the NATO Science and Technology Reform Implementation Team. He was elected to Pi Mu Epsilon, the Honorary National Mathematics Society, while an undergraduate at Clarkson University. Dr. Franchi is a member of the Acoustical Society of America and past member of the Mathematical Association of America. Since 2004, he has volunteered his time to serve on the Board of Directors of the NRL Federal Credit Union.

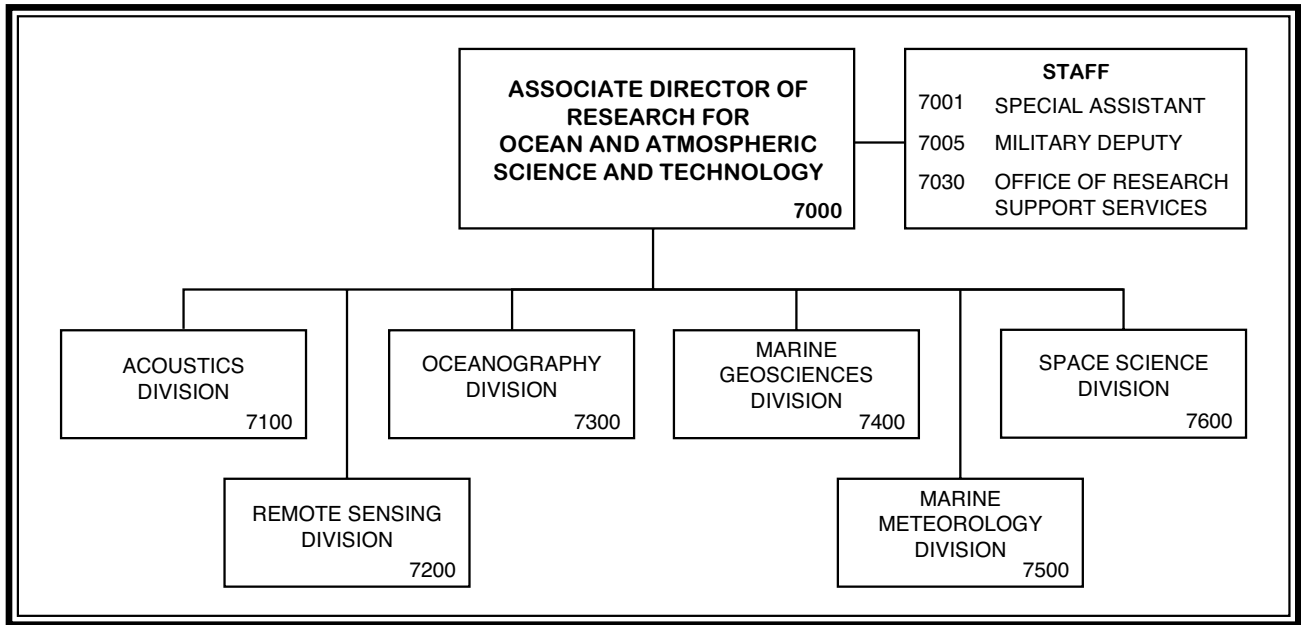

Key Personnel

Title	Code
Associate Director of Research for Ocean and Atmospheric Science and Technology	7000
Special Assistant	7001
Military Deputy	7005
Head, Office of Research Support Services	7030
Superintendent, Acoustics Division	7100
Superintendent, Remote Sensing Division	7200
Superintendent, Oceanography Division	7300
Superintendent, Marine Geosciences Division	7400
Superintendent, Marine Meteorology Division	7500
Superintendent, Space Science Division	7600

Point of contact: Code 7000A, (202) 404-8174

Office of Research Support Services (NRL-SSC)

Code 7030 Staff Activity Areas

Office of Research Support

Conference coordination, video teleconferencing
Directives, reports, forms

Facilities Office

Facilities planning and maintenance
Vehicles

HPC Management Office

Supercomputing interface management

Safety/Environmental Office

Industrial/laboratory safety
Specialized safety training
Hazard abatement
Mishap prevention
Hazardous materials program
Hazardous waste disposal

Public Affairs Office

Community relations
News releases
Exhibits
Information
Freedom of Information Act

NRL-SSC Network Management Office

Data communications
Data networking
Computer network maintenance

Code 7030

Basic Responsibilities

The Office of Research Support Services is responsible for the operational and management support necessary for the day-to-day operations at NRL Stennis Space Center, Mississippi (NRL-SSC). The Head of NRL-SSC acts for the Commanding Officer in dealing with local Navy, Federal, and civil activities and personnel on matters relating to NRL-SSC support activities and facilities, community and multicommand issues, and safety and disaster control measures.

Support functions include public affairs, network support, safety, high performance computer management, and support services to include management, administration, and facilities.

Personnel: 8 full-time civilian

Key Personnel

Title	Code
Head, Office of Research Support Services	7030
Administrative Officer	7030.2
Head, Facilities Office	7030.3
Public Affairs Officer	7030.4
Safety / Environmental Officer	7030.5
HPC Management Office	7030.6
NRL-SSC Network Management Office	7030.8

Point of contact: Code 7030, (228) 688-4010; DSN 828-4010

Acoustics Division

Code 7100 Research Activity Areas

Physical Acoustics

- Structural acoustics
- Quantum effects in phononic crystals
- Nanomechanical devices
- Fiber-optic acoustic sensors
- Acoustic transduction
- Inverse scattering
- Target strength/radiation modeling
- Flow-induced noise and vibration
- Active sonar classification
- Underwater distributed, networked sensing
- AUV-based sensing



At-sea deployment of underwater acoustic communications source/receiver array. The purpose is to conduct multiple-input-multiple-output (MIMO) underwater acoustic communications experiments to increase the bandwidth for distributed systems.

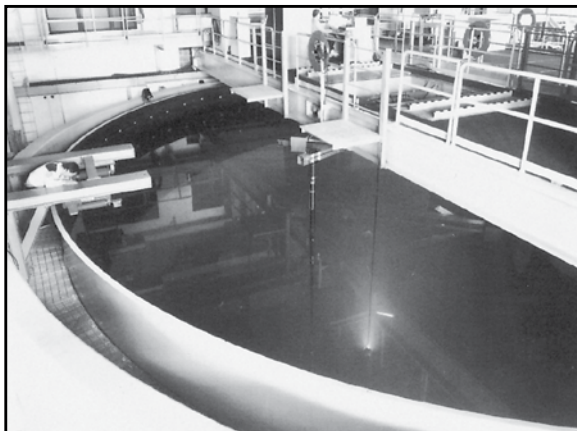

Structural acoustic studies are conducted in the one-million-gallon Acoustic Holographic Pool Facility.

Acoustic Signal Processing and Systems

- Underwater acoustic communications and networking
- Limits of array performance
- Waveguide invariant processing
- Acoustic field uncertainty
- Acoustic interactions with transonic/supersonic flows
- Acoustic noise forecasting
- Long-range underwater communications
- Underwater distributed sensing networks
- Ocean boundary scattering
- Acoustic propagation
- Acoustic inversion
- Characterization of reverberation
- Acoustic metamaterials
- Acoustics of microfluidic bubbly emulsions
- Active sonar performance modeling
- Compressive sensing
- Acoustic classification
- Nonlinear propagation
- Underwater acoustic network warfare

Acoustic Simulation, Measurements, and Tactics

- Ocean acoustic propagation and scattering models
- Fleet application acoustic models
- High-frequency seafloor and ocean acoustic measurements
- Riverine acoustics
- Distributed sensing networks
- Incorporating uncertainty in predictive models
- Tactical acoustic simulations and databases
- Warfare effectiveness studies and optimization
- Environmental assessment and planning tools

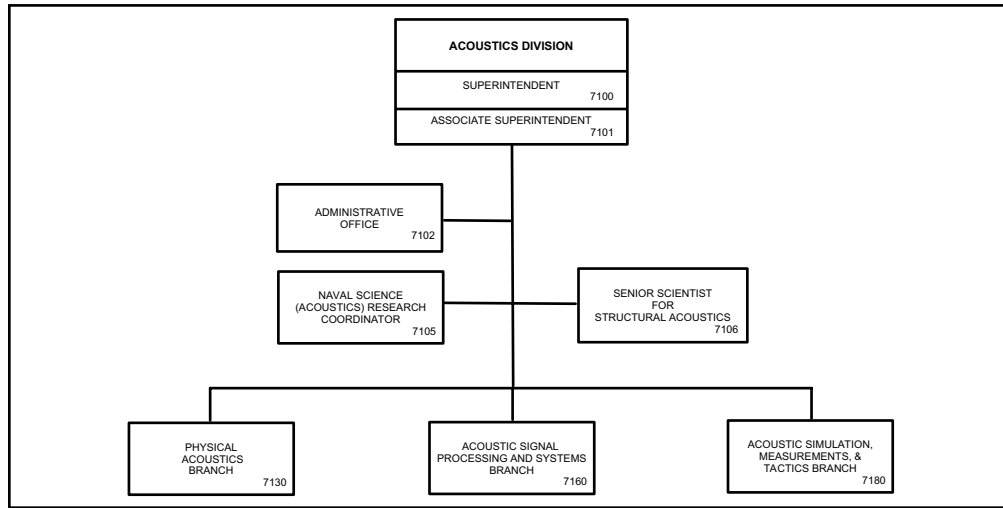

Basic Responsibilities

The Acoustics Division conducts basic and applied research addressing the physics of acoustic signal generation, propagation, scatter, and detection with the objective of improving the strategic and tactical capabilities of the Navy and Marine Corps in the ocean and land operational environment. The Division's scientists and engineers perform collaborative research with scientists affiliated with national and international academic, private, and governmental research organizations. The Division's research spans classical and quantum physics, signal processing, the impact of fluid dynamics on the oceans sound speed field, the propagation and scatter of acoustic signals in the ocean and land environments, structural and physical acoustics including the development of MEMS and nanotechnology based sensors, and the application of networked unmanned underwater vehicles and associated sensors to the Navy's ASW, MCM, and ISR missions.

Personnel: 77 full-time civilian

Key Personnel

Title	Code
Superintendent, Acoustics Division	7100
Associate Superintendent	7101
Administrative Officer	7102
Naval Science (Acoustics) Research Coordinator	7105
Senior Scientist for Structural Acoustics	7106
Head, Physical Acoustics Branch	7130
Head, Acoustic Signal Processing and Systems Branch	7160
Head, Acoustic Simulation, Measurements, and Tactics Branch	7180

Point of contact: Code 7100, (202) 767-3482

Remote Sensing Division

Code 7200

Research Activity Areas

Remote Sensing

Sensors

SAR

Imaging radar

Passive microwave imagers

CCDs and focal plane arrays

Thermal IR cameras

Fabry-Perot spectrometers

Imaging spectrometers

Radio interferometers

Optical interferometers

Adaptive optics

Lidar

Spaceborne and airborne systems

Research Areas

Radiative transfer modeling

Coastal oceans

Marine ocean boundary layer

Polar ice

Middle atmosphere

Global ocean phenomenology

Environmental change

Ocean surface wind vector

Soil moisture

Ionosphere

Data assimilation

Astrophysics

Optical interferometry

Radio interferometry

Fundamental astrometry and reference frames

Fundamental astrophysics

Star formation

Stellar atmospheres and envelopes

Interstellar medium,
interstellar scattering
pulsars

Low-frequency
astronomy

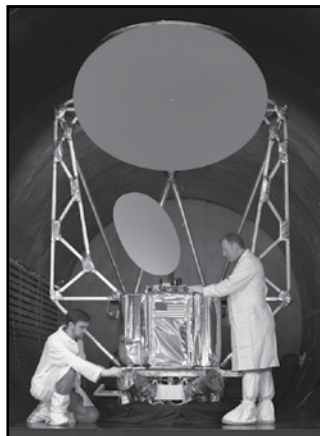

The WindSat polarimetric radiometer prior to spacecraft integration.

Physics of Atmospheric/Ocean Interaction

Mesoscale, fine-structure, and microstructure

Aerosol and cloud physics

Mixed layer and thermocline applications

Sea-truth towed instrumentation techniques

Turbulent jets and wakes

Nonlinear and breaking ocean waves

Stratified and rotating flows

Turbulence modeling

Boundary layer hydrodynamics

Marine hydrodynamics

Computational hydrodynamics

Imaging Research/Systems

Remotely sensed signatures analysis/simulation

Real-time signal and image processing
algorithm/systems

Image data compression methodology

Image fusion

Automatic target recognition

Scene/sensor noise characterization

Image enhancement/noise reduction

Scene classification techniques

Radar and laser imaging systems studies

Coherent/incoherent imaging sensor exploitation

Numerical modeling simulation

Environmental imagery analysis

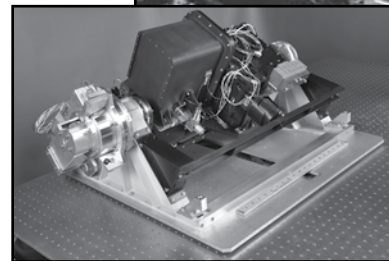
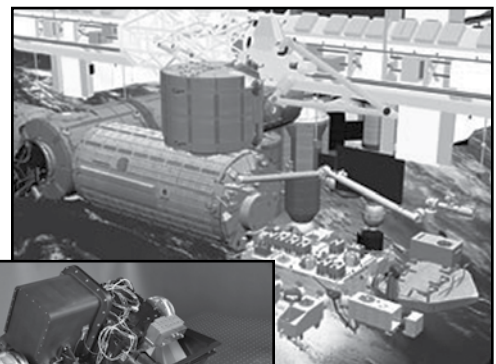

The Hyperspectral Imager for the Coastal Ocean, or HICO, is optimized to image the coastal ocean and adjacent land in 128 contiguous color bands. This spectral data is used to develop maps of water depth, water optical properties, land vegetation, and soil bearing strength. HICO was deployed to the International Space Station in September 2009, providing scientific imagery of varied coastal types worldwide.

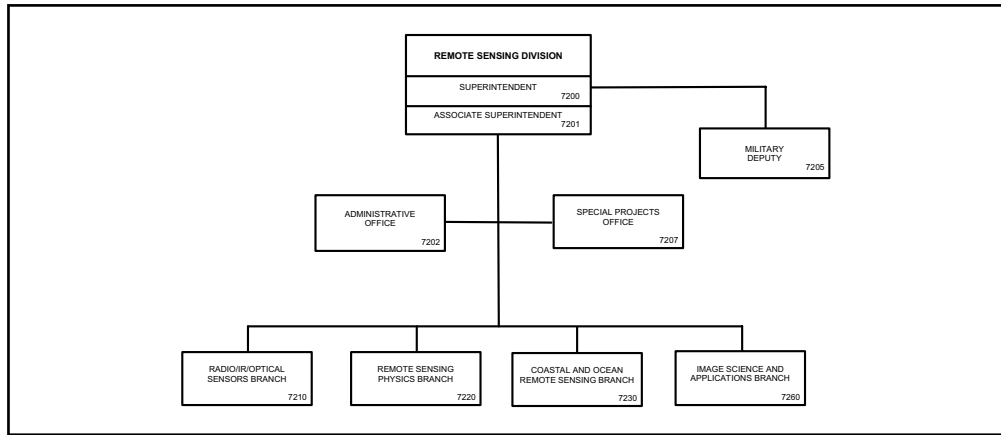

Basic Responsibilities

The Remote Sensing Division is the Navy's center of excellence for remote sensing research and development, conducting a program of basic research, science, and applications aimed at the development of new concepts for sensors and imaging systems for objects and targets on the Earth, in the near-Earth environment, and in deep space. The research, both theoretical and experimental, deals with discovering and understanding the basic physical principles and mechanisms that give rise to target and background emission and to absorption and emission by the intervening medium. The accomplishment of this research requires the development of sensor systems technology. This development effort includes active and passive sensor systems to be used for the study and analysis of the physical characteristics of phenomena that give rise to naturally occurring background radiation, such as that caused by the Earth's atmosphere and oceans, as well as man-made or induced phenomena, such as ship/submarine hydrodynamic effects. The research also includes theory, laboratory, and field experiments leading to ground-based, airborne, and space-based systems for use in such areas as environmental remote sensing (including improved meteorological support systems for the operational Navy), astrometry, astrophysics, surveillance, and nonacoustic ASW. Special emphasis is given to developing space-based platforms and exploiting existing space systems.

Personnel: 97 full-time civilian

Key Personnel

Title	Code
Superintendent, Remote Sensing Division	7200
Associate Superintendent	7201
Administrative Officer	7202
Military Deputy	7205
Head, Radio/Infrared/Optical Sensors Branch	7210
Head, Remote Sensing Physics Branch	7220
Head, Coastal and Ocean Remote Sensing Branch	7230
Head, Image Science and Applications Branch	7260

Point of contact: Code 7200, (202) 767-3391

Oceanography Division

Code 7300 Research Activity Areas

Ocean Dynamics and Prediction

Circulation

- Global resolution of circulation and meso-scale fields
- Littoral circulation at the coast, bays, and estuaries
- Satellite observation processing and assimilation
- UUV adaptive sampling
- Observation system simulation experiments
- Ice volume and ice drift
- Tidal currents and heights

Surface effects

- Surface wave effects globally and into bays
- Wave breaking
- Mixed layer dynamics
- Swell propagation and dynamics
- Phase averaged wave evolution
- Phase resolved wave dynamics

Nearshore

- Wave breaking at the shore
- Rip currents at the shore
- Tidal currents and heights into rivers
- Nonlinear wave interaction
- Sensor deployment optimization

Acoustic effects

- Sound speed variation for acoustic propagation
- Internal waves, solitons, and bores for beam focusing
- Wave bubble entrainment and noise generation

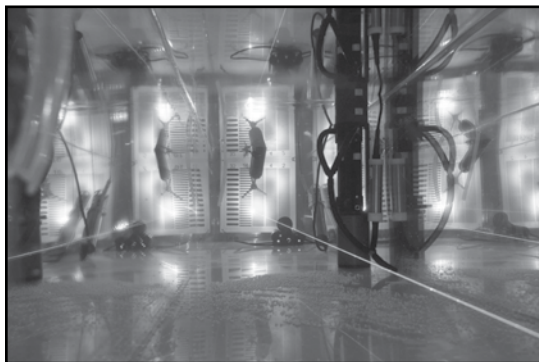

Rayleigh Bernard Convective Tank provides a controlled environment capable of generating turbulent microstructures at various repeatable intensities.

Ocean Sciences

Dynamical processes

- Optical turbulence
- Biological sensing and modeling
- Optical thin layers
- Coastal current systems
- Waves and bubbles

Coupled systems

- Air/ocean/acoustic coupling
- Coupled bio/optical/physical processes
- Coupled physical/sediment processes

Remote sensing applications

- 3D optical profiling
- Color/hyperspectral signatures
- Ocean optics
- Sea surface salinity
- Microbiologically influenced corrosion
- Metal-microbe interaction

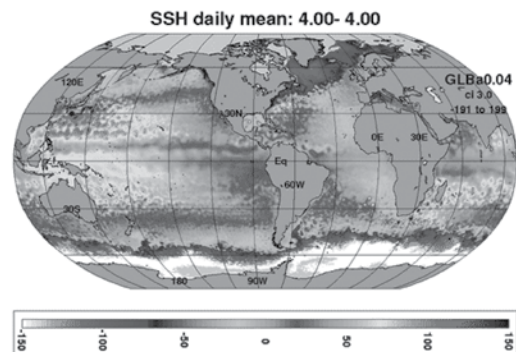

Global sea surface height from the 1/25° Hybrid Coordinate Ocean Model (HYCOM) including ice cover.



Environmental scanning electron microscope with focused ion beam (ESEM/FIB) coupled with an energy dispersive X-ray detector.

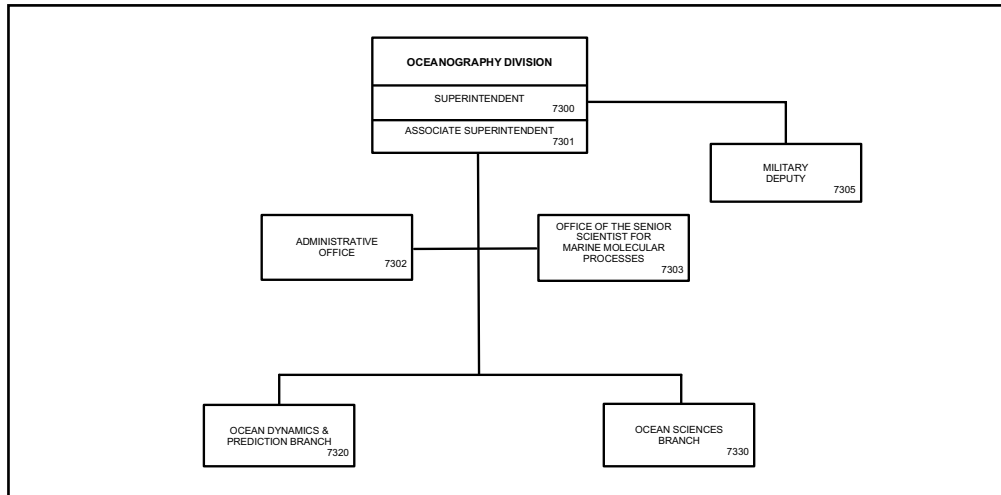

Basic Responsibilities

The Oceanography Division conducts basic and applied research in description and modeling of biological, physical, and dynamical processes in open ocean, regional, and littoral areas; in exploitation of satellite, airborne, and in situ sensors for environmental characterization; and in investigation and application of microbial processes to Navy problems. The oceanographic research is both theoretical and experimental in nature and is focused on understanding and modeling ocean, coastal, and littoral area hydro/thermodynamics, circulation, waves, ice dynamics, air-sea exchange, optics, and small and microscale processes. Analytical methods and algorithms are developed to provide quantitative retrieval of geophysical parameters of Navy interest from state-of-the-art sensor systems. The Division work includes analysis of biological processes that mediate and control optical properties of the oceans, coastal, and littoral regions, and microbially induced corrosion/metal-microbe interaction. The Division programs are designed to be responsive to and to anticipate Naval needs. Transition of Division products to the DoD, Navy systems developers, operational Navy, and civilian (dual use) programs is a primary goal. The Division's programs are coordinated and interactive with other NRL programs and activities, ONR's research programs, and other government agencies involved in oceanographic activities. The Division also collaborates and cooperates with scientists from the academic community and other U.S. and foreign laboratories.

Personnel: 86 full-time civilian; 1 military

Key Personnel

Title	Code
Superintendent, Oceanography Division	7300
Associate Superintendent	7301
Administrative Officer	7302
Office of the Senior Scientist for Marine Molecular Processes	7303
Military Deputy	7305
Head, Ocean Dynamics and Prediction Branch	7320
Head, Ocean Sciences Branch	7330

Point of contact: Code 7301, (228) 688-4704; DSN 828-4704

Marine Geosciences Division

Code 7400 Research Activity Areas

Marine Geology

- Sedimentary processes
- Sediment microstructure
- Pore fluid flow
- Diapirism, volcanism, faulting, mass movement
- Biogenic and thermogenic methane
- Hydrate distribution, formation, and dissociation
- Small-scale granular/fluid dynamics

Marine Geophysics

- Seismic wave propagation
- Physics of low-frequency acoustic propagation
- Acoustic energy interaction with topography and inhomogeneities
- Gravimetry and geodesy
- Geomagnetic modeling

Marine Geotechnique

- Acoustic seafloor characterization
- Geoacoustic modeling
- Geotechnical properties and behavior of sediments
- Measurement and modeling of high-frequency acoustic propagation and scattering
- Mine burial processes
- Marine biogeochemistry
 - Animal-microbe-sediment interactions
 - Early sediment diagenesis
- Biom mineralization of palladium species
- Physics-based and numerical modeling of sediment strength

Geospatial Sciences and Technology

- Digital database design
- Digital product analysis and standardization
- Data compression techniques and exploitation
- Hydrographic survey techniques
- Bathymetry extraction techniques from remote and acoustic imagery
- Modeling of nearshore morphodynamics
- Geospatial portal design with 2D and 3D interfaces
- Characterization of the littoral from airborne platforms

In Situ and Laboratory Sensors

- High-resolution seafloor 2D and 3D seismic imaging
- Laser/hyperspectral bathymetry/topography
- Swath acoustic backscatter imaging
- Sediment pore water pressure, permeability, and undrained shear strength
- Compressional and shear wave velocity and attenuation
- Airborne geophysics, gravity, and magnetics
- Seafloor magnetic fluctuation
- Sediment microfabric change with pore fluid and/or gas change
- Instrumented mine shapes
- Bottom currents and pressure fluctuations

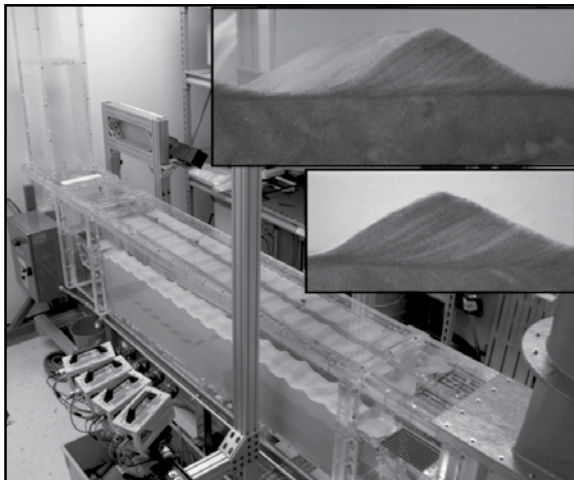

In the Marine Geosciences Division, scientists perform laboratory experiments with a small oscillatory flow tunnel (S-OFT) to study the formation and migration of sand ripples. Rippled sand beds are ubiquitous on the seafloor in shallow water. Understanding the complex response of the seafloor to forcing from surface waves and currents is important for Naval operations from amphibious landings to mine warfare. Shown in the image is the S-OFT including a mounted laser and four high-speed video cameras to perform tomographic particle image velocimetry (Tomo-PIV) measurements, which estimate the three-dimensional fluid velocity in a volume up to 10 cm³. The upper inset is a picture of a sand ripple formed using a bimodal distribution of sand where the smaller sand particles are darker and the larger sand particles are lighter in color. The lower inset is a profile image of a sand ripple from the same experiment where the sorting processes between large and small grains have formed visible strata. Ripple migration is from right to left in both inset images.

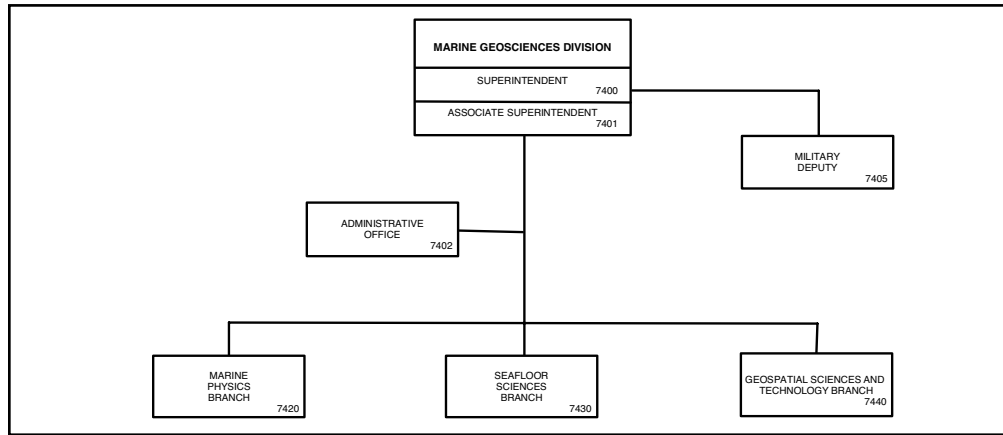

Basic Responsibilities

The Marine Geosciences Division conducts a broadly based, multidisciplinary program of scientific research, advanced technology development, and applied research in marine geosciences, geodesy, geospatial information, and related technologies. This includes investigations of basic processes within ocean basins, littoral regions and adjacent land areas, and arctic regions; development of models, sensors, and techniques; and the exploitation of this knowledge and technology to enhance Navy and Marine Corps systems, plans, and operations, and to meet national needs.

As the Navy's subject matter expert in the areas of Geospatial Information and Services (GI&S), the Division provides vital technical support to the Oceanographer/Navigator of the Navy, CNO, N2/N6F5, the National Geospatial-Intelligence Agency (NGA) and the Tri-Service Community. NRL also contributes to the development of leading-edge geospatial technology by reviewing emerging GI&S standards and products.

Close coordination and interactions with the Commander, Naval Meteorology and Oceanography Command, Naval Oceanographic Office, CNO, Office of Naval Research (ONR), Systems Commands, Warfare Centers, NGA, and the other DoD and national organizations are essential to the success of Division programs, with transition of Division technology to systems developers and to the operational Navy a primary goal. The Division program is coordinated and interactive with other NRL programs and activities, ONR's Research Program Department, NOAA, USGS, NSF, and other government agencies involved in seafloor activities. The Division collaborates and cooperates with scientists from the academic community, other U.S. and foreign laboratories, and industry.

Personnel: 63 full-time civilian; 2 military

Key Personnel

Title	Code
Superintendent, Marine Geosciences Division	7400
Associate Superintendent	7401
Administrative Officer	7402
Military Deputy	7405
Head, Marine Physics Branch	7420
Head, Seafloor Sciences Branch	7430
Head, Geospatial Sciences and Technology Branch	7440

Point of contact: Code 7402, (228) 688-4660; DSN 828-4660

Marine Meteorology Division

Code 7500

Research Activity Areas

Atmospheric Dynamics and Prediction

- Global to tactical scale
- Deterministic and probabilistic
- Large eddy simulation
- Boundary layer
- Land surface
- Coastal
- Arctic
- Urban effects
- Massively parallel computing
- Coupled ocean/atmosphere
- Tropical cyclones
- Aerosols
- Topographically forced flow
- Predictability
- Ensembles design
- Advanced numerical methods

Data Assimilation

- Hybrid techniques
- 3D and 4D variational analysis
- Ensemble Transform Kalman Filter (ETKF)
- Quality control and bias correction
- Tropical cyclone initialization
- Remotely sensed data assimilation
- Adjoint applications
- Direct radiance assimilation
- Radar data assimilation
- Targeted observations
- Data selection techniques
- Aerosol assimilation
- UAV data assimilation

Tactical Environmental Support

- Rapid environmental assessment
- Through-the-sensor measurements
- Atmospheric impact on weapons systems
- Chem-bio transport and dispersion
- Data fusion
- Nowcasting
- Visualization
- Expert systems
- Aviation risk assessment

Atmospheric Physics

- Air-sea interaction
- Cloud and aerosol microphysics
- Radiative transfer
- Aerosol characterization
- Tropical cyclone structure

Satellite Data/Imagery

- Automated classification of cloud properties
- Sensor calibration/validation
- Satellite imagery analysis and enhancement
- Multisensor data fusion
- Tropical cyclone characterization
- Dust/aerosols
- Rain rate and snow cover
- Nighttime environmental analysis
- JPSS preparation
- Tactical meteorology

Decision Aids

- Refractivity/ducting
- Ceiling/visibility
- Fog/turbulence/icing
- Atmospheric acoustics
- EM/EO propagation effects
- Tropical cyclones/consensus forecasts
- Nuclear/chemical/biological transport and dispersion
- Port studies
- Typhoon havens
- Forecaster handbooks
- Quantification of uncertainty
- Counter-piracy guidance
- Tropical cyclone sortie guidance
- Forecast difficulty guidance
- Ship wind and wave limits
- Optimal ship routing – fuel savings

A 3D depiction of forecast sensitivity based on a COAMPS model forecast of Hurricane Katrina, obtained using the model's adjoint and tangent linear model

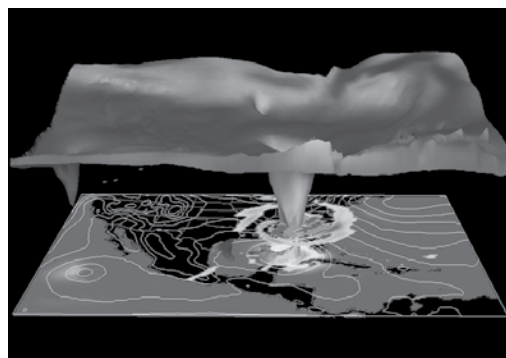

system. The sea-level pressure (white contours) and 10 m wind speed are shown at the surface. The sensitivity of the energy in a box surrounding Katrina to the previous 24-h model vorticity at 2.5 km is shown elevated above the surface. The 3D surface corresponding to the equivalent potential temperature of 340 K, shaded by wind speed, is also displayed.

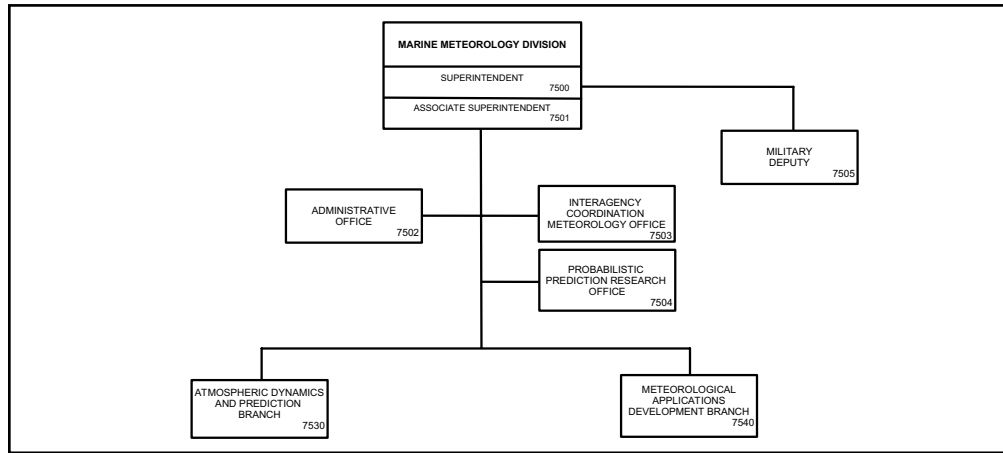

Basic Responsibilities

The Marine Meteorology Division conducts a basic and applied research and development program designed to improve scientific understanding of atmospheric processes that impact Fleet operations and to develop automated systems that analyze, simulate, predict, and interpret the structure and behavior of these processes and their effect on naval weapons systems. Basic and applied research includes work in air-sea interaction, aerosol and cloud physics, atmospheric turbulence, orographically forced flow, atmospheric predictability, scale interactions observation impact, advanced data assimilation, ensemble prediction, tropical dynamics, and numerical methods. Research and development ranges from development of atmospheric analysis/forecast systems and satellite data products to the development of tactical decision aids for operations support. Interdisciplinary research supports the development of coupled analysis/forecast systems, including components for ocean, wave, land surface, aerosol, chemistry, and middle atmosphere prediction. NRL-Monterey (NRL-MRY) is co-located with the Fleet Numerical Meteorology and Oceanography Center (FNMOC) and has developed and transitioned to FNMOC the data assimilation, global and meso-scale weather forecast models, aerosol prediction systems, and satellite applications products that form the backbone of the Navy's worldwide environmental forecasting capability. Specialties of the Division include numerical weather prediction, data assimilation, tropical cyclones, marine boundary layer processes, aerosols, rapid environmental assessment, environmental decision aids, and satellite data analysis, interpretation, and application.

Personnel: 77 full-time civilian; 1 military

Key Personnel

Title	Code
Superintendent, Marine Meteorology Division	7500
Associate Superintendent	7501
Administrative Officer	7502
Head, Interagency Coordination Meteorology Office	7503
Lead Scientist, Probabilistic Prediction Research Office	7504
Military Deputy	7505
Head, Atmospheric Dynamics and Prediction Branch	7530
Head, Meteorological Applications Development Branch	7540

Point of contact: Code 7500, (831) 656-4721; DSN 878-4721

Space Science Division

Code 7600 Research Activity Areas



Geospace Science and Technology

Research to observe, understand, model, and forecast the Earth's operational environment that extends from the lower atmosphere to the magnetopause, in which region both terrestrial and solar effects influence the space environment.

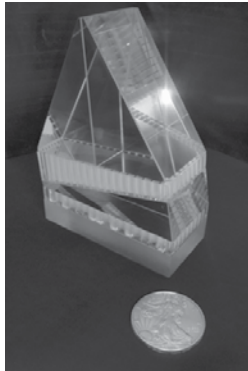

First monolithic Doppler Asymmetric Spatial Heterodyne Spectroscopy (DASH) interferometer. DASH is an innovative, advanced optical technique that can be used to measure winds in the middle and upper atmosphere of Earth and on other planets.

Solar and Heliospheric Physics

Research to develop a fundamental physical understanding of highly variable transient and long-term solar activity; the radiative, plasma, and particulate emissions associated with the activity; and the responses of the heliosphere and the terrestrial magnetosphere to the activity. Relevant empirical data is collected by conceiving, developing, and operating state-of-the-art imaging, spectrometric, and in situ space flight sensors on national and international space missions. Physics-based models are hypothesized, tested with the collected empirical data and computer simulation, and developed.

High Energy Space Environment

Research of energetic particle, γ -ray, and X-ray / ultraviolet environments in space and for other applications of interest to the DoD, homeland security, and national programs, such as detection and surveillance of nuclear materials in terrestrial and space applications.

GLAST launched at 12:05 p.m. EDT on 11 June 2008 from Cape Canaveral Air Force Station on a Delta II 7920-10 rocket. After on-orbit checkout and commissioning, the observatory was renamed the Fermi Gamma-ray Space Telescope in honor of Enrico Fermi.



SECCHI: The Sun-Earth Connection and Heliospheric Investigation instrument suite, shown during testing at NRL, is returning spectacular stereo imagery of the region between the Sun and the Earth.

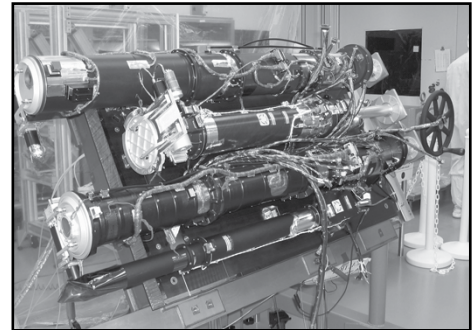

Solar image taken with the Extreme Ultraviolet Imaging Telescope (EIT) on the Solar and Heliospheric Observatory (SOHO) spacecraft. The bright areas are active regions above sunspots, and the dark areas are coronal holes where the open magnetic structure allows the fast solar wind to flow freely out into space.

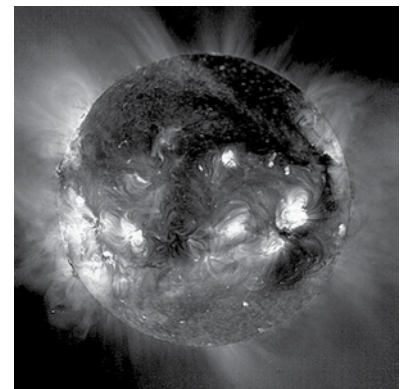

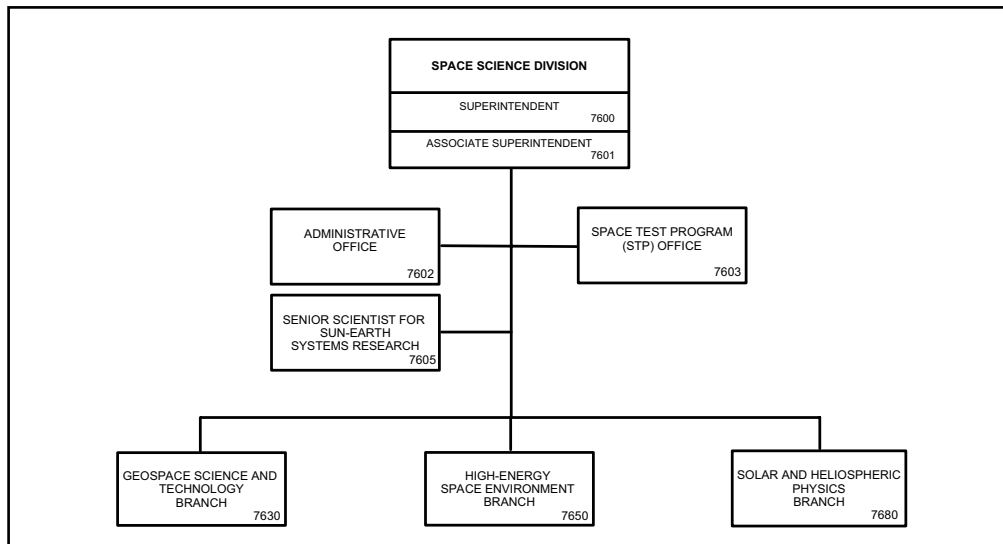

Basic Responsibilities

The Space Science Division conducts a broad-spectrum RDT&E program in solar-terrestrial physics, astrophysics, upper / middle atmospheric science, and astronomy. Instruments to be flown on satellites, sounding rockets and balloons, and ground-based facilities and mathematical models are conceived and developed. Researchers apply these and other capabilities to the study of the atmospheres of the Sun and Earth, including solar activity and its effects on the Earth's ionosphere, upper atmosphere, and middle atmosphere; laboratory astrophysics; and the unique physics and properties of celestial sources. The science is important to orbital tracking, radio communications, and navigation that affect the operation of ships and aircraft, utilization of the near-space and space environment of the Earth, and the fundamental understanding of natural radiation and geophysical phenomena.

Personnel: 81 full-time civilian; 1 military

Key Personnel

Title	Code
Superintendent, Space Science Division	7600
Associate Superintendent	7601
Administrative Officer	7602
Space Test Program Officer, Kirtland AFB, NM	7603
Senior Scientist for Sun-Earth Systems Research	7605
Head, Geospace Science and Technology Branch	7630
Head, High-Energy Space Environment Branch	7650
Head, Solar and Heliospheric Physics Branch	7680

Point of contact: Code 7602, (202) 767-3248

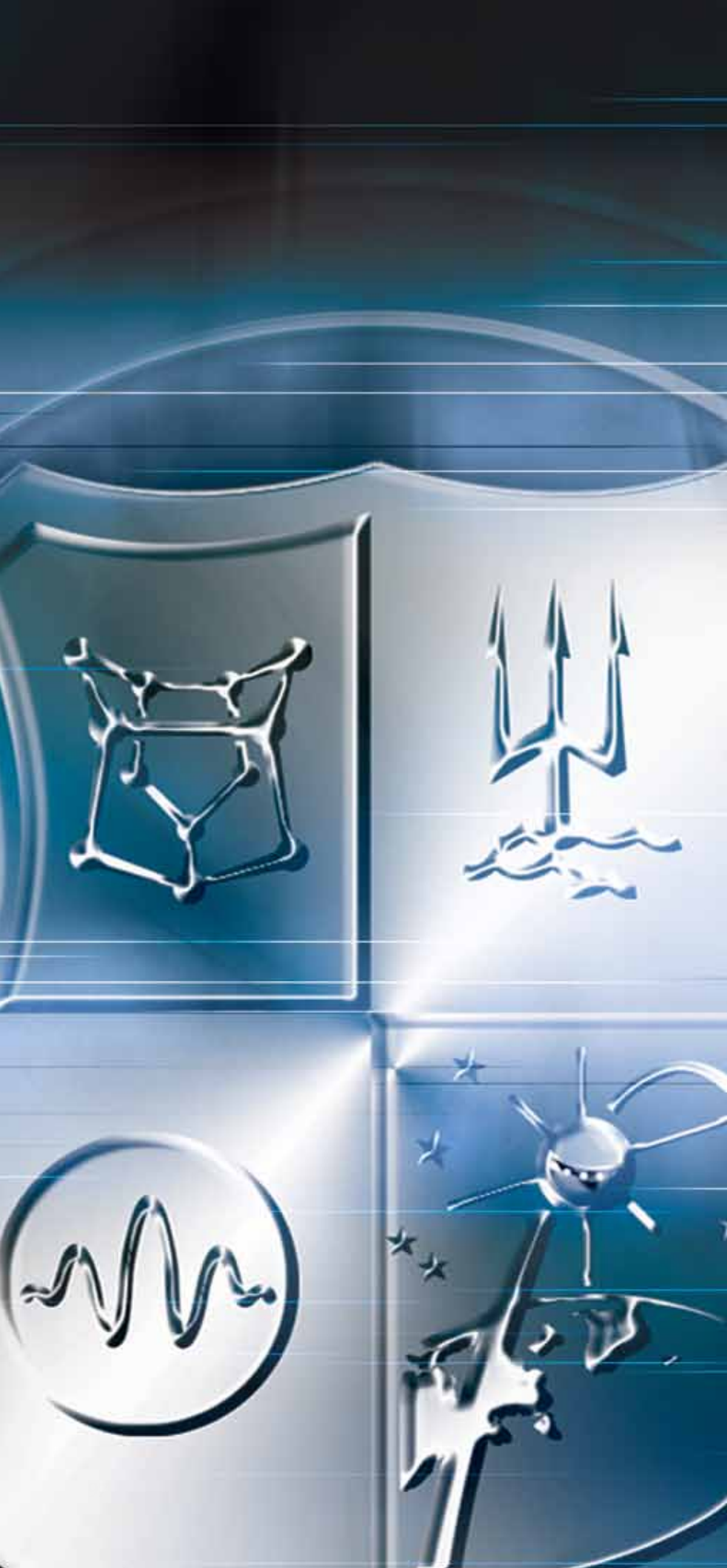

**Naval Center
for Space
Technology**



NAVAL CENTER FOR SPACE TECHNOLOGY

Code 8000

In its role to preserve and enhance a strong space technology base and provide expert assistance in the development and acquisition of space systems that support naval missions, the Naval Center for Space Technology performs basic and applied research through advanced development in all areas of interest to the Navy space program. The Center develops spacecraft, systems using these spacecraft, and ground command and control stations. Principal functions of the Center include understanding and clarifying requirements, recognizing and prosecuting promising research and development, analyzing and testing systems to quantify their capabilities, developing operational concepts that exploit new technical capabilities, per-

forming system engineering to allocate design requirements to subsystems, and performing engineering development and initial operation to test and evaluate selected spacecraft subsystems and systems. The Center is a focal point and integrator for those divisions at NRL whose technologies are used in space systems. The Center also provides systems engineering and technical direction assistance to system acquisition managers of major space systems. In this role, technology transfer is a major goal and motivates a continuous search for new technologies and capabilities and the development of prototypes that demonstrate the integration of such technologies.

Director of Naval Center for Space Technology



Mr. P.G. Wilhelm was born in New York City. He attended Purdue University, where he received a B.S.E.E. degree in 1957. By 1961, he had completed all the course work for an M.S.E. degree from George Washington University.

From 1957 to 1959, Mr. Wilhelm served as an electrical engineer with Stewart Warner Electronics where he was assigned to a project to redesign the UPM-70, a Navy radar test set. In March 1959, he joined the Naval Research Laboratory as an electrical scientist in the Electronics Division. In December 1959, he joined the Satellite Techniques Branch. In 1961, he became Head of the Satellite Instrument Section; in 1965, he became Head of the Satellite Techniques Branch; and in 1974, Head of

the Spacecraft Technology Center. In these positions, he performed satellite system design, equipment development, environmental testing, launch operations, and orbital data handling. In 1981, he was named Superintendent of the Space Systems and Technology Division, the Navy's principal organization, or lead laboratory, for space. He is credited with contributions in the design, development, and operation of more than 100 scientific and Fleet-support satellites. He has been awarded five patents. In October 1986, he was appointed Director of the newly established Naval Center for Space Technology. The Center's mission is to "preserve and enhance a strong space technology base and provide expert assistance in the development and acquisition of space systems which support naval missions."

Mr. Wilhelm has been recognized with numerous awards including the Navy's Meritorious Civilian Service Award, the DoD Distinguished Civilian Service Award, the Presidential Meritorious Executive Award, the Presidential Distinguished Rank Award, the Institute of Electrical and Electronics Engineers Aerospace and Electronic Systems Group Man of the Year Award, the NRL E.O. Hulburt Annual Science and Engineering Award, the Dexter Conrad Award, the Rotary National Stellar Award, the NRL Lifetime Achievement Award, and in May 1999, Mr. Wilhelm received the American Institute of Aeronautics and Astronautics (AIAA) Goddard Astronautics Award. He also has been elected a Fellow of the Washington Academy of Sciences and a Fellow of the American Institute of Aeronautics and Astronautics, and was elected to the National Academy of Engineering. Mr. Wilhelm is also the first recipient of the R.L. Easton Award for excellence in engineering.

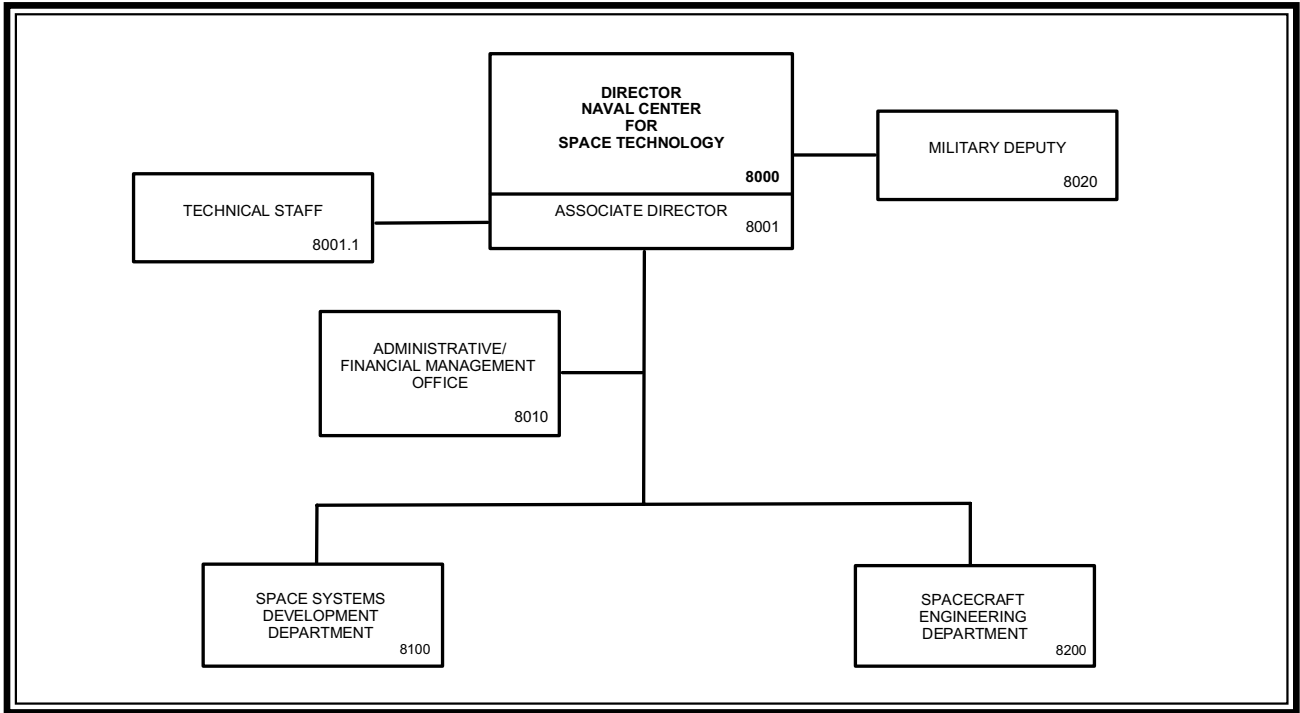

Key Personnel

Title	Code
Director, Naval Center for Space Technology	8000
Associate Director	8001
Technical Staff	8001.1
Head, Administrative/Financial Management Office	8010
Military Deputy	8020
Superintendent, Space Systems Development Department	8100
Superintendent, Spacecraft Engineering Department	8200

Point of contact: Code 8010, (202) 767-6550

Space Systems Development Department

Code 8100 Research Activity Areas

Advanced Space/Airborne/Ground Systems Technologies

- Space systems architectures and requirements
- Advanced payloads and optical communications
- Controllers, processors, signal processing, and VLSI data management systems and equipment
- Embedded algorithms and software
- Satellite laser ranging

Astrodynamics

- Precision orbit estimation
- Onboard autonomous navigation
- Onboard orbit propagation
- GPS space navigation
- Satellite coverage and mission analysis
- Geolocation systems
- Orbit dynamics
- Interplanetary navigation

Command, Control, Communications, Computers, Intelligence, Surveillance, and Reconnaissance

- Communications theory and systems
- Satellite ground station engineering and implementation
- Transportable and fixed ground antenna systems
- High-speed fixed and mobile ground data collection, processing, and dissemination systems
- Tactical communication systems

Space and Airborne Payload Development

- Space and airborne system payload concept definition, design, and implementation including hardware and software
- Detailed electrical/electronic design of electronic and electromechanical payload and systems and components
- Design and verification of real-time embedded multiprocessor software
- Payload antenna systems
- Space and airborne payload fabrication, test, and integration
- Launch and on-orbit payload support

Laser Communications Research

- Ship-to-ship laser communications
- Space-to-ground laser communications
- Satellite laser ranging for precise orbit determination

Space and Airborne Mission Development

- Mission development and requirements definition
- Systems engineering and analysis
- Concepts of operations and mission simulations
- Mission evaluation and performance assessments

Precision Navigation and Time

- Advanced navigation satellite technology
- Precise Time and Time Interval (PTTI) technology
- Atomic time/frequency standards/instrumentation
- Passive and active ranging techniques
- Precision tracking of orbiting objects from space/ground
- National and International standards for timekeeping/Universal Coordinated Time/UTC (NRL)



SEALINK Advanced Analysis (S2A) provides global, persistent, cooperative and non-cooperative maritime vessel tracking awareness and information that is valuable to intelligence analysts, joint warfighters, senior decision makers, and interagency offices within the SCI community.

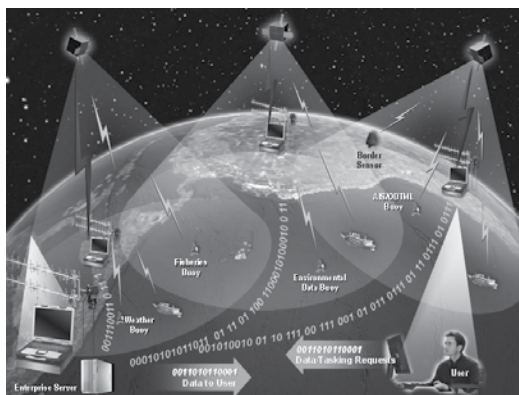

The Global Awareness and Data Extraction International Satellite (GLADIS) is a system of 30 satellites designed to achieve expanded global situational awareness and information sharing.

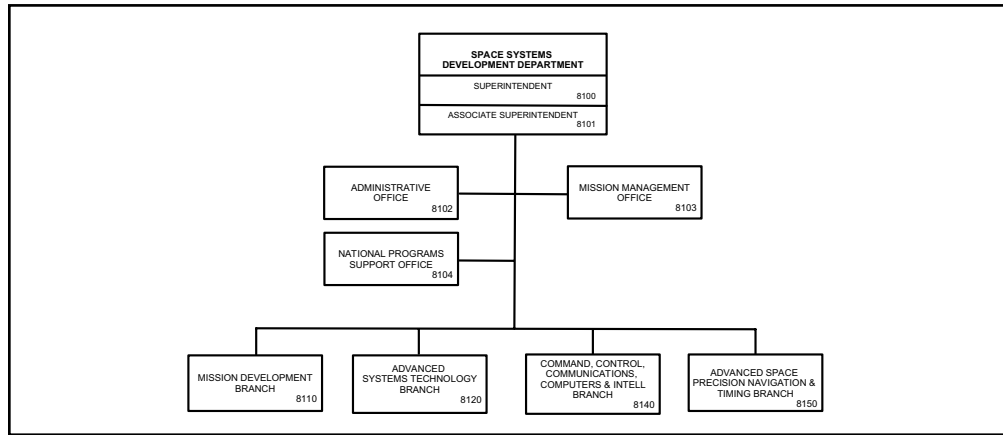

Basic Responsibilities

The Space Systems Development Department (SSDD) is the space and ground support systems research and development organization of the Naval Center for Space Technology. The primary objective of the SSDD is to develop command, control, communications, computers, and intelligence, surveillance, and reconnaissance (C4ISR) hardware and software solutions to space, airborne, and ground applications to respond to Navy, DoD, and national mission requirements with improved performance, capacity, reliability, efficiency, and/or life cycle cost. The Department must derive system requirements from the mission, develop architectures in response to these requirements, and design and develop systems, subsystems, equipment, and implementation technologies to achieve the optimized, integrated operational space, airborne, and ground system. These development responsibilities extend across the entire space/airborne/ground spectrum of hardware, software, and advanced technologies, including digital processing and control, analog systems, power, communications, payload command and telemetry, radio frequency, optical, payload, and electromechanical systems, as well as systems engineering.

Personnel: 126 full-time civilian; 1 part-time civilian; 23 student civilian; 1 intermittent civilian

Key Personnel

Title	Code
Superintendent, Space Systems Development Department	8100
Associate Superintendent	8101
Administrative Officer	8102
Head, Mission Management Office	8103
Head, National Programs Support Office	8104
Head, Mission Development Branch	8110
Head, Advanced Systems Technology Branch	8120
Head, Command, Control, Communications, Computers, and Intelligence Branch	8140
Head, Advanced Space Precision Navigation and Timing Branch	8150

Point of contact: Code 8102, (202) 767-0432

Spacecraft Engineering Department

Code 8200 Research Activity Areas

Design, Test, and Processing

- Design, fabrication, and testing of spacecraft and hardware
- Preliminary and detailed design, fabrication, testing, and integration onto launch vehicle
- Systems engineering for new spacecraft proposals
- Start-to-finish responsibility for NCST spacecraft mechanical systems

Space Mechanical Systems Development

- Research and development in spacecraft technology
- Conceptual design trade studies
- Integrated engineering design and analysis
- Structural and thermal design and analysis
- Development and transition of prototype hardware
- Development and integration of experimental payloads
- Mission integration and development

Control Systems

- Attitude determination and control systems
- Precision pointing
- Optical line-of-sight stabilization
- Propulsion systems
- Precision cleaning and component testing
- Propellant and pressurization systems
- Hydraulic and pneumatics control
- Test systems and services
- Analytical design and mission planning
- Navigation, tracking, and orbit dynamics
- Expert systems
- Flight operations support
- Computer simulation
- Computer animation
- Robotics systems engineering
- Proximity operations
- Autonomous servicing
- Autonomous inspection
- End effector design
- Compliance control
- Trajectory planning
- Machine vision
- Fault detection, isolation, and recovery

Space Electronic Systems Development

- Space system concept definition, design, and implementation including hardware and software
- Detailed electrical/electronic design of electronic and electromechanical systems and components
- Implementation of real-time flight software and embedded command, control, and telemetry software
- Design and verification of real-time embedded multi-processor software
- Spacecraft antenna systems
- Space systems fabrication, test, and integration
- Launch and on-orbit support
- Space test systems and electronic launch support equipment
- Space TT&C and control systems
- Space communication systems

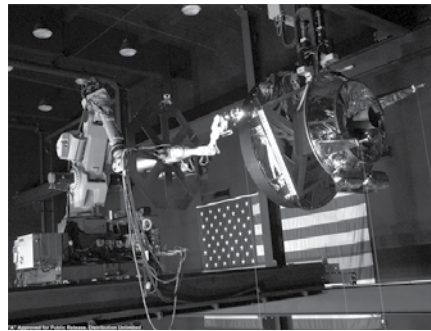

The Space Robotics Laboratory employs two six-degree-of-freedom robotic manipulators to perform realistic orbital and attitude motion simulations for proximity operations of spacecraft. This facility enables hardware-in-the-loop testing of machine vision systems,

capture mechanisms and autonomous guidance, navigation, and control algorithms. The resulting technologies will benefit future DoD space missions involving autonomous rendezvous and capture.

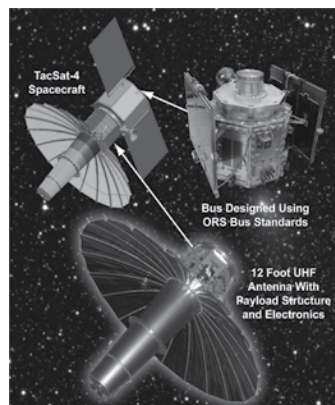

TacSat-4 is a Navy-led joint mission to provide operationally relevant capabilities and enable Operationally Responsive Space (ORS). TacSat-4 provides 10 ultra high frequency channels that can be used for any combination of communications, data exfiltration, or Blue Force tracking. Notably, TacSat-4 provides communications on-the-move with legacy radios and provides a wideband "MOUS-like" channel for early testing. The unique orbit augments geosynchronous communications by allowing near-global, but not continuous, coverage including the high latitudes. TacSat-4 also advances ORS development areas including spacecraft bus standards,

long dwell orbits, dynamic tasking, and net-centric operations. TacSat-4 launched in 2011.

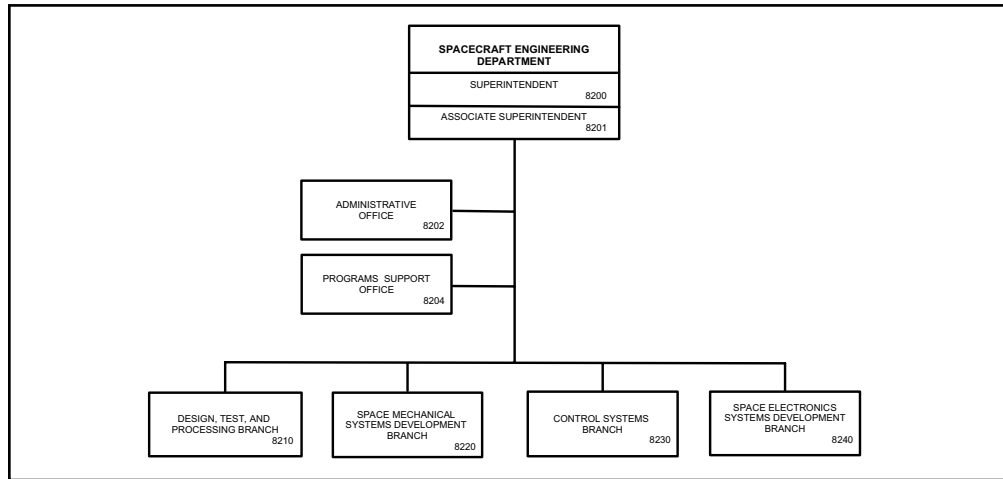

Basic Responsibilities

The Spacecraft Engineering Department (SED) is the focal point for the Navy’s capability to design and build spacecraft. Activities range from concept and feasibility planning to on-orbit IOC for NRL’s space systems.

The SED provides spacecraft bus expertise for the Navy and maintains an active in-house capability to develop satellites; manages Navy space programs through engineering support and technical direction; in concert with the Space Systems Development Department, designs, assembles, and tests spacecraft and space experiments, including all aspects of space, launch, and ground support; analyzes and designs structures, mechanisms, and a variety of control systems, including attitude, propulsion, reaction, and thermal; integrates satellite designs, launch vehicles, and satellite-to-boost stages; functions as a prototype laboratory to ensure that designs can be transferred to industry and incorporated into subsequent satellite hardware builds; and consults with the Navy Program Office on technical issues involving spacecraft architecture, acquisition, and operation.

Personnel: 128 full-time civilian; 2 part-time civilian; 26 student civilian

Key Personnel

Title	Code
Superintendent, Spacecraft Engineering Department	8200
Associate Superintendent	8201
Administrative Officer	8202
Head, Programs Support Office	8204
Head, Design, Test, and Processing Branch	8210
Head, Space Mechanical Systems Development Branch	8220
Head, Control Systems Branch	8230
Head, Space Electronics Systems Development Branch	8240

Point of contact: Code 8202, (202) 767-6412

**Technical
Output,
Fiscal, and
Personnel
Information**

Technical Output

Publications, Presentations, and Patents

The Navy continues to be a pioneer in science and engineering developments and a leader in applying these advancements to military requirements. The primary means of informing the scientific and engineering community of the advances made at NRL is through the Laboratory's technical output—reports, articles in scientific journals, contributions to books, papers presented to scientific societies and topical conferences, patents, and inventions.

The figures for calendar years 2010 and 2011 presented below represent the output of NRL facilities in Washington, DC; Bay St. Louis, Mississippi; and Monterey, California.

In 1986, Congress enacted the Federal Technology Transfer Act in an effort to encourage the commercial use of technology developed in Federal laboratories. The Act allows Government inventors and the laboratories where they work to share the royalties generated by commercial licensing of their inventions. Also, the Act encourages the establishment of Cooperative Research and Development Agreements (CRADAs) between laboratories such as NRL and non-Federal entities such as state and local governments, universities, and business corporations. Such cooperative R&D agreements can include the allocation in advance of patent rights on any inventions made under the joint research effort.

The 1986 Act has given additional impetus to the Laboratory's efforts to patent important inventions arising out of its various research programs.

Calendar Year 2010

Type of Contribution	Unclassified	Classified	Total
Articles in periodicals, chapters in books, and papers in published proceedings	1502	0	1502
Oral Presentations	2181	0	2181
NRL Formal Reports	6	6	12
NRL Memorandum Reports	67	8	75
Books	2	0	2
Patents granted	51	0	51
Statutory Invention Registrations (SIRs)	0	0	0

Calendar Year 2011

Type of Contribution	Unclassified	Classified	Total
Articles in periodicals, chapters in books, and papers in published proceedings	1398	0	1398*
Oral Presentations	2301	0	2301
NRL Formal Reports	6	5	11
NRL Memorandum Reports	51	4	55
Books	1	0	1
Patents granted	87	1	88
Statutory Invention Registrations (SIRs)	0	0	0

*This is a provisional total based on information available to the Ruth H. Hooker Research Library on August 1, 2012. Total includes refereed and non-refereed publications.

FY 2010/2011 Sources of New Funds (Actual)

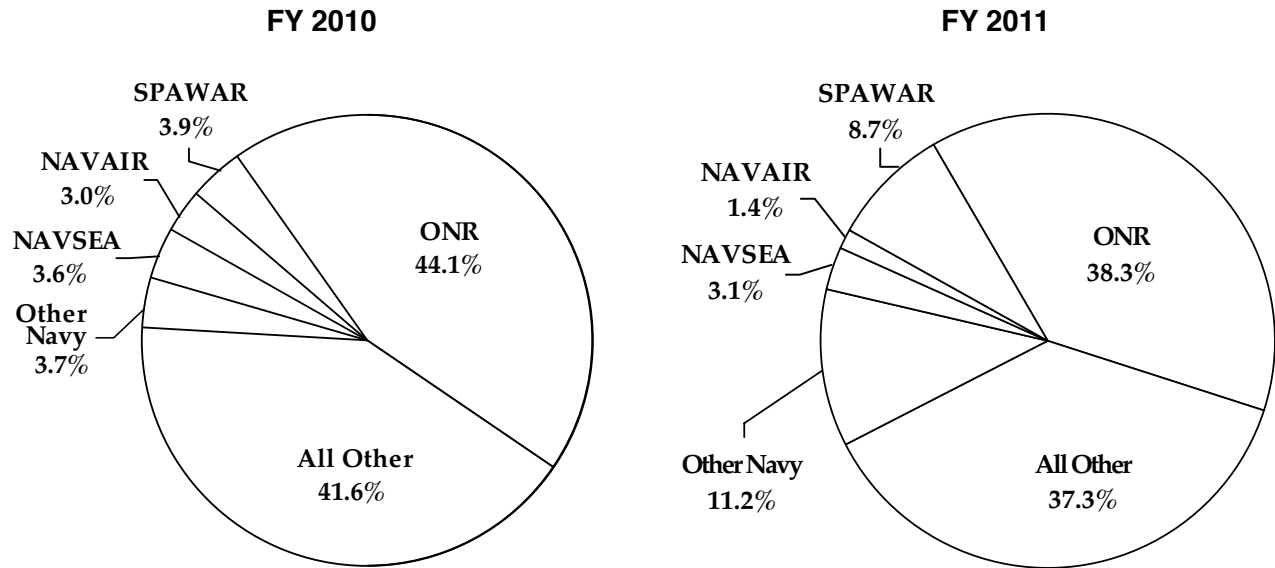

**FY 2010
Source of Funds (%)**

	\$M		Total
	Reimbursable	Direct Cite	
FY 2010			
Office of Naval Research (ONR)	314.0	168.2	482.2
Naval Sea Systems Command (NAVSEA)	19.6	19.7	39.3
Space and Naval Warfare Systems Command (SPAWAR)	34.6	8.1	42.6
Naval Air Systems Command (NAVAIR)	11.5	21.8	33.3
Other Navy	19.3	21.5	40.8
All Other	<u>284.6</u>	<u>170.2</u>	<u>454.8</u>
Total Funds	683.6	409.5	1,093.1

**FY 2011
Source of Funds (%)**

	\$M		Total
	Reimbursable	Direct Cite	
FY 2011			
Office of Naval Research (ONR)	319.6	101.6	421.2
Naval Sea Systems Command (NAVSEA)	22.9	10.9	33.8
Space and Naval Warfare Systems Command (SPAWAR)	40.7	54.7	95.4
Naval Air Systems Command (NAVAIR)	7.8	7.4	15.2
Other Navy	72.3	50.2	122.5
All Other	<u>264.2</u>	<u>145.9</u>	<u>410.1</u>
Total Funds	727.6	370.6	1,098.2

FY 2010/2011 Uses of Funds

FY 2010

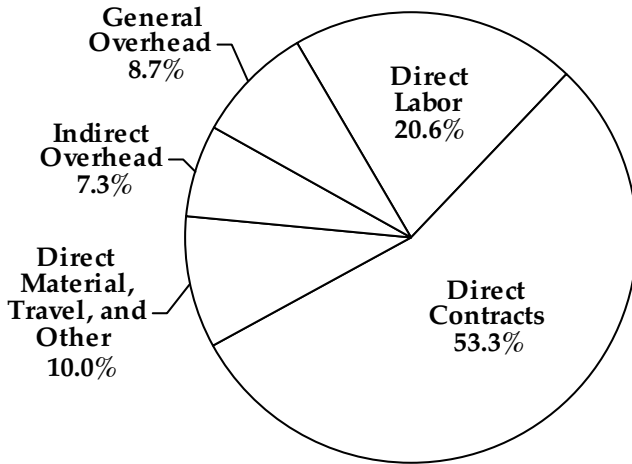

FY 2011

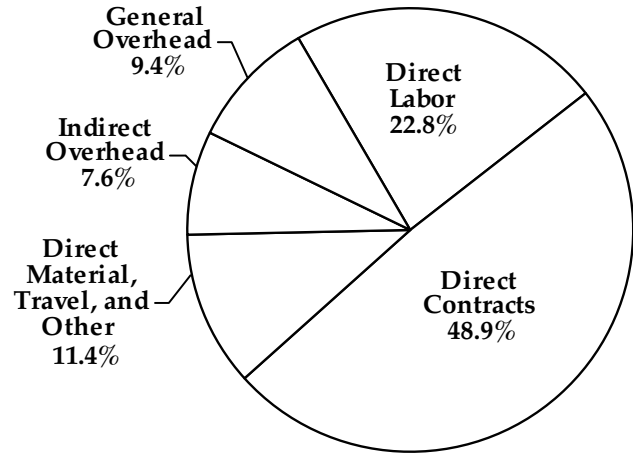

FY 2010

Distribution of Funds (%)

	\$M
Direct Labor	228.9
General Overhead	96.0
Indirect Overhead	81.5
Direct Material, Travel, and Other	111.4
Direct Contracts	<u>591.8</u>
Total Costs*	1,109.6

FY 2011

Distribution of Funds (%)

	\$M
Direct Labor	241.5
General Overhead	99.2
Indirect Overhead	80.0
Direct Material, Travel, and Other	120.3
Direct Contracts	<u>517.3</u>
Total Costs*	1,058.3

*Costs based on CFO statements; direct contracts include costs for reimbursable-funded contracts and obligations for direct cite-funded contracts.

FY 2010 Total New Funds by Category

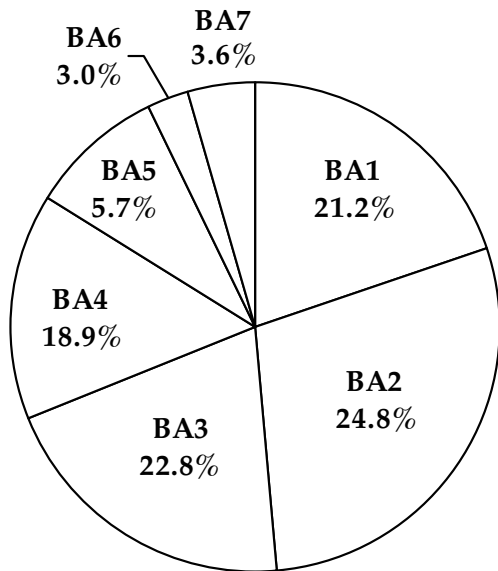

Distribution of RDT&E, Navy (%)
(\$612.4)

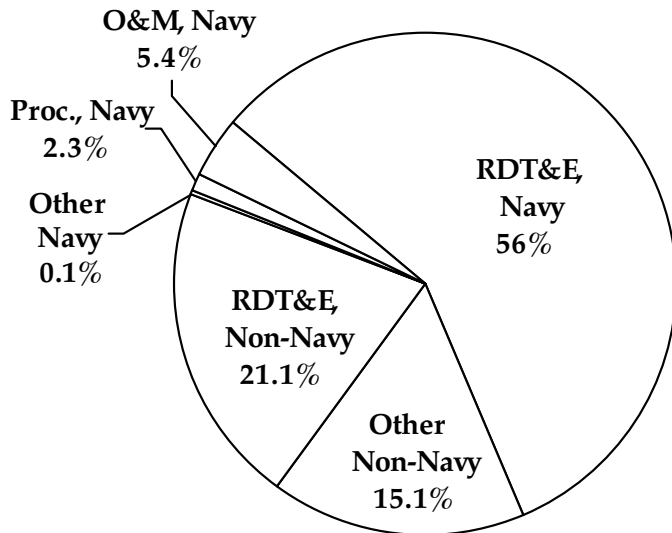

Distribution of Total (%)
(\$1,093.1)

FY 2010

Category	\$M		Total
	Navy	Non-Navy	
BA1 Basic Research	130.1	9.4	139.5
BA2 Applied Research	151.6	31.6	183.2
BA3 Advanced Technology Development	139.8	93.3	233.1
BA4 Advanced Component Development Prototypes	115.9	60.8	176.7
BA5 System Development and Demonstration	34.7	4.7	39.4
BA6 RDT&E Management Support	18.2	8.8	27
BA7 Operational System Development	<u>22.1</u>	<u>22.4</u>	<u>44.5</u>
Subtotal RDT&E	612.4	231	843.4
Operations and Maintenance	58.7	43.8	102.5
Procurement	24.7	39.5	64.2
Other	<u>1.6</u>	<u>81.4</u>	<u>83</u>
Total New Funds	697.4	395.7	1,093.1

FY 2011 Total New Funds by Category

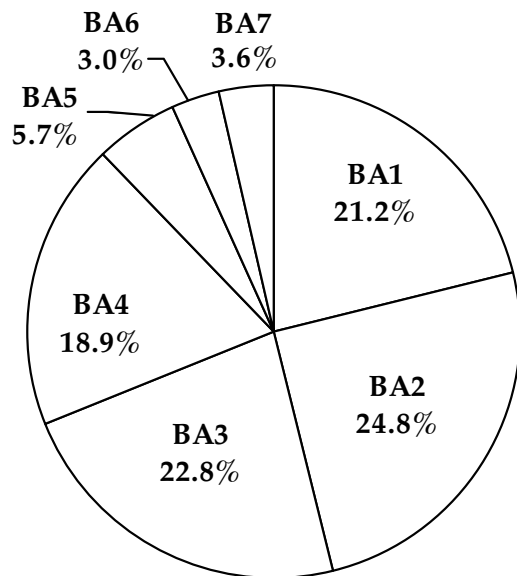

Distribution of RDT&E, Navy (%)
(\$587.1)

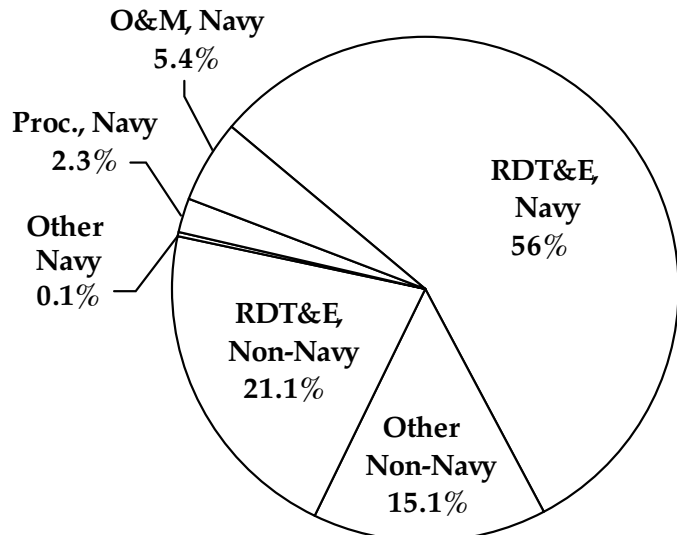

Distribution of Total (%)
(\$1098.2)

FY 2011

Category	\$M		Total
	Navy	Non-Navy	
BA1 Basic Research	126.7	7.4	134.1
BA2 Applied Research	161.2	33.5	194.7
BA3 Advanced Technology Development	117.3	90.4	207.7
BA4 Advanced Component Development Prototypes	112.1	67.6	179.7
BA5 System Development and Demonstration	31.6	15.5	47.1
BA6 RDT&E Management Support	17.2	7.2	24.4
BA7 Operational System Development	21	24.9	45.9
Subtotal RDT&E	587.1	246.5	833.6
Operations and Maintenance	65.7	58.5	102.5
Procurement	21.2	38.8	64.2
Other	1.7	78.7	83
Total New Funds	675.7	422.5	1,098.2

Personnel Information*

Civilian On-Board

Full-Time, Permanent (FTP)	
Graded	2,328
Ungraded	<u>92</u>
Total	2,420
Temporary, Part-Time, Intermittent (TPTI)	
TPTI	<u>302</u>
Total Civilian	2,722

FTP Breakdown

Scientific/Engineering Professional	1,572
Scientific/Engineering Technical	92
Administrative Specialist/Professional	376
Administrative Support	251
Senior Executive Service	21
Scientific or Professional	16
General Schedule	<u>0</u>
Total	2,328

Military On-Board

Officers	33
Enlisted	<u>52</u>
Total Military On-Board	85
(Military Allowance)	110

Annual Civilian Turnover Rate (%) (permanent employees only)

	2003	2004	2005	2006	2007	2008	2009	2010	2011
Research divisions	6.0	6.8	7.2	9.5	8.5	6.9	4.7	5	5.3
Nonresearch areas	8.2	8.2	8.5	11.0	13.7	13.3	7.4	11	13.5
Entire Laboratory	6.4	6.5	7.4	9.7	9.6	8.2	5.3	6.2	6.9

Highest Academic Degrees Held by Civilian Permanent Employees

Bachelors	573
Masters	368
Doctorates	839

*All data is as of 31 July 2012 unless otherwise noted.

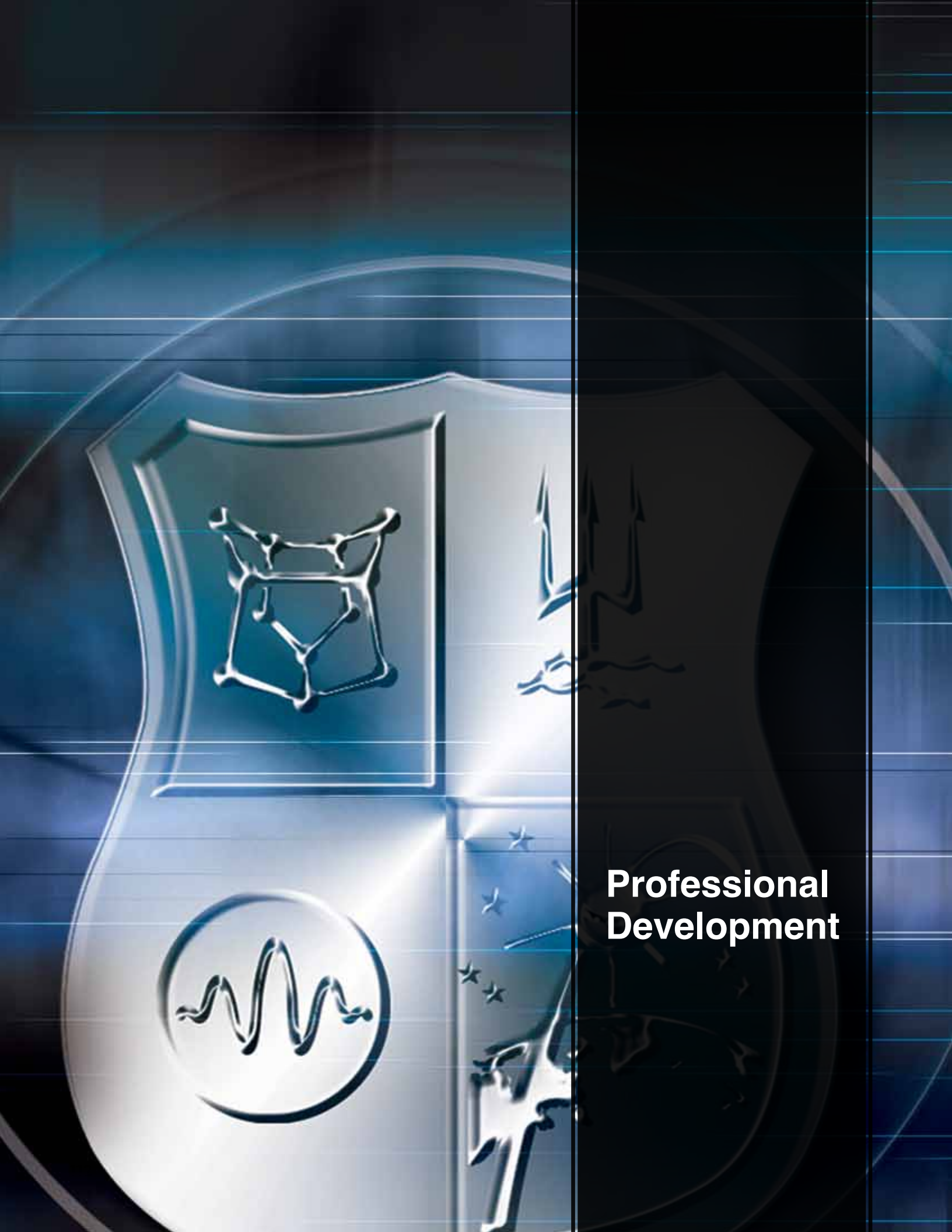

**Professional
Development**

Professional Development

Programs for NRL Employees

The Human Resources Office supports and provides traditional and alternative methods of training for employees. NRL employees are encouraged to develop their skills and enhance their job performance so they can meet the future needs of NRL and achieve their own goals for growth.

One common study procedure is for employees to work full time at the Laboratory while taking job-related courses at universities and schools local to their job site. The training ranges from a single course to undergraduate, graduate, and postgraduate course work. Tuition for training is paid by NRL. The formal programs offered by NRL are described here.

Graduate Programs

The **Advanced Graduate Research Program** (formerly the Sabbatical Study Program, which began in 1964) enables selected professional employees to devote full time to research or pursue work in their own or a related field for up to one year at an institution or research facility of their choice without the loss of regular salary, leave, or fringe benefits. NRL pays all travel and moving expenses for the employee. Criteria for eligibility include professional stature consistent with the applicant's opportunities and experience, a satisfactory program of study, and acceptance by the facility selected by the applicant. The program is open to employees who have completed six years of Federal service, four of which have been at NRL.

The **Edison Memorial Graduate Training Program** enables employees to pursue graduate studies in their fields at local universities. Participants in this program may work 24 hours each workweek and pursue their studies during the other 16 hours. The criteria for eligibility include a minimum of one year of service at NRL, a bachelor's or master's degree in an appropriate field, and professional standing in keeping with the candidate's opportunities and experience.

To be eligible for the **Select Graduate Training Program**, employees must have a bachelor's degree in an appropriate field and must have demonstrated ability and aptitude for advanced training. Students accepted into this program receive one-half of their salary and benefits

and NRL pays for tuition and travel expenses.

The **Naval Postgraduate School (NPS)**, located in Monterey, California, provides graduate programs to enhance the technical preparation of Naval officers and civilian employees who serve the Navy in the fields of science, engineering, operations analysis, and management. NRL employees desiring to pursue graduate studies at NPS may apply; thesis work is accomplished at NRL. Participants continue to receive full pay and benefits during the period of study. NRL also pays for tuition and travel expenses.

In addition to NRL and university offerings, application may be made to a number of noteworthy programs and fellowships. Examples of such opportunities are the **Capitol Hill Workshops**, the **Legislative Fellowship (LEGIS) program**, the **Federal Executive Institute (FEI)**, and the **Executive Leadership Program for Mid-Level Employees**. These and other programs are announced from time to time, as schedules are published.

Continuing Education

Undergraduate and graduate courses offered at local colleges and universities may be subsidized by NRL for employees interested in improving their skills and keeping abreast of current developments in their fields.

NRL offers **short courses** to all employees in a number of fields of interest including administrative subjects and supervisory and management techniques. Laboratory employees may also attend these courses at nongovernment facilities.

For further information on any of the above Graduate and Continuing Education programs, contact the Workforce Development and Management Branch (Code 1840) at (202) 404-8314 or via email at Training@hro.nrl.navy.mil.

The **Scientist-to-Sea Program (STSP)** provides opportunities for Navy R&D laboratory/center personnel to go to sea to gain first-hand insight into operational factors affecting system design, performance, and operations on a variety of ships. NRL is a participant of this Office of Naval Research (ONR) program. Contact (202) 767-7627.

Professional Development

NRL has several programs, professional society chapters, and informal clubs that enhance the professional growth of employees. Some of these are listed below.

The **Counseling & Referral Service (C/RS)** helps employees improve job performance through counseling designed to resolve problems that may adversely affect job performance. Such problems may include family and/or work-related stress, relationship difficulties, or behavioral, emotional, or substance abuse problems. C/RS provides confidential assessment, short-term counseling, training workshops, and referral to additional resources in the community. Contact (202) 767-6857.

The **NRL Women in Science and Engineering (WISE) Network** was formed in 1997 through the merger of the NRL chapter of WISE and the Women in Science and Technology Network. Luncheon meetings and seminars are held to discuss scientific research areas, career opportunities, and career-building strategies. The group also sponsors projects to promote the professional success of the NRL S&T community and improve the NRL working environment. Membership is open to all S&T professionals. Contact (202) 404-4389.

Sigma Xi, The Scientific Research Society, encourages and acknowledges original investigation in pure and applied science. It is an honor society for research scientists. Individuals who have demonstrated the ability to perform original research are elected to membership in local chapters. The NRL Edison Chapter, comprising approximately 200 members, recognizes original research by presenting annual awards in pure and applied science to two outstanding NRL staff members per year. In addition, an award seeking to reward rising stars in the lab is presented annually through the Young Investigator Award. The chapter also sponsors several lectures per year at NRL on a wide range of topics of general interest to the scientific and DoD community. These lectures are delivered by scientists from all over the world. The highlight of the Sigma Xi Lecture Series is the Edison Memorial Lecture, which traditionally is given by an internationally distinguished scientist. Contact (202) 767-2007.

The **NRL Mentor Program** was established to provide an innovative approach to professional and career training and an environment for personal and professional growth. It is open to permanent NRL employees in all job series and at all sites. Mentorees are matched with successful, experienced colleagues having more technical and/or managerial experience who can provide them with the knowledge and skills needed to maximize their contribution to the success of their immediate organization, to NRL, to the Navy, and to their chosen career fields. The ultimate goal of the program is to increase job productivity, creativity, and satisfaction through better com-

munication, understanding, and training. NRL Instruction 12400.1B provides policy and procedures for the program. For more information please contact mentor@hro.nrl.navy.mil or (202) 767-6736.

Employees interested in developing effective self-expression, listening, thinking, and leadership potential are invited to join the Forum Club, a chapter of **Toastmasters International**. Members of this club possess diverse career backgrounds and talents and learn to communicate not by rules but by practice in an atmosphere of understanding and helpful fellowship. NRL's Commanding Officer and Director of Research endorse Toastmasters. Contact (202) 404-4670.

Equal Employment Opportunity (EEO) Programs

Equal employment opportunity (EEO) is a fundamental NRL policy for all employees regardless of race, color, national origin, sex, religion, age, sexual orientation, or disability. The NRL EEO Office is a service organization whose major functions include counseling employees in an effort to resolve employee/management conflicts, processing formal discrimination complaints, providing EEO training, and managing NRL's affirmative employment recruitment program. The NRL EEO Office is also responsible for sponsoring special-emphasis programs to promote awareness and increase sensitivity and appreciation of the issues or the history relating to females, individuals with disabilities, and minorities. Contact the NRL Deputy EEO Officer at (202) 767-2486 for additional information on any of their programs or services.

Other Activities

The award-winning **Community Outreach Program** directed by the NRL Public Affairs Office fosters programs that benefit students and other community citizens. Volunteer employees assist with and judge science fairs, give lectures, provide science demonstrations and student tours of NRL, and serve as tutors, mentors, coaches, and classroom resource teachers. The program sponsors student tours of NRL, and an annual holiday party for neighborhood children in December. Through the program, NRL has active partnerships with three District of Columbia public schools. Contact (202) 767-2541.

Other programs that enhance the development of NRL employees include sports and theater groups and the **Amateur Radio Club**. The **NRL Fitness Center** at NRL-DC, managed by Naval Support Activity Washington Morale, Welfare and Recreation (NSAW-MWR), houses a fitness room with treadmills, bikes, ellipticals, step mills, and a full strength circuit; a gymnasium for basketball, volleyball, and other activities; a game room; and full locker rooms. The Fitness Center is free to NRL employ-

ees and contractors. NRL employees are also eligible to participate in all NSAW MWR activities held on Joint Base Anacostia–Bolling and Washington Navy Yard, less than five miles away. The **NRL Showboaters Theatre**, organized in 1974, is “in the dark.” Visit www.nrl.navy.mil/showboaters/Past_Productions.php for pictures from past productions such as *Annie Get Your Gun*, *Gigi*, and *Hello Dolly*. Contact (202) 404-4998 for Play Reader’s meetings at NRL.

Programs for Non-NRL Employees

Several programs have been established for non-NRL professionals. These programs encourage and support the participation of visiting scientists and engineers in research of interest to the Laboratory. Some of the programs may serve as stepping-stones to Federal careers in science and technology. Their objective is to enhance the quality of the Laboratory’s research activities through working associations and interchanges with highly capable scientists and engineers and to provide opportunities for outside scientists and engineers to work in the Navy laboratory environment. Along with enhancing the Laboratory’s research, these programs acquaint participants with Navy capabilities and concerns and may provide a path to full-time employment.

Recent Ph.D., Faculty Member, and College Graduate Programs

The **National Research Council (NRC) Cooperative Research Associateship Program** selects associates who conduct research at NRL in their chosen fields in collaboration with NRL scientists and engineers. Appointments are for one year (renewable for a second and possible third year).

The **NRL/ASEE Postdoctoral Fellowship Program**, administered by the American Society for Engineering Education (ASEE), aims to increase the involvement of highly trained scientists and engineers in disciplines necessary to meet the evolving needs of naval technology. Appointments are for one year (renewable for a second and possible third year).

The **Naval Research Enterprise Intern Program (NREIP)** is a ten-week program involving NROTC colleges/universities and their affiliates. The Office of Naval Research (ONR) offers summer appointments at Navy laboratories to current sophomores, juniors, seniors, and graduate students from participating schools. Application is online at www.asee.org/nreip through the American Society for Engineering Education. Electronic applications are sent for evaluation to the point of contact at the Navy laboratory identified by the applicant. Students are

provided a stipend of \$7,500 (undergraduates) or \$10,000 (graduate students).

The American Society for Engineering Education also administers the **Navy/ASEE Summer Faculty Research and Sabbatical Leave Program** for university faculty members to work for ten weeks (or longer, for those eligible for sabbatical leave) with professional peers in participating Navy laboratories on research of mutual interest.

The **NRL/United States Naval Academy (USNA) Cooperative Program for Scientific Interchange** allows faculty members of the U.S. Naval Academy to participate in NRL research. This collaboration benefits the Academy by providing the opportunity for USNA faculty members to work on research of a more practical or applied nature. In turn, NRL’s research program is strengthened by the available scientific and engineering expertise of the USNA faculty.

The **National Defense Science and Engineering Graduate Fellowship Program** helps U.S. citizens obtain advanced training in disciplines of science and engineering critical to the U.S. Navy. The three-year program awards fellowships to recent outstanding graduates to support their study and research leading to doctoral degrees in specified disciplines such as electrical engineering, computer sciences, material sciences, applied physics, and ocean engineering. Award recipients are encouraged to continue their study and research in a Navy laboratory during the summer.

For further information about the above six programs, contact (202) 404-7450.

Professional Appointments

Faculty Member Appointments use the special skills and abilities of faculty members for short periods to fill positions of a scientific, engineering, professional, or analytical nature at NRL.

Consultants and experts are employed because they are outstanding in their fields of specialization or because they possess ability of a rare nature and could not normally be employed as regular civil servants.

Intergovernmental Personnel Act Appointments temporarily assign personnel from state or local governments or educational institutions to the Federal Government (or vice versa) to improve public services rendered by all levels of government.

College and High School Student Programs

The student programs are tailored to high school, undergraduate, and graduate students to provide employment opportunities and work experience in naval research. These programs are designed to attract appli-

cants for student and full professional employment in fields such as engineering, physics, mathematics, and computer sciences. The student employment programs are designed to help students and educational institutions gain a better understanding of NRL's research, its challenges, and its opportunities. To participate in these programs, the student must be continuously enrolled in school on at least a half-time basis at a qualifying educational institution; and be at least 16 years of age and a U.S. citizen.

The **Student Career Experience Program (SCEP)** employs students in study-related occupations. The program is conducted in accordance with a planned schedule and a working agreement among NRL, the educational institution, and the student. Primary focus is on the pursuit of undergraduate and graduate degrees in engineering, computer science, or the physical sciences. Applications are accepted year-round.

The **Student Temporary Employment Program (STEP)** is a one year temporary employment program that may be renewed. This program enables students to earn a salary while continuing their studies and offers them valuable work experience. They must be continuously enrolled in school on at least a half-time basis at a qualifying educational institution. Applications are accepted year-round.

The **Summer Employment Program (SEP)** employs students for the summer that are enrolled in a qualifying educational institution on at least a half-time basis studying paraprofessional and technician positions in engineering, physical sciences, computer sciences, and mathematics. Applications are due the second Friday in February.

The **Student Volunteer Program** helps students gain valuable experience by allowing them to voluntarily perform educationally related work at NRL. Applications are accepted year-round.

For additional information on these student programs, contact (202) 767-8313.

For high school students, the **DoD Science & Engineering Apprentice Program (SEAP)** offers students grades 9 to 12 the opportunity to serve for eight weeks to participate in research at a Department of Navy laboratory during the summer. Under the direction of a mentor, students gain a better understanding of the challenges and opportunities of research through participation in scientific programs. Criteria for eligibility are based on science and mathematics courses completed and grades achieved; scientific motivation, curiosity, and capacity for sustained hard work; a desire for a technical career; teacher recommendations; and achievement test scores. For more information, please contact the SEAP coordinator at SEAP@hro.nrl.navy.mil or (202) 767-8324/8309/6736.



**General
Information**

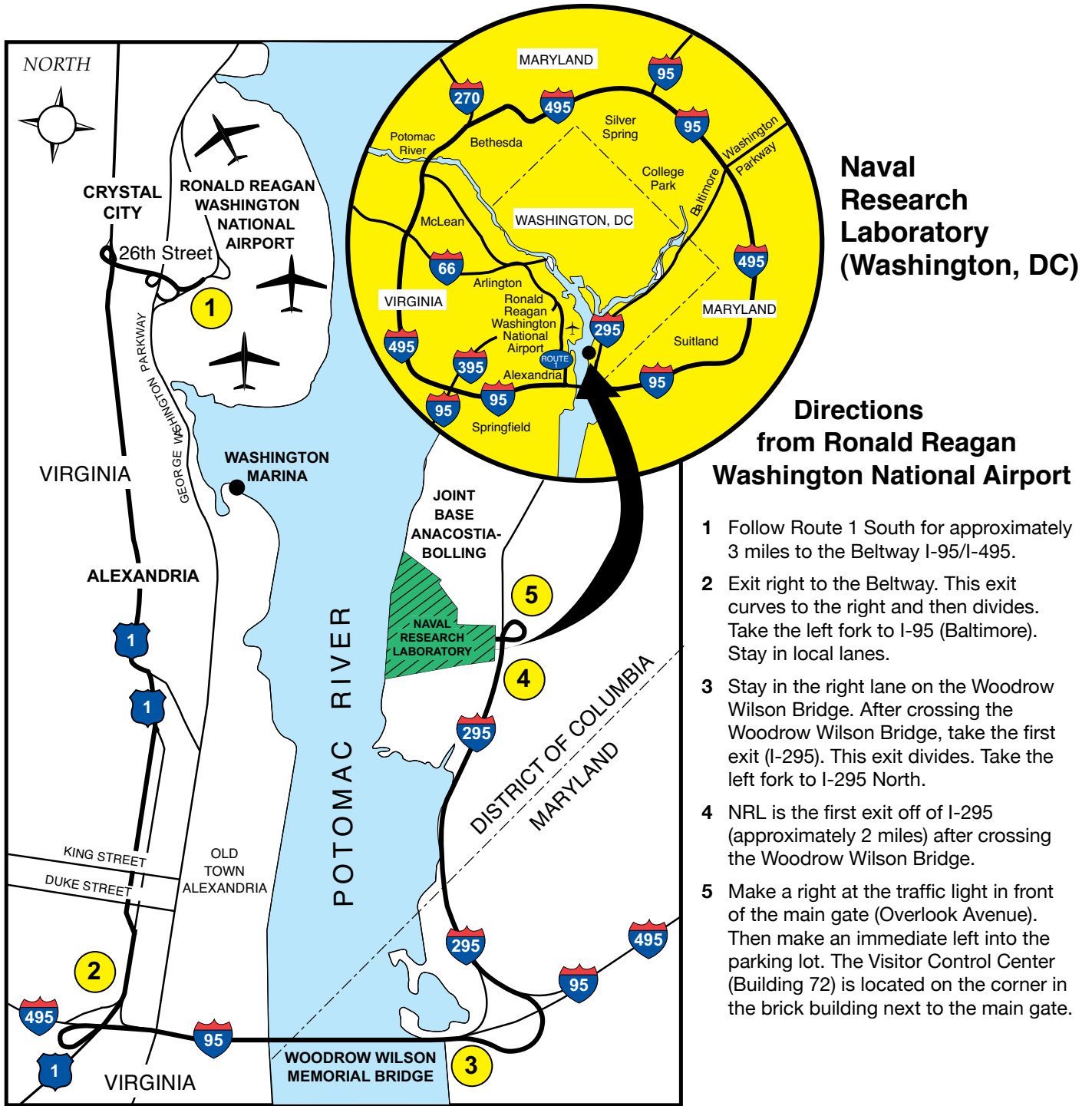

Naval Research Laboratory (Washington, DC)

Directions from Ronald Reagan Washington National Airport

- 1 Follow Route 1 South for approximately 3 miles to the Beltway I-95/I-495.
- 2 Exit right to the Beltway. This exit curves to the right and then divides. Take the left fork to I-95 (Baltimore). Stay in local lanes.
- 3 Stay in the right lane on the Woodrow Wilson Bridge. After crossing the Woodrow Wilson Bridge, take the first exit (I-295). This exit divides. Take the left fork to I-295 North.
- 4 NRL is the first exit off of I-295 (approximately 2 miles) after crossing the Woodrow Wilson Bridge.
- 5 Make a right at the traffic light in front of the main gate (Overlook Avenue). Then make an immediate left into the parking lot. The Visitor Control Center (Building 72) is located on the corner in the brick building next to the main gate.

Naval Research Laboratory
 4555 Overlook Avenue, SW
 Washington, DC 20375-5320
 (202) 767-3200 – DSN 297-3200

Location of Buildings at NRL Washington

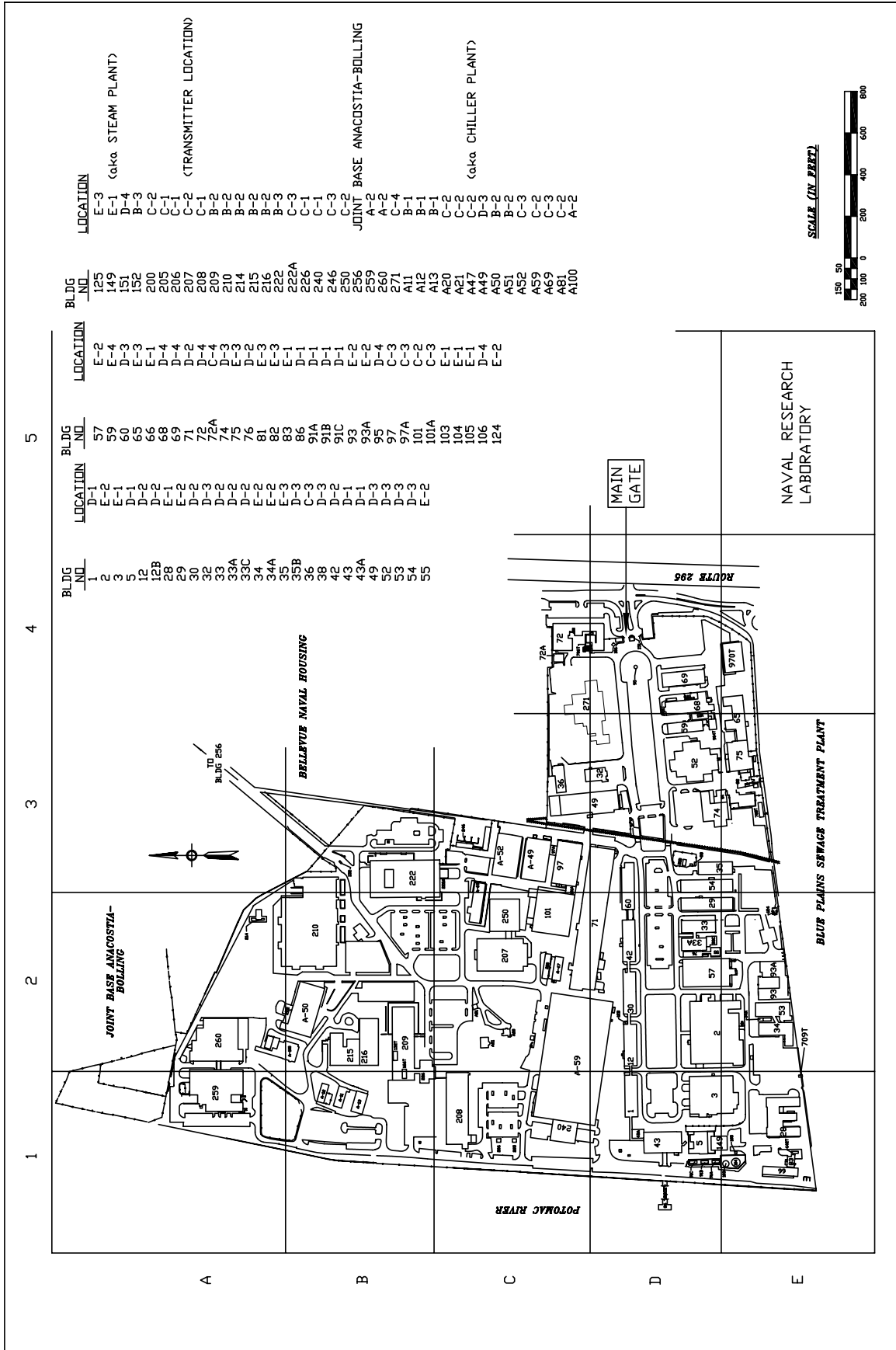

Location of Field Sites in the NRL Washington Area

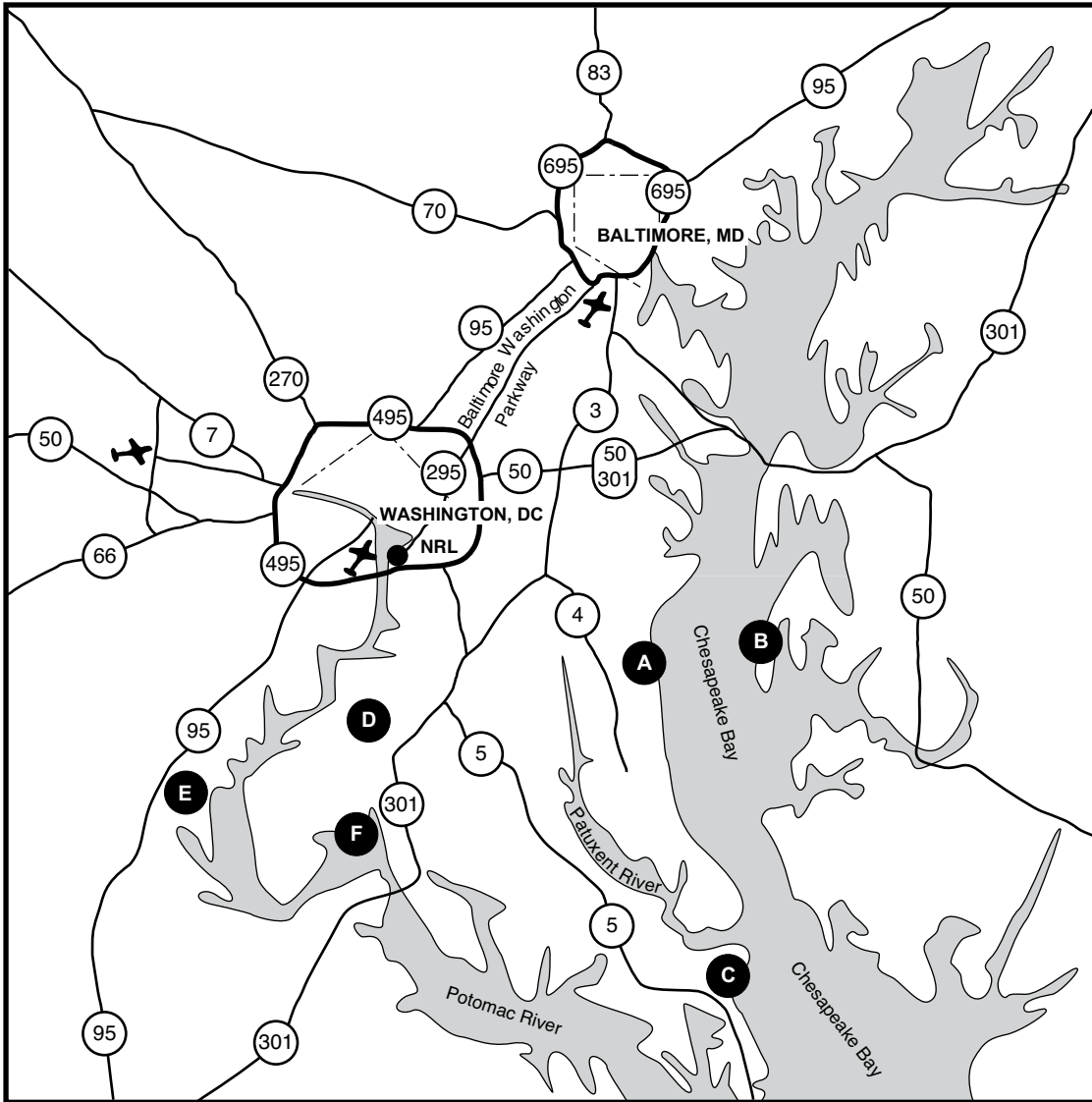

<u>Location</u>	<u>Approximate Mileage from NRL Washington</u>	<u>Cognizant Code</u>
A - Chesapeake Bay Section, Chesapeake Beach, MD	40	3522
B - Tilghman Island, MD	110	3522
C - Patuxent River (MD) Naval Air Station	64	1600
D - Pomonkey, MD	20	8124
E - Midway Research Center, Quantico, VA	38	8140
F - Blossom Point, MD	40	8140

Chesapeake Bay Section (Chesapeake Beach, Maryland)

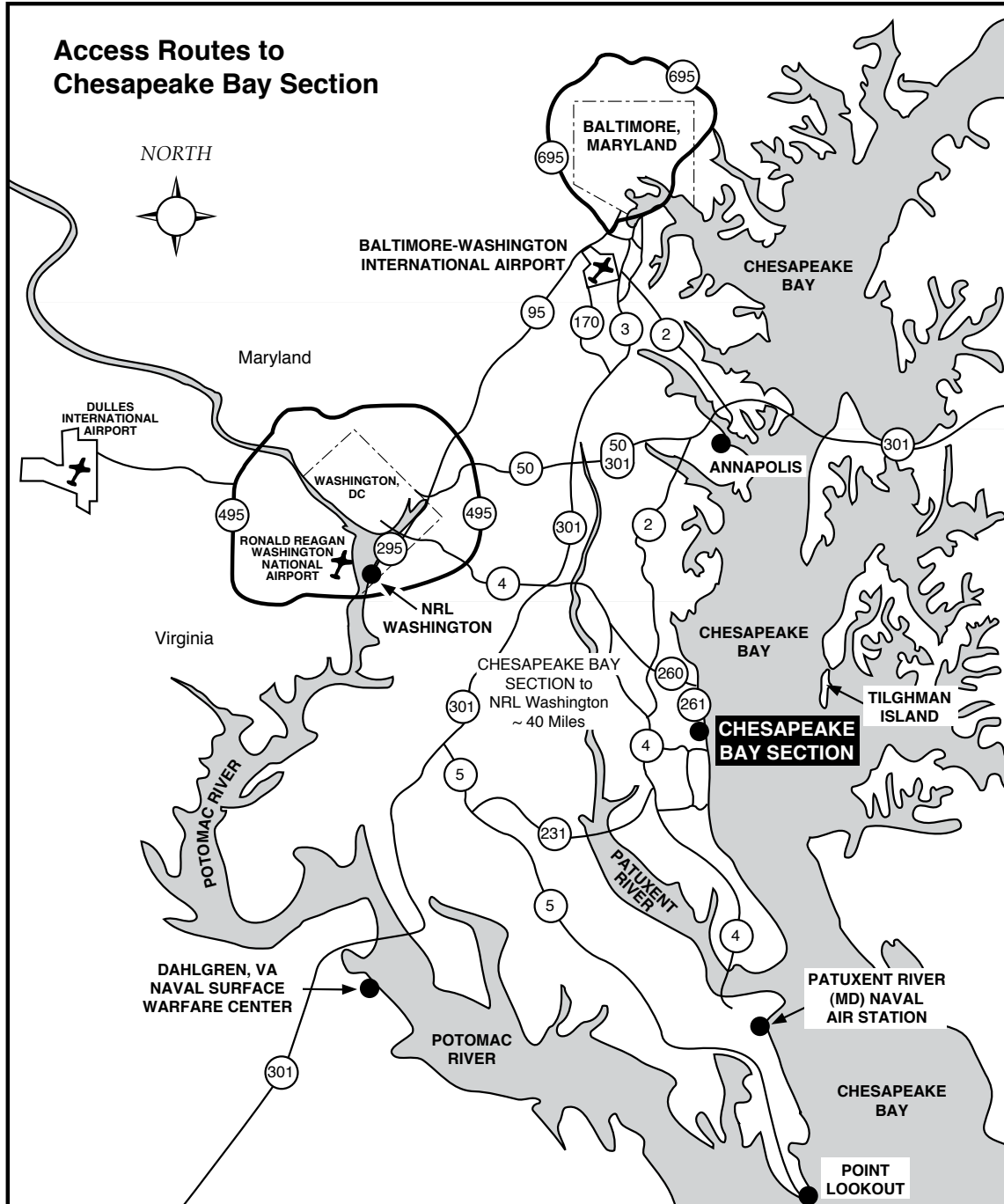

Naval Research Laboratory
 Chesapeake Bay Section
 5813 Bayside Road
 Chesapeake Beach, MD 20732
 (301) 257-4002

Location of Buildings at the Chesapeake Bay Section

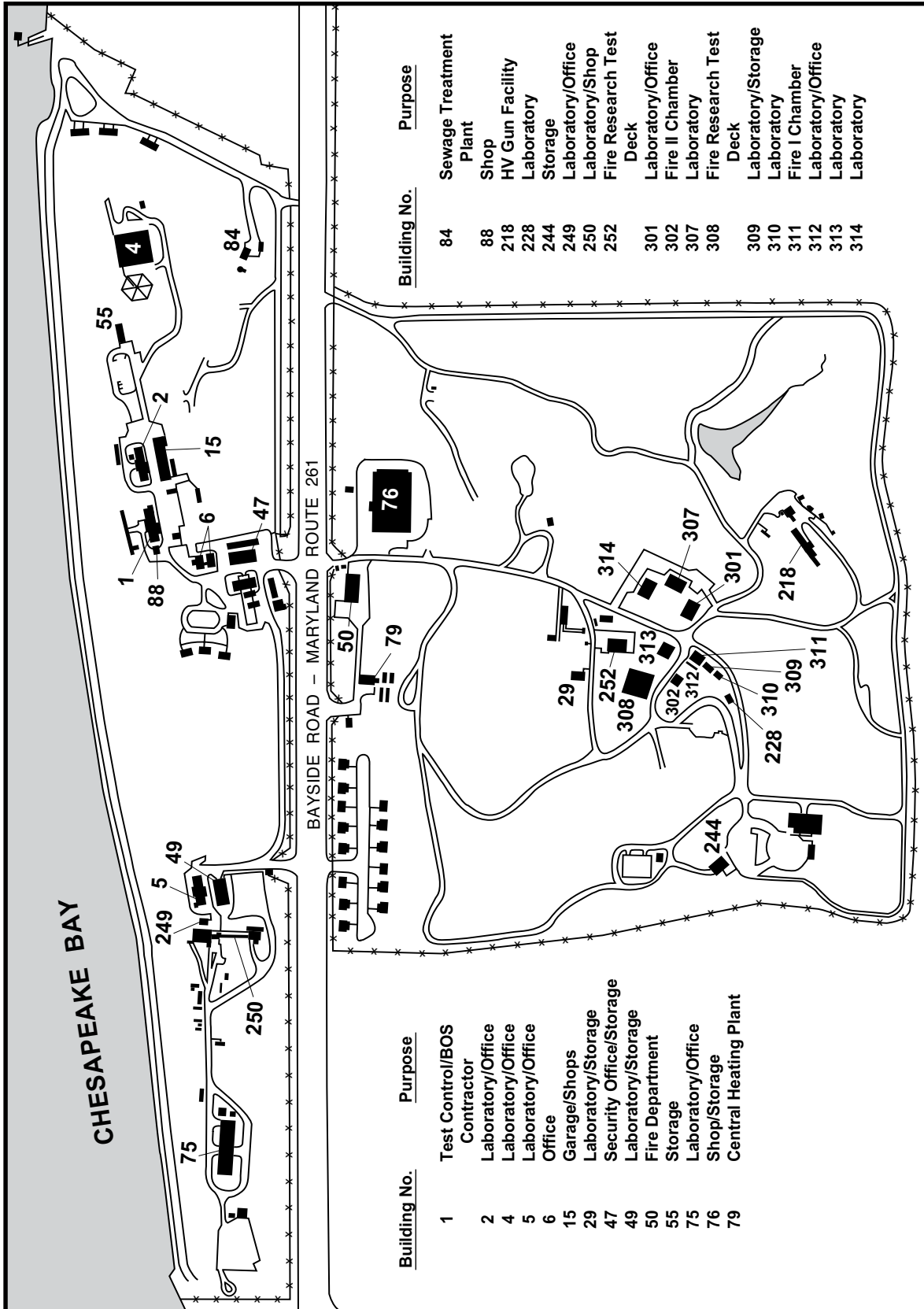

John C. Stennis Space Center (Stennis Space Center, Mississippi)

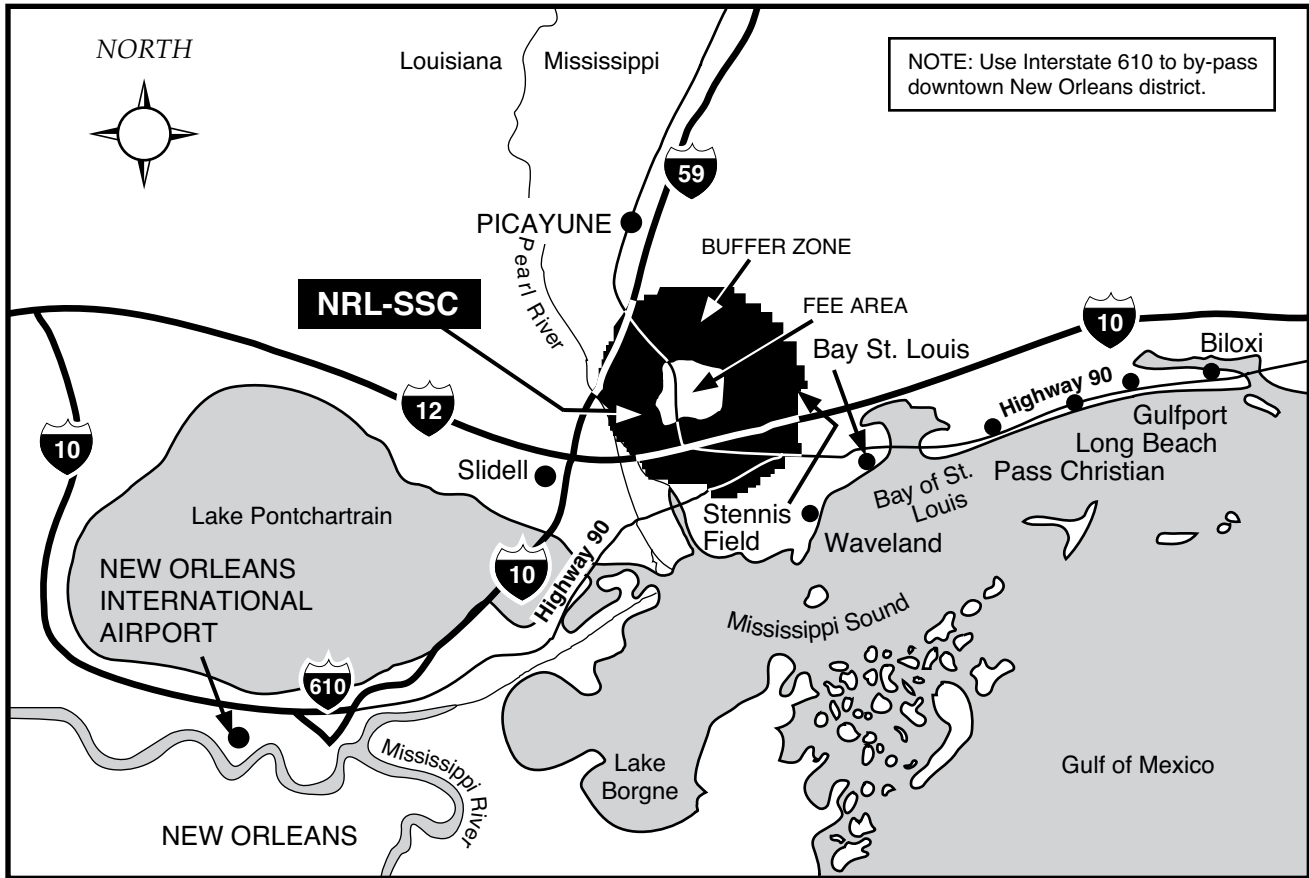

Naval Research Laboratory
John C. Stennis Space Center
Stennis Space Center, MS 39529-5004
(228) 688-3390

Naval Research Laboratory Monterey (Monterey, California)

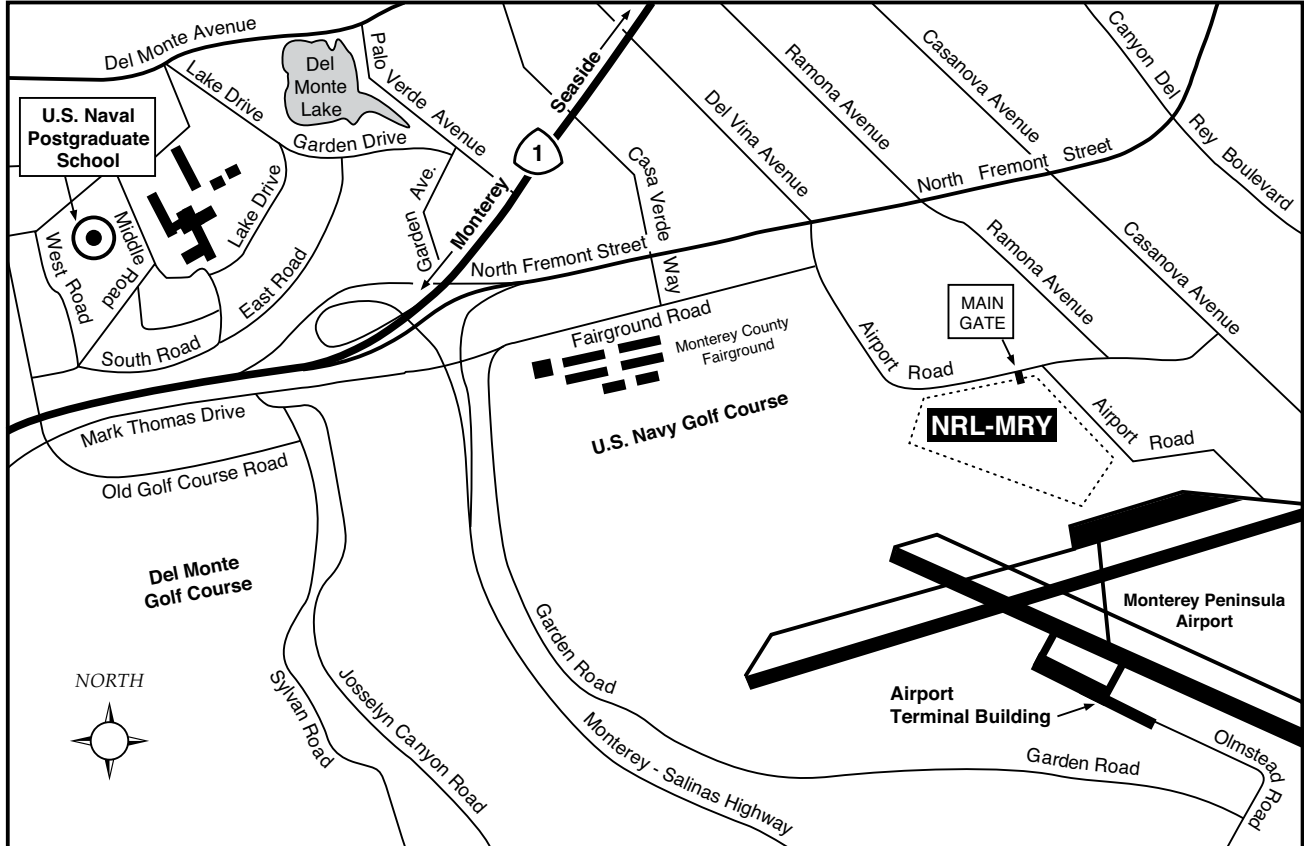

Naval Research Laboratory
Marine Meteorology Division
7 Grace Hopper Avenue
Monterey, CA 93943-5502
(831) 656-4721

Key Personnel

DSN: NRL Washington 297- or 754-; NRL/SSC 828-; NRL/Monterey 878-;
NRL VXS-1/Patuxent River 342-

Code **Telephone**

EXECUTIVE DIRECTORATE

1000	Commanding Officer	(202) 767-3403
1000.1	Inspector General	(202) 767-3621
1001	Director of Research	(202) 767-3301
1001.1	Executive Assistant to the Director of Research	(202) 767-2445
1001.2	Head, Strategic Workforce Planning	(202) 767-3421
1001.3	Executive Assistant for Technology Deployment	(202) 767-0851
1002	Chief Staff Officer	(202) 767-3621
1004	Head, Office of Technology Transfer	(202) 767-3083
1006	Head, Office of Program Administration and Policy Development	(202) 767-1312
1008	Head, Office of Counsel	(202) 767-2244
1030	Head, Public Affairs Office	(202) 767-2541
1100	Director, Institute for Nanoscience	(202) 767-1803
1200	Head, Command Support Division	(202) 767-3091
1400	Head, Military Support Division	(202) 767-2273
1600	Commanding Officer, Scientific Development Squadron One (PAX River NAS)	(301) 342-3751
1700	Director, Laboratory for Autonomous Systems Research	(202) 767-0792
1800	Director, Human Resources Office	(202) 767-8322
1830	Deputy Equal Employment Opportunity Officer	(202) 767-8390
3005	Deputy for Small Business	(202) 767-0666
3540	Head, Safety Branch	(202) 767-2232

BUSINESS OPERATIONS DIRECTORATE

3000	Associate Director of Research for Business Operations	(202) 767-2371
3005	Deputy for Small Business	(202) 767-0666
3030	Head, Management Information Systems Office	(202) 404-3659
3200	Head, Contracting Division	(202) 767-5227
3300	Head, Financial Management Division	(202) 767-3405
3400	Head, Supply and Information Services Division	(202) 767-3446
3500	Director, Research and Development Services Division	(202) 404-4054

SYSTEMS DIRECTORATE

5000	Associate Director of Research for Systems	(202) 767-3525
5300	Superintendent, Radar Division	(202) 404-2700
5500	Superintendent, Information Technology Division/NRL Chief Information Officer*	(202) 767-2903
5600	Superintendent, Optical Sciences Division	(202) 767-3171
5700	Superintendent, Tactical Electronic Warfare Division	(202) 767-6278

MATERIALS SCIENCE AND COMPONENT TECHNOLOGY DIRECTORATE

6000	Associate Director of Research for Materials Science and Component Technology	(202) 767-3566
6100	Superintendent, Chemistry Division	(202) 767-3026
6300	Superintendent, Materials Science and Technology Division	(202) 767-2926
6040	Director, Laboratories for Computational Physics and Fluid Dynamics	(202) 767-3055
6700	Superintendent, Plasma Physics Division	(202) 767-2723
6800	Superintendent, Electronics Science and Technology Division	(202) 767-3693
6900	Director, Center for Bio/Molecular Science and Engineering	(202) 404-6000

*Additional duty

DSN: NRL Washington 297- or 754-; NRL/SSC 828-; NRL/Monterey 878-;
NRL VXS-1/Patuxent River 342-

Code

Telephone

OCEAN AND ATMOSPHERIC SCIENCE AND TECHNOLOGY DIRECTORATE

7000	Associate Director of Research for Ocean and Atmospheric Science and Technology	(202) 404-8690
7030	Head, Office of Research Support Services	(228) 688-4010
7100	Superintendent, Acoustics Division	(202) 767-3482
7200	Superintendent, Remote Sensing Division	(202) 767-3391
7300	Superintendent, Oceanography Division	(228) 688-4670
7400	Superintendent, Marine Geosciences Division	(228) 688-4650
7500	Superintendent, Marine Meteorology Division	(831) 656-4721
7600	Superintendent, Space Science Division	(202) 767-6343

NAVAL CENTER FOR SPACE TECHNOLOGY

8000	Director, Naval Center for Space Technology	(202) 767-6547
8100	Superintendent, Space Systems Development Department	(202) 767-4593
8200	Superintendent, Spacecraft Engineering Department	(202) 404-3727

Technical Information Services Branch Production Staff



Editorial Assistance

Claire Peachey

Coordination, Design, and Layout

Jonna Atkinson

Photography

*Gayle R. Fullerton, James Marshall, and
Jamie Hartman*

The cooperation and assistance of others on the staffs of the Technical Information Services Branch and the Central Mail Processing Unit are also acknowledged and appreciated.

REVIEWED AND APPROVED

NRL/PU/3430--11-552

RN: 12-1231-4047

November 2012

Anthony J. Ferrari, Captain, USN
Commanding Officer



<http://www.twitter.com/USNRL>

facebook



NAVAL RECORDS



nrl.navy.mil

NRL FACT BOOK