

1.0 PURPOSE

To aid mine operators, their representatives, or mining equipment manufacturers applying for acceptance of Monitor and Power System (MAPS) installation schemes.

2.0 SCOPE

The MAPS acceptance program applies to mine operators or equipment manufacturers who want to install MSHA accepted ground wire monitor(s) in a manner that is not approved in the monitor manufacturer's acceptance. Extensions or other modifications of acceptance will not be accepted under the MAPS Program. Design changes affecting the MAPS label require a new MAPS acceptance. Minor documentation changes may be processed under the Revised Approval Modification Program (RAMP). Changes may not be made to an accepted ground wire monitor's internal circuitry. MAPS acceptances will be issued only to parties exhibiting control over the installation.

3.0 REFERENCES

- 3.1 STANDARD TEST PROCEDURE FOR ACCEPTANCE OF GROUND WIRE DEVICES, ASTP2134.
- 3.2 STANDARD TEST PROCEDURE FOR ACCEPTANCE OF GROUND WIRE MONITOR SYSTEMS, ASTP2135.

4.0 DEFINITIONS

- 4.1 Grounding Circuit Drawing - A required drawing that depicts the complete grounding circuit and the location of all ground wire monitor system components installed in an electrical power system.
- 4.2 Ground Wire Monitor and Ground Wire Device Installation Test - A test sequence conducted by the MAPS applicant or MSHA to determine if a ground wire monitor (GWM) installation will perform in a manner acceptable to MSHA according to 30 CFR Parts 75.524, 75.803, 75.902, 77.803, 77.902, 18.47(d)(2), and 18.50(b). An hourly rate fee is charged for all evaluation and tests conducted by MSHA.
- 4.3 Sectionalized Cable Circuit - A cable circuit whose grounding conductor connects to three or more metal frames which are not electrically insulated from earth ground or other grounded surfaces. (Example: A trailing cable or longwall cable containing grounded in-line cable couplers or connection boxes).

- 4.4 Non-Sectionalized Cable Circuit - A cable circuit whose grounding conductor connects to only two metal frames, not including frames electrically insulated from earth ground and other grounded surfaces. (Example: A trailing cable containing no grounded in-line cable couplers or connection boxes or a trailing cable containing grounded in-line cable couplers or connection boxes that have been electrically insulated from contact with the earth and all equipment frames).
- 4.5 Dropout Resistance - a quantity of resistance that when placed into the monitored circuit causes a ground wire monitor to initiate a tripping function.
- 4.6 Ground Wire Device (GWD) – A unit placed in series with the ground wire to suppress intermachine arcing or to reduce the effect of interfering parallel paths to the ground wire monitor.
- 4.7 MAPS Applicant – A mine operator, their representative, or a mining equipment manufacturer applying for acceptance of Monitor and Power Systems installations.
- 4.8 Pre-authorization Notice - A statement by the applicant authorizing MSHA to expend a stated amount of money in evaluating/testing the applicant's product prior to the preparation, issuance, and return of the MSHA fee estimate. When a pre-authorization notice is submitted and total charges are less than the pre-authorization amount, the lesser amount will be charged.

5.0 APPLICATION PROCEDURE

5.1 GENERAL

- 5.1.1 Upon receipt of an application, A&CC will provide an estimate of the total anticipated charges. A&CC will not continue with processing until receiving the applicant's response to the fee estimate letter, unless a pre-authorization notice is submitted with the application.
- 5.1.2 Upon successful completion of the tests and evaluation, a MAPS acceptance number will be issued by MSHA for the specific monitor and power system installation. A MAPS label with the MSHA Acceptance Number must be displayed on the power center or substation of the power system as near as practical to the circuit outlet that is described by the information submitted in the MAPS application. The applicant must provide a copy of the MAPS label, installation drawings, and written instructions to each user of the accepted MAPS for filing in the mine files at the mine location.

- 5.1.3 The ground wire monitors and ground wire devices utilized in MAPS applications must be previously accepted by MSHA.
- 5.1.4 Should assistance be required in completing the application form, contact the A&CC, Electrical Safety Division prior to actual submission of the application.
- 5.2 MAPS Documentation Required
 - 5.2.1 Applicants must provide all documents that will be distributed to users of the MAPS Acceptance. The distributed documents must be sufficient to enable the user to install and maintain the MAPS Acceptance. These documents must describe a MAPS acceptance label and its method of attachment.
 - 5.2.2 A completed MAPS application letter must be completed in accordance with Section 5.6 of this document.
 - 5.2.3 A grounding circuit drawing must be submitted that depicts the complete grounding circuit, all circuit components, and the location of all ground wire monitor system components installed in the electrical power system, including intermachine arc suppressing devices. If the circuit is typical of several other circuits in the system, only one representation of the circuit is necessary when the total number of circuits is identified. Refer to Appendix No. 2 for minimum required information on the grounding circuit drawing.
 - 5.2.4 Test results must be submitted corresponding to Figures 1 through 6 of the Ground Wire Monitor and Ground Wire Device Installation Test completed in accordance with Section 5.3.1 of this document and recorded on Appendix No. 1, if applicable.
 - 5.2.5 A ground fault current analysis must be completed in accordance with Section 5.3.3 of this document.
 - 5.2.6 A power system short-circuit study and an analysis of the GWD's short circuit current capabilities must be submitted. When the cable rating size of a GWD is smaller than the size cable used or where the nominal system voltage exceeds the voltage rating of the GWD, the magnitude of system phase-to-phase short circuit current calculated at the power center receptacle and the maximum short circuit clearing time shall not exceed the values at which the GWD was subjected during MSHA acceptance testing.
 - 5.2.7 MSHA reserves the right to require the submittal of additional information.
- 5.3 MAPS TEST AND ANALYSIS

All tests and analyses conducted by the applicant must be documented and given test identification numbers. Each test identification number shall begin with the first three letters of the company name, followed by the letters MAPS, a dash (-), and a sequential number assigned by the applicant. For example, the DLM Company test numbering sequence would be DLMMAPS-1, DLMMAPS-2, etc.

If an installation has been previously evaluated by the applicant and the test data is on file at MSHA, the applicant may reference the test number on the MAPS application without resubmitting data.

5.3.1 Ground Wire Monitor Dropout Resistance Test Procedure

This test procedure is for configurations using sectionalized cable circuits and provides documentation of the maximum dropout resistance of the ground wire monitors used in subsequent tests. Results of tests conducted under this section are recorded on the Ground Wire Monitor and Ground Wire Device Installation Test Data Sheet, Appendix No. 1. The sequence of testing must be followed exactly to produce reliable results.

5.3.1.1 The equipment required for this test is two complete ground wire monitor systems (this includes ground wire devices and peripheral components), four 0.3 Ω resistors, one 100 Ω ten turn potentiometer, six test leads, one volt-ohm meter, twelve 0.25 Ω resistors for pilot-wireless installation testing, and four 1.5 Ω resistors for pilot wire installation testing.

5.3.1.2 Connect two ground wire monitor systems in circuit configurations described by Figure No. 1 for pilot wire installations, or Figure No. 2 for pilot-wireless installations. Note that parallel paths are not installed during this test. Label the figure with the model numbers of the ground wire monitor and all peripheral components at the locations of the components. All ground wire devices must be installed in accordance with the manufacturer's instructions. Ground wire devices are not permitted to be installed inside cable couplers.

5.3.1.3 Calibrate only those monitors with front panel controls in accordance with the manufacturers' instructions.

5.3.1.4 Adjust a 100-ohm potentiometer to zero ohms and install the potentiometer in GND 10.

5.3.1.5 Increase the resistance of potentiometer until the control relay on Monitor No.1 just trips.

- 5.3.1.6 Remove the potentiometer and reconnect GND 10. Measure the resistance of the potentiometer and record it on data sheet 1 for GWM 1.
- 5.3.1.7 Repeat steps 5.3.1.4, 5.3.1.5, and 5.3.1.6 for GND 11.
- 5.3.1.8 Adjust the 100-ohm potentiometer to zero ohms and install it in GND 20.
- 5.3.1.9 Increase the resistance of potentiometer until the control relay on Monitor No. 2 just trips.
- 5.3.1.10 Remove the potentiometer and reconnect GND 20. Measure the resistance of the potentiometer and record it on data sheet 1 for GWM 2.
- 5.3.1.11 Repeat steps 5.3.1.8, 5.3.1.9, and 5.3.1.10 for GND 21.
- 5.3.1.12 The measured resistance of the potentiometer in Sections 5.3.1.6, 5.3.1.7, 5.3.1.10, or 5.3.1.11 cannot be greater than 50 ohms. If the monitor fails to trip at 50 ohms or less at any time, the ground wire monitor is defective and must be repaired or replaced before proceeding with any subsequent tests.
- 5.3.2 Open Ground Wire Test
- This test verifies the GWM's effectiveness at monitoring the continuity of the ground wire. Results of tests conducted under this section are recorded on Appendix No. 1, Ground Wire Monitor and Ground Wire Device Installation Test Data Sheet," under Open Ground Wire Test.
- 5.3.2.1 Monitors of different manufacturers and model numbers must be tested to insure that all possible combinations of manufacturers and model numbers are tested even if the test circuit must be expanded to include more than two ground wire monitors. At least two circuits must be installed and operating during the testing sequence.
- 5.3.2.2 Install 2 ground wire monitors in accordance with Figure 3 or Figure 4 connecting parallel paths PP10, PP11, PP20, PP21, PPMF, and PPCF.
- 5.3.2.3 Open GND 10 and record response for both GWM's under Data Sheet 2 section.
- 5.3.2.4 Re-close GND 10.
- 5.3.2.5 Open GND 11 and record response for both GWM's under Data Sheet 2 section.

5.3.2.6 Re-close GND 11.

5.3.2.7 Open GND 20 and record response for both GWM's under Data Sheet 2 section.

5.3.2.8 Re-close GND 20.

5.3.2.9 Open GND 21 and record response for both GWM's under Data Sheet 2 section.

5.3.2.10 Re-close GND 21.

5.3.2.11 Monitor(s) that tripped when both sections of their associated cable GND wires were opened, GND 10 and 11 for monitor 1 and GND 20 and 21 for monitor 2, exclusively monitor the ground wire for continuity. If monitor 1 and monitor 2 failed to trip when either section of their associated cable GND wire was opened, this ground wire monitor must be evaluated as an impedance-type ground wire monitor or the application fails.

5.3.2.12 If the ground wire monitors are impedance-type monitors, open parallel paths PP10, PP11, PP20, and PP21. Open GND10, GND11, GND20, and GND 21 with the polarity switches in the same direction. Repeat with the polarity switches in the opposite direction. Record response for both GWM's under Data Sheet 2 section.

5.3.2.13 Reclose parallel paths and ground wires

5.3.2.14 If the ground wire monitors are continuity type monitors, open parallel paths PP10, PP11, PP20, and PP21. Open GND10, GND11, GND20, and GND 21. Record response for both GWM's under Data Sheet 2 section

5.3.2.15 If either monitor failed to trip in 5.3.2.12, or 5.3.2.14 the application fails.

5.3.3 Ground Fault Current Analysis

This test procedure is for all installation configurations and all types of ground wire monitors.

5.3.3.1 Determine the value of the neutral grounding resistor in ohms (R_{NGR}).

5.3.3.2 Add the total of all resistances that can appear external to the neutral grounding resistor. This includes the dropout resistance of all impedance-type ground wire monitors and continuity-type monitors that are being evaluated as impedance-type monitors, ground conductor resistance, etc. A trip resistance of 50 ohms is used

for all continuity-type ground wire monitors. The trip resistance for impedance-type ground wire monitors can be obtained from the original acceptance records.

5.3.3.3 The sum of all resistances that can appear external to the neutral grounding resistor must be less than the value of the neutral grounding resistor. This ensures that the ground fault current will always be greater than one-half of the grounding resistor current rating.

5.3.3.4 The system must be provided ground fault protection adjusted to operate on as low a value of fault current as practical, but not more than 50 percent of the current rating of the neutral grounding resistor.

5.4.4 Frame Voltage Calculation

The saturation voltage of ground wire devices installed for inter-machine arcing or parallel path isolation purposes will add a voltage to the total voltage developed across the grounding conductor during grounded phase conditions. This voltage is determined based on the maximum available ground fault current and can be obtained from A&CC records.

5.4.4.1 Draw a One-Line diagram of the grounding circuit as described in Appendix No. 3. Begin at the source transformer where the neutral grounding resistor is installed and proceed to the farthest point of the system. Include the source transformer, the neutral grounding resistor, all ground wire devices, the cable resistance for continuity-type ground wire monitors or the dropout resistance for each impedance-type ground wire monitor or continuity-type ground wire monitor evaluated as an impedance-type ground wire monitor in the circuit.

5.4.4.2 Obtain the saturation voltage for each ground wire device installed in the grounding circuit.

5.4.4.3 Calculate the potential voltage that can appear on the machine frame. Appendix No. 3 shows sample formulae and Figures 5 and 6 are examples.

5.4.4.4 If the calculated voltage exceeds 40 volts, this arrangement cannot be used as a MAPS circuit.

5.5.5 Low- and medium- voltage rated GWMs must be equipped with adequate transient protection provided at the pilot and ground wire terminals of the GWM to be used on high voltage systems.

5.6 Information required in the MAPS Application letter.

- 5.6.1 The name and address of the company applying for the MAPS Acceptance.
- 5.6.2 The name of the company official to whom all correspondence is to be addressed.
- 5.6.3 A company-assigned application code number. This is a numerical code (up to six digits) assigned by the applicant for identification purposes. **Note that this number cannot be duplicated in future applications.**
- 5.6.4 The identification number of the GWM/GWD installation test or tests that show the GWM's, GWD's, and all combination of GWM's and GWD's, that are requested in the installation.
- 5.6.5 The maximum phase-to-phase short circuit current at the power center's receptacle. This calculation must be made for each voltage supplied by the power center. Tabulate the current and voltage on the application form (i.e. current vs. voltage).
- 5.6.6 The maximum clearing time beginning at the inception of short circuit current until a protective device de-energizes the power circuit. Tabulate the current and clearing time in the application letter (i.e. current vs. time).
- 5.6.7 The ground fault relay trip setting for each cable.
- 5.6.8 A statement signed and dated by a responsible company official stating that the company will maintain records traceable to each MAPS acceptance issued to the company to insure that each MAPS installation meets all MSHA regulations and safety requirements.
- 5.7 MAPS ACCEPTANCE LABEL DESIGN
 - 5.7.1 A MAPS acceptance label must be affixed to the power center, etc. in a visible location as near as practical to the circuit outlet described by the Acceptance (affixed to the circuit plug or receptacle is also acceptable). The label may be made of a self-adhesive type material
 - 5.7.2 When the electrical installation changes or the power center is modified, the MAPS label must be removed (or destroyed if not removable). When the MAPS is reinstalled at another location, another label must be installed at that location to identify the MAPS circuit.
 - 5.7.3 A sample label design is included in this section. The label must include at least the following information:

5.7.3.1 MSHA Logo.

5.7.3.2 Space for MSHA MAPS Acceptance Number.

5.7.3.3 A narrative description of the ground wire monitors and related system components of the monitoring system.

5.7.3.4 A sample follows.



MAPS APPLICANT COMPANY
MONITOR AND POWER SYSTEM ACCEPTANCE

MAPS-01010101

Power Center Requirements

Nominal System Secondary Voltage = 2400 volts
Maximum Short Circuit Current = 16,000 Amperes
Maximum Circuit Interrupt Time = 0.30 Seconds
Maximum Ground Fault Current = 0.500 Amperes
Maximum Ground Fault Trip Setting = 0.125 Amperes

Continuous Mining Machine Requirements

Trailing Cable May Include
MSHA Certified In-Line Connection Boxes or
MSHA Certified In-Line Cable Couplers

Ground Wire Monitor Requirements

Ground Wire Monitor Corporation
MSHA Acceptance No: 010101GM-001
Pilot Wire Device: 01-0101-01, or A0101-001
Ground Wire Device: B-MSHA-1, or B-MSHA-2

APPENDIX No. 1

Ground Wire Monitor and Ground Wire Device Installation Test Data Sheet 2

Data Sheet 1; Monitor’s trip Resistance:

GWM dropout resistance (ohms)

GWM 1 _____
 GWM 2 _____

Data Sheet 2; Open Ground Wire Test:

Record “T” when control relay trips and “NT” when control relay does not trip.

Monitor Response

Open GND 10 Open GND 11

GWM 1 _____ _____
 GWM 2 _____ _____

Open GND 20 Open GND 21

GWM 1 _____ _____
 GWM 2 _____ _____

For steps 5.3.2.12 or 5.3.2.14 did both GWM1 and GWM2 trip? _____

Company Official _____ Date _____

GWM/GWD Installation Test Identification Number

APPENDIX No. 2

A Grounding Circuit Drawing must contain at least the following information:

1. A representation of each electrical enclosure containing one or more ground wire monitors.
2. The representation of each cable exiting each electrical enclosure.
3. A representation of all in-line cable couplers, distribution boxes, connection boxes, and machines monitored.
4. The size (AWG) and length of each cable exiting each electrical enclosure.
5. The acceptance numbers of all ground wire monitors, model and part numbers of all peripherally located ground wire monitor components, and model and part numbers of all ground wire devices for each circuit included in the MAPS system.
6. The location of all ground wire monitors, their peripherally located components, and ground wire devices.
7. The nominal phase-to-phase voltage supplied to each cable exiting each electrical enclosure.
8. The maximum short circuit current available at the output receptacle for each receptacle, if different.
9. The total circuit clearing time for the maximum short circuit current of each circuit interrupter, if different.
10. The value in ohms and percent tolerance of the neutral grounding resistor(s) installed in the MAPS circuit(s).
11. The maximum available system ground fault current.
12. The maximum trip setting of the ground fault tripping relay.
13. The location of all couplers associated with each cable.
14. The statement "Changes in design must be approved by MSHA before being applied to approved equipment".
15. Company name, title, drawing number, sheet number (if a multiple sheet drawing, e.g. sheet 1 of 2), date, and latest revision level must be placed on each drawing.

NOTE: Only one representation of a redundant circuit needs to be included on the drawing if a notation is made specifying the exact quantity of the redundant circuits.

APPENDIX No. 3

An example:

1. Construct a one-line drawing of the circuit for the MAPS application. A sample drawing is shown in Figure No. 5.
2. Draw a schematic diagram of the grounding circuit; Figure No. 6 is a schematic diagram of the sample drawing in Figure No. 5. Begin at the source transformer where the neutral grounding resistor is installed and proceed to the farthest point of the system. Include the source transformer, the neutral grounding resistor, the resistance of the grounding conductor or the dropout resistance for each impedance-type ground wire monitor or continuity-type ground wire monitor evaluated as an impedance-type ground wire monitor, and all ground wire devices.
3. Calculate the potential voltage that can appear on the machine frame. Descriptively the frame voltage that a miner can potentially be exposed is the sum of the voltage drops across the resistance of grounding conductor No. 1 (R_{g1}) or the dropout resistance of ground wire monitor No. 1 (R_{do1}), the resistance of grounding conductor No. 2 (R_{g2}) or the dropout resistance of ground wire monitor No. 2 (R_{do2}), plus the saturation voltage of ground wire devices No. 1 (V_{sat1}) and No. 2 (V_{sat2}).

Calculations:

$$V_{frame} = V_{\phi-n} ((R_{g1} \text{ or } R_{do1} + R_{g2} \text{ or } R_{do2}) / (R_{ngr} + R_{g1} \text{ or } R_{do1} + R_{g2} \text{ or } R_{do2})) + V_{sat1} + V_{sat2}$$

The typical resistance of a grounding conductor in a longwall power cable is approximately 0.5 ohms. The dropout resistance of a continuity ground wire monitor is 50 ohms. The resistance of a neutral grounding resistor on a 4160 volt, .5 ampere grounded system is 4800 ohms. Assume a ground wire device with a saturation voltage of 9.4 volts at 0.5 ampere. The ground wire monitor between the power center and the longwall controller does not have a coupler. It is a non-sectionalized cable circuit. This ground wire monitor does not need to be evaluated to simulate an impedance-type ground wire monitor. So

$$R_{g1} = R_{g2} = 0.5 \Omega,$$

$$R_{do1} = N/A$$

$$R_{do2} = 50 \Omega, \text{ and}$$

$$V_{sat1} = V_{sat2} = 9.4 \text{ volts.}$$

If we substitute these values into our equation, we have

$$V_{frame} = 2400((0.5 + 50) / (4800 + 0.5 + 50)) + 9.4 + 9.4 \text{ volts}$$

$$V_{frame} = 44 \text{ volts.}$$

Since this value exceeds the limits set forth in 30CFR 18.40(b) or 40 volts, this circuit does not meet the requirements of the MAPS program. Modifications to the circuit are required so that the frame voltage does not exceed 40 volts. This could be accomplished by using a ground wire device which has a saturation voltage of 0.2 volts at 0.5 ampere. The frame voltage would then be 25 volts.

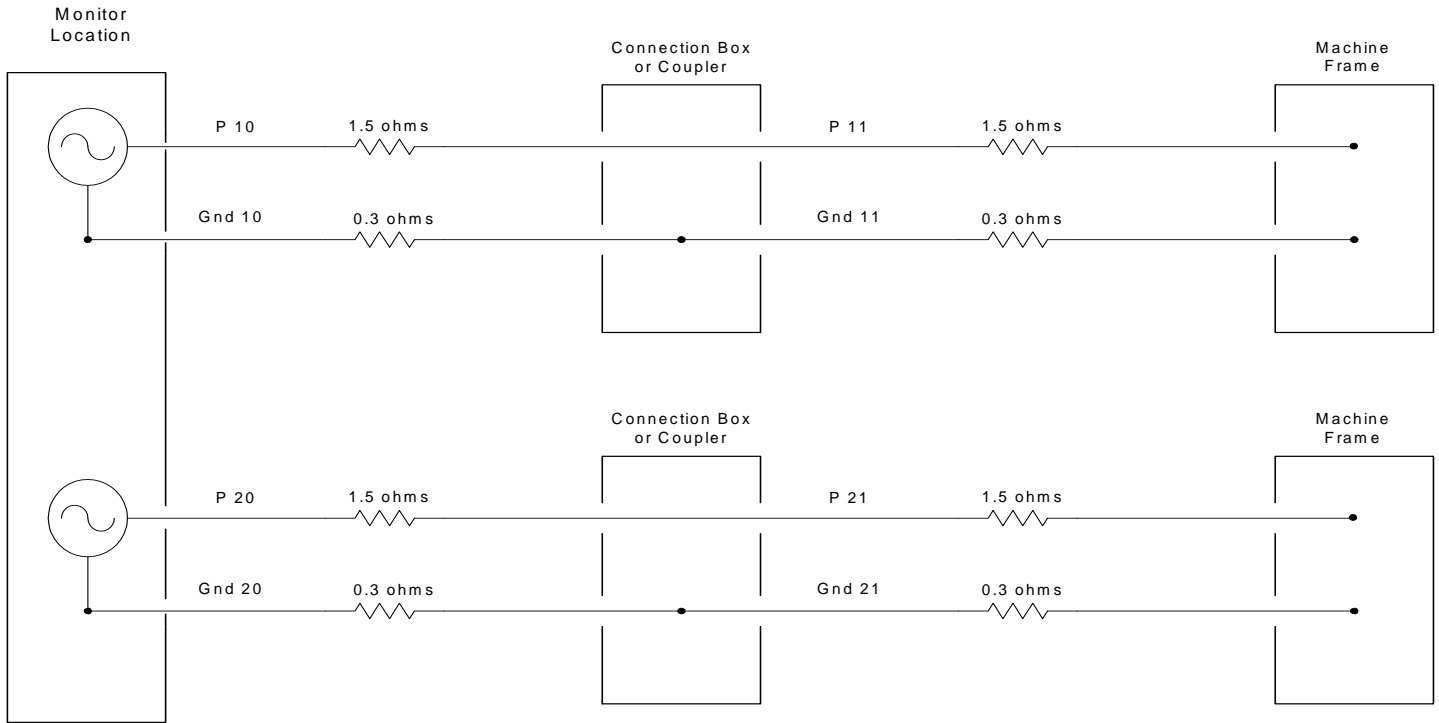

Pilot Wire Installation
Without Parallel Paths Shown
Figure No. 1

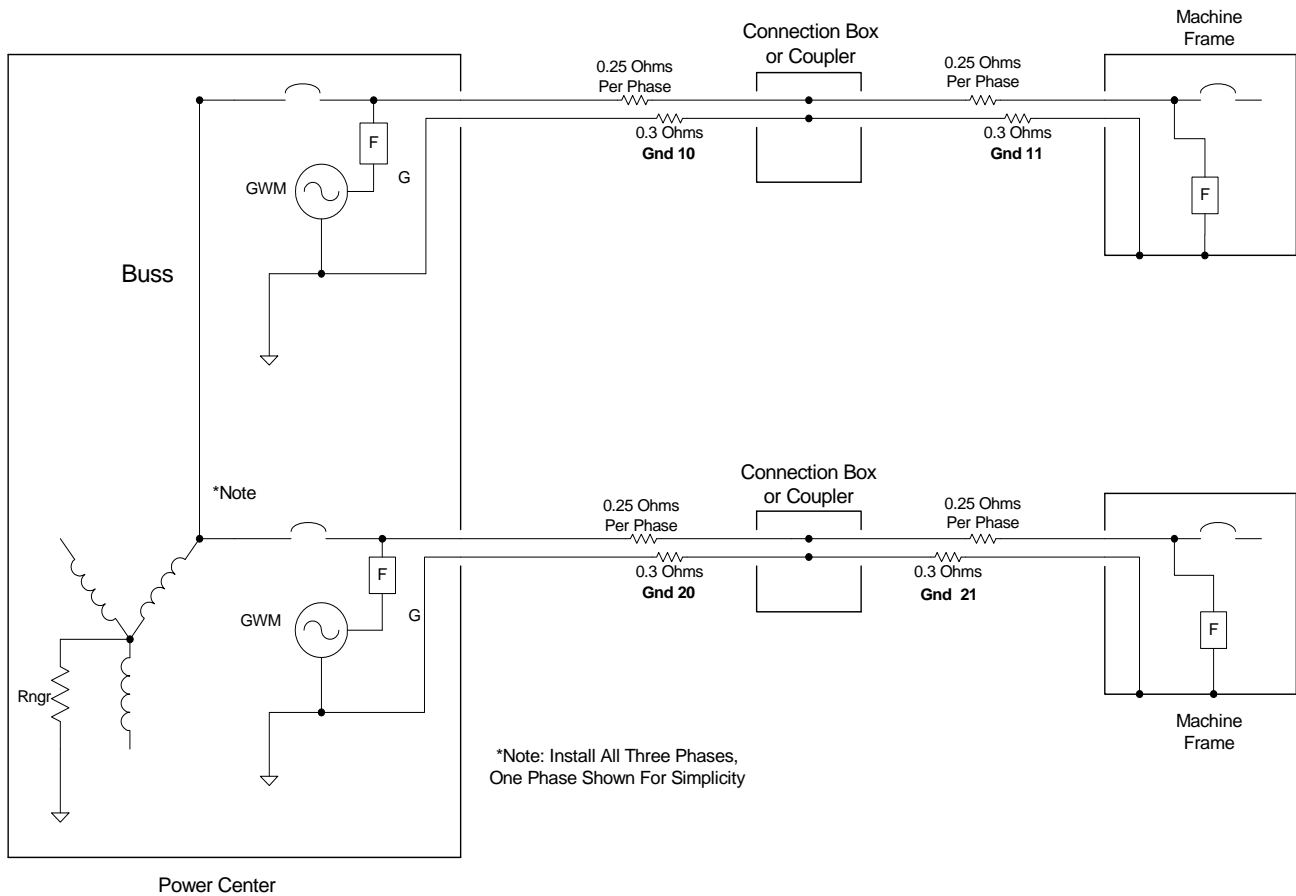

Pilot-Wireless Installation
 Without Parallel Paths Shown
 Figure No. 2

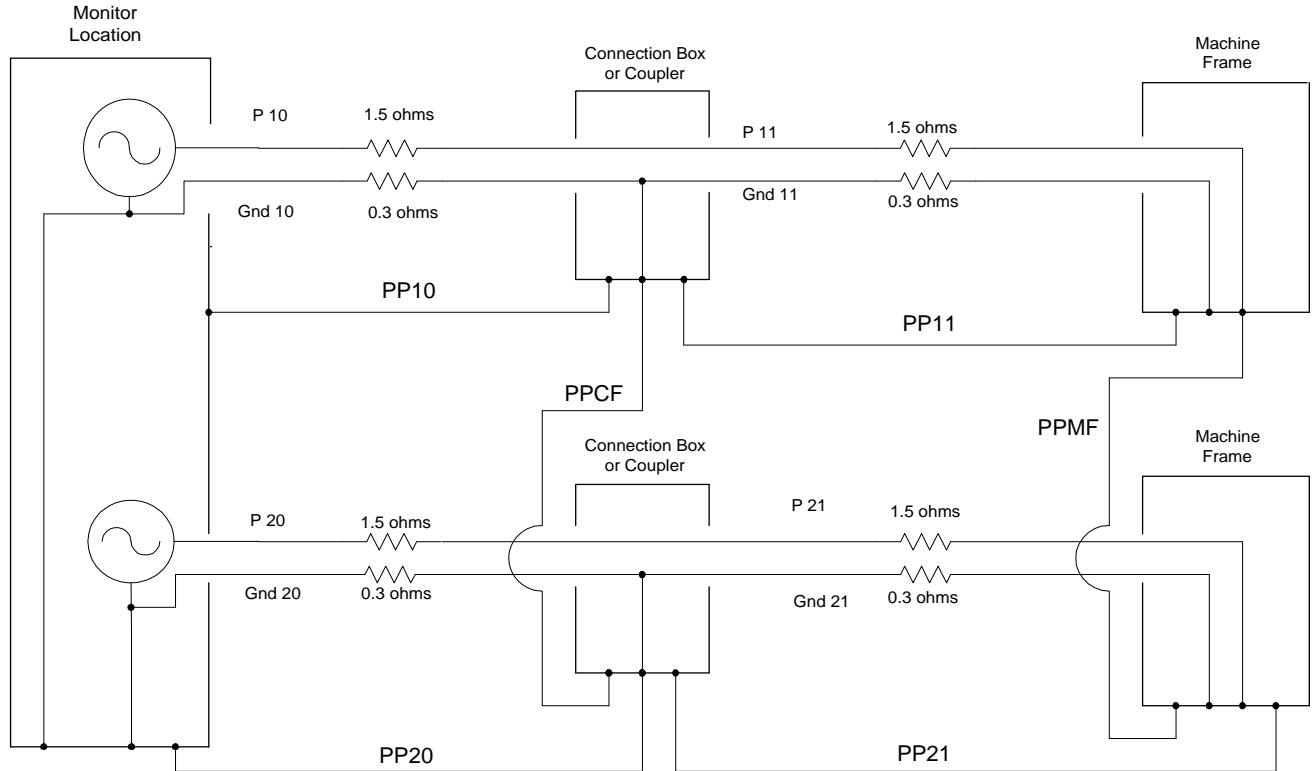

Pilot Wire Installation
 With Parallel Paths Shown
 Figure No. 3

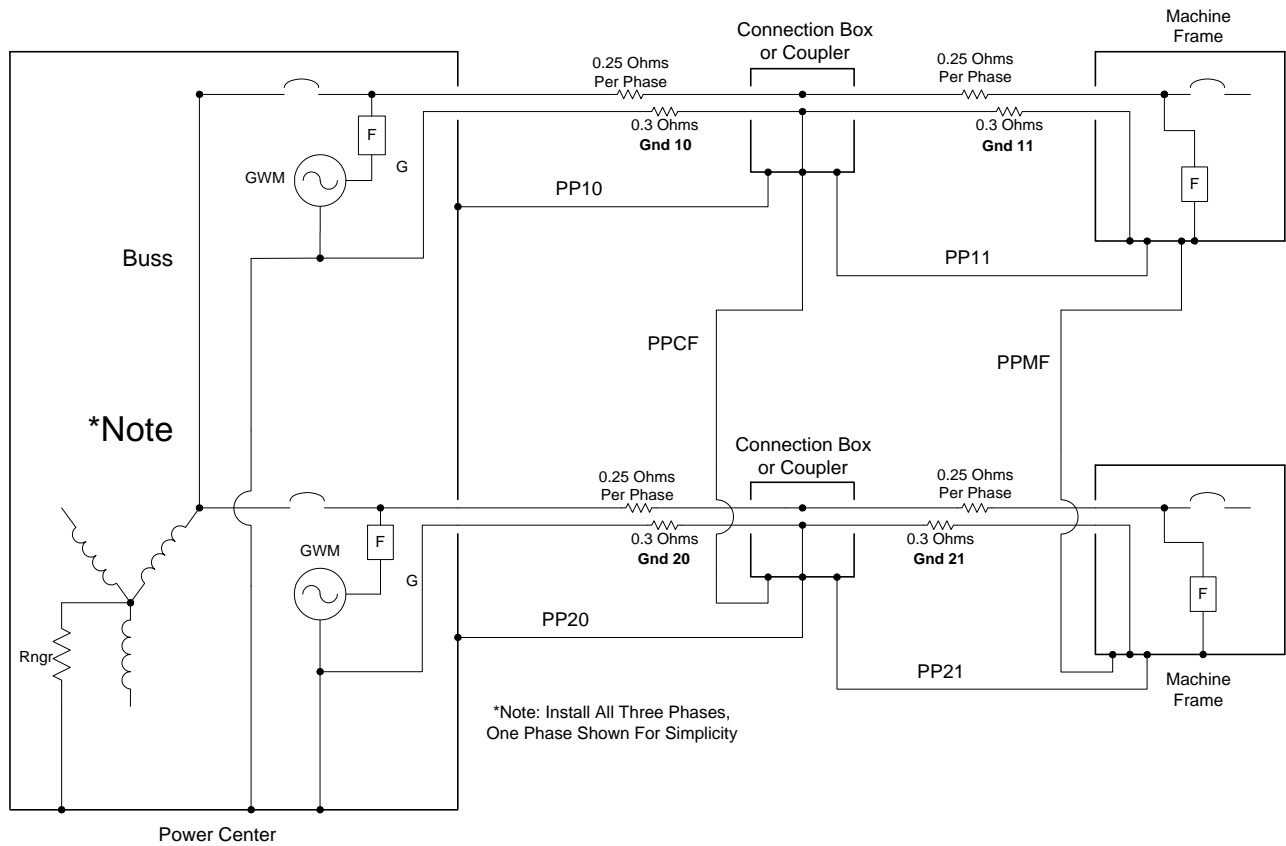

Pilot-Wireless Installation
 With Parallel Paths Shown
 Figure No. 4

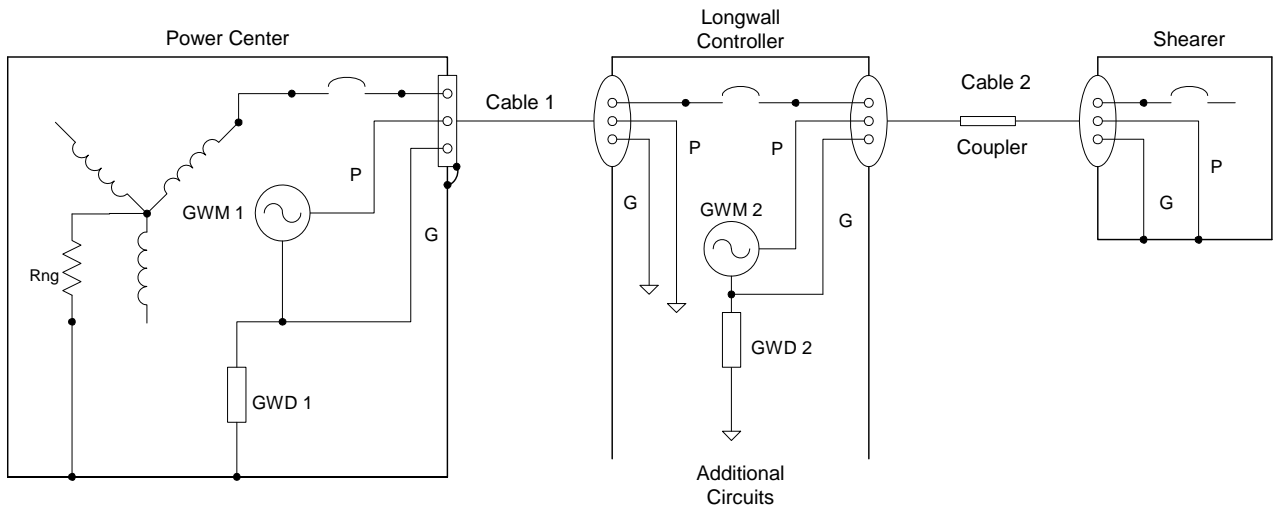

Shearer Circuit
 Frame Voltage Example
 Figure No. 5

TITLE: APPLICATION PROCEDURES FOR MONITOR AND POWER SYSTEMS (MAPS) ACCEPTANCES

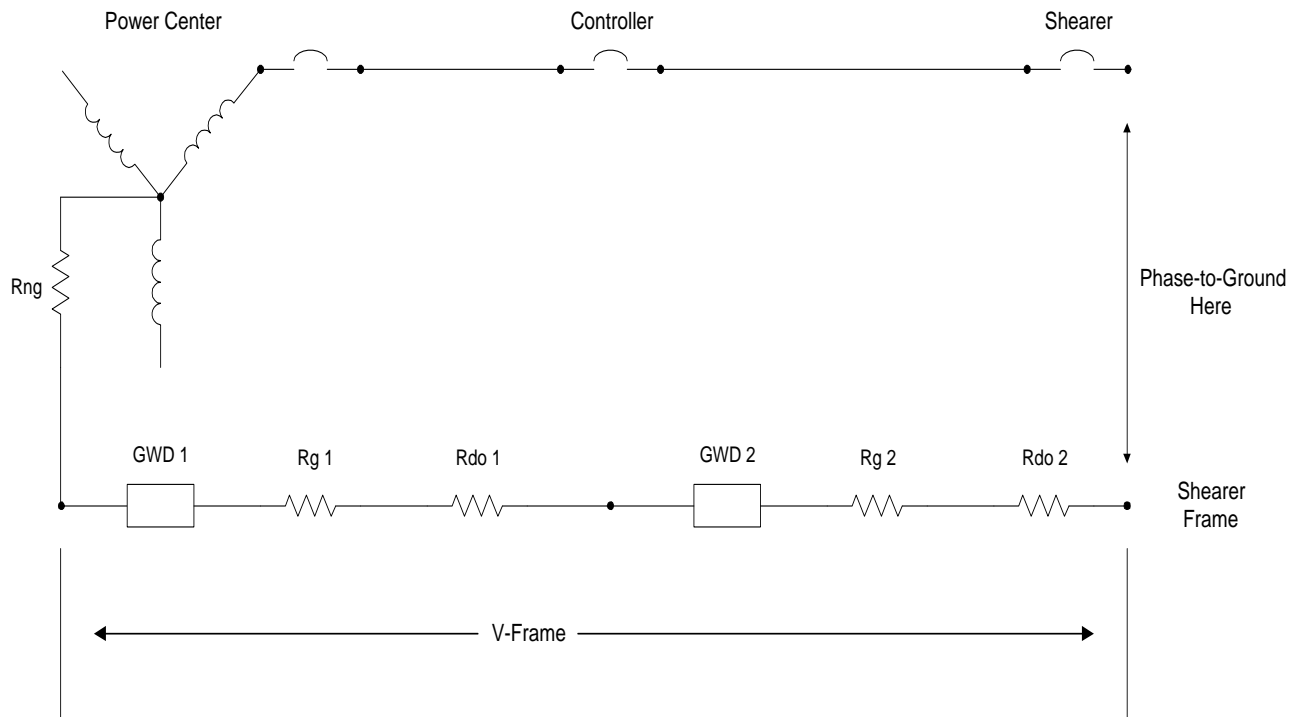

Frame Voltage Schematic
Figure No. 6