



**NATIONAL ENERGY TECHNOLOGY LABORATORY**



**Fossil Energy Power Plant Desk  
Reference Revision 1:  
*Bituminous Coal and Natural Gas to  
Electricity***

---

October 18, 2011

DOE/NETL-2011/1516

**Preliminary – Do Not Cite or Quote**



## **Disclaimer**

This report was prepared as an account of work sponsored by an agency of the United States Government. Neither the United States Government nor any agency thereof, nor any of their employees, makes any warranty, express or implied, or assumes any legal liability or responsibility for the accuracy, completeness, or usefulness of any information, apparatus, product, or process disclosed, or represents that its use would not infringe privately owned rights. Reference therein to any specific commercial product, process, or service by trade name, trademark, manufacturer, or otherwise does not necessarily constitute or imply its endorsement, recommendation, or favoring by the United States Government or any agency thereof. The views and opinions of authors expressed therein do not necessarily state or reflect those of the United States Government or any agency thereof.

---

**Fossil Energy Power Plant Desk Reference**  
**Revision 1:**  
*Bituminous Coal and Natural Gas to Electricity*

**DOE/NETL-2011/1516**

**October 18, 2011**

**NETL Contact:**

**James Black**  
**General Engineer**  
**Office of Program Planning and Analysis**

**National Energy Technology Laboratory**  
**[www.netl.doe.gov](http://www.netl.doe.gov)**

---

**Prepared by:**

**Energy Sector Planning and Analysis (ESPA)**

**Mark Woods  
Booz Allen Hamilton, Inc.**

**Vincent Chou  
Booz Allen Hamilton, Inc.**

**Kelly Scarff  
Booz Allen Hamilton, Inc.**

**DOE Contract Number DE-FE0004001**

---

## Acknowledgments

This report was prepared by Energy Sector Planning and Analysis (ESPA) for the United States Department of Energy (DOE), National Energy Technology Laboratory (NETL). This work was completed under DOE NETL Contract Number DE-FE0004001. This work was performed under ESPA Task 341.01.18.

The authors wish to acknowledge the contributions of the NETL staff, both federal and contractor, that prepared the "Cost and Performance Baseline for Fossil Energy Plants, Volume 1: Bituminous Coal and Natural Gas to Electricity," which is the basis for this Desk Reference.

John Wimer, Director of Office of Program Planning Analyses

Larry Rath, Director of Performance Division

James Black

Lisa Nichols

Daniel Cicero

Jared Ciferno

Kristin Gerdes

Eric Grol

Jeffrey Hoffmann

Julianne Klara

Patrick Le

Michael Matuszewski

Sean Plasynski

Wally Shelton

Gary Stiegel

William Summers

Thomas Tarka

Maria Vargas

Norma J. Kuehn

Booz Allen Hamilton, Inc.

Marc J. Turner

Booz Allen Hamilton, Inc.

Vasant Shah

Booz Allen Hamilton, Inc.

Lora L. Pinkerton

WorleyParsons Group, Inc.

Elsy Varghese

WorleyParsons Group, Inc.

---

## Preface

The goal of Fossil Energy (FE) research, development, and demonstration (RD&D) is to ensure the availability of ultra-clean, abundant, low-cost, domestic electricity to fuel economic prosperity and strengthen energy security. A broad portfolio of technologies is being developed within the Clean Coal Program to accomplish this objective. Ever increasing technological enhancements are in various stages of the research “pipeline,” and multiple paths are being pursued to create a portfolio of promising technologies for RD&D and eventual deployment.

To benchmark the progress of Clean Coal RD&D, it is essential to establish a baseline for comparing the performance of today’s fossil energy plant technologies: Pulverized Coal (PC) Combustion, Integrated Gasification Combined Cycle (IGCC), and Natural Gas Combined Cycle (NGCC). The National Energy Technology Laboratory (NETL) commissioned an in-depth analysis to estimate the performance and cost of state-of-the-art power plants taking into account the technological progress in recent years as well as dramatic escalation in labor and material costs. This desk reference provides a brief summary of the performance and cost estimates presented in the report “Cost and Performance Baselines for Fossil Energy Plants, Vol. 1, DOE/NETL-2010/1397.” The plants use either bituminous coal or natural gas to generate electricity using technology that is available today or within the next couple of years. All cases analyzed in the study were also designed with carbon dioxide (CO<sub>2</sub>) capture, so that the cost and performance penalties could be estimated and benchmarked.

A key objective of this study was to provide an accurate, independent assessment of the cost and performance of the subject fossil energy plants. Accordingly, while input was sought from various technology vendors, the final assessment of performance and cost was determined independently, and may not represent the views of the technology vendors.

The Bituminous Baseline Report, issued in 2008, was revised in 2010 to incorporate new performance and cost data as well as to implement new financial assumptions for state-of-the-art power plants.

Steady-state simulations using the Aspen Plus (Aspen™) modeling program were used to generate mass and energy balance data to assess system performance and size equipment. Performance and process limits were based upon published reports, information obtained from vendors and users of the technology, cost and performance data from design/build utility projects, and/or best engineering judgment. Capital and operating costs were estimated by WorleyParsons based on simulation results and through a combination of vendor quotes, scaled estimates from previous design/build projects, or a combination of the two.

This desk reference summarizes the results at the three levels listed below, allowing the user to focus on the level of detail desired.

---

## Overview

A top-level overview of all three technologies is provided with and without CO<sub>2</sub> capture.

## Technology-Level

The technology-level summaries provide more detail by comparing like-technologies both with and without CO<sub>2</sub> capture:

- IGCC Technology (GE Energy, ConocoPhillips E-Gas, Shell)
- PC Combustion Technology (sub- and super-critical)
- NGCC Technology

## Plant-Level

Plant-level summary sheets provide the most detail by describing each technology and configuration in terms of technical, economic, and environmental design basis. A plant description is outlined in some detail for each case, including mass and heat balance, efficiency, capital and operating costs, cost-of-electricity (COE), and cost of avoided CO<sub>2</sub> (if capture is included).

## Colors

Each technology is represented by a different color scheme for easy reference:

- Orange - Overview
- Green - IGCC Technology
- Red - PC Combustion Technology
- Blue - NGCC Technology

## Links

The following link provides access to digital files of the full Bituminous Baseline Report for all available volumes as well as the desk reference, an interactive tool, and a PowerPoint presentation:

[http://www.netl.doe.gov/energy-analyses/baseline\\_studies.html](http://www.netl.doe.gov/energy-analyses/baseline_studies.html)

---

This page intentionally left blank.

---



## Table of Contents

Overview of Bituminous Baseline Study

IGCC Plants With and Without Carbon Capture and Sequestration

*GE Energy IGCC Plant*

*GE Energy IGCC Plant With Carbon Capture and Sequestration*

*ConocoPhillips E-Gas™ IGCC Plant*

*ConocoPhillips E-Gas™ IGCC Plant With Carbon Capture and Sequestration*

*Shell IGCC Plant*

*Shell IGCC Plant With Carbon Capture and Sequestration*

Pulverized Coal Plant With and Without Carbon Capture and Sequestration

*Subcritical Pulverized Coal Plant*

*Subcritical Pulverized Coal Plant With Carbon Capture and Sequestration*

*Supercritical Pulverized Coal Plant*

*Supercritical Pulverized Coal Plant With Carbon Capture and Sequestration*

Natural Gas Combined-Cycle Plants With and Without Carbon Capture and Sequestration

*Natural Gas Combined-Cycle Plant*

*Natural Gas Combined-Cycle Plant With Carbon Capture and Sequestration*

This page intentionally left blank.

## Overview of Bituminous Baseline Study

### Objective and Description

The objective of the *Cost and Performance Baseline for Fossil Energy Plants; Volume 1 (Bituminous Coal and Natural Gas to Electricity)* is to determine cost and performance estimates of the near-term commercial offerings for power plants, both with and without current technology for carbon capture and sequestration (CCS). The study uses consistent design requirements for all technologies examined, as well as up-to-date performance and capital cost estimates. The study timeframe focuses on plants with construction begun in 2007. Coal plants would be commissioned in 2012 and natural gas plants commissioned in 2010. Each plant is built at a greenfield site in the midwestern United States.

The fossil energy plant cost and performance estimates presented in the study can be used as a baseline for additional comparisons and analyses. These systems analyses are a critical element of planning and guiding federal fossil energy research, development, and demonstration.

Twelve different power plant configurations were analyzed in the Bituminous Baseline Study. These six configurations included integrated gasification combined-cycle (IGCC) cases utilizing General Electric Energy (GEE), ConocoPhillips (CoP), and Shell gasifiers; four pulverized coal (PC) cases, two subcritical and two supercritical, and two natural gas combined-cycle (NGCC) plant cases. Each configuration was analyzed with and without CCS. The study matrix is provided in Table 1.

### Assumptions

#### Technical

The IGCC cases are dual-train gasification systems. Once the syngas is cleaned of acid gases and other contaminants, it is fed to two advanced F-Class combustion turbines (232 MWe gross output each) coupled with two heat recovery steam generators (HRSG) and a single steam turbine to generate roughly 740 MWe

Table 1. Study Matrix

Plant Type	Standard Conditions (psig/°F/°F)	Gas Turbine	Gasifier / Boiler	Acid Gas Removal / CO <sub>2</sub> Separation / Sulfur Recovery	CO <sub>2</sub> Capture (%)
IGCC	1,800/1,050/1,050	F-Class	GEE	Selexol/ - /Claus	-
			CoP	MDEA/ - /Claus	-
			Shell	Sulfinol-M/ - /Claus	-
	1,800/1,000/1,000		GEE	Selexol/Selexol/Claus	90
			CoP	Selexol/Selexol/Claus	90
			Shell	Selexol/Selexol/Claus	90
PC	2,400/1,050/1,050	-	Subcritical	Wet flue gas desulfurization (FGD)/ - /Gypsum	-
				Wet FGD/Econamine/Gypsum	90
	3,500/1,100/1,100		Supercritical	Wet FGD/ - /Gypsum	-
				Wet FGD/Econamine/Gypsum	90
NGCC	2,400/1,050/950	F-Class	Heat recovery steam generators	-	-
				- /Econamine/ -	90

gross plant output (about 625 MWe, net). The CCS cases require a water-gas-shift (WGS) and a two-stage Selexol system to capture the carbon dioxide (CO<sub>2</sub>), as well as compressors to raise the CO<sub>2</sub> to the pipeline requirements of 15.3 MPa (2,215 psia). These CCS systems require a significant amount of extraction steam and auxiliary power, which reduces the output of the steam turbine and reduces the net plant power to about 520 MWe. Because the IGCC system is constrained by the discrete F-Class turbine size, the system cannot be scaled to increase the net output to match that of the cases without CCS.

All four PC cases employ a one-on-one configuration comprising a state-of-the-art PC steam generator and steam turbine. The boiler is a dry-bottom, wall-fired unit that employs low-nitrogen oxides (NO<sub>x</sub>) burners with over-fire air and selective catalytic reduction for NO<sub>x</sub> control, a wet-limestone, forced-oxidation scrubber for sulfur dioxide (SO<sub>2</sub>) and mercury (Hg) control, and a fabric filter for particulate matter (PM) control. In the cases with CCS, the PC plant is equipped with the Econamine FG Plus™ process. The coal feed rate is increased in the CCS cases to increase the gross steam turbine output and account for the higher auxiliary load of carbon capture and compression. The ability of the boiler and steam turbine industry to match unit size to a custom specification has been commercially demonstrated, enabling a common net output of 550 MWe for the PC cases in this study.

Both the IGCC and PC cases utilize Illinois No. 6 bituminous coal. An analysis of the coal used in the study is provided in Table 2.

The NGCC cases use two F-Class turbines, each generating a gross 181 MWe. The two turbines are coupled with two HRSGs and one steam turbine generator in a multi-shaft 2x2x1 configuration. For the CCS cases, CO<sub>2</sub> is removed in an Econamine FG Plus™ process that imposes a significant auxiliary power load on the system and requires significant extraction steam, reducing the steam turbine power output. Similar to the IGCC cases, the NGCC cases are constrained by the combustion turbine size. The NGCC cases have a total net power output of 555 MWe without CCS and 474 MWe with CCS.

In all CCS cases, the compressed CO<sub>2</sub> is transported 50 miles via pipeline to a geologic sequestration field for injection into a saline aquifer. In addition to transport and storage, the CO<sub>2</sub> is monitored for 80-years.

## Environmental

The environmental approach for the study was to choose environmental targets for each technology that meet or exceed regulatory requirements. The IGCC targets were chosen to match the design basis of the Electric Power Research Institute for their *CoalFleet for Tomorrow Initiative*. Best Available Control Technology was applied to each of the PC and NGCC cases, and the resulting emissions were compared to 2006 New Source Performance Standards limits and recent permit averages. The environmental targets are presented in Table 3.

**Table 2. Coal Analysis**

Rank	Bituminous	
Seam	Illinois No. 6 (Herrin)	
Source	Old Ben Mine	
Proximate Analysis (weight %) <sup>1</sup>		
	As Received	Dry
Moisture	11.12	0.00
Ash	9.70	10.91
Volatile matter	34.99	39.37
Fixed carbon	44.19	49.72
Total	100.00	100.00
Sulfur	2.51	2.82
Higher heating value, Btu/lb	11,666	13,126
Lower heating value, Btu/lb	11,252	12,712

<sup>1</sup>The above proximate analysis assumes sulfur as a volatile matter.

**Table 3. Environmental Targets**

Pollutant	IGCC	PC	NGCC
SO <sub>2</sub>	0.0128 lb/MMBtu	0.085 lb/MMBtu	Negligible
NO <sub>x</sub>	15 ppmvd @ 15% Oxygen	0.07 lb/MMBtu	2.5 ppmvd @ 15% Oxygen
PM (filterable)	0.0071 lb/MMBtu	0.013 lb/MMBtu	Negligible
Hg	> 90% capture	1.14 lb/TBtu	N/A

## Economic

The Total Overnight Cost (TOC) for each plant was calculated by adding owner’s costs to the Total Plant Cost (TPC). The TPC for each technology was determined through a combination of vendor quotes, scaled estimates from previous design/build projects, or a combination of the two. TPC includes all equipment (complete with initial chemical and catalyst loadings), materials, labor (direct and indirect), engineering and construction management, and contingencies (process and project). Escalation and interest on debt during the capital expenditure period were estimated and added to the TOC to provide the Total As-spent Cost (TASC).

The cost estimates carry an accuracy of -15 percent / +30 percent, consistent with a “feasibility study” level of design engineering applied to the various cases in this study. The value of the study lies not in the absolute accuracy of the individual case results but in the fact that all cases were evaluated under the same set of technical and economic assumptions. This consistency of approach allows meaningful comparisons among the cases evaluated.

Table 4 lists the major economic assumptions. In this study, dual trains were used only when equipment capacity required an additional train, and no redundancy was employed other than normal sparing of rotating equipment.

This study assumes that each new plant would be dispatched any time it is available and would be capable of generating maximum capacity when online. Therefore, capacity factor (CF) is assumed to equal availability. The CF is 80 percent for IGCC cases and 85 percent for both PC and NGCC cases.

**Table 4. Major Economic Assumptions**

Startup date (natural gas / coal)	2010/2012
Cost year (U.S. dollars)	2007
Coal cost (\$/MMBtu)	1.64
Natural gas cost (\$/MMBtu)	6.55
Capacity factor (%)	
IGCC	80
PC/NGCC	85
Capital charge factor (%):	
High risk (5-Yr IGCC PC w/CO <sub>2</sub> capture) / (3-Yr NGCC w/CO <sub>2</sub> capture)	12.43 / 11.11
Low risk (5-Yr PC w/o CO <sub>2</sub> capture) / (3-Yr NGCC w/o CO <sub>2</sub> capture)	11.65 / 10.48
Plant life (years)	30

**Figure I. Plant Efficiency**

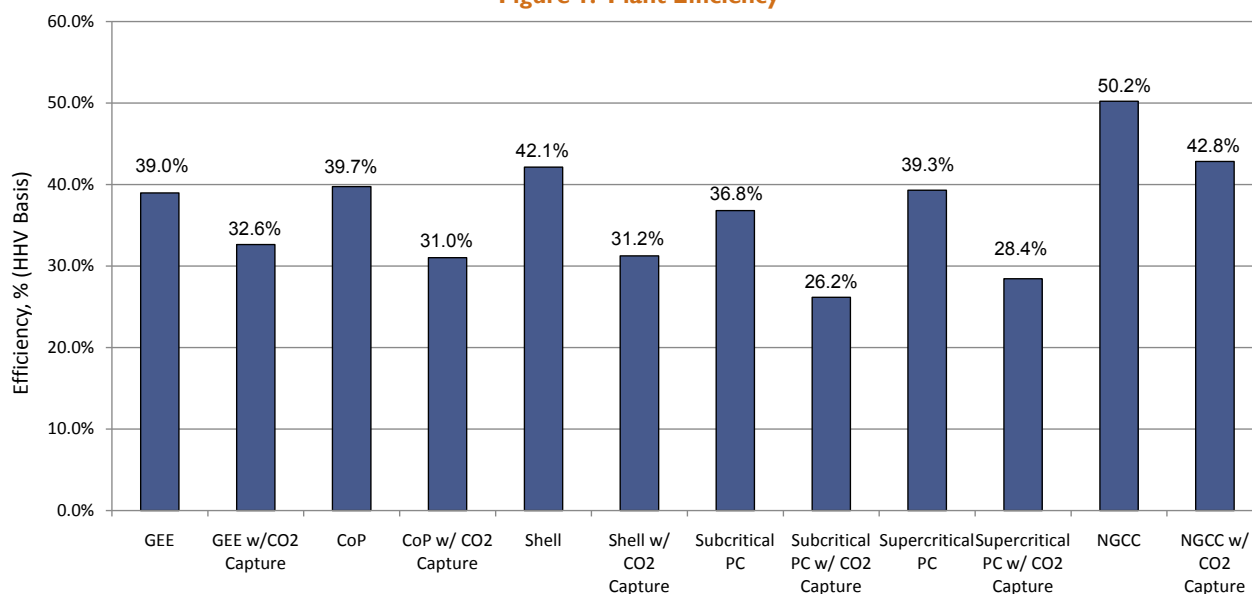

## Results

### Technical

For cases without CCS, the energy efficiency of NGCC is about 50 percent (higher heating value, [HHV] basis); followed by supercritical PC and IGCC, both about 40 percent (HHV basis); and subcritical PC, with an efficiency of about 37 percent (HHV basis). Figure 1 shows the energy efficiency of each technology case.

With CCS, the energy penalty is 11 percentage points for PC plants, 7 percentage points for NGCC, and 6-11 percentage points for IGCC. Even with CCS, NGCC still maintains the highest efficiency of the plants evaluated at over 40 percent (HHV basis). The significant energy penalty for the PC plants reduces the efficiency to about 27 percent (HHV basis). IGCC has an efficiency advantage over PC in the CCS cases primarily because the CO<sub>2</sub> is more concentrated in IGCC syngas than in PC flue gas, thus requiring less energy to capture. The efficiency of the IGCC plants with CCS is about 32 percent (HHV basis).

### Environmental

All cases meet or exceed the environmental requirements set forth in the study design basis. The NGCC systems are the cleanest types of fossil power plants due to the low sulfur content and lower carbon-to-hydrogen ratio of the methane fuel. IGCC plants are the cleanest coal-based systems, with significantly lower levels of criteria pollutants than the PC plants. Figure 2 compares the results for these pollutant emissions for the various technology cases.

Figure 2. SO<sub>2</sub>, NO<sub>x</sub>, and PM Emissions

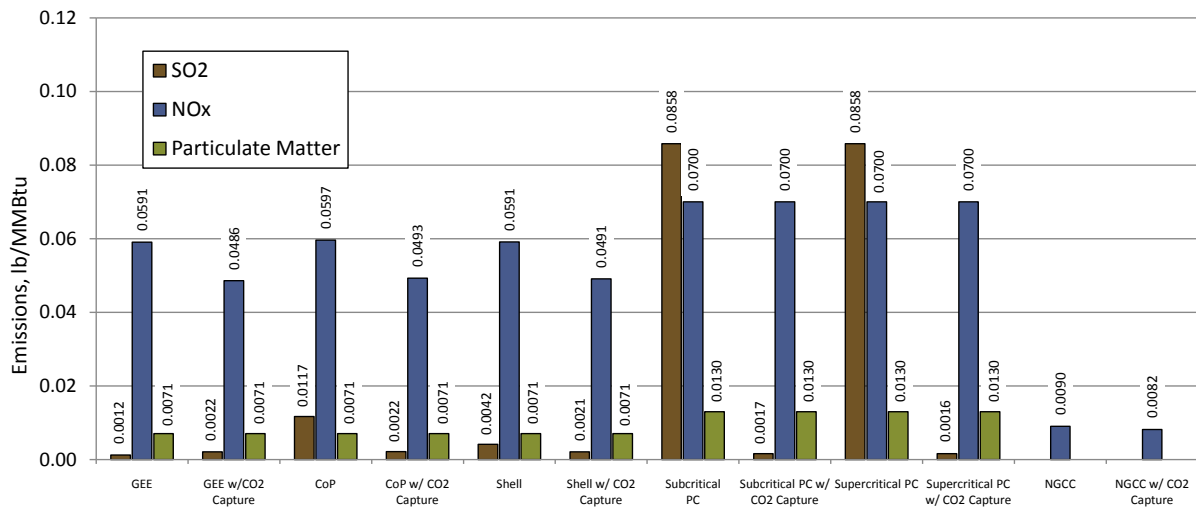

All CCS cases were required to remove 90 percent of the carbon present in the syngas. NGCC plants produce 40 percent less CO<sub>2</sub> than the coal-based systems. The uncontrolled coal-based systems emitted between 1,595 and 1,900 lb/MWh<sub>net</sub> of CO<sub>2</sub>, but with CCS, emissions were reduced to between 200 and 266 lb/MWh<sub>net</sub>. Figure 3 compares the results for CO<sub>2</sub> emissions for the various technology cases.

All cases were required to control Hg emissions. The environmental target for Hg removal is greater than 90 percent capture for IGCC plants and an emission rate of 1.14 lb/TBtu for PC plants. Figure 4 depicts the Hg emissions results for each case.

Water consumption among the plants without CCS is lowest in the NGCC cases. The IGCC plants use about 70 percent more than the NGCC cases, and the PC cases use more than twice the amount of water.

# Overview — Bituminous Coal & Natural Gas to Electricity

Figure 3. CO<sub>2</sub> Emissions

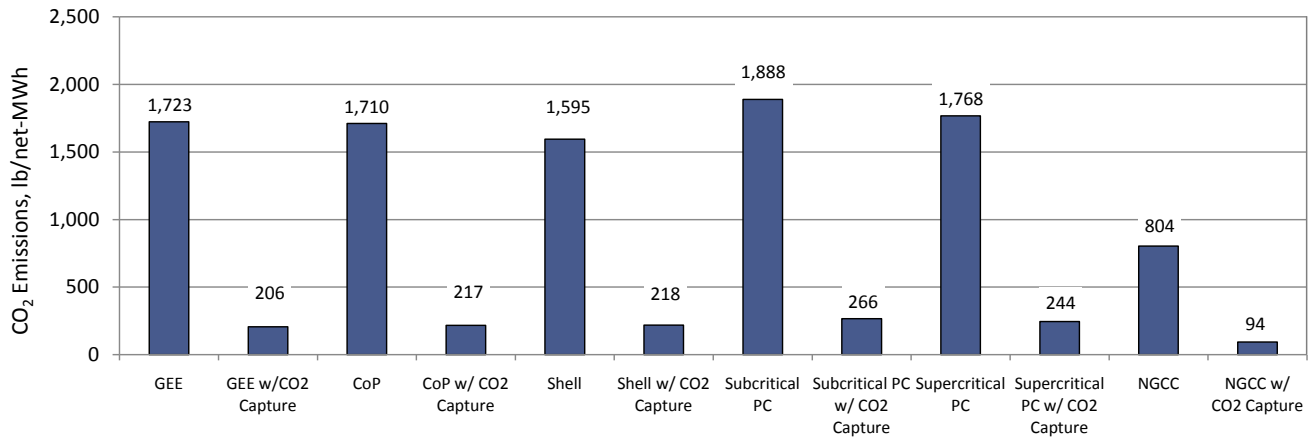

Figure 4. Mercury Emissions

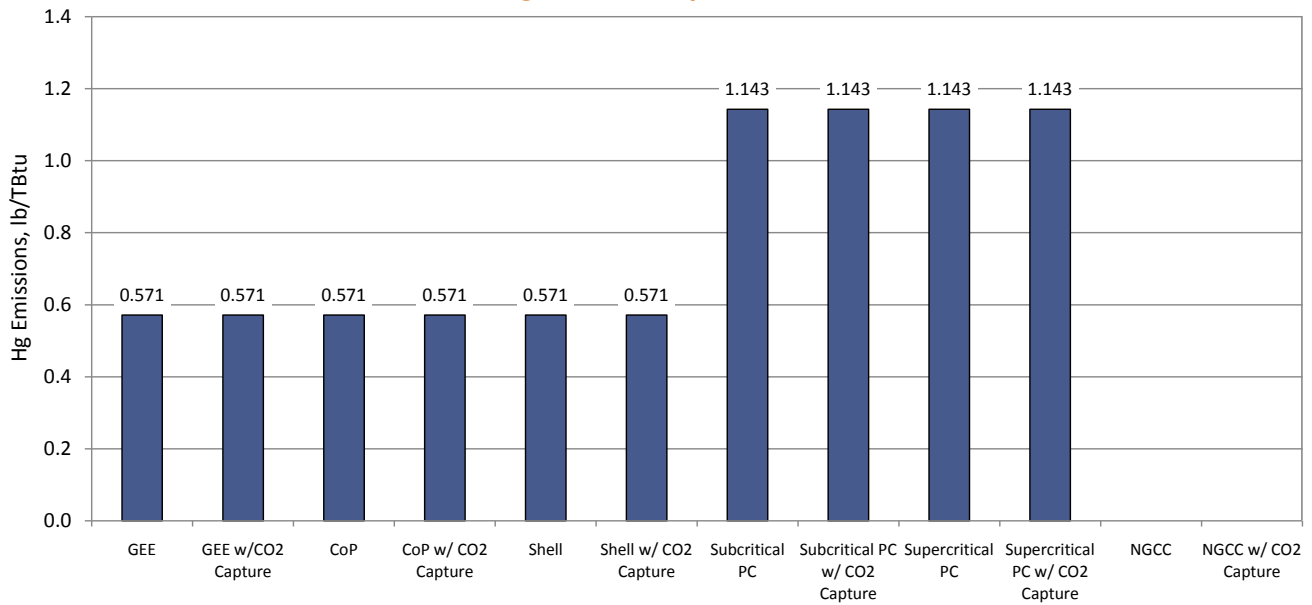
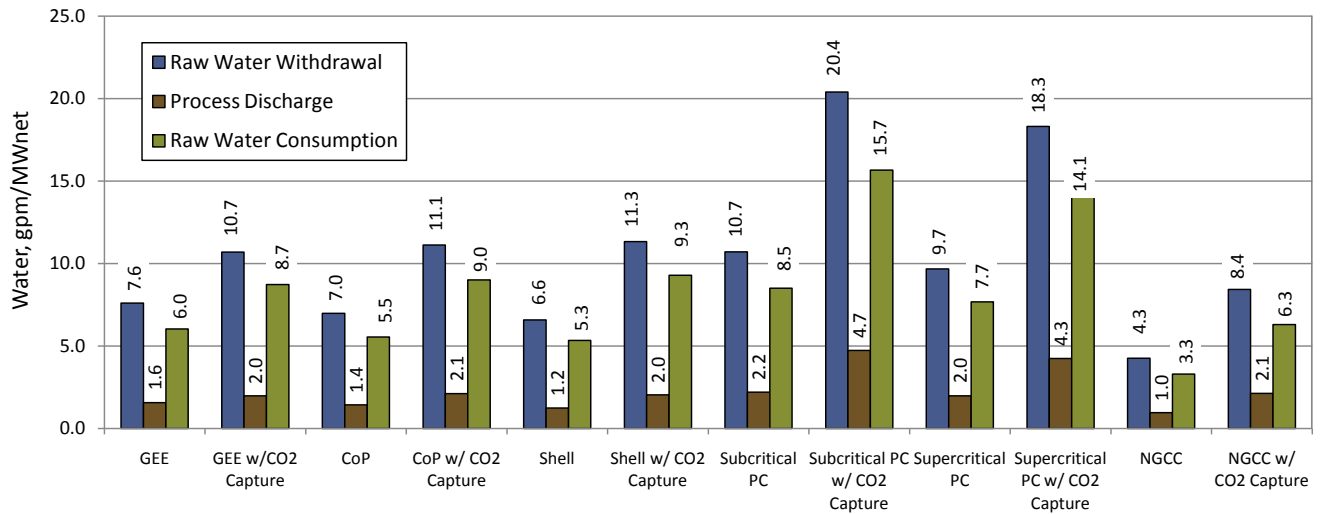

Figure 5. Plant Raw Water Usage



CCS cases use more water, in large part due to solvent regeneration for the CO<sub>2</sub> capture process. Water consumption for IGCC cases is about 40 percent higher than NGCC with CCS, whereas the PC case with CCS plants requires about two and one half times more water. Figure 5 shows the respective water consumption rates for each technology case.

## Economic

The coal-based plants have a much higher TOC than NGCC, both with and without CCS. For IGCC without CCS, the TOC is about \$2,500/kWe, varying somewhat based on the gasifier type. This is about 20 percent higher than the TOC for a PC supercritical plant without CCS, which is about \$2,024/kWe.

With CCS, the TOC for NGCC and PC plants (\$/kW) increases by about 108 and 79 percent respectively. The TOC for the IGCC plant increases by around 42 percent. Among the non-capture cases, NGCC has the lowest TOC at \$718/kW. Figure 6 shows the TOC for each technology case.

Figure 6. Plant Capital Requirements

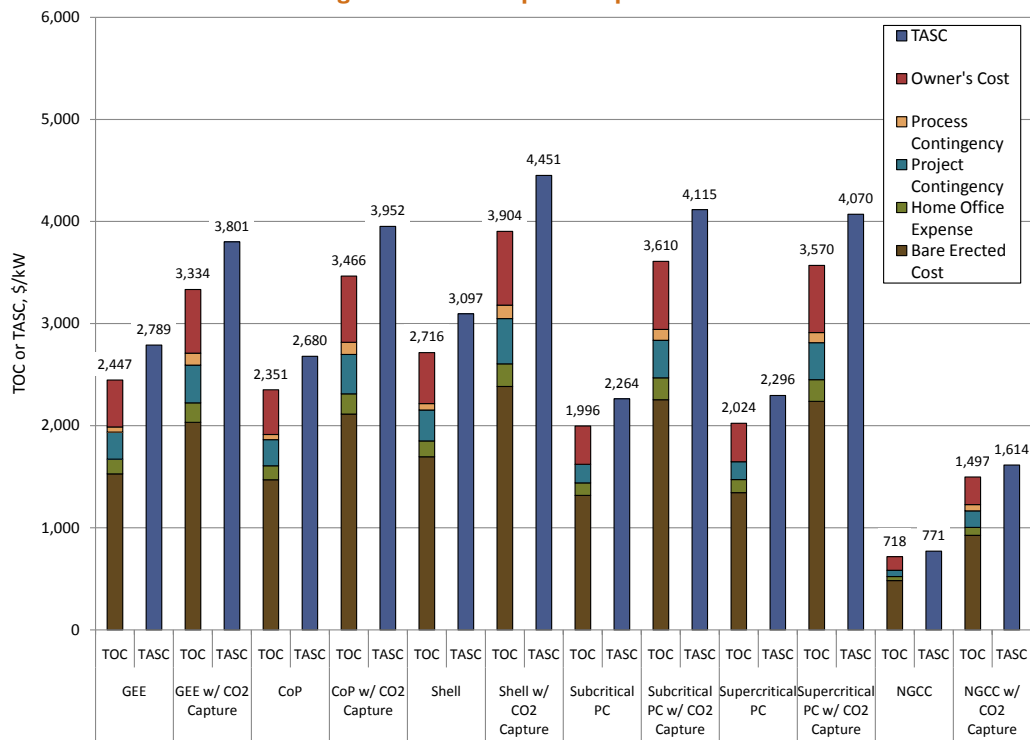

Cost-of-electricity (COE), which accounts for both efficiency and capital cost, is expressed in mills/kWh (same numerically as \$/MWh). The electricity cost for cases without CCS is about 59 mills/kWh for PC and NGCC, and an average of 77.2 mills/kWh for IGCC.

With CCS, IGCC and PC plants have comparable COEs. Figure 7 breaks out the COE costs for each technology case.

The cost of CO<sub>2</sub> avoided was calculated for each CCS case and is shown in Figure 8. CO<sub>2</sub> avoided costs for IGCC plants using analogous non-capture plants as reference are substantially less than for PC and NGCC because the IGCC CO<sub>2</sub> removal is accomplished prior to combustion and at elevated pressure using physical absorption.



# Overview — Bituminous Coal & Natural Gas to Electricity

Figure 9 illustrates that at near 80 percent CF, the COE for PC cases is less than the COE for NGCC cases. With increased CF, the gap in COE between IGCC cases and other technologies narrows.

The COE sensitivity to fuel costs for the cases with and without CCS is shown in Figure 10. The blue line is the COE of NGCC without CCS as a function of natural gas cost. The green line is the COE of NGCC with CCS as a function of natural gas cost. The points on the lines represent the natural gas cost that would be required to

Figure 7. First year Cost-of-Electricity

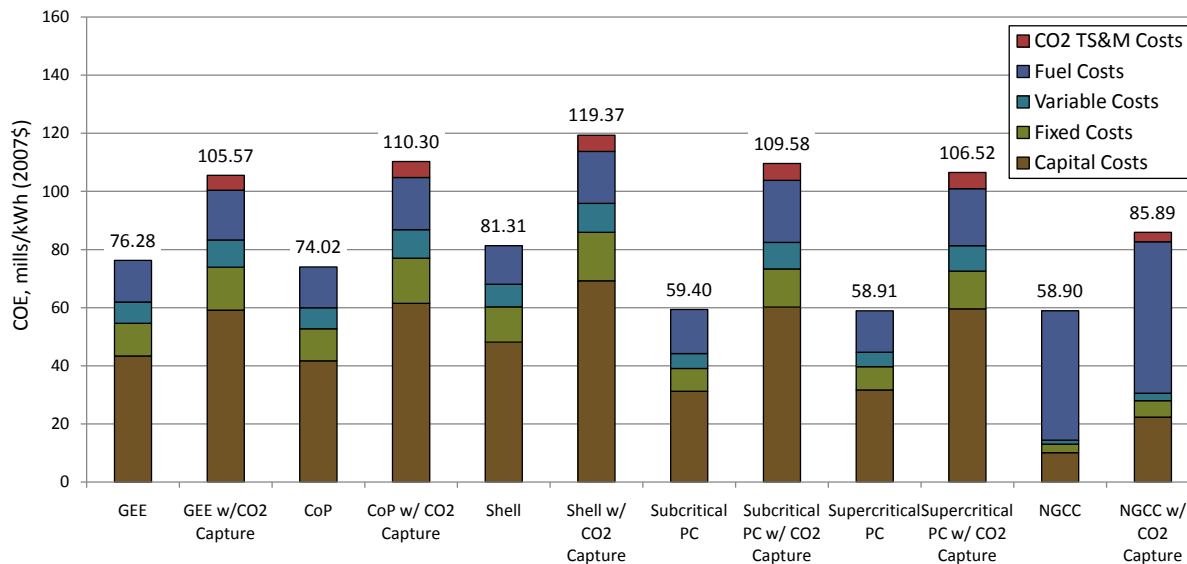

Figure 8. Cost of CO<sub>2</sub> Avoided

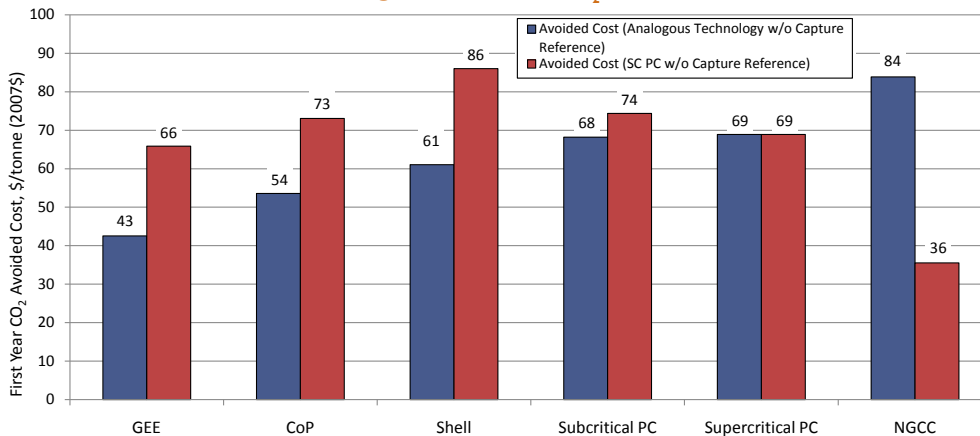
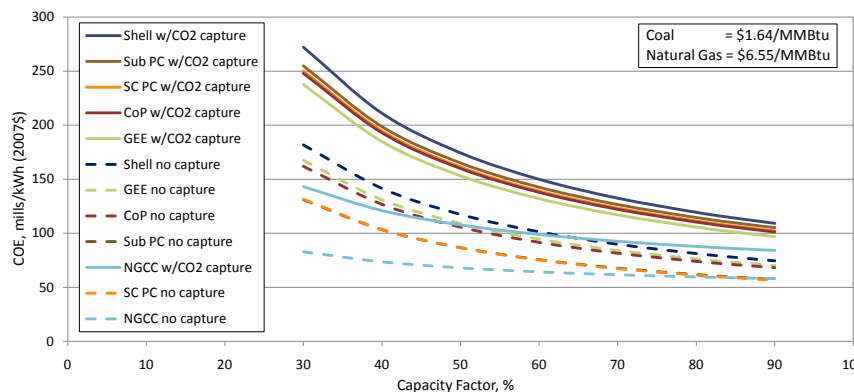

Figure 9. COE Sensitivity to Capacity Factor



# Overview — Bituminous Coal & Natural Gas to Electricity

make the COE of NGCC equal to the respective PC or IGCC technologies at a given coal cost. The coal prices shown (\$1.35, \$1.80, and \$2.25/MMBtu) represent the baseline cost and a range of  $\pm 25$  percent around the baseline.

Figure 10 shows that the COE of IGCC without CCS at a coal price of \$1.23/MMBtu is greater than PC at a coal price of \$2.05/MMBtu, due to the higher capital cost of IGCC and its relative insensitivity to fuel price. With CCS, the COE of NGCC is less than IGCC and PC at the baseline natural gas price of \$6.55/MMBtu.

Figure 10. COE Sensitivity to Fuel Costs

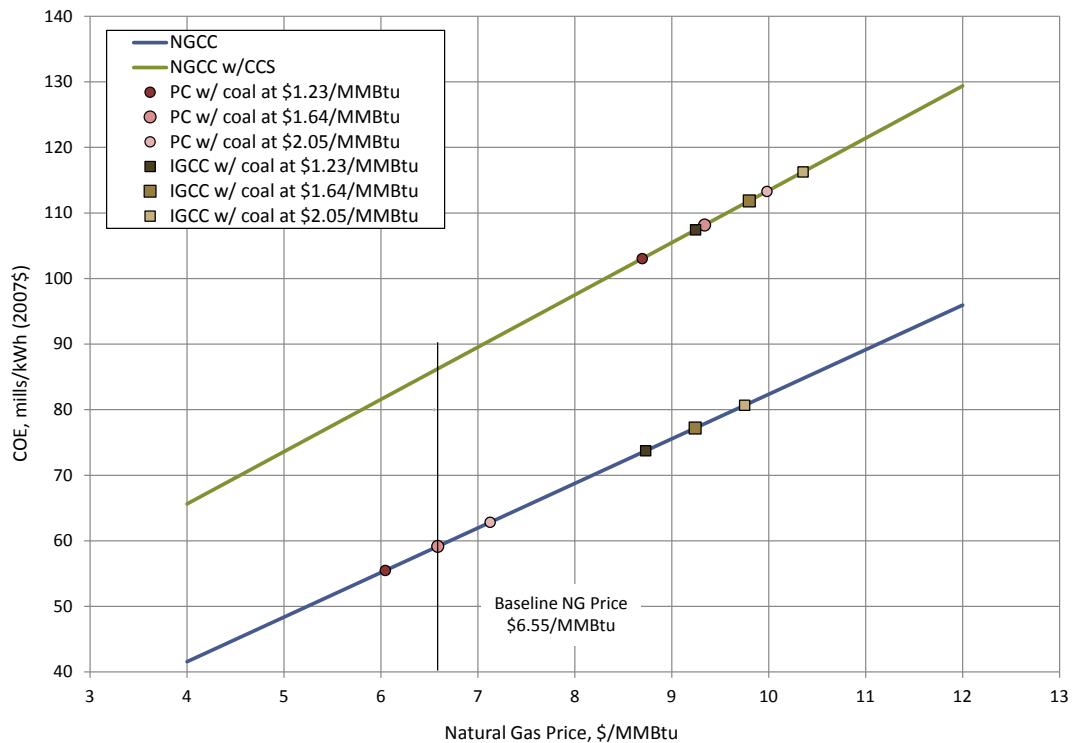

## Contacts

**James Black**  
General Engineer  
National Energy Technology Laboratory  
626 Cochran Mill Road  
P.O. Box 10940  
Pittsburgh, PA 15236  
412-386-5458  
james.black@netl.doe.gov

**Larry Rath**  
Director of Performance Division  
National Energy Technology Laboratory  
626 Cochran Mill Road  
P.O. Box 10940  
Pittsburgh, PA 15236  
412-386-6871  
larry.rath@netl.doe.gov

## References

Cost and Performance Baseline for Fossil Energy Plants, Vol. I. (2010, November). Pittsburgh, PA. DOE/NETL-2010/1397.

CoalFleet User Design Basis Specification for Coal-Based Integrated Gasification Combined Cycle (IGCC) Power Plants, (2009). EPRI, Palo Alto, CA. 1017501.

# IGCC Plants With and Without Carbon Capture and Sequestration

## Technology Overview

Six Integrated Gasification Combined-Cycle (IGCC) power plant configurations operating on bituminous coal were evaluated, and the results are presented in this summary sheet. All cases were analyzed on the same basis, using a consistent set of assumptions and analytical tools. Each gasifier type was assessed with and without carbon capture and sequestration (CCS). The individual configurations are as follows:

- GE Energy (GEE) IGCC plant
- GEE IGCC plant with CCS
- ConocoPhillips (CoP) E-Gas™ IGCC plant
- CoP IGCC plant with CCS
- Shell IGCC plant
- Shell IGCC plant with CCS

Each IGCC design is based on a market-ready technology that is assumed to be commercially available in time to support a 2012 startup date. In cases in which equipment or processes have little or no commercial operating experience, a process contingency is added to the cost analysis. The IGCC plants are built at a greenfield site in the midwestern United States and are assumed to operate at 80 percent capacity factor (CF) without sparing of major train components. All designs employ state-of-the-art gasifier technology. The primary fuel is an Illinois No. 6 bituminous coal with a higher heating value (HHV) of 11,666 Btu/lb. Syngas generated in the oxygen (O<sub>2</sub>)-blown gasifier is cooled and cleaned prior to being fed to two advanced F-Class combustion turbines. The Brayton cycle is combined with two heat recovery steam generators (HRSG) and a steam turbine for Rankine cycle power generation. For the CCS cases, a water-gas-shift (WGS) reactor converts carbon monoxide (CO) to carbon dioxide (CO<sub>2</sub>), and a two-stage Selexol Acid Gas Removal (AGR) unit separates the hydrogen sulfide (H<sub>2</sub>S) and CO<sub>2</sub>. After compression, the CO<sub>2</sub> is transported for storage and monitoring.

See Figure 1 for a generic block flow diagram of an IGCC plant. The orange blocks in the figure represent the unit operations added to the configuration for CCS cases.

Figure 1. IGCC Power Plant

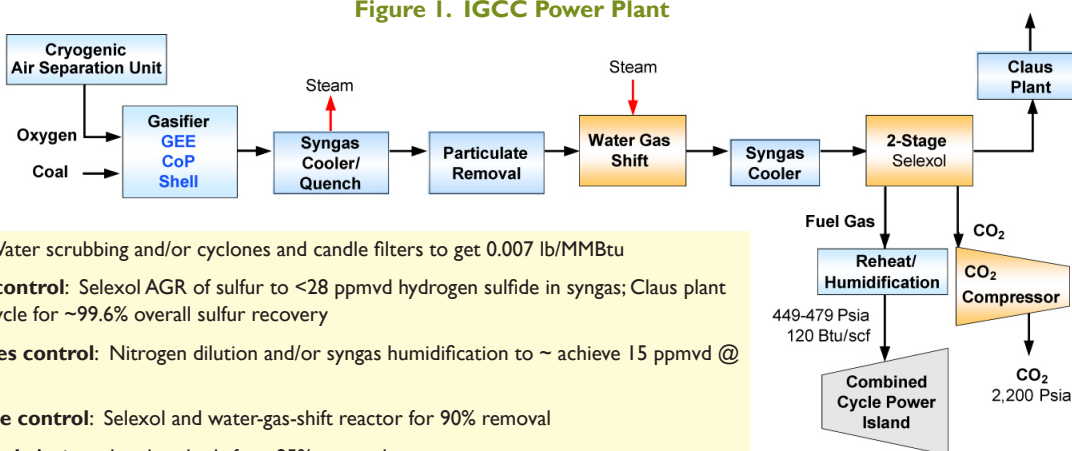

- PM control:** Water scrubbing and/or cyclones and candle filters to get 0.007 lb/MMBtu
- Sulfur oxides control:** Selexol AGR of sulfur to <28 ppmvd hydrogen sulfide in syngas; Claus plant with tail gas recycle for ~99.6% overall sulfur recovery
- Nitrogen oxides control:** Nitrogen dilution and/or syngas humidification to ~ achieve 15 ppmvd @ 15% oxygen
- Carbon dioxide control:** Selexol and water-gas-shift reactor for 90% removal
- Mercury control:** Activated carbon beds for ~95% removal
- Advanced F-Class turbine:** 232 MWe
- Steam conditions:** 1,800 psig/1,050°F (w/o CCS); 1,800 psig/1,000°F (with CCS)

Orange blocks indicate unit operations added for CCS Case.

Note: Diagram is provided for general reference of major flows only. For complete flow information, please refer to the final report.

## Technical Description

Oxygen-blown, dual-gasifier trains are supplied with Illinois No. 6 bituminous coal. Cryogenic air separation units supply 95 mole percent oxygen to the gasifiers. After being cleaned of particulate matter (PM), mercury (Hg), and sulfur compounds, the syngas is fed to two combustion turbines. The combustion turbines are based on an advanced F-Class design that generates 232 MWe on syngas. With two combustion turbines, the combined gross gas turbine output is 464 MWe.

Nitrogen dilution is used to the maximum extent possible in all cases, and syngas humidification and steam injection are used only if necessary to achieve a syngas lower heating value (LHV) of approximately 120 Btu/scf. The Brayton cycle is integrated with a conventional subcritical steam Rankine cycle consisting of two HRSGs and a steam turbine, operating at 12.4 MPa/566°C/566°C (1,800 psig/1,050°F/1,050°F) in cases without CCS. The two cycles are integrated by use of the combustion turbine exhaust heat for generation of steam in the HRSGs, by feedwater heating in the HRSGs, and by heat recovery from the IGCC process. Recirculating evaporative cooling systems are used for cycle heat rejection. The average efficiency of the cases without CCS is 40 percent (HHV basis) for a plant with a net plant output of about 625 MWe.

The CCS cases require a significant amount of auxiliary power and extraction steam for the CCS process, which reduces the output of the steam turbine along with a reduction in steam conditions to 12.4 MPa/538 °C/538°C (1,800 psig/1,000°F/1,000°F). The lower main and reheat steam temperature is due to reduced turbine firing temperature. Although the reduced firing temperature allows for more reliable operation with a high-hydrogen content fuel, it also results in a lower turbine exhaust temperature. This results in a lower net plant output for the CCS cases of about 518 MWe, for an average net plant efficiency of 32 percent (HHV basis).

The nominal 90 percent CO<sub>2</sub> reduction is accomplished by adding sour-gas-shift (SGS) reactors to convert CO to CO<sub>2</sub> and using a two-stage Selexol process with a second stage CO<sub>2</sub> removal efficiency of up to 95 percent.

Once captured, the CO<sub>2</sub> is dried and compressed to 15.3 MPa (2,215 psia). The compressed CO<sub>2</sub> is transported via pipeline to a geologic sequestration field for injection into a saline aquifer, which is located within 50 miles of the plant. Therefore, CO<sub>2</sub> transport, storage, and monitoring (TS&M) costs are included in the analyses.

### Fuel Analysis and Costs

All IGCC coal-fired cases were modeled using Illinois No. 6 coal, characterized by the proximate analysis shown in Table 1.

A final delivered cost of \$1.64/MMBtu (June 2007 dollars) was determined from the Energy Information Administration AEO2008 for an eastern interior high-sulfur bituminous coal.

### Environmental Design Basis

The environmental approach for this study was to evaluate each of the IGCC cases on the same regulatory design basis. The environmental specifications for a greenfield IGCC plant are based on the Electric Power Research Institute (EPRI) *CoalFleet User Design Basis for Coal-Based IGCC Plants* specification. Table 2 provides details of the environmental design basis for IGCC plants built at a midwestern location.

Table 1. Fuel Analysis

Rank	Bituminous	
Seam	Illinois No. 6 (Herrin)	
Source	Old Ben Mine	
Proximate Analysis (weight %) <sup>1</sup>		
	As Received	Dry
Moisture	11.12	0.00
Ash	9.70	10.91
Volatile matter	34.99	39.37
Fixed carbon	44.19	49.72
<b>Total</b>	<b>100.00</b>	<b>100.00</b>
Sulfur	2.51	2.82
Higher heating value, Btu/lb	11,666	13,126
Lower heating value, Btu/lb	11,252	12,712

<sup>1</sup>The above proximate analysis assumes sulfur as a volatile matter.

The emission controls assumed for each of the six IGCC cases are as follows:

- Selexol, Sulfinol-M, or refrigerated methyldiethanolamine AGR in combination with a Claus plant were used for sulfur dioxide (SO<sub>2</sub>) control in the GEE, Shell, and CoP cases without CCS, respectively
- A two-stage Selexol process was used for AGR and CO<sub>2</sub> control in all CCS cases
- Nitrogen dilution was used for nitrogen oxides (NO<sub>x</sub>) control to the maximum extent possible, and humidification and steam injection were used to obtain the required syngas heating value, if required
- Water scrubbing and/or cyclones and candle filters were used for PM control
- Activated carbon beds were used for Hg removal

**Table 2. Environmental Targets**

Pollutant	IGCC
SO <sub>2</sub>	0.0128 lb/MMBtu
NO <sub>x</sub>	15 ppmvd @ 15% Oxygen
PM (filterable)	0.0071 lb/MMBtu
Hg	>90% capture

## Major Economic and Financial Assumptions

For the IGCC cases, estimates of capital and operations costs were developed for each plant based on adjusted vendor-furnished and actual cost data from recent design/build projects. These costs were used to calculate a first year cost-of-electricity (COE) based on the power plant costs and assumed financing structure. Listed in Table 3 are the major economic and financial assumptions for the IGCC cases.

Project contingencies were added to each of the cases to cover project uncertainty and the cost of any additional equipment that could result from detailed design. The project contingencies represent costs that are expected to occur. Project contingency was about 10 percent for the IGCC cases without CCS and about 11 percent for the IGCC cases with CCS.

Process contingency is intended to compensate for uncertainties arising as a result of the state of technology development. Process contingencies have been applied to the estimates as follows:

- Slurry Prep and Feed – 5 percent on GE IGCC cases
- Gasifiers and Syngas Coolers – 15 percent on all IGCC cases
- Two Stage Selexol – 20 percent on all IGCC cases with CCS
- Mercury Removal – 5 percent on all IGCC cases
- Combustion Turbine Generator – 5 percent on all IGCC cases without CCS; 10 percent on all IGCC cases with CCS
- Instrumentation and Controls – 5 percent on all IGCC cases

**Table 3. Major Economic and Financial Assumptions for IGCC Cases**

Major Economic Assumptions	
Capacity factor	80%
Costs per year, constant U.S. dollars	2007 (January)
Illinois No. 6 coal delivered cost	\$1.64/MMBtu
Construction period	5 years
Plant startup date	2012 (January)
Major Financial Assumptions	
Depreciation	20 years
Federal income tax	34%
State income tax	6%
After tax weighted cost of capital	8.13%
Capital structure:	
Common equity	55% (Cost = 12%)
Debt	45% (Cost = 11%)
Capital charge factor	12.4%

This study assumes that each new plant would be dispatched any time it is available and would be capable of generating maximum capacity when online. Therefore, CF is assumed to equal availability and is 80 percent for IGCC cases.

For the IGCC cases that feature CCS, capital and operating costs were estimated for transporting CO<sub>2</sub> to an underground storage field, associated storage in a saline aquifer, and monitoring beyond the expected life of the plant.

## Results

An analysis of the six IGCC cases is presented in the following sections.

**Figure 2. Comparison of TPC for the Six IGCC Cases**

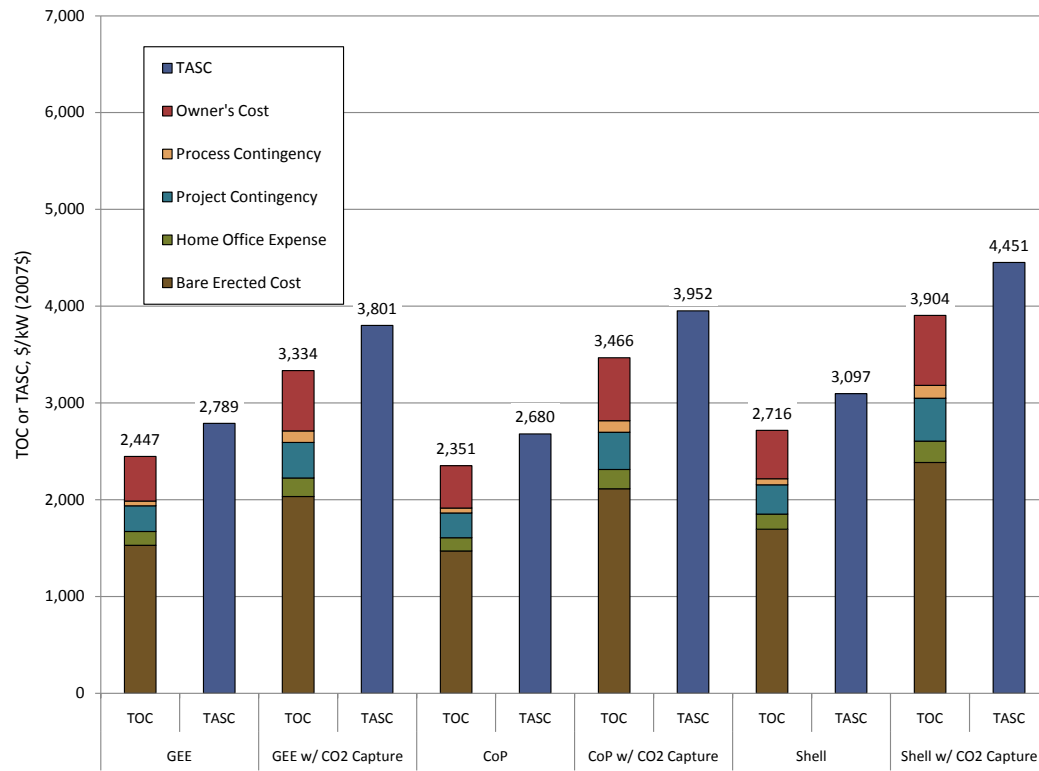

### Efficiency

The net plant efficiencies for the six IGCC cases are compared in Figure 3. This analysis indicates that, in the cases without CCS, the Shell plant efficiency of 42.1 percent is over 3 percentage points higher than the GEE case. With CCS cases, the efficiency penalty is a 6.4 to 10.9 percentage point drop in all IGCC plant cases, resulting in an average efficiency of roughly 32 percent.

### Economic Analysis

The COE is a measurement of the coal-to-busbar cost of power, and includes the Total Overnight Cost (TOC), fixed and variable operating costs, and fuel costs. The calculated cost of TS&M for CO<sub>2</sub> adds an average of 4 mills/kWh to the COE.

The IGCC plants generate power at a COE of about 77 mills/kWh at a CF of 80 percent. When CCS is included, the increased Total Plant Cost (TPC) and reduced efficiency result in a higher COE of roughly 112 mills/kWh.

TOC for each of the six IGCC cases is compared in Figure 2. TOC adds owner's costs to the TPC, which includes all equipment (complete with initial chemical and catalyst loadings), materials, labor (direct and indirect),

**Figure 3. Comparison of Net Plant Efficiency for the Six IGCC Cases**

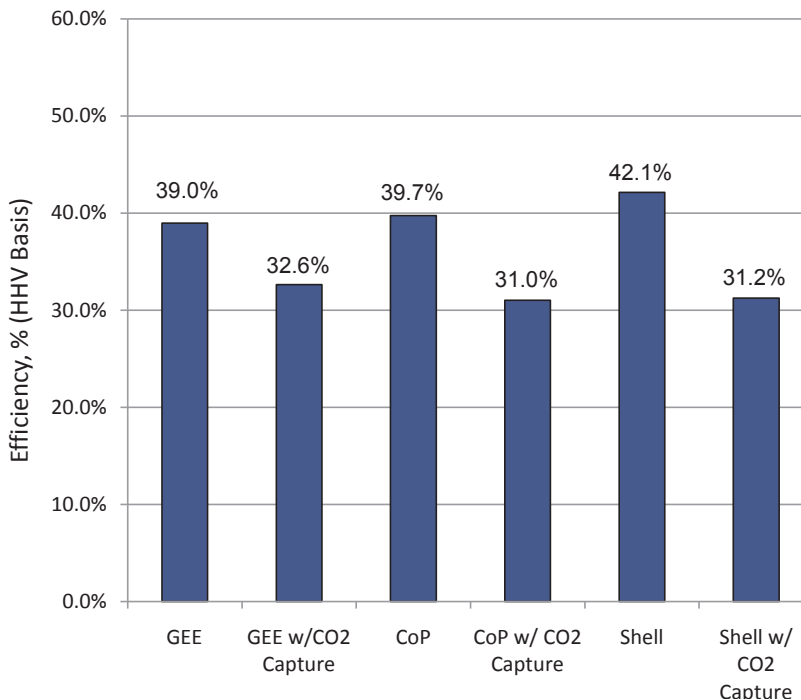

**Figure 4. Comparison of Cost-of-Electricity for the Six IGCC Cases**

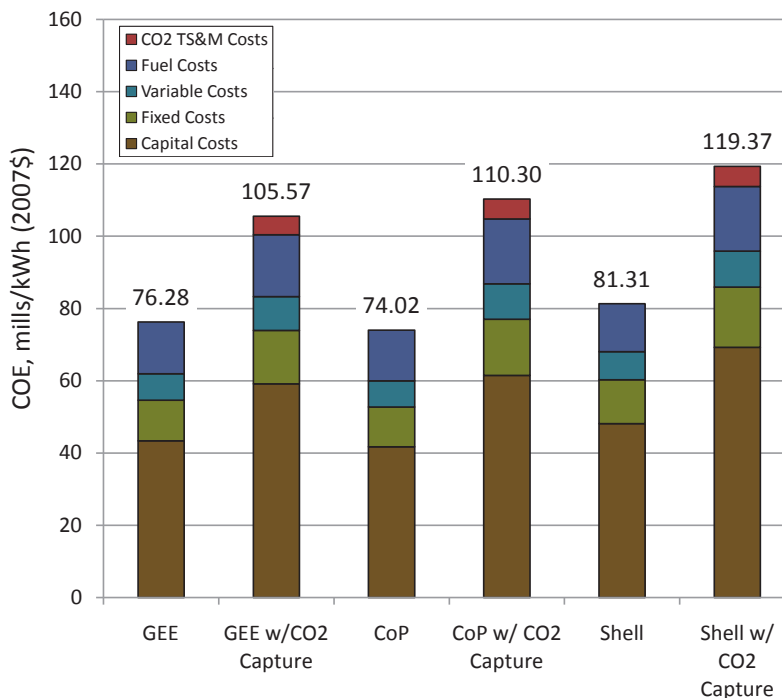

engineering and construction management, and contingencies (process and project). Interest during construction and escalation during construction are not included as owner’s costs but are factored into the COE and are included in Total As-spent Cost (TASC).

The results of the analysis indicate that the Shell IGCC costs about \$365/kWe more than the CoP IGCC without CCS. With CCS, the TOC increases by roughly 36–47 percent for the range of IGCC cases, resulting in a spread of TOC from \$3,334/kWe to \$3,904/kWe.

## Environmental Impacts

Table 4 indicates that the emissions from all six IGCC plants evaluated meet or exceed EPRI's *CoalFleet User Design Basis for Coal-Based IGCC Plants* specification. The cost of CO<sub>2</sub> avoided is defined as the difference in the COE between controlled and reference cases, divided by the difference in CO<sub>2</sub> emissions in kg/MWh. Raw water consumption increases by about 58 percent, on a normalized basis, when CCS is added.

**Table 4. Comparative Emissions for the Six IGCC Cases at 80% Capacity Factor**

Pollutant	IGCC					
	GEE		CoP		Shell	
	Without CCS	W/ CCS (90%) Analogous Ref./ Supercritical PC Ref.	Without CCS	W/ CCS (90%) Analogous Ref./ Supercritical PC Ref.	Without CCS	W/ CCS (90%) Analogous Ref./ Supercritical PC Ref.
<b>CO<sub>2</sub></b>						
• million tonnes/year	3.408	0.355	3.398	0.354	3.189	0.345
• lb/MWh <sub>net</sub>	1,723	206	1,710	217	1,595	218
• cost of CO <sub>2</sub> avoided (\$/tonne)	---	43/66	---	54/73	---	61/86
<b>SO<sub>2</sub></b>						
• tonne/year	21	39	200	39	68	37
• lb/MMBtu	0.0012	0.0022	0.0117	0.0022	0.0042	0.0021
<b>NO<sub>x</sub></b>						
• tonne/year	1,023	878	1,017	885	957	847
• lb/MMBtu	0.059	0.049	0.060	0.049	0.059	0.049
<b>PM</b>						
• tonne/year	123	128	121	127	115	123
• lb/MMBtu	0.0071	0.0071	0.0071	0.0071	0.0071	0.0071
<b>Hg</b>						
• tonne/year	0.010	0.010	0.010	0.010	0.009	0.010
• lb/TBtu	0.571	0.571	0.571	0.571	0.571	0.571
<b>Raw water consumption, gpm/MW<sub>net</sub></b>	6.0	8.7	5.5	9.0	5.3	9.3

## Contacts

### James Black

General Engineer  
National Energy Technology Laboratory  
626 Cochrans Mill Road  
P.O. Box 10940  
Pittsburgh, PA 15236  
412-386-5458  
james.black@netl.doe.gov

### Larry Rath

Director of Performance Division  
National Energy Technology Laboratory  
626 Cochrans Mill Road  
P.O. Box 10940  
Pittsburgh, PA 15236  
412-386-6871  
larry.rath@netl.doe.gov

## References

Cost and Performance Baseline for Fossil Energy Plants, Vol. 1. (2010, November). Pittsburgh, PA. DOE/NETL-2010/1397.  
CoalFleet User Design Basis Specification for Coal-Based Integrated Gasification Combined Cycle (IGCC) Power Plants, (2009). EPRI, Palo Alto, CA. 1017501.



# GE Energy IGCC Plant

## Plant Overview

This analysis is based on a 622 MWe (net power output) Integrated Gasification Combined-Cycle (IGCC) plant using GE Energy (GEE) radiant-only gasification technology, located at a greenfield site in the midwestern United States. The radiant-only configuration consists of a radiant synthesis gas cooler followed by a water quench. Two pressurized, slurry-fed, entrained flow gasification trains feed two advanced F-Class combustion turbines. Two heat recovery steam generators (HRSG) and one steam turbine provide additional power. The combination process and heat and mass balance diagram for the GEE IGCC plant is shown in Figure 1. The primary fuel is an Illinois No. 6 bituminous coal with a higher heating value (HHV) of 11,666 Btu/lb. The capacity factor (CF) for the plant is 80 percent without sparing of major train components. A summary of plant performance data for the GEE IGCC plant is presented in Table 1.

Table 1. Plant Performance Summary

Plant Type	GEE IGCC
Carbon capture	No
Net power output (kWe)	622,050
Net plant efficiency (%)	39.0
Primary fuel (type)	Illinois No. 6 coal
COE (mills/kWh) @ 80% CF	76.3
TPC/TOC (\$/kW)	1,987/2,447

Figure 1. Process Flow Diagram GEE IGCC

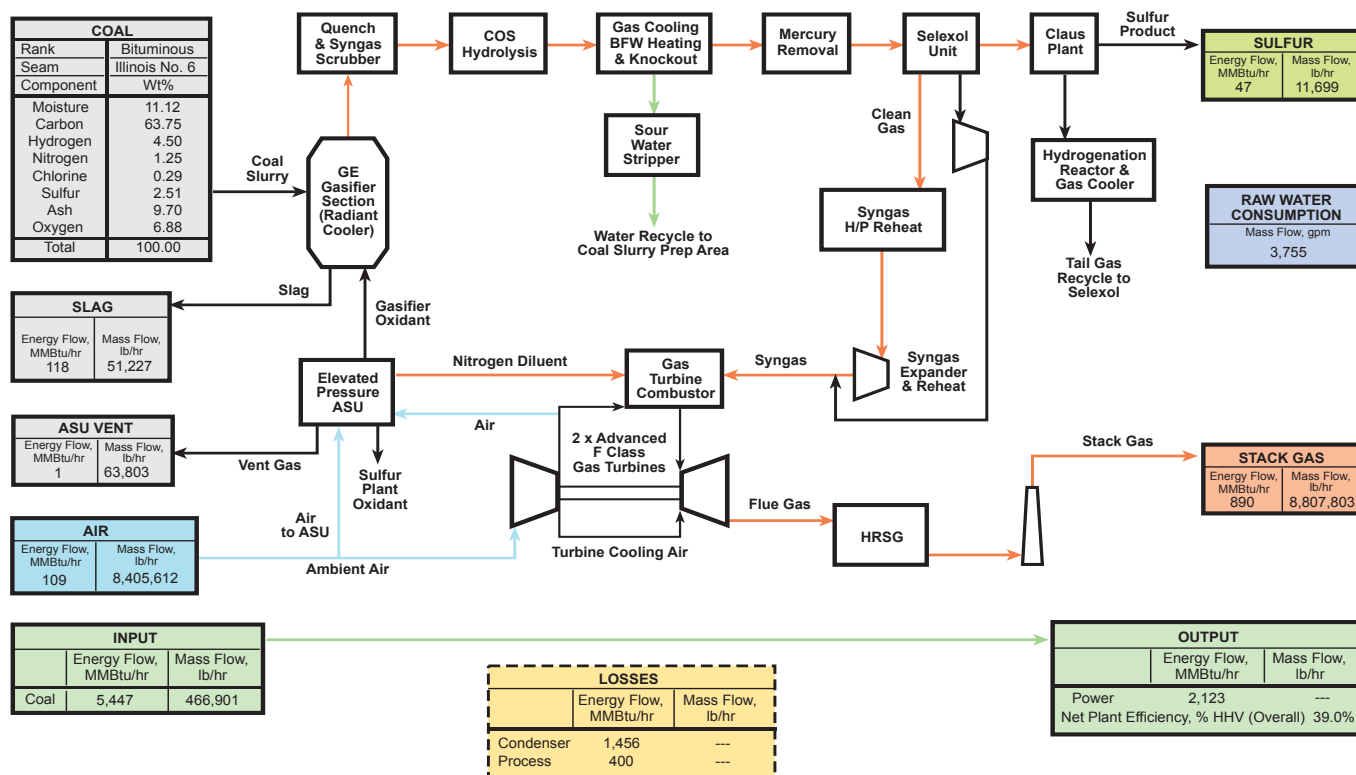

Note: Diagram is provided for general reference of major flows only. For complete flow information, please refer to the final report.

## Technical Description

The plant uses an improved version of the GEE gasification technology (formerly licensed by Chevron Corp. and predecessor company Texaco Inc.), which is currently in operation at the 250 MWe Tampa Electric IGCC plant in Polk County, FL. All technology selected in the plant design is assumed to be available to facilitate a 2012 startup date for a newly constructed plant.

Two gasification trains process a total of 5083 tonnes of coal per day. A slurry (63 percent by weight coal) is transferred from the slurry storage tank to the gasifier with a high-pressure pump. Oxygen (O<sub>2</sub>) is produced in a cryogenic air separation unit. The coal slurry and O<sub>2</sub> react in the gasifier at about 5.6 MPa (815 psia) at a high temperature (in excess of 1,316°C [2,400°F]) to produce syngas. Hot syngas and molten solids from the reactor flow downward into a radiant heat exchanger, where the syngas is cooled to 677°C (1,250°F) and the ash solidifies. Raw syngas continues downward into a quench system where most of the particulate matter (PM) is removed and then into the syngas scrubber where most of the remaining entrained solids are removed along with ammonia. Slag captured by the quench system is recovered in a slag recovery unit. The gas goes through a series of additional gas coolers and cleanup processes, including a carbonyl sulfide hydrolysis reactor, a carbon bed for mercury (Hg) removal, and a Selexol-based acid gas removal (AGR) plant.

A Brayton cycle, fueled by syngas, is used in conjunction with a conventional subcritical steam Rankine cycle for combined-cycle power generation. Compressed nitrogen from the air separation unit is used for syngas dilution, which aids in minimizing the formation of nitrogen oxides (NO<sub>x</sub>) during combustion in the gas turbine burner section. The limiting factor that determines the use of a subcritical steam cycle is the maximum design pressure of 12.4 MPa (1,800 psig) which can be tolerated in the GEE radiant cooler. The two cycles are integrated by generation of steam in the HRSGs, by feedwater heating in the HRSGs, and by heat recovery from the IGCC process (radiant syngas cooler). The HRSG/steam turbine cycle is 12.4 MPa/566°C/566°C (1,800 psig/1,050°F/1,050°F). The plant produces a net output of 622 MWe. The summary of plant electrical generation performance is presented in Table 2. This configuration results in a net plant efficiency of 39.0 percent (HHV basis), or a net heat rate of 8,756 Btu/kWh.

## Environmental Performance

The environmental specifications for a greenfield IGCC plant are based on the Electric Power Research Institute *CoalFleet User Design Basis for Coal-Based IGCC Plants* specification. Low sulfur dioxide (SO<sub>2</sub>) emissions (less than 4 ppmv in the flue gas) are achieved by capture of the sulfur in the Selexol AGR process, which removes over 99 percent of the sulfur in the fuel gas. The resulting hydrogen sulfide-rich regeneration gas from the AGR system is fed to a Claus plant, producing elemental sulfur. Nitrogen oxides emissions are limited by nitrogen dilution in the gas turbine combustor to 15 ppmvd (as nitrogen oxide at 15 percent O<sub>2</sub>). Filterable PM discharge to the atmosphere is limited by the use of the syngas quench in addition to the syngas scrubber and the gas-washing effect of the AGR absorber. Ninety-five percent of the Hg is captured from the syngas by an activated carbon bed.

A summary of the resulting air emissions for the GEE IGCC plant is presented in Table 3.

## Cost Estimation

Estimates of capital and operations costs were developed for each plant based on adjusted vendor-furnished and actual cost data from recent design/build projects. These costs were used to calculate a first year cost-of-

**Table 2. Plant Electrical Generation**

	Electrical Summary
Advanced gas turbine x 2, MWe	464.0
Steam turbine, MWe	276.3
Sweet gas expander, MWe	7.5
Gross power output, MWe	747.8
Auxiliary power requirement, MWe	(125.8)
Net power output, MWe	622

electricity (COE) based on the power plant costs and assumed financing structure. Financial assumptions and a cost summary are shown in Table 4.

Project contingencies were added to each case to cover project uncertainty and the cost of any additional equipment that could result from detailed design. The project contingencies represent costs that are expected to occur. Project contingency was 10.8 percent of the GEE IGCC case Total Plant Cost (TPC).

Process contingency is intended to compensate for uncertainties arising as a result of the state of technology development. Process contingencies represent 2.5 percent of the GEE IGCC case TPC and have been applied to the estimates as follows:

- Slurry Prep and Feed – 5 percent on GE IGCC cases
- Gasifiers and Syngas Coolers – 15 percent on all IGCC cases
- Mercury Removal – 5 percent on all IGCC cases
- Combustion Turbine Generator – 5 percent on all IGCC cases without CCS
- Instrumentation and Controls – 5 percent on all IGCC cases

This study assumes that each new plant would be dispatched any time it is available and would be capable of generating maximum capacity when online. Therefore, CF is assumed to equal availability and is 80 percent for IGCC cases.

The 622 MWe (net) GEE IGCC plant was projected to have a Total Overnight Cost (TOC) of \$2,447/kWe, resulting in a COE of 76.3 mills/kWh.

**Table 3. Air Emissions Summary at 80% Capacity Factor**

Pollutant	GEE IGCC Without CSS
<b>CO<sub>2</sub></b>	
• million tonnes/year	3.408
• lb/MWh <sub>net</sub>	1,723
<b>SO<sub>2</sub></b>	
• tonne/year	21
• lb/MMBtu	0.0012
<b>NO<sub>x</sub></b>	
• tonne/year	1,023
• lb/MMBtu	0.059
<b>PM (filterable)</b>	
• tonne/year	123
• lb/MMBtu	0.0071
<b>Hg</b>	
• tonne/year	0.010
• lb/TBtu	0.571

Table 4. Major Financial Assumptions and Resulting Cost Summary<sup>1</sup>

<b>Major Assumptions</b>			
Case:	<b>1x622 MWe net GEE IGCC</b>		
Plant Size:	622.0 (MWe, net)	Heat Rate:	8,756 (Btu/kWh)
Primary/Secondary Fuel (type):	Illinois No. 6 Coal	Fuel Cost:	1.64 (\$/MMBtu)
Capital Expenditure Period:	5 (years)	Plant Life:	30 (years)
Cost Basis Year:	2007 (June)	Plant in Service:	2012 (June)
Capacity Factor:	80 (%)	Capital Charge Factor:	12.4 (%)
<b>Resulting Capital Investment (2007 dollars)</b>			<b>Mills/kWh</b>
Total Overnight Cost <sup>2</sup>			43.4
<b>Resulting Operating Costs (2007 dollars)<sup>3</sup></b>			<b>Mills/kWh</b>
Fixed Operating Cost			11.3
Variable Operating Cost			7.3
<b>Resulting Fuel Cost (2007 dollars) at \$1.80 / MMBtu</b>			<b>Mills/kWh</b>
			14.3
<b>Total Busbar Cost of Power (2007 dollars)</b>			<b>Mills/kWh</b>
			76.3

<sup>1</sup>Costs shown can vary -15%/+30%.

<sup>2</sup>Total overnight cost includes all equipment (complete with initial chemical and catalyst loadings), materials, labor (direct and indirect), engineering and construction management, and contingencies (process and project), and owner's cost.

<sup>3</sup>No credit taken for by-product sales.

**Contacts**

**James Black**  
 General Engineer  
 National Energy Technology Laboratory  
 626 Cochran's Mill Road  
 P.O. Box 10940  
 Pittsburgh, PA 15236  
 412-386-5458  
 james.black@netl.doe.gov

**Larry Rath**  
 Director of Performance Division  
 National Energy Technology Laboratory  
 626 Cochran's Mill Road  
 P.O. Box 10940  
 Pittsburgh, PA 15236  
 412-386-6871  
 larry.rath@netl.doe.gov

References

Cost and Performance Baseline for Fossil Energy Plants, Vol. I. (2010, November). Pittsburgh, PA. DOE/NETL-2010/1397.

CoalFleet User Design Basis Specification for Coal-Based Integrated Gasification Combined Cycle (IGCC) Power Plants, (2009). EPRI, Palo Alto, CA. 1017501.

# GE Energy IGCC Plant With Carbon Capture and Sequestration

## Plant Overview

This analysis is based on a 543 MWe (net power output) Integrated Gasification Combined-Cycle (IGCC) plant, using GE Energy (GEE) radiant-only gasification technology, located at a greenfield site in the midwestern United States. The plant utilizes carbon capture and sequestration (CCS). Two pressurized, slurry-fed, entrained-flow gasification trains, utilizing water-gas-shift (WGS) reactors, feed two advanced F-Class combustion turbines. Two heat recovery steam generators (HRSG) and one steam turbine provide additional power. Carbon dioxide (CO<sub>2</sub>) is removed with the two-stage Selexol physical solvent process. The combination process and heat and mass balance diagram for the GEE IGCC plant with CCS case is shown in Figure 1. The primary fuel is an Illinois No. 6 bituminous coal with an assumed higher heating value (HHV) of 11,666 Btu/lb. The capacity factor (CF) for the plant is 80 percent without sparing of major train components. A summary of plant performance data for the GEE IGCC plant with CCS case is presented in Table 1.

Table 1. Plant Performance Summary

Plant Type	GEE IGCC
Carbon capture	Yes
Net power output (kWe)	543,250
Net plant efficiency (%)	32.6
Primary fuel (type)	Illinois No. 6 coal
COE (mills/kWh) @ 80% CF	105.6
TPC/TOC (\$/kW)	2,711/3,334
Cost of CO <sub>2</sub> avoided <sup>1</sup> (\$/tonne)	43/66
Analogous/Supercritical PC Ref.	

<sup>1</sup>The avoided costs for each capture case are calculated using the analogous non-capture plant as the reference and again with SC PC without CO<sub>2</sub> capture as the reference.

Figure 1. Process Flow Diagram GEE IGCC with CCS

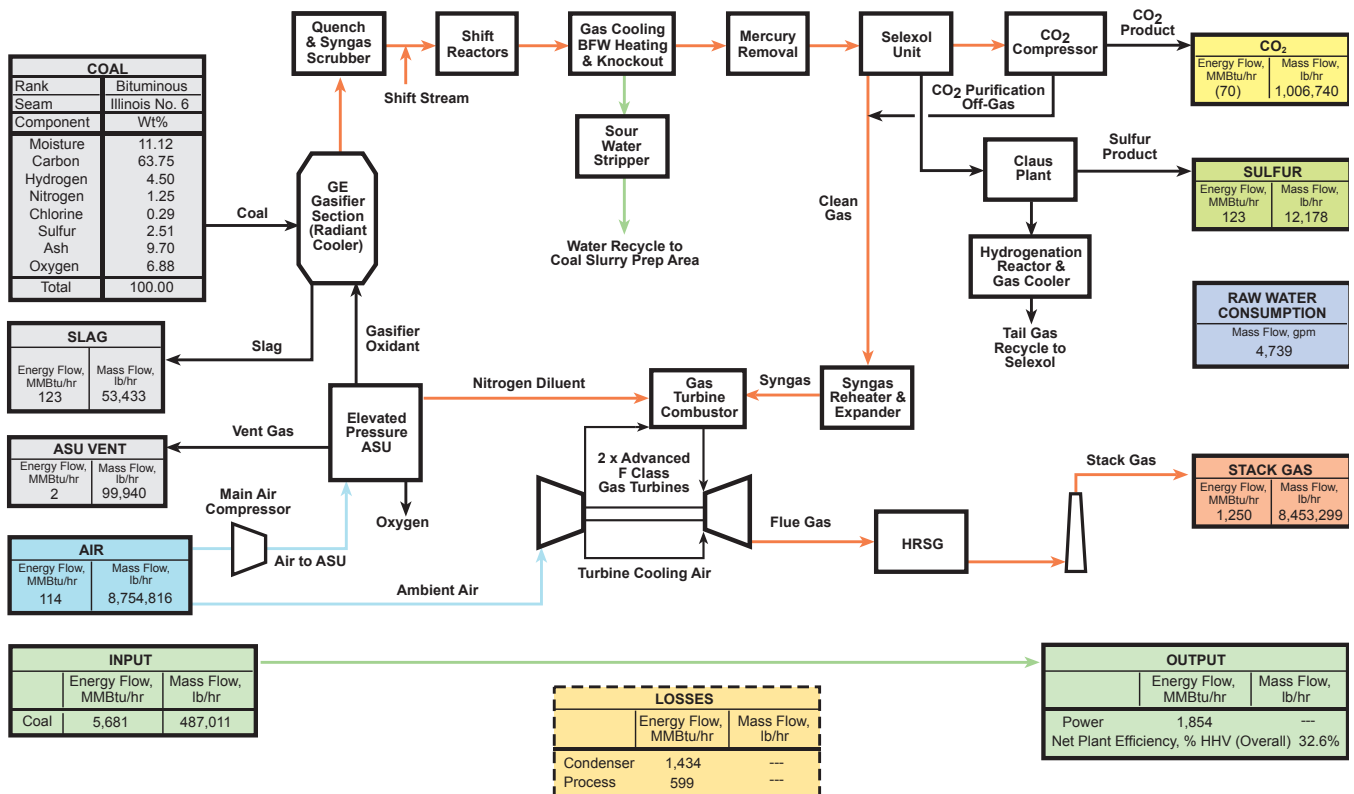

Note: Diagram is provided for general reference of major flows only. For complete flow information, please refer to the final report.

## Technical Description

The plant uses an improved version of the GEE gasification technology (formerly licensed by Chevron Corporation and predecessor company Texaco Inc.), which is currently in operation at the 250 MWe Tampa Electric IGCC plant in Polk County, Florida. All technology selected for the plant design is assumed to be available to facilitate a 2012 startup date for a newly constructed plant. However, because certain processes like the combustion turbine operating on a high-hydrogen content syngas and the two-stage Selexol process for CO<sub>2</sub> capture either have no commercial or limited commercial operating experience, a process contingency was included in those cost items.

Two gasification trains process a total of 5,302 tonnes of coal per day. A slurry (63 percent by weight coal) is transferred from the slurry storage tank to the gasifier with a high-pressure pump. Oxygen (O<sub>2</sub>) is produced in a cryogenic air separation unit. The coal slurry and O<sub>2</sub> react in the gasifier at about 5.6 MPa (815 psia) at a high temperature (in excess of 1,316°C [2,400°F]) to produce syngas. Hot syngas and molten solids from the reactor flow downward into a radiant heat exchanger, where the syngas is cooled to 677°C (1,250°F) and the ash solidifies. Raw syngas continues downward into a quench system where most of the particulate matter (PM) is removed and then into the syngas scrubber where most of the remaining entrained solids are removed along with halogens and ammonia. Slag captured by the quench system is recovered in a slag recovery unit. The gas goes through a series of additional gas coolers and cleanup processes, including a carbon bed for mercury (Hg) removal.

To capture CO<sub>2</sub>, a WGS reactor containing a series of two shifts with intercooled stages converts approximately 96 percent of the carbon monoxide to CO<sub>2</sub>. Carbon dioxide is removed from the cool, particulate-free gas stream with Selexol solvent. The dual-absorber Selexol acid gas removal (AGR) process preferentially removes hydrogen sulfide (H<sub>2</sub>S) as a product stream, leaving CO<sub>2</sub> as a separate product stream. The CO<sub>2</sub> is dried and compressed to 15.3 MPa (2,215 psia) for subsequent pipeline transport. The compressed CO<sub>2</sub> is transported via pipeline to a geologic sequestration field for injection into a saline aquifer, which is located within 50 miles of the plant.

A Brayton cycle, fueled by the syngas, is used in conjunction with a conventional subcritical steam Rankine cycle for combined-cycle power generation. The limiting factor that determines the use of a subcritical steam cycle is the maximum design pressure of 12.4 MPa (1,800 psig), which can be tolerated in the GEE radiant cooler. The two cycles are integrated by generation of steam in the HRSGs, by feedwater heating in the HRSGs, and by heat recovery from the IGCC process (radiant syngas cooler). The HRSG/steam turbine cycle is 12.4 MPa/538°C/538°C (1,800 psig/1,000°F/1,000°F). The plant produces a net output of 543 MWe. The summary of plant electrical generation performance is presented in Table 2. This configuration results in a net plant efficiency of 32.6 percent (HHV basis), or a net plant heat rate of 10,458 Btu/kWh.

**Table 2. Plant Electrical Generation**

	Electrical Summary
Advanced gas turbine x 2, MWe	464.0
HRSG steam turbine, MWe	263.5
Sweet gas expander, MWe	6.5
Gross power output, MWe	734
Auxiliary power requirement, MWe	(190.8)
Net power output, MWe	543.3

## Environmental Performance

The environmental specifications for a greenfield IGCC plant are based on the Electric Power Research Institute *CoalFleet User Design Basis for Coal-Based IGCC Plants* specification. Low sulfur dioxide (SO<sub>2</sub>) emissions (3 ppm in the flue gas) are achieved by capture of the sulfur in the Selexol AGR process, which removes 99 percent of the sulfur in the fuel gas. The resulting H<sub>2</sub>S-rich regeneration gas from the AGR system is fed to a Claus plant, producing elemental sulfur. Nitrogen oxides (NO<sub>x</sub>) emissions are limited by nitrogen dilution in the gas turbine combustor to 15 ppmvd (as nitrogen oxide at 15 percent O<sub>2</sub>). Particulate discharge to the atmosphere is

limited by the use of the syngas quench in addition to the syngas scrubber and the gas-washing effect of the AGR absorber. Ninety-five percent of the Hg is captured from the syngas by an activated carbon bed. Ninety percent of the CO<sub>2</sub> from the syngas is captured in the AGR system and compressed for pipeline transport and sequestration.

A summary of the resulting air emissions for the GEE IGCC plant with CCS is presented in Table 3.

### Cost Estimation

Estimates of capital and operations costs were developed for each plant based on adjusted vendor-furnished and actual cost data from recent design/build projects. These costs were used to calculate a first year cost-of-electricity (COE) based on the power plant costs and assumed financing structure. Financial assumptions and a cost summary are shown in Table 4.

Project contingencies were added to each case to cover project uncertainty and the cost of any additional equipment that could result from detailed design. The project contingencies represent costs that are expected to occur. Project contingency was 11.1 percent of the GEE IGCC with CCS case Total Plant Cost (TPC).

Process contingency is intended to compensate for uncertainties arising as a result of the state of technology development. Process contingencies represent 4.2 percent of the GEE IGCC with CCS case TPC and have been applied to the estimates as follows:

- Slurry Prep and Feed – 5 percent on GE IGCC cases
- Gasifiers and Syngas Coolers – 15 percent on all IGCC cases
- Two Stage Selexol – 20 percent on all IGCC CCS cases
- Mercury Removal – 5 percent on all IGCC cases
- Combustion Turbine Generator – 10 percent on all IGCC cases with CCS
- Instrumentation and Controls – 5 percent on all IGCC cases

This study assumes that each new plant would be dispatched any time it is available and would be capable of generating maximum capacity when online. Therefore, CF is assumed to equal availability and is 80 percent for IGCC cases.

The calculated cost of transport, storage, and monitoring (TS&M) for CO<sub>2</sub> adds 5.2 mills/kWh to the COE.

The 543.2 MWe (net) GEE IGCC plant with CCS was projected to have a Total Overnight Cost (TOC) of \$3,334/kWe, resulting in a COE of 105.6 mills/kWh.

**Table 3. Air Emissions Summary at 80% Capacity Factor**

Pollutant	GEE IGCC with CCS (90%)
<b>CO<sub>2</sub></b>	
• million tonnes/year	0.355
• lb/MWh <sub>net</sub>	206
<b>SO<sub>2</sub></b>	
• tonne/year	39
• lb/MMBtu	0.0022
<b>NO<sub>x</sub></b>	
• tonne/year	878
• lb/MMBtu	0.049
<b>PM (filterable)</b>	
• tonne/year	128
• lb/MMBtu	0.0071
<b>Hg</b>	
• tonne/year	0.010
• lb/TBtu	0.571

Table 5. Major Financial Assumptions and Resulting Cost Summary<sup>1</sup>

<b>Major Assumptions</b>			
Case:	<b>1x543 MWe net GEE IGCC with CCS</b>		
Plant Size:	543.3 (MWe, net)	Heat Rate:	10,458 (Btu/kWh)
Primary/Secondary Fuel (type):	Illinois No. 6 Coal	Fuel Cost:	1.64 (\$/MMBtu)
Capital Expenditure Period:	5 (years)	Plant Life:	30 (years)
Cost Basis Year:	2007 (June)	Plant in Service:	2012 (June)
Capacity Factor:	80 (%)	Capital Charge Factor:	12.4 (%)
<b>Resulting Capital Investment (2007 dollars)</b>			<b>Mills/kWh</b>
Total Overnight Cost <sup>2</sup>			59.1
<b>Resulting Operating Costs (2007 dollars)<sup>3</sup></b>			<b>Mills/kWh</b>
Fixed Operating Cost			14.8
Variable Operating Cost			9.3
<b>Resulting Fuel Cost (2007 dollars) at \$1.80 / MMBtu</b>			<b>Mills/kWh</b>
			17.1
<b>Resulting CO<sub>2</sub> Cost (2007 dollars)</b>			<b>Mills/kWh</b>
			5.2
<b>Total Busbar Cost of Power (2007 dollars)</b>			<b>Mills/kWh</b>
			105.6

<sup>1</sup>Costs shown can vary -15%/+30%.

<sup>2</sup>Total overnight cost includes all equipment (complete with initial chemical and catalyst loadings), materials, labor (direct and indirect), engineering and construction management, and contingencies (process and project), and owner’s cost.

<sup>3</sup>No credit taken for by-product sales.

### Contacts

**James Black**  
 General Engineer  
 National Energy Technology Laboratory  
 626 Cochrans Mill Road  
 P.O. Box 10940  
 Pittsburgh, PA 15236  
 412-386-5458  
 james.black@netl.doe.gov

**Larry Rath**  
 Director of Performance Division  
 National Energy Technology Laboratory  
 626 Cochrans Mill Road  
 P.O. Box 10940  
 Pittsburgh, PA 15236  
 412-386-6871  
 larry.rath@netl.doe.gov

### References

Cost and Performance Baseline for Fossil Energy Plants, Vol. 1. (2010, November). Pittsburgh, PA. DOE/NETL-2010/1397.

CoalFleet User Design Basis Specification for Coal-Based Integrated Gasification Combined Cycle (IGCC) Power Plants, (2009). EPRI, Palo Alto, CA. 1017501.



# ConocoPhillips E-Gas™ IGCC Plant

## Plant Overview

This analysis is based on a 625 MWe (net power output) Integrated Gasification Combined-Cycle (IGCC) plant, using ConocoPhillips (CoP) E-Gas™ gasification technology, located at a greenfield site in the midwestern United States. Two pressurized entrained-flow, two-stage gasification trains feed two advanced F-Class combustion turbines. Two heat recovery steam generators (HRSG) and one steam turbine provide additional power. The combination process and heat and mass balance diagram for the CoP IGCC plant is shown in Figure I. The primary fuel is an Illinois No. 6 bituminous coal with a higher heating value (HHV) of 11,666 Btu/lb. The capacity factor (CF) for the plant is 80 percent without sparing of major train components. A summary of plant performance data for the CoP IGCC plant is presented in Table I.

Table I. Plant Performance Summary

Plant Type	CoP IGCC
Carbon capture	No
Net power output (kWe)	625,060
Net plant efficiency (%)	39.7
Primary fuel	Illinois No. 6 coal
COE (mills/kWh) @ 80% CF	74.0
TPC/TOC (\$/kW)	1,913/2,351

Figure I. Process Flow Diagram  
CoP IGCC

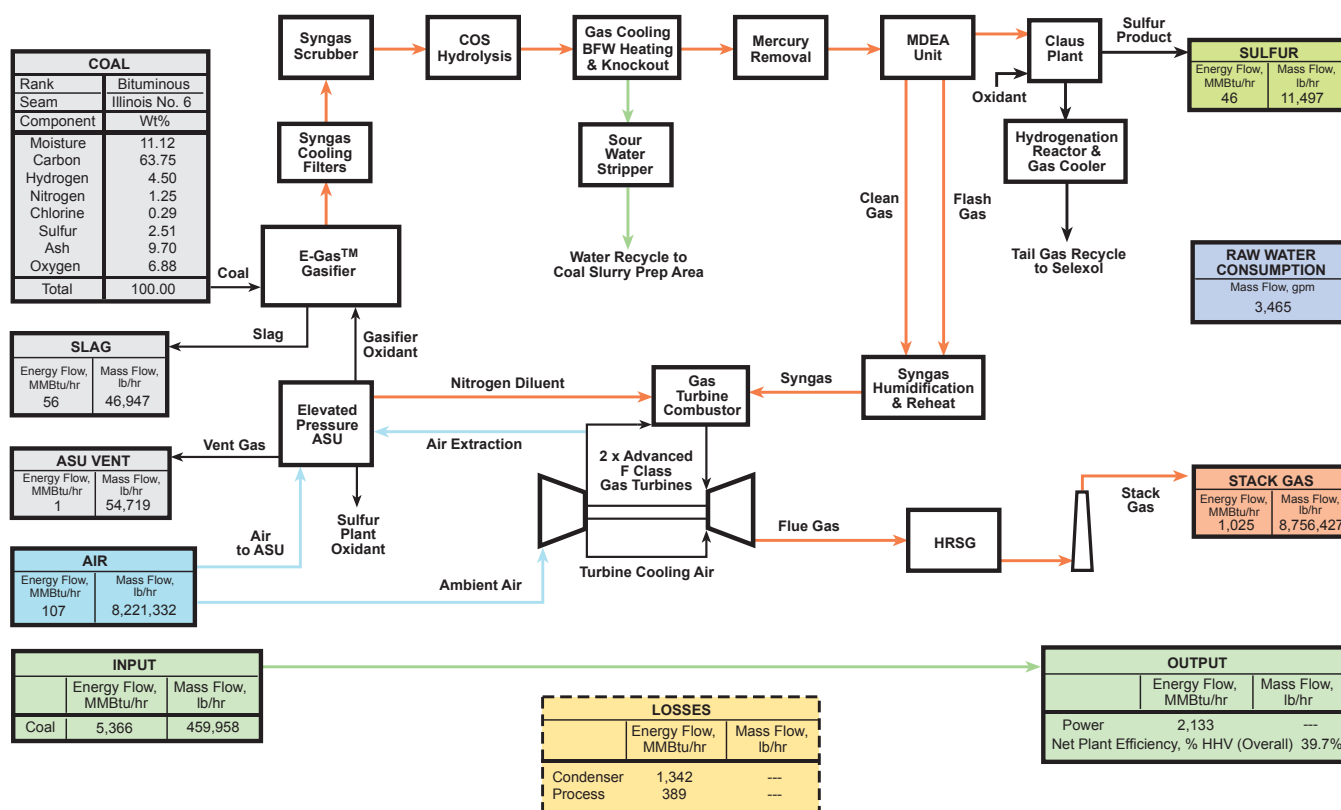

Note: Diagram is provided for general reference of major flows only. For complete flow information, please refer to the final report.

## Technical Description

The plant uses an improved version of the CoP gasification technology, which is currently in operation at the PSI Energy Inc. 265 MWe Wabash River IGCC plant near West Terre Haute, Indiana. All technology selected in the plant design is assumed to be available to facilitate a 2012 startup date for a newly constructed plant.

Two gasification trains process a total of 5,567 tons of coal per day. A slurry (63 percent by weight coal) is transferred from the slurry storage tank to the gasifier with a 78/22 split to the primary and secondary stages. Oxygen (O<sub>2</sub>) is produced in a cryogenic air separation unit. The coal slurry and oxygen react in the gasifier at about 4.2 MPa (615 psia) at a high temperature (averaging 1,371 °C [ $>2,500^{\circ}\text{F}$ ]), while the portion of slurry injected into the second stage quenches the reaction by means of endothermic gasification reactions.

Gas leaving the gasifier is cooled in a fire-tube syngas cooler producing high-pressure steam. The cooled gas is cleaned of particulate matter (PM) via a cyclone collector followed by a ceramic candle filter. The raw syngas is then further cooled before being cleaned in a spray scrubber to remove remaining particulates and trace components. The syngas goes through a mercury (Hg) removal bed in which 95 percent of the Hg is removed from the syngas with activated carbon. Hydrogen sulfide (H<sub>2</sub>S) is removed from the cool, particulate-free gas stream with a refrigerated promoted amine (methyldiethanolamine) solvent. Elemental sulfur is recovered in a Claus bypass-type sulfur recovery unit utilizing oxygen instead of air. The Claus plant produces molten sulfur by converting about one-third of the H<sub>2</sub>S in the feed to sulfur dioxide (SO<sub>2</sub>), then reacting the H<sub>2</sub>S and SO<sub>2</sub> to produce sulfur and water.

A Brayton cycle, fueled by syngas, is used in conjunction with a conventional subcritical steam Rankine cycle for combined-cycle power generation. Compressed nitrogen from the air separation unit is used in syngas dilution, which aids in minimizing the formation of nitrogen oxides (NO<sub>x</sub>) during combustion in the gas turbine burner section. Two HRSGs and a steam turbine, operating at 12.4 MPa/566 °C/566 °C (1,800 psig/1,050 °F/1,050 °F), form the combined-cycle generation component of the plant. The two cycles are integrated by generation of steam in the HRSG, by feedwater heating in the HRSG, and by heat recovery from the IGCC process (syngas cooler). The plant produces a net output of 625 MWe. The summary of plant electrical generation performance is presented in Table 2. This configuration results in a net plant efficiency of 39.7 percent (HHV basis), or a net plant heat rate of 8,585 Btu/kWh.

**Table 2. Plant Electrical Generation**

	Electrical Summary
Advanced gas turbine x 2, MWe	464.0
HRSG steam turbine, MWe	274.2
Gross power output, MWe	738.2
Auxiliary power requirement, MWe	(113.1)
Net power output, MWe	625

## Environmental Performance

The environmental specifications for a greenfield IGCC plant are based on the Electric Power Research Institute *CoalFleet User Design Basis for Coal-Based IGCC Plants* specification. Low SO<sub>2</sub> emissions (less than 4 ppmv in the flue gas) are achieved by capture of the sulfur in the Coastal SS Amine acid gas removal (AGR) process, which removes over 99 percent of the sulfur in the fuel gas to less than 30 ppmv. The resulting hydrogen sulfide-rich regeneration gas from the acid gas removal system is fed to a Claus plant, producing elemental sulfur. Nitrogen oxides emissions are limited by nitrogen dilution (primarily) and humidification (secondarily) to 15 ppmvd (as nitrogen dioxide at 15 percent O<sub>2</sub>). Filterable PM discharge to the atmosphere is limited by a cyclone and a barrier filter in addition to the syngas scrubber and the gas washing effect of the AGR absorber. Ninety-five percent of the Hg is captured from the syngas by an activated carbon bed.

A summary of the resulting air emissions for the CoP IGCC plant is presented in Table 3.

### Cost Estimation

Estimates of capital and operations costs were developed for each plant based on adjusted vendor-furnished and actual cost data from recent design/build projects. These costs were used to calculate a first year cost-of-electricity (COE) based on the power plant costs and assumed financing structure. Financial assumptions and a cost summary are shown in Table 4.

Project contingencies were added to each case to cover project uncertainty and the cost of any additional equipment that could result from detailed design. The project contingencies represent costs that are expected to occur. Project contingency was 10.9 percent of the CoP IGCC case Total Plant Cost (TPC).

Process contingency is intended to compensate for uncertainties arising as a result of the state of technology development. Process contingencies represent 2.1 percent of the CoP IGCC case TPC and have been applied to the estimates as follows:

- Gasifiers and Syngas Coolers – 15 percent on all IGCC cases
- Mercury Removal – 5 percent on all IGCC cases
- Combustion Turbine Generator – 5 percent on all IGCC cases without CCS
- Instrumentation and Controls – 5 percent on all IGCC cases

This study assumes that each new plant would be dispatched any time it is available and would be capable of generating maximum capacity when online. Therefore, CF is assumed to equal availability and is 80 percent for IGCC cases.

The 625 MWe (net) CoP IGCC plant was projected to have a Total Overnight Cost (TOC) of \$2,351/kWe, resulting in COE of 74.0 mills/kWh.

Table 3. Air Emissions Summary at 80% Capacity Factor

Pollutant	CoP IGCC Without CCS
<b>CO<sub>2</sub></b>	
• million tonnes/year	3.398
• lb/MWh <sub>net</sub>	1,710
<b>SO<sub>2</sub></b>	
• tonne/year	200
• lb/MMBtu	0.0117
<b>NO<sub>x</sub></b>	
• tonne/year	1,017
• lb/MMBtu	0.060
<b>PM (filterable)</b>	
• tonne/year	121
• lb/MMBtu	0.0071
<b>Hg</b>	
• tonne/year	0.010
• lb/TBtu	0.571

Table 4 Major Financial Assumptions and Resulting Cost Summary<sup>1</sup>

<b>Major Assumptions</b>			
Case:	<b>1x625 MWe net CoP IGCC</b>		
Plant Size:	625.0 (MWe, net)	Heat Rate:	8,585 (Btu/kWh)
Primary/Secondary Fuel (type):	Illinois No. 6 Coal	Fuel Cost:	1.64 (\$/MMBtu)
Capital Expenditure Period:	5 (years)	Plant Life:	30 (years)
Cost Basis Year:	2007 (June)	Plant in Service:	2012 (June)
Capacity Factor:	80 (%)	Capital Charge Factor:	12.4 (%)
<b>Resulting Capital Investment (2007 dollars)</b>			<b>Mills/kWh</b>
Total Overnight Cost <sup>2</sup>			41.7
<b>Resulting Operating Costs (2007 dollars)<sup>3</sup></b>			<b>Mills/kWh</b>
Fixed Operating Cost			11.1
Variable Operating Cost			7.2
<b>Resulting Fuel Cost (2007 dollars) at \$1.80 / MMBtu</b>			<b>Mills/kWh</b>
			14.0
<b>Total Busbar Cost of Power (2007 dollars)</b>			<b>Mills/kWh</b>
			74.0

<sup>1</sup>Costs shown can vary -15%/+30%.

<sup>2</sup>Total overnight cost includes all equipment (complete with initial chemical and catalyst loadings), materials, labor (direct and indirect), engineering and construction management, and contingencies (process and project), and owner’s cost.

<sup>3</sup>No credit taken for by-product sales.

**Contacts**

**James Black**  
 General Engineer  
 National Energy Technology Laboratory  
 626 Cochran Mill Road  
 P.O. Box 10940  
 Pittsburgh, PA 15236  
 412-386-5458  
 james.black@netl.doe.gov

**Larry Rath**  
 Director of Performance Division  
 National Energy Technology Laboratory  
 626 Cochran Mill Road  
 P.O. Box 10940  
 Pittsburgh, PA 15236  
 412-386-6871  
 larry.rath@netl.doe.gov

References

Cost and Performance Baseline for Fossil Energy Plants, Vol. 1. (2010, November). Pittsburgh, PA. DOE/NETL-2010/1397.

CoalFleet User Design Basis Specification for Coal-Based Integrated Gasification Combined Cycle (IGCC) Power Plants, (2009). EPRI, Palo Alto, CA. 1017501.

# ConocoPhillips E-Gas™ IGCC Plant With Carbon Capture and Sequestration

## Plant Overview

This analysis is based on a 514 MWe (net power output) Integrated Gasification Combined-Cycle (IGCC) plant, using ConocoPhillips (CoP) E-Gas™ gasification technology, located at a greenfield site in the midwestern United States. The plant utilizes carbon capture and sequestration (CCS). Two pressurized entrained-flow, two-stage gasification trains feed two advanced F-Class combustion turbines. Water-gas-shift (WGS) reactors are used for sour gas shift. Two heat recovery steam generators (HRSG) and one steam turbine provide additional power. Carbon dioxide (CO<sub>2</sub>) is removed with the two-stage Selexol physical solvent process. The combination process and heat and mass balance diagram for the CoP IGCC plant with CCS is shown in Figure 1. The primary fuel is an Illinois No. 6 bituminous coal with a higher heating value (HHV) of 11,666 Btu/lb. The capacity factor (CF) for the plant is 80 percent without sparing of major train components. A summary of plant performance data for the CoP IGCC plant with CCS is presented in Table 1.

Table 1. Plant Performance Summary

Plant Type	CoP IGCC
Carbon capture	Yes
Net power output (kWe)	513,610
Net plant efficiency (%)	31.0
Primary fuel (type)	Illinois No. 6 coal
COE (mills/kWh) @ 80% CF	110.3
TPC/TOC (\$/kW)	2,817/3,466
Cost of CO <sub>2</sub> avoided <sup>1</sup> (\$/tonne)	54/73
Analogous/Supercritical PC Ref.	

<sup>1</sup>The avoided costs for each capture case are calculated using the analogous non-capture plant as the reference and again with SC PC without CO<sub>2</sub> capture as the reference.

Figure 1. Process Flow Diagram  
CoP IGCC With CCS

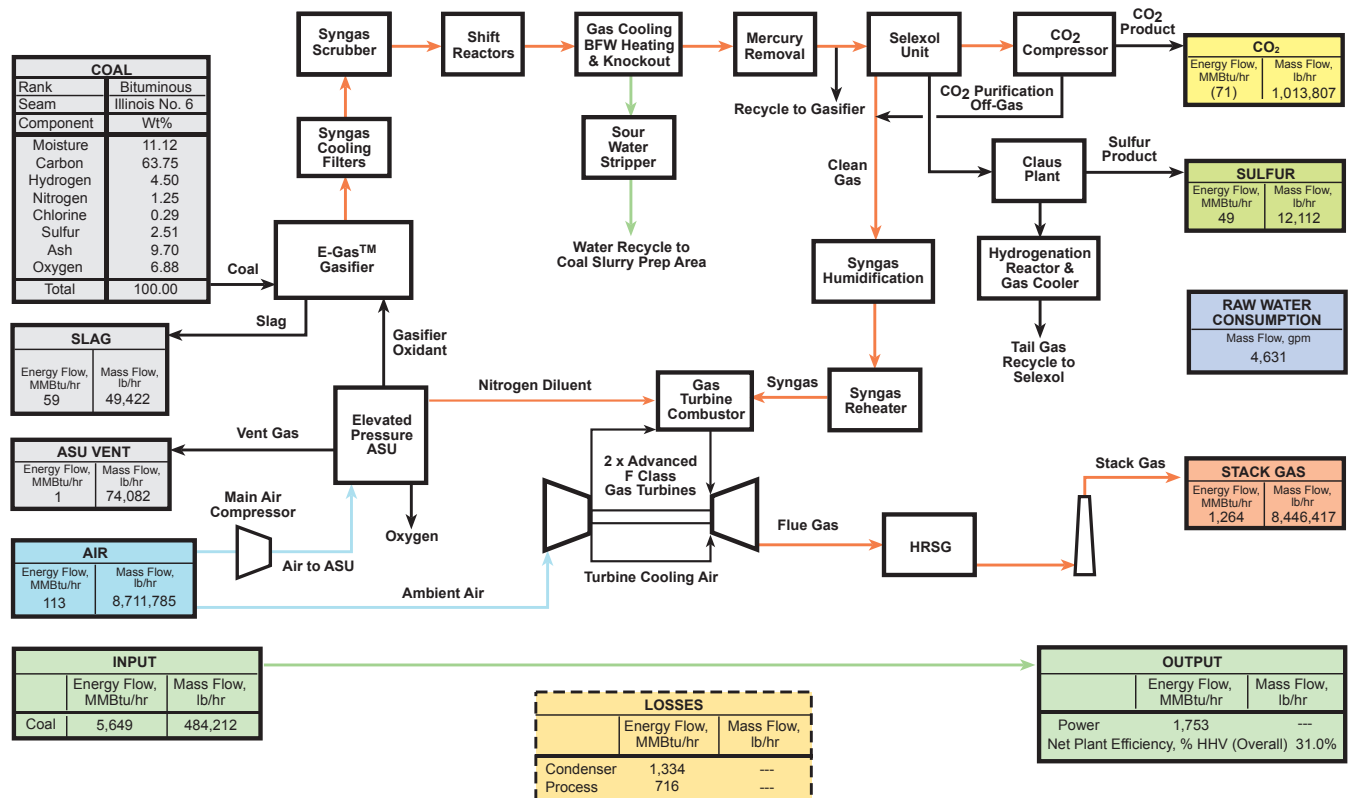

Note: Diagram is provided for general reference of major flows only. For complete flow information, please refer to the final report.

## Technical Description

The plant uses an improved version of the CoP gasification technology, which is currently in operation at the PSI Energy Inc. 265 MWe Wabash River IGCC plant near West Terre Haute, Indiana. All technology selected for the plant design is assumed to be available to facilitate a 2012 startup date for a newly constructed plant. However, because certain processes like the combustion turbine operating on a high-hydrogen content syngas and the two-stage Selexol process for CO<sub>2</sub> capture either have no commercial or limited commercial operating experience, a process contingency was included in those cost items.

Two gasification trains process a total of 5,271 tonnes of coal per day. A slurry (63 percent by weight coal) is transferred from the slurry storage tank to the two-stage gasifier with a 78/22 split to the primary and secondary stages. Oxygen (O<sub>2</sub>) is produced in a cryogenic air separation unit. The coal slurry and O<sub>2</sub> react in the gasifier at about 4.2 MPa (615 psia) at a high temperature (averaging 1,371°C [2,500°F]), while the portion of slurry injected into the second stage quenches the reaction by means of endothermic gasification reactions.

Gas leaving the gasifier is cooled in a fire-tube syngas cooler producing high-pressure steam. The cooled gas is cleaned of particulate matter (PM) via a cyclone collector followed by a ceramic candle filter. The raw syngas is then further cooled before being cleaned in a spray scrubber to remove remaining particulates and trace components. The syngas goes through a mercury (Hg) removal bed in which 95 percent of the Hg is removed from the syngas with activated carbon. Hydrogen sulfide (H<sub>2</sub>S) is removed from the cool, particulate-free gas stream with a Selexol acid gas removal (AGR) system. Elemental sulfur is recovered in a Claus bypass-type sulfur recovery unit utilizing oxygen instead of air. The Claus plant produces molten sulfur by converting about one-third of the H<sub>2</sub>S in the feed to sulfur dioxide (SO<sub>2</sub>), then reacting the H<sub>2</sub>S and SO<sub>2</sub> to produce sulfur and water.

To capture CO<sub>2</sub>, a WGS reactor containing a series of three shifts with intercooled stages converts a nominal 98 percent of the carbon monoxide to CO<sub>2</sub>. Carbon dioxide is removed from the cool, particulate-free gas stream with Selexol solvent. The double-absorber Selexol process preferentially removes H<sub>2</sub>S as a product stream, leaving CO<sub>2</sub> as a separate product stream. The CO<sub>2</sub> is dried and compressed to 15.3 MPa (2,215 psia) for subsequent pipeline transport. The compressed CO<sub>2</sub> is transported via pipeline to a geologic sequestration field for injection into a saline aquifer, which is located within 50 miles of the plant.

A Brayton cycle, fueled by the syngas, is used in conjunction with a conventional subcritical steam Rankine cycle for combined-cycle power generation. Two HRSGs and a steam turbine, operating at 12.4 MPa/538°C/538°C (1,800 psig/1,000°F/1,000°F), form the combined-cycle generation component of the plant. The two cycles are integrated by generation of steam in the HRSGs, by feedwater heating in the HRSGs, and by heat recovery from the IGCC process (syngas cooler). The plant produces a net output of 514 MWe. The summary of plant electrical generation performance is presented in Table 2. This configuration results in a net plant efficiency of 31.0 percent (HHV basis), or a net plant heat rate of 10,998 Btu/kWh.

**Table 2. Plant Electrical Generation**

	Electrical Summary
Advanced gas turbine x 2, MWe	464.0
Steam turbine, MWe	239.7
Gross power output, MWe	703.7
Auxiliary power requirement, MWe	(190.0)
Net power output, MWe	513.6

## Environmental Performance

The environmental specifications for a greenfield IGCC plant are based on the Electric Power Research Institute *CoalFleet User Design Basis for Coal-Based IGCC Plants* specification. Low SO<sub>2</sub> emissions (less than 3 ppmv in the flue gas) are achieved by capture of the sulfur in the Selexol AGR process, which removes 99 percent of the sulfur in the fuel gas to less than 22 ppmv. The resulting H<sub>2</sub>S-rich regeneration gas from the acid gas removal system is fed to a Claus plant, producing elemental sulfur. Nitrogen oxides (NO<sub>x</sub>)

emissions are limited by nitrogen dilution (primarily) and syngas humidification (secondarily) to 15 ppmvd (as nitrogen dioxide at 15 percent O<sub>2</sub>). Filterable PM discharge to the atmosphere is limited by a cyclone and a barrier filter in addition to the syngas scrubber and the gas-washing effect of the AGR absorber. Ninety-five percent of the Hg is captured from the syngas by an activated carbon bed. About eighty-eight percent of the CO<sub>2</sub> from the syngas is captured in the AGR system and compressed for shipment and sequestration.

A summary of the resulting air emissions for the CoP IGCC plant with CCS is presented in Table 3.

### Cost Estimation

Estimates of capital and operations costs were developed for each plant based on adjusted vendor-furnished and actual cost data from recent design/build projects. These costs were used to calculate a first year cost-of-electricity (COE) based on the power plant costs and assumed financing structure. Financial assumptions and a cost summary are shown in Table 4.

Project contingencies were added to each case to cover project uncertainty and the cost of any additional equipment that could result from detailed design. The project contingencies represent costs that are expected to occur. Project contingency was 11.1 percent of the CoP IGCC with CCS case Total Plant Cost (TPC).

Process contingency is intended to compensate for uncertainties arising as a result of the state of technology development. Process contingencies represent 3.5 percent of the CoP IGCC with CCS case TPC and have been applied to the estimates as follows:

- Gasifiers and Syngas Coolers – 15 percent on all IGCC cases
- Two Stage Selexol – 20 percent on all IGCC CCS cases
- Mercury Removal – 5 percent on all IGCC cases
- Combustion Turbine Generator – 10 percent on all IGCC cases with CCS
- Instrumentation and Controls – 5 percent on all IGCC cases

This study assumes that each new plant would be dispatched any time it is available and would be capable of generating maximum capacity when online. Therefore, CF is assumed to equal availability and is 80 percent for IGCC cases.

The 513.6 MWe (net) CoP IGCC plant with CCS was projected to have a Total Overnight Cost (TOC) of \$3,466/kWe, resulting in a COE of 110.4 mills/kWh.

**Table 3. Air Emissions Summary at 80% Capacity Factor**

Pollutant	CoP IGCC With CCS (90%)
<b>CO<sub>2</sub></b>	
• million tonnes/year	0.354
• lb/MWh <sub>net</sub>	217
<b>SO<sub>2</sub></b>	
• tonne/year	39
• lb/MMBtu	0.0022
<b>NO<sub>x</sub></b>	
• tonne/year	885
• lb/MMBtu	0.049
<b>PM (filterable)</b>	
• tonne/year	127
• lb/MMBtu	0.0071
<b>Hg</b>	
• tonne/year	0.010
• lb/TBtu	0.571

Table 4. Major Financial Assumptions and Resulting Cost Summary<sup>1</sup>

<b>Major Assumptions</b>			
Case:	<b>1x514 MWe net CoP IGCC with CCS</b>		
Plant Size:	513.6 (MWe, net)	Heat Rate:	10,998 (Btu/kWh)
Primary/Secondary Fuel (type):	Illinois No. 6 Coal	Fuel Cost:	1.64 (\$/MMBtu)
Capital Expenditure Period:	5 (years)	Plant Life:	30 (years)
Cost Basis Year:	2007 (June)	Plant in Service:	2012 (June)
Capacity Factor:	80 (%)	Capital Charge Factor:	12.4 (%)
<b>Resulting Capital Investment (2007 dollars)</b>			<b>Mills/kWh</b>
Total Overnight Cost <sup>2</sup>			61.5
<b>Resulting Operating Costs (2007 dollars)<sup>3</sup></b>			<b>Mills/kWh</b>
Fixed Operating Cost			15.5
Variable Operating Cost			9.8
<b>Resulting Fuel Cost (2007 dollars) at \$1.80 / MMBtu</b>			<b>Mills/kWh</b>
			18.0
<b>Resulting CO<sub>2</sub> Cost (2007 dollars)</b>			<b>Mills/kWh</b>
			5.5
<b>Total Busbar Cost of Power (2007 dollars)</b>			<b>Mills/kWh</b>
			110.3

<sup>1</sup>Costs shown can vary -15%/+30%.

<sup>2</sup>Total overnight cost includes all equipment (complete with initial chemical and catalyst loadings), materials, labor (direct and indirect), engineering and construction management, and contingencies (process and project), and owner’s cost.

<sup>3</sup>No credit taken for by-product sales.

### Contacts

**James Black**  
 General Engineer  
 National Energy Technology Laboratory  
 626 Cochrans Mill Road  
 P.O. Box 10940  
 Pittsburgh, PA 15236  
 412-386-5458  
 james.black@netl.doe.gov

**Larry Rath**  
 Director of Performance Division  
 National Energy Technology Laboratory  
 626 Cochrans Mill Road  
 P.O. Box 10940  
 Pittsburgh, PA 15236  
 412-386-6871  
 larry.rath@netl.doe.gov

### References

Cost and Performance Baseline for Fossil Energy Plants, Vol. 1. (2010, November). Pittsburgh, PA. DOE/NETL-2010/1397.

CoalFleet User Design Basis Specification for Coal-Based Integrated Gasification Combined Cycle (IGCC) Power Plants, (2009). EPRI, Palo Alto, CA. 1017501.



# Shell IGCC Plant

## Plant Overview

This analysis is based on a 629 MWe (net power output) Integrated Gasification Combined-Cycle (IGCC) plant using Shell Global Solutions gasification technology located at a greenfield site in the midwestern United States. Two pressurized dry-feed entrained flow gasification trains feed two advanced F-Class combustion turbines. Two heat recovery steam generators (HRSG) and one steam turbine provide additional power. The combination process and heat and mass balance diagram for the Shell IGCC plant is shown in Figure 1. The primary fuel is an Illinois No. 6 bituminous coal with a higher heating value (HHV) of 11,666 Btu/lb. The capacity factor (CF) for the plant is 80 percent without sparing of major train components. A summary of plant performance data for the Shell IGCC plant is presented in Table I.

Table I. Plant Performance Summary

Plant Type	Shell IGCC
Carbon capture	No
Net power output (kWe)	628,980
Net plant efficiency (%)	42.1
Primary fuel (type)	Illinois No. 6 coal
COE (mills/kWh) @ 80% CF	81.3
TPC/TOC (\$/kW)	2,217/2,716

Figure 1. Process Flow Diagram Shell IGCC

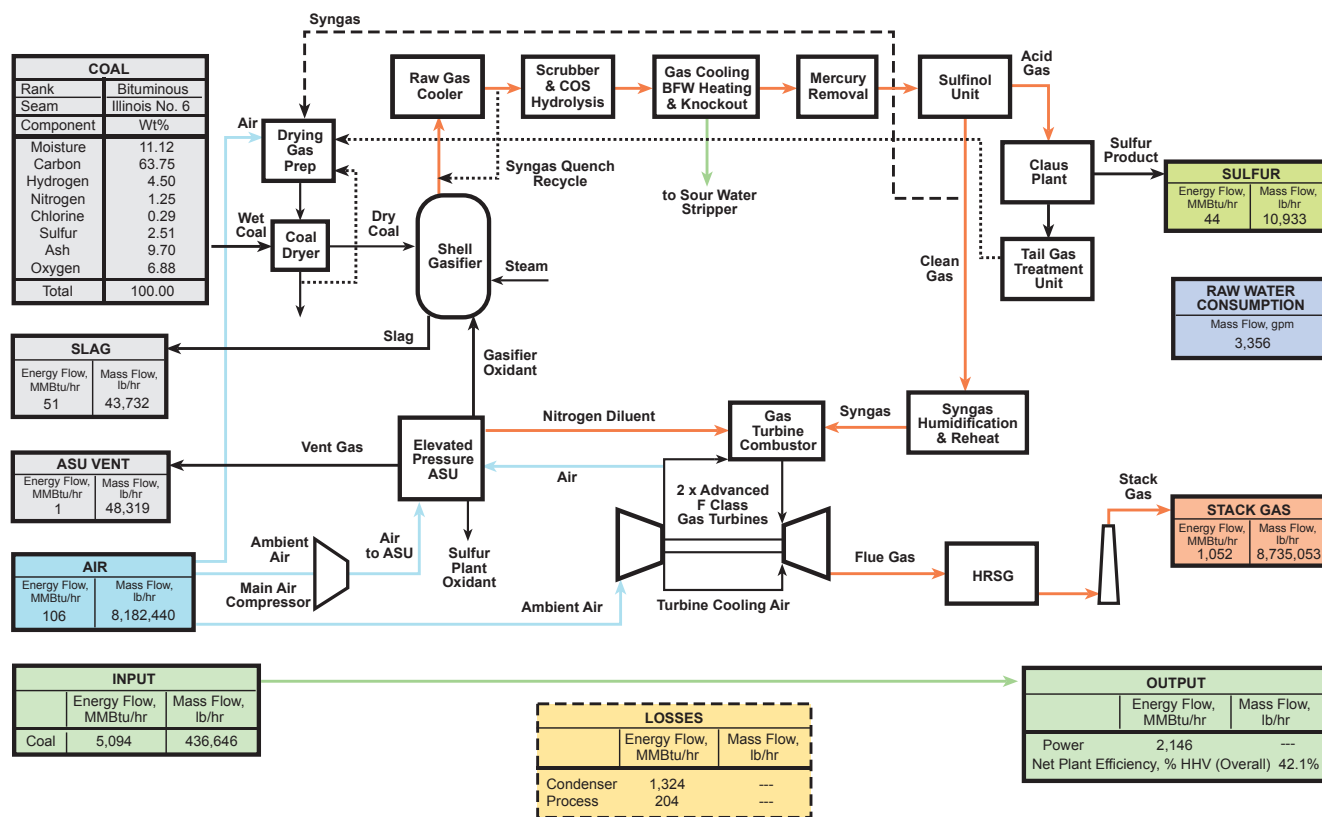

Note: Diagram is provided for general reference of major flows only. For complete flow information, please refer to the final report.

## Technical Description

The plant uses the Shell gasification technology. All technology selected in this plant design is assumed to be available to facilitate a 2012 startup date for a newly constructed plant.

Two gasification trains process a total of 4,753 tonnes of coal per day. Dry coal is introduced to the gasifier via lockhoppers. Oxygen (O<sub>2</sub>) is produced in a cryogenic air separation unit. The coal reacts with O<sub>2</sub> at about 1,427°C (2,600°F) to produce medium heating value syngas. The syngas is then quenched to around 891°C (1,635°F) by cooled recycled syngas. The syngas passes through a convective cooler and leaves at a temperature near 316°C (600°F). High-pressure saturated steam is generated in the syngas cooler and is joined with the main steam supply. The syngas passes through a cyclone and a raw gas candle filter where a majority of the fine particles are removed. The ash that is not carried out with the gas forms slag and runs down the interior walls, exiting the gasifier in liquid form.

The raw syngas then enters a scrubber for removal of chlorides and remaining particulate matter (PM). Following the scrubber, the raw syngas is reheated to 177°C (350°F) and fed to a Carbonyl Sulfide (COS) hydrolysis reactor where COS is catalytically converted to Hydrogen Sulfide (H<sub>2</sub>S). The syngas is then cooled to about 35°C (95°F) before passing through a carbon bed to remove ninety five percent of the Hg. The Sulfinol process then removes essentially all of the CO<sub>2</sub> along with the H<sub>2</sub>S and COS. Elemental sulfur is recovered in a Claus bypass-type sulfur recovery unit utilizing O<sub>2</sub> instead of air. The Claus plant produces molten sulfur by converting about one-third of the H<sub>2</sub>S in the feed to sulfur dioxide (SO<sub>2</sub>), then reacting the H<sub>2</sub>S and SO<sub>2</sub> to produce sulfur and water.

A Brayton cycle fueled with syngas is used in conjunction with a conventional subcritical steam Rankine cycle. Nitrogen dilution (primarily), syngas humidification (secondarily) and steam injection to a lesser extent aid in minimizing formation of nitrogen oxides (NO<sub>x</sub>) during combustion in the gas turbine burner section. Two HRSGs and a steam turbine, operating at 12.4 MPa/566°C/566°C (1,800 psig/1,050°F/1,050°F), form the combined-cycle generation component of the plant. The two cycles are integrated by generation of steam in the HRSG, by feedwater heating in the HRSG, and by heat recovery from the IGCC process (convective syngas cooler). The plant produces a net output of 629 MWe. The summary of plant electrical generation performance is presented in Table 2. This configuration results in a net plant efficiency of 42.1 percent (HHV basis) or a net plant heat rate of 8,099 Btu/kWh.

**Table 2. Plant Electrical Generation**

	Electrical Summary
Advanced gas turbine x 2, MWe	464.0
HRSG steam turbine, MWe	273.0
Gross power output, MWe	737.0
Auxiliary power requirement, MWe	(108.0)
Net power output, MWe	629.0

## Environmental Performance

The environmental specifications for a greenfield IGCC plant are based on the Electric Power Research Institute *CoalFleet User Design Basis for Coal-Based IGCC Plants* specification. Low SO<sub>2</sub> emissions (less than 4 ppmv in the flue gas) are achieved by capture of the sulfur in the Sulfinol-MAGR process, which removes over 99 percent of the sulfur in the fuel gas. The resulting hydrogen sulfide-rich regeneration gas from the AGR system is fed to a Claus plant, producing elemental sulfur. Nitrogen oxides emissions are limited by syngas humidification and nitrogen dilution in the gas turbine combustor to 15 ppmvd (as nitrogen oxides at 15 percent O<sub>2</sub>). Filterable PM discharge to the atmosphere is limited by the use of a cyclone and a barrier filter in addition to the syngas scrubber and the gas washing effect of the AGR absorber. Ninety-five percent of the Hg is captured from the syngas by an activated carbon bed.

A summary of the resulting air emissions for the Shell IGCC plant is presented in Table 3.

### Cost Estimation

Estimates of capital and operations costs were developed for each plant based on adjusted vendor-furnished and actual cost data from recent design/build projects. These costs were used to calculate a first year cost-of-electricity (COE) based on the power plant costs and assumed financing structure. Financial assumptions and a cost summary are shown in Table 4.

Project contingencies were added to each case to cover project uncertainty and the cost of any additional equipment that could result from detailed design. The project contingencies represent costs that are expected to occur. Project contingency was 11.1 percent of the Shell IGCC case Total Plant Cost (TPC).

Process contingency is intended to compensate for uncertainties arising as a result of the state of technology development. Process contingencies represent 2.3 percent of the Shell IGCC case TPC and have been applied to the estimates as follows:

- Gasifiers and Syngas Coolers – 15 percent on all IGCC cases
- Mercury Removal – 5 percent on all IGCC cases
- Combustion Turbine Generator – 5 percent on all IGCC cases without CCS
- Instrumentation and Controls – 5 percent on all IGCC cases

This study assumes that each new plant would be dispatched any time it is available and would be capable of generating maximum capacity when online. Therefore, CF is assumed to equal availability and is 80 percent for IGCC cases.

The 629 MWe (net) Shell IGCC plant was projected to have a Total Overnight Cost (TOC) of \$2,716/kWe, resulting in a COE of 81.3 mills/kWh.

**Table 3 Air Emissions Summary at 80% Capacity Factor**

Pollutant	Shell IGCC Without CCS
<b>CO<sub>2</sub></b>	
• million tonnes/year	3.189
• lb/MWh <sub>net</sub>	1,595
<b>SO<sub>2</sub></b>	
• tonne/year	68
• lb/MMBtu	0.0042
<b>NO<sub>x</sub></b>	
• tonne/year	957
• lb/MMBtu	0.059
<b>PM (filterable)</b>	
• tonne/year	115
• lb/MMBtu	0.0071
<b>Hg</b>	
• tonne/year	0.009
• lb/TBtu	0.571

Table 4 Major Financial Assumptions and Resulting Cost<sup>1</sup>

<b>Major Assumptions</b>			
Case:	<b>1x629 MWe net Shell IGCC</b>		
Plant Size:	629.0 (MWe, net)	Heat Rate:	8,099 (Btu/kWh)
Primary/Secondary Fuel (type):	Illinois No. 6 Coal	Fuel Cost:	1.64 (\$/MMBtu)
Capital Expenditure Period:	5 (years)	Plant Life:	30 (years)
Cost Basis Year:	2007 (June)	Plant in Service:	2012 (June)
Capacity Factor:	80 (%)	Capital Charge Factor:	12.4 (%)
<b>Resulting Capital Investment (2007 dollars)</b>			<b>Mills/kWh</b>
Total Overnight Cost <sup>2</sup>			48.2
<b>Resulting Operating Costs (2007 dollars)<sup>3</sup></b>			<b>Mills/kWh</b>
Fixed Operating Cost			12.1
Variable Operating Cost			7.8
<b>Resulting Fuel Cost (2007 dollars) at \$1.80 / MMBtu</b>			<b>Mills/kWh</b>
			13.3
<b>Total Busbar Cost of Power (2007 dollars)</b>			<b>Mills/kWh</b>
			81.3

<sup>1</sup>Costs shown can vary -15%/+30%.

<sup>2</sup>Total overnight cost includes all equipment (complete with initial chemical and catalyst loadings), materials, labor (direct and indirect), engineering and construction management, and contingencies (process and project), and owner's cost.

<sup>3</sup>No credit taken for by-product sales.

### Contacts

**James Black**  
 General Engineer  
 National Energy Technology Laboratory  
 626 Cochrans Mill Road  
 P.O. Box 10940  
 Pittsburgh, PA 15236  
 412-386-5458  
 james.black@netl.doe.gov

**Larry Rath**  
 Director of Performance Division  
 National Energy Technology Laboratory  
 626 Cochrans Mill Road  
 P.O. Box 10940  
 Pittsburgh, PA 15236  
 412-386-6871  
 larry.rath@netl.doe.gov

### References

Cost and Performance Baseline for Fossil Energy Plants, Vol. I. (2010, November). Pittsburgh, PA. DOE/NETL-2010/1397.

CoalFleet User Design Basis Specification for Coal-Based Integrated Gasification Combined Cycle (IGCC) Power Plants, (2009). EPRI, Palo Alto, CA. 1017501.

# Shell IGCC Plant With Carbon Capture and Sequestration

## Plant Overview

This analysis is based on a 497 MWe (net power output) Integrated Gasification Combined-Cycle (IGCC) plant using Shell Global Solutions gasification technology located at a greenfield site in the midwestern United States. The plant utilizes carbon capture and sequestration (CCS). Two pressurized, dry-feed, entrained-flow gasification trains feed two advanced F-Class combustion turbines. A quench reactor is utilized to provide a portion of the water required for the water gas shift. Two heat recovery steam generators (HRSG) and one steam turbine provide additional power. Carbon dioxide (CO<sub>2</sub>) is removed with the two-stage Selexol physical solvent process. The combination process and heat and mass balance diagram for the Shell IGCC plant with CCS is shown in Figure 1. The primary fuel is an Illinois No. 6 bituminous coal with a higher heating value (HHV) of 11,666 Btu/lb. The capacity factor (CF) for the plant is 80 percent without sparing of major train components. A summary of plant performance data for the Shell IGCC plant with CCS is presented in Table 1.

Table 1. Plant Performance Summary

Plant Type	Shell IGCC
Carbon capture	Yes
Net power output (kWe)	496,860
Net plant efficiency (%)	31.2
Primary fuel (type)	Illinois No. 6 coal
COE (mills/kWh) @ 80% CF	119.4
TPC/TOC (\$/kW)	3,181/3,904
Cost of CO <sub>2</sub> avoided <sup>1</sup> (\$/tonne)	61/86
Analogous/Supercritical PC Ref.	

<sup>1</sup>The avoided costs for each capture case are calculated using the analogous non-capture plant as the reference and again with SC PC without CO<sub>2</sub> capture as the reference.

Figure 1. Process Flow Diagram Shell IGCC with CCS

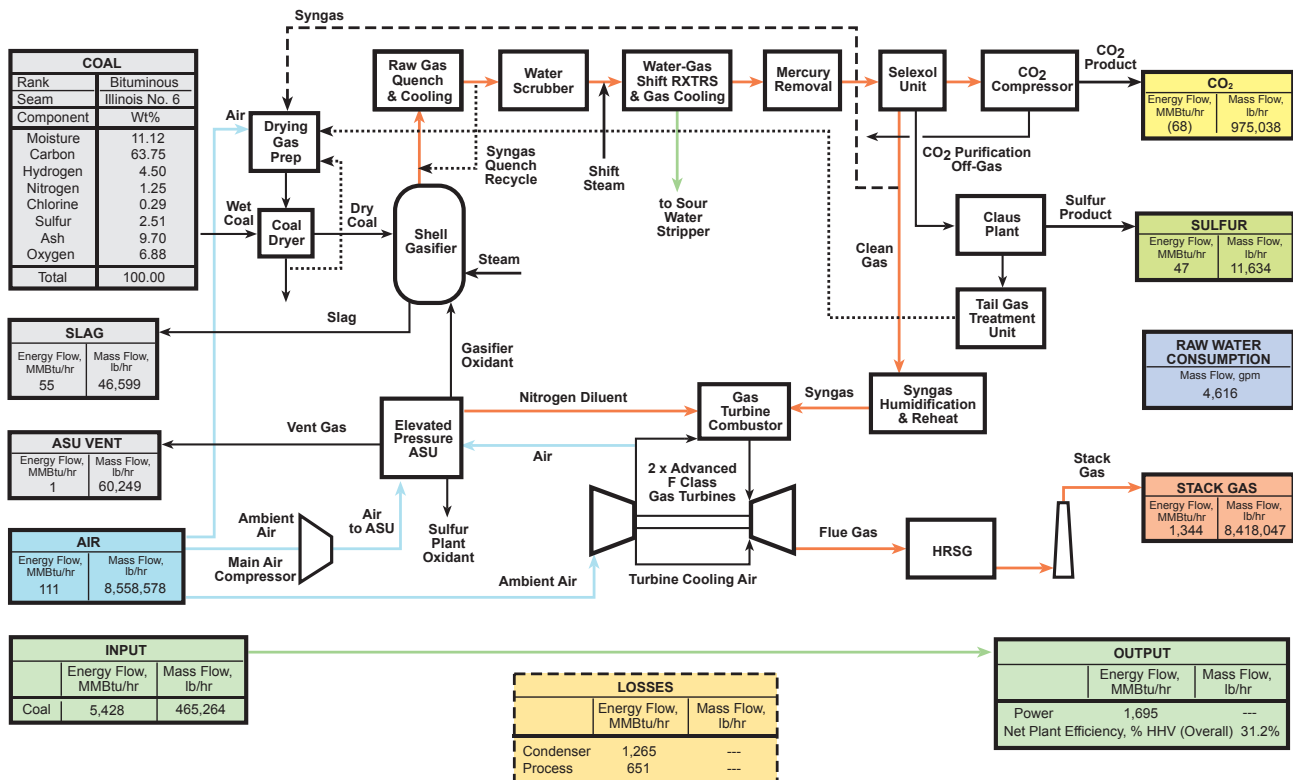

Note: Diagram is provided for general reference of major flows only. For complete flow information, please refer to the final report.

## Technical Description

The plant uses the Shell gasification technology. All technology selected for the plant design is assumed to be available to facilitate a 2012 startup date for a newly constructed plant. However, because certain processes like the combustion turbine operating on a high-hydrogen content syngas and the two-stage Selexol process for CO<sub>2</sub> capture either have no commercial or limited commercial operating experience, a process contingency was included in this case.

Two gasification trains process a total of 5,065 tonnes of coal per day. Dry coal is introduced to the gasifier via lockhoppers. Oxygen (O<sub>2</sub>) is produced in a cryogenic air separation unit. Coal, steam, and O<sub>2</sub> react in the gasifier at about 4.2 MPa (615 psia) at a temperature of 1,427°C (2,600°F) to produce syngas. The gas from the gasifier is quenched to 399°C (750°F) with water to provide a portion of the water required for water-gas-shift (WGS) reactions. The syngas passes through a cyclone and a raw gas candle filter where a majority of the fine particles are removed. The ash that is not carried out with the gas forms slag and runs down the interior walls, exiting the gasifier in liquid form.

The raw syngas is cooled to 260°C (500°F) and then enters a scrubber for removal of chlorides and remaining particulate matter (PM). Following the scrubber, the raw syngas is reheated to 285°C (545°F) and fed through two sour gas shift reactors for converting carbon monoxide (CO) to CO<sub>2</sub> and also hydrolyzing Carbonyl Sulfide (COS), eliminating the need for a separate COS hydrolysis reactor. The syngas is then cooled to about 35°C (95°F) before passing through a carbon bed to remove ninety-five percent of the Hg.

To capture CO<sub>2</sub>, a WGS reactor containing a series of two shifts with inter-cooled stages converts a nominal 96 percent of the CO to CO<sub>2</sub>. Carbon dioxide is removed from the cool, particulate-free gas stream with Selexol solvent. The dual-absorber Selexol acid gas removal (AGR) process preferentially removes hydrogen sulfide (H<sub>2</sub>S) as a product stream, leaving CO<sub>2</sub> as a separate product stream. Elemental sulfur is recovered in a Claus bypass-type sulfur recovery unit utilizing oxygen instead of air. The CO<sub>2</sub> is dried and compressed to 15.3 MPa (2,215 psia) for subsequent pipeline transport and sequestration. The compressed CO<sub>2</sub> is transported via pipeline to a geologic sequestration field for injection into a saline aquifer, which is located within 50 miles of the plant.

A Brayton cycle, fueled by the syngas, is used in conjunction with a conventional subcritical steam Rankine cycle for combined cycle power generation. The two cycles are integrated by generation of steam in the HRSGs, by feedwater heating in the HRSGs, and by heat recovery from the IGCC process. The steam turbine operates at 12.4 MPa/538°C/538°C (1,800 psig/1,000 °F/1,000°F). The plant produces a net output of 497 MWe. The summary of plant electrical generation performance is presented in Table 2. This plant configuration results in a net plant efficiency of 31.2 percent (HHV basis), or a net plant heat rate of 10,924 Btu/kWh.

**Table 2. Plant Electrical Generation**

	Electrical Summary
Advanced gas turbine x 2, MWe	464.0
Steam turbine, MWe	209.4
Gross power output, MWe	673.4
Auxiliary power requirement, MWe	(176.5)
Net power output, MWe	496.9

## Environmental Performance

The environmental specifications for a greenfield IGCC plant are based on the Electric Power Research Institute *CoalFleet User Design Basis for Coal-Based IGCC Plants* specification. Low sulfur dioxide (SO<sub>2</sub>) emissions (less than 3 ppmv in the flue gas) are achieved by capture of the sulfur in the two-stage Selexol acid gas removal (AGR)

process, which removes over 99 percent of the sulfur in the fuel gas. The resulting H<sub>2</sub>S-rich regeneration gas from the AGR system is fed to a Claus plant, producing elemental sulfur. Nitrogen oxides (NO<sub>x</sub>) emissions are limited by nitrogen dilution (primarily) and syngas humidification (secondarily) in the gas turbine combustor to 15 ppmvd (as nitrogen oxide at 15 percent O<sub>2</sub>). Filterable PM discharge to the atmosphere is limited to extremely low values by the use of a cyclone and a barrier filter in addition to the syngas scrubber and the gas-washing effect of the AGR absorber. Ninety-five percent of the Hg is captured from the syngas by an activated carbon bed. Approximately 90 percent of the CO<sub>2</sub> from the syngas is captured in the AGR system and compressed for pipeline transport and sequestration.

A summary of the resulting air emissions for the Shell IGCC plant with CCS is presented in Table 3.

### Cost Estimation

Estimates of capital and operations costs were developed for each plant based on adjusted vendor-furnished and actual cost data from recent design/build projects. These costs were used to calculate a first year cost-of-electricity (COE) based on the power plant costs and assumed financing structure. Financial assumptions and a cost summary are shown in Table 4.

Project contingencies were added to the case to cover project uncertainty and the cost of any additional equipment that could result from detailed design. The project contingencies represent costs that are expected to occur. Project contingency was 11.4 percent of the Shell IGCC with CCS case Total Plant Cost (TPC) COE.

Process contingency is intended to compensate for uncertainties arising as a result of the state of technology development. Process contingencies represent 3.4 percent of the Shell IGCC with CCS case TPC and have been applied to the estimates as follows:

- Gasifiers and Syngas Coolers – 15 percent on all IGCC cases
- Two Stage Selexol – 20 percent on all IGCC CCS cases
- Mercury Removal – 5 percent on all IGCC cases
- Combustion Turbine Generator – 10 percent on all IGCC cases with CCS
- Instrumentation and Controls – 5 percent on all IGCC cases

This study assumes that each new plant would be dispatched any time it is available and would be capable of generating maximum capacity when online. Therefore, CF is assumed to equal availability and is 80 percent for IGCC cases.

The 496.9 (net) MWe Shell IGCC plant with CCS was projected to have a Total Overnight Cost (TOC) of \$3,904/kWe, resulting in a COE of 119.4 mills/kWh.

**Table 3. Air Emissions Summary at 80% Capacity Factor**

Pollutant	Shell IGCC with CCS (90%)
<b>CO<sub>2</sub></b>	
• million tonnes/year	0.345
• lb/MWh <sub>net</sub>	218
<b>SO<sub>2</sub></b>	
• tonne/year	37
• lb/MMBtu	0.0021
<b>NO<sub>x</sub></b>	
• tonne/year	847
• lb/MMBtu	0.049
<b>PM (filterable)</b>	
• tonne/year	123
• lb/MMBtu	0.0071
<b>Hg</b>	
• tonne/year	0.010
• lb/TBtu	0.571

Table 4. Major Financial Assumptions and Resulting Cost Summary<sup>1</sup>

<b>Major Assumptions</b>			
Case:	<b>1x497 MWe net Shell IGCC with CCS</b>		
Plant Size:	496.9 (MWe, net)	Heat Rate:	10,924 (Btu/kWh)
Primary/Secondary Fuel (type):	Illinois No. 6 Coal	Fuel Cost:	164 (\$/MMBtu)
Capital Expenditure Period:	5 (years)	Plant Life:	30 (years)
Cost Basis Year:	2007 (June)	Plant in Service:	2012 (June)
Capacity Factor:	80 (%)	Capital Charge Factor:	12.4 (%)
<b>Resulting Capital Investment (2007 dollars)</b>			<b>Mills/kWh</b>
Total Overnight Cost <sup>2</sup>			69.2
<b>Resulting Operating Costs (2007 dollars)<sup>3</sup></b>			<b>Mills/kWh</b>
Fixed Operating Cost			16.7
Variable Operating Cost			9.9
<b>Resulting Fuel Cost (2007 dollars) at \$1.80 / MMBtu</b>			<b>Mills/kWh</b>
			17.9
<b>Resulting CO<sub>2</sub> Cost (2007 dollars)</b>			<b>Mills/kWh</b>
			5.6
<b>Total Busbar Cost of Power (2007 dollars)</b>			<b>Mills/kWh</b>
			119.4

<sup>1</sup>Costs shown can vary-15%/+30%.

<sup>2</sup>Total overnight cost includes all equipment (complete with initial chemical and catalyst loadings), materials, labor (direct and indirect), engineering and construction management, and contingencies (process and project), and owner's cost.

<sup>3</sup>No credit taken for by-product sales.

### Contacts

**James Black**  
 General Engineer  
 National Energy Technology Laboratory  
 626 Cochrans Mill Road  
 P.O. Box 10940  
 Pittsburgh, PA 15236  
 412-386-5458  
 james.black@netl.doe.gov

**Larry Rath**  
 Director of Performance Division  
 National Energy Technology Laboratory  
 626 Cochrans Mill Road  
 P.O. Box 10940  
 Pittsburgh, PA 15236  
 412-386-6871  
 larry.rath@netl.doe.gov

### References

Cost and Performance Baseline for Fossil Energy Plants, Vol. I. (2010, November). Pittsburgh, PA. DOE/NETL-2010/1397.

CoalFleet User Design Basis Specification for Coal-Based Integrated Gasification Combined Cycle (IGCC) Power Plants, (2009). EPRI, Palo Alto, CA. 1017501.



# Pulverized Coal Plants With and Without Carbon Capture and Sequestration

## Technology Overview

Four pulverized coal (PC) Rankine cycle power plant configurations fired with bituminous coal were evaluated and the results are presented in this summary sheet. All cases were analyzed using a consistent set of assumptions and analytical tools. Each PC type was assessed with and without carbon capture and sequestration (CCS). The individual configurations are as follows:

- Subcritical PC plant
- Subcritical PC plant with CCS
- Supercritical PC plant
- Supercritical PC plant with CCS

Each PC plant design is based on a market-ready technology that is assumed to be commercially available in time to support a 2012 startup date. The PC plants are built at a greenfield site in the midwestern United States and are assumed to operate at 85 percent capacity factor (CF) without sparing of major train components. Nominal plant size (gross rating) is 580 MWe without CCS and 670 MWe with CCS. All designs employ a one-on-one configuration comprising a state-of-the-art PC steam generator and a steam turbine. The primary fuel is Illinois No. 6 bituminous coal with a higher heating value (HHV) of 11,666 Btu/lb. The boiler is a dry-bottom, wall-fired unit that employs low-nitrogen oxides burners (LNB) with over-fire air (OFA) and selective catalytic reduction (SCR) for nitrogen oxides (NO<sub>x</sub>) control, a wet-limestone forced-oxidation scrubber for sulfur dioxide (SO<sub>2</sub>) and mercury (Hg) control, and a fabric filter for particulate matter (PM) control.

The PC cases are evaluated with and without CCS on a common 550 MWe net basis. The designs that include CCS are equipped with the Fluor Econamine Flue Gas (FG) Plus™ process. The CCS cases have a larger gross electrical output to compensate for the higher auxiliary loads. After compression to pipeline specification pressure, the carbon dioxide (CO<sub>2</sub>) is assumed to be transported to a nearby underground storage facility for sequestration. The boiler and steam turbine industry ability to match unit size to a custom specification has been commercially demonstrated, enabling common net output comparison of the PC cases in this study.

See Figure 1 for a generic block flow diagram of a PC plant. The orange blocks in the figure represent the unit operations added to the configuration for CCS cases.

**Figure 1. Pulverized Coal Power Plant**

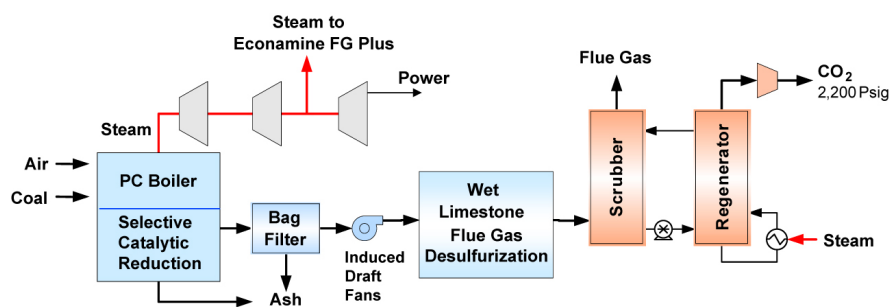

**Particulate matter control:** Baghouse achieves 0.013 lb/MMBtu (99.8% removal).

**Sulfur oxides control:** FGD to achieve 0.085 lb/MMBtu (98% removal).

**Nitrogen oxides control:** LNB + OFA + SCR to maintain 0.07 lb/MMBtu emissions limit.

**Carbon dioxide control:** Fluor Econamine FG Plus™ (90% removal).

**Hg control:** Co-benefit capture for ~90% removal.

**Subcritical steam conditions:**  
2,400 psig/1,050°F/1,050°F.

**Supercritical steam conditions:**  
3,500 psig/1,100°F/1,100°F.

Orange blocks indicate unit operations added for CCS Case.

Note: Diagram is provided for general reference of major flows only. For complete flow information, please refer to the final report.

## Technical Description

Steam conditions for the Rankine cycle cases are based on input from the original boiler and steam turbine equipment manufacturers (OEM) input on the most advanced steam conditions they would guarantee for a commercial project in the United States with PC units rated at nominal 550 MWe net capacity firing Illinois No. 6 coal. The input from the OEMs resulted in the following single-reheat steam conditions:

- For subcritical cases – 16.5 MPa/566°C/566°C (2,400 psig/1,050°F/1,050°F).
- For supercritical cases – 24.1 MPa/593°C/593°C (3,500 psig/1,100°F/1,100°F).

Recirculating evaporative cooling systems are used for cycle heat rejection. The average efficiency of the cases without CCS is 38 percent (HHV basis) for a plant with an average nominal gross rating of 582 MWe.

The CCS cases require a significant amount of auxiliary power and extraction steam for the process, which reduces the output of the steam turbine. This requires a higher nominal gross plant output for the CCS cases of an average of 668 MWe for an average net plant efficiency of 27 percent (HHV basis).

The designs that include CCS are equipped with the Fluor Econamine FG Plus™ technology, which removes 90 percent of the CO<sub>2</sub> in the flue gas exiting the flue gas desulfurization (FGD) unit. Once captured, the CO<sub>2</sub> is dried and compressed to 15.3 MPa (2,215 psia). The compressed CO<sub>2</sub> is transported via pipeline to a geologic sequestration field for injection into a saline aquifer, which is located within 50 miles of the plant. Carbon dioxide transport, storage, and monitoring (TS&M) costs are included in the analyses.

### Fuel Analysis and Costs

The design coal characteristics are presented in Table 1. All PC cases were modeled with Illinois No. 6 coal.

A cost of \$1.64/MMBtu (June 2007 dollars) was determined from the Energy Information Administration AEO2008 for an eastern interior high-sulfur bituminous coal.

### Environmental Design Basis

The environmental approach for this study was to evaluate each of the PC cases on the same regulatory design basis. The environmental specifications for a greenfield PC plant are based on Best Available Control Technology (BACT), which exceed New Source Performance Standard (NSPS) requirements. Table 2 provides details of the environmental design basis for PC plants built at a midwestern U.S. location. The emissions controls assumed for each of the four PC cases are as follows:

- A wet-limestone FGD system was used for sulfur control and also provided co-benefit Hg removal
- Low-NOx burners with OFA in conjunction with an SCR unit were used for NOx control

**Table 1. Fuel Analysis**

Rank	Bituminous	
Seam	Illinois No. 6 (Herrin)	
Source	Old Ben Mine	
Proximate Analysis (weight %) <sup>1</sup>		
	As received	Dry
Moisture	11.12	0.00
Ash	9.70	10.91
Volatile matter	34.99	39.37
Fixed carbon	44.19	49.72
<b>Total</b>	<b>100.00</b>	<b>100.00</b>
Sulfur	2.51	2.82
Higher heating value, Btu/lb	11,666	13,126
Lower heating value, Btu/lb	11,252	12,712

<sup>1</sup>The above proximate analysis assumes sulfur as a volatile matter.

**Table 2. Environmental Targets**

Pollutant	PC <sup>1</sup>
SO <sub>2</sub>	0.085 lb/MMBtu
NOx	0.07 lb/MMBtu
PM (filterable)	0.013 lb/MMBtu
Hg	1.14 lb/TBtu

<sup>1</sup>Based on BACT and NSPS.

- Fabric filter was used for PM control
- Econamine FG Plus™ was used for CO<sub>2</sub> capture in the CCS cases

**Major Economic and Financial Assumptions**

For the PC cases, estimates of capital and operations costs were developed for each plant based on adjusted vendor-furnished and actual cost data from recent design/build projects. These costs were used to calculate a first year cost-of-electricity (COE) based on the power plant costs and assumed financing structure. Listed in Table 3 are the major economic and financial assumptions for the four PC cases.

Project contingencies were added to each of the cases to cover project uncertainty and the cost of any additional equipment that could result from detailed design. The project contingencies represent costs that are expected to occur. Project contingency was about 8.9 percent for the PC cases without CCS and roughly 10.2 percent for the PC cases with CCS.

Process contingency is intended to compensate for uncertainties arising as a result of the state of technology development. Process contingencies have been applied to the estimates as follows:

- CO<sub>2</sub> Removal System – 20 percent on all PC CCS cases
- Instrumentation and Controls – 5 percent on the PC CCS cases

This study assumes that each new plant would be dispatched any time it is available and would be capable of generating maximum capacity when online. Therefore, CF is assumed to equal availability and is 85 percent for PC cases.

For the PC cases that feature CCS, capital and operating costs were estimated for transporting CO<sub>2</sub> to an underground storage field, associated storage in a saline aquifer, and for monitoring beyond the expected life of the plant.

**Results**

An analysis of the four PC cases is presented in the following sections.

**Capital Cost**

Total Overnight Cost (TOC) for each of the four PC cases is compared in Figure 2. The TOC includes all equipment (complete with initial chemical and catalyst loadings), materials, labor (direct and indirect), engineering and construction management, and contingencies (process and project), and owner’s cost. Interest during construction and escalation during construction are not included as owner’s costs but are factored into the COE and are included in Total As-spent Cost (TASC).

**Table 3. Major Economic and Financial Assumptions for PC Cases**

Major Economic Assumptions	
Capacity factor	85%
Costs per year, constant U.S. dollars	2007 (June)
Illinois No. 6 delivered cost	\$1.64/MMBtu
Capital Expenditure Period	5 years
Plant startup date	2010 (June)
Major Financial Assumptions	
Depreciation	20 years
Federal income tax	34%
State income tax	6%
Low risk cases	
After-tax weighted cost of capital	7.39%
Capital structure:	
Common equity	50% (Cost = 12%)
Debt	50% (Cost = 9%)
Capital charge factor	11.6%
High risk cases	
After-tax weighted cost of capital	8.13%
Capital structure:	
Common equity	55% (Cost = 12%)
Debt	45% (Cost = 11%)
Capital charge factor	12.4%

Figure 2. Comparison of TOC for the Four PC Cases

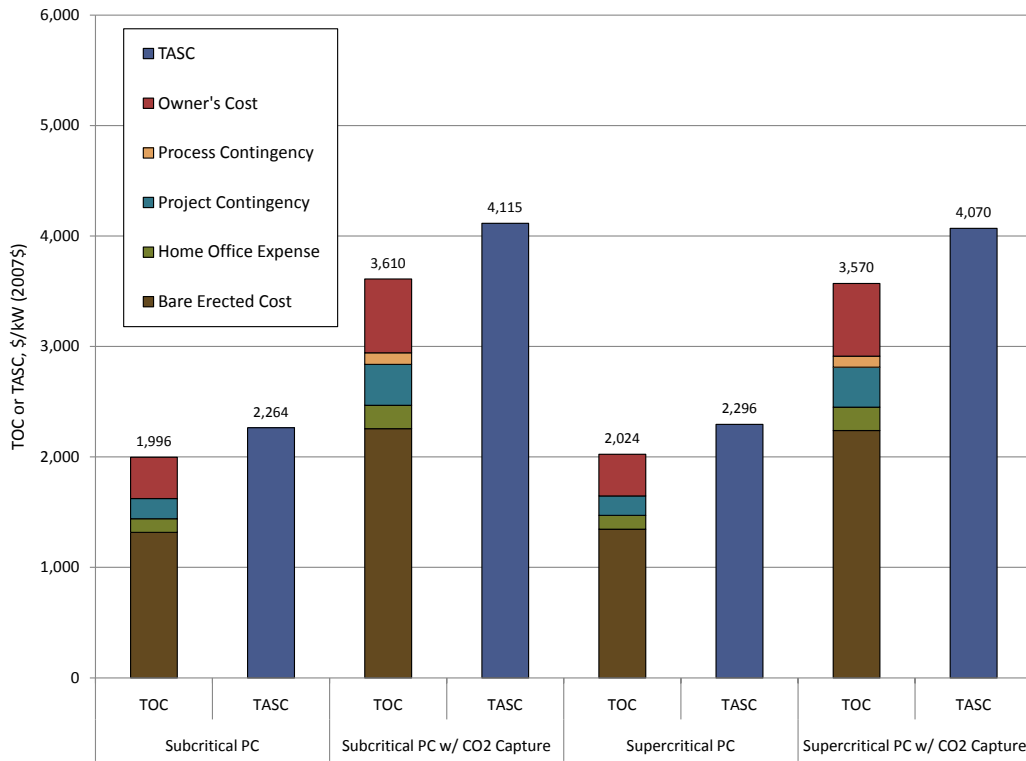

The results of the analysis indicate that the supercritical PC cases and the subcritical PC cases are nearly the same capital cost. With CCS, the TOC increases by roughly 79 percent for both subcritical and supercritical cases, resulting in very similar capital costs averaging \$3,590/kWe.

Figure 3. Comparison of Net Plant Efficiency for the Four PC Cases

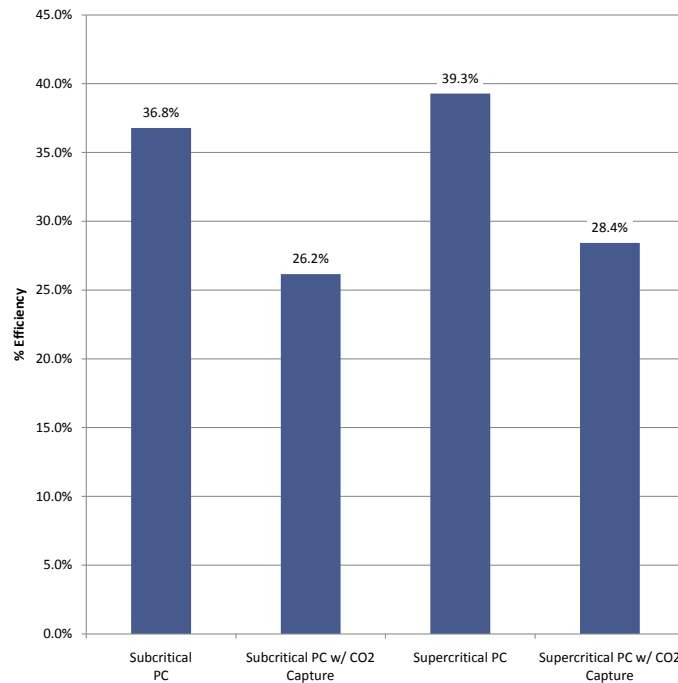

**Efficiency**

The net plant efficiencies for the four PC cases are compared in Figure 3. This analysis indicates that the supercritical plant efficiency of 39.3 percent (HHV basis) is 2.5 percentage points higher than the subcritical case. With CCS, the efficiency penalty is about a 10 percentage point drop in both subcritical and supercritical plants, resulting in an efficiency of about 26 percent (HHV basis) for the subcritical case, with the supercritical case being about 2 percentage points higher.

**Figure 4. Comparison of Cost-of-Electricity for the Four PC Cases**

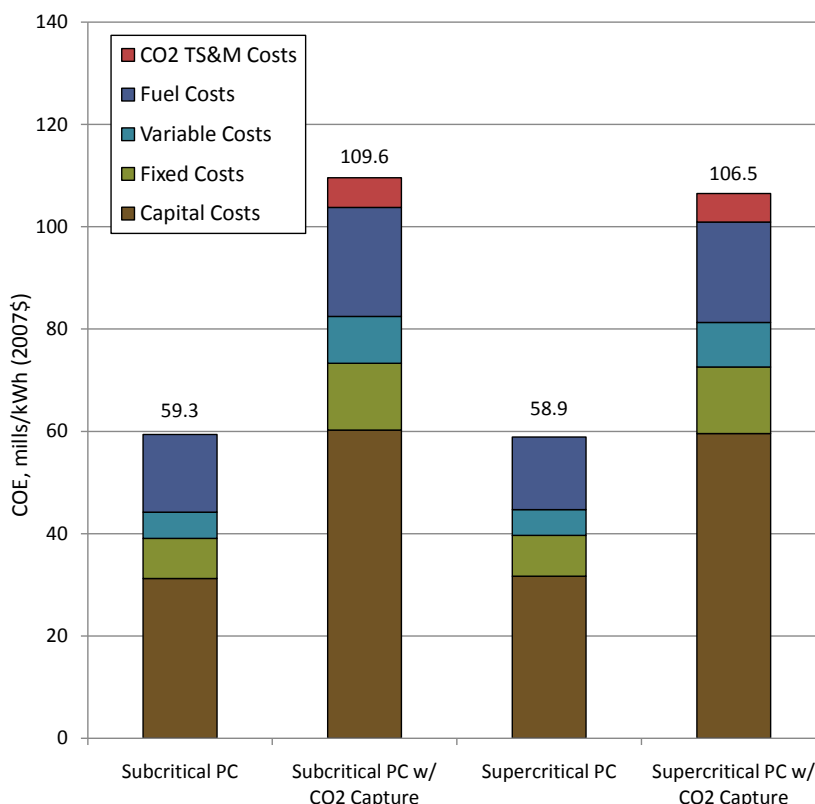

**Cost-of-Electricity**

The COE is a measurement of the coal-to-busbar cost of power, and includes the TOC, fixed and variable operating costs, and fuel costs. The calculated cost of TS&M for CO<sub>2</sub> adds roughly 4 mills/kWh to the COE.

The PC plants generate power at an COE of about 59 mills/kWh at a CF of 85 percent. When CCS is included, the increased Total Plant Cost (TPC) and reduced efficiency result in a higher COE of roughly 108 mills/kWh.

**Environmental Impacts**

Table 4 provides a comparative summary of emissions from the four PC cases. Mass emission rates and cumulative annual totals are given for SO<sub>2</sub>, NO<sub>x</sub>, PM, Hg, and CO<sub>2</sub>. Additionally, plant water usage is shown.

The emissions from all four PC cases evaluated meet or exceed BACT and NSPS requirements. The CO<sub>2</sub> is reduced by 90 percent in the capture cases. The cost of CO<sub>2</sub> avoided is about \$75/tonne. The cost of CO<sub>2</sub> avoided is defined as the difference in the COE between controlled and uncontrolled like cases, divided by the difference in CO<sub>2</sub> emissions in kg/MWh. Raw water usage in the CCS cases is more than twice that of the cases without CCS primarily because of the large cooling water demand of the Econamine FG Plus™ process.

Table 4. Air Emissions Summary at 85% Capacity Factor

Pollutant	Pulverized Coal Boiler			
	PC Subcritical		PC Supercritical	
	Without CCS	With CCS (90%)	Without CCS	With CCS (90%)
<b>CO<sub>2</sub></b>				
• million tonnes/year	3,508	0.493	3,284	0.454
• lb/MWh <sub>net</sub>	1,888	266	1,768	244
• Cost of CO <sub>2</sub> avoided <sup>1</sup> (\$/tonne) Analogous/Supercritical PC Ref	—	68/75	—	69/69
<b>SO<sub>2</sub></b>				
• tonne/year	1,479	40	1,385	36
• lb/MMBtu	0.0858	0.0017	0.0858	0.0016
<b>NO<sub>x</sub></b>				
• tonne/year	1,206	1,696	1,130	36
• lb/MMBtu	0.070	0.070	0.070	0.070
<b>PM (filterable)</b>				
• tonne/year	224	315	210	290
• lb/MMBtu	0.0130	0.0130	0.0130	0.0130
<b>Hg</b>				
• tonne/year	0.020	0.028	0.018	0.025
• lb/TBtu	1.143	1.143	1.143	1.143
<b>Raw water consumption, gpm</b>	4,680	8,620	4,227	7,733

### Contacts

**James Black**

General Engineer  
 National Energy Technology Laboratory  
 626 Cochrans Mill Road  
 P.O. Box 10940  
 Pittsburgh, PA 15236  
 412-386-5458  
 james.black@netl.doe.gov

**Larry Rath**

Director of Performance Division  
 National Energy Technology Laboratory  
 626 Cochrans Mill Road  
 P.O. Box 10940  
 Pittsburgh, PA 15236  
 412-386-6871  
 larry.rath@netl.doe.gov

References

- Cost and Performance Baseline for Fossil Energy Plants, Vol. 1. (2010, November). Pittsburgh, PA. DOE/NETL-2010/1397.
- CoalFleet User Design Basis Specification for Coal-Based Integrated Gasification Combined Cycle (IGCC) Power Plants, (2009). EPRI, Palo Alto, CA. 1017501.

# Subcritical Pulverized Coal Plant

## Plant Overview

This analysis is based on a 550 MWe (net power output) subcritical bituminous pulverized coal (PC) plant located at a greenfield site in the midwestern United States.

This plant is designed to meet Best Available Control Technology (BACT) emission limits. The plant is a single-train design. The combination process, heat, and mass balance diagram for the subcritical PC plant is shown in Figure 1. The primary fuel is an Illinois No. 6 bituminous coal with a higher heating value (HHV) of 11,666 Btu/lb.

The capacity factor (CF) for the plant is 85 percent without sparing of major train components. A summary of plant performance data for the subcritical PC plant is presented in Table 1.

Table 1. Plant Performance Summary

Plant Type	PC Subcritical
Carbon capture	No
Net power output (kWe)	550,020
Net plant efficiency (%)	36.8%
Primary fuel (type)	Illinois No. 6 coal
COE (mills/kWh) @ 85% CF	59.4
TPC/TOC (\$/kW)	1,622/1,996

Figure 1. Process Flow Diagram Subcritical Pulverized Coal Unit

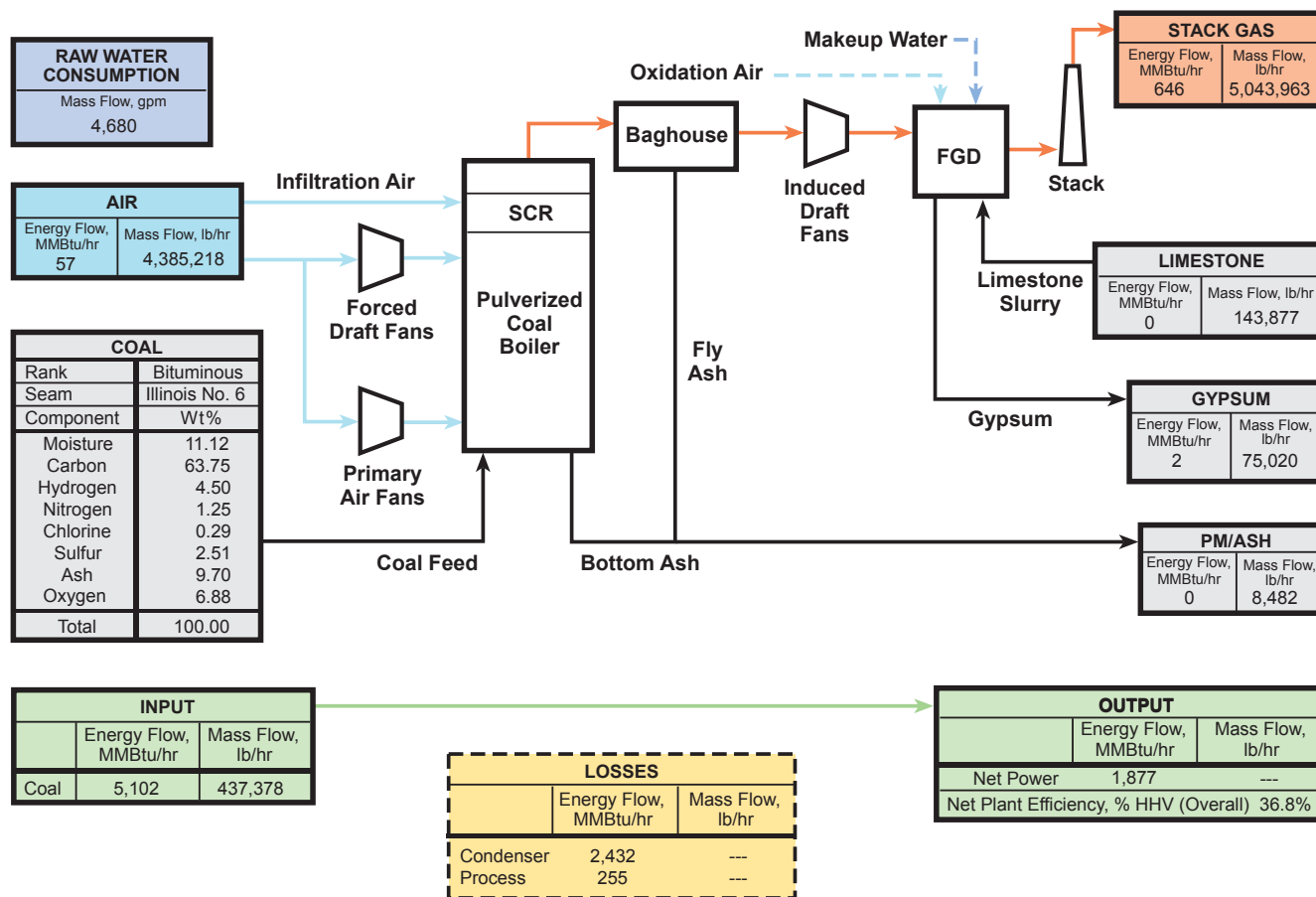

Note: Diagram is provided for general reference of major flows only. For complete flow information, please refer to the final report.

## Technical Description

The analysis for the subcritical PC plant is based on a commercially available dry-bottom, wall-fired boiler equipped with low-nitrogen oxides burners (LNB) and over-fire air (OFA). The unit is a balanced-draft, natural-circulation design equipped with a superheater, reheater, economizer, and air preheater. Hot flue gas exiting the boiler is treated by a selective catalytic reduction (SCR) unit for nitrogen oxides (NO<sub>x</sub>) removal, a baghouse for particulate matter (PM) removal, and a limestone-based scrubber for sulfur dioxide (SO<sub>2</sub>) control and co-removal of mercury (Hg). This plant utilizes a conventional steam turbine for power generation. The Rankine cycle is based on a single reheat system with steam conditions of 16.5 MPa/566°C/566°C (2,400 psig/1,050°F/1,050°F).

Achieving a nominal 550 MWe net output with this plant configuration results in a thermal input requirement of 1,495 kWt. This thermal input is achieved by burning coal at a rate of 437,378 lb/hr, which yields a net plant heat rate of 9,277 Btu/kWh (a net plant efficiency of 36.8 percent). The gross power output of 583 MWe is produced from the steam turbine generator. With an auxiliary power requirement of 33 MWe, the net plant output is 550 MWe.

## Environmental Performance

This study assumes the use of BACT to meet the emission requirements of the 2006 New Source Performance Standards.

The subcritical PC plant emission control strategy consists of a wet-limestone, forced-oxidation scrubber that achieves a 98 percent removal of SO<sub>2</sub>. The byproduct, calcium sulfate, is dewatered and stored onsite. The wallboard-grade material potentially can be marketed and sold, but since it is highly dependent on local market conditions, no byproduct credit is taken. The combination of SCR, a fabric filter, and wet scrubber also provides co-benefit. Hg capture at an assumed 90 percent of the inlet value. The saturated flue gas exiting the scrubber is vented through the plant stack. NO<sub>x</sub> emissions are controlled through the use of LNBS and OFA. An SCR unit then further reduces the NO<sub>x</sub> concentration by 86 percent. Particulate emissions are controlled using a pulse jet fabric filter, which operates at an efficiency of 99.8 percent.

A summary of the resulting air emissions is presented in Table 2.

**Table 2. Air Emissions Summary at 85% Capacity Factor**

Pollutant	PC Subcritical Without CCS
<b>CO<sub>2</sub></b>	
• million tonnes/year	3,508
• lb/MWh <sub>net</sub>	1,888
<b>SO<sub>2</sub></b>	
• tonne/year	1,479
• lb/MMBtu	0.086
<b>NO<sub>x</sub></b>	
• tonne/year	1,206
• lb/MMBtu	0.070
<b>PM</b>	
• tonne/year	224
• lb/MMBtu	0.013
<b>Hg</b>	
• tonne/year	0.020
• lb/TBtu	1.143

## Cost Estimation

Estimates of capital and operations costs were developed for each plant based on adjusted vendor-furnished and actual cost data from recent design/build projects. These costs were used to calculate a first year cost-of-electricity (COE) based on the power plant costs and assumed financing structure. Financial assumptions and a cost summary are shown in Table 3.

Project contingencies were added to each case to cover project uncertainty and the cost of any additional equipment that could result from detailed design. The project contingencies represent costs that are expected to occur. Project contingency was 9.1 percent of the subcritical PC case without CCS Total Plant Cost (TPC).



No process contingency is included in this case because all elements of the technology are commercially proven.

This study assumes that each new plant would be dispatched any time it is available and would be capable of generating maximum capacity when online. Therefore, CF is assumed to equal availability and is 85 percent for PC cases.

The 550 MWe (net) subcritical PC plant is projected to have a Total Overnight Cost (TOC) of \$1,996/kWe, resulting in a COE of 59.4 mills/kWh.

**Table 3. Major Financial Assumptions and Resulting Cost Summary<sup>1</sup>**

<b>Major Assumptions</b>			
Case:	<b>1x550 MWe net Subcritical PC</b>		
Plant Size:	550.0 (MWe, net)	Heat Rate:	9,277 (Btu/kWh)
Primary/Secondary Fuel (type):	Illinois No. 6 Coal	Fuel Cost:	1.64 (\$/MMBtu)
Capital Expenditure Period:	5 (years)	Plant Life:	30 (years)
Cost Basis Year:	2007 (June)	Plant in Service:	2012 (June)
Capacity Factor:	85 (%)	Capital Charge Factor:	11.6 (%)
<b>Resulting Capital Investment (2007 dollars)</b>			<b>Mills/kWh</b>
Total Overnight Cost <sup>2</sup>			31.2
<b>Resulting Operating Costs (2007 dollars)<sup>3</sup></b>			<b>Mills/kWh</b>
Fixed Operating Cost			7.8
Variable Operating Cost			5.1
<b>Resulting Fuel Cost (2007 dollars) at \$1.80 / MMBtu</b>			<b>Mills/kWh</b>
			15.2
<b>Total Busbar Cost of Power (2007 dollars)</b>			<b>Mills/kWh</b>
			59.4

<sup>1</sup>Costs shown can vary -15%/+30%.

<sup>2</sup>Total overnight cost includes all equipment (complete with initial chemical and catalyst loadings), materials, labor (direct and indirect), engineering and construction management, and contingencies (process and project), and owner's cost.

<sup>3</sup>No credit taken for by-product sales.

### Contacts

**James Black**

General Engineer  
National Energy Technology Laboratory  
626 Cochrans Mill Road  
P.O. Box 10940  
Pittsburgh, PA 15236  
412-386-5458  
james.black@netl.doe.gov

**Larry Rath**

Director of Performance Division  
National Energy Technology Laboratory  
626 Cochrans Mill Road  
P.O. Box 10940  
Pittsburgh, PA 15236  
412-386-6871  
larry.rath@netl.doe.gov

#### References

Cost and Performance Baseline for Fossil Energy Plants, Vol. 1. (2010, November). Pittsburgh, PA. DOE/NETL-2010/1397.

CoalFleet User Design Basis Specification for Coal-Based Integrated Gasification Combined Cycle (IGCC) Power Plants, (2009). EPRI, Palo Alto, CA. 1017501.

# Subcritical Pulverized Coal Plant With Carbon Capture and Sequestration

## Plant Overview

This analysis is based on a 550 MWe (net power output) subcritical bituminous pulverized coal (PC) plant located at a greenfield site in the midwestern United States. This plant captures carbon dioxide (CO<sub>2</sub>) to be sequestered and is designed to meet Best Available Control Technology (BACT) emission limits. The plant is a single-train design. The combination process, heat, and mass balance diagram for the subcritical PC plant with carbon capture and sequestration (CCS) case is shown in Figure I. The primary fuel is an Illinois No. 6 bituminous coal with a higher heating value (HHV) of 11,666 Btu/lb. The capacity factor (CF) for the plant is 85 percent without sparing of major train components. A summary of plant performance data for the subcritical PC plant with CCS is presented in Table I.

Table I. Plant Performance Summary

Plant Type	PC Subcritical
Carbon capture	Yes
Net power output (kWe)	549,960
Net plant efficiency (%)	26.2
Primary fuel (type)	Illinois No. 6 coal
COE (mills/kWh) @ 85% CF	109.6
TPC/TOC (\$/kW)	2,942/3,610
Cost of CO <sub>2</sub> avoided <sup>1</sup> (\$/tonne)	68/75
Analogous/Supercritical PC Ref.	

<sup>1</sup>The avoided costs for each capture case are calculated using the analogous non-capture plant as the reference and again with SC PC without CO<sub>2</sub> capture as the reference.

Figure I. Process Flow Diagram  
Subcritical Pulverized Coal Unit With CCS

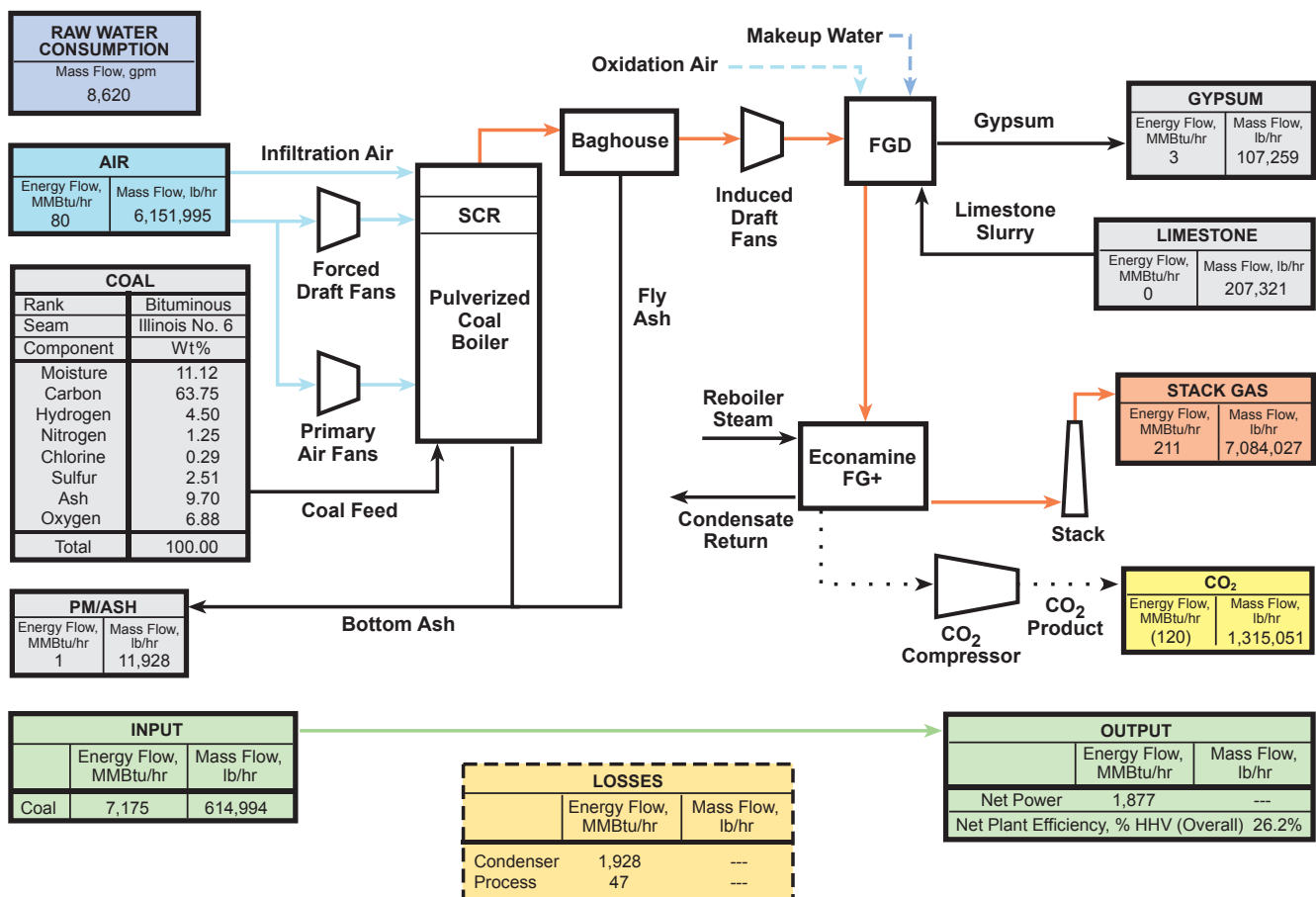

Note: Diagram is provided for general reference of major flows only. For complete flow information, please refer to the final report.

## Technical Description

The analysis for the subcritical PC plant with CCS is based on a commercially available dry-bottom, wall-fired boiler equipped with low-nitrogen oxides (NOx) burners (LNB) and over-fire air (OFA). The unit is a balanced-draft, natural-circulation design equipped with a superheater, reheater, economizer, and air preheater. Hot flue gas (FG) exiting the boiler is treated by a selective catalytic reduction (SCR) unit for NOx removal, a baghouse for particulate matter (PM) removal, and a limestone-based scrubber for sulfur dioxide (SO<sub>2</sub>) control and co-removal of mercury (Hg). This plant utilizes a conventional steam turbine for power generation. The Rankine cycle is based on a single reheat system with steam conditions of 16.5 MPa/566°C/566°C (2,400 psig/1,050°F/1,050°F).

This subcritical PC plant with CCS is equipped with the Fluor Econamine FG Plus™ technology for carbon capture. Flue gas exiting the scrubber system is directed to the Econamine FG Plus™ process where CO<sub>2</sub> is absorbed in a monethanolamine-based solvent. A booster blower is required to overcome the process pressure drop. Carbon dioxide recovered in the Econamine FG Plus™ process is dried, compressed, and delivered to the plant fence line at 15.3 MPa (2,215 psia) for subsequent pipeline transport. The compressed CO<sub>2</sub> is transported via pipeline to a geologic sequestration field for injection into a saline aquifer, which is located within 50 miles of the plant.

Achieving a nominal 550 MWe net output with this plant configuration results in a thermal input requirement of 2,103 MWt. This thermal input is achieved by burning coal at a rate of 614,994 lb/hr, which yields a net plant heat rate of 13,046 Btu/kWh (net plant efficiency of 26.2 percent). The gross power output of 672 MWe is produced from the steam turbine generator. With an auxiliary power requirement of 123 MWe, the net plant output is 550 MWe. The Econamine FG Plus™ process imposes a significant auxiliary power load on the system, which requires this case to have a higher gross output, as compared with the subcritical without CCS case, to maintain the same 550 MWe net output.

## Environmental Performance

This study assumes the use of BACT to meet the emission requirements of the 2006 New Source Performance Standard for criteria pollutants.

The subcritical PC plant with CCS has an emission control strategy consisting of LNBS with OFA and SCR for NOx control, a pulse jet fabric filter for PM control, and a wet-limestone, forced-oxidation scrubber for SO<sub>2</sub> control. After NOx emissions are initially controlled through the use of LNBS and OFA, an SCR unit is used to further reduce the NOx concentration by 86 percent. Particulate emissions are controlled using a pulse jet fabric filter, which operates at an efficiency of 99.8 percent. The wet-limestone, forced-oxidation scrubber achieves a 98 percent removal of SO<sub>2</sub>. A polishing scrubber included as part of the Econamine FG Plus™ process further reduces the SO<sub>2</sub> concentration to less than 10 ppmv. The balance of the SO<sub>2</sub> is removed in the Econamine absorber resulting in negligible SO<sub>2</sub> emissions. The byproduct from the wet-limestone scrubber calcium sulfate is dewatered and stored onsite. The wallboard-grade material potentially can be marketed and sold, but since it is highly dependent on local market conditions, no byproduct credit is taken. The combination of SCR, a fabric filter, and wet scrubber also

**Table 2. Air Emissions Summary at 85% Capacity Factor**

Pollutant	PC Subcritical With CCS (90%)
<b>CO<sub>2</sub></b>	
• million tonnes/year	0.493
• lb/MWh <sub>net</sub>	266
<b>SO<sub>2</sub></b>	
• tonne/year	40
• lb/MMBtu	0.002
<b>NOx</b>	
• tonne/year	1,696
• lb/MMBtu	0.070
<b>PM</b>	
• tonne/year	315
• lb/MMBtu	0.013
<b>Hg</b>	
• tonne/year	0.028
• lb/TBtu	1.143

provides co-benefit Hg capture at an assumed 90 percent of the inlet value. After leaving the Econamine FG Plus™ process, the flue gas is vented through the plant stack.

A summary of the resulting air emissions is presented in Table 2.

## Cost Estimation

Estimates of capital and operations costs were developed for each plant based on adjusted vendor-furnished and actual cost data from recent design/build projects. These costs were used to calculate a first year cost-of-electricity (COE) based on the power plant costs and assumed financing structure. Financial assumptions and a cost summary are shown in Table 3.

Project contingencies were added to each case to cover project uncertainty and the cost of any additional equipment that could result from detailed design. The project contingencies represent costs that are expected to occur. Project contingency was 10.2 percent of the subcritical PC CCS case Total Plant Cost (TPC).

Process contingency is intended to compensate for uncertainties arising as a result of the state of technology development. Process contingencies represent 2.9 percent of the subcritical PC CCS case TPC and have been applied to the estimates as follows:

- CO<sub>2</sub> Removal System – 20 percent on all PC CCS cases
- Instrumentation and Controls – 5 percent on the PC CCS cases

This study assumes that each new plant would be dispatched any time it is available and would be capable of generating maximum capacity when online. Therefore, CF is assumed to equal availability and is 85 percent for PC cases.

For the PC cases that feature CCS, capital and operating costs were estimated for transporting CO<sub>2</sub> to an underground storage area, associated storage maintenance, and for monitoring beyond the expected life of the plant.

The 550 (net) MWe subcritical PC plant with CCS was projected to have a Total Overnight Cost (TOC) of \$3,610/kWe, resulting in a COE of 109.6 mills/kWh.

Table 3. Major Financial Assumptions and Resulting Cost Summary<sup>1</sup>

<b>Major Assumptions</b>			
Case:	<b>1x550 MWe net Subcritical PC with CCS</b>		
Plant Size:	550.0 (MWe, net)	Heat Rate:	13,046 (Btu/kWh)
Primary/Secondary Fuel (type):	Illinois No. 6 Coal	Fuel Cost:	1.64 (\$/MMBtu)
Capital Expenditure Period:	5 (years)	Plant Life:	30 (years)
Cost Basis Year:	2007 (June)	Plant in Service:	2012 (June)
Capacity Factor:	85 (%)	Capital Charge Factor:	12.4 (%)
<b>Resulting Capital Investment (2007 dollars)</b>			<b>Mills/kWh</b>
Total Overnight Cost <sup>2</sup>			60.2
<b>Resulting Operating Costs (2007 dollars)<sup>3</sup></b>			<b>Mills/kWh</b>
Fixed Operating Cost			13.1
Variable Operating Cost			9.2
<b>Resulting Fuel Cost (2007 dollars) at \$1.80 / MMBtu</b>			<b>Mills/kWh</b>
			21.3
<b>Resulting CO<sub>2</sub> Cost (2007 dollars)</b>			<b>Mills/kWh</b>
			5.8
<b>Total Busbar Cost of Power (2007 dollars)</b>			<b>Mills/kWh</b>
			109.6

<sup>1</sup>Costs shown can vary -15%/+30%.

<sup>2</sup>Total overnight cost includes all equipment (complete with initial chemical and catalyst loadings), materials, labor (direct and indirect), engineering and construction management, and contingencies (process and project), and owner’s cost.

<sup>3</sup>No credit taken for by-product sales.

### Contacts

**James Black**  
 General Engineer  
 National Energy Technology Laboratory  
 626 Cochrans Mill Road  
 P.O. Box 10940  
 Pittsburgh, PA 15236  
 412-386-5458  
 james.black@netl.doe.gov

**Larry Rath**  
 Director of Performance Division  
 National Energy Technology Laboratory  
 626 Cochrans Mill Road  
 P.O. Box 10940  
 Pittsburgh, PA 15236  
 412-386-6871  
 larry.rath@netl.doe.gov

### References

Cost and Performance Baseline for Fossil Energy Plants, Vol. 1. (2010, November). Pittsburgh, PA. DOE/NETL-2010/1397.

CoalFleet User Design Basis Specification for Coal-Based Integrated Gasification Combined Cycle (IGCC) Power Plants, (2009). EPRI, Palo Alto, CA. 1017501.

# Supercritical Pulverized Coal Plant

## Plant Overview

This analysis is based on a 550 MWe (net power output) supercritical bituminous pulverized coal (PC) plant located at a greenfield site in the midwestern United States. This plant is designed to meet Best Available Control Technology (BACT) emission limits. The plant is a single-train design. The combination process, heat and mass balance diagram for the supercritical PC plant case is shown in Figure 1. The primary fuel is an Illinois No. 6 bituminous coal with a higher heating value (HHV) of 11,666 Btu/lb. The capacity factor (CF) for the plant is 85 percent without sparing of major train components. A summary of plant performance data for the supercritical PC plant is presented in Table 1.

Table 1. Plant Performance Summary

Plant Type	PC Supercritical
Carbon capture	No
Net power output (kWe)	549,990
Net plant efficiency (%)	39.3
Primary fuel (type)	Illinois No. 6 coal
COE (mills/kWh) @ 85% CF	58.9
TPC/TOC	1,647/2,024

Figure 1. Process Flow Diagram  
Supercritical Pulverized Coal Unit

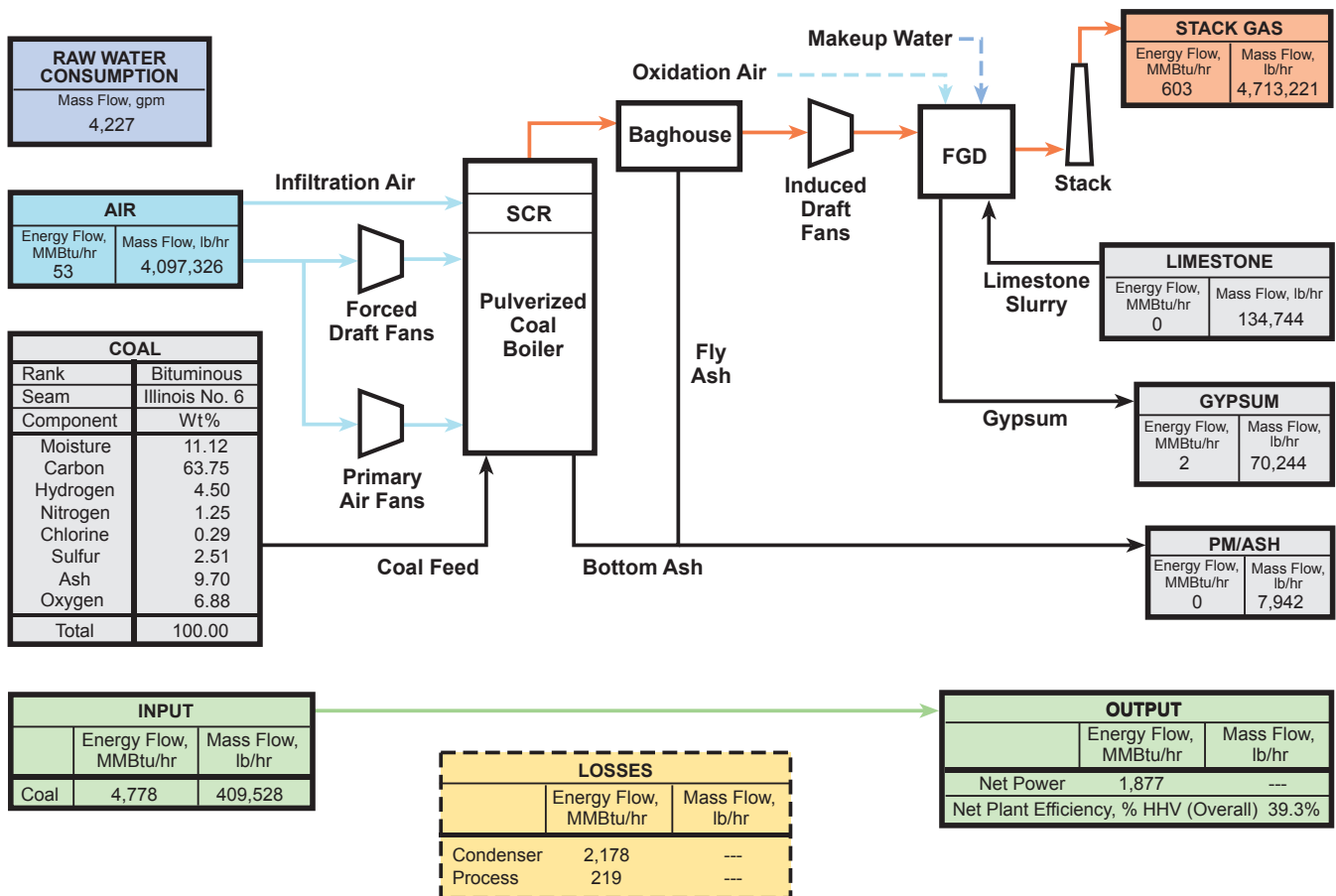

Note: Diagram is provided for general reference of major flows only. For complete flow information, please refer to the final report.

## Technical Description

The analysis for the supercritical PC plant is based on a commercially available supercritical dry-bottom, wall-fired boiler equipped with low-nitrogen oxides burners (LNB) with over-fire air (OFA) and selective catalytic reduction (SCR). The unit is a balanced-draft, natural-circulation design equipped with a superheater, reheater, economizer, and air preheater. Hot flue gas exiting the boiler is treated by an SCR unit for nitrogen oxides (NO<sub>x</sub>) removal, a baghouse for particulate matter (PM) removal, and a wet limestone forced oxidation scrubber for sulfur dioxide (SO<sub>2</sub>) control and co-removal of mercury (Hg). This plant utilizes a conventional steam turbine for power generation. The Rankine cycle is based on a single reheat system with steam conditions of 24.1 MPa/ 593°C/593°C (3,500 psig/1,100°F/1,100°F).

Achieving a nominal 550 MWe net output with this plant configuration results in a thermal input requirement of 1,400 MWt. This thermal input is achieved by burning coal at a rate of 409,528 lb/hr, which yields a net plant heat rate of 8,687 Btu/kWh (net plant efficiency of 39.3 percent). The gross power output of 580 MWe is produced from the steam turbine generator. With an auxiliary power requirement of 30.4 MWe, the net plant output is 550 MWe.

## Environmental Performance

This study assumes the use of BACT to meet the emission requirements of the 2006 New Source Performance Standards.

The supercritical PC plant has an emission control strategy consisting of LNBs with OFA and SCR for NO<sub>x</sub> control, a pulse jet fabric filter for PM control, and a wet-limestone, forced-oxidation scrubber for SO<sub>2</sub> control. After NO<sub>x</sub> emissions are initially controlled through the use of LNBs and OFA, an SCR unit is used to further reduce the NO<sub>x</sub> concentration by 86 percent. Particulate emissions are controlled using a pulse jet fabric filter, which operates at an efficiency of 99.8 percent. The wet-limestone, forced-oxidation scrubber for SO<sub>2</sub> control achieves 98 percent removal efficiency. The byproduct, calcium sulfate, is dewatered and stored onsite. The wallboard-grade material can potentially be marketed and sold but, since it is highly dependent on local market conditions, no byproduct credit is taken. The combination of SCR, a fabric filter, and wet scrubber also provides co-benefit Hg capture at an assumed 90 percent of the inlet value.

A summary of the resulting air emissions is presented in Table 2.

**Table 2. Air Emissions Summary at 85% Capacity Factor**

Pollutant	PC Supercritical Without CCS
<b>CO<sub>2</sub></b>	
• million tonnes/year	3,284
• lb/MWh <sub>net</sub>	1,768
<b>SO<sub>2</sub></b>	
• tonne/year	1,385
• lb/MMBtu	0.086
<b>NO<sub>x</sub></b>	
• tonne/year	1,130
• lb/MMBtu	0.070
<b>PM (filterable)</b>	
• tonne/year	210
• lb/MMBtu	0.013
<b>Hg</b>	
• tonne/year	0.018
• lb/TBtu	1.143

## Cost Estimation

Estimates of capital and operations costs were developed for each plant based on adjusted vendor-furnished and actual cost data from recent design/build projects. These costs were used to calculate a first year cost-of-electricity (COE) based on the power plant costs and assumed financing structure. Financial assumptions and a cost summary are shown in Table 3.



Project contingencies were added to each case to cover project uncertainty and the cost of any additional equipment that could result from detailed design. The project contingencies represent costs that are expected to occur. Project contingency was 8.7 percent for the supercritical PC case Total Plant Cost (TPC). No process contingency is included in this case because all elements of the technology are commercially proven.

This study assumes that each new plant would be dispatched any time it is available and would be capable of generating maximum capacity when online. Therefore, CF is assumed to equal availability and is 85 percent for PC cases.

The 550 MWe supercritical PC plant is projected to have a Total Overnight Cost (TOC) of \$2,024/kWe, resulting in a COE of 58.9 mills/kWh.

**Table 3. Major Financial Assumptions and Resulting Cost Summary<sup>1</sup>**

<b>Major Assumptions</b>			
Case:	<b>1x550 MWe net Supercritical PC</b>		
Plant Size:	550.0 (MWe, net)	Heat Rate:	8,687 (Btu/kWh)
Primary/Secondary Fuel (type):	Illinois No. 6 Coal	Fuel Cost:	1.64 (\$/MMBtu)
Capital Expenditure Period:	5 (years)	Plant Life:	30 (years)
Cost Basis Year:	2007 (June)	Plant in Service:	2012 (June)
Capacity Factor:	85 (%)	Capital Charge Factor:	11.6 (%)
<b>Resulting Capital Investment (2007 dollars)</b>			<b>Mills/kWh</b>
Total Overnight Cost <sup>2</sup>			31.7
<b>Resulting Operating Costs (2007 dollars)<sup>3</sup></b>			<b>Mills/kWh</b>
Fixed Operating Cost			8.0
Variable Operating Cost			5.0
<b>Resulting Fuel Cost (2007 dollars) at \$1.80 / MMBtu</b>			<b>Mills/kWh</b>
			14.2
<b>Total Busbar Cost of Power (2007 dollars)</b>			<b>Mills/kWh</b>
			58.9

<sup>1</sup>Costs shown can vary -15%/+30%.

<sup>2</sup>Total overnight cost includes all equipment (complete with initial chemical and catalyst loadings), materials, labor (direct and indirect), engineering and construction management, and contingencies (process and project), and owner's cost.

<sup>3</sup>No credit taken for by-product sales.

**Contacts**

**James Black**

General Engineer  
National Energy Technology Laboratory  
626 Cochrans Mill Road  
P.O. Box 10940  
Pittsburgh, PA 15236  
412-386-5458  
james.black@netl.doe.gov

**Larry Rath**

Director of Performance Division  
National Energy Technology Laboratory  
626 Cochrans Mill Road  
P.O. Box 10940  
Pittsburgh, PA 15236  
412-386-6871  
larry.rath@netl.doe.gov

References

Cost and Performance Baseline for Fossil Energy Plants, Vol. 1. (2010, November). Pittsburgh, PA. DOE/NETL-2010/1397.  
CoalFleet User Design Basis Specification for Coal-Based Integrated Gasification Combined Cycle (IGCC) Power Plants, (2009). EPRI, Palo Alto, CA. 1017501.

# Supercritical Pulverized Coal Plant With Carbon Capture and Sequestration

## Plant Overview

This analysis is based on a 550 MWe (net power output) supercritical bituminous pulverized coal (PC) plant located at a greenfield site in the midwestern United States. This plant captures carbon dioxide (CO<sub>2</sub>) to be sequestered and is designed to meet Best Available Control Technology (BACT) emission limits. The plant is a single-train design. The combination process, heat, and mass balance diagram for the supercritical PC plant with carbon capture and sequestration (CCS) is shown in Figure 1. The primary fuel is an Illinois No. 6 bituminous coal with a higher heating value (HHV) of 11,666 Btu/lb. The capacity factor (CF) for the plant is 85 percent without sparing of major train components. A summary of plant performance data for the supercritical PC plant with CCS is presented in Table 1.

Table 1. Plant Performance Summary

Plant Type	PC Supercritical
Carbon capture	Yes
Net power output (kWe)	549,970
Net plant efficiency (%)	28.4
Primary fuel (type)	Illinois No. 6 coal
COE (mills/kWh) @ 85% CF	106.5
Total plant cost (\$ x 1,000)	2,913/3,570
Cost of CO <sub>2</sub> avoided <sup>1</sup> (\$/tonne)	69/69
Analogous/Supercritical PC Ref.	

<sup>1</sup>The avoided costs for each capture case are calculated using the analogous non-capture plant as the reference and again with SC PC without CO<sub>2</sub> capture as the reference.

Figure 1. Process Flow Diagram  
Supercritical Pulverized Coal Unit With CCS

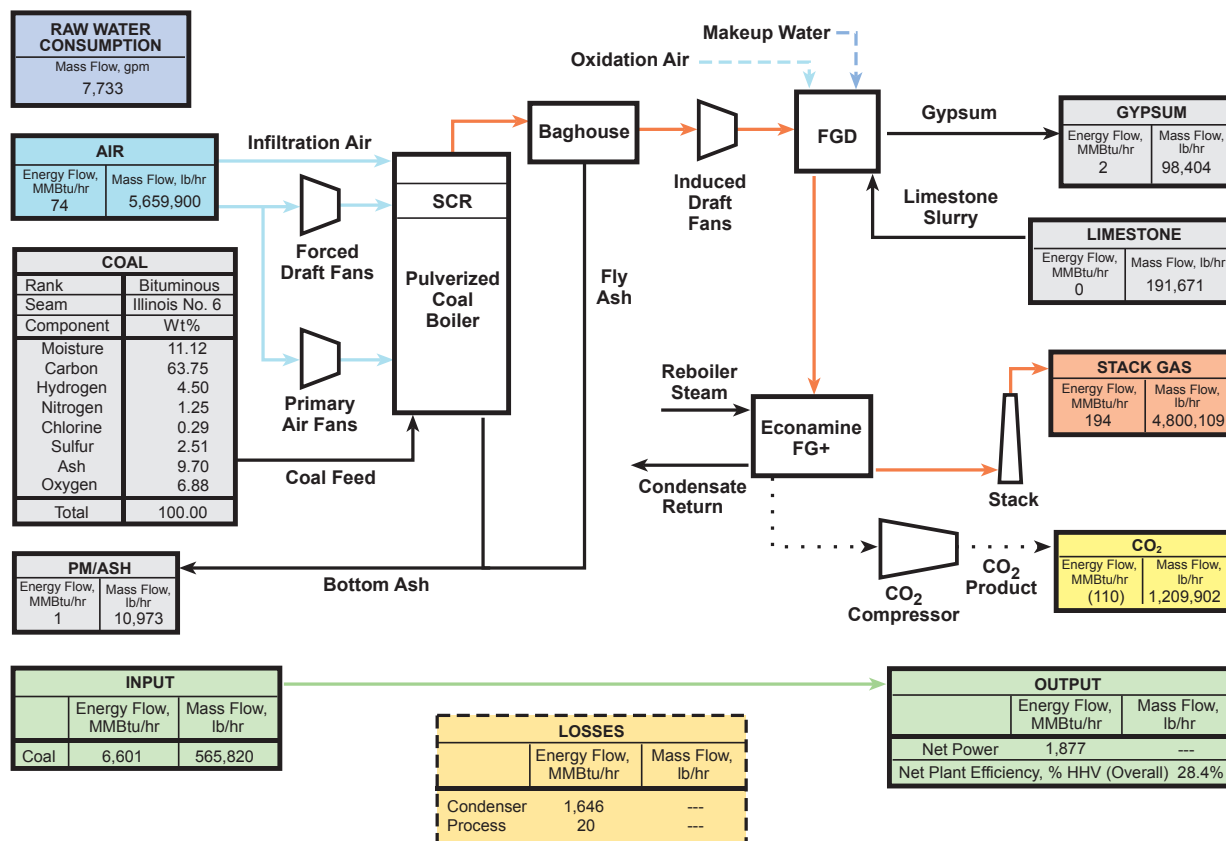

Note: Diagram is provided for general reference of major flows only. For complete flow information, please refer to the final report.

## Technical Description

The analysis for the supercritical PC plant with CCS is based on a commercially available supercritical dry-bottom, wall-fired boiler equipped with low-nitrogen oxides (NO<sub>x</sub>) burners (LNB), over-fire air (OFA), and selective catalytic reduction (SCR). The unit is a balanced-draft, natural-circulation design equipped with a superheater, reheater, economizer, and air preheater. Hot flue gas (FG) exiting the boiler is treated by an SCR unit for NO<sub>x</sub> removal, a baghouse for particulate matter (PM) removal, and a wet-limestone, forced-oxidation scrubber for sulfur dioxide (SO<sub>2</sub>) control and co-removal of mercury (Hg). This plant utilizes a conventional steam turbine for power generation. The single reheat system uses a Rankine cycle with steam conditions of 24.1 MPa/593°C/593°C (3,500 psig/1,100°F/1,100°F).

This supercritical PC plant with CCS is equipped with the Fluor Econamine FG Plus™ technology for carbon capture. Flue gas exiting the scrubber system is directed to the Econamine FG Plus™ process, where CO<sub>2</sub> is absorbed in a monethanolamine-based solvent. A booster blower is required to overcome the process pressure drop. Carbon dioxide recovered in the Econamine FG Plus™ process is dried, compressed, and delivered to the plant fence line at 15.3 MPa (2,215 psia) for subsequent pipeline transport and sequestration. The compressed CO<sub>2</sub> is transported via pipeline to a geologic sequestration field for injection into a saline aquifer, which is located within 50 miles of the plant.

Achieving a nominal 550 MWe net output with this plant configuration, results in a thermal input requirement of 1,935 MWt. This thermal input is achieved by burning coal at a rate of 565,820 lb/hr, which yields a net plant heat rate of 12,002 Btu/kWh (net plant efficiency of 28.4 percent). The gross power output produced from the steam turbine generator is 663 MWe. With an auxiliary power requirement of 113 MWe, the net plant output is 550 MWe. The Econamine FG Plus™ process imposes a significant auxiliary power load on the system, which requires this case to have a higher gross output, as compared to the supercritical case without CCS, to maintain approximately the same net output.

## Environmental Performance

This study assumes the use of BACT to meet the emission requirements of the 2006 New Source Performance Standard for criteria pollutants.

The supercritical PC plant with CCS has an emission control strategy consisting of LNBS with OFA and SCR for NO<sub>x</sub> control, a pulse jet fabric filter for PM control, and a wet-limestone, forced-oxidation scrubber for SO<sub>2</sub> control. After NO<sub>x</sub> emissions are initially controlled through the use of LNBS and OFA, an SCR unit is used to further reduce the NO<sub>x</sub> concentration by 86 percent. Particulate emissions are controlled using a pulse jet fabric filter, which operates at an efficiency of 99.8 percent. The wet-limestone, forced-oxidation scrubber achieves a 98 percent removal of SO<sub>2</sub>. A polishing scrubber included as part of the Econamine FG Plus™ process further reduces the SO<sub>2</sub> concentration to less than 10 ppmv. The balance of the SO<sub>2</sub> is removed in the Econamine absorber resulting in negligible SO<sub>2</sub> emissions. The byproduct from the wet-limestone scrubber calcium sulfate, is dewatered and stored onsite. The wallboard-grade material potentially can be marketed and sold, but since it is highly dependent on local market conditions, no byproduct credit is taken. The combination of SCR,

**Table 2. Air Emissions Summary at 85% Capacity Factor**

Pollutant	PC Supercritical With CCS (90%)
<b>CO<sub>2</sub></b>	
• million tonnes/year	0.454
• lb/MWh <sub>net</sub>	244
<b>SO<sub>2</sub></b>	
• tonne/year	36
• lb/MMBtu	0.002
<b>NO<sub>x</sub></b>	
• tonne/year	1,561
• lb/MMBtu	0.070
<b>PM</b>	
• tonne/year	290
• lb/MMBtu	0.013
<b>Hg</b>	
• tonne/year	0.025
• lb/TBtu	1.143

a fabric filter, and wet scrubber also provides co-benefit Hg capture at an assumed 90 percent of the inlet value. The saturated FG exiting the scrubber is directed to the Econamine FG Plus™ process for CO<sub>2</sub> recovery. A booster blower is required to overcome the process pressure drop. After leaving the Econamine FG Plus™ process, the flue gas is vented through the plant stack.

A summary of the resulting air emissions is presented in Table 2.

## Cost Estimation

Estimates of capital and operations costs were developed for each plant based on adjusted vendor-furnished and actual cost data from recent design/build projects. These costs were used to calculate a first year cost-of-electricity (COE) based on the power plant costs and assumed financing structure. Financial assumptions and a cost summary are shown in Table 3.

Project contingencies were added to each case to cover project uncertainty and the cost of any additional equipment that could result from detailed design. The project contingencies represent costs that are expected to occur. Project contingency was 10.2 percent for the supercritical PC CCS case Total Plant Cost (TPC).

Process contingency is intended to compensate for uncertainties arising as a result of the state of technology development. Process contingencies represent 2.8 percent of the supercritical PC CCS case TPC and have been applied to the estimates as follows:

- CO<sub>2</sub> Removal System – 20 percent on all PC CCS cases
- Instrumentation and Controls – 5 percent on the PC CCS cases

This study assumes that each new plant would be dispatched any time it is available and would be capable of generating maximum capacity when online. Therefore, CF is assumed to equal availability and is 85 percent for PC cases.

For the PC cases that feature CCS, capital and operating costs were estimated for transporting CO<sub>2</sub> to an underground storage area, associated storage maintenance, and for monitoring beyond the expected life of the plant.

The 550 (net) MWe supercritical PC plant with CCS was projected to have Total Overnight Cost (TOC) of \$3,570/kWe, resulting in a COE of 106.5 mills/kWh.

Table 3. Major Financial Assumptions and Resulting Cost Summary<sup>1</sup>

<b>Major Assumptions</b>			
Case:	<b>1x550 MWe net Supercritical PC with CCS</b>		
Plant Size:	550.0 (MWe, net)	Heat Rate:	12,002 (Btu/kWh)
Primary/Secondary Fuel (type):	Illinois No. 6 Coal	Fuel Cost:	1.64 (\$/MMBtu)
Capital Expenditure Period:	5 (years)	Plant Life:	30 (years)
Cost Basis Year:	2007 (June)	Plant in Service:	2012 (June)
Capacity Factor:	85 (%)	Capital Charge Factor:	12.4 (%)
<b>Resulting Capital Investment (2007 dollars)</b>			<b>Mills/kWh</b>
Total Overnight Cost <sup>2</sup>			59.6
<b>Resulting Operating Costs (2007 dollars)<sup>3</sup></b>			<b>Mills/kWh</b>
Fixed Operating Cost			13.0
Variable Operating Cost			8.7
<b>Resulting Fuel Cost (2007 dollars) at \$1.80 / MMBtu</b>			<b>Mills/kWh</b>
			19.6
<b>Resulting CO<sub>2</sub> Cost (2007 dollars)</b>			<b>Mills/kWh</b>
			5.6
<b>Total Busbar Cost of Power (2007 dollars)</b>			<b>Mills/kWh</b>
			106.5

<sup>1</sup>Costs shown can vary -15%/+30%.

<sup>2</sup>Total overnight cost includes all equipment (complete with initial chemical and catalyst loadings), materials, labor (direct and indirect), engineering and construction management, and contingencies (process and project), and owner’s cost.

<sup>3</sup>No credit taken for by-product sales.

### Contacts

**James Black**  
 General Engineer  
 National Energy Technology Laboratory  
 626 Cochrans Mill Road  
 P.O. Box 10940  
 Pittsburgh, PA 15236  
 412-386-5458  
 james.black@netl.doe.gov

**Larry Rath**  
 Director of Performance Division  
 National Energy Technology Laboratory  
 626 Cochrans Mill Road  
 P.O. Box 10940  
 Pittsburgh, PA 15236  
 412-386-6871  
 larry.rath@netl.doe.gov

### References

Cost and Performance Baseline for Fossil Energy Plants, Vol. 1. (2010, November). Pittsburgh, PA. DOE/NETL-2010/1397.

CoalFleet User Design Basis Specification for Coal-Based Integrated Gasification Combined Cycle (IGCC) Power Plants, (2009). EPRI, Palo Alto, CA. 1017501.

# Natural Gas Combined-Cycle Plants With and Without Carbon Capture and Sequestration

## Technology Overview

Two Natural Gas Combined-Cycle (NGCC) power plant configurations were evaluated, and the results are presented in this summary sheet. Both cases were analyzed using a consistent set of assumptions and analytical tools. The two configurations evaluated are based on an NGCC plant with and without carbon capture and sequestration (CCS).

- NGCC plant utilizing Advanced F-Class combustion turbine generators (CTG).
- NGCC plant utilizing Advanced F-Class CTGs with CCS.

Each NGCC plant design is based on a market-ready technology that is assumed to be commercially available in time to support a 2010 startup date. The NGCC plants are built at a greenfield site in the midwestern United States and are assumed to operate in baseload mode at 85 percent capacity factor (CF) without sparing of major train components. Nominal plant size (gross rating) is 570 MWe without CCS and 520 MWe with CCS. All designs consist of two advanced F-Class CTGs, two heat recovery steam generators (HRSG), and one steam turbine generator in a multi-shaft 2x2x1 configuration.

The NGCC cases were evaluated with and without CCS on a common thermal input basis. The case that includes CCS is equipped with the Fluor Econamine (FG) Plus™ process. The NGCC with CCS case also has a smaller plant net output resulting from the additional CCS facility auxiliary loads and steam consumption. After compression to pipeline specification pressure, the carbon dioxide (CO<sub>2</sub>) is assumed to be transported to a nearby underground storage facility for sequestration.

The size of the NGCC designs was determined by the output of the commercially available combustion turbine. Therefore, evaluation of the NGCC designs on a common net output basis was not possible. For the cases with and without CCS, respective gross output was 511 and 565 MWe, and respective net output was 474 and 555 MWe. The natural gas (NG) flowrate was 167,333 lb/hr in both cases. See Figure 1 for a generic block flow diagram of an NGCC plant. The orange blocks in the figure represent the unit operations added to the configuration for CCS cases.

Figure 1. NGCC Plant

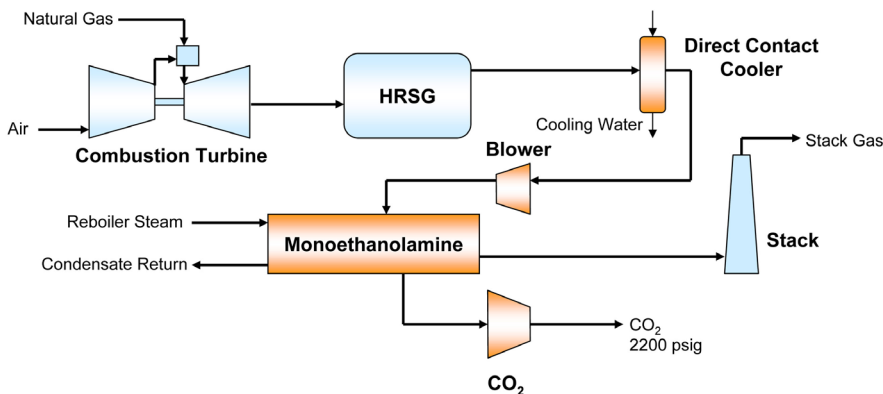

**Nitrogen oxides control:**  
dry low-NO<sub>x</sub> burner + selective catalytic reduction to maintain 2.5 ppmvd @ 15% oxygen

**Carbon dioxide control:**  
Monoethanolamine system for 90% removal

**Steam conditions:**  
2,400 psig/1,050°F/950°F

Orange blocks indicate unit operations added for CCS case.

Note: Diagram is provided for general reference of major flows only. For complete flow information, please refer to the final report.

## Technical Description

The combined-cycle plant was based on two CTGs. The CTG is representative of the advanced F-Class CTGs with an International Standards Organization base rating of 184,400 kWe (when firing NG). This machine is an axial flow, single-shaft, constant-speed unit, with variable inlet guide vanes and Multi-Nozzle Quiet Combustor dry low-NOx (DLN) burner combustion system. Additionally, a selective catalytic reduction (SCR) system further reduces the nitrogen oxides (NOx) emissions. The Rankine cycle portion of both designs uses a single-reheat 16.5 MPa/566°C/566°C (2,400 psig/1,050°F/1,050°F) cycle. Recirculating evaporative cooling systems are used for cycle heat rejection. The efficiency of the case without CCS is almost 51 percent, with a gross rating of 570 MWe.

The CCS case requires a significant amount of auxiliary power and extraction steam for the process, which reduces the output of the steam turbine. This results in a lower net plant output for the CCS cases of about 474 MWe for an average net plant efficiency of almost 43 percent on a higher heating value (HHV basis).

The CCS case is equipped with the Fluor Econamine Flue Gas (FG) Plus™ technology, which removes 90 percent of the CO<sub>2</sub> in the FG exiting the HRSG unit. Once captured, the CO<sub>2</sub> is dried and compressed to 15.3 MPa (2,215 psia). The compressed CO<sub>2</sub> is transported via pipeline to a geologic sequestration field for injection into a saline formation, which is located within 50 miles of the plant. Therefore, CO<sub>2</sub> transport, storage, and monitoring costs (TS&M) are included in the analyses.

### Fuel Analysis and Costs

The design NG characteristics are presented in Table 1. Both NGCC cases were modeled with the design NG.

A NG cost of \$6.21/MMkJ (\$6.55/MMBtu) (June 2007 dollars) was determined using data from the Energy Information Administration AEO2008.

### Environmental Design Basis

The environmental design for this study was based on evaluating both of the NGCC cases using the same regulatory design basis. The environmental specifications for a greenfield NGCC plant are based on the pipeline-quality NG specification in Table 1 and EPA 40 CFR Part 60, Subpart KKKK. Table 2 provides details of the environmental design basis for NGCC plants built at a midwestern U.S. location. The emissions controls assumed for each of the two NGCC cases are as follows:

- Dry low-NOx burners in conjunction with SCR for NOx control in both cases
- Econamine process for CO<sub>2</sub> capture in the CCS case

NGCC plants produce negligible amounts of SO<sub>2</sub>, particulate matter (PM), and mercury (Hg); therefore, no emissions controls equipment or features are required for these pollutants.

Table 1. Fuel Analysis

Natural Gas		
Component		Volume Percentage
Methane	CH <sub>4</sub>	93.1
Ethane	C <sub>2</sub> H <sub>6</sub>	3.2
Propane	C <sub>3</sub> H <sub>8</sub>	0.7
n-Butane	C <sub>4</sub> H <sub>10</sub>	0.4
Carbon dioxide	CO <sub>2</sub>	1.0
Nitrogen	N <sub>2</sub>	1.6
<b>Total</b>		<b>100.0</b>
	<b>LHV</b>	<b>HHV</b>
	kJ/kg	47,764
	kJ/scm	34.71
	Btu/lb	20,410
	Btu/scf	932

Table 2. Environmental Targets

Pollutant	NGCC
SO <sub>2</sub>	Negligible
NOx	2.5 ppmvd @ 15% Oxygen
PM (filterable)	Negligible
Hg	N/A



## Major Economic and Financial Assumptions

For the NGCC cases, estimates of capital and operations costs were developed for each plant based on adjusted vendor-furnished and actual cost data from recent design/build projects. These costs were used to calculate a first year cost-of-electricity (COE) based on the power plant costs and assumed financing structure. Listed in Table 3 are the major economic and financial assumptions for the two NGCC cases.

Project contingencies were added to each of the cases to cover project uncertainty and the cost of any additional equipment that could result from detailed design. The project contingencies represent costs that are expected to occur. Project contingency was 10.6 percent for the NGCC case without CCS Total Plant Cost (TPC) and roughly 13.3 percent for the NGCC case with CCS.

Process contingency is intended to compensate for uncertainties arising as a result of the state of technology development. Process contingencies have been applied to the estimates as follows:

- CO<sub>2</sub> Removal System – 20 percent on all NGCC CCS cases
- Instrumentation and Controls – 5 percent on the NGCC CCS cases

This study assumes that each new plant would be dispatched any time it is available and would be capable of generating maximum capacity when online. Therefore, CF is assumed to equal availability and is 85 percent for NGCC cases.

For the NGCC case that features CCS, capital and operating costs were estimated for transporting CO<sub>2</sub> to an underground storage field, associated storage in a saline aquifer, and for monitoring beyond the expected life of the plant.

## Results

The results of the analysis of the two NGCC cases are presented in the following sections.

### Capital Cost

Total Overnight Cost (TOC) for each of the two NGCC cases is compared in Figure 2. The TOC includes all equipment (complete with initial chemical and catalyst loadings), materials, labor (direct and indirect), engineering and construction management, and contingencies (process and project), and owner's cost. Interest during construction and escalation during construction are not included as owner's costs but are factored into the COE and are included in Total As-spent Cost (TASC).

The results of the analysis indicate that an NGCC costs \$718/kWe, and that an additional \$779/kWe is needed for the NGCC plant with CCS.

**Table 3. Major Economic and Financial Assumptions for NGCC Cases**

Major Economic Assumptions	
Capacity factor	85%
Costs year in constant U.S. dollars	2007 (June)
Natural gas delivered cost	\$6.55/MMBtu
Construction duration	3 Years
Plant startup date	2010 (June)
Major Financial Assumptions	
Depreciation	20 years
Federal income tax	34%
State income tax	6%
Low risk cases	
After-tax weighted cost of capital	7.39%
Capital structure:	
Common equity	50% (Cost = 12%)
Debt	50% (Cost = 9%)
Capital charge factor	10.5%
High risk cases	
After-tax weighted cost of capital	8.13%
Capital structure:	
Common equity	55% (Cost = 12%)
Debt	45% (Cost = 11%)
Capital charge factor	11.1%

**Figure 2. Comparison of TOC for the Two NGCC Cases**

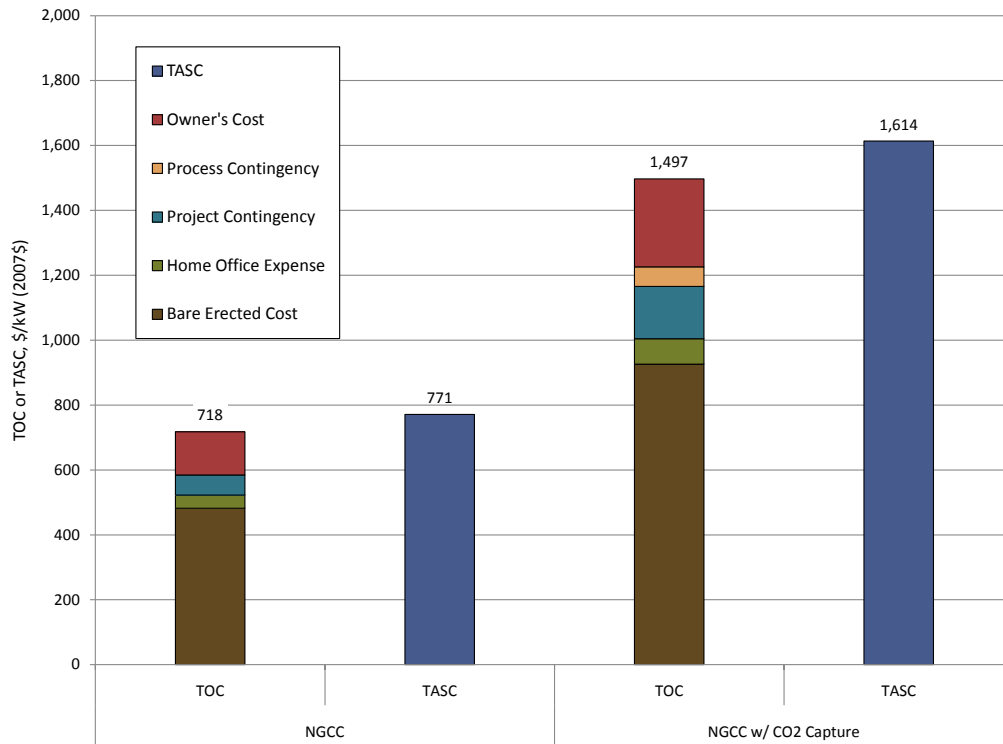

## Efficiency

The net plant efficiencies for the two NGCC cases are compared in Figure 3. This analysis indicates that adding CCS to the NGCC reduces plant efficiency by more than 7 percentage points, from 50.2 percent to 42.8 percent.

**Figure 3. Comparison of Net Plant Efficiency for the Two NGCC Cases**

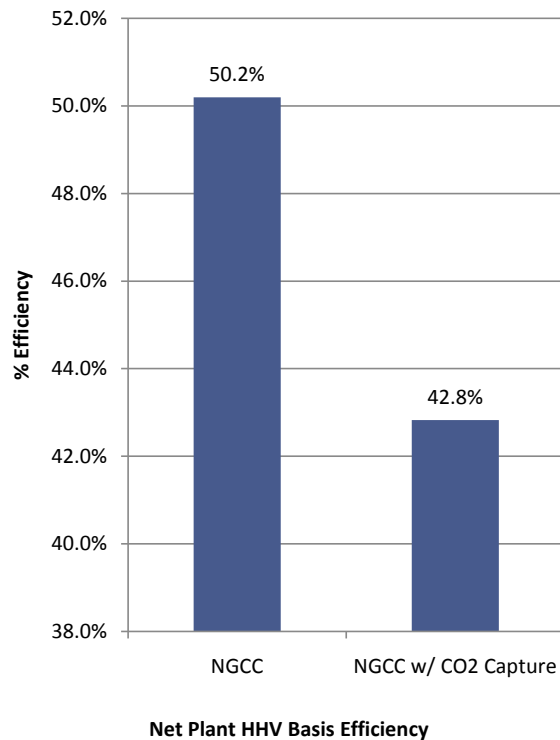

## Cost-of-Electricity

The COE is a measurement of the coal-to-busbar cost of power, and includes the TOC, fixed and variable operating costs, and fuel costs. The calculated cost of TS&M for CO<sub>2</sub> adds roughly 3 mills/kWh to the COE.

The NGCC without CCS plant generates power at an COE of 58.9 mills/kWh at a CF of 85.9 percent. When CCS is included, the increased TOC and reduced efficiency result in a higher COE of 86 mills/kWh.

Figure 4. Comparison of Cost-of-Electricity for the Two NGCC Cases

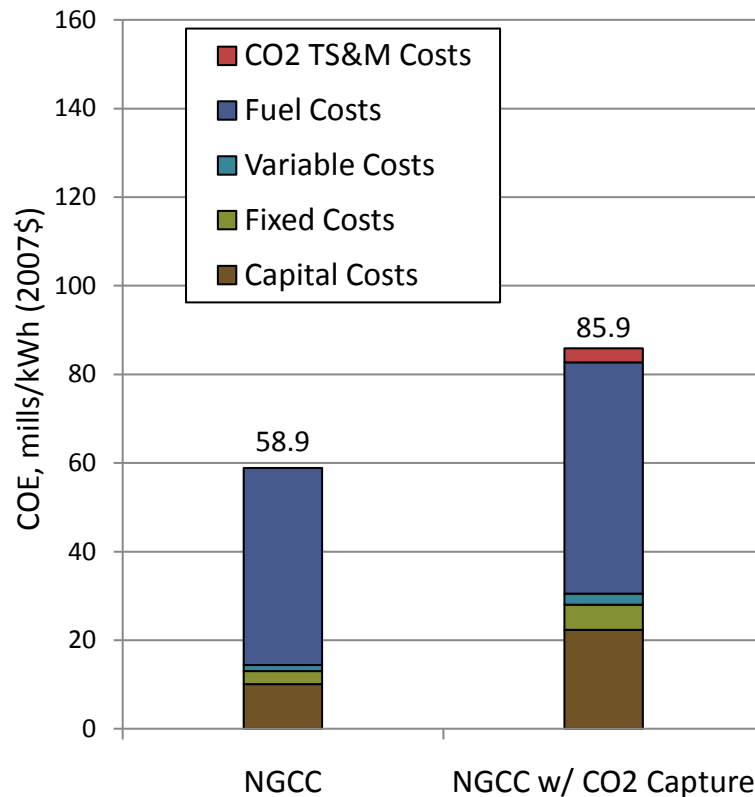

## Environmental Impacts

Listed in Table 4 is a comparative summary of emissions from the two NGCC cases. Mass emission rates and cumulative annual totals are given for sulfur dioxide (SO<sub>2</sub>), NO<sub>x</sub>, PM, Hg, and CO<sub>2</sub>.

The emissions from both NGCC plants evaluated meet or exceed Best Available Control Technologies requirements for the design NG specification and EPA 40 CFR Part 60, Subpart KKKK. The CO<sub>2</sub> is reduced by 90 percent in the capture case, resulting in less than 0.151 million tonnes/year of CO<sub>2</sub> emissions. The cost of CO<sub>2</sub> avoided is defined as the difference in the COE between controlled and uncontrolled like cases, divided by the difference in CO<sub>2</sub> emissions in kg/MWh. In this analysis, the cost of CO<sub>2</sub> avoided is about \$91.5/tonne. Sulfur dioxide, Hg, and PM emissions are negligible. Raw water usage in the CCS case is over 85 percent greater than for the case without CCS primarily because of the large Econamine process cooling water demand.

**Table 4. Comparative Emissions for the Two NGCC Cases at 85% Capacity Factor**

Plant Type	NGCC	
	Without CCS	With CCS (90%)
<b>CO<sub>2</sub></b>		
• million tonnes/year	1.507	0.151
• lb/MWh <sub>net</sub>	804	94
• Cost of CO <sub>2</sub> avoided <sup>1</sup> (\$/tonne) Analogous/Supercritical PC Ref.	N/A	84/36
<b>SO<sub>2</sub></b>		
• tonne/year	N/A	N/A
• lb/10 <sup>6</sup> Btu	N/A	N/A
<b>NO<sub>x</sub></b>		
• tonne/year	115	127
• lb/MMBtu	0.060	0.008
<b>PM (filterable)</b>		
• tonne/year	N/A	N/A
• lb/MMBtu	N/A	N/A
<b>Hg</b>		
• tonne/year	N/A	N/A
• lb/TBtu	N/A	N/A
<b>Raw water consumption, gpm</b>	1,831	2,985

## Contacts

### James Black

General Engineer  
National Energy Technology Laboratory  
626 Cochran's Mill Road  
P.O. Box 10940  
Pittsburgh, PA 15236  
412-386-5458  
james.black@netl.doe.gov

### Larry Rath

Director of Performance Division  
National Energy Technology Laboratory  
626 Cochran's Mill Road  
P.O. Box 10940  
Pittsburgh, PA 15236  
412-386-6871  
larry.rath@netl.doe.gov

## References

- Cost and Performance Baseline for Fossil Energy Plants, Vol. 1. (2010, November). Pittsburgh, PA. DOE/NETL-2010/1397.
- CoalFleet User Design Basis Specification for Coal-Based Integrated Gasification Combined Cycle (IGCC) Power Plants, (2009). EPRI, Palo Alto, CA. 1017501.

# Natural Gas Combined-Cycle Plant

## Plant Overview

This analysis is based on a 555 MWe (net power output) natural gas combined-cycle (NGCC) plant located at a greenfield site in the midwestern United States. This plant is designed to meet Best Available Control Technology (BACT) emission limits. The combination process, heat, and mass balance diagram for the NGCC plant is shown in Figure 1. The primary fuel is natural gas (NG) with a higher heating value (HHV) of 22,600 Btu/lb. The plant is assumed to operate in baseload mode at a capacity factor (CF) of 85 percent without sparing of major train components. A summary of plant performance data for the NGCC plant is presented in Table 1.

Table 1. Plant Performance Summary

Plant Type	NGCC
Carbon capture	No
Net power output (kWe)	555,080
Net plant efficiency (%)	50.2
Primary fuel (type)	Natural Gas
COE (mills/kWh) @ 85% CF	58.9
TPC/TOC (\$/kW)	584/718

Figure 1. Process Flow Diagram NGCC

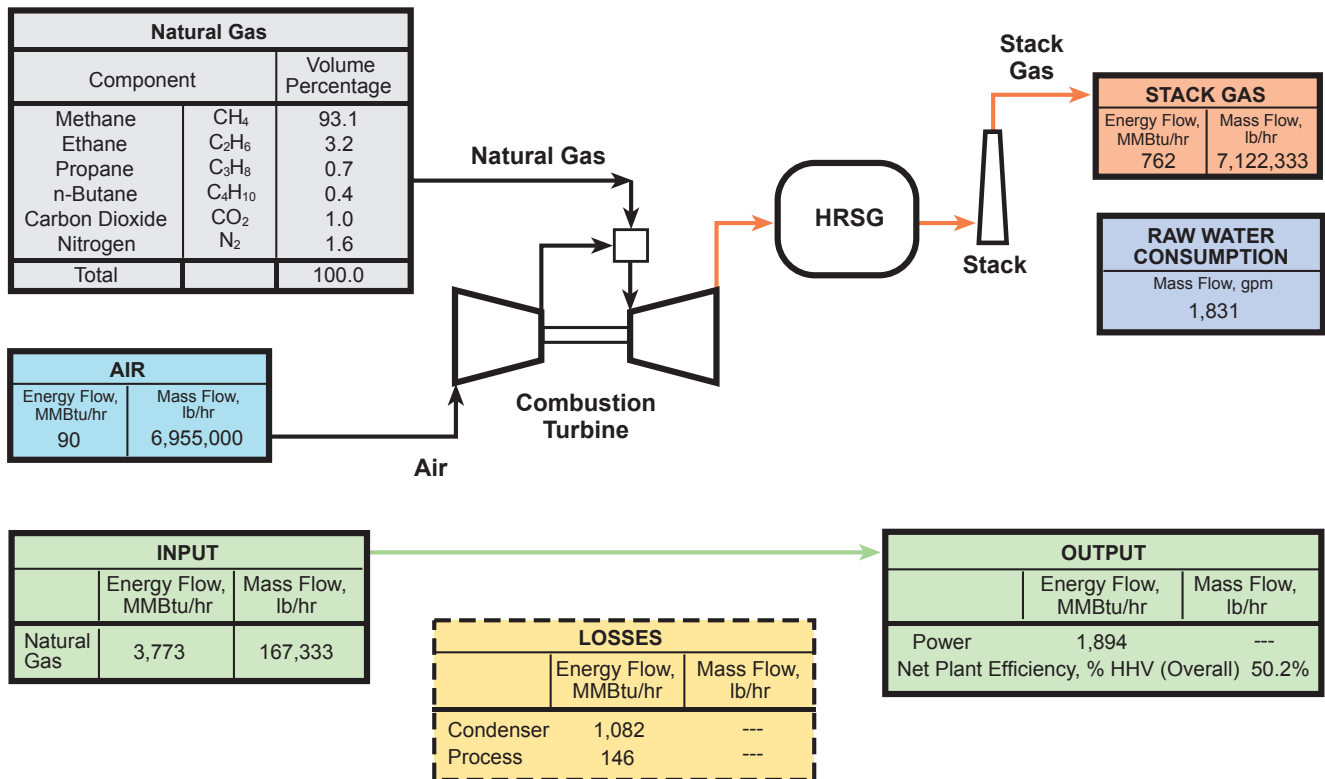

Note: Diagram is provided for general reference of major flows only. For complete flow information, please refer to the final report.

## Technical Description

The analysis for the NGCC plant is based on two advanced F-Class combustion turbine generators (CTG) that are assumed to be commercially available to support startup in 2010, two heat recovery steam generators (HRSG), and one steam turbine generator (STG) in a multi-shaft 2x2x1 configuration with a recirculating wet cooling tower for cycle heat rejection.

The unit consists of an NG system that feeds NG at the required pressure and temperature to the two axial flow, constant-speed CTGs with variable inlet guide vanes, and a dry low-NOx (DLN) burner combustion system. Each CTG exhausts to an HRSG configured with high-, intermediate-, and low-pressure steam systems including drum, superheater, reheater, and economizer sections. Steam from both HRSGs flows to a conventional steam turbine for power generation. The Rankine cycle consists of a single reheat system with steam conditions of 16.5 MPa/566°C/566°C (2,400 psig/1,050°F/1,050°F). Nitrogen oxide (NOx) emissions are controlled to 25 ppmvd (referenced to 15 percent oxygen (O<sub>2</sub>)) by the DLN combustion system and then further reduced by a selective catalytic reduction (SCR) system. The SCR system was designed for 90 percent reduction of NOx. These together achieve the emission limit of 2.5 ppmvd NOx (referenced to 15 percent O<sub>2</sub>). All other support systems and equipment are typical for a conventional NGCC plant. Plant performance is based on the properties of pipeline-quality NG.

Achieving a nominal 555 MWe net output with such a plant configuration results in a thermal input requirement of 1,106 MWt. This thermal input is achieved by burning NG at a rate of 167,333 lb/hr, which yields a net plant heat rate of 6,798 Btu/kWh (HHV-basis efficiency of 50.2 percent). The gross power output of 565 MWe is produced from the advanced CTGs and the STG. With an auxiliary power requirement of 10 MWe, the net plant output is 555 MWe. The summary of plant electrical generation performance is presented in Table 2.

**Table 2. Plant Electrical Generation**

	Electrical Summary
Advanced gas turbine x 2, MWe	362.2
Steam turbine, MWe	202.5
Gross power output, MWe	564.7
Auxiliary power requirement, MWe	(9.6)
Net power output, MWe	555.1

## Environmental Performance

This study assumes the use of BACT to meet the emission requirements of the 2006 New Source Performance Standards.

NGCC plants use NG as their fuel, which creates negligible emissions of sulfur dioxide (SO<sub>2</sub>), particulate matter (PM), and mercury (Hg); therefore, NGCC plants require no emissions controls equipment or features to reduce these emissions. NOx emissions are controlled to 25 ppmvd (referenced to 15 percent O<sub>2</sub>) by the DLN combustion system and then further reduced by an SCR system. The SCR system was designed for 90 percent reduction while firing NG. The DLN burner, together with the SCR, achieves the emission limit of 2.5 ppmvd (referenced to 15 percent O<sub>2</sub>).

A summary of the resulting air emissions is presented in Table 3.

## Cost Estimation

Estimates of capital and operations costs were developed for each plant based on adjusted vendor-furnished and actual cost data from recent design/build projects. These costs were used to calculate a first year cost-of-electricity (COE) based on the power plant costs and assumed financing structure. Financial assumptions and a cost summary are shown in Table 4.

Project contingencies were added to each case to cover project uncertainty and the cost of any additional equipment that could result from detailed design. The project contingencies represent costs that are expected to occur. Project contingency was 8.6 percent of the Total Plant Cost (TPC).

No process contingency is included in this case because all elements of the technology are commercially proven.

This study assumes that each new plant would be dispatched any time it is available and would be capable of generating maximum capacity when online. Therefore, CF is assumed to equal availability and is 85 percent for NGCC cases.

The 555 (net) MWe NGCC plant was projected to have a Total Overnight Cost (TOC) of \$718/kWe, resulting in a COE of 58.9 mills/kWh.

**Table 3. Air Emissions Summary at 85% Capacity Factor**

Pollutant	NGCC Without CCS
<b>CO<sub>2</sub></b>	
• million tonnes/year	1.507
• lb/MWh <sub>net</sub>	804
<b>SO<sub>2</sub></b>	
• tonne/year	Negligible
• lb/MMBtu	Negligible
<b>NO<sub>x</sub></b>	
• tonne/year	115
• lb/MMBtu	0.009
<b>PM (filterable)</b>	
• tonne/year	Negligible
• lb/MMBtu	Negligible
<b>Hg</b>	
• tonne/year	Negligible
• lb/TBtu	Negligible

**Table 4 Major Financial Assumptions and Resulting Cost Summary<sup>1</sup>**

<b>Major Assumptions</b>			
Case:	<b>1x555 MWe net NGCC</b>		
Plant Size:	555.1 (MWe, net)	Heat Rate:	6,798 (Btu/kWh)
Primary/Secondary Fuel (type):	Natural Gas	Fuel Cost:	6.75 (\$/MMBtu)
Capital Expenditure Period:	3 (years)	Plant Life:	30 (years)
Cost Basis Year:	2007 (June)	Plant in Service:	2010 (June)
Capacity Factor:	85 (%)	Capital Charge Factor:	10.5 (%)
<b>Resulting Capital Investment (2007 dollars)</b>			<b>Mills/kWh</b>
Total Overnight Cost <sup>2</sup>			10.1
<b>Resulting Operating Costs (2007 dollars)</b>			<b>Mills/kWh</b>
Fixed Operating Cost			3.0
Variable Operating Cost			1.3
<b>Resulting Fuel Cost (2007 dollars) at \$1.80 / MMBtu</b>			<b>Mills/kWh</b>
			44.5
<b>Total Busbar Cost of Power (2007 dollars)</b>			<b>Mills/kWh</b>
			58.9

<sup>1</sup>Costs shown can vary -15%/+30%.

<sup>2</sup>Total overnight cost includes all equipment (complete with initial chemical and catalyst loadings), materials, labor (direct and indirect), engineering and construction management, and contingencies (process and project), and owner's cost.

### Contacts

**James Black**

General Engineer  
National Energy Technology Laboratory  
626 Cochrans Mill Road  
P.O. Box 10940  
Pittsburgh, PA 15236  
412-386-5458  
james.black@netl.doe.gov

**Larry Rath**

Director of Performance Division  
National Energy Technology Laboratory  
626 Cochrans Mill Road  
P.O. Box 10940  
Pittsburgh, PA 15236  
412-386-6871  
larry.rath@netl.doe.gov

#### References

Cost and Performance Baseline for Fossil Energy Plants, Vol. I. (2010, November). Pittsburgh, PA. DOE/NETL-2010/1397.

CoalFleet User Design Basis Specification for Coal-Based Integrated Gasification Combined Cycle (IGCC) Power Plants, (2009). EPRI, Palo Alto, CA. 1017501.



# Natural Gas Combined-Cycle Plant With Carbon Capture and Sequestration

## Plant Overview

This analysis is based on a 474 MWe (net power output) natural gas combined-cycle (NGCC) plant located at a greenfield site in the midwestern United States. This plant captures carbon dioxide (CO<sub>2</sub>) to be sequestered and is designed to meet Best Available Control Technology (BACT) emission limits. The combination process, heat, and mass balance diagram for the NGCC plant with carbon capture and sequestration (CCS) is shown in Figure 1. The primary fuel is natural gas (NG) with a higher heating value (HHV) of 22,600 Btu/lb. The plant is assumed to operate in baseload mode at a capacity factor (CF) of 85 percent without sparing for major train components. A summary of plant performance data for the NGCC plant with CCS case is presented in Table I.

Table I. Plant Performance Summary

Plant Type	NGCC
Carbon capture	Yes
Net power output (kWe)	473,570
Net plant efficiency (%)	42.8
Primary fuel (type)	Natural gas
COE (mills/kWh) @ 85% CF	85.9
TPC/TOC (\$/kW)	1,226/1,497
Cost of CO <sub>2</sub> avoided <sup>1</sup> (\$/tonne)	84/36
Analogous/Supercritical PC Ref.	

<sup>1</sup>The avoided costs for each capture case are calculated using the analogous non-capture plant as the reference and again with SC PC without CO<sub>2</sub> capture as the reference.

Figure 1. Process Flow Diagram NGCC With CCS

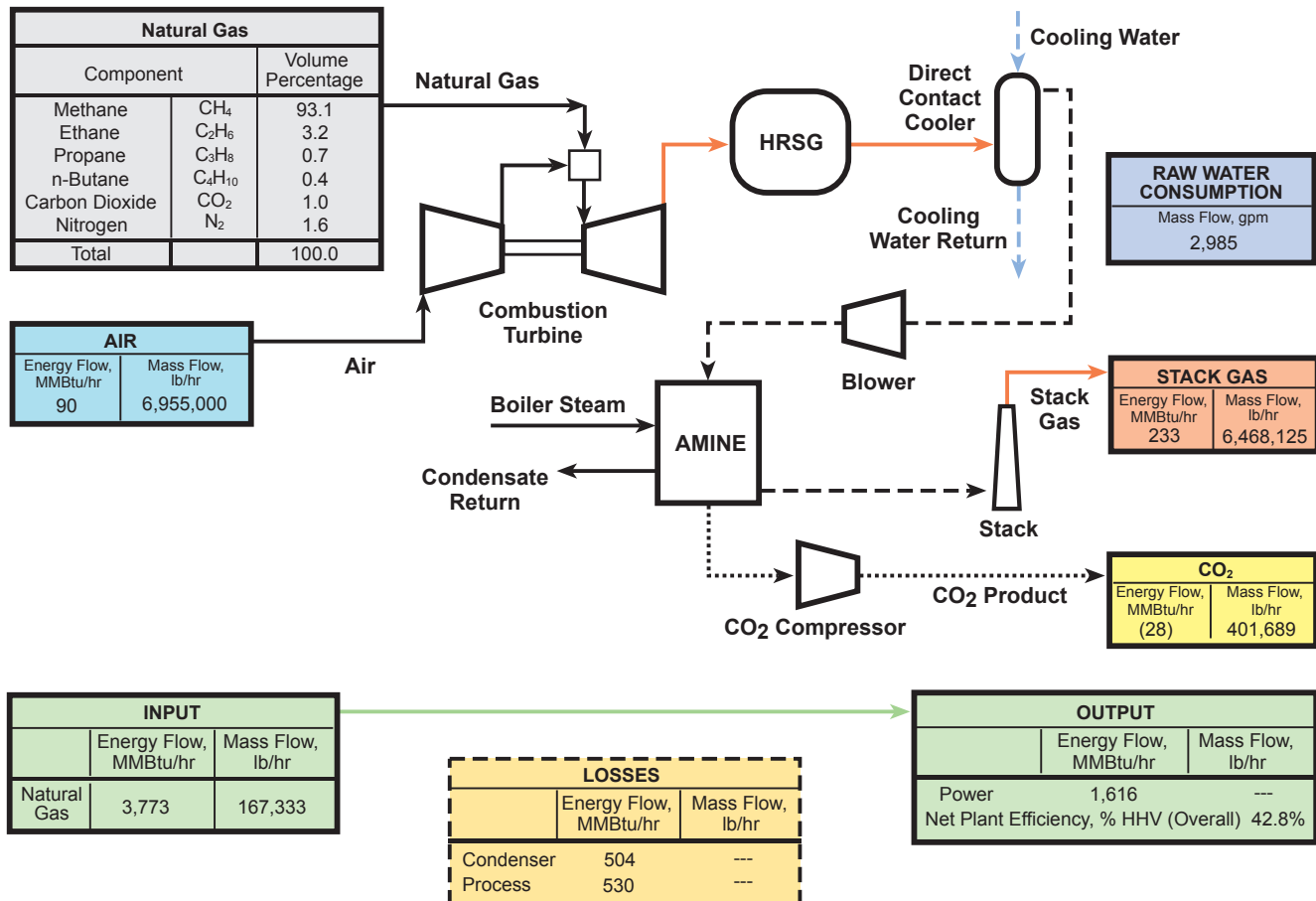

Note: Diagram is provided for general reference of major flows only. For complete flow information, please refer to the final report.

## Technical Description

The analysis for the NGCC plant with CCS is based on two advanced F-Class combustion turbine generators (CTG) that are assumed to be commercially available to support startup in 2010, two heat recovery steam generators (HRSG), and one steam turbine generator (STG) in a multi-shaft 2x2x1 configuration with a recirculating wet cooling tower for cycle heat rejection.

The unit consists of an NG system that feeds NG at the required pressure and temperature to the two axial-flow, constant-speed CTGs with variable inlet guide vanes and a dry low-NOx (DLN) burner combustion system. Each CTG exhausts to an HRSG configured with high-, intermediate-, and low-pressure steam systems including drum, superheater, reheater, and economizer sections. Steam flows from both HRSGs to a conventional STG for power generation. The Rankine cycle consists of a single reheat system with steam conditions of 16.5 MPa/566°C/566°C (2,400 psig/1,050°F/1,050°F). Nitrogen oxide (NOx) emissions are controlled to 25 ppmvd (referenced to 15 percent oxygen (O<sub>2</sub>)) by the DLN combustion system and then further reduced by a selective catalytic reduction (SCR) system. The SCR system was designed for 90 percent NOx reduction. The DLN burner, together with the SCR system, achieves the emission limit of 2.5 ppmvd (referenced to 15 percent O<sub>2</sub>). All other support systems and equipment are typical for a conventional NGCC plant. Plant performance is based on the properties of pipeline-quality NG.

Flue gas (FG) exiting the HRSGs is directed to the Fluor Econamine FG Plus™ process where CO<sub>2</sub> is absorbed in a monoethanolamine-based solvent. A booster blower is required to overcome the process pressure drop. Carbon dioxide removed in the Econamine FG Plus™ process is dried and compressed for subsequent pipeline transport and sequestration. The CO<sub>2</sub> is delivered to the plant fence line at 15.3 MPa (2,215 psia). The compressed CO<sub>2</sub> is transported via pipeline to a geologic sequestration field for injection into a saline aquifer, which is located within 50 miles of the plant.

Achieving a nominal 474 MWe net output with the above plant configuration results in a thermal input requirement of 1,106 MWt. This thermal input is achieved by burning NG at a rate of 167,333 lb/hr, which yields a net plant heat rate of 7,968 Btu/kWh (HHV-basis efficiency of 42.8 percent). The gross power output of 511 MWe is produced from the advanced CTGs and the STG.

With an auxiliary power requirement of 37.4 MWe, the net plant output is 474 MWe. The summary of plant electrical generation performance is presented in Table 2.

Table 2. Plant Electrical Generation

	Electrical Summary
Advanced gas turbine x 2, MWe	362.2
Steam turbine, MWe	148.8
Gross power output, MWe	511.0
Auxiliary power requirement, MWe	(37.4)
Net power output, MWe	473.6

## Environmental Performance

This study assumes the use of BACT to meet the emission requirements of the 2006 New Source Performance Standards.

NGCC plants use NG as their fuel, which creates negligible emissions of sulfur dioxide (SO<sub>2</sub>), particulate matter (PM), and mercury (Hg); therefore, NGCC plants require no emissions control equipment or features to reduce these emissions. NOx emissions are controlled to 25 ppmvd (referenced to 15 percent O<sub>2</sub>) by the DLN combustion system and then further reduced by an SCR system. The SCR system was designed for 90 percent NOx reduction while firing NG. The low NOx burner, together with the SCR, achieves the emission limit of 2.5 ppmvd (referenced to 15 percent O<sub>2</sub>).

CO<sub>2</sub> capture is designed to recover 90 percent of the CO<sub>2</sub> in the FG stream by the Econamine FG Plus™ process.

A summary of the resulting air emissions is presented in Table 3.

### Cost Estimation

Estimates of capital and operations costs were developed for each plant based on adjusted vendor-furnished and actual cost data from recent design/build projects. These costs were used to calculate a first year cost-of-electricity (COE) based on the power plant costs and assumed financing structure. Financial assumptions and a cost summary are shown in Table 4.

Project contingencies were added to each case to cover project uncertainty and the cost of any additional equipment that could result from detailed design. The project contingencies represent costs that are expected to occur. Project contingency was 10.8 percent of the Total Plant Cost (TPC).

Process contingency is intended to compensate for uncertainties arising as a result of the state of technology development. Process contingencies represent 4 percent of the NGCC CCS case TPC and have been applied to the estimates as follows:

- CO<sub>2</sub> Removal System – 20 percent on all NGCC CCS cases
- Instrumentation and Controls – 5 percent on the NGCC CCS cases

This study assumes that each new plant would be dispatched any time it is available and would be capable of generating maximum capacity when online. Therefore, CF is assumed to equal availability and is 85 percent for NGCC cases. The assumed CF for NGCC cases is 85 percent.

For the NGCC cases that feature CCS, capital and operating costs were estimated for transporting CO<sub>2</sub> to an underground storage area, associated storage maintenance, and for monitoring beyond the expected life of the plant.

The 474 (net) MWe NGCC plant with CCS was projected to have a Total Overnight Cost (TOC) of \$1,497/kWe, resulting in a COE of 85.9 mills/kWh.

Table 3 Air Emissions Summary at 85% Capacity Factor

Pollutant	NGCC With CCS
<b>CO<sub>2</sub></b>	
• million tonnes/year	0.151
• lb/MWh <sub>net</sub>	94
<b>SO<sub>2</sub></b>	
• tonne/year	Negligible
• lb/MMBtu	Negligible
<b>NO<sub>x</sub></b>	
• tonne/year	105
• lb/MMBtu	0.008
<b>PM (filterable)</b>	
• tonne/year	Negligible
• lb/MMBtu	Negligible
<b>Hg</b>	
• tonne/year	Negligible
• lb/TBtu	Negligible

Table 4. Major Financial Assumptions and Resulting Cost Summary<sup>1</sup>

<b>Major Assumptions</b>			
Case:	<b>1x474 MWe net NGCC with CCS</b>		
Plant Size:	473.6 (MWe, net)	Heat Rate:	7,968 (Btu/kWh)
Primary/Secondary Fuel (type):	Natural Gas	Fuel Cost:	6.55 (\$/MMBtu)
Capital Expenditure Period:	3 (years)	Plant Life:	30 (years)
Cost Basis Year:	2007 (June)	Plant in Service:	2010 (June)
Capacity Factor:	85 (%)	Capital Charge Factor:	11.1 (%)
<b>Resulting Capital Investment (2007 dollars)</b>			<b>Mills/kWh</b>
Total Plant Cost <sup>2</sup>			22.3
<b>Resulting Operating Costs (2007 dollars)</b>			<b>Mills/kWh</b>
Fixed Operating Cost			5.7
Variable Operating Cost			2.6
<b>Resulting Fuel Cost (2007 dollars) @ \$1.80 / MMBtu</b>			<b>Mills/kWh</b>
			52.2
<b>Resulting CO<sub>2</sub> Cost (2007 dollars)</b>			<b>Mills/kWh</b>
			3.2
<b>Total Busbar Cost of Power (2007 dollars)</b>			<b>Mills/kWh</b>
			85.9

<sup>1</sup>Costs shown can vary -15%/+30%.

<sup>2</sup>Total overnight cost includes all equipment (complete with initial chemical and catalyst loadings), materials, labor (direct and indirect), engineering and construction management, and contingencies (process and project), and owner's cost.

### Contacts

**James Black**

General Engineer  
 National Energy Technology Laboratory  
 626 Cochrans Mill Road  
 P.O. Box 10940  
 Pittsburgh, PA 15236  
 412-386-5458  
 james.black@netl.doe.gov

**Larry Rath**

Director of Performance Division  
 National Energy Technology Laboratory  
 626 Cochrans Mill Road  
 P.O. Box 10940  
 Pittsburgh, PA 15236  
 412-386-6871  
 larry.rath@netl.doe.gov

References

Cost and Performance Baseline for Fossil Energy Plants, Vol. 1. (2010, November). Pittsburgh, PA. DOE/NETL-2010/1397.

CoalFleet User Design Basis Specification for Coal-Based Integrated Gasification Combined Cycle (IGCC) Power Plants, (2009). EPRI, Palo Alto, CA. 1017501.



## **National Energy Technology Laboratory**

1450 Queen Avenue SW  
Albany, OR 97321-2198  
541-967-5892

2175 University Avenue South, Suite 201  
Fairbanks, AK 99709  
907-452-2559

3610 Collins Ferry Road  
P.O. Box 880  
Morgantown, WV 26507-0880  
304-285-4764

626 Cochrans Mill Road  
P.O. Box 10940  
Pittsburgh, PA 15236-0940  
412-386-4687

13131 Dairy Ashford, Suite 225  
Sugar Land, TX 77478  
281-494-2516

WEBSITE: [www.netl.doe.gov](http://www.netl.doe.gov)

CUSTOMER SERVICE: **1-800-553-7681**



U.S. DEPARTMENT OF  
**ENERGY**