

**SPILLWAY ASSEMBLY WITH DOWN DRAIN  
OUTLET ON NON-ERODIBLE MATERIAL**

**SPILLWAY ASSEMBLY WITH DOWN DRAIN  
OUTLET ON ERODIBLE MATERIAL**

**NOTE:**

1. Fabricate spillway assembly from annular corrugated pipe, or from helically corrugated pipe with factory annular or reformed ends. Use 1.6 mm galvanized steel or 1.5 mm aluminum.
2. Make all banded connections water tight by placing 5 mm bead of approved caulking under each half of the band before tightening.
3. Payment for Tee Branch connection under Section 602 is included in the linear measurement for culvert pipe for the applicable sizes. Measure Tee Branch connections along the top of the Tee.
4. Place class 2 riprap conforming to Section 251 for protective apron.
5. Approved alternate designs may be used.
6. See Detail WM606-14 for Pipe Anchor Assembly Detail.
7. Furnish hardware in the metric sizes shown. Equivalent US Customary sizes may be used when metric sizes are unavailable.
8. Dimensions without units are millimeters.

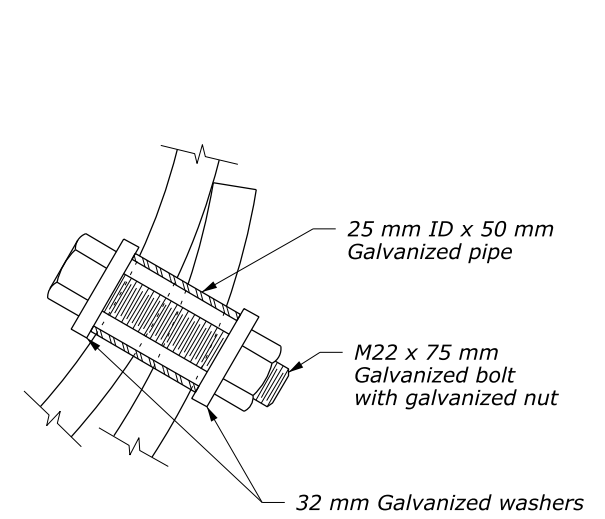

**BOLT DETAIL**

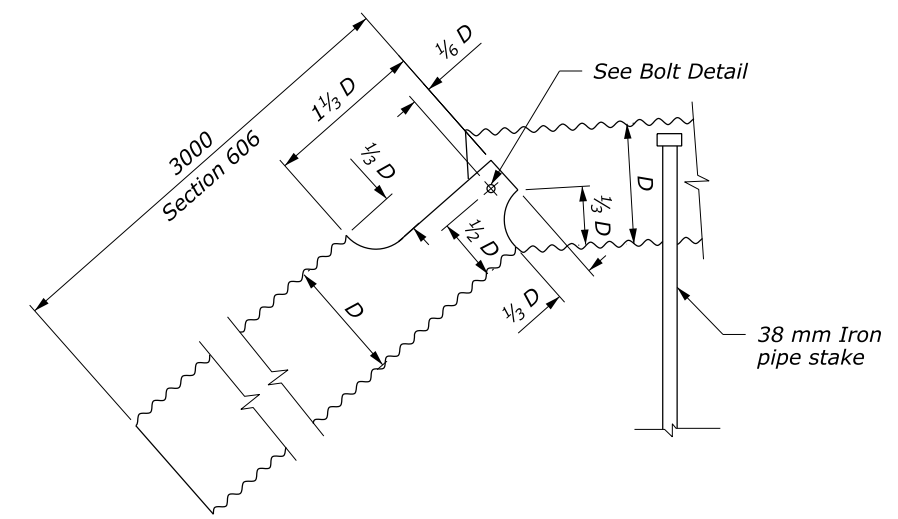

**SPILLWAY ASSEMBLY**

D= Diameter of culvert

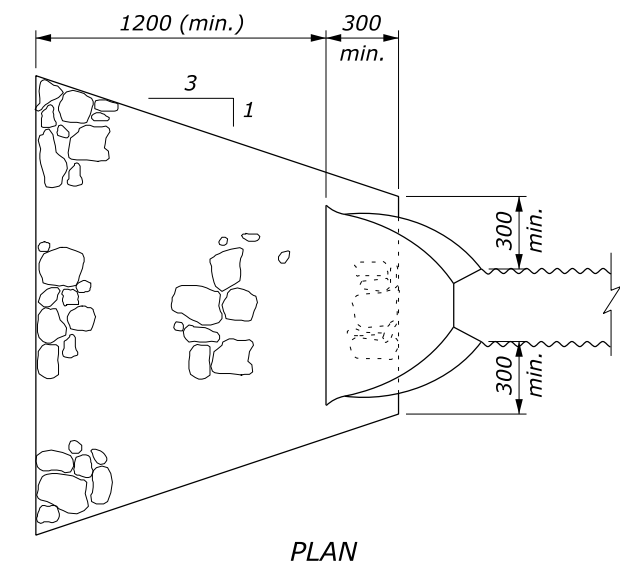

**PROTECTIVE APRON**

U.S. DEPARTMENT OF TRANSPORTATION FEDERAL HIGHWAY ADMINISTRATION WESTERN FEDERAL LANDS HIGHWAY DIVISION	
METRIC DETAIL	
<b>SPILLWAY ASSEMBLY WITH DOWN DRAIN</b>	
DETAIL APPROVED FOR USE 4/2009	DETAIL
REVISED: 9/2011	WM606-10

NO SCALE