



NATIONAL AERONAUTICS AND SPACE ADMINISTRATION  
WASHINGTON, D.C. 20546

TELS. WO 2-4155  
WO 3-6925

**FOR RELEASE:** WEDNESDAY P.M.  
November 5, 1969

RELEASE NO: 69-148



**PROJECT:** APOLLO 12  
(To be launched no  
earlier than Nov. 14)

**P  
R  
E  
S  
S  
  
K  
I  
T**

**contents**

GENERAL RELEASE-----1-6  
 APOLLO 12 COUNTDOWN-----7-9  
 LAUNCH, MISSION TRAJECTORY AND MANEUVER DESCRIPTION-----10  
   Launch-----10-11  
   Launch Events-----12  
   Apollo 12 Mission Events-----13-18  
   Earth Parking Orbit (EPO)-----19  
   Translunar Injection (TLI)-----19  
   Transposition, Docking and Ejection (TD&E)-----19  
   Translunar Coast-----19-20  
   Lunar Orbit Insertion (LOI)-----20  
   Lunar Module Descent Lunar Landing-----20-21  
   Powered Descent Events-----22  
   Lunar Surface Exploration-----23-24  
   Ascent, Lunar Orbit Rendezvous-----25  
   Ascent Stage Deorbit-----26  
   Transearth Injection (TEI)-----26  
   Transearth Coast-----26  
   Entry, Landing-----26

DEDICATION

This press kit is dedicated to the memory of Science Editor William J. Perkinson of The Baltimore Evening Sun and Reporter/Columnist John B. Wilson of The Minneapolis Tribune, who covered the United States space program from its inception through the Apollo 11 lunar landing mission.

Recovery Operations-----	27
APOLLO 12 ONBOARD TELEVISION-----	28
Apollo 12 TV Schedule-----	29
APOLLO 12 SCIENTIFIC EXPERIMENTS-----	30
Lunar Surface Magnetometer (LSM)-----	30-32
Lunar Ionosphere Detector (LID)-----	32-33
Lunar Atmosphere Detector (LAD)-----	33-34
Solar Wind Spectrometer-----	34-35
Solar Wind Composition Experiment (SWCE)-----	36
Field Geology Investigations-----	37-39
Passive Seismic Experiment (PSE)-----	40-41
Dust Detector-----	42
Lunar Multispectral Photography Experiment S-158-----	43
SNAP-27-----	44-45
PHOTOGRAPHIC EQUIPMENT-----	46-47
LUNAR DESCRIPTION-----	48
Physical Facts-----	48-49
Apollo 12 Landing Site-----	49
SATURN V LAUNCH VEHICLE-----	50
First Stage-----	50
Second Stage-----	50
Third Stage-----	50
Instrument Unit-----	51
Propulsion-----	51-52
COMMAND AND SERVICE MODULE STRUCTURE, SYSTEMS-----	53
Launch Escape System-----	53
Command Module Structure-----	53
Service Module Structure-----	53
Spacecraft-LM Adapter (SLA) Structure-----	54
CSM Systems-----	54-57
LUNAR MODULE STRUCTURES, WEIGHT-----	58
Ascent Stage-----	58
Descent Stage-----	59-63
APOLLO 12 CREW-----	64
Life Support Equipment - Space Suits-----	64-65
Apollo Lunar Hand Tools-----	66-68
Apollo 12 Crew Menu-----	69-70
Personal Hygiene-----	71
Medical Kit-----	71
Survival Gear-----	71-72
Biomedical Inflight Monitoring-----	72
Training-----	73-74
Crew Biographies-----	75-80
LAUNCH COMPLEX 39-----	81-83
MISSION CONTROL CENTER-----	84-86
MANNED SPACE FLIGHT NETWORK-----	87-89
Network Computers-----	89-90
Lunar Receiving Laboratory (LRL)-----	91-93

LUNAR RECEIVING LABORATORY TENTATIVE SCHEDULE-----	94-95
CONTAMINATION CONTROL PROGRAM-----	96-97
SCHEDULE FOR TRANSPORT OF SAMPLES, SPACECRAFT AND CREW-----	98
APOLLO PROGRAM MANAGEMENT-----	99
Apollo/Saturn Officials-----	100-102
Major Apollo/Saturn V Contractors-----	103-104

NEWS



---

NATIONAL AERONAUTICS AND SPACE ADMINISTRATION (202) 962-4155  
WASHINGTON, D.C. 20546      TELS: (202) 963-6925

---

**FOR RELEASE:** WEDNESDAY P.M.  
November 5, 1969

RELEASE NO: 69-148

APOLLO 12 LAUNCH NOV. 14

Apollo 12, the second United States manned lunar landing mission will be launched November 14 from the John F. Kennedy Space Center, Fla., to continue lunar exploration begun last July by the Apollo 11 crew.

Stay time on the Moon will be approximately 10 hours longer than on the first landing last July and the lunar module crew will leave the spacecraft twice to set up scientific experiments and make geological investigations.

Crewmen are commander Charles Conrad, Jr., command module pilot Richard F. Gordon, Jr., and lunar module pilot Alan L. Bean. All are U.S. Navy Commanders.

Primary objectives of Apollo 12 are:

\*Perform selenological inspection, survey and sampling in a lunar mare area;

\*Deploy an Apollo Lunar Surface Experiments Package (ALSEP) consistent with a seismic net;

-more-

10/29/69

- \*Develop techniques for a point landing capability;
- \*Develop man's capability to work in the lunar environment; and
- \*Obtain photographs of candidate exploration sites.

The Apollo 12 landing site is on the western side of the visible face of the Moon in the Ocean of Storms at 2.94° South latitude, 23.45° West longitude -- about 830 nautical miles west of Apollo 11's landing site in the Sea of Tranquillity.

The Apollo 12 landing site is designated Site 7.

Experiments in ALSEP 1 will gather and relay long-term scientific and engineering data to Earth for at least a year on the Moon's physical and environmental properties. Six experiments are contained in the ALSEP: lunar passive seismometer for measuring and relaying meteoroid impacts and moonquakes; magnetometer for measuring the magnetic field at the lunar surface; solar wind device for monitoring the interaction of solar wind particles with the Moon; lunar ionosphere detector for measuring flux, energy and velocity of positive ions in the lunar ionosphere; lunar atmosphere detector for measuring minute changes in the ambient lunar atmosphere density; and lunar dust detector for measuring of dust accretion on ALSEP.

During the second of two Extra Vehicular Activity (EVA) periods Conrad and Bean will perform extensive lunar geological investigations and surveys.

A secondary objective is to retrieve portions of the Surveyor III spacecraft which have been exposed to the lunar environment since the unmanned spacecraft soft-landed on the inner slope of a crater April 20, 1967. Inspection and sample collection at the Surveyor landing site will be done during the second EVA period in which Conrad and Bean will make an extended geology traverse. The opportunity to perform this secondary objective is dependent on the LM landing close enough for a traverse to the Surveyor III site.

After the lunar surface phase is complete, a plane-change maneuver with the service propulsion engine will bring the command module over three candidate Apollo landing sites -- Fra Mauro, Descartes and Lalande. Extensive photographic coverage will be obtained of these sites for assessment as potential landing points for later Apollo missions.

The flight profile of Apollo 12 in general follows that flown by Apollo 11 with two exceptions: Apollo 12 will have a higher inclination to the lunar equator and will leave the free-return trajectory at midcourse correction No. 2.

Going to a non free-return or hybrid trajectory permits a daylight launch, translunar injection over the Pacific Ocean, stretches out the translunar coast to gain the desired landing site lighting at the time of LM landing, and conserves fuel. Also, the non free-return allows the 210-foot Goldstone, Calif., tracking antenna to cover the LM descent and landing.

A second launch window for the Apollo 12 opens on Nov. 16 for lunar landing Site 5.

Lunar orbit insertion will be made in two phases--one maneuver into a 60x170 nm elliptical orbit, the second maneuver to a more circular orbit of 54x66 nm.

Lunar surface touchdown should take place at 1:53 a.m. EST Nov. 19, and two periods of extravehicular activity are planned at 5:55 a.m. EST Nov. 19 and 12:29 a.m. EST Nov. 20. The LM ascent stage will lift off at 9:23 a.m. Nov. 20 to rejoin the orbiting command module after nearly 32 hours on the lunar surface.

Apollo 12 will leave lunar orbit at 3:43 p.m. EST Nov. 21 for return to Earth. Splashdown in the mid-Pacific just south of the Equator will be at 3:57 p.m. EST Nov. 24.

After the spacecraft has landed, the crew will don biological isolation garments and transfer by helicopter to a Mobile Quarantine Facility (MQF) on the U.S.S. Hornet's hangar deck. Sealed in the Mobile Quarantine Facility, the crew and support technicians will be offloaded at Pearl Harbor, Hawaii, for an aircraft-and-truck trip to the Lunar Receiving Laboratory at the NASA Manned Spacecraft Center in Houston.

The crew will remain in quarantine for 21 days from completion of the second EVA.

The crew of Apollo 12 selected the call signs for the spacecraft - command module "Yankee Clipper" and lunar module "Intrepid" - from a list of several thousand names submitted by employees of command module and lunar module prime contractors.

The crew will emplace an American flag on the lunar surface. A plaque bearing the date of the Apollo 12 landing and the astronauts' signatures is attached to the LM.

Additionally, flags of 136 nations, UN Organization, 50 United States and four U.S. possessions will be aboard the lunar module for Apollo 12.



Apollo 12 backup crew members are USAF Col. David R. Scott, commander; USAF Maj. Alfred M. Worden, command module pilot; and USAF Lt. Col. James B. Irwin, lunar module pilot.

(END OF GENERAL RELEASE; BACKGROUND INFORMATION FOLLOWS)

-more-

APOLLO 12 COUNTDOWN

The official countdown for Apollo 12 will begin at T-28 hours and will continue to T-9 hours at which time a built-in hold is planned prior to the start of launch vehicle propellant loading.

Precount activities begin at T-4 days, 2 hours when the space vehicle will be prepared for the start of the official countdown. During precount, final space vehicle ordnance installation and electrical connections will be accomplished. Spacecraft gaseous oxygen and gaseous helium systems will be serviced, spacecraft batteries will be installed, and LM and CSM mechanical buildup will be completed. The CSM fuel cells will be activated and CSM cryogenics (liquid oxygen - liquid hydrogen) will be loaded and pressurized.

Following are some of the major operations in the final count:

T-28 hours	Official countdown starts LM crew stowage and cabin adjustment (T-31:00 to T-28:00)
T-27 hours, 30 minutes	Install and connect LV flight batteries (to T-23 hours)
T-22 hours, 30 minutes	Topoff of LM super critical helium (to T-20 hours, 30 minutes)
T-19 hours, 30 minutes	LM SHe thermal shield installation (to T-15 hours, 30 minutes) CSM crew stowage (T-19 to T-12 hours, 30 minutes)
T-16 hours	LV range safety checks (to T-15 hours)
T-15 hours	Installation of ALSEP FCA (to T-14 hours, 45 minutes)
T-11 hours, 30 minutes	Connect LV safe and arm devices (to 10 hours, 45 minutes) CSM pre-ingress operations (to T-8 hours 45 minutes)
T-10 hours, 15 minutes	Start MSS move to parksite

-more-

T-9 hours	Built-in hold for 9 hours and 22 minutes. At end of hold, pad is cleared for LV propellant loading
T-8 hours, 05 minutes	Launch vehicle propellant loading - Three stages (LOX in first stage, LOX and LH <sub>2</sub> in second and third stages). Continues thru T-3 hours 38 minutes
T-4 hours, 17 minutes	Flight crew alerted
T-4 hours, 02 minutes	Medical examination
T-3 hours, 32 minutes	Breakfast
T-3 hours, 30 minutes	One-hour hold
T-3 hours, 07 minutes	Depart Manned Spacecraft Operations Building for LC-39 via crew transfer van.
T-2 hours, 55 minutes	Arrive at LC-39
T-2 hours, 40 minutes	Start flight crew ingress
T-2 hours	Mission Control Center - Houston/ spacecraft command checks
T-1 hour, 55 minutes	Abort advisory system checks
T-1 hour, 51 minutes	Space Vehicle Emergency Detection System (EDS) test
T-43 minutes	Retract Apollo access arm to standby position (12 degrees)
T-42 minutes	Arm launch escape system
T-40 minutes	Final launch vehicle range safety checks (to 35 minutes)
T-30 minutes	Launch vehicle power transfer test LM switch over to internal power
T-20 minutes to T-10 minutes	Shutdown LM operational instrumentation
T-15 minutes	Spacecraft to internal power
T-6 minutes	Space vehicle final status checks

T-5 minutes, 30 seconds	Arm destruct system
T-5 minutes	Apollo access arm fully retracted
T-3 minutes, 6 seconds	Firing command (automatic sequence)
T-50 seconds	Launch vehicle transfer to internal power
T-8.9 seconds	Ignition sequence start
T-2 seconds	All engines running
T-0	Liftoff

Note: Some changes in the above countdown are possible as a result of experience gained in the countdown demonstration test which occurs about 10 days before launch.

## LAUNCH, MISSION TRAJECTORY AND MANEUVER DESCRIPTION

Information presented here is based upon an on-time Nov. 14 launch and is subject to change prior to the mission or in real-time during the mission to meet changing conditions.

### Launch

Saturn V launch vehicle will launch the Apollo 12 spacecraft from Launch Complex 39A, NASA-Kennedy Space Center, Fla., on an azimuth that can vary from 72 to 96 degrees, depending upon the time of day of launch. The azimuth changes with launch time to permit a fuel-optimum injection from Earth parking orbit into a free-return circumlunar trajectory and proper Sun angles at the lunar landing site.

November 14 launch plans call for liftoff at 11:22 a.m. EST on an azimuth of 72 degrees. The vehicle will reach an altitude of 36 nm before first stage cutoff 51 nm downrange. During the 2 minutes 42 seconds of powered flight, the first stage will increase vehicle velocity to 9,059 fps (5,363 knots). First stage thrust will reach a maximum of 9,042,041 pounds before center engine cutoff. After engine shutdown and separation from the second stage, the booster will fall into the Atlantic Ocean about 364 nm downrange from the launch site (30 degrees North latitude and 74 degrees West longitude) approximately 9 minutes 14 seconds after liftoff.

The 1-million-pound thrust second stage (S-II) will carry the space vehicle to an altitude of 102 nm and a distance of 884 nm downrange. At engine burnout, the vehicle will be moving at a velocity of 22,889 fps. The outer J-2 engines will burn 6 minutes 26 seconds during the powered phase, but the center engine will be cut off at 4 minutes 57 seconds after S-II ignition.

At outboard engine cutoff, the S-II will separate and, following a ballistic trajectory, plunge into the Atlantic Ocean about 2,419 nm downrange from the Kennedy Space Center (31 degrees North latitude and 34 degrees West longitude) some 20 minutes 24 seconds after liftoff.

The first burn of the Saturn V third stage (S-IVB) begins about 4 seconds after S-II stage separation. It will last long enough (135 seconds) to insert the space vehicle into a circular Earth parking orbit beginning at about 1,429 nm downrange. Velocity at Earth orbital insertion will be 25,567 fps at 11 minutes 39 seconds ground elapsed time (GET). Inclination will be 33 degrees to the equator.

The crew will have a backup to launch vehicle guidance during powered flight. If the Saturn instrument unit inertial platform fails, the crew can switch guidance to the command module systems for first-stage powered flight automatic control. Second and third stage backup guidance is through manual takeover in which crew hand controller inputs are fed through the command module computer to the Saturn instrument unit.

LAUNCH EVENTS

Time		Event	Altitude Feet	Velocity Ft/Sec	Range Nau. Mi.
Hrs	Min Sec				
00	00 00	First Motion	198	1,340	0
00	01 23	Maximum Dynamic Pressure	44,250	2,702	3
00	02 15	S-IC Center Engine Cutoff	143,972	6,454	25
00	02 42	S-IC Outboard Engines Cutoff	222,090	9,058	51
00	02 43	S-IC/S-II Separation	224,529	9,089	52
00	02 44	S-II Ignition	229,619	9,075	52
00	03 13	S-II Aft Interstage Jettison	310,032	9,485	88
00	03 18	LET Jettison	324,151	9,588	95
00	07 41	S-II Center Engine Cutoff	608,352	17,582	603
00	09 11	S-II Outboard Engines Cutoff	623,592	22,888	884
00	09 12	S-II/S-IVB Separation	623,782	22,897	887
00	09 15	S-IVB Ignition	624,326	22,898	898
00	11 30	S-IVB First Cutoff	627,958	25,562	1,390
00	11 40	Parking Orbit Insertion	627,981	25,567	1,429
02	47 20	S-IVB Reignition	644,318	25,559	5,716
02	53 5	S-IVB Second Cutoff	1,162,582	35,426	4,165
02	53 15	Translunar Injection	1,214,454	35,394	4,112

APOLLO 12 MISSION EVENTS

<u>Event</u>	<u>GET</u> hrs.:min.	<u>Date/EST</u>	<u>Vel. Change</u> feet/sec	<u>Purpose and Resultant Orbit</u>
Earth orbit insertion	00:11	14 11:34 a.m.	25,567	Insertion into 103 nm circular Earth parking orbit.
Translunar injection (S-IVB engine ignition)	02:47	14 2:09 p.m.	9,859	Injection into free-return translunar trajectory with 1,850 nm pericyynthion
CSM separation, docking	03:28	14 2:50 p.m.	--	Hard-mating of CSM and LM
Ejection from SLA	04:13	14 3:35 p.m.	1	Separates CSM-LM from S-IVB-SLA
S-IVB Evasive maneuver	04:25	14 3:47 p.m.	10	Provides separation prior to S-IVB propellant dump and "slingshot" maneuver
Midcourse correction #1	TLI+9 hrs	14 11:09 p.m.	*0	*These midcourse corrections have a nominal velocity change of 0 fps, but will be calculated in real time to correct TLI dispersions. MCC-2 is an SPS maneuver (64 fps) to lower pericyynthion to 60 nm; trajectory then becomes non-free return.
Midcourse correction #2 (Hybrid transfer)	30:53	15 6:15 p.m.	64	
Midcourse correction #3	LOI-22 hrs	16 00:47 a.m.	*0	
Midcourse correction #4	LOI-5 hrs	17 5:47 p.m.	*0	
Lunar orbit insertion #1	83:25	17 10:47 p.m.	-2890	Inserts Apollo 12 into 60x170 nm elliptical lunar orbit
Lunar orbit insertion #2	87:44	18 3:06 a.m.	-169	Changes lunar parking orbit to 54x66 nm

--more--



APOLLO 12 MISSION EVENTS

<u>Event</u>	<u>GET</u>	<u>Date/EST</u>	<u>Vel. Change</u>	<u>Purpose and Resultant Orbit</u>
CSM-LM undocking	107:58	18 11:20 p.m.	--	Establishes equiperiod orbit for 2.2 nm separation at DOI maneuver
Separation (SM RCS)	108:28	18 11:49 p.m.	2.5	
Descent orbit insertion	109:23	19 00:45 a.m.	-72	Lowers LM pericyynthion to 8 nm (8x60)
LM powered descent initiation (DPS)	110:20	19 1:42 a.m.	-6779	Three-phase maneuver to brake LM out of transfer orbit, vertical descent and touchdown on lunar surface
LM touchdown on lunar surface	110:31	19 1:53 a.m.		Lunar exploration, deploy ALSEP, lunar surface geological sample collection, photography, possible Surveyor III investigation
Depressurization for 1st lunar surface EVA	114:33	19 5:55 a.m.		
CDR steps to surface	114:47	19 6:09 a.m.		
CDR collects contingency samples	114:54	19 6:16 a.m.		
LMP steps to surface	115:14	19 6:36 a.m.		
CDR unstows and erects S-Band antenna	115:20	19 6:42 a.m.		
LMP mounts TV camera on tripod	115:26	19 6:48 a.m.		

-more-

APOLLO 12 MISSION EVENTS

<u>Event</u>	<u>GET</u>	<u>Date/EST</u>	<u>Vel. Change</u>	<u>Purpose and Resultant Orbit</u>
LMP deploys solar wind experiment	115:33	19 6:55 a.m.		
CDR and LMP begin unstowing and deployment of ALSEP	115:46	19 7:08 a.m.		
CDR and LMP return to LM collecting samples and retrieving TV camera on route	117:00	19 8:22 a.m.		
CDR and LMP arrive back at LM, stow equipment and samples	117:17	19 8:39 a.m.		
LMP reenters LM	117:33	19 8:55 a.m.		
CDR reenters LM	117:53	19 9:15 a.m.		
LM hatch closed and repressurize	117:58	19 9:20 a.m.		
Depressurization for 2nd lunar surface EVA	133:07	20 00:29 a.m.		
CDR steps to surface	133:13	20 00:35 a.m.		
LMP steps to surface	133:20	20 00:42 a.m.		
Begin field geology traverse & collect core tube & gas analysis sample	133:30	20 00:52 a.m.		

APOLLO 12 MISSION EVENTS

<u>Event</u>	<u>GET</u>	<u>Date/EST</u>	<u>Vel. Change</u>	<u>Purpose and Resultant Orbit</u>
Walk to Surveyor Site, observe, photograph & retrieve parts	135:00	20 2:22 a.m.		
Complete geology traverse	135:30	20 2:52 a.m.		
Return to LM area retrieve solar wind experiment; stow surface samples	135:45	20 3:07 a.m.		
LMP enters LM	135:59	20 3:21 a.m.		
CDR transfers samples LMP assists	136:09	20 3:31 a.m.		
CDR enters LM and closes hatch	136:24	20 3:46 a.m.		
Cabin repressurization	136:30	20 3:52 a.m.		
LM ascent	142:01	20 9:23 a.m.	6049	Boosts ascent stage into 9x45 lunar orbit for rendezvous with CSM
Insertion	142:08	20 9:30 a.m.		
LM RCS concentric sequence initiation (CSI) burn	142:58	20 10:20 a.m.	50	Raises LM perilune to 44.7 nm, adjusts orbital shape for rendezvous sequence (47x45)

more

APOLLO 12 MISSION EVENTS

<u>Event</u>	<u>GET</u>	<u>Date/EST</u>	<u>Vel. Change</u>	<u>Purpose and Resultant Orbit</u>
LM RCS constant delta height (CDH) burn	143:56	20 11:18 a.m.	4.4	Radially downward burn adjusts LM orbit to constant 15 nm below CSM
LM RCS terminal phase initiation (TPI) burn	144:36	20 11:58 a.m.	24.8	LM thrusts along line of sight toward CSM, midcourse and braking maneuvers as necessary
Rendezvous (TPF)	145:21	20 12:43 p.m.	31.7	Completes rendezvous sequence (59.5x59.0)
Docking	145:40	20 1:02 p.m.	--	Commander and LM pilot transfer back to CSM
LM jettison, separation (SM RCS)	147:21	20 2:43 p.m.	1.5	Prevents recontact of CSM with LM ascent stage during remainder of lunar orbit
LM ascent stage deorbit (APS)	149:28	20 4:50 p.m.	-200	Seismometer calibration
LM ascent stage impact	149:56	20 5:18 p.m.	--	Impact at about 5500 fps, at 4° angle 5 nm from ALSEP
Plane change for photos	159:02	21 2:24 a.m.		
Transearth injection (TEI) SPS	172:21	21 3:43 p.m.	3113	Inject CSM into transearth trajectory
Midcourse correction #5	187:21	22 6:43 a.m.	0	Transearth midcourse corrections will be computed in real time for entry corridor control and recovery area weather avoidance.
Midcourse correction #6	EI-22 hrs	23 5:49 p.m.	0	
Midcourse correction #7	EI-3 hrs	24 12:49 p.m.	0	

APOLLO 12 MISSION EVENTS

<u>Event</u>	<u>GET</u>	<u>Date/EST</u>	<u>Vel. Change</u>	<u>Purpose and Resultant Orbit</u>
CM/SM separation	244:11	24 3:34 p.m.	---	Command module oriented for entry
Entry interface (400,000 feet)	244:26	24 3:43 p.m.	---	Command module enters Earth's sensible atmosphere at 36,129 fps
Splashdown	244:35	24 3:57 p.m.	---	Landing 1250 nm downrange from entry, 16° south latitude by 165° west longitude. (Local time -- 9:57 a.m.) Sunrise + 5 hours.

### Earth Parking Orbit (EPO)

Apollo 12 will remain in Earth parking orbit for one and one-half revolutions. The final "go" for the TLI burn will be given to the crew through the Carnarvon, Australia, Manned Space Flight Network station.

### Translunar Injection (TLI)

Midway through the second revolution in Earth parking orbit, the S-IVB third-stage engine will restart at 2:47 GET over the mid-Pacific Ocean near the equator to inject Apollo 12 toward the Moon. The velocity will increase from 25,559 fps to 35,426 fps at TLI cutoff to return circumlunar trajectory from which midcourse corrections could be made with the SM RCS thrusters. Entry from a free-return trajectory would be at 6:52 a.m. EST Nov. 21 at 2.4 degrees north latitude by 92 west longitude after a flight time of 163 hrs 30 mins. A free-return trajectory from TLI would have an 1850 nm pericyynthion at the Moon.

### Transposition, Docking and Ejection (TD&E)

After the TLI burn, the Apollo 12 crew will separate the command/service module from the spacecraft lunar module adapter (SLA), thrust out away from the S-IVB, turn around and move back in for docking with the lunar module. Docking should take place at about three hours and 28 minutes GET. After the crew confirms all docking latches solidly engaged, they will connect the CSM-to-LM umbilicals and pressurize the LM with oxygen from the command module surge tank. At about 4:13 GET, the spacecraft will be ejected from the spacecraft LM adapter by spring devices at the four LM landing gear "knee" attach points. The ejection springs will impart about one fps velocity to the spacecraft. A 10 fps S-IVB attitude thruster evasive maneuver in plane at 4:25 GET will separate the spacecraft to a safe distance for the S-IVB "slingshot" maneuver. The "slingshot" is achieved by burning S-IVB auxiliary propulsion system subsequent to the dumping residual liquid oxygen through the J-2 engine bell to propel the stage into a trajectory passing the Moon's trailing edge and into solar orbit.

### Translunar Coast

Up to four midcourse correction burns are planned during the translunar coast phase, depending upon the accuracy of the trajectory resulting from the TLI maneuver. If required, the midcourse correction burns are planned at TLI+9 hours, TLI+31 hours, lunar orbit insertion (LOI) - 22 hours and LOI - 5 hours. The MCC-2 at TLI+31 hrs is a 64 fps SPS hybrid transfer maneuver which lowers pericynthion from 1852 nm to 60 nm and places Apollo 12 on a non free-return trajectory. Return to the free-return trajectory is always within the capability of the spacecraft service propulsion or descent propulsion systems.

During coast periods between midcourse corrections, the spacecraft will be in the passive thermal control (PTC) or "barbecue" mode in which the spacecraft will rotate slowly about its roll axis to stabilize spacecraft thermal response to the continuous solar exposure.

#### Lunar Orbit Insertion (LOI)

The first of two lunar orbit insertion burns will be made at 83:25 GET at an altitude of about 85 nm above the Moon. LOI-1 will have a nominal retrograde velocity change of 2890 fps and will insert Apollo 12 into a 60x169 nm elliptical lunar orbit. LOI-2 two orbits later at 87:44 GET will adjust the orbit to a 54x66-nm orbit, which because of perturbations of the lunar gravitational potential, should become circular at 60 nm at the time of rendezvous with the LM. The burn will be 169 fps retrograde. Both LOI maneuvers will be with the SPS engine near pericyynthion when the spacecraft is behind the Moon, out of contact with MSFN stations. After LOI-2 (circularization), the commander and lunar module pilot will enter the lunar module for a brief checkout and return to the command module.

#### Lunar Module Descent Lunar Landing

The lunar module will be manned and checked out for undocking and subsequent landing on the lunar surface at Apollo site 7. Undocking will take place at 107:58 GET prior to the MSFN acquisition of signal. A radially downward service module RCS burn of 2.5 fps will place the CSM on an equiperiod orbit with a maximum separation of 2.2 nm one half revolution after the separation maneuver. At this point, on lunar farside, the descent orbit insertion burn (DOI) will be made with the lunar module descent engine firing retrograde 72 fps at 109:23 GET. The burn will start at 10 percent throttle for 15 seconds and the remainder at 40 percent throttle.

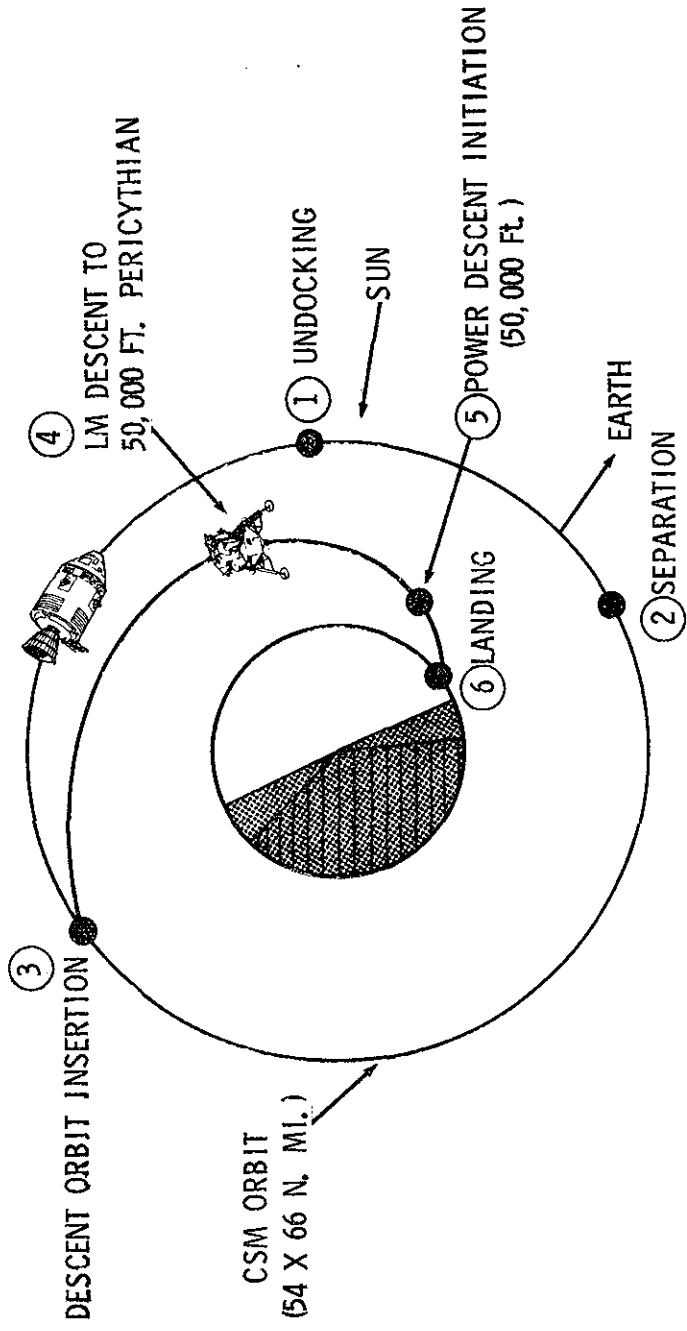

## LUNAR DESCENT EVENTS



The DOI maneuver lowers LM pericyynthion to 50,000 feet at a point about 15 degrees uprange of landing site 7.

A three-phase powered descent initiation (PDI) maneuver begins at pericyynthion at 110:20 GET using the LM descent engine to brake the vehicle out of the descent transfer orbit. The guidance-controlled PDI maneuver starts about 260 nm prior to touchdown, and is in retrograde attitude to reduce velocity to essentially zero at the time vertical descent begins. Spacecraft attitude will be windows up from powered descent to landing so that the LM landing radar data can be integrated continually by the LM guidance computer and better communications can be maintained. The braking phase ends at about 7,000 feet above the surface and the spacecraft is rotated to an upright windows-forward attitude. The start of the approach phase is called high gate, and the start of the landing phase at 500 feet is called low gate.

Both the approach phase and landing phase allow pilot takeover from guidance control as well as visual evaluation of the landing site. The final vertical descent to touchdown begins at about 100 feet when all forward velocity is nulled out. Vertical descent rate will be three fps. Present plans call for the crew to take over manual control at approximately 500 feet. Touchdown will take place at 110:31 GET.

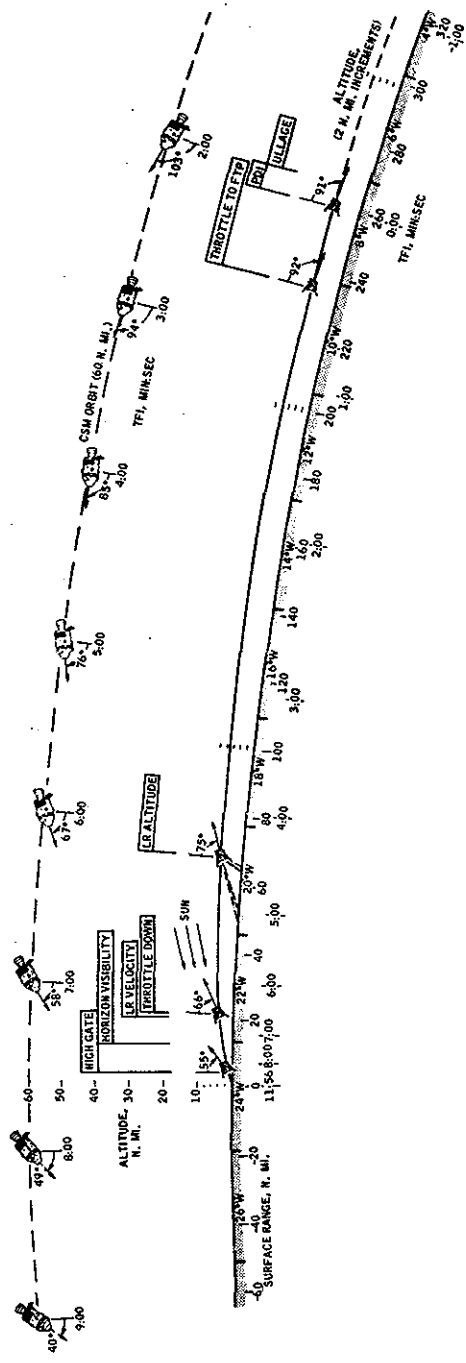

**POWERED DESCENT PROFILE**

Powered Descent Events

Summary

<u>Event</u>	<u>TFI MIN:SEC</u>	<u>Velocity FPS</u>	<u>Altitude Rate</u>	<u>Height Feet</u>
Powered Descent Initiation	0:00	5560	-4	49,235
Throttle to Maximum Thrust	0:26	5529	-3	49,158
Landing Radar Altitude Update	3:52	2959	-94	39,186
Throttle Recovery	6:24	1522	-106	24,592
Landing Radar Velocity Update	6:40	1301	-136	22,945
Horizon Visibility	7:04	1162	-148	20,130
High Gate	8:28	505	-137	7,335
Low Gate	10:22	35 (47)*	-14	524
Touchdown (Probe Contact)	11:56	-15 (0)*	-3	12

\* (Horizontal Velocity Relative to Surface)

-more-

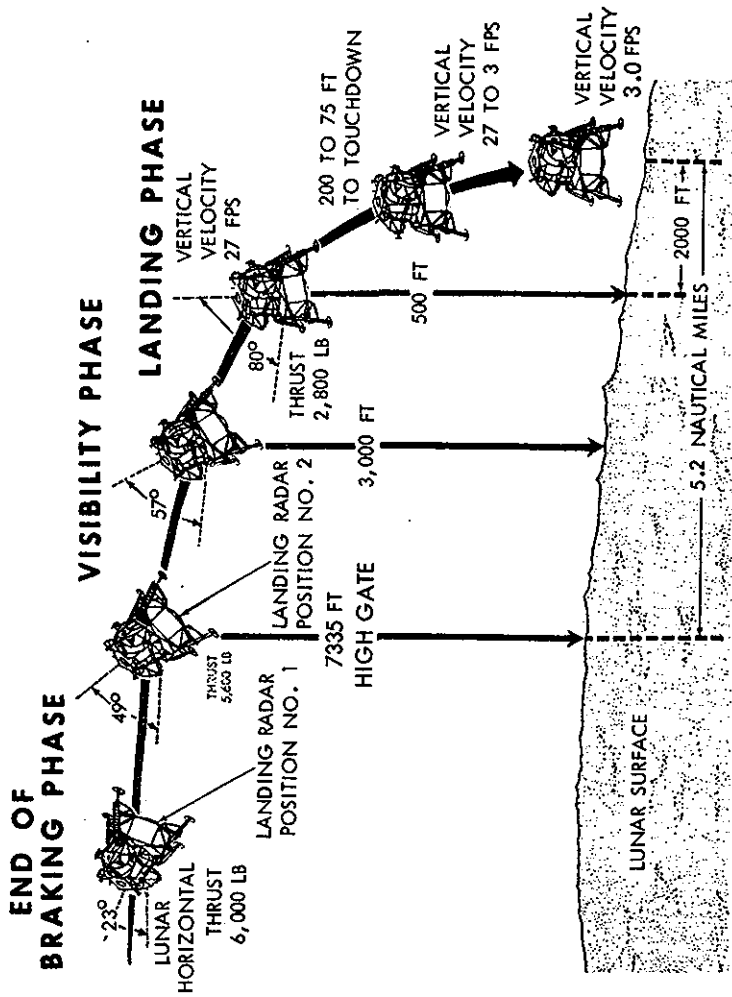

**NOMINAL DESCENT TRAJECTORY  
FROM HIGH GATE TO TOUCHDOWN**

## Lunar Surface Exploration

The manned lunar exploration begun by Apollo 11 will be broadened in the two periods of lunar surface extravehicular activity planned for Apollo 12. In addition to gathering more data on the lunar surface environment and bringing back geological samples from a second landing site, the Apollo 12 crew will deploy a series of experiments which will relay back to Earth long-term scientific measurements of the Moon's physical and environmental properties.

The experiment series, called the Apollo Lunar Surface Experiment Package (ALSEP 1), will remain on the surface to transmit scientific and engineering data to the Manned Space Flight Network for at least a year.

ALSEP 1 comprises equipment for the lunar passive seismic, lunar surface tri-axis magnetometer, solar wind spectrometer, and lunar ionosphere and atmosphere detectors. Additionally, three non-ALSEP experiments -- solar wind composition, field geology and Apollo lunar close-up camera photography -- will be deployed.

Experiments are aimed toward determining the structure and state of the lunar interior, the composition and structure of the lunar surface and the processes which modified the surface, and the evolutionary sequence leading to the Moon's present characteristics.

Apollo 12's stay on the lunar surface is planned not to exceed 31.5 hours, during which time Conrad and Bean will twice leave the LM to deploy the ALSEP, gather geologic samples and conduct experiments. The crew's operating radius will be limited by the range provided by the oxygen purge system (OPS) mounted atop each man's portable life support system (PLSS) backpack. The OPS supplies one-half hour of emergency breathing oxygen and suit pressure.

Among the tasks assigned Conrad and Bean for the two EVA periods are:

- \*Collecting a contingency sample near the LM of about two pounds of lunar material.

- \*Evaluating crew ability to perform useful work in the lunar environment, such as lifting and maneuvering large packages, unstowing and erecting the S-Band antenna. Also, the crew will assess their ability to move about on the lunar terrain and their ability to meet timelines.

\*Inspecting the LM exterior for effects of landing impact and lunar surface erosion from descent engine plume.

\*Gathering about 30 to 60 pounds of representative lunar surface material, including a core sample, individual rock samples and fine-grained fragments. The crew will photograph thoroughly the areas from which samples are taken.

\*Making observations and gathering data on the mechanical properties and terrain characteristics of the lunar surface and conducting other lunar field geological surveys.

An added bonus of Apollo 12's EVA may be the retrieval of portions of the Surveyor III spacecraft which have been exposed to the lunar environment since the spacecraft soft-landed April 20, 1967 at 3.3° south latitude by 23 west longitude. The Surveyor rests approximately 150 feet down a 14 degree slope of a crater that is 50 feet deep and about 650 feet wide.

Surveyor III's television camera sent back 6,315 pictures of the terrain features in the crater in which the spacecraft landed. The 17-pound TV camera, with its variety of electronic and mechanical components, will be one of the major items Conrad and Bean hope to retrieve. A modified pair of bolt-cutters and a stowage bag will be carried for removing and retrieving Surveyor components.

Before Conrad and Bean begin snipping off portions of the Surveyor spacecraft, they will take color photographs of areas covered by the Surveyor TV camera to show the comparative change, in any, of the surface features.

The trek to the Surveyor landing site will depend upon the accuracy of the Apollo 12 lunar module landing. If the LM lands within one kilometer (3,300 feet) of Surveyor, the landing crew will make a traverse to Surveyor during the second EVA period.

## Ascent, Lunar Orbit Rendezvous

Following the 31.5 hour lunar stay the LM ascent stage will lift off the lunar surface to begin the rendezvous sequence with the orbiting CSM. Ignition of the LM ascent engine will be at 142:01 for a 7 min 11 sec burn with a total velocity of 5535 fps. Powered ascent is in two phases: vertical ascent for terrain clearance and the orbital insertion phase. Pitchover along the desired launch azimuth begins as the vertical ascent rate reaches 50 fps about 10 seconds after liftoff at about 272 feet in altitude. Insertion into a 9 x 45-nm lunar orbit will take place about 166 nm west of the landing site.

Following LM insertion into lunar orbit, the LM crew will compute onboard the major maneuvers for rendezvous with the CSM which is about 260 nm ahead of the LM at this point. All maneuvers in the sequence will be made with the LM RCS thrusters. The premission rendezvous sequence maneuvers, times and velocities which likely will differ slightly in real time, are as follows:

Concentric sequence initiate (CSI): At first LM apolune after insertion, 142:58 GET, 50 fps prograde, following some 20 minutes of LM rendezvous radar tracking and CSM sextant/VHF ranging navigation. CSI will be targeted to place the LM in an orbit 15 nm below the CSM at the time of the later constant delta height (CDH) maneuver.

The CSI burn may also initiate corrections for any out-of-plane dispersions resulting from insertion azimuth errors. Resulting LM orbit after CSI will be 46.7x44.5 nm and will have a catchup rate to the CSM of .07 degrees per minute.

Another plane correction is possible about 30 minutes after CSI at the nodal crossing of the CSM and LM orbits to place both vehicles at a common node at the time of the CDH maneuver at 143:56 GET.

Terminal phase initiation (TPI): This maneuver occurs at 144:36 and adds 24 fps along the line of sight toward the CSM when the elevation angle to the CSM reaches 26.6 degrees. The LM orbit becomes 61.9x43.8 nm and the catchup rate to the CSM decreases to .033 degrees per second, or a closing rate of 133 fps.

Midcourse correction maneuvers will be made if needed, followed by four braking maneuvers. Docking nominally will take place at 145:40 GET to end three and one-half hours of the rendezvous sequence.

The LM ascent stage will be jettisoned at 147:21 GET and CSM RCS 1.5 fps maneuver will provide separation.

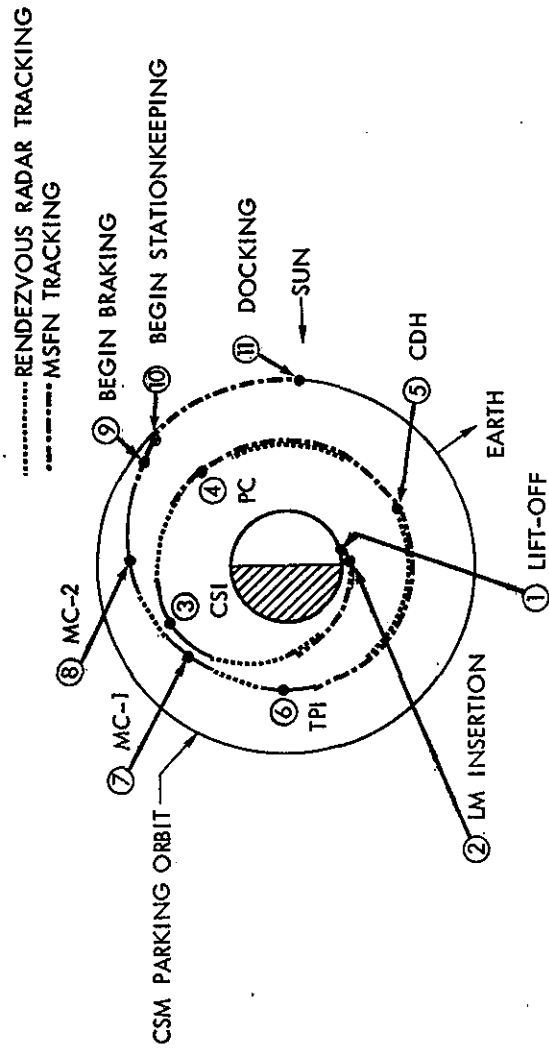

## ASCENT THROUGH DOCKING



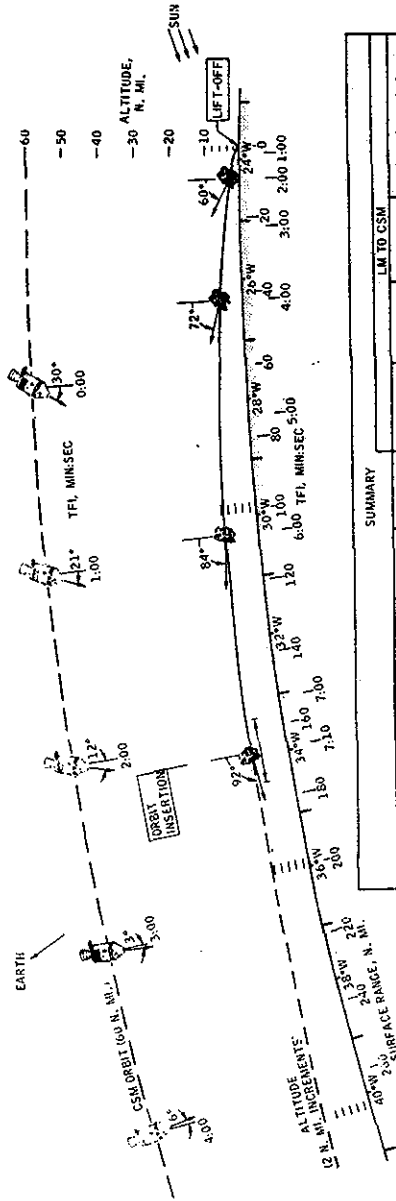

EVENT	TFL MIN:SEC	INERTIAL VELOCITY, FPS	ALTITUDE RATE, FPS	ALTITUDE FT.	LM TO CSX			
					RANGE, N. MI.	RANGE RATE, FPS	PHASE ANGLE, DEG	
LIFT-OFF	0:00	15	0	0	82	3571	3.3	45.1
END OF VERTICAL RISE	0:10	56	55	272	88	3793	3.8	49.4
	2:00	1036	172	14 316	160	3807	8.9	73.6
	4:00	2474	185	36 764	224	2549	12.9	82.8
	6:00	4273	106	55 024	258	797	14.97	86.3
ORBIT INSERTION	7:10.6	5535.5	32.2	59 983.2	260.2	-454.9	15.1	86.7

$V_0 = 54 959.7 \text{ FT}$   
 $R_0 = 45.3 \text{ N. MI.}$   
 $\gamma = 17.4^\circ$   
 $\gamma = .33^\circ$   
 $AV = 6049 \text{ FPS}$

## ORBIT INSERTION PHASE

### Ascent Stage Deorbit

Prior to transferring to the command module, the LM crew will set up the LM guidance system to maintain the ascent stage in an inertial attitude. At about 149:28 GET the LM ascent engine will ignite on ground command for 200 fps retrograde burn targeted for ascent stage impact at 149:56 about five nm south of Site 7. The burn will have a small out-of-plane north component to drive the stage back toward the ground track of the original landing site. The ascent stage will impact at about 5500 fps at an angle of four degrees relative to the local horizontal. Impacting an object with a known velocity and mass near the landing site will provide experimenters with an event for calibrating readouts from the ALSEP seismometer left behind at Site 7. The ascent stage deorbit also serves to remove debris from lunar orbit.

A plane change maneuver at 159:02 GET will place the CSM on an orbital track passing directly over the craters Descartes and Fra Mauro two revolutions later. The maneuver will be a 360-fps SPS burn out of plane for a plane change of 3.2 degrees.

The Apollo 12 crew will obtain extensive photographic coverage of these lunar surface features.

### Transearth Injection (TEI)

The nominal transearth injection burn will be at 172:21 GET following 89 hours in lunar orbit. TEI will take place on the lunar farside, will be a 3113 fps posigrade SPS burn of 2 min 17 sec duration and will produce an entry velocity of 36,129 fps after a 72 hr transearth flight time.

### Transearth Coast

Three corridor-control transearth midcourse correction burns will be made if needed: MCC-5 at TEI+15 hrs, MCC-6 at entry interface (EI) -22 hrs and MCC-7 at EI -3 hrs.

### Entry, Landing

Apollo 12 will encounter the Earth's atmosphere (400,000 feet) at 244:26 GET at a velocity of 36,129 fps and will land approximately 1250 nm downrange from the entry-interface point using the spacecraft's lifting characteristics to reach the landing point. Splashdown will be at 244:35 at 16 degrees south latitude by 165 degrees west longitude.

### Recovery Operations

The prime recovery line for Apollo 12 is the mid-Pacific along the 175th west longitude above 15 degrees north latitude, and jogging to 165 degrees west longitude below the equator. The aircraft carrier USS Hornet, Apollo 12 prime recovery ship, will be stationed near the end-of-mission aiming point prior to entry.

Splashdown for a full-duration lunar landing mission launched on time November 14 will be at 16 degrees south by 165 degrees west.

Launch abort landing areas extend downrange 3,400 nautical miles from Kennedy Space Center, fanwise 50 nm above and below the limits of the variable launch azimuth (72-96 degrees). Ships on station in the launch abort area will be the destroyer USS Hawkins, and the insertion tracking ship USNS Vanguard. The landing platform helicopter, USS Austin will be stationed further south in the Atlantic to support the possible aborts during translunar coast.

In addition to the primary recovery ship located on the mid-Pacific recovery line and surface vessels on the Atlantic Ocean recovery line (along 30th west meridian north) and in the launch abort, thirteen HC-130 aircraft will be on standby at eight staging bases around the Earth: Guam; Hawaii; American Samoa; Bermuda; Lajes, Azores; Ascension Island; Mauritius and the Panama Canal Zone.

Apollo 12 recovery operations will be directed from the Recovery Operations Control Room in the Mission Control Center, supported by the Atlantic Recovery Control Center, Norfolk, Va. and the Pacific Recovery Control Center, Kunia, Hawaii.

After splashdown, the Apollo 12 crew will don biological isolation garments passed to them through the spacecraft hatch by a recovery swimmer. The crew will be carried by helicopter to Hornet where they will enter a Mobile Quarantine Facility (MQF) about 90 minutes after landing.

## APOLLO 12 ONBOARD TELEVISION

Two color television cameras are planned to be carried aboard Apollo 12 -- one in the command module and one in the lunar module descent stage to transmit a real-time picture of the two periods of lunar surface extravehicular activity. A black and white TV camera may be substituted for the LM color camera.

Both cameras have been refurbished and modified from previous missions; the Apollo 10 command module camera will be stowed in the LM for lunar surface TV, and the Apollo 11 command module camera will be used in the Apollo 12 command module.

The color TV cameras weigh 12 pounds and are fitted with zoom lens for wideangle or closeup fields of view. The command module camera is fitted with a three-inch monitor which can be detached and placed at a convenient location in the CM. The LM camera will be aimed and focused by the LM crew during EVA with the help of Mission Control.

Built by Westinghouse Electric Corp. Aerospace Division, Baltimore Md., the color cameras output a standard 525-line, 30 frame-per-second signal in color by use of rotating color wheels. The black and white signals carried on the S-Band downlink will be converted to color at the Mission Control Center.

Modifications to the LM color camera include painting it white for thermal control, substituting coated metal gears for plastic gears in the color wheel drive mechanism, provision for internal heat conduction paths to the camera outer shell for radiation, and use of a special bearing lubricant.

The lunar module black and white television camera weighs 7.25 pounds and draws 6.5 watts of 24-32 volts DC power. Scan rate is 10 frames-per-second at 320 lines-per-frame. The camera body is 10.6 inches long, 6.5 inches wide and 3.4 inches deep. The bayonet lens mount permits lens changes by a crewman in a pressurized suit. Two lenses, a wideangle lens for close-ups and large areas, and a lunar day lens for viewing lunar surface features and activities in the near field of view with sunlight illumination, will be provided for the lunar TV camera.

APOLLO 12 TV SCHEDULE

DAY	DATE	EST	GET	COVERAGE	DURATION
FRIDAY	NOV. 14	14:42	03:25	TRANSPOSITION/DOCKING	1 + 05
SATURDAY	NOV. 15	17:47	30:25	HYBRID TRAJ./SPACECRAFT INTERIOR	0 + 35
MONDAY	NOV. 17	02:52	63:30	EARTH, IVT, S/C INTERIOR	0 + 50
		20:52	81:30	PRE LOI-1, LUNAR SURFACE	0 + 20
		23:22	84:00	LUNAR SURFACE	0 + 30
TUESDAY	NOV. 18	23:12	107:50	UNDOCKING/FORMATION FLYING	0 + 20
WEDNESDAY	NOV. 19	06:02	114:40	LUNAR SURFACE EVA	3 + 30
THURSDAY	NOV. 20	00:42	133:20	EVA - 2, EQUIPMENT JETTISON	4 + 55
		12:37	145:15	DOCKING	0 + 30
FRIDAY	NOV. 21	16:17	*172:55	POST - TEI/LUNAR SURFACE	0 + 20
SUNDAY	NOV. 23	06:52	223:15	MOON - EARTH - S/C INTERIOR	0 + 30

\* Plans call for this TV event to be recorded for later playback.

# APOLLO 12 TELEVISION DEPLOYMENT

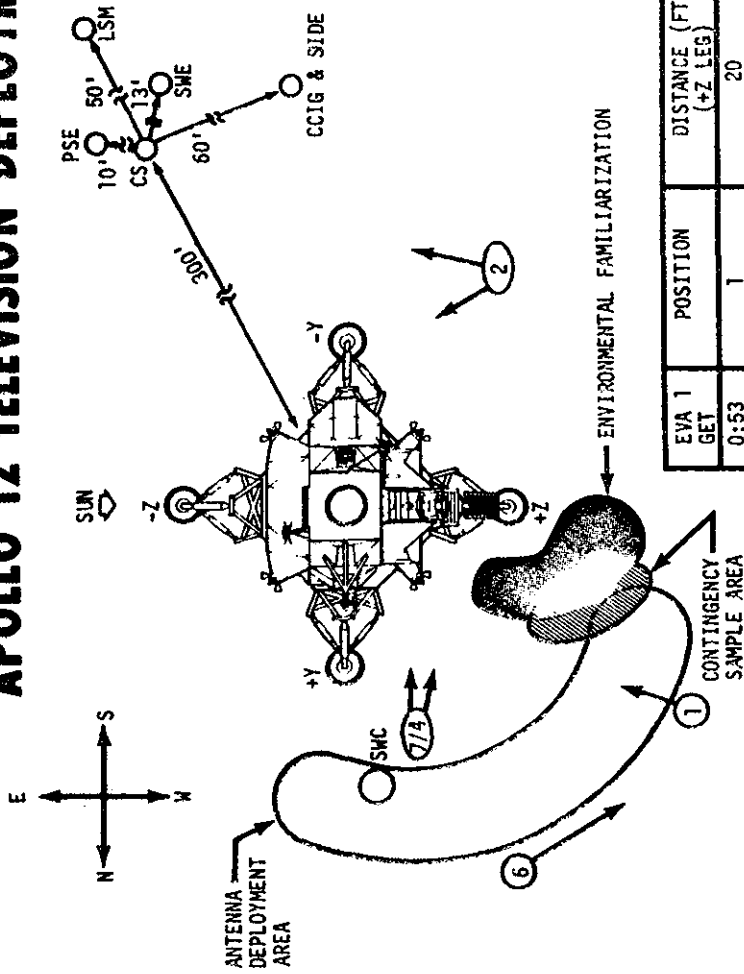

EVA 1 GET	POSITION	DISTANCE (FT) (+Z LEG)	PURPOSE
0:53	1	20	PAN/MESA OBS
1:08	2	20	SEQ BAY OPNS
~1:39	3		ALSEP AREA
~2:36	4	10'	MESA AREA
			INGRESS
EVA 2			
0:30	~6	~30	GEOL TRAVERSE
2:45	7	20	TRNSFR/ING/JETT.

## APOLLO 12 SCIENTIFIC EXPERIMENTS

The Moon's surface is bombarded by the solar wind which consists of charged particles, mostly protons and electrons, emanating from the Sun. There also exists an interplanetary magnetic field which is carried from the Sun by the solar wind.

The Earth has its own magnetic field which protects it from the direct stream of solar wind charged particles and the solar magnetic flux. The Moon, however, has only a small or negligible magnetic field of its own. As a result the Moon is subject to forces of the solar wind, the solar magnetic field and, during certain times, to the Earth's magnetic field.

Several experiments in the Apollo Lunar Surface Experiments Package (ALSEP) will measure these influences both in sunlight and in darkness on the Moon and, as the Moon passes through the region of the Earth's magnetic field (magnetosphere). Other experiments will obtain information on the physical properties of the Moon's surface and its interior.

### The Lunar Surface Magnetometer (LSM)

The scientific objective of the magnetometer experiment is to measure the magnetic field at the lunar surface. Charged particles and the magnetic field of the solar wind impact directly on the lunar surface. Some of the solar wind particles are absorbed by the surface layer of the Moon. Others may be deflected around the Moon. The electrical properties of the material making up the Moon determine what happens to the magnetic field when it hits the Moon. If the Moon is a perfect insulator the magnetic field will pass through the Moon undisturbed. If there is material present which acts as a conductor, electric currents will flow in the Moon.

Two possible models are shown in the next drawing. The electric current carried by the solar wind goes through the Moon and "closes" in the space surrounding the Moon, (figure a). This current (E) generates a magnetic field (M) as shown. The magnetic field carried in the solar wind will set up a system of electric currents in the Moon or along the surface. These currents will generate another magnetic field which tries to counteract the solar wind field, (figure b). This results in a change in the total magnetic field measured at the lunar surface.

# LUNAR ENVIRONMENT

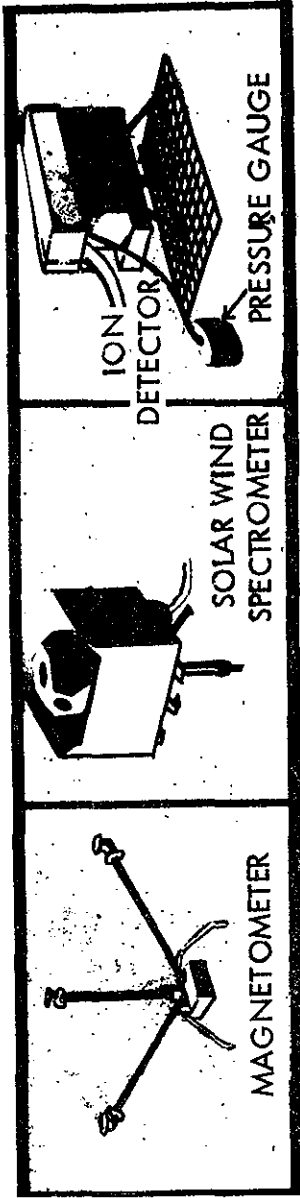

## MOON - SOLAR WIND INTERACTION

-more-

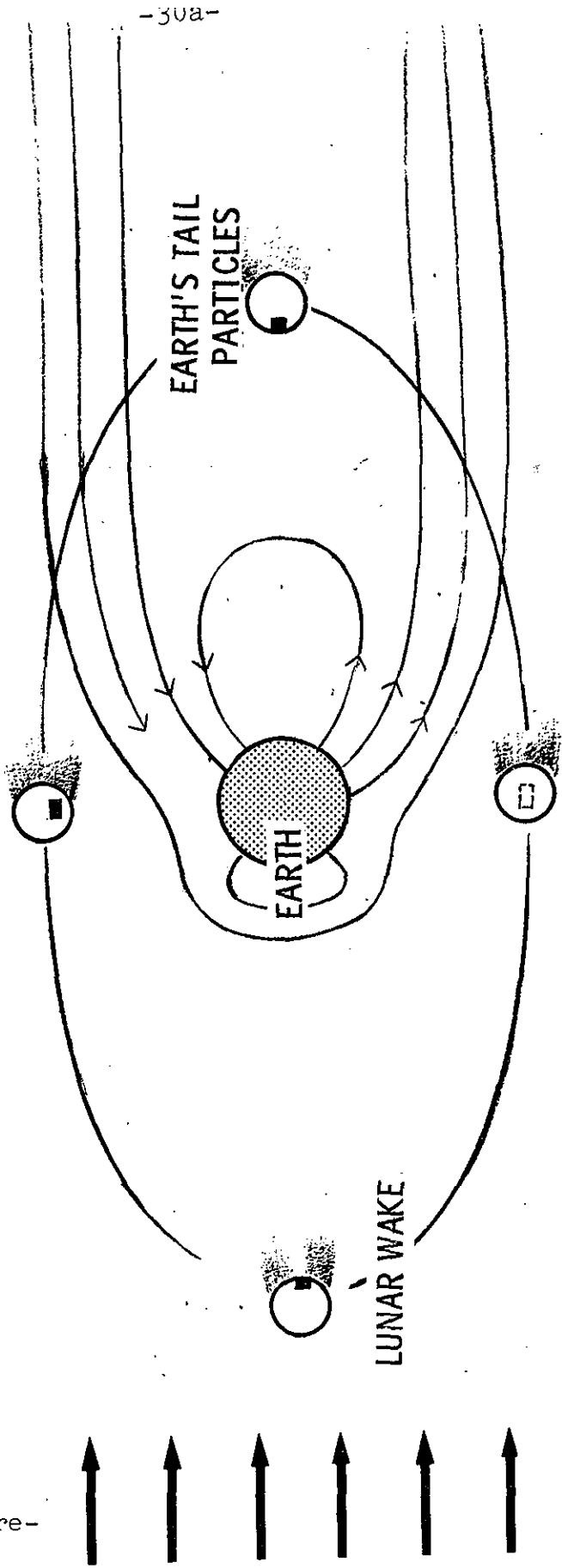



MAGNETIC FIELD OF MOON  
 (M) GENERATED BY THE ELECTRIC  
 FIELD  $\vec{E}$  CARRIED IN THE SOLAR WIND

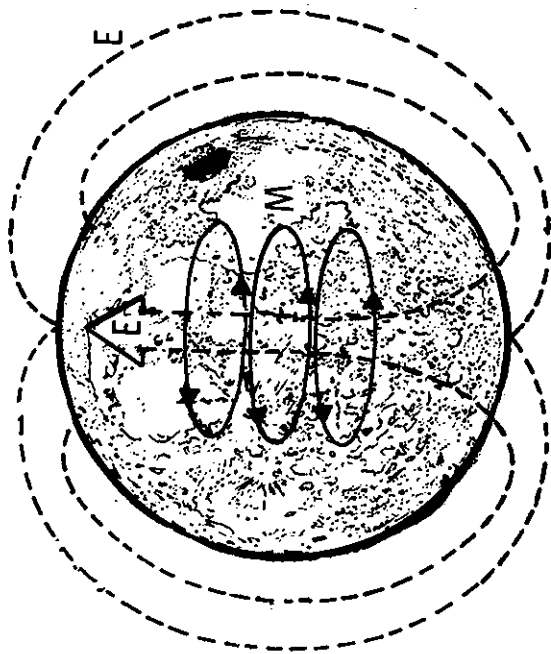

(a)

MAGNETIC FLUX CARRIED IN  
 THE SOLAR WIND INDUCES  
 EDDY CURRENTS  $\vec{E}$  WHICH  
 IN TURN INDUCES A MAGNETIC  
 FIELD

-30b-

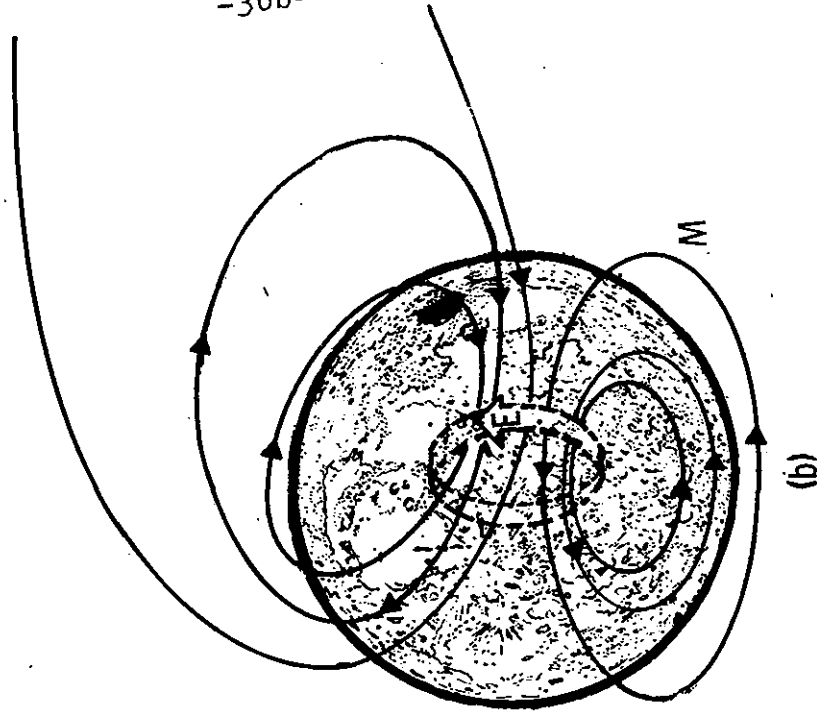

(b)

The magnitude of this difference can be determined by independently measuring the magnetic field in the undisturbed solar wind nearby, yet away from the Moon's surface. It is planned to obtain this data from Explorer 35, the unmanned spacecraft now in lunar orbit. The value of the magnetic field change at the Moon's surface can then be used to deduce information on the electrical properties of the Moon. This, in turn, can be used to better understand the internal temperature of the Moon and contribute to better understanding of the origin and history of the Moon.

The design of the tri-axis flux-gate magnetometer and analysis of experiment data are the responsibility of Dr. Charles P. Sonett - NASA/Ames Research Center; Dr. Jerry Modisette - NASA/Manned Spacecraft Center; and Dr. Palmer Dyal - NASA/Ames Research Center.

The magnetometer consists of three magnetic sensors aligned in three orthogonal sensing axes, each located at the end of a fiberglass support arm extending from a central structure. This structure houses both the experiment electronics and the electro-mechanical gimbal/flip unit which allows the sensor to be pointed in any direction for site survey and calibration modes. The astronaut aligns the magnetometer experiment to within  $+3^\circ$  East-West using a shadwograph on the central structure, and to within  $+3^\circ$  of the vertical using a bubble level mounted on the Y sensor boom arm.

Size, weight and power are as follows:

Size (inches) deployed	40 high with 60 between sensor heads
Weight (pounds)	17.5
Peak Power Requirements (watts)	
Site Survey Mode	11.5
Scientific Mode	6.2
	12.3 (night)
Calibration Mode	10.8

The magnetometer experiment operates in three modes:

Site Survey Mode - An initial site survey is performed in each of the three sensing modes for the purpose of locating and identifying any magnetic influences permanently inherent in the deployment site so that they will not affect the interpretation of the ME sensing of magnetic flux at the lunar surface. Although no measurable lunar magnetic field has been detected to date, the possibility of localized magnetism remains; thus this precaution must be taken.

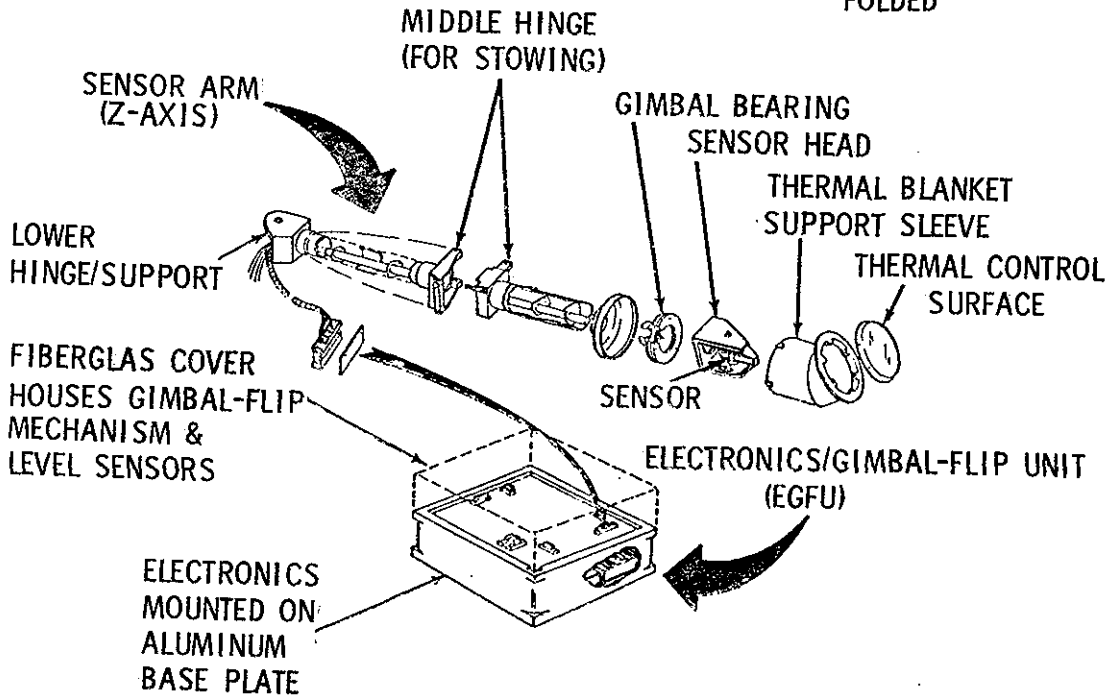
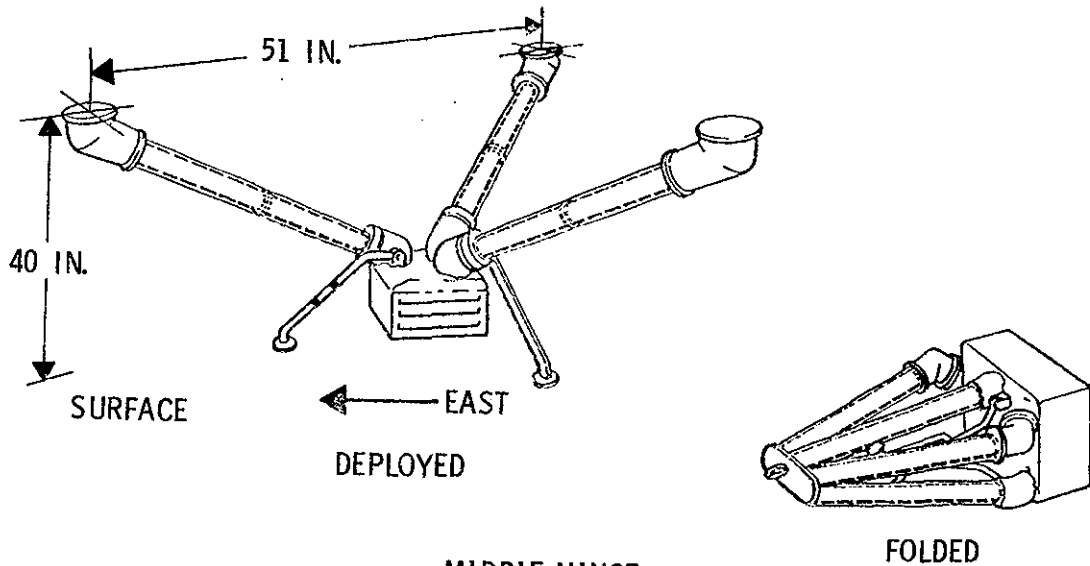

## LUNAR SURFACE MAGNETOMETER

Scientific Mode - This is the normal operating mode wherein the strength and direction of the lunar magnetic field are measured continuously. The three magnetic sensors provide signal outputs proportional to the incidence of magnetic field components parallel to their respective axes. Each sensor will record the intensity three times per second which is faster than the magnetic field is expected to change. All sensors have the capability to sense over any one of three dynamic ranges with a resolution of 0.2 gamma.\*

-100 to +100 gamma

-200 to +200 gamma

-400 to +400 gamma

\*Gamma is a unit of intensity of a magnetic field. The Earth at the equator, for example, is 35,000 gamma. The interplanetary magnetic field from the Sun has been recorded at 5 to 10 gamma.

Calibration Mode - This is performed automatically at 12-hour intervals to determine the absolute accuracy of the magnetometer sensors and to correct any drift from their laboratory calibration.

#### Lunar Ionosphere Detector (LID)

The scientific objective of the Lunar Ionosphere Detector is to study the charged particles in the lunar atmosphere. In conjunction with the Lunar Atmosphere Detector both charged and neutral particles will be measured by Apollo 12 ALSEP. Although the amount of material detected is expected to be very small, knowledge of the lunar ionosphere density and composition will contribute to the understanding of the Moon's chemistry, radioactivity, and volcanic activity and to the chemical composition of the solar wind. Elements of the solar wind are expected to be the major ionosphere component, but observation from Earth of lunar "hot spots" suggest gas is being released from the Moon. The impact of meteorites on the lunar surface will vaporize both the meteorite and lunar surface material. While all these factors contribute material to the lunar ionosphere and atmosphere, forces are at work contributing to their escape, i.e., the low gravity of the Moon, the high thermal activity and the sweeping solar wind which can remove as well as contribute particles.

The Lunar Ionosphere Detector will help identify the ionized charged elements and molecules. It will also measure the charged particles as the Moon passes through the Earth's magnetic field. The experiment is also designed to give us a preliminary value for the electric field of the lunar surface.

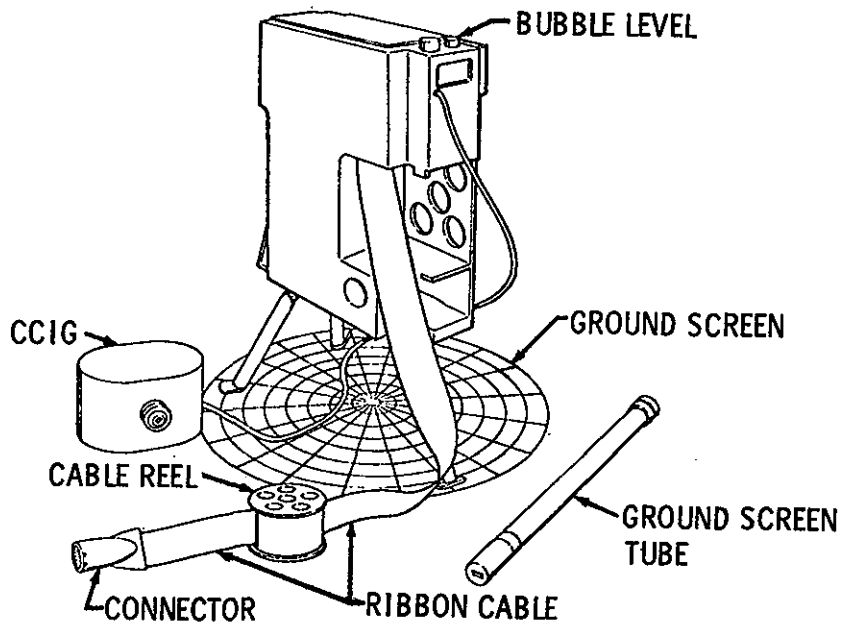
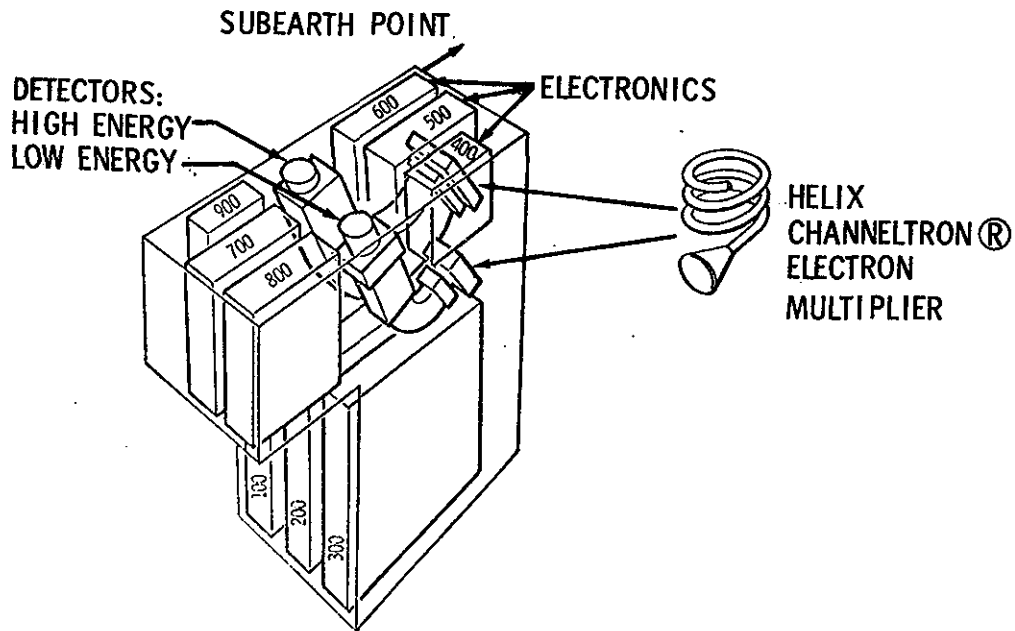

## ION DETECTOR INSTRUMENT

The ALSEP Lunar Ionosphere Detector design and subsequent data analysis are the responsibilities of Dr. John Freeman and Dr. Curt Michel both of Rice University.

The LID utilizes a suprathermal ion detector to detect and count positive ions. It contains two curved plate analyzers that measure the energy of positive ions. One curved plate analyzer measures ions with an energy range from 0.2 electron volts to 48.6 (e.v.). It contains a velocity filter (crossed magnetic and electric fields) that admits ions with velocities from  $4 \times 10^4$  to  $9.35 \times 10^6$  cm/sec. From the velocity data, the mass of the solar wind particles in the energy range from 10 e.v. to 3500 e.v. can be determined. The mass of these high energy particles from solar flares cannot be determined because the analyzer does not have the velocity selector.

The weight of the instrument is 19.6 pounds, operational power is 60 watts, and input voltage is +29 VDC.

#### Lunar Atmosphere Detector (LAD)

The scientific objective of the Lunar Atmosphere Detector is to measure the density, temperature, and the changes in the lunar atmosphere. The LAD basically measures the total pressure of neutral (inactive) particles whereas the Ionosphere Detector measures composition of the ionized (active) particles. The densities are expected to build up on the sunlit side and to fall off on the dark side of the Moon. These measurements are expected to contribute to understanding of the processes which shape the lunar surface. The erosional features, recognized from the Apollo 11 soil samples, are produced by forces which are not similar to processes known on Earth.

The design of the experiment and the subsequent data analysis are the responsibility of Dr. Francis Johnson, Southwest Center for Advanced Studies and Mr. Dallas Evans, NASA Manned Spacecraft Center.

The lunar atmosphere detector consists of a cold cathode ion gauge assembly, electronics package, and structural and thermal housings. The neutral particles are ionized and collected by the cathode, which is one of a pair of sensor electrodes, and produce a current at the input circuitry of the electronics proportional to the particle density. This signal is amplified and processed by the electronics for transmission through the central station back to Earth. The gauge temperature is measured directly and is inserted into the data handling circuitry.

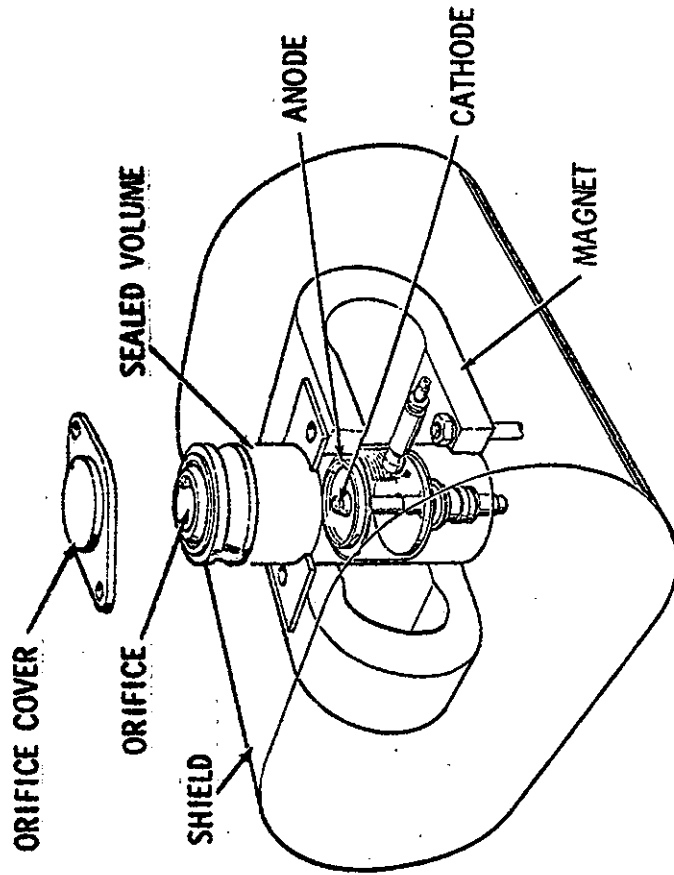

## LUNAR ATMOSPHERIC DETECTOR

(COLD CATHODE ION GAUGE INSTRUMENT)

Any one of seven different dynamic ranges may be selected, permitting detection of neutral atom densities ranging from  $10^{-8}$  torr to  $10^{-12}$  torr. The desired sensitivity may be chosen by command from Earth or by internal adjustments.

This experiment will give the particle density and temperature of the ambient lunar atmosphere, including any temporal variations either of a random character or associated with lunar local time or solar activity.

Instrument parameters are as follows:

Gauge accuracy	$\pm 30\%$ above $10^{-10}$ torr
Weight	$\pm 50\%$ below $10^{-10}$ torr
Operating Power	2 watts

#### The Solar Wind Spectrometer

The Solar Wind Spectrometer will measure the strength, velocity and directions of the electrons and protons which emanate from the Sun and reach the lunar surface. The solar wind is the major external force working on the Moon's surface. The spectrometer measurements will help interpret the magnetic field of the Moon, the lunar atmosphere and the analysis of lunar samples.

Knowledge of the solar wind will help us understand the origin of the Sun and the physical processes at work on the Sun, i.e., the creation and acceleration of these particles and how they propagate through interplanetary space. It has been calculated that the solar wind puts one kiloton of energy into the Earth's magnetic field every second. This enormous amount of energy influences such Earth's processes as the aurora, ionosphere and weather. Although it requires twenty minutes for a kiloton to strike the Moon its effects should be apparent in many ways.

In addition to the Solar Wind Spectrometer, an independent experiment (the Solar Wind Composition Experiment) will collect the gases of the solar wind for return to Earth for analysis.

The design of the spectrometer and the subsequent data analysis are the responsibility of Dr. Conway Snyder, Dr. Douglas Clay and Dr. Marcia Neugebauer of the Jet Propulsion Laboratory.



Seven identical modified Faraday cups (an instrument that traps ionized particles) are used to detect and collect solar wind electrons and protons. One cup is to the vertical, whereas the remaining six cups surround the vertical where the angle between the normals of any two adjacent cups is approximately 60 degrees. Each cup measures the current produced by the charged particle flux entering into it. Since the cups are identical, and if the particle flux is equal in each direction, equal current will be produced in each cup. If the flux is not equal in each direction, analysis of the amount of current in the seven cups will determine the variation of particle flow with direction. Also, by successively changing the voltages on the grid of the cup and measuring the corresponding current, complete energy spectra of both electrons and protons in the solar wind are produced.

Data from each cup is processed in the ALSEP data subsystem. The measurement cycle is organized into 16 sequences of 186 ten-bit words. The instrument weighs 12.5 pounds, has an input voltage of about 28.5 volts and has an average input power of about 3.2 watts. The measurement ranges are as follows:

Electrons

High gain modulation	10.5 - 1376 e.v. (electron volts)
Low gain modulation	6.2 - 817 e.v.

Protons

High gain modulation	75 - 9600 e.v.
Low gain modulation	45 - 5700 e.v.

Field of View 6.0 Steradians

Angular Resolution 15° (approximately)

Minimum Flux Detectable  $10^6$  particles/cm<sup>2</sup>/sec

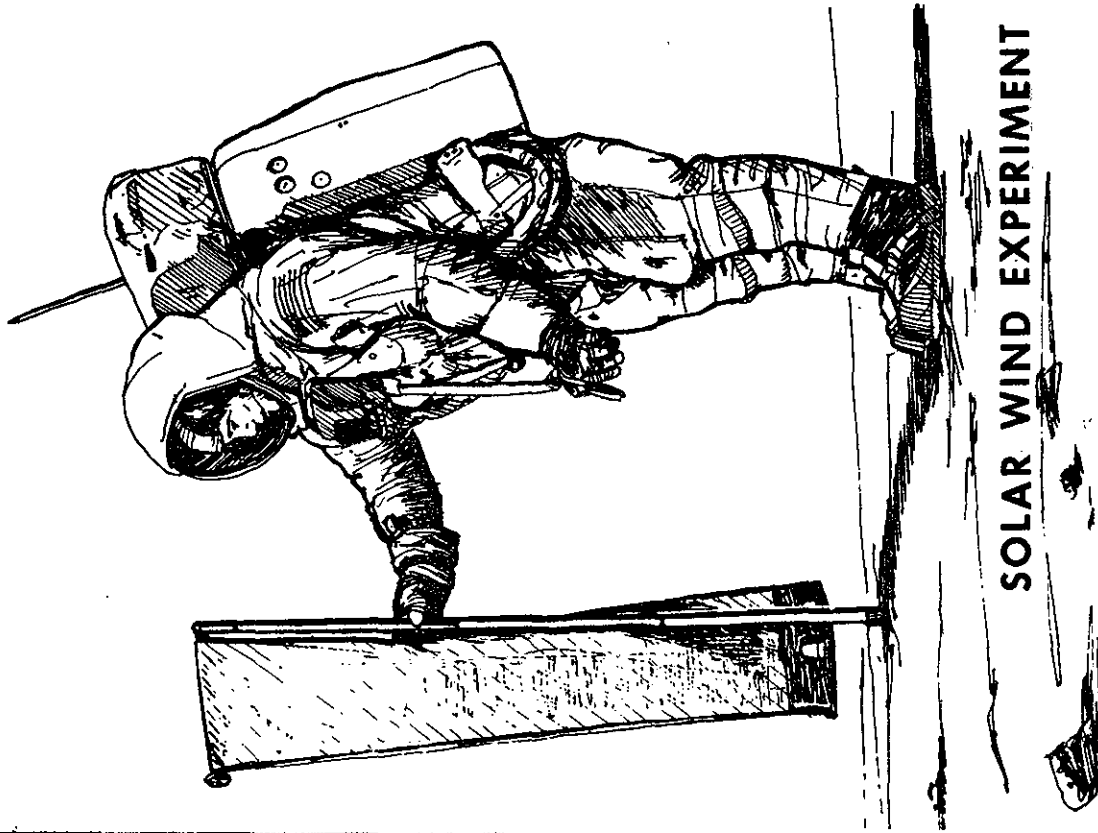

**SOLAR WIND EXPERIMENT**

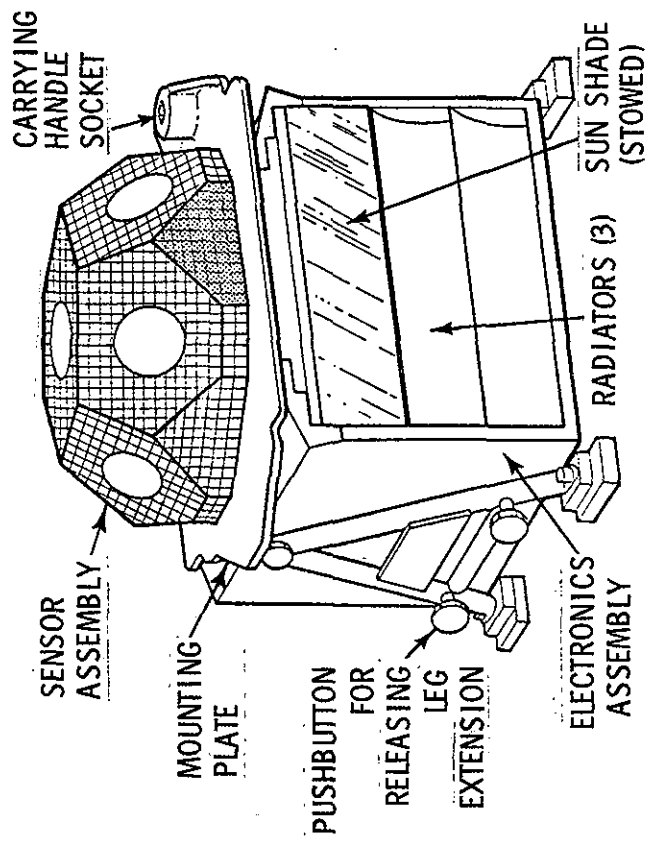

**SOLAR WIND SPECTROMETER**

Solar Wind Composition Experiment (SWCE)

The scientific objective of the solar wind composition experiment is to determine the elemental and isotopic composition of the noble gasses in the solar wind. (This is not an ALSEP experiment.)

The solar wind composition detector experiment design and subsequent data analysis are the responsibility of: J. Geiss and P. Eberhardt, University of Bern (Switzerland); P. Signer, Swiss Federal Institute of Technology; with Professor Geiss assuming the responsibility of Principal Investigator.

As in Apollo 11, the SWC detector will be deployed on the Moon and brought back to Earth by the astronauts. The detector, however, will be exposed to the solar wind flux for seventeen hours instead of two hours as in Apollo 11. Also, in the Apollo 11 mission the detector was found to be too close to the working areas of the astronauts. In Apollo 12, the detector will be placed a sufficient distance away from the LM so that it will be free of lunar dust kicked up by astronaut activity.

The solar wind composition detector consists of an aluminum foil 4 ft<sup>2</sup> area and about 0.5 mils thick rimmed by Teflon for resistance to tear during deployment. A staff and yard arrangement will be used to deploy the foil and to maintain the foil approximately perpendicular to the solar wind flux. Solar wind particles will penetrate into the foil, allowing cosmic rays to pass right through. The particles will get firmly trapped at a depth of several hundred atomic layers. After exposure on the lunar surface, the foil is reeled and returned to Earth.

## Field Geology Investigations

The scientific objectives of the Apollo Field Geology Investigations are to determine the composition of the Moon and the processes which shape its surfaces. This information will help to determine the history of the Moon and its relationship to the Earth. The early investigations to understanding the nature and origin of the Mare are limited by mission constraints. Apollo 11 visited the Sea of Tranquility (Mare Tranquillitatis), Apollo 12 will study the Ocean of Storms (Oceanus Procellarum). The results of these studies should help establish the nature of Mare-type areas.

Geology investigations of the Moon actually began with the telescope. Systematic geology mapping began ten years ago with a team of scientists at the U.S. Geological Survey. Ranger, Surveyor and especially Lunar Orbiter data enormously increased the detail and accuracy of these studies. The Apollo 11 investigations represent another enormous advancement in providing new evidence on the Moon's great age, its curious chemistry, the surprisingly high density of the lunar surface material.

On Apollo 12, almost the entire second EVA will be devoted to the Field Geology Investigations and the collection of documented samples. The sample locations will be photographed before and after sampling. The astronauts will carefully describe the setting from which the sample is collected. Samples will be taken along the rays of large craters. It is this material, ejected from great depth, which will provide evidence on the nature of the lunar interior. In addition to specific tasks, the astronauts will be free to photograph and sample phenomena which they judge to be unusual, significant, and interesting. The astronauts are provided with a package of detailed photo maps which they will use for planning traverses. Photographs will be taken from the LM window. Each feature or family of features will be described, relating to features on the photo maps. Areas and features where photographs should be taken and representative samples collected will be marked on the maps as determined primarily by the astronauts but with inputs from Earth-based geologists.

The Earth-based geologists will be available to advise the astronauts in real-time and will work with the data returned, the photos, the samples of rock and the astronauts' observations to reconstruct here on Earth the astronauts' traverse on the Moon.

If landing accuracy permits, the Apollo 12 astronauts plan to visit the Surveyor III spacecraft. Analytical results of lunar samples collected from the Surveyor III site will be compared to chemical analysis made by the Surveyor alpha particle back-scatter experiment.

The Field Geological Investigations are the responsibility of Dr. Eugene Shoemaker, Principal Investigator, California Institute of Technology. His Co-Investigators are Aaron Waters, University of California (Santa Cruz); E. M. Goddard, University of Michigan; H. H. Schmitt, Astronaut; T. H. Foss, NASA; J. J. Rennilson, Jet Propulsion Laboratory; Gordon Swann, USGS; M. H. Hait, USGS; E. H. Holt, USGS; and R. M. Batson, USGS.

Each astronaut will carry a Lunar Surface Camera (a modified 70 mm electric Hasselblad). The camera has a 60 mm Biogon lens, with apertures ranging from f/5.6 to f/45. Its focus range is from 3 ft to infinity, with detents at the 5 foot, 15 foot and 74 foot settings. The camera system incorporates a rigidly installed glass plate bearing a reference grid immediately in front of the image plane. A polarizing filter attached to the lens of one of the cameras can be rotated in 45° increments for light polarizing studies. On the first EVA, each magazine will carry 160 frames of color film. For the second EVA, each film magazine will contain 200 frames of thin-base black and white film.

A gnomon, used for metric control of near field (less than 10 feet) stereoscopic photography, will provide angular orientation relative to the local vertical. Information on the distances to objects and on the pitch, roll, and azimuth of the camera's optic axis are thereby included in each photograph. The gnomon is a weighted tube suspended vertically on a tripod supported gimbal. The tube extends one foot above the gimbal and is painted with a gray scale in bands one centimeter wide. Photogrammetric techniques will be used to produce three-dimensional models and maps of the lunar surface from the angular and distance relationship between specific objects recorded on the film.

The Apollo black and white surface television camera has two resolution modes (320 scan lines/frame and 1280 scan lines/frame) and two respective scanning modes (10 frames/second and 0.625 frames/second). With the TV camera mounted on a tripod on the lunar surface, the astronauts will be able to conduct the early portion of their traverse within the field of view of the lunar daytime lens. This surveillance will permit Earth-bound advisors to assist in any up-date of pre-mission plans for the lunar surface operations as such assistance is required.

The 16 mm Data Acquisition Camera will provide time-sequence coverage from within the LM. It can be operated in several automatic modes, ranging from 1 frame/second to 24 frames/sec. Shutter speeds, which are independent of the frame rates, range from 1/1000 second to 1/60 second. Time exposures are also possible. While a variety of lenses is provided, the 18 mm lens will be used to record most of the geological activities in the 1 frame/sec mode.

The Lunar Surface Close-up Camera will be used to obtain high resolution stereoscopic photographs of the lunar surface to provide fine scale information on lunar soil and rock textures. Up to 100 stereo pairs can be exposed on the preloaded roll of 35 mm color film. The handle grip enables the astronaut to operate the camera from a standing position. The film drive and electronic flash are battery-operated. The camera photographs a 3"x3" area of the lunar surface.

Geological sampling equipment includes tongs, scoop, hammer, and core tubes. A 24-inch extension handle is provided for several of the tools to aid the astronaut in using them without kneeling.

Sample return containers (SRC) have been provided for return of up to 40 pounds each of lunar material for Earth-based analysis. The SRC's are identical to the ones used on the Apollo 11 mission. They are machined from aluminum forgings and are designed to maintain an internal vacuum during the outbound and return flights. The SRC's will be filled with representative samples of lunar surface material, collected and separately bagged by the astronauts on their traverse and documented by verbal descriptions and photography. Subsurface samples will be obtained by using drive tubes 16 inches long and one inch in diameter. A few grams of material will be preserved under lunar vacuum conditions in a special environmental sample container. This container will be opened for analysis under vacuum conditions equivalent to that at the lunar surface.

### Passive Seismic Experiment (PSE)

The ALSEP Passive Seismic Experiment (PSE) will measure seismic activity of the Moon and obtain information on the physical properties of the lunar crust and interior. The PSE will detect surface tilt produced by tidal deformations, moonquakes, and meteorite impacts.

The passive seismometer design and subsequent experiment analysis are the responsibility of Dr. Gary Latham and Dr. Maurice Ewing - Lamont-Doherty Geological Observatory; Dr. George Sutton - University of Hawaii; and Dr. Frank Press - MIT.

A similar passive seismic experiment, deployed during the Apollo 11 flight, utilized solar energy to produce the power necessary for its operation. Thus, it operated only during the lunar day. The instrument for Apollo 12 utilizes nuclear power and can operate continuously. On Apollo 11, an electronics package served as the base for the seismometer, somewhat isolating the instrument from the lunar surface. The ALSEP instrument for Apollo 12 sits on a leveling stool which provides better contact with the lunar surface. The Apollo 11 seismometer had its own self-contained electronics and transmitter. The Apollo 12 instrument sends its sensor readings to the ALSEP central station which combines the inputs from all the ALSEP experiments into the proper format and transmits the data back to Earth. False signals should be reduced by physically separating the seismometer from the electronics.

After the two astronauts rejoin the command module, the LM ascent stage will be jettisoned toward the lunar surface impacting approximately 5 nautical miles south of the previously emplaced ALSEP Passive Seismometer. This will provide a calibrated seismic event equivalent to one ton of TNT.

There are three major physical components of the PSE:

- . The sensor assembly consists of three long-period seismometers with orthogonally oriented, capacitance type seismic sensors, measuring along two horizontal axes and one vertical axis. This is mounted on a gimbal platform assembly. There is one short period seismometer which has magnet type sensors. It is located directly on the base of the sensor assembly.

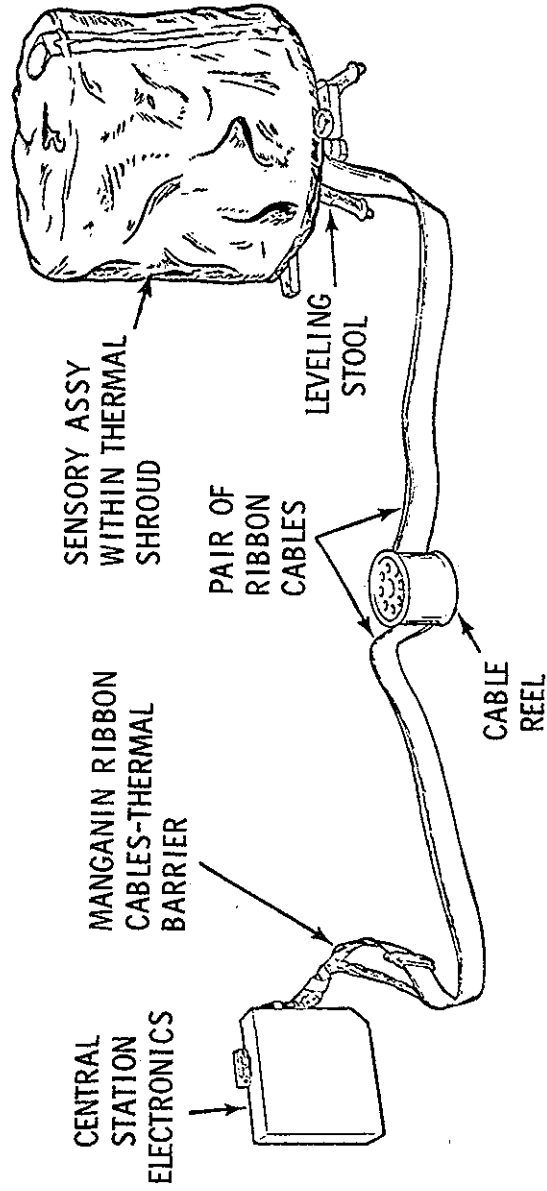

## PASSIVE SEISMIC EXPERIMENT



- . The leveling stool allows manual leveling of the sensor assembly by the astronaut to within  $\pm 5^\circ$ , and final leveling to within 3 arc seconds by control motors.
- . The thermal shroud covers and helps stabilize the temperature of the sensor assembly. Also, two radio-isotope heaters will protect the instrument from the extreme cold of the lunar night.

Dust Detector

The ALSEP Dust Detector is an engineering measurement designed to detect the presence of dust or debris that may impinge on the ALSEP or accumulate during its operating life.

The measurement apparatus consists of three calibrated solar cells, one pointing in east, west and vertical to face the elliptic path of the Sun. The detector is located on the central station.

Dust accumulation on the surface of the three solar cells will reduce the solar illumination detected by the cells. The temperature of each cell will be measured and compared with predicted values.

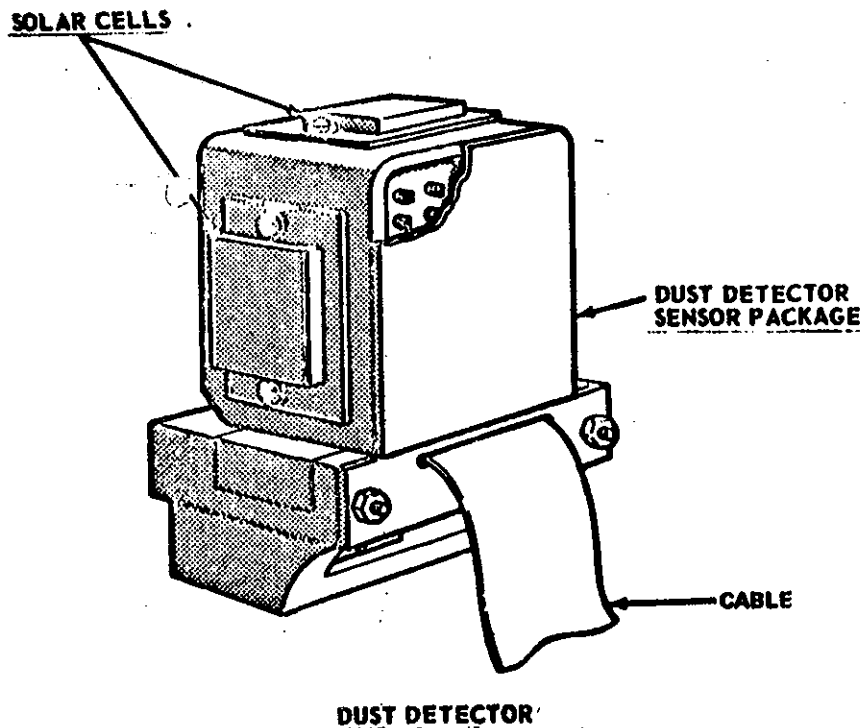

Lunar Multispectral Photography Experiment S-158

The objective of the Lunar Multispectral Photography Experiment is to photograph the lunar surface from orbit at four widely separated wavelengths in the green, blue, red and infrared portions of the spectrum. Four 80mm Hasselblad cameras each with a different filter are to be mounted in a ring attached to the command module hatch window. Black and white film will be used in each camera.

Photography will be carried out during the 27th and 28th lunar orbits by astronaut Richard Gordon while alone in the command module. An automatic device will trip the camera shutters simultaneously at 20 second intervals. Vertical strip photography and photographs of possible future landing sites are planned.

The returned film will be analyzed by both photographic and computer methods to produce specially enhanced color composite prints designed to reveal, at high resolution, subtle color shading on the lunar surface that cannot be perceived by the eye or seen on normal color film. There is good evidence that these color differences are related to compositional variations. The enhanced pictures will aid geologists in planning for future sample collection and aid in extrapolating known compositions from returned samples to other parts of the Moon which will not be visited by man.

The principal investigator is Dr. Alexander F. H. Goetz/Bellcomm, Inc. Co-investigators are Mr. Fred C. Billingsley/Jet Propulsion Laboratory, Dr. Thomas B. McCord/Massachusetts Institute of Technology and Dr. Edward Yost/Long Island University.

SNAP-27

SNAP-27 is one of a series of radioisotope thermo-electric generators, or atomic batteries, developed by the Atomic Energy Commission under its SNAP program. The SNAP (Systems for Nuclear Auxiliary Power) program is directed at development of generators and reactors for use in space, on land and in the sea.

While nuclear heaters were used in the seismometer package on Apollo 11, SNAP-27 on Apollo 12 will mark the first use of a nuclear electrical power system on the Moon. It is designed to provide all the electricity for continuous one-year operation of the NASA Apollo Lunar Surface Experiments Package.

# BOOTSTRAP PHOTOGRAPHY

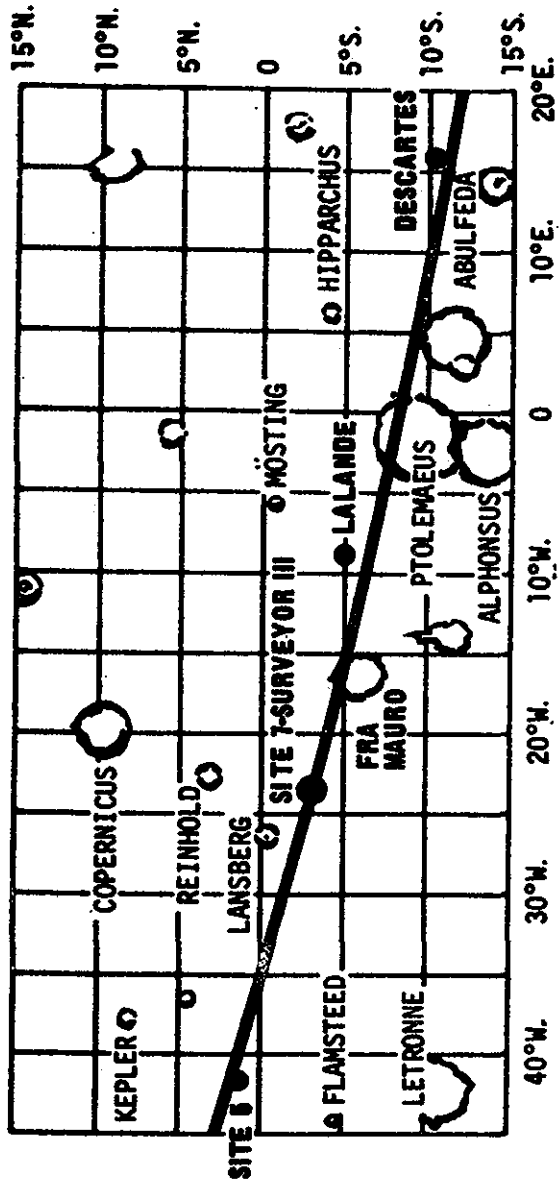

A nuclear power generator of different design is providing part of the power, along with solar cells, for the Nimbus III satellite which was launched in April 1969. Nimbus III represents the first use of a nuclear power system on a NASA spacecraft. Other systems of this type have also been used on Department of Defense navigational satellites. Altogether, eight nuclear power systems, before SNAP-27, have been launched in the United States space program.

The basic SNAP-27 unit is designed to produce at least 63 electrical watts of power for the Apollo 12 lunar surface experiments. It is a cylindrical generator, fueled with the radioisotope plutonium 238. It is about 18 inches high and 16 inches in diameter, including the heat radiating fins. The generator, making maximum use of the lightweight material beryllium, weighs about 28 pounds unfueled.

The fuel capsule, made of a superalloy material, is 16.5 inches long and 2.5 inches in diameter. It weighs about 15.5 pounds, of which 8.36 pounds represent fuel.

The plutonium 238 fuel is fully oxidized and is chemically and biologically inert.

The rugged fuel capsule is contained within a graphite fuel cask from launch through lunar landing. The cask is designed to provide reentry heating protection and added containment for the fuel capsule in the unlikely event of an aborted mission. The cylindrical cask with hemispherical ends includes a primary graphite heat shield, a secondary beryllium thermal shield, and a fuel capsule support structure made of titanium and Inconel materials. The cask is 23 inches long and 8 inches in diameter and weighs about 24.5 pounds. With the fuel capsule installed, it weighs about 40 pounds. It is mounted on the lunar module descent stage by a titanium support structure.

Once the lunar module is on the Moon, an Apollo astronaut will remove the fuel capsule from the cask and insert it into the SNAP-27 generator which will have been placed on the lunar surface near the module.

The spontaneous radioactive decay of the plutonium 238 within the fuel capsule generates heat in the generator. An assembly of 442 lead telluride thermoelectric elements converts this heat -- 1480 thermal watts -- directly into electrical energy -- at least 63 watts. There are no moving parts.

# SNAP-27 GENERATOR

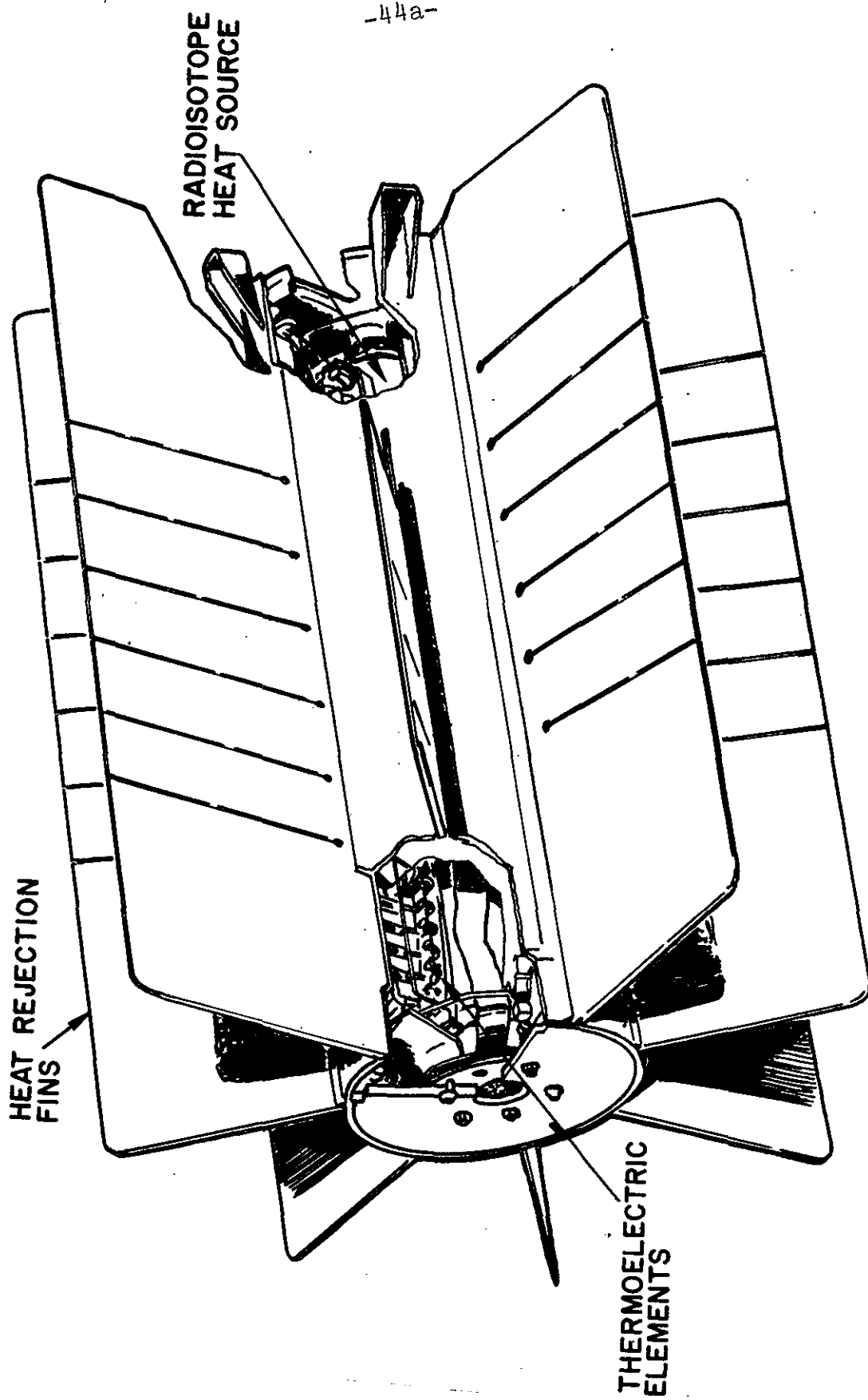

-44a-

-more-

The unique properties of plutonium 238 make it an excellent isotope for use in space nuclear generators. At the end of almost 90 years, plutonium 238 is still supplying half of its original heat. In the decay process, plutonium 238 emits mainly the nuclei of helium (alpha radiation), a very mild type of radiation with a short emission range.

Before the use of the SNAP-27 system in the Apollo program was authorized, a thorough review was conducted to assure the health and safety of personnel involved in the launch and of the general public. Extensive safety analyses and tests were conducted which demonstrated that the fuel would be safely contained under almost all credible accident conditions.

#### Contractors for SNAP-27

General Electric Co., Missile and Space Division, Philadelphia, Pa., designed, developed and fabricated the SNAP-27 generator for the ALSEP.

The 3M Co., St. Paul, Minn., fabricated the thermo-electric elements and assembled the SNAP-27 generator.

Solar Division of International Harvester, San Diego, Calif., fabricated the generator's beryllium structure.

Hitco, Gardena, Calif., fabricated the graphite structure for the SNAP-27 Graphite LM Fuel Cask.

Sandia Corporation, a subsidiary of Western Electric, operator of AEC's Sandia Laboratory, Albuquerque, N.M., provided technical direction for the SNAP-27 program.

Savannah River Laboratory, Aiken, South Carolina, operated by the DuPont Company for the AEC, prepared the raw plutonium fuel.

Mound Laboratory, Miamisburg, Ohio, operated by Monsanto Research Corp., for the AEC, fabricated the raw fuel into the final fuel form and encapsulated the fuel.

## PHOTOGRAPHIC EQUIPMENT

Still and motion pictures will be made of most spacecraft maneuvers, crew lunar surface activities, and mapping photos from orbital altitude to aid in planning future landing missions. During lunar surface activities, emphasis will be on photographic documentation of lunar surface features and lunar material sample collection.

Camera equipment stowed in the Apollo 12 command module consists of one 70mm Hasselblad electric camera for general photography, the four-camera lunar multispectral camera assembly for the S-158 experiment, and a 16mm motion picture camera. The S-158 experiment camera group consists of four Hasselblads side-by-side on a common mount, each fitted with a different filter and type of film. A similar experiment was flown as S-065 Earth multispectral photography on Apollo 9.

S-158 experiment objectives are: gathering of lunar surface color variation data for geologic mapping, correlation of photos with spectral reflectance of returned samples as a possible means of determining surface composition with orbital photography, potential landing site photography (Fra Mauro, Descartes, LaLande), and comparison of lunar reflectance variation and wavelengths.

Cameras stowed on the lunar module are two 70mm Hasselblad data cameras fitted with 60mm Zeiss Metric lens, a 16mm motion picture camera fitted with a 10mm lens, and a closeup stereo camera for geological photos on the lunar surface which is stowed in the MESA on the LM descent stage. The LM Hasselblads have crew chest mounts that leave both hands free.

The command module Hasselblad electric camera is normally fitted with an 80mm f/2.8 Zeiss Planar lens, but bayonet-mount 250mm and 500mm lens may be substituted for special tasks. The 80mm lens has a focussing range from three feet to infinity and has a field of view of 38 degrees vertical and horizontal on the square-format film frame. Accessories for the command module Hasselblad include a spotmeter, intervalometer, remote control cable, and film magazines. Hasselblad shutter speeds range from time exposure and one second to 1/500 second.

The Maurer 16mm motion picture camera in the command module has lenses of 5, 18 and 75mm available. The camera weighs 2.8 pounds with a 130-foot film magazine attached. Accessories include a right-angle mirror, a power cable, and a sextant adapter which allows the camera to use the navigation sextant optical system. This camera will be mounted in the right-hand window to record descent and landing and the two EVA periods.



The 35mm stereo closeup camera stowed in the LM MESA shoots 24mm square stereo pairs with an image scale of one-half actual size. The camera is fixed focus and is equipped with a stand-off hood to position the camera at the proper focus distance. A long handle permits an EVA crewman to position the camera without stooping for surface object photography. Detail as small as 40 microns can be recorded. The camera allows photography of significant surface structure which would remain intact only in the lunar environment, such as fine powdery deposits, cracks or holes, and adhesion of particles. A battery-powered electronic flash provides illumination, and film capacity is a minimum of 100 stereo pairs.

-more-

## LUNAR DESCRIPTION

Terrain - Mountainous and crater-pitted, the former rising as high as 29 thousand feet and the latter ranging from a few inches to 180 miles in diameter. The craters are thought to be formed primarily by the impact of meteorites. The surface is covered with a layer of fine-grained material resembling silt or sand, as well as small rocks and boulders.

Environment - No air, no wind, and no moisture. The temperature ranges from 243 degrees F. in the two-week lunar day to 279 degrees below zero in the two-week lunar night. Gravity is one-sixth that of Earth. Micrometeoroids pelt the Moon since there is no atmosphere to burn them up. Radiation might present a problem during periods of unusual solar activity.

Far Side - The far or hidden side of the Moon no longer is a complete mystery. It was first photographed by a Russian craft and since then has been photographed many times, particularly from NASA's Lunar Orbiter and Apollo spacecraft.

Origin - There is still no agreement among scientists on the origin of the Moon. The three theories: (1) the Moon once was part of Earth and split off into its own orbit, (2) it evolved as a separate body at the same time as Earth, and (3) it formed elsewhere in space and wandered until it was captured by Earth's gravitational field.

### Physical Facts

Diameter	2,160 miles (about 1/4 that of Earth)
Circumference	6,790 miles (about 1/4 that of Earth)
Distance from Earth	238,857 miles (mean; 221,463 minimum to 252,710 maximum)
Surface temperature	+243°F (Sun at zenith) -279°F (night)
Surface gravity	1/6 that of Earth
Mass	1/100th that of Earth
Volume	1/50th that of Earth
Lunar day and night	14 Earth days each
Mean velocity in orbit	2,287 miles-per-hour

Escape velocity                    1.48 miles-per-second  
Month (period of  
rotation around Earth)    27 days, 7 hours, 43 minutes

Apollo 12 Landing Site

The primary landing site for the Apollo 12 is designated Site 7, located in the Ocean of Storms at 2.94° south latitude by 23.45° west longitude -- about 830 nm west of Apollo 11's landing site last July in the Sea of Tranquility.

Should the Apollo 12 launch be delayed beyond November 14, a secondary site at 2° north latitude by 42° west longitude would be targeted for a November 16 launch. The secondary site is designated Site 5.

Apollo 11 landed at Site 2 on July 20, 1969. Actual landing took place at 0°41'15" north latitude by 23°26' east longitude, some 6,870 meters west of the Site 2 ellipse center.

A possible added bonus to a pinpoint Apollo 12 landing will be the Surveyor III spacecraft located on the inner slope of a crater at 3.33° south latitude by 23.17° west longitude, 1,118 feet from the Apollo 12 aiming point. Retrieval of Surveyor components exposed to almost three years in the lunar environment is a low-priority objective of Apollo 12, coming after sample collection, EVA operations, ALSEP deployment, and expansion of lunar exploration begun by Apollo 11.

## SATURN V LAUNCH VEHICLE

The launch vehicle for the Apollo 12 mission is essentially the same as that for Apollo 11. The number of instrumentation measurements, 1,365, on AS-507 is only 17 more than were taken on the vehicle that launched the spacecraft on the first lunar landing mission.

### First Stage

The Marshall Space Flight Center and The Boeing Co. jointly developed the 7.6-million pound thrust first stage (S-IC) of the Saturn V. Major structural components include the forward skirt, oxidizer tank, intertank structure, fuel tank and thrust structure. The normal propellant flow rate to the five F-1 engines is 29,364.5 pounds (2,230 gallons) per second. Four of the engines are mounted on a ring at 90-degree intervals. These four are gimballed to control the rocket's attitude in flight. The fifth engine is mounted rigidly in the center.

### Second Stage

The second stage (S-II) is built by the Space Division of North American Rockwell Corp. at Seal Beach, Calif. Its major structural components include the forward skirt, the liquid hydrogen and liquid oxygen tanks (separated by an insulated common bulkhead), the thrust structure and an interstage section that connects the first and second stages.

Four of the stage's five J-2 engines are mounted on a 17.5-foot diameter ring. These four may be gimballed through a plus or minus seven degree pattern for thrust vector control. The fifth engine is mounted rigidly on the stage centerline.

### Third Stage

The McDonnell Douglas Astronautics Co. at Huntington Beach, Calif. produces the third stage (S-IVB). Its major structural components include aft interstage and skirt, thrust structure, propellant tanks with common bulkhead, forward skirt, and a single J-2 engine.

Insulation between the stage's propellant tanks is necessary because the liquid oxygen, at about 293 degrees below zero Fahrenheit, is warm enough, relatively, to heat the liquid hydrogen, at 423 degrees below zero, and cause excessive vaporization.

The gimballed J-2 engine that powers the stage is capable of a maximum of 230,000 pounds of thrust. On the Apollo 12 mission the thrust range will be from 176,982 to 207,256 pounds. The S-IVB, capable of shutdown and restart, will provide propulsion twice during the Apollo 12 mission.

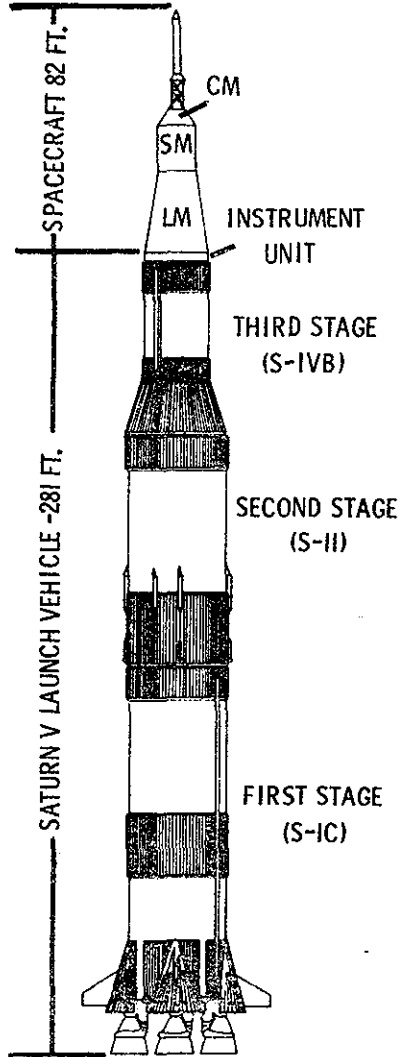

<b>FIRST STAGE (S-IC)</b>	
Diameter -----	33 feet
Height -----	138 feet
Weight -----	5,030,715 lbs. fueled 287,850 lbs. dry
Engines -----	Five F-1
Propellants --	Liquid oxygen (3,308,605 lbs., 340,531 gals.) RP-1 (kerosene) (1,428,855 lbs., 209,792 gals.)
Thrust -----	7,620,427 lbs. at liftoff
<b>SECOND STAGE (S-II)</b>	
Diameter -----	33 feet
Height -----	81.5 feet
Weight -----	1,060,420 lbs. fueled 80,220 lbs. dry
Engines -----	Five J-2
Propellants --	Liquid oxygen (820,710 lbs., 86,208 gals.) liquid hydrogen (158,230 lbs., 282,543 gals.)
Thrust -----	1,101,135 to 1,161,414 lbs.
Interstages --	11,465
<b>THIRD STAGE (S-IVB)</b>	
Diameter -----	21.7 feet
Height -----	58.3 feet
Weight -----	262,070 lbs. fueled 25,050 lbs. dry
Engine -----	One J-2
Propellants --	Liquid oxygen (189,900 lbs., 19,766 gals.) Liquid hydrogen (43,500 lbs., 77,671 gals.)
Thrust -----	176,982 to 207,256 lbs.
Interstage ---	8,035 lbs.
<b>INSTRUMENT UNIT</b>	
Diameter -----	21.7 feet
Height -----	3 feet
Weight -----	4,275 lbs.

NOTE: Weights and measures given above are for the nominal vehicle configuration for Apollo 12. The figures may vary slightly due to changes before launch to meet changing conditions. Weights of dry stages and propellants do not equal total weight because frost and miscellaneous smaller items are not included in chart.

## Instrument Unit

The instrument unit (IU) contains the navigation, guidance and control equipment to steer the vehicle through its Earth orbits and into the final translunar trajectory maneuver. The six major systems are structural, thermal control, guidance and control, measuring and telemetry, radio frequency, and electrical.

In addition to navigation, guidance, and control of the vehicle the instrument unit provides measurement of the vehicle performance and environment; data transmission with ground stations; radio tracking of the vehicle; checkout and monitoring of vehicle functions; initiation of stage functional sequencing; detection of emergency situations; power storage and network distribution of its electric power system; and checkout of pre-flight, launch and flight functions.

A path-adaptive guidance scheme is used in the Saturn V instrument unit. A programmed trajectory is used during first stage boost with guidance beginning only after the vehicle has left the atmosphere. This prevents movements that might cause the vehicle to break apart while attempting to compensate for winds, jet streams, and gusts encountered in the atmosphere.

If after second stage ignition the vehicle deviates from the optimum trajectory in climb, the vehicle derives and corrects to a new trajectory.

The ST-124M inertial platform--the heart of the navigation, guidance and control system--provides space-fixed reference coordinates and measures acceleration along the three mutually perpendicular axes of the coordinate system. If the inertial platform fails during boost, spacecraft systems continue guidance and control functions for the rocket. After second stage ignition the crew can manually steer the space vehicle.

International Business Machines Corp., is prime contractor for the instrument unit.

## Propulsion

The 37 rocket engines of the Saturn V have thrust ratings ranging from 70 pounds to more than 1.5 million pounds. Some engines burn liquid propellants, others use solids.

Engines in the first stage develop approximately 1,524,085 pounds of thrust each at liftoff, building up to about 1,808,508 pounds before cutoff. The cluster of five engines gives the first stage a thrust range of from 7,620,427 pounds at liftoff to 9,042,041 pounds just before center engine cutoff.

The F-1 engine weighs almost 10 tons, is more than 18 feet high and has a nozzle-exit diameter of nearly 14 feet. The engine consumes almost three tons of propellant per second.

The first stage has eight solid-fuel retrorockets which separate the stage from the second stage. Each rocket produces a thrust of 87,900 pounds for 0.6 second.

The second stage engine thrust varies from 220,227 to 232,283 during this flight. The 3,500-pound J-2 is more efficient than the F-1 because it burns the high-energy fuel hydrogen. F-1 and J-2 engines are produced by the Rocketdyne Division of North American Rockwell Corp.

The second stage has four 21,000-pound-thrust solid fuel ullage rockets to settle liquid propellant in the bottom of the main tanks and help attain a "clean" separation from the first stage. Four retrorockets are located in the S-IVB aft interstage (which never separates from the S-II) to separate the S-II from the S-IVB. There are two jettisonable ullage rockets for propellant settling prior to engine ignition. Eight smaller engines in the two auxiliary propulsion system modules on the S-IVB stage provide 3-axis attitude control.

## COMMAND AND SERVICE MODULE STRUCTURE, SYSTEMS

The Apollo spacecraft for the Apollo 12 mission is comprised of Command Module 108, Service Module 108, Lunar Module 6, a spacecraft-lunar module adapter (SLA) and a launch escape system. The SLA houses the lunar module and serves as a mating structure between the Saturn V instrument unit and the LM.

Launch Escape System (LES) -- Propels command module to safety in an aborted launch. It has three solid-propellant rocket motors: a 147,000 pound-thrust launch escape system motor, a 2,400-pound-thrust pitch control motor, and a 31,500 pound-thrust tower jettison motor. Two canard vanes deploy to turn the command module aerodynamically to an attitude with the heat-shield forward. The system is 33 feet tall, four feet in diameter at the base, and weighs 8,945 pounds.

Command Module (CM) Structure -- The command module is a pressure vessel encased in heat shields, cone-shaped, weighing 12,365 pounds.

The command module consists of a forward compartment which contains two reaction control engines and components of the Earth landing system; the crew compartment or inner pressure vessel containing crew accommodations, controls and displays, and many of the spacecraft systems; and the aft compartment housing ten reaction control engines, propellant tankage, helium tanks, water tanks, and the CSM umbilical cable. The crew compartment contains 210 cubic feet of habitable volume.

Heat-shields around the three compartments are made of brazed stainless steel honeycomb with an outer layer of phenolic epoxy resin as an ablative material.

CSM 108 and LM-6 are equipped with the probe-and-drogue docking hardware. The probe assembly is a powered folding coupling and impact attenuating device mounted in the CM tunnel that mates with a conical drogue mounted in the LM docking tunnel. After the 12 automatic docking latches are checked following a docking maneuver, both the probe and drogue are removed to allow crew transfer between the CSM and LM.

Service Module (SM) Structure -- The service module for the Apollo 12 mission will weigh 51,105 pounds. Aluminum honeycomb panels one inch thick form the outer skin, and milled aluminum radial beams separate the interior into six sections around a central cylinder containing two helium spheres, four sections containing service propulsion system fuel-oxidizer tankage, another containing fuel cells, cryogenic oxygen and hydrogen, and one sector essentially empty.



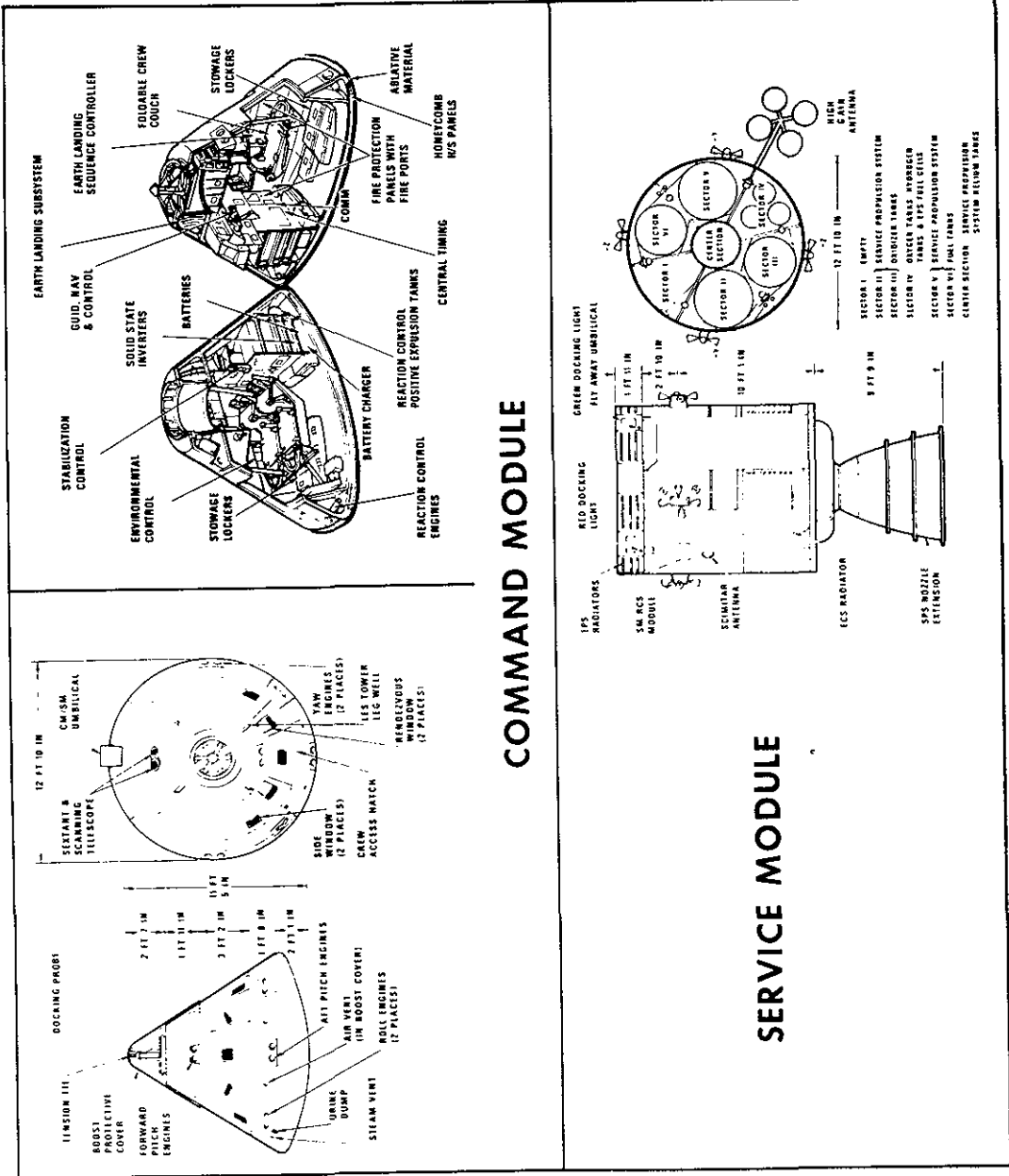

COMMAND MODULE

SERVICE MODULE

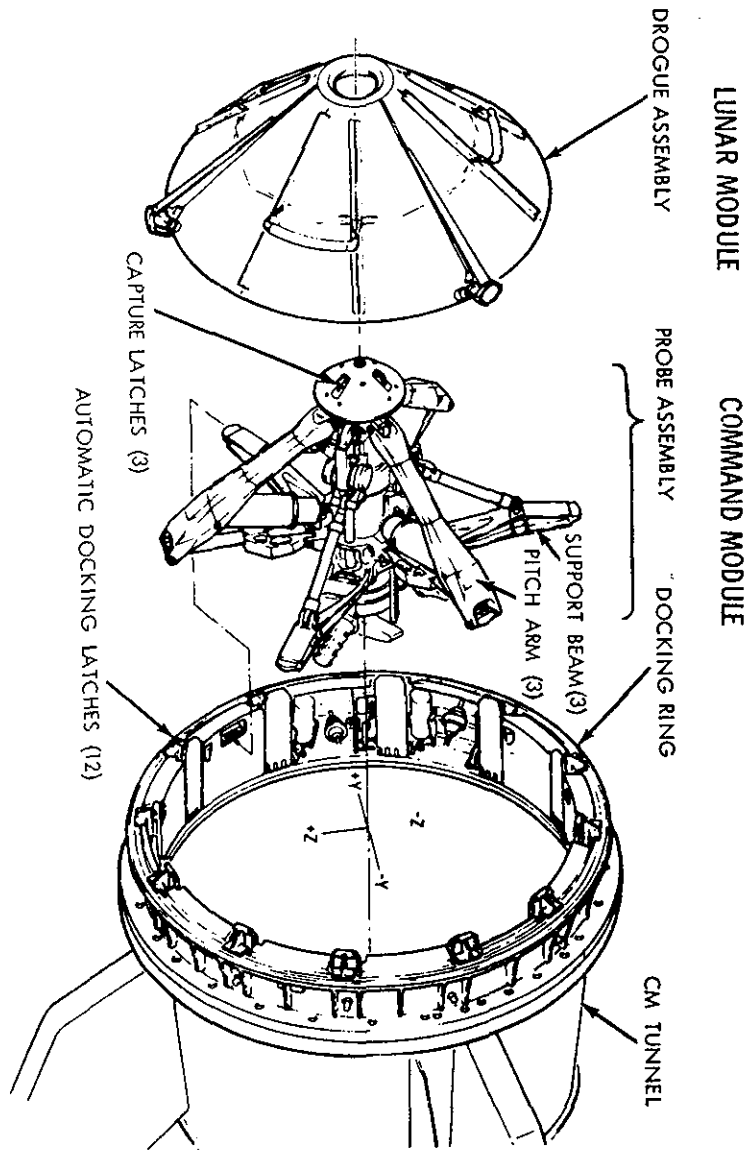

# APOLLO DOCKING MECHANISMS

Spacecraft-LM Adapter (SLA) Structure -- The spacecraft LM adapter is a truncated cone 28 feet long tapering from 260 inches diameter at the base to 154 inches at the forward end at the service module mating line. The SLA weighs 4,000 pounds and houses the LM during launch and Earth orbital flight.

### CSM Systems

Guidance, Navigation and Control System (GNCS) -- Measures and controls spacecraft position, attitude, and velocity, calculates trajectory, controls spacecraft propulsion system thrust vector, and displays abort data. The guidance system consists of three subsystems: Inertial, made up of an inertial measurement unit and associated power and data components; computer which processes information to or from other components; and optics consisting of scanning telescope and sextant for celestial and/or landmark sighting for spacecraft navigation. VHF ranging device serves as a backup to the LM rendezvous radar.

Stabilization and Control Systems (SCS) -- Controls spacecraft rotation, translation, and thrust vector and provides displays for crew-initiated maneuvers; backs up the guidance system for control functions. It has three subsystems; attitude reference, attitude control, and thrust vector control.

Service Propulsion System (SPS) -- Provides thrust for large spacecraft velocity changes through a gimbal-mounted 20,5000-pound-thrust hypergolic engine using a nitrogen tetroxide oxidizer and a 50-50 mixture of unsymmetrical dimethyl hydrazine and hydrazine fuel. This system is in the service module. The system responds to automatic firing commands from the guidance and navigation system or to manual commands from the crew. The engine thrust level is not throttleable. The stabilization and control system gimbals the engine to direct the thrust vector through the spacecraft center of gravity.

Telecommunications System -- Provides voice, television, telemetry, and command data and tracking and ranging between the spacecraft and Earth, between the command module and the lunar module and between the spacecraft and the extravehicular astronaut. It also provides intercommunications between astronauts.

The high-gain steerable S-Band antenna consists of four, 31-inch-diameter parabolic dishes mounted on a folding boom at the aft end of the service module. Signals from the ground stations can be tracked either automatically or manually with the antenna's gimbaling system. Normal S-Band voice and uplink/downlink communications will be handled by the omni and high-gain antennas.

Sequential System -- Interfaces with other spacecraft systems and subsystems to initiate time critical functions during launch, docking maneuvers, sub-orbital aborts, and entry portions of a mission. The system also controls routine spacecraft sequencing such as service module separation and deployment of the Earth landing system.

Emergency Detection System (EDS) -- Detects and displays to the crew launch vehicle emergency conditions, such as excessive pitch or roll rates or two engines out, and automatically or manually shuts down the booster and activates the launch escape system; functions until the spacecraft is in orbit.

Earth Landing System (ELS) -- Includes the drogue and main parachute system as well as post-landing recovery aids. In a normal entry descent, the command module forward heat shield is jettisoned at 24,000 feet, permitting mortar deployment of two reefed 16.5-foot diameter drogue parachutes for orienting and decelerating the spacecraft. After disreef and drogue release, three mortar deployed pilot chutes pull out the three main 83.3-foot diameter parachutes with two-stage reefing to provide gradual inflation in three steps. Two main parachutes out of three can provide a safe landing.

Reaction Control System (RCS) -- The SM RCS has four identical RCS "quads" mounted around the SM 90 degrees apart. Each quad has four 100 pound-thrust engines, two fuel and two oxidizer tanks and a helium pressurization sphere. Attitude control and small velocity maneuvers are made with the SM RCS.

The CM RCS consists of two independent six-engine subsystems of six 93 pound-thrust engines each used for spacecraft attitude control during entry. Propellants for both CM and SM RCS are monomethyl hydrazine fuel and nitrogen tetroxide oxidizer with helium pressurization. These propellants burn spontaneously when combined (without an igniter).

Electrical Power System (EPS) -- Provides electrical energy sources, power generation and control, power conversion and conditioning, and power distribution to the spacecraft. The primary source of electrical power is the fuel cells mounted in the SM. The fuel cell also furnishes drinking water to the astronauts as a by-product of the fuel cells.

Three silver-zinc oxide storage batteries supply power to the CM during entry and after landing, provide power for sequence controllers, and supplement the fuel cells during periods of peak power demand. A battery charger assures a full charge prior to entry.

Two other silver-zinc oxide batteries supply power for explosive devices for CM/SM separation, parachute deployment and separation, third-stage separation, launch escape system tower separation, and other pyrotechnic uses.

Environmental Control System (ECS) -- Controls spacecraft atmosphere, pressure, and temperature and manages water. In addition to regulating cabin and suit gas pressure, temperature and humidity, the system removes carbon dioxide, odors and particles, and ventilates the cabin after landing. It collects and stores fuel cell potable water for crew use, supplies water to the glycol evaporators for cooling, and dumps surplus water overboard through the waste H<sub>2</sub>O dump nozzle. Proper operating temperature of electronics and electrical equipment is maintained by this system through the use of the cabin heat exchangers, the space radiators, and the glycol evaporators.

Recovery Aids -- Recovery aids include the uprighting system, swimmer interphone connections, sea dye marker, flashing beacon, VHF recovery beacon, and VHF transceiver. The uprighting system consists of three compressor-inflated bags to upright the spacecraft if it should land in the water apex down (stable II position).

Caution and Warning System -- Monitors spacecraft systems for out-of-tolerance conditions and alerts crew by visual and audible alarms.

Controls and Displays -- Provide status readouts and control functions of spacecraft systems in the command and service modules. All controls are designed to be operated by crewmen in pressurized suits. Displays are grouped by system and located according to the frequency of use and crew responsibility.

Command and Service Module Modifications -- Differences between the Apollo 12 CSM 108 and CSM 107 flown on Apollo 11 are as follows:

\* Arc suppression networks have been added at each SM RCS engine to protect CSM electronic systems from electromagnetic interference produced by RCS heater cycling.

\* Hydrogen separator has been added to water subsystem to prevent hydrogen gas from entering potable water tank. (CSM 107 had the hydrogen separator mounted on the hand water dispenser in the cabin.)

\* The S-Band squelch override switch has been moved from the lower equipment bay to the display and control panel for easier crew access.

\* The recovery loop for spacecraft retrieval has been strengthened to obviate the requirement for the swimmer to install an auxiliary loop.

## LUNAR MODULE STRUCTURES, WEIGHT

The lunar module is a two-stage vehicle designed for space operations near and on the Moon. The lunar module stands 22 feet 11 inches high and is 31 feet wide (diagonally across landing gear). The ascent and descent stages of the LM operate as a unit until staging, when the ascent stage functions as a single spacecraft for rendezvous and docking with the CM.

### Ascent Stage

Three main sections make up the ascent stage: the crew compartment, midsection, and aft equipment bay. Only the crew compartment and midsection are pressurized (4.8 psig). The cabin volume is 235 cubic feet (6.7 cubic meters). The stage measures 12 feet 4 inches high by 14 feet 1 inch in diameter. The ascent stage has six substructural areas: crew compartment, midsection, aft equipment bay, thrust chamber assembly cluster supports, antenna supports and thermal and micrometeoroid shield.

The cylindrical crew compartment is 92 inches (2.35 m) in diameter and 42 inches (1.07 m) deep. Two flight stations are equipped with control and display panels, armrests, body restraints, landing aids, two front windows, an overhead docking window, and an alignment optical telescope in the center between the two flight stations. The habitable volume is 160 cubic feet.

A tunnel ring atop the ascent stage meshes with the command module docking latch assemblies. During docking, the CM docking ring and latches are aligned by the LM drogue and the CSM probe.

The docking tunnel extends downward into the midsection 16 inches (40 cm). The tunnel is 32 inches (0.81 m) in diameter and is used for crew transfer between the CSM and LM. The upper hatch on the inboard end of the docking tunnel opens inward and cannot be opened without equalizing pressure on both hatch surfaces.

A thermal and micrometeoroid shield of multiple layers of mylar and a single thickness of thin aluminum skin encases the entire ascent stage structure.

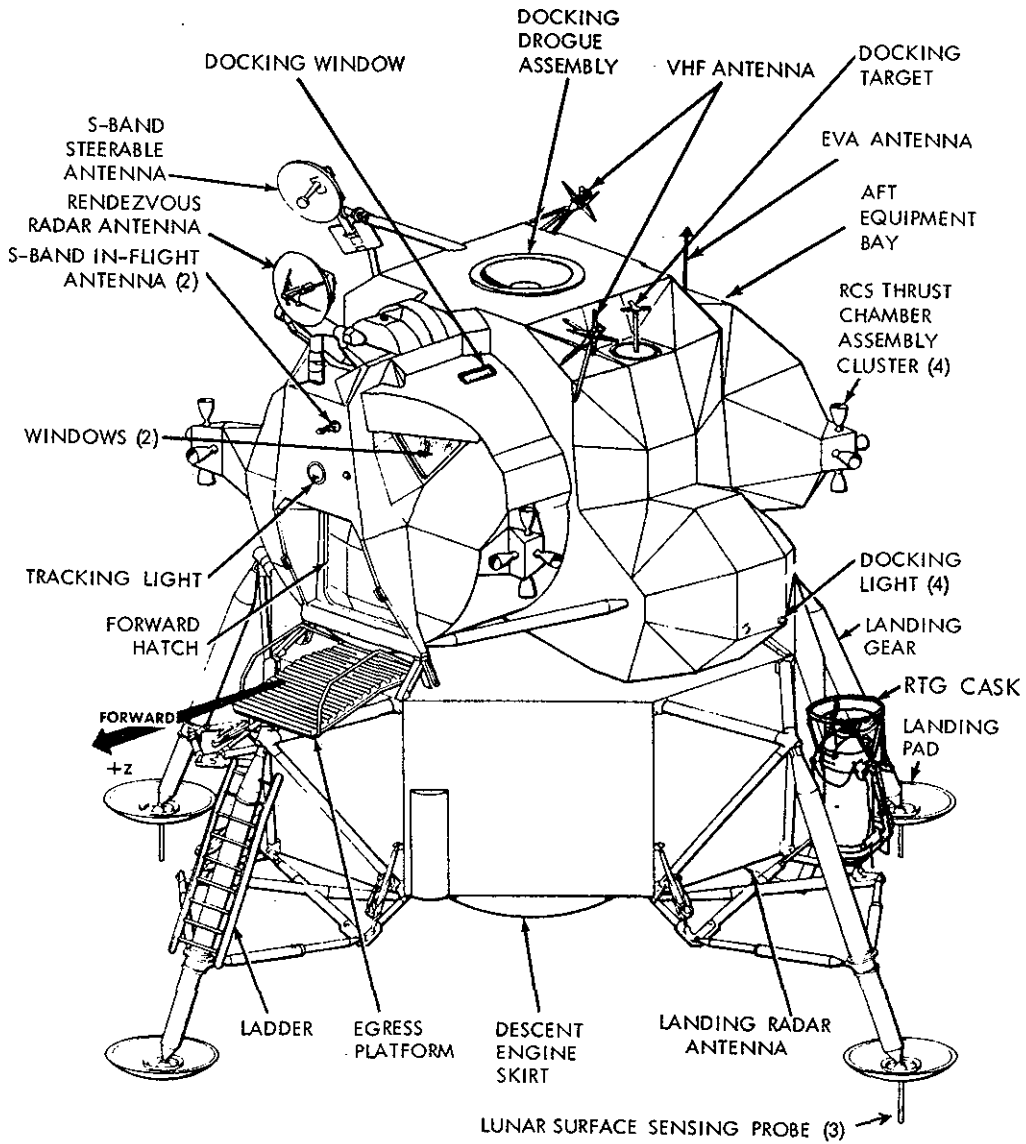

## APOLLO LUNAR MODULE



### Descent Stage

The descent stage center compartment houses the descent engine, and descent propellant tanks are housed in the four square bays around the engine. Quadrant II (Seq bay) contains ALSEP, and Radioisotope Thermoelectric Generator (RTG) externally. Quadrant IV contains the MESA. The descent stage measures 10 feet 7 inches high by 14 feet 1 inch in diameter and is encased in the mylar and aluminum alloy thermal and micrometeoroid shield.

The LM egress platform, or "porch", is mounted on the forward outrigger just below the forward hatch. A ladder extends down the forward landing gear strut from the porch for crew lunar surface operations.

The landing gear struts are explosively extended and provide lunar surface landing impact attenuation. The main struts are filled with crushable aluminum honeycomb for absorbing compression loads. Footpads 37 inches (0.95 m) in diameter at the end of each landing gear provide vehicle support on the lunar surface.

Each pad (except forward pad) is fitted with a 68 inch long lunar surface sensing probe which signals the crew to shut down the descent engine upon contact with the lunar surface.

LM-6 flown on the Apollo 12 mission has a launch weight of 33,325 pounds. The weight breakdown is as follows:

Ascent stage, dry	4,760 lbs.	Includes water and oxygen; no crew
Descent stage, dry	4,875 lbs.	
RCS propellants (loaded)	595 lbs.	
DPS propellants (loaded)	17,925 lbs.	
APS propellants (loaded)	<u>5,170 lbs.</u>	
	33,325 lbs.	

### Lunar Module Systems

Electrical Power System -- The LM DC electrical system consists of six silver zinc primary batteries -- four in the descent stage and two in the ascent stage. Twenty-eight - volt DC power is distributed to all LM systems. AC power (117v 400 Hz) is supplied by two inverters.

Environmental Control System -- Consists of the atmosphere revitalization section, oxygen supply and cabin pressure control section, water management, heat transport section, and outlets for oxygen and water reserVICING of the portable life support system (PLSS).

Components of the atmosphere revitalization section are the suit circuit assembly which cools and ventilates the pressure garments, reduces carbon dioxide levels, removes odors, noxious gases and excessive moisture; the cabin recirculation assembly which ventilates and controls cabin atmosphere temperatures; and the steam flex duct which vents to space steam from the suit circuit water evaporator.

The oxygen supply and cabin pressure section supplies gaseous oxygen to the atmosphere revitalization section for maintaining suit and cabin pressure. The descent stage oxygen supply provides descent flight phase and lunar stay oxygen needs, and the ascent stage oxygen supply provides oxygen needs for the ascent and rendezvous flight phase.

Water for drinking, cooling, fire fighting, food preparation, and refilling the PLSS cooling water servicing tank is supplied by the water management section. The water is contained in three nitrogen-pressurized bladder-type tanks, one of 367-pound capacity in the descent stage and two of 47.5-pound capacity in the ascent stage.

The heat transport section has primary and secondary water-glycol solution coolant loops. The primary coolant loop circulates water-glycol for temperature control of cabin and suit circuit oxygen and for thermal control of batteries and electronic components mounted on cold plates and rails. If the primary loop becomes inoperative, the secondary loop circulates coolant through the rails and cold plates only. Suit circuit cooling during secondary coolant loop operation is provided by the suit loop water boiler. Waste heat from both loops is vented overboard by water evaporation or sublimators.

Crew hammocks and blankets have been provided on LM-6 to give the crew a more comfortable environment for sleep between the EVA periods.

Communications System -- Two S-band transmitter-receivers, two VHF transmitter-receivers, a signal processing assembly, and associated spacecraft antenna make up the LM communications system. The system transmits and receives voice, tracking and ranging data, and transmits telemetry data on about 270 measurements and TV signals to the ground. Voice communications between the LM and ground stations is by S-band, and between the LM and CSM voice is on VHF.

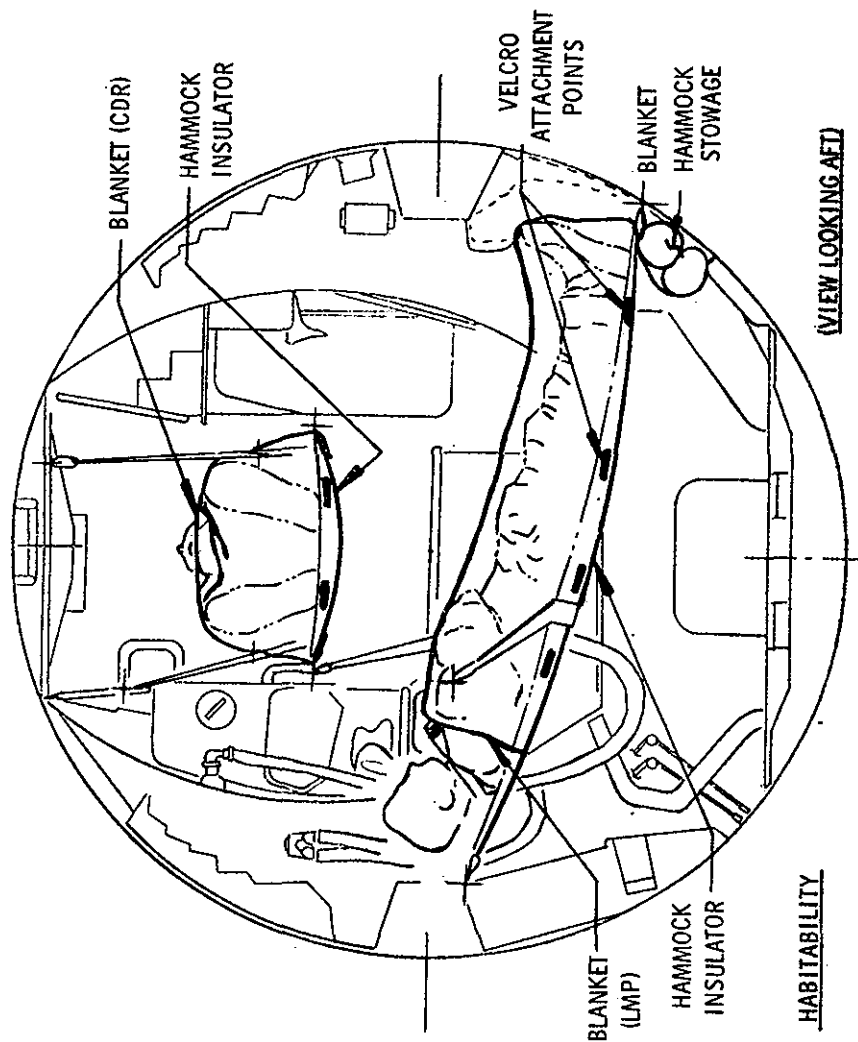

Although no real-time commands can be sent to the LM, the digital uplink processes guidance officer commands transmitted from Mission Control Center to the LM guidance computer, such as state vector updates.

The data storage electronics assembly (DSEA) is a four-channel voice recorder with timing signals with a 10-hour recording capacity which will be brought back into the CSM for return to Earth. DSEA recordings cannot be "dumped" to ground stations.

LM antennas are one 26-inch diameter parabolic S-band steerable antenna, two S-band inflight antennas, two VHF inflight antennas, EVA antenna and an erectable S-band antenna (optional) for lunar surface.

Guidance, Navigation and Control System -- Comprised of six sections: primary guidance and navigation section (PGNS), abort guidance section (AGS), radar section, control electronics section (CES), and orbital rate drive electronics for Apollo and LM (ORDEAL).

\* The PGNS is an aided inertial guidance system updated by the alignment optical telescope, an inertial measurement unit, and the rendezvous and landing radars. The system provides inertial reference data for computations, produces inertial alignment reference by feeding optical sighting data into the LM guidance computer, displays position and velocity data, computes LM-CSM rendezvous data from radar inputs, controls attitude and thrust to maintain desired LM trajectory, and controls descent engine throttling and gimbaling.

The LM-6 primary guidance computer has the Luminary 1B Software program, which is an improved version over that in LM-5.

\* The AGS is an independent backup system for the PGNS, having its own inertial sensors and computer.

\* The radar section is made up of the rendezvous radar which provides CSM range and range rate, and line-of-sight angles for maneuver computation to the LM guidance computer; the landing radar which provide altitude and velocity data to the LM guidance computer during lunar landing. The rendezvous radar has an operating range from 80 feet to 400 nautical miles. The ranging tone transfer assembly, utilizing VHF electronics, is a passive responder to the CSM VHF ranging device and is a backup to the rendezvous radar.

\* The CES controls LM attitude and translation about all axes. It also controls by PGNS command the automatic operation of the ascent and descent engine and the reaction control thrusters. Manual attitude controller and thrust-translation controller commands are also handled by the CES.

\* ORDEAL, displays on the flight director attitude indicator, is the computed local vertical in the pitch axis during circular Earth or lunar orbits.

Reaction Control System -- The LM has four RCS engine clusters of four 100-pound (45.4 kg) thrust engines each of which use helium-pressurized hypergolic propellants. The oxidizer is nitrogen tetroxide, fuel is Aerozine 50 (50/50 blend of hydrazine and unsymmetrical dimethyl hydrazine). Interconnect valves permit the RCS system to draw from ascent engine propellant tanks.

The RCS provides small stabilizing impulses during ascent and descent burns, controls LM attitude during maneuvers, and produces thrust for separation, and ascent/descent engine tank ullage. The system may be operated in either the pulse or steady-state modes.

Descent Propulsion System -- Maximum rated thrust of the descent engine is 9,870 pounds (4,380.9 kg) and is throttleable between 1,050 pounds (476.7 kg) and 6,300 pounds (2,860.2 kg). The engine can be gimballed six degrees in any direction in response to attitude commands and for compensates center of gravity offsets. Propellants are helium-pressurized Aerozine 50 and nitrogen tetroxide.

Ascent Propulsion System -- The 3,500-pound (1,589 kg) thrust ascent engine is not gimballed and performs at full thrust. The engine remains dormant until after the ascent stage separates from the descent stage. Propellants are the same as are burned by the RCS engines and the descent engine.

Caution and Warning, Controls and Displays -- These two systems have the same function aboard the lunar module as they do aboard the command module (See CSM systems section.)

Tracking and Docking Lights -- A flashing tracking light (once per second, 20 milliseconds duration) on the front face of the lunar module is an aid for contingency CSM-active rendezvous LM rescue. Visibility ranges from 400 nautical miles through the CSM sextant to 130 miles with the naked eye. Five docking lights analogous to aircraft running lights are mounted on the LM for CSM-active rendezvous: two forward yellow lights, aft white light, port red light and starboard green light. All docking lights have about a 1,000-foot visibility.

Lunar Module Modifications -- Differences between the Apollo 12 LM-6 and LM-5 flown on Apollo 11 are as follows:

\* The communications system signal processor assembly has been modified to filter out unwanted signals on the intercom circuit and on S-Band backup voice.

\* The rendezvous radar antenna has been modified to reduce cyclical range errors.

\* In the cabin, the radiation survey meter and bracket have been removed, and the oxygen purge system (OPS) pallet assembly has been modified for direct attachment of the OPS. The descent stage OPS pallet adapter has been eliminated. Provision for two crew sleeping hammocks has been made.

\* The descent stage structure has been modified for installation of the Apollo Lunar Surface Experiment Package (ALSEP).

APOLLO 12 CREW

Life Support Equipment - Space Suits

Apollo 12 crewmen will wear two versions of the Apollo space suit: an intravehicular pressure garment assembly worn by the command module pilot and the extravehicular pressure garment assembly worn by the commander and the lunar module pilot. Both versions are basically identical except that the extravehicular version has an integral thermal/meteoroid garment over the basic suit.

From the skin out, the basic pressure garment consists of a nomex comfort layer, a neoprene-coated nylon pressure bladder and a nylon restraint layer. The outer layers of the intravehicular suit are, from the inside out, nomex and two layers of Teflon-coated Beta cloth. The extravehicular integral thermal/meteoroid cover consists of a liner of two layers of neoprene-coated nylon, seven layers of Beta/Kapton spacer laminate, and an outer layer of Teflon-coated Beta fabric.

The extravehicular suit, together with a liquid cooling garment, portable life support system (PLSS), oxygen purge system, lunar extravehicular visor assembly and other components make up the extravehicular mobility unit (EMU). The EMU provides an extravehicular crewman with life support for a four-hour mission outside the lunar module without replenishing expendables. EMU total weight is 183 pounds. The intravehicular suit weighs 35.6 pounds.

Liquid cooling garment--A knitted nylon-spandex garment with a network of plastic tubing through which cooling water from the PLSS is circulated. It is worn next to the skin and replaces the constant wear-garment during EVA only.

Portable life support system--A backpack supplying oxygen at 3.9 psi and cooling water to the liquid cooling garment. Return oxygen is cleansed of solid and gas contaminants by a lithium hydroxide canister. The PLSS includes communications and telemetry equipment, displays and controls, and a main power supply. The PLSS is covered by a thermal insulation jacket. (Two stowed in LM).

Oxygen purge system--Mounted atop the PLSS, the oxygen purge system provides a contingency 30-minute supply of gaseous oxygen in two two-pound bottles pressurized to 5,880 psia. The system may also be worn separately on the front of the pressure garment assembly torso. It serves as a mount for the VHF antenna for the PLSS. (Two stowed in LM).

## EXTRAVEHICULAR MOBILITY UNIT

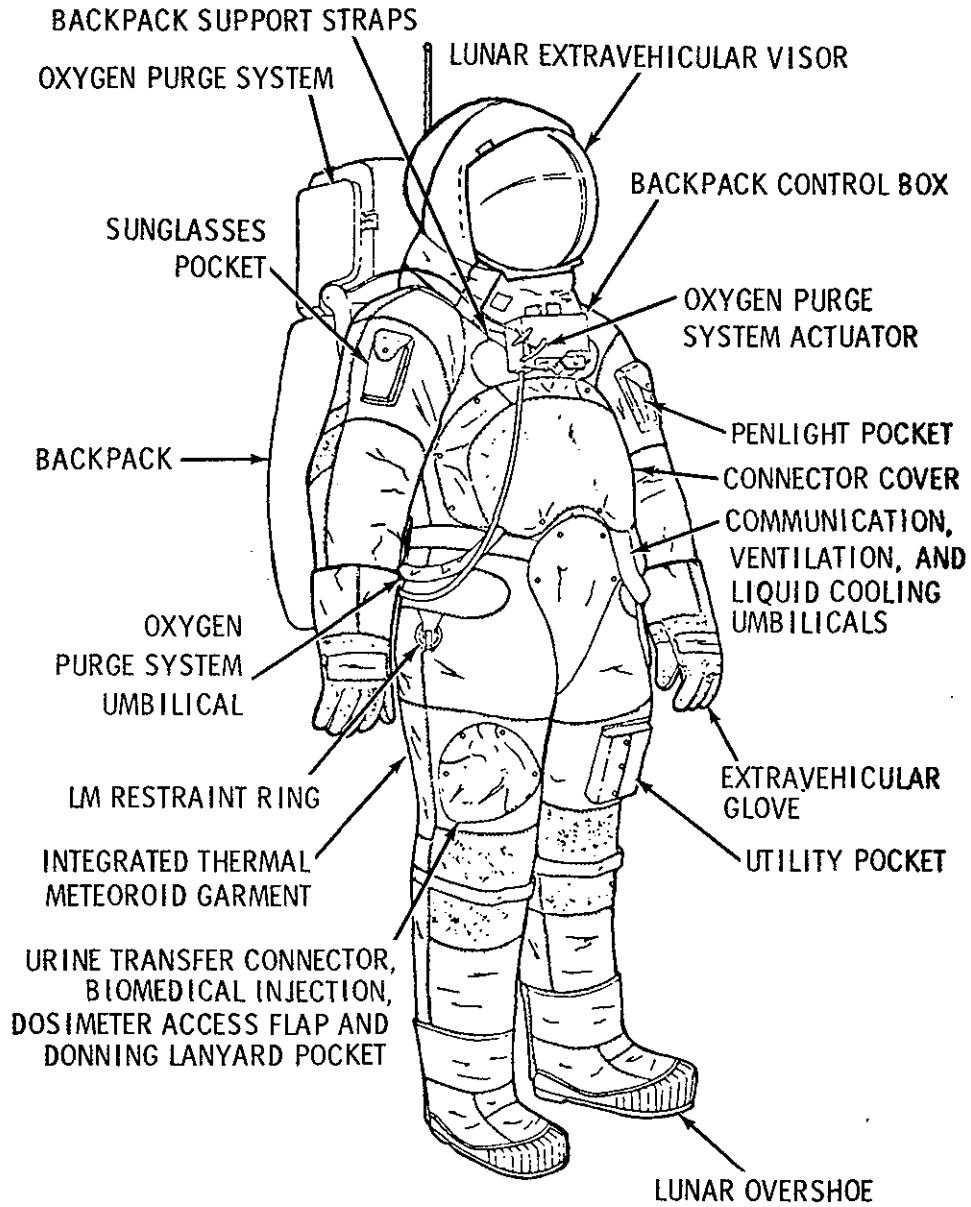



Lunar extravehicular visor assembly--A polycarbonate shell and two visors with thermal control and optical coatings on them. The EVA visor is attached over the pressure helmet to provide impact, micrometeoroid, thermal and ultraviolet-infrared light protection to the EVA crewmen.

Extravehicular gloves--Built of an outer shell of Chromel-R fabric and thermal insulation to provide protection when handling extremely hot and cold objects. The finger tips are made of silicone rubber to provide more sensitivity.

A one-piece constant-wear garment, similar to "long johns", is worn as an undergarment for the space suit in intravehicular operations and for the inflight coveralls. The garment is porous-knit cotton with a waist-to-neck zipper for donning. Biomedical harness attach points are provided.

During periods out of the space suits, crewmen will wear two-piece Teflon fabric inflight coveralls for warmth and for pocket stowage of personal items.

Communications carriers ("Snoopy Hats") with redundant microphones and earphones are worn with the pressure helmet; a lightweight headset is worn with the inflight coveralls.

## Apollo Lunar Hand Tools

Special Environmental Container - The special environmental sample is collected in a carefully selected area and sealed in a special container which will retain a high vacuum. The container is opened in the Lunar Receiving Laboratory where it will provide scientists the opportunity to study lunar material in its original environment.

Extension handle - This tool is of aluminum alloy tubing with a malleable stainless steel cap designed to be used as an anvil surface. The handle is designed to be used as an extension for several other tools and to permit their use without requiring the astronaut to kneel or bend down. The handle is approximately 24 inches long and 1 inch in diameter. The handle contains the female half of a quick disconnect fitting designed to resist compression, tension, torsion, or a combination of these loads. Also incorporated are a sliding T handle at the top and an internal mechanism operated by a rotating sleeve which is used with the aseptic collection device.

Four core tubes - These tubes are designed to be driven or augered into loose gravel, sandy material, or into soft rock such as feather rock or pumice. They are about 15 inches in length and one inch in diameter and are made of aluminum tube. Each tube is supplied with a removeable non-serrated cutting edge and a screw-on cap incorporating a metal-to-metal crush seal which replaces the cutting edge. The upper end of each tube is sealed and designed to be used with the extension handle or as an anvil. Incorporated into each tube is a spring device to retain loose materials in the tube.

Scoops (large and small) - This tool is designed for use as a trowel and as a chisel. The scoop is fabricated primarily of aluminum with a hardened-steel cutting edge riveted on and a nine-inch handle. A malleable stainless steel anvil is on the end of the handle. The angle between the scoop pan and the handle allows a compromise for the dual use. The scoop is used either by itself or with the extension handle.

Sampling hammer - This tool serves three functions, as a sampling hammer, as a pick or mattock, and as a hammer to drive the core tubes or scoop. The head has a small hammer face on one end, a broad horizontal blade on the other, and large hammering flats on the sides. The handle is fourteen inches long and is made of formed tubular aluminum. The hammer has on its lower end a quick-disconnect to allow attachment to the extension handle for use as a hoe.

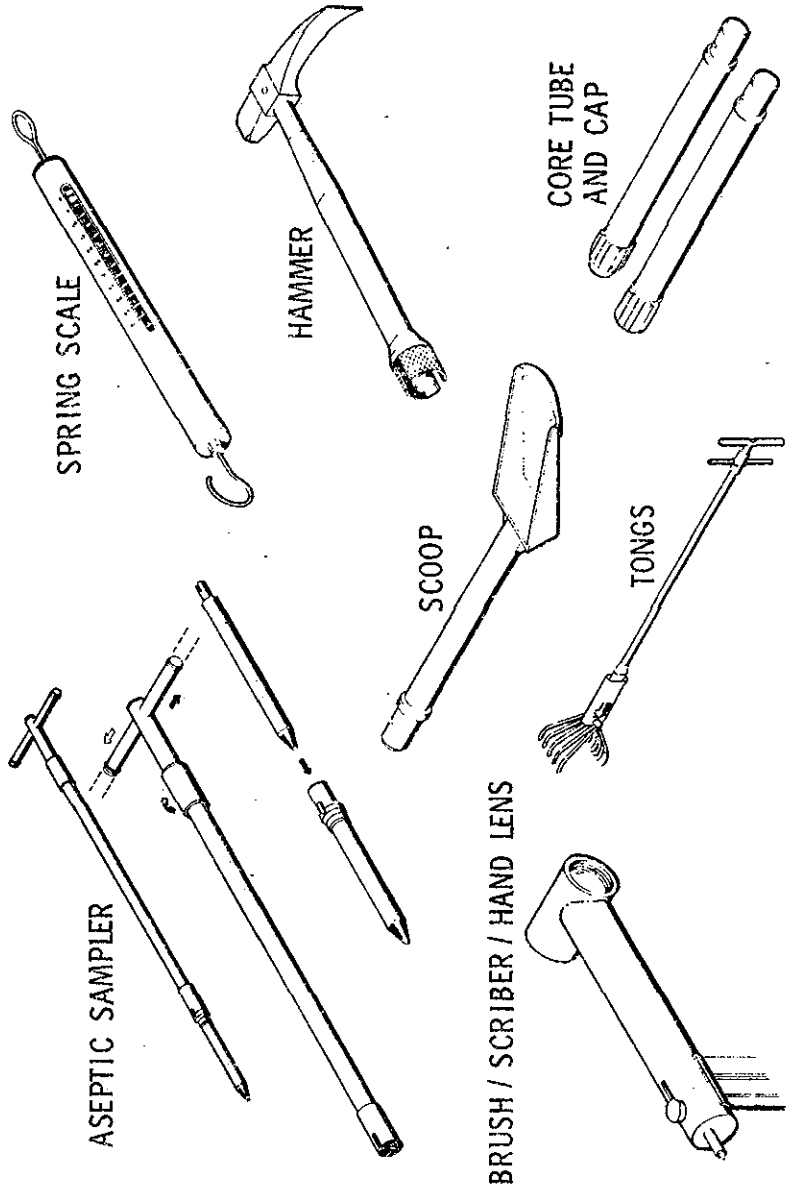

**GEOLOGIC SAMPLING TOOLS**

Tongs - The tongs are designed to allow the astronaut to retrieve small samples from the lunar surface while in a standing position. The tines are of such angles, length, and number to allow samples of from 3/8 up to 2-1/2-inch diameter to be picked up. This tool is 24 inches in overall length.

Brush/Scriber/Hand Lens - A composite tool

- (1) Brush - To clean samples prior to selection
- (2) Scriber - To scratch samples for selection and to mark for identification
- (3) Hand lens - Magnifying glass to facilitate sample selection

Spring Scale - To weigh two rock boxes containing lunar material samples, to maintain weight budget for return to Earth.

Instrument staff - The staff hold the Hasselblad camera. The staff breaks down into sections. The upper section telescopes to allow generation of a vertical stereoscopic base of one foot for photography. Positive stops are provided at the extreme of travel. A shaped hand grip aids in aiming and carrying. The bottom section is available in several lengths to suit the staff to astronauts of varying sizes. The device is fabricated from tubular aluminum.

Gnomon - This tool consists of a weighted staff suspended on a two-ring gimbal and supported by a tripod. The staff extends 12 inches above the gimbal and is painted with a gray scale. The gnomon is used as a photographic reference to indicate vertical sun angle and scale. The gnomon has a required accuracy of vertical indication of 20 minutes of arc. Magnetic damping is incorporated to reduce oscillations.

Color Chart - The color chart is painted with three primary colors and a gray scale. It is used as a calibration for lunar photography. The scale is mounted on the tool carrier but may easily be removed and returned to Earth for reference. The color chart is 6 inches in size.

Tool Carrier - The carrier is the stowage container for the tools during the lunar flight. After the landing the carrier serves as support for the astronaut when he kneels down, as a support for the sample bags and samples, and as a tripod base for the instrument staff. The carrier folds flat for stowage. For field use it opens into a triangular configuration. The carrier is constructed of formed sheet metal and approximates a truss structure. Six-inch legs extend from the carrier to elevate the carrying handle sufficiently to be easily grasped by the astronaut.

Field Sample Bags - Approximately 80 bags 4 inches by 5 inches are included in the ALHT for the packaging of samples. These bags are fabricated from Teflon FEP.

Collection Bag - This is a large bag (4 x 8 inches) attached to the astronaut's side of the tool carrier. Field sample bags are stowed in this bag after they have been filled. It can also be used for general storage or to hold items temporarily. (2 in each SRC).

### Apollo 12 Crew Menu

More than 70 items comprise the food selection list of freeze-dried rehydratable, wet-pack and spoon-bowl foods. Balanced meals for five days have been packed in man/day overwraps. Items similar to those in the daily menus have been packed in a snack pantry. The snack pantry permits the crew to locate easily a food item in a smorgasbord mode without having to "rob" a regular meal somewhere down deep in a storage box.

Water for drinking and rehydrating food is obtained from two sources in the command module--a dispenser for drinking water and a water spigot at the food preparation station supplying water at about 155 or 55° F. The potable water dispenser squirts water continuously as long as the trigger is held down, and the food preparation spigot dispenses water in one-ounce increments.

A continuous-feed hand water dispenser similar to the one in the command module is used aboard the lunar module for cold-water rehydration of food packets stowed aboard the LM.

After water has been injected into a food bag, it is kneaded for about three minutes. The bag neck is then cut off and the food squeezed into the crewman's mouth. After a meal, germicide pills attached to the outside of the food bags are placed in the bags to prevent fermentation and gas formation. The bags are then rolled and stowed in waste disposal compartments.

The day-by-day, meal-by-meal Apollo 12 Menu for Commander Conrad is on the following page as a typical five-day menu for each crewman.

TYPICAL CREW MENU IS THAT OF APOLLO 12 COMMANDER CONRAD:

APOLLO 12 (CONRAD - RED VELCRO)

NOTE: Supplementary items and meals to this menu are in the spacecraft's Pantry Stowage Section.

MEAL	Day 1* 5	Day 2	Day 3	Day 4	Day 5
A.	Peaches IMB Corn Flakes R Bacon Squares (8) IMB Orange Drink R Coffee w/Sugar R	Apricots IMB Sausage Patties R Scrambled Eggs RSB Grapefruit Drink R Coffee w/Sugar R	Pears IMB Corn Flakes R Bacon Squares (8) IMB Grape Drink R Coffee w/Sugar R	Canadian Bacon & Applesauce RSB Scrambled Eggs RSB Cinnamon Bread (4) DB Orange-G.F. Drink R Coffee w/Sugar R	
B.	Tuna Salad RSB Beef & Gravy WP Jellied Candy IMB Grape Punch R	Turkey & Gravy WP Cheese Crackers (4) DB Chocolate Pudding RSB Orange-G.F. Drink R	Frankfurters WP Applesauce RSB Chocolate Bar IMB P.A.-G.F. Drink R	Shrimp Cocktail R Ham & Potatoes WP Apricots IMB Chocolate Pudding RSB Orange Drink R	
C.	Cream of Chicken Soup RSB Chicken & Rice RSB Sugar Cookies (4) DB Butterscotch Pudding RSB P.A.-G.F. Drink R	Pork & Scalloped Potatoes RSB Bread Slice Sandwich Spread WP Jellied Candy IMB Cocoa R Orange Drink R	Salmon Salad RSB Chicken Stew RSB Butterscotch Pudding RSB Peaches IMB Grapefruit Drink R	Spaghetti w/Meat R Beef Stew RSB Banana Pudding RSB Cocoa R Grape Punch R	
TOTAL CALORIES					2215
* Day 1 consists of Meal B and C only.					
IMB = Intermediate Moisture Bite					
R = Rehydratable					
RSB = Rehydratable Spoon-Bowl					
WP = Wet Pack					
DB = Dry Bite					
TOTAL CALORIES					2346
TOTAL CALORIES					2328
TOTAL CALORIES					2106

### Personal Hygiene

Crew personal hygiene equipment aboard Apollo 12 includes body cleanliness items, the waste management system and one medical kit.

Packaged with the food are a toothbrush and a two-ounce tube of toothpaste for each crewman. Each man-meal package contains a 3.5-by-four-inch wet-wipe cleansing towel. Additionally, three packages of 12-by-12-inch dry towels are stowed beneath the command module pilot's couch. Each package contains seven towels. Also stowed under the command module pilot's couch are seven tissue dispensers containing 53 three-ply tissues each.

Solid body wastes are collected in Gemini-type plastic defecation bags which contain a germicide to prevent bacteria and gas formation. The bags are sealed after use and stowed in empty food containers for post-flight analysis.

Urine collection devices are provided for use while wearing either the pressure suit or the inflight coveralls. The urine is dumped overboard through the spacecraft urine dump valve in the CM and stored in the LM.

### Medical Kit

The 5x5x8-inch medical accessory kit is stowed in a compartment on the spacecraft right side wall beside the lunar module pilot couch. The medical kit contains three motion sickness injectors, three pain suppression injectors, one two-ounce bottle first aid ointment, two one-ounce bottle eye drops, three nasal sprays, two compress bandages, 12 adhesive bandages, one oral thermometer, and four spare crew biomedical harnesses. Pills in the medical kit are 60 antibiotic, 12 nausea, 12 stimulant, 18 pain killer, 60 decongestant, 24 diarrhea, 72 aspirin and 21 sleeping. Additionally, a small medical kit containing four stimulant, eight diarrhea, two sleeping and four pain killer pills, 12 aspirin, one bottle eye drops and two compress bandages is stowed in the lunar module flight data file compartment.

### Survival Gear

The survival kit is stowed in two rucksacks in the right-hand forward equipment bay above the lunar module pilot.

Contents of rucksack No. 1 are: two combination survival lights, one desalter kit, three pair sunglasses, one radio beacon, one spare radio beacon battery and spacecraft connector cable, one knife in sheath, three water containers, and two containers of Sun lotion.



Rucksack No. 2: one three-man life raft with CO<sub>2</sub> inflator, one sea anchor, two sea dye markers, three sun-bonnets, one mooring lanyard, three manlines, and two attach brackets.

The survival kit is designed to provide a 48-hour postlanding (water or land) survival capability for three crewmen between 40 degrees North and South latitudes.

#### Biomedical Inflight Monitoring

The Apollo 12 crew biomedical telemetry data received by the Manned Space Flight Network will be relayed for instantaneous display at Mission Control Center where heart rate and breathing rate data will be displayed on the flight surgeon's console. Heart rate and respiration rate average, range and deviation are computed and displayed on digital TV screens.

In addition, the instantaneous heart rate, real-time and delayed EKG and respiration are recorded on strip charts for each man.

Biomedical telemetry will be simultaneous from all crewmen while in the CSM, but selectable by a manual onboard switch in the LM.

Biomedical data observed by the flight surgeon and his team in the Life Support Systems Staff Support Room will be correlated with spacecraft and space suit environmental data displays.

Blood pressures are no longer telemetered as they were in the Mercury and Gemini programs. Oral temperature, however, can be measured onboard for diagnostic purposes and voiced down by the crew in case of inflight illness.

## Training

The crewmen of Apollo 12 have spent more than five hours of formal crew training for each hour of the lunar-orbit mission's eight-day duration. More than 1,000 hours of training were in Apollo 12 crew training syllabus over and above the normal preparations for the mission--technical briefings and reviews, pilot meetings and study. As Apollo 9 backup crew, they had already received more than 1,500 hours of training.

The Apollo 12 crewmen also took part in spacecraft manufacturing checkouts at the North American Rockwell plant in Downey, Calif., at Grumman Aircraft Engineering Corp., Bethpage, N.Y., and in prelaunch testing at NASA Kennedy Space Center. Taking part in factory and launch area testing has provided the crew with thorough operational knowledge of the complex vehicle.

Highlights of specialized Apollo 12 crew training topics are:

- \* Detailed series of briefings on spacecraft systems, operation and modifications.

- \* Saturn launch vehicle briefings on countdown, range safety, flight dynamics, failure modes and abort conditions. The launch vehicle briefings were updated periodically.

- \* Apollo Guidance and Navigation system briefings at the Massachusetts Institute of Technology Instrumentation Laboratory.

- \* Briefings and continuous training on mission photographic objectives and use of camera equipment.

- \* Extensive pilot participation in reviews of all flight procedures for normal as well as emergency situations.

- \* Stowage reviews and practice in training sessions in the spacecraft, mockups and command module simulators allowed the crewmen to evaluate spacecraft stowage of crew-associated equipment.

- \* More than 400 hours of training per man in command module and lunar module simulators at MSC and KSC, including closed-loop simulations with flight controllers in the Mission Control Center. Other Apollo simulators at various locations were used extensively for specialized crew training.

- \* Entry corridor deceleration profiles at lunar-return conditions in the MSC Flight Acceleration Facility manned centrifuge.

\* Lunar surface briefings and 1-g walk-throughs of lunar surface EVA operations covering lunar geology and micro-biology and deployment of experiments in the Apollo Lunar Surface Experiment Package (ALSEP). Training in lunar surface EVA included practice sessions with lunar surface sample gathering tools and return containers, cameras, the erectable S-band antenna and the modular equipment stowage assembly (MESA) housed in the LM descent stage.

\* Proficiency flights in the lunar landing training vehicle (LLTV) for the commander.

\* Zero-g aircraft flights using command module and lunar module mockups for EVA and pressure suit doffing/donning practice and training.

\* Underwater zero-g training in the MSC Water Immersion Facility using spacecraft mockups to further familiarize crew with all aspects of CSM-LM docking tunnel intravehicular transfer and EVA in pressurized suits.

\* Water egress training conducted in indoor tanks as well as in the Gulf of Mexico, included uprighting from the Stable II position (apex down) to the Stable I position (apex up), egress onto rafts donning Biological Isolation Garments (BIGs), decontamination procedures and helicopter pickup.

\* Launch pad egress training from mockups and from the actual spacecraft on the launch pad for possible emergencies such as fire, contaminants and power failures.

\* The training covered use of Apollo spacecraft fire suppression equipment in the cockpit.

\* Planetarium reviews at Morehead Planetarium, Chapel Hill, N.C., and at Griffith Planetarium, Los Angeles, Calif., of the celestial sphere with special emphasis on the 37 navigational stars used by the Apollo guidance computer.

Crew Biographies

NAME: Charles Conrad, Jr. (Commander, USN) Apollo 12 Commander  
NASA Astronaut

BIRTHPLACE AND DATE: Born on June 2, 1930, in Philadelphia, Pa.

PHYSICAL DESCRIPTION: Blond hair; blue eyes; height: 5 feet  
6 1/2 inches; weight: 138 pounds.

EDUCATION: Attended primary and secondary schools in Haverford,  
Pa., and New Lebanon, New York; received a Bachelor of  
Science degree in Aeronautical Engineering from Princeton  
University in 1953 and an Honorary Master of Arts degree  
from Princeton in 1966.

MARITAL STATUS: Married to the former Jane DuBose of Uvalde,  
Texas, where her parents, Mr. and Mrs. W. O. DuBose,  
now reside.

CHILDREN: Peter, December 24, 1954; Thomas, May 3, 1957;  
Andrew, April 30, 1959; Christopher, November 26, 1960.

OTHER ACTIVITIES: His hobbies include golf, swimming, and  
water skiing.

ORGANIZATIONS: Member of the American Institute of Aeronautics  
and Astronautics and the Society of Experimental Test  
Pilots.

SPECIAL HONORS: Awarded two Distinguished Flying Crosses, two  
NASA Exceptional Service Medals, and the Navy Astronaut  
Wings; recipient of Princeton's Distinguished Alumnus  
Award for 1965, the U. S. Jaycees' 10 Outstanding Young  
Men Award in 1965, and the American Astronautical Society  
Flight Achievement Award for 1966.

EXPERIENCE: Conrad entered the Navy following his graduation  
from Princeton University and became a naval aviator.  
He attended the Navy Test Pilot School at Patuxent River,  
Maryland, and upon completing that course of instruction  
was assigned as a project test pilot in the armaments  
test division there. He also served at Patuxent as a  
flight instructor and performance engineer at the Test  
Pilot School.

He has logged more than 4,000 hours flight time, with  
more than 3,000 hours in jet aircraft.

SALARY: \$1,554.08 per month in military pay and allowances.

CURRENT ASSIGNMENT: Commander Conrad was selected as an astronaut by NASA in September 1962. In August 1965, he served as pilot on the 8-day Gemini 5 flight. He and command pilot Gordon Cooper were launched into orbit on August 21 and proceeded to establish a new space endurance record of 190 hours and 56 minutes. The flight, which lasted 120 revolutions and covered a total distance of 3,312,993 statute miles, was terminated on August 29, 1965. It was also on this flight that the United States took over the lead in manhours in space.

On September 12, 1966, Conrad occupied the command pilot seat for the 3-day 44-revolution Gemini 11 mission. He executed orbital maneuvers to rendezvous and dock in less than one orbit with a previously launched Agena and controlled Gemini 11 through two periods of extravehicular activity performed by pilot Richard Gordon.

Other highlights of the flight included the retrieval of a nuclear emulsion experiment package during the first EVA; establishing a new world space altitude record of 850 statute miles; the successful completion of the first tethered station-keeping exercise, in which artificial gravity was produced; and the successful completion of the first fully automatic controlled reentry.

The flight was concluded on September 15, 1966, with the spacecraft landing in the Atlantic--2 1/2 miles from the prime recovery ship USS GUAM.

He served as backup commander for the Apollo 9 flight prior to his assignment as Apollo 12 commander.

Conrad has logged a total of 222 hours and 12 minutes of space flight in two missions.

NAME: Richard F. Gordon, Jr. (Commander, USN) Apollo 12  
Command Module Pilot, NASA Astronaut

BIRTHPLACE AND DATE: Born October 5, 1929, in Seattle,  
Washington. His mother, Mrs. Angela Gordon, resides  
in Seattle.

PHYSICAL DESCRIPTION: Brown hair; hazel eyes; height: 5 feet  
7 inches; weight: 150 pounds.

EDUCATION: Graduated from North Kitsap High School, Poulsbo,  
Washington; received a Bachelor of Science degree in  
Chemistry from the University of Washington in 1951.

MARITAL STATUS: Married to the former Barbara J. Field of  
Seattle, Washington. Her parents, Mr. and Mrs. Chester  
Field, reside in Freeland, Washington.

CHILDREN: Carleen, July 8, 1954; Richard, October 6, 1955;  
Lawrence, December 18, 1957; Thomas, March 25, 1959;  
James, April 26, 1960; Diane, April 23, 1961.

OTHER ACTIVITIES: He enjoys water skiing, sailing, and golf.

ORGANIZATIONS: Member of the Society of Experimental Test  
Pilots.

SPECIAL HONORS: Awarded two Distinguished Flying Crosses,  
the NASA Exceptional Service Medal, and the Navy  
Astronaut Wings.

EXPERIENCE: Gordon, a Navy Commander, received his wings as  
a naval aviator in 1953. He then attended All-Weather  
Flight School and jet transitional training and was  
subsequently assigned to an all-weather fighter  
squadron at the Naval Air Station at Jacksonville, Fla.

In 1957, he attended the Navy's Test Pilot School at  
Patuxent River, Maryland, and served as a flight test  
pilot until 1960. During this tour of duty, he did  
flight test work on the F8U Crusader, F11F Tigercat,  
FJ Fury, and A4D Skyhawk and was the first project  
test pilot for the F4H Phantom II.

He served with Fighter Squadron 121 at the Miramar,  
Calif., Naval Air Station as a flight instructor in  
the F4H and participated in the introduction of that  
aircraft to the Atlantic and Pacific fleets. He was  
also flight safety officer, assistant operations officer,  
and ground training officer for Fighter Squadron 96  
at Miramar.

Winner of the Bendix Trophy Race from Los Angeles to New York in May 1961, he established a new speed record of 869.74 miles per hour and a transcontinental speed record of 2 hours and 47 minutes.

He was also a student at the U. S. Naval Postgraduate School at Monterey, California.

He has logged more than 4,038 hours flying time--3,308 hours in jet aircraft.

SALARY: \$1,633.28 per month in military pay and allowance.

CURRENT ASSIGNMENT: Commander Gordon was one of the third group of astronauts named by NASA in October 1963. He has since served as backup pilot for the Gemini 8 flight.

On September 12, 1966, he served as pilot for the 3-day 44-revolution Gemini 11 mission--on which rendezvous with an Agena was achieved in less than one orbit. He executed docking maneuvers with the previously launched Agena and performed two periods of extravehicular activity which included attaching a tether to the Agena and retrieving a nuclear emulsion experiment package. Other highlights of the flight included the successful completion of the first tethered station-keeping exercise, the establishment of a new record setting altitude of 850 miles, and the first closed-loop controlled reentry.

The flight was concluded on September 15, 1966, with the spacecraft landing in the Atlantic--2 1/2 miles from the prime recovery ship, USS GUAM.

He served as Apollo 9 backup command module pilot prior to being named Apollo 12 command module pilot. Gordon has logged 71 hours 17 minutes of space flight--two hours and 44 minutes of which were in EVA.

NAME: Alan L. Bean (Commander, USN) Apollo 12 Lunar Module Pilot, NASA Astronaut

BIRTHPLACE AND DATE: Born in Wheeler, Texas, on March 15, 1932. His parents, Mr. and Mrs. Arnold H. Bean, reside in his hometown Fort Worth, Texas.

PHYSICAL DESCRIPTION: Brown hair; hazel eyes; height: 5 feet 9 1/2 inches; weight: 155 pounds.

EDUCATION: Graduated from Paschal High School in Fort Worth, Texas; received a Bachelor of Science degree in Aeronautical Engineering from the University of Texas in 1955.

MARITAL STATUS: Married to the former Sue Ragsdale of Dallas, Texas; her parents, Mr. and Mrs. Edward B. Ragsdale, are residents of that city.

CHILDREN: Clay A., December 18, 1955; Amy Sue, January 21, 1963.

OTHER ACTIVITIES: His hobbies are playing with his two children, surfing, painting, and handball; and he also enjoys swimming, diving, and gymnastics.

ORGANIZATIONS: Member of the Society of Experimental Test Pilots and Delta Kappa Epsilon.

EXPERIENCE: Bean, a Navy ROTC student at Texas, was commissioned upon graduation in 1955. Upon completing his flight training, he was assigned to Attack Squadron 44 at the Naval Air Station in Jacksonville, Florida, for four years. He then attended the Navy Test Pilot School at Patuxent River, Maryland. Upon graduation he was assigned as a test pilot at the Naval Air Test Center, Patuxent River, where he flew all types of naval aircraft (jet, propeller, and helicopter models) to evaluate their suitability for operational Navy use. Commander Bean participated in the initial trials of both the A5A and A4E jet attack airplanes. He attended the school of Aviation Safety at the University of Southern California and was next assigned to Attack Squadron 172 at Cecil Field, Florida, as an A-4 light jet attack pilot.

During his career, he has flown 27 aircraft and logged more than 3,775 hours flying time--including 3,212 hours in jet aircraft.



SALARY: \$1,071.08 per month in military pay and allowance.

CURRENT ASSIGNMENT: Commander Bean was one of the third group of astronauts selected by NASA in October 1963. He served as backup command pilot for the Gemini 10 mission and as the backup lunar module pilot for Apollo 9 prior to being named to the Apollo 12 crew as Lunar Module Pilot.

-more-

## LAUNCH COMPLEX 39

Launch Complex 39 facilities at the Kennedy Space Center were planned and built specifically for the Apollo Saturn V, the space vehicle being used in the United States' manned lunar exploration program.

Complex 39 introduced the mobile concept of launch operations in which the space vehicle is thoroughly checked out in an enclosed building before it is moved to the launch pad for final preparations. This affords greater protection from the elements and permits a high launch rate since pad time is minimal.

Saturn V stages are shipped to the Kennedy Space Center by ocean-going vessels and specially designed aircraft. Apollo spacecraft modules are transported by air and first taken to the Manned Spacecraft Operations Building in the Industrial Area south of Complex 39 for preliminary checkout, altitude chamber testing and assembly.

Apollo 12 is the sixth Saturn V/Apollo space vehicle to be launched from Complex 39's Pad A, one of two octagonal launch pads which are 3,000 feet across. The major components of Complex 39 include:

1. The Vehicle Assembly Building, heart of the complex, is where the 363-foot-tall space vehicle is assembled and tested. It contains 129.5 million cubic feet of space, covers eight acres, is 716 feet long and 518 feet wide. Its high bay area, 525 feet high, contains four assembly and checkout bays and its low bay area - 210 feet high, 442 feet wide and 274 feet long - contains eight stage-preparation and checkout cells. There are 141 lifting devices in the building, ranging from one-ton hoists to two 250-ton high lift bridge cranes.

2. The Launch Control Center, a four-story structure adjacent and to the south of the Vehicle Assembly Building is a radical departure from the dome-shaped, "hardened" blockhouse at older launch sites. The Launch Control Center is the electronic "brain" of Complex 39 and was used for checkout and test operations while Apollo 12 was being assembled inside the Vehicle Assembly Building high bay. Three of the four firing rooms contain identical sets of control and monitoring equipment so that launch of one vehicle and checkout of others may continue simultaneously. Each firing room is associated with a ground computer facility to provide data links with the launch vehicle on its mobile launcher at the pad or inside the Vehicle Assembly Building.

3. The Mobile Launcher, 445 feet tall and weighing 12 million pounds, is a transportable launch base and umbilical tower for the space vehicle.

4. The Transporters, used to move mobile launchers into the Vehicle Assembly Building and then - with their space vehicles - to the launch pad, weigh six million pounds and are among the largest tracked vehicles known. The Transporters - there are two - are 131 feet long and 114 feet wide. Powered by electric motors driven by two 2,750-horsepower diesel engines, the vehicles move on four double-tracked crawlers, each 10 feet high and 40 feet long. Maximum speed is about one-mile-per-hour loaded and two miles-per-hour unloaded. The three and one-half mile trip to Pad A with a mobile launcher and space vehicle takes approximately seven hours. Apollo 12 rollout to the pad occurred on September 8, 1969.

5. The Crawlerway is the roadway for the transporter and is 131 feet wide divided by a median strip. This is the approximate width of an eight-lane turnpike and the roadbed is designed to accommodate a combined weight of more than 18 million pounds.

6. The Mobile Service Structure is a 402-foot-tall, 9.8 million pound tower used to service the Apollo space vehicle at the pad. Moved into place about the Saturn V/Apollo space vehicle and its mobile launcher by a transporter, it contains five work platforms and provides 360-degree platform access to the vehicle being prepared for launch. It is removed to a parking area about 11 hours before launch.

7. A Water Deluge System will provide about a million gallons of industrial water for cooling and fire prevention during the launch of Apollo 12. The water is used to cool the mobile launcher, the flame trench and the flame deflector above which the mobile launcher is positioned.

8. The Flame Deflector is an "A"-shaped, 1.3 million pound structure moved into the flame trench beneath the launcher prior to launch. It is covered with a refractory material designed to withstand the launch environment. The flame trench itself is 58 feet wide and approximately six feet above mean sea level at the base.

9. The Pad Areas - A and B - are octagonal in shape and have center hardstands constructed of heavily reinforced concrete. The top of Pad A stands about 48 feet above sea level. Saturn V propellants - liquid oxygen, liquid hydrogen and RP-1, the latter a high grade kerosene - are stored in large tanks spaced near the pad perimeter and carried by pipelines from the tanks to the pad, up the mobile launcher and into the launch vehicle propellant tanks. Also located in the pad area are pneumatic, high pressure gas, electrical, and industrial water support facilities. Pad B, used for the launch of Apollo 10, is located 8,700 feet north of Pad A.

-more-

MISSION CONTROL CENTER

The Mission Control Center at the Manned Spacecraft Center, Houston, is the focal point for Apollo flight control activities. The center receives tracking and telemetry data from the Manned Space Flight Network which in turn is processed by the MCC Real-Time Computer Complex for display to flight controllers in the Mission Operations Control Room (MOCR) and adjacent staff support rooms.

Console positions in the two identical MOCRs in Mission Control Center fall into three basic operations groups: mission command and control, systems operations, and flight dynamics.

Positions in the command and control group are:

\* Mission Director -- responsible for overall mission conduct.

\* Flight Operations Director -- represents MSC management.

\* Flight Director -- responsible for operational decisions and actions in the MOCR.

\* Assistant Flight Director -- assists flight director and acts in his absence.

\* Flight Activities Officer -- develops and coordinates flight plan.

\* Department of Defense Representative -- coordinates and directs DOD mission support.

\* Network Controller -- responsible to FD for Manned Space Flight Network status and troubleshooting; MCC equipment operation.

\* Surgeon -- monitors crew medical condition and informs FD of any medical situation affecting mission.

\* Spacecraft Communicator (Capcom) -- serves as voice contact with flight crew.

\* Experiments Officer -- coordinates operation and control of onboard flight experiments.

\* Public Affairs Officer -- reports mission progress to public through commentary and relay of live air-to-ground transmissions.

Systems Operations Group:

\* Environmental, Electrical and Communications Engineer (EECOM) -- monitors and troubleshoots command/service module environmental, electrical, and sequential systems.

\* Guidance, Navigation and Control Engineer (GNC) -- monitors and troubleshoots CSM guidance, navigation, control, and propulsion systems.

\* LM Environmental and Electrical Engineer (TELCOM) -- LM counterpart to EECOM.

\* LM Guidance, Navigation and Control Engineer (Control)-- LM counterpart to GNC.

\* Booster Systems Engineer (three positions) -- responsible for monitoring launch vehicle performance and for sending function commands.

\* Apollo Communications Engineer (ACE) and Operations and Procedures Officer (O&P) -- share responsibility for monitoring and troubleshooting spacecraft and lunar surface communication systems and for coordinating MCC procedures with other NASA centers and the network.

Flight Dynamics Group:

\* Flight Dynamics Officer (FIDO) -- monitors powered flight events and plans spacecraft maneuvers.

\* Retrofire Officer (Retro) -- responsible for planning deorbit maneuvers in Earth orbit and entry calculations on lunar return trajectories.

\* Guidance Officer (Guido) -- responsible for monitoring and updating CSM and LM guidance systems and for monitoring systems performance during powered flight.

Each MOCR operations group has a staff support room on the same floor in which detailed monitoring and analysis is conducted. Other supporting MCC areas include the space-flight Meteorological Room, the Space Environment (radiation) Console, Spacecraft Planning and Analysis (SPAN) Room for detailed spacecraft performance analysis, Recovery Operations Control Room and the Apollo Lunar Surface Experiment Package Support Room.

Located on the first floor of the MCC are the communications, command, and telemetry system (CCATS) for processing incoming data from the tracking network, and the real-time computer complex (RTCC) which converts flight data into displays useable to MOCR flight controllers.

-more-

## MANNED SPACE FLIGHT NETWORK

The Manned Space Flight Network (MSFN) is a worldwide system that provides reliable, continuous, and instantaneous communications with the astronauts, launch vehicle, and spacecraft from liftoff to splashdown. The MSFN also will link between Earth and the Apollo experiments left on the lunar surface by the Apollo 12 crew.

The worldwide tracking network is maintained and operated by the NASA Goddard Space Flight Center (Greenbelt, Md.), under the direction of NASA's Office of Tracking and Data Acquisition. In the Manned Space Flight Network Operations Center (MSFNOC) at Goddard, the Network Director and his team of Operations Managers, with the assistance of a Network Support Team, keep the entire complex tuned for the mission support. Should Houston's mission control center be seriously impaired for an extended time, the Goddard Center becomes an emergency mission control center.

The MSFN employs 13 ground tracking stations equipped with 30- and 85- foot antennas, an instrumented tracking ship, and four instrumented aircraft. For Apollo 12, the network will be augmented by the 210-foot antenna systems at Goldstone, Calif. and at Parkes, Australia, (Australian Commonwealth Scientific and Industrial Research Organization).

NASA Communications Network (NASCOM). The tracking network is linked together by the NASA Communications Network. All information flows to and from MCC Houston and the Apollo spacecraft over this communications system.

The NASCOM consists of almost three million circuit miles of diversely routed communications channels. It uses satellites, submarine cables, land lines, microwave systems, and high frequency radio facilities for access links.

NASCOM control center is located at Goddard. Regional communication switching centers are located in London, Madrid, Canberra, Australia; Honolulu, and Guam.



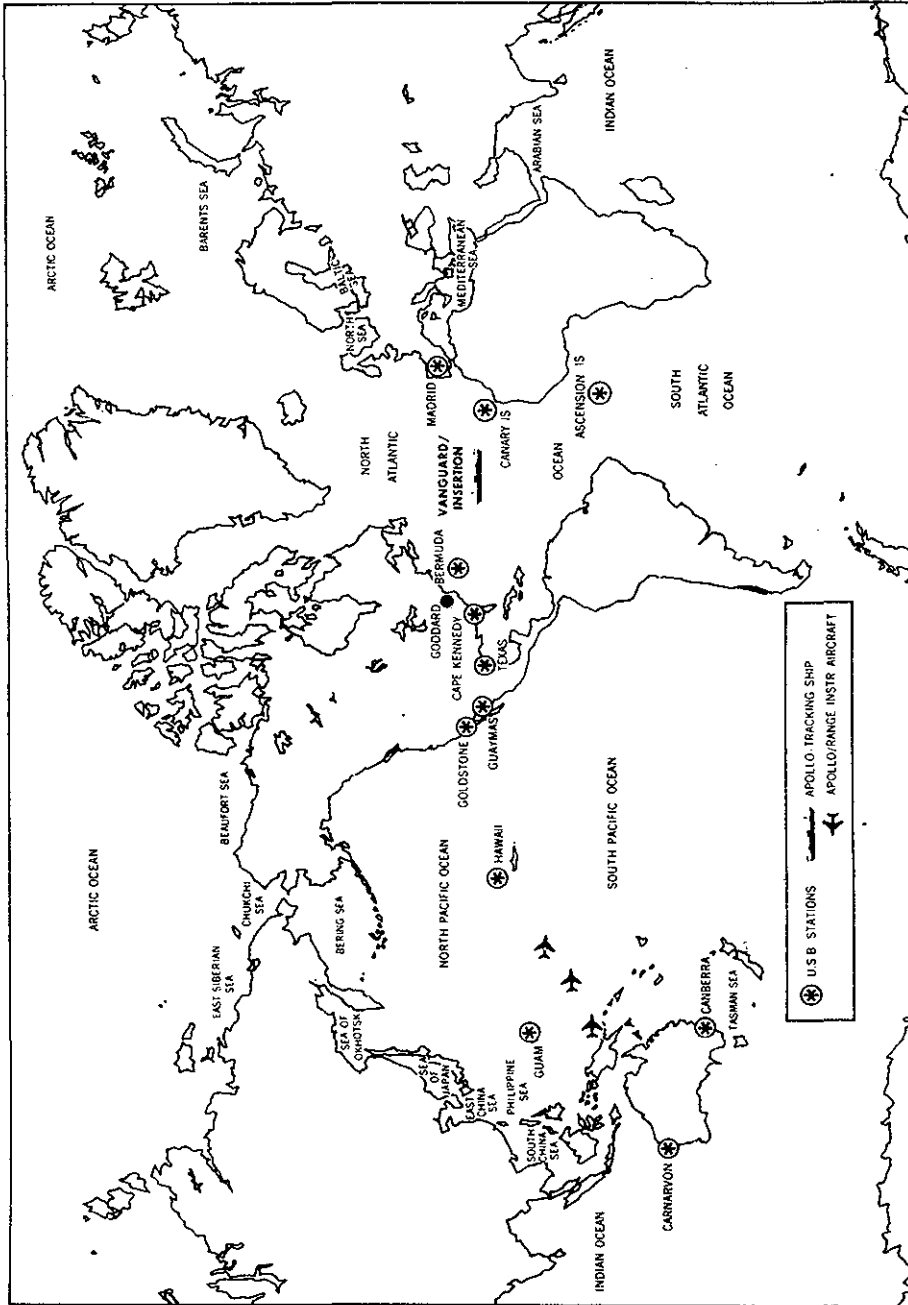

MANNED SPACE FLIGHT TRACKING NETWORK

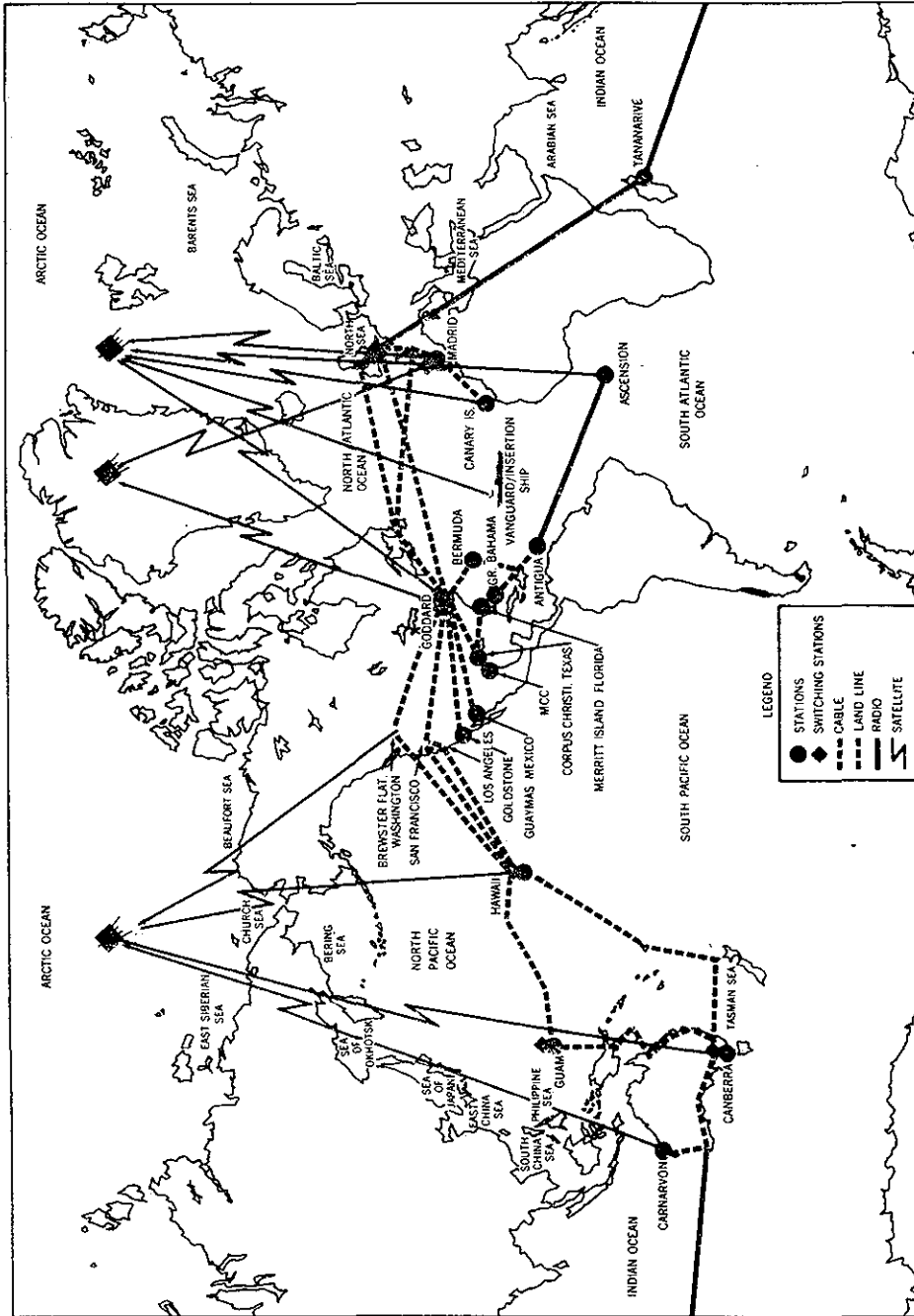

NASCOM

Three Intelsat communications satellites will be used for Apollo 12. One satellite over the Atlantic will link Goddard with stations at Madrid, Canary Islands, Ascension and the Vanguard tracking ship. Another Atlantic satellite will provide a direct link between Madrid and Goddard for TV signals received from the Apollo 12. The third satellite over the mid-Pacific will link the two Carnarvon and Canberra Australia and Hawaii with Goddard through a ground station at Brewster Flats, Wash.

At Goddard, NASCOM switching computers simultaneously send the voice signals directly to the Houston flight controllers and the tracking and telemetry data to computer processing complexes at Houston and Goddard. The Goddard Real Time Computing Complex verifies performance of the tracking network and uses the collected tracking data to drive displays in the Goddard Operations Control Center.

Establishing the Link -- The Merritt Island tracking station monitors prelaunch test, the terminal countdown, and the first minutes of launch.

An Apollo instrumentation ship (USNS VANGUARD) fills the gaps beyond the range of land tracking stations. For Apollo 12, this ship will be stationed in the Atlantic to cover the insertion into Earth orbit. Apollo instrumented aircraft provide communications support to the land tracking stations during translunar injection and reentry and cover a selected abort area in the event of "no-go" decision after insertion into Earth orbit.

Lunar Bound - Approximately one hour after the spacecraft has been injected into its translunar trajectory (some 10,000 miles from the Earth), three prime tracking stations spaced nearly equidistant around the Earth will take over tracking and communicating with Apollo.

The prime stations are located at Goldstone, Calif.; Madrid, Spain; and Canberra, Australia. Each station has a dual system for use when tracking the command module in lunar orbit and the lunar module in separate flight paths or at rest on the Moon.

The Return Trip -- To make an accurate reentry, data from the tracking stations are fed into the MCC computers to develop necessary information for the Apollo 12 crew.

Appropriate MSFN stations, including the aircraft in the Pacific, are on hand to provide support during the reentry.

Through the journey to the Moon and return, television will be received from the spacecraft at the three 85-foot antennas around the world. In addition, the 210-foot antennas in California and Australia will be used to augment the television coverage while the Apollo 12 is near and on the Moon. For black and white TV, scan converters at the stations permit immediate transmission of commercial quality TV via NASCOM to Houston, where it will be released to U.S. TV networks.

The black and white TV can be released simultaneously in Europe and the Far East through the MSFN stations in Spain and Australia.

If color TV is used, the signal will be converted to commercial quality at the MSC Houston.

#### Network Computers

At fraction-of-a-second intervals, the network's digital data processing systems, with NASA's Manned Spacecraft Center as the focal point, "talk" to each other or to the spacecraft. High-speed computers at the remote site (tracking ship included) relay commands or "up-link" data on such matters as control of cabin pressure, orbital guidance commands, or "go-no-go" indications to perform certain functions.

When information originates from Houston, the computers refer to their pre-programmed information for validity before transmitting the required data to the spacecraft.

Such "up-link" information is communicated at a rate of about 1,200 bits-per-second. Communication between remote ground sites, via high-speed communications links, occurs at about the same rate. Houston reads information, two channels at a time, from these ground sites at 2,400 bits-per-second.

The computer systems perform many other functions, including:

Assuring the quality of the transmission lines by continually exercising data paths;

Verifying accuracy of the messages.

Constantly updating the flight status.

For "down-link" data, sensors built into the spacecraft continually sample cabin temperature, pressure, physical information on the astronauts such as heartbeat and respiration. These data are transmitted to the ground stations at 51.2 kilobits (12,800 decimal digits) per second.

At MCC the computers:

Detect and select changes or deviations, compare with their stored programs, and indicate the problem areas or pertinent data to the flight controllers;

Provide displays to mission personnel;

Assemble output data in proper formats;

Log data on magnetic tape for reply for the flight controllers.

#### The Apollo Ship Vanguard

The USNS Vanguard will perform tracking, telemetry, and communication functions for the launch phase and Earth orbit insertion. Vanguard will be stationed about 1,000 miles southeast of Bermuda (28 degrees N., 49 degrees W.).

#### Apollo Range Instrumentation Aircraft (ARIA)

During Apollo 12 TLI maneuver, two ARIA will record telemetry data from Apollo and relay voice communication between the astronauts and the Mission Control Center at Houston. The ARIA will be located between Australia and Hawaii.

For reentry, two ARIA will be deployed to the landing area to relay communications between Apollo and Mission Control at Houston and provide position information on the spacecraft after the blackout phase of reentry has passed.

The total ARIA fleet for Apollo missions consists of four EC-135A (Boeing 707) jets with 7-foot parabolic antennas installed in the nose section.

## Lunar Receiving Laboratory (LRL)

The final phase of the back contamination program is completed in the MSC Lunar Receiving Laboratory. The crew and spacecraft are quarantined for a minimum of 21 days after completion of lunar EVA operations and are released based upon the completion of prescribed test requirements and results. The lunar sample will be quarantined for a period of 50 to 80 days depending upon results of extensive biological tests.

The LRL serves four basic purposes:

- . Quarantine of crew and spacecraft, the containment of lunar and lunar-exposed materials, and quarantine testing to search for adverse effects of lunar material upon terrestrial life.
- . The preservation and protection of the lunar samples.
- . The performance of time critical investigations.
- . The preliminary examination of returned samples to assist in an intelligent distribution of samples to principal investigators.

The LRL has the only vacuum system in the world with space gloves operated by a man leading directly into a vacuum chamber at pressures of  $10^{-7}$  torr. (mm Hg) (or one 10 billionth of an atmosphere). It has a low level counting facility, whose background count is an order of magnitude better than other known counters. Additionally, it is a facility that can handle a large variety of biological specimens inside Class III biological cabinets designed to contain extremely hazardous pathogenic material.

The LRL covers 83,000 square feet of floor space and includes a Crew Reception Area (CRA), Vacuum Laboratory, Sample Laboratories (Physical and Bio-Science) and an administrative and support area. Special building systems are employed to maintain air flow into sample handling areas and the CRA, to sterilize liquid waste, and to incinerate contaminated air from the primary containment systems.

The biomedical laboratories provide for quarantine tests to determine the effect of lunar samples on terrestrial life. These tests are designed to provide data upon which to base the decision to release lunar material from quarantine.

Among the tests:

a. Germ-free mice will be exposed to lunar material and observed continuously for 21 days for any abnormal changes. Periodically, groups will be sacrificed for pathologic observation.

b. Lunar material will be applied to 12 different culture media and maintained under several environmental conditions. The media will be observed for bacterial or fungal growth. Detailed inventories of the microbial flora of the spacecraft and crew have been maintained so that any living material found in the sample testing can be compared against this list of potential contaminants taken to the Moon by the crew or spacecraft.

c. Six types of human and animal tissue culture cell lines will be maintained in the laboratory and together with embryonated eggs are exposed to the lunar material. Based on cellular and/or other changes, the presence of viral material can be established so that special tests can be conducted to identify and isolate the type of virus present.

d. Thirty-three species of plants and seedlings will be exposed to lunar material. Seed germination, growth of plant cells or the health of seedlings are then observed, and histological, microbiological and biochemical techniques are used to determine the cause of any suspected abnormality.

e. A number of lower animals will be exposed to lunar material, including fish, birds, oysters, shrimp, cockroaches, houseflies, planaria, paramecia and euglena. If abnormalities are noted, further tests will be conducted to determine if the condition is transmissible from one group to another.

The crew reception area provides biological containment for the flight crew and 12 support personnel. The nominal occupancy is about 14 days but the facility is designed and equipped to operate for considerably longer.

### Sterilization and Release of the Spacecraft

Postflight testing and inspection of the spacecraft is presently limited to investigation of anomalies which happened during the flight. Generally, this entails some specific testing of the spacecraft and removal of certain components of systems for further analysis. The timing of postflight testing is important so that corrective action may be taken for subsequent flights.

The schedule calls for the spacecraft to be returned to port where a team will deactivate pyrotechnics, and flush and drain fluid systems (except water). This operation will be confined to the exterior of the spacecraft. The spacecraft will then be flown to the LRL and placed in a special room for storage, sterilization, and postflight checkout.

The Interagency Committee on Back Contamination (ICBC) functions to assist NASA in the program to prevent contamination of the Earth from lunar materials. The ICBC met Oct. 30 in Atlanta to review the Apollo 12 contamination control procedures.



LUNAR RECEIVING LABORATORY TENTATIVE SCHEDULE

- Nov. 19    Activate secondary barrier; support people enter Crew Reception Area and Central Status Station manned; LRL on mission status.
- Nov. 24    Command module landing, recovery.
- Nov. 25    First sample return container (SRC) arrives.
- Nov. 26    First SRC opened in vacuum lab, second SRC arrives; film, tapes, LM tape recorder begin decontamination; second SRC opened in Bioprep lab.
- Nov. 27    First sample to Radiation Counting Laboratory.
- Nov. 29    Core tube moves from vacuum lab to Physical-Chemical Lab.
- Nov. 30    MQF arrives; contingency sample goes to Physical-Chemical Lab; rock description begun in vacuum lab.
- Dec. 1    Biosample rocks move from vacuum lab to Bioprep Lab; core tube prepared for biosample.
- Dec. 3    Spacecraft arrives.
- Dec. 4    Biosample compounded, thin-section chips sterilized out to Thin-Section Lab, remaining samples from Bioprep Lab canned.
- Dec. 6    Thin-section preparation complete, biosample prep complete, transfer to Physical-Chemical Lab complete, Bioprep Lab cleanup complete.
- Dec. 8    Biological protocols, Physical-Chemical Lab rock description begin.
- Dec. 10    Crew released from CRA.
- Dec. 12    Spacecraft released.
- Dec. 20    Rock description complete, Preliminary Examination Team data from Radiation Counting Lab and Gas Analysis Lab complete.
- Dec. 22    PET data write-up and sample catalog preparation begin.

Dec. 24 Data summary for Lunar Sample Analysis Planning Team (LSAPT) complete.

Dec. 26 LSAPT arrives.

Dec. 27 LSAPT briefed on PET data, sample packaging begins.

Dec. 31 Sample distribution plan complete, first batch monopole samples canned.

Jan. 2 Monopole experiment begins.

Jan. 5 Apollo 11 principal investigator conference begins.

Jan. 7 Sample distribution plan approved, sample release, sample catalog complete.

Jan. 8 Initial release of Apollo 12 samples.

Jan. 12 Spacecraft equipment released.

Jan. 16 Apollo 12 mission critique.

## CONTAMINATION CONTROL PROGRAM

In 1966 an Interagency Committee on Back Contamination (ICBC) was established to assist NASA in developing a program to prevent contamination of the Earth from lunar materials following manned lunar exploration and to review and approve plans and procedures to prevent back contamination. Committee membership includes representatives from Public Health Service, Department of Agriculture, Department of the Interior, NASA, and the National Academy of Sciences.

The Apollo Back Contamination Program can be divided into three phases. The first phase covers procedures which are followed by the crew while in flight to reduce and, if possible, eliminate the return of lunar surface contaminations in the command module.

The second phase includes recovery, isolation, and transport of the crew, spacecraft, and lunar samples to the Manned Spacecraft Center. The third phase encompasses quarantine operations and preliminary sample analysis in the Lunar Receiving Laboratory.

A primary step in preventing back contamination is careful attention to spacecraft cleanliness following lunar surface operations. This includes use of special cleaning equipment, stowage provisions for lunar-exposed equipment, and crew procedures for proper "housekeeping."

Prior to reentering the LM after lunar surface exploration, the crewmen brush lunar surface dust or dirt from the space suit using the suit gloves. They will scrape their overboots on the LM footpad and while ascending the LM ladder, dislodge any clinging particles by a kicking action.

After entering and pressurizing the LM cabin, the crew doff their portable life support system, oxygen purge system, lunar boots, EVA gloves, etc.

Following LM rendezvous and docking with the CM, the CM tunnel will be pressurized and checks made to insure that an adequate pressurized seal has been made. During the period, the LM, space suits, and lunar surface equipment will be vacuumed.

The lunar module cabin atmosphere will be circulated through the environmental control system suit circuit lithium hydroxide (LiOH) canister to filter particles from the atmosphere. A minimum of five hours weightless operation and filtering will essentially eliminate the original airborne particles.

The CM pilot will transfer lunar surface equipment stowage bags into the LM one at a time. The equipment transferred will be bagged before being transferred. The only equipment which will not be bagged at this time are the crewmen's space suits and flight logs.

Command Module Operations - Through the use of operational and housekeeping procedures the command module cabin will be purged of lunar surface and/or other particulate contamination prior to Earth reentry. These procedures start while the LM is docked with the CM and continue through reentry into the Earth's atmosphere.

During subsequent lunar orbital flight and the trans-earth phase, the command module atmosphere will be continually filtered through the environmental control system lithium hydroxide canister. This will remove essentially all airborne dust particles. After about 96 hours operation essentially none of the original contaminants will remain.

#### Lunar Mission Recovery Operations

Following landing and the attachment of the flotation collar to the command module, the swimmer in a biological isolation garment (BIG) will open the spacecraft hatch, pass three BIGs into the spacecraft, and close the hatch.

The crew will don the BIG's and then egress into a life raft. The hatch will be closed immediately after egress. Tests have shown that the crew can don their BIG's in less than 5 minutes under ideal sea conditions. The spacecraft and crew will be decontaminated by the swimmer using a liquid agent.

Crew retrieval will be accomplished by helicopter to the carrier and subsequent crew transfer to the Mobile Quarantine Facility. The spacecraft will be retrieved by the aircraft carrier and isolated.

SCHEDULE FOR TRANSPORT OF SAMPLES, SPACECRAFT AND CREW

Samples

The first Apollo 12 lunar sample return container will be flown by carrier on-board delivery (COD) aircraft from the deck of the USS Hornet to Samoa, from where it will be flown by USAF C-141 to Ellington AFB about 21 hours after spacecraft touchdown.

The second sample container will leave the Hornet by COD aircraft about 13 hours after splashdown, transfer at Samoa to an ARIA aircraft, and after a refueling stop in Hawaii, arrive at Ellington AFB about 30 hours after spacecraft splashdown. Both sample return flights will include medical supplies, spacecraft onboard film and other equipment. The shipments will be moved by auto to the Lunar Receiving Laboratory.

Spacecraft

The spacecraft is scheduled to be brought aboard the Hornet about two hours after crew recovery. About four days, 19 hours after recovery the ship is expected to arrive in Hawaii. The spacecraft will be deactivated in Hawaii between 115 and 166 hours after recovery. At 166 hours it is scheduled to be loaded on a C-133B for return to Ellington AFB. Estimated time of arrival at the LRL is on Dec. 2, 198 hours after recovery.

Crew

The flight crew is expected to enter the Mobile Quarantine Facility (MQF) on the recovery ship about 90 minutes after splashdown. The ship is expected to arrive in Hawaii at recovery plus 115 hours and the Mobile Quarantine Facility will be transferred to a C-141 aircraft at Pearl Harbor at recovery plus 117 hours. The aircraft will land at Ellington AFB at recovery plus 123 hours and the MQF will arrive at the LRL about two hours later Nov. 29.

APOLLO PROGRAM MANAGEMENT

The Apollo Program is the responsibility of the Office of Manned Space Flight (OMSF), National Aeronautics and Space Administration, Washington, D. C. Dr. George E. Mueller is Associate Administrator for Manned Space Flight.

NASA Manned Spacecraft Center (MSC), Houston, is responsible for development of the Apollo spacecraft, flight crew training, and flight control. Dr. Robert R. Gilruth is Center Director.

NASA Marshall Space Flight Center (MSFC), Huntsville, Ala., is responsible for development of the Saturn launch vehicles. Dr. Wernher von Braun is Center Director

NASA John F. Kennedy Space Center (KSC), Fla., is responsible for Apollo/Saturn launch operations. Dr. Kurt H. Debus is Center Director.

The NASA Office of Tracking and Data Acquisition (OTDA) directs the program of tracking and data flow on Apollo. Gerald M. Truszynski is Associate Administrator for Tracking and Data Acquisition.

NASA Goddard Space Flight Center (GSFC), Greenbelt, Md., manages the Manned Space Flight Network and Communications Network. Dr. John F. Clark is Center Director.

The Department of Defense is supporting NASA in Apollo 12 during launch, tracking and recovery operations. The Air Force Eastern Test Range is responsible for range activities during launch and down-range tracking. Recovery operations include the use of recovery ships and Navy and Air Force aircraft.

Apollo/Saturn Officials

NASA Headquarters

Dr. Rocco A. Petrone	Apollo Program Director, OMSF
Capt. Chester M. Lee, (USN, Ret.)	Apollo Mission Director, OMSF
Col. Thomas H. McMullen (USAF)	Assistant Mission Director, OMSF
Maj. Gen. James W. Humphreys, Jr.	Director of Space Medicine, OMSF
Norman Pozinsky	Director, Network Support Implementation Div., OTDA

Manned Spacecraft Center

Col. James A. McDivitt, (USAF)	Manager, Apollo Spacecraft Program
Kenneth S. Kleinknecht	Manager, Command and Service Modules
Owen G. Morris	Manager, Lunar Module (Acting)
Donald K. Slayton	Director of Flight Crew Operations
Christopher C. Kraft, Jr.	Director of Flight Operations
Gerald Griffin	Flight Director
Glynn S. Lunney	Flight Director
Clifford E. Charlesworth	Flight Director
M. P. Frank	Flight Director
Charles A. Berry	Director of Medical Research and Operations

Marshall Space Flight Center

Lee B. James	Director, Program Management
Dr. F. A. Speer	Manager, Mission Operations Office
Roy E. Godfrey	Manager, Saturn Program Office
Matthew W. Urlaub	Manager, S-IC Stage, Saturn Program Office
W. F. LaHatte	Manager, S-II Stage, Saturn Program Office
James C. McCulloch	Manager, S-IVB Stage, Saturn Program Office
Frederich Duerr	Manager, Instrument Unit, Saturn Program Office
William D. Brown	Manager, Engine Program Office

Kennedy Space Center

Walter J. Kapryan	Director, Launch Operations
Edward R. Mathews	Manager, Apollo Program Office
Dr. Hans F. Gruene	Director, Launch Vehicle Operations
John J. Williams	Director, Spacecraft Operations
Paul C. Donnelly	Launch Operations Manager

Goddard Space Flight Center

Ozro M. Covington	Director of Manned Flight Support
William P. Varson	Chief, Manned Flight Planning & Analysis Division
H. William Wood	Chief, Manned Flight Operations Division
Tecwyn Roberts	Chief, Manned Flight Engineering Division
L. R. Stelter	Chief, NASA Communications Div.



Department of Defense

Maj. Gen. David M. Jones, (USAF)	DOD Manager of Manned Space Flight Support Operations, Commander of USAF Eastern Test Range
Rear Adm. Donald C. Davis, (USN)	Commander of Combined Task Force 130, Pacific Recovery Area
Rear Adm. Philip S. McManus, (USN)	Commander of Combined Task Force 140, Atlantic Recovery Area
Col. Royce G. Olson, (USAF)	Director of DOD Manned Space Flight Office
Brig. Gen. Allison C. Brooks, (USAF)	Commander Aerospace Rescue and Recovery Service

-more-

Major Apollo/Saturn V Contractors

<u>Contractor</u>	<u>Item</u>
Bellcomm Washington, D. C.	Apollo Systems Engineering
The Boeing Co. Washington, D. C.	Technical Integration and Evaluation
General Electric-Apollo Systems Daytona Beach, Fla	Apollo Checkout, and Quality and Reliability
North American Rockwell Corp. Space Div., Downey, Calif.	Command and Service Modules
Grumman Aircraft Engineering Corp., Bethpage, N.Y.	Lunar Module
Massachusetts Institute of Technology, Cambridge, Mass.	Guidance & Navigation (Technical Management)
General Motors Corp., AC Electronics Div., Milwaukee, Wis.	Guidance & Navigation (Manufacturing)
TRW Inc. Systems Group Redondo Beach, Calif.	Trajectory Analysis LM Descent Engine LM Abort Guidance System
Avco Corp., Space Systems Div., Lowell, Mass.	Heat Shield Ablative Material
North American Rockwell Corp. Rocketdyne Div. Canoga Park, Calif.	J-2 Engines, F-1 Engines
The Boeing Co. New Orleans,	First Stage (SIC) of Saturn V Launch Vehicles, Saturn V Systems Engineering and Inte- gration, Ground Support Equip- ment
North American Rockwell Corp. Space Div. Seal Beach, Calif.	Development and Production of Saturn V Second Stage (S-II)
McDonnell Douglas Astronautics Co., Huntington Beach, Calif.	Development and Production of Saturn V Third Stage (S-IVB)

International Business Machines  
Federal Systems Div.  
Huntsville, Ala.

Bendix Corp.  
Navigation and Control Div.  
Teterboro, N.J.

Federal Electric Corp.

Bendix Field Engineering Corp.

Catalytic-Dow

Hamilton Standard Division  
United Aircraft Corp.  
Windsor Locks, Conn.

ILC Industries  
Dover, Del.

Radio Corp. of America  
Van Nuys, Calif.

Sanders Associates  
Nashua, N.H.

Brown Engineering  
Huntsville, Ala.

Reynolds, Smith and Hill  
Jacksonville, Fla.

Ingalls Iron Works  
Birmingham, Ala.

Smith/Ernst (Joint Venture)  
Tampa, Fla.  
Washington, D. C.

Power Shovel, Inc.  
Marion, Ohio

Hayes International  
Birmingham, Ala.

Bendix Aerospace Systems  
Ann Arbor, Mich.

Aerojet-Gen. Corp.  
El Monte, Calif.

Instrument Unit

Guidance Components for Instru-  
ment Unit (Including ST-124M  
Stabilized Platform)

Communications and Instru-  
mentation Support, KSC

Launch Operations/Complex  
Support, KSC

Facilities Engineering and  
Modifications, KSC

Portable Life Support System;  
LM ECS

Space Suits

110A Computer - Saturn Checkout

Operational Display Systems  
Saturn

Discrete Controls

Engineering Design of Mobile  
Launchers

Mobile Launchers (ML)  
(Structural Work)

Electrical Mechanical Portion  
of MLs

Transporter

Mobile Launcher Service Arms

Apollo Lunar Surface Experi-  
ments Package (ALSEP)

Service Propulsion System Engine