

DEPARTMENT OF THE NAVY
ATLANTIC DIVISION, NAVAL FACILITIES ENGINEERING COMMAND
NAVAL STATION, NORFOLK, VIRGINIA

BB

SEP 22 1977

NOTICE:

RECEIVED
CAROLINAS BRANCH ADD
AUG 26 1977
KT

N62470-76-B-6799

NAVFAC
SPECIFICATION
NO. 05-76-6799

at the office of the
Officer in Charge of Construction
Jacksonville, North Carolina Area
Building 1005
Marine Corps Base
Camp Lejeune, North Carolina 28542

Appropriation: O&MMC

BA 190
RR 97
653
654

REPLACE FOUR WATER WELLS
AT THE
MARINE CORPS BASE, CAMP LEJEUNE, NORTH CAROLINA

(HQMC 7302)

DESIGN BY: Atlantic Division
Naval Facilities Engineering Command
Naval Station, Norfolk, Virginia 23511

SPECIFICATION PREPARED BY:

Architect: C. M. Tennefoss, R.A.
Civil-Structural: C. R. Rose, P.E.
Electrical: W. T. McGraw
Approved by: F. M. Dennis, P.E.
Date: 8 March 1977

CONTENTS

SECTION 00101. Bidding Information

DIVISION

1. General Requirements

SECTION

01011. General Paragraphs

01012. Additional General Paragraphs

2. Detail Requirements

SECTION

02110. Demolition

02201. Earthwork

02501. Storm Drainage Systems

02608. Crushed Stone Pavement

02822. Establishing Vegetation

03301. Cast-In-Place Concrete

13601. Prefabricated Metal Buildings

15011. General Requirements, Mechanical

15201. Wells

15221. Pumping Equipment

15272. Water Distribution

15840. Ductwork

16300. Electrical Distribution, Exterior

16402. Interior Electrical Systems

SECTION 00101

BIDDING INFORMATION

1. CONTENTS: This Invitation for Bids, IFB No. N62470-76-B-6799, consists of the following documents:

(a) Bid Instruction Documents

- (i) Invitation for Bids (Standard Form 20, Jan 1961 Ed.)
- (ii) Bidding Information
- (iii) Instructions to Bidders, dated January 1975.

(b) Bid Submittal Documents

- (i) Bid Form (Standard Form 21, Dec 1965 Ed.)
- (ii) Representations and Certifications (Standard Form 19-B, Oct 1969 Ed.).
- (iii) Bid Guaranty.
- (iv) Clean Air and Water Certification.

(c) Contract Documents

- (i) Construction Contract (Standard Form 23, Jan 1961 Ed.)
- (ii) Performance Bond (Standard Form 25, Jun 1967 Ed.)
- (iii) Payment Bond (Standard Form 25A, Jun 1964 Ed.)
- (iv) Labor Standards Provisions, dated November 1975.
- (v) General Provisions dated January 1977.
- (vi) NAVFAC Specification No. 05-76-6799.
- (vii) Wage Determination Decision
- (viii) Drawings identified in Section 01011, Division 1 of the Specifications.

2. BIDS:

(a) INSTRUCTION TO BIDDERS: Instructions to Bidders, and Invitation for Bids, Standard Form 20, January 1961 edition, shall be observed in the preparation of bids. Bidders shall affix their names and return addresses in the upper left corner of bid envelope. Envelopes containing bids must be sealed.

(b) BID GUARANTY will be required as stipulated in the Instructions to Bidders.

(c) ITEMS OF BIDS. Bids shall be submitted, in duplicate, on Standard Form 21, Bid Form, and shall be accompanied by Standard Form 19B, Representations and Certifications, Bid Guaranty, and Clean Air and Water Certification, all in accordance with the Bid Instruction Documents listed in paragraph 1(a) hereinbefore upon the following item(s):

Base Bid: Price for the entire work, complete in accordance with the drawings and specifications.

(d) TELEGRAPHIC MODIFICATIONS OF BIDS in accordance with the Instructions to Bidders may be made. Two signed copies of the telegram in a sealed envelope marked "Copies of telegraphic modification of bid for Replace Water Wells, Specification No. 05-76-6799" should be forwarded immediately to the office to which the written bids were submitted.

(e) TELEGRAPHIC MODIFICATIONS OR WITHDRAWAL OF BIDS. Telegraphic modifications or withdrawal of bids will be considered as specified herein. TELEPHONIC RECEIPT OF TELEGRAPHIC MODIFICATIONS OR WITHDRAWAL OF BIDS WILL NOT QUALIFY THE TELEGRAM AS TIMELY. The telegram must be received at the place specified for receipt of bids prior to the exact time set for receipt of bids.

(f) HAND DELIVERED BIDS: All hand delivered bids must be deposited in the bid box at office of the Officer in Charge of Construction, Jacksonville, North Carolina Area, Building 1005, Marine Corps Base, Camp Lejeune, North Carolina 28542 prior to the time and date set for bid opening. Any bids submitted by hand after the time set for receipt will not be accepted.

3. PRE-BID SITE VISITATION: To inspect the site of the work prior to bid opening, prior appointment must be made with the Assistant Officer in Charge of Construction, Jacksonville, North Carolina Area, telephone 451-2581, Area Code 919. Bidders are urged and expected to inspect the site where services are to be performed and to satisfy themselves as to all general and local conditions that may affect the cost of performance of the contract to the extent such information is reasonably obtainable. In no event will a failure to inspect the site constitute grounds for withdrawal of a bid after opening or for a claim after award of the contract.

4. CONTROLLED MATERIALS DATA: The Contracting Officer will issue a DO-C2 priority rating for procurement of critical materials. See GENERAL PROVISION 48, "PRIORITIES, ALLOCATIONS AND ALLOTMENTS".

5. INQUIRIES: All questions concerning the bidding or any other phase of the plans and specifications occurring prior to bid opening shall be presented to the Officer in Charge of Construction, Jacksonville, North Carolina Area, telephone 451-2581, Area code 919. Questions requiring interpretation of drawings and specifications must be submitted at least 10 days before bid opening. Interpretations or modifications to specifications made as a result of questions will be made by amendment only, and unless so done, all bidders should base their bids on the plans and specifications as issued.

6. AVAILABILITY OF SPECIFICATIONS, STANDARDS AND DESCRIPTIONS (1974 APR): Specifications, standards and descriptions cited in this solicitation are available as indicated below:

(a) Unclassified Federal, Military and Other Specifications and Standards (Excluding Commercial), and Data Item Descriptions. Submit request on DD Form 1425 (Specifications and Standards Requisition) to:

Commanding Officer
U. S. Naval Publications and Forms Center
5801 Tabor Avenue -- Philadelphia, PA 19120

The Department of Defense Index of Specifications and Standards (DODISS) may be purchased from the Superintendent of Documents, U. S. Government Printing Office, Washington, D.C., 20402. When requesting a specification or standard, the request shall indicate the title, number, date and any applicable amendment thereto by number and date. When requesting a data item description, the request shall cite the solicitation. When DD Form 1425 is not available, the request may be submitted in letter form, giving the same information as listed above, and the solicitation or contract number involved. Such request may also be made to the activity by telegram or telephone (area code 215, 697-3321) in case of urgency.

(b) Commercial Specifications, Standards and Descriptions: These specifications, standards and descriptions are not available from Government sources. They may be obtained from the publishers.

(c) Availability for Examination of Specifications, Standards, Plans, Drawings, and Other Pertinent Documents: The specifications, standards, plans, drawings, and other pertinent documents cited in this solicitation may be examined at the following location:

Office of the Officer in Charge of Construction
Jacksonville, North Carolina Area
Building 1005
Marine Corps Base
Camp Lejeune, North Carolina 28542

7. CLEAN AIR AND WATER CERTIFICATION (1975 OCT):

Applicable if the bid or offer exceeds \$100,000, or the Contracting Officer has determined that orders under an indefinite quantity contract in any year will exceed \$100,000, or a facility to be used has been the subject of a conviction under the Clean Air Act (42 U.S.C. 1857c-8(c)(1)) or the Federal Water Pollution Control Act (33 U.S.C. 1319(c)) and is listed by EPA, or is not otherwise exempt.

The bidder or offeror certifies as follows:

- (i) any facility to be utilized in the performance of this proposed contract has -- (), has not -- (), been listed on the Environmental Protection Agency List of Violating Facilities;

The bidder or offeror certifies as follows:

- (i) any facility to be utilized in the performance of this proposed contract has -- () has not -- () been listed on the Environmental Protection Agency List of Violating Facilities;
- (ii) he will promptly notify the Contracting Officer, prior to award, of the receipt of any communication from the Director, Office of Federal Activities, U.S. Environmental Protection Agency, indicating that any facility which he proposes to use for the performance of the contract is under consideration to be listed on the EPA list of Violating Facilities; and
- (iii) he will include substantially this solicitation certification, including this paragraph (iii), in every nonexempt subcontract.

8. REFERENCE TO AMENDMENTS: Each bidder shall refer in his bid to all amendments to this specification; failure to do so may constitute an informality in the bid.

Marine Corps Base
Jacksonville, North Carolina Area

DIVISION 1. GENERAL REQUIREMENTS

SECTION 01011. General Paragraphs

01012. Additional General Paragraphs

SECTION 01011. GENERAL PARAGRAPHS

1. GENERAL INTENTION: It is the declared and acknowledged intention and meaning to provide and secure replace water wells complete and ready for use.

2. GENERAL DESCRIPTION: The work includes provision of new wells and well pumps, diesel engine drive for one pump, prefabricated metal well houses, water distribution piping, electrical work, storm drains, paving, concrete work, demolition of existing well houses, and incidental related work.

3. LOCATION: The work shall be located at the Marine Corps Base, Camp Lejeune, North Carolina approximately as shown. The exact location will be indicated by the Contracting Officer.

4. COMMENCEMENT, PROSECUTION, AND COMPLETION OF WORK: The Contractor will be required to commence work under the contract 15 calendar days after the date of "Notice of Award", to prosecute said work diligently, and to complete the entire work ready for use within 270 calendar days. The time stated for completion shall include final cleanup of the premises. The contract completion date will be computed starting 15 calendar days after the date of the Notice of Award. This 15 day period is to allow for mailing of the Notice of Award and the Contractor's submission of required bonds.

5. LIQUIDATED DAMAGES: In case of failure on the part of the Contractor to complete the work within the time fixed in the contract or any extensions thereof, the Contractor shall pay to the Government as liquidated damages pursuant to Clause 5, "Termination for Default-Damages for Delay - Time Extensions," and Clause 80, "Damages for Delay - Defense Materials System and Priorities" of the General Provisions the sum of \$35.00 for each day of delay.

6. DRAWINGS ACCOMPANYING SPECIFICATION: The following drawings accompany this specification and are a part thereof. Drawings are the property of the Government and shall not be used for any purpose other than that contemplated by the specification. The drawings included with this specification are half-size. Full-size drawings are available at the bidder's or Contractor's expense. Information on procuring these full-size drawings may be obtained from the Contracting Officer. Full-size drawings may be inspected during regular working hours at the office of the Contracting Officer.

<u>EFD Dwg. No.</u>	<u>NAVFAC Dwg. No.</u>	<u>Title</u>
133402	4033402	Civil - Vicinity and Location Plan
133403	4033403	Civil - Site Plan
133404	4033404	Civil - Site Plan
133405	4033405	Wellhouse Details
133406	4033406	Wellhouse Details
133407	4033407	Electrical - Plans and Details

7. **FACTORY INSPECTION:** (See Clause 10 of the General Provisions.)
 Factory inspection of material and equipment for which tests at the place of manufacture are required in referenced specifications will be waived if notarized copies of factory reports are furnished that show compliance with the specification requirements. Factory inspection will be required only where specified herein or in the technical sections of this specification. The Government reserves the right to charge to the Contractor any additional cost of Government inspection and tests when materials and equipment are not ready at the time inspection and tests are requested by the Contractor.

8. **SAMPLES:** As soon as practicable, and before installation, submit to the Commander, Atlantic Division, Naval Facilities Engineering Command, Code 05, Naval Station, Norfolk, Virginia 23511 for approval samples of materials and equipment as may be requested including: all samples required in the technical sections of this specification.

9. **SUBMITTAL OF SHOP DRAWINGS, MANUFACTURERS DATA AND CERTIFICATIONS REQUIRED OF THE CONTRACTOR:** As soon as practicable after award of the contract, and before procurement or fabrication, submit to the Commander, Atlantic Division, Naval Facilities Engineering Command, Code 05, Naval Station, Norfolk, Virginia 23511 all the shop drawings, manufacturers data and certifications required in the technical sections of this specification. Seven copies of all submittals to be approved by the Contracting Officer shall be forwarded. One copy of transmittal form for all submittals shall be forwarded to the Resident Officer in Charge of Construction. Specification MIL-D-1000 shall be used as a guide and its use is encouraged, for all drawings and data submitted by the Contractor. Conformance to the provisions of specification MIL-D-1000 is not mandatory for maps, sketches, presentation drawings, perspectives, renderings, and all other drawings not requiring Naval Facilities Engineering Command drawings numbers.

10. **MINIMUM WAGE RATES AND OTHER LABOR STANDARDS:** The Contractor shall pay mechanics and laborers employed or working directly upon the site of the work wage rates not less than those contained in the attached wage determination decision of the Secretary of Labor No. NC75-1078.

11. SAFETY PROGRAM: The Contractor shall implement a safety program conforming to the requirements of Federal, State and Local laws, rules and regulations. The program shall include, but is not limited to, the following:

a. "Occupational Safety and Health Standards", which can be ordered from the Superintendent of Documents, U. S. Government Printing Office, Washington, D.C. 20402.

b. Department of the Army, Corps of Engineers, "General Safety Requirements", which may be examined in the office where bids are being received.

c. General Provisions, Clause 45.

12. AVAILABILITY OF UTILITIES SERVICES: Clause 56, "Availability and Use of Utility Services" of the General Provisions applies. Reasonable amounts of utilities will be made available to the Contractor at the prevailing Government rates, which may be obtained upon application to the Commanding Officer. The Contractor will be responsible for making connections, providing transformers and meters, and making disconnections.

13. TRAILER OR STORAGE BUILDINGS will be permitted on the job site, where space is available, subject to the approval of the Contracting Officer. The trailers or buildings shall be suitably painted and kept in a good state of repair. Failure of the Contractor to maintain his trailers or storage buildings in good condition will be considered sufficient reason to require their removal from the job site.

14. WRITTEN GUARANTEES AND GUARANTOR'S LOCAL REPRESENTATIVE: Prior to completion of the contract, the Contractor shall obtain and furnish to the Contracting Officer's designated representative written guarantees for all the equipment and/or appliances furnished under the contract. The Contractor shall furnish with each guarantee: The name, address, and telephone number of the guarantor's representative nearest to the location where the equipment and/or appliances are installed, who, upon request of the Using Service's representative, will honor the guarantee during the guaranty period and will provide the services prescribed by the terms of the guarantee. At the time of installation, the Contractor shall tag each item of warranted equipment with a durable, oil and water resistant tag approved by the Contracting Officer. Leave the date of acceptance and inspector's signature blank until project is accepted for beneficial occupancy. Tag shall show the following information:

EQUIPMENT WARRANTY TAG

Type of Equipment.....
Accepted Date.....
Warranted Until.....
Under Contract N62470-.....
Inspector's Signature.....

STATION PERSONNEL TO PERFORM ONLY OPERATIONAL MAINTENANCE

15. TECHNICAL PUBLICATIONS: The Contractor shall furnish to the Contracting Officer three copies each of installation, operation maintenance manuals and parts list for all Contractor-furnished mechanical and electrical equipment.

15.1 Operating instructions for the principal plant mechanical and electrical components, for use by operating personnel, shall be provided. They shall be laminated between thermoplastic sheets and affixed where directed. The instructions shall describe the function of the equipment, its most economical operation, start-up and shut-down procedures, procedures to follow in the event of failure, normal maintenance practices, and caution and warning notices.

15.2 Maintenance and operation manual shall be furnished to the Contracting Officer for approval. The manual shall be mounted in flexible binders with oil-resistant covers and shall contain, but not be limited to, installation and operating instructions, maintenance procedures, illustrations, drawings, detailed descriptions, tests, adjustment, safety precautions, and parts list.

15.3 Parts list, giving part numbers and prices for the equipment furnished, shall be submitted to the Contracting Officer as soon as practicable after the award of the contract, but not later than 90 days after notice of award has been received.

16. IDENTIFICATION: All catalog cuts, shop drawings, samples and other data submitted for approval shall specifically identify the specification paragraph or contract drawing by number where each item submitted is required to be provided. All submittals shall be clearly marked in ink to indicate the specific items submitted for approval.

17. SCHEDULING THE WORK: Immediately after award, the Contractor shall meet with the Contracting Officer and prepare a schedule of work. The Activity will remain in operation during the entire construction period and the Contractor shall conduct his operations so as to cause the least possible interference with the normal operations of the activity.

The new wells and pumps and water distribution systems shall be useably complete and in operation as approved by the Contracting Officer before any work is started on demolishing existing well houses and water piping and capping existing wells (see also section entitled "Demolition"). Permission to interrupt any utility service shall be requested in writing at least ten days in advance and approval of the Contracting Officer shall be received before any service is interrupted. Interruptions of utility services will be allowed only when they will cause no interference with the operations of the activity. All utility cutovers shall be made after normal working hours or on weekends; anticipated costs shall be included in the bid. The normal working hours are from 8:00 a.m. to 4:30 p.m. Monday through Friday.

18. NORTH CAROLINA SALES AND USE TAX is required. (SEE also section entitled "Additional General Paragraphs".)

19. EMERGENCY MEDICAL CARE: Emergency medical care only is available at Government facilities at Marine Corps Base, Camp Lejeune (to Contractor employees who suffer on-the-job injury or disease). Emergency care will be rendered at the prevailing rates established in BUMEDINST 6320.4 series. Reimbursement will be made by the Contractor to the Naval Regional Medical Center Collection Agent upon receipt of a monthly statement.

20. Quarantine for white fringed beetles. The entire Camp Lejeune reservation (including Camp Geiger) and the Marine Corps Air Facility, New River, have been quarantined by the United States and North Carolina Departments of Agriculture for the white fringed beetle. Compliance with the quarantine regulations established by these authorities as set forth in the U.S.D.A. Quarantine No. 72 and North Carolina State Quarantine No. 7 is required for operations hereunder. Pertinent requirements of the quarantines include the following:

(a) Certification is required for the following articles and they shall not be moved from the reservation unless accompanied by a valid inspection certificate issued by an authorized white fringed beetle inspector.

(1) Soil, sand, or gravel moved independently or attached to other articles, such as heavy equipment including drag lines, road-grading machines, ditch diggers, bulldozers, and equipment with tracks or cleats.

(2) Nursery stock, plants and sod.

(3) Scrap metal.

Authorization for movement of equipment shall be obtained from the Contracting Officer and requests for inspection shall be made sufficiently in advance of the date of movement to permit arrangements for the services of authorized inspectors. The equipment shall be prepared and assembled so that it may be readily inspected. Articles and materials requiring certification for movement shall be removed from the equipment by washing with water and such other means as necessary to accomplish complete removal. Resulting spoil shall be wasted as directed.

21. QUARANTINE FOR IMPORTED FIRE ANT (7/76). All of Onslow, Jones and Cartaret Counties and portions of Duplin and Craven Counties have been declared a generally infested area by the United States Department of Agriculture for the imported fire ant. Compliance with the quarantine regulations established by this authority as set forth in USDA Quarantine No. 81 dated 9 October 1970, and USDA Publication 301.81-2A of 23 July 1976, is required for operations hereunder. Pertinent requirements of the quarantine for materials, originating on the Camp Lejeune reservation and the Marine Corps Air Station (Helicopter), New River, which are to be transported outside the Onslow County or adjacent suppression areas, include the following:

(a) Certification is required for the following articles, and they shall not be moved from the reservation to any point outside the Onslow County and adjacent designated areas unless accompanied by a valid inspection certificate issued by an authorized imported fire ant inspector.

(1) Bulk soil.

(2) Used mechanized soil-moving equipment.

(3) Any other products, articles, or means of conveyance of any character whatsoever, not covered by sub-divisions (1) and (2), when it is determined by an inspector that they present a hazard of spread of the imported fire ant and the person in possession thereof has been so notified.

(b) Authorization for movement of equipment shall be obtained from the Contracting Officer, and requests for inspection shall be made sufficiently in advance of the date of movement to permit arrangements for the services of authorized inspectors. The equipment shall be prepared and assembled so that it may be readily inspected. All soil on or attached to equipment, supplies and materials shall be removed from the equipment by washing with water and such other means as necessary to accomplish complete removal. Resulting spoil shall be wasted as directed.

---oOo---

1917. The first of these was the
... ..
... ..
... ..
... ..
... ..

... ..
... ..
... ..
... ..
... ..
... ..

... ..
... ..
... ..
... ..
... ..
... ..
... ..
... ..
... ..
... ..

... ..
... ..
... ..

SECTION 01012. ADDITIONAL GENERAL PARAGRAPHS

1. FORM OF CONTRACT: The contract will be executed on Standard Form 23, January 1961 edition, Construction Contract, and will include Labor Standards Provisions (November 1975); General Provisions (January 1977).

2. CERTIFICATION OF NONSEGREGATED FACILITIES:

(a) Certification of nonsegregated facilities. By the submission of this bid, the bidder, offeror, applicant, or subcontractor certifies that he does not maintain or provide for his employees any segregated facilities at any of his establishments, and that he does not permit his employees to perform their services at any location, under his control, where segregated facilities are maintained. He certifies further that he will not maintain or provide for his employees any segregated facilities at any of his establishments, and that he will not permit his employees to perform their services at any location, under his control, where segregated facilities are maintained. The bidder, offeror, applicant or subcontractor agrees that a breach of this certification is a violation of the Equal Opportunity Clause in this contract. As used in this certification, the term "segregated facilities" means any waiting rooms, work areas, rest rooms and wash rooms, restaurants and other eating areas, time clocks, locker rooms and other storage or dressing areas, parking lots, drinking fountains, recreation or entertainment areas, transportation, and housing facilities provided for employees which are segregated by explicit directive or are in fact segregated on the basis of race, creed, color, or national origin, because of habit, local custom or otherwise. He further agrees that (except where he has obtained identical certifications from proposed subcontractors for specific time periods) he will obtain identical certifications from proposed subcontractors prior to the award of subcontracts exceeding \$10,000 which are not exempt from the provisions of Equal Opportunity clause; that he will retain such certifications in his files; and that he will forward the following notice to such proposed subcontractors (except where the proposed subcontractors have submitted identical certifications for specific time periods):

NOTICE TO PROSPECTIVE SUBCONTRACTORS OF REQUIREMENT FOR CERTIFICATIONS OF NONSEGREGATED FACILITIES.

A certification of Nonsegregated Facilities, as required by the May 9, 1967 order on Elimination of Segregated Facilities, by the Secretary of Labor (32 Fed. Reg. 7439, May 19, 1967) must be submitted prior to the award of a subcontract exceeding \$10,000 which is not exempt from the provisions of the Equal Opportunity clause. The certification may be submitted either for each subcontract or for all subcontracts during a period (i.e., quarterly, semiannually, or annually). (Mar. 1968) (Note: The penalty for making false statements in offers is prescribed in 18 U.S.C. 1001).

(b) Certification of nonsegregated facilities by subcontractors and federally assisted construction contractors (Mar. 1968). Prior to the award of any subcontract, required to contain the Equal Opportunity clause contained in this contract, the Contractor shall obtain the certification set forth in 2-201(a) (xli). This certification may be required by the Contractor, either for each subcontract or for all subcontracts during a period (i.e., quarterly, semiannually, or annually).

3. **METHODS AND SCHEDULES OF PROCEDURES:** The work shall be executed in a manner and at such times that will cause the least practicable disturbance to the occupants of the buildings and the normal activities of the station. Before starting any work, the sequence of operations and the methods of conducting the work shall have been approved by the Contracting Officer

4. **APPROVAL OF SAMPLES, CUTS, AND DRAWINGS:** Matter submitted for approval shall be accompanied by complete information concerning the material, articles, and/or design proposed for use in sufficient detail to show compliance with the specification, and shall be approved before incorporation into the work. Approval thereof will not be construed as relieving the Contractor of compliance with the specification, even if such approval is made in writing, unless the attention of the Contracting Officer is called to the noncomplying features by letter accompanying the submitted matter. Partial submittals or submittals of less than the whole of any system made up of interdependent components, will not be considered. Approval of drawings, cuts, and samples by the Contracting Officer shall not be construed as a complete check or approval of the detailed dimensions, weights, gauges and similar details of the proposed articles. The conformance of such details with the contract requirements, together with the necessary coordination of dimensions and details between the various elements of the work and between the various subcontractors and suppliers, shall be solely the responsibility of the Contractor, approval of submitted matter notwithstanding.

5. **OPERATION OF STATION UTILITIES:** The Contractor shall not operate nor disturb the setting of any control devices in the station utilities system, including water, sewer, electrical and steam services. The Government will operate the control devices as required for normal conduct of the work. The Contractor shall notify the Contracting Officer giving reasonable advance notice when such operation is required.

6. **CHANGED CONDITIONS:** Wherever changed conditions as defined in Clause 4 of the General Provisions are encountered, and wherever conditions exposed during the course of the work necessitate a change from quantities indicated or specified as either estimated quantities or as a basis for bids, whether or not provision for a change in price for such variation is specified, the Contracting Officer must be notified in writing and written directions to do so must be obtained before quantities stated in the contract documents are exceeded.

7. **SUBCONTRACTORS AND PERSONNEL:** Promptly after the award of the contract, the Contractor shall submit to the Contracting Officer, in triplicate, a list of his subcontractors and the work each is to perform. On this form shall appear the names of the key personnel of the Contractor and subcontractors, together with their home addresses and telephone numbers, for use in event of any emergency. From time to time as changes occur and additional information becomes available, the Contractor shall amplify, correct, and change the information contained in previous lists.

8. **SAFETY REQUIREMENTS:** A copy of the Department of the Army, Corps of Engineers, "General Safety Requirements", referenced in Clause 45 of the General Provisions, may be examined in the office where the bids are being received. Prior to starting the work, the Contractor

shall meet in conference with representatives of the Contracting Officer to discuss and develop mutual understandings relative to administration of the safety program.

9. AS-BUILT DRAWINGS: On completion of the work, one full-size print of each of the drawings accompanying this specification shall be neatly and clearly marked in red to show all variations between the construction actually provided and that indicated or specified in the contract documents, and delivered to the Contracting Officer. The Contractor shall also mark the drawings to indicate the exact location of any underground utility lines discovered in the course of the work. Where a choice of materials and/or methods is permitted herein, and where variations in the scope or character of the work indicated or specified are permitted either by award on bidding items specified for that purpose or by subsequent change to the contract, the as-built drawings shall define the construction actually provided. The representation of such variations shall conform to standard drafting practice and shall include such supplementary notes, legends, and details as may be necessary for legibility and clear portrayal of the as-built construction; the marked prints shall be subject to approval of the Contracting Officer before acceptance.

10. RESPONSIBILITY FOR TESTING: Where tests are specified to be made by the Government, the Government will make the initial tests at its expense. Should the initial samples fail to meet the requirements of the specifications, all succeeding tests of additional samples shall be made by an approved testing laboratory or agency at the expense of the Contractor.

11. SCHEDULE OF PRICES: Unless otherwise specified in the section entitled "General Paragraphs", upon receipt of a notice of award, the Contractor shall prepare a detailed breakdown of the contract price, giving the quantities of the various kinds of work and the unit and total prices therefor. This breakdown shall be submitted promptly to the Contracting Officer on form NAVFAC 4330/4, Schedule of Prices, in octuplicate. The forms will be furnished by, and shall be executed in a manner satisfactory to, the Contracting Officer. The submission of this breakdown will not affect the contract terms.

12. PRINTS FURNISHED TO CONTRACTOR: Five copies of the project specification, five sets of one-half size prints and one set of full-size reproducibles of each drawing accompanying this specification will be furnished the Contractor without charge. Additional prints and full-size prints required by the Contractor shall be reproduced by him at his own expense.

13. LOCATION OF UNDERGROUND UTILITIES: Where existing piping, utilities, and underground obstructions of any type are indicated in locations to be traversed by new piping, ducts, and other work provided hereunder, and are not indicated or specified to be removed, the elevations of the existing utilities and obstructions shall be determined before the new work is laid closer than the nearest manhole or other structure at which an adjustment in grade could be made. For any additional work required by reason of conflict between the new and existing work, an adjustment in contract price will be made in accordance with Clause 4 of the General Provisions.

14. CERTIFICATE OF CURRENT COST OR PRICING DATA: (This paragraph is to be used when certification of cost or pricing data is required in accordance with ASPR 3-807.3.) The Contractor shall submit to the Contracting Officer a certificate in the form set forth below as soon as practicable after agreement is reached on the contract price:

CERTIFICATE OF CURRENT COST OR PRICING DATA

This is to certify that, to the best of my knowledge and belief, cost or pricing data as defined in ASPR 3-807.3(h) submitted, either actually or by specific identification in writing (see ASPR 3-807.3(i)), to the Contracting Officer or his representative in support of _____

_____ * are accurate, complete, and current as of _____
**.
_____ day month year

_____ ***
Date of Execution

Firm _____
Name _____
Title _____

- * Describe the proposal, quotation, request for price adjustment or other submission involved, giving appropriate identifying number (e.g., RFP No. _____).
- ** This date shall be the date when the price negotiations were concluded and the contract price was agreed to. The responsibility of the Contractor is not limited by the personal knowledge of the Contractor's negotiator if the Contractor had information reasonably available (see ASPR 3-807.5(a)) at the time of agreement, showing that the negotiated price is not based on accurate, complete, and current data.
- *** This date should be as close as practicable to the date when the price negotiations were concluded and the contract price was agreed to.

15. NORTH CAROLINA SALES AND USE TAX

(a) As used throughout this clause, the term "materials" means building materials, supplies, fixtures and equipment which become a part of or are annexed to any building or structure erected, altered, or repaired under this contract.

(b) If this is a fixed-price type contract as defined in the Armed Services Procurement Regulation, the contract price includes North Carolina sales and use taxes to be paid with respect to materials, notwithstanding any other provision of this contract. If this is a cost-reimbursement type contract as defined in such regulation, any North Carolina sales and use taxes paid by the Contractor with respect to materials shall constitute an allowable cost under this contract.

(c) At the time specified in paragraph (d) below:

(i) The Contractor shall furnish the Contracting Officer certified statements setting forth the cost of the materials purchased from each vendor and the amount of North Carolina sales and use taxes paid thereon. In the event the Contractor makes several purchases from the same vendor, such certified statement shall indicate the invoice numbers, the inclusive dates of the invoices, the total amount of the invoices and the North Carolina sales and use taxes paid thereon. Such statement shall also include the cost of any tangible personal property withdrawn from the Contractor's warehouse stock and the amount of North Carolina sales or use tax paid thereon by the Contractor. The Contractor shall furnish such additional information as the Commissioner of Revenue of the State of North Carolina may require to substantiate a refund claim for sales or use taxes.

(ii) The Contractor shall obtain and furnish to the Contracting Officer similar certified statements by its subcontractors.

(d) If this contract is completed before the next October 1, the certified statements to be furnished pursuant to paragraph (c) above shall be submitted within 60 days after completion. If this contract is not completed before the next October 1, such certified statements shall be submitted on or before the 30th day of November of each year and shall cover taxes paid during the twelve month period which ended the preceding September 30.

(e) The certified statements to be furnished pursuant to paragraph (c) above shall be in the following form:

I hereby certify that during the period _____ to _____, (name of Contractor or subcontractor) paid North Carolina sales and use taxes aggregating \$ _____ with respect to building materials, supplies, fixtures and equipment which have become a part of or annexed to a building or structure erected, altered or repaired by (name of Contractor) for the United States of America, and that the vendors from whom the property was purchased, the dates and numbers of the invoices covering the purchases, the total amount of the invoices of each vendor, the North Carolina sales and use taxes paid thereon, and the cost of property withdrawn from warehouse stock and North Carolina sales or use taxes paid thereon are as set forth in the attachments hereto.

---oOo---

05-76-6799

01012 - 5

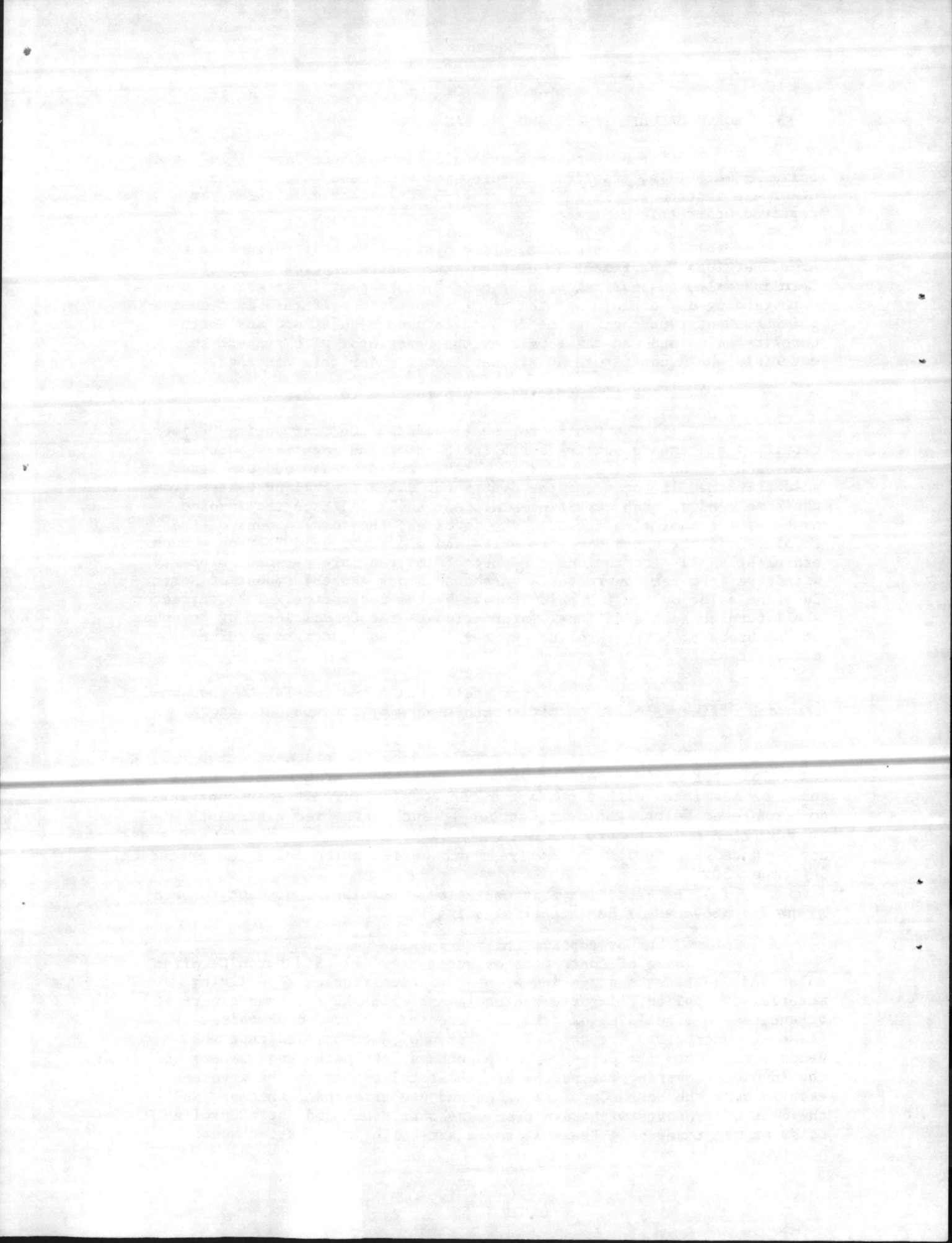

SECTION 02110. DEMOLITION

1. SUBMITTALS:

1.1 Procedures: The procedures proposed for the accomplishment of demolition work shall be submitted to and approved by the Contracting Officer before work is started. The procedures shall provide for safe conduct of the work, protection of property which is to remain undisturbed, coordination with other work in progress, and timely disconnection of utility services. The procedures shall include a detailed description of the methods and equipment to be used for each operation, and the sequence of operations.

2. REQUIREMENTS: The work includes the demolition and removal of all construction indicated, specified, or necessary to accomplish the work under this contract. The work indicated or specified in this section or other sections of the specifications is included, but is not intended that all items of demolition work be specifically indicated, specified, or listed. After carefully reviewing the drawings and specifications to determine intent, the Contractor shall visit the site and determine the extent of demolition work required to properly complete the work under this contract.

2.1 Demolition and removal shall be conducted in a manner that will eliminate hazards to persons and property in the area and shall prevent the release of dust and rubbish into the air. All debris resulting from demolition or removal work shall be removed from the station daily or as directed by the Contracting Officer. Trash and rubbish shall not be allowed to accumulate. Demolished materials and debris which in the opinion of the Contracting Officer cannot practicably be removed from the site the same day as removed, may be temporarily stacked or stored in a designated location on the site as directed by the Contracting Officer. All materials resulting from demolition work, except as indicated or specified otherwise, shall become the property of the Contractor and shall be removed from the limits of the station.

2.2 Dust Control: The amount of dust resulting from demolition shall be controlled to avoid creation of a nuisance in the surrounding area. Use of water will not be permitted when it will result in, or create, hazardous or objectionable conditions such as ice, flooding and pollution.

2.3 Protection of Existing Work: Before beginning any cutting or demolition work, the Contractor shall carefully survey the existing work and examine the drawings and specifications to determine the extent of the work. The Contractor shall take all necessary precautions to insure against damage to existing work to remain in place, to be reused, or to remain the property of the Government and any damage to such work shall be repaired or replaced, as approved by the Contracting Officer, at no additional cost to the Government. The Contractor shall carefully coordinate the work of this section with all other work and construct and maintain shoring, bracing and supports, as required.

2.4 Use of Explosive: Use of explosives will not be permitted.

2.5 Filling: Holes resulting from demolition and removal work shall be filled as specified in Section entitled "Earthwork" and vegetated as specified in Section entitled "Establishing Vegetation".

2.6 Structures: Existing structures indicated shall be removed shall be removed in their entirety down to and including removal of building floor slabs and footings and engine foundations.

2.7 Utilities: Remove all existing utilities as indicated, and terminate in a manner and at a time satisfactory to the Government. Water lines shall be terminated where shown, using appropriate cast iron blind flanges. Capping of wells is specified in section entitled "Wells". When utility lines are encountered that are not indicated on the drawings, they shall be disposed of as directed by the Contracting Officer and disposal shall be covered by Differing Site Conditions in accordance with the General Provisions.

3. DISPOSITION OF MATERIAL:

3.1 Title to Materials: Title to all materials and equipment to be demolished, except as specified otherwise, is vested in the Contractor upon receipt of notice to proceed. The Government will not be responsible for the condition, loss or damage to such property after notice to proceed.

3.2 Equipment to be Removed by the Government: All existing equipment in the well houses will be removed by the Government, and will remain the property of the Government. The Contractor shall notify the Contracting Officer, in writing, at least 14 days in advance of the time he proposes to begin demolition of each well house so that arrangements can be made for removal of equipment by the Government.

4. SCHEDULING DEMOLITION: No well house may be demolished, nor its associated well and water system abandoned, until the replacement well and water distribution system for the respective well house is completed and in operation and supplying the specified quantity of water. Moreover, the existing wells and water supply systems shall be maintained in operation at all times until the respective replacement wells and water supply systems are in operation.

---oOo---

SECTION 02201
EARTHWORK

1. APPLICABLE PUBLICATIONS: The following publications of the issues listed below, but referred to elsewhere by basic designation only, form a part of this specification to the extent indicated by the references thereto (where a number is suffixed to the specification number, it denotes the effective amendment to the specification):

1.1 American Association of State Highway Officials (AASHO):

T99-70 Moisture-density relations of soils, 5.5 lb. rammer.

2. QUALITY CONTROL: See Paragraph entitled "Tests" hereinafter.

3. REQUIREMENTS: The work includes the clearing and the excavation, filling, backfilling, and grading indicated and necessary for proper completion of the project.

3.1 General: Bids shall be based on the following:

(a) that the surface elevations are as indicated;

(b) that no pipes or other artificial obstructions, except those indicated, will be encountered; and

(c) that hard material will not be encountered.

In case the actual conditions differ substantially from those stated or shown, or both, the provisions of the contract respecting an adjustment for changed conditions shall apply, subject to the requirement of notification thereunder being given. Hard material shall be defined as solid ledge rock, firmly cemented unstratified masses or conglomerate deposits possessing the characteristics of solid rock not ordinarily removed without systematic drilling and blasting, and any boulder, masonry, or concrete except pavement, exceeding 1/2 cubic yard in volume.

3.2 Clearing: All trees, logs, shrubs, and brush within the indicated clearing limits shall be removed, except as indicated otherwise. Trees and shrubs which are not to be cut shall be properly protected from damage. Bushes, roots and matted roots shall be grubbed out at least 18 inches below the existing surface. Brush, refuse, stumps, roots, and timber shall be removed from the limits of the station.

3.3 Topsoil: Existing topsoil shall be stripped to a depth of 4 inches, stockpiled separately from other excavated materials, and shall be reused for finished surface grading. Topsoil shall be free of stones, wood matter, cuttings, excessive quantities of vegetation, and debris of every kind. Piles of topsoil shall be located so that the material can be used readily for finished surface grading; topsoil shall be protected and maintained until needed. The top 4-inch thickness of all newly graded earth surfaced areas shall consist of topsoil. Any surplus of topsoil from excavations and grading shall be stockpiled on the station at a location within 5000 feet of the site of the work, as directed by the Contracting Officer. If there is insufficient topsoil available to

form the 4-inch thickness, that available shall be utilized as directed. The Contractor will not be required to haul in additional topsoil if all requirements specified are complied with. Placing of topsoil is specified in the section entitled "Establishing Vegetation".

3.4 Excavations shall be carried to the depths, contours and dimensions indicated or necessary. Excavations shall be kept free from water while construction therein is in progress.

3.4.1 Excavations for structures and trenches: Excavations carried below the depths indicated, without specific directions of the Contracting Officer, shall be refilled to the proper grade with suitable material and compacted thoroughly, except that in excavations for footings the concrete shall be extended to the bottom of the excavations; all additional work of this nature shall be at the Contractor's expense. Trenches for pipe lines shall be excavated along straight lines and, unless indicated otherwise, shall provide a minimum of 6 inches between the outside of the pipe bell and the sides of the trench or bracing. Standard pipe trench excavation and bedding shall be in accordance with the Standard Pipe Trench Bedding details given at the end of this section. Pipe, except cast iron or steel shall have its bottom quadrant for the full length of the barrel embedded in undisturbed earth. Mechanical excavation shall be held at least 2 inches above final invert grade. The remainder of the excavation shall be shaped manually and graded to provide uniform bearing on compacted soil, immediately before the pipe is laid.

3.4.2 Excavation under new pavements and concrete slabs: The entire area of the original ground under new pavements and concrete slabs shall be excavated to remove all vegetable matter, topsoil, sod, muck, rubbish, and other unsuitable material to a minimum depth of 6 inches. In the event that the Contractor is directed by the Contracting Officer to remove unsuitable material to a greater depth than specified, an adjustment in the contract price or time for completion, or both, will be made in accordance with the contract.

3.4.3 Shoring and sheeting: Excavations shall be shored and sheeted with members of sizes and arrangement sufficient to prevent injury to persons, damage to structures, injurious caving, or erosion. Shoring, sheeting, and bracing shall be removed as the excavations are backfilled; care shall be exercised to prevent injurious caving during the removal of the shoring and sheeting.

3.5 Borrow materials, if required, shall be obtained from the station borrow pit or from sources outside the station, at the Contractor's option. The station borrow pit is located within a haul distance of 5 miles from the site of the work. If the station borrow pit is used, the Contractor, at his expense, shall perform any clearing, grubbing, and stripping required for providing access to suitable borrow material and shall dispose of materials from clearing and grubbing operations off the

station. The Contractor, at his expense, shall also remove and stockpile the top 12 inches of soil material in the area in which he is to get the borrow. After the borrow material has been removed, the borrow pit shall be trimmed neatly and graded to drain properly and the stockpiled soil material replaced and leveled over the borrow area. If the borrow materials are provided from sources outside the station, they shall be at the Contractor's expense.

3.6 Drainage of construction sites: It shall be the Contractor's responsibility to adequately and completely drain construction sites as required to keep subgrades and subsoils sufficiently dry to permit all construction operations to successfully progress during all periods in which work is in progress. In addition to permanent drainage features required, the Contractor shall provide all necessary additional temporary ditches, swales, and other drainage features and equipment required to maintain the soils dry during construction. Where the Contractor's operations or failure to comply with the above requirements results in the development of unsuitable working platforms for equipment operation and unsuitable soil support for subsequent construction features, the Contractor shall, at his expense, remove the unsuitable material to whatever depth is required to restore suitable working platforms and soil support and replace it with suitable material from sources outside the station.

3.7 Filling and backfilling:

3.7.1 Filling and backfilling for structures and trenches: All fill and backfill shall be free from roots, wood or other scrap material, and other vegetable matter and refuse. Fill and backfill shall be placed in layers not more than 6 inches thick, except as specified otherwise herein, and each layer shall be compacted thoroughly and evenly. Backfill about structures shall be placed, as far as practicable, as the work of construction progresses. Backfilling of trenches shall progress as rapidly as the construction and testing of the work permits. In backfilling pipe trenches, approved fill shall be compacted in 6-inch layers to a depth of one foot over the top of the pipe; the remainder of the trench shall be backfilled in well-compacted one-foot layers, except that for trenches in pavements the backfill shall be compacted in 6 inch layers to the top of the trench.

3.8 Compaction: The subgrade of soils in cut shall have a density of 95 percent of the maximum density to a depth of 12 inches below the subgrade surface. If the density of the existing material is less than 95 percent, it shall be compacted to a depth of 12 inches to the minimum 95 percent density. Fill and backfill under concrete floor slabs and the upper 12 inches under pavements shall be compacted to not less than 100 percent of the maximum density for cohesionless materials and 95 percent of the maximum density for other materials; under grassed areas to 85 percent; and other backfill adjacent to structures to 90 percent. The moisture content of the specified densities shall be within 2 percent more or less than the optimum.

3.9 Grading: The Contractor shall perform all grading in the areas so indicated or specified. Surfaces which are to receive topsoil shall be depressed as required to receive the topsoil. Fill shall be brought to finished grades indicated within a tolerance of one-tenth of a foot and shall be graded to drain away from structures. Existing grades which are to remain and which are disturbed by the Contractor's operations shall be graded to provide surfaces suitable for the proper use of mowing machines.

3.10 Granular fill (indicated as porous material) under concrete floor slabs shall be provided by the Contractor from sources outside the station, and shall consist of clean crushed rock, crushed or uncrushed gravel, uniformly graded and of a size that will pass a 1-1/2 inch sieve and will be retained on a no. 4 sieve. The porous material layer shall be not less than 4 inches in compacted thickness, and shall be compacted with a minimum of two passes of a hand-operated plate-type vibratory compactor.

3.11 Disposition of surplus material: Surplus soil material not required for filling, backfilling, or grading shall be wasted by deposition on Government property within 2 miles of the site of the work, where directed by the Contracting Officer. Wasted material shall be spread and leveled as directed by the Contracting Officer.

4. TESTS: All tests will be performed by the Government. Maximum density at optimum moisture content will be determined by AASHTO method T99, Method D, with the following modifications: (1) all material passing a 2-inch sieve and retained on a 3/4-inch sieve shall be removed and replaced with an equal portion of material between the no. 4 and 3/4-inch sieves, and (2) a separate batch of material shall be used for each compaction test specimen. No material shall be reused for compaction tests.

---oOo---

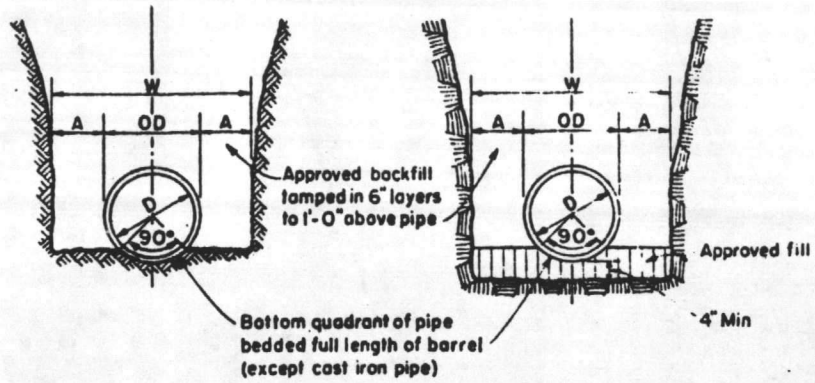

TRENCH IN EARTH

TRENCH IN ROCK

PIPE DIA "D"	MAXIMUM "A"
6" to 15"	8"
18" to 21"	10"
24" to 30"	12"
33" to 42"	15"
48" & Larger	18"

Maximum trench width "W"
taken at top of pipe

STANDARD PIPE TRENCH BEDDING

LANTDIV PLATE

STANDARD FOR TANKER D. 2012

1000

SECTION 02501

STORM DRAINAGE SYSTEMS

1. APPLICABLE PUBLICATIONS: The following publications of the issues listed below, but referred to hereinafter by basic designation only, form a part of this specification to the extent required by the references thereto (where a number is suffixed to the specification number, it denotes the effective amendment to the specification):

1.1 Federal Specifications:

- SS-S-210A(1) Sealing compound, preformed plastic, for expansion joints and pipe joints.
WW-P-405B(1) Pipe, corrugated (iron or steel, zinc coated).

1.2 Non-Government Specifications and Standards:

American Society for Testing and Materials (ASTM)

- C 14-74 Concrete Sewer, Storm Drain, and Culvert Pipe.
C 76-74 Reinforced Concrete Culvert, Storm Drain and Sewer Pipe.
C 443-74 Joints for circular concrete sewer and culvert pipe, using flexible, watertight, rubber type gaskets.

2. SUBMITTALS:

2.1 Certificates: Submit notarized certificates from the manufacturer attesting that the following products conform to all requirements of this specification and of reference documents:

a. Pipe and Pipe Gaskets and Couplings

2.1.1 Sample Certificate: The notarized certificate shall not contain statements that could be interpreted to imply that the product does not meet all requirements specified, such as "as good as"; "achieve the same end use and results as materials formulated in accordance with the referenced specification"; "equal or exceed the service and performance of the specified material". The certificate should simply state that the product conforms to all requirements specified.

SAMPLE CERTIFICATE

The manufacturer hereby certifies that the following products being furnished for this project conform to all requirements of the project specifications and of the reference specifications listed:

MANUFACTURER AND PRODUCT

John Doe Company
Portland Cement, Type I

REFERENCE SPECIFICATION

ASTM C150-74, Type I.

SIGNATURE AND TITLE

NOTARY STATEMENT AND SEAL

3. STORAGE AND HANDLING: Proper facilities shall be provided for handling and lowering sections of pipe into place to avoid injury or damage. Damaged pipe or pipe with damaged coatings shall be removed from the site and replaced with satisfactory pipe at no additional cost to the Government.

4. MATERIALS:

4.1 Concrete Pipe: Pipe may be either reinforced or non-reinforced concrete pipe.

4.1.1 Non-Reinforced Concrete Pipe shall conform to ASTM C14, Class 2.

4.1.2 Reinforced Concrete Pipe shall conform to ASTM C76, Class III.

4.2 Joints for Concrete Pipe shall be one of the following types:

- (a) Bell and spigot with rubber gaskets
- (b) Tongue and groove with rubber gaskets
- (c) Tongue and groove with preformed plastic gaskets
- (d) Bell and spigot with gaskets and mortar
- (e) Tongue and groove with mortar

4.2.1 Rubber Gaskets shall conform to ASTM C443. Only a neutral agent shall be used as a lubricant.

4.2.2 Preformed Plastic Gaskets shall conform to SS-S-210, type I-rope form.

4.3 Corrugated Metal Pipe:

4.3.1 Corrugated iron or steel pipe shall conform to WW-P-405 for Class I or II, Shape 1, Coating "C". Minimum gage of metal, before coating, shall be 16.

4.4 Joints in Corrugated Metal Pipe shall be made with standard coupling bands as specified in the referenced federal specification for the pipe, except that bands with projections will not be permitted.

5. REQUIREMENTS: Work in this section includes storm drainage culverts. Concrete or corrugated metal pipe shall be used for storm drainage system. Excavating, trenching, backfilling, and density tests are specified in section titled "Earthwork".

6. INSTALLATION: Each section of pipe shall be carefully examined before being laid, and defective or damaged pipe shall not be used. Proper facilities shall be provided for lowering sections of pipe into trenches. Under no circumstances shall pipe be laid in water, and no pipe shall be laid when trench conditions or weather are unsuitable for

such work. Diversion of drainage or dewatering of trenches during construction shall be provided as necessary. Pipe shall be laid true to the grades indicated and shall rest upon the pipe bed for the full length of each section. Runs of pipe shall be laid with outside laps or grooved ends upgrade beginning at the lower end of the pipe line. Pipe having its grade or joint disturbed after laying shall be taken up, cleaned, and relaid. All pipe shall be laid so that markings are on top and the inner surfaces abut neatly, tightly, and smoothly. All pipe in place shall be inspected and approved before being covered and concealed.

6.1 Corrugated Metal pipe shall be butted to form a smooth joint; the space between the pipe and coupling bands shall be kept free from dirt and grit so that the corrugations fit snugly. The coupling band while being tightened shall be tapped with a softhead mallet of wood, rubber, or plastic to take up slack and insure a tight joint. Coupling band bolts and damaged areas of the coupling bands and pipe shall be given a coating of asphalt cement. Pipe on which the asphalt coating has been damaged to such extent that satisfactory field repairs cannot be made will be rejected.

6.2 Concrete pipe joints:

6.2.1 Rubber gasket and preformed plastic joint installation shall be in accordance with the printed recommendations of the manufacturer of the joint material. Surfaces to receive lubricants, cements, or adhesives shall be clean and dry. Gaskets and jointing materials shall be affixed to the pipe not more than 24 hours prior to the installation of the pipe, and shall be protected from the sun, blowing dust, and other deleterious agents at all times. Gaskets and jointing materials shall be inspected before installation of the pipe, and any loose or improperly affixed gaskets and jointing materials shall be removed and replaced. The pipe shall be aligned with the previously installed pipe, and the joint pulled together. If, while making the joint, the gasket or jointing material becomes loose and can be seen through the exterior joint recess when the joint is pulled up to within one inch of closure, the pipe shall be removed and the joint remade.

6.2.2 Installation of mortar joints:

6.2.2.1 Mortar shall be a mixture of portland cement, sand, and water mixed in the proportion by volume of 1 part portland cement to 2 parts of clean sand. Water in the mix shall not exceed 6 gallons per sack of cement. Water shall be clean and free of injurious acids, alkalis, and organic impurities. Mortar shall be used within 30 minutes from the time the ingredients are mixed with water.

6.2.2.2 Gasket type joints for bell and spigot pipe shall be made with mortar and picked oakum or hemp gaskets dipped in neat portland cement grout. The bell and the spigot of abutting pipes at the joint shall be cleaned with a wet brush before installing gasket and mortar.

The gaskets shall be rammed compactly in place with a calking tool. After the gasket is in place, the mortar shall be pressed firmly into the joint and finished to a neat 45-degree bevel from the top of the bell to the spigot barrel. The interior of all joints shall be cleaned of surplus mortar. After finishing, the outside of each joint shall be covered carefully and shall be kept damp until just prior to backfilling.

6.2.2.3 Joints in tongue-and-groove pipe. Tongue and grooved ends of abutting pipe shall be cleaned with a wet brush before placing mortar. Mortar shall be placed in sufficient quantities so that when the pipe is inserted into the line, the joint space will be completely filled and a bead of mortar will be formed on the outside. The interior of each joint shall be cleaned of surplus mortar and finished flush with the interior surfaces of the pipe. The outside of each joint shall be kept damp until just prior to backfilling.

---oOo---

SECTION 02608

CRUSHED STONE PAVEMENT

1. APPLICABLE PUBLICATIONS: The following publications of the issues listed below, but referred to elsewhere by basic designation only, form a part of this specification to the extent indicated by the references thereto (where a number is suffixed to the specification number, it denotes the effective amendment to the specification):

1.1 American Association of State Highway and Transportation Officials (AASHTO):

T96-72I Resistance to abrasion of small size coarse aggregate by use of the Los Angeles Machine.

1.2 North Carolina Department of Transportation and Highway Safety (NCDOT):

Standard specifications for roads and structures, dated July 1, 1972.

2. QUALITY CONTROL: All field tests to determine conformance with the specified requirements shall be performed in the presence of the Contracting Officer.

3. SUBMITTALS:

3.1 Certificates: Submit notarized certificates from the manufacturer attesting that the following products conform to all requirements of this specification and of reference documents:

a. Aggregates for surface course

3.1.1 Sample Certificate: The notarized certificate shall not contain statements that could be interpreted to imply that the product does not meet all requirements specified, such as "as good as"; "achieve the same end use and results as materials formulated in accordance with the referenced specification"; "equal or exceed the service and performance of the specified material". The certificate should simply state that the product conforms to all requirements specified.

SAMPLE CERTIFICATE

The manufacturer hereby certifies that the following products being furnished for this project conform to all requirements of the project specifications and of the reference specifications listed:

MANUFACTURER AND PRODUCT

John Doe Company
Portland Cement, Type I

REFERENCE SPECIFICATION

ASTM C150-74, Type I.

SIGNATURE AND TITLE

NOTARY STATEMENT AND SEAL

4. MATERIALS:

4.1 Stone Surface Course: Materials shall be in accordance with the NCDOT "Standard Specifications for Roads and Structures, Sections 905 and 910 for Aggregate Base Course, Standard Size No. 7. When tested in accordance with AASHTO T96, Test Grading A, aggregate shall show a loss not greater than 55 percent.

5. REQUIREMENTS: The work includes construction of a crushed stone surface course for pavements.

Preparation of the subgrade shall be as specified under the section of this specification entitled "Earthwork". Except as specified herein or indicated on the drawings, all work and materials shall be in accordance with the NCDOT "Standard Specifications for Roads and Structures". The provisions therein for method of measurement and payment do not apply.

6. CONSTRUCTION:

6.1 Soil Treatment: Soil sterilization shall be accomplished before the stone surface course is placed. Bromacil, the herbicide to be used, shall be applied at the rate of 15 pounds of the active ingredient per acre. Bromacil shall be applied to the soil as a water suspension with a minimum of 50 gallons of water per acre. The treated soil shall not be disturbed between herbicide application and placement of stone materials.

6.2 Crushed Stone Surface Course: Spreading of the stone material shall begin at the point nearest the source of supply. Hauling shall be done and traffic permitted over the course to assist in compaction. Any ruts formed by the traffic shall be carefully filled and re-rolled. After the surface course is in place, machining and rolling shall continue until the surface is smooth, hard, well bonded, and true to the designed cross section. Compaction of 100 percent of maximum density, as determined by the method specified in the section entitled "Earthwork", shall be obtained in the surface course. The surface shall be machined as often as necessary to maintain it smooth and true to grade and cross section until the acceptance of the work.

---o0o---

05-76-6799

02608 - 2

SECTION 02822

ESTABLISHING VEGETATION

1. QUALITY CONTROL:

1.1 Inspection, samples, and tests:

1.1.1 Seed: Furnish duplicate signed copies of a statement from the vendor, certifying that each container of seed is fully labeled in accordance with the Seed Improvement Association requirements for certification. This certification shall appear on, or with, all copies of invoices for the seed. Each lot of seed will be subject to sampling and testing at the discretion of the Contracting Officer. Sampling and testing will be in accordance with the latest regulation under the Federal Seed Act. Samples shall be submitted at least 40 days in advance of the planned planting date.

1.1.2 Fertilizer: Furnish duplicate copies of invoices for all fertilizer used on the project. Invoices for fertilizer shall show the analysis and the quantity furnished. Upon completion of the project, a final check of the total quantities of fertilizer used will be made against the total area seeded and if the rates of application have not been met, additional quantities of these materials shall be applied to make up the application specified.

1.1.3 Mulch: At least 5 days prior to the initiation of the seeding work, the Contractor shall furnish representative samples of the materials proposed to be used for approval.

1.1.4 Asphalt adhesives: The Contractor shall demonstrate before starting the work that the application of asphalt will be made at the specified rates and that method of application is satisfactory. The Contractor shall furnish copies of manufacturer's specifications for asphalt adhesives.

2. MATERIALS:

2.1 Fertilizer shall be the standard commercial product of 10-10-10 analysis. All fertilizer shall be delivered in bags bearing the manufacturer's name, the chemical analysis of the product, and its weight. If not used immediately after delivery, fertilizer shall be stored in a manner that will not allow it to harden or destroy its effectiveness.

2.2 Seed shall be new crop seed labeled in accordance with the U.S. Department of Agriculture, "Rules and Regulations under the Federal Seed Act." All seed shall be furnished in sealed standard containers. Seed which has become wet, moldy, or otherwise damaged prior to seeding, will not be acceptable.

2.3 Mulch shall be any of the materials noted below:

2.3.1 Grain straw or dry hay: Mulch material which contains an excessive quantity of matured seed of noxious weed or other species which would hinder the establishment of desirable vegetation will not be acceptable. Any mulch material which is fresh or excessively brittle or which is in an advanced stage of decomposition as to smother or retard growth of grass will not be acceptable. Asphaltic material to anchor straw mulch shall be thin enough to be blown from spray equipment. It shall be SS-1, RS-1, or RS-2 asphalt emulsion.

2.3.2 Wood cellulose fiber mulch: Wood cellulose fiber mulch for use with the hydraulic application of grass seed and fertilizer shall consist of specially prepared wood cellulose fiber. It shall be processed in such a manner that it will contain no growth or germination inhibiting factors and shall be dyed an appropriate color to facilitate metering of materials. It shall be manufactured in such a manner that after addition and agitation in slurry tanks with fertilizers, grass seeds, water, and any other approved additives, the fibers in the material will become uniformly suspended to form a homogeneous slurry; that when hydraulically sprayed on the ground, the material will form a blotterlike ground cover impregnated uniformly with grass seed; which after application, will allow the absorption of moisture and allow rainfall or mechanical watering to percolate to the underlying soil. Suppliers shall be prepared to certify that laboratory and field testing of their product has been accomplished, and that it meets all of the foregoing requirements based upon such testing. Weight specifications of this material from suppliers, and for all applications, shall refer only to air dry weight of the fiber material. Absolute air dry weight is based on the normal weight standard of the Technical Association of the Pulp and Paper Industry for wood cellulose and is considered equivalent to 10 percent moisture. Each package of the cellulose fiber shall be marked by the manufacturer to show the air dryweight content.

3. GENERAL REQUIREMENTS: The work includes seedbed preparation, fertilizing, seeding and mulching of all areas indicated to be vegetated. The work also includes those areas inside or outside the limits of construction that are disturbed by the Contractor's operation.

4. SEEDBED PREPARATION: Equipment necessary for the proper preparation of the seedbed and for handling and placing of all required materials shall be on hand, in good condition and shall be approved before the work is started.

4.1 Clearing: Prior to or during grading and tillage operations, the ground surface shall be cleared of stumps, stones, roots, cable, wire, grade stakes, and other materials that might hinder proper grading, tillage, seeding, or subsequent maintenance operations.

4.2 Grading: Grades on the area to be treated shall be maintained in a true and even condition. Maintenance shall include any necessary repairs to previously graded areas.

4.3 Tillage: All graded areas shall be thoroughly tilled to a depth of at least 4 inches by plowing, disking, harrowing, or other approved methods until the condition of the soil is acceptable. On sites where soil conditions are such that high clay content and excessive compaction cause difficulty in getting clods and lumps effectively pulverized, the Contractor shall use the rotary tillage machinery, until the mixing of the soil is acceptable and no clods or clumps remain larger than 1-½ inches in diameter. A firm and compact seedbed is required, and after being graded, the seedbed shall be lightly compacted with a land roller, such as a cultipacker, before and after seeding. All tillage operations shall be as near on the contour as is practical but in no instance up and down the slope.

4.4 Topsoiling: The topsoil stockpiled from excavations and stripping shall be uniformly distributed on the designated areas and evenly spread to an average thickness of 4 inches, with a minimum thickness of 3 inches. Prior to placing the topsoil, the subgrade, wherever excessively compacted by traffic or other causes, shall be loosened by disking or by scarifying to a depth of at least 2 inches, to permit bonding to the subgrade. The spreading shall be performed in such a manner that planting can proceed with little additional soil preparation or tillage. Any irregularities in the surface resulting from topsoiling or other operations shall be corrected in order to prevent the formation of depressions where water will stand. Topsoil shall not be placed when the subgrade is frozen, excessively wet, extremely dry, or in a condition otherwise detrimental to the planting or to proper grading.

5. FERTILIZING: The fertilizer shall be uniformly applied at the rate 25 pounds per 1000 square feet to all areas to be vegetated. The fertilizer shall be incorporated into the upper three or four inches of prepared seedbed. This can be done just prior to the last tillage operation or just prior to seeding, but in no case, will it be applied more than 3 days before seeding. Distribution by means of an approved seed drill equipped to sow seed and distribute fertilizer at the same time will be acceptable. When hydroseeding equipment is used for planting operation, fertilizer shall be applied simultaneously with seed using the above rate of application.

6. SEEDING: The Contractor shall make use of approved seeders. When conditions are such, by reason of draught, high winds, excessive moisture, or other factors that satisfactory results are not likely to be obtained, the work shall be stopped, and resumed only when conditions are favorable. If inspection during seeding operation, or after there is a show of green, indicates that strips wider than the space between the rows planted have been left, or other areas skipped, additional seed shall be sown on these areas. Seed shall be sown between 1 March and 1 May or between 1 September and 15 October. Spring seeding shall be at the rate of 100 pounds per acre of the following seed mixture:

<u>Variety</u>	<u>Pounds</u>
KY-31 Fescue	80
Common Bermuda (hulled)	20

Fall seeding shall be at the rate of 100 pounds per acre of the following seed mixture:

<u>Variety</u>	<u>Pounds</u>
KY-31 Fescue	80
Common Bermuda (unhulled)	20

Note: The variety of seeds indicated shall be sown only during the optimum periods specified.

6.1 Broadcast seeding: In areas too confined for the operation of machinery, hand-operated equipment, such as the "Cyclone" seeder, shall be employed. The seed shall be uniformly distributed over the designated areas. Half the seed shall be sown with the sower moving in one direction, and the remainder shall be sown with the sower moving at right angles to the first sowing. In confined areas, the seed shall be covered, but no deeper than 1/4-inch, by means of rakes or other approved hand tools. Broadcast seeding shall not be done during windy weather.

6.2 Slurry seeding: Seed shall be sown with an approved hydro-seeder in combination with fertilizer, or in combination with wood cellulose fiber mulch and fertilizer. Seed shall be uniformly distributed over the areas to be seeded.

6.3 Mechanical power-drawn seeder: Seeding shall be accomplished with a combination grass planter and land packer or pulverizer. The seed shall be planted no deeper than 1/4-inch. The seeding operation should be as near on the contour as is practical, but never up and down the slope. After seeding, the seeded area shall be compacted with a land roller, such as a cultipacker. It will be permissible to sow the seed and cultipack the soil all in one operation if the proper equipment is used.

7. MULCHING: The surface of all seeded areas shall be protected by the application of any of the before-mentioned mulch material unless otherwise specified.

7.1 Straw or hay shall be applied evenly over the seeded area in such a manner that thickness of the mulch is approximately uniform throughout the treated area and sunlight is not completely excluded from penetration to the ground surface. The straw mulch shall be applied at the rate of one and one-half tons per acre.

7.2 Wood cellulose fiber mulch: The application of the wood cellulose fiber mulch shall be with the hydroseeder and shall be accomplished immediately after completion of the final tillage operation. The wood cellulose fiber mulch shall be applied at the rate of 1,000 pounds per acre in combination with water, fertilizer and seed and shall be sprayed over the soil in a uniform coat.

7.3 Anchoring mulch: Straw or hay mulch shall be anchored in place by use of a cut-away rolling flat disk packer or by uniformly spraying the straw with the specified asphalt material at the rate of 0.10 gallon residual asphalt per square yard.

8. PROTECTION: The area shall be protected against foot and vehicular traffic by erecting adequate barricades immediately after seeding is completed, and by placing warning signs of an approved type.

9. ESTABLISHMENT: The Contractor shall be responsible for the proper care of the seeded area during the period when the vegetation is being established. In the event of an erosive rain before an adequate stand of vegetation is established, damaged areas shall be repaired, fertilized, seeded, and mulched wholly at the Contractor's expense. This period shall extend for 30 days after the completion of the mulching.

10. POSTPONEMENT OF SEEDING: If upon completion of the finish grading, the seeding cannot be completed during the specified periods, then the seeding shall be accomplished during the next seeding period specified. Only an amount considered sufficient by the Contracting Officer to cover payment for this work will be withheld from the progress payments. The beneficial occupancy of the facility shall not be delayed by the postponement of the seeding.

---oOo---

Faint, illegible text, possibly bleed-through from the reverse side of the page. The text is mirrored and difficult to decipher.

Faint, illegible text, possibly bleed-through from the reverse side of the page. The text is mirrored and difficult to decipher.

SECTION 03301

CAST-IN-PLACE CONCRETE

1. APPLICABLE PUBLICATIONS: The following publications of the issues listed below, but referred to elsewhere by basic designation only, form a part of this specification to the extent indicated by the references thereto (where a number is suffixed to the specification number, it denotes the effective amendment to the specification):

1.1 Federal and Military Specifications and Standards:

O-C-105C Calcium Chloride, Dihydrate and Calcium Chloride, Anhydrous; Technical.
UU-B-790A Building Paper, Vegetable Fiber; (Kraft, Waterproofed, Water Repellent and Fire Resistant).

1.2 American Concrete Institute (ACI):

ACI 305-72 Recommended Practice for Hot Weather Concreting.
ACI 306-66 Recommended Practice for Cold Weather Concreting.
ACI 318-71 Building Code Requirements for Reinforced Concrete.
ACI 347-68 Recommended Practice for Concrete Formwork.

1.3 American Society for Testing and Materials (ASTM):

A53-73 Welded and Seamless Steel Pipe.
A 185-73 Welded Steel Wire Fabric for Concrete Reinforcement.
A 615-74a Deformed and Plain Billet-Steel Bars for Concrete Reinforcement.
C 31-69 Making and Curing Concrete Compressive and Flexural Strength Test Specimens in the Field.
C 33-74 Concrete Aggregates.
C 39-72 Compressive Strength of Cylindrical Concrete Specimens.
C 94-74 Ready-Mixed Concrete.
C 138-74 Unit Weight, Yield, and Air Content (Gravimetric) of Concrete.
C 143-74 Slump of Portland Cement Concrete.
C 150-74 Portland Cement.
C 172-71 Sampling Fresh Concrete.
C 231-75 Air Content for Freshly Mixed Concrete by the Pressure Method.
C 260-74 Air-Entraining Admixtures for Concrete; Specifications.
C 309-74 Liquid Membrane-Forming Compounds for Curing Concrete.
D 1785-74 Polyvinylchloride (PVC) and chlorinated polyvinylchloride (CPVC) plastic pipe, schedules 40, 80 and 120.

2. QUALITY CONTROL: Approvals, except those required for field installations, field applications, and field tests shall be obtained before custom fabrication is started and before delivery of materials or equipment to the project site. All materials and materials sources shall be approved not less than 30 days prior to their use in the work.

All testing will be conducted by the Contracting Officer, as specified hereinafter; samples shall be furnished by the Contractor as specified hereinafter, and at his expense.

3. SUBMITTALS:

3.1 Certificates: Submit notarized certificates from the manufacturer attesting that the following products conform to all requirements of this specification and of reference documents:

- a. Cement
- b. Aggregates
- c. Admixtures
- d. Reinforcement
- e. Curing materials

3.1.1 Sample Certificate: The notarized certificate shall not contain statements that could be interpreted to imply that the product does not meet all requirements specified, such as "as good as"; "achieve the same end use and results as materials formulated in accordance with the referenced specification"; "equal or exceed the service and performance of the specified material". The certificate should simply state that the product conforms to all requirements specified.

SAMPLE CERTIFICATE

The manufacturer hereby certifies that the following products being furnished for this project conform to all requirements of the project specifications and of the reference specifications listed:

MANUFACTURER AND PRODUCT

John Doe Company
Portland Cement, Type I

REFERENCE SPECIFICATION

ASTM C150-74, Type I.

SIGNATURE AND TITLE

NOTARY STATEMENT AND SEAL

4. PROPORTIONING CONCRETE: The design of the concrete mixture using materials specified herein shall be the responsibility of the Contractor as set forth under Alternate No. 2 of the ASTM C94. The concrete produced shall have the following characteristics:

4.1 Compressive strength at 28 days shall not be less than 3000 pounds per square inch.

4.2 Control: The strength quality of the concrete proposed for use shall be established by tests made in advance of operations.

4.3 Slump shall be not more than 4 inches for vibrated concrete and 5 inches for non-vibrated concrete.

5. AIR-ENTRAINED CONCRETE: Air-entrained concrete shall be provided for all concrete. Air-entrainment shall be accomplished by using an air-entraining admixture. Air-entraining admixtures shall be added in solution in a portion of the mixing water by means of a mechanical batcher in a manner that will insure uniform distribution of the agent throughout the batch. Except as specified otherwise, the air content of freshly mixed air-entrained concrete shall be 5 to 7 percent of the concrete volume. The percentage of air shall be determined by ASTM C 231 on samples of concrete during placing of the concrete in the forms, except that for concrete made with slag aggregate ASTM C 138 shall be used.

6. MATERIALS:

6.1 Cement: Cement shall be Type I or II conforming to ASTM C150.

6.2 Water: Water for mixing and curing, including free moisture and water in the aggregates, shall be fresh, clean and potable.

6.3 Aggregates: Aggregates shall conform to ASTM C33, except as modified herein. Coarse aggregate shall be size no. 57 or 67.

6.4 Admixtures: Admixtures shall be used in the concrete as specified hereinafter. Chemical admixtures shall not be used without the written permission of the Contracting Officer. When more than one admixture is used in a mix, the Contractor shall furnish satisfactory evidence that the admixtures to be used are compatible in combination with the cement and aggregates to be used for the project and will be suitable at the job temperatures. The cost of the admixtures to be used for this project shall be included in the contract bid price.

6.4.1 Air-entraining admixtures conforming to ASTM C 260 shall be used in all concrete specified to be air-entrained.

6.5 Reinforcement:

6.5.1 Reinforcing bars: All reinforcing steel shall be deformed. Reinforcement shall conform to ASTM A615, Grade 40.

6.5.2 Welded wire fabric shall be electrically-welded fabric of cold-drawn wire of gage and mesh size shown on the drawings, and shall conform to ASTM A 185.

6.6 Materials for Curing Concrete:

05-76-6799

03301 - 3

6.6.1 Waterproof paper shall conform to UU-B-790.

6.6.2 Polyethylene sheeting shall be natural color and shall a nominal thickness of 0.004 inch.

6.6.3 Polyethylene-coated burlap shall be 4 mil white opaque polyethylene film impregnated or extruded into one side of the burlap. Burlap shall weigh not less than 9 ounces per square yard.

6.6.4 Liquid membrane-forming compound shall conform to ASTM C 309, white-pigmented Type 2, and be free of paraffin or petroleum.

6.7 Curb pipe drains shall be fabricated from standard weight galvanized steel pipe conforming to ASTM A53, or may be fabricated from Schedule 40 PVC pipe conforming to ASTM D1785.

6.8 Vapor Barrier shall be polyethylene sheeting of 0.006 inch nominal thickness.

7. FORMS:

7.1 General Requirements: Forms shall be provided for all concrete not indicated or specified otherwise. Forms shall be set true to line and grade and maintained so as to insure completed work within the allowable tolerances specified, and shall be mortar-tight. The Contractor shall be responsible for the adequacy of forms and form supports. Bolts and rods used for internal ties shall be arranged so that when the forms are removed, all metal will be not less than 1-1/2 inches from any surface. All forms shall be constructed so that they can be removed without damaging the concrete. All exposed joints, edges, and external corners shall be chamfered a minimum of 3/4-inch unless specified otherwise hereinafter.

7.2 Materials for Forms: Forms shall be of wood, plywood, steel or other suitable material. Wood forms, for surfaces exposed to view in the finished structure and requiring a standard finish, shall be tongue-and-groove boards or plywood. For unexposed surfaces, undressed square-edge lumber may be used. Surfaces of steel forms shall be free from irregularities, dents, and sags.

7.3 Coating: Before placing the concrete, the contact surfaces of forms shall be coated with a non-staining mineral oil or suitable non-staining form coating compound, or shall be given two coats of nitrocellulose lacquer. All excess coating shall be removed by wiping with cloths. Reused forms shall have the contact surfaces cleaned thoroughly; those which have been coated shall be given an additional application of the coating.

7.4 Tolerances and Variations: The Contractor shall set and maintain concrete forms to ensure that, after removal of the forms and prior to patching and finishing, no portion of the concrete work will exceed any of the tolerances specified in ACI 347.

8. VAPOR BARRIER: Vapor barrier shall be provided beneath the entire concrete floor slab of the building over the special compacted fill that is specified under another section. The material shall be placed in the greatest widths and lengths practicable so as to eliminate joints wherever possible; where joints are necessary, the material shall be lapped not less than 6 inches for the side and end laps and sealed with approved adhesive. Torn, punctured, or damaged vapor barrier material shall be removed and replaced as directed, prior to the placing of concrete. Concrete shall be placed in a manner to preclude damage to the vapor barrier material.

9. MEASUREMENT AND MIXING:

9.1 General: Materials shall be measured, batched, and mixed in stationary or truck mixers as specified in ASTM C94. Concrete may be ready-mixed except as modified herein, or may be mixed on the site at the option of the Contractor. Proportioning of materials shall be accomplished by weighing.

9.2 Job Mixed Concrete: Concrete mixed at the job site shall be mixed in an approved type batch mixer in the manner specified for stationary mixers in ASTM C94.

9.3 Ready-mixed concrete: Except for the materials and placing times herein specified, ready-mixed concrete shall be mixed and delivered to the project in accordance with ASTM C94, using Alternate No. 2 for the mix design. With each load of concrete delivered to the project, the ready-mixed concrete producer shall furnish, in duplicate, certification as required by ASTM C94.

10. PLACING REINFORCEMENT AND MISCELLANEOUS MATERIALS:

10.1 General Requirements: All reinforcement shall be provided with all necessary wire ties, chairs, spacers, supports, and other devices necessary to install and secure the reinforcement properly. All reinforcement, when placed, shall be free from flaky rust, scale, oil, grease, clay, and other coatings, and foreign substances that would reduce or destroy the bond. All reinforcement shall be supported and wired together to prevent displacement by construction loads or by the placing of concrete. Unless directed otherwise by the Contracting Officer, reinforcement shall not be bent after being partially embedded in hardened concrete. Where cover over reinforcing steel is not specified it shall be in accordance with ACI 318.

10.2 Placing reinforcement: Reinforcement shall be placed accurately and secured. It shall be supported by suitable chairs or spacers or by metal hangers. On the ground, and where otherwise subject to corrosion, concrete or other suitable non-corrodible material shall be used for supporting reinforcement. Welded wire fabric in slabs shall be supported and adequately secured as required for reinforcing steel.

10.3 Splicing of Reinforcement: Splicing of reinforcement shall be in accordance with ACI 318, except as indicated otherwise or modified herein. Sides and ends of welded wire fabric shall be overlapped not less than one mesh.

10.4 Setting Miscellaneous Materials: Anchors and bolts, including but not limited to those for machine and equipment bases; frames or edgings, hangers and inserts, pipe supports, pipe sleeves, metal ties, conduits, drains, and all other materials in connection with concrete construction; shall, where practicable, be placed and secured in position when the concrete is placed. Anchor bolts for machines shall be set to templates, shall be plumbed carefully and checked for location and elevation with an instrument, and shall be held in position rigidly to prevent displacement while concrete is being placed.

11. CONVEYING AND PLACING CONCRETE:

11.1 Conveying: Concrete shall be deposited as nearly as practicable in its final position in the forms. At any point in the conveying, the free vertical drop of the concrete shall not exceed 3 feet. Conveying equipment shall be cleaned thoroughly before each run. Concrete which has segregated in conveying shall be removed and disposed of as directed by the Contracting Officer.

11.2 Placing: No concrete shall be placed after there is evidence of initial set. The placement of concrete in uncovered areas during periods of precipitation will not be allowed. Placing concrete in water will not be allowed. Subgrades of earth or other material shall be properly prepared and, if necessary, covered with heavy building paper or other suitable material to prevent the concrete from becoming contaminated. Before placing concrete on porous subgrades, they shall be dampened as required to prevent water of hydration from being absorbed into the subgrade. Forms shall be clean of dirt, construction debris, water, snow, and ice. The method of depositing concrete shall be such as to avoid displacing the reinforcement and segregating the aggregate. Concrete shall be worked about the reinforcement and embedded fixtures and into corners and angles of the forms, care being taken to avoid overworking which may result in segregation. Water which accumulates on the surface of the concrete during placing shall be removed by absorption with porous materials in a manner that prevents removal of cement. Pumping of concrete through aluminum pipe shall not be permitted.

11.3 Vibration: All concrete, with the exception of concrete slabs 4 inches or less in depth, shall be compacted with high frequency, internal, mechanical vibrating equipment supplemented by hand spading and tamping. Concrete slabs 4 inches or less in depth shall be consolidated by wood tampers, spading and settling with a heavy leveling straight edge.

11.4 **Embedded Items:** All sleeves, inserts, anchors, and embedded items required for adjoining work or for its support shall be placed prior to concreting. All sub-contractors, whose work is related to the concrete or must be supported by it, shall be given ample notice and opportunity to introduce or furnish embedded items before the concrete is placed. All ferrous metal sleeves, inserts, anchors, and other embedded ferrous items exposed to the weather or where rust would impair the appearance or finish of the structure shall be galvanized. Embedded items shall be positioned accurately and supported against displacement. Voids in sleeves, inserts, and anchor slots shall be filled temporarily with readily removable material to prevent the entry of concrete into the voids. Aluminum shall not be embedded in concrete except where aluminum is protected from direct contact with the concrete.

11.5 **Placing Concrete in Cold Weather:** Placing concrete in cold weather shall be in accordance with ACI 306 except as modified herein. Except when authorized specifically by the Contracting Officer, concrete shall not be placed when the atmospheric temperature is below 40 degrees Fahrenheit. When the concrete is likely to be subjected to freezing temperatures within 24 hours, concrete materials shall be heated, at no additional cost to the Government, so that the temperature of the concrete when deposited shall be between 65 and 80 degrees Fahrenheit. Methods of heating materials shall be subject to approval of the Contracting Officer. Water for mixing shall not be heated above 165 degrees Fahrenheit. Lumps of frozen material and ice shall be removed from the aggregates before placing them in the mixer. When approved by the Contracting Officer, not more than 2 pounds of type I or 1 pound 10 ounces of type II calcium chloride conforming to O-C-105 may be used per bag of cement as an accelerator. No extra payment will be made for the calcium chloride so used. It shall be applied in the mixer drum in the form of a solution; the water in the solution shall be included in the water-cement ratio of the concrete mixture. All other requirements given hereinbefore shall apply when calcium chloride is used. Concrete damaged by freezing shall be removed and replaced at no additional cost to the Government.

11.6 **Placing Concrete in Hot Weather:** Placing concrete in hot weather shall be in accordance with ACI 305 except as modified herein. In hot weather, extra care shall be taken to reduce the temperature of the concrete being placed, and to prevent rapid drying of newly placed concrete. When the outdoor ambient temperature is more than 90 degrees Fahrenheit, the temperature of the concrete as placed shall not exceed 90 degrees Fahrenheit; the fresh concrete shall be shaded as soon as possible after placing; and curing shall be started as soon as the surface of the fresh concrete is sufficiently hard to permit it without damage.

12. SURFACE FINISHES:

12.1 **General Requirements:** All formed surfaces shall be repaired by patching minor honeycombed or otherwise defective areas and tie holes with cement mortar. Cement mortar for patching shall be proportioned one part cement to two parts fine sand. Patching shall be done as soon as the forms are removed; areas of surfaces which are to be cured with a curing compound shall be covered during the application of the compound. All areas to be patched shall be cleaned thoroughly. The area to be patched and at least 6 inches adjacent thereto shall be saturated with water before placing the mortar. Patches on exposed surfaces shall be finished to match the adjoining surfaces. Patches shall be cured as specified for the concrete.

12.2 **Standard Finish:** Standard finish shall be provided for all exposed concrete not indicated or specified otherwise. The surface of the concrete shall not vary more than 1/4 inch when measured from a five-foot template. Exposed surfaces shall be uniform in appearance.

12.2.1 **Against Forms:** All fins and other projections shall be removed carefully, and all abrupt irregularities shall be leveled. Surface pits having a dimension greater than 1/8-inch shall be filled with cement mortar as specified hereinbefore for patching.

12.2.2 **Not Against Forms:** Surfaces not specified otherwise shall be finished with wood floats to even surfaces. Concrete floor slabs shall receive a steel trowel finish. The concrete shall be placed and screeded before bleed water appears on the surface. When the surface has set sufficiently to support a man, it shall be floated to a true plane within 1/4 inch in 10 feet. Upon attaining proper set, the surface shall be troweled to a smooth, dense finish, uniform in texture, and a true plane within 1/8 inch in 10 feet.

13. CURING AND PROTECTION:

13.1 **General Requirements:** Concrete shall be protected adequately from injurious action by sun, rain, flowing water, frost, and mechanical injury, and shall not be allowed to dry out from the time it is placed until the expiration of the minimum curing periods specified hereinafter. Curing shall be accomplished by moist curing, impervious-sheeting curing, or by application of liquid membrane-forming compound. Membrane-forming compound shall not be used on concrete to which other concrete is to be bonded. Completion of curing shall be initiated immediately following the removal of forms. The temperature of the air next to the concrete shall be maintained at not less than 40 degrees Fahrenheit for the full curing periods. When concrete is authorized for placement in temperatures below 40 degrees Fahrenheit, the air in contact with the concrete shall be maintained at a temperature of not less than 50 degrees Fahrenheit for a period of 7 days after placing, or at not less than 70 degrees Fahrenheit for a period of 3 days after placing, and at not less than 40 degrees Fahrenheit for the remainder of the specified curing periods.

Heating of the concrete in place shall be effected by vented heaters or steam coils under canvas covers or by other suitable means. The temperature within enclosures shall not exceed 100 degrees Fahrenheit, and adequate moisture shall be applied to the concrete surface during the heating period to prevent it from drying out. The rate of cooling after the protection period shall be approximately one degree Fahrenheit per hour for the first 24 hours and 2 degrees Fahrenheit per hour thereafter. Concrete shall be protected against freezing for the full curing period specified hereinafter.

13.2 Moist Curing:

13.2.1 Mats: The entire surface of the concrete shall be covered with two thicknesses of wet burlap or other suitable material having high absorptive quality. The material shall be thoroughly wet when applied and shall be kept continuously wet during the time it remains on the slab. Mats shall be left in place not less than 72 hours.

13.2.2 Impervious Sheeting Curing: The entire exposed surface shall be wetted thoroughly with a fine spray of water and then covered with (a) waterproofed paper, (b) polyethylene-bonded waterproof paper sheeting, (c) polyethylene-coated burlap sheeting, or (d) polyethylene sheeting. The curing medium shall remain on the concrete surface to be cured for not less than 7 days.

13.3 Liquid Membrane-Forming Compound Curing: Liquid membrane-forming compound shall be applied over all concrete surfaces. All joint openings except sawed joints shall be sealed at the top by inserting moistened paper or fiber rope, or covering with strips of waterproof material, prior to application of the curing compound, in a manner to prevent the curing compound from entering the joint. Seven days following the placing of the liquid membrane-forming compound shall be considered as the end of the curing period and the basis for determining when joint sealing material will be placed in the joints. The curing compound shall be spray applied in two coats and in strict accordance with the manufacturer's printed instructions.

13.3.1 Protection of Treated Surfaces: Concrete surfaces to which liquid membrane-forming compounds have been applied shall be kept free from all foot and vehicular traffic and all other sources of abrasion for not less than 72 hours. Continuity of the coating shall be maintained for the entire curing period and any damage to the coating during this period shall be repaired immediately.

13.4 Curing Periods: The curing period for all concrete shall be at least 7 days.

13.5 Removal of Forms: Forms shall be removed in a manner which will prevent damage to the concrete. Forms shall not be removed until at least 24 hours after completion of concrete placing.

14. SAMPLING AND TESTING:

14.1 Sampling:

14.1.1 Concrete: Samples of wet concrete shall be collected during each working day as often as required to perform all tests required herein. Test specimens shall be made in accordance with ASTM C31. Sampling fresh concrete shall be in accordance with ASTM C172. Concrete samples shall be of proper size to permit making the required test specimens.

14.2 Testing:

14.2.1 Cement testing: Tests on cement will be waived and mill certificates will be acceptable.

14.2.2 Concrete Testing:

14.2.2.1 Testing consistency of concrete slump shall be determined in accordance with ASTM C 143. Tests shall be made at the beginning of a concrete placement operation and each time test cylinders are made.

14.2.2.2 Compressive Tests: Unless otherwise specified, testing of specimens for compressive strength shall be in accordance with ASTM C 39. Three test specimens shall be made for each set of tests. Tests will be made at 7 and 28 days from time of molding. One specimen shall be tested at 7 days, and the other two at 28 days. When a satisfactory relationship between 7 day and 28 day strengths has been established, the 7 day test results may be used as an indicator of the 28 day strength. Each strength test for 28 day strength shall be the average of the strengths of the two test specimens of a set. The strength level of the concrete will be considered satisfactory if the averages of all sets of three consecutive strength test results equal or exceed the specified 28 day compressive strength, and no individual strength test falls below the required 28 day compressive strength by more than 500 pounds per square inch. Where strength level of concrete falls below the specified limits, the Government may order core samples taken, and tested, at the Contractor's expense. In such event, three core samples for each cylinder test indicating defective concrete shall be taken for further testing. Sampling, testing, and evaluation of drilled cores shall be in accordance with ACI 318, Part 3, Chapter 4. Concrete which is determined to be defective based on the strength acceptance criteria therein shall be removed and replaced with acceptable concrete, at no additional cost to the Government. Frequency of compressive tests on concrete cylinders shall be as follows:

a. Not less than 6 test cylinders for each 150 cubic yards, or fraction thereof, of each class of concrete placed, and

b. Not less than 3 test cylinders for each day for each class of concrete placed that day

c. Space testing so that no more than 3 of the test cylinders are taken from any one batch.

14.2.2.3 Air Content: Air-entrained concrete shall be tested for air content at the same frequency as specified for slump tests.

---o0o---

... the ...
... the ...
... the ...
... the ...
... the ...
... the ...
... the ...
... the ...
... the ...
... the ...

SECTION 13601

PREFABRICATED METAL BUILDINGS

1. APPLICABLE PUBLICATIONS: The following publications of the issues listed below, but referred to thereafter by basic designation only, form a part of this specification to the extent indicated by references thereto.

1.1 Federal Specifications:

HH-I-542 Insulation Felt, Thermal, Mineral Wool (For Low Temperatures).
QQ-S-775D Steel, Sheets, Carbon, Zinc-coated.
RR-D-575B Door, Metal, Siding and Swinging, Door Frame, Metal (Flush and Semi-flush).
TT-C-001796 Calking Compounds, Metal Seam and Wood Seam.
TT-P-645 Primer, Paint, Zinc-chromate, Alkyd Type.

1.2 Military Specifications:

MIL-S-4174B Steel Sheet and Strip, Flat, Aluminum Coated, Low Carbon.
MIL-C-18480A Coating Compound, Bituminous, Solvent, Coal Tar & Am 3 Base.
MIL-P-21035 Paint, High Zinc Duct Content, Galvanizing & Am 1 Repair.
(SHIPS)

1.3 American Institute of Steel Construction (AISC) Publication:

AISC Specification for the Design, Fabrication, and Erection of Structural Steel for Buildings, (Current Issue).

1.4 American Iron and Steel Institute (AISI) Publication:

Light Gage Cold-Formed Steel Design Manual, (Current Issue).

1.5 American National Standards Institute (ANSI):

A156.1-1970 Butts and Hinges (BHMA 101).
A156.2-1975 Locks and Lock Trim (BHMA 601).

1.6 American Society for Testing and Materials (ASTM)
Publications:

A386-73	Zinc Coating (hot-dip) on Assembled Steel Products.
A525-73	General Requirements for Zinc-coated (Galvanized) Steel Sheet by the Hot Dip Process.
E96-66(1972)	Water Vapor Transmission of Materials in Sheet Form.
B117-64	Salt spray (fog) testing.
E96-66	Water vapor transmission of material in sheet form.
D822-60	Operating light and water-exposure apparatus for testing paint, varnish, lacquer and related products.

1.7 American Welding Society (AWS) Publication:

D1.0-69 Code for Welding in Building Construction.

1.8 Metal Building Manufacturers Association (MBMA)
Publication:

Recommended Design Practices Manual, (Current Issue).

2. QUALITY CONTROL: Approvals, except those required for field installations, field applications, and field tests, shall be obtained before delivery of materials or equipment to the project site.

3. SUBMITTALS:

3.1 Shop Drawings: Shop drawings for prefabricated metal buildings and accessories shall be submitted to and approved by the Contracting Officer before work is started. Shop drawings shall indicate anchor bolt plan(s), details of structural framework, structural connections, roofing, siding, fastening system, doors, skylights, other openings, flashing, sealing of joints, and details or diagrams as necessary to augment erection instructions and shall include descriptive data on all materials. Prefabricated metal buildings and accessories shall not be delivered to the site until shop drawings have been approved.

4. DELIVERY AND STORAGE: Prefabricated components, sheets, panels, and other manufactured items shall be delivered and stored in such a manner that they will not be damaged or deformed. Materials shall be stacked on platforms or pallets and covered with tarpaulins or other suitable weathertight ventilated covering. All metal sheets or panels shall be stored so that water which might have accumulated during transit or storage will drain off; the

sheets or panels shall not be stored in contact with materials that might cause staining. Upon arrival on the job site, the sheets or panels shall be inspected; if found wet, the moisture shall be removed and the sheets or panels shall be re-stacked and protected until used.

5. REQUIREMENTS:

5.1 General: Prefabricated metal buildings shall be provided where indicated and shall be the product of a manufacturer who is regularly engaged in manufacture of prefabricated metal buildings. The buildings shall have clear spans. The buildings shall be one of the rigid frame type or the self-framing type.

5.2 Assembly and Disassembly: The size of the prefabricated components and the necessary field connections required for erection shall be such as will permit easy assembly and disassembly by means of the building manufacturer's standard fasteners and construction tools. The maximum size of any shop-assembled component of the buildings shall be such as will permit transportation from factory to site by commercial carrier. Components of the metal buildings shall be fabricated in such manner that once assembled, they may be disassembled, repackaged, and reassembled with a minimum amount of labor and maximum salvageability. Each and every piece and part of the assembly shall be clearly and legibly marked to correspond with previously prepared erection drawings, diagrams, and/or instruction manuals. At least two complete sets of erection drawings, diagrams, or instruction manuals shall be provided with each building. A minimum of five percent excess over the required amount of nuts, bolts, screws, washers, and other required fasteners shall be provided with each building.

5.3 Design: Unless specified otherwise herein, the design of all prefabricated metal buildings shall be in accordance with the MBMA Recommended Design Practices Manual. If required, the Contractor shall submit for approval the engineering design calculations and stress diagrams of all structural or load-bearing components.

5.3.1 Normal Design Loads: The vertical live loads, the applicable dead loads, shall be not less than 20 psf, applied on the horizontal projection of the roof structure. The wind load on the buildings shall be 115 miles per hour proportioned and applied as horizontal and uplift velocity pressures. The maximum deflection in roofing of roof panels shall not exceed 1/180th of the span, and the maximum deflection in siding or wall panels shall not exceed 1/90th of the span.

5.3.2 Auxiliary Loads: Superimposed dynamic and/or static loads shall be applied in addition to the normal design loads and shall be considered in combinations with normal design loads.

6. MATERIALS:

6.1 **Steel Framework:** Steel framework shall be in accordance with the Steel Construction Manual of the AISC. Steel framing less than 3/16-inch thick shall be in accordance with the AISI Light Gage Steel Design Specification. Prefabricated sections of the framework shall be designed to assure easy packing, shipping, erection, dismantling, repacking, and re-erection, and shall be assembled in a manner which will assure the maximum strength and rigidity. Approved structural members, or structural assemblies, having cross-sectional areas and/or connections that differ from the section and connections indicated may be used, if the proposed framework meets design requirements.

6.2 **Siding and Roofing:** Siding and roofing (sheets or panels) shall be either steel or aluminum conforming to the following requirements. As far as practical, one type of siding and one type of roofing shall be used throughout the project.

6.2.1 Steel sheets or panels shall be either zinc-coated or aluminum-coated. Zinc-coating for steel shall conform to the requirements of QQ-S-775, class d. Aluminum-coated steel shall conform to the applicable requirements of MIL-S-4174, type II. The siding or panels shall be either the deep corrugated type, or the panel type. The deep corrugated type shall have corrugations, V-beams, ribs, channels, or other similar configurations not less than one inch deep spaced not to exceed 12 inches on centers or not less than 3/4-inch deep spaced not to exceed 6 inches on centers. The panel type shall have either interlocking ribs not less than 3 inches deep spaced not greater than 16 inches apart, or configurations not less than 1-1/2 inches deep spaced not greater than 12 inches apart.

6.2.2 Aluminum sheets or panels shall be manufactured from alloy 3003 alclad or 3004 alclad and shall be tempered as required to suit the respective forming operations. The minimum thickness shall be 0.032-inch (20 B&S gage). The sheets or panels shall be either the deep corrugated type, or the panel type. The deep corrugated type shall have corrugations, ribs, V-beams, channels, or other similar configurations not less than one inch deep spaced not to exceed 12 inches on centers or not less than 3/4-inch deep spaced not to exceed 6 inches on centers. The panel type shall have either interlocking ribs not less than 3 inches deep, spaced not greater than 16 inches apart, or configurations not less than 1-1/2 inches deep, spaced not greater than 12 inches apart.

6.2.3 Skylight panels shall be of such configuration to be used interchangeably with and of the same size as roofing panels. Panels shall be corrugated, fiberglass reinforced, polyesteracrylic panels weighting not less than 8 ounces per square foot. Glass reinforcement shall be not less than 27 percent by weight. Corrugations shall be standard to match the metal roofing provided. Surface shall be smooth, color as selected.

6.2.4 **Fasteners for Securing Sheets and Panels:** Fasteners for attachment to structural supports and fasteners for attachment to adjoining sheets or panels shall be as approved, and in accordance with the manufacturer's recommendation. Unless specified otherwise

herein, the fasteners shall be either self-tapping screws, bolts and nuts, self-locking rivets, self-locking bolts, end-welded studs, bolted or riveted studs, or step rivets held by aluminum straps. Other types of fasteners of the building manufacturer's standard type may be used if prior approval is obtained. The fastening system shall be designed to withstand the design loads specified herein. Fasteners shall be stainless steel, cadmium-plated steel, or aluminum. All fasteners, with the exception of those having integral Hex washer heads and those having aluminum drive caps, shall have composit metal and polymerized chloroprene washers. Fasteners having integral Hex washer heads and fasteners having aluminum drive caps shall have polymerized chloroprene washers. Side laps of roofing sheets or panels having configurations 3/4-inch deep, or less, shall be fastened at a maximum spacing of 12 inches on centers.

6.3 Sheet Metal Accessories: As far as practical, zinc-coated steel accessories shall be provided with zinc-coated siding or roofing, and aluminum accessories shall be provided with aluminum alloy siding or roofing. Zinc-coating for all sheet steel accessories shall conform to QQ-S-775, class d. All aluminum accessories shall be of the alloy and temper necessary to suit forming requirements.

6.3.1 Strips and Plates: Eave and edge strips, fascia strips, miscellaneous flashings, and miscellaneous sheet metal accessories, unless specified otherwise, shall be formed from the same material and gage as the roof covering. Wall plates, base angles or base channels, and other miscellaneous framing members may be standard structural steel shapes, or they may be formed from steel not lighter than 16 gage.

6.4 Miscellaneous Accessories:

6.4.1 Closure strips shall be formed of approved compressed rubber, synthetic rubber, bituminous impregnated materials, or metal of the same respective types as the roofing and siding, and as standard with the manufacturer. Molded closure strips shall be free of open voids and shall not absorb or retain water. Closure strips shall be formed to match the corrugations or configurations of the roofing or siding being used and shall be provided where indicated and where necessary to provide weathertight construction.

6.4.2 Joint Sealing Material: All side and end laps shall be sealed with Type II, Class B ribbon form sealant conforming to IT-C-001796. Minimum sizes of ribbons shall be 3/32-inch by 1/2-inch for rectangular areas and 1/4-inch diameter for circular areas. All joints at doors, windows, accessories, and flashings shall be sealed in a manner similar to the sealing of sheets and panels. Bituminous type sealing materials shall not be used with painted sheets and panels.

6.5 Hollow Metal **Doors** and Door Frames: All hollow metal doors shall conform to **the** applicable requirements of RR-D-575, except as specified otherwise herein. Doors and frames shall be of the sizes and in the locations indicated.

6.5.1 Frames for Hinged Doors: Hollow pressed steel frames shall be the full welded type or the knock-down field-assembled type. The frames shall be of a type standard with the metal building manufacturer and shall be constructed to be coupled or interlocked with the adjoining wall covering material in an approved manner. The edges of the wall covering material at the sides of the frames shall be reinforced as necessary to form a connection of strength and rigidity which adequately meets design requirements. Lintels above door frames shall be contoured to serve as combination framing and flashing. Doors and frames may be shipped as a part of a prefabricated wall section, or may be packaged separately for fabrication at the site. Approved structural steel frames may be provided in lieu of pressed steel frames, if such construction is standard with the metal building manufacturer.

6.5.2 Hollow metal hinged doors shall be type III, Extra Heavy Duty, designed for exterior use.

6.5.3 Hardware for Hinged Doors: All hardware shall, as far as practicable, be of one manufacturer's make. Hardware for application on metal shall be made to standard templates. Each door shall be provided with 3 hinges, A2112, 4 1/2 by 4 1/2 inches, BHMA finish Code 612, conforming to ANSI A156.1 and 1 lockset, series 4000, F81, BHMA finish Code 612, conforming to ANSI A156.2.

6.6 Shop Painting: All ferrous metal work, except zinc-coated work, aluminum-coated work, and work specified herein to be factory finished, shall be (1) cleaned of all dirt, rust, scale, loose particles, grease, oil, and other deleterious substances, (2) given a coat of pretreatment primer conforming to MIL-P-15328 applied to a dry film thickness of 0.3 to 0.5 mil or chemically treated with a phosphoric type cleaner, and (3) then be given one coat of an approved rust-inhibiting primer paint of the type standard with the metal building manufacturer.

6.7 Dissimilar Materials: Where aluminum surfaces come in contact with ferrous metal or other incompatible metals, the aluminum surfaces shall be kept from direct contact by one of the following methods:

- (a) Painting the incompatible metal with a coating of heavy-bodied bituminous paint conforming to MIL-C-18480;
- (b) Painting the incompatible metal with a prime coat of zinc-chromate primer conforming to TT-P-645, followed by one or two coats of aluminum metal-and-masonry paint, or other suitable protective coating, excluding those containing lead pigmentation;
- (c) An approved nonabsorptive gasket;
- (d) An approved calking placed between the aluminum and the incompatible metal.

6.7.1 Factory finishing: Exterior and interior exposed surfaces of metal roofing, metal siding, doors, door frames, and metal accessories shall be provided with a factory applied baked on enamel finish. The finish shall consist of cleaning, pretreatment with a chemical conversion coating and one coat of baked on synthetic

enamel applied to a dry film thickness of not less than 1 mil; color shall be as selected. The type of sheets being furnished shall have been tested and have passed the following tests:

- (a) Salt-spray test: A 12-inch by 12-inch sample of the siding and roofing, with a minimum of two raw cut edges, shall withstand a salt-spray test for a minimum of 500 hours in accordance with ASTM B117. Undercutting of the paint film from the score line shall not exceed 1/16 inch.
- (b) Accelerated weathering test: A 12-inch by 12-inch sample with a minimum of two raw cut edges shall withstand a weathering test a minimum of 1,000 hours in accordance with ASTM 822 without checking, cracking or loss of adhesion.
- (c) Flexibility: When formed over a conical mandrel, the film shall show no crack beyond a point where the mandrel diameter is equal to five times the metal thickness.
- (d) Adhesion: There shall be no film removed by pulling off sharply No. 600, 3/4 inch wide scotch cellophane tape applied to 10 parallel cuts spaced 1/16-inch apart plus 10 similar cuts at right angles. Cuts shall be made with a sharp knife.

6.8 Thermal Insulation: Thermal insulation shall be provided under all roof and wall panels. Insulation shall be either the flexible (blanket) type or the semi-rigid type as standard with the metal building manufacturer and shall have a factory-applied facing on one side. The insulation shall conform to the applicable requirements of HH-I-542, except as specified otherwise herein. Facing on insulation shall be vinyl-scrim-foil or 0.002-inch aluminum foil. Facing on flexible (blanket) type insulation shall have 2-inch tabs along both edges; facing on semi-rigid type insulation shall have 2-inch tabs along one edge or shall be sealed with 4-inch tape.

6.8.1 Thermal Value: Roof and wall insulation shall have a "R" factor of 7 or more.

6.8.2 Flame Spread and Smoke Developed Ratings: The assembly of insulation and its facing shall have a flame spread rating not greater than 25 and a smoke developed rating not greater than 50 when tested in accordance with ASTM E84. Insulation bearing the UL label or listed by Underwriters' Laboratories as meeting the requirements will be accepted in lieu of certified copies of test reports.

6.8.3 Permeance Rating: The insulation facing shall serve as a vapor barrier and shall have a permeance rating of 0.05 perm or less when tested in accordance with ASTM Test E96.

7. **INSPECTION:** Prior to starting installation of any steel floor units and accessories, the worksite shall be inspected to verify that the as built structure will permit the indicated field installation of the steel floor unit system without modification.

8. **ERECTION:**

8.1 **General:** Concrete foundations and floor slabs shall be level and true, and shall be inspected and approved before the structural steel work is started. Anchor bolts shall be installed while the concrete work is in progress; templates or other gaging devices shall be used to assure accurate spacing of the anchor bolts. Defects or errors in the fabrication of building components shall be corrected by the Contractor in an approved manner. Defects or errors in fabrication of components, which can not be corrected in an approved manner, shall be replaced by nondefective members at no additional cost to the Government. Columns, rigid frames, and walls of self-framing buildings shall be plumbed in both directions, guyed and stayed, and all framing elements shall be accurately spaced to assure the proper fitting of prefabricated wall and roof coverings.

8.2 **Rigid Frames, Column Bases, and Sill Members:** Rigid frames, column bases, and sill members shall be set accurately, using a non-shrinking grouting mortar to obtain uniform bearing on the concrete and to maintain a level base line elevation. Anchors and anchor bolts for securing rigid frames, columns, or sill members to foundations shall be steel, unpainted, set accurately to templates, and of proper size to adequately resist all applicable design loads at the base. Grouting mortar shall be a mixture of one part of blended portland cement, to two parts of well-graded fine aggregate, and enough water to provide a maximum water cement ratio of 0.50. The blended portland cement shall be a mixture of cement with 1/4 ounce of aluminum powder to each sack of cement. Surfaces to receive the mortar shall be clean and moistened thoroughly immediately before placement of mortar. Exposed surfaces of mortar shall be water cured with wet burlap for not less than 7 days.

8.3 **Wall Construction:** All sheets or panels shall be applied with the corrugations, V-beams, ribs, channels, or other configurations in a vertical position. Sheets or panels shall be supplied in full wall heights from base to eave with no horizontal joints except at the junctions of door frames and similar locations. All side and end laps shall be sealed with the joint sealing material specified herein. All walls shall be flashed and/or sealed at the base, at the top, around doors and all other similar openings. The placement of closure strips, flashing and sealing material shall be accomplished in an approved manner that will assure complete weathertightness. Flashing will not be required where approved "self-flashing" sheets or panels are used. Minimum end laps for all types of sheets or panels shall be 2-1/2 inches. Minimum side laps for all types of sheets or panels shall be one corrugation or one configuration.

8.4 Roof Construction: All roofing sheets or panels shall be applied with the corrugations, ribs, channels, or other configurations parallel to the slope of the roof. The full lengths from ridge to eaves with no transverse joints. All side laps shall be laid away from the prevailing wind, and all side and end laps shall be sealed with the joint sealing material specified herein. The roof shall be flashed and sealed at the eaves and rakes, at projections through the roof, and elsewhere as necessary. The placement of closure strips, flashing, and sealing material shall be accomplished in an approved manner that will assure complete weathertightness.

8.5 Installation of Insulation: Roof insulation shall be installed over purlin before roofing sheets or panels are applied. Wall insulation shall be installed between girts and siding sheets or panels. Insulation shall be held rigid until secured in place. Facing shall be exposed on the interior side of the building(s). Facing tabs of flexible (blanket) type insulation shall be folded and stapled on 6-inch centers to completely seal joints. If folding and stapling is accomplished from the inside, the tabs shall be pushed neatly up between the edges of adjoining blankets. Facing tabs of semi-rigid type insulation, which does not have tabs, shall extend the full width of the insulation, and joints between sheets shall be sealed with 4-inch wide tape made of the same material as the facing material. The adhesive used to seal tabs or tape of semi-rigid type insulation shall be fire-resistant and moistureproof. Insulation in self-framing shall be installed in accordance with the manufacturer's recommendations.

---000---

Faint, illegible text at the top of the page, possibly a header or introductory paragraph.

Main body of faint, illegible text, appearing to be several paragraphs of a document.

SECTION 15011

GENERAL REQUIREMENTS, MECHANICAL

1. **APPLICATION:** This section applies to sections 15201, 15221, and 15272 of this project except as specified otherwise in the individual sections.

2. **QUALITY CONTROL:** Approvals, except those required for field installations, field applications, and field tests, shall be obtained before custom fabrication is started and before delivery of material or equipment to the project site.

3. SUBMITTALS:

3.1 **Manufacturer's Data:** After award of contract and before executing any work, seven copies of information in one completely marked and coordinated package sufficient to assure full compliance with the contract requirements shall be submitted for approval. Piecemeal submittal of data is not acceptable and such submittal will be returned without review. Information shall be submitted for all material and equipment the Contractor proposes to furnish for accomplishment of the contract work. Submittals for each manufactured item shall be manufacturer's descriptive literature, equipment drawings, diagrams, performance and characteristic curves, and catalog cuts, and shall include the manufacturer's name, trade name, catalog model or number, nameplate data, size, layout dimensions, capacity, specification reference, applicable Federal and Military specification references, and all other information necessary to establish contract compliance.

3.2 **Shop Drawings:** After award of contract, seven copies of consolidated shop drawings in one complete package shall be submitted for approval. The drawings shall be drawn to a minimum scale of 1/4-inch equals one foot; shall be a minimum of 8 1/2 inches by 11 inches in size; and shall include plans, elevations, and sections of equipment and control spaces identifying and indicating proposed location, layout, and arrangement of items of equipment, control panels, accessories, piping, and any other items that must be shown to assure a coordinated installation. Drawings also shall indicate adequate clearance for operation, maintenance, and replacement of operating equipment devices. If any equipment is disapproved, drawings shall be revised to show acceptable equipment resubmitted. Piecemeal submittal of drawings or marked-up contract drawings or copies are not acceptable and such submittals will be returned without review.

3.3 **Standards Compliance:** Where equipment or materials are specified to conform to requirements of the standards of organizations such as American Society for Mechanical Engineers (ASME), Underwriters Laboratories (UL), American Gas Association (AGA), and American Refrigeration Institute (ARI), that use a label

or listing as method of indicating compliance, proof of such conformance shall be submitted and approved. The label or listing of the specified organization will be acceptable evidence. In lieu of the label or listing, the Contractor shall submit a notarized certificate from an independent testing organization adequately equipped and competent to perform such services, and approved by the Contracting Officer, stating that the item has been tested in accordance with the specified organization's test methods and that the item conforms to the specified organization's standard or code. For materials whose compliance with organizational standards or specifications is not regulated by an organization using its own listing or label as proof of compliance, a notarized certificate from the manufacturer shall be furnished to the Contracting Officer stating that the material complies with the applicable referenced standard or specification.

3.3.1 Materials Tests and Test Reports: The testing requirements for materials incorporated in referenced documents will be waived provided the manufacturer submits notarized certificates stating that previously manufactured materials have been tested by recognized laboratories, that such materials meet testing requirements specified, and that the materials furnished for this project are of the same type, quality, manufacture and make as that tested. Copies of the test reports need not be submitted except as specifically requested by the Contracting Officer.

3.3.2 Sample Certificate: The notarized certificate shall not contain statements that could be interpreted to imply that the product does not meet all requirements specified, such as "as good as"; "achieve the same end use and results as materials formulated in accordance with the referenced specification"; "equal or exceed the service and performance of the specified material". The certificate should simply state that the product conforms to all requirements specified.

SAMPLE CERTIFICATE

The manufacturer hereby certifies that the following products being furnished for this project conform to all requirements of the project specifications and of the reference specifications listed:

MANUFACTURER AND PRODUCT	REFERENCE SPECIFICATION
John Doe Company Portland Cement, Type I	ASTM C150-74, Type I.

SIGNATURE AND TITLE

NOTARY STATEMENT AND SEAL

3.4 Operation and Maintenance Manual: An operation and maintenance manual for each mechanical system, except as otherwise specified herein, and for each piece of equipment shall be furnished

by the Contractor. Manuals for the system as a whole will not be required for outside water distribution systems. Seven copies of the manual bound in hardback binders or an approved equivalent shall be provided to the Contracting Officer. One complete manual shall be furnished prior to the time that system or equipment tests are performed, and the remaining manuals shall be furnished before the contract is completed. The following identification shall be inscribed on the cover: the words "OPERATING AND MAINTENANCE MANUAL," the name and location of the building and the name of the Contractor, and the contract number. The manual shall include the names, addresses, and telephone numbers of each subcontractor installing equipment and systems and of the local representatives for each item of equipment and each system. The manual shall have a table of contents and be assembled to conform to the table of contents with the tab sheets placed before instructions covering the subject. The instruction sheets shall be legible and easily read, with large sheets of drawings folded in. The manual shall include, but not be limited to, the following: a system layout showing piping, valves, and controls; wiring and control diagrams with data to explain detailed operation and control of each component; a control sequence describing start-up, operation and shut-down; a detailed description of the function of each principal component of the system; the procedure for starting; the procedure for operating; shut-down instructions; installation instructions; maintenance and overhaul instructions; lubrication schedule including type, grade, temperature range, and frequency; safety precautions, diagrams, and illustrations; test procedures; performance data; and parts lists. The parts lists for equipment shall indicate the sources of supply, recommended spare parts, and the service organization which is reasonably convenient to the building site. The manual shall be complete in all respects for all equipment, controls, accessories, and associated appurtenances provided.

3.5 Posted Operating Instructions: Operating instructions approved by the Contracting Officer shall be provided for each system and each principal piece of equipment for the use of operation and maintenance personnel. The operating instructions shall include wiring and control diagrams showing the complete layout of the entire system, including equipment, piping, and valves, and control sequence and shall be framed under glass or in approved laminated plastic and posted where directed by the Contracting Officer; printed or engraved operating instructions for each principal piece of equipment including start up, proper adjustment, operation, lubrication, shut-down, safety precautions, procedure in the event of equipment failure, and any other necessary items of instruction as recommended by the manufacturer of the unit shall be attached to or posted adjacent to the piece of equipment. Operating instructions exposed to the weather shall be made of weather-resisting materials or shall be suitably enclosed to be weather protected. Operating instructions shall not fade when exposed to sunlight and shall be secured to prevent easy removal or peeling.

4. INSTRUCTION TO GOVERNMENT PERSONNEL: When specified in other sections, the Contractor shall furnish, without additional expense to the Government, the services of competent instructors who

will give full instruction to the designated personnel in the adjustment, operation, and maintenance, including pertinent safety requirements, of the equipment or system specified. Each instructor shall be thoroughly familiar with all parts of the installation and shall be trained in operating theory as well as practical operation and maintenance work. Instruction shall be given during the first regular work week after the equipment or system has been accepted and turned over to the Government for regular operation. The number of man-days (eight-hours) of instruction furnished shall be as specified in other sections. When more than four man-days of instruction are specified, approximately half of the time shall be used for classroom instruction. All other time shall be used for instruction with the equipment or system. When significant changes or modifications in the equipment or system are made under the terms of the contract, additional instruction shall be provided to acquaint the operating personnel with the changes or modifications.

5. DELIVERY AND STORAGE: Equipment and materials shall be properly stored and adequately protected and carefully handled to prevent damage before and during installation. Equipment and materials shall be handled, stored, and protected in accordance with the manufacturer's recommendations and as approved by the Contracting Officer. Damaged or defective items, in the opinion of the Contracting Officer, shall be replaced at no cost to the Government.

6. CATALOG PRODUCTS: Materials and equipment shall be essentially the standard cataloged products of manufacturers regularly engaged in production of such materials or equipment and shall be manufacturer's latest design that complies with the specification requirements. Materials and equipment shall essentially duplicate items that have been in satisfactory commercial or industrial use at least two years prior to bid opening. Where two units of the same class of equipment are required, these units shall be products of a single manufacturer; however, the component parts of the system need not be the products of the same manufacturer. Each item of equipment shall have the manufacturer's name and address, and the model and serial number on a nameplate securely affixed in a conspicuous place; the nameplate of the distributing agent will not be acceptable.

7. SAFETY REQUIREMENTS: Belts, pulleys, chains, gears, couplings, projecting setscrews, keys, and other rotating parts located so that any person can come in close proximity thereto shall be fully enclosed or properly guarded. High-temperature equipment and piping so located as to endanger personnel or create a fire hazard shall be properly guarded or covered with insulation of a type as specified herein.

8. MANUFACTURER'S RECOMMENDATIONS: Where installation procedures or any part thereof are required to be in accordance with the recommendations of the manufacturer of the material being installed, printed copies of these recommendations shall be furnished to the Contracting Officer prior to installation. Installation of the item will not be allowed to proceed until the recommendations are received. Failure to furnish these

recommendations can be cause for rejection of the material.

9. **ELECTRICAL REQUIREMENTS:** Electrical components of mechanical equipment and systems such as motors, starters, and controls shall be provided under the section covering such mechanical equipment, and shall be as specified herein and as necessary for complete and operable systems. Extended voltage range motors will not be permitted. Interconnecting wiring for components of packaged equipment shall be provided as an integral part of the equipment. All interconnecting power wiring and conduit for field erected equipment and all control wiring rated over 100 volts and conduit shall be as specified in the section entitled "Interior Electrical Systems". Control wiring rated under 100 volts and conduit shall be as specified in the section covering mechanical equipment. Motor control equipment forming part of motor control centers or switchgear assemblies and all necessary conduit and wiring connecting such assemblies, centers, or other power sources to mechanical equipment shall conform to the section entitled "Interior Electrical Systems".

---o0o---

...we can ... for ... the ...

... ...

... ...

... ...

... ...

... ...

... ...

... ...

... ...

... ...

... ...

... ...

... ...

... ...

... ...

... ...

... ...

... ...

... ...

... ...

... ...

... ...

... ...

... ...

... ...

... ...

... ...

... ...

... ...

... ...

... ...

... ...

... ...

... ...

... ...

... ...

... ...

... ...

... ...

... ...

... ...

... ...

... ...

... ...

... ...

... ...

... ...

... ...

... ...

... ...

... ...

... ...

SECTION 15201. WELLS

1. APPLICABLE PUBLICATIONS: The following publications of the issues listed below, but referred to elsewhere by basic designation only, form a part of this specification to the extent indicated by the references thereto (where a number in parenthesis is suffixed to the specification number, it denotes the effective amendment to the specification):

1.1 Federal Specifications:

GG-G-76C(1) Gages, pressure and vacuum, dial indicating.

1.2 American Water Works Association (AWWA):

A100-66 Deep wells.
C601-68 Disinfecting water mains.

1.3 American Society for Testing and Materials (ASTM):

A120-73 Black and hot dipped zinc-coated (galvanized) welded and seamless steel pipe for ordinary uses.
B88-76 Seamless copper water tube.
C150-74 Portland cement.

2. GENERAL REQUIREMENTS: Section 15011, General Requirements, Mechanical, also applies to this section except as otherwise specified. The work includes the provision of four new permanent gravel wall wells at the locations of the new well houses shown, and incidental related work. Each well shall have a minimum capacity of 250 gallons per minute. Each well shall be guaranteed by the Contractor to furnish a continuous supply of clear potable water, completely free of sand conforming to the limits specified hereinafter, of not less than the specified quantities for a period of one year after acceptance of the completed work. A test well shall be drilled at each location of a new well. Should the data obtained from any test well indicate unfavorable conditions, exploration shall be continued at other locations approved by the Contracting Officer until a suitable site is located. All materials and workmanship shall conform to AWWA A100, except as specified or indicated otherwise. All exploration shall be at the expense of the Contractor.

3. SUBMITTALS REQUIRED: Shop drawings, manufacturer's data and certificates for equipment, materials, finish, and pertinent details for each system shall be submitted and approved before procurement, fabrication or delivery of such items to the job site. Partial submission will not be acceptable. Descriptive data shall be annotated to show the specific model, type and size of each item the Contractor proposes to furnish. The submittal requirements of Section 15011, General Requirements, Mechanical, applies to the following lists.

3.1 Manufacturer's Data:

- (a) Well casings
- (b) Well screens

3.2 Shop Drawings:

- (a) Well casings, screens, and air lines

3.3 Certificates: Submit notarized certificates from the manufacturer attesting that each of the following items conform to all requirements of this specification and of reference publications.

- (a) Well casings
- (b) Well screens
- (c) Air lines
- (d) Gages
- (e) Cement

3.4 Samples: Submit one sample of each of the following items:

- (a) Gravel (50 lb. sample)

4. DELIVERY, STORAGE, AND PROTECTION: Materials shall be delivered to the site in an undamaged condition. Materials shall be carefully stored off the ground to provide proper protection against oxidation caused by ground contact. Defective or damaged materials shall be replaced by the Contractor at no expense to the Government.

5. MATERIALS:

5.1 Casings: The outer pit casing 18 inch nominal diameter shall be black steel pipe, 0.375-inch wall thickness, conforming to ASTM A120. All other casings shall be seamless zinc-coated steel pipe conforming to ASTM A120, and shall be not less than 8 inches diameter and not less than 0.322-inch wall thickness. All joints shall be either threaded or coupled, with heavy recessed type couplings in which the ends of the pipe shall butt, or they may be field welded.

5.2 Well Screen: Shall have an inside diameter of not less than 8 inches and be of not less than 6 gauge material, and shall be of AISI Type 304 stainless steel with continuous slot openings of proper size and design to hold back and support the gravel used in the gravel envelope around the screens. Joints shall be made with heavy butt type couplings of the same materials, or by welding. Length shall be as required to provide the amount of water specified. Water velocity thru the slots shall not exceed 0.20 feet per second.

5.3 Gravel: All gravel used for the gravel envelope around screens shall be round, hard, water worn, gravel of proper gradation that will allow free flow of water in the well and positively prevent the infiltration of sand. It shall be of siliceous material, reasonably smooth and round, and shall be free of flat or elongated pieces, as well as of dirt, vegetable matter, or other foreign material. The gravel shall be thoroughly sterilized with hypochlorite before being placed.

5.4 Grout: Cement grout for sealing the space between the casing and the drilled hole, shall be composed of portland cement, type 1, conforming to ASTM C150, and water. The mixed grout shall weigh not less than 14 pounds per gallon.

5.5 Air Lines: Each well shall be provided with an air line. The pipe shall be 1/2 inch copper tubing conforming to ASTM B88, Type K, with solder joint wrought copper fittings. Air line shall extend a minimum of 10 feet below the drawdown level.

5.6 Gages: Gages shall conform to GG-G-76, Class 1, Style A, Type 1, with 4 1/2-inch dial, brass case, bronze tube, and scale calibrated in feet of water.

5.7 Auxiliary Equipment: The Contractor shall provide the necessary discharge piping to dispose of pumped water during developing and testing of well of sufficient distance from each well so as to prevent flooding of the site and flow back into the well.

6. TEST WELLS: The Contractor shall drill a test well at each site before construction of the permanent well is started. Each test well shall be of sufficient size to obtain the necessary information required for the construction of the permanent well, but shall be not less than 6 inches. The location, size of well, and method of drilling must be approved before work is started. Test wells shall be not less than 200 feet deep. The Contractor shall keep an accurate log and record of all material drilled through and the depths at which changes in formation occur. Permanent wells shall not be driven until all data submitted for test wells has been analysed and approved by the Contracting Officer. Test wells may be incorporated into the finished construction provided they meet the requirements for finished wells. Wells not used in finished construction shall be sealed as recommended in AWWA A100.

6.1 Samples: Samples of the type of material found in each stratum shall be taken by the Contractor and preserved in approved containers furnished by the Contractor. Samples shall be appropriately labeled to show depth below ground surface and thickness of the stratum from which the samples were obtained. All water bearing strata must be described in detail as to whether material is loose or compact, its color, and if gravel, whether it is water worn or angular. The presence of clay must be noted.

6.2 Water Quality Determination: The Contractor shall collect and have analysed samples of water from all water bearing strata encountered so as to accurately show the quality of water from each stratum. These preliminary tests shall show in P.P.M. the phenolphthalein alkalinity, total alkalinity, calcium, magnesium, chlorides, carbon dioxide, carbonates, sulfides, bicarbonates, iron manganese, hardness, turbidity, odor and PH.

6.3 Electric Log: A complete electric log indicating resistivity and potential of all formations shall be furnished.

6.4 Recommendation and Data Submittal: The Contractor shall make recommendations for the permanent wells and shall submit all data obtained at each site. The recommendations shall include the appropriate depth, details of construction, length and location of screens, screen openings, and an estimation of the quantity of water that can be obtained from each water bearing stratum and from each completed well.

7. CONSTRUCTION OF PERMANENT GRAVEL WALL WELLS:

7.1 Pit Casing: A hole not less than 24 inches in diameter shall be drilled to a minimum depth of 50 feet and to additional depth as necessary to terminate in an impervious stratum. A pit or surface casing 18 inches in diameter shall be installed concentrically in the hole and extending to 6 inches from the bottom. The pit casing shall be grouted in by pumping a cement slurry around the casing in such manner as to completely fill the hole and seal the casing to the wall of the formation drilled. Before pumping cement, clear water shall be pumped to the bottom of the casing to clear the hole of slush and cuttings. The cement seal formed in the bottom of the casing shall be cut through for further drilling in a manner that will not disturb the seal.

7.2 Drilling: The drilling hole shall be a minimum of 17 inches in diameter and shall extend to the bottom of the lowest water bearing formation as determined from the formation samples and the electric log. Each water bearing formation to be developed shall be under-reamed to at least 22 inches in diameter and hold open for placing of gravel after screens and inner casing has been set. All drilling shall be accomplished with proper drilling clay of the bentonite type having a weight not to exceed 9 pounds per gallon at 15 centipoise viscosity. The ph value of the drilling mud shall be maintained at 7.6 or more at all times. The drilling clay shall be of a type readily thinned with commercial mud thinners for easy removal from the walls of the wells and introduced gravel. Sufficient screens shall be provided at each formation to be developed to secure therefrom all available flow. The depth of the well and quantity of screen used shall be adequate to produce the specified guaranteed capacity. Casing and screens, as specified, shall be installed concentrically in the hole and completely enveloped by gravel and permanently sealed at the lower end. The gravel shall be pumped into place under

pressure, through a temporary pipe line, extending to the bottom of the screen. The pipe line shall be raised as the gravel fills the hole, so that the lower end of the pipe is always 2 to 6 feet below the gravel level. The gravel shall entirely fill the space around the screens and casing, and equipment and methods for placing the gravel shall be approved as adequate to accomplish the result before placement is begun. When the placement of gravel is completed, the drilling clay shall be thinned and the well pumped free of all sand, mud, drillings, and other foreign matter. The gravel shall extend from the bottom to a minimum of 10 feet above the top screen. The remaining annular space around the casing shall be filled with earth in 12 inch layers and each layer thoroughly tamped.

7.3 Tests: Upon completion of each permanent well, the Contractor shall provide a temporary pump in each well for measuring the flow and drawdown. The temporary pump shall have a capacity of not less than 500 gallons per minute. After determining the static water level in the well, the pumping shall begin at a rate of approximately 100 gallons per minute and the drawdown checked at 15 minute intervals until it stabilizes, after which pumping shall be continued at that rate for 2 hours and the water level checked at 30 minute intervals. The pumping rate shall then be increased in uniform increments not exceeding 50 gallons per minute and the described procedure repeated at each increment of increased rate until the capacity of the well is determined. The capacity of the well shall be the flow obtained at a drawdown level 10 feet above the top of the uppermost screen. After the safe maximum yield of the well has been determined, continuous 24 hour pumping test shall be conducted at that rate and the drawdown checked at hourly intervals. The Contractor shall provide necessary pipe and ditches to take the water away from each well site. A complete written log of the test showing static water level, pumping rate and drawdown at the specified intervals shall be furnished. At the end of the 24 hour test, water samples shall be taken and tested by an approved testing laboratory for complete chemical and bacteriological analysis. Additional samples shall be furnished in suitable containers.

7.4 Disinfection: Well and equipment and material therein shall be disinfected in accordance with AWWA A100. Discharge piping shall be disinfected in accordance with AWWA C601.

8. ABANDONING EXISTING WELLS: Existing wells shall be abandoned and sealed in accordance with AWWA A100 and as shown on the drawings.

9. DISPOSAL OF SOIL: Soil removed at drilled holes shall be removed from the sites, and disposed of as specified in the section entitled "Earthwork".

---oOo---

...the first of the ...
...the first of the ...
...the first of the ...

...the first of the ...
...the first of the ...
...the first of the ...

...the first of the ...
...the first of the ...
...the first of the ...

...the first of the ...
...the first of the ...
...the first of the ...

...the first of the ...
...the first of the ...
...the first of the ...

...the first of the ...
...the first of the ...
...the first of the ...

SECTION 15221. PUMPING EQUIPMENT

1. APPLICABLE PUBLICATIONS: The following publications of the issues listed below, but referred to elsewhere by basic designation only, form a part of this specification to the extent indicated by the references thereto (where a number is suffixed to the specification number, it denotes the effective amendment of the specification):

1.1 Federal Specifications:

HH-I-523C	Insulation blocks and pipe covering, thermal (calcium silicate).
HH-P-46E	Packing; asbestos, sheet, compressed.
TT-E-489F	Enamel, alkyd, gloss.
TT-E-496B(1)	Enamel, heat-resisting (400 degrees F.), black.
TT-P-28E	Paint, aluminum, heat-resisting (1000 degrees F.).

1.2 American National Standards Institute (ANSI):

B16.3-71	Malleable-iron screwed fittings, 150 and 300 pounds.
B16.9-71	Wrought steel butt welding fittings.

1.3 American Society for Testing and Materials (ASTM):

A53-73	Welded and seamless steel pipe.
A120-73	Black and hot dipped zinc-coated (galvanized) welded and seamless steel pipe.

1.4 American Water Works Association (AWWA):

E101-71	Deep Well Vertical Turbine Pumps - Line Shaft and Submersible types.
---------	--

1.5 National Fire Protection Association (NFPA):

No. 70-1975	National Electrical Code.
-------------	---------------------------

2. SUBMITTALS REQUIRED: Shop drawings, manufacturer's data and certificates for equipment, materials, finish, and pertinent details for each system shall be submitted and approved before procurement, fabrication or delivery of such items to the job site. Partial submission will not be acceptable. Descriptive data shall be annotated to show the specific model, type and size of each item the Contractor proposes to furnish. The submittal requirements of Section 15011, General Requirements, Mechanical, applies to the following lists.

2.1 Manufacturer's Data:

- a. Pumps
- b. Motors and Controllers
- c. Diesel engine
- d. Battery and battery charger
- e. Exhaust piping and muffler

2.2 Shop Drawings: Pumps, motors, controllers, diesel engine and exhaust system. Drawings shall show complete layout of pumping system showing arrangement of pumps, motors, drives, diesel engine, controllers, starting system, and fuel and exhaust system.

2.3 Certificates: Submit notarized certificates from the manufacturer attesting that each of the following items conform to all requirements of this specification and of reference publications,

- a. Pumps
- b. Motors and Controllers
- c. Diesel Engine
- d. Battery charger
- e. Exhaust piping
- f. Paints and coatings

2.4 Pump characteristics curves: The Contractor shall furnish with each pump and drive prior to shipment, certified characteristics curves showing the capacity, head, efficiency, and brake horsepower throughout the entire range of the pump.

3. GENERAL REQUIREMENTS: Section 15011, General Requirements, Mechanical, applies to all work in this section. The work includes the provision of pumping assemblies for the four new wells, complete with all appurtenances. All pumps shall be electric motor driven; in addition, the pump at Well House No. 617 shall be provided with combination right angle drive for use with the auxiliary diesel engine which shall be provided at this well house. Each installation shall be provided complete, tested, and in operation.

4. PUMPS: All pumps shall be of the deep well, turbine type, water-lubricated, open line shaft pumps with surface discharge, and shall conform to AWWA E101 as modified herein. Each pump shall be provided with a non-reverse ratchet to prevent reverse rotation. Each pump shall have an efficiency of not less than 80 percent.

4.1 Pump Materials: Materials for all components of the pumps shall be as set forth in "Table 1" and "Section A4-Specifications" of AWWA E 101, as modified herein. Impellers shall be of bronze, and of the enclosed type. The steel pipe for the pump columns shall be of standard weight zinc-coated steel pipe conforming to ASTM A53 or A120. Strainer is required on the suction pipe. Motors and controllers are specified hereinafter in the paragraph titled "Electrical".

4.2 Pumping Conditions: Speed of pumps shall be coordinated with standard speed of electric motor used and shall be nominally 1750 RPM. Bids shall be based on pumps operating with a capacity of 250 gallons per minute against the heads indicated, and with motor horsepower and electrical characteristics indicated. Discharge heads indicated are those at the discharge flange of the pump. Total dynamic head on each pump shall also include the lift in the well, as determined by flow tests of the respective completed well. Pumps shall be provided with sufficient column and line shaft to prevent breaking suction. In case actual conditions differ from those specified or shown, or both, the contract price will be adjusted in accordance with the contract.

5. RIGHT ANGLE DRIVE: The pump at Well House No. 617 shall be provided with combination electric motor and right angle gear drive for dual drive arrangement. The drive shall have one to one gear ratio to transmit the power from the engine to the pump at normal operating speed and shall be of the vertical, hollow shaft, spiral bevel gear type equipped with anti-friction bearings and a base flange matching the pump head flange. It shall be conservatively rated to transmit the maximum power requirements of the pump and be equipped with a heavy duty ball thrust bearing capable of carrying the hydraulic thrust of the pump and the weight of the rotating element. An oil reservoir of ample capacity shall supply adequate lubrication to the gears and bearings. A suitable motor stand shall be furnished which provides ample room for a sliding clutch for alternating the prime mover. A sliding clutch shall be mounted on the head shaft so the gears do not operate when the pump is driven by the electric motor. A non reverse ratchet shall be incorporated in the clutch to prevent backspin in the event of reverse rotation.

6. AUXILIARY DIESEL ENGINE: An auxiliary diesel engine shall be provided for the pump at Well House No. 617 for operating the pump through the right angle drive. The diesel engine shall be a multi-cylinder, water cooled diesel power plant with maximum horsepower required to operate the pump continuously at the rated speed of the pump over the entire head capacity range of the pump. Engine shall be a 4-cylinder overhead valve type for operation on No. 2 diesel fuel. Bore and stroke shall be at least 3.90 inches by 3.60 inches, with at least 172 cubic inches displacement. RPM shall not exceed 1750. The engine shall be arranged for electric motor cranking and shall be equipped with a compression ignition system, battery and required appurtenances, and shall include an adjustable governor, fuel injection pump and injection system, control panel with oil pressure and water temperature gages, gravity fuel tank, air cleaner, oil filter, batter charging generator, radiator and associated cooling system components, exhaust pipe and muffler, clutch take-off assembly, and all other accessories necessary for proper and efficient engine operation. Gravity fuel tank shall be mounted on the unit, and shall have sufficient capacity for at least four hours operation at full pump operating capacity. Diesel engine shall have manual push button start and stop. Starting shall be manually by push button from a battery power source.

6.1 Engine Cranking Battery shall be sized by manufacturer to provide 10 successive cranking attempts of 30 seconds each with a two minute rest between each attempt, at a temperature of 32 degrees Fahrenheit, while retaining a battery voltage of 1.0 volt or more per cell. Specific gravity shall not exceed 1.250. Battery shall be complete with connectors, cable terminals, acid resistant racks and one filling of electrolyte.

6.2 Battery Charger, electric type, shall be mounted on wall of pump house and shall be the rectifier type for operation with 120 volt 60 hertz. Charger shall be protected by an automatic circuit breaker and shall have capacity to charge two 6 volt batteries or one 12 volt battery at eight to five amps. One direct current ammeter shall be included and shall be flush mounted on the front of the enclosure. All metal parts shall be corrosion resistant or shall be suitably protected against corrosion. Housing for charger shall be drip-proof construction. Battery charger shall have self regulation and shall operate automatically for both cranking and charging modes so that manual switch on-off is not required.

6.3 Engine exhaust muffler (silencer) shall have flanged connections and shall be furnished in accordance with the engine manufacturer's recommendations for residential class silencing. Muffler & all exhaust pipe shall be supported indepently of engine exhaust manifold.

6.4 Exhaust Piping shall be extra strong black steel pipe conforming to ASTM A53 or A120. Piping 2 inches and smaller shall have threaded fittings. Piping 2-1/2 inches and larger shall have welded fittings. Threaded fittings shall conform to ANSI B16.3, Class 300. Welding fittings shall conform to ANSI B16.9 of the same material and weight as the piping in which they are installed. Flanges shall be provided for final connections to diesel engine and exhaust muffler. Gaskets shall be 1/16 inch thick asbestos packing conforming to HH-P-46. Where pipe passes through the building wall it shall be run in an asbestos cement sleeve securely mounted in the wall.

6.4.1 Insulation: Exhaust piping shall be insulated inside the building with calcium silicate insulation conforming to HH-I-523, Type II, Class A, 2 inches thick. Insulation shall be protected by a 0.016 inch thick aluminum jacket with a factory applied moisture barrier and secured by aluminum straps or screws spaced 8 inches on centers.

6.5 Metal Instruction Plate shall be mounted on the engine unit giving the manufacturer's recommendations for lubricating oil and other pertinent information.

6.6 Safety guards: The interconnecting shafting between the diesel engine and the combination drive and all other rotating units shall be provided with approved safety guards for protection of operating personnel.

7. ELECTRICAL:

7.1 Motors and controllers shall be furnished with their respective pieces of equipment and shall conform to and shall have all electrical connections provided under section entitled "Interior Electrical Systems". The cost of providing additional electrical service and related work shall be included under this section when motors and equipment furnished are larger than sizes indicated.

7.2 Electrical work is specified in the section entitled "Interior Electrical Systems", except for control wiring. Control wiring shall be provided under this section and shall conform to NFPA 70. The conduit shall be rigid zinc coated steel.

8. PAINTING OF EQUIPMENT: Exterior surfaces of equipment shall be provided with, as a minimum, one coat of primer and two coats of paint; except that surfaces subject to temperatures above 120 degrees F. shall be provided with, as a minimum, two coats of heat resisting paint applied directly on bare, clean metal. It is desirable that all coats be shop applied; however, if the manufacturer's standard shop painting system does not meet these requirements, field applied coats shall be provided. Shop coats shall be lightly sanded before application of field applied coats. Field applied paint shall be applied to a dry film thickness of not less than one mil for each coat; paint shall conform to TT-E-489, except heat resisting paint shall conform to TT-E-496, Type II for surfaces temperatures between 120 and 400 degrees Fahrenheit, and to TT-P-28 for surfaces temperatures greater than 400 degrees F. Equipment painting, both shop and field, shall be provided under this section.

9. FIELD PAINTING:

9.1 Exhaust Piping: Before insulating exhaust piping, the piping shall be painted as specified herein. Before application of paint, the surfaces to be painted shall be cleaned to bare metal; paint shall be applied on the same day as cleaning of surfaces. Metal surfaces shall receive two coats of heat-resisting aluminum paint conforming to TT-P-28, applied to a total minimum dry film thickness of 2.0 mils. The first coat shall be allowed to thoroughly dry before application of the second coat.

9.2 Equipment: Factory finishes damaged during transit, handling, and installation shall be restored to original condition. Bolts and other anchorage devices shall be painted with paint systems equal to that specified for the equipment.

10. INSTALLATION: All equipment shall be provided with the equipment manufacturer's printed installation instructions, and the equipment shall be installed in strict accordance with these printed instructions. Pump motors and engine shall be set accurately, properly aligned, and securely mounted to supporting construction.

11. PERFORMANCE TESTS: Each pumping unit and diesel engine, after being put into operation, shall be tested to demonstrate conformance with the specified requirements. Pumps and diesel engine shall be operated at the design capacities for a period of at least two hours and shall be observed during this period. All defects shall be corrected. Tests shall be repeated as necessary until all defects are corrected. Equipment which fails to meet the specified requirements shall be removed and replaced with proper equipment, at no additional cost to the Government.

---o0o---

SECTION 15272

WATER DISTRIBUTION

1. APPLICABLE PUBLICATIONS: The following publications of the issues listed below, but referred to elsewhere by basic designation only, form a part of this specification to the extent indicated by references thereto (where a number is suffixed to the specification number, it denotes the effective amendment to the specification):

1.1 Federal Specifications:

GG-G-76C(1)	Gages, Pressure and Vacuum, dial indicating.
WW-P-421D	Pipe, cast gray and ductile iron, pressure (for water and other liquids).
WW-V-54D(1)	Valve, gate, bronze (125, 150, and 200-pound; threaded ends, flange ends, solder end, and brazed ends, for land use).
WW-V-58B	Valves, gate, cast-iron; threaded and flanged (for land use).

1.2 Military Specifications:

MIL-C-18480A(3)	Coating compound, bituminous solvent, coal tar base.
MIL-V-18436c(2)	Valves, check: bronze, cast-iron, and steel body.

1.3 American Society for Testing and Materials (ASTM):

B 88-76	Seamless copper water tube.
---------	-----------------------------

1.4 American Water Works Association (AWWA):

C 106-75	Cast-iron pipe centrifugally cast in metal molds, for water or other liquids.
C 108-75	Cast-iron pipe centrifugally cast in sand-lined molds, for water or other liquids.
C 110-71	Gray-iron and ductile-iron fittings, 2 in. through 48 in., for water and other liquids.
C 111-72	Rubber gasket joints for cast-iron and ductile-iron pressure pipe and fittings.
C 115-75	Flanged cast-iron and ductile-iron pipe with threaded flanges.
C 151-76	Ductile-iron pipe, centrifugally cast in metal molds or sand-lined molds, for water or other liquids.
C 500-71	Gate valves - 3 in. through 48 in. - for water and other liquids.
C 600-64	Installation of cast-iron water mains.
C 601-68	Disinfecting water mains.
C 702-71	Cold-water Meters

1.5 Underwriters' Laboratories (UL):

UL 194	The performance of gasketed joints for cast-iron pressure pipe and fittings, May 1973.
UL 262	Gate valves for fire-protection service, May 1973.
UL 312	Swing-check valves for fire-protection service, June 1975.

1.6 American National Standards Institute (ANSI):

A21.1-(1967)(R1972)	Thickness design of cast-iron pipe.
A21.6-1975	Cast-iron pipe centrifugally cast in metal molds for water or other liquids.
A21.8-1975	Cast-iron pipe centrifugally cast in sand-lined molds, for water or other liquids.
A21.10-1971	Gray-iron and ductile-iron fittings, 2 in. through 48 in., for water and other liquids.
A21.11-1972	Rubber gasket joints for cast-iron and ductile-iron pressure pipe and fittings.
A21.15-1975	Flanged cast-iron and ductile-iron pipe with threaded flanges.
A21.51-1976	Ductile-iron pipe, centrifugally cast in metal molds or sand-lined molds, for water or other liquids.
B16.18-1972	Cast bronze solder-joint pressure fittings.
B16.22-1973	Wrought copper and bronze solder-joint pressure fittings.

1.7 National Fire Protection Association (NFPA):

24-73 Outside Protection.

1.8 LANTDIV Plates:

WD-1 Standard thrust blocks for water mains.

2. GENERAL REQUIREMENTS: Section 15011, General Requirements, Mechanical, also applies to this section except as specified otherwise. The work includes provision of water piping and appurtenances both inside and outside of well houses.

3. SUBMITTALS REQUIRED: Shop drawings, manufacturer's data and certificates for equipment, materials, finish, and pertinent details for each system shall be submitted and approved before procurement, fabrication or delivery of such items to the job site. Partial submission will not be acceptable. Descriptive data shall be annotated to show the specific model, type and size of each item the Contractor proposes to furnish. The submittal requirements of Section 15011, General Requirements, Mechanical, applies to the following lists.

3.1 Manufacturer's Data:

- a. Valves.
- b. Valve boxes.
- c. Gages.

3.2 Certificates: Submit notarized certificates from the manufacturer attesting that each of the following items conform to all requirements of this specification and of reference publications.

- a. Pipe and pipe fittings and joints
- b. Valves
- c. Gages

4. DELIVERY, STORAGE, AND PROTECTION: Materials shall be delivered to the site in an undamaged condition. Materials shall be carefully stored to provide proper protection against damage. Defective or damaged materials shall be replaced by the Contractor at no expense to the Government. Handling requirements are specified hereinafter.

5. MATERIALS:

5.1 Pipe: Water piping 4 inches in diameter and larger shall be either cast gray or ductile iron. Piping within well houses shall be flanged. Air release lines on water piping shall be copper tubing.

5.1.1 Cast-iron pipe shall conform to the applicable requirements of WW-P-421 for Grade A, B, or C, as modified herein. Pipe wall thickness shall be based on a working pressure of 150 pounds per square inch and a depth of cover of 5 feet with laying condition B. Pipe shall have cement-mortar lining and shall have ends suitable for joints specified hereinafter. Factory-applied coatings on pipe shall be of a coal tar base material compatible with the coal tar base coating specified for field painting.

(a) Gray cast-iron pipe shall conform to the applicable requirements of ANSI A21.6 (AWWA C106) or ANSI A21.8 (AWWA C108), except as modified by WW-P-421, and except that flanged pipe shall conform to ANSI A21.15 (AWWA C115) minimum 150 PSI working pressure, outside coated, cement-mortar lined.

(b) Ductile-iron pipe shall conform to the applicable requirements of ANSI A21.51 (AWWA C151), except as modified by WW-P-421, and except that flanged pipe shall conform to ANSI A21.15, minimum 150 PSI working pressure, outside coated, cement-mortar lined.

5.1.2 Copper tubing shall be hard copper tubing conforming to ASTM B88, Type K.

5.2 Fittings:

5.2.1 Fittings for cast gray and ductile iron pipe shall conform to the applicable requirements of ANSI A21.10 (AWWA C110) and may be either cast gray or ductile iron; fittings with push-on joint ends shall be as specified for bell-and-spigot joint ends except that bell design shall be modified, as approved, for push-on joints. Fittings shall have pressure rating at least equivalent to that of the pipe. Fittings shall have cement mortar lining equivalent to that of the pipe lining. Within the well houses fittings shall be flanged. Fittings where gages and air release lines occur shall have tapped bases for connections thereof. Fittings for aboveground pipe shall be shop primed with a coal tar base coating material compatible with the coal tar base coating specified for field painting.

5.2.2 Fittings for copper tubing shall conform to the applicable requirements of ANSI B16.18 or B16.22 for solder-joint fittings.

5.3 Joints and Jointing Materials: All cast gray or ductile iron piping within the well houses shall have flanged joints.

5.3.1 Cast Gray and Ductile Iron Pipe:

(a) Push-on Joints: Shape of pipe ends shall conform to the applicable requirements of WW-P-421 for Type II pipe. Conformation of ends for fittings shall conform to the applicable requirements of ANSI A21.11 (AWWA C111). Gaskets and lubricants for pipe and fittings shall conform to the applicable requirements of ANSI A21.11 (AWWA C111). Drawings of the joint and gasket shall be furnished. Push-on joints shall also meet the applicable requirements of UL 194.

(b) Mechanical Joints: Dimensional and material requirements for pipe ends, glands, bolts and nuts, and gaskets shall conform to the applicable requirements of ANSI A21.11 (AWWA C111) or to the applicable requirements specified for Type III pipe in WW-P-421. Mechanical joints shall also meet the applicable requirements of UL 194.

(c) Flanged Joints: Ends of pipe and fittings shall be provided with cast-iron flanges conforming to the applicable requirements of ANSI A21.15. Bolts, nuts, and gaskets for flanged connections shall conform to the recommendations in the Appendix to ANSI A21.15. Gaskets shall be plain rubber, 1/8-inch thick.

(d) Adapters: Adapters shall be provided for connections of push-on joint or mechanical joint pipe to flanged pipe and accessories.

5.3.2 Insulating Joints: Joints between pipe of dissimilar metals shall be made up with a rubber-gasketed or other suitable approved type of insulating joint or dielectric coupling which will effectively prevent metal-to-metal contact between adjacent sections of piping.

5.4 Valves: Valves conforming to the same specification shall be of one make throughout the project.

5.4.1 Gate Valves:

(a) Gate Valves on Buried Piping: Valves shall have non-rising stems and shall be double-disc parallel seat type. Valves shall open by counterclockwise rotation of the valve stem. Valves shall have O-ring stem seals, except when gearing is specified, in which case conventional packing shall be used in lieu of O-ring seal. Stuffing boxes shall be bolted and constructed so as to permit the easy removal of parts for repairs.

(1) Valves 3-inch Size and Larger: Except as otherwise specified hereinafter, valves shall conform to AWWA C500 or to UL 262. Valves shall have mechanical-joint or push-on joint ends and gaskets conforming to ANSI A21.11 (AWWA C111). Valves conforming to UL 262 shall be designed for a hydraulic working pressure of 175 psi.

(b) Gate Valves in Above Ground Locations:

(1) Valves 3-inch Size and Larger: Valves shall conform to WW-V-58 or to UL 262. Valves shall be of the outside-screw-and-yoke configuration. Valves shall have flanged ends unless otherwise indicated or otherwise specified hereinafter. Valves conforming to WW-V-58 shall be Type II, Class 1. Valves conforming to UL 262 shall be designed for a hydraulic working pressure of 175 psi.

(2) Valves Smaller Than 3-inch Size: Valves shall conform to either WW-V-54, WW-V-58, or to UL 262. Valves conforming to WW-V-54 shall be Type III, Class A. Valves conforming to WW-V-58 shall be Type II, Class 1. Valves conforming to UL 262 shall be of outside-screw-and-yoke configuration and shall be designed for a hydraulic working pressure of 175 psi. Valves shall have threaded ends.

5.4.2 Check Valves:

(a) Check Valves 3-inch Size and Larger: Valves shall conform to MIL-V-18436 or to UL 312. Valves shall have flanged ends.

Swing-check valves shall have clear-port opening. Valves conforming to MIL-V-18436 shall be Type III, shall have cast-iron or steel bodies with bronze trim, and shall be designed for a hydraulic working pressure of 175 psi.

5.4.3 Automatic Air Release Valves: Automatic air release valves shall be designed to operate under pressure to allow entrapped air to escape from the pipeline. After air escapes from the valve, it shall close to prevent escape of water. Valve shall then remain closed until air again accumulates, and the opening cycle shall then be automatically repeated. Valves shall have 3/4-inch threaded inlet and shall have cast iron bodies and covers, stainless steel floats, bronze trim, and Buna-N seats. Valves shall be rated for 150 psig minimum working pressure. Venting capacity shall be a maximum of 22 cubic feet of free air per minute. Valves shall be cleaned and shop painted in accordance with manufacturers' standard practice.

5.5 Gages: Gages shall conform to GG-G-76, Class 1, Style A, Type 1, with 4½ inch dial, brass case, bronze tube, and scale calibrated in psig, except direct reading gage for static and drawdown shall be calibrated in feet of water. A direct reading gage shall be provided at each well.

5.6 Valve Boxes: Each gate valve on buried piping shall be provided with an adjustable cast-iron valve box of a size suitable for the valve on which it is to be used. Outside of paved areas boxes may be of plastic; such plastic valve boxes shall be constructed of ABS (Acrylonitrile-Butadiene-Styrene) plastic or of inorganic fiber reinforced black polyolefin plastic. The head shall be round and the lid shall have the word "WATER" cast on it. The least diameter of the shaft of the box shall be 5-1/4 inches. Each cast-iron box shall be given a heavy coat of bituminous paint.

5.7 Totalizer meters shall conform to AWWA C 702.

6. INSTALLATION OF PIPELINES:

6.1 Location of Water Lines: Water lines shall not be laid in the same trench with electrical wiring.

6.2 Handling: Pipe, fittings, valves, and other accessories shall be handled in such manner as to insure delivery to the trench in sound, undamaged condition. Special care shall be taken not to injure pipe coatings or linings. If coatings or linings of pipe and fittings are damaged, satisfactory repairs shall be made at no extra cost to the Government. Pipe shall be carried and not dragged. Rubber gaskets that are not to be installed immediately shall not be left in the sunlight, but shall be stored under cover out of direct sunlight.

6.3 Pipe Laying and Jointing: Pipe, fittings, valves and accessories will be carefully inspected before and after installation and those found defective will be rejected. Pipe and fittings shall be free from fins and burrs. Before being placed in position, pipe, fittings, valves, and accessories shall be cleaned, and shall be maintained in a clean condition. Proper facilities shall be provided for lowering sections of pipe into trenches. Under no circumstances shall pipe, fittings, valves, or any other water line material be dropped or dumped into trenches. Pipe shall be cut accurately to measurements established at the site and shall be worked into place without springing or forcing. Piping that does not allow sufficient space for proper installation of jointing material shall be replaced by one of proper dimensions. Blocking or wedging between bells and spigots will not be permitted. Bell-and-spigot pipe shall be laid with the bell end pointing in the direction of laying. The pipe shall be graded in straight lines, taking care to avoid the formation of any dips or low points. Pipe shall be supported at its proper elevation and grade, care being taken to secure firm and uniform support. Wood support blocking will not be permitted. The full length of each section of buried pipe and fittings shall rest solidly on the pipe bed, with recesses excavated to accommodate bells, joints, and couplings. Anchors and supports shall be provided where necessary and where indicated on the project drawings for fastening work into place. Proper provision shall be made for the expansion and contraction of pipe lines. Trenches shall be kept free of water until joints have been properly made. Open ends of pipe at the end of each day's work shall be closed temporarily with wood blocks or bulkheads. Pipe shall not be laid when the conditions of trench or weather are unsuitable. Depth of bury for buried pipe shall be not less than three feet. Piping shall be inspected, tested, and approved before being completely buried, covered, or concealed. Excavation bedding and backfilling of pipe trenches shall be as specified in the section entitled "Earthwork", as modified herein.

6.4 Manufacturer's Recommendations: Where installation procedures or any part thereof are required to be in accordance with the recommendations of the manufacturer of the material being installed, printed copies of these recommendations shall be furnished to the Contracting Officer prior to installation. Installation of the item will not be allowed to proceed until the recommendations are received. Failure to furnish these recommendations can be cause for rejection of the material.

6.5 Special Installation Requirements: Cast-iron pipe and copper tubing shall be installed in accordance with AWWA-C-600 except as modified herein.

6.6 Joints:

6.6.1 Joints for Cast-Iron Pipe: Push-on and mechanical joints shall be made in accordance with the requirements of AWWA C 600; mechanical joints shall further follow the "Notes on Installation of Mechanical Joints" given in ANSI A21.11 (AWWA C111). Flanged-joints shall be made up tight, care being taken to avoid undue strain on flanges, valves, fittings, pump nozzles, and other equipment and accessories.

6.6.2 Joints for Copper Tubing: Copper tubing shall be cut with square ends, and all burrs and fins removed. Tubing shall be handled carefully and all tubing dented, gouged, or otherwise damaged shall be replaced with undamaged tubing. Solder joints shall be made using 50-50 lead-tin solder. End of tubing and inside of fitting or coupling shall first be cleaned with wire brush or abrasive. A rosin flux shall then be applied to the tubing end and on the recess inside of fitting or coupling. Tubing end shall then be inserted to the full depth of the recess and soldered. For compression joints on flared tubing, the tubing shall be inserted through the coupling nut and flared with an approved flaring tool.

6.7 Connections to Existing Water Supply Systems: Tapping or drilling machine valve and sleeves shall be used for connections to existing water lines. The sleeves shall be bolted around the mains and calked; the valve bolted to the branch. The valve shall conform to the latest specification for valves of the American Water Works Association. The valve shall be opened, the drilling machine attached; the tap made, the valve closed and the drilling machine removed all without interruption of service. The Contractor shall furnish all material required to make connections into the existing water supply systems; and shall perform all necessary excavating, backfilling and other incidental labor as required. The Contractor shall furnish the labor and the tapping or drilling machine for making the actual connections to the existing systems. The Contracting Officer shall be notified in writing at least ten days prior to the date the connections are required. Approval by the Contracting Officer shall be received before any service is interrupted.

6.8 Pipe Anchorage: Anchorage of buried pipe lines shall be by means of concrete thrust blocks (reaction backing), using concrete with a minimum compressive strength of 2000 psi. All 1/16 and sharper bends, tees, and dead ends of pipe shall be securely blocked in the direction of flow with poured-in-place concrete bearing solidly against the pipe and affording a minimum of 3 square feet of bearing area against a vertical trench face for 3- and 4-inch pipe, and in accordance with LANTDIV Plate WD-1 for piping 6-inch diameter and larger. Plate WD-1 appears at the end of this section.

6.9 Setting Valves and Valve Boxes: Valves and valve boxes shall be set plumb, and centered, with valve boxes placed directly over the valves. Valve boxes shall, if possible, be located outside the area of the roads and streets. Earth fill shall be carefully tamped around the valve box to a distance of 4 feet on all sides of the box, or to the undisturbed trench face if less than 4 feet. Valves shall have the interiors cleaned of all foreign matter before installation. Stuffing boxes shall be tightened and the valve shall be inspected in opened and closed positions to see that all parts are in working condition.

7. DISINFECTION: New water piping and existing water piping affected by Contractor's operations shall be disinfected in accordance with AWWA C601. Piping system shall be filled with solution containing minimum of 50 parts per million of available chlorine and allowed to stand for minimum period of 24 hours. Solution shall be flushed from system with clean water until maximum residual chlorine content is not greater than 0.2 parts per million.

8. IDENTIFICATION TAGS AND PLATES: Valves shall be provided with tags or plates numbered and stamped for their usage. Plates and tags shall be of brass or suitable nonferrous material and shall be securely mounted or attached.

9. FIELD TESTING AND INSPECTION:

9.1 General: All work shall be proved to be in first class condition and constructed properly in accordance with the drawings and specifications. All defects and leaks disclosed by the tests shall be corrected. Piping shall not be completely buried, covered, or concealed until it has been inspected, tested, and approved, except when procedure is modified by the referenced installation and testing standard.

9.2 Field Tests: Testing procedures shall be as specified hereinafter for the respective kind of piping. Hydrostatic pressure for pressure test shall be 50 percent in excess of the maximum working pressure of the system, but shall be not less than 100 psi and shall be held for a minimum of one hour. Prior to the pressure test, that portion of the water line being treated shall be filled with water for a soaking period of not less than 24 hours. Hydrostatic pressure for leakage test for all systems shall be the maximum working pressure of the system, except as otherwise specified hereinafter. Leakage test may be performed at the same time and at the same test pressure as the pressure test. Pipe, joints, valves and fittings in the test section shall be examined. Equipment shall be tested in operation to demonstrate compliance with specification requirements. Each control valve shall be fully opened and closed under water pressure. Appliances, water and equipment for testing shall be furnished by the Contractor at his own expense, and the systems tested until proved satisfactory. The Contractor shall submit a certificate similar to that specified in NFPA 24 with a request for a formal inspection at least two working days prior to the date the inspection is to take place. At this inspection, any or all of the required tests shall be repeated as required.

9.2.1 Testing of cast-iron pipelines and copper tubing lines shall be in accordance with AWWA C 600, except as specified otherwise herein. The amount of leakage on lines with push-on or mechanical joints shall not exceed the amounts given in AWWA C 600. No leakage will be allowed at flanged or soldered joints.

10. FIELD PAINTING: After installation, all exposed surfaces of aboveground cast gray and ductile iron pipe and fittings and valves shall be field painted. Damages to shop applied coatings shall be touched up before application of field paint. Paint shall be applied to clean, dry surfaces only. Where more than one coat of paint is specified the first coat shall be allowed to dry thoroughly before application of the second coat. Cast gray and ductile iron pipe and fittings shall receive a coal tar base coating conforming to MIL-C-18480, applied to a minimum dry film thickness of 30 mils. Cast gray and ductile iron valves shall receive two coats of paint of the same type as factory applied paint; each coat shall be applied to a dry film thickness of not less than 1.0 mil.

---oOo---

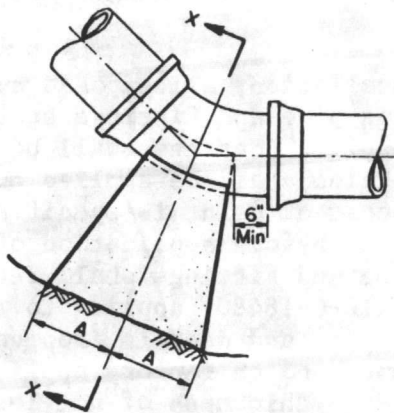

PLAN
BENDS

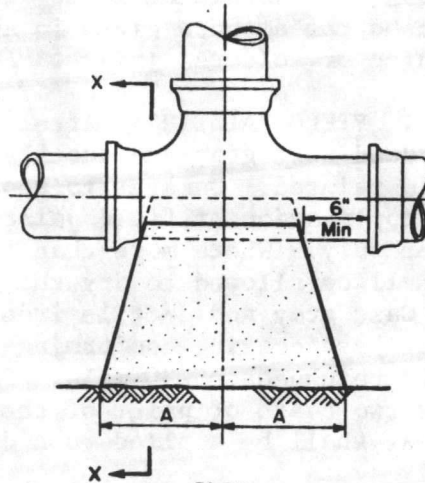

PLAN
TEES

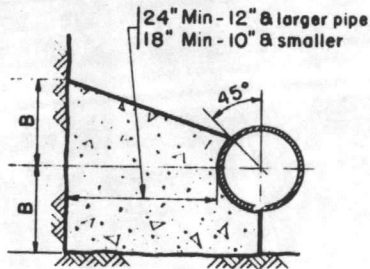

SECTION X-X
BENDS & TEES

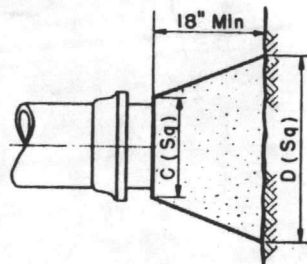

PLAN & ELEVATION
PLUGS

SIZE	1/4 BENDS		1/8 BENDS		1/16 BENDS		TEES		PLUGS	
	A	B	A	B	A	B	A	B	C	D
6"	16"	10"	9"	10"	6"	8"	10"	12"	10"	21"
8"	22"	13"	12"	13"	8"	10"	13"	16"	12"	29"
10"	26"	17"	14"	17"	10"	13"	16"	20"	14"	36"
12"	29"	21"	16"	21"	11"	16"	18"	24"	16"	41"
14"	35"	24"	19"	24"	12"	20"	22"	27"	18"	48"
16"	38"	27"	21"	27"	12"	24"	24"	30"	20"	54"

NOTE: Based on 100 p.s.i. static pressure plus A.W.W.A. water hammer
All bearing surfaces to be carried to undisturbed ground

**STANDARD THRUST BLOCKS
FOR WATER MAINS**

LANTDIV PLATE WD-1

SECTION 15840. DUCTWORK

1. APPLICABLE PUBLICATIONS; The following publications of the issues listed below, but referred to elsewhere by basic designation only, form a part of this specification to the extent indicated by the references there- to (where a number is suffixed to the specification number, it denotes the effective amendment to the specification):

Federal Specifications.

RR-W-365(1) Wire fabric (insect screening).

American Society for Testing and Materials (ASTM).

A525-73 Steel sheet, zinc-coated (galvanized) by the hot dip process.

Sheet Metal and Air-Conditioning Contractors' Nat'l. Association (SMACNA).

Section 1-1969 Low velocity duct construction.

2. DUCTWORK shall be sheet metal.

2.1 Sheet Metal Ductwork shall be provided in a neat workmanlike manner, and shall be constructed of zinc-coated sheet steel conforming to ASTM A525, coating designation G-50, except as specified otherwise. Ducts and accessories shall be constructed, braced, reinforced and installed in accordance with SMACNA low velocity duct manual. All rectangular ducts shall be cross-braced. Duct supports shall be not less than 1/8-inch by 1-inch zinc-coated flat bar. Unless otherwise indicated, all elbows shall have a center line radius not less than 1-1/2 times the width of the duct. All ducts shall be true to the dimensions indicated, and shall be straight and smooth on the inside with neatly finished air-tight joints.

2.2 Hardware cloth shall conform to RR-W-365, 4 x 4 mesh, galvanized after wearing.

3. CLEANING: All equipment, ductwork, etc. shall be cleaned thoroughly and in accordance with the best practice.

4. Verification of dimensions: The Contractor shall be responsible for the coordination and proper relation of his work to the building structure and to the work of all trades. The Contractor shall visit the premises and thoroughly familiarize himself with all dimensions in the field, and to advise the Contracting Officer of any discrepancy before performing any work.

END OF SECTION 15840

...the ... of the ...
...the ... of the ...
...the ... of the ...

...the ... of the ...
...the ... of the ...
...the ... of the ...

...the ... of the ...
...the ... of the ...
...the ... of the ...

...the ... of the ...
...the ... of the ...
...the ... of the ...

...the ... of the ...
...the ... of the ...
...the ... of the ...

...the ... of the ...
...the ... of the ...
...the ... of the ...

...the ... of the ...
...the ... of the ...
...the ... of the ...

...the ... of the ...
...the ... of the ...
...the ... of the ...

...the ... of the ...
...the ... of the ...
...the ... of the ...

...the ... of the ...
...the ... of the ...
...the ... of the ...

...the ... of the ...
...the ... of the ...
...the ... of the ...

...the ... of the ...
...the ... of the ...
...the ... of the ...

SECTION 16300. ELECTRICAL DISTRIBUTION, EXTERIOR

1. APPLICABLE PUBLICATIONS: The following specifications and standards of the issues listed below (including the amendments, addenda, revisions, and errata designated), but referred to hereinafter by basic designation only, form a part of this specification to the extent required by the references thereto:

1.1 Federal Specifications:

QQ-W-343D	Wire, Electrical (Uninsulated).
TT-C-490B	Cleaning Methods and Pretreatment of Ferrous Surfaces for Organic Coatings.
TT-E-489F (Int. Am 1)	Enamel; Alkyd, Gloss (For Exterior and Interior Surfaces).
TT-E-496B(2)	Enamel, Heat Resisting (400°F); Black.
TT-P-645	Primer, Paint, Zinc Chromate, Alkyd Type.
TT-W-5711	Wood Preservation: Treating Practices.
W-T-631	Transformers.

1.2 Military Specifications:

MIL-B-7883B	Brazing of Steels, Copper, Copper Alloys, and Nickel Alloys.
MIL-C-18480A(3)	Coating Compound, Bituminous Solvent, Coal Tar Base.
MIL-I-15126F(2)	Insulation Tape, Electrical, Pressure Sensitive Adhesive and Pressure Sensitive Thermosetting Adhesive.
MIL-H-55053B SUP 1A	Hardware, Pole Line, With Supplement.
MIL-P-15328C(1)	Primer, Pretreatment (Formula No. 117 for Metals).

1.3 U.S. Department of Agriculture, Rural Electrification Administration Standards (REA):

DT-5B (Electric)	Wood Crossarms (Solid and Laminated), Transmission Timbers, and Pole Keys, Jan. 72 (Rev. Mar 25, 1976).
PE-39	Filled Telephone Cable, 1976.

1.4 LANTDIV Pole Plates (Dated 3-75) Title

16-3	X-AB & X-AB-GAIN
16-11	F3
16-14	FDDE3-BUCK
16-15	TTT
16-18	Guy
16-20	Grounding
16-21	Conduit Riser

1.5 National Electrical Manufacturers Association Standards (NEMA):

LA 1-1976	Lightning Arrester.
SG 2-1975	High Voltage Fuses.

1.6 National Fire Protection Association (NFPA):

70-1975 National Electrical Code.

1.7 Underwriters' Laboratories, Inc. Standards (UL):

1 Flexible Steel Conduit, 1971 (R. SEP 72)
467 Grounding and Bonding Equipment, 1967 (R. OCT 72)
510 Insulating Tape, 1971.
514 Outlet Boxes and Fittings, 1969 (R. APR 72)

1.8 American National Standards Institute Standards (ANSI):

C2-1973 National Electrical Safety Code.
C29.1 to C29.7 Wet Process Porcelain Insulators.
incl. - 1961
C80.1-1966 Rigid Steel Conduit, Zinc Coated.
(R. 1971)

05.1-1972 Specifications and Dimensions for Wood Poles.
Z35.1-1972 Specification for Accident Prevention Signs.
C57.23.20-1974 Overhead-Type Distribution Transformers 67000 Volts and
Below; 500KVA and Smaller.

1.9 American Wood Preservers' Association (AWPA):

Book of Standards (Current Edition).

2. QUALITY CONTROL: All field tests to determine conformance with the specified requirements shall be performed in the presence of the Contracting Officer.

3. SUBMITTALS:

3.1 Shop drawings (SD) and catalog data (CD) for the following items shall be submitted to and approved by the Contracting Officer prior to the delivery of these items to the project site. The drawings and data shall show materials, finish and all pertinent details.

3.1.1 For Contracting Officer Approval:

Lightning Arresters (CD)
Relays (CD)
Guys and Anchors (CD)
Cutouts (CD)

Fuses (CD)
Transformers (SD, CD)
Control Schematic (SD)
Control Cable (CD)

3.2 Manufacturer's Certifications shall be submitted to the Contracting Officer for the following items prior to the delivery of these items to the project site. Certifications shall indicate complete compliance with specification requirements.

Conduit, Metal, Flexible

Wood Pole, Cross Arms
and Hardware

Tapes

Conduit Fittings

Insulator

Ground Rods

Wires and Cable, 600 Volt
and Less

Overhead Conductor

3.3 Materials Tests and Test Reports: The testing requirements for materials incorporated in referenced documents will be waived provided the manufacturer submits notarized certificates stating that previously manufactured materials have been tested by recognized laboratories, that such materials meet testing requirements specified, and that the materials furnished for this project are of the same type, quality, manufacture and make as that tested. Copies of the test reports need not be submitted except as specifically requested by the Contracting Officer.

3.4 Sample Certificate: The notarized certificate shall not contain statements that could be interpreted to imply that the proposed material does not meet all requirements for the specified material, i.e.; "as good as"; "achieve the same end use and results as materials formulated in compliance with the specified material"; "exceed or equal service and performance for specified material". The certificate should be simple and should state only that the proposed material meets the requirements for the specified material.

SAMPLE CERTIFICATE

The manufacturer hereby certifies that previously manufactured materials have been tested by recognized laboratories, that the tested material is of the same type, quality, manufacture and formulation as that furnished for this project, and that the tested material meets all the requirements of the following specifications:

SPECIFIED MATERIAL

C-150-74

TESTED MATERIAL

John Doe Company
Portland Cement

SIGNATURE AND TITLE

NOTARY SEAL

4. PRODUCT REQUIREMENTS:

4.1 Products: Unless otherwise indicated, the materials and equipment to be provided under this specification shall be products of manufacturers regularly engaged in the production of such equipment and shall be the manufacturer's latest design. The products shall conform to the applicable standards of UL and NEMA, unless specified otherwise. All items of the same type or ratings shall be identical. This shall be further understood to include products with accessories indicated.

4.2 Product Handling: Material arriving on job site shall be stored in such a manner as to keep material free of rust and dirt and so as to keep material properly aligned and true to shape. Rusty, dirty or misaligned material shall be rejected. Electrical conduit shall be stored to provide protection from the weather and accidental damage. Plastic conduit shall be stored on even supports and in locations not subject to direct sun rays or excessive heat. Cables shall be sealed, stored and handled carefully to avoid damage to the outer covering or insulation and damage from moisture and weather. Adequate protection shall be required at all times for electrical equipment and accessories until installed and accepted.

5. GENERAL REQUIREMENTS:

5.1 Description of Service: The building service shall be underground.

5.1.1 Underground Service: Underground service into buildings shall terminate at a point five feet outside the building and projections thereof. Connections of the underground service to the service switch, panelboard or load center is included in Section : INTERIOR ELECTRICAL SYSTEMS. Ends of the Underground conduit shall be protected by threaded metal caps until connections are made.

5.1.2 Electrical Characteristics: Electrical characteristics for this project shall be 12,470 volts primary, three phase 3 wire 60hertz and 208/120 volts secondary, three phase.

5.1.3 Unusual Service Conditions: All items furnished under this section shall be specifically suitable for the following unusual service conditions:

(1) Ambient Temperature: 100⁰F.

(2) Other Service Conditions: Humid, salt-laden air.

5.2 Service Interruptions: Where interruption of existing service is necessary, the Contracting Officer shall be notified in writing at least 10 days in advance. The interruption shall not be made unless authorized. The outage shall be as short a duration as possible and will take place at a time that will least interfere with normal station activities. The Government shall not be responsible for premium time to perform the work scheduled during the outage.

5.3 Nameplates: Major components of equipment shall have manufacturer's name, address, catalog number, model, style, or type on a plate securely and conspicuously attached to each item of equipment. Nameplates for electrical apparatus shall conform to NEMA standards.

5.4 Defective Equipment: Defective equipment or equipment damaged in the course of installation or test shall be replaced or repaired in a manner meeting with the approval of the Contracting Officer.

5.5 Prevention of Corrosion: Metallic materials shall be protected against corrosion. Outdoor equipment shall be given a rust inhibiting treatment and standard finish by the manufacturer. Aluminum shall not be used in contact with the earth, and where connected to dissimilar metal, shall be protected by approved fittings and treatment. Steel conduits installed underground shall be coated with an approved asphaltic paint, plastic coating, or shall be wrapped with a single layer of a pressure sensitive plastic tape, half lapped.

5.6 Warning Signs: Warning signs for electrical equipment and enclosures shall be provided for the fence, railing, or room enclosing electrical equipment such as substations, transformers, and switchgear having a nominal rating of 500 volts and above; and for the enclosure of metal-enclosed equipment, not so guarded or segregated. Signs shall conform to ANSI Standard Z35.1, shall be of metal, and shall have the legend "DANGER HIGH VOLTAGE" in two lines of letters of nominal 3 inch height. The signs shall be of such number and position as to be readable from all accessible sides, and shall be not more than 30 feet apart.

6. MATERIALS, EQUIPMENT, AND ASSEMBLIES:

6.1 Electrical Tapes: Tapes used for electrical insulation and other purposes in wire and cable splices, terminations, repairs and miscellaneous purposes shall be UL listed and UL approved for the specific application.

6.2 Calking Compound: Compound for the sealing of conduits, ducts, pipes, and sleeves shall be of a putty like consistency workable with the hands at temperatures as low as 35 degrees F, shall not slump at a temperature of 300 degrees F, and shall not harden materially when exposed to air. The compound shall readily calk or adhere to clean surfaces of the materials with which it is designed to be used. The compound shall have no injurious effects upon the hands of workmen or upon the materials.

6.3 Metal Conduit, Fittings and Accessories:

6.3.1 Rigid Metal Conduit: Unless indicated or specified otherwise, rigid metal conduit shall be of zinc coated rigid steel. Rigid steel conduit shall conform to ANSI C80.1.

Except where indicated or specified otherwise, rigid metal conduit installed underground shall be encased in concrete as specified for underground duct lines. Bushings shall be provided on each end of conduit sleeves which pass through cable vault walls and roofs.

6.3.2 Flexible Metal Conduit: Flexible conduit shall conform to UL-1. and shall be waterproof.

6.3.3 Fittings, Boxes, Covers and Outlets: Fittings and accessories for rigid metallic conduit and flexible steel conduit shall conform to UL 467 and UL 514, as applicable and shall meet the following requirements: Fittings, boxes, covers and outlets for use in outdoor work and in exposed indoor work, shall be cast or malleable iron or cast aluminum, and shall have threaded hubs. Iron or steel fittings, except bar hangers, shall be cadmium or zinc coated. Junction boxes shall conform to UL 514. Each box shall have the volume required by the National Electrical Code for the number of conductors enclosed in the box and shall meet the requirements of the National Electrical Code for installation of boxes and fittings. Cast metal conduit outlets and entrance caps shall conform to UL 514 and shall be cadmium or zinc coated if of ferrous metal. All fittings shall be waterproof unless otherwise noted.

6.3.4 Exposed Conduits: All exposed conduits, including pole risers and elbows for stub ups shall be hot dipped galvanized rigid steel conduit.

6.4 Wires and Cables: Conductor sizes are expressed in American Wire Gage (AWG) or in circular mils. Unless otherwise noted, conductor and conduit sizes indicated are for copper conductors. Overhead power transmission and primary distribution line conductors shall be as hereinafter specified. All conductors shall be copper. All grounding conductors shall be copper.

6.4.1 Connectors and Terminals: Connectors and terminals shall be designed and approved for use with the associated conductor material, and shall provide a uniform compression over the entire contact surface. Solderless terminal lugs shall be used on all stranded conductors. For connecting aluminum to copper, connectors shall be the circumferentially compressed, metallurgically bonded type.

6.4.2 Overhead Power Transmission and Primary Distribution Line Conductors. Conductors shall be of the type indicated or specified. Unless specified otherwise, the line conductors shall be bare and comply with the following specifications:

(a) Copper conductors, hard drawn and medium hard drawn, shall conform to Specification QQ-W-343.

6.4.3 Underground cabling and equipment shall conform to the respective specifications and other requirements specified herein:

(1) Grounding conductors shall be No. 6 AWG copper for grounding, conduit, and equipment and No. 4 AWG copper for grounding lightning arresters to ground rods for ground systems as shown.

(2) Neutral conductors shall have type TW insulation.

(3) All circuits 600 volts and less, including service entrances, shall be served by type USE cable, rated 600 volts, unless otherwise indicated or specified. Conductors shall be copper or aluminum or copper clad aluminum of equivalent ampacity. Conductor size and number of conductors in each cable shall be as indicated. Cable shall

be color coded. Conductor identification shall be provided within each enclosure where a tap, splice or termination is made. Conductor identification shall be by color coded insulated conductors, plastic coated self sticking printed markers, colored nylon cable ties and plates or heat shrink type sleeves. Control circuit terminations shall be properly identified.

Colors to be used in coding shall be:

208 VOLT SYSTEM

Neutral - White
Phase A - Black
Phase B - Red
Phase C - Blue
Grounding Conductor - Green

6.4.4 Bare copper wire for grounding, bonding and other uses, when not specified otherwise, shall conform to specification QQ-W-343.

6.4.5 Control Cable: Cable shall conform to REA PE-39, except as specified otherwise, and shall consist of one set of 6 pairs or two sets of 6 pairs separated by a metallic shield (12 pair), as indicated.

(a) Cable Construction:

(1) Conductors: The individual conductors shall be No. 19 stranded copper, insulated with polyethylene or polypropylene to a minimum thickness of 0.015 inch. Each pair shall be twisted one turn every 6 inches for an average 6 inches per twist in any 10 foot length of cable. Defective pair shall not be allowed.

(2) Inner Jacket: The 6 pair core shall be covered by a polyethylene or polypropylene jacket with a minimum thickness of 0.040 inch.

(3) Shield: A shield applied longitudinally with overlap shall be provided over the inner jacket consisting of either 0.010 ± 0.0008 inch fully annealed solid copper or 0.006 ± 0.005 inch copper-clad stainless steel.

(4) Outer Jacket: The outer jacket shall be either PVC, polyethylene or polypropylene with a minimum thickness of 90 mils.

(b) Cable Properties:

(1) Dielectric Strength:

Conductor to conductor - 6000 volts DC minimum for 3 seconds.
Conductor to ground - 20000 volts DC minimum for 3 seconds.

(2) Mutual Capacitance - average value not greater than 0.02 micro-farads per 1000 feet.

(3) Weight of Cable - approximate value: not greater than 300 pounds per 1000 feet.

(4) Crosstalk attenuation - between the two sets of 6 pair in the 12 pair cable: 35 decibels minimum.

(5) Waterproofing. Cable shall be filled with an approved insulating and waterproofing jelly or foam which shall not liquify or separate below 200 degrees F (93 degrees C).

(c) Tests and Certification: Cable shall be tested and an electrical test report shall be submitted to the Contracting Officer. The tests and report format shall be in accordance with REA PE-39. Manufacturer's certification shall be submitted to the Contracting Officer certifying that the cables are capable of being submerged in ground or in water, in the temperature range of 32 to 170 degrees F (0 to 77 degrees C), for a period of 5 years with less than 10 percent change in insulation resistivity and dielectric hysteresis.

6.4.6 Wires and cables for locations and uses not specified above shall be suitable for the purpose and in accordance with the National Electrical Code.

6.5 Wood Poles, Cross Arms and Hardware:

6.5.1 Poles shall be Southern Yellow Pine or Douglas Fir, length and class as indicated, conforming to ANSI 05.1, machine trimmed to a smooth surface, and free of crooks or sweeps exceeding 1 inch per 10 feet of pole length. Pole shall be bored, gamed and roofed before treatment. Plastic pole caps shall be added after treatment. Plastic caps shall have sealing rings raised to a height of 1/4 inch. They shall be filled to the top of the sealing ring with elastigum. Four tabs shall extend below the main body of the cap for nailing to the pole. One 1-1/4 inch aluminum nail shall be driven through each tab. No nails or holes shall be permitted on top of pole. Poles shall be pressure treated with Chromated Copper Arsenate (CCA) or Ammoniacal Copper Arsenite (ACA) in accordance with TT-W-571 and the American Wood Preserver's Association Book of Standards, Standard C4.

6.5.2 Wood Crossarms: Wood crossarms shall be solid type and shall conform to REA No. DT-5B (electric). Crossarms shall be pressure treated with Chromated Copper Arsenate (CCA) or Ammonical Copper Arsenite (ACA) and the minimum retention shall be 0.6 pounds per cubic foot of wood. Treatment shall be in accordance with AWPA Book of Standards, Standard C25. Crossarm braces shall be EEI standard, galvanized steel of the type, size and span as indicated.

6.5.3 Hardware shall be of standard type manufactured for pole line construction. Miscellaneous steel hardware, including bolts, washers, locknuts, eyenuts, guy attachments, guy clamps, etc. shall conform to MIL-H-55053, shall be hot dip galvanized, and shall be capable

of withstanding the maximum loading imposed thereon with the appropriate safety factors as specified by the National Electrical Safety Code for grade "B" construction in the medium Loading District.

6.5.4 Metal pins shall be zinc coated forged steel with lead thread height to suit the insulator provided, but not less than 4-1/2 inches high by 5/8 inch diameter. Shoulder shall be not less than 2 inch diameter, designed to distribute load uniformly to the crossarm. Shank shall be not less than 5/8 inch diameter by 5-3/4 inch length, equipped with 2 inch square washer, nut, and locknut, and shall project not less than 1/8 inch nor more than 2 inches beyond locknut. Zinc coated, broad base corner pins shall be used where indicated.

6.5.5 Insulators: Insulators for line wires having a potential of 600 volts or less shall be of porcelain or glass; those for wires having a higher potential shall be of porcelain. Porcelain line insulators shall conform to ANSI Standards C29.2 to C29.7 inclusive, and shall be the type that will not cause interference to radio receiving equipment. Mechanical strength of suspension insulators shall exceed the ultimate strength of the conductor attached thereto. Insulators for various uses shall have ratings not lower than the classes indicated in the following table:

Minimum rating of insulators in terms of class

<u>Service</u>	<u>Pin</u>	<u>Line post</u>	<u>Suspension</u>
5,000V. and below	55-3	-	52-2
5,001-15,000	55-5	57-1L or 1S	2 x 52-2

Insulators for use on secondary distribution system shall conform to ANSI C29.3. For conductors No. 4/0 and larger, insulators shall not be smaller than class 53-4. For conductors smaller than No. 4/0, insulators shall not be smaller than class 53-2. For 12.47kv construction, the guy strain insulators shall be Class 54-4, conforming to ANSI C29.4, except that where indicated, guy strain insulators shall be fiberglass type with electrical and mechanical characteristics equal to NEMA Class 54-4 insulators.

6.5.6 Storage and Handling of Poles: Poles held in storage for more than 2 weeks shall be stored in accordance with ANSI 05.1. The handling of poles shall be in accordance with ANSI 05.1, except that pointed tools capable of producing indentations more than 1 inch in depth shall not be used.

6.6 Ground Rods:

6.6.1 Copper Clad Steel Ground Rods: Rods shall be rolled to a commercially round shape from a welded copper clad steel manufactured by the molten-welding process or by the electro-formed process (molecularly

bonded). They shall have an ultimate tensile strength of 75,000 pounds per square inch (psi) and an elastic limit of 49,000 psi. The rods shall be not less than 3/4 inch in diameter by 10 feet in length and shall have a hard, clean, smooth, continuous copper surface and the proportion of copper shall be uniform throughout the length of the rod. The copper shall have a minimum wall thickness of 0.013 inch at any point on the rod. Each ground rod shall be die-stamped near the top with the name or trademark of the manufacturer and the length of the rod in feet.

6.7 Lightning Arresters: Distribution valve type 15kv arresters shall conform to NEMA LA-1, shall be designed for outdoor service, and shall be equipped with suitable mounting brackets for the applicable method of mounting.

6.8 Primary fuse cutouts shall be heavy duty, open type, rated 15kv. Open link rural type cutouts are not acceptable. Fuse ratings shall be equal to approximately 150 percent of the transformer full load rating, or shall be as indicated on the drawings and coordinated to the transformers provided. Cutouts and fuse links shall conform to NEMA No. SG-2.

6.9 Guys and Anchors:

6.9.1 Guy strand shall be high strength 1/2 inch in diameter, 7 strand, electrolytic or hot-dip galvanized steel with a minimum breaking strength of 7400 pounds.

6.9.2 Anchors and anchor rods shall be hot-dip galvanized. Anchor rods shall be designed for attachment to the anchors with which they are to be used.

(1) Swamp type anchors shall be used where required by the Contracting Officer and shall be of equivalent rating to other specified anchors.

(2) Screw type anchors shall be 10 inches in diameter with a minimum rating by the manufacturer of not less than 7000 pounds in "loose-dry" soil. The rods for screw anchors shall be at least 8 feet long and 3/4 inch in diameter, with a thimble-eye for attachment of the guy cable.

6.10 Transformers, power and distribution: shall conform to ANSI C57.12.20, and Federal Specification W-T-631, modified to permit a temperature rise of 65 degrees C.

6.10.1 Pole mounted distribution transformers shall be of the type I, mineral-oil insulated, two-winding type, and in accordance with the requirements hereinafter stated. Transformers shall be suitable in every respect for outdoor installation and rated as indicated. Power and distribution transformers shall be products of a manufacturer who has produced units of the same type, rating, and voltage as required for this project, within the 2-year period preceding the date of the invitation for bids, which have operated satisfactorily for at least one year prior to date of the invitation for bids. Evidence showing such production and satisfactory performance and provided reliability of the product shall be promptly submitted to the Contracting Officer upon request therefor. Transformers shall have four 2-1/2 percent rated KVA high-voltage taps above and below rated primary voltage. Transformers shall have cover-type high-voltage bushings. Transformer tank shall have a standard gray finish. Transformer installations shall include one primary fuse cutout and one lightning arrester for each underground phase conductor. All accessories for each installation shall conform to the applicable NEMA standards and shall be suitable in every respect for the intended service. Each transformer shall have its KVA rating conspicuously displayed on its tank.

6.10.2 Transformer mounting installations: Transformers shall be mounted as indicated.

6.11 Painting of Equipment: Exterior surfaces of equipment shall be provided with, as a minimum, one coat of primer and two coats of paint; except that surfaces subject to temperatures above 120 degrees F. shall be provided with, as a minimum, two coats of heat resisting enamel applied directly on bare, clean metal. It is desirable that all coats be shop applied; however, if the manufacturer's standard shop painting system does not meet these requirements, field applied coats shall be provided. Shop coats shall be lightly sanded before application of field applied coats. Field applied paint shall be applied to a dry film thickness of not less than 1 mil for each coat; paint shall conform to TT-E-489, except heat resisting enamel shall conform to TT-E-496, Type II for surface temperatures greater than 120 degrees F. Equipment painting, both shop and field, shall be provided under this section.

6.12 Control System: Controllers and relays shall be as indicated. Control system for wellhouse BA-109 shall operate as indicated and shall include the items indicated and required to make a workable system.

7. INSTALLATION:

7.1 General Requirements: Electrical installations shall conform to the National Electrical Safety Code, the National Electrical Code, and to the requirements specified herein.

7.2 Installation of Underground Systems:

05-76-6799

16300 - 11

7.2.1 Underground Conduit for Service Feeders: Underground conduit for service feeders into buildings shall be rigid steel. The ends of the conduit shall be protected by threaded metal caps; the threads shall be coated with graphite grease or other suitable coating. The underground portion of the conduit shall be encased in a concrete envelope having a wall thickness of not less than three inches and shall be buried as specified for underground ducts encased in concrete. Conduit ends and turnups shall be sealed, to prevent moisture from entering, with calking compound as hereinbefore specified.

7.2.2 Underground Conduit Without Concrete Encasement: Where indicated, conduits shall be installed underground without concrete encasement. Conduits shall be rigid steel and shall be field coated with a coal tar base conforming to MIL-C-18480, 30 mils thick; or shall have a factory applied PVC coating.

7.2.2.1 The top of conduits shall be not less than 24 inches below grade, and the conduit shall have a minimum slope of 3 inches in each 100 feet away from buildings and toward manholes and other necessary drainage points, and shall run in straight lines except where a change of direction is necessary. Joints in conduit runs shall be staggered not less than 6 inches in rows and tiers. As each conduit run is completed, a testing mandrel not less than 12 inches long with a diameter 1/4 inch less than the inside diameter of the conduit shall be drawn through, after which a brush with stiff bristles shall be drawn through until the conduit is clear of all particles of earth, sand or gravel; conduit plugs shall then be immediately installed. There shall be not less than 3 inches clearance from the conduit to each side of the trench. The bottom of trenches shall be graded carefully and shall be smooth; where rock, soft spots, and/or sharp edged materials are encountered, the bottom shall be excavated for an additional 3 inches and filled and tamped level with the original bottom with sand or earth free from particles that would be retained on a 1/2-inch sieve.

7.2.3 Backfilling: Backfilling shall be in layers not more than 8 inches deep and shall be thoroughly tamped. The first layer shall be earth or sand, free from particles that would be retained on a 1/4-inch sieve and extending not less than 3 inches above the top of the cables. The succeeding layers shall be excavated material having stones no larger than would pass through a 4-inch ring. The backfill may be moistened. The backfill shall be level with the adjacent surface except that in sodded areas a space equal to the thickness of the sod shall be left.

7.2.4 Reconditioning of Surface: The surface disturbed during the installation of duct or cable shall be restored to its original elevation and condition. Sod or topsoil shall be preserved carefully and replaced after the backfilling is completed. Sod that is damaged shall be replaced by sod of a quality equal to that removed. Where the surface is disturbed in a newly seeded area, the restored surface shall be re-seeded with the same quantity and formula of seed as that used in the original seeding.

7.2.5 Special conditions: During the installation of all conduit lines, the streets must be kept open to traffic. The Contractor shall plan and execute his work to meet this condition. At locations where duct lines cross railroad tracks and the work requires closing of the tracks, the Contractor must secure permission from the Contracting Officer for each track closure.

7.3 Installation of Overhead Systems:

7.3.1 Overhead Pole Lines: Overhead pole lines shall conform to the requirements of the National Electrical Safety Code for grade "B" construction, medium loading and as further specified herein. All streets, alleys, roads, and drives shall be considered "Public." Pole configurations shall be as indicated, conforming to LANTDIV Pole Plates, Nos. 16-3, 11, 14, 15, 18, 20, and 21.

7.3.2 Pole Setting: In normal firm ground, minimum pole setting depths shall be as listed in the following table. Poles in straight runs shall be in a straight line. Adjacent poles shall be with gains facing in opposite directions. Every second pole shall have crossarms facing in same direction. Poles shall be set to maintain as even a grade as practicable. When the average ground run is level, consecutive poles shall not vary more than 5 feet in height. When ground is uneven, poles differing in length shall be kept to a minimum by locating poles to avoid the highest and lowest ground points. If it becomes necessary to shorten a pole, a piece shall be sawed off the top and the shortened end of the pole given an application of hot preservative. Holes shall be dug large enough to permit the proper use of tampers to the full depth of the hole. Backfill shall be placed in the hole in 6-inch maximum layers, and thoroughly tamped. Surplus earth shall be placed around the pole in a conical shape and packed tightly to drain water away.

7.3.2.1 Table of Pole-Setting Depths:

Length Overall (feet)	Setting Depth, Minimum (feet and inches)	
	Straight Lines	Curves, Corners, and Points of Extra Strain
35	6-0	6-0

7.3.3 Line Conductors: Conductors having a potential in excess of 600 volts shall be carried on separate crossarms or supports above conductors having a lower potential and shall not be installed over buildings. Sag and tension chart shown on the plans shall be used for the installation of all pole-line conductors. Conductor sags shall adhere as closely as possible to the values given in the chart but may be adjusted where required by proximity of other existing circuits to provide ample clearance between conductors. Changes in the values of sag shall be subject to the approval of the Contracting Officer.

7.3.4 Guys and Anchors: Guys shall be installed on corner poles at points of change in line direction, at ends of lines, and on adjacent brace poles at railroad and main highway crossings. Strain insulators shall be attached to guys by means of 3-bolt guy clamps, wire rope clips, or preformed gripping devices. Guy anchors shall be installed with anchor rods in direct line with the guy and load to be supported. Anchors shall be located at a distance from the base of the pole at least 1/2 the height of the guy attachment.

7.3.5 Circuit Protective Apparatus: Pole-type lightning arresters and fuses shall be provided on primary lines at all aerial-to-under ground connections, dead ends, and transformers and at other locations where indicated. The devices shall be coordinated with the system to which they are connected. Automatic circuit reclosers and automatic line sectionalizers shall be provided where indicated.

7.3.6 Cable Risers on Poles: Cable risers on poles, other than grounding conductors, shall be installed in conduit. The conduit for cable risers shall be encased in concrete to a point 6 inches above finished grade. The conduit shall be of the rigid metal type as hereinbefore specified. Conduit shall be secured to the pole by means of suitable clamps or straps spaced not over 4 feet apart.

7.4 Splices in Wires and Cables: All splices shall be in accessible locations. Tapes shall be as specified hereinbefore. Splices in control cables shall be made by splicers having not less than three years experience in splicing such cables; the Contractor shall furnish satisfactory evidence of such experience as specified hereinbefore.

7.4.1 **Splices in Insulated Power and Lighting Wires and Cables Without Metallic Sheath:** Conductors shall be joined securely both mechanically and electrically by one of the following methods: (1) twisting the conductors together and soldering, (2) twisting the conductors and forming a "Western Union" joint, (3) Exothermic weld process, or (4) by the use of solderless connectors. Insulating tapes, hotmolded composition covers, or other approved equivalent, having an insulation value equivalent to the conductor insulation may be used for splices in cables rated 600 volts and below. Splices in rubber- or cross-linked polyethylene-insulated, neoprene- or cross-linked polyethylene-jacketed wires and cables shall be the cast type, watertight taped type, tape-over-cast type, vulcanized type, or other approved type as indicated or specified. The work shall be in accordance with the recommendations of the manufacturer of the wires, cables, and/or splicing materials. All splices shall be suitable for the rated insulation level of the cable.

(1) **Epoxy cast-type splice:** The insulation shall be provided by means of a molded casting process employing a thermosetting epoxy resin insulating material. The resin material shall be applied by a gravity poured method or by a pressure injected method. The component materials of the resin insulation shall be in a packaged form ready for convenient mixing without removing from the package. The gravity poured method shall not be used for splices in shielded cable.

(2) **EPR cast-type splice:** The insulation shall be provided by means of a molded casting process employing an ethylene propylene rubber (EPR) splicing compound which results in an inseparable bond between the splicing material and the cable insulation. The molding process shall include injection of the molding material into the mold so as to insure void free splices.

(3) **Watertight Taped Type Splice:** The splice shall consist of an approved connector, self-fusing tape (splicing compound), self-bonding semi-conducting tape, tinned copper shielding tape or braid, and plastic tape.

(4) **Tape-Overcast Type Splice:** This splice shall be as specified hereinbefore for the watertight taped type, overcast with an epoxy resin construction as specified hereinbefore for the cast type, pressure method. This splice shall be suitable for the rated voltage of the cable, to a limit of 15 kv.

(5) **Vulcanized Type Splice:** The vulcanizing process shall be a heat-pressure process of an approved type and employing materials and equipment suitable for the type and voltage of cables for which it is used. Materials used in the splicing process shall be fully and permanently compatible with materials in the cables. This splice shall be suitable for the rated voltage of the cable, to a limit of 5 kv.

7.4.2 Splices in Overhead Line Conductors: Splices in overhead line conductors shall be made with twist sleeve or compression type connectors. Splices in insulated conductors shall be covered with an insulation equivalent to that of the conductors and an approved weather-proof tape overall.

7.5 Termination of Insulated Power and Lighting Cables: All insulated power and lighting cables shall be properly terminated. Terminations shall be made by adequately trained personnel, using methods and materials suitable for the work as necessary and as specified hereinafter, and in accordance with the recommendations of the manufacturer of the cable and/or terminating materials or kit. Such recommendations, accompanied by suitable detail drawings, shall be submitted to the Contracting Officer for approval. Terminations of cable for service exceeding 600 volts shall be made by personnel having not less than 3 years experience as a licensed electrician, including adequate experience in the splicing or terminating of high-voltage insulated cable; the experience shall be certified and approved by the Contracting Officer. Terminations and/or terminating devices shall be capable of withstanding the tests specified for the cable installations. Terminations of single- and multi-conductor cables shall include the securing and sealing of the sheath and insulation of the cable conductors, stress relief and grounding of cable shields of shielded cable, and grounding of neutral conductors, metallic sheaths, and armor. Cables and cable terminations shall be adequately supported so as to avoid any excessive strain on the termination and conductor connection.

7.6 Protection of Wire and Cable Ends: The ends of wires and cables in manholes, handholes, vaults, and in other wet location as defined by the National Electrical Code that are not to be spliced or connected to equipment shall be protected from moisture and other damage by line end caps suitable for the rated insulation level of the cable.

7.7 Grounding: Grounding shall be in accordance with the National Electrical Code and the National Electrical Safety Code except that grounds and grounding systems shall have a resistance to solid earth ground not exceeding the following values:

	<u>Ohms</u>
For grounding other metal enclosures of primary voltage electrical and electrically operated equipment	10
For lightning arrester grounds on pole line distribution systems	10
For grounding secondary distribution systems (neutral) non-current carrying metal parts associated with distribution systems	10
For grounds not covered above	10

When work in addition to that indicated and specified is directed, in order to obtain the specified resistance to ground, the provisions of the contract respecting an adjustment for changed conditions shall apply.

7.7.1 Ground Rods: Approved copper-alloy clamp shall be brazed to the upper end of ground rods, and ground wires shall be securely attached thereto by means of a bolted connection. Ground rods shall be driven to a depth of not less than 11 feet and shall have diameters sufficient to permit driving to necessary depth without being damaged, but in no case shall the diameter be less than hereinbefore specified.

7.7.2 Welded or Brazed Connections: Joints in grounding conductors and mats shall be welded or brazed. The welding or brazing processes shall not in any way cause the parts joined to be damaged or weakened and shall join all strands. The welding process shall be an exothermic type, and the completed connection or joint shall be equal or larger in size than the conductors joined. The brazing process shall be in accordance with MIL-B-7883.

7.7.3 Ground Cable Crossing Expansion Joints: Ground cables crossing expansion joints or similar separations in structures and pavements shall be protected from damage by means of suitable approved devices or methods of installation which will provide the necessary slack in the cable across the joint to permit movement. Stranded or other approved flexible copper cable run or jumper shall be used across such separations.

7.7.4 Grounding for Overhead Pole Lines: Grounding shall conform to the National Electrical Safety Code, except that the resistance to ground of the ground system shall not exceed 10 ohms. The grounding terminal of each lightning arrester, the tank of each transformer, the operating mechanism of pole-top switches, cable messengers, non-current carrying parts of equipment, and the neutrals shall be solidly interconnected and connected to ground. Grounding conductors shall be soft-drawn copper, having a current capacity of at least 20 percent of that of the largest conductor to which it is connected, but not smaller than No. 6 AWG and not smaller than indicated on the drawings. Lightning arresters shall be grounded with a conductor of soft-drawn copper not smaller than No. 4 AWG. All connections shall be made with solderless connectors or by the molded fusion-welding process. Ground conductors shall be connected to a copper-clad-steel ground rod not less than 3/4 inch in diameter by ten feet long. The ground rod shall be driven at least 11 feet into the ground. Where this condition cannot be obtained with one rod driven 11 feet in the ground, a longer rod, deep-driven section rods, or additional rods shall be provided, until, the required ground resistance is obtained, except that not more than three 10-foot ground rods will be required. Grounding conductors shall be protected by half-round plastic or fiber molding securely mounted and extending not less than 8 feet above grade and throughout the communication and transformer spaces.

7.7.5 Grounding and Bonding Equipment: Grounding and bonding equipment, except as indicated or specified otherwise shall conform to UL publication No. 467.

8. FIELD TESTS: The Contractor shall provide all labor, equipment and incidentals required for testing, except that the Government will provide electric power required for the tests. All defective material and workmanship disclosed as the result of the tests given herein shall be corrected by the Contractor at no cost to the Government. The Contractor shall show by demonstration in service that all circuits and devices are in good operating condition. Tests shall be such that each item of control equipment will function not less than five times.

8.1 Insulation resistance test for systems 600 volts and less: After all wiring is completed and connected ready for operation, but prior to placing systems in service and before any branch circuit breakers are closed, insulation resistance tests shall be made in all feeder and subfeeder circuits. The insulation resistance between conductors and between each conductor and ground shall be measured. Measurements shall

be made with an instrument capable of making measurements at an applied potential of 500 volts. Readings shall be taken after the voltage has been applied for a minimum of one minute. The minimum insulation resistance for circuits of No. 12 AWG conductors shall be 1,000,000 ohms. For circuits of No. 10 AWG or larger conductors, a resistance based on the allowable ampacity of the conductor as fixed by NFPA 70 shall be as follows:

25 through 50 amperes	250,000 ohms
51 through 100 amperes	100,000 ohms
101 through 200 amperes	50,000 ohms
201 through 400 amperes	25,000 ohms
401 through 800 amperes	12,000 ohms
Over 800 amperes	5,000 ohms

8.2 Ground Resistance Tests: Grounding system shall be tested to assure continuity and compliance with the requirement that ground resistances not exceed the values hereinbefore specified. Ground resistance measurements of each ground rod shall be taken and certified by the Contractor. Upon completion of the project, the Contractor shall submit in writing to the Contracting Officer, the measured ground resistance of each ground rod and grounding system, indicating the location of the rod and grounding system, as well as the resistance and soil conditions at the time the measurements were made. Ground resistance measurements shall be made in normally dry weather, not less than 48 hours after rainfall, and with the ground under test isolated from other grounds. Ground resistance shall also be measured from each piece of equipment to the ground electrode and shall not exceed three (3) ohms.

---o0o---

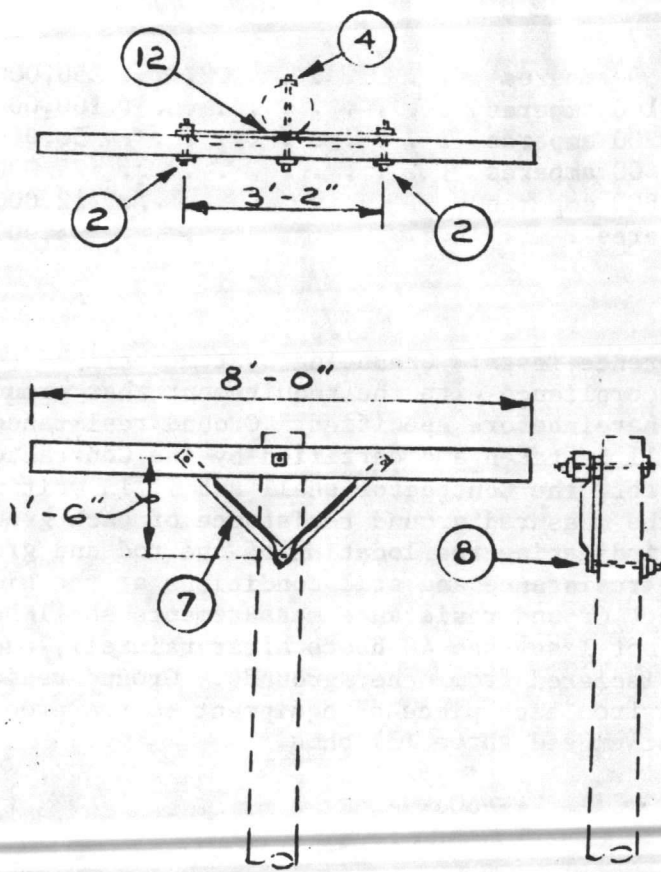

X - AB & X - AB - GAIN

LANTDIV PLATE 16-3

NOTE - FOR 15-50 KV USE (52) IN PLACE
OF (11) AND (61) IN PLACE OF (10)

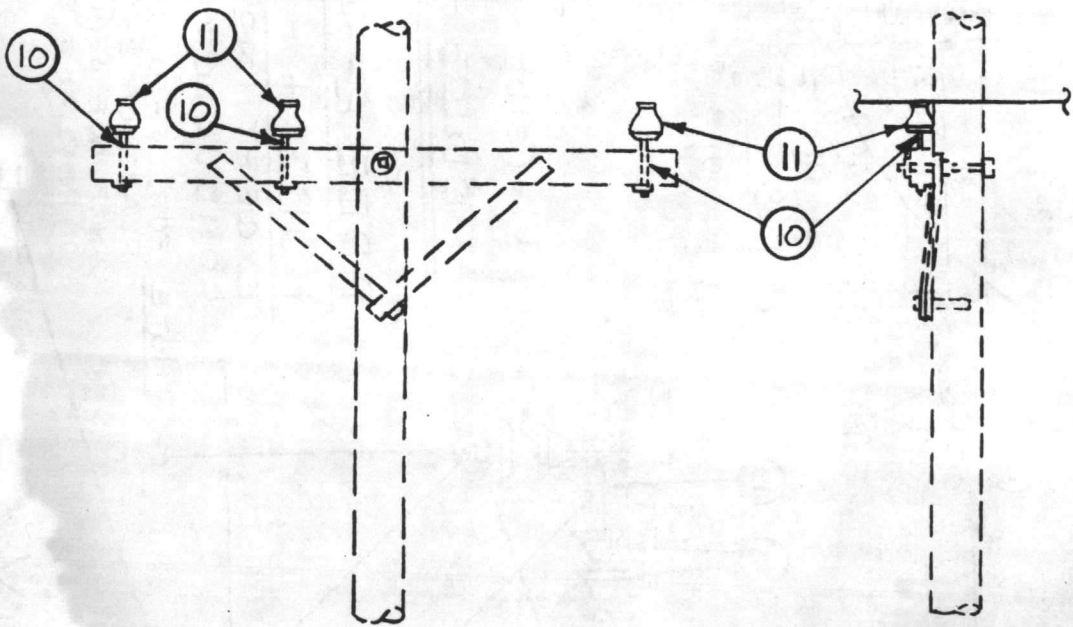

F 3

F1, F2, F4 & F5 SAME
EXCEPT FOR NO. OF CONDUCTORS

LANTDIV PLATE 16-11

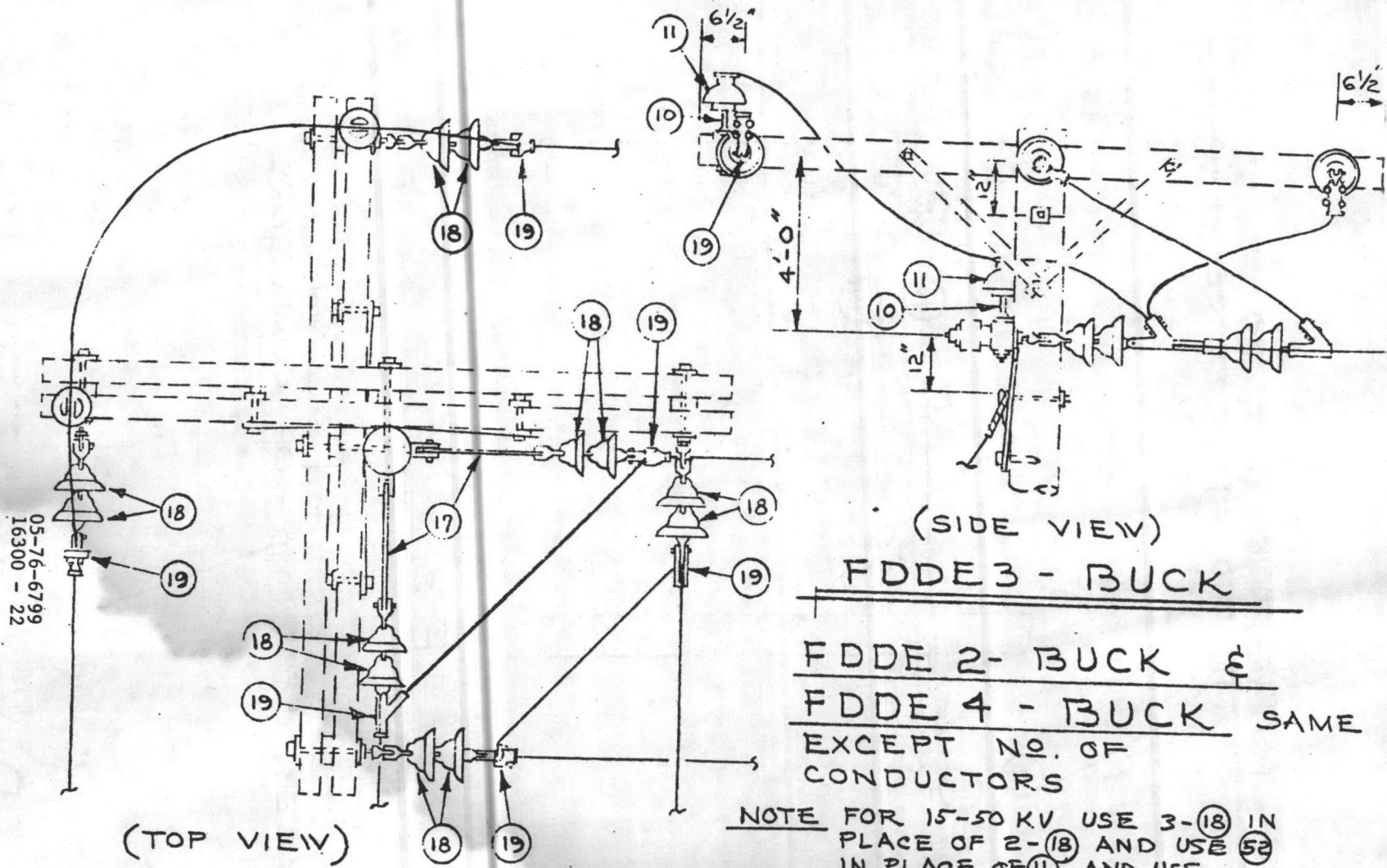

05-76-6799
16300 - 22

(TOP VIEW)

(SIDE VIEW)

FDDE3 - BUCK

FDDE 2 - BUCK &
FDDE 4 - BUCK SAME
EXCEPT NO. OF
CONDUCTORS

NOTE FOR 15-50 KV USE 3-(18) IN
PLACE OF 2-(18) AND USE (52)
IN PLACE OF (11) AND USE
(61) IN PLACE OF (10)

LANTDIV PLATE 16-14

3-75

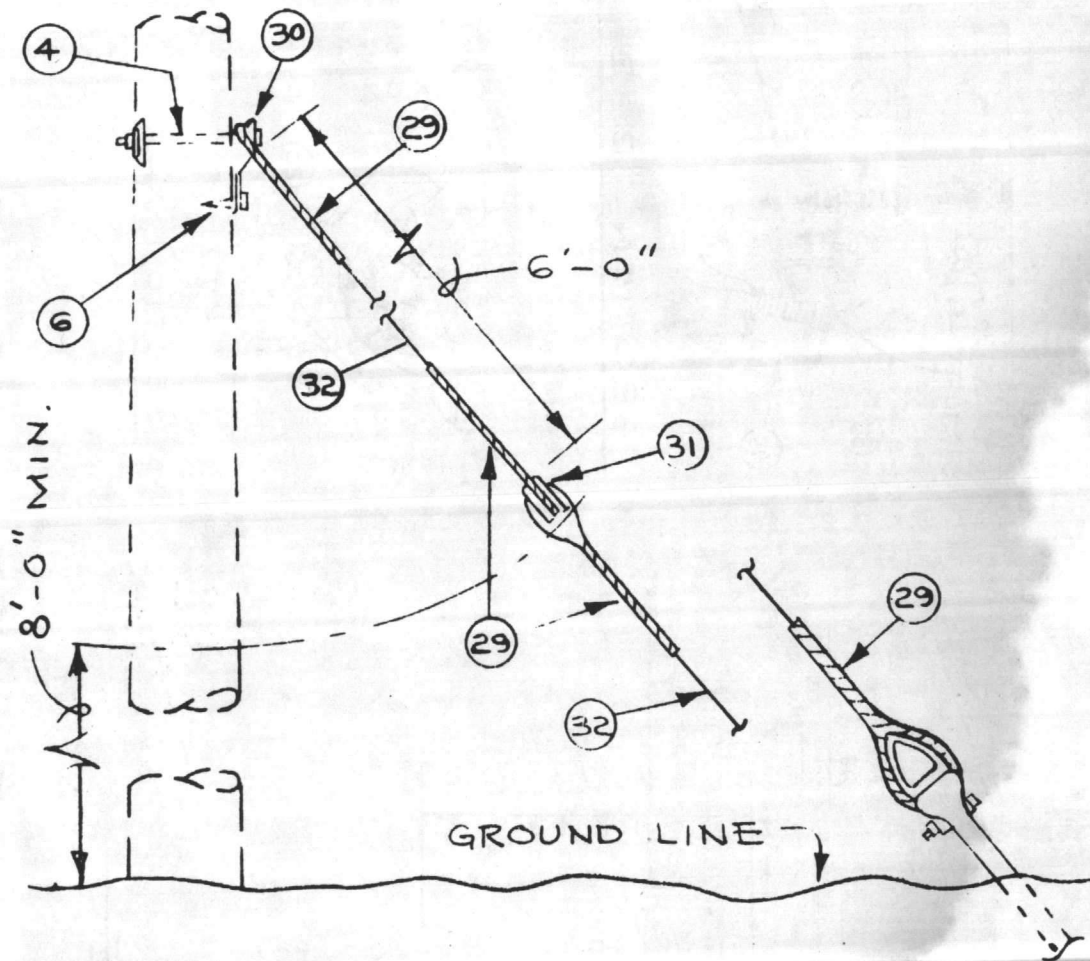

GUY
 (SIZE AS SPECIFIED)

LANTDIV PLATE 16-18

3-75

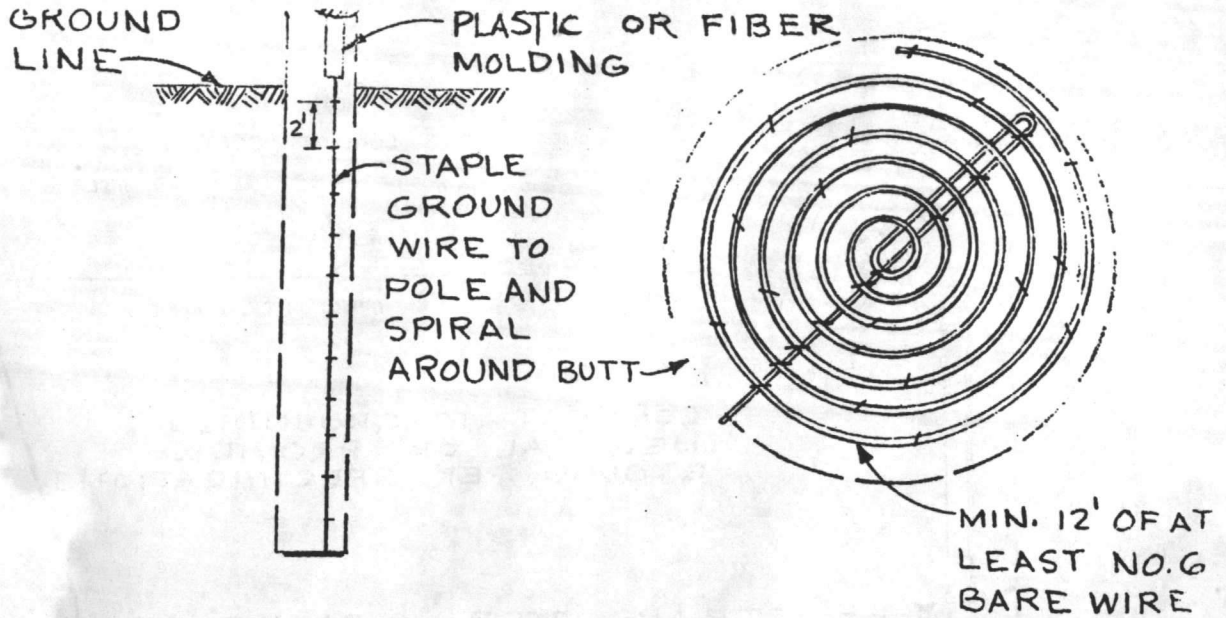

ELEVATION

BUTT VIEW

COIL TYPE GROUND - (FOR USE WHERE GROUND RESISTANCE IS LOW)

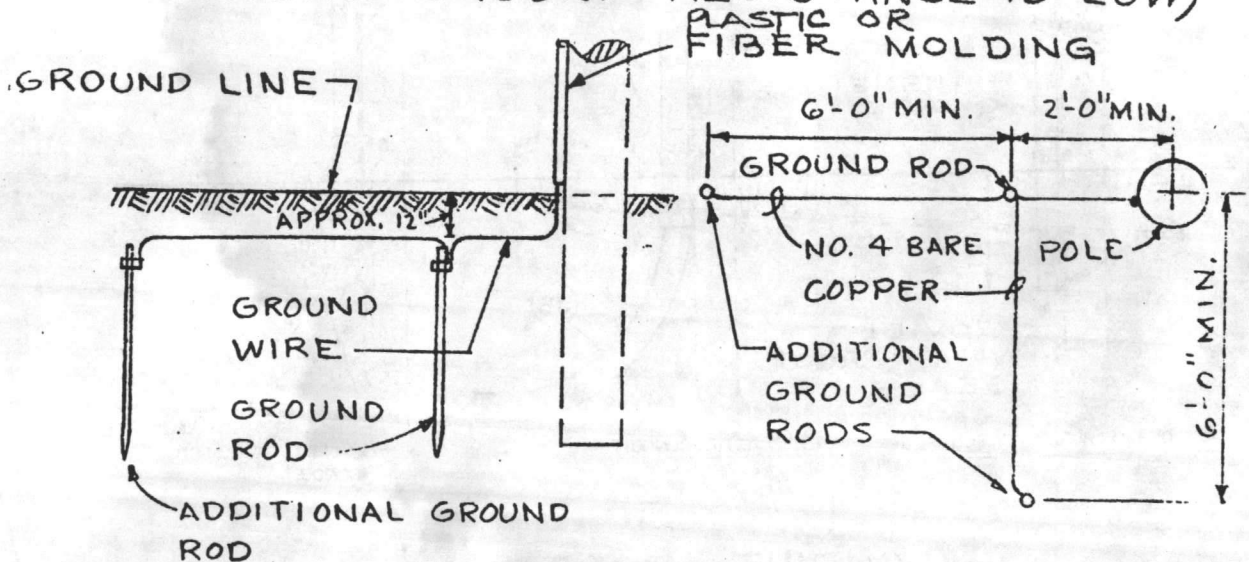

ELEVATION

PLAN

GROUND ROD CONNECTION (USE ADDITIONAL RODS WHERE EARTH RESISTANCE IS HIGH.)

GROUNDING

LANTDIV

PLATE NO. 16-20

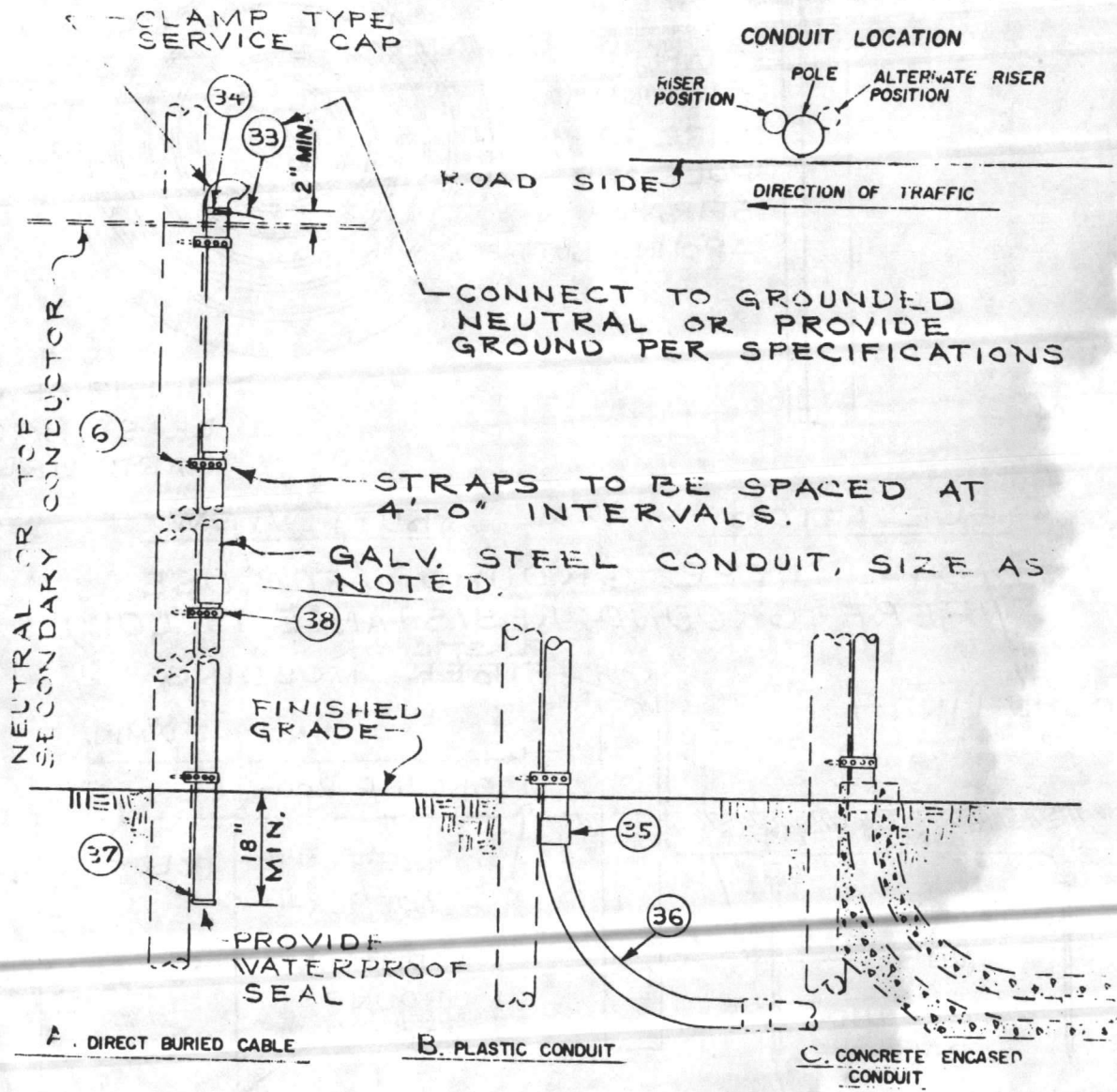

CONDUIT RISER
(SIZE AS INDICATED)

LANTDIV PLATE 16-21

3-75

SECTION 16402
INTERIOR ELECTRICAL SYSTEMS

1. APPLICABLE PUBLICATIONS: The following publications of the issues listed below, but referred to thereafter by basic designation only, form a part of this specification to the extent indicated by the references thereto (where a number is suffixed to the specification number, it denotes the effective amendment to the specification):

1.1 Federal Specifications:

TT-E-489E	Enamel, Alkyd, Gloss, (for exterior and interior surfaces).
FF-D-645	Primer, Paint, Zinc-Chromate, Alkyd Type.
W-C-375B	Circuit Breaker, Molded Case, Branch Circuit and Service.
W-C-596D	Connector, Plug, Electrical; Connector, Receptacle, Electrical.
W-S-865C & Int Am 2	Switch, Box (Enclosed), Surface-mounted.

1.2 Military Specifications:

MIL-P-15328C(1)	Primer, Pretreatment (Formula No. 117 for Metals).
-----------------	--

1.3 LANTDIV Plates:

Light Fixtures Nos. 16-I-1	Dated 6-76
-------------------------------	------------

1.4 American National Standards Institute (ANSI):

C2-1973	National Electrical Safety Code.
C80.1-1966 (R 1971)	Rigid Steel Conduit, Zinc Coated.

1.5 National Electrical Manufacturers Association (NEMA):

ICS-1970(JUL 75)	Industrial Controls and Systems.
FU 1-1966	Low Voltage Cartridge Fuses.
MG 1-1972(AUG 75)	Motors and Generators.

1.6 National Fire Protection Association (NFPA):

70-1975 National Electrical Code (NEC).

1.7 American Society for Testing and Materials (ASTM):

B 1-70 Hard Drawn Copper Wire.
B 8-72 Concentric-Lay Stranded Copper Conductors; Hard,
Medium-Hard, or Soft.

1.8 Underwriters' Laboratories, Inc. (UL):

1-1973(AUG 73) Flexible Steel Conduit.

20-1974 Snap Switches.
50-1970(JUN 74) Cabinets and Boxes.
57-1972(APR 74) Electric Lighting Fixtures.
67-1974(OCT 74) Panelboards.
83-1971(APR 74) Thermoplastic-Insulated Wires.
198-1971(AUG 72) Fuses.
467-1972(APR 74) Grounding and Bonding Equipment.
486-1969(DEC 73) Wire Connectors and Soldering Lugs.
510-1971(JUN 71) Insulating Tape.
514-1974(DEC 74) Outlet Boxes and Fittings.
719-1971(APR 74) Service-Entrance Cables.

869-1974(AUG 74) Service Equipment.

2. QUALITY CONTROL: All field tests to determine conformance with the specified requirements shall be performed in the presence of the Contracting Officer.

3. SUBMITTALS:

3.1 Shop drawings (SD) and catalog data (CD) for the following items shall be submitted to and approved by the Contracting Officer approved by the Contractor Quality Control Representative and submitted to the Contracting Officer for record purposes prior to the delivery of these items to the project site. The drawings and data shall show materials, finish and all pertinent details.

3.1.1 For Contracting Officer Approval:

Wireway (SD)	Panelboards (SD, CD)
Receptacles (CD)	Circuit Breakers (CD)
Conductors (CD)	Disconnect Switches (CD)
Fuses (CD)	Contactors (CD)
	Lighting Fixtures (CD)
Conduit Supports (CD)	

3.2 Manufacturer's Certifications shall be submitted to the Contracting Officer for the following items prior to the delivery of these items to the project site. Certifications shall indicate complete compliance with specification requirements.

Conduit	Boxes	Toggle Switches
Conduit Fittings	Outlets	Tapes
Ground Rods	Cover and Device Plates	

3.3 Materials tests and test reports: The testing requirements for materials incorporated in referenced documents will be waived provided the manufacturer submits notarized certificates stating that previously manufactured materials have been tested by recognized laboratories, that such materials meet testing requirements specified, and that the materials furnished for this project are of the same type, quality, manufacture and make as that tested. Copies of the test reports need not be submitted except as specifically requested by the Contracting Officer.

4. GENERAL REQUIREMENTS: The work includes the provision of new interior electrical systems. Each system shall be complete and ready for operation according to the requirements specified herein. The contract drawings indicate the extent and general arrangement of equipment, fixtures, and conduit and wiring systems. If any departures are deemed necessary by the Contractor, details of such departures and the reasons therefor shall be submitted as soon as practicable and within 30 days after award of the contract to the Contracting Officer for approval. No such departure shall be made without prior written approval of the Contracting Officer. The Contractor shall be responsible for providing properly sized circuit breakers to serve equipment and motors furnished which differ from those specified or indicated. This shall be further understood to include branch circuit wiring, conduit, disconnect switches, etc., in accordance with the appropriate codes and specifications. The cost of providing this increased electrical service and related work shall be included under the applicable section under which the equipment and motors are being furnished. In each of the standards referred to herein, the advisory provisions shall be considered to be mandatory, as though the word, "shall" had been substituted for "should" wherever it appears. Reference in these standards to the "authority having jurisdiction", or words of similar meaning, shall be interpreted to mean the Contracting Officer.

4.1 Product Requirements: Unless otherwise indicated, the materials to be provided under this specification shall be the products of manufacturers regularly engaged in the production of such items and shall be the manufacturer's latest design. The products shall conform to the applicable standards of UL and NEMA, unless specified otherwise. All items of the same type or ratings shall be identical. This shall be further understood to include products with the accessories indicated. All equipment and materials shall be new unless indicated or specified otherwise. The

Contractor shall submit proof, if requested by the Contracting Officer, that the materials, appliances, equipment or devices that he provides under this contract, meet the requirements of the Underwriters' Laboratories, Inc., as regards fire and casualty hazards. The label of, or listing by, the Underwriters' Laboratories, Inc., will be accepted as conforming with this requirement. In lieu of the label or listing, the Contractor may submit independent proof satisfactory to the Contracting Officer that the materials, appliances, or devices conform to the published standards, including methods of test, of the Underwriters' Laboratories, Inc.

4.2 Material Handling: Material arriving on job site shall be stored in such a manner as to keep material free of rust and dirt and so as to keep material properly aligned and true to shape. Rusty, dirty, or misaligned material shall be rejected. Electrical conduit shall be stored to provide protection from the weather and accidental damage.

Cables shall be sealed, stored and handled carefully to avoid damage to the outer covering or insulation and damage from moisture and weather. Adequate protection shall be required at all times for electrical equipment and accessories until installed and accepted. Materials damaged during shipment, storage, installation or test shall be replaced or repaired in a manner meeting with the approval of the Contracting Officer.

4.3 All electrical components shall be waterproofed by use of total enclosure, gaskets or seals and by other acceptable means as required.

5. ELECTRICAL SERVICE FOR BUILDINGS: Building service: 120/208-volt, 3-phase, 4-wire, Y-connected alternating current (60 hertz). Final connections to the power distribution system shall be made by the Contractor as directed by the Contracting Officer.

5.1 Service into Buildings: Underground conduit for service feeders shall be rigid steel as indicated. The underground portion of the conduit shall be encased in a concrete envelope having a wall thickness of not less than three inches and shall be buried not less than 24 inches. Where a conduit enters through a concrete floor, the curved portion shall not be visible above the finished floor, and the entire conduit below the floor slab shall be encased in a concrete envelope having a wall thickness of not less than three inches. Where underground service connections enter a building above the ground floor, a suitable pull box shall be installed.

5.2 Service entrance equipment shall conform to UL 869 and W-S-865, as applicable.

6. MATERIALS AND EQUIPMENT:

6.1 Conduit and Fittings:

6.1.1 Metal Conduit: Metal conduit shall be zinc coated rigid steel conforming to ANSI C80.1.

6.1.2 Flexible galvanized steel conduit shall have an extruded moisture and oil-proof PVC jacket for installation where indicated and in areas subject to abnormal moisture. Watertight connectors shall be used with PVC covered conduit.

6.1.3 Conduit Fittings: Fittings for rigid metal conduit, nonmetallic conduit, and flexible metal conduit shall conform to UL 467 and UL 514, as applicable. Fittings shall be of the same manufacture as the conduit. Fittings for all conduit installed in this contract shall provide a watertight joint.

6.1.4 Wireway: Rigid steel wiring troughs shall be square in shape, constructed of steel, totally enclosed with hinged cover or cover fastened with screws, and sized as required by NFPA 70. The wireway shall be provided complete with all necessary accessories and fittings and shall be watertight.

6.2 Boxes and Outlets: Boxes shall conform to UL 514. Boxes shall be provided in the wiring or raceway systems wherever required for pulling of wires, making connections, and mounting of devices or fixtures. Boxes for metallic raceways shall be of the cast metal hub type suitable for use in normally wet locations. Boxes shall be sized and installed according to the National Electrical Code.

6.2.1 Boxes for use with raceway systems shall not be less than 1-1/2 inches deep except where shallower boxes, required by structural conditions, are approved. Boxes for other than lighting-fixture outlets shall be not less than 4 inches square except that 4 inch by 2 inch boxes may be used where only one raceway enters the outlet. Boxes less than 4 inches for mounting lighting fixtures may be installed as required by fixture configuration, as approved.

6.3 Receptacles:

6.3.1 Weatherproof receptacles shall be as specified herein and shall be provided with a cast metal box with a gasketed, weatherproof, cast metal cover plate and a cap over each receptacle opening. The cap(s) shall be provided with a spring-hinged flap. Receptacles shall be duplex, grounding type conforming to W-C-596 and rated 20 amperes, 125 volts. Bodies shall be brown thermosetting plastic composition, supported on a metal mounting strap. Receptacles shall be side-wired with winding type terminals. The grounded pole shall be connected to the mounting strap.

6.4 Toggle Switches: Toggle switches shall conform to UL 20 and shall be totally enclosed with bodies and handles of brown thermosetting plastic and a mounting strap. Wiring terminals shall be of the screw type, side wired. Backwired clamp-type terminals are not acceptable. Switches shall be rated quiet type, AC only, 20 ampere, 120-277 volt, as indicated.

6.4.1 Weatherproof switches shall be the same as those specified hereinbefore, provided in weatherproof enclosures with external operating handles.

6.5 Wires and Cables: Conductor sizes are expressed in American Wire Gage (AWG) or in circular mils. Minimum conductor size shall be No. 12 AWG except control wires and cables shall be minimum No. 19 AWG. Wires No. 8 and larger shall be stranded. Conductors shall be copper.

6.5.1 Grounding Conductors: Conductors for grounding, bonding and other uses requiring bare copper wire shall be solid bare copper wire conforming to ASTM B1 for sizes No. 8 AWG and smaller, and shall be stranded bare copper wire conforming to ASTM B8, class B, for sizes No. 6 AWG and larger.

6.5.2 Power and lighting wires and cables shall be type THW or THWN conforming to UL 83.

6.5.3 Underground Secondary Circuits: The underground secondary conductors shall be single conductor, type USE conforming to UL 854, rated not less than 600 volts. Cable shall be suitable for direct burial or conduit installation and shall be free from splices from one junction box to another.

6.5.4 Color Coding: All secondary service, feeder, branch and control circuit conductors shall be color-coded. Conductor identification shall be provided within each enclosure where a tap, splice or termination is made. Conductor identification shall be by color coded insulated conductors, plastic coated self sticking printed markers, colored nylon cable ties and plates, or heat-shrink type sleeves. Control circuit terminations shall be properly identified.

Colors to be used in coding shall be:

208 VOLT SYSTEM

Neutral - White
Phase A - Black
Phase B - Red
Phase C - Blue
Grounding Conductor - Green

6.5.5 Controls including relays and wiring shall be as specified in Section: "Electrical Distribution, Exterior".

6.6 Splices and Terminations shall conform to UL 486. Tapes for splices and terminations shall conform to UL 510. Connections in wires No. 10 AWG and smaller shall be made with insulated pressure type connectors or wirenut type connectors. Splices for wires No. 8 AWG and larger shall be made with a solderless connector.

6.7 Panelboards shall conform to UL 67 and UL 50, as applicable. Panelboards shall be factory assembled automatic circuit breaker type. Wiring gutters on panelboards

05-76-6799

16402 - 6

having through feeders shall be 5 inch minimum. Panelboards shall not exceed 78 inches in height. Panelboard shall be made of cold rolled sheet steel in accordance with gauges as required by the Underwriters' Laboratories. All trim shall have door equipped with flush type combination lock and catch, three milled type keys being supplied with each lock. Each lock shall be keyed same as lock on other panelboards. Provide panel with typewritten index card and transparent cover in frame on inside of door, indicating circuit control. Panelboards shall be weatherproof (NEMA - 3R).

6.7.1 Buses for panelboards: An insulated neutral bus for each panel for connection of both feeder and branch circuit neutral wires shall be provided. A separate ground bus, bonded to the steel cabinet, shall be provided for each panel connection of all ground wires and shall be marked with a green stripe along the front of the bus. Bus bars shall be copper and shall be securely fastened to bases and shall not depend upon breakers for support. All main buses and back pans shall be so designed that branch circuits may be changed without additional machining, drilling, or tapping.

6.7.2 Circuit Breakers shall conform to W-C-375, type II and shall have a minimum interrupting capability of 10,000 amperes symmetrical. All breakers shall be designed to accept copper, copper-clad, and aluminum conductors. Multipole circuit breakers shall be of the common-trip type having a single operating handle. Plug-in type circuit breakers are not acceptable. All multipole breakers shall be so designed that an overload in one pole automatically causes all poles to open. Any three adjacent breaker poles shall be connected to Phases A, B, and C respectively and that same relationship of phase sequence shall be maintained. Complete panelboard assembly shall be so designed that any individual breaker can be removed without disturbing adjacent units or without loosening or removing supplemental insulation supplied as a means of obtaining clearances and other requirements of the Underwriters' Laboratories.

6.7.3 Panelboard Submittals: Before manufacturing, drawings shall be submitted showing dimensions of panelboard cabinets, gutter space, gage and trim, main bus and terminal ratings, manufacturer's name and type of breakers, and details of construction of the panelboards to determine compliance with the specification.

6.8 Disconnect switches shall be normal duty fused single throw, quick-make quick-break, 3 pole, 250 volts, NEMA Type 4 enclosed unless otherwise indicated. Switch shall have no cover interlock. Switches serving as motor-disconnect means shall be horsepower rated in conformance with Table III of W-S-865.

6.9 Fuses shall conform to NEMA FU-1 and UL 198. A complete set of fuses for all switches shall be provided. Time-current characteristic curves of fuses serving motors or connected in series with circuit breakers shall be coordinated for proper operation. Fuses shall have voltage rating not less than the circuit voltage.

6.9.1 Cartridge fuses, dual-element time-lag type, shall be nonrenewable with an interrupting rating not less than 200,000 amperes. At 500 percent current, time lag fuses shall not blow in less than 10 seconds. Dual-element time-lag fuses shall be used for circuits rated in excess of 30 amperes or 125 volts, except where current-limiting fuses are indicated.

6.10 Motors and controllers shall conform to the latest applicable standards of the NEMA for type, class and size as specifically applied, Where control voltages differ from motor voltage, a control voltage transformer shall be provided in and as part of the starter. The approximate size of each motor is shown on drawings. Check size and characteristics of all motors to insure that correctly sized starters and overload heaters are provided for the motors installed.

6.10.1 Motors shall conform to NEMA MG-1 and shall be of sufficient size for the duty to be performed and shall not exceed their full load nameplate current rating when driven equipment is operated at specified capacity under the most severe conditions likely to be encountered. Motors provided for operation on 208 volt 3 phase circuits shall have a voltage rating of 200 volts. All motors shall be designed to operate at full capacity with a voltage variation of plus or minus 10 percent of the motor voltage rating and shall be capable of starting with a transient voltage dip of at least 25 percent below normal operating voltage with normal starting load for the required application. Motors shall be suitable for across-the-line starting.

6.10.2 Motor controllers shall conform to NEMA ICS. Motor controllers or starters and controls shall be furnished as part of the equipment on which they are used. Each type of controller shall contain thermal running overload protection and manual reset means. All starters and controls shall be NEMA 3R enclosed. Manual starters shall be three pole type designed for surface mounting.

6.10.3 Selector Switch: The controller shall have a hand-off-automatic selector switch. Connections to the selector switch shall be such that only the normal automatic regulatory control devices will be bypassed when the switch is in the "hand" position. All safety control devices, such as high temperature cutouts and motor overload protection devices shall be connected in the motor control circuit in both "hand" and "automatic" positions.

6.10.4 Combination starters with fusible disconnect switch in the same enclosure shall be furnished where indicated. Starters for motors without automatic control shall have built-in "start-stop" pushbuttons. Starters for motors under automatic control shall have built-in "hand-off-auto" selector switch. Pushbutton stations shall have "start-stop" momentary contacts, having one normally-open and one normally-closed set of contacts, with ruby indicating lights to indicate when motors are running. Stations shall be heavy-duty type designed for flush or surface mounting, as required. Pilot and indicating lights shall be neon type.

6.11 Grounding and Bonding: Grounding and bonding equipment shall be in accordance with UL 467.

6.11.1 Equipment grounds: A green-colored equipment grounding conductor which shall be separate from the electrical system neutral conductor shall be provided. Equipment ground conductors shall be provided in all branch circuits serving convenience outlets, receptacles, portable and permanently installed electrical appliances, equipment, apparatus and other miscellaneous metal-enclosing bodies including light switch boxes normally within contact of personnel.

6.11.2 Ground rods shall be rolled to a commercially round shape from a welded copper-clad steel manufactured by the molten-welding process or by the electro-formed process (molecularly bonded). They shall have an ultimate tensile strength of 75,000 pounds per square inch (psi) and an elastic limit of 49,000 psi. The rods shall be not less than 3/4 inch in diameter by 10 feet in length and shall have a hard, clean, smooth, continuous copper surface and the proportion of copper shall be uniform throughout the length of the rod. The copper shall have a minimum wall thickness of 0.013 inch at any point on the rod.

6.12 Lighting Fixtures: Lighting fixtures shall conform to UL 57, shall be as indicated, shall be as shown on LANTDIV Plates Nos. 16-I-1 and shall be provided complete with lamps of the number, type and wattages shown. The details, shapes and dimensions are indicative of the general type desired, but are not intended to restrict selection to fixtures of any particular manufacturer. Fixtures of similar designs and equipment, light-distribution and brightness characteristics, and of equal finish and quality will be acceptable as approved by the Contracting Officer.

7. INSTALLATION: Electrical installation shall conform to the National Electrical Safety Code, the National Electrical Code and to the requirements specified herein.

7.1 Conduit, Fittings and Support:

7.1.1 Use of Specific Types: Aluminum conduit shall not be installed. Electrical metallic tubing shall not be used. Flexible conduit shall be used for connections to motors and other equipment subject to vibration and shall be waterproof.

7.1.2 Conduit Installation, General Requirements: Conduit shall be installed exposed in walls, floors and ceilings. Maintain a minimum distance of 6 inches from parallel runs of water pipes. For floor mounted equipment, conduit may be run overhead and dropped down, where underfloor installation is not practicable. Groups of conduit shall be uniformly spaced, where straight and at turns. Bends and offsets, where unavoidable, shall be made with hickey or bending machine. Conduit shall be cut with a hacksaw or an approved conduit-cutting machine and reamed after threading to remove all burrs. Securely fasten conduit to outlets, junction and pull boxes to effect firm electrical contact. Join conduit with approved couplings. Expansion fittings shall be installed in conduit where it passes through structural expansion joints. Trapped conduits shall be avoided. Plaster, dirt or trash shall be prevented from lodging in conduits, boxes, fittings and equipment during construction. Clogged conduits shall be freed of all obstructions.

7.1.3 Conduit Support: Conduit shall be supported every 8 feet and shall be installed parallel with or perpendicular to walls, structural members or intersections of vertical planes and ceilings with right angle turns consisting of fittings or symmetrical bends. Conduits shall be supported within 1 foot of all changes in direction. Supports shall be approved pipe straps, wall brackets, hangers or ceiling trapeze. Fastenings shall be by wood screws to wood; by toggle bolts on hollow masonry units; by expansion bolts on concrete or brick; by machine screws, welded threaded studs, or spring-tension clamps on steel work. Explosive-drive equipment may be used to make connections where the use of this equipment complies with safety regulations. Wooden plugs inserted in masonry and the use of nails as fastening media are prohibited. Threaded C-clamps may be used on rigid steel conduit only. Conduits or pipe straps shall not be welded to steel structures. The load applied to fasteners shall not exceed 1/4 of the proof test load. Fasteners attached to concrete ceiling shall be vibration and shock resistant. Holes cut to a depth of more than 1-1/2 inches in reinforced concrete beams or to a depth of more than 3/4 inch in concrete joints shall not cut the main reinforcing bars. Holes not used shall be filled. In partitions of light steel construction, sheet-metal screws shall be used. Spring steel fasteners may only be used to support lighting branch circuit conduits to structural steel members. Conduits shall be fastened to all sheet-metal boxes and cabinets with two locknuts where required by the National Electrical Code, where insulated bushings are used and where bushings cannot be brought into firm contact with the box. Locknuts shall be the type with sharp edges for digging into the wall of metal enclosures. Bushings shall be installed on the ends of all conduits and shall be of the insulating type where required by the National Electrical Code.

7.1.4 Conduit installed in concrete floor slabs shall be located so as not to affect the structural strength of the slabs. Conduit shall be installed within the middle one-third of the concrete slab except where necessary to not disturb the reinforcement. Outside diameter of conduit shall not exceed one-third of the concrete slab except where necessary to keep from disturbing the reinforcement. Outside diameter of conduit shall not exceed one-third of the slab thickness and conduits shall be spaced not closer than three diameters except at cabinet locations. Curved portions of bends shall not be visible above the finish slab. Slab thickness shall be increased as necessary to provide a minimum one inch cover over conduit. Where embedded conduits cross expansion joints, suitable watertight expansion fittings and bonding jumpers shall be provided. Conduit larger than one inch trade size shall be parallel with or at right angles to the main reinforcement; when at right angles to the reinforcement, the conduit shall be close to one of the supports of the slab. Conduits shall not be stacked more than 2 diameters high in floor slabs.

7.1.5 Wireway: Wireway shall be installed where required by NEC and as indicated.

7.2 Boxes and Outlets: Boxes shall be provided in the wiring or raceway systems wherever required for pulling of wires, making connections, and mounting of devices or fixtures. Boxes shall be furnished with screw-fastened covers. Where several feeders pass through a common pull box, the feeders shall be tagged to indicate clearly the electrical characteristics, circuit number, and panel designation. Gaskets shall be provided on boxes and outlets where required to insure watertight installation.

7.2.1 Stub-Ups: Conduits stubbed up through concrete floors for connections to free-standing equipment shall be provided as indicated. Wiring shall be extended in rigid threaded conduit to equipment, except that where required, flexible conduit may be used 6 inches above the floor. Screwdriver-operated threaded flush plugs shall be installed in conduits from which no equipment connections are made.

7.3 Receptacle Mounting: Receptacles shall be mounted 18 inches above finished floor unless indicated otherwise.

7.4 Toggle Switches: Switches shall be installed as indicated and shall be located 4 feet 6 inches above finished floor levels and be connected so as to afford control over the indicated outlets and shall be waterproof.

7.5 Wiring - General: Suitable equipment shall be used to pull conductors through conduit, exercising due care to avoid damage to insulation. Wires shall not be pulled through conduits before the conduit system is complete and has been carefully freed from obstruction of any kind. Soapstone or an approved compound may be employed to facilitate pulling wires. Where two or more circuits are housed in one conduit, a common neutral may be used if sized in compliance with NEC. Wires and cables shall be installed in conduit.

7.7 Splices and Terminations: Splices and terminations shall be made in outlet or junction boxes and shall be mechanically and electrically secure, using proper thickness of tape. Mechanical connectors of every kind shall be taped. Splices and terminations shall be covered with an insulation material equivalent to the conductor insulation. Connections involving aluminum conductors shall utilize approved type fittings and joint compound. Flashover or insulation value of joints shall be at least 100% in excess of wire insulation. Terminal strips shall be used for interconnecting or splicing control cables, communication cables and other conductors where called for on the drawings. These terminal strips shall be of the proper voltage, properly labeled and mounted in a cabinet.

7.8 Panelboards: Panelboards shall be located as indicated and shall be so mounted that the height of the top operating handle will not exceed 6 feet 6 inches from the floor.

7.9 Disconnect Switches: Disconnect switches shall be provided where indicated.

7.10 Fuses: Fuses shall be provided in ratings indicated.

7.11 Motors and Controllers: Motors and controllers furnished under the division entitled "Mechanical" shall be installed under this section. Motors and controllers shall be mounted and wired to operate as indicated.

7.12 Grounding and Bonding: Except where specifically indicated otherwise, all exposed non-current-carrying metallic parts of electrical equipment, metallic raceway systems, and neutral conductor of wiring systems shall be grounded. The ground connection shall be made at the main service equipment and shall be extended to the point of entrance of

the metallic water service. Connection to the water pipe shall be made by a suitable ground clamp or lug connection to a plugged tee. If flanged pipes are encountered, connection shall be made with the lug bolted to the street side of the flanged connection. If there is no metallic water service to the building, ground connection shall be made to driven ground rods on the exterior of the building. Where ground fault protection is employed, care shall be taken so that the connection of ground and neutral does not interfere with the correct operation of the fault protection.

7.12.1 Equipment Grounds: Equipment grounds shall be solid and continuous from a connection at earth to all distribution panelboards. Ground connections at panelboards, outlets, equipment and apparatus shall be made in an approved and permanent manner.

7.12.2 Resistance: The maximum resistance to ground of a driven ground rod shall not exceed 25 ohms under normally dry conditions. Where the resistance obtained with one ground rod exceeds 25 ohms, additional ground rods shall be installed not less than 6 feet on centers.

7.13 Equipment Connections: All power wiring for the connection of motors and control equipment as indicated on the electrical drawings shall be provided under this section of the specification.

7.14 Concrete: All concrete work shall be in accordance with the applicable requirements of Section entitled "Cast-In-Place Concrete".

7.15 Field Painting: Metal surfaces, excluding aluminum and zinc-coated or factory prefinished surfaces, shall receive one coat of pretreatment coating conforming to specification MIL-P-15328 applied to a dry film thickness of 0.3 to 0.5 mil and one coat of zinc-chromate primer conforming to specification TT-P-645 applied to a minimum dry film thickness of 1.0 mil. After receiving the coatings specified hereinbefore, metal surfaces shall receive two coats of paint conforming to specification TT-E-489 applied to a minimum dry film thickness of 1.0 mil each coat.

8. FIELD TESTS: The Contractor shall perform all field tests and shall provide all labor, equipment and incidentals required for testing, except that the Government will provide electric power required for the tests. All defective material and workmanship disclosed shall be corrected by the Contractor at no cost to the Government. The Contractor shall show by demonstration in service that all circuits and devices are in good operating condition. Tests shall be such that each item of control equipment will function not less than five times.

8.1 Insulation resistance test for systems 600 volts and less. After all wiring is completed and connected ready for operation, but prior to placing systems in service and before any branch circuit breakers are closed, insulation resistance tests shall be made in all feeder and subfeeder circuits. The insulation resistance between conductors and between such conductor and ground shall be measured. Measurements shall be made with an instrument capable of making measurements at an applied potential of 500 volts. Readings shall be taken after the voltage has been applied for a minimum of one minute. The minimum insulation resistance for circuits of No. 12 AWG conductors shall be 1,000,000 ohms. For circuits of No. 10 AWG or larger conductors, a resistance based on the allowable ampacity of the conductor shall be as follows:

25 through 50 amperes	250,000 ohms
51 through 100 amperes	100,000 ohms

8.2 Grounding system shall be tested to assure continuity and compliance with the requirement that ground resistances not exceed 25 ohms. Ground resistance measurements of each ground rod shall be taken and certified by the Contractor. Upon completion of the project, the Contractor shall submit to the Contracting Officer, the measured ground resistance of each ground rod and grounding system, indicating the location of the rod and grounding system, as well as the resistance and soil conditions at the time the measurements were made. Ground resistance measurements shall be made in normally dry weather, not less than 48 hours after rainfall, and with the ground under test isolated from other grounds. Ground resistance shall also be measured from each piece of equipment to the ground electrode and shall not exceed three (3) ohms.

---o0o---

NOTE:

FIXTURE SCHEDULE INDICATES
TYPE OF MOUNTING.

3/4" RIGID STEEL CONDUIT
FIXTURE STEM

VENTILATED NECK

DETACHABLE PORCELAIN ENAMELED
STEEL REFLECTOR

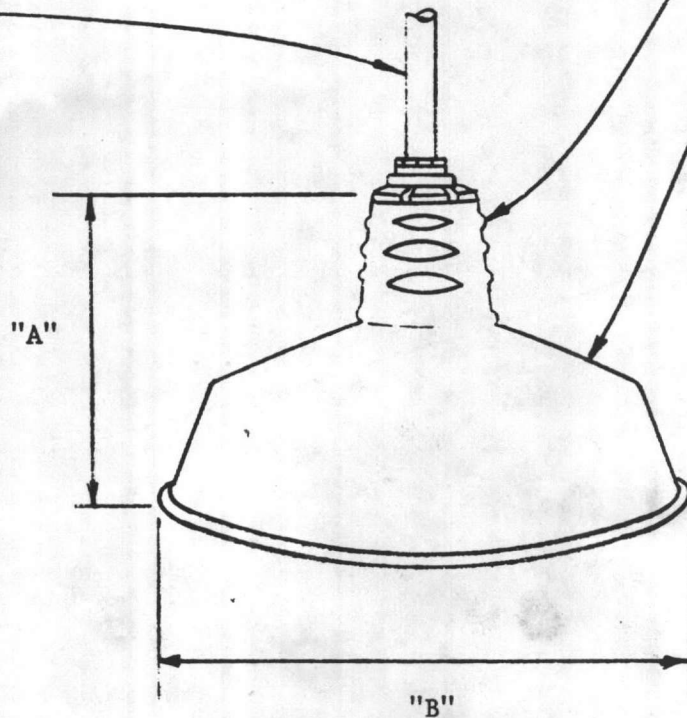

FIXTURE TYPE	LAMPS	DIMENSIONS	
		"A"	"B"
16-I-1	1-150W	9"	14"
16-I-2	1-200W	10"	16"
16-I-3	1-300W	12"	18"

TYPE 1 THRU 3

LANTDIV PLATE 16-I

6-76

05-76-6799
16402 - 15

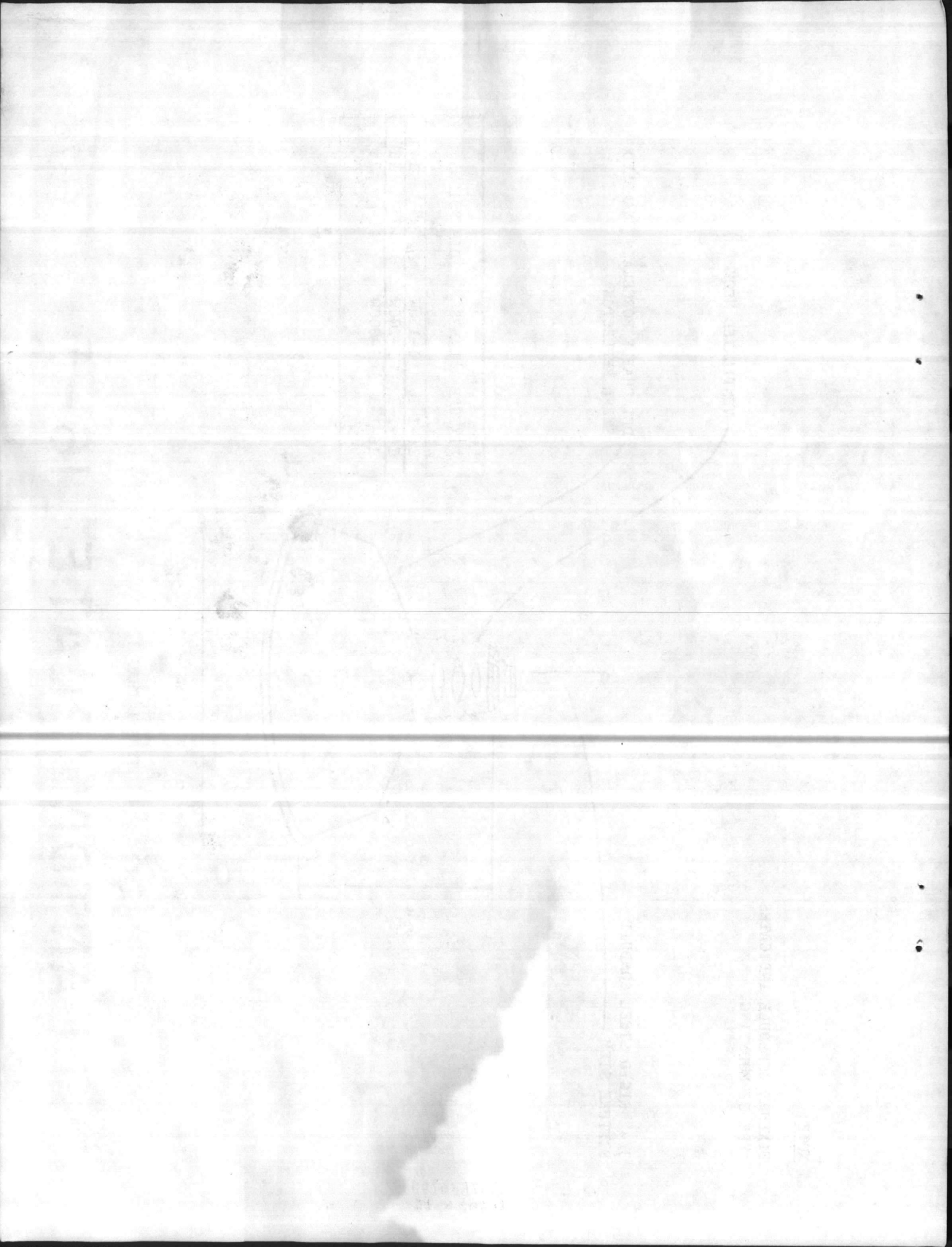

SUPERSEDEAS DECISION

STATE: North Carolina
 DECISION NO.: NC75-1078

COUNTIES: Statewide
 DATE: Date of Publication

SUPERSEDEAS DECISION: NC75-1002 dated January 17, 1975 in 40 FR 3149
 DESCRIPTION OF WORK: Water & Sewer Construction; and Heavy Construction

	BASIC	FRINGE BENEFITS PAYMENTS			
	HOURLY RATES	H & W	PENSIONS	VACATION	APP. TR.
Bricklayers	\$4.44				
Carpenters	4.30				
Cement Masons	4.16				
Ironworkers:					
Reinforcing	3.38				
Structural	4.00				
Laborers:					
Asphalt Rakers	3.30				
Laborers	2.78				
Pipelayers	3.38				
Powderman	4.35				
Manhole Builders	3.73				
Millwrights	4.05				
Painters	3.00				
Piledrivers	4.25				
Pipefitters	4.10				
<u>POWER EQUIPMENT OPERATORS:</u>					
Air Drill Operators	3.88				
Asphalt Distributors	3.14				
Backhoe	4.05				
Bulldozers	3.89				
Crane & Dragline	4.40				
Equipment Mechanics	4.12				
Front End Loader	3.73				
Gradall	3.95				
Motor Grader	4.08				
Oiler	3.50				
Pan Operator	3.30				
Paving Form Setter	4.00				
Paving Machines, Asphalt	3.60				
Rollers	2.78				
Screed, Asphalt	3.50				
Tractor	2.78				
Trenching Machines	3.68				
Truck Drivers	2.79				
Welders	4.50				

FEDERAL REGISTER, VOL. 40, NO. 173 - - - FRIDAY, SEPT. 5, 1975

