

## VERTICAL TURBINE PUMPS SINGLE STAGE PERFORMANCE

**3000  
RPM**

**1770  
RPM**

ENCLOSED  
IMPELLER  
T7DA92

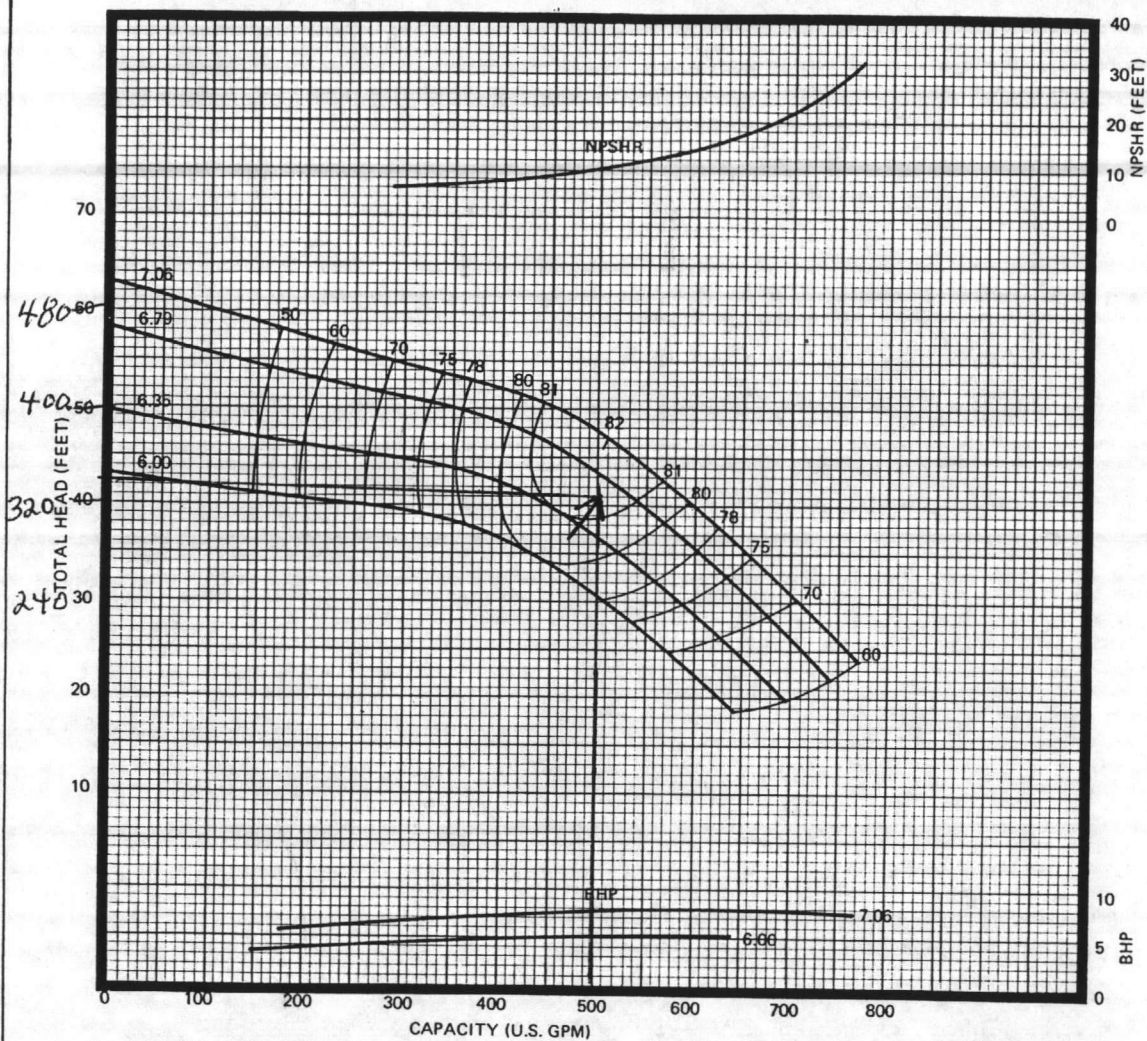

### EFFICIENCY CORRECTIONS<sup>(1)</sup>

NUMBER OF STAGES	EFFICIENCY CHANGE
1	-3.0 POINTS
2	-2.0 POINTS
3	-1.0 POINTS
4	NO CHANGE
5	NO CHANGE
6 OR MORE	NO CHANGE

BOWL MATERIAL	EFFICIENCY CHANGE
CAST IRON	-2.5 POINTS
ENAMELED C.I.	NO CHANGE

IMPELLER MATERIAL	EFFICIENCY CHANGE
CAST IRON	-1.0 POINTS
BRONZE	NO CHANGE
ENAMELED C.I.	NO CHANGE

(1) Refer to "Application and Reference Data" for head correction.

### DIMENSIONS (Inches)

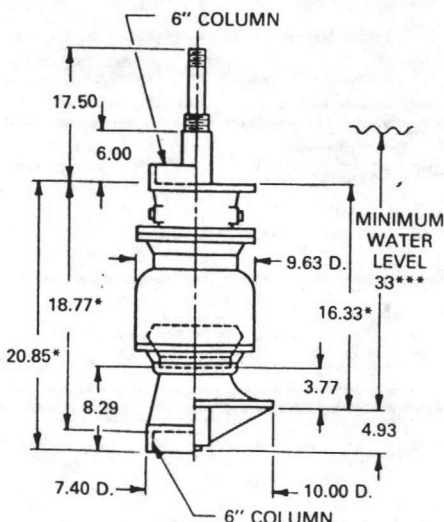

\*Add 8.25 for each additional stage

### TECHNICAL DATA

DATA	VALUE
MAXIMUM OPERATING SPEED	3000 RPM
MAXIMUM NUMBER OF STAGES	18**
PUMP SHAFT DIAMETER	1 1/16 IN.
IMPELLER EYE AREA	11.19 SQ. IN.
MAXIMUM SPHERE SIZE	.68 IN.
K <sub>t</sub> (THRUST FACTOR)	3.80 LBS./FT.
K <sub>a</sub> (ROTOR WT. PER STAGE)	15.75 LBS.
BOWL WT. (FIRST STAGE)	180 LBS.
BOWL WT. (EACH ADD'L. STAGE)	49 LBS.
ALLOWABLE SHAFT STRETCH	.63 IN.**
WK <sup>2</sup> (FIRST STAGE)	.52 LBS.-FT. <sup>2</sup>
WK <sup>2</sup> (EACH ADD'L. STAGE)	.50 LBS.-FT. <sup>2</sup>
BOWL RING CLEARANCE	.014/.018 IN.

\*\* These are nominal values. Refer to "Application and Reference Data" for information further limiting or extending these values.

\*\*\* This value is the minimum submergence required to prevent vortexing only. This value may need to be increased to provide adequate NPSHA.

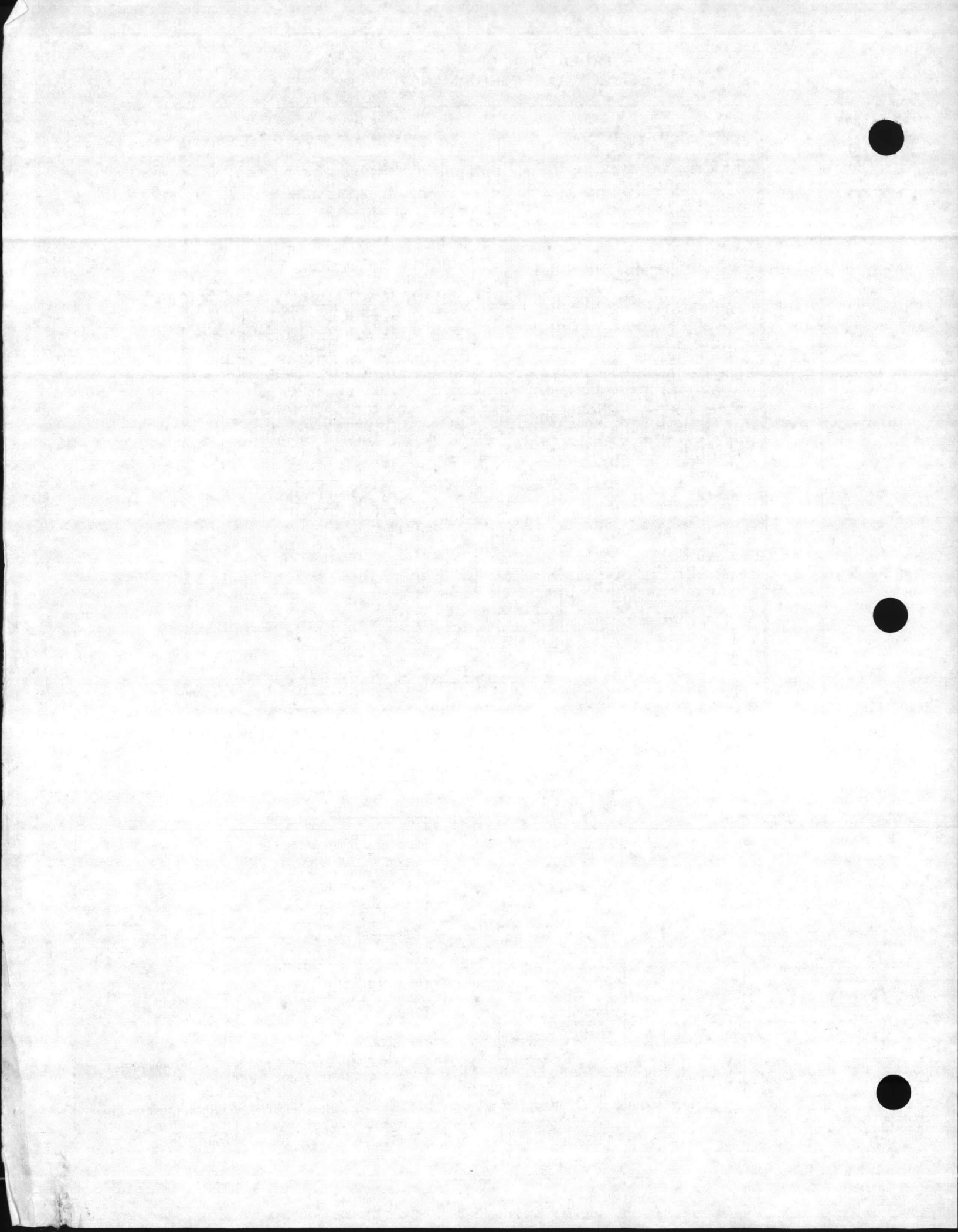

**DEFINITIONS AND TERMINOLOGY**

**DATUM** is the horizontal plane defined by the elevation of the bottom of the discharge head. Sometimes the centerline of the discharge is referred to as the datum, but then the vertical distance in feet between the centerline of discharge and the bottom of the discharge head should be accounted for.

**SETTING** is the distance in feet from the column connection datum at the discharge head to the column connection at the bowl assembly.

**STATIC LEVEL** is the distance, in feet, between the datum and the liquid level when the pump is not operating.

**PUMPING LEVEL** is the distance, in feet, between the datum and the liquid level when the pump is operating.

**DRAWDOWN** is the difference, in feet, between the static level and the pumping level.

**CAPACITY** is the rate of flow, usually expressed as gallons per minute (GPM).

**STATIC DISCHARGE HEAD** is the vertical distance in feet the liquid must be raised above the datum.

**LIFT (HEAD) BELOW DATUM** is the vertical distance, in feet, between the datum and the pumping water level.

**VELOCITY HEAD** is the kinetic energy of the liquid in feet of head per unit weight.

**HEAD ABOVE DATUM** is the static discharge head plus the friction loss through the discharge line and fittings plus the velocity head.

**PUMP TOTAL HEAD** is equal to the lift below datum plus head above datum. This is the head for which the customer is responsible and is exclusive of any pump losses.

**COLUMN FRICTION LOSS** is the friction loss, in feet of head, through the column and is dependent upon both capacity and the length and diameter of column and shaft used. Column friction loss is determined from a **COLUMN FRICTION LOSS CHART** and is indicated in feet of head per hundred feet of column and shaft. (See pages 39-42).

**DISCHARGE HEAD FRICTION LOSS** can be determined from the **DISCHARGE ELBOW FRICTION LOSS CHART** on pages 43-45. These losses are usually very small and can be ignored.

**BOWL TOTAL HEAD (OR LABORATORY HEAD)** is the head, in feet, on the pump bowl and is equal to the pump total head plus the column friction loss and the discharge elbow loss. (Shown as total head on performance curves)

$$\text{BOWL TOTAL HEAD} = \text{PUMP TOTAL HEAD} + \text{COLUMN FRICTION LOSS} + \text{DISCHARGE ELBOW LOSS}$$

**BOWL EFFICIENCY (OR LABORATORY EFFICIENCY)** is the efficiency as indicated on the bowl performance curve, including any applicable corrections.

**SPECIFIC GRAVITY** is a relative term which expresses the fluid's density with reference to fresh water at 39.2 degrees F. Specific gravity of water is 1.0.

$$\text{SPECIFIC GRAVITY} = \frac{\text{DENSITY OF FLUID PUMPED (LBS./FT.}^3\text{)}}{\text{DENSITY OF WATER (LBS./FT.}^3\text{)}}$$

**BOWL HORSEPOWER (OR LABORATORY HORSEPOWER)** is the horsepower required at the bowl shaft to deliver the required capacity against the bowl total head and is defined by the following formula:

$$\text{BOWL HORSEPOWER} = \frac{\text{BOWL TOTAL HEAD (FEET)} \times \text{CAPACITY (GPM)} \times \text{SPECIFIC GRAVITY}}{3960 \times \text{BOWL EFFICIENCY}}$$

**SHAFT LOSS** is the friction loss, measured in horsepower, between the shaft and its bearings. Line shaft loss is determined from the **LINE SHAFT LOSS CHART** and is indicated in horsepower per hundred feet of shafting. (See page 43).

**BRAKE HORSEPOWER (OR FIELD HORSEPOWER)** is the horsepower required at the top shaft and is equal to the bowl horsepower plus shaft loss.

$$\text{BRAKE HORSEPOWER} = \text{BOWL HORSEPOWER} + \text{SHAFT LOSS}$$

**PUMP FIELD EFFICIENCY** is the efficiency of the complete pump with all losses accounted for.

$$\text{PUMP FIELD EFFICIENCY} = \frac{\text{PUMP TOTAL HEAD (FT)} \times \text{CAPACITY (GPM)} \times \text{SPECIFIC GRAVITY}}{3960 \times \text{BRAKE HORSEPOWER}}$$

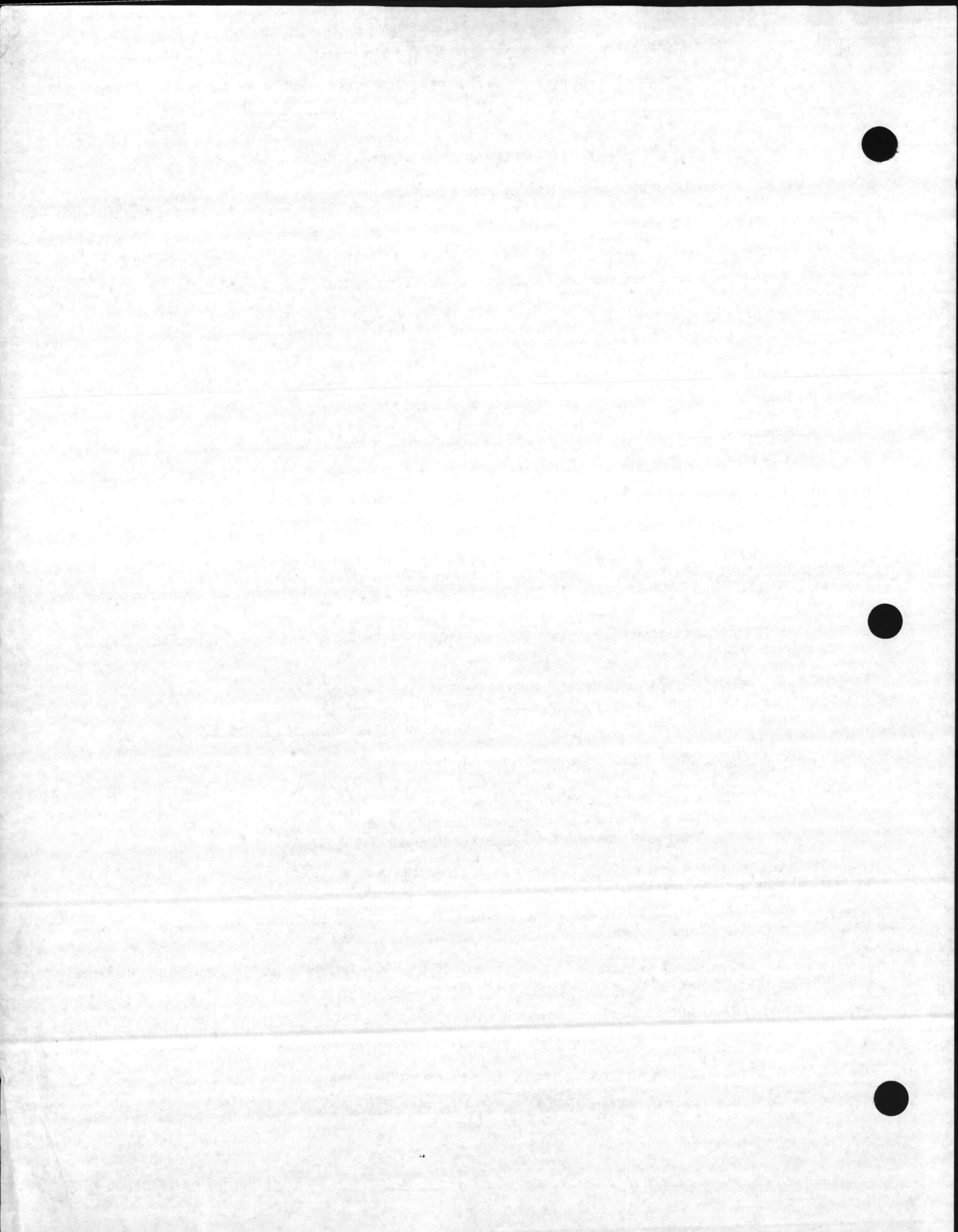

VISCOSITY of a liquid is a measure of the internal friction tending to resist flow. The performance of vertical turbine pumps is affected when handling viscous liquids. The exact affect on performance when handling viscous liquids can be determined from the information published in the Fairbanks Morse Hydraulic Handbook or in the Hydraulic Institute Engineering Data Book.

TOTAL PUMP THRUST is composed of the weight of the rotating parts in the pump bowls, the weight of the line shaft, and the hydraulic thrust of the liquid being pumped. Total pump thrust equals the summation of:

$K_t \times \text{BOWL HEAD}$ :  
WHERE ( $K_t$ ) IS THE HYDRAULIC THRUST CONSTANT.

$K_a \times \text{NUMBER OF STAGES}$ ;  
WHERE ( $K_a$ ) IS ROTOR WEIGHT PER STAGE.

$K_s \times \text{LENGTH OF LINE SHAFT}$ ;  
WHERE ( $K_s$ ) IS WEIGHT PER FOOT OF LINE SHAFT.

THRUST BEARING LOSS is the friction loss, in horsepower, developed by the total thrust load on the bearing. Bearing manufacturers estimate the loss in angular contact bearings to be approximately 0.0075 HP per 100 RPM per 1000 Lbs. Thrust Load. It can also be determined using a THRUST BEARING CHART, available from the Motor Manufacturer.

DRIVER EFFICIENCY is the ratio of driver output to driver input with no external thrust load and therefore must be adjusted to reflect thrust bearing loss.

$$\text{DRIVER EFFICIENCY} = \frac{\text{DRIVER OUTPUT (NAMEPLATE RATING)}}{\text{DRIVER INPUT} + \text{THRUST BEARING LOSS}}$$

OVERALL EFFICIENCY (WIRE TO WATER EFFICIENCY) is the efficiency of the pump and motor complete.

$$\text{OVERALL EFFICIENCY} = \text{PUMP FIELD EFFICIENCY} \times \text{DRIVER EFFICIENCY}$$

DRIVER INPUT HORSEPOWER is the total power required to operate the pump and motor and a measure of the amount of power that must be supplied by the user.

$$\text{INPUT HP} = \text{Output HP (Nameplate)} / \text{Driver EFF (No Load Rating)}$$

NPSH (NET POSITIVE SUCTION HEAD) can be defined as the head, in feet, at the eye of the impeller that causes the liquid to flow. Available NPSH in open systems is the summation of the barometric pressure plus the distance from the static liquid level to the impeller eye minus the vapor pressure of the pumped liquid. Available NPSH in closed systems is the summation of the gage pressure, in feet, at the suction flange plus the vertical distance in feet, to the impeller eye\* minus friction losses between the gage connection and the impeller eye.

\*If the suction flange is below the impeller eye, subtract this distance from the gage pressure.

For additional discussion of NPSH refer to the Fairbanks Morse Hydraulic Handbook.

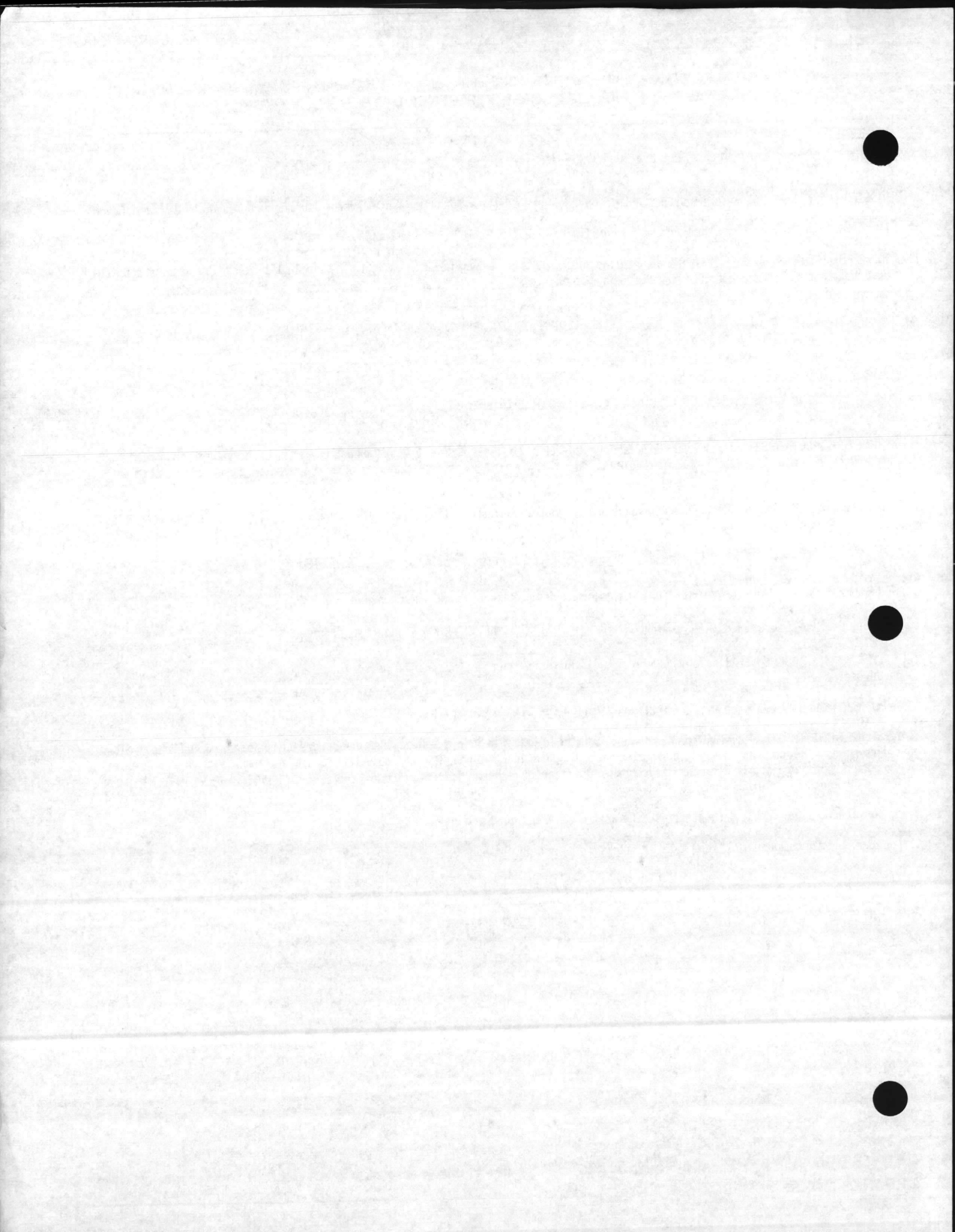

**PURPOSE**

The purpose of the Application and Reference Data Section is to provide a section that, hopefully, the most inexperienced person, with careful reading and study, can select and apply a vertical pump given a set of parameters with which to work. This section contains a list of commonly used terminology and definitions, what information is required to select and apply a pump, an example of pump selection, modifications required for items not covered in the example, and the necessary charts and graphs which are referred to in the text of this section.

**PUMP SELECTION (GENERAL)**

The following is an example of pump selection. The statement on the left is the user requirement, and immediately following in ( ) is the data regarding the application that must be known and would normally be supplied by the user.

**USER REQUIREMENTS**

- |  |                            |
|--|----------------------------|
| 1. Quantity required:  | (2)                        |
| 2. Delivery requirement:   | (Within 6 weeks)           |
| 3. Driver Type: e.g. motor, gear, belt, speed  | (Electric motor, 1770 RPM) |
| 4. Type of power available   | (Electric)                 |
| A. Electrical  | (3/60/460V,)               |
| 1. Phase, frequency, voltage.  |                            |
| B. Mechanical  |                            |
| 1. Engine type, fuel, clutch requirements, accessories, etc.   | (None)                     |
| 5. Line shaft lubrication: (oil, product)  |                            |
| A. Oil   | (Oil lubrication)          |
| B. Product e.g. water, fuel, etc.  |                            |
| 6. Type of discharge:  |                            |
| A. Above ground  | ( above ground)            |
| B. Below ground  |                            |
| 1. Location of centerline of discharge with respect to the bottom of the motor pedestal is required. | (N/A)                      |
| 7. Pump setting  |                            |
| A. Total length of column and wall thickness   | (400 Ft., 0.250 wall)      |
| 8. Length of suction pipe, if any  | (2 1/2 Feet)               |

**PUMP OPERATING CONDITIONS**

- |  |             |
|--|-------------|
| 9. Design capacity in GPM  | (750 GPM)   |
| 10. Datum elevation in feet  | (Sea level) |
| 11. Pumping water level at design capacity in feet below datum                   | (400 feet)  |
| 12. Head above datum, including losses through discharge line plus velocity head | (246)       |
| 13. Pump total head at design capacity   |             |
| A. Lines 9 plus 10   | (646)       |
| 14. Operating range, if any  | (None)      |
| A. Minimum pump total head   |             |
| B. Maximum pump total head   |             |
| 15. Any other operating conditions of note                                       | (None)      |

**WELL CONDITIONS**

- |   |           |
|---|-----------|
| 16. Minimum inside diameter of well   | (12")     |
| 17. Maximum outside diameter of bowl  | (11 5/8") |
| 18. Total depth of well or sump   | (500 ft.) |
| 19. Is well straight to pump setting depth? Note: A well is considered straight if a 20 ft. cylinder equal to the maximum diameter of the bowl will not bind when lowered to a depth equal to the pump setting. | (Yes)     |
| 20. Static water level below datum, in feet   | (350 ft.) |
| 21. Sand in water   | (No)      |
| 22. Gas in water, parts per million   | (None)    |
| 23. Other unusual conditions  | (None)    |

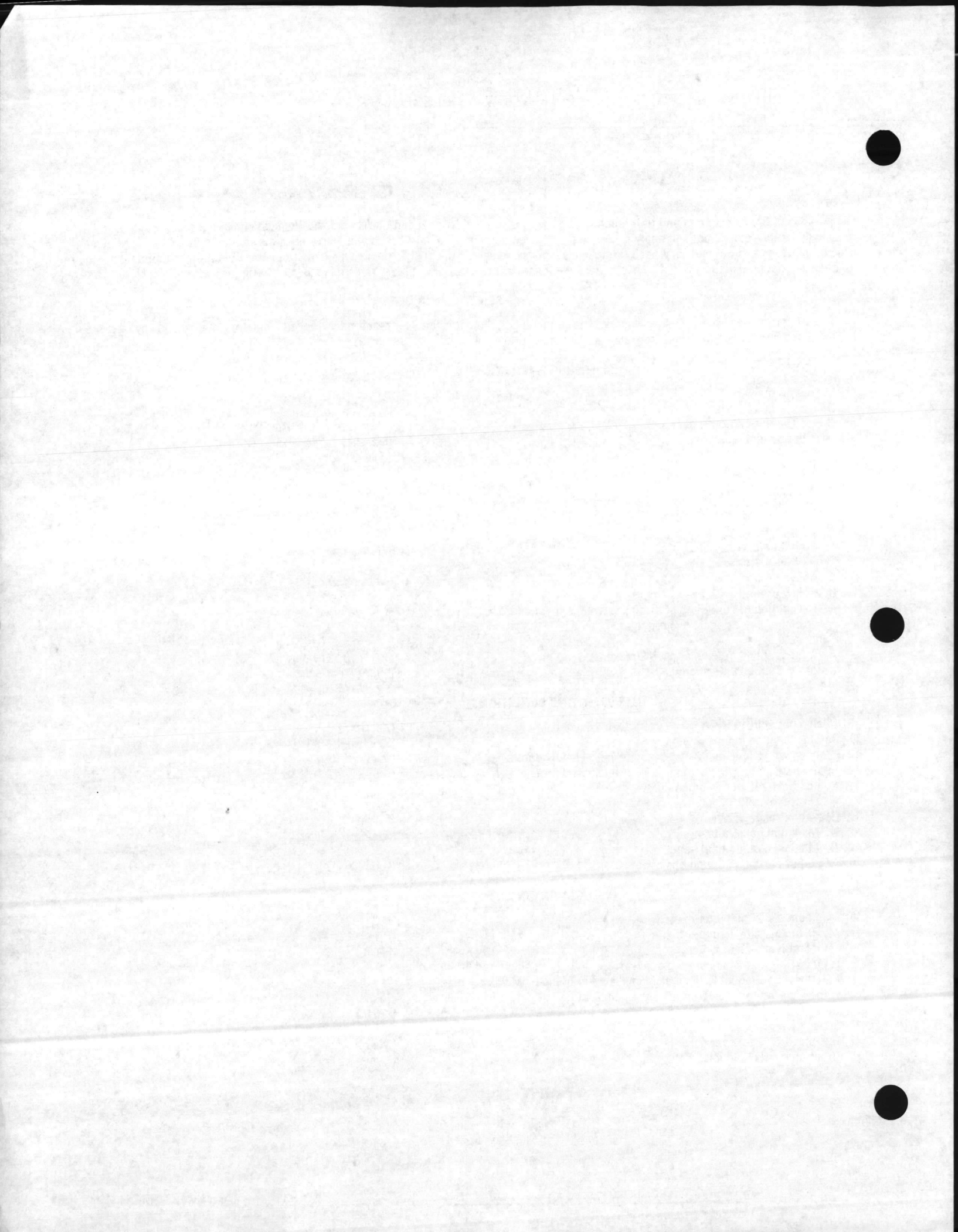



**ACCESSORY REQUIREMENTS**

- 24. Companion flange required? (Yes)
- 25. Discharge stub required? (Yes)
- 26. Strainer required? Type? Material? (Yes, Cone, Galvanized)
- 27. Lubricator required? Type? (Yes, one gal., manual)
- 28. Automatic controls required? Type: (No)
  - A. Lubricator
  - B. Time delay
  - C. Float switch
- 29. Prelube water tank required? Capacity? (No)
- 30. Airline and gauge required? (Yes)
- 31. Motor accessories required?
  - A. Space heaters, specify voltage (No)
  - B. Non-reverse ratchet (Yes)
  - C. Bearing and winding temperature detectors (No)
  - D. Extra high thrust (To be determined)
  - E. Special insulation (No)
  - F. Other (None)

**PUMP SELECTION (SPECIFIC)**

Having established the parameters for the given installation, we can now proceed to specific pump selection and evaluation. In most cases there are four major components that must be selected and evaluated. These are: bowl assembly, column and shaft, discharge head and packing box, and driver. A step by step approach for selection and evaluation of each follows:

**BOWL ASSEMBLY**

Having established the design capacity, pump total head, speed and maximum permissible bowl outside diameter, the initial step in bowl selection is to determine which bowls supply the required capacity. To do this, refer to the performance coverage charts in this catalog. Select the coverage chart for the speed desired and note all of the bowls that can produce the desired capacity.

Example: It has been established above that this application requires:

- Capacity: 750 GPM
- Pump total head: 646 feet
- Speed: 1770 RPM
- Maximum bowl outside diameter: 11<sup>5</sup>/<sub>8</sub>"

With this data, refer to the 1800 RPM coverage chart in this catalog and list all bowls capable of producing 750 GPM. This would include the 10XH, 11M, 11H, 12L, 12M, 12H, and 14M. Now begin the process of elimination to find the best selection. At this point the obviously inappropriate bowls can be eliminated for the following reasons:

A. The bowl will not physically fit into the well casing. To determine this, refer to the bowl dimensions shown on the bowl performance curve. If the outside diameter of the bowl is larger than the inside diameter of the well (or the maximum permissible outside diameter), eliminate the bowl from further consideration.

Example: The 12M (12.26" O.D.) and the 14M (14.1" O.D.) must be eliminated.

B. The bowl pressure capability is less than the required bowl head. Since column friction loss and discharge elbow loss have not yet been established, add 5 feet for every 100 feet of column to the pump total head to establish a tentative bowl total head. (Discharge elbow loss is usually small and will be ignored at this point.)

Example: Tentative Bowl Head = 646 Feet +  $\left(\frac{5 \text{ Feet}}{100 \text{ Feet}} \times 400 \text{ feet}\right) = 666 \text{ Feet}$

After tentative bowl head is established, eliminate all bowls that cannot meet this requirement. Refer to the BOWL PRESSURE RATING CHART on page 22.

Example:

BOWL	MAX PRESSURE IN FEET
10XH	661 PSI × 2.31 FT/PSI = 1527
11M	488 PSI × 2.31 FT/PSI = 1127
11H	488 PSI × 2.31 FT/PSI = 1127
12L	415 PSI × 2.31 FT/PSI = 958
12H	456 PSI × 2.31 FT/PSI = 1053

Since the tentative bowl head is 666 feet, all of the bowls can produce the required tentative bowl total head.

Example: The bowl cannot be staged to meet the required head.

At this point, you can either refer to the TECHNICAL DATA shown on the bowl performance curve to find the nominal maximum number of stages for that bowl or, for a more precise analysis, proceed as indicated below.

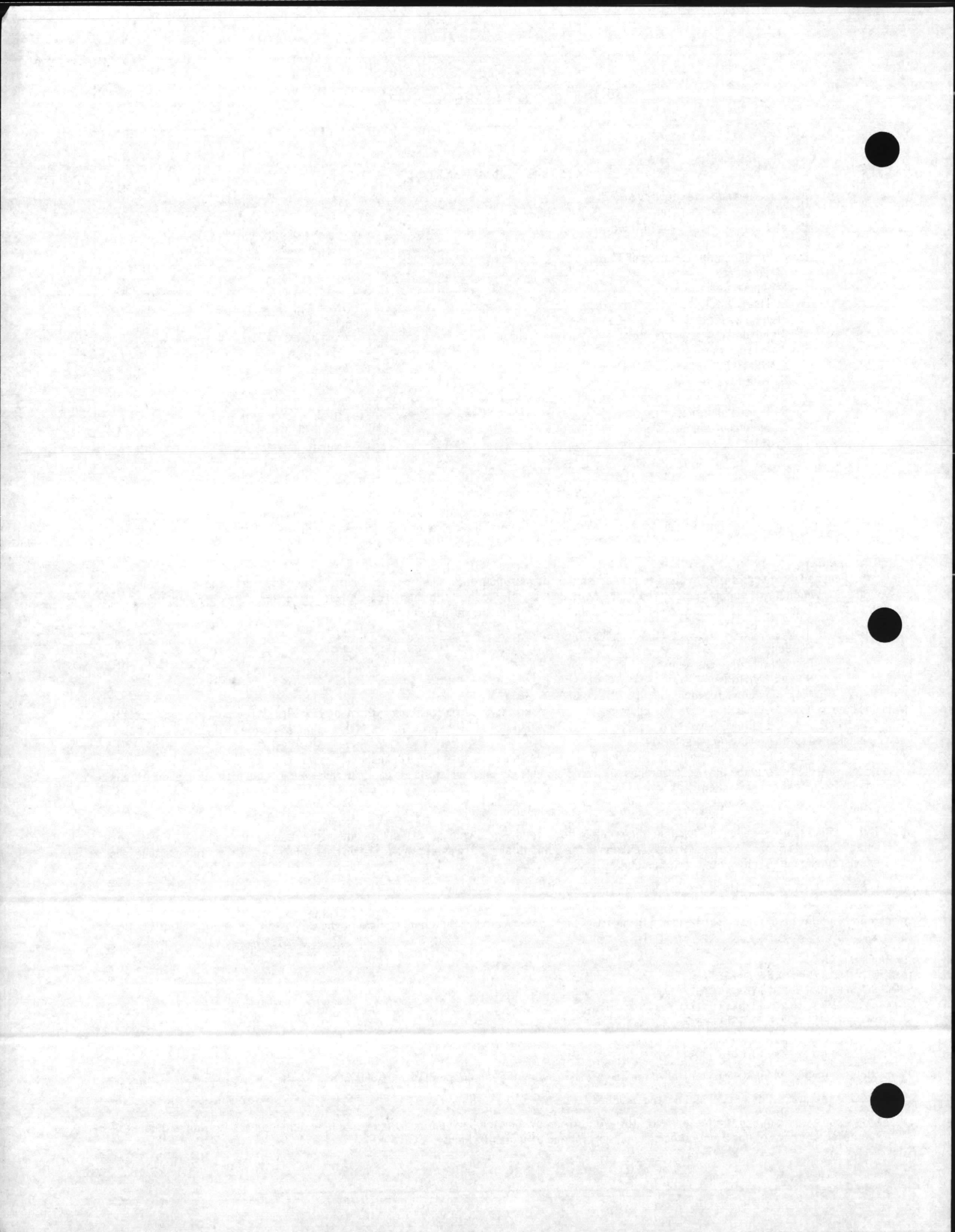

The MAXIMUM NUMBER OF STAGES data shown on the bowl performance curve is footnoted to indicate that the values are nominal. The reason for this is that the limitation on staging is a function of the pressure capability of the bowl, the horsepower and thrust rating of the bowl shaft, and the length of the bowl shaft. The nominal value shown on the performance curve is based upon what is generally considered to be the USEFUL PORTION of the head-capacity curve. Based on the specific job a higher number of stages may be possible.

Establish the number of stages required to produce the tentative bowl total head by first referring to the bowl performance curve to determine head per stage at design capacity. Then divide tentative bowl total head by head per stage to determine staging. Round off any fractions to the next higher whole number.

Example:

BOWL	HEAD PER STG @ 750 GPM	CALCULATION	NO. OF STAGES REQUIRED
10XH	44	666/44 = 15.14	16
11M	61	666/61 = 10.92	11
11H	59	666/59 = 11.29	12
12L	83.5	666/83.5 = 7.98	8
12H (T9EA99A)	72	666/72 = 9.25	10

Now determine whether or not the bowl shaft will carry the estimated bowl horsepower and thrust. To do this, list for each bowl the bowl efficiency, and thrust constants  $K_t$  and  $K_a$ . This information can be found on the bowl performance curve. In determining bowl efficiency be sure to account for any corrections due to staging or special materials. Staging corrections are shown on the performance curve and material correction factors are shown on page 22 EFFICIENCY CORRECTION CHART for special materials. Calculate the estimated bowl horsepower using the following formula:

$$\text{Estimated bowl horsepower} = \frac{\text{Tentative Bowl Head (feet)} \times \text{Capacity (GPM)} \times \text{Specific Gravity}}{3960 \times \text{Bowl Efficiency}}$$

Calculate the thrust imposed on the bowl shaft by the formula: thrust = ( $K_t \times$  Tentative Bowl Head) + ( $K_a \times$  Number of stages)

Example: 10XH = (8.32 x 666) + (10 x 16) = 5701 lbs.

To determine the maximum allowable horsepower and thrust rating of the bowl shaft, refer to the BOWL SHAFT RATING CHART on pages 23-25

Example:

BOWL	STAGES	EFFICIENCY	EST. HP	$K_t$	$K_a$	THRUST (LBS.)
10XH	16	72.5%	174	8.32	10	5701
11M	11	82.5	153	5.02	22	3585
11H	12	67.0	188	8.71	33	6197
12L	8	80.0	158	6.06	26	4244
12H	10	71.0	180	8.44	16.1	5782

As a result of this analysis, we find all of the bowl shafts are within the horsepower and thrust limitations.

At this point it may be possible to narrow the bowl selection process by comparing efficiencies and initial costs of the remaining bowls. Bowl efficiencies have already been established to calculate bowl horsepower.

The cost per bowl can be obtained from the price pages. Now rank the bowls from the lowest to highest cost showing staging and efficiency. Eliminate all bowls that are both high in cost and low in efficiency.

Example:

BOWL	COST	STAGES	EFFICIENCY
12L	Lowest	8	80.0%
12H		10	70.0
11M		11	82.5
11H		12	67.0
10XH	Highest	16	72.5

From this comparison, the 10XH and the 11H can be eliminated from further consideration as they have the highest cost.

If the pump setting is less than 50 feet, then relative shaft stretch (discussed later in this text) is not a factor and the remaining bowls can be analyzed to determine the best overall selection.

### COLUMN SELECTION

The discharge case of the bowl assembly is sized to accommodate the capacity produced by the bowl at its best efficiency point with minimal friction loss. Therefore, column size is normally selected as a function of the discharge case connection size.

In some cases, deep settings would cause the total column friction loss to be significant and a larger size column may be appropriate. The cost of the larger size column and the necessary adaptations required should be weighed against the cost savings of a smaller motor, associated electrical equipment, and cost of power.

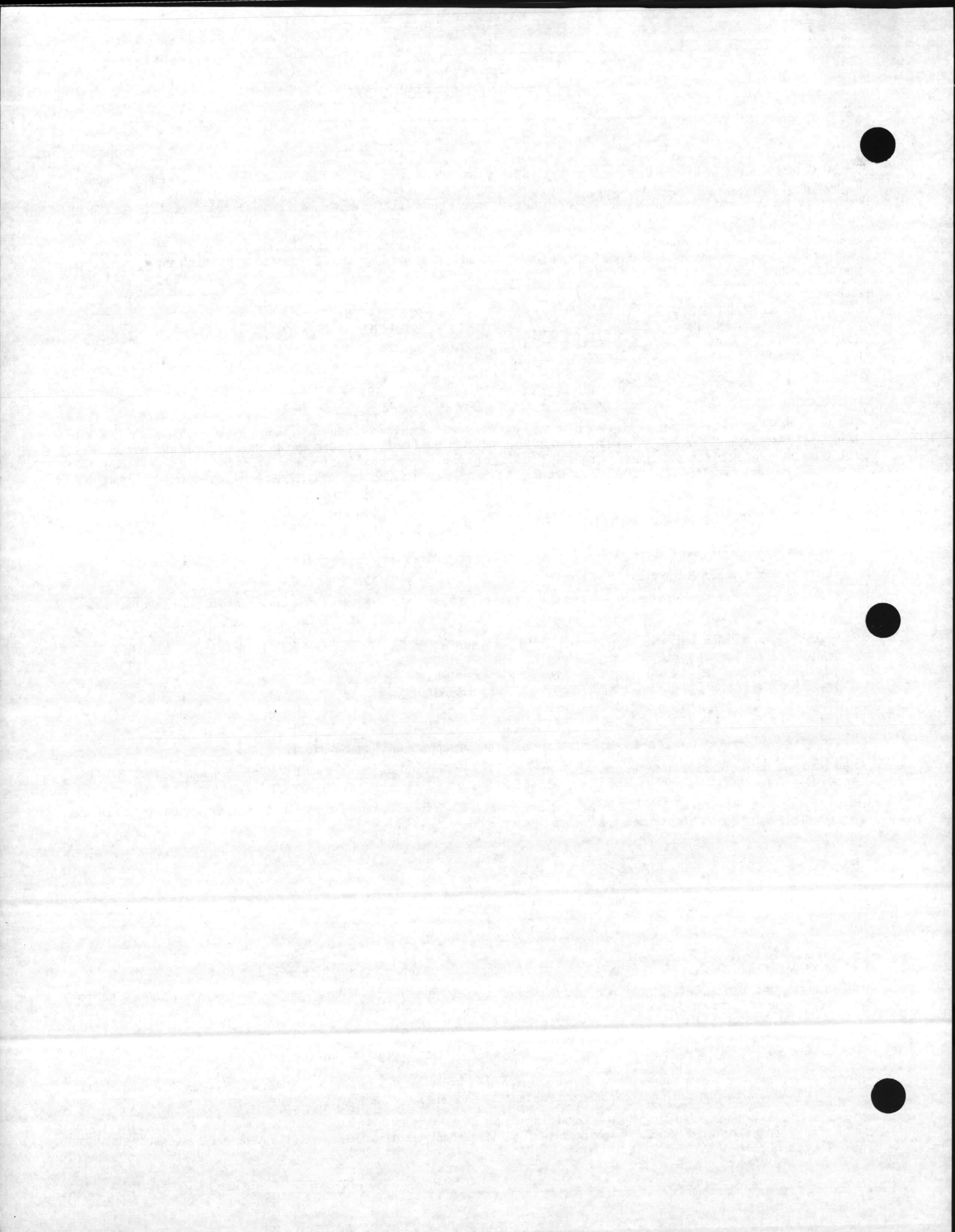

Other cases, where initial cost is the most important factor and pump settings are such that additional column friction losses are acceptable, a smaller size column could be used.

When a smaller size column is desired, a column reducing bushing is required to adapt this smaller column to the bowl used. This column reducing bushing causes additional friction losses due to the sudden reduction in size. These losses are shown in the COLUMN REDUCING BUSHING LOSS CHART on page 26.

It should be noted that a change in column size would change the relative shaft stretch and column friction losses both of which are discussed later in this text.

Since all bowls in the preliminary selection have 8" discharge case connections, we will use 8" column.

Before proceeding further, check the maximum setting allowed for the size column being used by referring to the MAXIMUM COLUMN SETTING CHART on page 27.

In the example, we are using 400 feet of 8" standard column. Referring to the MAXIMUM COLUMN SETTING CHART, we find that 400 feet is well below the maximum allowable setting of 950 feet, and can be used.

### SHAFT SELECTION

Line shaft selection is a function of horsepower requirement, shaft stretch restrictions, and thrust requirements.

Estimated bowl horsepower and thrust have been calculated above, however since the top section of lineshaft must also carry the weight of all of the shaft below it, total thrust must be calculated.

In the example, we find that the horsepower requirement ranges from 153HP to 180HP and the required thrust ranges from 3585 lbs. to 5782 lbs. Referring to the LINESHAFT RATING CHART on pages 28-30, the 1½" diameter lineshaft appears to be within this range and has a Ks value of 6.0. Now calculate the thrust due to the weight of the lineshaft by the formula:

$$\text{Thrust} = K_s \times \text{Setting}$$

Example:  $6.0 \times 400 = 2400 \text{ lbs.}$

Adding this to the bowl thrust of 5782 lbs., it is now confirmed that the 1½" diameter shaft will carry the horsepower (178) and the thrust (2400 lbs. + 5782 lbs. = 8182 lbs.) imposed on it.

### SHAFT STRETCH

This section can be ignored if pump setting is less than 50 feet.

We are not so much concerned with the lineshaft stretch as we are with the RELATIVE STRETCH between the column, enclosing tube (when required) and the lineshaft combination.

This relative stretch should be calculated and compared to the allowable shaft stretch of each bowl. Refer to the TECHNICAL DATA section of the bowl performance curve to find this value.

List the bowl size, column connection size, lineshaft size selected above, allowable shaft stretch, and the stretch constant from the appropriate chart found on pages 31 through 38 for each bowl under consideration. These charts are dependent on the shaft configuration (open or enclosed), and column wall thickness (standard or ¼ wall).

Example:

BOWL	COLUMN	SHAFT	ALLOWABLE STRETCH	STRETCH CONSTANTS	
				K	K'
11M	8" Std	1½"	.67"	5.3379	3.5401
12L	8" Std	1½"	1.07"	8.1290	3.5401
12H	8" Std	1½"	1.22"	14.5164	3.5401

The shaft stretch in each case can now be calculated simply by the following formula:

$$\text{Stretch} = \frac{L(HK + 2HK' - LK') \times \text{S.G.}}{10,000,000}$$

Where: L = Setting; H = Bowl total head; S.G. = Specific gravity

Example: 11M

$$\text{Stretch} = \frac{400 [(666 \times 5.3379) + [2 \times 666 \times 3.5401] - [400 \times 3.5401]] \times 1.0}{10,000,000} = 0.27"$$

Performing this calculation for all bowls under consideration produces the following data:

	ALLOWABLE STRETCH	CALCULATED STRETCH
	.67"	.27"
12L	1.07"	.35"
12H	1.22"	.52"

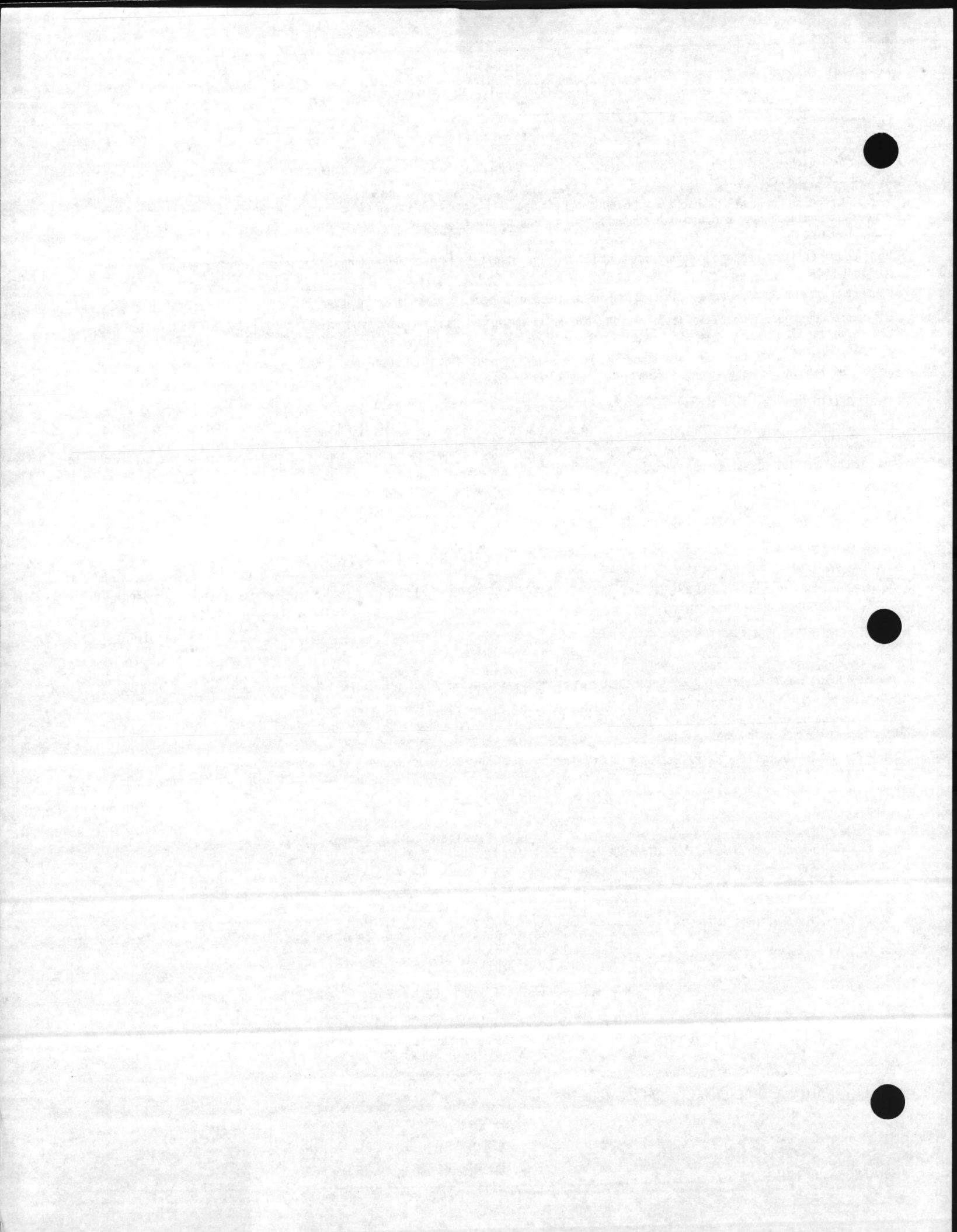

### CONFIRMATION OF BOWL SELECTION

For the purpose of this example, we will assume that lowest initial cost is the final criteria for bowl selection. Therefore the 12L bowl will be used.

Actual bowl total head can now be calculated. In the initial bowl selection, column losses were not known and thus were assumed to be 5 feet for every 100 feet of column. Since the 12L bowl, 8" column and 1 1/2" shaft have been selected, the actual friction loss can now be calculated.

Referring to the COLUMN FRICTION LOSS CHART on pages 39-42 it indicates that at 750 GPM an 8" column with 1 1/2" lineshaft (either open or enclosed) loses 2.4 feet per 100 feet of column. Therefore, the actual column friction loss is:

$$2.4 \times 400/100 = 9.6 \text{ (feet)}$$

Note that the discharge head losses have been discounted as being insignificant (typically less than 1/2 foot) when the discharge head flange size is matched to the discharge case size. This can be verified by referring to the DISCHARGE ELBOW LOSS CHART found on pages 43-45. If the discharge head loss is significant, it should be included with the column losses.

Bowl total head (exclusive of material and staging corrections) can now be calculated by the formula:

Bowl total head = Pump total head + column friction loss + discharge elbow loss

Example:  $646 + 9.6 = 655.6$  feet

Since efficiency corrections are not required in this example for either staging or material, the actual number of stages and head per stage can now be calculated.

To verify staging divide the actual bowl total head by the maximum head per stage at the desired capacity (from the pump performance curve).

Example:  $655.6/83.5 = 7.85$  or 8 stages

Required head per stage would then be the actual bowl total head divided by the number of stages required.

Example:  $655.6/8 = 82$  feet per stage

Again, since efficiency changes for staging or materials are not required, the bowl efficiency as shown on the performance curve at the conditions of 750 GPM @ 82 feet per stage total bowl head per stage is 80.3%.

If efficiency corrections were required due to staging or materials, it would necessitate a change in the head per stage. To do this, use the following formula:

Head correction due to material correction:

$$HA = HP ( [EP - EC]/EP )$$

$$EA = EP - EC$$

Head correction due to staging correction:

$$HA = HP ( [EP - .5EC]/EP )$$

$$EA = EP - EC$$

Where: HA = Head after correction  
HP = Performance curve head  
EA = Efficiency after correction  
EP = Performance curve efficiency  
EC = Efficiency change

Confirmation of staging would be calculated as follows:

Bowl total head/actual head per stage after correction = number of stages (if greater than had been previously selected, go back through procedure with this in mind.)

### DRIVER SELECTION

To make a driver selection, in this example an electric motor, both total pump thrust and brake horsepower (BHP) must be established.

Total thrust has previously been established; however, tentative bowl head was used in that calculation. Since actual total bowl head has now been established, that calculation should be redone using the correct bowl total head, and remembering to include the weight of the lineshaft as calculated previously.

Initial calculation of horsepower was based upon estimates of losses. Final selection can be made by calculating all pertinent losses. These losses are shaft loss and thrust bearing loss.

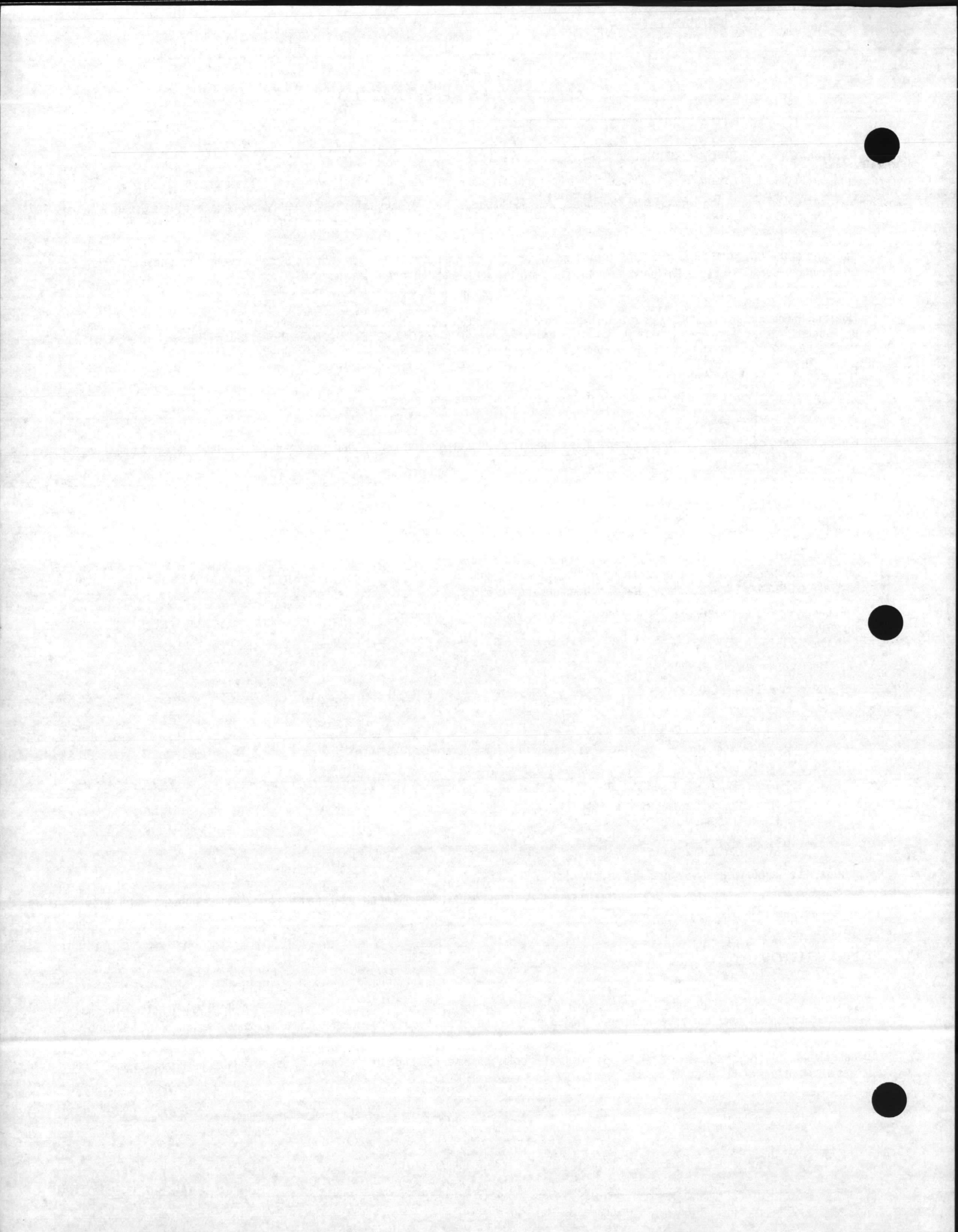



Shaft loss can be found in the chart on page 43. This chart is based on enclosed lineshaft which has bearings located on 5 foot centers. It can, however, be used for open lineshaft.

Example: 400 feet of 1½" lineshaft at 1800 RPM

$$1.20\text{HP}/100\text{ ft.} \times 400\text{ ft.} = 4.8\text{ HP}$$

Thrust bearing loss can be calculated as follows and is expressed in units of horsepower:

$$\text{HP} = .0075\text{ HP} \times (\text{Speed}/100\text{ RPM}) \times (\text{Total pump thrust}/1000\text{ lbs.})$$

Example:  $.0075 \times (1770/100) \times (6644/1000) = 0.88\text{ HP}$

Brake horsepower can now be calculated as follows:

$$\text{BHP} = ((\text{GPM} \times \text{Total head} \times \text{S.G.}) / [3960 \times \text{Bowl eff.}]) + \text{Shaft loss} + \text{Thrust bearing loss}$$

Example:

$$\text{BHP} = ((750 \times 655.6 \times 1.0) / [3960 \times .803]) + 4.8 + 0.88 = 160.3\text{ BHP}$$

Referring to the motor manufacturer's data in the VENDOR EQUIPMENT section it is established that a 200 HP motor will carry the load and the thrust of 6644 lbs. If the thrust exceeds the standard maximum thrust rating of the motor, then the motor must be ordered with an extra high thrust option.

Pump efficiency can now be calculated by the formula:

$$\text{Pump EFF} = ((\text{GPM} \times \text{bowl total head}) / [3960 \times \text{BHP}])$$

Example:  $((750 \times 655.6) / [3960 \times 160.3]) = .775 = 77.5\%$

Estimated driver input can now be calculated.

$$\text{Input HP} = \text{Output HP (nameplate)} / \text{Driver EFF (mfg. no thrust rating)}$$

Example:  $\text{Input} = 200 / .93 = 215$

Estimated driver efficiency can now be calculated.

$$\text{Eff.} = \text{Driver output (Nameplate HP)} / (\text{Driver Input} + \text{Thrust Brg. Loss})$$

Example:  $\text{Eff.} = 200 / (215 + 0.88) = .926 = 92.6\%$

NOTE: The efficiency used in this calculation is an efficiency that is obtained from the motor vendor and is a nominal value only, and not guaranteed.

It should be noted that, at the customer's option, a 150 HP motor with a 1.15 service factor (172.5 useable HP) could be used.

Overall efficiency can now be calculated using the formula:

$$\text{Overall Efficiency} = \text{Pump Efficiency} \times \text{Driver Efficiency}$$

Example:  $\text{Overall Efficiency} = 77.5\% \times 92.6\% = 71.8\%$

### CONFIRMATION OF LINESHAFT SELECTION

Having established the brake horsepower and total pump thrust, the lineshaft selection can be confirmed.

Using the BHP of 160.3 HP and the total pump thrust of 6644 lbs., refer to the LINESHAFT RATING CHART on pages 28-30 to determine whether the 1½" lineshaft is still adequate. Since the 1½" lineshaft has a maximum allowable BHP of 201 HP at 1770 RPM and at a thrust of 7500 lbs., it is still adequate for this application.

Since the setting exceeded 50 feet the shaft stretch should be rechecked using the actual bowl total head rather than the tentative bowl head used in the original calculation. Doing this we find the stretch is equal to:

$$\text{Stretch} = \frac{400 [(655.6 \times 8.129) + [2 \times 655.6 \times 3.5401] - [400 \times 3.5401] \times 1.0}{10,000,000} = 0.34"$$

This is still less than the maximum allowable and is still acceptable.

### DISCHARGE HEAD SELECTION

Discharge head size is based upon driver size, hung weight, discharge pressure, and capacity pumped. As noted under CONFIRMATION OF BOWL SELECTION the discharge head flange is typically matched to the bowl discharge case size unless the loss through the discharge head becomes significant.

Practice is to size the base diameter of the head to the base diameter of the motor.

On deep setting pumps (setting exceeding 300 feet) the most significant factor in selecting the head is whether the head can carry the hung weight load.

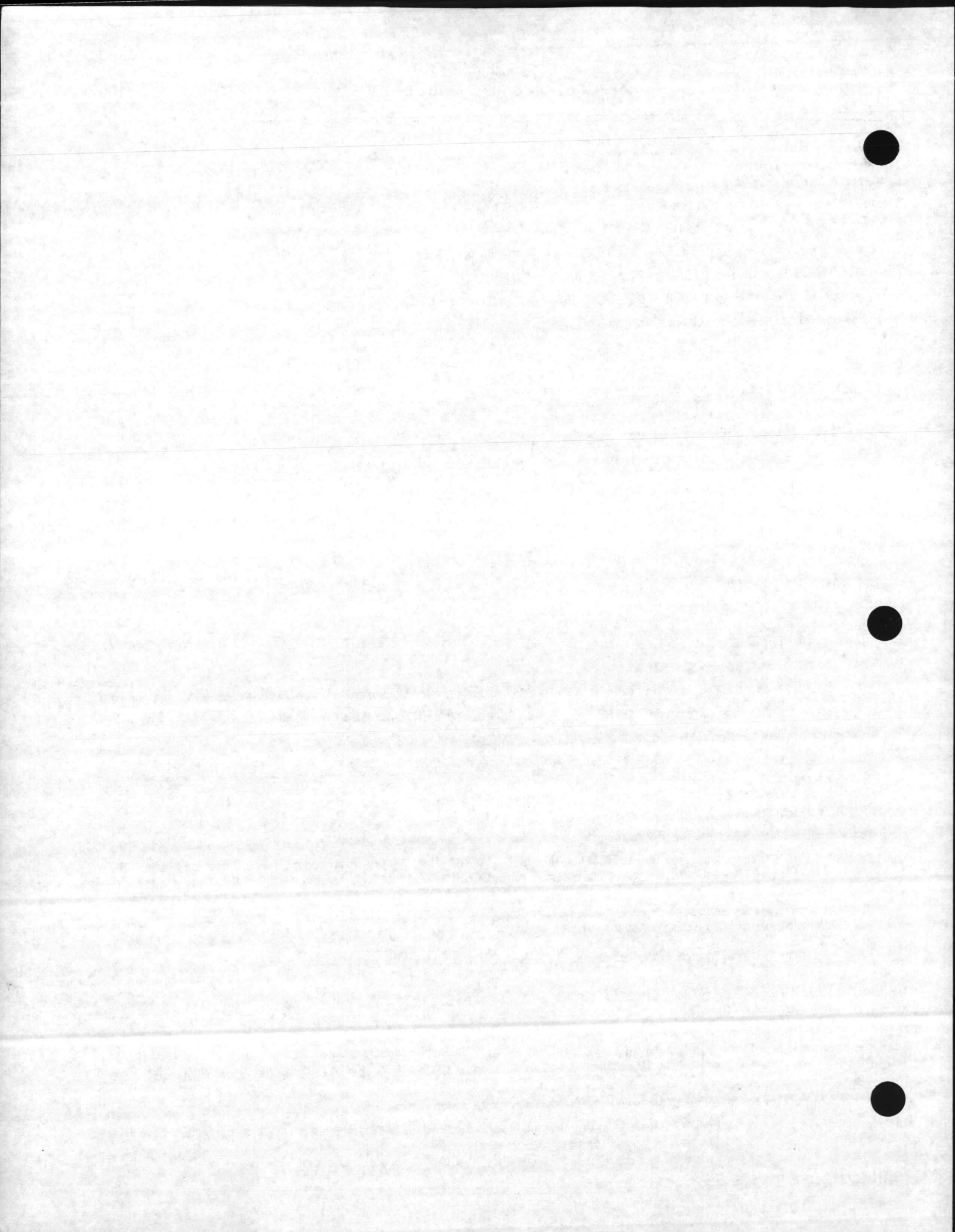

This value can be found in the DISCHARGE HEAD HANGING WEIGHT chart on page 27. The hung weight includes the bowl assembly, column pipe, shafting, enclosing tube, discharge head, and stuffing box.

Since the discharge case column size is 8" and the motor base diameter is 16 1/2" (found in motor vendor catalog) the nominal head size is 16 1/2 x 8.

To determine the correct head to use, make the following weight calculations obtaining applicable weights from the technical data section and performance curves.

Example:

8 Stg 12L Bowl Assembly	884 lbs.
400' of 8" Std. Wall Column	9880 lbs.
39-8" Column Couplings	936 lbs.
400' of 2 1/2" Enclosing Tube	3064 lbs.
79 Connector Bearings	395 lbs.
400' of 1 1/2" Lineshaft	2404 lbs.
40 Lineshaft Couplings	72 lbs.
16 1/2 x 8 "D" Discharge Head (Including stuffing box)	476 lbs.

18,111 lbs.

From the DISCHARGE HEAD HANGING WEIGHT chart, find the maximum hung weight for the heads under consideration.

The maximum allowable hung weight for 0-125 PSI discharge pressure is 15000 Lbs. For the 16 1/2 x 8 CT head, and 26500 Lbs. for the 16 1/2 x 8 D head. Therefore, only the 16 1/2 x 8 D head is suitable for this application with respect to hanging weight.

#### STUFFING BOX SELECTION

The stuffing box selection is based on the type of shaft lubrication required, the shaft size used, and the discharge pressure. The styles standardly available and most commonly used are listed below.

- A. Open Lineshaft
  - 1. Product lubricated stuffing box with conventional packing
  - 2. Mechanical shaft seals
- B. Enclosed Lineshaft.
  - 1. Oil lubricated stuffing box
  - 2. Water flush stuffing box

#### VARIATIONS

#### POT/CAN PUMPS

Can pumps are those pumps in which the bowl assembly is enclosed in a CAN. They may be referred to by many names but the most common ones are CAN, POT, TANK or BARRELL pumps.

This type of pump is most often seen as booster pumps, transfer pumps, or pumps for applications where NPSHA values are low.

It is not uncommon for this type of pump to see high temperatures, high pressures, and as previously mentioned low NPSH values.

Can pumps are normally supplied with fabricated L, or T discharge heads although there are some applications where one of the cast D heads may be used.

The following example follows the same format as the previous example of pump selection. When specific information is required it will be given. This example will not be as detailed as the previous but when required for clarity, it will be given.

Specific information must be given such as was described in PUMP SELECTION-GENERAL. Some of the ones previously specified will be valid for can pumps while some of it is not. Generally, pump operating conditions will include the following information:

User Requirements: Type of head, e.g. above grade (datum) suction and discharge or below grade (datum) suction and above grade (datum) discharge  
Location of below grade (datum) suction inlet  
Restrictions on can size

Operating Conditions: Flow rate  
Static suction pressure  
Static discharge pressure  
Differential pressure (pump total head)  
Available NPSH at what point  
Pumping temperature  
Specific gravity  
Elevation of installation  
Liquid pumped

Well Conditions: Since this application is not going into a well, no well conditions are required. It may be noted in this section, however, any limiting factors of the proposed new installation such as maximum depths that would effect can length, restrictions on can diameter, location of inlet, etc.

Accessory Requirements: No additional items

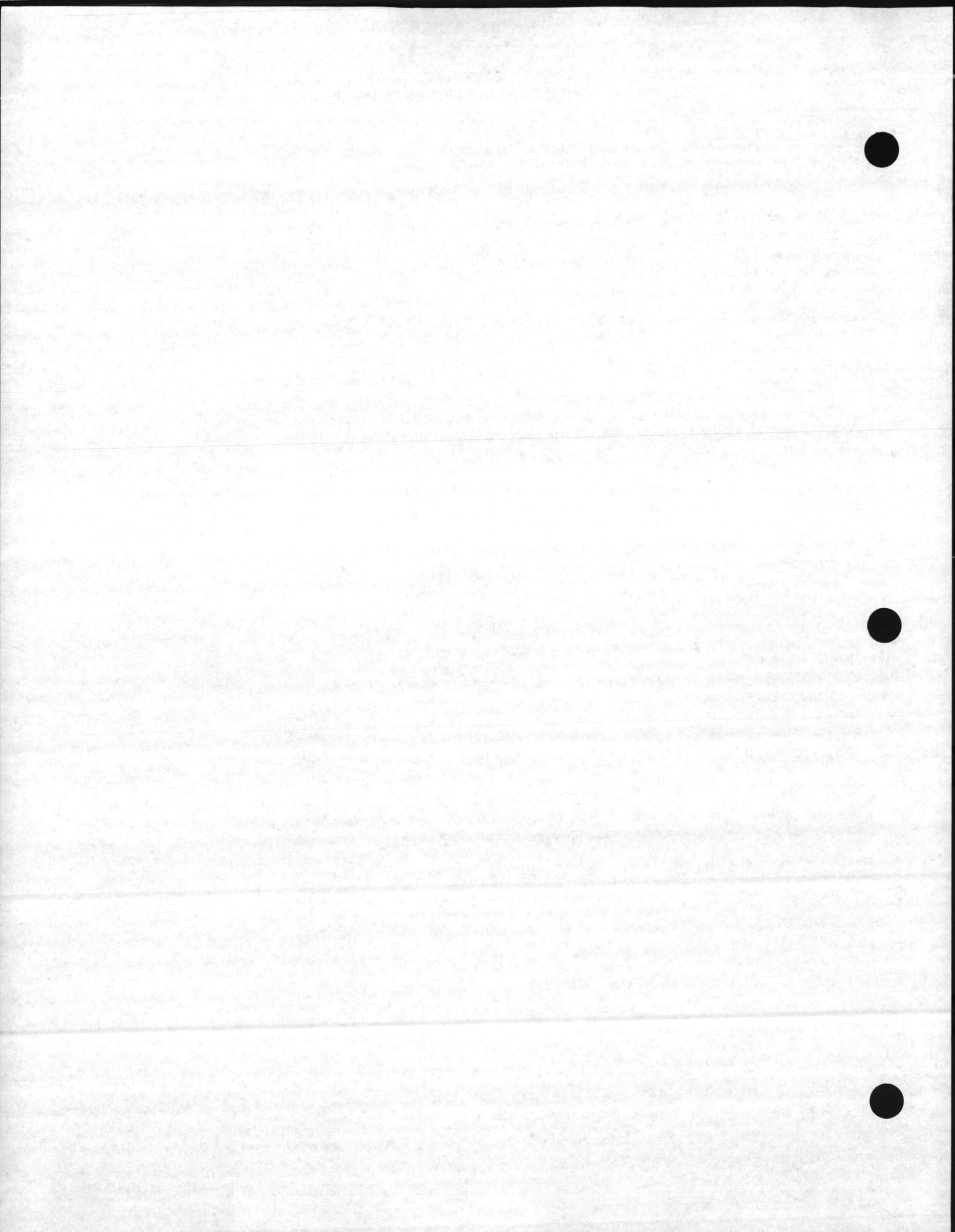

In this example we will consider the following to have been specified:

User Requirements:	Vertical solid shaft motor, product lubricated stuffing box with mechanical seal, and an inline, or T, discharge head.	
Operating Conditions:	Flow rate	750 GPM
	Static suction pressure	10 Feet
	Static discharge pressure	656 Feet
	Differential pressure	646 Feet
	Available NPSH (at datum)	5 Feet
	Pumping temperature	150 Deg F
	Specific Gravity	.981
	Elevation	2000 Feet
	Liquid Pumped:	Water
	Bowl efficiency minimum	81%
	Speed	1770 RPM

**BOWL SELECTION**

Proceed as in the previous example with the following changes:

- A. It will not be necessary to add column friction to the pump total head to determine bowl total head as there is essentially no column used, therefore the bowl total head and pump total head can be considered equal. (Again the discharge elbow losses were assumed to be small and were neglected.)
- B. No bowls are required to be eliminated due to maximum diameter (at this point).
- C. When listing the bowls in order of increasing cost include the NPSHR value for each bowl. This value is found on the performance curve.
- D. Eliminate all bowls that do not meet specified minimum bowl efficiency. In this example that requirement will eliminate all but the 11M bowl which has an efficiency of 82.5%. Since efficiency is the primary factor it would be well to make any corrections required due to special materials before proceeding further.
- E. Refer to the can selection chart on page 46, and make a preliminary CAN selection.

Example: Capacity required is 750 GPM

A 16" can when used with the 11 stage 11M bowl and the column size normally used with that bowl is acceptable for capacities up to 1513 GPM (based upon a maximum velocity of six feet per second in the suction can).

- F. Establish the approximate length of the can. To do this it is necessary to know the following:

- Bowl length
- Bell clearance
- Column length

Refer to the performance curve for the given bowl and make a note of the 1st stage length (with bell), length for each additional stage and the dimension from the bottom of the bell to the 1st impeller.

Example: 11M Bowl 1st stage with Bell	= 19.32"
Each additional stage	= 9.50"
To 1st impeller	= 4.28"

Total bowl length for a 11 stage bowl then would equal  $L = 19.32 + 10 \times 9.50 = 114.32"$

Refer to the DIMENSIONAL REFERENCE SHEET on page 268 and determine the proper bell clearance dimension.

Example: 11M bowl = 8.50"

Since the design parameters specified the available NPSH at grade, it is indicated that a T head is required since GRADE indicates the bottom of the head.

We must provide sufficient column length to supply the pump with proper NPSH at the 1st impeller.

Example: Available NPSH at grade	5 Feet
Required NPSH at 1st Impeller	14 Feet
Difference	- 9 Feet

The negative sign indicates it must be at least 9 feet from the bottom of the discharge head to the 1st (bottom) impeller.

Column length can now be calculated

Col Length = NPSH difference + dimension from 1st stage to bell - bowl total length

Example:

Column length = 9ft. x 12 in/ft + 4.28 - 114.32 in. = -2.04 in.

The negative column length indicates the additional length required for NPSH has been made up in the length of the bowl assembly and only a minimum length of column will be required.

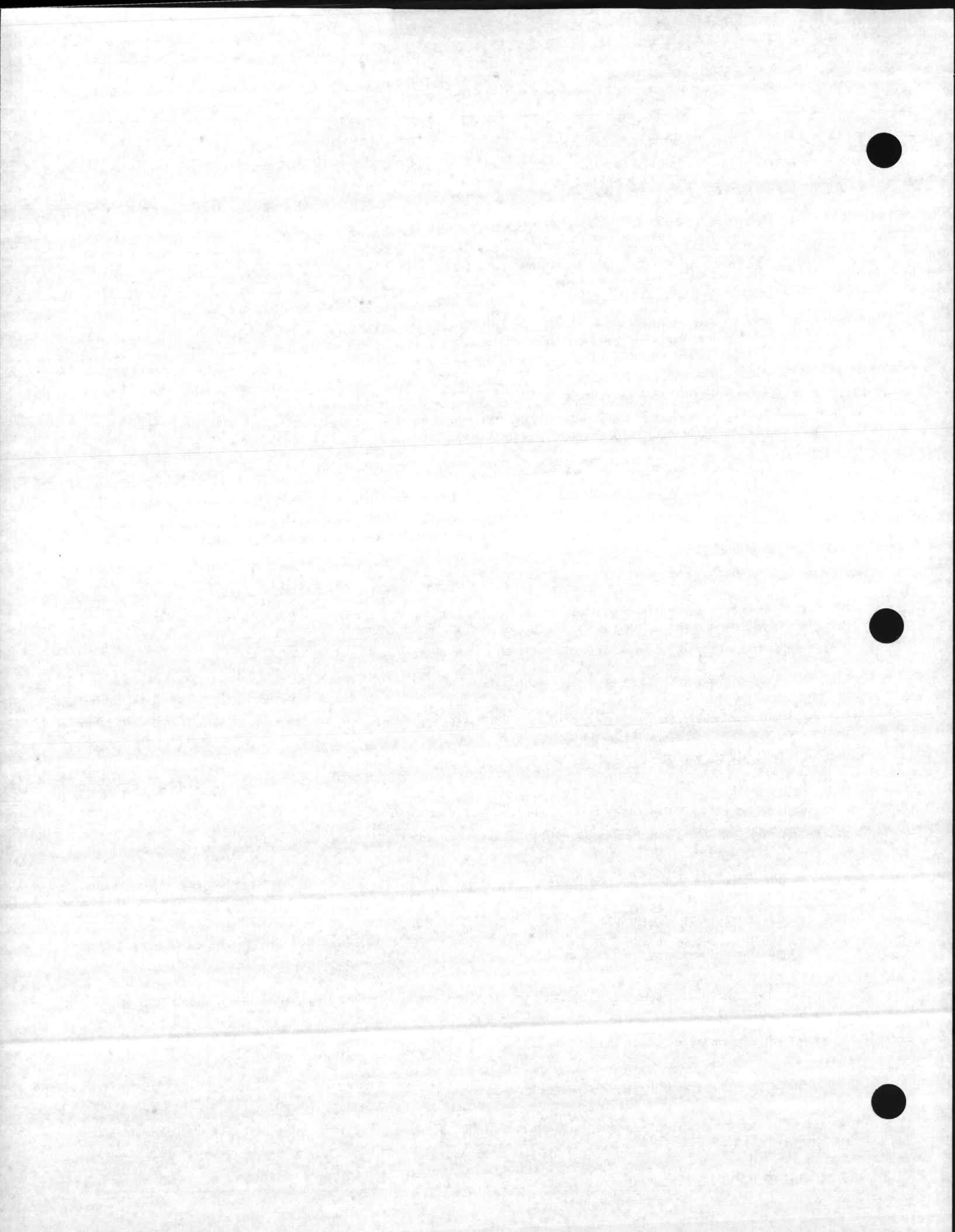

The can length can now be calculated. For this example, we will use a column length of 6". The can length would then equal the sum of the bell clearance plus the bowl length plus the column length.

Example: Bell Clearance	= 8.50"	
Bowl length	= 114.32"	
Column length	= 6.00"	
Can length	= 128.82"	= 10' - 8.82"

**COLUMN SELECTION**

Determine from the job specifications what type column is required, flanged or threaded. If flanged column is required refer to the column data on page 231 and determine what the flange diameter is, then compare with the maximum dimensions on the bowl (usually the bell diameter). If the flange diameter is larger, a larger can may be required.

**SHAFT SELECTION**

It should be noted that, in our example, a one piece impeller and lower head shaft will be required because of the use of a minimum length of column.

**LINESHAFT STRETCH**

As previously mentioned, lineshaft stretch can usually be ignored on all jobs that do not combine both high total pump heads and deep setting. If it has been noted that a particular bowl selection has a smaller than average allowable stretch and is pumping at very high pressure then lineshaft stretch may have to be considered.

**CONFIRMATION OF BOWL SELECTION**

Since column losses are not of any significance, we can proceed to any efficiency or head corrections that may be required due to any special materials.

**DRIVER SELECTION**

- A. Review job specifications for any particular requirements.
- B. For applications requiring mechanical seals it is strongly suggested that vertical solid shaft drivers with adjustable, spacer type couplings be used. If vertical hollowshaft motors are used, a steady bearing must be furnished with the motor.
- C. Since this is a short setting unit HP shaft loss will be negligible.
- D. Momentary up thrust of 30% is required.

**DISCHARGE HEAD SELECTION**

- A. Hanging weight on short setting or can type pumps is usually not a factor and can be ignored.
- B. As in the first example the discharge head flange size is matched to the discharge case size or, if a smaller than normal column is used then it is matched to the column.
- C. Refer to the discharge head data section and review all of the T type heads with 8" discharge and determine which one will be compatible with the 16" can previously selected.
- D. The discharge head should be reviewed to determine if there is enough room for an adjustable, spacer type shaft coupling, when a VSS motor is used.
- E. Make a preliminary selection of a coupling. Factors that are necessary to do this are:
  - 1. Horsepower per 100 RPM
  - 2. Maximum thrust
  - 3. Motor shaft diameter
  - 4. Pump shaft diameter

Refer to the **VENDOR EQUIPMENT** section for coupling catalogs containing dimensional information as well as selection tables. A high ring base may be necessary for use with this type of coupling.

**STUFFING BOX SELECTION SHOULD BE MADE AS PREVIOUSLY DISCUSSED**

The above examples of pump selection are meant to be a guide only, and illustrate the proper sequence of events in selecting the necessary components of a vertical turbine pump. Since one example can not meaningfully cover all of the possibilities any problems encountered in an analysis of a selection, such as excessive shaft stretch, should be referred to the factory for possible solution.

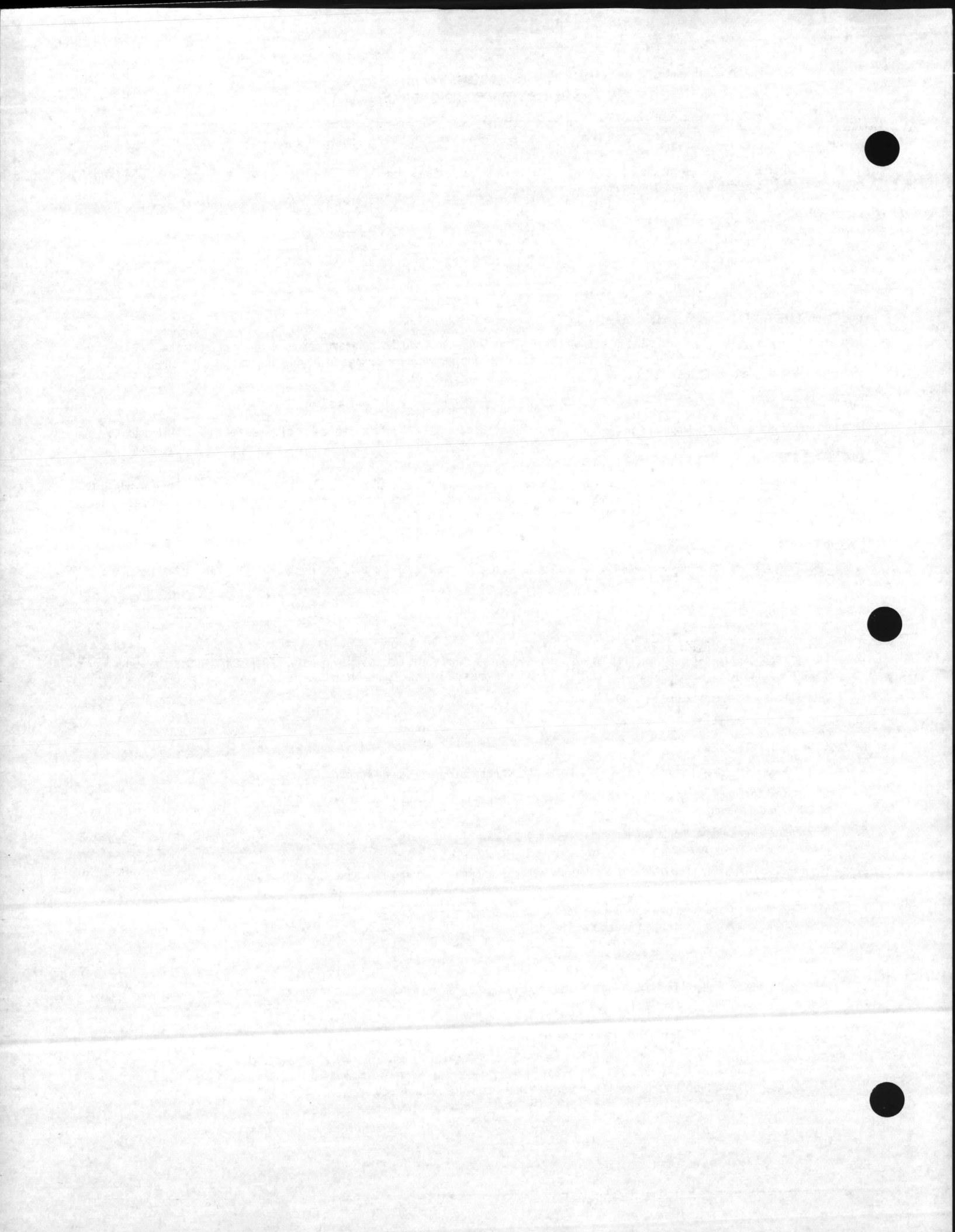



BOWL PRESSURE RATING CHART

Standard Construction(1)(2)(3)(4)			
Bowl	PSI	Bowl	PSI
6M7000	826	20MC6970	271
7M7000	823	20HC6920	390
8M7000	804	21H7000	465
10M7000	475	24MC(T4)6970	369
10XH7000	661	24MC(T6)6970	432
10XHH7000	661	24HC6920	498
11M7000	488	24XHC6920	492
11H7000	488	27M7000	377
12L7000	415	28MC6970	401
12M7000	380	28HC6920	432
12H7000	456	28XHC6920	493
12XH7000	400	30HC6920	352
13H7000	380	31M7000	485
14M7000	433	32MC6970	416
14XH7000	609	32HC6920	457
14H7000	476	32XHC6920	377
16HC6920	408	34H7000	363
16XHC6920	451	36MC6970	375
17M7000	460	36HC6920	371
17H7000	452	36XHC6920	429
18MC6920	521	42HC6920	481
18MC6970	338	48HC6920	337
18HC6920	497	57H7000	329
18XHC6920	499		

EFFICIENCY REDUCTION FOR SPECIAL MATERIALS

Pump Size and Figure Number	Bronze Bowls and Impellers	Standard Bowls with Impellers of Monel, Ni-Resist or Stainless Steel	Bowls and Impellers of Monel, Ni-Resist or Stainless Steel
6M-7000	0	3	5
7M-7000			
8M-7000	0	2.5	4
10M-7000			
10XH-7000			
11M-7000	0	2	4
11H-7000			
10XHH-7000			
12H-7000	0	3.5	8
12XH-7000			
12L-7000			
12M-7000	0	2	3
13H-7000			
14XH-7000	0	2	4
14M-7000			
15H-7000	0	2	4
16HC-6920			
16XHC-6920			
17M-7000	0	2	5
17H-7000			
18MC-6920			
18MC-6970			
18HC-6920	0	2	5
18XHC-6920			
20MC-6970			
20HC-6920	0	2	4
All Other Sizes and Figure Numbers	RTF	RTF	RTF

- Standard Construction is cast iron bowls with Grade 5 bolting.
- Maximum hydrostatic test pressure is 1.5 times PSI value shown.
- PSI limits shown are maximum pump operating pressure, including shut-off, if the pump is to operate at shut-off.
- If leak-proof bowl flange joints are required, refer to factory.

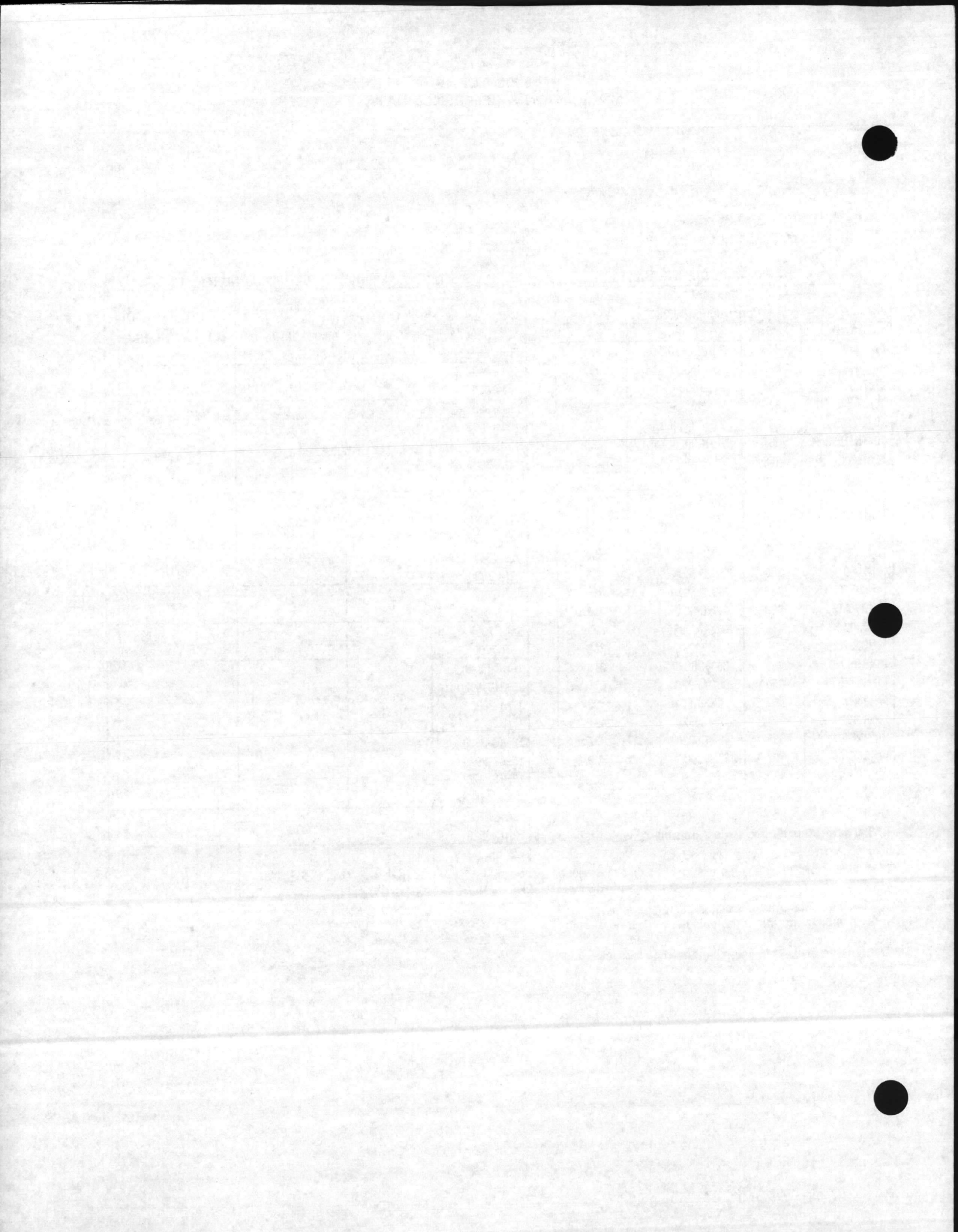

6900/7000  
APPLICATION & REFERENCE DATA

**BOWL SHAFT RATING CHART**

Shaft Size and Bowl Size	Speed (RPM)	Allowable Brake Horsepower at Thrust (lbs.) of:							
		500	1000	2000	3000	5000	7500	10000	20000
1	3550	135	135	135	134	132	127	—	—
	1770	67	67	67	67	65	63	—	—
	1170	44	44	44	44	43	42	—	—
	880	33	33	33	33	32	31	—	—
6M 7M	100	3.82	3.82	3.81	3.79	3.72	3.59	—	—
	3550	—	231	231	230	228	225	219	—
	1770	—	115	115	115	114	112	109	—
	1170	—	76	76	76	75	74	72	—
8M	880	—	57	57	57	56	55	54	—
	100	—	6.53	6.52	6.50	6.44	6.34	6.19	—
	3550	—	—	422	422	420	417	413	382
	1770	—	—	210	210	209	208	206	190
10M 10XH	1170	—	—	139	139	138	137	136	126
	880	—	—	104	104	104	103	102	94
	11M	705	—	84	83	83	82	82	76
	11H	100	—	11.91	11.90	11.86	11.77	11.65	10.78
11 <sup>1</sup> / <sub>16</sub>	3550	—	—	698	698	697	694	690	665
	1770	—	—	348	348	347	346	344	331
	10XHH	1170	—	230	230	229	228	227	219
	12L	880	—	173	173	172	172	171	164
12M 12H 13H	12M	705	—	138	138	138	137	137	132
	12H	585	—	115	115	114	114	113	109
	13H	100	—	19.68	19.67	19.63	19.56	19.46	18.75

		3000	5000	7500	10000	20000	30000	50000	65000
1 <sup>5</sup> / <sub>16</sub>	3550	1075	1074	1072	1068	1047	1010	—	—
	1770	536	535	534	532	522	503	—	—
	12XH	1170	354	354	353	352	345	332	—
	14M	880	266	266	265	264	259	250	—
	14XH	705	213	213	212	212	207	200	—
	15H	585	177	177	176	176	172	166	—
2 <sup>3</sup> / <sub>16</sub>	100	30.29	30.26	30.20	30.11	29.50	28.46	—	—
	1770	793	793	792	790	781	765	—	—
	1170	524	524	523	522	516	506	—	—
	16HC	880	394	394	393	393	388	380	—
	17M	705	316	315	315	315	311	304	—
	17H	585	262	262	261	261	258	253	—
	505	226	226	226	225	222	218	—	—
	100	44.84	44.82	44.76	44.68	44.15	43.25	—	—

1. Above chart is based on ASTM-A582-416 shaft material.
2. For ratings other than those shown above use the following formula:
3. Multipliers for various shaft materials.

$$\text{BHP (Allowed)} = \frac{\text{RPM}}{100} \times \text{BHP @ 100 RPM}$$

Example: 1<sup>1</sup>/<sub>16</sub>" shaft @ 2300 RPM, 5000 lbs. Thrust

$$\text{BHP (Allowed)} = \frac{2300}{100} \times 20.02 = 460.46 \text{ HP.}$$

Type	Multipliers	
	1"-2 <sup>3</sup> / <sub>16</sub> "	2 <sup>7</sup> / <sub>16</sub> "-5 <sup>1</sup> / <sub>2</sub> "
304/316	.55	.5
17-4PH	1.45	1.4
Monel	.7	.65
K-Monel	1.45	1.4

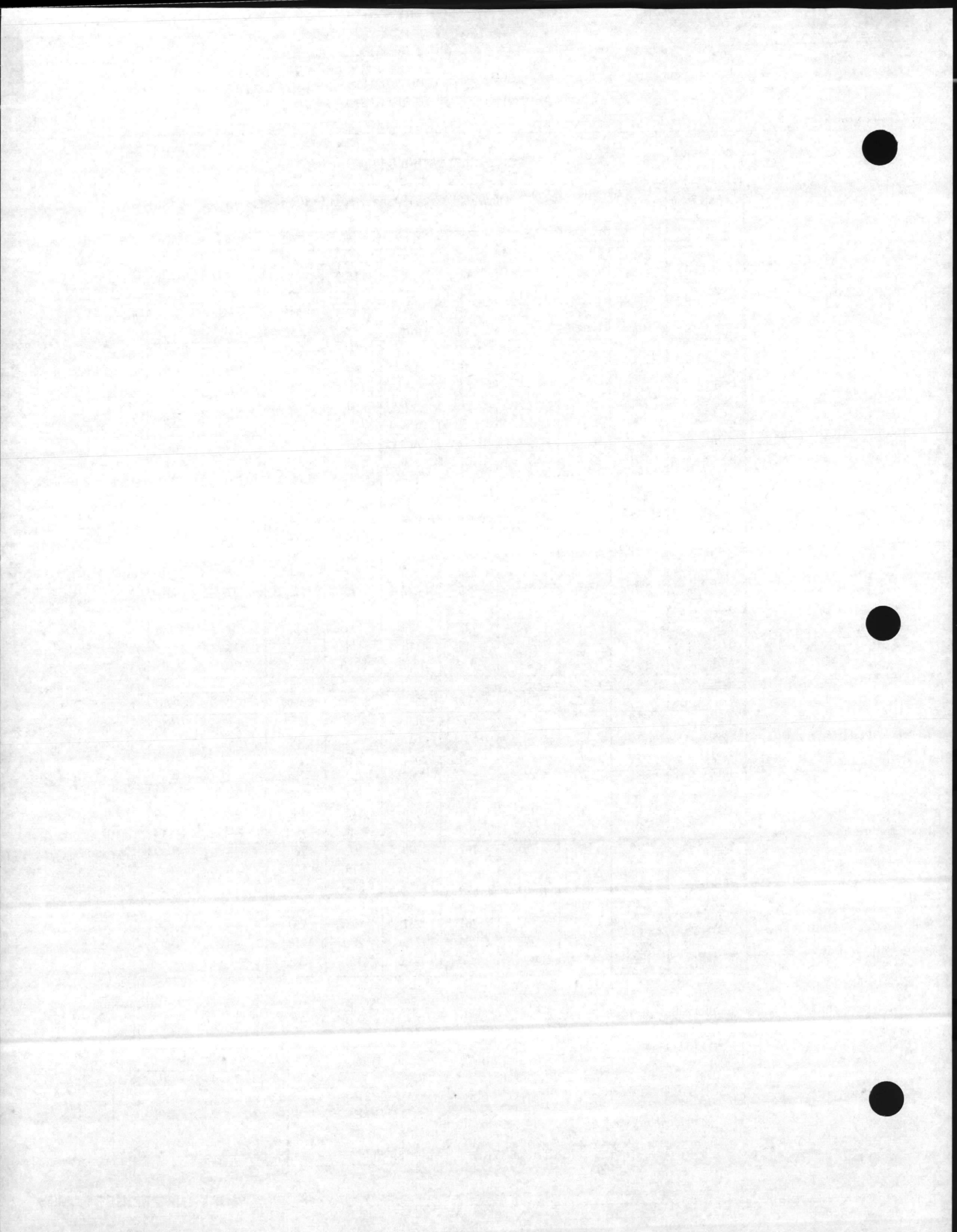

6900/7000  
APPLICATION & REFERENCE DATA

BOWL SHAFT RATING CHART

Shaft Size and Bowl Size	Speed (RPM)	Allowable Brake Horsepower at Thrust (lbs.) of:							
		3000	5000	7500	10000	20000	30000	50000	65000
2 <sup>7</sup> / <sub>16</sub>	1770	—	1154	1153	1152	1143	1129	1084	—
	1170	—	762	762	761	756	746	716	—
	16XHC 880	—	573	573	572	568	561	539	—
	18MC 705	—	459	459	458	455	450	431	—
	(6920) 585	—	381	381	380	378	373	358	—
18HC 505	—	329	329	328	326	322	309	—	
100	—	65.21	65.16	65.09	64.62	63.84	61.25	—	
2 <sup>7</sup> / <sub>16</sub>	1770	—	1073	1072	1071	1061	1043	986	—
	1170	—	709	709	708	701	689	651	—
	18XHC 880	—	533	533	532	527	518	490	—
	705	—	427	427	426	422	415	392	—
	585	—	354	354	354	350	344	325	—
505	—	306	306	305	302	297	281	—	
100	—	60.67	60.61	60.53	59.95	58.97	55.71	—	
2 <sup>7</sup> / <sub>16</sub>	1770	—	1073	1072	1071	1061	1043	986	—
	1170	—	709	709	708	701	689	651	—
	21H 880	—	533	533	532	527	518	490	—
	705	—	427	427	426	422	415	392	—
	585	—	354	354	354	350	344	325	—
505	—	306	306	305	302	297	281	—	
100	—	60.67	60.61	60.53	59.95	58.97	55.71	—	
2 <sup>1</sup> / <sub>2</sub>	1170	—	751	751	750	744	735	705	—
	880	—	565	565	564	560	553	530	—
	18MC 705	—	453	452	452	448	443	425	—
	(6970) 585	—	375	375	375	372	367	352	—
	20MC 505	—	324	324	323	321	317	304	—
(6970) 100	—	64.26	64.21	64.14	63.67	62.88	60.29	—	
2 <sup>11</sup> / <sub>16</sub>	1170	—	1024	1024	1023	1018	1010	983	—
	880	—	770	770	769	766	759	739	—
	20HC 705	—	617	617	616	613	608	592	—
	580	—	512	512	511	509	505	491	—
	505	—	442	442	441	439	436	424	—
100	—	87.58	87.54	87.48	87.05	86.35	84.04	—	
3 <sup>3</sup> / <sub>16</sub>	1170	—	1589	1588	1588	1582	1574	1546	—
	880	—	1195	1195	1194	1190	1184	1163	—
	27M 705	—	957	957	956	953	948	931	—
	585	—	794	794	794	791	787	773	—
	505	—	686	685	685	683	679	667	—
100	—	135.84	135.80	135.73	135.29	134.55	132.16	—	

- Above chart is based on ASTM-A582-416 shaft material.
- For ratings other than those shown above use the following formula:
- Multipliers for various shaft materials.

$$\text{BHP (Allowed)} = \frac{\text{RPM}}{100} \times \text{BHP @ 100 RPM}$$

Example: 1<sup>11</sup>/<sub>16</sub>" shaft @ 2300 RPM, 5000 lbs. Thrust

$$\text{BHP (Allowed)} = \frac{2300}{100} \times 20.02 = 460.46 \text{ HP.}$$

Type	Multipliers	
	1"-2 <sup>3</sup> / <sub>16</sub> "	2 <sup>7</sup> / <sub>16</sub> "-5 <sup>1</sup> / <sub>2</sub> "
304/316	.55	.5
17-4PH	1.45	1.4
Monel	.7	.65
K-Monel	1.45	1.4

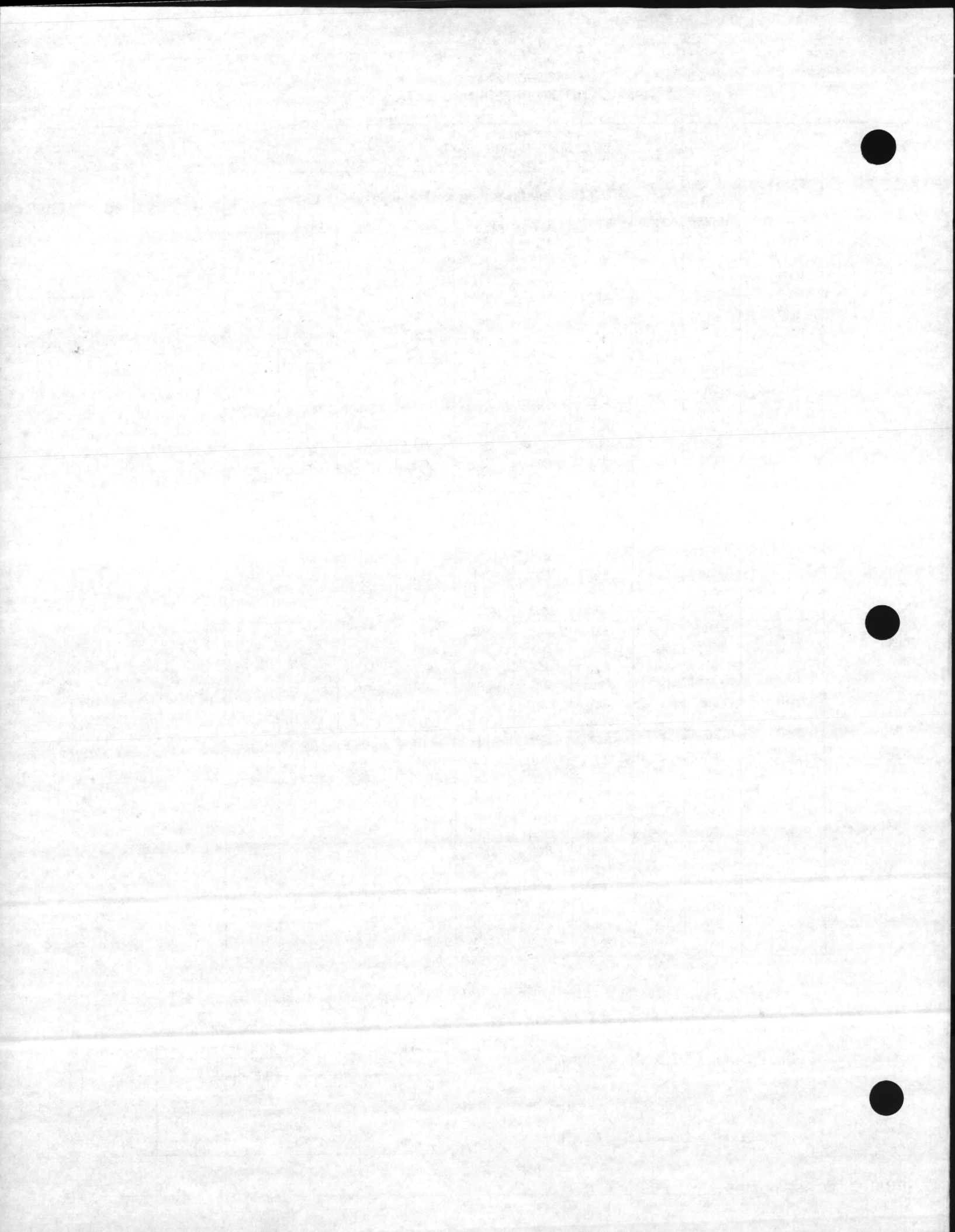

6900/7000  
APPLICATION & REFERENCE DATA

BOWL SHAFT RATING CHART

Shaft Size and Bowl Size	Speed (RPM)	Allowable Brake Horsepower at Thrust (lbs.) of:						
		3000	5000	7500	10000	20000	30000	50000
3 <sup>7</sup> / <sub>16</sub>	1170	—	1993	1993	1992	1987	1979	1954
	880	—	1499	1499	1498	1495	1489	1469
	24MC	705	—	1201	1201	1200	1197	1193
	24XHC	585	—	996	996	996	993	989
	28MC	505	—	860	860	860	858	854
	100	—	170.42	170.38	170.32	169.91	169.23	167.02
3 <sup>1</sup> / <sub>16</sub>	1170	—	2461	2461	2460	2456	2448	2424
	880	—	1851	1851	1850	1847	1841	1823
	31M	705	—	1483	1483	1482	1480	1475
	34H	585	—	1230	1230	1230	1228	1224
		505	—	1062	1062	1062	1060	1056
	100	—	210.41	210.37	210.32	209.94	209.30	207.25

		15000	20000	30000	50000	65000	85000	
4	880	1928	1927	1922	1908	1892	—	
24HC	705	1545	1544	1540	1528	1515	—	
28HC	585	1282	1281	1278	1268	1257	—	
28XHC	505	1106	1106	1103	1094	1085	—	
30HC	440	964	963	961	954	946	—	
32MC	100	219.19	219.01	218.49	216.83	215.02	—	
4 <sup>1</sup> / <sub>2</sub>	880	2695	2693	2689	2676	2662	—	
	705	2159	2158	2154	2144	2132	—	
	36MC	585	1791	1790	1788	1779	1769	—
		505	1546	1545	1543	1536	1527	—
		440	1347	1346	1344	1338	1331	—
	100	306.27	306.11	305.65	304.16	302.55	—	
5	880	3693	3692	3688	3676	3664	—	
	705	2959	2958	2955	2945	2935	—	
	32HC	585	2455	2454	2452	2444	2435	—
	32XHC	505	2119	2118	2116	2110	2102	—
	36HC	440	1846	1846	1844	1838	1832	—
36XHC	100	419.73	419.58	419.16	417.83	416.38	—	
5 <sup>1</sup> / <sub>2</sub>	880	4975	4974	4971	4960	4949	4929	
	705	3986	3985	3982	3974	3965	3949	
	48HC	585	3307	3307	3304	3297	3290	3276
	57H	505	2855	2854	2852	2846	2840	2828
		440	2487	2487	2485	2480	2474	2464
	100	565.45	565.32	564.94	563.74	562.43	560.15	

1. Above chart is based on ASTM-A582-416 shaft material.
2. For ratings other than those shown above use the following formula:
3. Multipliers for various shaft materials.

$$\text{BHP (Allowed)} = \frac{\text{RPM}}{100} \times \text{BHP @ 100 RPM}$$

Example: 1<sup>1</sup>/<sub>16</sub>" shaft @ 2300 RPM, 5000 lbs. Thrust

$$\text{BHP (Allowed)} = \frac{2300}{100} \times 20.02 = 460.46 \text{ HP.}$$

Type	Multipliers	
	1"-2 <sup>3</sup> / <sub>16</sub> "	2 <sup>7</sup> / <sub>16</sub> "-5 <sup>1</sup> / <sub>2</sub> "
304/316	.55	.5
17-4PH	1.45	1.4
Monel	.7	.65
K-Monel	1.45	1.4

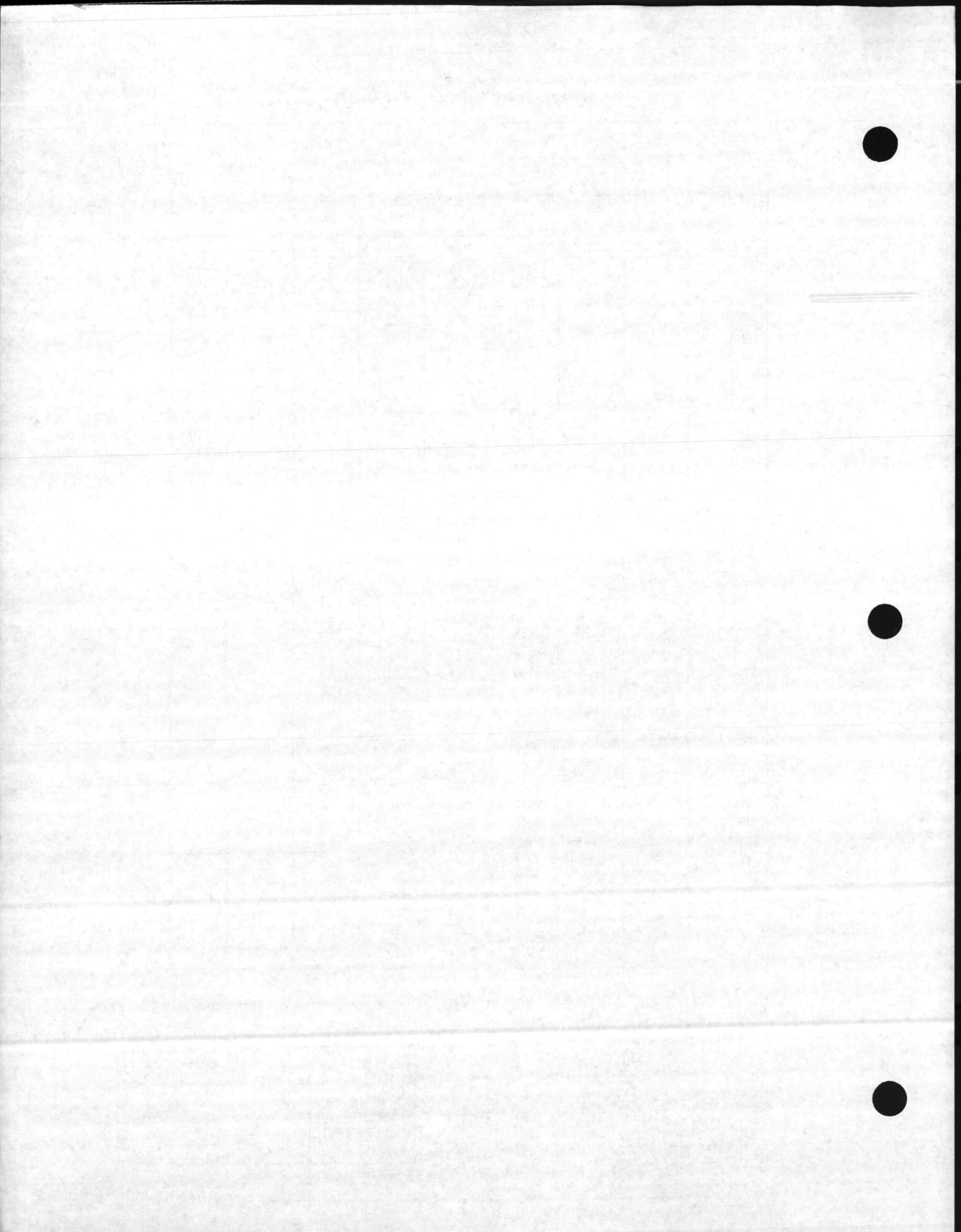



6900/7000  
APPLICATION & REFERENCE DATA

COLUMN REDUCING BUSHING LOSS CHART

Size	Pump	Head Loss in Feet at Flow (GPM) Of:										
		100	150	200	300	400	500	600	700	800		
4 x 5	6M	0.9	2.0	3.5	7.8	13.9	21.7					
	7M											
6 x 4	8M			6.1	13.6	24.2	37.9	54.5				
	10M			2.7	6.0	10.7	16.7	24.0	32.7	42.7		
6 x 5	8M			1.3	3.0	5.3	8.3	12.0	16.3	21.3		
	10M			1.9	4.3	7.6	11.9	17.1	23.3	30.5		
		400	600	800	1000	1200	1400	1600	1800	2000		
8 x 6	10XH	2.4	5.5	9.7	15.2	21.8	29.7	38.8	49.1	60.6		
	11M											
	11H											
	12L											
	12M											
	12H											
		1000	1200	1400	1600	1800	2000	2200	2400	2600	2800	3000
10 x 8	13H	3.7	5.3	7.2	9.4	11.9	14.7	17.8	21.2	24.9	28.8	
	12XH	5.0	7.2	9.8	12.8	16.2	20.0	24.2	28.8	33.8	39.2	45.0
	14M											
		1200	1400	1600	1800	2000	2200	2400	2800	3200	3600	4000
12 x 10	14XH	2.2	3.0	3.9	5.0	6.2	7.5	8.9	12.1	15.8	19.9	24.6
	15H											
	16H											
		2000	2500	3000	3500	4000	4500	5000	5500	6000	6500	7000
14 x 12	17M	2.7	4.2	6.0	8.2	10.7	13.5	16.7	20.2	24.0	28.2	32.7
	17H											

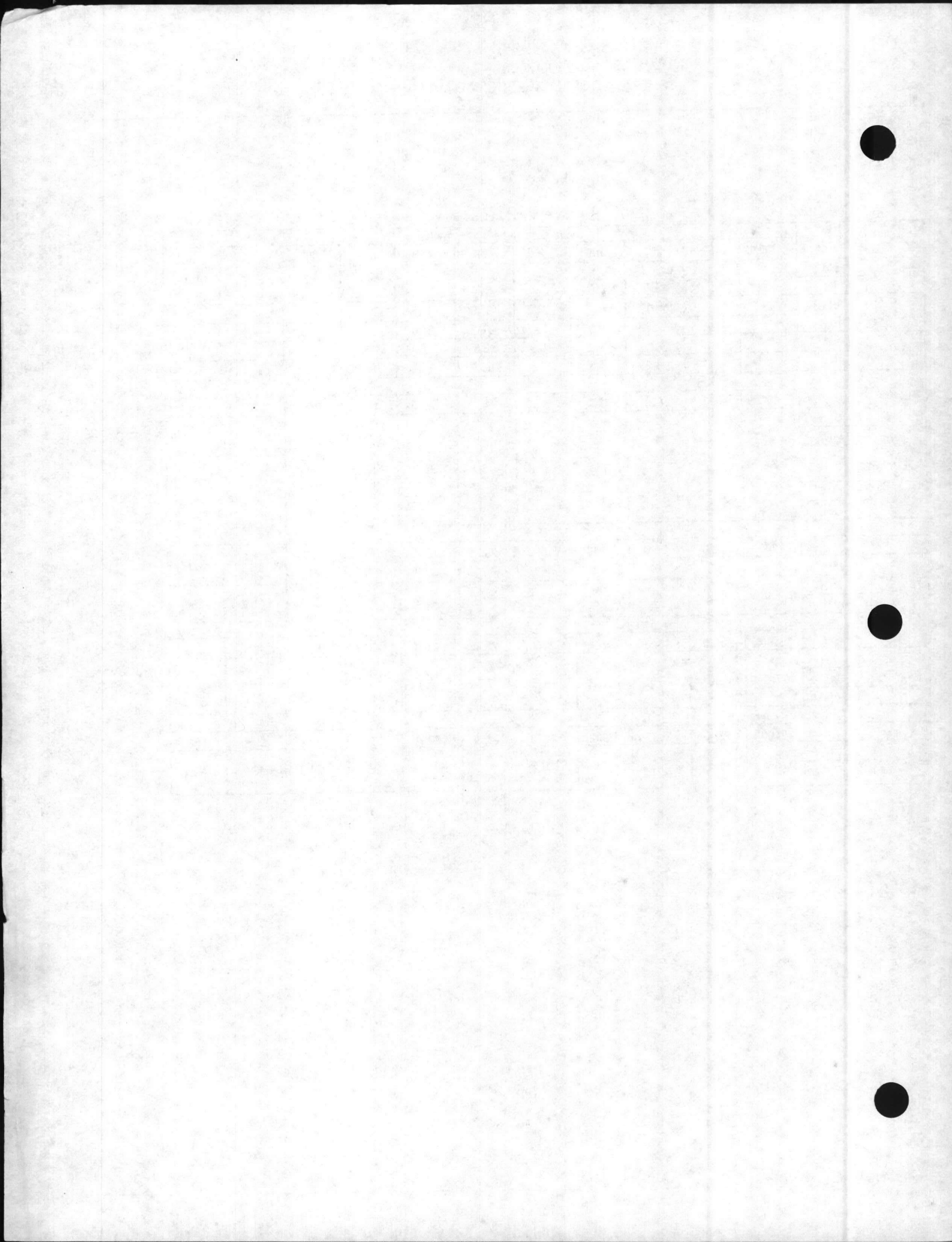

MAXIMUM COLUMN SETTING CHART

Column Size	Schedule Number	Wall Thickness	Maximum Settings			
			Threaded Column	Total Weight	Flanged Column	Total Weight
4"	40	.237"	1,100 Ft.	12,000 lbs.	300 Ft.	3,200 lbs.
5"	40	.258"	1,100 Ft.	16,000 lbs.	300 Ft.	4,400 lbs.
6"	40	.280"	1,100 Ft.	21,000 lbs.	400 Ft.	7,600 lbs.
8"	30	.277"	950 Ft.	23,500 lbs.	400 Ft.	9,900 lbs.
10"	—	.279"	800 Ft.	25,000 lbs.	350 Ft.	11,000 lbs.
12"	30	.330"	900 Ft.	39,500 lbs.	350 Ft.	15,500 lbs.
14"	30	.375"	1,000 Ft.	55,000 lbs.	300 Ft.	16,500 lbs.
16"	30	.375"	—	—	300 Ft.	19,000 lbs.
18"	NA	.375"	—	—	350 Ft.	25,000 lbs.
20"	20	.375"	—	—	350 Ft.	27,500 lbs.
24"	20	.375"	—	—	350 Ft.	33,000 lbs.
30"	NA	.375"	—	—	325 Ft.	38,000 lbs.
36"	NA	.375"	—	—	325 Ft.	46,500 lbs.

DISCHARGE HEAD HANGING WEIGHT CHART

Hanging Weight (lbs.) (1)						
Discharge Head	12 x 4 "C"	16½ x 6 "CT"	16½ x 8 "CT"	16½ x 10 "C"	20 x 12 "H"	24½ x 14 "H"
Discharge Pressure	0-125 PSI	0-125 PSI	0-125 PSI	0-125 PSI	0-125 PSI	0-125 PSI
Column Size						
4"	9,000	—	—	20,000	—	—
6"	9,000	11,500	—	20,000	—	—
8"	—	—	15,000	20,000	20,000	—
10"	—	—	—	20,000	20,000	20,000
12"	—	—	—	20,000	20,000	20,000
14"	—	—	—	—	—	20,000

Hanging Weight (lbs.) (1)												
Discharge Head	12 x 4 "D"			16½ x 6 "D"			16½ x 8 "D"			20 x 10 "D"		
	0-125 PSI	126-250 PSI	251-400 PSI	0-125 PSI	126-250 PSI	251-400 PSI	0-125 PSI	126-250 PSI	251-400 PSI	0-125 PSI	126-250 PSI	251-400 PSI
Column Size												
4"	13,000	7,000	—	13,000	7,000	-0-	—	—	—	—	—	—
6"	—	—	—	21,500	15,000	7,000	21,500	15,000	7,000	21,500	15,000	7,000
8"	—	—	—	25,000	21,000	15,000	26,500	21,000	15,000	26,500	21,000	15,000
10"	—	—	—	—	—	—	29,000	24,000	18,000	29,000	24,000	18,000
12"	—	—	—	—	—	—	32,000	28,000	23,000	32,000	28,000	23,000

1. Weight includes column, shaft, enclosing tube, connector bearing, bowl assembly, and discharge head.
2. On "H" heads, the weight limit is based on using two nylon slings through the windows, with the driver attached to the head.



6900/7000  
APPLICATION & REFERENCE DATA

LINESHAFT RATING CHART

Shaft Size and Weight per Ft.	Speed (RPM)	Allowable Brake Horsepower at Thrust (lbs.) of:							
		500	1000	2000	3000	5000	7500	10000	20000
1" $K_S = 2.8$	3550	126	126	125	124	122	117	—	—
	1770	62	62	62	62	61	58	—	—
	1170	41	41	41	41	40	38	—	—
	880	30	30	30	30	30	28	—	—
	100	3.6	3.6	3.5	3.5	3.4	3.3	—	—
1 1/4" $K_S = 4.2$	3550	—	234	233	232	231	227	221	—
	1770	—	116	116	116	115	113	110	—
	1170	—	77	77	76	76	74	73	—
	880	—	57	57	57	56	55	54	—
	100	—	6.6	6.6	6.6	6.5	6.4	6.2	—
1 1/2" $K_S = 6.0$	3550	—	—	410	409	407	404	399	364
	1770	—	—	204	204	203	201	199	181
	1170	—	—	135	135	134	133	131	120
	880	—	—	100	100	99	99	97	82
	705	—	—	81	81	81	80	79	72
	100	—	—	11.6	11.5	11.5	11.4	11.3	10.3
1 11/16" $K_S = 8.1$	3550	—	—	605	604	603	600	596	566
	1770	—	—	301	301	300	299	297	282
	1170	—	—	199	199	198	197	196	186
	880	—	—	148	148	147	147	146	138
	705	—	—	120	120	119	119	118	112
	585	—	—	99	99	99	98	98	93
	100	—	—	17.1	17.0	17.0	16.9	16.8	16.0

Size	RPM	3000	5000	7500	10000	20000	30000	50000	65000
1 5/16" $K_S = 10.6$	3550	918	916	913	909	877	823	—	—
	1770	457	457	455	453	437	410	—	—
	1170	302	302	301	299	289	271	—	—
	880	225	224	223	222	215	201	—	—
	705	182	182	181	180	174	163	—	—
	585	151	151	150	149	144	135	—	—
	100	25.87	25.82	25.73	25.61	24.73	23.20	—	—
2 3/16" $K_S = 13.6$	1770	620	620	618	616	601	577	—	—
	1170	410	409	408	407	397	381	—	—
	880	305	304	303	302	295	283	—	—
	705	247	246	246	245	239	229	—	—
	585	205	204	204	203	198	190	—	—
	505	177	176	176	175	171	164	—	—
	100	35.07	35.03	34.94	34.82	34.01	32.60	—	—

- Above chart is based on AISI-1045 material.
- For ratings other than those shown above use the following formula:

$$\text{BHP (Allowed)} = \frac{\text{RPM}}{100} \times \text{BHP @ 100 RPM}$$

Example: 1 11/16" shaft @ 2300 RPM, 5000 lbs. Thrust

$$\text{BHP (Allowed)} = \frac{2300}{100} \times 17.0 = 391.0 \text{ HP}$$

- Multipliers for various shaft materials.

Type	Multipliers	
	1"-2 3/16"	2 7/16" & Larger
416	1.1	1.2
304/316	.6	.6
17-4PH	1.6	1.7
Monel	.8	.8
K-Monel	1.6	1.7

- 4" diameter lineshaft & larger use sleeve couplings.



6900/7000  
APPLICATION & REFERENCE DATA

**LINESHAFT RATING CHART**

Shaft Size and Weight per Ft.	Speed (RPM)	Allowable Brake Horsepower at Thrust (lbs.) of:							
		3000	5000	7500	10000	20000	30000	50000	65000
2 <sup>7</sup> / <sub>16</sub>  K <sub>S</sub> = 17.0	1770	—	859	857	855	842	820	745	—
	1170	—	568	566	565	557	542	493	—
	880	—	422	421	420	414	403	366	—
	705	—	342	341	340	335	326	297	—
	585	—	284	283	282	278	271	246	—
	505	—	245	244	244	240	234	212	—
	100	—	48.57	48.44	48.33	47.60	46.36	42.14	—
2 <sup>11</sup> / <sub>16</sub>  K <sub>S</sub> = 21.0	1770	—	1151	1150	1148	1137	1117	1051	—
	1170	—	761	760	759	751	738	695	—
	880	—	566	565	564	558	549	517	—
	705	—	458	458	457	452	445	418	—
	585	—	380	380	379	375	369	347	—
	505	—	328	328	327	324	318	300	—
	100	—	65.07	65.00	64.90	64.24	63.13	59.43	—
2 <sup>15</sup> / <sub>16</sub>  K <sub>S</sub> = 25.0	1770	—	—	1508	1506	1495	1477	1419	—
	1170	—	—	996	995	988	976	938	—
	880	—	—	741	740	735	726	697	—
	705	—	—	600	599	595	588	565	—
	585	—	—	498	497	494	488	469	—
	505	—	—	430	429	426	421	405	—
	100	—	—	85.2	85.1	84.5	83.5	80.2	—
3 <sup>3</sup> / <sub>16</sub>  K <sub>S</sub> = 27.1	1170	—	—	—	1272	1265	1255	1220	—
	880	—	—	—	946	941	933	907	—
	705	—	—	—	767	762	756	735	—
	585	—	—	—	636	632	627	610	—
	505	—	—	—	549	546	541	526	—
	440	—	—	—	478	476	472	458	—
	100	—	—	—	108.8	108.2	107.3	104.3	—
3 <sup>7</sup> / <sub>16</sub>  K <sub>S</sub> = 31.6	1170	—	—	—	1597	1591	1580	1547	—
	880	—	—	—	1187	1183	1175	1151	—
	705	—	—	—	980	958	952	932	—
	585	—	—	—	798	795	790	773	—
	505	—	—	—	689	686	682	668	—
	440	—	—	—	600	598	594	582	—
	100	—	—	—	136.5	136.0	135.1	132.3	—

- Above chart is based on AISI-1045 material.
- For ratings other than those shown above use the following formula:

$$\text{BHP (Allowed)} = \frac{\text{RPM}}{100} \times \text{BHP @ 100 RPM}$$

Example: 1<sup>11</sup>/<sub>16</sub>" shaft @ 2300 RPM, 5000 lbs. Thrust

$$\text{BHP (Allowed)} = \frac{2300}{100} \times 17.0 = 391.0 \text{ HP}$$

- Multipliers for various line shaft materials.

Type	Multipliers	
	1"-2 <sup>3</sup> / <sub>16</sub> "	2 <sup>7</sup> / <sub>16</sub> " & Larger
416	1.1	1.2
304/316	.6	.6
17-4PH	1.6	1.7
Monel	.8	.8
K-Monel	1.6	1.7

- 4" diameter lineshaft & larger use sleeve couplings.

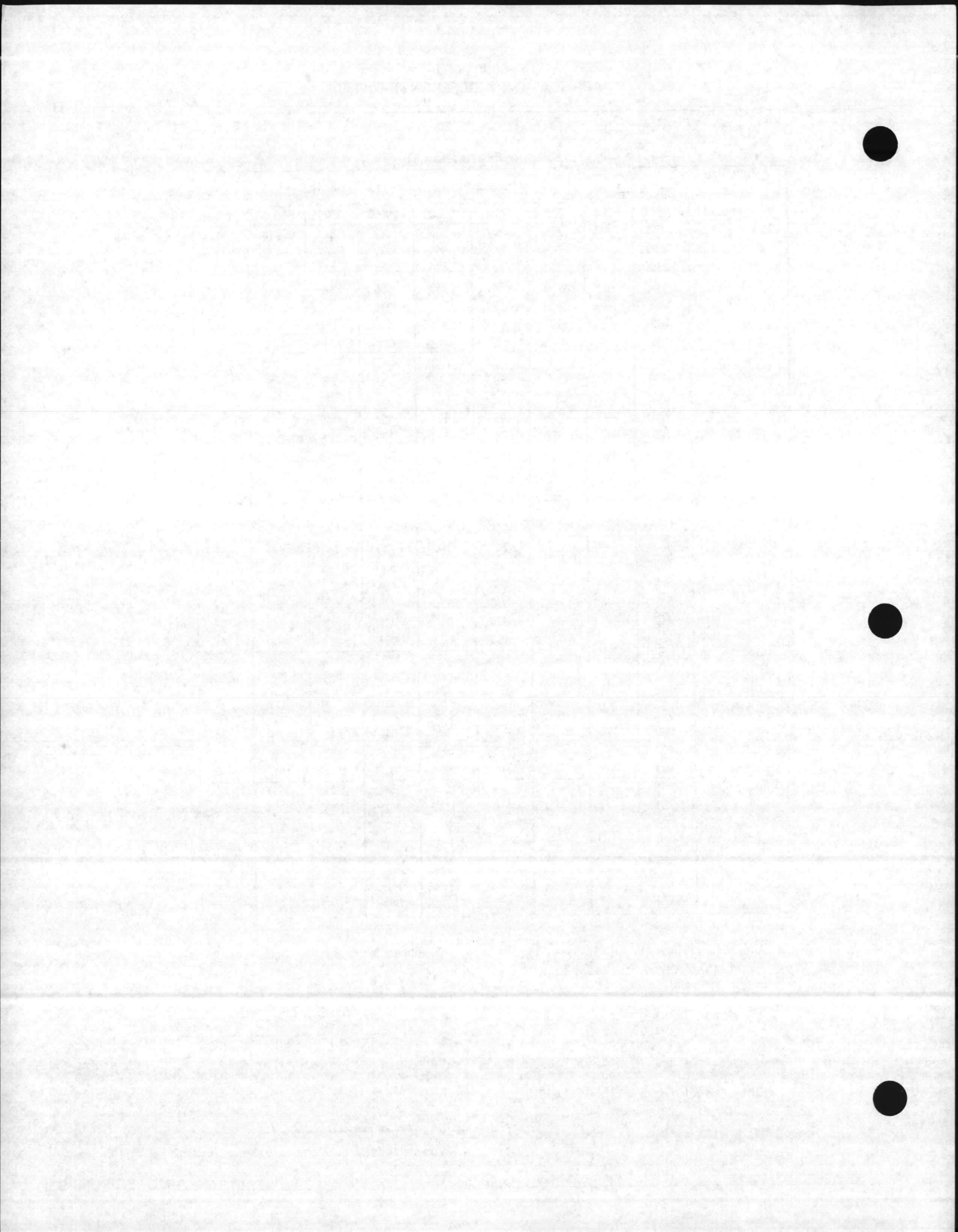



6900/7000  
APPLICATION & REFERENCE DATA

LINESHAFT RATING CHART

Shaft Size and Weight per Ft.	Speed (RPM)	Allowable Brake Horsepower at Thrust (lbs.) of:							
		3000	5000	7500	10000	20000	30000	50000	65000
3 <sup>11/16</sup>  K <sub>S</sub> = 36.3	1170	—	—	—	1971	1966	1957	1926	—
	880	—	—	—	1465	1462	1455	1432	—
	705	—	—	—	1187	1185	1175	1161	—
	585	—	—	—	985	983	978	963	—
	505	—	—	—	850	848	844	831	—
	440	—	—	—	741	739	736	724	—
	100	—	—	—	168.5	168.1	167.3	164.7	—
4  K <sub>S</sub> = 42.7	880	—	—	—	1531	1529	1524	1505	1485
	705	—	—	—	1240	1239	1235	1219	1203
	585	—	—	—	1029	1028	1024	1012	998
	505	—	—	—	888	887	884	873	862
	440	—	—	—	774	773	770	761	751
	100	—	—	—	176.0	175.8	175.2	173.0	170.7

Size	RPM	20000	30000	50000	65000	85000	105000	125000	150000
4 <sup>1/2</sup>  K <sub>S</sub> = 59.0	880	2137	2132	2116	2098	2067	—	—	—
	705	1732	1727	1715	1700	1675	—	—	—
	585	1437	1433	1423	1411	1390	—	—	—
	505	1240	1237	1228	1218	1200	—	—	—
	440	1081	1078	1070	1061	1045	—	—	—
	100	245.7	245.1	243.3	241.2	237.7	—	—	—
	5  K <sub>S</sub> = 73.0	880	—	2924	2910	2894	2866	2831	—
705		—	2370	2358	2345	2323	2294	—	—
585		—	1966	1956	1946	1927	1904	—	—
505		—	1697	1689	1680	1664	1643	—	—
440		—	1479	1471	1463	1449	1432	—	—
100		—	336.2	334.5	332.7	329.5	325.5	—	—
5 <sup>1/2</sup>  K <sub>S</sub> = 80.8		880	—	3941	3928	3915	3889	3858	3819
	705	—	3194	3183	3172	3152	3126	3094	—
	585	—	2650	2641	2632	2615	2594	2568	—
	505	—	2288	2280	2272	2257	2239	2216	—
	440	—	1993	1987	1980	1967	1951	1931	—
	100	—	453.1	451.6	450.0	447.1	443.5	439.0	—
	6  K <sub>S</sub> = 96.1	880	—	4930	4918	4905	4882	4852	4817
705		—	3995	3985	3974	3956	3932	3903	3859
585		—	3315	3307	3298	3283	3263	3239	3202
505		—	2861	2854	2847	2834	2816	2796	2764
440		—	2493	2487	2480	2469	2454	2436	2409
100		—	566.7	565.3	563.8	561.2	557.8	553.7	547.5

1. Above chart is based on AISI-1045 material.
2. For ratings other than those shown above use the following formula:

$$\text{BHP (Allowed)} = \frac{\text{RPM}}{100} \times \text{BHP @ 100 RPM}$$

Example: 1<sup>11/16</sup>" shaft @ 2300 RPM, 5000 lbs. Thrust

$$\text{BHP (Allowed)} = \frac{2300}{100} \times 17.0 = 391.0 \text{ HP}$$

3. Multipliers for various shaft materials.

Type	Multipliers	
	1"-2 <sup>3/16</sup> "	2 <sup>7/16</sup> " & Larger
416	1.1	1.2
304/316	.6	.6
17-4PH	1.6	1.7
Monel	.8	.8
K-Monel	1.6	1.7

4. 4" diameter lineshaft & larger use sleeve couplings.

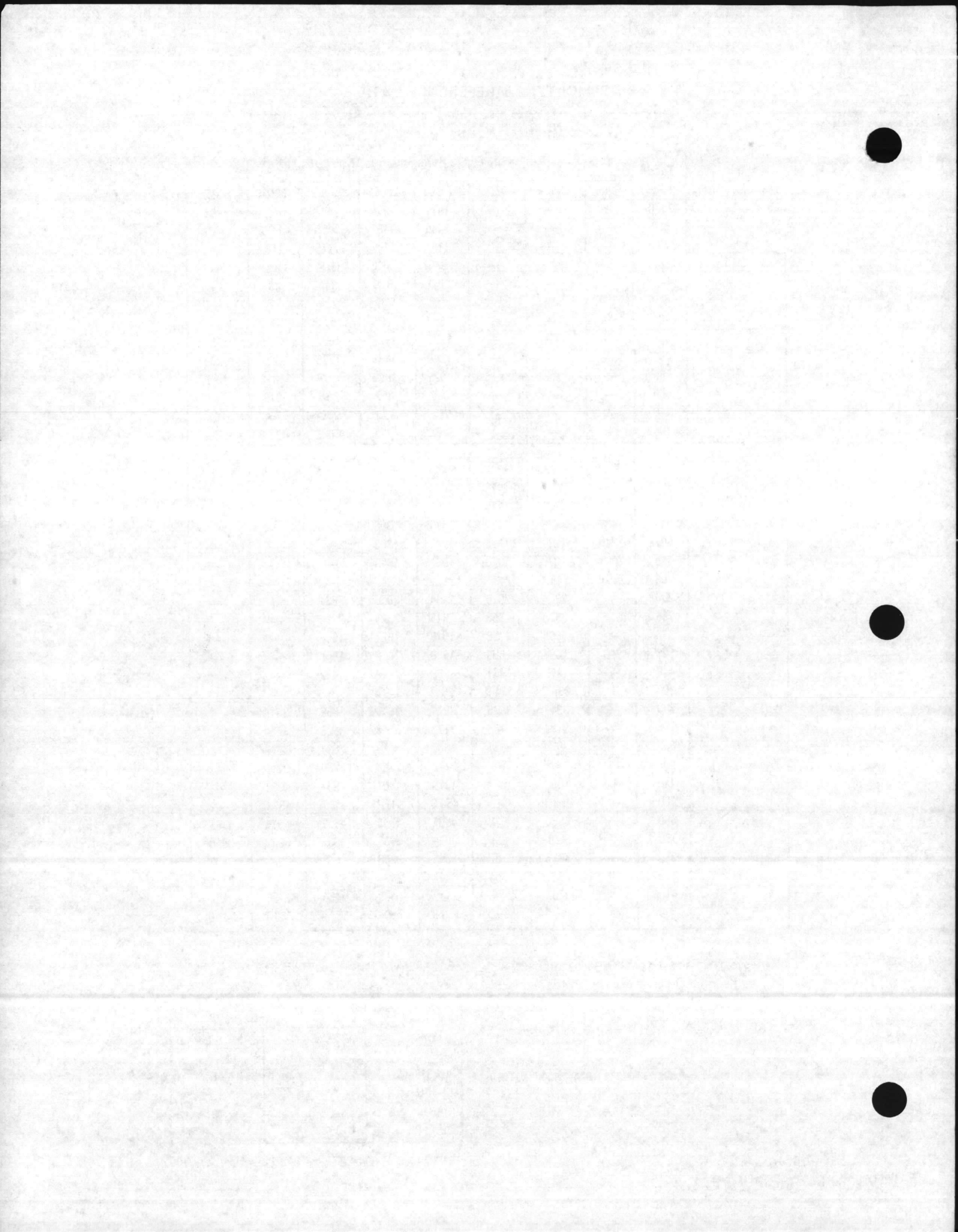

6900/7000  
APPLICATION & REFERENCE DATA

**STRETCH CONSTANTS**  
Open Lineshaft — AWWA Column

Pump	Col	Shaft	K	K'	Pump	Col	Shaft	K	K'
6M	4	1	4.5315	2.0161	12L	6	1	26.4782	2.6019
6M	4	1 1/4	1.5825	2.0161	12L	6	1 1/4	15.5046	2.6019
7M	4	1	9.7411	2.0161	12L	6	1 1/2	9.6368	2.6019
7M	4	1 1/4	5.2887	2.0161	12L	6	1 11/16	6.9097	2.6019
8M	4	1	8.2163	2.0161	12L	6	1 5/16	4.5120	2.6019
8M	4	1 1/4	4.2040	2.0161	12L	8	1	22.1803	3.5401
8M	5	1	6.2259	2.3387	12L	8	1 1/4	11.1749	3.5401
8M	5	1 1/4	2.1503	2.3387	12L	8	1 1/2	5.2682	3.5401
8M	5	1 1/2	0.0574	2.3387	12L	8	1 11/16	2.5075	3.5401
8M	6	1	4.7502	2.6019	12L	8	1 5/16	0.0586	3.5401
8M	6	1 1/4	0.6337	2.6019	12M	6	1	28.0466	2.6019
8M	6	1 1/2	-1.5092	2.6019	12M	6	1 1/4	16.5781	2.6019
10M	4	1	17.6190	2.0161	12M	6	1 1/2	10.4414	2.6019
10M	4	1 1/4	10.8931	2.0161	12M	6	1 11/16	7.5863	2.6019
10M	5	1	15.1402	2.3387	12M	6	1 5/16	5.0720	2.6019
10M	5	1 1/4	8.3511	2.3387	12M	8	1	23.7041	3.5401
10M	5	1 1/2	4.7842	2.3387	12M	8	1 1/4	12.2036	3.5401
10M	6	1	13.3484	2.6019	12M	8	1 1/2	6.0281	3.5401
10M	6	1 1/4	6.5184	2.6019	12M	8	1 11/16	3.1393	3.5401
10M	6	1 1/2	2.9015	2.6019	12M	8	1 5/16	0.5737	3.5401
10M	6	1 11/16	1.2456	2.6019	12H	6	1	40.3051	2.6019
10XH	6	1	39.6079	2.6019	12H	6	1 1/4	24.9678	2.6019
10XH	6	1 1/4	24.4907	2.6019	12H	6	1 1/2	16.7297	2.6019
10XH	6	1 1/2	16.3720	2.6019	12H	6	1 11/16	12.8744	2.6019
10XH	6	1 11/16	12.5737	2.6019	12H	6	1 5/16	9.4483	2.6019
10XH	8	1	34.9348	3.5401	12H	8	1	35.6120	3.5401
10XH	8	1 1/4	19.7857	3.5401	12H	8	1 1/4	20.2430	3.5401
10XH	8	1 1/2	11.6282	3.5401	12H	8	1 1/2	11.9659	3.5401
10XH	8	1 11/16	7.7962	3.5401	12H	8	1 11/16	8.0770	3.5401
10XHH	6	1	50.2977	2.6019	12H	8	1 5/16	4.5997	3.5401
10XHH	6	1 1/4	31.8069	2.6019	12XH	8	1	55.8160	3.5401
10XHH	6	1 1/2	21.8556	2.6019	12XH	8	1 1/4	33.8831	3.5401
10XHH	6	1 11/16	17.1851	2.6019	12XH	8	1 1/2	22.0406	3.5401
10XHH	6	1 5/16	13.0157	2.6019	12XH	8	1 11/16	16.4548	3.5401
10XHH	8	1	45.3189	3.5401	12XH	8	1 5/16	11.4304	3.5401
10XHH	8	1 1/4	26.7963	3.5401	12XH	10	1	51.1963	4.4683
10XHH	8	1 1/2	16.8063	3.5401	12XH	10	1 1/4	29.2415	4.4683
10XHH	8	1 11/16	12.1021	3.5401	12XH	10	1 1/2	17.3721	4.4683
10XHH	8	1 5/16	7.8815	3.5401	12XH	10	1 11/16	11.7629	4.4683
11M	6	1	20.4362	2.6019	12XH	10	1 5/16	6.7032	4.4683
11M	6	1 1/4	11.3694	2.6019	13H	8	1	55.8160	3.5401
11M	6	1 1/2	6.5374	2.6019	13H	8	1 1/4	33.8831	3.5401
11M	6	1 11/16	4.3032	2.6019	13H	8	1 1/2	22.0406	3.5401
11M	8	1	16.3110	3.5401	13H	8	1 11/16	16.4548	3.5401
11M	8	1 1/4	7.2124	3.5401	13H	8	1 5/16	11.4304	3.5401
11M	8	1 1/2	2.3415	3.5401	13H	10	1	51.1963	4.4683
11M	8	1 11/16	0.0737	3.5401	13H	10	1 1/4	29.2415	4.4683
11H	6	1	41.8737	2.6019	13H	10	1 1/2	17.3721	4.4683
11H	6	1 1/4	26.0414	2.6019	13H	10	1 11/16	11.7629	4.4683
11H	6	1 1/2	17.5343	2.6019	13H	10	1 5/16	6.7032	4.4683
11H	6	1 11/16	13.5511	2.6019					
11H	8	1	37.1358	3.5401					
11H	8	1 1/4	21.2717	3.5401					
11H	8	1 1/2	12.7257	3.5401					
11H	8	1 11/16	8.7089	3.5401					

$$\text{Stretch} = \frac{L(HK + 2HK' - LK')}{10,000,000} \times \text{S.G.}$$

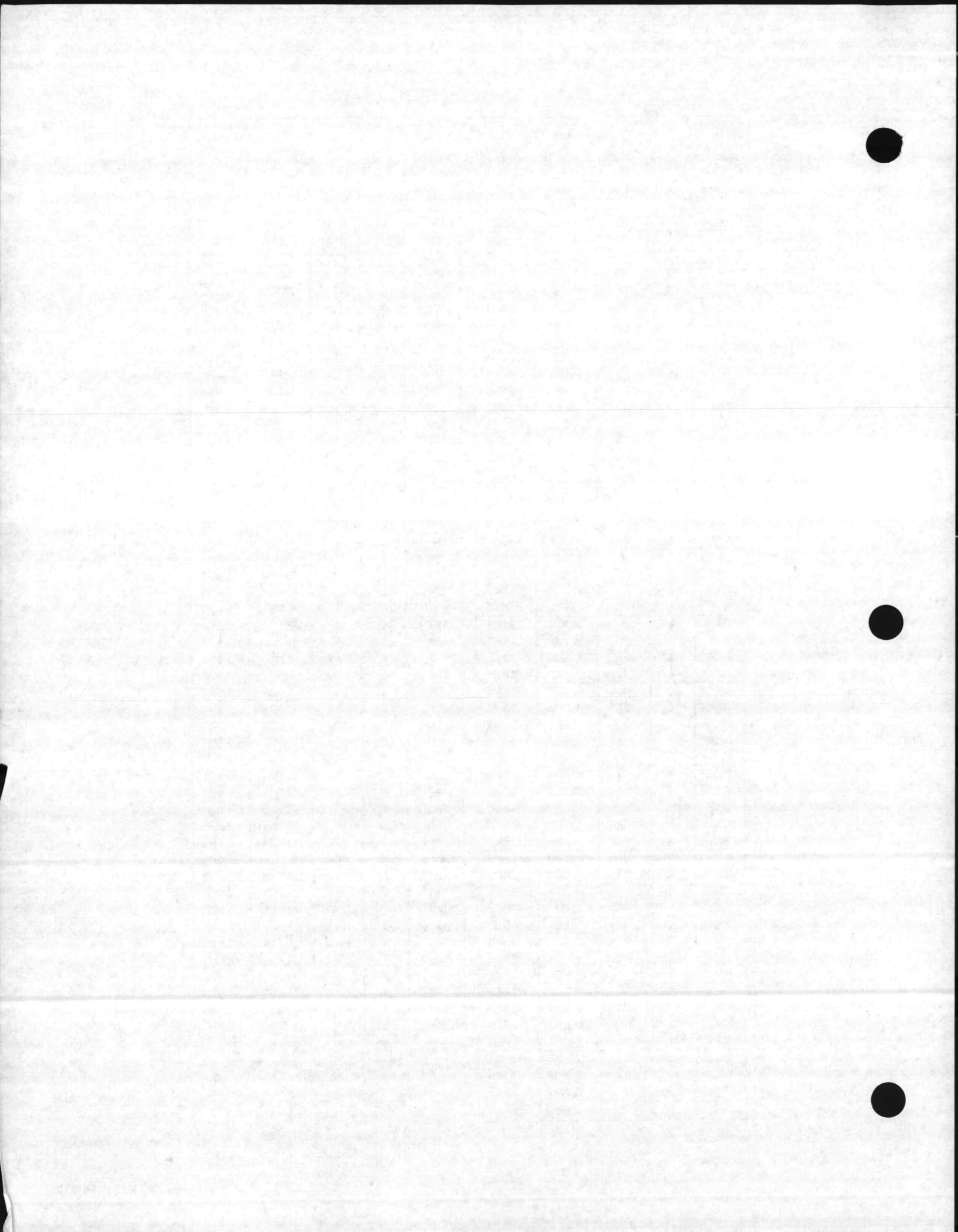

6900/7000  
APPLICATION & REFERENCE DATA

**STRETCH CONSTANTS**  
Open Lineshaft — AWWA Column

Pump	Col	Shaft	K	K'	Pump	Col	Shaft	K	K'
14M	8	1	35.4427	3.5401	17M	12	1 1/4	59.9699	4.4816
14M	8	1 1/4	20.1287	3.5401	17M	12	1 1/2	39.0479	4.4816
14M	8	1 1/2	11.8815	3.5401	17M	12	1 11/16	29.1189	4.4816
14M	8	1 11/16	8.0068	3.5401	17M	12	1 15/16	20.1055	4.4816
14M	8	1 15/16	4.5424	3.5401	17M	12	2 3/16	14.0465	4.4816
14M	8	2 3/16	2.2749	3.5401	17M	14	1 1/4	59.2060	4.3180
14M	10	1	31.2374	4.4683	17M	14	1 1/2	38.2695	4.3180
14M	10	1 1/4	15.9014	4.4683	17M	14	1 11/16	28.3281	4.3180
14M	10	1 1/2	7.6273	4.4683	17M	14	1 15/16	19.2958	4.3180
14M	10	1 11/16	3.7294	4.4683	17M	14	2 3/16	13.2152	4.3180
14M	10	1 15/16	0.2296	4.4683	17H	12	1 1/4	50.9018	4.4816
14M	10	2 3/16	-2.0782	4.4683	17H	12	1 1/2	32.5094	4.4816
14XH	10	1	83.9820	4.4683	17H	12	1 11/16	23.7844	4.4816
14XH	10	1 1/4	51.1547	4.4683	17H	12	1 15/16	15.8686	4.4816
14XH	10	1 1/2	33.3793	4.4683	17H	12	2 3/16	10.5528	4.4816
14XH	10	1 11/16	24.9594	4.4683	17H	14	1 1/4	50.2939	4.3180
14XH	10	1 15/16	17.3371	4.4683	17H	14	1 1/2	31.8872	4.3180
14XH	10	2 3/16	12.2379	4.4683	17H	14	1 11/16	23.1497	4.3180
14XH	12	1	81.6466	4.4816	17H	14	1 15/16	15.2150	4.3180
14XH	12	1 1/4	48.7954	4.4816	17H	14	2 3/16	9.8776	4.3180
14XH	12	1 1/2	30.9906	4.4816	21H	14	1 1/2	56.8889	4.3180
14XH	12	1 11/16	22.5453	4.4816	21H	14	1 11/16	43.4351	4.3180
14XH	12	1 15/16	14.8845	4.4816	21H	14	1 15/16	31.2007	4.3180
14XH	12	2 3/16	9.7413	4.4816	21H	14	2 3/16	22.9520	4.3180
15H	10	1	64.7418	4.4683	21H	14	2 7/16	17.1452	4.3180
15H	10	1 1/4	38.2950	4.4683	21H	16	1 1/2	53.6461	4.9878
15H	10	1 1/2	23.9855	4.4683	21H	16	1 11/16	40.1859	4.9878
15H	10	1 11/16	17.2151	4.4683	21H	16	1 15/16	27.9416	4.9878
15H	10	1 15/16	11.0966	4.4683	21H	16	2 3/16	19.6818	4.9878
15H	10	2 3/16	7.0158	4.4683	21H	16	2 7/16	13.8624	4.9878
15H	12	1	62.8420	4.4816	$\text{Stretch} = \frac{L(HK + 2HK' - LK') \times \text{S.G.}}{10,000,000}$				
15H	12	1 1/4	36.3713	4.4816					
15H	12	1 1/2	22.0325	4.4816					
15H	12	1 11/16	15.2367	4.4816					
15H	12	1 15/16	9.0796	4.4816					
15H	12	2 3/16	4.9547	4.4816					

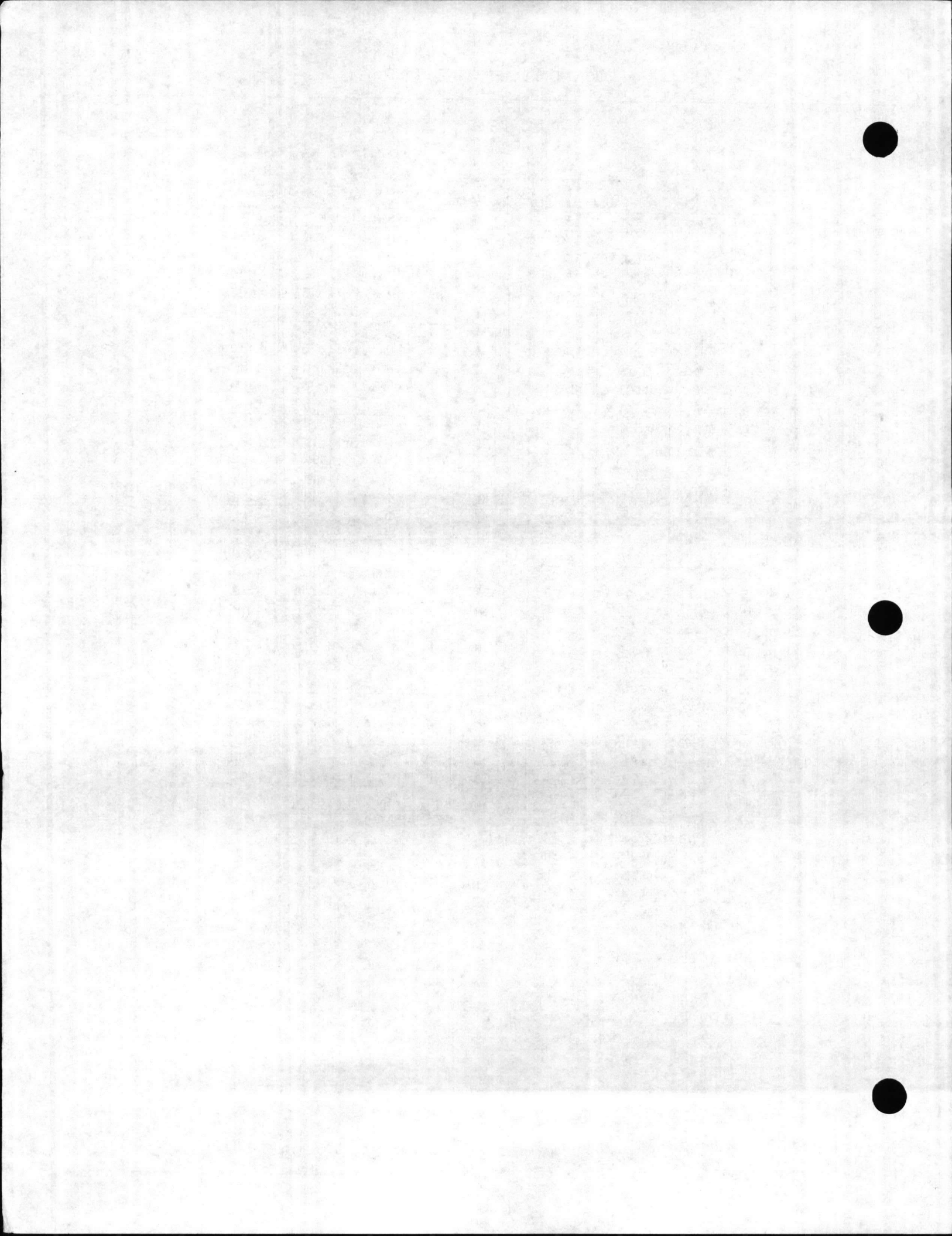

6900/7000  
APPLICATION & REFERENCE DATA

**STRETCH CONSTANTS**  
Open Lineshaft — 0.250" Wall Column

Pump	Col	Shaft	K	K'	Pump	Col	Shaft	K	K'
8M	6	1	3.7407	2.9581	12L	6	1	25.7762	2.9581
8M	6	1 1/4	-0.3600	2.9581	12L	6	1 1/4	14.8183	2.9581
8M	6	1 1/2	-2.4837	2.9581	12L	6	1 1/2	8.9698	2.9581
10M	6	1	12.4606	2.9581	12L	6	1 11/16	6.2594	2.9581
10M	6	1 1/4	5.6464	2.9581	12L	6	1 5/16	3.8870	2.9581
10M	6	1 1/2	2.0487	2.9581	12L	8	1	21.0925	3.9623
10M	6	1 11/16	0.4095	2.9581	12L	8	1 1/4	10.0981	3.9623
10XH	6	1	39.0918	2.9581	12L	8	1 1/2	4.2049	3.9623
10XH	6	1 1/4	23.9903	2.9581	12L	8	1 11/16	1.4558	3.9623
10XH	6	1 1/2	15.8909	2.9581	12L	8	1 5/16	-0.9753	3.9623
10XH	6	1 11/16	12.1092	2.9581	12M	6	1	27.3670	2.9581
10XH	8	1	33.9770	3.9623	12M	6	1 1/4	15.9141	2.9581
10XH	8	1 1/4	18.8389	3.9623	12M	6	1 1/2	9.7966	2.9581
10XH	8	1 1/2	10.6949	3.9623	12M	6	1 11/16	6.9582	2.9581
10XH	8	1 11/16	6.8745	3.9623	12M	6	1 5/16	4.4692	2.9581
10XHH	6	1	49.9328	2.9581	12M	8	1	22.6318	3.9623
10XHH	6	1 1/4	31.4577	2.9581	12M	8	1 1/4	11.1424	3.9623
10XHH	6	1 1/2	21.5258	2.9581	12M	8	1 1/2	4.9803	3.9623
10XHH	6	1 11/16	16.8719	2.9581	12M	8	1 11/16	2.1032	3.9623
10XHH	6	1 5/16	12.7279	2.9581	12M	8	1 5/16	-0.4446	3.9623
10XHH	8	1	44.4669	3.9623	12H	6	1	39.7988	2.9581
10XHH	8	1 1/4	25.9553	3.9623	12H	6	1 1/4	24.4773	2.9581
10XHH	8	1 1/2	15.9787	3.9623	12H	6	1 1/2	16.2584	2.9581
10XHH	8	1 11/16	11.2862	3.9623	12H	6	1 11/16	12.4198	2.9581
10XHH	8	1 5/16	7.0833	3.9623	12H	6	1 5/16	9.0190	2.9581
11M	6	1	19.6487	2.9581	12H	8	1	34.6611	3.9623
11M	6	1 1/4	10.5976	2.9581	12H	8	1 1/4	19.3031	3.9623
11M	6	1 1/2	5.7848	2.9581	12H	8	1 1/2	11.0395	3.9623
11M	6	1 11/16	3.5674	2.9581	12H	8	1 11/16	7.1622	3.9623
11M	8	1	15.1634	3.9623	12H	8	1 5/16	3.7026	3.9623
11M	8	1 1/4	6.0758	3.9623	12XH	8	1	55.0709	3.9623
11M	8	1 1/2	1.2184	3.9623	12XH	8	1 1/4	33.1491	3.9623
11M	8	1 11/16	-1.0377	3.9623	12XH	8	1 1/2	21.3200	3.9623
11H	6	1	41.3896	2.9581	12XH	8	1 11/16	15.7458	3.9623
11H	6	1 1/4	25.5731	2.9581	12XH	8	1 5/16	10.7392	3.9623
11H	6	1 1/2	17.0852	2.9581	12XH	10	1	49.8690	5.0297
11H	6	1 11/16	13.1187	2.9581	12XH	10	1 1/4	27.9236	5.0297
11H	8	1	36.2004	3.9623	12XH	10	1 1/2	16.0657	5.0297
11H	8	1 1/4	20.3473	3.9623	12XH	10	1 11/16	10.4666	5.0297
11H	8	1 1/2	11.8148	3.9623	12XH	10	1 5/16	5.4220	5.0297
11H	8	1 11/16	7.8096	3.9623	13H	8	1	55.0709	3.9623
					13H	8	1 1/4	33.1491	3.9623
					13H	8	1 1/2	21.3200	3.9623
					13H	8	1 11/16	15.7458	3.9623
					13H	8	1 5/16	10.7392	3.9623
					13H	10	1	49.8690	5.0297
					13H	10	1 1/4	27.9236	5.0297
					13H	10	1 1/2	16.0657	5.0297
					13H	10	1 11/16	10.4666	5.0297
					13H	10	1 5/16	5.4220	5.0297

$$\text{Stretch} = \frac{L(HK + 2HK' - LK') \times S.G.}{10,000,000}$$





6900/7000  
APPLICATION & REFERENCE DATA

**STRETCH CONSTANTS**  
Open Lineshaft — 0.250" Wall Column

Pump	Col	Shaft	K	K'	Pump	Col	Shaft	K	K'
8M	6	1	3.7407	2.9581	12L	6	1	25.7762	2.9581
8M	6	1 1/4	-0.3600	2.9581	12L	6	1 1/4	14.8183	2.9581
8M	6	1 1/2	-2.4837	2.9581	12L	6	1 1/2	8.9698	2.9581
10M	6	1	12.4606	2.9581	12L	6	1 1/16	6.2594	2.9581
10M	6	1 1/4	5.6464	2.9581	12L	6	1 5/16	3.8870	2.9581
10M	6	1 1/2	2.0487	2.9581	12L	8	1	21.0925	3.9623
10M	6	1 1/16	0.4095	2.9581	12L	8	1 1/4	10.0981	3.9623
10XH	6	1	39.0918	2.9581	12L	8	1 1/2	4.2049	3.9623
10XH	6	1 1/4	23.9903	2.9581	12L	8	1 1/16	1.4558	3.9623
10XH	6	1 1/2	15.8909	2.9581	12L	8	1 5/16	-0.9753	3.9623
10XH	6	1 1/16	12.1092	2.9581	12M	6	1	27.3670	2.9581
10XH	8	1	33.9770	3.9623	12M	6	1 1/4	15.9141	2.9581
10XH	8	1 1/4	18.8389	3.9623	12M	6	1 1/2	9.7966	2.9581
10XH	8	1 1/2	10.6949	3.9623	12M	6	1 1/16	6.9582	2.9581
10XH	8	1 1/16	6.8745	3.9623	12M	6	1 5/16	4.4692	2.9581
10XHH	6	1	49.9328	2.9581	12M	8	1	22.6318	3.9623
10XHH	6	1 1/4	31.4577	2.9581	12M	8	1 1/4	11.1424	3.9623
10XHH	6	1 1/2	21.5258	2.9581	12M	8	1 1/2	4.9803	3.9623
10XHH	6	1 1/16	16.8719	2.9581	12M	8	1 1/16	2.1032	3.9623
10XHH	6	1 5/16	12.7279	2.9581	12M	8	1 5/16	-0.4446	3.9623
10XHH	8	1	44.4669	3.9623	12H	6	1	39.7988	2.9581
10XHH	8	1 1/4	25.9553	3.9623	12H	6	1 1/4	24.4773	2.9581
10XHH	8	1 1/2	15.9787	3.9623	12H	6	1 1/2	16.2584	2.9581
10XHH	8	1 1/16	11.2862	3.9623	12H	6	1 1/16	12.4198	2.9581
10XHH	8	1 5/16	7.0833	3.9623	12H	6	1 5/16	9.0190	2.9581
11M	6	1	19.6487	2.9581	12H	8	1	34.6611	3.9623
11M	6	1 1/4	10.5976	2.9581	12H	8	1 1/4	19.3031	3.9623
11M	6	1 1/2	5.7848	2.9581	12H	8	1 1/2	11.0395	3.9623
11M	6	1 1/16	3.5674	2.9581	12H	8	1 1/16	7.1622	3.9623
11M	8	1	15.1634	3.9623	12H	8	1 5/16	3.7026	3.9623
11M	8	1 1/4	6.0758	3.9623	12XH	8	1	55.0709	3.9623
11M	8	1 1/2	1.2184	3.9623	12XH	8	1 1/4	33.1491	3.9623
11M	8	1 1/16	-1.0377	3.9623	12XH	8	1 1/2	21.3200	3.9623
11H	6	1	41.3896	2.9581	12XH	8	1 1/16	15.7458	3.9623
11H	6	1 1/4	25.5731	2.9581	12XH	8	1 5/16	10.7392	3.9623
11H	6	1 1/2	17.0852	2.9581	12XH	10	1	49.8690	5.0297
11H	6	1 1/16	13.1187	2.9581	12XH	10	1 1/4	27.9236	5.0297
11H	8	1	36.2004	3.9623	12XH	10	1 1/2	16.0657	5.0297
11H	8	1 1/4	20.3473	3.9623	12XH	10	1 1/16	10.4666	5.0297
11H	8	1 1/2	11.8148	3.9623	12XH	10	1 5/16	5.4220	5.0297
11H	8	1 1/16	7.8096	3.9623	13H	8	1	55.0709	3.9623
					13H	8	1 1/4	33.1491	3.9623
					13H	8	1 1/2	21.3200	3.9623
					13H	8	1 1/16	15.7458	3.9623
					13H	8	1 5/16	10.7392	3.9623
					13H	10	1	49.8690	5.0297
					13H	10	1 1/4	27.9236	5.0297
					13H	10	1 1/2	16.0657	5.0297
					13H	10	1 1/16	10.4666	5.0297
					13H	10	1 5/16	5.4220	5.0297

$$\text{Stretch} = \frac{L(HK + 2HK' - LK') \times \text{S.G.}}{10,000,000}$$



6900/7000  
APPLICATION & REFERENCE DATA

**STRETCH CONSTANTS**  
Open Lineshaft — 0.250" Wall Column

Pump	Col	Shaft	K	K'
14M	8	1	34.4900	3.9623
14M	8	1 <sup>1</sup> / <sub>4</sub>	19.1870	3.9623
14M	8	1 <sup>1</sup> / <sub>2</sub>	10.9533	3.9623
14M	8	1 <sup>11</sup> / <sub>16</sub>	7.0903	3.9623
14M	8	1 <sup>15</sup> / <sub>16</sub>	3.6436	3.9623
14M	8	2 <sup>3</sup> / <sub>16</sub>	1.3963	3.9623
14M	10	1	29.7324	5.0297
14M	10	1 <sup>1</sup> / <sub>4</sub>	14.4058	5.0297
14M	10	1 <sup>1</sup> / <sub>2</sub>	6.1433	5.0297
14M	10	1 <sup>11</sup> / <sub>16</sub>	2.2554	5.0297
14M	10	1 <sup>15</sup> / <sub>16</sub>	-1.2292	5.0297
14M	10	2 <sup>3</sup> / <sub>16</sub>	-3.5198	5.0297
14XH	10	1	82.9466	5.0297
14XH	10	1 <sup>1</sup> / <sub>4</sub>	50.1287	5.0297
14XH	10	1 <sup>1</sup> / <sub>2</sub>	32.3648	5.0297
14XH	10	1 <sup>11</sup> / <sub>16</sub>	23.9548	5.0297
14XH	10	1 <sup>15</sup> / <sub>16</sub>	16.3478	5.0297
14XH	10	2 <sup>3</sup> / <sub>16</sub>	11.2658	5.0297
14XH	12	1	78.0621	6.0345
14XH	12	1 <sup>1</sup> / <sub>4</sub>	45.2294	6.0345
14XH	12	1 <sup>1</sup> / <sub>2</sub>	27.4473	6.0345
14XH	12	1 <sup>11</sup> / <sub>16</sub>	19.0216	6.0345
14XH	12	1 <sup>15</sup> / <sub>16</sub>	11.3906	6.0345
14XH	12	2 <sup>3</sup> / <sub>16</sub>	6.2814	6.0345
15H	10	1	63.5351	5.0297
15H	10	1 <sup>1</sup> / <sub>4</sub>	37.0977	5.0297
15H	10	1 <sup>1</sup> / <sub>2</sub>	22.7997	5.0297
15H	10	1 <sup>11</sup> / <sub>16</sub>	16.0393	5.0297
15H	10	1 <sup>15</sup> / <sub>16</sub>	9.9360	5.0297
15H	10	2 <sup>3</sup> / <sub>16</sub>	5.8723	5.0297
15H	12	1	58.9207	6.0345
15H	12	1 <sup>1</sup> / <sub>4</sub>	32.4685	6.0345
15H	12	1 <sup>1</sup> / <sub>2</sub>	18.1523	6.0345
15H	12	1 <sup>11</sup> / <sub>16</sub>	11.3761	6.0345
15H	12	1 <sup>15</sup> / <sub>16</sub>	5.2489	6.0345
15H	12	2 <sup>3</sup> / <sub>16</sub>	1.1580	6.0345

Pump	Col	Shaft	K	K'
17M	12	1 <sup>1</sup> / <sub>4</sub>	56.7069	6.0345
17M	12	1 <sup>1</sup> / <sub>2</sub>	35.8075	6.0345
17M	12	1 <sup>11</sup> / <sub>16</sub>	25.8981	6.0345
17M	12	1 <sup>15</sup> / <sub>16</sub>	16.9146	6.0345
17M	12	2 <sup>3</sup> / <sub>16</sub>	10.8896	6.0345
17M	14	1 <sup>1</sup> / <sub>4</sub>	53.7405	6.6626
17M	14	1 <sup>1</sup> / <sub>2</sub>	32.8324	6.6626
17M	14	1 <sup>11</sup> / <sub>16</sub>	22.9156	6.6626
17M	14	1 <sup>15</sup> / <sub>16</sub>	13.9206	6.6626
17M	14	2 <sup>3</sup> / <sub>16</sub>	7.8826	6.6626
17H	12	1 <sup>1</sup> / <sub>4</sub>	47.3929	6.0345
17H	12	1 <sup>1</sup> / <sub>2</sub>	29.0232	6.0345
17H	12	1 <sup>11</sup> / <sub>16</sub>	20.3178	6.0345
17H	12	1 <sup>15</sup> / <sub>16</sub>	12.4319	6.0345
17H	12	2 <sup>3</sup> / <sub>16</sub>	7.1500	6.0345
17H	14	1 <sup>1</sup> / <sub>4</sub>	44.5206	6.6626
17H	14	1 <sup>1</sup> / <sub>2</sub>	26.1422	6.6626
17H	14	1 <sup>11</sup> / <sub>16</sub>	17.4293	6.6626
17H	14	1 <sup>15</sup> / <sub>16</sub>	9.5320	6.6626
17H	14	2 <sup>3</sup> / <sub>16</sub>	4.2372	6.6626
21H	14	1 <sup>1</sup> / <sub>2</sub>	52.3499	6.6626
21H	14	1 <sup>11</sup> / <sub>16</sub>	38.9207	6.6626
21H	14	1 <sup>15</sup> / <sub>16</sub>	26.7236	6.6626
21H	14	2 <sup>3</sup> / <sub>16</sub>	18.5175	6.6626
21H	14	2 <sup>7</sup> / <sub>16</sub>	12.7583	6.6626
21H	16	1 <sup>1</sup> / <sub>2</sub>	47.5082	7.6677
21H	16	1 <sup>11</sup> / <sub>16</sub>	34.0694	7.6677
21H	16	1 <sup>15</sup> / <sub>16</sub>	21.8579	7.6677
21H	16	2 <sup>3</sup> / <sub>16</sub>	13.6352	7.6677
21H	16	2 <sup>7</sup> / <sub>16</sub>	7.8576	7.6677

$$\text{Stretch} = \frac{L(HK + 2HK' - LK') \times \text{S.G.}}{10,000,000}$$

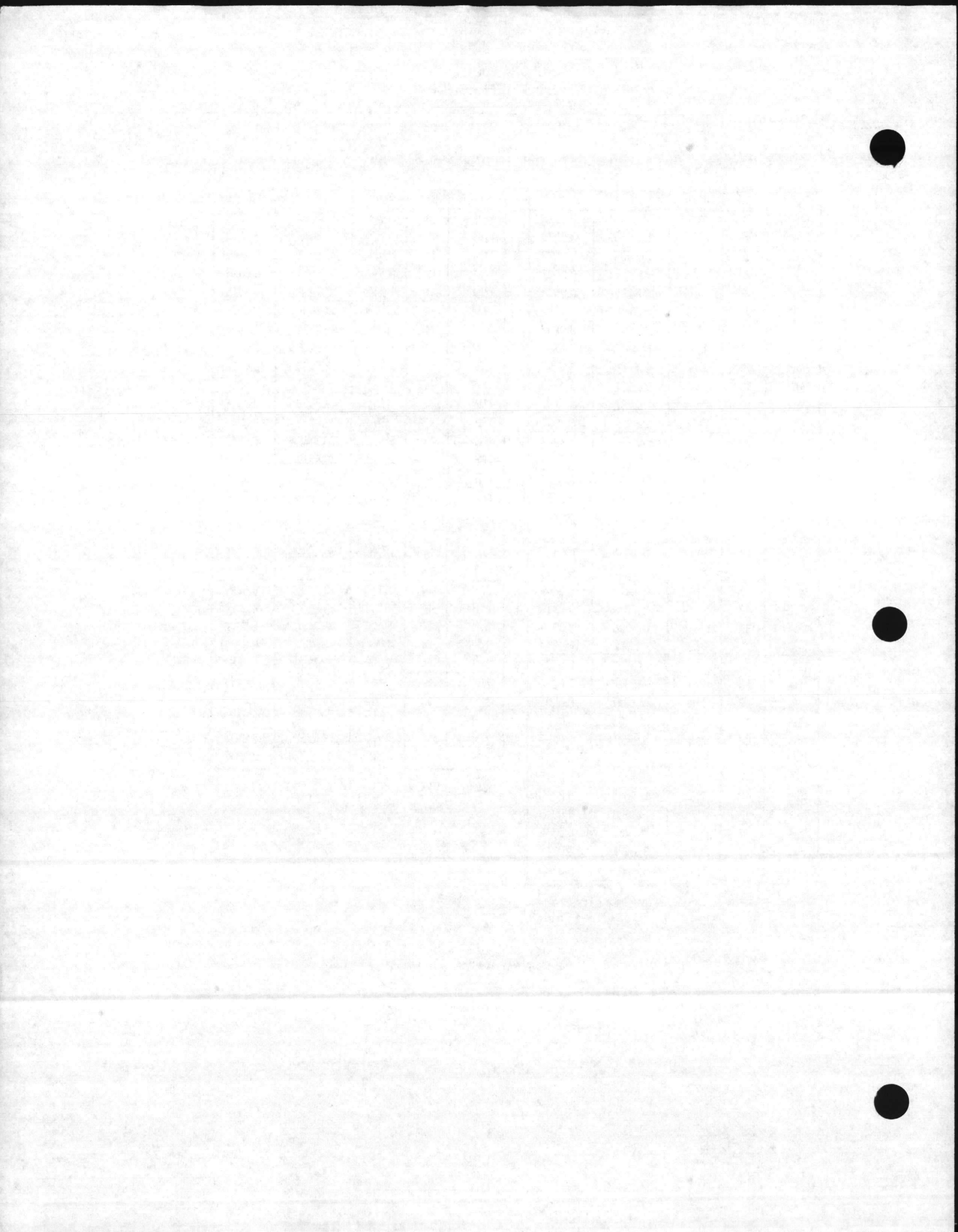

6900/7000  
APPLICATION & REFERENCE DATA

STRETCH CONSTANTS  
Enclosed Lineshaft — AWWA Column

Pump	Col	Shaft	Tube	K	K'	Pump	Col	Shaft	Tube	K	K'
6M	4	1	1½	6.4594	2.0161	12L	6	1	1½	27.7169	2.6019
6M	4	1¼	2	4.0748	2.0161	12L	6	1¼	2	17.1801	2.6019
7M	4	1	1½	11.4088	2.0161	12L	6	1½	2½	11.8556	2.6019
7M	4	1¼	2	7.4527	2.0161	12L	6	1½/16	2½	8.9832	2.6019
8M	4	1	1½	9.9602	2.0161	12L	6	1½/16	3	7.1605	2.6019
8M	4	1¼	2	6.4641	2.0161	12L	8	1	1½	23.7197	3.5401
8M	5	1	1½	8.0000	2.3387	12L	8	1¼	2	13.2595	3.5401
8M	5	1¼	2	4.4951	2.3387	12L	8	1½	2½	8.1290	3.5401
8M	5	1½	2½	3.0931	2.3387	12L	8	1½/16	2½	5.2565	3.5401
8M	6	1	1½	6.4195	2.6019	12L	8	1½/16	3	3.5799	3.5401
8M	6	1¼	2	2.8702	2.6019	12M	6	1	1½	29.2544	2.6019
8M	6	1½	2½	1.4806	2.6019	12M	6	1¼	2	18.2132	2.6019
10M	4	1	1½	18.8933	2.0161	12M	6	1½	2½	12.6046	2.6019
10M	4	1¼	2	12.5609	2.0161	12M	6	1½/16	2½	9.6042	2.6019
10M	5	1	1½	16.6405	2.3387	12M	6	1½/16	3	7.6526	2.6019
10M	5	1¼	2	10.3439	2.3387	12M	8	1	1½	25.2244	3.5401
10M	5	1½	2½	7.3465	2.3387	12M	8	1¼	2	14.2631	3.5401
10M	6	1	1½	14.8473	2.6019	12M	8	1½	2½	8.8536	3.5401
10M	6	1¼	2	8.5330	2.6019	12M	8	1½/16	2½	5.8532	3.5401
10M	6	1½	2½	5.5862	2.6019	12M	8	1½/16	3	4.0514	3.5401
10M	6	1½/16	2½	3.7850	2.6019	12H	6	1	1½	41.2699	2.6019
10XH	6	1	1½	40.5865	2.6019	12H	6	1¼	2	26.2864	2.6019
10XH	6	1¼	2	25.8273	2.6019	12H	6	1½	2½	18.4579	2.6019
10XH	6	1½	2½	18.1250	2.6019	12H	6	1½/16	2½	14.4573	2.6019
10XH	6	1½/16	2½	14.1813	2.6019	12H	6	1½/16	3	11.4984	2.6019
10XH	8	1	1½	36.3147	3.5401	12H	8	1	1½	36.9835	3.5401
10XH	8	1¼	2	21.6600	3.5401	12H	8	1¼	2	22.1061	3.5401
10XH	8	1½	2½	14.1944	3.5401	12H	8	1½	2½	14.5164	3.5401
10XH	8	1½/16	2½	10.2507	3.5401	12H	8	1½/16	2½	10.5158	3.5401
10XHH	6	1	1½	51.0644	2.6019	12H	8	1½/16	3	7.7365	3.5401
10XHH	6	1¼	2	32.8675	2.6019	12XH	8	1	1½	56.9348	3.5401
10XHH	6	1½	2½	23.2293	2.6019	12XH	8	1¼	2	35.4132	3.5401
10XHH	6	1½/16	2½	18.4134	2.6019	12XH	8	1½	2½	24.1244	3.5401
10XHH	6	1½/16	3	14.6334	2.6019	12XH	8	1½/16	2½	18.4269	3.5401
10XHH	8	1	1½	46.5690	3.5401	12XH	8	1½/16	3	13.9890	3.5401
10XHH	8	1¼	2	28.4994	3.5401	12XH	10	1	1½	52.5878	4.4683
10XHH	8	1½	2½	19.1325	3.5401	12XH	10	1¼	2	31.1403	4.4683
10XHH	8	1½/16	2½	14.3167	3.5401	12XH	10	1½	2½	20.0274	4.4683
10XHH	8	1½/16	3	10.7405	3.5401	12XH	10	1½/16	2½	14.3299	4.4683
11M	6	1	1½	21.7946	2.6019	12XH	10	1½/16	3	10.0295	4.4683
11M	6	1¼	2	13.2009	2.6019	13H	8	1	1½	56.9348	3.5401
11M	6	1½	2½	8.9706	2.6019	13H	8	1¼	2	35.4132	3.5401
11M	6	1½/16	2½	6.5911	2.6019	13H	8	1½	2½	24.1244	3.5401
11M	8	1	1½	17.9238	3.5401	13H	8	1½/16	2½	18.4269	3.5401
11M	8	1¼	2	9.3937	3.5401	13H	8	1½/16	3	13.9890	3.5401
11M	8	1½	2½	5.3379	3.5401	13H	10	1	1½	52.5878	4.4683
11M	8	1½/16	2½	2.9584	3.5401	13H	10	1¼	2	31.1403	4.4683
11H	6	1	1½	42.8074	2.6019	13H	10	1½	2½	20.0274	4.4683
11H	6	1¼	2	27.3195	2.6019	13H	10	1½/16	2½	14.3299	4.4683
11H	6	1½	2½	19.2069	2.6019	13H	10	1½/16	3	10.0295	4.4683
11H	6	1½/16	2½	15.0783	2.6019						
11H	8	1	1½	38.4882	3.5401						
11H	8	1¼	2	23.1097	3.5401						
11H	8	1½	2½	15.2410	3.5401						
11H	8	1½/16	2½	11.1125	3.5401						

$$\text{Stretch} = \frac{L(HK + 2HK' - LK') \times \text{S.G.}}{10,000,000}$$



6900/7000  
APPLICATION & REFERENCE DATA

**STRETCH CONSTANTS**  
Enclosed Lineshaft — AWWA Column

Pump	Col	Shaft	Tube	K	K'
14M	8	1	1 1/2	36.8163	3.5401
14M	8	1 1/4	2	21.9946	3.5401
14M	8	1 1/2	2 1/2	14.4359	3.5401
14M	8	1 11/16	2 1/2	10.4495	3.5401
14M	8	1 15/16	3	7.6841	3.5401
14M	8	2 3/16	3	5.2234	3.5401
14M	10	1	1 1/2	32.7929	4.4683
14M	10	1 1/4	2	18.0183	4.4683
14M	10	1 1/2	2 1/2	10.5929	4.4683
14M	10	1 11/16	2 1/2	6.6065	4.4683
14M	10	1 15/16	3	3.9451	4.4683
14M	10	2 3/16	3	1.4843	4.4683
14XH	10	1	1 1/2	85.1041	4.4683
14XH	10	1 1/4	2	52.6953	4.4683
14XH	10	1 1/2	2 1/2	35.5252	4.4683
14XH	10	1 11/16	2 1/2	27.0168	4.4683
14XH	10	1 15/16	3	20.0242	4.4683
14XH	10	2 3/16	3	14.7721	4.4683
14XH	12	1	1 1/2	82.6499	4.4816
14XH	12	1 1/4	2	50.1818	4.4816
14XH	12	1 1/2	2 1/2	32.9678	4.4816
14XH	12	1 11/16	2 1/2	24.4594	4.4816
14XH	12	1 15/16	3	17.4117	4.4816
14XH	12	2 3/16	3	12.1596	4.4816
15H	10	1	1 1/2	66.0220	4.4683
15H	10	1 1/4	2	40.0458	4.4683
15H	10	1 1/2	2 1/2	26.4304	4.4683
15H	10	1 11/16	2 1/2	19.5715	4.4683
15H	10	1 15/16	3	14.1589	4.4683
15H	10	2 3/16	3	9.9250	4.4683
15H	12	1	1 1/2	63.9282	4.4816
15H	12	1 1/4	2	37.8689	4.4816
15H	12	1 1/2	2 1/2	24.1706	4.4816
15H	12	1 11/16	2 1/2	17.3118	4.4816
15H	12	1 15/16	3	11.8120	4.4816
15H	12	2 3/16	3	7.5781	4.4816

Pump	Col	Shaft	Tube	K	K'
17M	12	1 1/4	2	61.2563	4.4816
17M	12	1 1/2	2 1/2	40.8801	4.4816
17M	12	1 11/16	2 1/2	30.8882	4.4816
17M	12	1 15/16	3	22.4482	4.4816
17M	12	2 3/16	3	16.2802	4.4816
17M	14	1 1/4	2	60.3237	4.3180
17M	14	1 1/2	2 1/2	39.8798	4.3180
17M	14	1 11/16	2 1/2	29.8878	4.3180
17M	14	1 15/16	3	21.3764	4.3180
17M	14	2 3/16	3	15.2084	4.3180
17H	12	1 1/4	2	52.2693	4.4816
17H	12	1 1/2	2 1/2	34.4592	4.4816
17H	12	1 11/16	2 1/2	25.6712	4.4816
17H	12	1 15/16	3	18.3611	4.4816
17H	12	2 3/16	3	12.9363	4.4816
17H	14	1 1/4	2	51.4650	4.3180
17H	14	1 1/2	2 1/2	33.5754	4.3180
17H	14	1 11/16	2 1/2	24.7874	4.3180
17H	14	1 15/16	3	17.3957	4.3180
17H	14	2 3/16	3	11.9710	4.3180
21H	14	1 1/2	2 1/2	58.2718	4.3180
21H	14	1 11/16	2 1/2	44.7675	4.3180
21H	14	1 15/16	3	32.9893	4.3180
21H	14	2 3/16	3	24.6532	4.3180
21H	14	2 7/16	3 1/2	19.1978	4.3180
21H	16	1 1/2	2 1/2	55.2251	4.9878
21H	16	1 11/16	2 1/2	41.7207	4.9878
21H	16	1 15/16	3	29.9923	4.9878
21H	16	2 3/16	3	21.6562	4.9878
21H	16	2 7/16	3 1/2	16.2428	4.9878

$$\text{Stretch} = \frac{L(HK + 2HK' - LK') \times \text{S.G.}}{10,000,000}$$





6900/7000  
APPLICATION & REFERENCE DATA

**STRETCH CONSTANTS**  
Enclosed Lineshaft — .0250" Wall Column

Pump	Col	Shaft	Tube	K	K'	Pump	Col	Shaft	Tube	K	K'
8M	6	1	1½	5.7453	2.9581	12L	6	1	1½	27.2555	2.9581
8M	6	1¼	2	2.3010	2.9581	12L	6	1¼	2	16.7987	2.9581
8M	6	1½	2½	1.0451	2.9581	12L	6	1½	2½	11.5712	2.9581
10M	6	1	1½	14.2574	2.9581	12L	6	1½/16	2½	8.6987	2.9581
10M	6	1¼	2	8.0381	2.9581	12L	6	1½/16	3	6.9601	2.9581
10M	6	1½	2½	5.2105	2.9581	12L	8	1	1½	22.9222	3.9623
10M	6	1½/16	2½	3.4093	2.9581	12L	8	1¼	2	12.5580	3.9623
10XH	6	1	1½	40.2537	2.9581	12L	8	1½	2½	7.5595	3.9623
10XH	6	1¼	2	25.5593	2.9581	12L	8	1½/16	2½	4.6871	3.9623
10XH	6	1½	2½	17.9319	2.9581	12L	8	1½/16	3	3.1231	3.9623
10XH	6	1½/16	2½	13.9882	2.9581	12M	6	1	1½	28.8084	2.9581
10XH	8	1	1½	35.6147	3.9623	12M	6	1¼	2	17.8453	2.9581
10XH	8	1¼	2	21.0467	3.9623	12M	6	1½	2½	12.3311	2.9581
10XH	8	1½	2½	13.6988	3.9623	12M	6	1½/16	2½	9.3307	2.9581
10XH	8	1½/16	2½	9.7551	3.9623	12M	6	1½/16	3	7.4612	2.9581
10XHH	6	1	1½	50.8362	2.9581	12M	8	1	1½	24.4386	3.9623
10XHH	6	1¼	2	32.6918	2.9581	12M	8	1¼	2	13.5721	3.9623
10XHH	6	1½	2½	23.1105	2.9581	12M	8	1½	2½	8.2930	3.9623
10XHH	6	1½/16	2½	18.2946	2.9581	12M	8	1½/16	2½	5.2925	3.9623
10XHH	6	1½/16	3	14.5696	2.9581	12M	8	1½/16	3	3.6022	3.9623
10XHH	8	1	1½	45.9483	3.9623	12H	6	1	1½	40.9438	2.9581
10XHH	8	1¼	2	27.9579	3.9623	12H	6	1¼	2	26.0245	2.9581
10XHH	8	1½	2½	18.6971	3.9623	12H	6	1½	2½	18.2696	2.9581
10XHH	8	1½/16	2½	13.8812	3.9623	12H	6	1½/16	2½	14.2691	2.9581
10XHH	8	1½/16	3	10.3980	3.9623	12H	6	1½/16	3	11.3773	2.9581
11M	6	1	1½	21.2741	2.9581	12H	8	1	1½	36.2886	3.9623
11M	6	1¼	2	12.7672	2.9581	12H	8	1¼	2	21.4974	3.9623
11M	6	1½	2½	8.6442	2.9581	12H	8	1½	2½	14.0247	3.9623
11M	6	1½/16	2½	6.2647	2.9581	12H	8	1½/16	2½	10.0242	3.9623
11M	8	1	1½	17.0815	3.9623	12H	8	1½/16	3	7.3461	3.9623
11M	8	1¼	2	8.6516	3.9623	12XH	8	1	1½	56.3943	3.9623
11M	8	1½	2½	4.7344	3.9623	12XH	8	1¼	2	34.9442	3.9623
11M	8	1½/16	2½	2.3549	3.9623	12XH	8	1½	2½	23.7497	3.9623
11H	6	1	1½	42.4967	2.9581	12XH	8	1½/16	2½	18.0522	3.9623
11H	6	1¼	2	27.0711	2.9581	12XH	8	1½/16	3	13.6983	3.9623
11H	6	1½	2½	19.0295	2.9581	12XH	10	1	1½	51.5518	5.0297
11H	6	1½/16	2½	14.9010	2.9581	12XH	10	1¼	2	30.2045	5.0297
11H	8	1	1½	37.8050	3.9623	12XH	10	1½	2½	19.2369	5.0297
11H	8	1¼	2	22.5116	3.9623	12XH	10	1½/16	2½	13.5394	5.0297
11H	8	1½	2½	14.7582	3.9623	12XH	10	1½/16	3	9.3664	5.0297
11H	8	1½/16	2½	10.6296	3.9623	13H	8	1	1½	56.3943	3.9623
						13H	8	1¼	2	34.9442	3.9623
						13H	8	1½	2½	23.7497	3.9623
						13H	8	1½/16	2½	18.0522	3.9623
						13H	8	1½/16	3	13.6983	3.9623
						13H	10	1	1½	51.5518	5.0297
						13H	10	1¼	2	30.2045	5.0297
						13H	10	1½	2½	19.2369	5.0297
						13H	10	1½/16	2½	13.5394	5.0297
						13H	10	1½/16	3	9.3664	5.0297

$$\text{Stretch} = \frac{L(HK + 2HK' - LK') \times \text{S.G.}}{10,000,000}$$



6900/7000  
APPLICATION & REFERENCE DATA

**STRETCH CONSTANTS**  
Enclosed Lineshaft — 0.250" Wall Column

Pump	Col	Shaft	Tube	K	K'
14M	8	1	1½	36.1201	3.9623
14M	8	1¼	2	21.3848	3.9623
14M	8	1½	2½	13.9433	3.9623
14M	8	1⅞	2½	9.9569	3.9623
14M	8	1⅝	3	7.2929	3.9623
14M	8	2⅜	3	4.8321	3.9623
14M	10	1	1½	31.6160	5.0297
14M	10	1¼	2	16.9527	5.0297
14M	10	1½	2½	9.6903	5.0297
14M	10	1⅞	2½	5.7040	5.0297
14M	10	1⅝	3	3.1841	5.0297
14M	10	2⅜	3	0.7233	5.0297
14XH	10	1	1½	84.2995	5.0297
14XH	10	1¼	2	51.9726	5.0297
14XH	10	1½	2½	34.9187	5.0297
14XH	10	1⅞	2½	26.4103	5.0297
14XH	10	1⅝	3	19.5220	5.0297
14XH	10	2⅜	3	14.2698	5.0297
14XH	12	1	1½	79.6991	6.0345
14XH	12	1¼	2	47.4576	6.0345
14XH	12	1½	2½	30.5869	6.0345
14XH	12	1⅞	2½	22.0786	6.0345
14XH	12	1⅝	3	15.3412	6.0345
14XH	12	2⅜	3	10.0891	6.0345
15H	10	1	1½	65.0816	5.0297
15H	10	1¼	2	39.1981	5.0297
15H	10	1½	2½	25.7159	5.0297
15H	10	1⅞	2½	18.8571	5.0297
15H	10	1⅝	3	13.5622	5.0297
15H	10	2⅜	3	9.3283	5.0297
15H	12	1	1½	60.6968	6.0345
15H	12	1¼	2	34.8822	6.0345
15H	12	1½	2½	21.5566	6.0345
15H	12	1⅞	2½	14.6978	6.0345
15H	12	1⅝	3	9.5328	6.0345
15H	12	2⅜	3	5.2989	6.0345
17M	12	1¼	2	58.7683	6.0345
17M	12	1½	2½	38.7090	6.0345
17M	12	1⅞	2½	28.7170	6.0345
17M	12	1⅝	3	20.5655	6.0345
17M	12	2⅜	3	14.3975	6.0345
17M	14	1¼	2	55.9941	6.6626
17M	14	1½	2½	36.0293	6.6626
17M	14	1⅞	2½	26.0374	6.6626
17M	14	1⅝	3	17.9657	6.6626
17M	14	2⅜	3	11.7977	6.6626
17H	12	1¼	2	49.5897	6.0345
17H	12	1½	2½	32.1179	6.0345
17H	12	1⅞	2½	23.3299	6.0345
17H	12	1⅝	3	16.3260	6.0345
17H	12	2⅜	3	10.9012	6.0345
17H	14	1¼	2	46.8874	6.6626
17H	14	1½	2½	29.5016	6.6626
17H	14	1⅞	2½	20.7136	6.6626
17H	14	1⅝	3	13.7824	6.6626
17H	14	2⅜	3	8.3577	6.6626
21H	14	1½	2½	55.0729	6.6626
21H	14	1⅞	2½	41.5686	6.6626
21H	14	1⅝	3	30.1696	6.6626
21H	14	2⅜	3	21.8334	6.6626
21H	14	2⅞	3½	16.6703	6.6626
21H	16	1½	2½	50.6849	7.6677
21H	16	1⅞	2½	37.1805	7.6677
21H	16	1⅝	3	25.9058	7.6677
21H	16	2⅜	3	17.5697	7.6677
21H	16	2⅞	3½	12.5099	7.6677

$$\text{Stretch} = \frac{L(HK + 2HK' - LK') \times \text{S.G.}}{10,000,000}$$

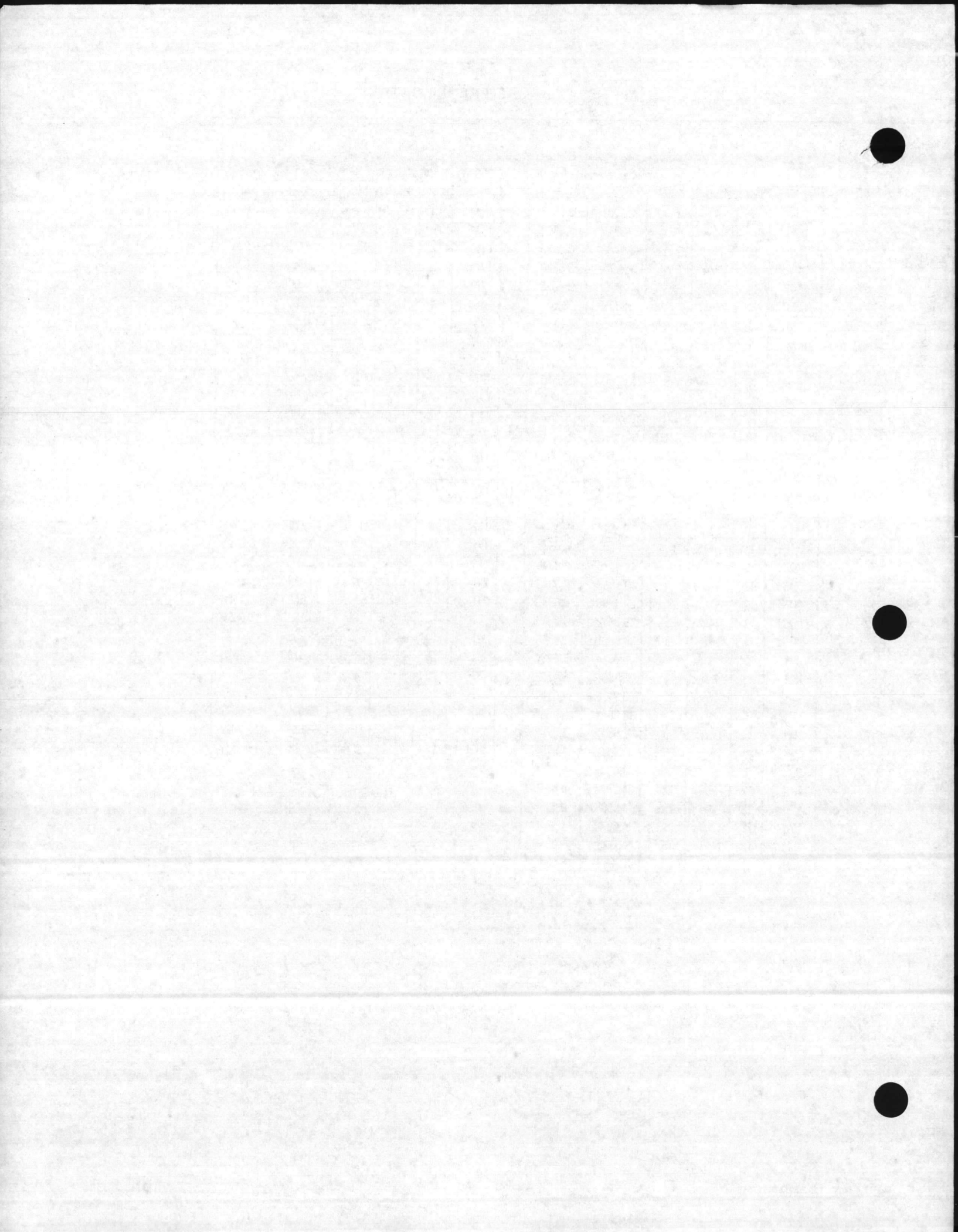

COLUMN FRICTION LOSS CHART

Column and Enclosing Tube Size	Column and Open Lineshaft Size	Friction Loss in Feet Per 100 Feet of Setting								
		0-900 GPM								
		100	200	300	400	500	600	700	800	900
4 x 1 1/2	4 x 1	2.90	4.60	9.00	14.50	—	—	—	—	—
4 x 2	4 x 1 1/4	5.30	9.20	21.80	—	—	—	—	—	—
6 x 1 1/2	6 x 1	—	.73	1.60	2.70	3.80	5.20	7.00	8.90	11.50
6 x 2	6 x 1 1/4	—	.95	2.00	3.40	4.90	7.00	9.00	12.00	14.50
6 x 2 1/2	6 x 1 1/2	—	1.40	2.90	4.70	6.90	9.50	12.50	16.20	—
	6 x 1 11/16	—	1.40	2.90	4.70	6.90	9.50	12.50	16.20	—
6 x 3	6 x 1 5/16	—	2.20	4.50	7.60	11.80	17.10	—	—	—
8 x 1 1/2	8 x 1	—	—	—	—	—	—	.98	1.30	1.60
8 x 2	8 x 1 1/4	—	—	—	.61	.91	1.30	1.80	2.20	2.80
8 x 2 1/2	8 x 1 1/2	—	—	—	.74	1.10	1.55	2.10	2.70	3.20
	8 x 1 11/16	—	—	—	.74	1.10	1.55	2.10	2.70	3.20
8 x 3	8 x 1 5/16	—	—	—	1.05	1.55	2.20	2.90	3.70	4.70
	8 x 2 3/16	—	—	—	1.05	1.55	2.20	2.90	3.70	4.70
10 x 1 1/2	10 x 1	—	—	—	—	—	—	—	—	—
10 x 2	10 x 1 1/4	—	—	—	—	—	—	—	.58	.72
10 x 2 1/2	10 x 1 1/2	—	—	—	—	—	—	.50	.67	.83
	10 x 1 11/16	—	—	—	—	—	—	.50	.67	.83
10 x 3	10 x 1 5/16	—	—	—	—	—	—	.62	.80	1.00
	10 x 2 3/16	—	—	—	—	—	—	.62	.80	1.00

COLUMN FRICTION LOSS CHART

Column and Enclosing Tube Size	Column and Open Lineshaft Size	Friction Loss in Feet Per 100 Feet of Setting								
		1000-2600 GPM								
		1000	1200	1400	1600	1800	2000	2200	2400	2600
8 x 1 1/2	8 x 1	1.90	2.60	3.50	4.50	5.50	6.70	7.90	9.40	11.00
8 x 2	8 x 1 1/4	3.30	4.50	5.95	7.55	9.40	12.50	15.10	—	—
8 x 2 1/2	8 x 1 1/2	3.90	5.50	7.20	9.20	14.00	—	—	—	—
	8 x 1 11/16	3.90	5.50	7.20	9.20	14.00	—	—	—	—
8 x 3	8 x 1 5/16	5.40	7.50	9.98	13.00	16.40	—	—	—	—
	8 x 2 3/16	5.40	7.50	9.98	13.00	16.40	—	—	—	—
10 x 1 1/2	10 x 1	—	1.06	1.40	1.79	2.20	2.69	3.20	3.75	4.33
10 x 2	10 x 1 1/4	.89	1.20	1.59	2.02	2.50	3.02	3.60	4.20	4.90
10 x 2 1/2	10 x 1 1/2	1.0	1.38	1.81	2.30	2.88	3.50	4.10	4.80	5.60
	10 x 1 11/16	1.0	1.38	1.81	2.30	2.88	3.50	4.10	4.80	5.60
10 x 3	10 x 1 5/16	1.17	1.65	2.18	2.78	3.50	4.25	5.05	5.95	6.90
	10 x 2 3/16	1.17	1.65	2.18	2.78	3.50	4.25	5.05	5.95	6.90
12 x 2	12 x 1 1/4	—	—	—	—	.99	1.20	1.42	1.68	1.92
12 x 2 1/2	12 x 1 1/2	—	—	—	.90	1.11	1.36	1.60	1.89	2.18
	12 x 1 11/16	—	—	—	.90	1.11	1.36	1.60	1.89	2.18
12 x 3	12 x 1 5/16	—	—	—	1.04	1.29	1.57	1.85	2.18	2.50
	12 x 2 3/16	—	—	—	1.04	1.29	1.57	1.85	2.18	2.50
12 x 3 1/2	12 x 2 7/16	—	—	1.02	1.30	1.65	1.95	2.35	2.76	3.23
14 x 2 1/2	14 x 1 1/2	—	—	—	—	—	—	.95	1.13	1.30
	14 x 1 11/16	—	—	—	—	—	—	.95	1.13	1.30
14 x 3	14 x 1 5/16	—	—	—	—	—	—	1.07	1.26	1.46
	14 x 2 3/16	—	—	—	—	—	—	1.07	1.26	1.46
14 x 3 1/2	14 x 2 7/16	—	—	—	—	—	1.05	1.24	1.46	1.68



6900/7000  
APPLICATION & REFERENCE DATA

COLUMN FRICTION LOSS CHART

Column and Enclosing Tube Size	Column and Open Lineshaft Size	Friction Loss in Feet Per 100 Feet of Setting								
		2800-4400 GPM								
		2800	3000	3200	3400	3600	3800	4000	4200	4400
8 x 1½	8 x 1	12.80	14.70	16.70	—	—	—	—	—	—
10 x 1½	10 x 1	5.00	5.65	6.35	7.05	7.85	8.70	9.60	10.60	11.60
10 x 2	10 x 1¼	5.60	6.40	7.15	8.00	8.90	9.80	12.00	14.50	—
10 x 2½	10 x 1½	6.40	7.25	8.20	9.10	10.50	12.50	13.50	14.90	—
	10 x 1⅞	6.40	7.25	8.20	9.10	10.50	12.50	13.50	14.90	—
10 x 3	10 x 1⅝	7.90	8.95	9.99	12.00	13.50	14.50	—	—	—
	10 x 2⅞	7.90	8.95	9.99	12.00	13.50	14.50	—	—	—
12 x 2	12 x 1¼	2.20	2.50	2.80	3.15	3.50	3.85	4.20	4.60	5.10
12 x 2½	12 x 1½	2.50	2.87	3.20	3.60	4.00	4.40	4.80	5.25	5.80
	12 x 1⅞	2.50	2.87	3.20	3.60	4.00	4.40	4.80	5.25	5.80
12 x 3	12 x 1⅝	2.90	3.30	3.72	4.15	4.60	5.15	5.65	6.15	6.70
	12 x 2⅞	2.90	3.30	3.72	4.15	4.60	5.15	5.65	6.15	6.70
12 x 3½	12 x 2⅞	3.69	4.20	4.73	5.28	5.90	5.55	7.25	7.85	8.60
14 x 2½	14 x 1½	1.50	1.68	1.90	2.14	2.38	2.62	2.90	3.15	3.45
	14 x 1⅞	1.50	1.68	1.90	2.14	2.38	2.62	2.90	3.15	3.45
14 x 3	14 x 1⅝	1.67	1.90	2.13	2.38	2.65	2.90	3.20	3.50	3.80
	14 x 2⅞	1.67	1.90	2.13	2.38	2.65	2.90	3.20	3.50	3.80
14 x 3½	14 x 2⅞	1.93	2.20	2.45	2.72	3.04	3.35	3.67	4.00	4.35
14 x 4	14 x 2⅞	2.01	2.30	2.55	2.85	3.17	3.50	3.85	4.20	4.55
14 x 5	14 x 2⅞ Thru 14 x 3⅞	2.52	2.87	3.20	3.60	4.00	4.40	4.85	5.25	5.70
16 x 2½	16 x 1½	—	—	—	1.03	1.14	1.25	1.37	1.49	1.63
	16 x 1⅞	—	—	—	1.03	1.14	1.25	1.37	1.49	1.63
16 x 3	16 x 1⅝	—	—	1.00	1.12	1.24	1.37	1.50	1.64	1.79
	16 x 2⅞	—	—	1.00	1.12	1.24	1.37	1.50	1.64	1.79
16 x 3½	16 x 2⅞	—	.99	1.12	1.25	1.38	1.53	1.68	1.83	2.00
16 x 4	16 x 2⅞	—	1.03	1.17	1.30	1.44	1.60	1.75	1.90	2.08
16 x 5	16 x 2⅞ Thru 16 x 3⅞	1.00	1.10	1.30	1.40	1.60	1.80	1.90	2.10	2.30

COLUMN FRICTION LOSS CHART

Column and Enclosing Tube Size	Column and Open Lineshaft Size	Friction Loss in Feet Per 100 Feet of Setting								
		4600-8000 GPM								
		4600	4800	5000	5500	6000	6500	7000	7500	8000
10 x 1½	10 x 1	12.70	13.80	15.00	—	—	—	—	—	—
10 x 2	10 x 1¼	14.40	15.60	—	—	—	—	—	—	—
12 x 2	12 x 1¼	5.50	5.90	6.40	7.60	9.00	10.60	12.30	14.10	16.00
12 x 2½	12 x 1½	6.30	6.80	7.30	8.70	10.40	12.20	14.10	16.20	—
	12 x 1⅞	6.30	6.80	7.30	8.70	10.40	12.20	14.10	16.20	—
12 x 3	12 x 1⅝	7.25	7.90	8.55	10.30	12.30	14.40	16.80	—	—
	12 x 2⅞	7.25	7.90	8.55	10.30	12.30	14.40	16.80	—	—
12 x 3½	12 x 2⅞	9.30	10.10	11.10	13.30	15.80	—	—	—	—
14 x 2½	14 x 1½	3.70	4.00	4.35	5.15	6.10	7.10	8.10	9.20	10.50
	14 x 1⅞	3.70	4.00	4.35	5.15	6.10	7.10	8.10	9.20	10.50
14 x 3	14 x 1⅝	4.10	4.45	4.80	5.70	6.70	7.70	8.90	10.20	11.60
	14 x 2⅞	4.10	4.45	4.80	5.70	6.70	7.70	8.90	10.20	11.60
14 x 3½	14 x 2⅞	4.72	5.15	5.53	6.50	7.65	8.85	10.30	11.18	13.40
14 x 4	14 x 2⅞	4.95	5.40	5.80	6.80	8.00	9.30	10.80	12.40	14.10
14 x 5	14 x 2⅞ Thru 14 x 3⅞	6.20	6.75	7.20	8.60	9.99	11.70	13.60	15.60	—
16 x 2½	16 x 1½	1.77	1.90	2.06	2.45	2.87	3.30	3.80	4.30	4.80
	16 x 1⅞	1.77	1.90	2.06	2.45	2.87	3.30	3.80	4.30	4.80
16 x 3	16 x 1⅝	1.93	2.10	2.25	2.70	3.13	3.60	4.15	4.70	5.25
	16 x 2⅞	1.93	2.10	2.25	2.70	3.13	3.60	4.15	4.70	5.25
16 x 3½	16 x 2⅞	2.16	2.32	2.52	2.98	3.48	4.03	4.62	5.27	5.87
16 x 4	16 x 2⅞	2.25	2.42	2.63	3.10	3.60	4.20	4.80	5.50	6.10
16 x 5	16 x 2⅞ Thru 16 x 3⅞	2.50	2.70	2.90	3.50	4.10	4.70	5.40	6.10	6.85





6900/7000  
APPLICATION & REFERENCE DATA

COLUMN FRICTION LOSS CHART

Column and Enclosing Tube Size	Column and Open Lineshaft Size	Friction Loss in Feet Per 100 Feet of Setting								
		8500-12000 GPM								
		8500	9000	9500	10000	10500	11000	11500	12000	—
14 x 2 1/2	14 x 1 1/2	11.80	13.20	14.80	16.40	—	—	—	—	—
	14 x 1 11/16	11.80	13.20	14.80	16.40	—	—	—	—	—
14 x 3	14 x 1 5/16	13.10	14.70	16.40	—	—	—	—	—	—
	14 x 2 3/16	13.10	14.70	16.40	—	—	—	—	—	—
14 x 3 1/2	14 x 2 1/16	13.10	—	—	—	—	—	—	—	—
14 x 4	14 x 2 11/16	15.90	—	—	—	—	—	—	—	—
16 x 2 1/2	16 x 1 1/2	5.40	6.00	6.60	7.25	7.99	8.77	9.59	10.40	—
	16 x 1 11/16	5.40	6.00	6.60	7.25	7.99	8.77	9.59	10.40	—
16 x 3	16 x 1 5/16	5.90	6.50	7.20	7.90	8.71	9.56	10.40	11.40	—
	16 x 2 3/16	5.90	6.50	7.20	7.90	8.71	9.56	10.40	11.40	—
16 x 3 1/2	16 x 2 1/16	6.55	7.30	8.05	8.85	9.76	10.70	11.70	12.70	—
16 x 4	16 x 2 11/16	6.80	7.60	8.40	9.20	10.10	11.10	12.20	13.20	—
16 x 5	16 x 2 5/16 Thru 16 x 3 11/16	7.60	8.30	9.00	9.80	10.80	11.90	13.00	14.10	—
18 x 3	18 x 1 5/16	3.70	4.20	4.60	5.00	5.50	6.00	6.40	7.00	—
	18 x 2 3/16	3.70	4.20	4.60	5.00	5.50	6.00	6.40	7.00	—
18 x 3 1/2	18 x 2 1/16	4.20	4.60	5.15	5.60	6.10	6.60	7.20	7.80	—
18 x 4	18 x 2 11/16	4.55	5.10	5.60	6.20	6.70	7.30	8.00	8.60	—
18 x 5	18 x 2 5/16 Thru 18 x 3 11/16	6.20	6.90	7.60	8.35	9.20	10.00	13.20	14.40	—
20 x 3	20 x 1 5/16	1.90	2.10	2.35	2.55	2.80	3.05	3.30	3.55	—
	20 x 2 3/16	1.90	2.10	2.35	2.55	2.80	3.05	3.30	3.55	—
20 x 3 1/2	20 x 2 1/16	2.20	2.50	2.75	3.00	3.30	3.55	3.85	4.20	—
20 x 4	20 x 2 11/16	2.55	2.85	3.07	3.45	3.80	4.10	4.50	4.85	—
20 x 5	20 x 2 5/16 Thru 20 x 3 11/16	3.40	3.75	4.15	4.55	5.00	5.40	5.85	6.30	—
24 x 3 1/2	24 x 2 1/16	—	—	—	—	1.05	1.12	1.20	1.32	—
24 x 4	24 x 2 11/16	—	—	—	1.08	1.20	1.30	1.40	1.50	—
24 x 5	24 x 2 5/16 Thru 24 x 3 11/16	1.04	1.15	1.32	1.40	1.54	1.65	1.80	1.94	—

COLUMN FRICTION LOSS CHART

Column and Enclosing Tube Size	Column and Open Lineshaft Size	Friction Loss in Feet Per 100 Feet of Setting								
		12500-16000 GPM								
		12500	13000	13500	14000	14500	15000	15500	16000	—
16 x 2 1/2	16 x 1 1/2	11.30	12.30	13.20	14.20	15.20	—	—	—	—
	16 x 1 11/16	11.30	12.30	13.20	14.20	15.20	—	—	—	—
16 x 3	16 x 1 5/16	12.30	13.40	14.40	15.50	—	—	—	—	—
	16 x 2 3/16	12.30	13.40	14.40	15.50	—	—	—	—	—
16 x 3 1/2	16 x 2 1/16	13.80	15.00	—	—	—	—	—	—	—
16 x 4	16 x 2 11/16	14.30	15.50	—	—	—	—	—	—	—
16 x 5	16 x 2 5/16 Thru 16 x 3 11/16	15.30	—	—	—	—	—	—	—	—
18 x 3	18 x 1 5/16	7.50	8.10	8.70	9.30	10.00	10.70	11.40	12.20	—
	18 x 2 3/16	7.50	8.10	8.70	9.30	10.00	10.70	11.40	12.20	—
18 x 3 1/2	18 x 2 1/16	8.20	9.00	9.80	10.50	11.30	12.10	12.90	13.80	—
18 x 4	18 x 2 11/16	9.20	10.00	10.80	11.50	12.40	13.30	14.20	15.10	—
18 x 5	18 x 2 5/16 Thru 18 x 3 11/16	15.60	—	—	—	—	—	—	—	—
20 x 3	20 x 1 5/16	3.85	4.10	4.40	4.75	5.05	5.40	5.70	6.00	—
	20 x 2 3/16	3.85	4.10	4.40	4.75	5.05	5.40	5.70	6.00	—
20 x 3 1/2	20 x 2 1/16	4.50	4.85	5.25	5.60	6.00	6.30	6.80	7.10	—
20 x 4	20 x 2 11/16	5.20	5.60	6.00	6.40	6.90	7.30	7.80	8.20	—
20 x 5	20 x 2 5/16 Thru 20 x 3 11/16	6.80	7.30	7.80	8.40	9.00	9.60	10.30	10.90	—
24 x 3	24 x 1 5/16	1.25	1.35	1.45	1.55	1.65	1.77	1.87	2.00	—
	24 x 2 3/16	1.25	1.35	1.45	1.55	1.65	1.77	1.87	2.00	—
24 x 3 1/2	24 x 2 1/16	1.42	1.52	1.65	1.75	1.85	2.00	2.10	2.22	—
24 x 4	24 x 2 11/16	1.60	1.75	1.87	2.00	2.15	2.25	2.42	2.55	—
24 x 5	24 x 2 5/16 Thru 24 x 3 11/16	2.07	2.25	2.40	2.57	2.75	2.90	3.10	3.25	—



6900/7000  
APPLICATION & REFERENCE DATA

**COLUMN FRICTION LOSS CHART**

Column and Enclosing Tube Size	Column and Open Lineshaft Size	Friction Loss in Feet Per 100 Feet of Setting							
		16500-20000 GPM							
		16500	17000	17500	18000	18500	19000	19500	20000
18 x 3	18 x 1 <sup>5</sup> / <sub>16</sub>	12.90	13.70	14.60	15.40	—	—	—	—
	18 x 2 <sup>3</sup> / <sub>16</sub>	12.90	13.70	14.60	15.40	—	—	—	—
18 x 3 <sup>1</sup> / <sub>2</sub>	18 x 2 <sup>7</sup> / <sub>16</sub>	14.60	15.50	—	—	—	—	—	—
20 x 3	20 x 1 <sup>5</sup> / <sub>16</sub>	6.35	6.80	7.10	7.60	7.90	8.30	8.60	9.10
	20 x 2 <sup>3</sup> / <sub>16</sub>	6.35	6.80	7.10	7.60	7.90	8.30	8.60	9.10
20 x 3 <sup>1</sup> / <sub>2</sub>	20 x 2 <sup>7</sup> / <sub>16</sub>	7.50	8.00	8.40	8.90	9.30	9.80	10.30	10.90
20 x 4	20 x 2 <sup>11</sup> / <sub>16</sub>	8.70	9.20	9.70	10.20	10.80	11.40	12.00	12.70
20 x 5	20 x 2 <sup>15</sup> / <sub>16</sub>	11.60	12.30	13.10	13.80	14.60	15.40	—	—
	Thru 20 x 3 <sup>11</sup> / <sub>16</sub>								
24 x 3	24 x 1 <sup>5</sup> / <sub>16</sub>	2.10	2.23	2.30	2.45	2.55	2.70	2.82	3.00
	24 x 2 <sup>3</sup> / <sub>16</sub>	2.10	2.23	2.30	2.45	2.55	2.70	2.82	3.00
24 x 3 <sup>1</sup> / <sub>2</sub>	24 x 2 <sup>7</sup> / <sub>16</sub>	2.35	2.50	2.62	2.76	2.90	3.05	3.20	3.35
24 x 4	24 x 2 <sup>11</sup> / <sub>16</sub>	2.77	2.85	3.00	3.15	3.35	3.50	3.70	3.85
	24 x 2 <sup>15</sup> / <sub>16</sub>	3.50	3.65	3.85	4.05	4.25	4.50	4.70	5.00
Thru 24 x 3 <sup>11</sup> / <sub>16</sub>									
30 x 4	30 x 2 <sup>11</sup> / <sub>16</sub>	—	—	—	—	—	—	—	1.00
30 x 5	30 x 2 <sup>15</sup> / <sub>16</sub>	—	—	—	1.00	1.05	1.10	1.17	1.22
	Thru 30 x 3 <sup>11</sup> / <sub>16</sub>								

Column and Enclosing Tube Size	Column and Open Lineshaft Size	Friction Loss in Feet Per 100 Feet of Setting							
		25000-60000 GPM							
		25000	30000	35000	40000	45000	50000	55000	60000
20 x 3	20 x 1 <sup>5</sup> / <sub>16</sub>	16.20	—	—	—	—	—	—	—
	20 x 2 <sup>3</sup> / <sub>16</sub>	16.20	—	—	—	—	—	—	—
20 x 3 <sup>1</sup> / <sub>2</sub>	20 x 2 <sup>7</sup> / <sub>16</sub>	17.00	—	—	—	—	—	—	—
20 x 4	20 x 2 <sup>11</sup> / <sub>16</sub>	19.80	—	—	—	—	—	—	—
24 x 3	24 x 1 <sup>5</sup> / <sub>16</sub>	4.50	6.20	8.30	10.60	13.70	16.90	—	—
	24 x 2 <sup>3</sup> / <sub>16</sub>	4.50	6.20	8.30	10.60	13.70	16.90	—	—
24 x 3 <sup>1</sup> / <sub>2</sub>	24 x 2 <sup>7</sup> / <sub>16</sub>	5.10	7.10	9.40	12.30	15.50	—	—	—
24 x 4	24 x 2 <sup>11</sup> / <sub>16</sub>	6.00	8.67	11.80	15.40	—	—	—	—
	24 x 2 <sup>15</sup> / <sub>16</sub>	7.40	10.50	14.30	18.70	—	—	—	—
Thru 24 x 3 <sup>11</sup> / <sub>16</sub>									
30 x 4	30 x 2 <sup>11</sup> / <sub>16</sub>	1.53	2.12	2.87	3.70	4.60	5.60	6.70	7.90
30 x 5	30 x 2 <sup>15</sup> / <sub>16</sub>	1.75	2.50	3.30	4.20	5.20	6.30	7.50	8.80
	Thru 30 x 3 <sup>11</sup> / <sub>16</sub>								



Shaft Diameter	Lineshaft Loss Chart Horsepower Loss Per 100 Feet of Setting										
	Speed (RPM)										
	3600	2900	1800	1500	1200	1000	900	750	720	600	514
1"	1.10	.88	.55	.45	.35	.30	.27	—	—	—	—
1 1/4"	1.50	1.35	.81	.68	.52	.44	.40	—	—	—	—
1 1/2"	2.30	1.90	1.20	.96	.75	.60	.55	—	—	—	—
1 11/16"	2.80	2.40	1.40	1.20	.94	.78	.70	.60	.55	.49	—
1 5/16"	3.70	3.10	1.90	1.60	1.20	1.00	.90	.79	.72	.63	—
2 3/16"	—	—	2.30	2.00	1.50	1.40	1.30	1.20	1.10	.80	—
2 7/16"	—	—	2.90	2.40	1.90	1.60	1.40	1.30	1.20	.96	.88
2 11/16"	—	—	3.40	2.90	2.30	1.90	1.70	1.60	1.50	1.30	1.10
2 5/16"	—	—	4.10	3.50	2.70	2.30	2.00	1.80	1.70	1.40	1.10
3 3/16"	—	—	5.20	4.30	3.40	2.80	2.50	2.10	2.00	1.70	1.50
3 7/16"	—	—	6.00	4.80	3.90	3.30	3.00	2.40	2.30	1.90	1.50
3 11/16"	—	—	7.00	5.90	4.50	3.80	3.50	2.80	2.70	2.10	1.70
4"	—	—	—	—	4.90	4.00	3.70	3.20	3.00	2.50	2.30
4 1/2"	—	—	—	—	—	5.00	4.40	4.00	3.70	3.10	2.60
5"	—	—	—	—	—	—	—	4.90	4.50	3.80	3.40
5 1/2"	—	—	—	—	—	—	—	—	—	4.30	3.90
6"	—	—	—	—	—	—	—	—	—	—	4.50

Elbow Size	Discharge Elbow Loss Chart "C", "D", & "H" Heads									
	Flow (GPM)									
	400	450	500	600	700	800	900	1000	1200	1400
4	.25	.55	.90	1.75	2.75	3.90	4.90	—	—	—
6	—	—	—	—	—	—	—	.45	1.05	1.80
Elbow Size	Flow (GPM)									
	1600	1800	2000	2200	2400	2600	3000	3400	3800	4200
6	2.60	3.55	4.60	5.70	—	—	—	—	—	—
8	—	.55	.90	1.25	1.75	2.20	3.25	4.40	5.70	—
10	—	—	—	—	—	—	—	1.20	1.75	2.35
Elbow Size	Flow (GPM)									
	4200	4600	5000	6000	7000	8000	9000	10000	12000	
10	2.35	3.10	3.75	5.80	—	—	—	—	—	
12	.65	.95	1.30	2.30	3.45	4.80	—	—	—	
14	—	—	.25	.80	1.45	2.15	3.00	3.90	6.00	

The above tabulation shows the additional elbow friction losses encountered when handling capacities greater than maximum recommended capacity for a given head.



6900/7000  
APPLICATION & REFERENCE DATA

Elbow Size	Discharge Elbow Loss Chart "L", "LS", "T" & "UG" Heads									
	Flow (GPM)									
	200	250	300	350	400	450	500	600	700	800
4	.35	.46	.78	1.06	1.39	1.76	2.17	3.12	4.26	5.56
6	—	—	—	—	—	.34	.42	.61	.83	1.08
8	—	—	—	—	—	—	—	—	.27	.36
Elbow Size	Flow (GPM)									
	1000	1200	1400	1600	1800	2000	2200	2400	2600	3000
6	1.69	2.43	3.31	4.32	5.46	6.74	—	—	—	—
8	.56	.81	1.11	1.44	1.82	2.25	2.71	3.23	3.80	5.06
10	—	—	.44	.58	.73	.91	1.09	1.30	1.75	2.03
12	—	—	—	—	.36	.45	.54	.65	.76	1.01
14	—	—	—	—	—	—	—	.45	.53	.70
16	—	—	—	—	—	—	—	—	—	.40
Elbow Size	Flow (GPM)									
	3500	4000	5000	6000	7000	8000	9000	10000	11000	12000
10	2.76	3.63	5.65	8.18	—	—	—	—	—	—
12	1.37	1.80	2.81	4.05	5.51	7.19	—	—	—	—
14	.94	1.23	2.46	2.76	3.77	4.92	6.23	—	—	—
16	.55	.72	1.13	1.62	2.21	2.89	3.65	3.87	4.80	5.63
18	—	.45	.70	.82	1.12	1.47	1.85	2.29	2.82	3.34
20	—	—	.46	.66	.75	.99	1.25	1.54	1.85	2.24
24	—	—	—	—	.43	.55	.70	.73	.88	1.06
Elbow Size	Flow (GPM)									
	13000	14000	15000	16000	17000	18000	19000	20000	25000	30000
18	4.73	5.52	6.32	7.21	—	—	—	—	—	—
20	3.08	3.59	4.09	4.66	5.28	5.90	6.56	7.29	—	—
24	1.48	1.71	1.97	2.23	2.53	2.82	3.16	3.48	5.46	7.84
30	.55	.63	.73	.83	.93	1.05	1.16	1.29	2.02	2.90
36	—	—	—	—	—	.44	.50	.55	.85	1.22
Elbow Size	Flow (GPM)									
	35000	40000	45000	50000	60000					
24	10.74	—	—	—	—					
30	3.95	5.17	6.53	8.07	—					
36	1.66	2.17	2.75	3.40	4.89					





Elbow Size	Discharge Elbow Loss Chart "F" & "UF" Heads									
	Flow (GPM)									
	200	250	300	350	400	450	500	600	700	800
4	.20	.31	.45	.61	.79	1.0	1.24	1.78	2.42	3.16
6	—	—	—	—	.15	.19	.24	.35	.47	.61
8	—	—	—	—	—	—	—	—	.16	.21
Elbow Size	Flow (GPM)									
	1000	1200	1400	1600	1800	2000	2200	2400	2600	3000
6	.96	1.38	1.88	2.46	3.15	3.84	—	—	—	—
8	.32	.46	.63	.82	1.04	1.28	1.54	1.83	2.16	2.87
10	—	—	.25	.33	.44	.51	.62	.74	.86	1.15
12	—	—	—	—	—	.26	.31	.37	.44	.57
14	—	—	—	—	—	—	—	.25	.30	.40
16	—	—	—	—	—	—	—	—	—	.23
Elbow Size	Flow (GPM)									
	3500	4000	5000	6000	7000	8000	9000	10000	11000	12000
10	1.57	2.06	3.21	4.64	6.30	8.20	—	—	—	—
12	.78	1.02	1.60	2.30	3.13	4.08	5.15	—	—	—
14	.54	.70	1.09	1.57	2.14	2.80	3.54	3.80	4.60	5.45
16	.32	.41	.64	.92	1.25	1.64	2.07	2.20	2.70	3.20
18	—	.26	.40	.58	.79	1.03	1.30	1.60	1.90	2.30
20	—	—	.26	.38	.51	.66	.84	1.04	1.76	1.99
24	—	—	—	—	.25	.32	.40	.50	.60	.71
Elbow Size	Flow (GPM)									
	13000	14000	15000	16000	17000	18000	19000	20000	25000	30000
18	2.69	3.14	3.59	4.20	—	—	—	—	—	—
20	1.75	2.04	2.33	2.65	3.00	3.36	3.73	4.14	—	—
24	.84	.97	1.12	1.27	1.44	1.61	1.80	1.98	3.10	4.46
30	.31	.36	.42	.47	.53	.60	.66	.74	1.15	1.65
36	—	—	—	—	—	.25	.28	.31	.48	.69
Elbow Size	Flow (GPM)									
	35000	40000	45000	50000	60000					
24	6.10	—	—	—	—					
30	2.25	2.94	3.71	4.59	6.60					
36	.95	1.24	1.57	1.93	2.78					



6900/7000  
APPLICATION & REFERENCE DATA

CAN SELECTION CHART

Pump Size	Column Size	Max. Bowl or Column Flange O.D.	Allowable Capacity (GPM) at a Velocity of 6 Ft./Sec. (1)												
			Can Size												
			8"	10"	12"	14"	16"	18"	20"	24"	30"	36"	42"		
6M	4	6.6	316	885	—	—	—	—	—	—	—	—	—	—	—
7M	4	6.6	316	885	—	—	—	—	—	—	—	—	—	—	—
8M	4	8.0	—	585	1206	—	—	—	—	—	—	—	—	—	—
	6	9.2	—	282	903	1334	2171	—	—	—	—	—	—	—	—
10M	4	10.0	—	—	678	1109	1946	2900	—	—	—	—	—	—	—
	6	10.0	—	—	678	1109	1946	2900	—	—	—	—	—	—	—
11M	6	11.38	—	—	—	676	1513	2467	—	—	—	—	—	—	—
	8	11.80	—	—	—	533	1370	2324	—	—	—	—	—	—	—
11H	6	11.48	—	—	—	643	1479	2434	3505	—	—	—	—	—	—
	8	11.80	—	—	—	533	1370	2324	3395	—	—	—	—	—	—
12L	6	11.62	—	—	—	595	1432	2386	—	—	—	—	—	—	—
	8	11.80	—	—	—	533	1370	2324	—	—	—	—	—	—	—
12M	6	13.00	—	—	—	—	933	1887	2959	—	—	—	—	—	—
	8	13.00	—	—	—	—	933	1887	2959	—	—	—	—	—	—
12H	6	11.50	—	—	—	—	1473	2427	3498	—	—	—	—	—	—
	8	11.80	—	—	—	—	1370	2324	3395	—	—	—	—	—	—
13H	8	13.00	—	—	—	—	933	1887	2959	5454	—	—	—	—	—
	10	13.90	—	—	—	—	—	1532	2604	5099	—	—	—	—	—
14M	8	14.75	—	—	—	—	—	1174	2246	4741	—	—	—	—	—
	10	14.75	—	—	—	—	—	1174	2246	4741	—	—	—	—	—
	8	15.00	—	—	—	—	—	—	2137	4633	9257	—	—	—	—
15H	10	15.00	—	—	—	—	—	—	2137	4633	9257	—	—	—	—
	12	16.40	—	—	—	—	—	—	1492	3987	8611	—	—	—	—
17M	12	18.00	—	—	—	—	—	—	—	3179	7804	13484	—	—	—
	14	18.00	—	—	—	—	—	—	—	3179	7804	13484	—	—	—
17H	12	16.92	—	—	—	—	—	—	1237	3733	8357	14038	—	—	—
	14	17.60	—	—	—	—	—	—	893	3388	8013	13694	—	—	—
21H	14	20.75	—	—	—	—	—	—	—	—	6239	11920	18658	—	—
	16	20.75	—	—	—	—	—	—	—	—	6239	11920	18658	—	—

(1) Note: When pumping liquid hydrocarbons, the allowable capacities shown above should be reduced by 50% to produce a maximum velocity of 3 feet per second.



DR BY DENNIS E. DYE  
 DATE 1-29-85  
 CHECKED BY [Signature]  
 DATE 1-85  
 ENGINEERING APPROVAL [Signature]  
 DATE [ ]  
 MARKETING APPROVAL [ ]  
 DATE [ ]  
 DRAWING NUMBER 24LYAS  
 24LYAS

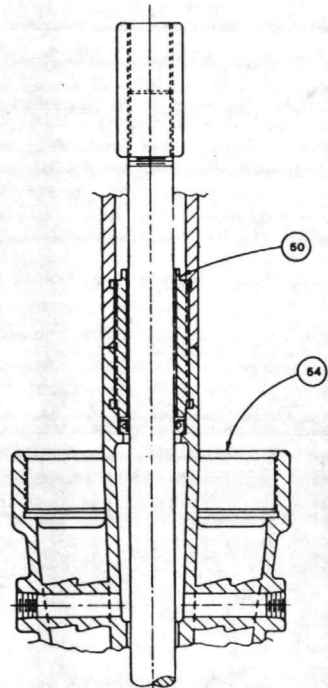

OPTIONAL ENCLOSED LINE SHAFT

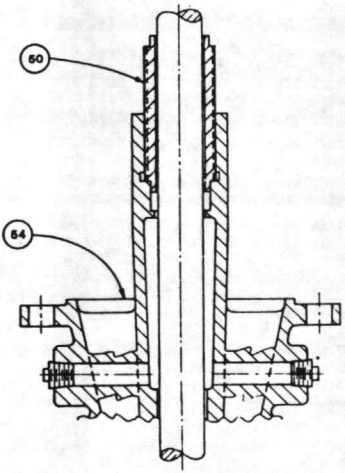

OPTIONAL FLANGED DISCHARGE

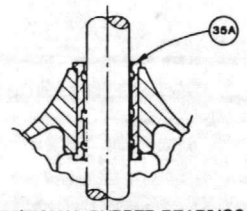
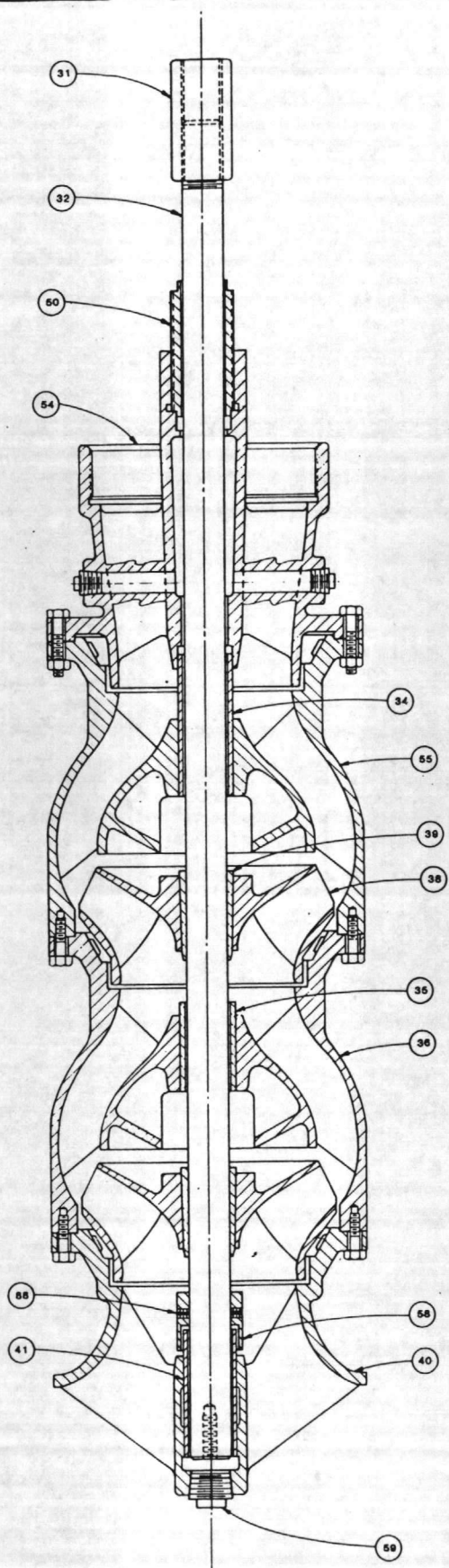

OPTIONAL RUBBER BEARINGS

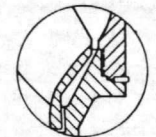

OPTIONAL THREADED BOWLS



OPTIONAL BOWL RING

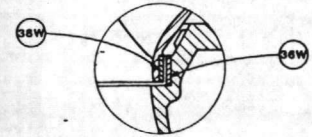

OPTIONAL BOWL & IMPELLER RING

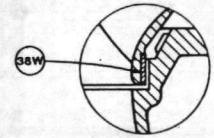

OPTIONAL IMPELLER RING

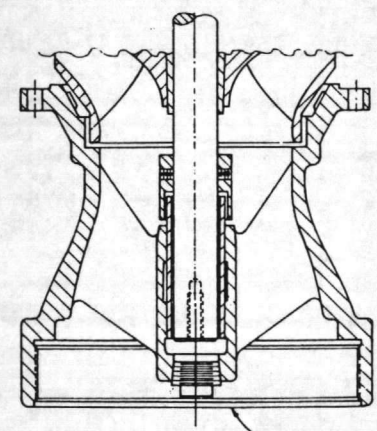

OPTIONAL SUCTION CASE 40A

ER2-12164

REV.	DATE	ECN NO.
1	2/1/86	EC2-13179

Coit Industries  Fairbanks Morse Pump Division  
**ASSEMBLY**  
**6M THRU 17H**  
**FIG 7000**  
 SIZE DWG. NO. 24LYA3455  
 C



DRAWN BY DENNIS E. DYE  
 DATE 2-85  
 CHECKED BY *James E. Dye*  
 DATE 4/85  
 ENGINEERING APPROVAL

DATE  
 MARKETING APPROVAL  
 DATE  
 DRAWING NUMBER

25LYA34

1	2/1/86	EC2-13179
REV.	DATE	ECN NO.

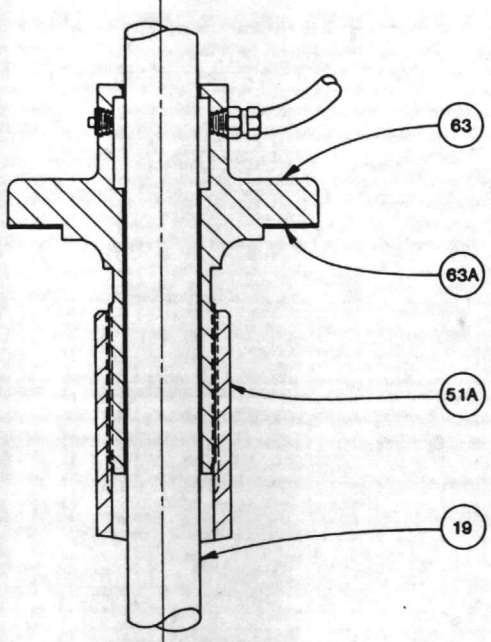

**TENSION NUT**  
(OIL LUBRICATED)

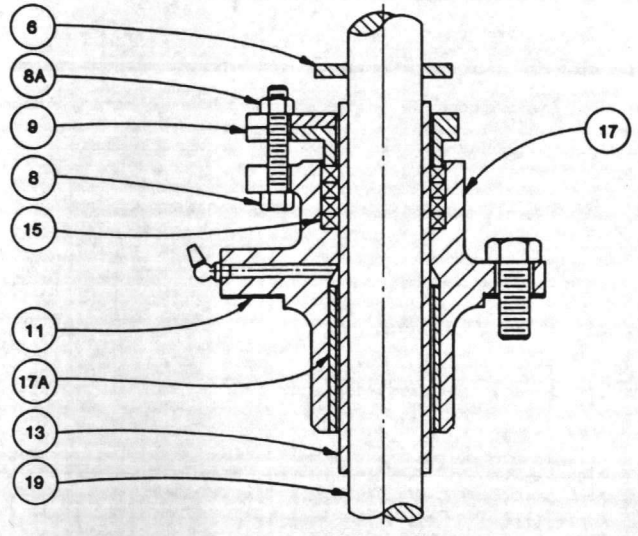

**PACKING BOX**  
(175 PSI RATING)

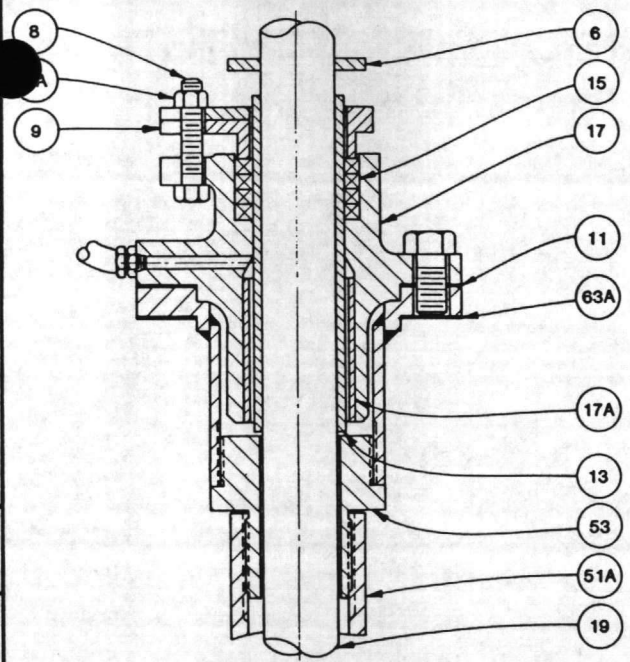

**PACKING BOX**  
(WATER FLUSH)

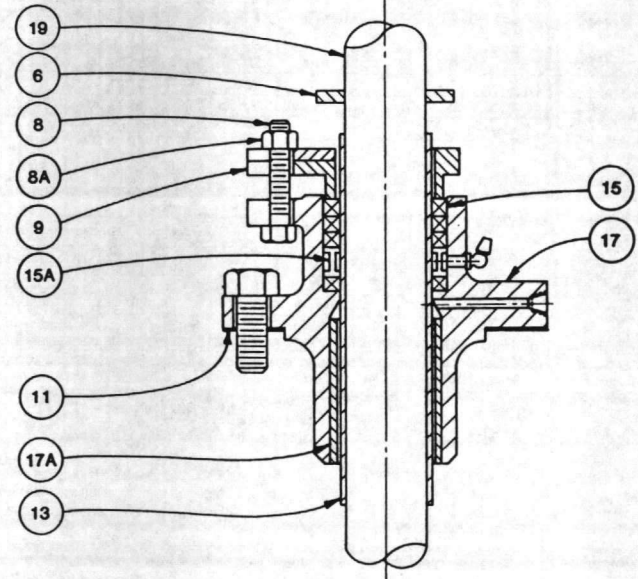

**PACKING BOX**  
(175 PSI W/BY-PASS)  
(400 PSI RATING)

NOTE: 400 PSI PACKING BOX REQUIRES SIX BOLTS

Fairbanks Morse Pump Corporation	
SHAFT SEAL	
DETAIL	
ASSEMBLY	
SIZE C	DWG. NO. 25LYA3463A





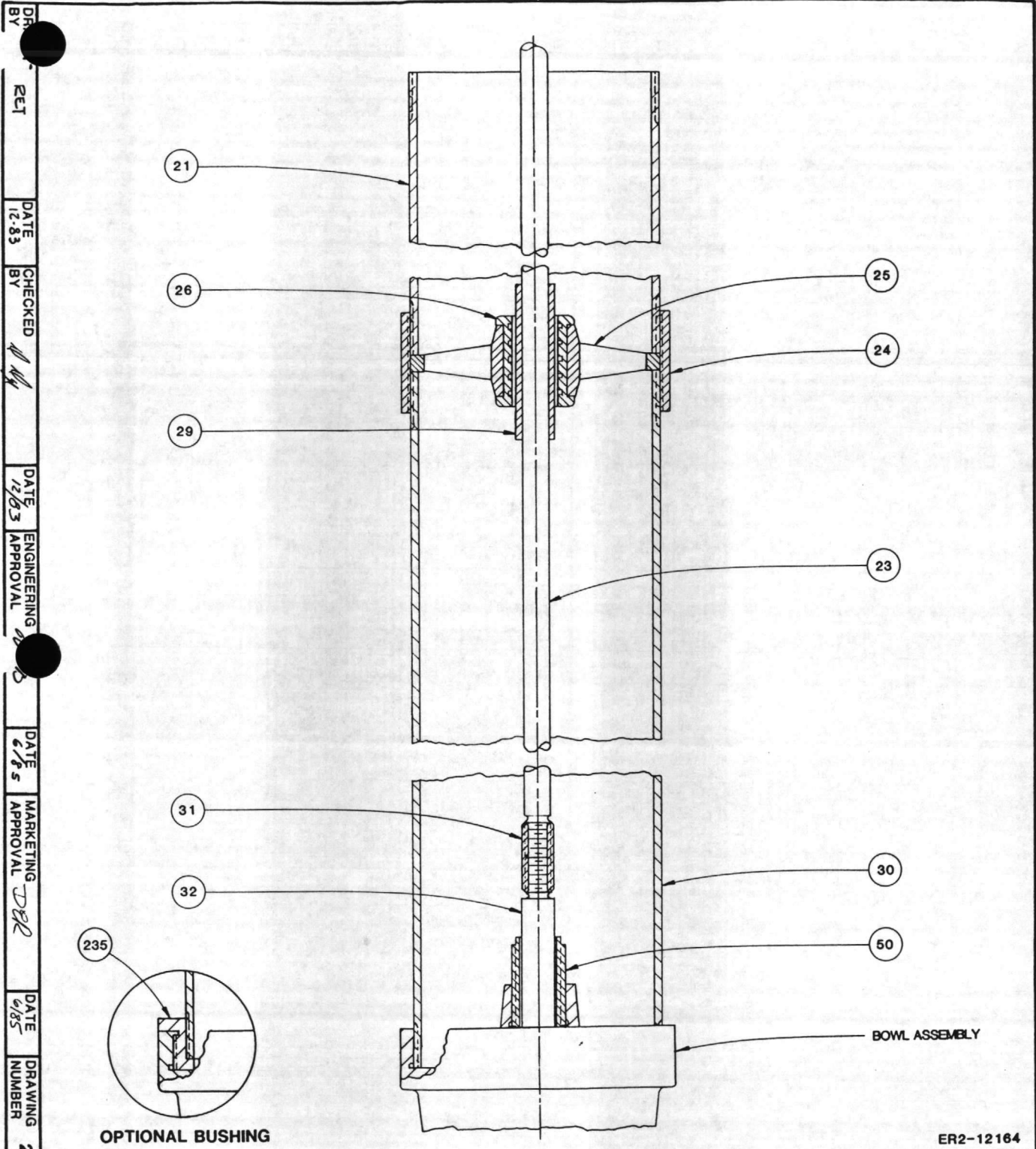

DR BY  
 Rel  
 DATE 12-83  
 CHECKED BY  
 DATE 12/83  
 ENGINEERING APPROVAL  
 DATE 6/85  
 MARKETING APPROVAL  
 DATE 6/85  
 DRAWING NUMBER 24LYA2363

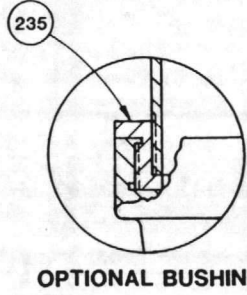

ER2-12164

Fairbanks Morse  
 Pump Corporation  
**ASSEMBLY**  
**THREADED COLUMN**  
**&**  
**OPEN LINESHAFT**  
 SIZE DWG. NO. **24LYA2363BA**

REV.	DATE	ECN NO.
2	2/1/86	EC2-13179
1	5/16/85	ER2-12874



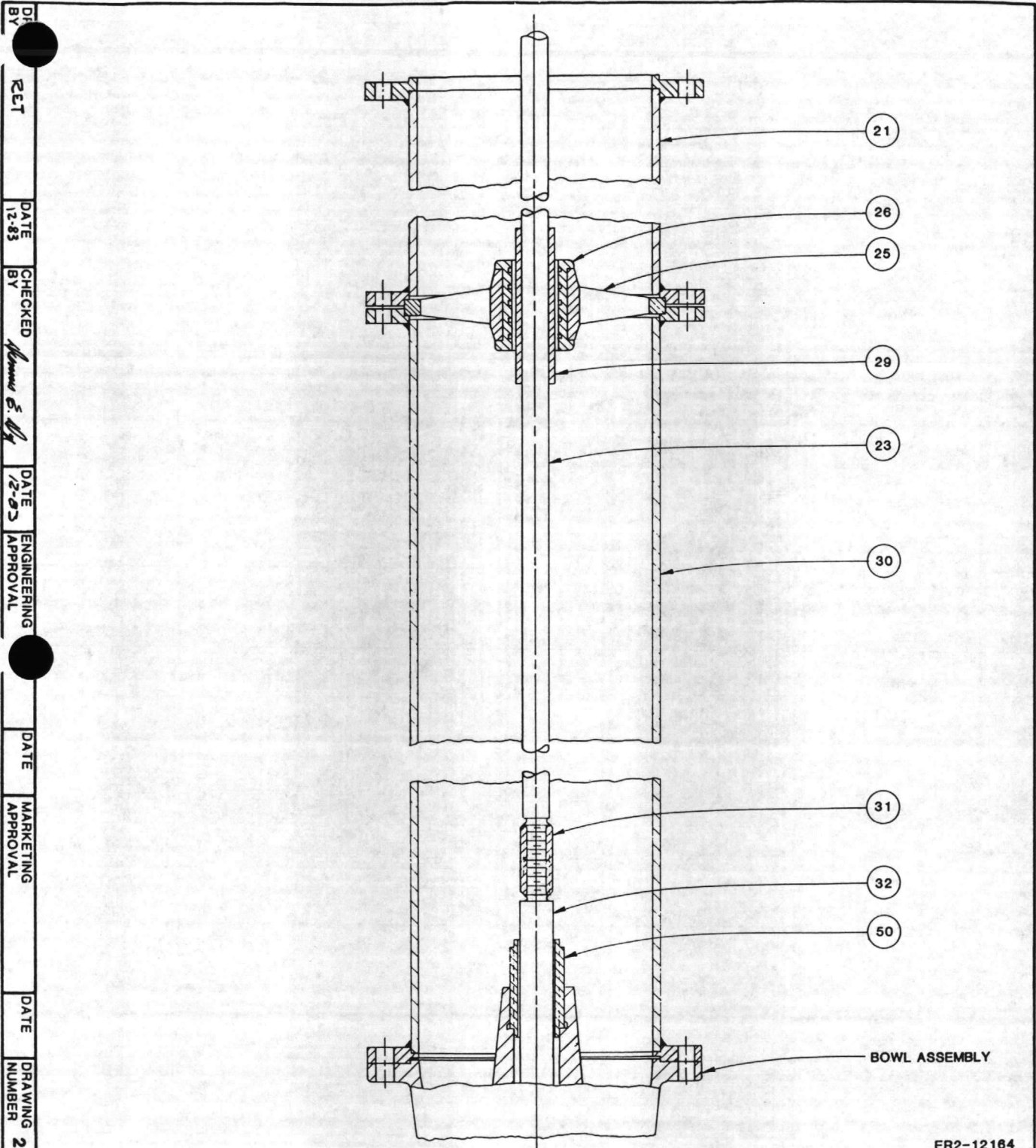

DRAWING NUMBER 24LYA2363  
 DATE 12-83  
 CHECKED BY *James S. Dy*  
 DATE 1-2-85  
 ENGINEERING APPROVAL  
 DATE  
 MARKETING APPROVAL  
 DATE  
 DRAWING NUMBER 24LYA2363

ER2-12164

Fairbanks Morse  
 Pump Corporation  
**ASSEMBLY  
 FLANGED COLUMN  
 &  
 OPEN LINESHAFT**

SIZE C DWG. NO. 24LYA2363AX

1	2/1/86	EC2-13179
REV.	DATE	ECN NO.



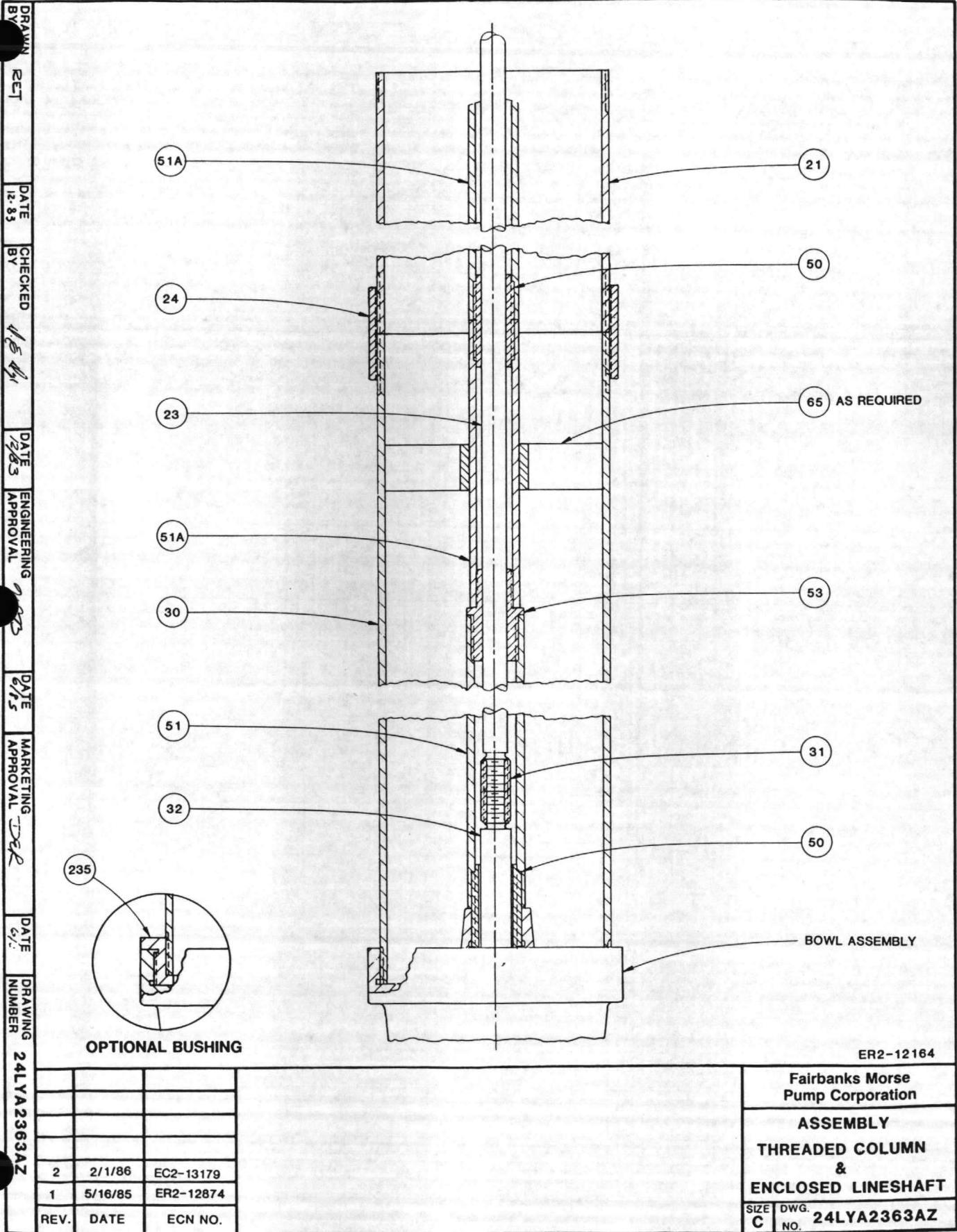

REV.	DATE	ECN NO.
2	2/1/86	EC2-13179
1	5/16/85	ER2-12874

ER2-12164

**Fairbanks Morse  
Pump Corporation**

**ASSEMBLY  
THREADED COLUMN  
&  
ENCLOSED LINESHAFT**

SIZE <b>C</b>	DWG. NO. <b>24LYA2363AZ</b>
------------------	--------------------------------

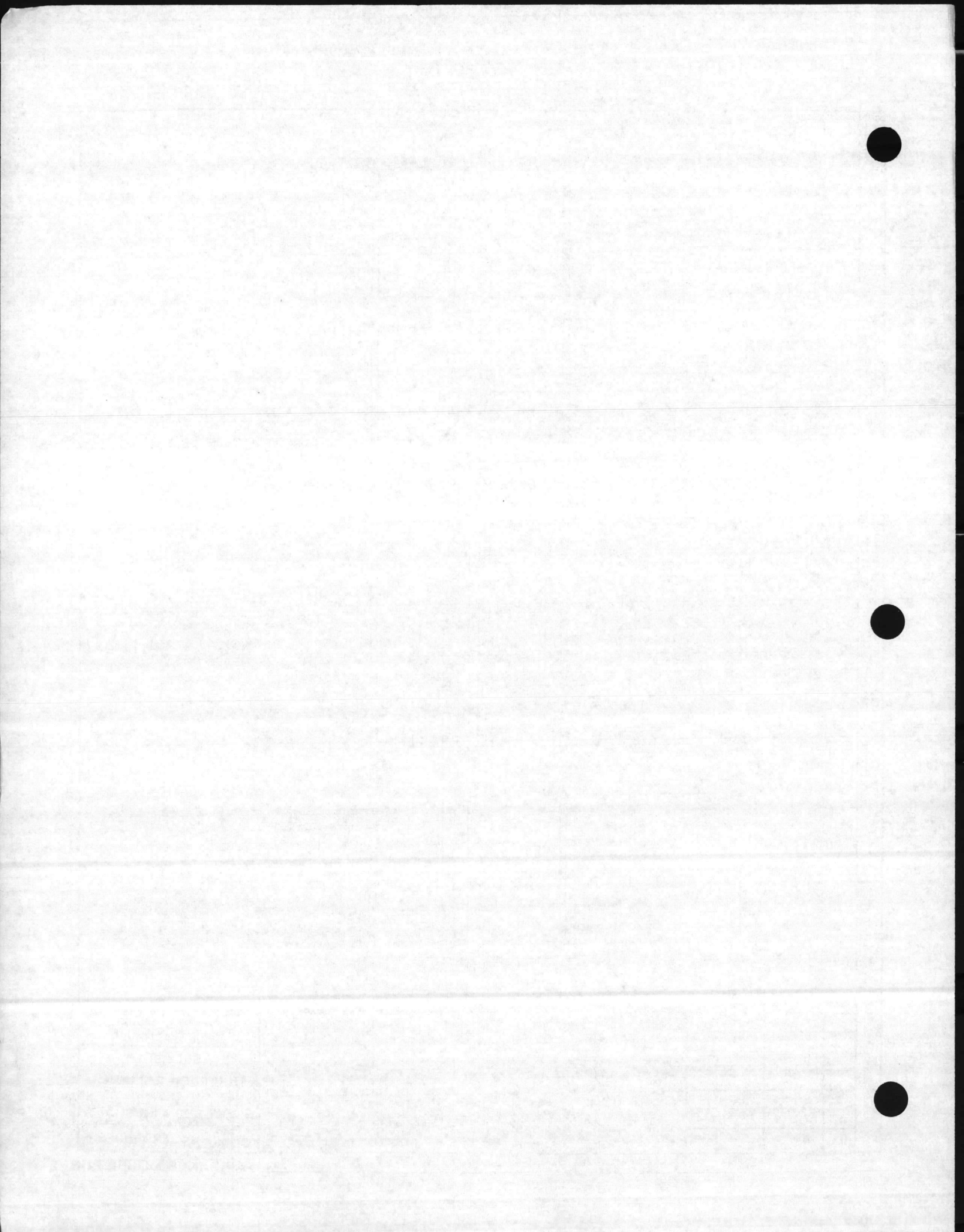

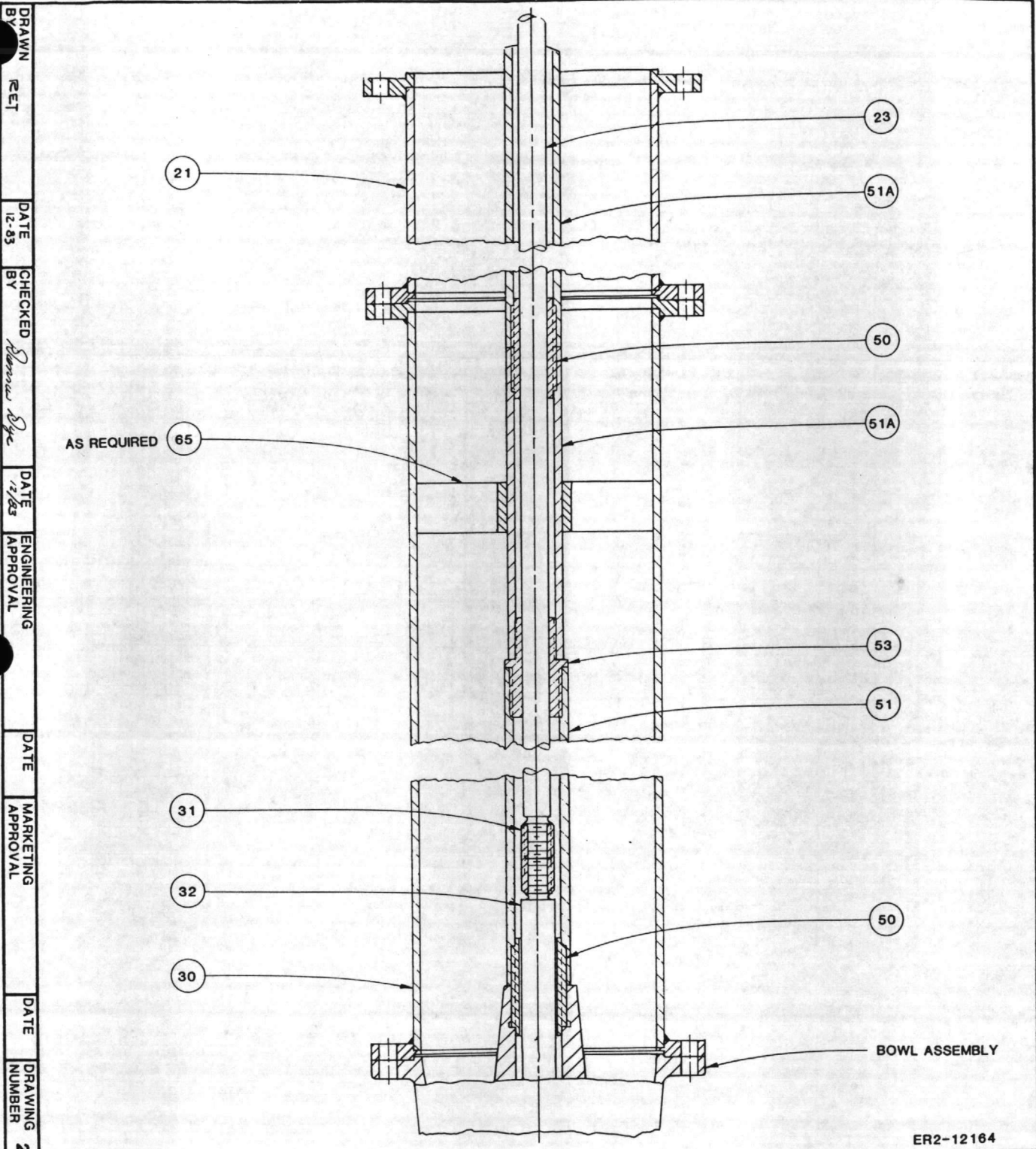

DRAWN BY RET  
 DATE 12-83  
 CHECKED BY *Bernard Dye*  
 DATE 1/83  
 ENGINEERING APPROVAL  
 DATE  
 MARKETING APPROVAL  
 DATE  
 DRAWING NUMBER 24LYA2363BB

REV.	DATE	ECN NO.
1	2/1/86	EC2-13179

ER2-12164

**Fairbanks Morse  
 Pump Corporation**

**ASSEMBLY  
 FLANGED COLUMN  
 &  
 ENCLOSED LINESHAFT**

SIZE <b>C</b>	DWG. NO. <b>24LYA2363BB</b>
------------------	--------------------------------

**FAIRBANKS MORSE PUMPS**

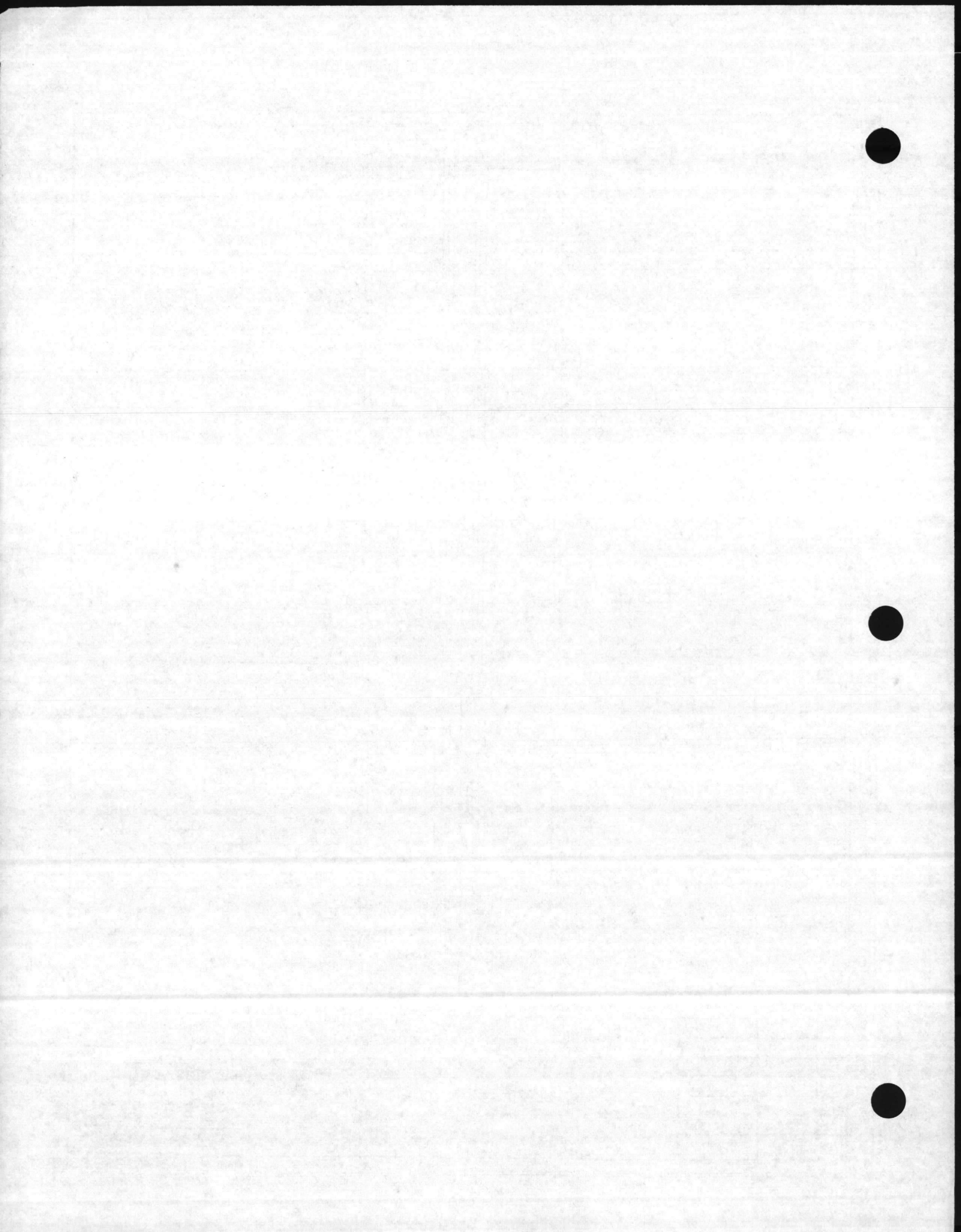



**VERTICAL TURBINE PUMPS  
MATERIAL SPECIFICATIONS**

**24LYA2363BA — THREADED COLUMN AND OPEN LINESHAFT**

Reference Number	Part Name	Material	Specification (1)
21	Top Column	Steel	See Note 2
23	Lineshaft	Steel	AISI 1045
24	Column Coupling	Steel	A53 GR B
25	Bearing Retainer	Bronze	B584 Alloy 836
26	Bearing	Rubber	Neoprene
29	Lineshaft Sleeve	Stainless Steel	AISI 304
30	Bottom Column	Steel	See Note 2
31	Shaft Coupling	Steel	A108 GR 12L14
32	Pump Shaft	Stainless Steel	A582-416
50	Connector Bearing	Bronze	B505 Alloy 932
235	Column Reducing Bushing	Cast Iron	A48 Class 30

**24LYA2363AZ — THREADED COLUMN AND ENCLOSED LINESHAFT**

Reference Number	Part Name	Material	Specification (1)
21	Top Column	Steel	See Note 2
23	Lineshaft	Steel	AISI 1045
24	Column Coupling	Steel	A53 GR B
30	Bottom Column	Steel	See Note 2
31	Shaft Coupling	Steel	A108 GR 12L14
32	Pump Shaft	Stainless Steel	A582-416
50	Connector Bearing	Bronze	B505 Alloy 932
51	Bottom Enclosing Tube	Steel	See Note 2
51A	Enclosing Tube	Steel	See Note 2
53	Step Connector Bearing	Bronze	B505 Alloy 932
65	Tube Stabilizer	Rubber	Natural
235	Column Reducing Bushing	Cast Iron	A48 Class 30

NOTE: 1. ALL MATERIAL SPECIFICATIONS ARE ASTM UNLESS OTHERWISE NOTED AND ARE FOR DESCRIPTION OF CHEMISTRY ONLY.

NOTE: 2. ALL CIRCULAR SECTIONS 1/8" THRU 4" DIAMETER ARE A120 AND 5" AND LARGER ARE A53 Gr.B. ALL FLAT SECTIONS ARE A283 GR.D.

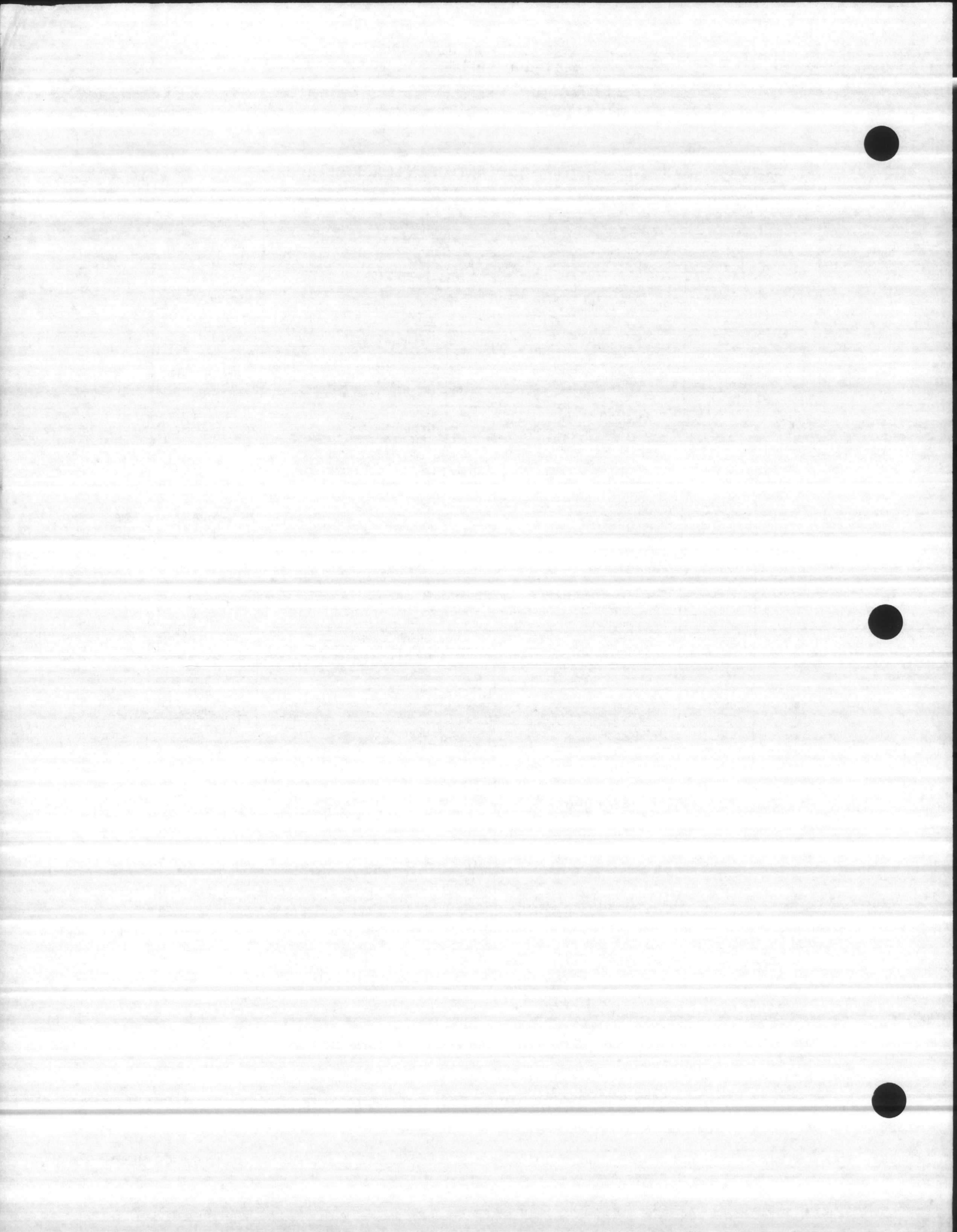

**VERTICAL TURBINE PUMPS  
MATERIAL SPECIFICATIONS**

**24LYA2363AX — FLANGED COLUMN AND OPEN LINESHAFT**

Reference Number	Part Name	Material	Specification (1)
21	Top Column & Flange	Steel	See Note 2
23	Lineshaft	Steel	AISI 1045
25	Bearing Retainer	Bronze	B584 Alloy 836
26	Bearing	Rubber	Neoprene
29	Lineshaft Sleeve	Stainless Steel	AISI 304
30	Bottom Column & Flange	Steel	See Note 2
31	Shaft Coupling	Steel	A108 GR 12L14
32	Pump Shaft	Stainless Steel	A582-416
50	Connector Bearing	Bronze	B505 Alloy 932

**24LYA2363BB — FLANGED COLUMN AND ENCLOSED LINESHAFT**

Reference Number	Part Name	Material	Specification (1)
21	Top Column & Flange	Steel	See Note 2
23	Lineshaft	Steel	AISI 1045
30	Bottom Column & Flange	Steel	See Note 2
31	Shaft Coupling	Steel	A108 GR 12L14
32	Pump Shaft	Stainless Steel	A582-416
50	Connector Bearing	Bronze	B505 Alloy 932
51	Bottom Enclosing Tube	Steel	See Note 2
51A	Enclosing Tube	Steel	See Note 2
53	Step Connector Bearing	Bronze	B505 Alloy 932
65	Tube Stabilizer	Rubber	Natural

NOTE: 1. ALL MATERIAL SPECIFICATIONS ARE ASTM UNLESS OTHERWISE NOTED AND ARE FOR DESCRIPTION OF CHEMISTRY ONLY.

NOTE: 2. ALL CIRCULAR SECTIONS 1/8" THRU 4" DIAMETER ARE A120 AND 5" AND LARGER ARE A53 Gr.B. ALL FLAT SECTIONS ARE A283 GR.D.



DRAWN BY DENNIS E. DYE  
 DATE 1-29-85  
 CHECKED BY *MD*  
 DATE 7-85  
 ENGINEERING APPROVAL *MD*  
 DATE 6/85  
 MARKETING APPROVAL *DR*  
 DATE 6/85  
 DRAWING NUMBER 24LYA2363

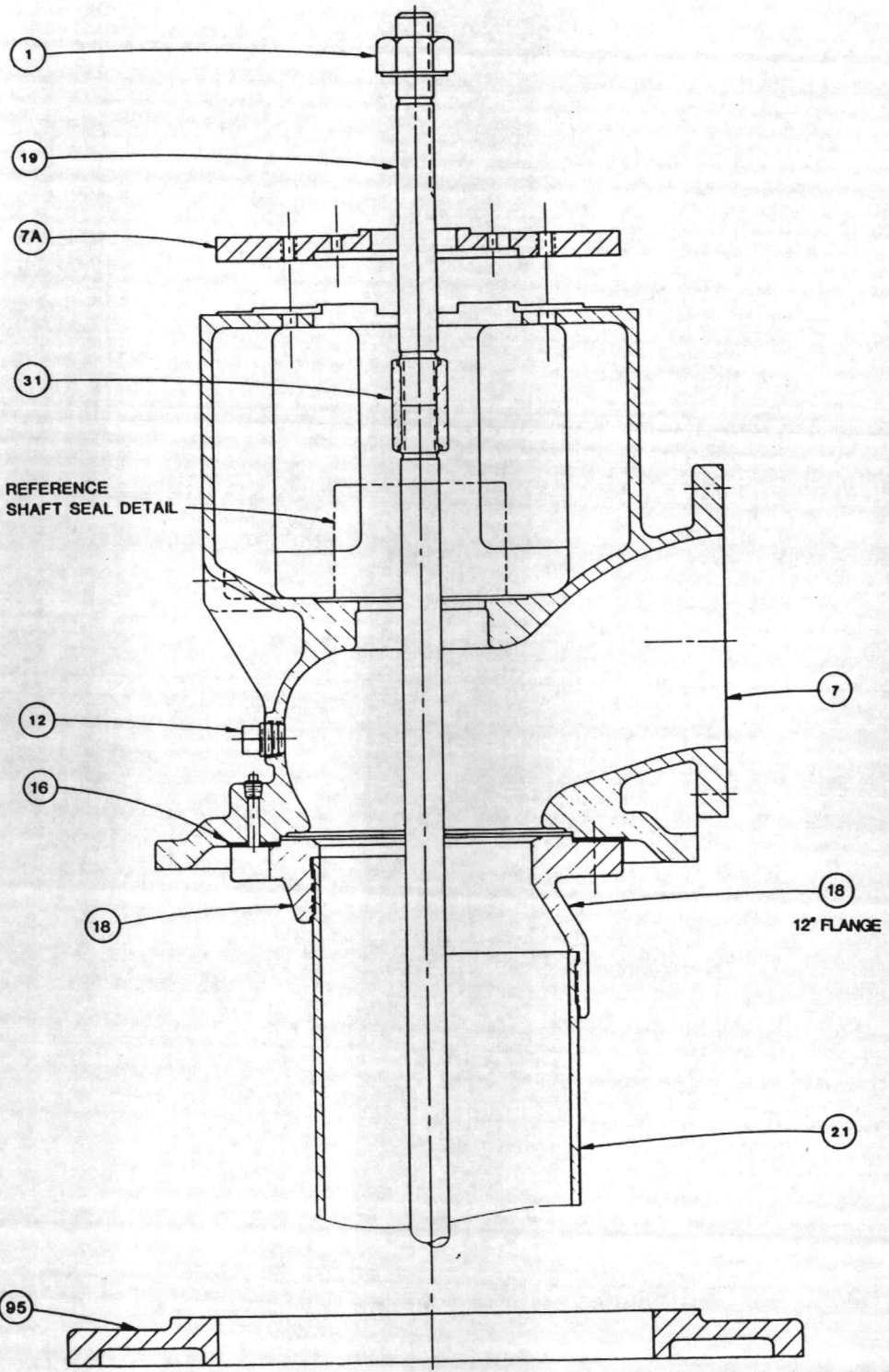

ER2-12164

Fairbanks Morse Pump Corporation

ASSEMBLY  
D STYLE  
DISCHARGE HEAD

SIZE C DWG. NO. 24LYA2363BL

REV.	DATE	ECN NO.
1	2/1/86	EC2-13179

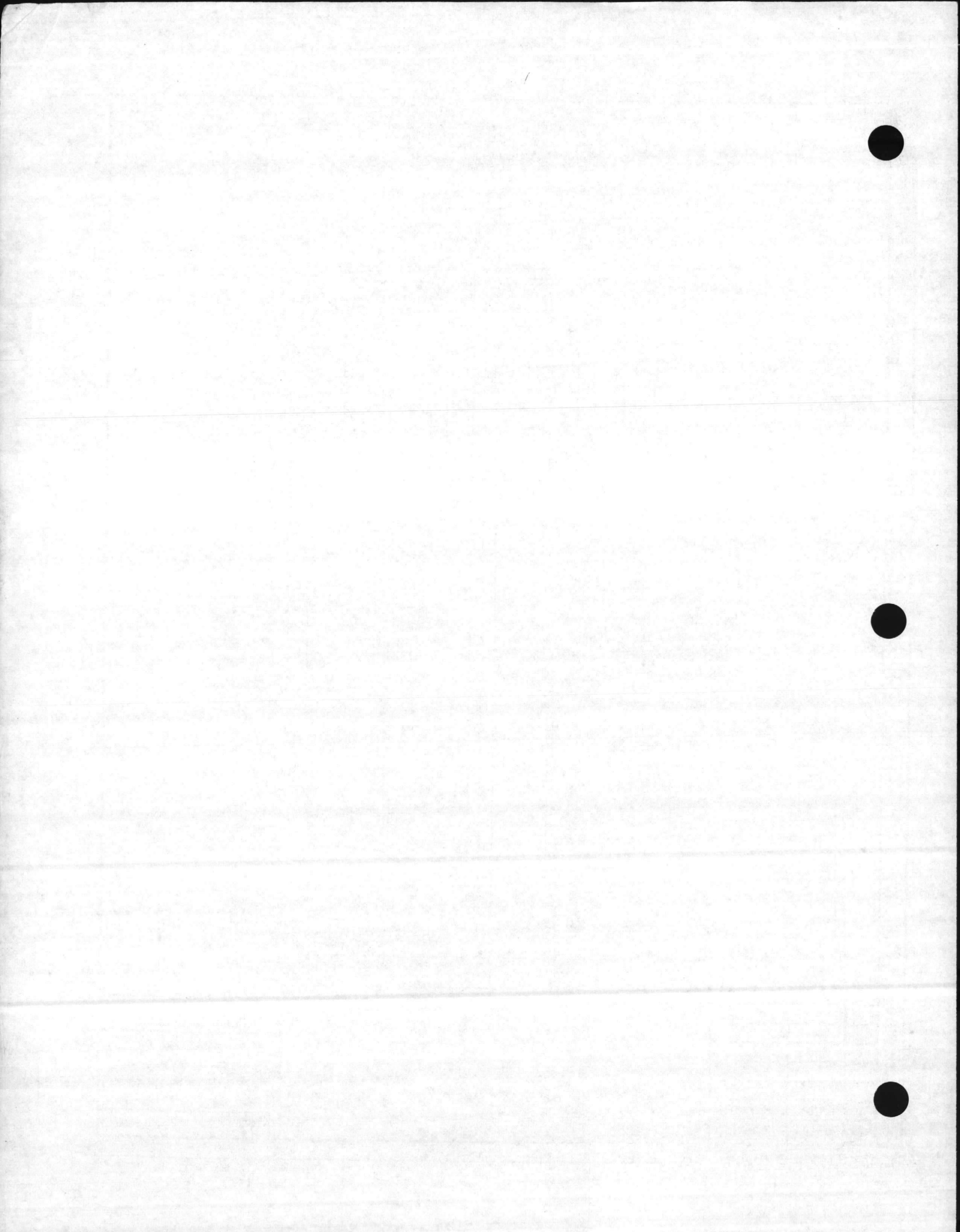

DRAW BY  
 DATE 12-83  
 CHECKED BY  
 DATE 2/83  
 ENGINEERING APPROVAL  
 DATE  
 MARKETING APPROVAL  
 DATE  
 DRAWING NUMBER 24LYA2363BV

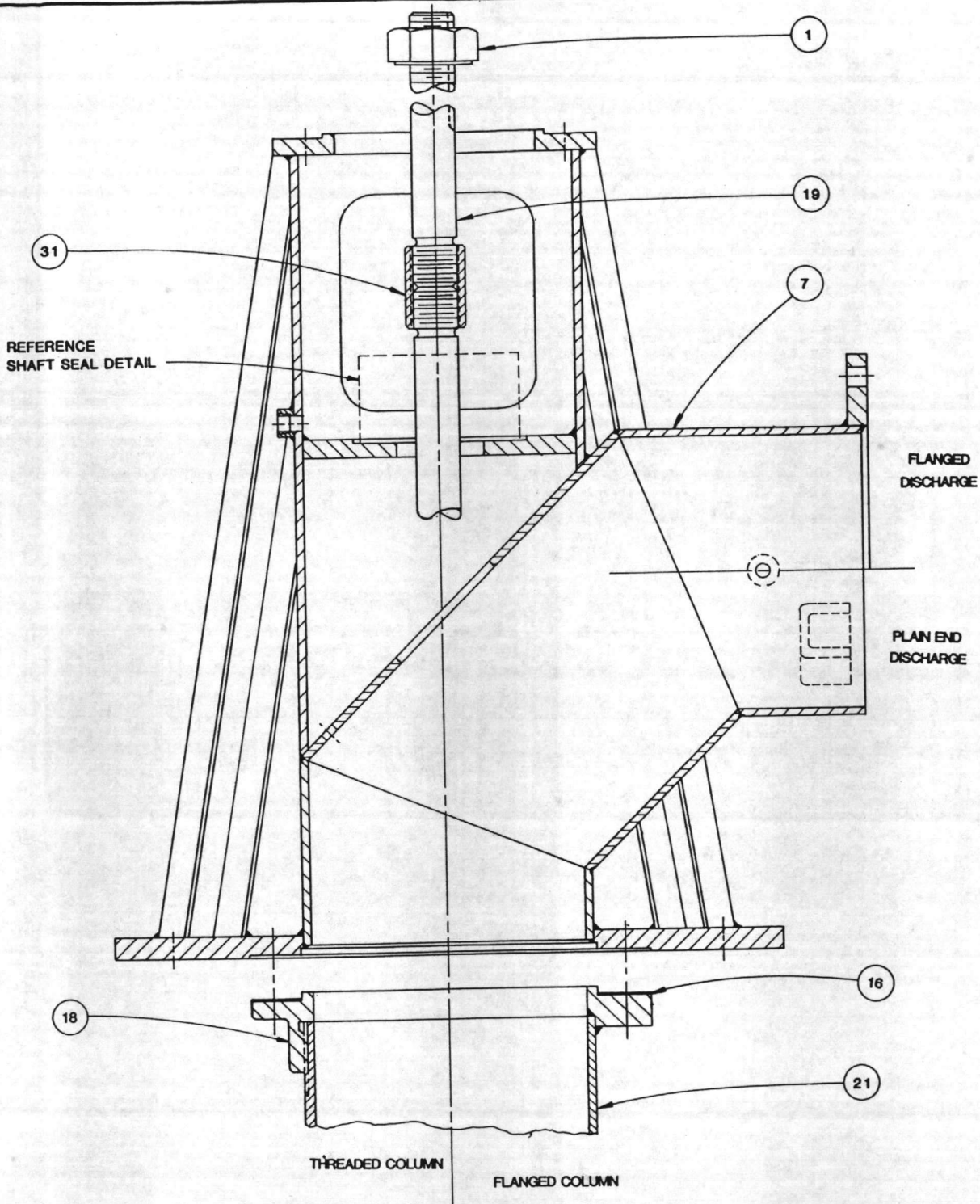

ER2-12164

Fairbanks Morse Pump Corporation

**ASSEMBLY  
 "F"  
 FABRICATED  
 DISCHARGE HEAD**

SIZE C DWG. NO. 24LYA2363BV

REV.	DATE	ECN NO.
1	2/1/86	EC2-13179





DRAWN DENNIS E. DYE  
 DATE 1-24-85  
 CHECKED BY *W.S.*  
 DATE 1-85  
 ENGINEERING APPROVAL  
 DATE  
 MARKETING APPROVAL  
 DATE  
 DRAWING NUMBER 24LYA2363BP

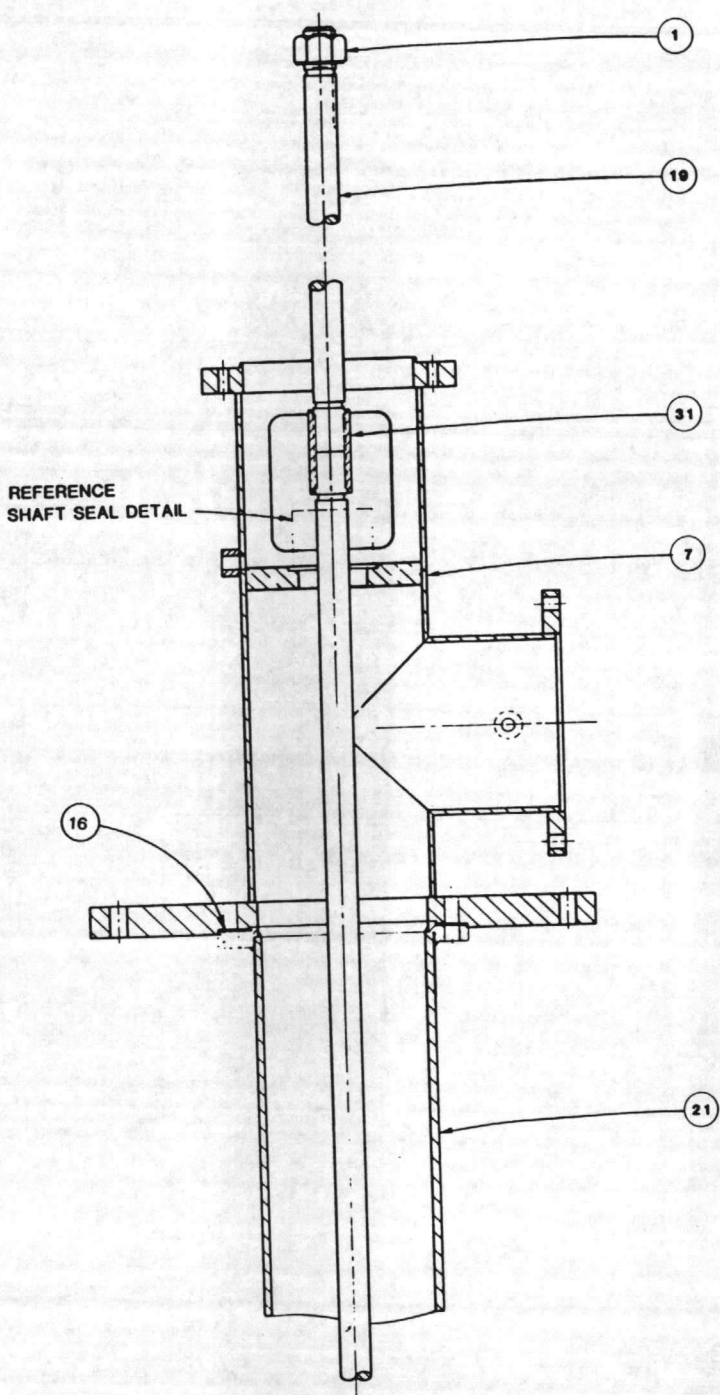

REV.	DATE	ECN NO.
1	2/1/86	EC2-13179

ER2-12164

Fairbanks Morse  
 Pump Corporation

**ASSEMBLY  
 L & LS STYLE  
 DISCHARGE HEAD**

SIZE C DWG. NO. 24LYA2363BP



DRAWN BY [Redacted]  
 REJ [Redacted]  
 DATE 12-83  
 CHECKED BY *Norman S. [Redacted]*  
 DATE 12-83  
 ENGINEERING APPROVAL [Redacted]  
 DATE [Redacted]  
 MARKETING APPROVAL [Redacted]  
 DATE [Redacted]  
 DRAWING NUMBER 24LYA2363BC

REFERENCE SHAFT SEAL DETAIL

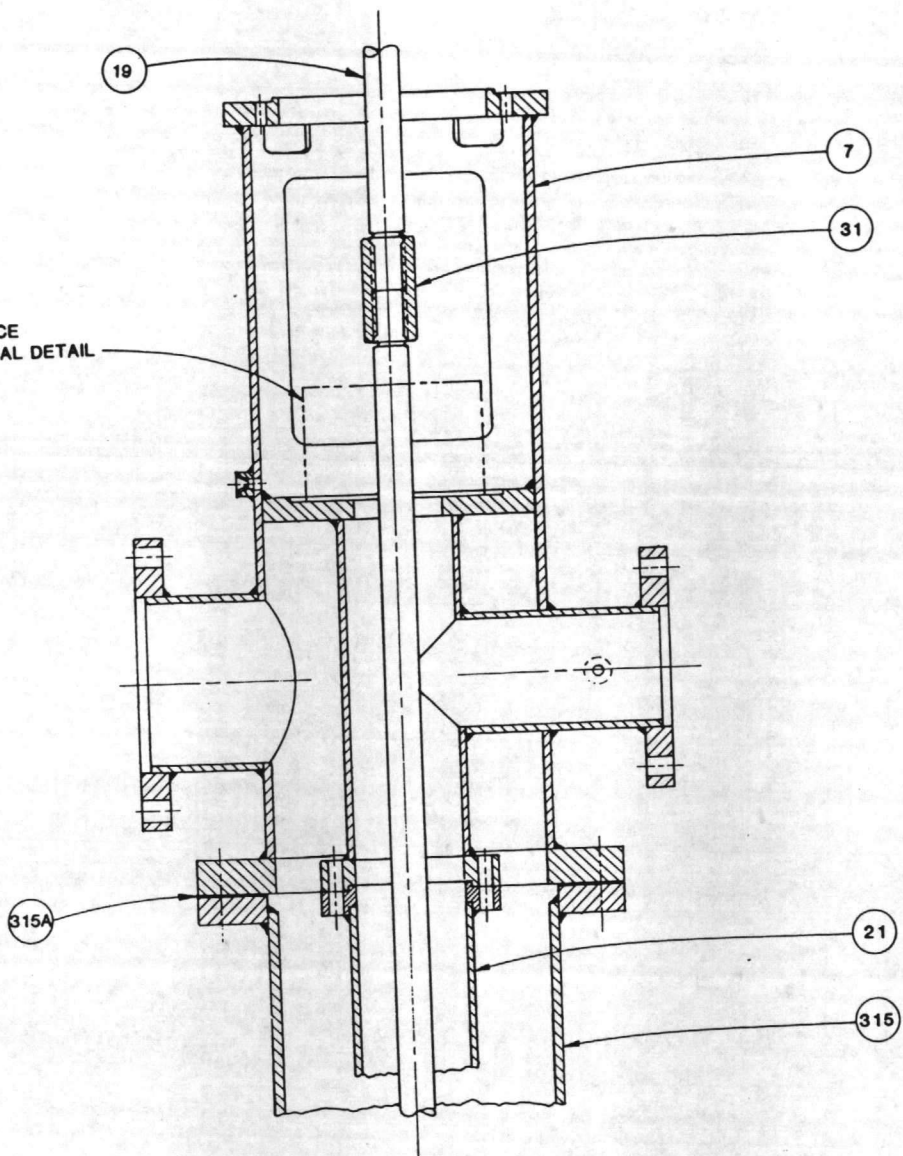

ER2-12164

Fairbanks Morse  
Pump Corporation

ASSEMBLY  
T-DISCHARGE HEAD

SIZE C DWG. NO. 24LYA2363BC

REV.	DATE	ECN NO.
1	2/1/86	EC2-13179

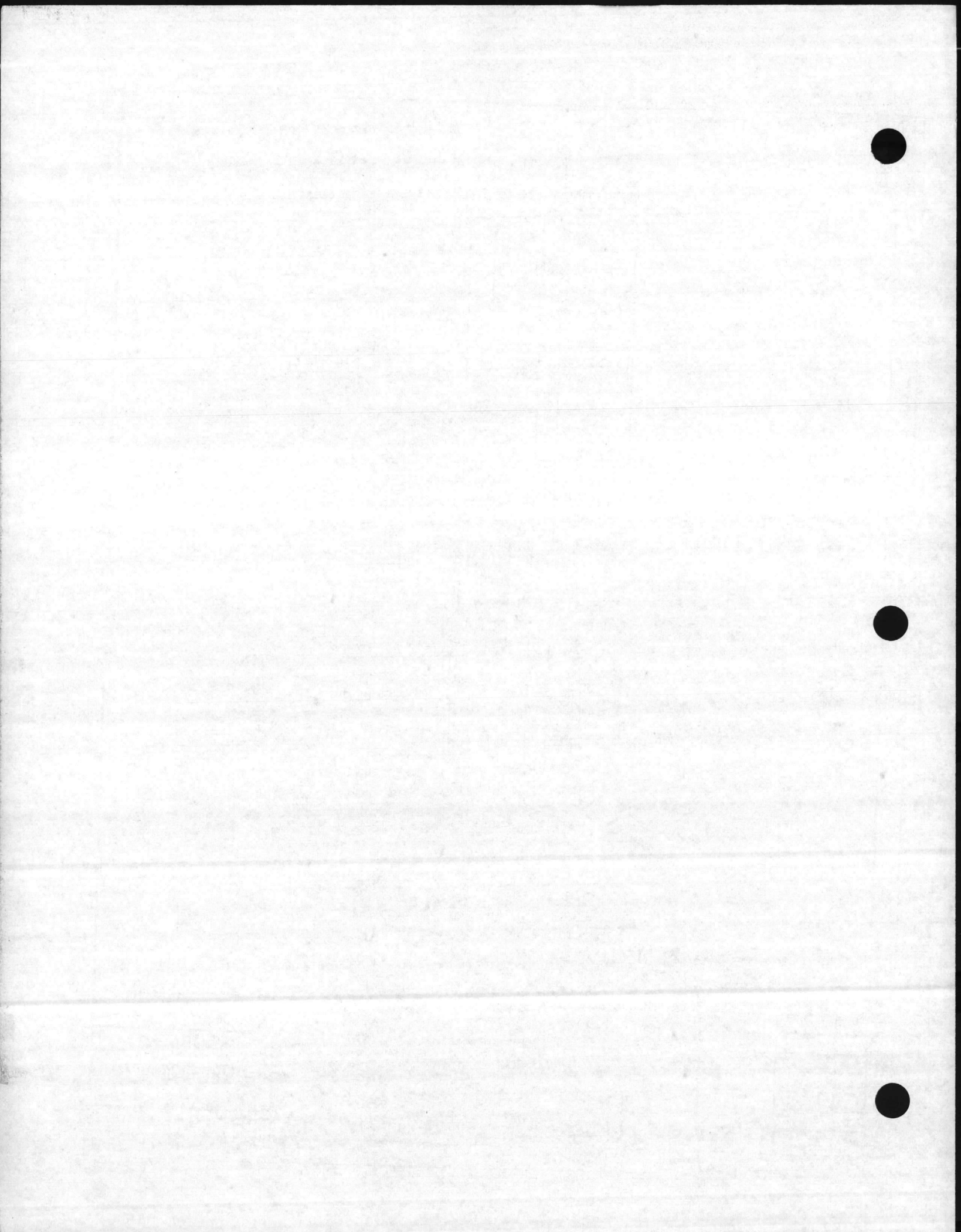

**VERTICAL TURBINE PUMPS  
MATERIAL SPECIFICATIONS  
DISCHARGE HEADS**

**C, CT, D AND H DISCHARGE HEADS**

Reference Number	Part Name	Material	Specification
1	Top Shaft Adjusting Nut	Steel	A108 GR 12L14
7	Discharge Head	Cast Iron	A48 Class 30
7A	Motor Adaptor Plate	Steel	A283 GR D
12	Prelubrication Pipe Pug	Cast Iron	Commercial
16	Column Flange Gasket	Tag Board	D1170 GR 3111
18	Column Flange	Cast Iron	A48 Class 30
19	Top Shaft	Steel	AISI 1045
21	Top Column	Steel	See Note 2
31	Shaft Coupling	Steel	A108 GR 12L14
95	Foundation Plate	Cast Iron	A48 Class 30
None	Column Flange Capscrew	Steel	SAE J429 Gr 2
None	Air Vent Plug	Cast Iron	Commercial

Reference: Assembly Drawings 24LYA2363BM, 24LYA2363BN, 24LYA2363BL and 24LYA2363BF

**F, LS, LS AND T DISCHARGE HEADS**

Reference Number	Part Name	Material	Specification
1	Top Shaft Adjusting Nut	Steel	A108 GR 12L14
7	Discharge Head	Steel	See Note 2
16	Column Flange Gasket	Tag Board	D1170 GR 3111
18	Column Flange	Cast Iron	A48 Class 30
19	Top Shaft	Steel	AISI 1045
21	Top Column	Steel	See Note 2
31	Shaft Coupling	Steel	A108 GR 12L14
315A	Suction Pot Gasket	Tagboard	D1170 GR 3111
None	Column Flange Capscrew	Steel	SAE J429 Gr 2

Reference: Assembly Drawings 24LYA2363BP, 24LYA2363BV, and 24LYA2363BC.

**UF AND UG UNDERGROUND DISCHARGE HEADS**

Reference Number	Part Name	Material	Specification
1	Top Shaft Adjusting Nut	Steel	A108 GR 12L14
16	Column Flange Gasket	Tag Board	D1170 GR 3111
19	Top Shaft	Steel	AISI 1045
31	Shaft Coupling	Steel	A108 GR 12L14
52	U.G. Discharge Elbow	Steel	See Note 2
62	Motor Pedestal	Steel or Cast Iron	See Note 3
None	Column Flange Capscrew	Steel	SAE J429 Gr 2

Reference: Assembly Drawings 24LYA2363BH and 24LYA2363BJ

- NOTE: 1. ALL MATERIAL SPECIFICATIONS ARE ASTM UNLESS OTHERWISE NOTED AND ARE FOR DESCRIPTION OF CHEMISTRY ONLY.
- NOTE: 2. ALL CIRCULAR SECTIONS 1/8" THRU 4" ARE A120, and 5" AND LARGER ARE A53 GR.B. ALL FLAT SECTIONS ARE A283 GR. D.
- NOTE: 3. MOTOR PEDESTAL WILL BE CAST IRON A48 CLASS 30, OR STEEL PER NOTE: 2 ABOVE, AT MANUFACTURER'S OPTION.



DRAWN BY  
 REC'D  
 DATE 5-6-85  
 CHECKED BY JCS  
 DATE  
 ENGINEERING APPROVAL  
 DATE  
 MARKETING APPROVAL  
 DATE 9/85  
 DRAWING NUMBER 25LYA3463B

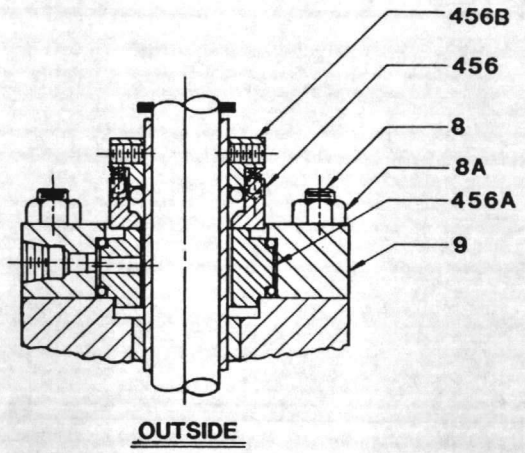

OUTSIDE

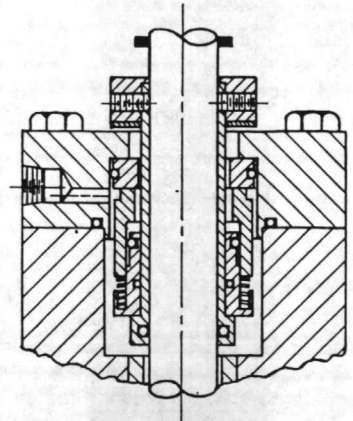

CARTRIDGE

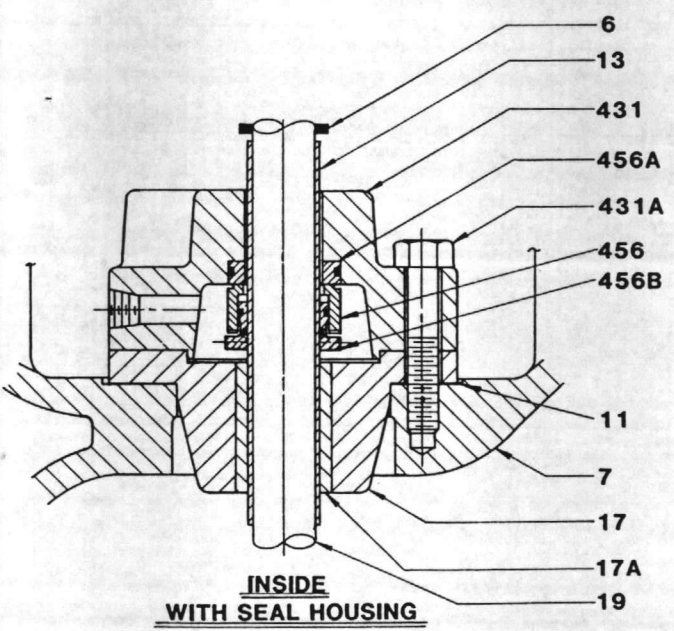

INSIDE WITH SEAL HOUSING

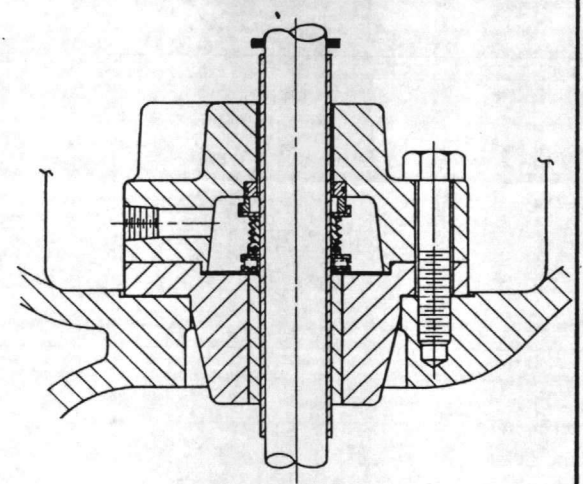

METAL BELLOWS WITH SEAL HOUSING

NOTE 1: ALL SEAL TYPES USE SAME COMPONENTS AS \*INSIDE WITH SEAL HOUSING\* EXCEPT AS NOTED.  
 NOTE 2: AVAILABLE IN SLEEVED OR FLUSH SHAFT ARRANGEMENTS FOR MOST APPLICATIONS.  
 NOTE 3: REFERENCE DRAWING 25LYA3463 FOR OPTIONAL SEALING ARRANGEMENTS.

ER2-12874

1	2/1/86	EC2-13179
REV.	DATE	ECN NO.

Fairbanks Morse Pump Corporation	
<b>MECHANICAL SEAL TYPES</b>	
SIZE C	DWG. NO. 25LYA3463B





**VERTICAL TURBINE PUMPS  
MATERIAL SPECIFICATIONS  
MECHANICAL SEALS**

250

Reference Number	Part Name	Material	Specification
6	Water Slinger	Rubber	Neoprene
7	Discharge Head	Cast Iron	ASTM A48 Class 30
8	Gland Bolt	Stainless Steel	18-8
8A	Gland Nut	Stainless Steel	18-8
9	Packing Box Gland	Cast Iron	ASTM A48 Class 30
11	Packing Box Gasket	Tag Board	ASTM D1170 GRADE 3111
13	Top Shaft Sleeve	Stainless Steel	AISI 304
15	Packing	Graphited Synthetic	Commercial
17	Packing Box	Cast Iron	ASTM A48 Class 30
17A	Packing Box Bushing	Bronze	ASTM B505 Alloy 932
17B	Throttle Bushing	Carbon	Commercial
19	Top Shaft	Steel	AISI 1045
None	Gland Nut Lockwasher	Steel	Commercial
431A	Packing Box Capscrews	Steel	SAE J429 GRADE 2
431	Mechanical Seal Gland	Cast Iron	ASTM A48 Class 30
431B	Lip Seal	Commercial	Commercial
456	Rotating Seat	As Required	As Required
456A	Stationary Seat	As Required	As Required
456B	Retainer	As Required	As Required

Reference: Assembly Drawings 25LYA3463 and 25LYA3463B.



DRAWN BY RCT  
 DATE 5-2-85  
 CHECKED BY JS  
 DATE  
 ENGINEERING APPROVAL WMB  
 DATE 8/85  
 MARKETING APPROVAL DK  
 DATE 9/85  
 DRAWING NUMBER 25LYA2918L

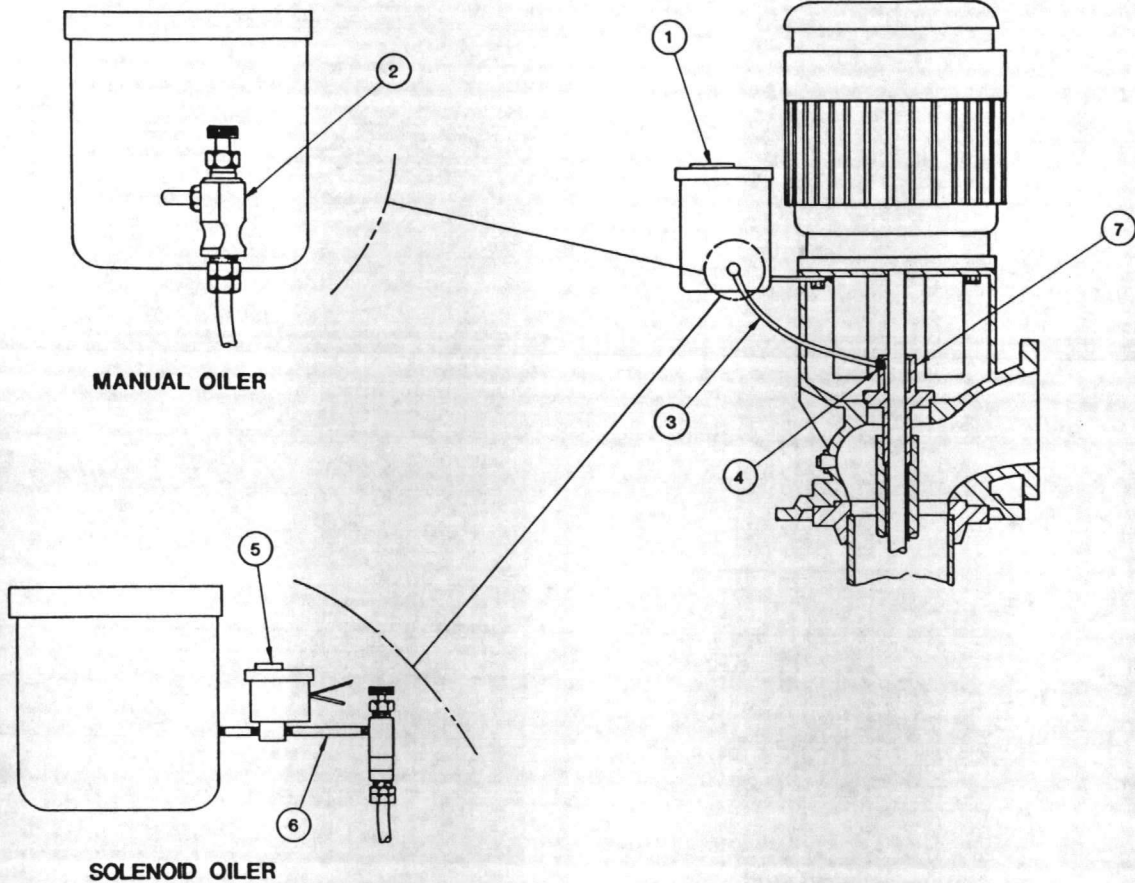

BILL OF MATERIAL LIST			
REF.	DESCRIPTION	MATERIAL	SPECIFICATION
1	OILER, RESERVOIR, & BRKT.	ALUMINUM	COMMERCIAL
2	OIL DRIPPER ASSY. 1/8"	PURCHASED	COMMERCIAL
3	COPPER TUBING 1/4" x 24" LG.	COPPER	ASTM B280
4	COMPRESSION FITTING 1/4"	BRASS	COMMERCIAL
5	SOLENOID VALVE (NOTE 1)	PURCHASED	COMMERCIAL
6	PIPE NIPPLE 1/8" x 3/4" LG.	STEEL	ASTM A120.
7	PIPE PLUG 1/4"	MALLEABLE IRON	COMMERCIAL

NOTE 1: VOLTAGE AS REQUIRED.

ER2-12874

1	2/1/86	EC2-13179
REV.	DATE	ECN NO.

Fairbanks Morse Pump Corporation	
VERTICAL TURBINE LINESHAFT OILER ASSEMBLIES	
SIZE C	DWG. NO. 25LYA2918L



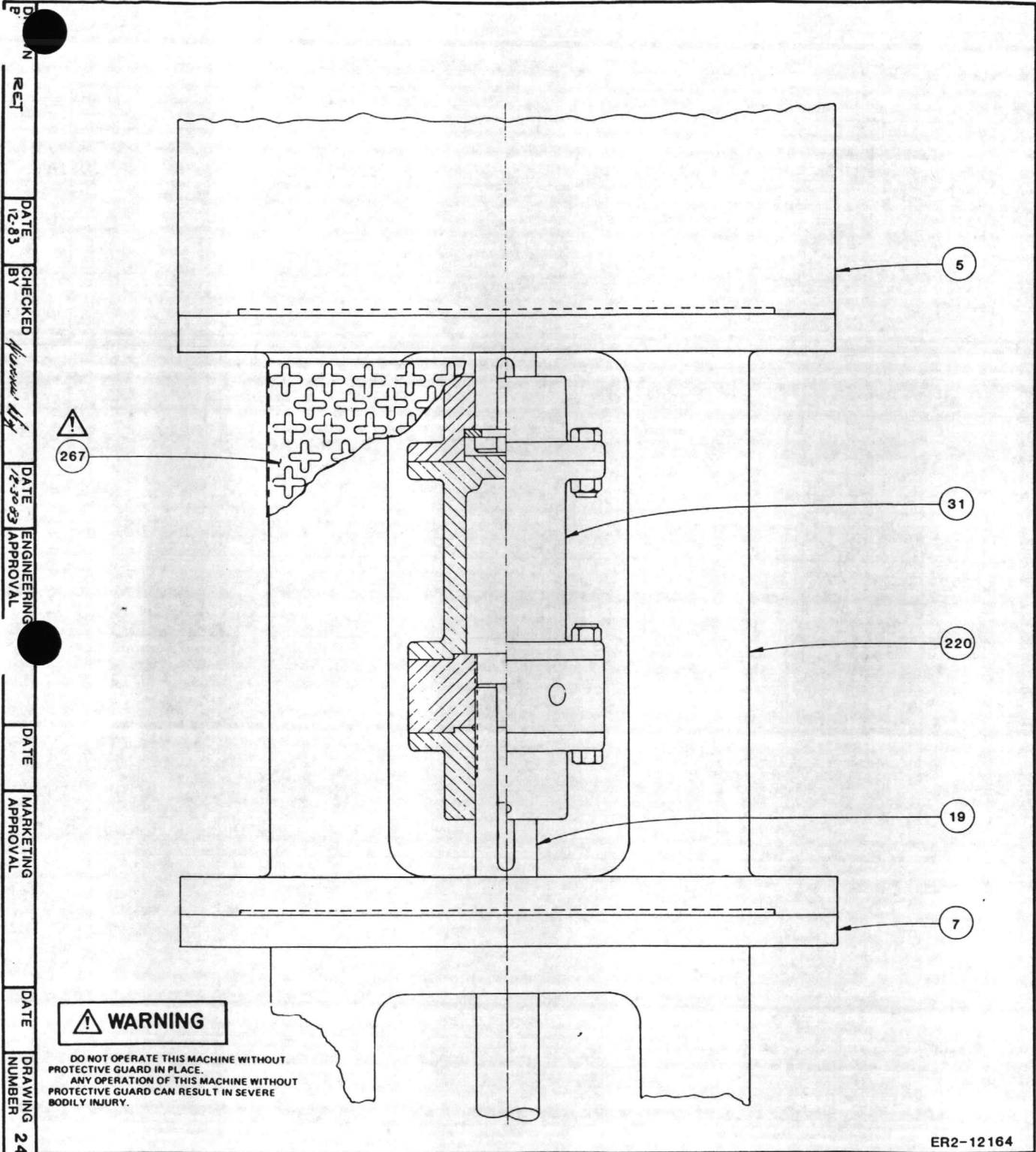

DRAWING NUMBER 24LYA2363  
 DATE 12-83  
 CHECKED BY *M. J. ...*  
 DATE 12-83  
 ENGINEERING APPROVAL  
 DATE  
 MARKETING APPROVAL  
 DATE  
 REV. DATE ECN NO.

**WARNING**

DO NOT OPERATE THIS MACHINE WITHOUT PROTECTIVE GUARD IN PLACE. ANY OPERATION OF THIS MACHINE WITHOUT PROTECTIVE GUARD CAN RESULT IN SEVERE BODILY INJURY.

ER2-12164

Fairbanks Morse  
 Pump Corporation  
**ASSEMBLY  
 SPACER COUPLING  
 &  
 HIGH RING BASE**

SIZE DWG. NO. **24LYA2363AW**  
**C**



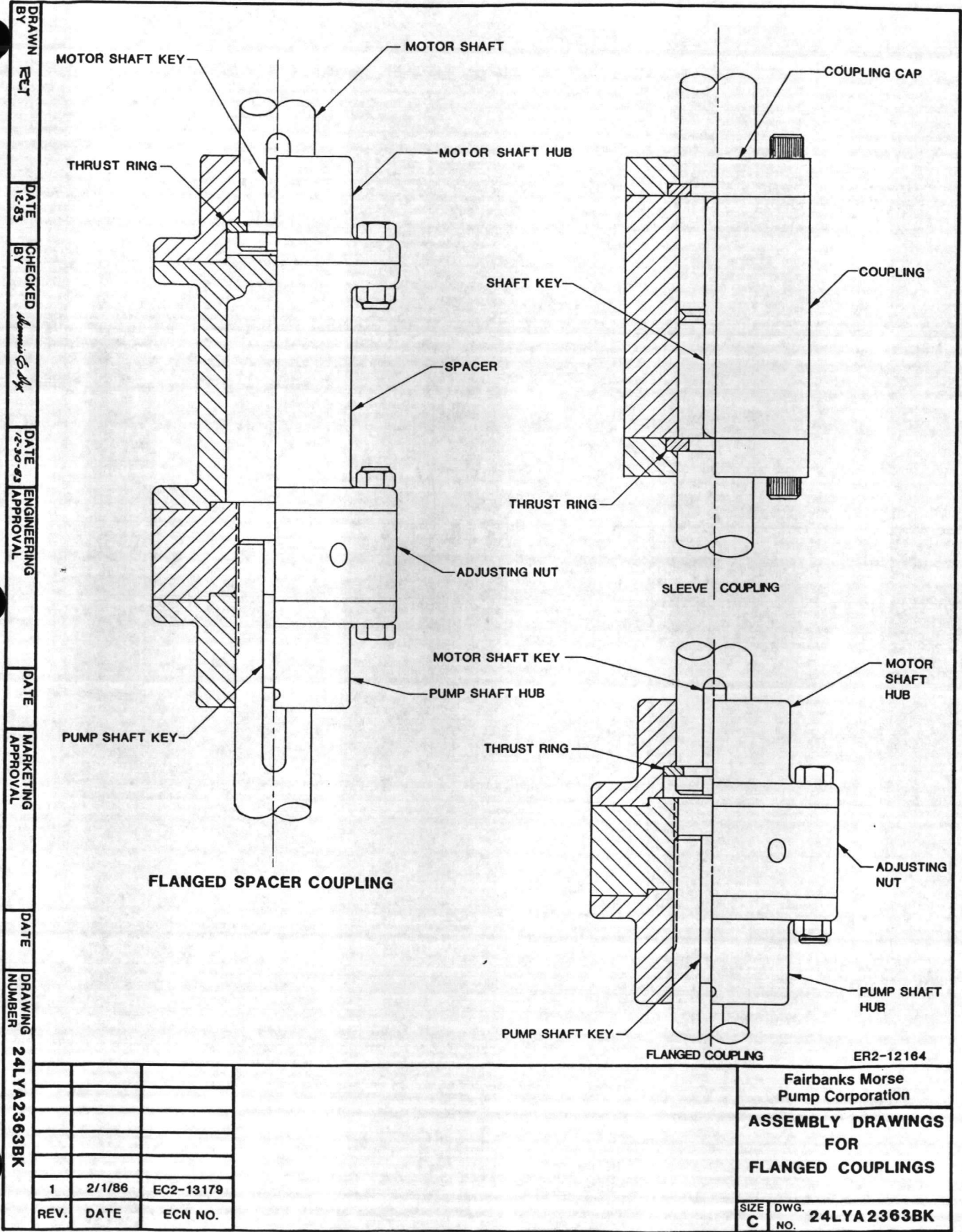

DRAWN BY	ECT	DATE	CHECKED BY	DATE	ENGINEERING APPROVAL	DATE	MARKETING APPROVAL	DATE	DRAWING NUMBER
		12-83	<i>Alvin S. Dyk</i>	12-30-83					24LYA2363BK

REV.	DATE	ECN NO.
1	2/1/86	EC2-13179

ER2-12164

Fairbanks Morse  
Pump Corporation

**ASSEMBLY DRAWINGS  
FOR  
FLANGED COUPLINGS**

SIZE **C** DWG. NO. **24LYA2363BK**





DRAWN: *Amos, S. J.*  
 DATE: 9-15-81  
 CHECKED BY: *R*  
 DATE: 10/8/81  
 ENGINEERING APPROVAL: *R*  
 DATE: 1/85  
 MARKETING APPROVAL: *R*  
 DATE: 1/85  
 DRAWING NUMBER: 24LYA2366B

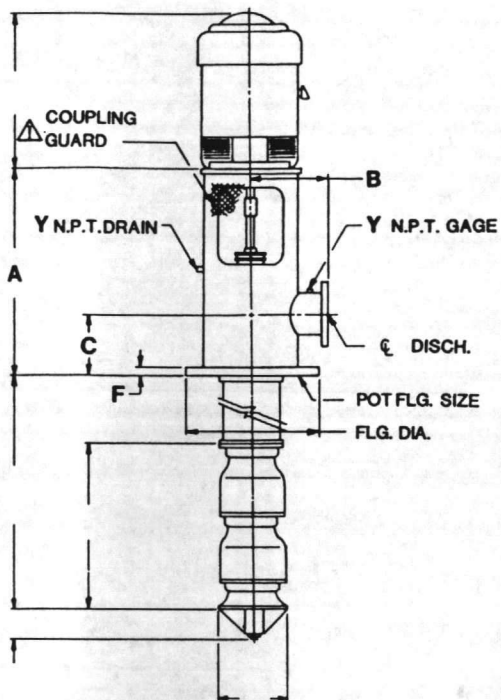

150 # FLANGE DIMENSIONS					
NOM. SIZE	FLG. DIA.	FLG. THK.	NO. OF BOLTS	BOLT DIA.	BOLT CIRC.
4	9	1	8	5/8	7-1/2
6	11	1	8	3/4	9-1/2
8	13-1/2	1-1/8	8	3/4	11-3/4
10	16	1-1/4	12	7/8	14-1/4
12	19	1-1/4	12	7/8	17
14	21	1-3/8	12	1	18-3/4
16	23-1/2	1-1/2	16	1	21-1/4
20	N/A	N/A	20	1-1/8	25
24	N/A	N/A	20	1-1/4	29-1/2
30	N/A	N/A	28	1-1/4	36
36	N/A	N/A	32	1-1/2	42-3/4

300 # FLANGE DIMENSIONS					
NOM. SIZE	FLG. DIA.	FLG. THK.	NO. OF BOLTS	BOLT DIA.	BOLT CIRC.
4	10	1-1/4	8	3/4	7-7/8
6	12-1/2	1-7/16	12	3/4	10-5/8
8	15	1-5/8	12	7/8	13
10	17-1/2	1-7/8	16	1	15-1/4
12	20-1/2	2	16	1-1/8	17-3/4
14	23	2-1/8	20	1-1/8	20-1/4

HEAD SIZE	POT FLG. SIZE	FLG. DIA.	A	B	C	F	Y
12 X 4	10	16	28-1/2	10-7/8	7	1-1/4	1/2
16-1/2 X 6	10	16	32-1/8	10-7/8	8	1-1/4	1/2
16-1/2 X 6	14	21	32-1/8	12-7/8	8	1-1/4	1/2
16-1/2 X 8	16	23-1/2	37	14-3/8	11	1-3/8	3/4
20 X 10	20	27-1/2	41-1/4	16-7/8	12	1-5/8	1
20 X 10	24	32	50-3/4	15	12	1-7/8	1
20 X 12	24	32	47-3/4	19-1/8	14	1-7/8	1
24-1/2 X 14	30	38-7/8	48-1/2	22-3/8	14	1-7/8	1
24-1/2 X 14	24	32	48-1/2	19-1/8	14	1-7/8	1

NOTE: 1. ALL FLANGES ARE 150 # STANDARD, OPTIONAL DISCHARGE FLANGE IS 300 #.  
 2. POT FLANGE IS 150 # EXCEPT DIAMETER AND THICKNESS.



**WARNING**

DO NOT OPERATE THIS MACHINE WITHOUT PROTECTIVE GUARD IN PLACE. ANY OPERATION OF THIS MACHINE WITHOUT PROTECTIVE GUARD CAN RESULT IN SEVERE BODILY INJURY.

CUSTOMER		P.O.		Fairbanks Morse Pump Corporation	
JOB NAME					
PUMP SIZE & MODEL	STAGES	GPM	TDH	RPM	ROT C.C.W.
MOTOR	HP	FRAME	PHASE	HERTZ	VOLTS ENCL
1	9/14/81	EC210695	CERTIFIED FOR		DATE
REV.	DATE	ECN NO.	CERTIFIED BY		DATE

FAIRBANKS MORSE PUMPS

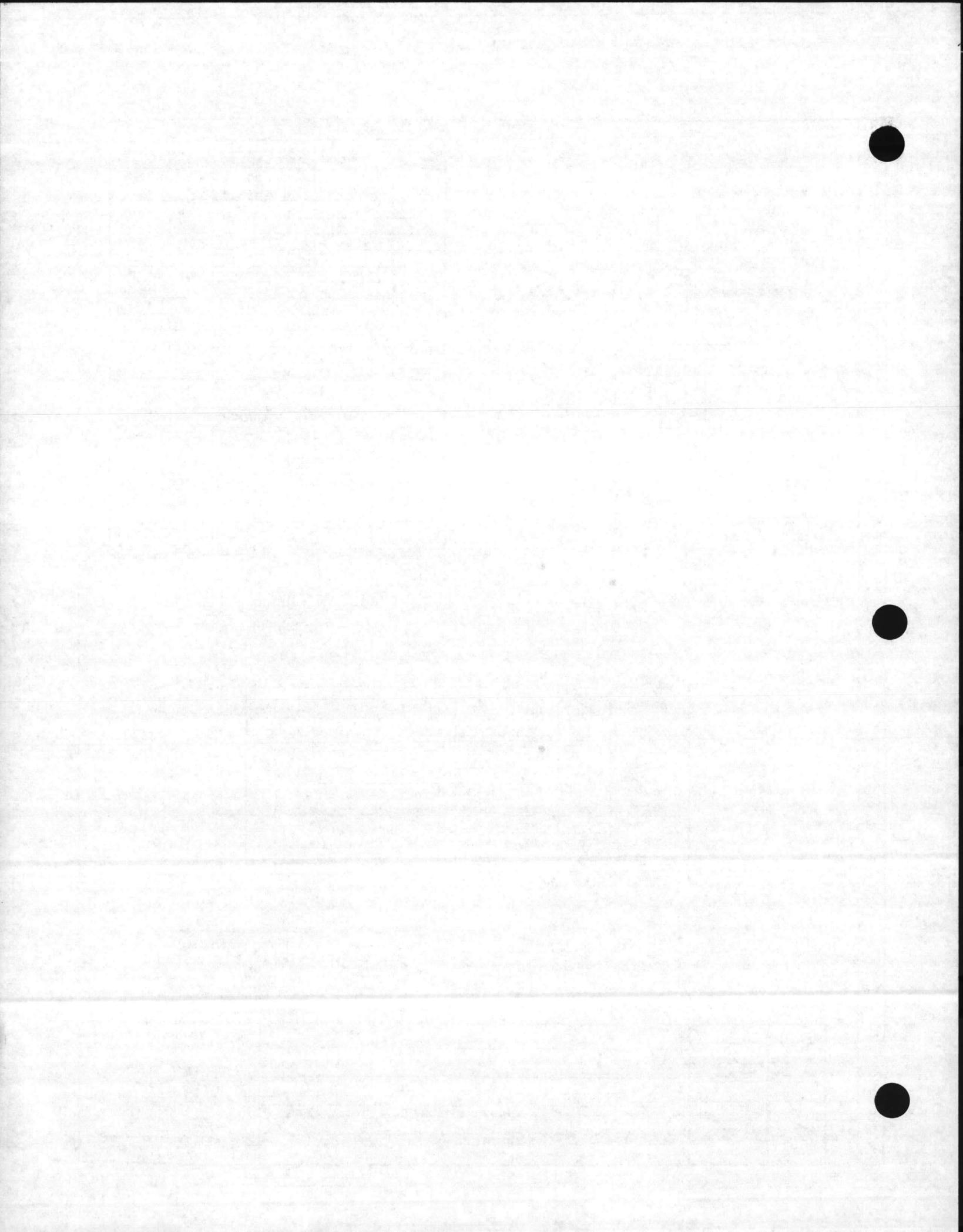

DATE 9-15-81 BY [Signature] CHECKED [Signature] DATE 10/8/81 ENGINEERING APPROVAL [Signature] DATE 6/8/85 MARKETING APPROVAL [Signature] DATE 6/8/85 DRAWING NUMBER 24LYA23

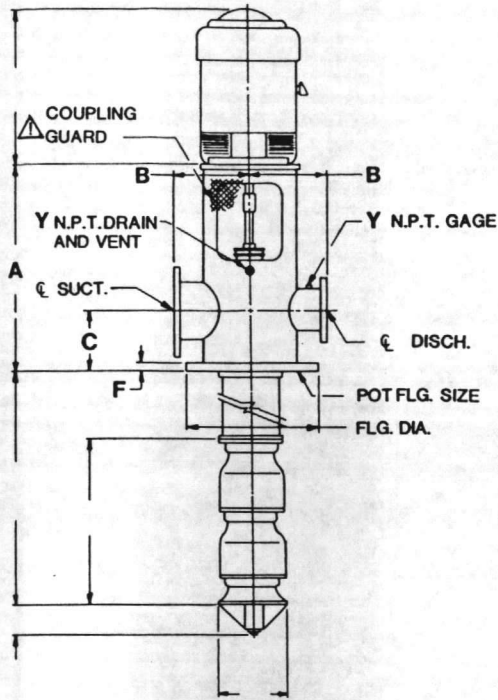

NOM. SIZE	FLG. DIA.	FLG. THK.	NO. OF BOLTS	BOLT DIA.	BOLT CIRC.
4	9	1	8	5/8	7-1/2
6	11	1	8	3/4	9-1/2
8	13-1/2	1-1/8	8	3/4	11-3/4
10	16	1-1/4	12	7/8	14-1/4
12	19	1-1/4	12	7/8	17
14	21	1-3/8	12	1	18-3/4
16	23-1/2	1-1/2	16	1	21-1/4
20	N/A	N/A	20	1-1/8	25
24	N/A	N/A	20	1-1/4	29-1/2
30	N/A	N/A	28	1-1/4	36
36	N/A	N/A	32	1-1/2	42-3/4

NOM. SIZE	FLG. DIA.	FLG. THK.	NO. OF BOLTS	BOLT DIA.	BOLT CIRC.
4	10	1-1/4	8	3/4	7-7/8
6	12-1/2	1-7/16	12	3/4	10-5/8
8	15	1-5/8	12	7/8	13
10	17-1/2	1-7/8	16	1	15-1/4
12	20-1/2	2	16	1-1/8	17-3/4
14	23	2-1/8	20	1-1/8	20-1/4

HEAD SIZE	POT FLG. SIZE	FLG. DIA.	A	B	C	F	Y
12 X 4 X 6	10	16	32-3/4	10	9	1-1/4	1/2
16-1/2 X 6 X 8	14	21	36-1/8	13	9	1-3/8	1/2
20 X 8 X 10	16	23-1/2	38	14-1/2	10-1/2	1-1/2	3/4
20 X 8 X 10	20	27-1/2	38	16	10-1/2	1-3/4	3/4
20 X 10 X 12	20	27-1/2	44	16	13	1-3/4	1
24-1/2 X 12 X 14	24	32	49	19	14	1-7/8	1
24-1/2 X 14 X 16	30	38-7/8	53	22	16	1-7/8	1
24-1/2 X 14 X 16	36	46	53	25	16	1-7/8	1

- NOTE: 1. ALL FLANGES ARE 150 # STANDARD, OPTIONAL DISCHARGE FLANGE IS 300 #.  
 2. POT FLANGE IS 150 # EXCEPT DIAMETER AND THICKNESS.  
 3. DISCH. HEAD SIZE IS LISTED BY MOTOR BD X DISCH. X SUCT.



DO NOT OPERATE THIS MACHINE WITHOUT PROTECTIVE GUARD IN PLACE. ANY OPERATION OF THIS MACHINE WITHOUT PROTECTIVE GUARD CAN RESULT IN SEVERE BODILY INJURY.

CUSTOMER		P.O.		Fairbanks Morse Pump Corporation	
JOB NAME					
PUMP SIZE & MODEL	STAGES	GPM	TDH	RPM	ROT CCW.
MOTOR	HP	FRAME	PHASE	HERTZ	VOLTS ENCL
1	9/14/81	EC210695	CERTIFIED FOR		CERTIFIED BY
REV.	DATE	ECN NO.	DATE		SIZE C DWG. NO. 24LYA2366A

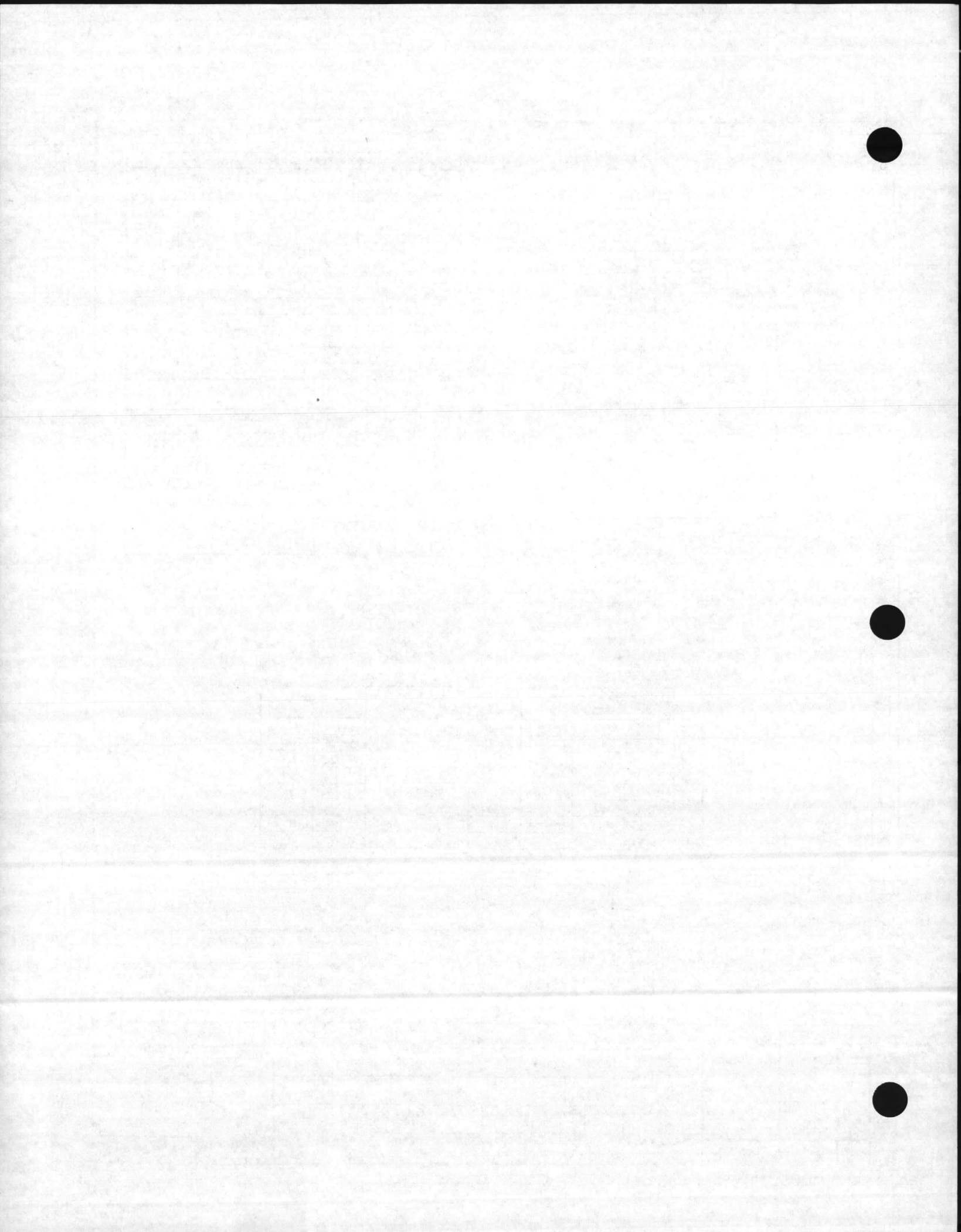

DRAWN BY: *Thomas De Rye* DATE: 9/16/81 CHECKED BY: *WJF* DATE: 12/2/81 ENGINEERING APPROVAL: DATE: 9/85 MARKETING APPROVAL: DATE: 9/85 DRAWING NUMBER: 24LYA2366D

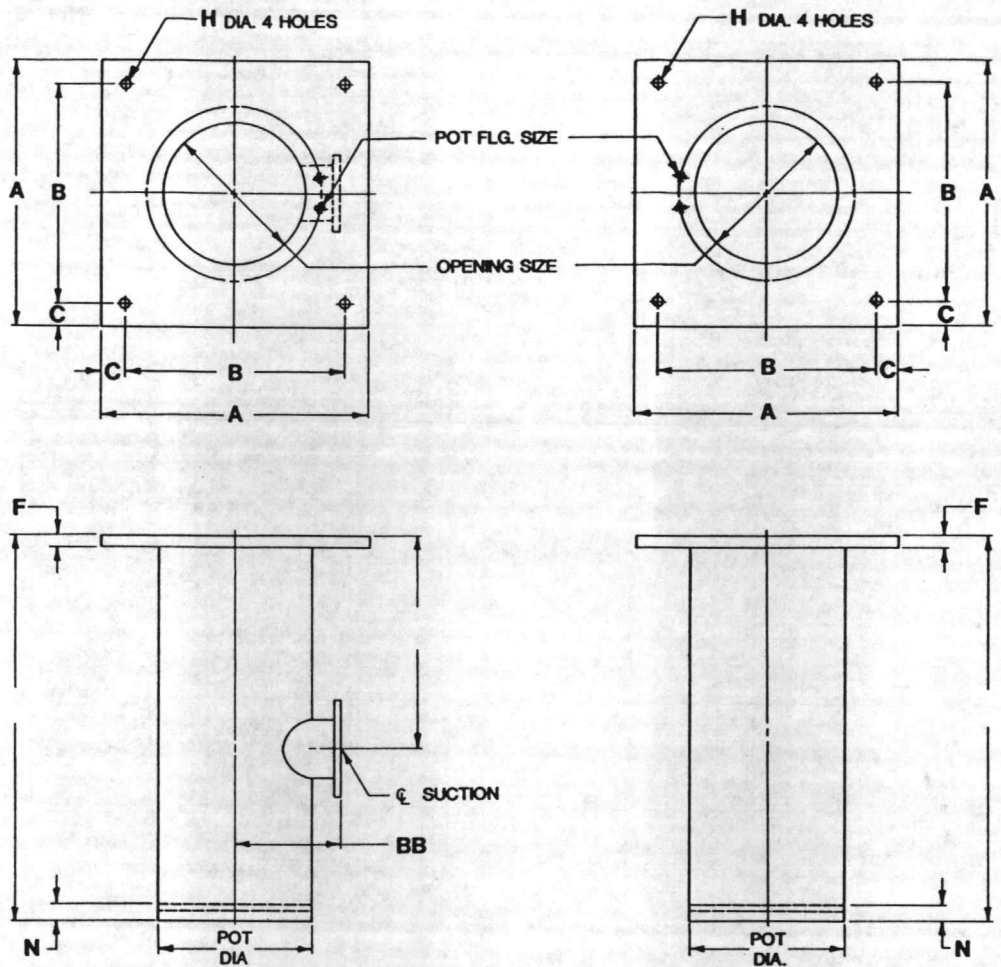

POT SIZE	POT FLG. SIZE	OPNG. SIZE	A	B	BB	C	F	H	N	SUCT. SIZE	POT DIA.
8	10	8 1/16	18	15	7 13/16	1 1/2	1	3/4	1 5/8	6	8 5/8
10	10	10 3/16	18	15	8 7/8	1 1/2	1 1/4	3/4	1 7/8	6	10 3/4
12	14	12 1/16	23	19	9 7/8	2	1 1/4	7/8	1 7/8	8	12 3/4
16	16	15 1/4	27	22	11 1/2	2 1/2	1 1/4	7/8	1 7/8	10	16
18	20	17 1/4	27	22	12 1/2	2 1/2	1 1/2	7/8	2 1/8	10	18
20	20	19 1/4	30	25	13 1/2	2 1/2	1 1/2	1	2 1/8	12	20
24	24	23 1/4	34	28	15 1/2	3	1 1/2	1	2 1/8	14	24
30	30	29 1/4	40	35	18 1/2	2 1/2	1 3/4	1	2 1/8	16	30
36	24	35 1/4	48	42	N/A	3	1 3/4	1 1/8	2 3/8	N/A	36
36	36	26	48	42	21 1/2	3	1 3/4	1 1/8	2 3/8	16	36

NOM. SIZE	FLG. DIA.	FLG. THK.	NO. BOLTS	TAP SIZE	BOLT CIRC.
4	9	1	8	5/8-11	7-1/2
6	11	1	8	3/4-10	9-1/2
8	13-1/2	1-1/8	8	3/4-10	11-3/4
10	16	1-1/4	12	7/8-9	14-1/4
12	19	1-1/4	12	7/8-9	17
14	21	1-3/8	12	1-8	18-3/4
16	23-1/2	1-1/2	16	1-8	21-1/4
20	N/A	N/A	20	1 1/8-7	25
24	N/A	N/A	20	1 1/4-7	29-1/2
30	N/A	N/A	28	1 1/4-7	36
36	N/A	N/A	32	1 1/2-6	42-3/4

PRESSURE RATING FOR POT 150 PSL

EC210695

CUSTOMER		P.O.		Fairbanks Morse Pump Corporation	
JOB NAME				TURBINE POT DIMENSIONS	
PUMP SIZE & MODEL	STAGES	GPM	TDH	RPM	ROT
MOTOR	HP	FRAME	PHASE	HERTZ	VOLTS ENCL
1	2/1/86	EC2-13179	CERTIFIED FOR		CERTIFIED BY
REV.	DATE	ECN NO.	DATE		SIZE DWG. NO. 24LYA2366D

