

ATTACHMENT 2
CONSTRUCTION SPECIFICATIONS

SUMMARY OF SPECIFICATIONS

| <u>Section</u> | <u>Title</u> |
|-----------------------|--|
| 00 01 15 | List of Drawings |
| 01 11 00 | Summary of Work |
| 01 30 00 | Administrative Requirements |
| 01 32 16.00 20 | Construction Progress Documentation |
| 01 33 00 | Submittal Procedures |
| 01 35 29.13 | Health, Safety, and Emergency Response |
| 01 45 02 | Quality Control |
| 01 50 00 | Temporary Facilities and Controls |
| 01 57 19.00 20 | Temporary Environmental Controls |
| 02 41 00 | Site Demolition |
| 02 66 00 | Select Fill for Cover |
| 03 30 00 | Concrete |
| 10 14 01 | Signs |
| 31 00 00 | Earthwork |
| 31 05 22 | Geotextiles |
| 32 31 26 | Fencing and Gates |
| 32 92 19 | Seeding |
| 33 24 13 | Monitoring Wells |
| 35 31 19 | Coastal Protection |

**SECTION 00 01 15
LIST OF DRAWINGS**

PART 1 GENERAL

1.1 SUMMARY

This section lists the drawings for the project pursuant to contract clause “DFARS 252.236-7001, Contract Drawings, Maps, and Specifications.”

1.2 CONTRACT DRAWINGS

Contract Drawings are as follows:

| Drawing No. | Revision No. | Title |
|--------------------|---------------------|---|
| G1 | 0 | Vicinity Map, Location Map, and Sheet Index |
| C1 | 0 | Site Plan – Clearing, Grubbing, Surface Debris Removal, and Well and Probe Extensions |
| C2 | 0 | Soil Cover and Revetment Subgrade Plan |
| C3 | 0 | Soil Cover and Shoreline Revetment Final Grading Plan |
| C4 | 0 | Control Points |
| C5 | 0 | Shoreline and Revetment Cross Sections A, B, and C |
| C6 | 0 | Shoreline and Revetment Cross Sections D, E, and F |
| C7 | 0 | Shoreline and Revetment Cross Sections G, H, I, and J |
| C8 | 0 | Soil Cover Boundary Cross Sections Details A, B, C, and D |
| C9 | 0 | Soil Cover Cross Sections Details A-A’ and B-B’ |
| C10 | 0 | Monitoring Well and Methane Monitoring Probe Extension Details |
| C11 | 0 | Details I |
| C12 | 0 | Details II |

END OF SECTION

00 01 15

LIST OF DRAWINGS

**SECTION 01 11 00
SUMMARY OF WORK**

PART 1 GENERAL

1.1 PROJECT DESCRIPTION

Install a soil cover over potentially radiologically impacted soils. Construct a rip rap revetment along San Francisco Bay.

The area at IR Sites 7 and 18 was used as a disposal site for excess large-scale shipyard debris as part of specific engineered fill operations conducted in that area to expand the shoreline. The Navy had limited controls for disposal of certain types of radioactive materials in place at the time of the shoreline expansion which may have allowed for land disposal of certain types of radioactive materials (such as sandblast grit used in decontamination of ships that participated in atomic weapons testing and radioluminescent dials and gauges). Install a soil cover over IR sites 7 and 18 and a shoreline revetment along the India Basin of San Francisco Bay.

1.2 SITE CONTAMINANTS

The following chemicals were identified in soil at IR Sites 7 and 18 as posing risk to human health: metals, volatile organic compounds (VOC), semivolatile organic compounds (SVOC), pesticides, polychlorinated biphenyls (PCB), and radionuclides. Chemicals identified in the sediment along the shoreline at IR Site 7 include metals, pesticides, PCBs, polycyclic aromatic hydrocarbons, and radionuclides. The primary risk to human health and the environment from these chemicals is through direct contact with the soil or sediment, or through external radiation for radionuclides. Risk to industrial workers is present and requires personal protective equipment (PPE) for workers.

1.3 LOCATION

The work shall be located at Hunters Point Shipyard IR Sites 7 and 18, San Francisco, California, as shown on the Drawings.

1.4 SUBMITTALS

Submit the following:

1.4.1 SD-01, Preconstruction Submittal

- a. List of contact personnel; G
- b. Sampling and Analysis Plan (for confirmation sampling of excavations) G

1.5 CONTRACTOR PERSONNEL REQUIREMENTS

1.5.1 Subcontractors and Personnel

Furnish a list of contact personnel of the Contractor and subcontractors, including addresses and

01 11 00-1

telephone numbers for use in the event of an emergency. As changes occur and additional information becomes available, correct and change the information contained in previous lists.

1.5.2 Contact Personnel List

Submit for approval, at least 15 days in advance of the desired date of entry, an original alphabetical list of personnel who require entry into Government property to perform work on the project. Furnish for each person:

- a. Name
- b. Date and place of birth
- c. Citizenship
- d. Home address

The request for personnel passes shall be accompanied with the following certification:

“I hereby certify that all personnel on this list are either born U.S. citizens or naturalized U.S. citizens with the naturalization number shown.”

1.6 CONTRACTOR ACCESS AND USE OF PREMISES

1.6.1 Base Regulations

Ensure that Contractor personnel employed on the base become familiar with and obey base regulations. Keep within the limits of the work and avenues of ingress and egress. Do not enter restricted areas unless required to do so and until cleared for entry. Permission to interrupt any station roads or utility services shall be requested in writing a minimum of 15 calendar days prior to the desired date of interruption. The Contractor’s equipment shall be conspicuously marked for identification.

1.6.2 Working Hours

Regular working hours shall consist of a period established by the Contracting Officer between 6:00 a.m. and 6:00 p.m., Monday through Saturday, excluding Government holidays.

1.6.3 Work Outside Regular Hours

Work outside regular working hours requires Contracting Officer approval. Provide written request 7 calendar days prior to such work to allow arrangements to be made by the Government for inspecting the work in progress. During periods of darkness, work shall be lighted in a manner approved by the Contracting Officer.

1.6.4 Unauthorized Access

Ensure that the public and other unauthorized personnel do not have access to the area during the construction period.

1.7 UNDERGROUND FACILITIES

The locations of existing underground utilities shown on the Drawings are only approximate. Verify the locations of the utilities shown and any other utilities that may be present. Scan the construction site with electromagnetic or sonic equipment, and mark the surface of the ground where existing underground utilities are discovered. Verify the location and elevation of existing piping, utilities, and other types of underground obstructions not indicated but discovered during scanning. Protect all utilities encountered during construction.

1.8 SCHEDULE

Contractor shall schedule construction activity, in addition to other stated requirements, within the constraints and fulfilling the requirements of Section 31 00 00 Earthwork, and Section 01 57 19.00 20 Temporary Environmental Controls. In all cases, construction shall be completed within 180 days of the start of clearing and grubbing.

1.9 DELAYS

Notify the Contracting Officer of delays or changes in construction schedule within 48 hours. Cessation of construction activities resulting from delays shall not constitute the release of Contractor's responsibility to maintain a tidy, secured, and protected site. In such case, Contractor shall protect all surfaces from erosion and all materials from degradation. When construction activities resume, Contractor shall return grades and installed items to their condition before construction ceased.

1.10 ESTIMATION OF EARTHWORK

Topographical and survey information on Drawings must be field verified. Accurate cut and fill volume must be determined by Contractor after clearing and grubbing and surface debris removal has been performed.

1.11 LIMITS OF RESPONSIBILITY

The designer and its subcontractors shall not be responsible for variances from the construction specifications, design drawings, and other requirements and recommendations unapproved by the designer.

PART 2 PRODUCTS

Not used.

PART 3 EXECUTION

Not used.

END OF SECTION
01 11 00-3

SUMMARY OF WORK

**SECTION 01 30 00
ADMINISTRATIVE REQUIREMENTS**

PART 1 GENERAL

1.1 REFERENCES

The publications listed below form a part of this specification to the extent referenced. The publications are referred to in the text by the basic designation only.

CODE OF FEDERAL REGULATIONS (CFR)

- | | |
|------------|------------------------------|
| 15 CFR 772 | Definition of Terms |
| 15 CFR 773 | Special Licensing Procedures |

1.2 SUBMITTALS

Submit the following in accordance with Section 01 33 00 Submittal Procedures.

1.2.1 SD-01, Preconstruction Submittal

- a. List of Contact Personnel; G
- b. View Location Map; G
- c. Progress and Completion Pictures; G
- d. Personnel List; G
- e. Vehicle List; G
- f. Site Specific Health and Safety Plan; G
- g. Imported Fill Sampling Plan; G
- h. Air Monitoring Plan: G
- i. Construction Stormwater Pollution Prevention Plan; G

1.3 VIEW LOCATION MAP

Submit to the Contracting Officer prior to or with the first submittals, a sketch or drawing indicating the required photographic locations. Update as required if the locations are moved.

1.4 PROGRESS AND COMPLETION PICTURES

01 30 00-1

ADMINISTRATIVE REQUIREMENTS

Photographically document site conditions prior to start of construction operations. Provide monthly, and within one month of the completion of work, showing the sequence and progress of work. Take a minimum of 20 photographs each week throughout the entire project from a minimum of ten views from points located by the Contracting Officer. Submit a view location sketch indicating points of view. Submit with the monthly invoice two sets of digital photographs each set on a separate CD-R, cumulative of all photos to date. Indicate photographs demonstrating environmental procedures. Photographs for each month shall be in a separate monthly directory and each file shall be named to indicate its location on the view location sketch. The view location sketch shall also be provided on the CD as digital file. All file names shall include a date designator. Cross reference submittals in the appropriate daily report. Photographs shall be provided for unrestricted use by the Government.

1.5 MINIMUM INSURANCE REQUIREMENTS

Procure and maintain during the entire period of performance under this contract the following minimum insurance coverage:

- a. Comprehensive general liability: \$500,000 per occurrence
- b. Automobile liability: \$200,000 per person, \$500,000 per occurrence for bodily injury, \$20,000 per occurrence for property damage
- c. Workmen's compensation as required by Federal and State workers' compensation and occupational disease laws.
- d. Employer's liability coverage of \$100,000, except in States where workers compensation may not be written by private carriers,
- e. Others as required by State

1.6 CONTRACTOR PERSONNEL REQUIREMENTS

1.6.1 Subcontractors and Personnel

Furnish a list of contact personnel of the Contractor and subcontractors including addresses and telephone numbers for use in the event of an emergency. As changes occur and additional information becomes available, correct and change the information contained in previous lists.

1.6.2 Identification Badges

Identification badges, if required, will be furnished without charge. Application for and use of badges will be as directed.

1.6.3 Contractor Personnel Requirements

01 30 00-2

ADMINISTRATIVE REQUIREMENTS

Failure to obtain entry approval will not affect the contract price or time of completion.

1.7 SUPERVISION

Have at least one qualified supervisor capable of reading, writing, and conversing fluently in the English language on the job site during working hours. In addition, if a Quality Control (QC) representative is required on the contract, then that individual shall also have fluent English communication skills.

1.8 PRECONSTRUCTION CONFERENCE

After award of the contract but prior to commencement of any work at the site, meet with the Contracting Officer to discuss and develop a mutual understanding relative to the administration of the value engineering and safety program, preparation of the schedule prices, shop drawings, and other submittals, scheduling programming, and prosecution of the work. Major subcontractors who will engage in the work shall also attend.

PART 2 PRODUCTS

Not used.

PART 3 EXECUTION

Not used.

END SECTION

01 30 00-3

ADMINISTRATIVE REQUIREMENTS

SECTION 01 32 16.00 20
CONSTRUCTION PROGRESS DOCUMENTATION

PART 1 GENERAL

1.1 SUBMITTALS

Submit the following in accordance with Section 01 33 00 Submittal Procedures.

1.1.1 SD-01, Preconstruction Submittals

- a. Construction schedule; G
- b. Material delivery schedule; G

1.2 CONSTRUCTION SCHEDULE

Within 21 days after receipt of the Notice of Award, prepare and submit to the Contracting Officer for approval a Critical Path Method (CPM) and Completed Network Schedule, including a completed list of definable features of work, in accordance with the terms in Contract Clause "FAR 52.236-15, Schedules for Construction Contracts," except as modified in this contract.

1.3 MATERIAL DELIVERY SCHEDULE

Within 21 calendar days after approval of the proposed construction schedule, submit for Contracting Officer approval a schedule showing procurement plans for materials and rental equipment. Submit in the format and content as prescribed by the Contracting Officer, and include as a minimum the following information:

- a. Description
- b. Date of the purchase order
- c. Promised shipping date
- d. Name of the manufacturer or supplier
- e. Date delivery is expected
- f. Date the material or equipment is required, according to the current construction schedule.

1.4 NETWORK ANALYSIS SYSTEM (NAS)

The Contractor shall use the CPM to schedule and control construction activities. The schedule shall identify at a minimum:

- Construction time for all major systems and components
- Manpower requirements for each activity
- Major submittals and submittal processing time

1.4.1 CPM Submittals and Procedures

Submit all network analysis and updates in hard copy. The network analysis system shall be kept current, with changes made to reflect the actual progress and status of construction.

1.5 UPDATED SCHEDULES

Update the construction schedule and equipment delivery schedule at monthly intervals or when the schedule has been revised. Reflect any changes that occurred since the last update. Submit copies of the purchase orders and confirmation of the delivery dates as directed.

PART 2 PRODUCTS

Not used.

PART 3 EXECUTION

Not used.

END OF SECTION

**SECTION 01 33 00
SUBMITTAL PROCEDURES**

PART 1 GENERAL

1.1 DEFINITIONS

1.1.1 Submittal

Shop Drawings, product data, samples, and administrative submittals presented for review and approval. Contract Clauses "FAR 52.236-5, Material and Workmanship," paragraph (b) and "FAR 52.236-21, Specifications and Drawings for Construction," paragraphs (d), (e), and (f) apply to all "submittals."

1.1.2 Types of Submittals

All submittals are classified as indicated in Paragraph 1.2, Schedule of Submittal Descriptions. The submittals also are grouped as follows:

- a. Shop Drawings: As used in this section, drawings, schedules, diagrams, and other data prepared specifically for this Contract, by the Contractor, or through the Contractor by way of a subcontractor, manufacturer, supplier, distributor, or other lower-tier contractor, to illustrate a portion of the work.
- b. Product data: Preprinted material such as illustrations, standard schedules, performance charts, instructions, brochures, diagrams, manufacturer's descriptive literature, catalog data, and other data to illustrate a portion of the work, but not prepared exclusively for this Contract.
- c. Samples: Physical examples of products, materials, equipment, assemblies, or workmanship that are physically identical to a portion of the work, illustrate a portion of the work, or establish standards for evaluating the appearance of the finished work or both.
- d. Administrative submittals: Data presented for review and approval to ensure that the administrative requirements of the project are adequately met but not to ensure directly that the work is in accordance with the design concept and in compliance with the Contract documents.

1.2 SCHEDULE OF SUBMITTAL DESCRIPTIONS (SD)

SD-01, Preconstruction Submittals

Certificates of insurance
Surety bonds
List of proposed subcontractors
List of proposed products
Construction Progress Schedule

Submittal schedule
Schedule of values
Health and safety plan
Work plan
Quality control plan
Sampling and analysis plan
Environmental protection plan, including ecological management and mitigation procedures

SD-02, Shop Drawings

Drawings, diagrams, and schedules specifically prepared to illustrate some portion of the work.

Diagrams and instructions from a manufacturer or fabricator for use in producing the product and as aids to the contractor for integrating the product or system into the project.

Drawings prepared by or for the contractor to show how multiple systems and interdisciplinary work will be coordinated.

SD-03, Product Data

Catalog cuts, illustrations, schedules, diagrams, performance charts, instructions, and brochures illustrating size, physical appearance, and other characteristics of materials or equipment for some portion of the work.

Samples of warranty language when the contract requires extended product warranties.

SD-04, Samples

Physical examples of materials, equipment, or workmanship that illustrate functional and aesthetic characteristics of a material or product and establish standards that can be used to judge the work.

Color samples from the manufacturer's standard line (or custom color samples if specified) to be used in selecting or approving colors for the project.

Field samples and mock-ups constructed on the project site to establish standards that can be used to judge the work. Includes assemblies or portions of assemblies that are to be incorporated into the project and those that will be removed at the conclusion of the work.

SD-05, Design Data

Calculations, mix designs, analyses, or other data pertaining to a part of the work.

SD-06, Test Reports

Report signed by authorized official of testing laboratory that a material, product, or system identical to the material, product, or system to be provided has been tested in accord with

specified requirements. (Testing must have occurred within 3 years of the date of contract award for the project.)

Report that includes findings of a test required to be performed by the contractor on an actual portion of the work or prototype prepared for the project before shipment to the job site.

Report that includes finding of a test made at the job site or on a sample taken from the job site, on a portion of work during or after installation.

Investigation reports

Daily checklists

Final acceptance test and operational test procedure

SD-07, Certificates

Statements signed by responsible officials of the manufacturer of the product, system, or material attesting that the product, system, or material meets the specification requirements. Must be dated after award of the project contract and clearly name the project.

Document required of the Contractor, or of a supplier, installer, or subcontractor through the Contractor, the purpose of which is to further the quality of orderly progression of a portion of the work by documenting procedures, acceptability of methods, or personnel qualifications.

SD-08, Manufacturer's Instructions

Preprinted material describing the installation of a product, system, or material, including special notices and Material Safety Data Sheets concerning impedances, hazards, and safety precautions.

SD-09, Manufacturer's Field Reports

Documentation of the testing and verification of actions taken by the manufacturer's representative to confirm compliance with the manufacturer's standards or instructions.

Factory test reports.

SD-10, Operation and Maintenance Data

Data intended to be incorporated in operations and maintenance manuals.

SD-11, Closeout Submittals

Documentation to record compliance with technical or administrative requirements or to establish an administrative mechanism.

As-built Drawings

As-built Field Summary Report
Special warranties
Posted operating instructions
Training plan

1.2.1 Approving Authority

The person authorized to approve a submittal.

1.2.2 Work

As used in this section, on- and off-site construction required by the Contract documents, including labor necessary to produce the construction and materials, products, equipment, and systems incorporated or to be incorporated in such construction.

1.3 SUBMITTALS

Submit the following in accordance with the requirements of this section.

1.3.1 SD-11, Closeout Submittals

- a. Submittal register; G
- b. As-built drawings; G
- c. As-built field summary report; G

1.4 USE OF SUBMITTAL REGISTER OR DATABASE

Prepare and maintain a submittal register as work progresses. Use the electronic submittal register program furnished by the Government or any other format. Do not change data which are output in columns (c), (d), (e), and (f) as delivered by the Government; retain data which are output in columns (a), (g), (h), and (i) as approved.

1.4.1 Submittal Register

Submit a hard copy of the submittal register and also as an electronic database. Submit with the quality control plan and the project schedule required by Section 01 45 02 Quality Control and Section 01 32 16.00 20 Construction Progress Documentation. Do not change data in columns (c), (d), (e), and (f) as delivered by the Government. Verify that all submittals required for the project are listed and add missing submittals. Complete the following on the register:

Column (a) Activity Number: Activity number from the project schedule.

Column (g) Contractor Submit Date: Scheduled date for the approving authority to receive submittals.

Column (h) Contractor Approval Date: Date the Contractor needs approval of the submittal.

Column (i) Contractor Material: Date that the Contractor needs material delivered to Contractor control.

1.4.2 Contractor Use of the Submittal Register

Update the following fields in the submittal register:

Column (b) Transmittal Number: Contractor assigned list of consecutive numbers.

Column (j) Action Code (k): Date of action used to record Contractor's review when forwarding submittals to quality control (QC).

Column (l): List date of submittal transmission.

Column (q): List date approval is received.

1.4.3 Approving Authority Use of the Submittal Register

Update the following fields in the submittal register:

Column (b):

Column (l): List date of submittal receipt.

Column (m) through (p).

Column (q): List date returned to Contractor.

1.4.4 Contractor Action Code and Action Code

Entries used will be as follows:

NR - Not received

AN - Approved as noted

A - Approved

RR - Disapproved, Revise, and Resubmit

1.4.5 Copies Delivered to the Government

Deliver one copy of the submitted register updated by the Contractor to Government with each invoice request. Deliver in electronic format, unless a paper copy is requested by the Contracting Officer.

1.5 PROCEDURES FOR SUBMITTALS

1.5.1 Reviewing, Certifying, Approving Authority

The QC Manager, in accordance with Section 01 45 02 Quality Control, shall be responsible for reviewing and certifying that submittals are in compliance with contract requirements. The approving authority on submittals is the QC Manager unless otherwise specified for the specific submittal. At each "Submittal" paragraph in the individual specification sections, the notation "G" following a submittal item indicates that the Contracting Officer is the approving authority.

1.5.2 Constraints

- a. Submittals listed or specified in this Contract shall conform to the provisions of this section, unless explicitly stated otherwise.
- b. Submittals shall be complete for each definable feature of work; components of the definable feature interrelated as a system shall be submitted at the same time.
- c. When acceptability of a submittal is dependent on conditions, items, or materials included in separate, subsequent submittals, the submittal will be returned without review.
- d. Approval of a separate material, product, or component does not imply approval of the assembly in which the item functions.

1.5.3 Scheduling

- a. Coordinate scheduling, sequencing, preparing, and processing of submittals with performance of the work so that work will not be delayed by submittal processing. Allow for potential requirements to resubmit.
- b. Except as specified otherwise, allow a review period, beginning with receipt by the approving authority, that includes at least 15 working days for submittals for QC Manager approval and 20 working days for submittals for Contracting Officer approval. The period of review for submittals with Contracting Officer approval begins when the Government receives the submittal from the QC Manager. The period of review for each resubmittal is the same as for the initial submittal.

1.5.4 Variations

Variations from contract requirements require Government approval pursuant to Contract Clause "FAR 52.236-21, Specifications and Drawings for Construction," and will be considered where advantageous to the Government.

When proposing a variation, submit a written request to the Contracting Officer, with documentation of the nature and features of the variation and an explanation why the variation is desirable and beneficial to the Government. If lower cost is a benefit, also include an estimate of the cost saving. Identify the proposed variation separately and include documentation for the proposed variation along with the required submittal for the item. When submitting a variation for approval, the Contractor warrants the following:

1.5.4.1 Variation Is Compatible

The Contract has been reviewed to establish that the variation, if incorporated, will be compatible with other elements of the work.

1.5.4.2 Review Schedule Is Modified

In addition to the normal submittal review period, a period of 10 working days will be allowed for consideration by the Government of submittals with variations.

1.5.5 Contractor's Responsibilities

- a. Determine and verify field measurements, materials, field construction criteria; review each submittal; and check and coordinate each submittal with requirements of the work and Contract documents.
- b. Transmit submittals to the QC Manager in orderly sequence; in accordance with the approved submittal register; and to prevent delays in the work, delays to the Government, or delays to separate contractors.
- c. Advise the Contracting Officer of the variation, as required by Paragraph 1.5.4, Variations.
- d. Correct and resubmit submittal as directed by the approving authority. When resubmitting disapproved transmittals or transmittals noted for resubmittal, the Contractor shall provide a copy of the transmittal submitted previously, including all reviewer comments, for use by the approving authority. Direct specific attention, in writing or on resubmitted submittal, to revisions not requested by the approving authority on previous submissions.
- e. Furnish additional copies of submittals when requested by the Contracting Officer, to a limit of 20 copies per submittal.
- f. Complete work that must be accomplished as a basis of a submittal in time to allow the submittal to occur as scheduled.
- g. Ensure no work has begun until submittals for that work have been returned as "approved," or "approved as noted" or "approved except as noted; resubmission not required," except to the extent that a portion of the work must be accomplished as a basis for the submittal.

1.5.6 QC Manager Responsibilities

- a. Note the date the submittal was received from the Contractor on each submittal.
- b. Review each submittal and check and coordinate each submittal with requirements of the work and Contract documents.
- c. Review submittals for conformance with project design concepts and compliance with Contract documents.

- d. Act on submittals, determining the appropriate action based on the QC Manager's review of the submittal.
 - (1) When the QC Manager is the approving authority, take the appropriate action on the submittal from the possible actions defined in Paragraph 1.5.8, Actions Possible.
 - (2) When the Contracting Officer is the approving authority or when a variation has been proposed, forward the submittal to the Government with the certifying statement or return the submittal marked "not reviewed" or "revise and resubmit," as appropriate. The QC Manager's review of the submittal determines the appropriate action.
- e. Ensure that material is clearly legible.
- f. Stamp each sheet of each submittal with the QC certifying statement or approving statement, except that data submitted in bound volume or on one sheet printed on two sides may be stamped on the front of the first sheet only.

- (1) When the approving authority is the Contracting Officer, the QC Manager will certify submittals forwarded to the Contracting Officer with the following certifying statement:

"I hereby certify that the (equipment) (material) (article) shown and marked in this submittal is that proposed to be incorporated with Contract Number [____], is in compliance with the contract Drawings and specification, can be installed in the allocated spaces, and is submitted for Government approval."

Certified by Submittal Reviewer _____ Date _____
(Signature when applicable)

Certified by QC Manager _____ Date _____
(Signature)

- (2) When the approving authority is the QC Manager, the QC Manager will use the following approval statement when returning submittals to the Contractor as "approved" or "approved as noted."

"I hereby certify that the (material) (equipment) (article) shown and marked in this submittal and proposed to be incorporated with Contract Number [____], is in compliance with the contract Drawings and specification, can be installed in the allocated spaces, and is _____ approved for use."

Certified by Submittal Reviewer _____ Date _____
(Signature when applicable)

Approved by QC Manager _____ Date _____
(Signature)

- g. Sign the certifying statement or approval statement. The person signing the certifying statements shall be the QC Manager member designated in the approved QC plan. The signatures shall be original and in ink. Stamped signatures are not acceptable.
- h. Update the submittal register [database] as submittal actions occur and maintain the submittal register at the project site until final acceptance of all work by the Contracting Officer.
- i. Retain a copy of approved submittals at the project site, including the Contractor's copy of approved samples.

1.5.7 Government's Responsibilities

When the approving authority is the Contracting Officer, the Government will:

- a. Note the date the submittal was received from the QC Manager on each submittal for which the Contracting Officer is the approving authority.
- b. Review submittals for approval within the scheduling period specified and only for conformance with project design concepts and compliance with Contract documents.
- c. Identify returned submittals with one of the actions defined in Paragraph 1.5.8, Actions Possible, and with markings appropriate for the action indicated.

1.5.8 Actions Possible

Submittals will be returned with one of the following notations:

- a. Submittals marked "not reviewed" will indicate the submittal has been previously reviewed and approved, is not required as a submittal, does not show evidence of being reviewed and approved by the Contractor, or is not complete. A submittal marked "not reviewed" will be returned with an explanation of the reason it is not reviewed. Returned submittals deemed to lack review by the Contractor or to be incomplete shall be resubmitted with appropriate action, coordination, or change.
- b. Submittals marked "approved" or "approved as submitted" authorize the Contractor to proceed with the work covered.
- c. Submittals marked "approved as noted" or "approved except as noted; resubmission not required" authorize the Contractor to proceed with the work as noted provided the Contractor takes no exception to the notations.
- d. Submittals marked "revise and resubmit" or "disapproved" indicate that the submittal is incomplete or does not comply with the design concept or the requirements of the Contract documents and shall be resubmitted with appropriate changes. No work shall proceed for this item until the resubmittal is approved.

1.6 FORMAT OF SUBMITTALS

1.6.1 Transmittal Form

Transmit each submittal, except sample installations and sample panels, to the office of the approving authority. Transmit submittals with a transmittal form that is prescribed by the Contracting Officer and standard for the project. The transmittal form shall identify the Contractor, indicate the date of the submittal, and include information prescribed by the transmittal form and required in Paragraph 1.6.2, Identifying Submittals. Process transmittal forms to record actions regarding sample panels and sample installations.

1.6.2 Identifying Submittals

Identify submittals, except sample panel and sample installation, with the following information permanently adhered to or noted on each separate component of each submittal and noted on the transmittal form. Mark each copy of each submittal identically, with the following:

- a. Project title and location.
- b. Construction Contract number.
- c. The section number of the specification section by which the submittal is required.
- d. The submittal description (SD) number of each component of the submittal.
- e. When a resubmission, an alphabetic suffix on the submittal description, for example, SD-10A, to indicate the resubmission.
- f. The name, address, and telephone number of the subcontractor, supplier, manufacturer, and any other second-tier contractor associated with the submittal.
- g. Product identification and location in project.

1.6.3 Format for Product Data

- a. Present product data submittals for each section as a complete, bound volume. Include a table of contents listing page and catalog item numbers for product data.
- b. Indicate, by prominent notation, each product that is being submitted; indicate the specification section number and paragraph number to which it pertains.
- c. Supplement product data with material prepared for the project to satisfy submittal requirements for which product data do not exist. Identify this material as developed specifically for the project.

1.6.4 Format for Shop Drawings

- a. Shop Drawings shall not be less than A4, 8½ by 11 inches, nor more than AO, 30 by 42 inches.
- b. Present shop Drawings as a part of the bound volume for the submittals required by the section. Present larger Drawings in sets.

- c. Include on each Drawing the Drawing title, number, date, and revision numbers and dates, in addition to the information required in Paragraph 1.6.2, Identifying Submittals.
- d. Dimension Drawings, except diagrams and schematic Drawings; prepare Drawings demonstrating interface with other trades to scale. Dimensions of shop Drawings shall be the same unit of measure as indicated on the contract Drawings. Identify materials and products for work shown.

1.6.5 Format of Samples

- a. Furnish samples in the sizes below, unless otherwise specified or unless the manufacturer has prepackaged samples of approximately the same size as specified:
 - (1) Color Selection Samples: 2 inches by 4 inches.

1.6.6 Format of Administrative Submittals

- a. When the submittal includes a document that is to be used in the project or will become a part of the project record, other than as a submittal, do not apply the Contractor's approval stamp to the document, but to a separate sheet accompanying the document.

1.7 QUANTITY OF SUBMITTALS

1.7.1 Number of Copies of Product Data

- a. Submit six copies of submittals of product data requiring review and approval only by the QC Manager and seven copies of product data requiring review and approval by the Contracting Officer.

1.7.2 Number of Copies of Shop Drawings

Submit shop Drawings in compliance with the quantity requirements specified for product data.

1.7.3 Number of Samples

- a. Submit two samples, or two sets of samples showing range of variation, of each required item. One approved sample or set of samples will be retained by the approving authority, and one will be returned to the Contractor.

1.7.4 Number of Copies of Administrative Submittals

- a. Unless otherwise specified, submit the administrative submittals in compliance with the quantity requirements specified for product data.

PART 2 PRODUCTS

Not used.

PART 3 EXECUTION

Not used.

SUBMITTAL REGISTER (PART A)

CONTRACT NO: N62473-04-D-3213 PROJECT TITLE HPS IR Sites 7 and 18

| SPEC SECTION NO. (a) | SD NO & TYPE OF SUBMITTAL-MATL OR PRODUCT (b) | SPEC PARA NO. (c) | CLASSIF/ APPR BY CO (d) | GOVT OR A/E REVR (e) | TRANS CONTL NO. (f) | PLANNED SUBMITTAL DATE (g) |
|-------------------------|--|----------------------|---|-------------------------|------------------------|-------------------------------|
| 01 11 00 | SD-01, PRECONSTRUCTION SUBMITTAL a. List of Contact Personnel b. Sampling and Analysis Plan | 1.4 | G G | | | |
| 01 30 00 | SD-01, PRECONSTRUCTION SUBMITTAL a. List of Contact Personnel b. View Location Map c. Progress and Completion Pictures d. Personnel List e. Vehicle List f. Site Specific Health and Safety Plan g. Imported Fill Sampling Plan h. Air Monitoring Plan i. Construction Stormwater Pollution Prevention Plan | 1.2.1 | G G G G G G G G G | | | |
| 01 32 16.00 20 | SD-01, PRECONSTRUCTION SUBMITTALS a. Construction Schedule b. Material Delivery Schedule | 1.1.1 | G G | | | |
| 01 33 00 | SD-11, CLOSEOUT SUBMITTALS a. Submittal Register b. As-built Drawings c. As-built Field Summary Report | 1.3.1 | G G G | | | |
| 01 35 29.13 | SD-02, SHOP DRAWINGS a. Work Zones b. Decontamination Facilities | 1.3.1 | G G | | | |
| 01 35 29.13 | SD-03, PRODUCT DATA a. Site Control Log b. Employee Certificates | 1.3.2 | | | | |
| 01 35 29.13 | SD-06, FIELD TEST REPORTS a. Dosimetry Results b. Air Sampling Results | 1.3.3 | | | | |
| 01 45 02 | SD-01, PRECONSTRUCTION SUBMITTAL a. Quality Control (QC) Plan | 1.2.1 | G | | | |
| 01 50 00 | SD-02, DRAWINGS a. Traffic Control Plan b. Project Sign | 1.2.1 | G | | | |

IR SITES 7 AND 18
COVER AND REVETMENT
HUNTERS POINT SHIPYARD

05-29-2009

| SPEC SECTION NO. (a) | SD NO & TYPE OF SUBMITTAL-MATL OR PRODUCT (b) | SPEC PARA NO. (c) | CLASSIF/ APPR BY CO (d) | GOVT OR A/E REVR (e) | TRANS CONTL NO. (f) | PLANNED SUBMITTAL DATE (g) |
|----------------------|---|-------------------|-------------------------|----------------------|---------------------|----------------------------|
| 01 57 19.00 20 | SD-01, PRECONSTRUCTION SUBMITTALS a. Environmental Protection Plan b. Preconstruction Survey Report c. Site Health and Safety Plan | 1.4.1 | G G | | | |
| 01 57 19.00 20 | SD-07, CERTIFICATES a. Solid Waste Disposal Permit/Manifests b. Disposal Permit/Manifests for Hazardous Waste c. Erosion and Sediment Control Inspection Reports | 1.4.2 | G G G | | | |
| 02 41 00 | SD-01, PRECONSTRUCTION SUBMITTAL a. Demolition Plan | 1.2.1 | G | | | |
| 02 61 13 | SD-02, SHOP DRAWINGS a. Surveys | 1.3.1 | G | | | |
| 02 61 13 | SD-03, PRODUCT DATA a. Work Plan b. Closure Report | 1.3.2 | G G | | | |
| 02 61 13 | SD-06, TEST REPORTS a. Backfill b. Surveys c. Confirmation Sampling and Analysis d. Sampling Liquid e. Compaction | 1.3.3 | G G G G G | | | |
| 02 66 00 | SD-03, PRODUCT DATA a. Materials Handling Plan | 1.3.1 | | | | |
| 02 66 00 | SD-04, SAMPLES a. Select Fill | 1.3.2 | | | | |
| 02 66 00 | SD-06, TEST REPORTS a. Borrow Source Assessment b. Select Fill and Topsoil Material Tests c. Moisture Content and Density Tests of In-Place Select Fill | 1.3.3 | G | | | |
| 03 30 00 | SD-02, SHOP DRAWINGS a. Welded Wire Fabric | 1.2.1 | G | | | |
| 03 30 00 | SD-05, DESIGN DATA a. Concrete Mix Design | 1.2.2 | G | | | |
| 03 30 00 | SD-07, CERTIFICATES a. Cement b. Aggregate c. Admixtures | 1.2.3 | | | | |

01 33 00-14

CHAD-3213-0019-0022

SUBMITTAL PROCEDURES

IR SITES 7 AND 18
COVER AND REVETMENT
HUNTERS POINT SHIPYARD

05-29-2009

| SPEC SECTION NO. (a) | SD NO & TYPE OF SUBMITTAL-MATL OR PRODUCT (b) | SPEC PARA NO. (c) | CLASSIF/ APPR BY CO (d) | GOVT OR A/E REVR (e) | TRANS CONTL NO. (f) | PLANNED SUBMITTAL DATE (g) |
|----------------------|--|-------------------|-------------------------|----------------------|---------------------|----------------------------|
| | d. Welded Wire Fabric | | | | | |
| 10 14 01 | SD-02, DRAWINGS a. Warning Sign | 1.2.1 | G | | | |
| 31 00 00 | SD-01, PRECONSTRUCTION SUBMITTALS a. Sampling and Analysis Plan | 1.3.1 | G | | | |
| 31 00 00 | SD-03, PRODUCT DATA a. Composite Turf Reinforcement Matting | 1.3.2 | | | | |
| 31 00 00 | SD-06, FIELD TEST REPORTS a. Soil Material Tests b. Confirmation Screening Sampling Results | 1.3.3 | G | | | |
| 31 00 00 | SD-07, CERTIFICATES a. California Registered Civil Engineer or Geologist Certification | 1.3.4 | | | | |
| 31 00 00 | SD-11, CLOSEOUT SUBMITTALS a. Final Soil Cover Survey With As-Built Drawings b. Survey Information on Permanent Local Site Monuments | 1.3.5 | | | | |
| 31 05 22 | SD-03, PRODUCT DATA a. Thread b. Manufacturing Quality Control Sampling and Testing | 1.3.1 | | | | |
| 31 05 22 | SD-04, SAMPLES a. Geotextile | 1.3.2 | | | | |
| 31 05 22 | SD-07, CERTIFICATES a. Geotextile | 1.3.3 | | | | |
| 32 31 26 | SD-03, MANUFACTURER'S CATALOG DATA a. Fencing Components b. Accessories | 1.4.1 | | | | |
| 32 92 19 | SD-01, PRECONSTRUCTION SUBMITTAL a. Vegetation Establishment Plan | 1.3.1 | | | | |
| 32 92 19 | SD-03, PRODUCT DATA a. Seed Mixes b. Mulches c. Binders/Tackifiers d. Fertilizer e. Straw | 1.3.2 | | | | |
| 32 92 19 | SD-06, TEST REPORTS | 1.3.3 | | | | |

01 33 00-15

CHAD-3213-0019-0022

SUBMITTAL PROCEDURES

IR SITES 7 AND 18
COVER AND REVETMENT
HUNTERS POINT SHIPYARD

05-29-2009

| SPEC SECTION NO. (a) | SD NO & TYPE OF SUBMITTAL-MATL OR PRODUCT (b) | SPEC PARA NO. (c) | CLASSIF/ APPR BY CO (d) | GOVT OR A/E REVR (e) | TRANS CONTL NO. (f) | PLANNED SUBMITTAL DATE (g) |
|----------------------|---|-------------------|-------------------------|----------------------|---------------------|----------------------------|
| | a. Soil Compaction Tests | | | | | |
| 32 92 19 | SD-07, CERTIFICATES a. State Certification and Approval for Seed | 1.3.4 | | | | |
| 33 24 13 | SD-03, PRODUCT DATA a. Casing b. Cement c. Protective Cover | 1.2.1 | | | | |
| 33 24 13 | SD-11, CLOSEOUT SUBMITTAL a. Horizontal Location (Northing and Easting) b. Top of Casing (TOC) Elevation c. Adjacent Ground Elevation | 1.2.2 | | | | |
| 35 31 19 | SD-03, PRODUCT DATA a. Riprap b. Filter Material c. Gaging Table Data d. Filter Rock e. Bulk Specific Gravity of Stone and Redesign | 1.4.1 | G G G | | | |
| 35 31 19 | SD-04, SAMPLES a. Stone | 1.4.2 | G | | | |
| 35 31 19 | SD-07, CERTIFICATES a. Rip Rap Specific Gravity b. Filter Fabric c. Filter Rock d. Laboratory e. Weight Scale Certification f. Certified Weight Scale Tickets | 1.4.3 | G | | | |

END OF SECTION

SECTION 01 35 29.13
HEALTH, SAFETY, AND EMERGENCY RESPONSE

PART 1 GENERAL

1.1 REFERENCES

The publications listed below form a part of this specification to the extent referenced. The publications are referred to in the text by the basic designation only.

NATIONAL INSTITUTE FOR OCCUPATIONAL SAFETY AND HEALTH (NIOSH)

NIOSH 85-115 (1985) Occupational Safety and Health Guidance Manual for Hazardous Waste Site Activities

U.S. ARMY CORPS OF ENGINEERS (USACE)

EM 385-1-1 (2008) Safety and Health Requirements Manual

CODE OF FEDERAL REGULATIONS (CFR)

10 CFR 20 Standards for Protection Against Radiation

29 CFR 1904 Recording and Reporting Occupational Injuries and Illnesses

29 CFR 1910 Occupational Safety and Health Standards

29 CFR 1910.120 Hazardous Waste Operations and Emergency Response

29 CFR 1926 Safety and Health Regulations for Construction

29 CFR 1926.65 Hazardous Waste Operations and Emergency Response

49 CFR 171 General Information, Regulations, and Definitions

49 CFR 172 Hazardous Materials Table, Special Provisions, Hazardous Materials Communications, Emergency Response Information, and Training Requirements

1.2 DESCRIPTION OF WORK

This section requires Contractors to implement practices and procedures for working safely and in compliance with OSHA and USACE regulation while performing cleanup activities on uncontrolled hazardous waste sites.

1.3 SUBMITTALS

Submit the following in accordance with Section 01 33 00 Submittal Procedures.

1.3.1 SD-02, Shop Drawings

- a. Work Zones; G
- b. Decontamination Facilities; G

1.3.2 SD-03, Product Data

- a. Site Control Log;
- b. Employee Certificates;

1.3.3 SD-06, Field Test Reports

- a. Dosimetry Results
- b. Air Sampling Results

1.4 REGULATORY REQUIREMENTS

Comply with EM 385-1-1, OSHA requirements in 29 CFR 1910 and 29 CFR 1926 with work performed under this contract, especially OSHA's Standards 29 CFR 1926.65 and 29 CFR 1910.120 and state specific OSHA requirements where applicable. Submit to the Contracting Officer for resolution matters of interpretation of standards before starting work. The most stringent requirements apply where the requirements of this specification, applicable laws, criteria, ordinances, regulations, and referenced documents vary.

1.5 PRECONSTRUCTION SAFETY CONFERENCE

Conduct a preconstruction safety conference prior to the start of site activities and after submission of the Contractor's APP/SSHP. The objective of the meeting will be to discuss health and safety concerns related to the impending work, discuss project health and safety organization and expectations, review and answer comments and concerns regarding the APP/SSHP or other health and safety concerns the Contractor may have.

Ensure that those individuals responsible for health and safety at the project level are available and attend this meeting.

1.6 ACCIDENT PREVENTION PLAN/SITE SAFETY AND HEALTH PLAN
(APP/SSHP)

Develop and implement a Site Safety and Health Plan and attach to the Accident Prevention Plan (APP) as an appendix (APP/SSHP). Address all occupational safety and health hazards (traditional construction as well as contaminant-related hazards) associated with cleanup operations within the APP/SSHP. Cover each SSHP element in section 28.A.01 of EM 385-1-1 and each APP element in Appendix A of EM 385-1-1. There are overlapping elements in Section 28.A.01 and Appendix A of EM 385-1-1. SSHP appendix elements that overlap with APP elements need not be duplicated in the APP/SSHP provided each SOH issue receives adequate attention and is documented in the APP/SSHP. The APP/SSHP is a dynamic document, subject to change as project operations/execution change. The APP/SSHP will require modification to address changing and previously unidentified health and safety conditions. It is the Contractor's responsibility to ensure that the APP/SSHP is updated accordingly. Submit amendments to the APP/SSHP to the COR as the APP/SSHP is updated. For long duration projects resubmit the APP/SSHP to the COR annually for review. The APP/SSHP must contain all updates.

1.6.1 Acceptance and Modifications

Prior to submittal, the APP/SSHP must be signed and dated by the Safety and Health Manager and the Site Superintendent. Submit for review 14 days prior to the Preconstruction Safety Conference. Deficiencies in the APP/SSHP will be discussed at the preconstruction safety conference, and be revised to correct the deficiencies and resubmitted for acceptance. On site work must not begin until the plan has been accepted. Maintain a copy of the written APP/SSHP on site. Changes and modifications to must be made with the knowledge and concurrence of the Safety and Health Manager, the Site Superintendent, and the Contracting Officer. Bring to the attention of the Safety and Health Manager, the Site Superintendent, and the Contracting Officer any unforeseen hazard that becomes evident during the performance of the work, through the Site Safety and Health Officer (SSHO) for resolution as soon as possible. In the interim, take necessary action to re-establish and maintain safe working conditions in order to safeguard on site personnel, visitors, the public, and the environment. Disregard for the provisions of this specification or the accepted APP/SSHP will be cause for stopping work until the matter has been rectified. 1.6.2 Availability Make available the APP/SSHP in accordance with 29 CFR 1910.120, (b)(1)(v) and 29 CFR 1926.65, (b)(1)(v).

1.7 SITE DESCRIPTION AND CONTAMINATION CHARACTERIZATION

1.7.1 Project/Site Conditions

Refer to the following reports and information for the site description and contamination characterization.

ChaduxTt. 2007. "Final Parcel B Technical Memorandum in Support of a Record of Decision Amendment, Hunters Point Shipyard, San Francisco, California." December 12.

ChaduxTt. 2009. "Final Amended Parcel B Record of Decision, Hunters Point Shipyard, San Francisco, California." January 26.

PRC, Harding Lawson Associates, Levine-Fricke, and Uribe & Associates. 1996. "Parcel B Remedial Investigation, Draft Final Report, Hunters Point Shipyard, San Francisco, California." June 3.

1.8 TASK SPECIFIC HAZARDS, INITIAL PPE, HAZWOPER MEDICAL SURVEILLANCE AND TRAINING APPLICABILITY

Task specific occupational hazards, task specific HAZWOPER medical surveillance and training applicability and task specific initial PPE requirements for the project are listed on the **Task Hazard and Control Sheets** at the end of this section. It is the Contractor's responsibility to reevaluate occupational safety and health hazards as the work progresses and to adjust the PPE and on site operations, if necessary, so that the work is performed safely and in compliance with occupational safety and health regulations.

1.9 STAFF ORGANIZATION, QUALIFICATION AND RESPONSIBILITIES

1.9.1 Safety and Health Manager

Safety and Health Manager must be an Industrial Hygienist certified by the American Board of Industrial Hygiene with significant experience with health physics or certified by the American Board of Health Physicists.

1). The Safety and Health Manager must have the following additional qualifications:

a. A minimum of 3 years experience in developing and implementing safety and health programs at hazardous waste sites.

b. Documented experience in supervising professional and technician level personnel.

c. Documented experience in developing worker exposure assessment programs and air monitoring programs and techniques.

d. Documented experience in managing personal protective equipment programs and conducting PPE hazard evaluations for the types of activities and hazards likely to be encountered on the project.

- e. Working knowledge of state and Federal occupational safety and health regulations.
- 2). The Safety and Health Manager will:
 - a. Be responsible for the development, implementation, oversight, and enforcement of the APP/SSHP.
 - b. Sign and date the APP/SSHP prior to submittal.
 - c. Conduct initial site-specific training.
 - d. Be present on site during the first 3 days of remedial activities and at the startup of each new major phase of work.
 - e. Visit the site as needed and at least once per week for the duration of activities, to audit the effectiveness of the APP/SSHP.
 - f. Be available for emergencies.
 - g. Provide on site consultation as needed to ensure the APP/SSHP is fully implemented.
 - h. Coordinate any modifications to the APP/SSHP with the Site Superintendent, the SSHO, and the Contracting Officer.
 - i. Provide continued support for upgrading/downgrading of the level of personal protection.
 - j. Be responsible for evaluating air monitoring data and recommending changes to engineering controls, work practices, and PPE.
 - k. Review accident reports and results of daily inspections.
 - l. Serve as a member of the Contractor's quality control staff.

1.9.2 Additional Certified Health and Safety Support Personnel

Retain health physics support from a health physicist certified by the American Board of Health Physics to develop radiation protection requirements of the APP/SSHP and, when necessary, visit the site to help implement ionizing radiation protection requirements of the APP/SSHP.

1.9.3 Site Safety and Health Officer

Designate an individual and one alternate as the Site Safety and Health Officer (SSHO). Include the name, qualifications, and work experience of the Site Safety and Health Officer and alternate in the APP/SSHP.

- 1). The SSHO must have the following qualifications:

01 35 29.13-5

- a. A minimum of 2 years experience in implementing safety and health programs at hazardous waste sites where Level C personal protective equipment was required.
 - b. Documented experience in construction techniques and construction safety procedures.
 - c. Working knowledge of Federal and state occupational safety and health regulations.
 - d. Specific training in personal and respiratory protective equipment, confined space entry and in the proper use of air monitoring instruments and air sampling methods including monitoring for ionizing radiation.
- 2). The Site Safety and Health Officer must:
- a. Assist and represent the Safety and Health Manager in on site training and the day to day on site implementation and enforcement of the accepted APP/SSHP.
 - b. Be assigned to the site on a full time basis for the duration of field activities. The SSHO can have collateral duties in addition to Safety and Health related duties. If operations are performed during more than 1 work shift per day, a site Safety and Health Officer must be present for each shift and when applicable, act as the radiation safety officer (RSO) as defined in paragraph 06.E.02 of EM 385-1-1 on radioactive waste cleanup projects.
 - c. Have authority to ensure site compliance with specified safety and health requirements, Federal, state and OSHA regulations and all aspects of the APP/SSHP including, but not limited to, activity hazard analyses, air monitoring, monitoring for ionizing radiation, use of PPE, decontamination, site control, standard operating procedures used to minimize hazards, safe use of engineering controls, the emergency response plan, confined space entry procedures, spill containment program, and preparation of records by performing a daily safety and health inspection and documenting results on the Daily Safety Inspection Log in accordance with 29 CFR 1904.
 - d. Have authority to stop work if unacceptable health or safety conditions exist, and take necessary action to re-establish and maintain safe working conditions.
 - e. Consult with and coordinate any modifications to the APP/SSHP with the Safety and Health Manager, the Site Superintendent, and the Contracting Officer.
 - f. Serve as a member of the Contractor's quality control staff on matters relating to safety and health.
 - g. Conduct accident investigations and prepare accident reports.
 - h. Conduct daily safety inspection and document safety and health findings into the Daily Safety Inspection Log. Track noted safety and health deficiencies to ensure that they are corrected.
 - i. In coordination with site management and the Safety and Health Manager, recommend corrective actions for identified deficiencies and oversee the corrective actions.

1.9.4 Occupational Physician

Utilize the services of a licensed physician, who is certified in occupational medicine by the American Board of Preventative Medicine, or who, by necessary training and experience is Board eligible. The physician must be familiar with this site's hazards and the scope of this project. Include the medical consultant's name, qualifications, and knowledge of the site's conditions and proposed activities in the APP/SSHP. The physician will be responsible for the determination of medical surveillance protocols and for review of examination/test results performed in compliance with 29 CFR 1910.120, (f) and 29 CFR 1926.65, (f) and paragraph MEDICAL SURVEILLANCE.

1.9.5 Persons Certified in First Aid and CPR

At least two persons who are currently certified in first aid and CPR by the American Red Cross or other approved agency must be on site at all times during site operations. They must be trained in universal precautions and the use of PPE as described in the Bloodborne Pathogens Standard of 29 CFR 1910, Section 1030. These persons may perform other duties but will be immediately available to render first aid when needed.

1.9.6 Safety and Health Technicians

For each work crew in the exclusion zone, one person, designated as a Safety and Health technician, must perform activities such as air monitoring, decontamination, and safety oversight on behalf of the SSHO. They must have appropriate training equivalent to the SSHO in each specific area for which they have responsibility and report to and be under the supervision of the SSHO.

1.10 TRAINING

Meet the following requirements in the Contractor's training program for workers performing cleanup operations and who will be exposed to contaminants.

1.10.1 General Hazardous Waste Operations Training

All Personnel performing duties with potential for exposure to on site contaminants must meet and maintain the following 29 CFR 1910.120/29 CFR 1926.65 (e) training requirements:

- a. 40 hours of off site hazardous waste instruction.
- b. 3 days actual field experience under the direct supervision of a trained, experienced supervisor.
- c. 8 hours refresher training annually.

On site supervisors must have an additional 8 hours management and supervisor training specified in 29 CFR 1910.120/29 CFR 1926.65 (e) (4).

d. Specific site training based on the hazards present including radiological.

1.10.2 Pre-entry Briefing

Prior to commencement of on site field activities, all site employees, including those assigned only to the Support Zone, must attend a site-specific safety and health training session. This session will be conducted by the Safety and Health Manager and the Site Safety and Health Officer to ensure that all personnel are familiar with requirements and responsibilities for maintaining a safe and healthful work environment. Thoroughly discuss procedures and contents of the accepted APP/SSHP and Sections 01.B.02 and 28.D.03 of EM 385-1-1 . Each employee must sign a training log to acknowledge attendance and understanding of the training. Notify the Contracting Officer at least 5 days prior to the initial site-specific training session so government personnel involved in the project may attend.

1.10.3 Periodic Sessions

Conduct periodic on site training by the SSHO at least daily for personnel assigned to work at the site during the following day. Address safety and health procedures, work practices, any changes in the APP/SSHP, activity hazard analyses, work tasks, or schedule; results of previous week's air monitoring, review of safety discrepancies and accidents. Convene a meeting prior to implementation of the change must be convened should an operational change affecting on site field work be made, to explain safety and health procedures. Conduct a site-specific training sessions for new personnel, visitors, and suppliers by the SSHO using the training curriculum outlines developed by the Safety and Health Manager. Each employee must sign a training log to acknowledge attendance and understanding of the training.

1.10.4 Other Training

Site specific training for sites where radioactive wastes are to be cleaned up include:

- a. Site specific procedures for handling and storing radioactive materials;
- b. Health and safety hazards associated with exposure to the radioactive material that will be cleaned up or otherwise handled and the purpose and function of protective devices and precautions used to minimize exposures;
- c. Elements of the APP/SSHP and company specific procedures intended to provide protection from radiation exposure;
- d. Worker responsibility to report any unsafe acts which might result in exposure to ionizing radiation;
- e. Appropriate worker response procedures to events that may result in worker exposure to ionizing radiation;
- f. Worker rights and responsibilities with respect to ionizing radiation exposure. Provide training as specified by 29 CFR 1910 Section 146, by the Safety and Health Manager shall for employees who are required to supervise, standby, or enter permit-required confined spaces. Train in

01 35 29.13-8

accordance with 49 CFR 172 Subpart H, Persons involved in any aspect of the transportation of hazardous materials.

1.11 PERSONAL PROTECTIVE EQUIPMENT

1.11.1 Site Specific PPE Program

Provide on site personnel exposed to contaminants with appropriate personal protective equipment. Components of levels of protection (B, C, D and modifications) must be relevant to site-specific conditions, including heat and cold stress potential and safety hazards. Use only respirators approved by NIOSH. Commercially available PPE, used to protect against chemical agent, must be approved by the director of Army Safety through the Chemical Agent Safety and Health Policy Action Committee (CASHPAC). Keep protective equipment and clothing clean and well maintained. Include site-specific procedures to determine PPE program effectiveness and for on site fit-testing of respirators, cleaning, maintenance, inspection, and storage of PPE within the PPE section of the APP/SSHP.

1.11.2 Levels of Protection

The Safety and Health Manager must establish and evaluate as the work progresses the levels of protection for each work activity. Also establish action levels for upgrade or downgrade in levels of PPE. Describe in the SSHP the protocols and the communication network for changing the level of protection. Address air monitoring results, potential for exposure, changes in site conditions, work phases, job tasks, weather, temperature extremes, individual medical considerations, etc. within the PPE evaluation protocol.

1.11.2.1 Initial PPE Components

The following items constitute initial minimum protective clothing and equipment ensembles.

a. Level D. Coveralls or appropriate work clothing, safety/steel toed boots, other PPE as needed (gloves etc).

b. Modified Level D. Includes provisions for Level D but including hard hat, safety glasses, and hearing protection as necessary.

c. Level C.

Full-face air purifying respirator (APR) with NIOSH-approved combination high efficiency particulate air (HEPA)/organic vapor cartridges

Work clothing as prescribed by weather

Steel-toed boots

Chemical resistant boot covers and/or outer boots (PVC/Latex/Neoprene)

Tyvek® coveralls with hoods (as determined by the CHP), elastic wrists and ankles (or equivalent cloth/synthetic fiber)

Nitrile, latex, or vinyl gloves (inner) or cloth liners

Nitrile gloves or PVC (outer) or leather palm gloves

Hearing protection (if necessary)

Cooling vest (if necessary)

Hard-hat
Splash shield (if necessary)
Openings at ankles, wrists, and hoods shall be taped (as directed by the CHP).

d. Level B. •

Supplied air respirator
Work clothing (light or insulated) as prescribed by weather
Steel-toed boots
Chemical resistant boot covers and/or outer boots (as selected by a CIH)
Tyvek® coveralls with hoods (as determined by the CHP), elastic wrists and ankles (or equivalent cloth/synthetic fiber)
Saranex® coveralls with hoods, elastic wrists, and ankles (as determined by a CIH)
Acid gear, splash suit, rain gear, etc. (as determined by a CIH)
Nitrile, latex, or vinyl gloves (inner) and/or cloth liners
Outer gloves (as selected by a CIH)
Hearing protection (if necessary)
Cooling vest (if necessary)
Hard-hat
Splash shield (if necessary)
Openings at ankles, wrists, and hoods shall be taped (as directed by the CHP).

Level D and Modified Level D PPE is anticipated for this project.

1.11.3 PPE for Government Personnel

Three clean sets of personal protective equipment and personal dosimeters for work on radioactive waste cleanup sites and clothing (excluding air-purifying negative-pressure respirators and safety shoes, which will be provided by individual visitors), as required for entry into the Exclusion Zone and/or Contamination Reduction Zone, must be available for use by the Contracting Officer or official visitors. The items must be cleaned and maintained by the Contractor and stored in the clean room of the decontamination facility.

1.12 MEDICAL SURVEILLANCE PROGRAM

Meet 29 CFR 1910.120/29 CFR 1926.65 (f) and the following requirements for medical surveillance program for workers performing cleanup operations and who will be exposed to contaminants. Assure the Occupational Physician or the physician's designee performs the physical examinations and reviews examination results. Participation in the medical surveillance program will be without cost to the employee, without loss of pay and at a reasonable time and place.

1.12.1 Frequency of Examinations

Medical surveillance program participants must receive medical examinations and consultations on the following schedule:

a. Every 12 months

- b. If and when the participant develops signs and symptoms indicating a possible overexposure due to an uncontrolled release of a hazardous substance on the project.
- c. Upon termination or reassignment to a job where medical surveillance program participation is not required, unless his/her previous annual examination/consultation was less than 6 months prior to reassignment or termination.
- d. On a schedule specified by the occupational physician.

1.12.2 Content of Physical Examinations/Consultation

Verify the following information about medical surveillance program participants:

- a. Baseline health conditions and exposure history.
 - b. Allergies/sensitivity/susceptibility to hazardous substances exposure.
 - c. Ability to wear personal protective equipment inclusive of NIOSH certified respirators under extreme temperature conditions.
 - d. Fitness to perform assigned duties.
- Provide the occupational physician with the following information for each medical surveillance program participant:

- a. Information on the employee's anticipated or measured exposure.
- b. A description of any PPE used or to be used.
- c. A description of the employee's duties as they relate to the employee's exposures (including physical demands on the employee and heat/cold stress).
- d. A copy of 29 CFR 1910.120, or 29 CFR 1926.65.
- e. Information from previous examinations not readily available to the examining physician.
- f. A copy of Section 5.0 of NIOSH 85-115.
- g. Information required by 29 CFR 1910 Section 134.

1.12.3 Physician's Written Opinion

Obtain and furnish to the Safety and Health Manager; and the employee before work begins, a copy of the physician's written opinion for each employee. Address the employee's ability to perform hazardous waste site remediation work and containing the following:

- a. The physician's verification of the employee's fitness to perform duties as well as recommended limitations upon the employee's assigned work and/or PPE usage.

- b. The physician's opinion about increased risk to the employee's health resulting from work; and
- c. A statement that the employee has been informed and advised about the results of the examination.

1.12.4 Employee Certificates

Provided on employee certificates, documentation that employees have received medical examinations.

1.12.5 Site Specific Medical Surveillance

Site specific Medical Surveillance medical monitoring will be based on the direction of the Contracting Officer in accordance with current regulations and standards. Additional input will be provided.

1.13 EXPOSURE MONITORING/AIR SAMPLING PROGRAM

Prepare and implement by the Safety and Health Manager an exposure monitoring/air sampling program to identify and quantify safety and health hazards and airborne levels of hazardous substances in order to assure proper selection of engineering controls, work practices and personal protective equipment for affected site personnel. Include action levels for upgrading/downgrading PPE in the program.

1.13.1 Air Sampling and Dosimetry

Use dosimeters to evaluate occupational exposure to radioactive isotopes and ionizing radiation fields in coordination with current standards and procedures at the facility.

1.13.1.1 Evaluation

Radiation dosimetry must be evaluated by an individual or company holding current personnel dosimetry accreditation from the National Voluntary Laboratory Accreditation Program (NVLAP). Electronic dosimetry may be used to assign external dose if approved by the Contracting Officer. Internal intake assessment and applicable monitoring must be evaluated by the CHP.

1.13.1.2 Documentation

Document employee exposure to external radiation. Include reviewing each employee's radiation exposure history in accordance with 10 CFR 20 Section 2104, for compliance with exposure standards prior to allowing the employee access to a restricted area. If the employee has no exposure history, the employee must provide a signed written statement to that effect.

1.13.1.3 Reporting

Furnish reports of exposure to ionizing radiation to the Contracting Officer as soon as available and to each employee annually, upon termination, and within 30 days of any personal request.

1.14 EVALUTAION

Document in the APP/SSHP and implement the procedures and practices in section 06.J. in EM 385-1-1 to monitor and manage heat stress.

1.15 SPILL AND DISCHARGE CONTROL

Develop and implement written spill and discharge containment/control procedures. Address radioactive wastes, shock sensitive wastes, laboratory waste packs, material handling equipment, as well as drum and container handling, opening, sampling, shipping and transport. Describe prevention measures, such as building berms or dikes; spill control measures and material to be used (e.g. booms, vermiculite); location of the spill control material; personal protective equipment required to cleanup spills; disposal of contaminated material; and who is responsible to report the spill. Storage of contaminated material or hazardous materials must be appropriately bermed, diked and/or contained to prevent any spillage of material on uncontaminated soil. If the spill or discharge is reportable, and/or human health or the environment are threatened, the National Response Center, the state, and the Contracting Officer must be notified as soon as possible.

1.16 SITE CONTROL MEASURES

1.16.1 Work Zones

Initial anticipated work zone boundaries (exclusion zone, contamination reduction zone, support zone, all access points and decontamination areas) are to be clearly delineated on the site drawings. Base delineation of work zone boundaries on the contamination characterization data and the hazard/risk analysis to be performed as described in paragraph: HAZARD/RISK ANALYSIS. As work progresses and field conditions are monitored, work zone boundaries may be modified (and site drawings modified) with approval of the Contracting Officer. Clearly identify work zones and marked in the field (using fences, tape, signs, etc.). Post a site map, showing work zone boundaries and locations of decontamination facilities in the on site office. Work zones must consist of the following:

- a. Exclusion Zone (EZ): The exclusion zone is the area where hazardous contamination is either known or expected to occur and the greatest potential for exposure exists. Control entry into this area and exit may only be made through the CRZ.
- b. Contamination Reduction Zone (CRZ): The CRZ is the transition area between the Exclusion Zone and the Support Zone. The personnel and equipment decontamination areas must be separate and unique areas located in the CRZ.
- c. Support Zone (SZ): The Support Zone is defined as areas of the site, other than exclusion zones and contamination reduction zones, where workers do not have the potential to be exposed to hazardous substances or dangerous conditions resulting from hazardous waste operations. Secure the Support Zone against active or passive contamination. Site offices, parking areas, and other support facilities must be located in the Support Zone.

d. The contractor is responsible for the designation of areas restricted due to radioactive risks.

1.16.2 Site Control Log

A log of personnel visiting, entering, or working on the site must be maintained. Include the following: date, name, agency or company, time entering and exiting site, time entering and exiting the exclusion zone (if applicable). Before visitors are allowed to enter the Contamination Reduction Zone or Exclusion Zone, they must show proof of current training, medical surveillance and respirator fit testing (if respirators are required for the tasks to be performed) and fill out a Certificate of Worker or Visitor Acknowledgment. Record this visitor information, including date, in the log.

1.16.3 Communication

Provide and install an employee alarm system that has adequate means of on and off site communication in accordance with 29 CFR 1910 Section 165. The means of communication must be able to be perceived above ambient noise or light levels by employees in the affected portions of the workplace. The signals must be distinctive and recognizable as messages to evacuate or to perform critical operations. This includes: air horns, walkie talkies, and cell phones.

1.16.4 Site Security

Provide the following site security: warning signs and fences, and site access procedures. Print signs in bold large letters on contrasting backgrounds. Signs must be visible from all points where entry might occur and at such distances from the restricted area that employees may read the signs and take necessary protective steps before entering.

1.17 PERSONAL HYGIENE AND DECONTAMINATION

Personnel entering the Exclusion or Contamination Reduction Zones or otherwise exposed to hazardous chemical vapors, gases, liquids, or contaminated solids must decontaminate themselves and their equipment prior to exiting the contamination reduction zone (CRZ) and entering the support zone. Consult Chapter 10.0 of NIOSH 85-115 when preparing decontamination procedures. Submit a detailed discussion of personal hygiene and decontamination facilities and procedures to be followed by site workers as part of the APP/SSHP. Train employees in the procedures and enforce the procedures throughout site operations.

1.17.1 Decontamination Facilities

Initially set up a decontamination line in the CRZ. Employees must exit the exclusion zone through the CRZ and implement the following decontamination procedures: removal or outerwear or tyvek as necessary and thorough inspection (Additional provisions to be included as specification is revised). Showers, if needed, must comply with 29 CFR 1910, Section 141 and EM 385-1-1, 02 C, Washing Facilities. It is the Site Safety and Health Officer's responsibility to recommend techniques to improve personnel decontamination procedures, if necessary.

1.17.2 Equipment Decontamination

Decontaminate the vehicles and equipment used in the EZ shall be decontaminated in the CRZ prior to leaving the site. 1.41.2.1 Facilities for Equipment and Personnel

Provide a vehicle/equipment decontamination station within the CRZ for decontaminating vehicles and equipment leaving the EZ. Construct a decontamination station pad, which meets the site decontamination needs for all vehicles and larger equipment decontamination. Construct the pad to capture decontamination water, including overspray, and allow for collection and removal of the decontamination water using sumps, dikes and ditches as required. Or, a dry decontamination area can be used using a broom to remove dry/loose spilled materials on accessible surfaces. Provide a designated "clean area" in the CRZ for performing equipment maintenance. Use this area when personnel are required by normal practices to come in contact with the ground, i.e., crawling under a vehicle to change engine oil. Equipment within the EZ or CRZ must be decontaminated before maintenance is performed.

1.41.2.2 Procedures

Procedures for equipment decontamination must be developed and utilized to prevent the spread of contamination into the SZ and offsite areas. These procedures must address disposal of contaminated products and spent materials used on the site, including containers, fluids, oils, etc. Assume any item taken into the EZ to be contaminated and perform an inspection and decontaminate. Vehicles, equipment, and materials must be cleaned and decontaminated prior to leaving the site. Handle construction material in such a way as to minimize the potential for contaminants being spread and/or carried offsite. Prior to exiting the site, vehicles and equipment must be monitored to ensure the adequacy of decontamination.

1.18 EMERGENCY EQUIPMENT AND FIRST AID REQUIREMENTS

Maintain, as a minimum, the following items on site and available for immediate use:

- a. First aid equipment and supplies approved by the consulting physician.
- b. Emergency eyewashes and showers that comply with ISEA Z358.1.
- c. Provide fire extinguishers of sufficient size and type at site facilities and in all vehicles and at any other site locations where flammable or combustible materials present a fire risk.

1.19 EMERGENCY RESPONSE AND CONTINGENCY PROCEDURES

An Emergency Response Plan, that meets the requirements of 29 CFR 1910.120 (l) and 29 CFR 1926.65 (l), must be developed and implemented as a section of the APP/SSHP. In the event of any emergency associated with remedial action, without delay, alert all on site employees and as necessary offsite emergency responders that there is an emergency situation; take action to remove or otherwise minimize the cause of the emergency; alert the Contracting Officer; and institute measures necessary to prevent repetition of the conditions or actions leading to, or resulting in, the emergency. Train employees that are required to respond to hazardous emergency situations to their level of responsibility according to 29 CFR 1910.120 (q) and 29 CFR 1926.65 (q) requirements. Rehearse the plan regularly as part of the overall training program for site operations. Review the plan periodically and revised as necessary to reflect new or

changing site conditions or information. Provide copies of the Emergency Response Portion of the accepted APP/SSHP to the affected local emergency response agencies. Address, as a minimum, the following elements in the plan:

- a. Pre-emergency planning. Coordinate with local emergency response providers during preparation of the Emergency Response Plan. At a minimum, coordinate with local fire, rescue, hazardous materials response teams, police and emergency medical providers to assure all organizations are capable and willing to respond to and provide services for on-site emergencies. Ensure the Emergency Response Plan for the site is compatible and integrated with the local fire, rescue, medical and police security services available from local emergency response planning agencies.
- b. Personnel roles, lines of authority, communications for emergencies.
- c. Emergency recognition and prevention.
- d. Site topography, layout, and prevailing weather conditions.
- e. Criteria and procedures for site evacuation (emergency alerting procedures, employee alarm system, emergency PPE and equipment, safe distances, places of refuge, evacuation routes, site security and control).
- f. Specific procedures for decontamination and medical treatment of injured personnel.
- g. Route maps to nearest prenotified medical facility. Site-support vehicles must be equipped with maps. At the beginning of project operations, drivers of the support vehicles must become familiar with the emergency route and the travel time required.
- h. Emergency alerting and response procedures including posted instructions and a list of names and telephone numbers of emergency contacts (physician, nearby medical facility, fire and police departments, ambulance service, Federal, state, and local environmental agencies; as well as Safety and Health Manager, the Site Superintendent, the Contracting Officer and/or their alternates).
- i. Criteria for initiating community alert program, contacts, and responsibilities.
- j. Procedures for reporting incidents to appropriate government agencies. In the event that an incident such as an explosion or fire, or a spill or release of toxic materials occurs during the course of the project, the appropriate government agencies must be immediately notified. In addition, verbally notify the Contracting Officer and the local district safety office immediately and receive a written notification within 24 hours. Include within the report the following items:
 - (1) Name, organization, telephone number, and location of the Contractor.
 - (2) Name and title of the person(s) reporting.
 - (3) Date and time of the incident.

- (4) Location of the incident, i.e., site location, facility name.
 - (5) Brief summary of the incident giving pertinent details including type of operation ongoing at the time of the incident.
 - (6) Cause of the incident, if known.
 - (7) Casualties (fatalities, disabling injuries).
 - (8) Details of any existing chemical hazard or contamination.
 - (9) Estimated property damage, if applicable.
 - (10) Nature of damage, effect on contract schedule.
 - (11) Action taken to ensure safety and security.
 - (12) Other damage or injuries sustained, public or private.
- k. Procedures for critique of emergency responses and follow-up.

1.20 CERTIFICATE OF WORKER/VISITOR ACKNOWLEDGEMENT

A copy of a Contractor-generated certificate of worker/visitor acknowledgement must be completed and submitted for each visitor allowed to enter contamination reduction or exclusion zones, and for each employee, following the example certificate at the end of this section.

1.21 INSPECTIONS

Attach to and submit with the Daily Quality Control reports the SSHO's Daily Inspection Logs. Include with each entry the following: date, work area checked, employees present in work area, PPE and work equipment being used in each area, special safety and health issues and notes, and signature of preparer.

1.22 SAFETY AND HEALTH PHASE-OUT REPORT

Submit a Safety and Health Phase-Out Report in conjunction with the project close out report and will be received prior to final acceptance of the work. Include the following minimum information:

- a. Summary of the overall performance of safety and health (accidents or incidents including near misses, unusual events, lessons learned, etc.).
- b. Final decontamination documentation including procedures and techniques used to decontaminate equipment, vehicles, and on site facilities.
- c. Summary of exposure monitoring and air sampling accomplished during the project.

IR SITES 7 AND 18
COVER AND REVETMENT
HUNTERS POINT SHIPYARD

05-29-2009

d. Signatures of Safety and Health Manager and SSHO.

Task Hazard and Control Requirements Sheets.

PART 2 PRODUCTS (Not Applicable)

PART 3 EXECUTION (Not Applicable)

END OF SECTION

01 35 29.13-18

HEALTH, SAFETY, AND EMERGENCY RESPONSE

**SECTION 01 45 02
QUALITY CONTROL**

PART 1 GENERAL

1.1 REFERENCES

The publications listed below form a part of this specification to the extent referenced. The publications are referred to in the text by the basic designation only.

AMERICAN SOCIETY FOR TESTING AND MATERIALS (ASTM)

ASTM D 3740 (2008) Agencies Engaged in the Testing and/or Inspection of Soil and Rock as Used in Engineering Design and Construction

ASTM E 329 (2008) Agencies Engaged in the Testing and/or Inspection of Materials used on Construction

1.2 SUBMITTALS

Submit the following in accordance with Section 01 33 00 Submittal Procedures.

1.2.1 SD-01, Preconstruction Submittal

- a. Quality Control (QC) plan; G

1.3 INFORMATION FOR THE CONTRACTING OFFICER

Deliver the following to the Contracting Officer:

- a. Combined Contractor Production Report/Contractor Quality Control Report (1 sheet): Original and 1 copy by 10:00 a.m. the next working day after each day that work is performed;
- b. QC Specialist Reports: Originals and 1 copy by 10:00 a.m. the next working day after each day that work is performed, attached to the Contractor Quality Control Report;
- c. Field Test Reports: 2 copies, within 2 working days after the test is performed, attached to the Contractor Quality Control Report;
- d. Monthly Summary Report of Tests: 2 copies attached to the Contractor Quality Control Report;
- e. Testing Plan and Log, 2 copies, at the end of each month;
- f. Rework Items List: 2 copies, by the last working day of the month
- g. QC Meeting Minutes: 2 copies, within 2 working days after the meeting and;

01 45 02-1

QUALITY CONTROL

h. QC Certifications: As required by the paragraph titled "QC Certifications."

1.4 QC PROGRAM REQUIREMENTS

The QC program requirements are contained in the Remedial Action Contract (RAC).

1.5 QC ORGANIZATION

1.5.1 QC Manager

1.5.1.1 Duties

Provide a QC Manager at the work site to implement and manage the QC program. In addition to implementing and managing the QC program, the QC Manager may perform the duties of project superintendent.

The QC Manager is required to attend the Coordination and Mutual Understanding Meeting, conduct the QC meetings, perform the three phases of control, perform submittal review, perform submittal approval, ensure testing is performed, and provide QC certifications and documentation required in this Contract. The QC Manager is responsible for managing and coordinating the three phases of control and documentation performed by Testing Laboratory personnel and any other inspection and testing personnel required by this contract.

1.5.1.2 Qualifications

An individual with a minimum of 5 years experience as a superintendent, inspector, QC Manager, project manager, or construction manager on similar size and type construction contracts that included the major trades that are part of this Contract.

1.6 QUALITY CONTROL (QC) PLAN

1.6.1 Requirements

Provide for approval by the Contracting Officer, a QC plan submitted in accordance with the requirements of the RAC.

1.7 COORDINATION AND MUTUAL UNDERSTANDING MEETING

After submission of the QC Plan and prior to the start of construction, meet with the Contracting Officer to present the QC program required by this Contract. The purpose of this meeting is to develop a mutual understanding of the QC details, including documentation, administration for on-site and off-site work, and the coordination of the Contractor's management, production, and QC personnel. At the meeting, the Contractor will be required to explain in detail how the three phases of control will be implemented for each definable feature of work. As a minimum, the Contractor's personnel required to attend shall include an officer of the firm, the project manager, project superintendent, QC Manager, Architectural

Engineering (A/E) Firm, and subcontractor representatives. Each subcontractor who will be assigned QC responsibilities shall have a principal of the firm at the meeting. Minutes of the meeting will be prepared by the QC Manager and signed by the Contractor, the A/E, and the Contracting Officer. A copy of the signed minutes shall be provided to all attendees by the Contractor.

1.8 QC MEETINGS

After the start of construction, the QC Manager shall conduct weekly QC meetings at the work site with the project superintendent. The QC Manager shall prepare the minutes of the meeting and provide a copy to the Contracting Officer within 2 working days after the meeting. The Contracting Officer may attend these meetings. The QC Manager shall notify the Contracting Officer at least 48 hours in advance of each meeting. As a minimum, the following shall be accomplished at each meeting:

- a. Review the minutes of the previous meeting;
- b. Review the schedule and the status of work:
 - Work or testing accomplished since last meeting;
 - Rework items identified since last meeting;
 - Rework items completed since last meeting;
- c. Review the status of submittals:
 - Submittals reviewed and approved since last meeting;
 - Submittals required in the near future;
- d. Review the work to be accomplished in the next 2 weeks and the documentation required:
 - Establish completion dates for rework items
 - Update the schedule showing planned and actual dates of the preparatory, initial, and follow-up phases, including testing and any other inspection required by this Contract
 - Discuss construction methods and the approach that will be used to provide quality construction by planning ahead and identifying potential problems for each definable feature of work
 - Discuss status of off-site work or testing
 - Documentation required;
- e. Resolve QC and production problems:

- Assist in resolving Request for Information issues; and
- f. Address items that may require revising the QC plan:
 - Changes in QC organization personnel
 - Changes in procedures.

1.9 THREE PHASES OF CONTROL

The three phases of control shall adequately cover both on-site and off-site work and shall include the following for each definable feature of work.

1.9.1 Preparatory Phase

Notify the Contracting Officer at least 1 work day in advance of each preparatory phase. Conduct the preparatory phase with the superintendent and the foreman responsible for the definable feature. Document the results of the preparatory phase actions in the daily Contractor Quality Control Report and in the Quality Control Checklist. Perform the following prior to beginning work on each definable feature of work:

- a. Review each paragraph of the applicable specification sections;
- b. Review the Contract Drawings;
- c. Verify that appropriate shop Drawings and submittals have been submitted and approved. Verify receipt of approved factory test results, when required;
- d. Review the testing plan and ensure that provisions have been made to provide the required QC testing;
- e. Examine the work area to ensure that the required preliminary work has been completed;
- f. Examine the required materials, equipment, and sample work to ensure that they are on hand and conform to the approved shop Drawings and submitted data;
- g. Review the safety plan and appropriate activity hazard analysis to ensure that applicable safety requirements are met, and that required Material Safety Data Sheets (MSDS) are submitted; and
- h. Discuss construction methods and the approach that will be used to provide quality construction for each definable feature of work.

1.9.2 Initial Phase

Notify the Contracting Officer at least 1 work day in advance of each initial phase. When construction crews are ready to start work on a definable feature of work, conduct the initial

01 45 02-4

phase with the superintendent and the foreman responsible for that definable feature of work. Observe the initial segment of the definable feature of work to ensure that the work complies with Contract requirements. Document the results of the initial phase in the daily Contractor Quality Control Report and in the Quality Control Checklist. Repeat the initial phase for each new crew to work on site, or when acceptable levels of specified quality are not being met. Perform the following for each definable feature of work:

- a. Establish the quality of workmanship required;
- b. Resolve conflicts;
- c. Review the Safety Plan and the appropriate activity hazard analysis to ensure that applicable safety requirements are met; and
- d. Ensure that testing is performed.

1.9.3 Follow-up Phase

Perform the following for on-going work daily, until the completion of each definable feature of work and document in the daily Contractor Quality Control Report and in the Quality Control Checklist:

- a. Ensure the work is in compliance with Contract requirements;
- b. Maintain the quality of workmanship required;
- c. Ensure that testing is performed; and
- d. Ensure that rework items are being corrected.

1.10 SUBMITTAL REVIEW AND APPROVAL

Procedures for submission, review, and approval of submittals are described in the RAC.

1.11 TESTING

Except as stated otherwise in the specification sections, perform sampling and testing required under this Contract.

1.11.1 Testing Laboratory Requirements

Provide an independent testing laboratory qualified to perform sampling and tests required by this Contract. When the proposed testing laboratory is not accredited by an acceptable accreditation program as described by the paragraph titled "Accredited Laboratories," submit to the Contracting Officer for approval, certified statements signed by an official of the testing laboratory attesting that the proposed laboratory meets or conforms to the following requirements:

- a. Laboratories engaged in testing of construction materials shall meet the requirements of ASTM E 329.
- b. Laboratories engaged in testing of soil and rock, as used in engineering design and construction, shall meet the requirements of ASTM D 3740.

1.11.2 Accredited Laboratories

In addition to applicable U.S. Navy approval through the Naval Facilities Engineering Service Center (NFESC), acceptable accreditation programs are the National Institute of Standards and Technology (NIST)/National Voluntary Laboratory Accreditation Program (NVLAP), the American Association of State Highway and Transportation Officials (AASHTO) program, and the American Association for Laboratory Accreditation (A2LA) program. Furnish to the Contracting Officer a copy of the Certificate of Accreditation and Scope of Accreditation and latest directory of the accrediting organization for accredited laboratories. The scope of the laboratory's accreditation shall include the test methods required by the Contract.

1.11.3 Inspection of Testing Laboratories

Prior to approval of non-accredited laboratories, the proposed testing laboratory facilities and records may be subject to inspection by the Contracting Officer. Records subject to inspection include equipment inventory, equipment calibration dates and procedures, library of test procedures, audit and inspection reports by agencies conducting laboratory evaluations and certifications, testing and management personnel qualifications, test report forms, and the internal QC procedures.

1.11.4 Capability Check

The Contracting Officer retains the right to check laboratory equipment in the proposed laboratory and the laboratory technician's testing procedures, techniques, and other items pertinent to testing, for compliance with the standards set forth in this Contract.

1.11.5 Test Results

Cite applicable Contract requirements, tests, or analytical procedures used. Provide actual results and include a statement that the item tested or analyzed conforms or fails to conform to specified requirements. If item fails to conform, notify Contracting Officer immediately. Conspicuously stamp the cover sheet for each report in large red letters "CONFORMS" or "DOES NOT CONFORM" to the specification requirements, whichever is applicable. Test results shall be signed by a testing laboratory representative authorized to sign certified test reports. Furnish the signed reports, certifications, and other documentation to the Contracting Officer via the QC Manager. Furnish a summary report of field tests at the end of each month. Attach a copy of the summary report to the last daily Contractor Quality Control Report of each month.

1.11.6 Test Reports and Monthly Summary Report of Tests

The QC Manager shall furnish the signed reports, certifications, and a summary report of field

tests at the end of each month to the Contracting Officer. Attach a copy of the summary report to the last daily Contractor Quality Control Report of each month.

1.12 QC CERTIFICATIONS

1.12.1 Contractor Quality Control Report Certification

Each Contractor Quality Control Report shall contain the following statement: "On behalf of the Contractor, I certify that this report is complete and correct and equipment and material used and work performed during this reporting period is in compliance with the contract Drawings and specifications to the best of my knowledge, except as noted in this report."

1.12.2 Invoice Certification

Furnish a certificate to the Contracting Officer with each payment request, signed by the QC Manager, attesting that as-built Drawings are current and attesting that the work for which payment is requested, including stored material, is in compliance with contract requirements.

1.12.3 Completion Certification

Upon completion of work under this Contract, the QC Manager shall furnish a certificate to the Contracting Officer attesting that "the work has been completed, inspected, tested, and is in compliance with the Contract."

1.13 DOCUMENTATION

Maintain current and complete records of on-site and off-site QC program operations and activities.

1.13.1 Contractor Production Report

Reports are required for each day that work is performed and shall be attached to the Contractor Quality Control Report prepared for the same day. Account for each calendar day throughout the life of the Contract. The reporting of work shall be identified by terminology consistent with the construction schedule. Contractor Production Reports are to be prepared, signed, and dated by the project superintendent and shall contain the following information:

- a. Date of report, report number, name of contractor, Contract number, title and location of Contract, and superintendent present.
- b. Weather conditions in the morning and in the afternoon including maximum and minimum temperatures.
- c. A list of Contractor and subcontractor personnel on the work site, their trades, employer, work location, description of work performed, and hours worked.
- d. A list of job safety actions taken and safety inspections conducted. Indicate that safety requirements have been met including the results on the following:

- Attach a copy of the meeting minutes from the daily job safety meeting.
 - Were there any lost time accidents? (If YES, attach a copy of the completed Occupational Safety and Health Administration report.)
 - Was crane/trenching/scaffold/high voltage electrical/high work done? (If YES, attach a statement or checklist showing inspection performed.)
 - Was hazardous material/waste released into the environment? (If YES, attach a description of meetings held and accidents that happened.)
- e. A list of equipment/material received each day that is incorporated into the job.
- f. A list of construction and plant equipment on the work site including the number of hours used, idle, and down for repair.
- g. Include a "remarks" section in this report which will contain pertinent information including directions received, problems encountered during construction, work progress and delays, conflicts or errors in the Drawings or specifications, field changes, safety hazards encountered, instructions given and corrective actions taken, delays encountered, and a record of visitors to the work site.

1.13.2 Contractor Quality Control Report

Reports are required for each day that work is performed and for every 7 consecutive calendar days of no work and on the last day of a no-work period. Account for each calendar day throughout the life of the Contract. The reporting of work shall be identified by terminology consistent with the construction schedule. Contractor Quality Control Reports are to be prepared, signed, and dated by the QC Manager, and shall contain the following information:

- a. Identify the control phase and the definable feature of work.
- b. Results of the Preparatory Phase meetings held including the location of the definable feature of work and a list of personnel present at the meeting. Indicate in the report that, for this definable feature of work, the Drawings and specifications have been reviewed, submittals have been approved, materials comply with approved submittals, materials are stored properly, preliminary work was done correctly, the testing plan has been reviewed, and work methods and schedule have been discussed.
- c. Results of the Initial Phase meetings held including the location of the definable feature of work and a list of personnel present at the meeting. Indicate in the report that for this definable feature of work the preliminary work was done correctly, samples have been prepared and approved, the workmanship is satisfactory, test results are acceptable, work is in compliance with the Contract, and the required testing has been performed, and include a list of who performed the tests.
- d. Results of the Follow-up Phase inspections held including the location of the definable feature of work. Indicate in the report for this definable feature of work that the work complies with the Contract as approved in the Initial Phase, and that required testing has been performed, and include a list of who performed the tests.

- e. Results of the three phases of control for off-site work, if applicable, including actions taken.
- f. List the rework items identified, but not corrected, by close of business.
- g. List the rework items corrected from the rework items list along with the corrective action taken.
- h. Include a “remarks” section in this report that will contain pertinent information including directions received, quality control problem areas, deviations from the QC plan, construction deficiencies encountered, QC meetings held, acknowledgment that as-built Drawings have been updated, corrective direction given by the QC Organization, and corrective action taken by the Contractor.
- i. Contractor Quality Control Report certification.

1.13.3 Testing Plan and Log

As tests are performed, the QC Manager shall record on the “Testing Plan and Log” the date the test was conducted, the date the test results were forwarded to the Contracting Officer, remarks, and acknowledgment that an accredited or Contracting Officer-approved testing laboratory was used. Attach a copy of the updated “Testing Plan and Log” to the last daily Contractor Quality Control Report of each month.

1.13.4 Rework Items List

The QC Manager shall maintain a list of work that does not comply with the Contract, identifying what items need to be reworked, the date the item was originally discovered, and the date the item was corrected. There is no requirement to report a rework item that is corrected the same day it is discovered. Attach a copy of the “Contractor Rework Items List” to the last daily Contractor Quality Control Report of each month. The Contractor shall be responsible for including on this list items needing rework, including those identified by the Contracting Officer.

1.13.5 As-Built Drawings

The QC Manager is required to review the as-built Drawings to ensure that as-built Drawings are kept current on a daily basis and marked to show deviations that have been made from the Contract Drawings. The QC Manager shall initial each deviation and each revision. Upon completion of work, the QC Manager shall furnish a certificate attesting to the accuracy of the as-built Drawings prior to submission to the Contracting Officer.

1.13.6 Report Forms

The following forms, which are attached at the end of this section, are acceptable for providing the information required by the paragraph titled “Documentation.” While use of these specific formats is not required, any other format used shall contain the same information:

01 45 02-9

- a. Combined Contractor Production Report and Contractor Quality Control Report
(1 sheet), with separate continuation sheet
- b. Testing Plan and Log
- c. Rework Items List

PART 2 PRODUCTS

Not used.

PART 3 EXECUTION

Not used.

END OF SECTION

CONTRACTOR QUALITY CONTROL REPORT

(ATTACH ADDITIONAL SHEETS IF NECESSARY)

| | |
|-----------|-------------------|
| DATE | Enter (DD/MMM/YY) |
| REPORT NO | Enter Rpt # Here |

| | | |
|-------|-----------------------------|---|
| PHASE | CONTRACT NO Enter Cnt# Here | CONTRACT TITLE Enter Title and Location of Construction Contract Here |
|-------|-----------------------------|---|

| | | |
|--------------------|--|---------------------------|
| PREPARATORY | WAS PREPARATORY PHASE WORK PREFORMED TODAY? YES <input type="checkbox"/> NO <input type="checkbox"/> | |
| | IF YES, FILL OUT AND ATTACH SUPPLEMENTAL PREPARATORY PHASE CHECKLIST. | |
| | Schedule Activity No. | Definable Feature of Work |
| | | Index # |
| | | |

| | | |
|----------------|--|---------------------------|
| INITIAL | WAS INITIAL PHASE WORK PREFORMED TODAY? YES <input type="checkbox"/> NO <input type="checkbox"/> | |
| | IF YES, FILL OUT AND ATTACH SUPPLEMENTAL INITIAL PHASE CHECKLIST. | |
| | Schedule Activity No. | Definable Feature of Work |
| | | Index # |
| | | |

| | | |
|------------------|--|--|
| FOLLOW-UP | WORK COMPLIES WITH CONTRACT AS APPROVED DURING INITIAL PHASE? YES <input type="checkbox"/> NO <input type="checkbox"/> | |
| | WORK COMPLIES WITH SAFETY REQUIREMENTS? YES <input type="checkbox"/> NO <input type="checkbox"/> | |
| | Schedule Activity No. | Description of Work, Testing Performed & By Whom, Definable Feature of Work, Specification Section, Location and List of Personnel Present |
| | | |
| | | |
| | | |
| | | |
| | | |
| | | |
| | | |

| REWORK ITEMS IDENTIFIED TODAY (NOT CORRECTED BY CLOSE OF BUSINESS) | | REWORK ITEMS CORRECTED TODAY (FROM REWORK ITEMS LIST) | |
|--|-------------|---|-------------|
| Schedule Activity No. | Description | Schedule Activity No. | Description |
| | | | |
| | | | |
| | | | |

| | |
|---|-------------|
| REMARKS (Also Explain Any Follow-Up Phase Checklist Item From Above That Was Answered "NO"), Manuf. Rep On-Site, etc. | |
| Schedule Activity No. | Description |
| | |
| | |
| | |

On behalf of the contractor, I certify that this report is complete and correct and equipment and material used and work performed during this reporting period is in compliance with the contract drawings and specifications to the best of my knowledge except as noted in this report.

 AUTHORIZED QC MANAGER AT SITE DATE

GOVERNMENT QUALITY ASSURANCE REPORT

DATE

| | |
|--|-------------|
| QUALITY ASSURANCE REPRESENTATIVE'S REMARKS AND/OR EXCEPTIONS TO THE REPORT | |
| Schedule Activity No. | Description |
| | |
| | |
| | |

PREPARATORY PHASE CHECKLIST

(CONTINUED ON SECOND PAGE)

SPEC SECTION

Enter Spec Section # Here

DATE

Enter Date (DD/MMM/YY)

CONTRACT NO

Enter Cnt# Here

DEFINABLE FEATURE OF WORK

Enter DFOV Here

SCHEDULE ACT NO.

Enter Sched Act ID Here

INDEX #

Enter Index# Here

| | |
|---------------------------------------|--|
| PERSONNEL PRESENT | GOVERNMENT REP NOTIFIED _____ HOURS IN ADVANCE: YES <input type="checkbox"/> NO <input type="checkbox"/> NAME _____ POSITION _____ COMPANY/GOVERNMENT _____ |
| | |
| | |
| | |
| | |
| | |
| | |
| SUBMITTALS | REVIEW SUBMITTALS AND/OR SUBMITTAL REGISTER. HAVE ALL SUBMITTALS BEEN APPROVED? YES <input type="checkbox"/> NO <input type="checkbox"/> IF NO, WHAT ITEMS HAVE NOT BEEN SUBMITTED? _____ |
| | ARE ALL MATERIALS ON HAND? YES <input type="checkbox"/> NO <input type="checkbox"/> IF NO, WHAT ITEMS ARE MISSING? _____ |
| | CHECK APPROVED SUBMITTALS AGAINST DELIVERED MATERIAL. (THIS SHOULD BE DONE AS MATERIAL ARRIVES.) COMMENTS: _____ |
| | |
| | |
| MATERIAL STORAGE | ARE MATERIALS STORED PROPERLY? YES <input type="checkbox"/> NO <input type="checkbox"/> IF NO, WHAT ACTION IS TAKEN? _____ |
| | |
| | |
| | |
| SPECIFICATIONS | REVIEW EACH PARAGRAPH OF SPECIFICATIONS. _____ |
| | |
| | DISCUSS PROCEDURE FOR ACCOMPLISHING THE WORK. _____ |
| | |
| | CLARIFY ANY DIFFERENCES. _____ |
| PRELIMINARY WORK & PERMITS | ENSURE PRELIMINARY WORK IS CORRECT AND PERMITS ARE ON FILE. IF NOT, WHAT ACTION IS TAKEN? _____ |
| | |
| | |
| | |

| | |
|--|--|
| TESTING | IDENTIFY TEST TO BE PERFORMED, FREQUENCY, AND BY WHOM. _____ |
| | |
| | |
| | WHEN REQUIRED? _____ |
| | |
| | |
| | |
| WHERE REQUIRED? _____ | |
| | |
| | |
| REVIEW TESTING PLAN. _____ | |
| | |
| | |
| HAS TEST FACILITIES BEEN APPROVED? _____ | |
| | |
| | |
| SAFETY | ACTIVITY HAZARD ANALYSIS APPROVED? YES <input type="checkbox"/> NO <input type="checkbox"/> |
| | REVIEW APPLICABLE PORTION OF EM 385-1-1. _____ |
| | |
| MEETING COMMENTS | NAVY/ROICC COMMENTS DURING MEETING. |
| | |
| | |
| | |
| | |
| | |
| | |
| OTHER ITEMS OR REMARKS | OTHER ITEMS OR REMARKS: |
| | |
| | |
| | |
| | |
| | |
| | |
| <div style="display: flex; justify-content: space-around;"> QC MANAGER _____ DATE _____ </div> | |

| CONTRACTOR PRODUCTION REPORT <small>(ATTACH ADDITIONAL SHEETS IF NECESSARY)</small> | | | | DATE | |
|--|-------------------------------|---|---|--|---|
| CONTRACT NO <small>Enter Cnt# Here</small> | | TITLE AND LOCATION <small>Enter Title and Location of Construction Contract Here</small> | | REPORT NO <small>Enter Report # Here</small> | |
| CONTRACTOR <small>Enter The Contractor's Company Name Here</small> | | | SUPERINTENDENT <small>Enter Superintendent's Name Here</small> | | |
| AM WEATHER <small>Enter AM Weather Data Here</small> | | PM WEATHER <small>Enter PM Weather Data Here</small> | | MAX TEMP (F) <small>Enter Max Temp Here</small> | MIN TEMP (F) <small>Enter Min Temp Here</small> |
| WORK PERFORMED TODAY | | | | | |
| Schedule Activity No. | WORK LOCATION AND DESCRIPTION | EMPLOYER | NUMBER | TRADE | HRS |
| | | | | | |
| | | | | | |
| | | | | | |
| | | | | | |
| | | | | | |
| | | | | | |
| | | | | | |
| | | | | | |
| | | | | | |
| | | | | | |
| | | | | | |
| | | | | | |
| | | | | | |
| | | | | | |
| JOB SAFETY | | WAS A JOB SAFETY MEETING HELD THIS DATE? <small>(If YES attach copy of the meeting minutes)</small> | | <input type="checkbox"/> YES <input type="checkbox"/> NO | |
| | | WERE THERE ANY LOST TIME ACCIDENTS THIS DATE? <small>(If YES attach copy of completed OSHA report)</small> | | <input type="checkbox"/> YES <input type="checkbox"/> NO | |
| WAS CRANE/MANLIFT/TRENCHING/SCAFFOLD/HV ELEC/HIGH WORK/ HAZMAT WORK DONE? <small>(If YES attach statement or checklist showing inspection performed.)</small> | | <input type="checkbox"/> YES <input type="checkbox"/> NO | | TOTAL WORK HOURS ON JOB SITE, THIS DATE, INCL CON'T SHEETS | |
| WAS HAZARDOUS MATERIAL/WASTE RELEASED INTO THE ENVIRONMENT? <small>(If YES attach description of incident and proposed action.)</small> | | <input type="checkbox"/> YES <input type="checkbox"/> NO | | CUMULATIVE TOTAL OF WORK HOURS FROM PREVIOUS REPORT | |
| Schedule Activity No. | | LIST SAFETY ACTIONS TAKEN TODAY/SAFETY INSPECTIONS CONDUCTED | | | <input type="checkbox"/> SAFETY REQUIREMENTS HAVE BEEN MET. |
| | | | | | |
| | | | | | |
| | | | | | |
| | | | | | |
| EQUIPMENT/MATERIAL RECEIVED TODAY TO BE INCORPORATED IN JOB (INDICATE SCHEDULE ACTIVITY NUMBER) | | | | | |
| Schedule Activity No. | Submittal # | Description of Equipment/Material Received | | | |
| | | | | | |
| | | | | | |
| | | | | | |
| | | | | | |
| | | | | | |
| | | | | | |
| | | | | | |
| | | | | | |
| CONSTRUCTION AND PLANT EQUIPMENT ON JOB SITE TODAY. INDICATE HOURS USED AND SCHEDULE ACTIVITY NUMBER. | | | | | |
| Schedule Activity No. | Owner | Description of Construction Equipment Used Today (incl Make and Model) | | | Hours Used |
| | | | | | |
| | | | | | |
| | | | | | |
| | | | | | |
| | | | | | |
| | | | | | |
| | | | | | |
| | | | | | |
| | | | | | |
| Schedule Activity No. | REMARKS | | | | |
| | | | | | |
| | | | | | |
| | | | | | |
| | | | | | |
| | | | | | |
| | | | | | |
| | | | | | |
| | | | | | |
| | | | | | |
| | | | | | |
| _____ CONTRACTOR/SUPERINTENDENT | | | _____ DATE | | |

| INITIAL PHASE CHECKLIST | | SPEC SECTION Enter Spec Section # Here | DATE Enter Date (DD/MMM/YY) |
|--------------------------------|--|---|--|
| CONTRACT NO Enter Cnt# Here | DEFINABLE FEATURE OF WORK Enter DFOW Here | SCHEDULE ACT NO. Enter Sched Act ID Here | INDEX # Enter Index# Here |
| PERSONNEL PRESENT | GOVERNMENT REP NOTIFIED _____ HOURS IN ADVANCE: | | YES <input type="checkbox"/> NO <input type="checkbox"/> |
| | NAME | POSITION | COMPANY/GOVERNMENT |
| | | | |
| | | | |
| | | | |
| | | | |
| PROCEDURE COMPLIANCE | IDENTIFY FULL COMPLIANCE WITH PROCEDURES IDENTIFIED AT PREPARATORY. COORDINATE PLANS, SPECIFICATIONS, AND SUBMITTALS. | | |
| | COMMENTS: _____ | | |
| | | | |
| PRELIMINARY WORK | ENSURE PRELIMINARY WORK IS COMPLETE AND CORRECT. IF NOT, WHAT ACTION IS TAKEN? | | |
| | | | |
| | | | |
| | | | |
| WORKMANSHIP | ESTABLISH LEVEL OF WORKMANSHIP. | | |
| | WHERE IS WORK LOCATED? _____ | | |
| | | | |
| | IS SAMPLE PANEL REQUIRED? YES <input type="checkbox"/> NO <input type="checkbox"/> | | |
| | WILL THE INITIAL WORK BE CONSIDERED AS A SAMPLE? YES <input type="checkbox"/> NO <input type="checkbox"/> (IF YES, MAINTAIN IN PRESENT CONDITION AS LONG AS POSSIBLE AND DESCRIBE LOCATION OF SAMPLE) _____ | | |
| RESOLUTION | RESOLVE ANY DIFFERENCES. | | |
| | COMMENTS: _____ | | |
| | | | |
| | | | |
| CHECK SAFETY | REVIEW JOB CONDITIONS USING EM 385-1-1 AND JOB HAZARD ANALYSIS | | |
| | COMMENTS: _____ | | |
| | | | |
| | | | |
| OTHER | OTHER ITEMS OR REMARKS | | |
| | | | |
| | | | |
| _____ QC MANAGER | | _____ DATE | |

REWORK ITEMS LIST

Contract No. and Title: Enter Contract # and Title Here

Contractor: Enter Contractor's Company Name Here

| NUMBER | DATE IDENTIFIED | DESCRIPTION | CONTRACT REQUIREMENT (Spec. Section and Par. No., Drawing No. and Detail No., etc.) | ACTION TAKEN BY QC MANAGER | RESOLUTION | DATE COMPLETED |
|--------|-----------------|-------------|--|----------------------------|------------|----------------|
| | | | | | | |
| | | | | | | |
| | | | | | | |
| | | | | | | |
| | | | | | | |
| | | | | | | |
| | | | | | | |
| | | | | | | |
| | | | | | | |
| | | | | | | |
| | | | | | | |
| | | | | | | |
| | | | | | | |
| | | | | | | |
| | | | | | | |
| | | | | | | |
| | | | | | | |
| | | | | | | |
| | | | | | | |
| | | | | | | |
| | | | | | | |

TESTING PLAN AND LOG

| CONTRACT NUMBER Enter Contract # Here | | | PROJECT TITLE AND LOCATION Enter Contract Title and Location Here | | | | | | | CONTRACTOR Enter Contractor's Company Name Here | |
|--|--------------|---------------|--|----|------------|-----------|------------------|----------|----------------|--|---------|
| SPECIFICATION SECTION AND PARAGRAPH NUMBER | ITEM OF WORK | TEST REQUIRED | ACCREDITED/ APPROVED LAB | | SAMPLED BY | TESTED BY | LOCATION OF TEST | | DATE COMPLETED | DATE FORWARDED TO CONTR. OFF. | REMARKS |
| | | | YES | NO | | | ON SITE | OFF SITE | | | |
| | | | | | | | | | | | |
| | | | | | | | | | | | |
| | | | | | | | | | | | |
| | | | | | | | | | | | |
| | | | | | | | | | | | |
| | | | | | | | | | | | |
| | | | | | | | | | | | |
| | | | | | | | | | | | |
| | | | | | | | | | | | |
| | | | | | | | | | | | |
| | | | | | | | | | | | |
| | | | | | | | | | | | |
| | | | | | | | | | | | |
| | | | | | | | | | | | |
| | | | | | | | | | | | |
| | | | | | | | | | | | |
| | | | | | | | | | | | |
| | | | | | | | | | | | |
| | | | | | | | | | | | |
| | | | | | | | | | | | |
| | | | | | | | | | | | |
| | | | | | | | | | | | |
| | | | | | | | | | | | |
| | | | | | | | | | | | |
| | | | | | | | | | | | |
| | | | | | | | | | | | |
| | | | | | | | | | | | |
| | | | | | | | | | | | |
| | | | | | | | | | | | |
| | | | | | | | | | | | |
| | | | | | | | | | | | |

SECTION 01 50 00
TEMPORARY FACILITIES AND CONTROLS

PART 1 GENERAL

1.1 REFERENCES

FEDERAL HIGHWAY ADMINISTRATION (FHWA)

Manual on Uniform Traffic Control Devices (FHWA MUTCD) (1988)

1.2 SUBMITTALS

Submit the following in accordance with Section 01 33 00 Submittal Procedures.

1.2.1 SD-02 Drawings

- a. Traffic control plan; G
- b. Project sign

1.3 TEMPORARY UTILITIES

The Contractor shall coordinate any utility hookups that may be needed for the project, including water, electricity, and telephone services.

1.4 TEMPORARY SANITARY FACILITIES

Provide adequate sanitary conveniences of a type approved for the use of persons employed on the work, properly secluded from public observation, and maintained in such a manner as required or approved by the Contracting Officer. Maintain these conveniences at all times without nuisance. Upon completion of the work, remove the conveniences from the premises, leaving the premises clean and free from nuisance.

1.5 TEMPORARY BUILDINGS AND CONSTRUCTION EQUIPMENT

Locations of the Contractor staging area shall be approved by the Contracting Officer. The trailers or storage buildings shall be suitably painted and kept in a good state of repair. A sign not smaller than 24 inches by 24 inches shall be conspicuously placed on the trailer depicting the company name, business phone number, and emergency phone number. Trailers shall be anchored to resist high winds and seismic loads, and must meet applicable state or local standards for anchoring mobile trailers.

1.6 IDENTIFICATION OF CONTRACTOR VEHICLES

Each Contractor-provided vehicle and towed trailer shall show the Contractor's name so that it is clearly visible from at least 100 feet on both front doors of the vehicle and both sides of a towed trailer. Removable company identification is acceptable. Contractor-provided vehicle shall at all times display a valid state license plate and safety inspection sticker. Contractor vehicles operated on Government property shall be maintained in a good state of repair.

1.7 PROJECT SIGN

Within 15 days after the commencement of work, provide one project identification sign at a location indicated by the Contracting Officer. Construct the sign in accordance with project sign detail attached at the end of this section. Maintain sign throughout the life of the project. Upon completion of the project, remove the sign from the site.

1.7.1 Project Identification Signboard

A project identification signboard shall be provided in accordance with attached Plate 1, except the word "ARCHITECT" shall be replaced by the word "ENGINEER." The signboard shall be provided at a conspicuous location on or near the job site where directed by the Contracting Officer. Construct signboard in accordance with project identification signboard Plates 3 and 4.

- a. The field of the sign shall consist of a 4- by 8- foot sheet of grade B-B, medium-density overlaid exterior plywood.
- b. Lumber shall be B or better Southern pine, pressure-preservative treated with pentachlorophenol. Nails shall be aluminum or galvanized steel.
- c. The entire signboard and supports shall be given one coat of exterior alkyd primer and two coats of exterior alkyd enamel paint. The lettering and sign work shall be performed by a skilled sign painter using paint known in the trade as bulletin colors. The colors, lettering sizes, and lettering styles shall be as indicated. Where preservative-treated lumber is required, use only cured pressure-treated wood that has had the chemicals leached from the surface of the wood prior to painting.
- d. The high-gloss acrylic gold enamel paint used as background for the Department of the Navy-applied sticker shall be spray applied automotive quality paint. The 18-inch diameter applied sticker shall be a silkscreened image in the design indicated, painted on a 2 millimeter transparent polyester film. The weather resistant, self-adhering film shall be rated for a minimum of 2 years of exterior vertical exposure and be mounted to the sign with pressure-sensitive, permanent acrylic adhesive. Shop cut sticker to round shape and provide pull-off backing sheet on adhesive side of design sticker for shipping. Provide applied design sticker in accordance with attached detail.
- e. Sign paint colors (numbers listed below for color identification only)
 - (1) Blue = Benjamin Moore Paints No. 826.
 - (2) White = Benjamin Moore Paints No. 873.
 - (3) Gold = Dupont No. B8014, Metallic gold.

1.8 STATION OPERATION AFFECT ON CONTRACTOR OPERATIONS

1.8.1 Interruption of Vehicular Traffic

If, during the performance of work, it becomes necessary to modify vehicular traffic patterns at any locations, notify the Contracting Officer at least 15 calendar days prior to the proposed modification date, and provide a Traffic Control Plan detailing the proposed controls to traffic movement for approval. The plan shall be in accordance with State and local regulations and the FHWA MUTCD, Part VI. Provide cones, signs, barricades, lights, and other traffic control

devices and personnel required to control traffic.

1.9 UNAUTHORIZED ACCESS

Ensure that the public and other unauthorized personnel do not have access to the area during the construction period.

PART 2 PRODUCTS

Not used.

PART 3 EXECUTION

Not used.

END OF SECTION

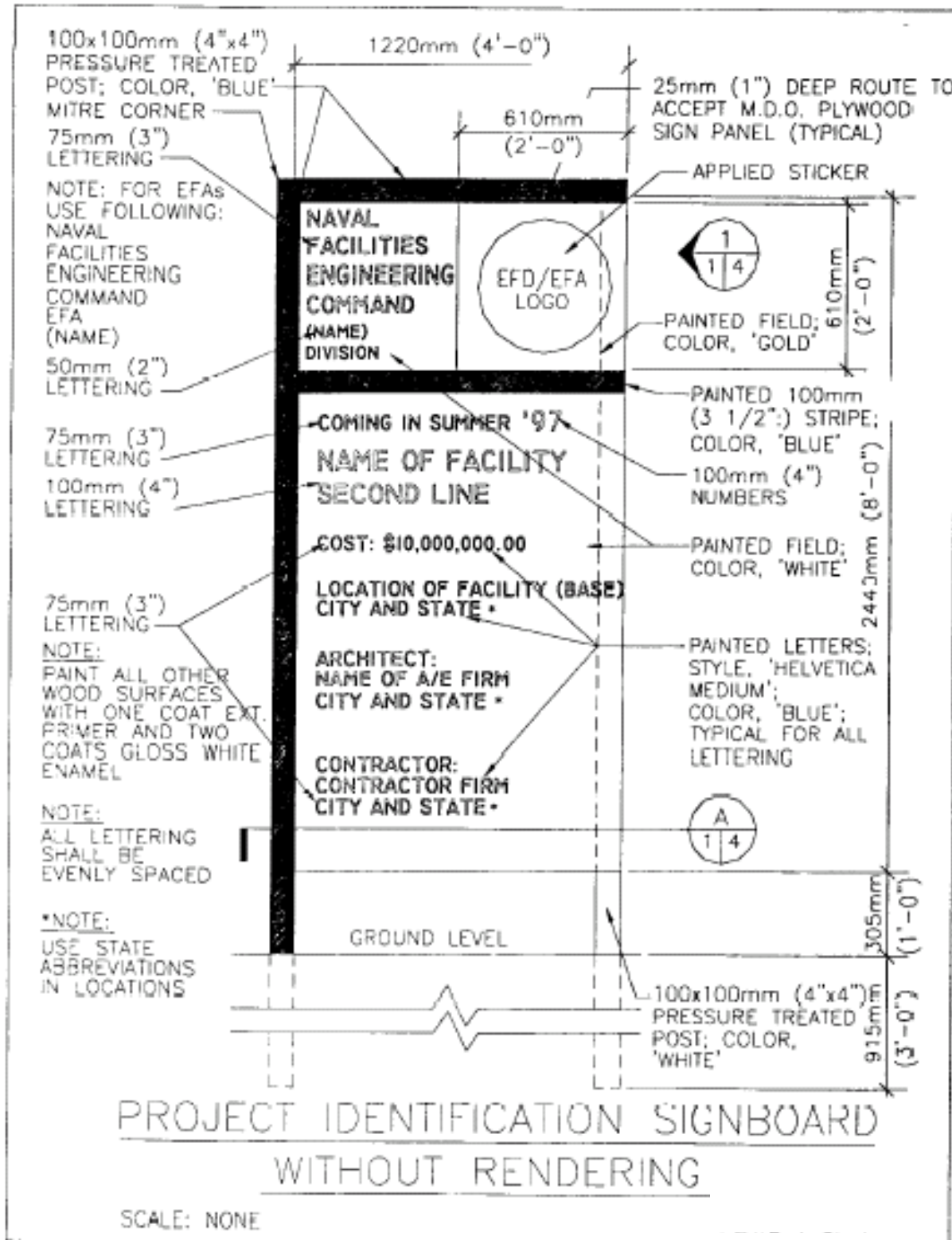

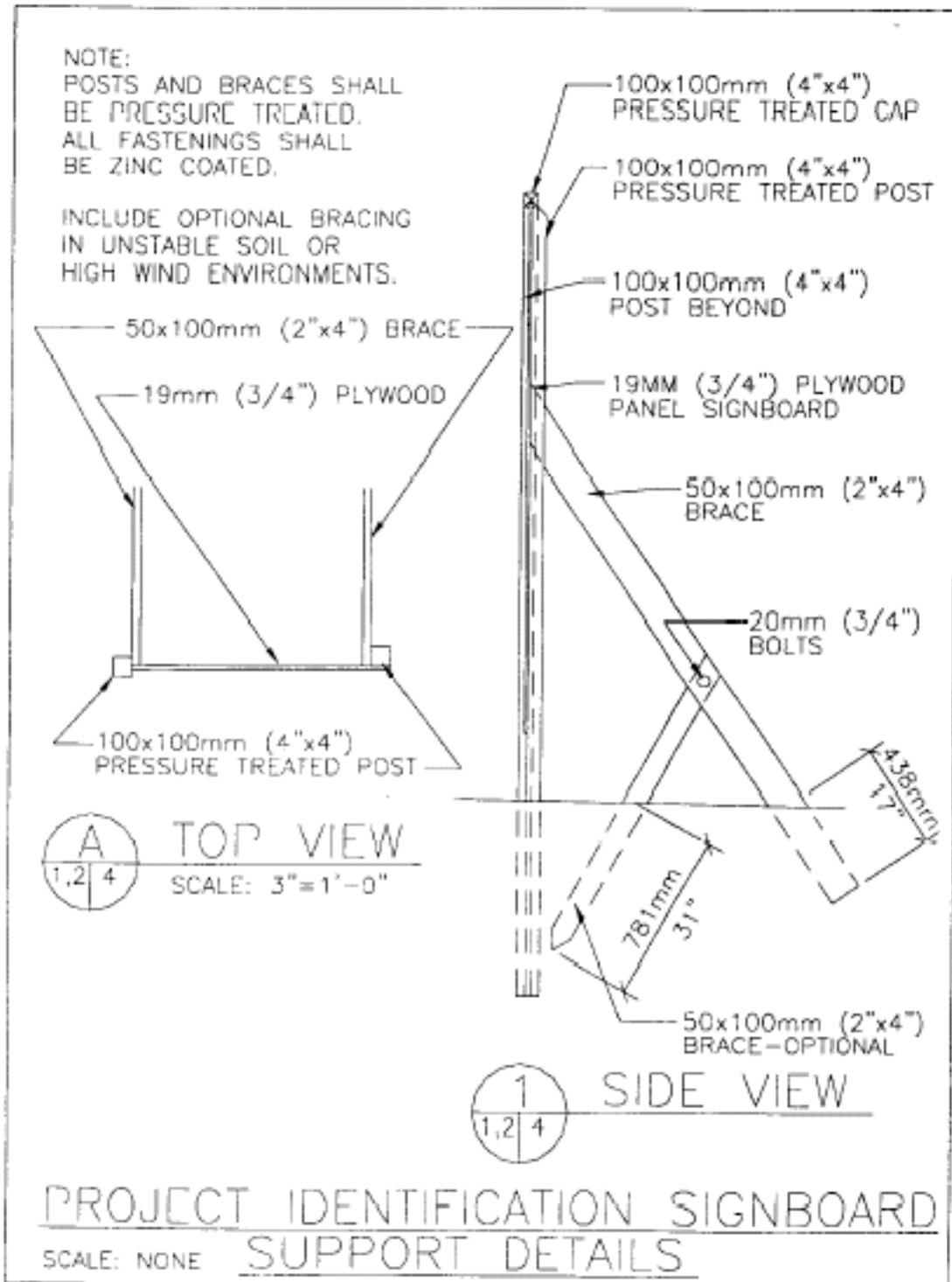

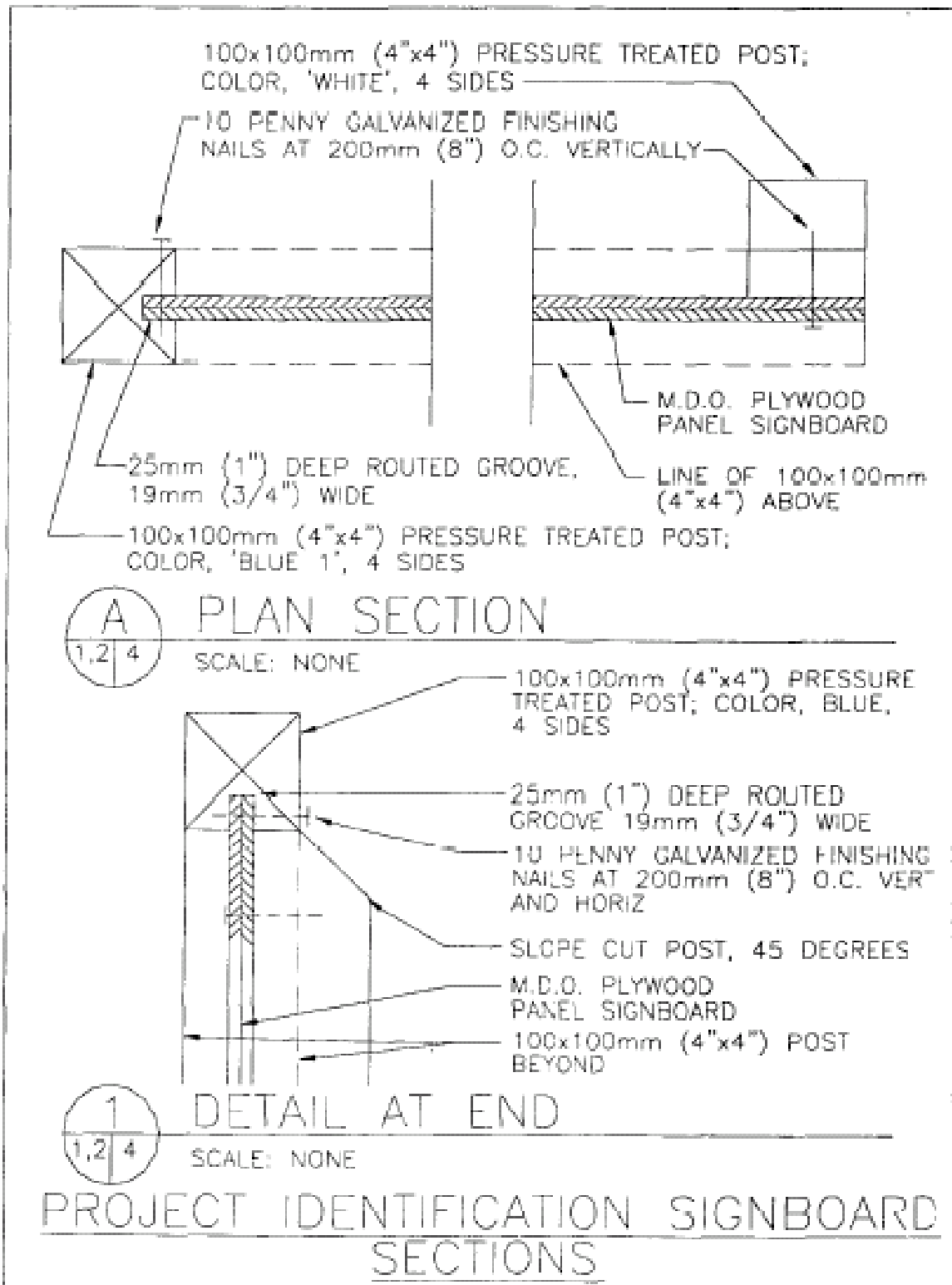

SECTION 01 57 19.00 20
TEMPORARY ENVIRONMENTAL CONTROLS

PART 1 GENERAL

1.1 REFERENCES

The publications listed below form a part of this specification to the extent referenced. The publications are referred to in the text by the basic designation only.

CODE OF FEDERAL REGULATIONS (CFR)

| | |
|-------------|--|
| 29 CFR 1910 | Occupational Safety and Health Administration Standards |
| 40 CFR 261 | Identification and Listing of Hazardous Waste |
| 40 CFR 262 | Generators of Hazardous Waste |
| 40 CFR 263 | Transporters of Hazardous Waste |
| 40 CFR 264 | Owners and Operators of Hazardous Waste Treatment, Storage, and Disposal Facilities |
| 40 CFR 265 | Interim Status Standards for Owners and Operators of Hazardous Waste Treatment, Storage, and Disposal Facilities |
| 40 CFR 300 | National Oil and Hazardous Substances Pollution Contingency Plan |
| 49 CFR 171 | General Information, Regulations, and Definitions |
| 49 CFR 172 | Hazardous Materials, Tables, and Hazardous Materials Communications Regulations |
| 49 CFR 178 | Shipping Container Specifications |

CALIFORNIA STATE WATER RESOURCES CONTROL BOARD

General Permit for Discharge of Stormwater associated with

Construction

1.2 CONTRACTOR LIABILITIES FOR ENVIRONMENTAL PROTECTION

Contractors shall complete and provide documentation of environmental training for training required by Federal, State, and local regulations.

1.3 DEFINITIONS

1.3.1 Sediment

Soil and other debris that has eroded and have been transported by runoff water or wind.

1.3.2 Solid Waste

Rubbish, debris, garbage, and other discarded solid materials, except hazardous waste as defined in Paragraph 1.3.7 Hazardous Waste, resulting from industrial, commercial, and agricultural operations and from community activities.

1.3.3 Sanitary Wastes

Wastes characterized as domestic sanitary sewage.

1.3.4 Rubbish

Combustible and noncombustible wastes such as paper, boxes, glass, crockery, metal, lumber, cans, and bones.

1.3.5 Debris

Combustible and noncombustible wastes such as ashes and waste materials resulting from construction or maintenance and repair work, leaves, and tree trimmings.

1.3.6 Garbage

Refuse and scraps resulting from preparation, cooking, dispensing, and consumption of food.

1.3.7 Hazardous Waste

Hazardous substances as defined in 40 CFR 261 or as defined by applicable State and local regulations.

1.3.8 Hazardous Materials

Hazardous materials as defined in 49 CFR 171 and listed in 49 CFR 172.

1.3.9 Oily Waste

Petroleum products and bituminous materials.

1.4 SUBMITTALS

Submit the following in accordance with Section 01 33 00 Submittal Procedures.

1.4.1 SD-01, Preconstruction Submittals

- a. Environmental Protection Plan; G
- b. Preconstruction Survey Report; G
- c. Site health and safety plan. Submit in accordance with the requirements contained in Section C, Part 3 of the Response Action Contractor (RAC) Contract (29 CFR 1910).

1.4.2 SD-07, Certificates

- a. Solid waste disposal permit/manifests; G

- b. Disposal permit/manifests for hazardous waste; G
- c. Erosion and Sediment Control Inspection Reports; G

Submit to the Contracting Officer once every 7 calendar days and within 24 hours of a storm event that produces 0.5 inch of rain or greater.

1.5 ENVIRONMENTAL PROTECTION REGULATORY REQUIREMENTS

Provide and maintain, during the life of the contract, environmental protection as defined in this Section. Plan for and provide environmental protective measures to control pollution that develops during normal construction practice. Plan for and provide environmental protective measures required to correct conditions that develop during the construction of permanent or temporary environmental features associated with the project. Comply with Federal, State, and local regulations pertaining to the environment, including but not limited to water, air, solid waste, and noise pollution.

1.6 ENVIRONMENTAL PROTECTION PLAN

1.6.1 Contents of Environmental Protection Plan

- a. Any hazardous materials (HM) planned for use on the station shall be included in the station HM Tracking Program maintained by the Safety Department. To assist this effort, the Contractor shall submit a list (including quantities) of HM to be brought to the station and copies of the corresponding Material Safety Data Sheets (MSDS). Submit this list to the Contracting Officer. At project completion, remove any hazardous material brought onto the station. Account for the quantity of HM brought to the station, the quantity used or expended during the job, and the leftover quantity that (1) may have additional useful life as a HM and shall be removed by the Contractor, or (2) may be a hazardous waste, which shall then be removed as specified herein.
- b. The Environmental Protection Plan shall list and quantify any Hazardous Waste (HW) to be generated during the project.
- c. In accordance with station regulations, store HW near the point of generation up to a total quantity of one quart of toxic waste or 55 gallons of hazardous waste. Move any volume that exceeds these quantities to a HW-permitted area within 3 days. Prior to generation of HW, contact the Contracting Officer for labeling requirements for storage of hazardous wastes.
- d. In accordance with station regulations, substitute materials as necessary to reduce the generation of HW and include a statement to that effect in the Environmental Protection Plan.
- e. Contact Contracting Officer for conditions in the area of the project that may be subject to special environmental procedures. Include this information in the Preconstruction Survey. Describe in the Environmental Protection Plan any permits required prior to working in the area, and contingency plans in case an unexpected environmental condition is discovered.
- f. Obtain permits for handling HW, and deliver completed documents to Contracting Officer for review. File the documents with the appropriate agency, and complete disposal with the approval of the Contracting Officer. Deliver correspondence with the State concerning the environmental permits and completed permits to Contracting Officer.

1.6.2 Preconstruction Site Inspection

Perform a preconstruction inspection of the project site with the Contracting Officer, and take photographs showing existing environmental conditions in and adjacent to the site.

PART 2 PRODUCTS

- 2.1 The contractor shall provide appropriate spill response materials including, but not limited to the following: containers, adsorbents, shovels, and personal protective equipment. Spill response materials shall be available at all times when contaminated or potentially contaminated materials are being handled or transported. Spill response materials shall be compatible with the type of materials and contaminants being handled.

PART 3 EXECUTION

3.1 PROTECTION OF NATURAL RESOURCES

Preserve the natural resources within the project boundaries and outside the limits of permanent work. Restore to an equivalent or improved condition upon completion of work. Confine construction activities to within the limits of the work indicated or specified.

3.1.1 Water Resources

Prevent oily or other hazardous substances from entering the ground, drainage areas, wetlands or local bodies of water. Surround all temporary fuel oil or petroleum storage tanks with a temporary earthen berm of sufficient size and strength to contain the contents of the tanks in the event of leakage or spillage.

3.1.2 Fish and Wildlife Resources

Do not unnecessarily disturb fish or wildlife. Do not alter water flows or otherwise significantly disturb the native habitat adjacent to the project, except as indicated or specified.

3.2 HISTORICAL AND ARCHAEOLOGICAL RESOURCES

Carefully protect in-place and report immediately to the Contracting Officer historical and archaeological items or human skeletal remains discovered in the course of work. Stop work in the immediate area of the discovery until directed by the Contracting Officer to resume work. The Government retains ownership and control over historical and archaeological resources.

3.3 NOISE

Make the maximum use of low-noise emission products, as certified by the U.S. Environmental Protection Agency (EPA). Blasting or use of explosives will not be permitted without written permission from the Contracting Officer, and then only during designated times.

3.4 EROSION AND SEDIMENT CONTROL MEASURES

3.4.1 Burnoff

Burnoff of the ground cover is not permitted.

3.4.2 Protection of Erodible Soils

Immediately finish earthwork brought to a final grade, as indicated or specified. Protect side and back slopes upon completion of rough grading. Plan and conduct earthwork to minimize the duration of exposure of unprotected soils.

3.4.3 Temporary Protection of Erodible Soils

Use the following methods to prevent erosion and control sedimentation:

3.4.3.1 Mechanical Retardation and Control of Runoff

Mechanically retard and control the rate of runoff from the construction site. Controls include construction of diversion ditches, benches, berms, and use of silt fences and strawbales to retard and divert runoff to protected drainage courses.

3.5 CONTROL AND DISPOSAL OF CONTRACTOR-GENERATED SOLID WASTES

Pick up solid wastes and place them in covered containers that are regularly emptied. Do not prepare or cook food on the project site. Prevent contamination of the site or other areas when handling and disposing of wastes. At project completion, leave the areas clean.

3.5.1 Disposal of Rubbish and Debris

Dispose of rubbish and debris in accordance with the requirements specified below:

3.5.1.1 Removal From Government Property

Remove and dispose of rubbish and debris from Government property.

3.5.2 Garbage Disposal

Place garbage in approved containers, and move to a pickup point or disposal area, where directed.

3.6 CONTROL AND DISPOSAL OF HAZARDOUS WASTE

3.6.1 Hazardous Waste Generation

Handle generated hazardous waste in accordance with 40 CFR 262.

3.6.2 Hazardous Waste Disposal

Dispose of hazardous waste in accordance with Federal, State, and local regulations, especially 40 CFR 263, 40 CFR 264, and 40 CFR 265. Removal of hazardous waste from Government property shall not occur without prior notification and coordination with the Contracting Officer. Transport hazardous waste by a permitted, licensed, or registered hazardous waste transporter to a treatment, storage, and disposal (TSD) facility. Hazardous waste shall be

properly identified, packaged, and labeled in accordance with 49 CFR 172. Provide completed manifests for hazardous waste disposed of off-site to the Contracting Officer within 7 days of disposal. Hazardous waste shall not be brought onto the base.

3.6.3 Hazardous Waste Storage

Store hazardous waste in containers in accordance with 49 CFR 178. Identify hazardous waste in accordance with 40 CFR 261 and 40 CFR 262. Identify hazardous waste generated within the confines of the station by the station's EPA generator identification number.

3.6.4 Spills of Oil and Hazardous Materials

Take precautions to prevent spills of oil and hazardous material. In the event of a spill, immediately notify the Contracting Officer. Spill response shall be in accordance with 40 CFR 300 and applicable State regulations.

3.6.5 Petroleum Products

Protect against spills and evaporation during fueling and lubrication of equipment and motor vehicles. Properly dispose of lubricants and excess oil.

3.7 DUST CONTROL

Control dust at all times, including during nonworking periods. Sprinkle or treat, with approved dust suppressants, the soil at the site, haul roads, and other areas disturbed by operations. Dry power brooming will not be permitted. Instead, use vacuuming, wet mopping, wet sweeping, or wet power brooming. If street sweepers are used, brooms shall not be wire.

3.8 METHANE GAS

Take precautions to avoid all ignition sources on the site during construction due to potentially explosive concentrations of methane gas.

END OF SECTION

**SECTION 02 41 00
SITE DEMOLITION**

PART 1 GENERAL

1.1 GENERAL REQUIREMENTS

Remove rubbish and debris from the project site; do not allow accumulations. Store materials that cannot be removed daily in areas specified by the Contracting Officer. Field verify topographical and survey information. Relocate and consolidate rubbish, debris, and surface soils, as indicated on the Drawings. Remove existing fencing as shown in the drawings.

All existing groundwater monitoring wells and methane monitoring probes within the site boundary are to be preserved. Refer to Section 33 24 13 MONITORING WELLS for additional information.

1.2 SUBMITTALS

1.2.1 SD-01, Preconstruction Submittal

a. Demolition Plan; G

Submit proposed demolition and removal procedures to the Contracting Officer for approval before work is started.

1.3 DUST AND DEBRIS CONTROL

Prevent the spread of dust and debris and avoid the creation of a nuisance or hazard in the surrounding area. Do not use water if it results in hazardous or objectionable conditions such as, but not limited to, ice, flooding, or pollution.

1.4 PROTECTION

Protect existing work that is to remain in place, this includes but is not limited to all groundwater monitoring wells and methane monitoring probes as shown in the drawings. Repair items that are to remain and that are damaged during performance of the work to their original condition, or replace with new. Do not overload structural elements. Provide new supports and reinforcement for existing construction weakened by demolition or removal work. Repairs, reinforcement, or structural replacement must have Contracting Officer approval.

1.5 BURNING

Burning will not be permitted.

PART 2 PRODUCTS

Not used.

PART 3 EXECUTION

3.1 REFUSE DISPOSAL

All refuse generated by construction will be controlled such that it is not carried off site by wind or water and does not constitute a hazard to worker safety or construction equipment. Refuse may be collected in construction dumpsters contracted through a local municipal waste hauler.

Remove and transport refuse in a manner that will prevent spillage on pavements, streets, or adjacent areas. Clean up spillage from pavements, streets, and adjacent areas to prevent potential damage by foreign objects.

3.2 CLEARING AND GRUBBING

The boundaries for clearing and grubbing and removal of surface waste are provided on the Drawings. Excavation of subsurface soil and wastes are also shown on the Drawings. Cleared vegetation will be disposed of off-site.

3.2.1 Organic Material (Green Waste)

Remove all trees and other woody debris that is practicable. All organic debris hauled off base shall be recycled at a local composting facility.

3.2.2 Surface Waste, Non-Organic Material

Monolithic inorganic trash or debris, such as waste concrete, pipe, abandoned equipment, or asphaltic pavement, located on the surface of the site within the boundary delineated on the Drawings may be incorporated into the waste layer if particle size does not exceed 3 inches in the largest dimension. Larger pieces may be broken down to achieve this requirement. All other pieces shall be characterized and disposed of or recycled off-base at the appropriate landfill or facility. Contractor shall minimize the generation of waste, inorganic trash, or debris whenever possible, recycle as much material as possible, and utilize the many waste recovery sites available in the area.

END OF SECTION

SECTION 02 66 00
SELECT FILL FOR COVER

PART 1 GENERAL

1.1 REFERENCES

The publications listed below form a part of this specification to the extent referenced. The publications are referred to within the text by the basic designation only.

ASTM INTERNATIONAL (ASTM)

| | |
|-------------|---|
| ASTM D 1556 | (2007) Density and Unit Weight of Soil in Place by the Sand-Cone Method |
| ASTM D 2167 | (2008) Density and Unit Weight of Soil in Place by the Rubber Balloon Method |
| ASTM D 2216 | (2005) Laboratory Determination of Water (Moisture) Content of Soil and Rock by Mass |
| ASTM D 2487 | (2006e1) Soils for Engineering Purposes (Unified Soil Classification System) |
| ASTM D 2974 | (2007a) Moisture, Ash, and Organic Matter of Peat and Other Organic Soils |
| ASTM D 422 | (1963; R 2007) Particle-Size Analysis of Soils |
| ASTM D 4318 | (2005) Liquid Limit, Plastic Limit, and Plasticity Index of Soils |
| ASTM D 4972 | (2001; R 2007) pH of Soils |
| ASTM D 6938 | (2007a) Standard Test Method for In-Place Density and Water Content of Soil and Soil-Aggregate by Nuclear Methods (Shallow Depth) |
| ASTM D 698 | (2007e1) Laboratory Compaction Characteristics of Soil Using Standard Effort (12,400 ft-lbf/cu. ft. (600 kN-m/cu. m.)) |

1.2 UNIT PRICES

Measurement and payment for "select fill" shall be based on the respective unit prices for each cubic yard of "select fill" in place. This unit price shall include the cost for development of borrow sources, cost of materials, excavation, hauling, equipment, placement, testing, and other work required to construct the "select fill" layers.

1.3 SUBMITTALS

The following shall be submitted in accordance with Section 01 33 00 SUBMITTAL PROCEDURES:

1.3.1 SD-03 Product Data

- a. Materials Handling Plan

Materials Handling Plan describing placement and compaction procedures. The plan shall also describe equipment to be used (including ground pressures).

1.3.2 SD-04 Samples

- a. Select Fill

A minimum of 50 pounds of select fill from each proposed borrow source to the Government's designated laboratory at least 15 days prior to placement.

1.3.3 SD-06 Test Reports

- a. Borrow Source Assessment; G

Borrow Source Assessment Report at least 15 days prior to select fill placement. No select fill shall be placed until the Borrow Source Assessment Report is approved. The report shall include the following: location of each borrow source; estimated quantity of borrow available; logs of subsurface explorations; and laboratory test results.

- b. Select Fill Material Tests
- c. Moisture Content and Density Tests of In-Place Select Fill

1.4 EQUIPMENT

Equipment used to place the select fill layers shall be as described in the approved Materials Handling Plan. Equipment shall not accelerate or brake suddenly, turn sharply, or be operated at speeds exceeding 5.0 miles per hour.

PART 2 PRODUCTS

2.1 SELECT FILL

Select fill shall comply with the criteria listed in the following text and shall be free of debris, frozen materials, angular rocks, roots, and organics.

REQUIRED PHYSICAL PROPERTIES OF SELECT FILL

The soil cover shall be ASTM D 2487-06e1, classification SM, SC, or ML, with a maximum liquid limit of 35 percent and a maximum plasticity index of 15 percent per ASTM D 4318-05. The maximum particle size shall be 3 inches in its largest dimension with at least 90 percent passing a ¾-inch sieve, at least 60 percent passing the No. 4 sieve, and not more than 30 percent passing a No. 200 sieve.

Refer to Section 35 31 19 COASTAL PROTECTION for fill material to be used under the revetment and below the high water elevation.

PART 3 EXECUTION

3.1 BORROW SOURCE ASSESSMENT

3.1.1 Select Fill

3.1.1.1 Classification Testing

Borrow source assessment tests shall be performed on each principal type or combination of materials proposed for use in the select fill layer to ensure compliance with specified requirements. At least one set of borrow assessment tests shall be performed on each borrow source proposed for use. A set of borrow source assessment tests shall consist of Atterberg limits (ASTM D 4318), particle size analysis (ASTM D 422), and moisture content (ASTM D 2216). Based on borrow source assessment testing, soils shall be classified in accordance with ASTM D 2487.

3.1.1.2 Moisture-Density (Compaction) Testing

A representative sample from each principal type or combination of borrow materials shall be tested to establish compaction curves using ASTM D 698. At least one compaction test shall be performed on each borrow source proposed. A minimum of 5 points shall be used to develop each compaction curve. During construction, placement of select fill shall conform to the following requirements:

- a. The minimum allowable dry density shall be no less than 90 percent of maximum dry density for the base layers and no greater than 85 percent of maximum dry density for the top one foot.
- b. The allowable moisture content range shall be +/- 3 percent of optimum.

3.1.2 Chemical Contamination Testing

Borrow used for the select fill layers shall be free of contamination. Each proposed borrow source shall be sampled and analyzed for chemical contamination.

3.2 INSTALLATION

3.2.1 Select Fill Placement

No equipment shall be operated directly on the top surface of geosynthetics without permission from the Contracting Officer. Select fill shall be pushed out over geosynthetics in an upward

tumbling motion so that wrinkles in geosynthetics do not fold over. Soil shall not be dropped directly onto geosynthetics from a height greater than 3 feet. On slopes, select fill shall be placed from the bottom of the slope upward.

3.2.1.1 Initial Lift of Select Fill Placed Over Geosynthetics

The first lift of soil placed over geosynthetics shall be a minimum of 12 inches in loose thickness. Equipment with ground pressures less than 7 psi shall be used to place and traffic compact the first lift of select fill. Traffic compaction shall consist of a minimum of 2 passes over all areas.

3.2.1.2 Subsequent Lifts of Select Fill

The loose lift thickness of each subsequent lift shall be no greater than 8 inches. Full scale placement and compaction equipment shall be allowed on areas underlain by geosynthetics after the first loose lift of soil has been placed. Compaction shall consist of a minimum of 2 passes over all areas.

3.3 CONSTRUCTION TOLERANCES

Finished surfaces shall be uniformly graded and shall be free from depressions, mounds, or windrows. The top surface of the select fill layer shall be no greater than 3 inches above the lines and grades shown on the drawings. No minus tolerance will be permitted. Rigid grade stakes shall not be driven into the select fill layer to control placement.

3.4 CONSTRUCTION TESTS

3.4.1 Select Fill Material Tests

During construction of the select fill layer, representative samples shall be taken for testing at the frequencies listed in Table 2 from the borrow source prior to placement. Test results must comply with the requirements listed in Part 2 Products or the material will be rejected for use.

TABLE 1

| SELECT FILL MATERIAL TESTING FREQUENCIES | | |
|--|-------------------|-------------|
| Test | Frequency | Method |
| Grain size analysis | 2,000 cubic yards | ASTM D 422 |
| Atterberg limits | 2,000 cubic yards | ASTM D 4318 |
| Compaction | 5,200 cubic yards | ASTM D 698 |

(Note 1)

Note 1: Compaction test results shall be compared with the results obtained during the borrow source assessment. When there are significant differences, adjustments to the acceptable moisture content or density ranges shall be proposed by the Contractor for approval.

3.4.2 Moisture Content and Density Tests of In-Place Select Fill

Moisture content and density tests shall be performed in accordance with Table 2. Density requirements will not be enforced for the first lift of the select fill layer.

TABLE 2

| MOISTURE CONTENT AND DENSITY TESTS OF IN-PLACE SELECT FILL | | |
|--|------------------------------|-------------|
| Test | Frequency | Method |
| Nuclear moisture content | 10,000 square feet | ASTM D 6938 |
| Standard moisture content | 1 for every 20 nuclear tests | ASTM D 2216 |
| Nuclear density | 10,000 square feet | ASTM D 6938 |
| Standard density | 1 for every 20 nuclear tests | ASTM D 2167 |

3.4.2.1 Test Frequencies and Locations

Each day that select fill is placed, a minimum of one set of standard moisture content and density tests shall be performed. Nuclear density and moisture content tests shall be checked at the frequencies shown in Table 3. Standard tests shall be performed at locations which are as close as possible to the locations of the nuclear tests being checked.

3.4.2.2 Nuclear Density and Moisture Content Tests

Nuclear density readings shall be taken in the direct transmission mode. When ASTM D 6938 is used, the calibration curves shall be checked and adjusted using only the sand cone method as described in ASTM D 1556. ASTM D 6938 results in a wet unit weight of soil and when using this method ASTM D 6938 shall be used to determine the moisture content of the soil. The calibration curves furnished with the moisture gauges shall also be checked along with density calibration checks as described in ASTM D 6938; the calibration checks of both the density and moisture gauges shall be made at the beginning of a job on each different type of material encountered and at intervals as directed by the Contracting Officer.

3.4.2.3 Test Results

Field moisture content and density test results shall be compared to the compaction curve for the appropriate material type being tested. If test results are not within the acceptable range for moisture content or density, as described in subparagraph Moisture-Density (Compaction) Testing, 3 additional tests shall be performed near the location of the failed parameter. If all retests pass, no additional action shall be taken. If any of the retests fail, the lift of soil shall be repaired out to the limits defined by passing tests for that parameter. The area shall then be retested as directed.

3.5 PROTECTION

3.5.1 Damage

Erosion rills or other damage that occurs shall be repaired and grades re-established. Repairs to the select fill layer shall be documented including location and volume of soil affected, corrective action taken, and results of retests.

3.5.2 Stockpiles

Storage or stockpiling of material on the completed surface of the select fill layers will not be permitted.

END OF SECTION

**SECTION 03 30 00
CONCRETE**

PART 1 GENERAL

1.1 REFERENCES

The publications listed below form a part of this specification to the extent referenced. The publications are referred to in the text by the basic designation only.

AMERICAN CONCRETE INSTITUTE (ACI)

| | |
|------------|--|
| ACI 201.2R | (2008) Durable Concrete |
| ACI 301 | (2005) Standard Specification for Structural Concrete |
| ACI 304R | (2000) Guide for Measuring, Mixing, Transporting, and Placing Concrete |
| ACI 308 | (2001) Curing Concrete |

AMERICAN SOCIETY FOR TESTING AND MATERIALS (ASTM)

| | |
|-------------|--|
| ASTM A 933 | (2007) Standard Specification for Vinyl (PVC) Coated Steel Wire and Welded Wire Fabric for Reinforcement |
| ASTM C 33 | (2008) Specification for Concrete Aggregates |
| ASTM C 94 | (2009) Specification for Ready-Mixed Concrete |
| ASTM C 143 | (2008) Test Method for Slump of Hydraulic Cement Concrete |
| ASTM C 150 | (2007) Specification for Portland Cement |
| ASTM C 1107 | (2008) Standard Specification for Packaged Dry, Hydraulic-Cement Grout (Nonshrink) |
| ASTM D 1557 | (2008) Test Method for Laboratory Compaction Characteristics of Soil Using Modified Effort (56,000 ft-lbf/ft ³) |
| ASTM D 1751 | (2008) Standard Specification for Preformed Expansion Joint Filler for Concrete Paving and Structural Construction (Nonextruding and Resilient Bituminous Types) |
| ASTM D 1752 | (2008) Standard Specification for Preformed Sponge Rubber and Cork Expansion Joint Fillers for Concrete |

Paving and Structural Construction

1.2 SUBMITTALS

Submit the following in accordance with Section 01 33 00 Submittal Procedures.

1.2.1 SD-02 Shop Drawings

a. Welded Wire Fabric; G

ACI 315. Indicate bending diagrams, assembly diagrams, splicing and laps of fabric. Do not use project Drawings as Drawings or scale project Drawings to determine the length of reinforcing fabric. Indicate the type and location of anchorage for welded wire fabric.

1.2.2 SD-05 Design Data

a. Concrete Mix Design for 4,000 pounds per square inch (psi); G

1.2.3 SD-07 Certificates

- a. Cement
- b. Aggregate
- c. Admixtures
- d. Welded Wire Fabric

1.3 CONCRETE DELIVERY, STORAGE, AND HANDLING

Do not deliver concrete until ready for concrete placement. Store concrete aggregates to prevent contamination or segregation. Store reinforcement of different sizes and shapes in separate piles or racks raised above the ground to avoid excessive rusting. Protect from contaminants such as grease, oil, and dirt. Provide for accurate identification after bundles are broken and tags removed.

PART 2 PRODUCTS

2.1 CONCRETE

2.1.1 Contractor Mix Design

ACI 301, except as modified herein. Concrete shall have a minimum of 28-day compressive strength of 3,000 psi. Slump shall be between 4 and 6 inches in accordance with ASTM C 143. Provide ASTM C 33 aggregate Size No. 57 or 67.

2.1.2 Ready-Mixed Concrete

ASTM C 94, except as modified herein. Ready-mixed concrete is defined in this specification as concrete produced regularly by a commercial establishment and delivered to the purchaser in the plastic state.

2.2 NON-SHRINKING CEMENT GROUT

ASTM C 1107.

2.3 MATERIALS

2.3.1 Cement

ASTM C 150, Type I.

2.3.2 Aggregates

ASTM C 33. Obtain aggregates for exposed concrete surfaces from one source. Aggregates shall not contain any substance that may be deleteriously reactive with the alkalis in the cement.

2.3.3 Water

Water shall be free from injurious amounts of oil, acids, alkalis, salts, organic materials, or other substances deleterious to concrete.

2.3.4 Admixtures

Provide only when approved. Calcium chloride shall not be used as an admixture.

2.3.5 Welded Wire Fabric

ASTM A 933, Class A, 6-inch by 6-inch, 10 gauge.

2.4 JOINTS

2.4.1 Expansion Joints

Expansion joint filler, premolded, shall conform to ASTM D 1751 or ASTM D 1752, 3/8 inch thick.

2.4.2 Contraction (Control) Joints

Contraction joint filler for curb and gutter shall consist of hard-pressed fiberboard.

PART 3 EXECUTION

3.1 SURFACE PREPARATION

Bring to grade and compact in 6-inch lifts to 95 percent of maximum dry density as determined by ASTM D 1557. Predampen prior to placement. Do not place concrete or shotcrete on frozen surfaces.

3.2 PLACING AGGREGATE BASE COURSE

Compact aggregate base course material in 6-inch lifts to 95 percent of maximum dry density as determined by ASTM D 1557.

3.3 PLACING REINFORCEMENT AND MISCELLANEOUS MATERIALS

Provide bars, wire fabric, and other reinforcing materials indicated or specified. In addition, provide wire ties, supports, and other devices required to install and secure the reinforcement at depths shown on the Drawings. Reinforcement shall not contain rust, scale, oil, grease, dirt, and other foreign substances that would reduce or destroy the bond. Minor rusting of uncoated reinforcement shall not be a basis of rejection, provided rusting has not reduced the effective cross sectional area of the reinforcement below the minimum diameter allowed by the applicable reinforcement standard, and that loose rust has been removed prior to placing.

3.3.1 Welded Wire Fabric

Place and secure as specified for reinforcing bars. Extend reinforcement to within 4 inches of edges.

3.3.2 Splicing

Welded wire fabric shall be overlapped 1 1/2 squares in all directions.

3.3.3 Anchorage

Anchor blocks and staples 36 inches on center maximum. Install blocks to maintain required cover over both sides of reinforcement.

3.4 FORMS

Provide as required to receive and shape shotcrete or concrete. Forms shall withstand pressures encountered during placement and maintain specified tolerances for formed surfaces. Forms shall prevent mortar leakage but permit escape of air and rebound. Construct forms to allow removal without damage to cured concrete or shotcrete. Place chamfer strips in forms to bevel salient edges and corners, except tool the top edges of walls and slabs. Chamfer 3/4 inch unless indicated otherwise. Where exposed to weather, provide nonrusting materials on formwork accessories that will contact the shotcrete.

3.4.1 Coating

Do not use mineral oil to coat forms.

3.5 MEASURING, MIXING, TRANSPORTING, AND PLACING CONCRETE

ACI 304R, except as modified herein. ASTM C 94; machine mix concrete and provide mandatory batch ticket information for each load of ready-mix concrete. Begin mixing within 30 minutes after the cement has been added to the aggregates. Place concrete within 90 minutes of either addition of mixing water to cement and aggregates or addition of cement to aggregates if the air temperature is less than 85 degrees F. Reduce mixing time to 60 minutes if the air temperature is greater than 85 degrees F. Additional water may be added, provided that both the specified maximum slump and water-cement ratio are not exceeded.

Place concrete as soon as practicable after the forms and the reinforcement have been inspected and approved. Do not place concrete when weather conditions prevent proper placement and consolidation; in uncovered areas during periods of precipitation; or in standing water prior to

placing concrete. Remove dirt, construction debris, water, snow, and ice from within forms.

3.6 CONCRETE SURFACE FINISHES

ACI 315 for repair and finish, unless otherwise specified.

3.6.1 Defects

Repair formed surfaces by removing minor honeycombs, pits greater than 1 square inch surface area or 0.25 inch maximum depth, or otherwise defective areas. Provide edges perpendicular to the surface and patch with nonshrink grout. Patch tie holes and defects when the forms are removed. Concrete with extensive honeycomb (including exposed steel reinforcement, cold joints, entrapped debris, separated aggregate, or other defects) that affects the serviceability or structural strength will be rejected, unless correction of defects is approved. Obtain approval of corrective action prior to repair. The surface of the concrete shall not vary more than the allowable tolerances of ACI 301. Exposed surfaces shall be uniform in appearance and finished to a smooth form finish, unless otherwise specified.

3.6.2 Floated Finish

All concrete work shall have a floated finish. Place, consolidate, and immediately strike off concrete to obtain proper contour, grade, and elevation before bleedwater appears. Permit concrete to attain a set sufficient for floating and supporting the weight of the finisher and equipment. If bleedwater is present prior to floating the surface, drag the excess water off or remove by absorption with porous materials.

3.7 CURING AND PROTECTION

Cure concrete in accordance with ACI 308, except as modified. Throughout curing process, maintain in moist condition and at a minimum temperature of 40 degrees F.

3.7.1 Initial Curing

Continuously moisten concrete and shotcrete for at least 24 hours after placement. Use one of the following methods:

- a. Absorptive mat or fabric, sand, or other covering kept continuously wet.
- b. Curing compound: Use only on the finish coat. Do not use on surfaces to be bonded. Double the normal application rate on natural gun finishes. When a layer of shotcrete is to be covered by a succeeding layer of shotcrete, or other cementitious finishing materials are to be bonded, remove the curing compound completely by sandblasting prior to application of additional materials.

3.7.2 Final Curing

Continue initial curing methods for the first 7 days after placing.

3.8 JOINTS

Joints shall be constructed to divide the surface into rectangular areas. Transverse contraction joints shall be spaced at 10 feet. Expansion joints shall be placed in the transverse direction instead of contraction joints every 40 feet using joint filler of the type, thickness, and width indicated. Joints surrounding structures and features within the sidewalk may consist of preformed filler material conforming to ASTM D 1752 or building paper.

3.8.1 Expansion Joints

Expansion joints shall be formed with 3/8-inch joint filler strips. Joint filler shall be placed with top edge 1/4-inch below the surface and shall be held in place with steel pins or other devices to prevent warping of the filler during floating and finishing. Immediately after finishing operations are completed, joint edges shall be rounded with an edging tool having a radius of 1/8 inch, and concrete over the joint filler shall be removed. At the end of the curing period, expansion joints shall be cleaned and filled with joint sealant. The joint opening shall be thoroughly cleaned before the sealing material is placed. Sealing material shall not be spilled on exposed surfaces of the concrete. Concrete at the joint shall be surface dry and atmospheric and concrete temperatures shall be above 50 degrees F at the time of application of joint sealing material. Excess material on exposed surfaces of the concrete shall be removed immediately and concrete surfaces cleaned.

3.8.2 Contraction (Control) Joints

The contraction joints shall be formed in the fresh concrete by cutting a groove in the top portion of the poured concrete to a depth of at least 1/8 inch using a jointer to cut the groove, or by sawing a groove in the hardened concrete with a power-driven saw, unless otherwise approved. Sawed joints shall be constructed by sawing a groove in the concrete with a 1/8 inch blade to the depth indicated. An ample supply of saw blades shall be available on the job before concrete placement is started, and at least one standby sawing unit in good working order shall be available at the jobsite at all times during the sawing operations.

3.9 FINISH EARTHWORK

After final curing is completed, backfill voids left by formwork and site preparation to match surrounding grades. Compact with pneumatic tamper.

END OF SECTION

SECTION 10 14 01
SIGNS

PART 1 GENERAL

1.1 REFERENCES

The publications listed below form a part of this specification to the extent referenced. The publications are referenced in the text by basic designation only.

AMERICAN NATIONAL STANDARD (ANS)

ANS 253.1 (1967) Fundamental Specification of Safety Colors

AMERICAN SOCIETY FOR TESTING AND MATERIALS (ASTM)

ASTM A 123 (2008) Specification for Zinc (Hot-Dipped Galvanized) Coatings on Iron and Steel Products

ASTM A 307 (2007b) Specification for Carbon Steel Bolts and Studs, 60,000 psi Tensile Strength

ASTM A 449 (2007b) Standard Specification for Hex Cap Screws, Bolts and Studs, Steel, Heat Treated, 120/105/90 ksi Minimum Tensile Strength, General Use

ASTM B 209 (2007) Specification for Aluminum and Aluminum-Alloy Sheet and Plate

1.2 SUBMITTALS

Submit the following in accordance with Section 01330 Submittal Procedures.

1.2.1 SD-02, Drawings

a. Warning sign; G

One shop drawing of sign indicated on the Drawings for approval from the Contracting Officer.

PART 2 PRODUCTS

2.1 SIGNS

2.1.1 Substrate

Conform to ASTM B 209 for aluminum sheet plate requirements. Provide caution or warning signs from aluminum plate with the thickness of at least 1.3 mm. Appropriate sign mounting hardware shall be fastened to back of substrate by rivets or welding to allow mounting of sign on post.

2.1.2 Paint

Use the opaque glossy sample colors as specified in Table 1 of Fundamental Specification of Safety Colors for Commercial Item Description, Standard Source "C" ANS 253.1-1967. Unless directed by the Contracting Officer, standard color of the background shall be yellow with black letters.

2.1.3 Posts

Signposts shall be of the U-channel type, 3 lbs/ft nominal, fabricated of hot rolled carbon steel bars. Finish shall be galvanized according to ASTM A 123. Posts shall have a uniform hole pattern.

The post shall consist of two parts, a signpost and a base post. The base post shall be identical to the signpost except having a pointed and sharpened-edge end for post driving. Holes between the base post and signpost shall be of identical pattern.

2.1.4 Anchors

Metal fasteners shall conform to ASTM A 307. All other hardware shall be Society of Automotive Engineers (SAE) Grade 5 or ASTM Grade A 449 hardness minimum. Threaded components shall use either nylon inserts or a chemical thread lock compound to prevent self-loosening. Where appropriate signs may be fastened to fencing based on approval from the Contracting Officer.

2.1.5 Signs

Provide signs around the boundary of the site according to the Drawings.

Sign shall be furnished with rounded or blunt corners and shall be free from sharp edges, burrs, splinters, or other sharp projections. The ends or heads of bolts or other fastening devices shall be located in such a way that they do not constitute a hazard.

The wording of the sign should be easy to read, concise, and as indicated on the Drawings.

PART 3 EXECUTION

3.1 SIGN INSTALLATION

Embedded metals shall be given a primer coat of the required paint on all surfaces prior to installation. Install posts to dimensions as designated on the Drawings. Do not damage coating before or during installation.

END OF SECTION

**SECTION 31 00 00
EARTHWORK**

PART 1 GENERAL

A soil cover of clean imported soil is the selected remedy to prevent contact with contaminants that may be present on the landward portion of the site. These chemicals may include metals, organic chemicals, and radionuclides. The cover components vary over the site as follows: The final cover for the radiologically impacted area at IR Sites 7 and 18 will consist of a 3 foot cover layer of clean imported soil and a demarcation layer. The final cover for the non-radiologically impacted area at IR Sites 7 and 18 will consist of a 2 foot cover of clean imported soil. Refer to SECTION 35 31 19 Revetment for specifications relating to construction of the revetment section.

1.1 REFERENCES

The publications listed below form a part of this specification to the extent referenced. The publications are referenced in the text by the basic designation only.

AMERICAN SOCIETY FOR TESTING AND MATERIALS (ASTM)

| | |
|-------------|---|
| ASTM D 1556 | (2007) Standard Test Method for Density and Unit Weight of Soil in Place by the Sand-Cone Method |
| ASTM D 1557 | (2007) Test Method for Laboratory Compaction Characteristics of Soil Using Modified Effort (56,000 ft-lbf/ft ³) |
| ASTM D 2216 | (2005) Laboratory Determination of Water (Moisture) Content of Soil and Rock by Mass |
| ASTM D 2487 | (2006) Classification of Soils for Engineering Purposes (Unified Soil Classification System) |
| ASTM D 6938 | (2008) Density of Soil and Soil-Aggregate in Place by Nuclear Methods (Shallow Depth) |
| ASTM D 4318 | (2005) Test Method for Liquid Limit, Plastic Limit, and Plasticity Index of Soils |

UNITED STATES ENVIRONMENTAL PROTECTION AGENCY (EPA)

| | |
|--------|--|
| SW 846 | (2008) Test Methods for Evaluating Solid Waste |
|--------|--|

1.2 DEFINITIONS

1.2.1 Solid Waste

Rubbish, debris, garbage, and other discarded solid non-inert materials resulting from industrial, commercial, and agricultural operations and from community activities.

1.2.2 Excavation Spoils

31 00 00-1

EARTHWORK

Excavated soil and sediment from shoreline and boundaries of the site will be placed on the site, compacted, and the soil cover constructed above the placed excavated spoils.

1.2.3 Compacted Cover

The soil cover layer is the primary cover layer and consists of imported materials to 0.5 foot from the final cover surface.

1.2.4 Erosion Resistant Layer

The upper 0.5 foot of the soil cover is the erosion resistant layer and consists of imported material and vegetative cover.

1.3 SUBMITTALS

Submit the following in accordance with Section 01 33 00 Submittal Procedures.

1.3.1 SD-01, Preconstruction Submittals

- a. Sampling and Analysis Plan; G

1.3.2 SD-03, Product Data

- a. Composite Turf Reinforcement Matting

1.3.3 SD-06, Field Test Reports

- a. Soil material tests
- b. Confirmation Screening Sampling Results; G

See Table 1 for testing frequency and type. Submit raw data as available and summarize weekly.

1.3.4 SD-07, Certificates

- a. California Registered Civil Engineer or Geologist certification

1.3.5 SD-11, Closeout Submittals

- a. Final soil cover survey with As-Built Drawings
- b. Survey information on permanent local site monuments

1.4 DELIVERY, STORAGE, AND HANDLING

Perform in a manner to prevent contamination or segregation of materials.

PART 2 PRODUCTS

2.1 COMPACTED COVER MATERIAL AND EROSION RESISTANT LAYER MATERIAL

Imported material used for foundation layer shall conform to specifications of 2.1.1 of this section. The soil shall be free of debris, roots, wood, scrap metal, vegetation, refuse, soft unsound particles, and deleterious or objectionable materials.

2.1.1 Soil Classification

The soil cover shall be ASTM D 2487-06e1, classification SM, SC, or ML, with a maximum liquid limit of 35 percent and a maximum plasticity index of 15 percent per ASTM D 4318-05. The maximum particle size shall be 3 inches in its largest dimension with at least 90 percent passing a ¾-inch sieve, at least 60 percent passing the No. 4 sieve, and not more than 30 percent passing a No. 200 sieve.

2.2 COMPOSITE TURF REINFORCED MATTING (CTRM)

The composite turf reinforcement mat (CTRM) shall be a machine-produced mat of 100 percent natural fiber matrix incorporated into a permanent three-dimensional netting structure. The matrix shall be stitch bonded between a heavy duty ultraviolet (UV) stabilized bottom net, crimped intermediate netting, and a heavy-duty, UV-stabilized top net. The crimped netting shall form prominent, closely spaced ridges across the entire width of the mat. The three nettings shall be stitched together with UV-stabilized polypropylene thread to form a permanent three-dimensional structure. Matting shall be three-dimensional geomatrix of heavy nylon monofilaments fused at their intersections. Ninety percent of the geomatrix shall be open space available for soil and root interaction with filaments. Matting shall have three-dimensional strength without laminated or stitched layers. The matting shall be a minimum weight of 8 ounces per square yard with a minimum thickness of 0.4 inches. In accordance with ASTM D 5034, the matting shall have a minimum tensile strength of 85 pounds per foot in each direction. The matting shall be for permanent service.

The permanent composite turf reinforcement mat shall have the following physical properties:

COMPOSITE STRUCTURE

| <u>Property (min)</u> | <u>Test Method</u> | <u>Typical</u> | <u>MARV*</u> |
|-----------------------|--------------------|--------------------------------------|--------------------------------------|
| Thickness | ASTM D5199 | 0.60 in | 0.58 in |
| Resiliency | ASTM D1777 | 88% | 86% |
| Density | ASTM D792 | 0.48 oz/in ³ | 0.46 oz/in ³ |
| Mass/Unit Area | ASTM D5261 | 12.00 oz/yd ² | 10 oz/yd ² |
| Porosity | ECTC Guidelines | 95.0% | 92.0% |
| Open Volume per Area | ECTC Guidelines | 800 in ³ /yd ² | 750 in ³ /yd ² |
| Stiffness | ASTM D1388 | 3.7 oz-in | 3.1 oz-in |
| Light Penetration | ECTC Guidelines | 5.0% | 4.5% |
| MD Tensile Strength | ASTM D5035 | 640 lbs/ft | 450 lbs/ft |
| MD Elongation (max) | ASTM D5035 | 14.0% | 18.0% |

31 00 00-3

| | | | |
|---|------------|------------|------------|
| TD Tensile Strength | ASTM D5035 | 890 lbs/ft | 700 lbs/ft |
| TD Elongation (max) | ASTM D5035 | 11.0% | 13.0% |
| <u>Tensile Strength at 10% Elongation</u> | | | |
| MD Tensile Strength | ASTM D5035 | 320 lbs/ft | 200 lbs/ft |
| TD Tensile Strength | ASTM D5035 | 520 lbs/ft | 420 lbs/ft |

NET STRUCTURE

| <u>Property (min)</u> | <u>Test Method</u> | <u>Typical</u> | <u>MARV*</u> |
|-----------------------|--------------------|----------------|--------------|
| Thickness | ASTM D5199 | 0.50 in | 0.42 in |
| Resiliency | ECTC Guidelines | 65% | 60% |
| UV Stability | ASTM D4355** | 80% | N/A |
| MD Tensile Strength | ASTM D5035 | 500 lbs/ft | 300 lbs/ft |
| MD Elongation (max) | ASTM D5035 | 30% | 52% |
| TD Tensile Strength | ASTM D5035 | 800 lbs/ft | 620 lbs/ft |
| TD Elongation (max) | ASTM D5035 | 15% | 17% |

*Minimum average roll values (MARV) are calculated as the typical plus or minus two standard deviations. Statistically, this calculation yields a 97.7 percent degree of confidence that any samples collected will exceed the value reported. "Typical" indicates the mean or average.

**ASTM D5035 (4 inch strip) Tensile Strength and % Strength Retention of material following 1,000 hours exposure in Xenon-Arc Weatherometer.

MD – Machine direction TD – Transverse direction

2.3 SUB GRADE

Excavation spoils for the preparation of the site from the boundary and shoreline will be reused on site to the extent possible. Refer to the drawings for placement location. Excavated material will be screened for low level radionuclide at the designated screening area and only uncontaminated soil will be used for fill as needed below the cover.

PART 3 EXECUTION

3.1 SCHEDULE

Contractor shall schedule earthwork such that seeding (see Section 32 92 19 Landscaping) occurs in the months of February, March, or April. Contractor is responsible for maintaining completed work and environmental controls (see Section 01 57 19.00 20 Temporary Environmental Controls) at all times, including gaps in construction activity.

3.2 SURFACE AND SUBGRADE PREPARATION

Grading and preparation of the surface for construction should follow the drawings.

3.2.1 Stockpile Excavated Spoils

Materials removed from excavations and intended to be reused as fill below cover later shall be stockpiled at an on-site location designated by the Contracting Officer.

3.3 PROTECTION

3.3.1 Drainage and Dewatering

Provide for the collection and disposal of surface and subsurface water encountered during construction as described in the following sections.

3.3.1.1 Drainage

Drain the site during periods of construction to keep soil materials sufficiently dry. The Contractor shall establish storm drainage features at the earliest stages of site development. Throughout construction, grade the construction area to provide positive surface water runoff away from the construction activity or provide temporary ditches, swales, and other drainage features and equipment as required to maintain dry soils. When unsuitable working platforms for equipment operation and unsuitable soil support for subsequent construction features develop, remove unsuitable material and provide new soil material as specified herein. The Contractor is responsible for assessing the conditions of soil and groundwater presented by the plans and specifications and to employ necessary measures to permit construction to proceed.

3.4 EXCAVATION

Excavate to depths and dimensions indicated on the Drawings. Reuse excavated, screened, and uncontaminated materials to the extent possible in the areas below cover. Soil disturbed or weakened by Contractor's operations and soils softened or made unsuitable for subsequent construction caused by exposure to weather shall be removed and replaced. Excavated soil shall be stockpiled when necessary in the immediate area or at an on-site location as directed by the Contracting Officer. Keep excavations free from water while construction is in progress. Notify the Contracting Officer immediately in writing if it becomes necessary to remove rock or hard, unstable, or otherwise unsatisfactory material. Blasting will not be permitted.

Excavated material from the shoreline and upland areas will be transported to the designated screening area following excavation. Material failing screening will not be used on site and will be disposed of appropriately. Compaction should follow the same provisions as for the soil covers.

3.5 MATERIAL STORAGE

Excavated material shall be placed in either temporary storage or transported directly for screening following the excavation. Storage units shall be in good condition and construction of materials that are compatible with the material to be stored. If multiple units are required for segregation, each unit shall be clearly labeled with an identification number and a written log shall be kept to track the material.

3.6 SOIL COVER

31 00 00-5

EARTHWORK

Soil cover shall be constructed to the elevations and slopes indicated on the Drawings. The soil cover, shall be compacted in 6-inch lifts to no less than 90 percent of maximum dry density at \pm 3 percent of optimum moisture content. The top one foot shall be subject to one pass with a field packer resulting in a compaction to not greater than 85 percent of maximum dry density.

3.7 GRASSED WATERWAY

Grade waterways as indicated on the Drawings. Vegetate grassed waterway as shown on the Drawings and in accordance with Section 02922 Landscaping before placing CTRM.

3.8 COMPOSITE TURF REINFORCED MATTING (CTRM)

Install matting in areas indicated on the Drawings and in accordance to manufacturer's instructions.

3.8.1 Slopes

Prepare soil before installing matting, including any necessary application of lime, fertilizer, and seed.

Begin at the top of the slope by anchoring the matting in a 6-inch deep by 6-inch wide trench with approximately 12 inches of matting extended beyond the up-slope portion of the trench. Anchor the matting with a row of staples/stakes approximately 12 inches apart in the bottom of the trench. Backfill and compact the trench after stapling. Apply seed to compacted soil and fold remaining 12-inch portion of matting back over seed and compacted soil. Secure matting over compacted soil with a row of staples/stakes spaced approximately 12 inches apart across the width of the matting.

Roll the matting down the slope. Matting will unroll with appropriate side against soil surface. All matting must be securely fastened to soil surface by placing staples/stakes in appropriate locations according to manufacturer's recommendations.

The edges of parallel matting must be stapled with approximately 2 inch to 5 inch overlap depending on manufacturer's recommendation. Consecutive matting spliced down the slope face must be placed end over end (shingle style) with an approximate 3-inch overlap. Shingle all layers of CTRM such that upgradient panels overlay downgradient panels along slope transverse. Staple through overlapped area, approximately 12 inches apart across entire matting width.

3.8.2 Grassed Channel

Prepare soil and topsoil before installing matting, including any necessary application on lime, fertilizer, and seed.

Shingle all layers of CTRM such that upgradient panels overlay downgradient panels.

Begin at the top of the channel by anchoring the matting in a 6-inch deep by 6-inch wide trench with approximately 12 inches of matting extended beyond the upslope portion of the trench.

Anchor the matting with a row of staples/stakes approximately 12 inches apart in the bottom of the trench. Backfill and compact the trench after stapling. Apply seed to compacted soil and fold remaining 12-inch portion of matting back over seed and compacted soil. Secure matting over compacted soil with a row of staples/stakes spaced approximately 12 inches apart across the width of the matting.

Roll center matting in direction of water flow in bottom of channel. Matting will unroll with appropriate side against the soil surface. All matting must be securely fastened to soil surface by placing staples/stakes in appropriate locations according to manufacturer's recommendation.

Place consecutive matting end over end (shingle style) with a 4 inch to 6 inch overlap. Use a double row of staples staggered 4 inches apart and 4 inches on center to secure matting. Full-length edge of matting at top of side slopes must be anchored with a row of staples/stakes approximately 12 inches apart in a 6- inch deep by 6- inch wide trench. Backfill and compact the trench after stapling.

Adjacent matting must be overlapped approximately 2 inches to 5 inches , depending on manufacturer's recommendations and stapled. Install staple check slots at 30 to 40 foot intervals. Use a double row of staples staggered 4 inches apart and 4 inches on center over entire width of the channel.

The terminal end of the matting must be anchored with a row of staples/stakes approximately 12 inches apart in a 6-inch deep by 6-inch wide trench. Backfill and compact the trench after stapling.

Horizontal staple spacing should be altered if necessary to allow staples to secure the critical points along the channel surface.

3.9 FINISHING OPERATIONS

3.9.1 Grading

Finish grades as indicated within plus or minus one tenth (0.1) of one foot. Grade smooth existing surfaces that are to remain but have been disturbed by the Contractor's operations. Final grading shall not take place without subsequent placement of erosion resistant seeding layer within 2 calendar days or as weather conditions dictate. Grid spacing shall be 20-foot by 20-foot or smaller for survey verification of thickness and grade.

3.9.2 Seeding

Provide as specified in Section 32 92 19 Seeding.

3.9.3 Protection of Surfaces

Protect newly graded areas from traffic, erosion (see Section 01 57 19.00 20 Temporary Environmental Controls), and settlement that may occur. Repair or re-establish damaged grades, elevations, or slopes.

3.10 DISPOSAL OF SURPLUS MATERIAL

31 00 00-7

Dispose of all surplus materials or other non-suitable material, including brush, refuse, stumps, roots, and timber into an appropriate off-site disposal facility. All organic debris hauled off base shall be recycled at a local composting facility. Contractor shall minimize the generation of waste, inorganic trash, or debris whenever possible, recycle as much material as possible, and utilize local waste recovery sites available in the area.

3.11 FIELD QUALITY CONTROL

3.11.1 Sampling

Collect the number and size of samples required to perform the specified tests of source materials.

3.11.2 Source Testing

Determine laboratory compaction characteristics and soil classification for each material used. Provide additional tests for every source change. See Table 1.

Sample all imported materials for the soil cover and topsoil layers once per source. Collect samples according to laboratory instruction. The laboratory shall analyze samples according to U.S. Environmental Protection Agency SW 846.

3.11.3 Field Density Tests

See Table 2. If a test location fails, the surrounding area shall be reworked up to at least half the distance to all nearby test locations that passed. Then, a new location within 10 feet of the previous test location shall be retested. Repeat until test location area passes.

Nuclear gauge results (ASTM D 6938-08a) shall be compared with and calibrated to oven-dried water content (ASTM D 2216-05) and sand cone (ASTM D 1556-07) tests according to the larger of the frequencies of the oven-dried water content and sand cone tests.

3.11.4 Oversight

All earthwork will be overseen by a California Registered Geologist or Civil Engineer.

3.12 FINAL COVER SURVEY

Perform a final cover survey of the cover once construction is complete. Include the final survey information on the as-built Drawings.

3.12.1 Permanent Local Site Monuments

Install two permanent monuments on the final cover and two local monuments as designated on the Drawings.

TABLE 1
SOIL COVER TESTING
REQUIREMENTS AND FREQUENCY

| Test | ASTM Method | Frequency | Required Minimum Criteria |
|-------------------------|--|--|--|
| Density & Moisture | Nuclear gauge D 6938-08a | One per 2,500 s.f. | See Table 2 |
| Density | Sand Cone D1556-07 | One per 50,000 s.f. (minimum one per day) | See Table 2 |
| Moisture | Oven D2216-05 (with cor. to Nuclear gauge D 6938-08a) | One per 50,000 s.f. (minimum one per day) | Based on compaction curves |
| Compaction Curves | Mod. Proctor D1557-07 | One per change in material | n/a |
| Identification of Soils | D 2487-06e1 | One per change in material | GW, GP, GM, SW, SP, SM (bottom 6" per manufacturer's recommendation) |

TABLE 2
SOIL COVER COMPACTION

| Fill Type | Maximum Loose Lift Thickness ¹ (in.) | Moisture Content | Lift Density | Method of Test |
|---|--|------------------|--------------|-----------------------------------|
| All material greater than 1 foot from final cover elevation | 6 | ± 3% of optimum | 90% min | ASTM D 6938-08a and ASTM D1557-07 |
| All material less than 1 foot from final cover elevation | 6 | ± 3% of optimum | 85% max | ASTM D 6938-08a and ASTM D1557-07 |

¹Thinner lifts may be required to obtain adequate compaction.

END OF SECTION

31 00 00-9

EARTHWORK

**SECTION 31 05 22
GEOTEXTILES**

PART 1 GENERAL

1.1 UNIT PRICES

1.1.1 Payment

Payment will be made at the contract unit price and will constitute full compensation to the Contractor for providing all plant, labor, material, and equipment and performing all operations necessary for the complete and satisfactory installation of the geotextile. The following items are included in the contract unit price for geotextiles and will not be counted a second time in the process of determining the extent of geotextile placed: Material and associated equipment and operation used in laps, seams, or extra length; securing pins and associated material, equipment, and operations; and material and associated equipment and operations used to provide cushioning layer of sand or gravel or both to permit increase in allowable drop height of stone. No payment will be made for geotextiles replaced because of waste, contamination, damage, repair, or due to Contractor fault or negligence.

1.1.2 Measurement

Measure the as-built surface area, covered by geotextile, in square yards. Allowance will be made for geotextile in anchor and/or drainage trenches but no allowance will be made for waste, overlaps, damaged materials, repairs, or materials used for the convenience of the Contractor.

1.1.3 Unit of Measure

Unit of measure: square feet.

1.2 REFERENCES

The publications listed below form a part of this specification to the extent referenced. The publications are referred to within the text by the basic designation only.

ASTM INTERNATIONAL (ASTM)

| | |
|-------------|---|
| ASTM D 123 | (2007) Terminology Relating to Textiles |
| ASTM D 4354 | (1999; R 2004) Sampling of Geosynthetics for Testing |
| ASTM D 4355 | (2007) Deterioration of Geotextiles from Exposure to Light, Moisture and Heat in a Xenon-Arc Type Apparatus |
| ASTM D 4491 | (1999a; R 2004e1) Water Permeability of Geotextiles by Permittivity |

31 05 22-1

GEOTEXTILES

| | |
|-------------|---|
| ASTM D 4533 | (2004) Trapezoid Tearing Strength of Geotextiles |
| ASTM D 4632 | (2008) Grab Breaking Load and Elongation of Geotextiles |
| ASTM D 4759 | (2002; R 2007) Determining the Specification Conformance of Geosynthetics |
| ASTM D 4751 | (2004) Determining Apparent Opening Size of a Geotextile |
| ASTM D 4833 | (2007) Index Puncture Resistance of Geotextiles, Geomembranes, and Related Products |
| ASTM D 4873 | (2002) Identification, Storage, and Handling of Geosynthetic Rolls and Samples |
| ASTM D 4884 | (1996; R 2003) Strength of Sewn or Thermally Bonded Seams of Geotextiles |

U.S. ARMY CORPS OF ENGINEERS (USACE)

| | |
|----------------|---|
| EM 1110-2-1601 | (1994; Change 1) Hydraulic Design of Flood Control Channels |
|----------------|---|

1.3 SUBMITTALS

Submit the following in accordance with Section 01 33 00 SUBMITTAL PROCEDURES:

1.3.1 SD-03 Product Data

a. Thread

A minimum of 7 days prior to scheduled use, proposed thread type for sewn seams along with data sheets showing the physical properties of the thread.

b. Manufacturing Quality Control Sampling and Testing

A minimum of 7 days prior to scheduled use, manufacturer's quality control manual.

1.3.2 SD-04 Samples

a. Geotextile

Geotextile samples for testing, if requested, to determine compliance with the requirements in this specification, a minimum of 60 days prior to the beginning of installation of the same textile. Upon delivery of the geotextile, submit duplicate copies of the written certificate of compliance signed by a legally authorized official of the manufacturer. The certificate shall state that the

geotextile shipped to the site meets the chemical requirements and exceeds the minimum average roll value listed in Table 1. Upon request, supply quality control and quality assurance tests for the geotextile. Provide all samples from the same production lot as will be supplied for the contract, of the full manufactured width of the geotextile by at least 10 feet long, except that samples for seam strength may be a full width sample folded over and the edges stitched for a length of at least 5 feet. Samples submitted for testing shall be identified by manufacturers lot designation. For needle punched geotextile, the manufacturer shall certify that the geotextile has been inspected using permanent on-line metal detectors and does not contain any needles.

1.3.3 SD-07 Certificates

SD-07 Certificates

a. Geotextile

Manufacturer's certification of the geotextile material. All brands of geotextile and all seams to be used will be accepted on the basis of mill certificates or affidavits. Submit duplicate copies of the mill certificate or affidavit signed by a legally authorized official from the company manufacturing the geotextile. The mill certificate or affidavit shall attest that the geotextile meets the chemical, physical and manufacturing requirements stated in this specification.

1.4 DELIVERY, STORAGE, AND HANDLING

Deliver only approved geotextile rolls to the project site. All geotextile shall be labeled, shipped, stored, and handled in accordance with ASTM D 4873. No hooks, tongs, or other sharp instruments shall be used for handling geotextile.

PART 2 PRODUCTS

2.1 MATERIALS

2.1.1 Filter Layer Geotextile

2.1.1.1 General

Provide geotextile that is a woven pervious sheet of plastic yarn as defined by ASTM D 123 matching or exceeding the minimum average roll values listed in Table 1. Strength values indicated in the table are for the weaker principal direction.

| TABLE 1: MINIMUM PHYSICAL REQUIREMENTS FOR DRAINAGE GEOTEXTILE | | | |
|--|-------------------|--------------------------------|-------------|
| PROPERTY | ACCEPTABLE VALUES | UNITS | TEST METHOD |
| GRAB STRENGTH | 250 | lb | ASTM D 4632 |
| PUNCTURE | 120 | lb | ASTM D 4833 |
| TRAPEZOID TEAR | 60 | lb | ASTM D 4533 |
| APPARENT OPENING | 70 | SIZE U.S. SIEVE | ASTM D 4751 |
| PERMITTIVITY | 0.28 | sec -1 | ASTM D 4491 |
| ULTRAVIOLET DEGRADATION | 90 | Percent at 500 Hrs ASTM D 4355 | ASTM D 4355 |

2.1.1.2 Geotextile Fiber

Fibers used in the manufacturing of the geotextile shall consist of a long-chain synthetic polymer composed of at least 85 percent by weight of polyolefins, polyesters, or polyamides. Add stabilizers and/or inhibitors to the base polymer, if necessary to make the filaments resistant to deterioration caused by ultraviolet light and heat exposure. Reclaimed or recycled fibers or polymer shall not be added to the formulation. Geotextile shall be formed into a network such that the filaments or yarns retain dimensional stability relative to each other, including the edges. Finish the edges of the geotextile to prevent the outer fiber from pulling away from the geotextile.

2.1.1.3 Securing Pins

Secure the geotextile to the embankment or foundation soil by pins to prevent movement prior to placement of revetment materials. Other appropriate means to prevent movement such as staples, sand bags, and stone could also be used. Insert securing pins through both strips of overlapped geotextile along the line passing through midpoints of the overlap. Remove securing pins as placement of revetment materials are placed to prevent tearing of geotextile or enlarging holes. Maximum spacing between securing pins depends on the steepness of the embankment slope. The maximum pins spacing shall be equal to or less than the values listed in Table 2. When windy conditions prevail at the construction site, increase the number of pins upon the demand of the Contracting Officer. Anchor terminal ends of the geotextile with key trench or apron at crest, toe of the slope and upstream and downstream limits of installation.

TABLE 2

| MAXIMUM SPACING FOR SECURING PINS | |
|-----------------------------------|--------|
| EMBANKMENT SLOPE, SPACING | |
| STEEPER THAN 1V ON 3H, | 2 feet |
| 1V ON 3H TO 1V ON 4H, | 3 feet |
| FLATTER THAN 1V ON 4H, | 5 feet |

2.1.2 DEMARCATION LAYER GEOTEXTILE

Provide demarcation layer geotextile that is a nonwoven pervious sheet of polymeric material consisting of long-chain synthetic polymers composed of at least 95 percent by weight polyolefins, polyesters, or polyamides. The use of woven slit film geotextiles (i.e. geotextiles made from yarns of a flat, tape-like character) will not be allowed. Add stabilizers and/or inhibitors to the base polymer, as needed, to make the filaments resistant to deterioration by ultraviolet light, oxidation, and heat exposure. Regrind material, which consists of edge trimmings and other scraps that have never reached the consumer, may be used to produce the geotextile. Post-consumer recycled material may also be used. Geotextile shall be formed into a network such that the filaments or yarns retain dimensional stability relative to each other, including the edges. Geotextiles shall meet the requirements specified in Table 3. Where applicable, Table 3 property values represent minimum average roll values (MARV) in the weakest principal direction. Values for AOS represent maximum average roll values.

TABLE 3

MINIMUM PHYSICAL REQUIREMENTS FOR DEMARCATION GEOTEXTILE

| PROPERTY | ACCEPTABLE VALUES | UNITS | TEST METHOD |
|-------------------------|-------------------|--------------------|---------------------------------|
| GRAB STRENGTH | 90 | LBS | ASTM D 4632 |
| TRAPEZOID TEAR | 40 | lbs | ASTM D 4533 |
| APPARENT OPENING SIZE | 60 | U.S. SIEVE | ASTM D 4751 |
| PERMITTIVITY | 2 | SEC -1 | ASTM D 4491 |
| ULTRAVIOLET DEGRADATION | 70 | PERCENT AT 500 HRS | ASTM D 4355 |
| COLORATION | BRIGHT ORANGE | | AS APPROVED BY CONTRACT OFFICER |

Detectable Marking Tape

Detectable underground marking tape consist of a maximum 5.0 Mil overall thickness, with a (0.00035") solid aluminum foil core. Construction is 0.8 Mil clear film, making the film permanently printed. The suggested print will read "CAUTION DO NOT DIG BELOW" upon approval by Contract Officer. Table 2 property values represent minimum average roll values. Refer to drawings for placement.

TABLE 4

| MINIMUM PHYSICAL REQUIREMENTS FOR DETECTABLE MARKING TAPE | | | |
|---|------------------------------------|----------|----------------|
| PROPERTY | ACCEPTABLE VALUES | UNITS | TEST METHOD |
| THICKNESS | 5 | Mil | ASTM D 2103 |
| TENSILE STRENGTH | 35 | lbs/inch | ASTM D 882 |
| ELONGATION | 80% | | ASTM D 882-75B |
| BOND STRENGTH | 5 Hours without Peel Boiling Water | | |

2.2 INSPECTIONS, VERIFICATIONS, AND TESTING

2.2.1 Manufacturing and Sampling

Geotextiles and factory seams shall meet the requirements specified in Table 1. Randomly sample geotextiles in accordance with ASTM D 4354 (Procedure Method A).

2.2.2 Site Verification and Testing

Collect samples at approved locations upon delivery to the site in accordance with ASTM D 4354 (Procedure Method B) at a frequency of once per 100,000 square feet. Test samples to verify that the geotextile meets the requirements specified in Table 1. Identify samples by manufacturers name, type of geotextile, lot number, roll number, and machine direction. Perform testing at an approved laboratory. Submit test results from the lot under review for approval prior to deployment of that lot of geotextile. Rolls which are sampled shall be immediately rewrapped in their protective covering.

PART 3 EXECUTION

3.1 SURFACE PREPERATION

Prepare surface, on which the geotextile will be placed, to a relatively smooth surface condition in accordance with the applicable portion of this specification and shall be free from obstruction, debris, depressions, erosion feature, or vegetation. Remove any irregularities so as to ensure continuous, intimate contact of the geotextile with all the surface. Any loose material, soft or low density pockets of material, shall be removed; erosion features such as rills, gullies etc. shall be graded out of the surface before geotextile placement.

3.2 INSTALLATION OF THE GEOTEXTILE

3.2.1 General

Place the geotextile in the manner and at the locations shown. At the time of installation, reject the geotextile if it has defects, rips, holes, flaws, deterioration or damage incurred during manufacture, transportation or storage.

3.2.2 Placement

Place the geotextile with the long dimension perpendicular to the shoreline and lay smooth and free of tension, stress, folds, wrinkles, or creases. Place the strips to provide a minimum width of 24 inches of overlap for each joint of the demarcation geotextile. Adjust the actual length of the geotextile used based on initial installation experience. Temporary pinning of the geotextile to help hold it in place until the filter rock layer is placed will be allowed. Remove the temporary pins as the granular material is placed to relieve high tensile stress which may occur during placement of material on the geotextile. Design protection of riprap shall be in compliance with EM 1110-2-1601. Perform trimming in such a manner that the geotextile is not damaged in any way.

Geotextile should be secured within the revetment rock at both the crest and the toe of the structure as shown in the drawings. Not less than 5 feet of additional material should be per anchoring location. Anchoring method should be approved by the Contracting Officer.

3.3 PROTECTION

Protect the geotextile at all times during construction from contamination by surface runoff; remove any geotextile so contaminated and replaced with uncontaminated geotextile. Replace any geotextile damaged during its installation or during placement of bedding materials or riprap at no cost to the Government. Schedule the work so that the covering of the geotextile with a layer of the specified material is accomplished within 7 calendar days after placement of the geotextile. Failure to comply shall require replacement of geotextile. Protect the geotextile from damage prior to and during the placement of riprap or other materials. Before placement of riprap or other materials, demonstrate that the placement technique will not cause damage to the geotextile. In no case shall any type of equipment be allowed on the unprotected geotextile.

3.4 PLACEMENT OF FILTER ROCK MATERIAL

Perform placing of filter material in a manner to ensure intimate contact of the geotextile with the prepared surface. The placement shall also be performed in a manner that will not damage the geotextile including tear, puncture, or abrasion. On sloping surfaces place the filter material from the bottom of the slopes upward. During placement, the height of the drop of riprap material shall not be greater than 12 inches or as specified in Section 35 31 19 REVETMENT. Uncover any geotextile damaged beneath the filter material, as necessary, and replaced at no cost to the Government.

Refer to Section 35 31 19 REVETMENT for additional information concerning the filter rock and its placement.

END OF SECTION

**SECTION 32 31 26
FENCING AND GATES**

PART 1 GENERAL

1.1 REFERENCES

The publications listed below form a part of this specification to the extent referenced. The publications are referenced in the text by basic designation only.

FEDERAL SPECIFICATIONS (FS)

| | |
|----------------|---|
| FS RR-F-191 | (Rev. J) Fencing, Wire and Post Metal (and Gates, Chain-Link Fence Fabric, and Accessories) (General Specification) |
| FS RR-F-191/1D | (Rev. C) Fencing, Wire and Post, Metal (Chain-Link Fence Fabric) (Detail Specification) |
| FS RR-F-191/2D | (Rev. C) Fencing, Wire and Post, metal (Chain-Link Fence Gates) (Detail Specification) |
| FS RR-F-191/3D | (Rev. C) Fencing, Wire and Post, Metal (Chain-Link Fence Posts, Top Rails and Braces) (Detail Specification) |
| FS RR-F-191/4D | (Rev. C) Fencing, Wire and Post, Metal (Chain-Link Fence Accessories) (Detail Specification) |

1.2 DESCRIPTION

This section covers the requirements for both temporary and permanent chain link fencing for the site. Further details on the placement of the fencing and the construction details are shown the drawings. Existing fence should be used in the temporary fencing of the site to the extent practical where it will not be obstructive to the work area. Reuse temporary fence materials where practical for the construction of the final fence.

1.3 RELATED SECTIONS

Section 31 00 00 General Earthwork.

1.4 SUBMITTALS

The following shall be submitted in accordance with Section 01 33 00 Submittal Procedures.

1.4.1 SD-03, Manufacturer's Catalog Data

- a. Fencing components
- b. Accessories

1.5 DELIVERY, STORAGE, AND HANDLING

Deliver materials to site in an undamaged condition. Store materials off the ground to provide protection against oxidation caused by ground contact.

PART 2 PRODUCTS

2.1 Gates

FS RR-F-191/2; Type I, single swing or Type II, double swing, as indicated on the drawings. Gate dimensions shall be as indicated on the drawings. Framing and bracing members, round or square of steel alloy. PVC-coated over zinc- or aluminum-coated steel. Use minimum sizes for gate frames and braces listed in FS RR-F-191/3D for each Class and Grade. Coating for steel latches, stops, hinges, keepers, and accessories, PVC-coated over zinc- or aluminum-coated steel. Gate latches, fork type. For double swing gate, drive 1-foot of 3/4-inch nominal diameter galvanized water pipe flush to ground surface to receive vertical slider. Attach gate fabric to gate frame in accordance with manufacturer's standards, except that welding will not be permitted.

Arrange padlocking latches to be accessible from both sides of gate, regardless of latching arrangement. Padlocks shall have case-hardened shackles with bodies of a nonferrous alloy. Ten padlock keys shall be provided for each padlock, sequentially numbered and reading "DO NOT DUPLICATE."

2.1.3 Posts and Braces

FS RR-F-191/3D line posts; Class 1, steel pipe, Grade A or B. End, corner, and pull posts; Class 1, steel pipe, Grade A or B. Braces and rails; Class 1, steel pipe, Grade A or B, in minimum sizes listed in FS RR-F-191/3 for each class and grade. Provide PVC color coating, minimum thickness, 0.10 inch.

2.1.4 Fencing Accessories

Shall conform to the requirements of FS RR-F-191/4D. Provide wire ties constructed of the same material as the fencing fabric. Provide accessories with polyvinyl (PVC) coatings similar to that specified for chain-link fabric or framework.

2.1.5 Concrete

Shall conform to the requirements of Section 03 30 00 Cast-in-Place Concrete.

PART 3 EXECUTION

3.1 SITE PREPARATION

3.1.1 Excavation

Excavate to dimensions indicated for concrete-embedded items as shown on the drawings. Follow excavation procedures as specified in Section 31 00 00 Earthwork.

3.2 FENCE INSTALLATION

Consult Contracting Officer before construction of fence to determine which fences to install.

Install fence to line as indicated on the drawings, a four-sided square enclosure. Install fence in accordance with fence manufacturer's written installation instructions except as modified herein.

3.2.1 Post Setting

Set post plumb. Provide concrete bases of dimensions as indicated on the drawings. Compact concrete to eliminate voids and finish to a dome shape. Allow concrete to cure a minimum of 72 hours before performing other work on posts.

3.2.2 Bracing

Brace gate with a diagonal truss rod and truss tightener used as a tension member.

3.2.3 Fabric

Pull fabric taught and secure fabric to tension wire and posts. Secure fabric to posts using stretcher bars, ties, or clips spaced 15 inches on center, or by integrally weaving to integral fastening loops of end, corner, pull, and gate posts for full length of each post.

Install fabric on opposite side of posts from area being secured. Install fabric so that bottom of fabric is minimum 2 inches above ground level.

3.3 FENCE ACCESSORIES INSTALLATION

3.3.1 Post Caps

Install post caps as recommended by the manufacturer.

3.3.2 Gates

Install gates on side of enclosure that allows gate to swing open at least 135 degrees in a direction away from gas vent. Provide Contracting Officer with padlocks and keys.

3.4 CLEANUP

Remove waste fencing materials and other debris from the site.

END OF SECTION

**SECTION 32 92 19
SEEDING**

Part 1 GENERAL

1.1 SCOPE OF WORK

Provide all materials, labor and equipment necessary to complete all work as shown on the drawings and as specified herein, including, but not limited to, the following:

1. Apply specified treatments to all cuts and fill slopes, soil stockpiles, all disturbed areas and other areas as specified on the plans.
2. Install all temporary erosion control devices as per specification.
3. All other labor and materials reasonably incidental to the satisfactory completion of the work, including clean up of the site.

1.2 SITE CONDITIONS

It is the responsibility of the contractor to visit the site to determine existing conditions; including access to the site, the nature and extent of existing improvements upon adjacent public and private property, the nature of materials to be encountered, and other factors that may affect the work of this section. It is the responsibility of the owner to have finished the seasonal grading of the slopes; including track walking the areas to be treated with erosion control treatments.

1.3 SUBMITTALS

The following shall be submitted in accordance with Section 01 33 00 SUBMITTAL PROCEDURES:

1.3.1 SD-01 Preconstruction Submittal

- a. Vegetation Establishment Plan

1.3.2 SD-03 Product Data

- a. Seed Mixes (or individual items)
- b. Mulches
- c. Binders/Tackifiers
- d. Fertilizer
- e. Straw (Weight receipts from scales shall be required)

1.3.3 SD-06 Test Reports

- a. Soil composition tests (reports and recommendations).

1.3.4 SD-07 Certificates

- a. State certification and approval for seed

1.4 WORK SCHEDULE

The work shall progress as soon as the site becomes available consistent with normal seasonal limitations. The optimal seeding periods are between August 15th and October 15th or between January 15th and February 15th.

1.5 PRODUCT DELIVERY, STORAGE, AND HANDLING

1. All products shall be delivered to the site in manufacturer's unopened standard containers bearing original labels showing quantity, analysis and name of manufacturer.
2. All materials shall be stored in designated areas and in such a manner as to protect them from weather or other conditions that might damage or impair the effectiveness of the product.

1.6 ANALYSIS OF SAMPLES AND TESTS

1. Samples: The owner reserves the right to take and analyze samples of materials for conformity to the specifications at any time. On request, seed shall delivered to owner 30 days prior to seeding so seed can be tested. Seed samples shall be drawn in accordance with procedures outlined in AOSA, Association of Official Seed Analysts.
Rejected material: Rejected materials shall be removed immediately from the site at Contractor's expense. Contractor shall pay the cost of testing replacement materials.

1.7 FINAL ACCEPTANCE AND WARRANTY PERIOD

Upon completion of each 25% of the specified work, the owner shall accept each area. The contractor shall not provide warranty beyond those granted by any of the material manufacturers. It shall be the right of the owner to inspect work for compliance to the specifications and advise the contractor, in writing, of any work that is found to deviate from specifications.

Part 2 PRODUCTS

2.1 GENERAL

All products shall be in conformance with the specifications listed below. Any changes to products to be used shall be approved, in writing, by the owner or owner's representative prior to job site delivery.

2.2 SEED MIX

1. Composition: Seed Mixture by Weight

| 45 Total Pounds/Acre | | | |
|-----------------------------|--------------------------------------|-------------------------|--------------------|
| Pounds/Acre | Species | Common Name | % by Weight |
| 25 | Bromus carinatus | California Brome | 55.6% |
| 10 | Hordeum brachyantherum | Meadow Barley | 22.2% |
| 6 | Vulpia microstachys | Small Fescue | 13.3% |
| 4 | Trifolium wildenovii or obtusiflorum | Tomcat or Clammy Clover | 8.9% |

Proportion seed mixtures by weight.

Quality:

All seed shall be in conformance with the California State Seed Law of the Department of Agriculture. Each seed bag shall be delivered to the site sealed and clearly marked as to species, purity, percent germination, dealer's guarantee, and dates of test. In addition, the container shall be labeled to clearly reflect the amount of Pure Live Seed (PLS) contained. Prior to seeding at the request of the owner, the contractor shall provide a letter of certification, original Association of Official Seed Analysts (AOSA) seed test results, and calculations of PLS content.

2.3 MULCH

100% wood hydroseed mulch shall be composed of wood fiber derived from whole wood chips with no growth or germination inhibiting substances, and shall be manufactured in such a manner that when thoroughly mixed with seed, fertilizer, organic stabilizer, and water, in the proportions specified, will form a homogeneous slurry which is capable of being sprayed to form a porous mat. The fibrous mulch in its air-dry state shall contain not more than 15% by weight of water. The fiber shall have a temporary green dye and shall be accompanied by a certificate of compliance stating that the fiber conforms to these specifications.

2.4 ORGANIC STABILIZER/TACKIFIER

Shall be an organic substance supplied in powder form and shall be psilium-based and packed in clearly marked bags stating the contents of each package. The California Department of Food and Agriculture shall certify the material as an Auxiliary Soil Chemical.

2.5 FERTILIZER

Fertilizer shall be of commercial quality, conform to the requirements of the California Food and Agriculture Code, shall have a guaranteed analysis for nitrogen, phosphorus and potassium of 6-24-24.

2.6 STRAW

Straw shall be derived from irrigated wheat or barley fields or from rice straw. The contractor shall furnish evidence that clearance has been obtained from the County Agricultural

Commissioner, as required by law, before straw from outside the county in which it is to be used is delivered to the site of the work. Straw that has been used for bedding is prohibited.

2.7 EQUIPMENT

Hydroseeding: Equipment used for application of slurry shall be a commercial-type Hydro-Seeder and have a built-in agitation system with an operation capacity sufficient to agitate, suspend and homogeneously mix slurry. Tank capacity shall be a minimum of 1,500 gallons and shall be mounted on a truck to allow access to the site.

Distributes: Large enough to prevent stoppage and allow for even distribution of slurry over the site.

1. Pump: Shall be able to generate 150 psi at the nozzle.
2. Straw blowers: Equipment shall be specifically designed and manufactured for the application of straw. Equipment shall be of sufficient horsepower to break up and distribute straw at the specified application rate.

Part 3 EXECUTION

3.1 GENERAL

1. Areas to receive erosion control treatments include all graded areas as shown on the site plan, and other areas as determined by the owner.
2. Perform erosion control treatments on a section by section basis. On approval of the owner, and as soon as possible after grading, complete treatments in the following order of priority: stream zones, graded slopes, non-trafficked road and parking areas, building pads and other flat areas.
3. Contractor shall be available to re-treat areas disturbed by on going activities.

3.2 SOIL PREPARATION

Verification: Verify that all areas to receive erosion control treatments are free of vegetation, and other objectionable material.

Verify that grades are final for permanently treated areas and within reasonable standard for temporary treatments.

All sloped areas will be uniformly compacted.

3. No soil amendments shall be required except as noted on site plan.

3.3 HYDROSEEDING AREA

A. Preparation: Do all slurry preparation at the job site:

1. Water, mulch, fertilizer, compost, binder and other ingredients shall be added to the tank simultaneously so that the finished load is a homogenous mix of the specified ingredients.
2. Seed shall be added last and shall be discharged within 2 hours. Loads held over 2 hours will be recharged with ½ the seed rate before application.
3. Once fully loaded, the complete slurry shall be agitated for 3-5 minutes to allow for uniform mixing.

B. Application:

1. General: Apply specified slurry in a sweeping motion to form a uniform application and form a mat.

Step 1: With hydroseeder apply

| Lbs per acre - | Material |
|----------------|------------------------|
| 45 lbs | Seed Mix |
| 500 | 100 % Wood fiber mulch |
| 500 | 6-24-24 fertilizer |

Step 2 : With Starw blower apply

| | |
|------|-------|
| 4000 | Straw |
|------|-------|

Step 3: With Hydroseeder

| | |
|-----|-----------------------------------|
| 500 | 100% Wood Fiber Mulch |
| 150 | Organic Binder (such as M-binder) |

Under suitable conditions straw shall be uniformly spread at the specified rates. The straw may be pneumatically applied as long as the resulting straw is predominately 3 to 6 inches in length. The straw shall be treated with mulch and Tackifier before it can blow off the site but in no case shall straw be left untreated for more than 24 hours. The contractor will clean up areas of straw, which are blown from the site, and the areas shall be retreated at no additional expense to the owner.

2. Protection: Contractor is to stay off treated areas.
3. Unused Loads: If mixture remains in tank for more than 8 hours it shall be removed from the job site at contractor's expense.
4. Reseeding: After "Final Acceptance", reseeding will be done at the request of the owner and shall be considered extra.

3.4 CLEAN-UP

1. General: Erosion control work areas shall be maintained in a neat and orderly condition. Keep paved area free of soil.
2. Overspray: Installing contractor is responsible for washing or otherwise cleaning excess material off all area not intended to receive treatment.
3. Debris: Clean up and remove erosion control associated materials and debris from project site before Final Acceptance.

END OF SECTION

**SECTION 33 24 13
MONITORING WELLS**

PART 1 GENERAL

1.1 REFERENCES

The publications listed below form a part of this specification to the extent referenced. The publications are referenced in the text by the basic designation only.

AMERICAN SOCIETY FOR TESTING AND MATERIALS (ASTM)

| | |
|------------|--|
| ASTM C 136 | (2006) Standard Test Method for Sieve Analysis of Fine and Coarse Aggregates |
| ASTM C 150 | (2007) Standard Specification for Portland Cement |
| ASTM F 480 | (2006b) Standard Specification for Thermoplastic Well Casing Pipe and Couplings Made in Standard Dimension Ratios (SDR), SCH 40 and SCH 80 |

1.2 SUBMITTALS

Submit the following in accordance with Section 01330 Submittal Procedures.

1.2.1 SD-03, Product Data

- a. Casing
- b. Cement
- c. Protective Cover

1.2.2 SD-11, Closeout Submittal

Provide a survey report with the following data for each well:

- a. Horizontal location (northing and easting)
- b. Top of casing (TOC) elevation
- c. Adjacent ground elevation

1.3 FIELD QUALITY CONTROL

The Contractor shall provide a field geologist to inspect all material and equipment to be used in extending the monitoring wells.

The Contractor's field geologist may request minor modifications to the well construction as necessary. The need for any major modifications shall be negotiated with the Contracting Officer and the Contractor.

The Contractor shall provide at least 14 calendar days notice to the Project Engineer before any

well construction commences.

1.4 WELL CONSTRUCTION PERMITS

Well extension modification does not require construction permits. Methods should be approved by the Contracting Officer.

1.5 DELIVERY, STORAGE, AND HANDLING

The contractor shall deliver materials in an undamaged condition. All well materials shall be stored and maintained in a clean, uncontaminated condition throughout the course of the project.

PART 2 PRODUCTS

Provide all first-quality new materials, free from any defects and suitable for the intended use. Provide materials and equipment that are products of manufacturers regularly engaged in the production of such materials and equipment. Furnish and install all incidental items not specifically shown or specified that are required by good practice to provide the complete systems specified herein.

2.1 WELL CASING

Extend well casings with schedule 40 polyvinyl chloride (PVC), dimensions and lengths as indicated on drawings and manufactured to meet the requirements of ASTM F 480. Monitoring well and methane probe caps shall be completed similar to existing conditions.

2.2 BENTONITE SEAL

Pelletized or chipped sodium montmorillonite.

2.3 CEMENT

Type I or II Portland cement manufactured to meet the requirements of ASTM C 150.

2.4 CONCRETE

A 3,000 pound per square inch (psi) concrete mix. Maximum aggregate size $\frac{3}{4}$ -inch. Cement in mix shall be Type I, II, or III Portland cement according to ASTM C 150.

2.5 PROTECTIVE COVER

Provide steel or aluminum lockable protective cover set over the well casing. Paint the casing with a weather-resistant, beige paint.

Provide weather-resistant keyed alike padlocks with minimum shackle clearance of 2 inches vertical and $\frac{3}{4}$ inch horizontal.

PART 3 EXECUTION

3.1 GROUNDWATER MONITORING WELL AND METHANE PROBE EXTENSIONS

All existing groundwater monitoring wells and methane probes at the site are to be extended to meet the final elevation of the soil cover using like materials and construction as the existing wells and probes. Refer to the drawings for final elevations and construction details. Provisions for protection of the wells and probes will be necessary during construction of the soil cover.

During construction care should be taken to prevent contamination of the interior of the well from any solvents or other chemicals being used. This could be accomplished through use of well plugs or other materials.

3.6 FINISHING WELL HEAD

Finish wellhead as shown on the drawings. Cover concrete apron with topsoil and compact with pneumatic tamper. Place three non-erodible rocks, 3 feet diameter minimum, equidistantly around wellhead.

3.7 SURVEYING

Provide a California-licensed surveyor to survey horizontal and vertical coordinates for location (northing and easting), the top of casing (TOC) elevation, and adjacent ground surface elevation for each well constructed.

All northing and easting coordinates shall be based on control points shown on the drawings. Horizontal coordinates shall be measured within 0.1-foot accuracy.

All elevation measurements shall be based upon the elevation of the monuments established on site during construction shown on the drawings. All elevation measurements shall be measured within 0.01-foot accuracy. The TOC elevation shall be measured by placing the surveying rod directly on top of the north side of the well casing. The TOC elevation measuring point shall be marked with a 1/8-inch deep sawcut.

END OF SECTION

**SECTION 35 31 19
COASTAL PROTECTION**

PART 1 GENERAL

1.1 Riprap

1.1.1 Payment

Payment for riprap satisfactorily placed will be made at the applicable contract unit price for specified riprap or other suitable material. Price(s) and payment(s) shall constitute full compensation for furnishing, hauling, handling, placing, and maintaining the riprap until final acceptance by the Government. No separate payment will be made for the stockpiling of riprap, and all cost in connection with stockpiling shall be included in the contract unit price for riprap.

1.1.2 Measurement

Riprap will be measured for payment by the ton as determined by barge displacement, where direct placement into structure(s) is practicable, or by weighing by the truckload on approved scales meeting the requirements of paragraph TRUCKLOAD.

a. Truckload. Each truck load will be weighed to the nearest 0.1 ton and the final quantity rounded to the nearest whole ton. Riprap will be measured for payment by weighing on approved scales before being placed in the work. Scales shall be of sufficient length to permit simultaneous weighing of all axle loads and shall have an accuracy within 0.2 percent throughout the range of the scales. The scale's accuracy shall conform to the applicable requirements of NIST HB 44 and shall be certified by an acceptable scales company representative or by an inspector of the State Inspection Bureau charged with scales inspection within the state in which the project is located prior to weighing any riprap. The scales shall be located at the site of work. The scales shall be capable of printing a weight ticket including time, date, truck number, and weight. If commercial scales are readily available in close proximity (within 10 miles) of site of work, documentation shall be submitted certifying that the scales meet the requirements of the specification. Furnish the scales and weigh the riprap in the presence of the Contracting Officer, who will read and record the weights thereof and who will certify the correctness thereof. The Contracting Officer may elect to accept certified weight certificates furnished by a public weighmaster in lieu of scale weights at the jobsite. Quarry weights will not be accepted. Scales will be checked and certified before hauling riprap.

b. Barge Load

(1) If delivered by barge, riprap will be measured for payment by the Contracting Officer by weight determined by barge displacement. Furnish the Contracting Officer a barge displacement table not less than 10 work days prior to unloading the riprap from any barge. Each table submitted shall show the name and/or number of the barge owner, the name of the fabricator, and the certification and date of certification of the person or firm preparing the table. Furnish with the barge displacement tables a drawing or sketch of each barge, dimensioned in sufficient detail to permit checking of the tables. The drawings shall show, as a minimum, the length, width, depth of the barge, and dimensions of the rake or rakes. Each such table shall have its accuracy certified by a person or firm, other than the Contractor, customarily performing this service. Each table

submitted shall contain, in parallel columns, the freeboard of the barge in feet and tenths from zero to the full depth of the barge and the corresponding gross displacement to the nearest ton.

Each barge shall be suitably marked with at least two displacement gaging locations on each side near each end of the barge and at least two amidships on opposite sides. Each gaging location shall be marked by a line perpendicular to the edge of the barge, 4 inches wide and 1 foot long, on both the deck and side of the barge and two amid ship on opposite sides. Barges with rakes shall have the displacement gaging lines placed at each corner of the box section between the rakes. If a barge has a box end or ends, the gaging locations shall be placed approximately 4 feet from the box end(s). The freeboard will be measured at the four gaging locations and the displacement determined by the use of "STANDARD BARGE TABLES" from the average of these measurements. The displacement will be determined before and after being unloaded and the difference between these values shall be the quantity delivered. Submit the Gaging Table Data as specified in the Submittals paragraph. Barges shall be loaded so that the readings taken at the gaging locations do not vary more than 1.5 feet port to starboard fore and aft and do not vary more than 0.5 feet port to starboard. If such is not the case, trim the carrier by shifting the stone until this limit is reached, before the measurement will be accepted. The draft shall be determined from the average of all six readings weighting the readings of the middle gage at double those of the end gages. $(G1 + G2 + 2xG3 + 2xG4 + G5 + G6)$ divided by 8 = average draft.

All carriers used in transporting stone shall be free of leaks such as would render accurate gauging difficult. Facilities for inspecting the hold of each carrier to determine whether leakage is occurring shall be provided. Each carrier shall also be provided with adequate pumping facilities, and if water is found to be accumulating in the hold, the carrier shall be pumped dry before each gaging, both before and after unloading. Lightening by pumping or by transfer of crew or supplies will not be permitted while stone is being transferred. Rejected riprap and unacceptable material shall be left aboard the barge until after the final readings have been taken.

(2) Barge vessel tables are to be furnished based the water conditions and salinity specific to the site. The Contractor has the option of obtaining water samples and determining densities or unit weights of these samples. These water samples shall be taken in accordance with ASTM D 3370 (Practice A - Grab Samples) at depths of 4 and 8 feet in the area where measurements are made. Water sampling shall be performed when the barges are measured for quantities, both when fully loaded and when empty. Take water samples, as witnessed by the Contracting Officer, with the use of "Polypro" 2000 ml water sampler, or equal. Densities shall be determined as specified in ASTM D 1429 (Method D-Hydrometer Method). Testing shall be done for the Contractor by a certified testing laboratory, and test results certified by the laboratory. After review and approval of the test results by the Contracting Officer, the average of the densities obtained at 4 and 8 feet will be used as the suitable salt water conversion factor. In all calculations, the unit weight of 62.4 pounds per cubic foot will be used for fresh water.

c. Stockpiled Riprap. If the Contractor elects to stockpile riprap on the worksite or offsite, the riprap shall be weighed immediately before placement by either method described above. Riprap placed in temporary storage on the worksite as specified in paragraph WORKSITE STOCKPILE will not be required to be re-weighed prior to placement. If the barge displacement method is elected, a minimum of one-third the total maximum displacement of the barge of riprap is required on each barge.

(1) Determination of Excess Stone. All stone outside the limits and tolerances of the cross sections of the structure, except variations so minor as not to be measurable, will be deducted from the quantity of new stone for which payment is to be made. Weight of excess stone will be determined from the cross sections obtained by the method provided for in paragraph FINAL SURVEYS, on the basis that the cubic feet of volume (including voids) for each type of stone, as listed in the Table in paragraph FACTORS USED FOR CONVERTING IN PLACE VOLUME TO WEIGHT, is equal to one ton or 2,000 pounds for the bulk specific gravity and percentage of voids shown. If the bulk specific gravity of the stone furnished or the percentage of voids is other than as listed below, the cubic feet of volume equaling 2,000 pounds shall be recomputed as described in paragraph REVISIONS OF BIDDING SCHEDULE QUANTITIES. Should any excess stone be disclosed above the tolerance line as defined in paragraph TOLERANCES, its volume will be computed by the average end area method, based upon the cross section in the following manner. The average end area of excess stone above the tolerance line for two (2) successive cross sections, multiplied by the distance between the cross sections will be accepted as the volume. The Contractor will not be required to remove such excess stone and deductions for the weights thereof will be made from contract payments for new stone. In addition to the above, stone, which has been delivered to the site and has been lost or wasted or otherwise not properly incorporated into the final required work, shall be deducted from the quantity for which payment is to be made.

(2) Final Surveys. Survey work and measurements required for determination of excess volume computations for stone materials shall be performed in the presence of the Contracting Officer. Notify the Contracting Officer not less than 3 days in advance of each survey. In the event of unavailability of the Contracting Officer, perform the survey and certify to the Contracting Officer that it complies with the specifications. Cross section surveys shall be taken perpendicular to the axis of the structures. Elevations and soundings shall be taken on lines 25 feet apart measuring along the structure reference line, with the readings at 5-foot intervals and at breaks in the grade along the line. Other survey intervals and readings may be used if deemed appropriate or advisable by the Government's on-site representative. Additional cross sections, elevations, and soundings may be taken if determined necessary by the Government's on-site representative. Determination of quantities will be made by the Government's on-site representative and having once been made, will not reopen, except on evidence of collusion, fraud or obvious error. Prior to performing any work under this Section, coordinate all operations with the Government's on-site representative so that excess volume surveys will be made at the appropriate time. The surveys made under paragraph CHECK SURVEYS may be used when deemed appropriate by the Government's on-site representative, as part of the surveys required herein. Stone quantity computations shall be based entirely upon weights of new stone as determined from carrier displacement or certified scale weight tickets. Existing stone placed in lieu of new stone from off-site sources is excluded from measurement and payment.

1.1.2.1 Unit of Measure

Unit of measure: ton

1.1.3 Revetment Repairs

1.1.3.1 Earthwork, Small Repairs

When less than 10,000 cubic yards of earthwork is specified, the earthwork shall be considered Earthwork, Small Repairs.

- a. Payment will be made for costs associated with grading and excavation, which includes furnishing all equipment, labor and materials, and performing all clearing, except range clearing, drift removal and disposal of debris; grading and excavation; disposal of material from grading, whether or not used for fill; dressing; and all other operations incidental thereto.
- b. Earthwork, Small Repairs will be measured for payment based upon on-site surveys, taken under the direction of the Government Representative, of the required grading or excavation areas prior to commencement and on-site surveys taken after completion of the work. All quantities removed will be determined from these surveys computed to the nearest cubic yard.
- c. Unit of measure: cubic yard.

1.1.4 Reworking and Utilizing Existing Stone Materials
1.1.4.1 Payment

Payment for reworking existing stone materials and utilizing existing stone in lieu of required materials from off-site sources will be paid for separately from construction utilizing materials obtained from off-site sources.

1.1.4.2 Measure

Reworking and Utilizing Existing Stone Materials will be measured for payment based upon square feet of surface area of existing protection.

1.1.4.3 Unit of Measure

Unit of measure: ton and/or square foot.

1.2 REFERENCES

The publications listed below form a part of this specification to the extent referenced. The publications are referred to within the text by the basic designation only.

ASTM INTERNATIONAL (ASTM)

| | |
|-------------|--|
| ASTM C 127 | (2007) Standard Test Method for Density |
| ASTM C 33 | (2007) Standard Specification for Concrete Aggregates |
| ASTM C 295 | (2008) Petrographic Examination of Aggregates for Concrete |
| ASTM D 3370 | (2008) Sampling Water from Closed Conduits |
| ASTM D 1429 | (2008) Specific Gravity of Water and Brine |

| | |
|----------------|---|
| ASTM D 2487 | (2006e1) Soils for Engineering Purposes (Unified Soil Classification System) |
| ASTM D 3740 | (2008) Minimum Requirements for Agencies Engaged in the Testing and/or Inspection of Soil and Rock as Used in Engineering Design and Construction |
| ASTM D 4791 | (2005e1) Flat Particles, Elongated Particles, or Flat and Elongated Particles in Coarse Aggregate |
| ASTM D 4992 | (2007) Evaluation of Rock to be Used for Erosion Control |
| ASTM D 5312 | (2004) Evaluation of Durability of Rock for Erosion Control Under Freezing and Thawing Conditions |
| ASTM D 5313 | (2004) Evaluation of Durability of Rock for Erosion Control Under Wetting and Drying Conditions |
| ASTM D 5519 | (2007) Particle Size Analysis of Natural and Man-Made Riprap Materials |
| ASTM D 75 | (2003) Standard Practice for Sampling Aggregates NATIONAL INSTITUTE OF STANDARDS AND TECHNOLOGY (NIST) |
| NIST HB 44 | (2007) NIST Handbook 44: Specifications, Tolerances, and other Technical Requirements for Weighing and Measuring Devices U.S. ARMY CORPS OF ENGINEERS (USACE) |
| COE CRD-C 144 | (1992) Standard Test Method for Resistance of Rock to Freezing and Thawing |
| COE CRD-C 148 | (1969) Method of Testing Stone for Expansive Breakdown on Soaking in Ethylene Glycol |
| COE CRD-C 169 | (1997) Standard Test Method for Resistance of Rock to Wetting and Drying |
| EM 1110-2-1601 | (1994; Change 1) Hydraulic Design of Flood Control Channels |
| EM 1110-2-1906 | (1970; Change 1 and 2) Laboratory Soils Testing |

1.3 DEFINITIONS
1.3.1 Bank Stabilization

This paragraph explains certain terminology which is common to construction of bank stabilization work along shoreline and which may not be self explanatory in the subsequent applicable provisions of the technical specifications and on the drawings.

1.3.1.1 Revetments

The term "revetment" applies to various types of stabilization structures that are constructed along the river approximately parallel to the current. The revetments are constructed of stone or piling.

1.3.2 Stone Protection

Stone Protection is defined as a system which includes a layer of bedding material or layers of filter material beneath a layer or layers of riprap. Stone protection is placed around structures in slack water or within a dewatered site. Stone protection may also be used to protect channel banks when it is placed in the dry or in slack water.

1.3.3 Riprap

Riprap is defined as a material having a gradation band similar to those specified in EM 1110-2-1601, Chapter 3, uniform graded material. Riprap is normally produced by mechanical methods, with a jaw crusher and grizzly after the stone has been mined by blasting in a quarry. Riprap gradations have a maximum top size of 3.5 tons.

1.3.4 Graded Stone

Graded Stone is defined as material with gradations that are produced by the mining technique and minimal additional processing other than the use of a skeleton bucket or a bar grizzly. The gradation band have more fines than riprap and have gradations with top size up to 3.5 tons and could be classified as being well graded.

1.3.5 Channel Protection

Channel protection is stone placed in a current as revetment, dikes, or slope paving without the use of a separate layer of bedding or filter material. In this type of environment, bedding sand or geotextiles and materials with gradation bands with a top size of 150 mm (6 inches) will not stay where placed.

1.3.6 Shoreline Protection

Shoreline Protection is defined as a system of bedding or filter materials and stone used to protect coastlines of lakes and oceans and for harbor protection.

1.3.7 Revision of Bidding Schedule Quantities

The estimated quantities of stone listed in the BIDDING SCHEDULE were computed on the basis of stone having a percentage of voids and a bulk specific gravity (saturated surface dry (SSD) basis) as shown in the above table based on water having a unit weight of 62.4 pounds per cubic foot. When the bulk specific gravity (SSD) of the stone to be used in the work is other than that shown in the above table, the estimated quantities will be revised by multiplying them by the

fraction which results when the bulk specific gravity (SSD) of the stone furnished is divided by the value shown in the above table for each respective stone gradation. Revision for the percentage of voids will likewise be made. The Contracting Officer will issue a modification to the contract in accordance with the Contract Clause, CHANGES, in Section 00 41 00 CONTRACT CLAUSES to adjust the estimated quantities in the BIDDING SCHEDULE. The revised quantities will then be the quantities from which the allowable fifteen percent (15%) variation in estimated quantity, for payment purposes, will be determined as defined in Contract Clause, VARIATIONS IN ESTIMATED QUANTITIES, in Section 00 41 00 CONTRACT CLAUSES.

1.3.7.1 Re-revision of Estimated Quantities

If during the progress of the work it is determined that the delivered stone actually placed has a percentage of voids or a bulk specific gravity range different from that on which the BIDDING SCHEDULE is based, the BIDDING SCHEDULE will be further revised in accordance with paragraph REVISION OF BIDDING SCHEDULE QUANTITIES.

1.3.8 Bulk Specific Gravity of Stone and Redesign

If the Contractor, after award of the contract, requests approval of stone from a source(s) which has a range of bulk specific gravity (SSD), whose limits are lower or higher than the specified design range of 2.5 to 2.9 as specified in paragraph MATERIAL QUALITY, consideration will be given to revising the project design through modification of the design range under the following conditions:

- a. The modification of the specified design range will result in a savings to the Government. Such savings shall not be subject to Contract Clause VALUE ENGINEERING-CONSTRUCTION of Section 00 41 00 CONTRACT CLAUSES.
- b. Only one (1) such proposal for modification will be allowed. In addition, the required completion time shall not be extended more than thirty (30) calendar days as a result of redesign for any reason, including acts of the Government.
- c. The modified design range of bulk specific gravity (SSD) to be used shall not have a lower limit of less than 2.30 nor higher than 3.50.
- d. The stone sections of the required structure are to be redesigned by the Government. Such redesign will be based upon the Contractor's proposed modifications to the specified design range of bulk specific gravity (SSD) and will include any required revisions to allowable tolerances. Only one such redesign will be made. A charge of \$5,000 will be assessed the Contractor whether the redesign is used or not.

(1) The above redesign will be made upon written request from the Contractor. The request shall state the proposed modified design range of bulk specific gravity (SSD). With the request, submit records of laboratory tests performed on the proposed stone source(s) indicating the range of bulk specific gravity (SSD) of the stone source(s). The laboratory tests shall have been performed by a Government validated commercial laboratory.

(2) The Government shall be allowed a period of twenty-one (21) calendar days after receipt of the request to make the redesign. The redesign will be made based upon the lower limit of the proposed modified design range of bulk specific gravity (SSD) furnished.

(3) Upon completion, redesign will be furnished to the Contractor, including revised estimated quantities for the BIDDING SCHEDULE, based upon the average bulk specific gravity (SSD) of the proposed modified design.

(4) Upon receipt of the redesign, the Contractor shall make a proposal to modify the allowable range.

e. Any proposal to modify the specified design range shall be submitted within fifteen (15) calendar days after receipt of the Government's redesign and shall include a statement as to the savings which will result from the modification. If a formal proposal is not submitted within the time limit, the work shall be performed in accordance with the specified design, in which case the Contractor shall not be allowed to use stone having a bulk specific gravity (SSD) less than the specified design range.

f. The statement of savings shall be in the form of a proposed revised BIDDING SCHEDULE showing unchanged unit prices for the revised quantities.

g. If the Contractor elects to perform the work in accordance with the redesign, the estimated quantities to be shown in the BIDDING SCHEDULE will be the quantities derived from the Government's redesign. See the above paragraph REVISION OF BIDDING SCHEDULE QUANTITIES.

1.4 SUBMITTALS

The following shall be submitted in accordance with Section 01 33 00 SUBMITTAL PROCEDURES:

1.4.1 SD-03 Product Data

- a. Riprap; G
- b. Filter Material; G
- c. Gaging Table Data
- d. Filter Rock

Stone hauling vessel gaging tables and a copy of the data and calculations used for the preparation of the tables.

- e. Bulk Specific Gravity of Stone and Redesign; G

A formal proposal to perform the work in accordance with the redesign, within fifteen (15) calendar days after receipt of the Government's redesign; if the Contractor proposes to utilize stone having a specific gravity outside of the specific design range, and as a result thereof, the

Government provides the Contractor with a redesign. The submittal shall include a statement of the direct savings to the Government and tabulation in the form of a revised BIDDING SCHEDULE showing unchanged unit prices for the revised quantities.

1.4.2 SD-04 Samples

- a. Stone; G

Suitable stone samples prior to delivery of any such material to the worksite if stone is not from one of the stone sources listed at the end of this section.

1.4.3 SD-07 Certificates

- a. Rip Rap Specific Gravity
- b. Filter Fabric
- c. Filter Rock

Certificates of compliance attesting that the materials meet specification requirements.

- d. Laboratory; G

A copy of the documents provided by the Materials Testing Center (MTC) at Corps of Engineers Waterways Experiment Station (CEWES) or other governmental agency, that validates that the laboratory can perform the required tests. The individual tests shall be listed for which the validation covers along with the date of the inspection.

- e. Weigh Scale Certification

A copy of the certification from the regulation agency attesting to the scale's accuracy.

- f. Certified Weight Scale Tickets

A copy of each certified weight scale ticket 5 working day(s) after weighing.

1.5 QUALITY ASSURANCE

1.5.1 Stone

1.5.1.1 General

All stone shall be durable material as approved by the Contracting Officer. Selected stone from the required excavation may be used if it satisfies all requirements as to quality and dimensions. In case an unlisted source is to be used, show that an adequate quantity of material is available and provide quality test data. Stone shall be of a suitable quality to ensure permanence in the structure and in the climate in which it is to be used. It shall be free from cracks, blast fractures, bedding, seams and other defects that would tend to increase its deterioration from natural causes. Inspections for cracks, fractures, seams and defects shall be made by visual examination. If, by

visual examination, it is determined that 20 percent or more of the stone produced contains hairline cracks, then all stone produced by the means and measures which caused the fractures shall be rejected. A hairline crack that is defined as being detrimental shall have a minimum width of 4 mil and shall be continuous for one-third the dimension of at least two sides of the stone. The stone shall be clean and reasonably free from soil, quarry fines, and shall contain no refuse. The stone shall be clean and adequately free from all foreign matter. Any foreign material adhering to or combined with the stone as a result of stockpiling shall be removed prior to placement.

1.5.1.2 Sources

Stone shall be furnished from any of the sources listed at the end of this section, or at the option of the Contractor may be furnished from any other source designated by the Contractor and accepted by the Contracting Officer, subject to the conditions herein stated. If the Contractor proposes to furnish stone from a source not currently listed at the end of this section, the Government will conduct a quarry investigation and evaluate the quality test data provided by the Contractor to determine whether acceptable stone can be produced from the proposed source. Satisfactory service records on other work may be acceptable. In order for stone to be acceptable on the basis of service records, stone of a similar size must have been placed in a similar thickness and exposed to weathering under similar conditions as are anticipated for this contract, and must have satisfactorily withstood such weathering for a minimum of 20 years. If no such records are available, the Government will conduct tests to assure the acceptability of the stone. In addition to an acceptable 5 year service record, the Contracting Officer has the option to elect to have representative samples taken and tested.

a. List of Sources. On the basis of information and data available to the Contracting Officer, stone meeting the quality requirements of these specifications has been produced from the sources listed at the end of this section.

a. List of Sources

(1) Category I Sources: Category I sources have been inspected and evaluated within the last five years by the Government and have produced stone materials of acceptable quality from satisfactory geological formations. The Category I sources have previously demonstrated effective quality control programs at the source and the test results of the materials furnished have been verified that some material are of satisfactory quality. In a like manner, the source would be capable of providing the quality, quantity, and gradation of required stone materials. Further evaluation and testing of the source will not be required unless the preparation of the required demonstration stockpile reveals an adverse condition not previously taken into account.

(2) Category II Sources: Category II sources either have not been inspected or evaluated within the past five years or have had a deficiency in the past which may or may not affect its qualifications to provide stone materials for this project. Deficiencies may include, but are not limited to: ineffective quality control program; unsatisfactory production techniques; unacceptable quality of material in the geological formation being quarried; insufficient quantities of required materials; or unsatisfactory durability of stone materials previously furnished. These factors of this kind do not disqualify the source for this project. A current inspection and evaluation of the source by the Contractor would be necessary to determine whether acceptable stone can be produced from the proposed source before allowing the source to proceed with preparation of demonstration stockpiles. Disapproval of a proposed Category II source based on

the inspection and evaluation would necessitate having the Contractor name a replacement source from the Category I list.

b. Selection of Source. Designate in writing only one source or one combination of sources from which he proposes to furnish stone. If the Contractor proposes to furnish stone from a source not listed at the end of this section, he may designate only a single unlisted source for stone and he shall notify the Contracting Officer at least 60 workdays before the stone leaves the quarry. It is the Contractor's responsibility to determine that the stone source or combination of sources selected is capable of providing the quality, quantities, and gradation needed and at the rate needed to maintain the scheduled progress of the work. Samples for acceptance testing shall be provided in accordance with paragraph EVALUATION TESTING below. If a source for stone so designated by the Contractor is not accepted for use by the Contracting Officer, the Contractor may not propose other sources but shall furnish the stone from a source listed in Category I at the end of this section with no additional payment.

c. Acceptance of Materials. Acceptance of a source of stone is not to be construed as acceptance of all material from that source. The right is reserved to reject materials from certain localized areas, zones, strata, or channels, when such materials are unsuitable for stone as determined by the Contracting Officer. The Contracting Officer also reserves the right to reject individual units of produced specified materials in stockpiles at the quarry, all transfer points, and at the project construction site when such materials are determined to be unsuitable. During the course of the work, the stone may be tested by the Government, if the Contracting Officer determines that testing is necessary. If such tests are determined necessary, the testing will be done in the Government's testing laboratory or commercial laboratory selected by the Government. Materials produced from a listed or unlisted source shall meet all the requirements herein. The cost of testing will be at the Government's expense. During the contract period, both prior to and after materials are delivered to the job site, visual inspections and measurements of the stone materials may be performed by the Contracting Officer. If the Contracting Officer, during the inspections, finds that the stone quality, gradation or weights of stone being furnished are not as specified or are questionable, re-sampling and re-testing by the Contractor shall be required. Sampling of the delivered stone for testing and the manner in which the testing is to be performed shall be as directed by the Contracting Officer. This additional sampling and testing shall be performed at the Contractor's expense when test results indicate that the materials do not meet specified requirements. When test results indicate that materials meet specified requirements, an equitable adjustment in the contract price will be made for the sampling and testing. Any material rejected shall be removed or disposed of as specified and at the Contractor's expense.

1.6 CONSTRUCTION TOLERANCES

The finished surface and stone layer thickness shall not deviate from the lines and grades shown by more than the tolerances listed below. Tolerances are measured perpendicular to the indicated neatlines. Extreme limits of the tolerances given shall not be continuous in any direction for more than five (5) times the nominal stone dimension nor for an area greater than 200 square feet of the structure surface.

NEATLINE TOLERANCES
 ABOVE NEATLINE BELOW NEATLINE

| MATERIAL | inches above neatline | below neatline |
|-----------------|----------------------------------|---------------------------|
| Filter Layer: | +3 inches | -2 inches |
| Riprap: | +8 inches | -4 inches |
| Fill Sand: | +2 inches | -1 inch |

The intention is that the work shall be built generally to the required elevations, slope and grade and that the outer surfaces shall be even and present a neat appearance. Placed material not meeting these limits shall be removed or reworked as directed by the Contracting Officer. Payment will not be made for excess material which the Contracting Officer permits to remain in place.

PART 2 PRODUCTS

2.1 FILTER MATERIAL

Filter material shall consist of Filter Stone and Geotextile. The filter material shall be composed of tough, durable particles, adequately free from thin, flat and elongated pieces, and shall contain no organic matter nor soft, friable particles in quantities considered objectionable by the Contracting Officer. The aggregate shall meet the quality requirements of ASTM C 33. Grading shall conform to the following requirements:

PERMISSIBLE LIMITS

U.S. STANDARD SIEVE PERCENT BY WEIGHT, PASSING
 FILTER STONE

| | |
|-------|-----|
| 6 in. | 95% |
| 3 in. | 50% |
| 1 in. | 5% |

The filter materials shall be well-graded between the limits shown. At least one test shall be performed on material placed for each specified gradation in accordance with ASTM C 136. A representative sample weighing not less than 100 pounds shall be removed from the filter layer placed at locations directed by the Contracting Officer. All points on individual grading curves obtained from representative samples of filter material shall lie between the boundary limits as defined by smooth curves drawn through the tabulated gradation limits plotted on ENG FORM 2087 or similar form. The individual gradation curves within these limits shall not exhibit abrupt changes in slope denoting either gap grading or scalping of certain sizes or other irregularities which would be detrimental to the proper functioning of the filter. Geotextile shall be as specified in Section 31 05 19 GEOTEXTILES.

2.2 STONE

2.2.1 General

2.2.1.1 Evaluation Testing of Stone

If the Contractor proposes to furnish stone from an unlisted source, the Contractor shall have evaluation tests performed on stone samples collected from the proposed source. The quarry

investigation shall be performed by a registered geologist or registered engineer. The tests to which the stone shall be subjected include petrographic examination (ASTM C 295), bulk specific gravity (SSD), unit weight, absorption (ASTM C 127), resistance of stone to freezing and thawing (COE CRD-C 144 or ASTM D 5312), and if argillaceous limestone and sandstone are used, resistance to wetting and drying (COE CRD-C 169 or ASTM D 5313). The laboratory to perform the required testing shall be validated based on relevant paragraphs of ASTM D 3740, and no work requiring testing shall be permitted until the laboratory has been inspected and validated. The first inspection of the facilities shall be at the expense of the Government and any subsequent inspections required because of failure of the first inspection shall be at the expense of the Contractor.

a. Bulk Specific Gravity Range. All stone shall have a minimum bulk specific gravity, saturated surface dry (SSD), of 2.50 and a maximum bulk specific gravity of not more than 2.90 based upon water having a unit weight of 62.4 pounds per cubic foot. The method of test for bulk specific gravity (SSD) shall be ASTM C 127.

b. Petrographic Examination. Stone shall be evaluated in accordance with ASTM C 295 which shall include information required by ASTM D 4992, paragraph 10. COE CRD-C 148 shall be used to perform Ethylene glycol tests required on rocks containing smectite as specified in ASTM D 4992 and on samples identified to contain swelling clays.

d. Samples. Samples of stone from a source not listed at the end of this section shall be taken by a representative of the Quarry under the supervision of the Contracting Officer for testing and acceptance prior to delivery of any stone from this source to the site of the work. Information provided with the samples shall include the location within the quarry from which the sample was taken along with a field examination of the quarry. The field examination shall include the information outline in ASTM D 4992, paragraph 7. Samples shall consist of at least three pieces of stone, roughly cubical in shape and weighing not less than 150 pounds each from each unit that shall be used in the production of the required stone. If the source is an undeveloped quarry, or if the operation has been dormant for more than one year such that fresh samples are not available, the Contractor shall expose fresh rock for 20 feet horizontally and for the full height of the face proposed for production, prior to the field evaluation. The Contracting Officer may also require documentation of subsurface exploration of an undeveloped quarry in order to determine whether or not sufficient reserves are available. The samples shall be shipped at the Contractor's expense to a laboratory validated by the government to perform the required tests.

e. Tests. Conduct the tests in accordance with applicable ASTM and Corps of Engineers methods of tests, given in the Handbook for Concrete and Cement, in a laboratory validated by the government. The cost of testing shall be borne by the Contractor.

2.2.1.2 Riprap Stockpile

Storage of riprap, stone, or filter stone at the worksite is not to be confused with off-site stockpiling of riprap, stone, or filter stone. If the Contractor elects to provide off-site stockpiling areas, the Contracting Officer shall be notified of all such areas. The Contractor's stockpile shall be a maximum of 12 feet high and formed by a series of layers of truckload dumps, where the rock essentially remains where it is placed. Subsequent layers shall be started 10 feet from the edge of the previous layer so that the rock will not roll down the edges of the previous layers. The first layer shall be a maximum of 6 feet high. After being stockpiled, any riprap, stone, or filter

stone which has become contaminated with soil or refuse shall not be put into the work unless the contaminating material has been removed from the riprap, stone, or filter stone prior to placement.

a. **Worksite Stockpile.** Riprap, stone, or filter stone delivered to the work sites, which requires temporary storage landward of top of slope, shall be placed in a container suitable for storing the riprap, stone, or filter stone without waste, or a sand-clay-gravel or crushed stone pad may be constructed for the storage area and removed upon completion of the work. If the sand-clay-gravel or crushed stone pad method is used, the pad shall have a minimum thickness of at least 6 inches. The container or sand-clay-gravel or crushed stone pad method shall be subject to approval prior to delivery of the riprap, stone, or filter stone. Upon completion of the work, the storage areas shall be cleaned of all storage residues and returned to their natural condition. Temporary storage of riprap, stone, or filter stone at the worksite will be allowed, provided the stockpile toe of the riprap, stone, or filter stone be no closer than 60 linear feet from the closest edge of the shoreline's upper top slope, and the amount shall not exceed 200 tons unless otherwise approved.

b. **Off-site Stockpile.** In areas where riprap, stone, or filter stone is stockpiled for placement, the area shall have excess rock removed prior to completion of work. All rock and spalls greater than 3 inches in diameter shall be removed. Where rocks may have become buried due to soft ground or operation of the equipment, the rock shall be disposed of as directed. After the rock has been removed, the storage area shall be graded, dressed, and filled to return the ground surface as near as practical to the condition that existed prior to construction.

2.2.2 Riprap

Only quarried stone shall be used. Riprap quality shall be as specified in paragraph GOVERNMENT TESTING AND STUDIES, subparagraph STONE. Stone shall be well graded and shall conform to the table(s) below.

TABLE 1

(FOR RIPRAP "1/4 Ton")

| PERCENT LIGHTER LIMITS OF STONE BY WEIGHT (SSD) | WEIGHT, LB. |
|--|--------------------|
| 95-100% | 1,000 |
| 0-50% | 500 |
| 0-5% | 75 |

Gradation curves to be provided

2.2.3 Filter Fabric

See SECTION 31 05 22 GEOTEXTILES for filter fabric.

PART 3 EXECUTION

2.3 DEMONSTRATION SECTION

Prior to placement of stone, construct a section of stone protection consisting of toe stone, riprap, and filter layers to demonstrate his proposed operations for production placement. The section shall demonstrate procedures and capability of grading, placing toe stone and bank protection within the tolerances specified. The demonstration section shall be 100 feet in length and shall conform to all applicable specifications.

2.3.1 Method and Equipment

Methods and equipment employed for placement shall demonstrate the adequacy for use in placement of toe stone, riprap, and filter layers and shall conform with the requirements specified. The quantities of all materials placed within the section shall be accurately tabulated and provided immediately to the Contracting Officer for comparison with computed quantities.

2.3.2 Demonstration Section Evaluation

Do not proceed with placing stone protection prior to the approval of the demonstration section. Within a period of 7 days after completion of the section, the Contracting Officer shall determine the adequacy of the section to function as part of the permanent construction. The Contractor will be notified as to the acceptability of the section and may be directed to modify methods of construction and remove the section if necessary.

2.3.3 Removal of Demonstration Section

If removal of the demonstration section is required, it shall be conducted in such a manner as to maintain the integrity of the underlying subgrade. The Contractor shall make arrangements for disposal in areas not located on the site.

2.4 BASE PREPARATION

Areas on which filter layers and riprap are to be placed shall be graded and/or dressed to conform to cross sections shown on the contract drawings within an allowable tolerance of plus 2 inches and minus 4 inches from the theoretical slope lines and grades. The prepared base shall be approved by the Contracting Officer. Where such areas are below the allowable minus tolerance limit they shall be brought to grade by fill with earth similar to the adjacent material or with sand fill and then compacted to a density equal to the adjacent in place material. Subaqueous areas on which filter materials and riprap are to be placed shall be graded and/or dressed to conform to cross sections shown on the contract drawings within an allowable tolerance of plus 1 foot and minus 2 feet from the specified slope line and grades. Where such areas are below the allowable minus tolerance limit they shall be filled with sand fill. As an alternative, these areas may be filled with filter material. Immediately prior to placing the geotextile and filter stone, the prepared base will be inspected by the Contracting Officer and no material shall be placed thereon until that area has been approved. Prepared base layer shall not be exposed to incoming water unless authorized by the Contracting Officer.

2.5 PLACEMENT OF FILTER LAYERS

2.5.1 General

Filter layers, composed of geotextile and a 6-inch layer of filter stone shall be placed on the prepared base as described below, in accordance with the details shown on the contract drawings, and within the limits either shown on the contract drawings or staked in the field. A tolerance of plus 2 inches and minus 1 inch from the slope lines and grades shown on the contract drawings will be allowed in the finished surface of the filter layers, except that the extreme of this tolerance shall not be continuous over an area greater than 200 square feet.

2.5.2 Geotextile

Installation of geotextile shall be as specified in Section 31 05 22 GEOTEXTILES USED AS FILTERS.

2.5.3 Placement of Filter Material on Geotextile

Filter material shall be spread uniformly on the geotextile to the slope lines and grades as indicated on the contract drawings and in such manner as to avoid damage to the geotextile. Placement shall begin at the bottom of the area to be covered and continue up slope. Subsequent loads of material shall be placed against previously placed material in such a manner as to ensure a relatively homogenous mass. Placing of filter stone by methods which tend to segregate the particle sizes within the filter layer will not be permitted. Any damage to the surface of the geotextile during placement of filter stone shall be repaired before proceeding with the work. Compaction of material placed on the geotextile will not be required, but shall be finished to present an adequately even surface, free from mounds or windrows.

2.5.4 Placement of Filter Material on Prepared Base

Filter material shall be spread uniformly on the prepared base to the slope lines and grades as indicated on the contract drawings and in such manner as to avoid damage to the prepared base. Placement shall begin at the bottom of the area to be covered and continue up slope. Subsequent loads of material shall be placed against previously placed material in such a manner as to ensure a relatively homogenous mass. Placing of stone by methods which tend to segregate the particle sizes within the filter layers or cause mixing of the separate layers will not be permitted. Any damage to the surface of the prepared base during placement of the material shall be repaired before proceeding with the work. Compaction of material placed on the prepared base will not be required, but each layer shall be finished to present an adequately even surface, free from mounds or windrows.

2.6 PLACEMENT OF RIPRAP

2.6.1 General

Riprap shall be placed on the filter layers specified in paragraph FILTER MATERIAL within the limits shown on the contract drawings.

2.6.2 Placement

Under water placement rates shall be used when the top of the layer to be placed is covered by more than 3 feet of water.

2.6.2.1 Above Water

Riprap shall be placed in such manner as to produce a well graded mass of rock with the minimum practicable percentage of voids, and shall be constructed within the specified tolerances to the lines and grades shown on the drawings. Placement shall begin at the bottom of the area to be covered and continue up slope. Subsequent loads of material shall be placed against previously placed material in such a manner as to ensure a relatively homogenous mass. A tolerance of plus 6 inches or minus 6 inches from the slope lines and grades shown on the drawings will be allowed in the finished surface of the riprap, except that either extreme of such tolerance shall not be continuous over an area greater than 200 square feet. The average tolerance of the entire job shall have no more than 50 percent of the tolerance specified above. No stone shall be dropped through air from a height greater than 3 feet. The drop height of riprap with a top size greater than 500 pounds shall be less than 1 foot, but can be increased by placing a cushioning layer of sand or other protective material on top of the geotextile before placing the riprap, or other methods deemed necessary if demonstrated in the field to not damage the geotextile. The larger stones shall be well distributed and the entire mass of stones in their final position shall be roughly graded to conform to the gradation specified in paragraph RIPRAP, subparagraph GENERAL. The finished riprap shall be free from objectionable pockets of small stones and clusters of larger stones. Placing riprap in layers will not be permitted. Placing riprap by dumping into chutes or by similar methods likely to cause segregation of the various sizes will not be permitted. Placing riprap by dumping it at the top of the slope and pushing it down the slope will not be permitted. No equipment shall be operated directly on the completed stone protection system. The desired distribution of the various sizes of stones throughout the mass shall be obtained by selective loading of the material at the quarry or other source, by controlled dumping of successive loads during final placing, or by other methods of placement which will produce the specified results. All dump trucks used in placing the riprap shall be equipped with bottom hinged tailgates. The gate releasing mechanism shall be arranged so that it may be operated only from, at, or near the front of the truck. Rearranging of individual stones will be required to the extent necessary to obtain a well-graded distribution of stone sizes as specified above. Maintain the stone protection until accepted by the Contracting Officer; any material displaced by any cause shall be replaced, with no additional payment, to the lines and grades shown on the drawings.

2.6.2.2 Under Water

Prior to starting work, submit the proposed method of placing riprap under water. Riprap to be placed in the wet if necessary shall be done during periods of low water levels. The riprap shall be placed in two passes, with the second pass perpendicular to the first pass.

2.7 PLACEMENT OF HAND-PLACED RIPRAP

2.7.1 General

Hand-placed riprap shall be placed on the filter material specified in paragraph FILTER MATERIAL within the limits shown. Stone shall conform to the requirements of paragraph RIPRAP. Except for spalls for wedging, stone shall be roughly rectangular in shape of which the least dimension shall be not less than one-third the length.

2.7.2 Placement

The riprap shall be carefully placed by hand in such a manner that adjacent stones are in close contact and, in general, have their greatest dimensions across the slope. "Through stones" shall be well-distributed throughout the mass and the sum of their cross sections, parallel to the slope being protected, shall be not less than two-thirds of such area. As used in this specification a "through stone" is defined as a stone whose dimension normal to the surface being riprapped is not less than the full depth of the riprap. Placement shall begin at the bottom of the area to be covered and continue up slope. Subsequent loads of material shall be placed against previously placed material in such a manner as to ensure a relatively homogenous mass. Placement shall begin at the bottom of the area to be covered and continue up slope. Subsequent loads of material placed on the slope shall be immediately adjacent to previously placed material in such a manner to ensure a relatively homogenous mass. The riprap along the lower edge of an area shall consist of the largest stones set in a trench so as to form a band. Except for spalls used to fill voids between larger stone, no stone shall be used in the exposed face of the riprap which will extend less than one-half the thickness of the riprap. Spaces between the larger stones shall be filled with spalls and smaller stones of the largest feasible size to form a compact mass. Spalls and small stone shall not be place in nests in lieu of larger size stone. A tolerance of plus or minus 6 inches from the slope lines and grades shown will be allowed in the finished surface of the riprap paving, except that the extreme of this tolerance shall not be continuous over an area greater than 200 square feet.

2.8 CORRECTIVE EARTHWORK

2.8.1 Grading

Grading shall consist of the sloping of banks damaged by failures and the preparation of the subgrade. Most of the grading will be in areas where mechanical equipment can be used, but some hand grading may be required. All grading and filling shall be done to the lines and grades as staked in the field or as specified. Material used in making fills or restoring the subgrade shall be free from roots, brush or other debris. Each layer shall be thoroughly compacted to a density at least equal to that of the adjacent undisturbed earth.

2.8.2 Excavation

Excavation shall be required in some failures where protrusion of stone above adjacent surface is objectionable. Where excavation is specified, the subgrades shall be excavated to the extent necessary. Large areas may not require excavating throughout, but excavation to the depths specified above will be required only for a distance of 5 feet inside the perimeter of the failure. Most of the excavation can be accomplished by mechanical means, but some hand work around the edges will be required. All work shall be to the lines and grades as staked in the field or as specified. Material resulting from the operation shall be used for making fills where required as specified in paragraph GRADING.

2.9 TESTS AND INSPECTIONS

Surveys made by the Contractor are required on each material placed for determining that the materials are acceptably placed in the work. Make checks as the work progresses to verify lines, grades and thicknesses established for completed work. At least one (1) check survey as specified below shall be made for each twenty-five (25) foot section as shown as practicable after completion. Following placement of each type of material, the cross section of each step of the

work shall be approved by the Contracting Officer before proceeding with the next step of the work. Approval of cross sections based upon check surveys shall not constitute final acceptance of the work. Cross sections shall be taken on lines 25 feet apart, measured along the structure reference line, with readings at 5-foot intervals and at beaks along the lines. However, other cross section spacing and reading intervals may be used if determined appropriate by the Contracting Officer. Additional elevations and soundings shall be taken as the Contracting Officer may deem necessary or advisable. The surveys shall be conducted in the presence of an authorized representative of the Contracting Officer, unless this requirement is waived by the Contracting Officer.

a. Above Water: The elevation of stone above the water surface shall be determined by the use of a leveling instrument and a rod having a base 12 inches in diameter. If approved by the Contracting Officer other means may also be used.

b. Below Water: For portions of the work that are under water, sounding surveys shall be performed either by means of a sounding pole or a sounding basket weighing about 8 1/2 pounds, each of which has a base measuring 12 inches in diameter.

c. Gage Board: The gage shall be checked prior to any survey. The Contractor shall install a gage board at the project site.

d. Electronic Depth Recorder Method: When using an electronic depth recorder the following procedures shall be used.

(1) The depth recorder shall be calibrated and adjusted for the gage, with check bar, at least six (6) times within a normal eight (8) hour work day.

(2) Normal calibration times shall be at the beginning of the work day, mid-morning, close of morning's work, start of afternoon's work, mid-afternoon, and the end of the day.

(3) Further calibrations shall be performed whenever there is any malfunction within the depth recorder or transducer which might affect the soundings, a major gage change, or change in water temperature due to industrial discharge or other causes.

(4) The check bar shall be set at approximately the deepest sounding in the area to be sounded.

(5) The depth recorder shall be calibrated to read at low water datum.

(6) When checking the calibration at mid-morning, end of morning, mid-afternoon and end of work, the same setting used for the previous calibration shall be used.

(7) If the calibration check does not agree with the previous calibration, the depth recorder shall be calibrated to the proper setting.

(8) Under no circumstances shall the setting of the depth recorder be changed between calibrations.

e. Electronic Depth Recorder: The survey depth recorder used must be a standard model acceptable to the Contracting Officer using a sounding chart that can be read directly to the

nearest foot and estimated to the nearest tenth (0.1) of a foot. Accuracy shall be better than 1/2 of 1 percent.

f. Tagline Method of Horizontal Location Along Station: If a tagline is used with a depth recorder, the soundings shall be marked with a fix every 5 feet.

g. Predetermined Transit Angle Method or Ranges Method: The interval between predetermined angles or ranges along a sounding line shall not exceed 200 feet along the entire length of the sounding line. No predetermined angle shall form an intersection with the sounding line of less than 45 degrees.

h. Speed of the Sounding Boat: When sounding, the speed of the sounding boat shall be as constant as possible, preferably between 180 and 220 feet per minute.

i. Checking Gage: The gage shall be checked prior to each calibration and recorded on the sounding chart or in the field notes.

2.10 Gradation Tests for Stone

2.10.1 Gradation Test Method for Riprap

Gradation tests shall be performed in accordance with ASTM D 5519.

3.10.2 Standard Test Method for Gradation of Riprap, Graded Stone, and Filter Stone

a. Select a representative sample (Note No. 1), weigh and dump on hard stand.

b. Select specific sizes (see example) on which to run "individual weight larger than" test. (See Note No. 2). Procedure is similar to the standard aggregate gradation test for "individual weight retained".

c. Determine the largest size stone in the sample. (100 percent size)

d. Separate by "size larger than" the selected weights, starting with the larger sizes. Use reference stones, with identified weights, for visual comparison in separating the obviously "larger than" stones. Stones that appear close to the specific weight must be individually weighed to determine size grouping. Weigh each size group, either individually or cumulatively.

e. Paragraph d above will result in "individual weight retained" figures. Calculate individual percent retained (heavier than), cumulative percent retained, and cumulative percent passing (lighter than). Plot percent passing, along with the specification curve on ENG Form 4794-RM 4794-R.

NOTE NO. 1: Sample Selection: The most important part of the test and the least precise is the selection of a representative sample. No "standard" can be devised; larger quarry run stone is best sampled at the shot or stockpile by given direction to the loader; small graded stone is best sampled by random selection from the transporting vehicles. If possible, all parties should take part in the sample selection and agree before the sample is run that the sample is representative.

NOTE NO. 2: Selection of Size for Separation: It is quite possible and accurate to run a gradation using any convenient sizes for the separation, without reference to the specifications. After the test is plotted on a curve, then the gradation limits may be plotted. Overlapping gradations with this method are no problem. However, it is usually more convenient to select points from the gradation limits, such as the minimum 50 percent size, the minimum 15 percent size, and one or two others, as separation points. For these types of stone gradations the separation points need to be selected as the smallest size stone at each break in the gradation specified.

Part 3 EXECUTION

3.1 Filter Layers

3.1.1 General

Perform gradation tests to assure compliance with contract requirements and shall maintain detailed records. The bedding material, filter materials and/or sand fill shall be sampled in accordance with ASTM D 75 and tested in accordance with ASTM C 136. Perform the tests before and after surveys of each layer of stone protection material placed.

3.1.2 Reporting

Reporting shall be in accordance with paragraph GRADATION TEST.

3.2 Revetment Repairs

Inspect the revetment repairs for compliance with the contract requirements and record the inspection of all operations including, but not limited to, the following:

- a. Bank grading, excavating or reshaping damaged drains through the paving, placing graded material into areas, and disposing of waste material.
- b. Breaking out pavement within specified limits.
- c. Disposition of cleared material, drift, and other debris.

IR SITES 7 AND 18
 COVER AND REVETMENT
 HUNTERS POINT SHIPYARD

05-29-2009

EXAMPLE GRADATION
 SPECIFICATIONS

| PERCENT LIGHTER BY WEIGHT | STONE WEIGHT IN LBS. |
|---------------------------|----------------------|
| 100 | 400 - 160 |
| 50 | 160 - 80 |
| 15 | 80 - 30 |

EXAMPLE WORKSHEET

| STONE SIZE LBS. | INDIVIDUAL WT. RETAINED | INDIVIDUAL PERCENT RETAINED | CUMULATIVE PERCENT RETAINED | PERCENT PASSING |
|--------------------|----------------------------|--------------------------------|--------------------------------|--------------------|
| 400 | 0 | 0 | 0 | 100 |
| 160 | 9,600 | 30 | 30 | 70 |
| 80 | 11,200 | 35 | 65 | 35 |
| 30 | 8,000 | 25 | 90 | 10 |
| <30 | 3,200 | 10 | 100 | - |

TOTAL 32,000 pounds

NOTE: Largest stone 251 pounds

IR SITES 7 AND 18
 COVER AND REVETMENT
 HUNTERS POINT SHIPYARD

05-29-2009

GRADATION TEST DATA SHEET

Quarry _____ Type of Stone Tested _____

Date of Test _____ Testing Rate _____

TEST REPRESENTS

Contract No. _____ District _____ Tons _____

| | | |
|-------|--|--|
| | | |
| | | |
| | | |
| TOTAL | | |

GRADATION

Stone Size (lbs) Weight Retained Individual % Retained Cumulative % Ret. % Pass Specification % Finer by wt

| | | | | | |
|------------------|--|--|--|--|--|
| | | | | | |
| | | | | | |
| | | | | | |
| | | | | | |
| | | | | | |
| | | | | | |
| | | | | | |
| | | | | | |
| | | | | | |
| | | | | | |
| | | | | | |
| Total Weight | | | | | |
| Max Size Stone = | | | | | |

Remarks: _____

I certify that the above stone sample is representative of the total tonnage covered by this test report.

Contractor Representative _____
 Government Representative _____]

STONE SOURCES

LATITUDE/
LONGITUDE

QUARRY LOCATION, ADDRESS,
& TELEPHONE NUMBER

MAIN OFFICE ADDRESS
& TELEPHONE NUMBER

[STATE]

[]

[]
[]
[]
[]

[]
[]
[]
[]

[]

[]
[]
[]
[]

[]
[]
[]
[]

[STATE]

[]

[]
[]
[]
[]

[]
[]
[]
[]

[]

[]
[]
[]
[]

[]
[]
[]
[]

END OF SECTION