

Design Speed (mph)	Shy line offset (ft)	Flare rate inside shy line (a:b)	Flare rate outside shy line (a:b)
60	8.0	26:1	14:1
50	6.5	21:1	11:1
40	4.5	16:1	8:1
30 and less	3.5	13:1	7:1

- NOTE:**
- Each unit consists of three segments each of which have a different random masonry pattern as shown. All three segments are to interlock with each other to vary the order.
  - Sealant for the real joint covers the perimeter joint of the capstone, sides, and top and sides of the footing.
  - Precast the entire wall section, no cast-in-place is allowed.
  - Minimum concrete cover 2" unless shown otherwise.

**BENDING DIAGRAMS**

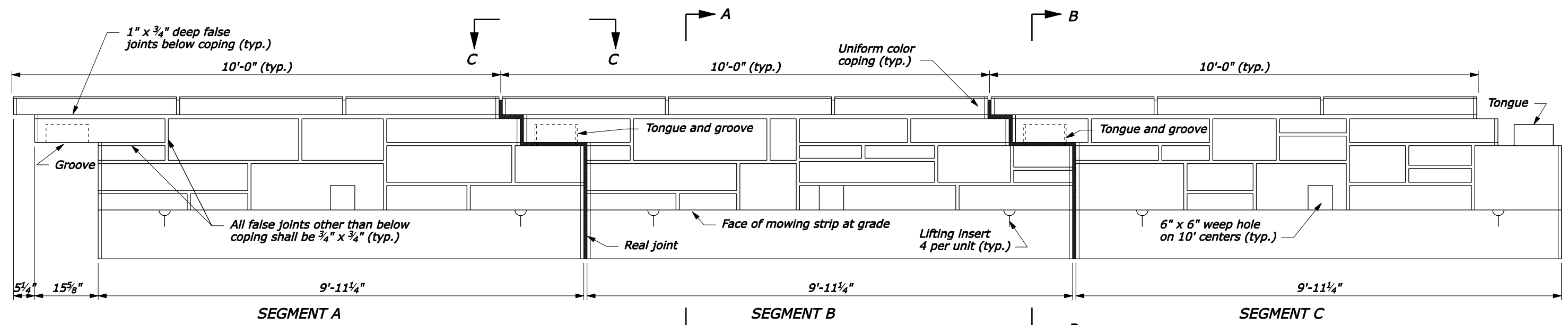

**PRECAST CONCRETE GUARDWALL**

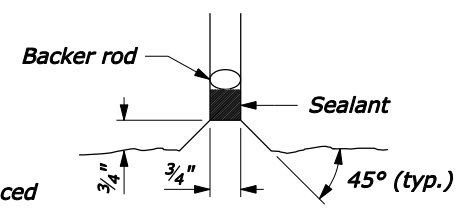
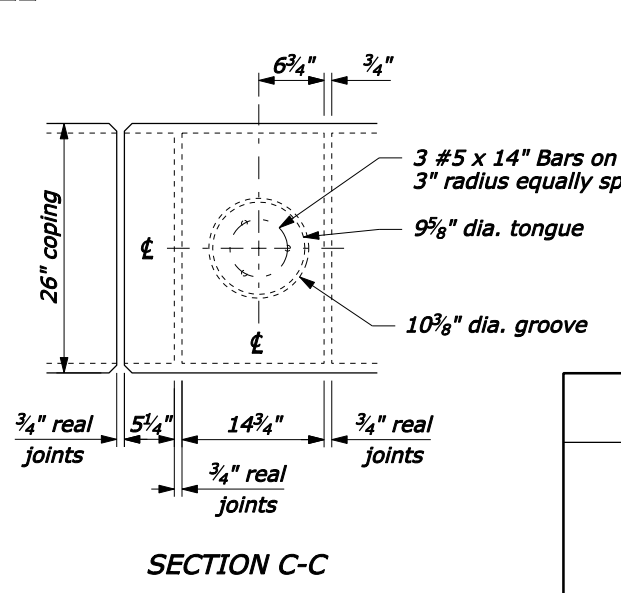
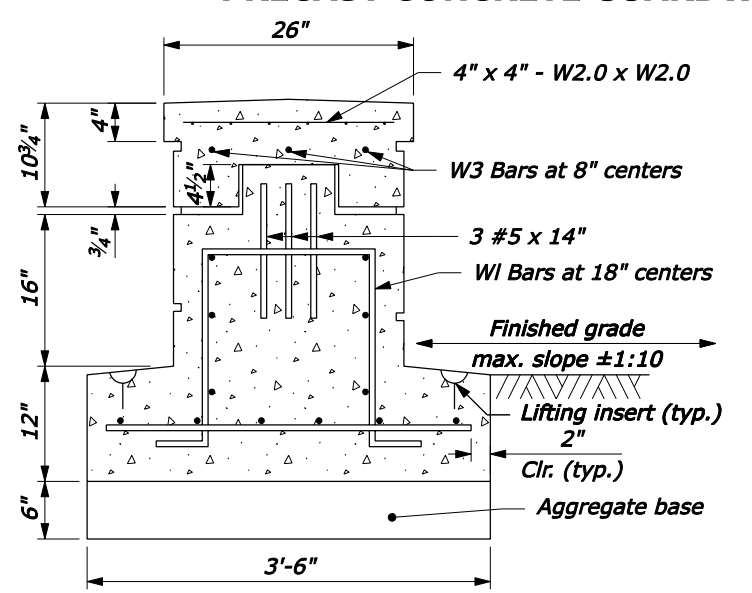
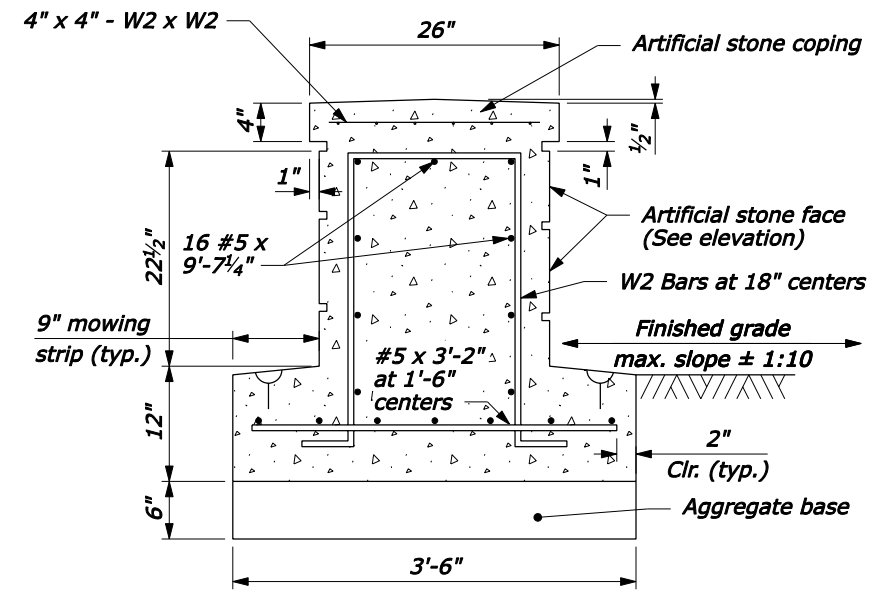

U.S. DEPARTMENT OF TRANSPORTATION  
FEDERAL HIGHWAY ADMINISTRATION  
FEDERAL LANDS HIGHWAY

U.S. CUSTOMARY STANDARD

**PRECAST CONCRETE GUARDWALL, TYPE 1**

STANDARD APPROVED FOR USE 3/1990  
REVISED: 4/1994 6/2005

STANDARD 618-2

F:\StdDraw\std1802.dgn [US Customary] 16-Jun-2005 02:29 PM