

ARMY LOGISTICIAN

40 YEARS 1969-2009

JANUARY-FEBRUARY 2009

The 3d Sustainment Brigade: A Modular Unit in Iraq

The U.S.-U.K. Road to Interoperability
Improving Materiel Readiness for the Joint Warfighter

PB 700-09-01 Headquarters, Department of the Army
Approved for public release; distribution is unlimited.

ARMY LOGISTICIAN

PROFESSIONAL BULLETIN OF UNITED STATES ARMY LOGISTICS

PB 700-09-01
VOLUME 41, ISSUE 1
JANUARY-FEBRUARY 2009

- 1 **From CASCOM: Identifying Logistics Requirements Early Improves Warfighting Capabilities**—David B. Crum
- 2 **Securing Khabari Crossing in Kuwait**—Major Demetria S. Walker, USAR
- 4 **Where the Rubber Meets the Road**—Specialist Richard L. Rzepka
- 6 **Sense and Respond: Logistics at the Unit Level**
—Major Michael F. Hammond
- 8 ***3d Sustainment Brigade in Iraq***
Modular Transformation and the 3d Sustainment Brigade
—Colonel Darrell K. Williams, Lieutenant Colonel Lillard D. Evans,
and Captain Brittany R. Warren
- 11 **Logistics Convoys and the Intelligence Mission**—Captain Jennifer Hurrle
- 14 **Distribution Operations in MND-North**—Major Charlie Ward
- 18 **Engineers Breaking New Ground in the Sustainment Brigade**
—Major Anne V. Taylor
- 23 **Establishing Modular Human Resources Operations in Iraq**
—Captain Shaunarey Amos
- 26 **Integrating Financial Management Operations in a Logistics Support Environment**—Lieutenant Colonel Russell A. Holscher
- 28 **Nonlethal Engagements as a Sustainment Mission**
—Captain Lloyd E. Warren III and Captain Brittany R. Warren
- 34 **The Health of the Command**—Colonel Linwood B. Clark
- 36 **Supporting Immediate Response 2008**—Staff Feature
- 40 **Improving Materiel Readiness for the Joint Warfighter**—Major Eric McCoy
- 43 **The Road to Interoperability**—Major Susan Carson, British Army
- 46 ***Spectrum***
Army Logistics Knowledge Management and SALE
—Dr. Nicholas J. Anderson
- 51 **Operational Logistics Planner for the Modular Army**—Thomas W. Chavers
- 52 **R & R: Reading and Reviews**
- 54 **News**
- 58 **Log Notes**
- 59 **Writing for Army Logistician**
- 60 **Index of Army Logistician Articles—2008**

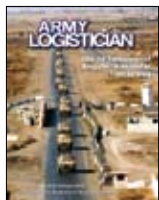

Cover: In the current operating environment, Army logistics units are often required to fill force protection roles in addition to their traditional missions. On the cover, the 104th Transportation Company, 927th Combat Sustainment Support Battalion (CSSB), conducts a convoy security operation near Contingency Operating Base Speicher in northern Iraq. The 927th CSSB was attached to the 3d Sustainment Brigade in support of Multi-National Division-North. The articles on pages 8 through 35 highlight the 3d Sustainment Brigade's diverse missions while it was deployed to Iraq as a completely modular sustainment brigade.

BOARD OF DIRECTORS

Chairman

Major General James E. Chambers
Commander
Army Combined Arms Support Command

Members

The Honorable Dean G. Poppo
Acting Assistant Secretary of the Army
Acquisition, Logistics, and Technology

Lieutenant General Mitchell H. Stevenson
Deputy Chief of Staff, G-4
Department of the Army

General Ann E. Dunwoody
Commander
Army Materiel Command

ARMY LOGISTICS MANAGEMENT COLLEGE

Colonel Shelley A. Richardson
Commandant

Barbara G. Mroczkowski
Assistant Commandant

STAFF

Robert D. Paulus, Editor
Kari J. Chenault, Associate Editor
April K. Morgan, Assistant Editor
Julianne E. Cochran, Assistant Editor
Louanne E. Birkner, Administrative Assistant

Graphic arts and layout by
RCW Communication Design Inc.

This medium is approved for the official dissemination of material designed to keep individuals within the Army knowledgeable of current and emerging developments within their areas of expertise for the purpose of enhancing their professional development.

By Order of the Secretary of the Army:

GEORGE W. CASEY, JR.
General, United States Army
Chief of Staff

Official:

JOYCE E. MORROW
Administrative Assistant to the
Secretary of the Army
0830402

World Wide Web address:
www.almc.army.mil/alog

Identifying Logistics Requirements Early Improves Warfighting Capabilities

BY DAVID B. CRUM

Comprehensive logistics supportability and sustainment planning for combat systems and equipment is an investment to ensure that our Soldiers receive warfighting capabilities that are reliable, maintainable, sustainable, and affordable. In the long run, these attributes enable commanders to sustain combat power in their warfighting platforms through improved materiel readiness. Identifying and communicating key logistics supportability and sustainment requirements to system materiel developers (program management teams) early in the capability development process are critical to achieving systems that are fully supportable when they are fielded. This ultimately supports Department of Defense and Army goals for reducing total ownership cost and the logistics footprint while meeting operational and system readiness objectives and improving logistics standardization and interoperability.

To further emphasize the criticality of materiel readiness within system requirements, Chairman of the Joint Chiefs of Staff Instruction 3170.01F, Joint Capabilities Integration and Development System, now mandates a sustainment key performance parameter (KPP) for materiel availability. The KPP is supported by two key system attributes, materiel reliability and ownership cost. These attributes tie readiness levels to resources and in-depth logistics supportability and sustainment planning early in the system development process. This front-end work enables the achievement of materiel readiness throughout a system's life cycle.

While many organizations have a role in determining and ultimately executing logistics supportability and sustainment at the platform level, the Army Training and Doctrine Command's (TRADOC's) capability development community is responsible for initially defining and documenting logistics supportability and sustainment attributes within warfighting systems. To assist the community, the Army Combined Arms Support Command (CASCOM) Integrated Logistics Support (ILS) Division, in conjunction with the Department of the Army G-4, the Army Evaluation Center, the Army Capabilities Integration Center's Logistics Division, and the Deputy Assistant Secretary of the Army for Acquisition Policy and Logistics, developed a logistics supportability handbook for defining and documenting logistics supportability and sustainment requirements for combat systems and equipment.

The handbook uses the 10 ILS elements—maintenance planning; manpower and personnel; supply support; support equipment; technical data; training and training support; computer resources support; facilities; packaging, handling, storage, and transportability; and

design interface—as a template for developing supportability and sustainment capabilities. It also includes sections on critical system characteristics such as reliability, availability, and maintainability (RAM); condition-based maintenance plus (CBM+); network-centric logistics; and life-cycle sustainment metrics. The handbook was distributed to TRADOC's centers and schools in March 2008 and was recently published as a supporting chapter within the updates to the TRADOC capability development document (CDD) and capability production document (CPD) writer's guides. The handbook is a great roadmap for taking us into the future.

The logistics supportability handbook contains an overview of each of the 10 ILS elements and a descriptive sample paragraph to use in developing each supportability and sustainment requirement. Since emerging systems differ in support and sustainment requirements, the capability developer can tailor the sample paragraphs to fit an individual system's needs when developing a CDD or CPD. During the initial staffing of the CDD or CPD, the CASCOM ILS Division performs an assessment of the documented logistics supportability and sustainment entries and assists the proponent author in shaping the requirements before they are staffed for validation and entrance into the formal approval process at the Army Requirements Oversight Council or the Joint Requirements Oversight Council. Since the initial publication of the handbook, the depth and scope of logistics supportability and sustainment requirements have improved substantially.

Logistics supportability and sustainment of combat platforms enable our operating forces to generate and sustain combat power. Defining support and sustainment requirements early in the system developmental process is essential to achieving materiel readiness goals throughout the life-cycle of a warfighting platform. The policies, goals, and objectives for improving system readiness are clear, and the TRADOC capability development community is at the forefront in effectively communicating them within capability documents.

We need to continue to reinforce this process because it makes sense and benefits the Soldier and the taxpayer. With well-conceived logistics supportability and sustainment structures, we can ensure that our Soldiers receive reliable, maintainable, sustainable, and affordable warfighting systems capable of out-performing any adversary on any battlefield. Support Starts Here!

DAVID B. CRUM IS THE DIVISION CHIEF FOR THE INTEGRATED LOGISTICS SUPPORT DIVISION IN CASCOM'S MATERIEL SYSTEMS DIRECTORATE. A RETIRED TRANSPORTATION AND ACQUISITION OFFICER, HE HOLDS A MASTER'S DEGREE IN PROCUREMENT AND ACQUISITION MANAGEMENT.

Securing Khabari Crossing in Kuwait

BY MAJOR DEMETRIA S. WALKER, USAR

The 513th Movement Control Team established crossing procedures and initially operated the Khabari border crossing between Kuwait and Iraq.

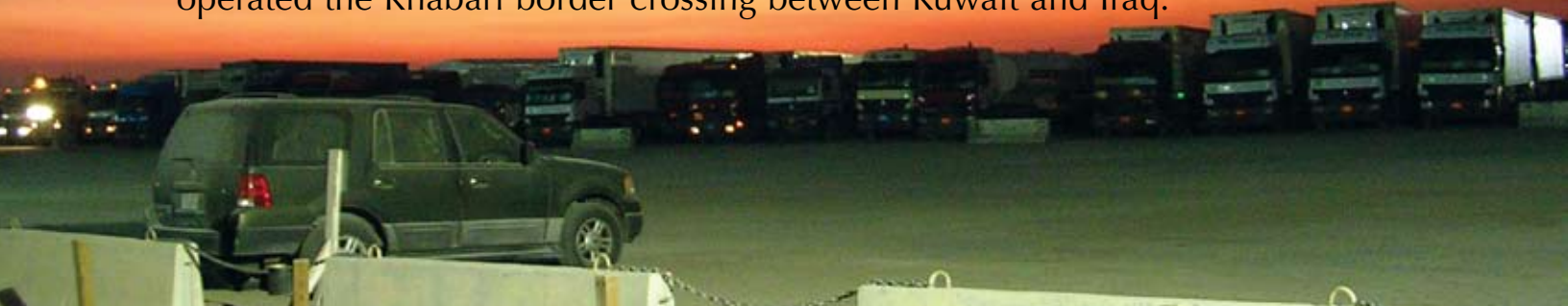

In July 2006, the 513th Movement Control Team (MCT), an Army Reserve unit from Victorville, California, deployed to Kuwait in support of Operation Iraqi Freedom. Its mission was to provide in-transit visibility of convoys traveling across the Iraq-Kuwait border; facilitate reception, staging, and onward movement of all ground forces redeploying into Kuwait; and perform container management functions. Its most significant accomplishment was helping to open the Khabari-Alawazem Crossing (called the Khabari Crossing).

Border Operations Before Khabari Crossing

When the 513th MCT first arrived in Kuwait, it was responsible for facilitating operations at the Navistar Border Crossing. Camp Navistar, located near the Kuwait-Iraq border, was the last node in Kuwait for processing convoy movements between Kuwait and Iraq. From there, the 513th MCT, along with KBR, managed northbound and southbound operations simultaneously.

Sustainment trucks await convoy movement into Iraq at the Navistar Crossing staging area.

It was the 513th MCT's responsibility to facilitate traffic flow along the main supply route for southbound convoys returning to Kuwait from Iraq. The MCT, along with interpreters assigned to the unit, worked with the Kuwaiti border security and customs officials when vehicles returning from Iraq with cargo or battle-damaged equipment were detained. Once the southbound convoys had been inspected by the Kuwaiti border security, all third country national (TCN) drivers proceeded to the entry control point to have their passports stamped for reentry into Kuwait. A representative from each convoy brought all documentation required for verification by the 513th MCT for the drivers to cross the border.

After the TCN passports were stamped, the drivers would enter the southbound lanes, where the contractor-operated sustainment trucks were inspected using a Mobile Vehicle and Cargo Inspection System (MVA-CIS). [MVACIS is a truck-mounted, gamma-ray scanning



Trucks go through the Mobile Vehicle and Cargo Inspection System at Camp Navistar, Kuwait.

Because of the outstanding job and successful mission performance by the 513th Movement Control Team, the 39th Movement Control Battalion submitted to the Department of Army a request that the Meritorious Unit Citation be awarded to the 513th MCT and the other units assigned to the 39th MCB during the OIF 06–08 rotation.



system that captures an image, similar to an x ray, of a truck's contents.] Military common user land transporters and coalition convoy assets were inspected by Navy customs.

In preparation for the anticipated opening of the new coalition crossing, the 513th MCT, along with KBR and the 39th Movement Control Battalion, conducted rock drills for units in Kuwait and Iraq, sustainment truck vendors, and incoming units during their leaders' reconnaissance missions.

Transitioning to Khabari Crossing

When the 513th MCT arrived in Kuwait and assumed operation of Navistar Crossing, the new border crossing at Khabari was under construction. Once Khabari Crossing was complete and Navistar Crossing was ready to close, the 513th MCT's mission was to help establish the Khabari Crossing operation.

After it was established, the Khabari Crossing, unlike Navistar, would operate as a throughput for convoys, not a staging yard. Staging would take place at other bases before heading for Khabari Crossing. At the new crossing, the previous convoy receptions, inspections, and consent procedures would no longer be used. Instead, civilian transporters would be issued a coalition crossing card—a plastic photo identification card with a bar code containing information linked to the Kuwaiti immigration and customs databases.

Another improvement included changes to the movement matrix. What was once a simple listing of civilian and military vehicles scheduled to go to Iraq each day became a very important document projecting all movement authorized to cross the military border on a given day. Every company and coalition force unit sending its convoys north coordinated with the movement control battalion to get on the movement list; otherwise, they could not cross the border. The improved movement matrix allowed for the total visibility of all vehicles crossing into Iraq and allowed vendors to pre-screen their cargo to ensure clearance.

After coordinating and implementing the new procedures, the 513th MCT conducted many rock drills to provide information to key leaders and vendors about

A 513th Movement Control Team officer briefs civilian contracting company representatives on the convoy operations for the new coalition crossing, Khabari Crossing.

Khabari Crossing and its operational differences from Navistar Crossing.

The First Test Run

The 513th MCT ensured that all communications lines were functioning and that everyone was aware of the anticipated time of arrival for the first incoming convoy. On 15 May 2007, the 513th MCT Soldier at the Iraq-Kuwait border radioed that he could see a south-bound convoy coming to Khabari. Finally, after 2½ to 3 years of planning, the new coalition crossing received its first convoy. Everyone was excited to see the U.S. convoy and responded with sighs of relief and then with cheers and hugs. After the planning, rock drills, and coordination, the 513th MCT successfully opened what may be the largest coalition crossing.

Khabari Crossing had been under construction for several years. Its concept was developed with the intent of replacing Navistar Coalition Crossing while retaining the basic task of controlling all civilian, military, and coalition traffic going into or coming back from Iraq. The 513th MCT had the responsibility and the satisfaction of bringing the vision to fruition. The border crossing between Iraq and Kuwait is now more efficient and more effective.

ALOG

MAJOR DEMETRIA S. WALKER, USAR, IS THE QUARTERMASTER AND TRANSPORTATION CAREER MANAGEMENT FIELD OFFICER FOR THE ARMY RESERVE COMMAND G-7. SHE SERVED AS A MOBILITY OFFICER AND EXECUTIVE OFFICER FOR THE 513TH MOVEMENT CONTROL TEAM AT CAMP NAVISTAR AND KHABARI CROSSING, KUWAIT. SHE HAS B.S. AND M.S. DEGREES FROM OKLAHOMA STATE UNIVERSITY AND IS A GRADUATE OF THE QUARTERMASTER OFFICER BASIC COURSE, THE TRANSPORTATION OFFICER ADVANCED COURSE, AND THE COMBINED ARMS AND SERVICES STAFF SCHOOL.

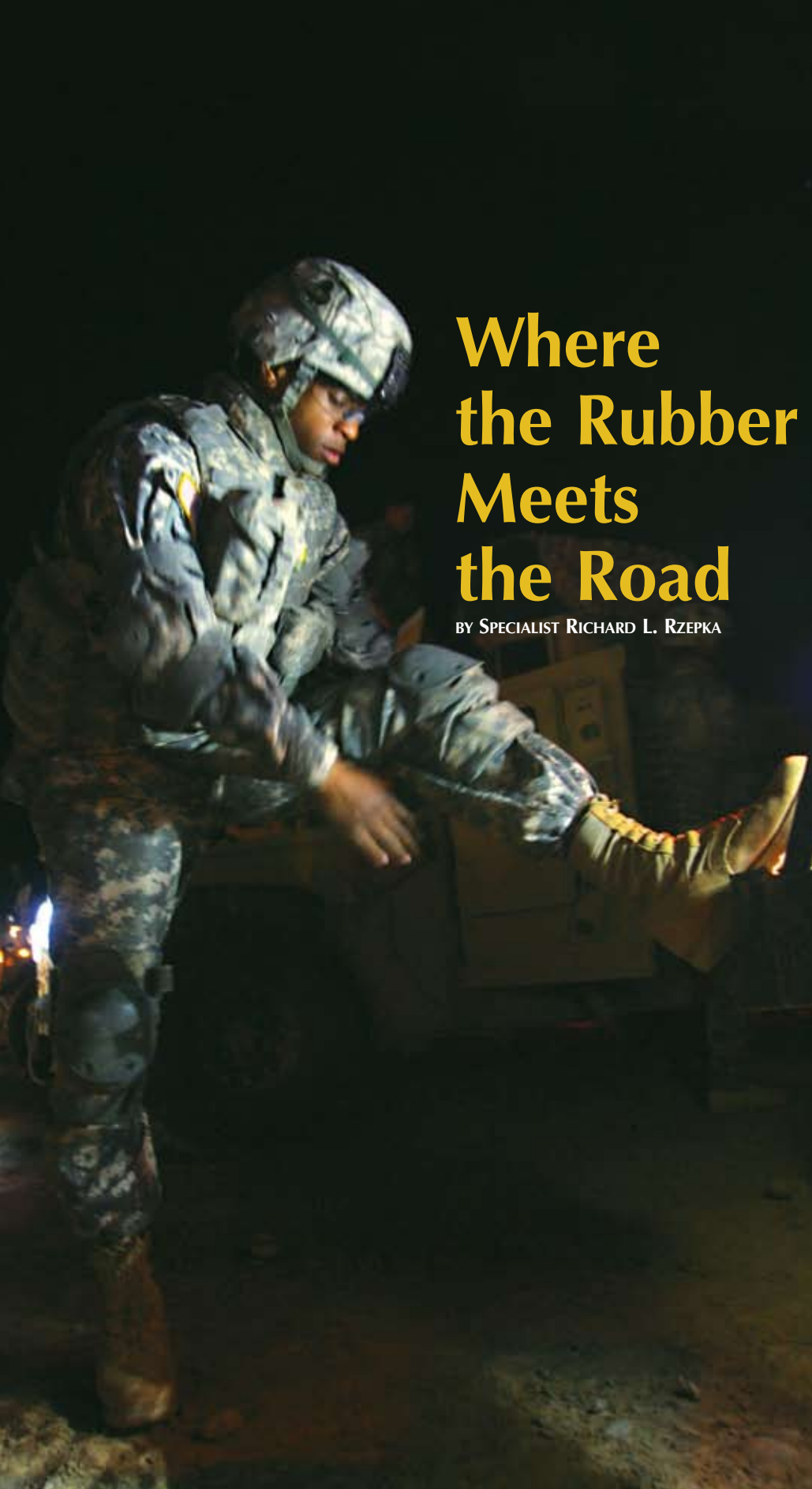

Where the Rubber Meets the Road

BY SPECIALIST RICHARD L. RZEPKA

Wars have been won and lost because of logistics. Logistics is an art form that, when executed properly, can mean the difference between life and death, glory and shame. As Benjamin Franklin commented on the importance of the logistician, “A little neglect may breed mischief. For want of a nail, the shoe was lost; for want of a shoe, the horse was lost; and for want of a horse, the rider was lost.”

The 426th Brigade Support Battalion (BSB), 1st Brigade Combat Team (BCT), 101st Airborne Division (Air Assault), eats, sleeps, and breathes logistics. After arriving in Iraq in early October 2007, the 426th BSB moved a staggering amount of crucial materiel to 1st BCT battalions in the Salah ad Din province. In their first 5 months in Iraq, the 426th BSB “Taskmasters” drove more than 89,000 miles on perilous roads to deliver their essential cargo—a feat that would make even the most seasoned United Parcel Service drivers wince. More than 1.5 million gallons of fuel have been delivered courtesy of these master logisticians, who take pride in knowing that they are at the heart of the fight for freedom in one of Iraq’s most volatile provinces.

“It’s critical to the overall mission here,” said Staff Sergeant Calvin Newkirk, a motor transporter with A Company, 426th BSB. “We keep everything rolling. Without supplies, the infantrymen couldn’t move.”

In providing direct support logistics operations in a combat environment, the Soldiers of the 426th BSB realize that they are a critical link in helping to safeguard the people of Iraq. “It’s like a chain reaction,” said Specialist Michael Velasquez, a logistics specialist who provides security for logistics convoys. “I’m

A Soldier straps on his knee pads before heading out to deliver concrete barriers to a police station in Ad Dawr, Iraq. The 426th “Taskmasters” were responsible for keeping the “Bastogne Infantrymen” well supplied.



A truck loaded with concrete barriers awaits departure to deliver the barriers to a police station in Ad Dawr, Iraq.

playing a role as a guardian for the convoy. To provide safety for them is to provide safety for the infantry so they get the supplies they need so they can support the Iraqi people. Together, we can complete the mission.”

One of the 426th BSB’s largest missions was supplying concrete barriers to an Iraqi police station in Ad Dawr, southeast of Tikrit. With a convoy of more than 30 vehicles that stretched over 3½ miles, the 426th delivered the much-needed ramparts in an effort to help secure the town and its residents. “We’re setting them up for success,” said Staff Sergeant Newkirk, who drove several hours to complete the mission. “The t-walls will provide the local nationals security and freedom of movement.

“Anything we can do for the Iraqis is a big help,” said Sergeant First Class James Faggart, a platoon sergeant in the BSB’s transportation section. “There’s a lot of good people here in Iraq, who really want to see change.” Faggart, who has seen

multiple deployments, said that the most dramatic change comes from the people stepping up and securing themselves. “The concerned local citizens are out there securing their own areas,” he said. “I think it’s been a big change since 2005 when we were here last time.” Faggart said that the most rewarding aspect of being a combat logistician is being able to bring his troops home safely after each mission. He credits the battalion’s success to four key principles: discipline, accountability, training, and maintenance. “My guys are focused; they’re not playing around out there,” said Faggart. “Where the rubber meets the road is where the Soldiers get out there and make it happen.” **ALOG**

SPECIALIST RICHARD L. RZEPKA IS AN ARMY JOURNALIST IN THE 101ST AIRBORNE DIVISION (AIR ASSAULT) PUBLIC AFFAIRS OFFICE. HE HOLDS A BACHELOR’S DEGREE IN MASS COMMUNICATIONS FROM WESTERN STATE COLLEGE IN COLORADO.

Sense and Respond: Logistics at the Unit Level

BY MAJOR MICHAEL F. HAMMOND

This article, the final in a series of three on sense and respond logistics, looks at the brigade combat team's existing capabilities and practices that follow the sense and respond approach.

The previous two articles examined the importance of using sense and respond logistics in a global security environment and on an insurgent battlefield. On the modern battlefield of insurgency, characterized by unconventionality and unpredictability, the U.S. military is best served by adopting sense and respond principals as logistics tenants of its own. Sense and respond logistics, a network-centric concept that enables logistics planners to provide precise logistics support to the warfighter, gives the combatant commander numerous options for planning mission support. At the unit level, brigade support battalion (BSB) planners' use of sense and respond increases the effectiveness and agility of logistics support within the brigade combat team.

Transformation and the BSB

Army transformation and the movement toward the brigade combat team unit configuration facilitated the practice of sense and respond logistics in the BSB. Before the Army transformed to the current brigade combat team structure, logistics support units operated on a four-tier system; support units were located at theater, corps, division, and brigade levels. Transformation removed some corps-level and all division-level units, consolidating logistics assets and capabilities at the brigade combat team level. Now, the BSB contains sufficient logistics assets for the unit commander to exercise sense and respond logistics in support of the brigade's combat operations. Army logisticians and planners are using sense and respond techniques to provide the brigade commander with logistics assets that were not at his disposal before transformation.

Before examining how the BSB operates within the sense and respond framework, one must understand the composition of the battalion and the assets it carries. The BSB performs several basic functions on the battlefield. First, the battalion's distribution company distributes food and water, paper supplies, petroleum and lubricants, construction and engineering materials, ammunition, personal demand items, complete assemblies like weapon systems and vehicles, medical

supplies, and repair parts. The distribution company's transportation section carries these sustainment stocks for the brigade. Second, the battalion's maintenance company performs field maintenance and vehicle recovery. Third, the battalion's medical company provides health services in the form of medical dispensary, pharmacy, mental health, and physician's assistant services. In a deployed environment, the medical company has surgeons on staff to stabilize combat casualties for transportation. Fourth, logistics planners in the battalion's support operations office plan and coordinate the fulfillment of the brigade combat team's sustainment requirements.

Within the BSB, the sense and respond concept is evident in three areas. First, logistics planners and unit commanders must design systems so that all personnel understand their roles. Second, key planners in the BSB must sense in real time what is happening on the battlefield and respond accordingly within the confines of the commander's overall intent. Finally, the BSB planners must dispatch assets in response to changes on the battlefield.

The Support Operations Officer

Numerous components of the BSB have sense and respond designs. One of the most important existing systems that facilitates sense and respond is the support operations officer (SPO) and his staff.

The SPO is undoubtedly the most critical logistics planner within the BSB. Every logistics effort begins with the influence and planning of the SPO. The SPO monitors the brigade's requests for supplies and coordinates the transportation support required to distribute them to combat units in the field. The SPO also coordinates with and provides oversight of the brigade's supply support activity warehouse. This warehouse is responsible for receiving, storing, and shipping supply items.

The SPO maintains oversight of the brigade's petroleum requirements—a critical activity in an armored or mechanized infantry brigade. The SPO is responsible for maintaining the readiness of the brigade's fleet of vehicles, weapon systems, and all other systems that

the brigade uses to conduct its missions. Some of the SPO's most critical tasks are coordinating and delivering medical supplies and overseeing the brigade's medical evacuation system. Since the Army began its transformation, the SPO has acquired contracting, property management, ammunition management, and mortuary affairs capabilities at the brigade level. Before the Army's transformation, these assets and personnel were located at division level or higher.

The SPO establishes working relationships and interacts with the division's sustainment brigade and corps-level support units. The sustainment brigade provides heavy transportation, supply, ammunition, fuel, and food and water support. The sustainment brigade's purpose is also to establish working relationships with its subordinate and lower-level support units.

Real-Time Logistics Data

Very early in their careers, logisticians are trained to anticipate a support unit's logistics requirements. Knowing the meaning of what is happening in real time on the battlefield is critical to an Army logistician's effectiveness. Huge amounts of data are generated during combat operations, and in continuous operations, such as Operation Iraqi Freedom, logisticians have access to volumes of historical data. Automated logistics programs organize logistics data and can provide them to logisticians in real time or near-real time.

Sufficient data streams allow logisticians and support unit commanders to focus on why something is happening on the battlefield. Such knowledge strengthens seamless logistics support because the SPO can dispatch capabilities exactly when they are needed. Another example of data management capability is the Blue Force Tracker, which is a system designed around satellite transmissions. The SPO avoids information obsolescence when he sets parameters so that the information that is gathered is geared toward the mission. Certain types of combat missions generate certain supply requests, so the information gathered is viable and actionable for the BSB.

Logistics Assets

Army logisticians have capitalized on shaping assets and capabilities into modular concepts, allowing planners and support unit commanders to dispatch logistics capabilities on the battlefield when the demand changes. By understanding his internal assets and establishing strong working relationships with higher-level support units, the combatant commander has at his disposal a multitude of logistics assets to assist in winning the fight.

For example, the distribution company, the largest company in the BSB, has several modular capabilities. The distribution company can provide modular assets

and capabilities for transportation, supply management, water purification and delivery, fuel storage and delivery, and ammunition storage and delivery. The distribution company also has modular capabilities for transporting the personnel of 2 infantry companies and 285 tons of commodities. In addition to its heavy and light transportation capabilities, the distribution company can operate an air delivery section to transport high-priority supply items by helicopter.

The maintenance company provides recovery assets to remove battle-damaged vehicles and armament technicians to repair weapons, artillery, and rocket systems in the brigade combat team. Radio and satellite repair personnel can be dispatched to unit locations to make repairs, and metalworks and welding technicians are also available to repair vehicles and equipment.

The medical company provides complete medical support to the brigade combat team while deployed to remote locations. Preventive medicine personnel are dispatched to unit locations to inspect dining facilities and base grounds to inhibit the spread of disease. Mental health doctors are dispatched to unit locations to provide mental health counseling and prevent combat-related stress incidents. The dispensary can hold up to 20 patients awaiting evacuation to higher-level medical facilities. The medical company also has dental care facilities for Soldiers and can provide a forward surgical team to combat locations.

Logistics synergy is clearly attainable at the battalion level. Capabilities, assets, and practices that support sense and respond logistics are already being used by Army logisticians and planners. The brigade combat team's BSB and SPO are organized and equipped to support sense and respond logistics. Every company within the BSB has modular capabilities that can be dispatched in support of combat and counterinsurgent operations.

Using logistics assets in modular form is not a new concept in logistics circles, and identifying logistics issues on the battlefield by way of data management is also not new. Sense and respond is already in use, but it has fallen short of being formally adopted by Army leaders as a planning requirement. Logisticians and planners must overcome cultural inhibitions to change and adopt sense and respond, which is critical to the U.S. military's success in the current global security environment.

ALOG

MAJOR MICHAEL F. HAMMOND IS THE S-3 OF THE 526TH BRIGADE SUPPORT BATTALION, 2D BRIGADE COMBAT TEAM, 101ST AIRBORNE DIVISION (AIR ASSAULT), WHICH IS CURRENTLY DEPLOYED TO IRAQ. HE HAS A MASTER'S DEGREE IN MILITARY LOGISTICS FROM NORTH DAKOTA STATE UNIVERSITY.



Modular Transformation and the 3d Sustainment Brigade

BY COLONEL DARRELL K. WILLIAMS, LIEUTENANT COLONEL LILLARD D. EVANS, AND CAPTAIN BRITTANY R. WARREN

The transformation of the 3d Infantry Division Support Command (DISCOM) into the 3d Sustainment Brigade as part of the Army's modular logistics transformation is complete, and our assessment is that the new modular design is a resounding success. The 3d Infantry DISCOM was the first logistics brigade in the Army to begin modular conversion (in conjunction with the modular conversion of the 3d Infantry Division's headquarters and brigade combat teams [BCTs]) shortly after its return from Operation Iraqi Freedom in 2003. Nearly 4 years after its transformation began, the 3d Sustainment Brigade became the first completely modular sustainment brigade deployed to Iraq or Afghanistan. The transformation was completed with the transfers of authority between the 125th Finance Battalion and the 82d Financial Management Company on 30 July 2007 and between the 22d Personnel Services Battalion and the 101st Human Resources Company on 28 November 2007.

The 3d Sustainment Brigade accepted the reins for sustainment of coalition forces within Multi-National Division-

North (MND-N) in Iraq from the 45th Sustainment Brigade on 26 June 2007, and its tour ended in September 2008. This article discusses the brigade's experience operating within this multicapable, extremely robust headquarters. We will also discuss areas of particular strength from our vantage point and adjustments we made to the structure to meet our specific mission and responsibilities.

Admittedly, our analysis of the 3d Sustainment Brigade's experience is colored by the conduct of the brigade's three distinct missions: sustaining coalition forces throughout MND-N and beyond as directed; providing mayoral and life support to 6,000 coalition forces personnel; and executing aggressive base defense and force protection operations on Contingency Operating Base (COB) Qayyarah West (Q-West) as the senior mission headquarters. The mayoral and base defense functions significantly increased our sustainment brigade headquarters' responsibilities beyond the sustainment mission. Yet, we accomplished all three mission sets with zero degradation in support. Much of this is a tribute to the increased capability of the modular design within

These charts show how the organizational structure of the 3d Sustainment Brigade changed over a year in Iraq. The 3d Special Troops Battalion was the only unit organic to the brigade; all other units were task-organized based on mission requirements.

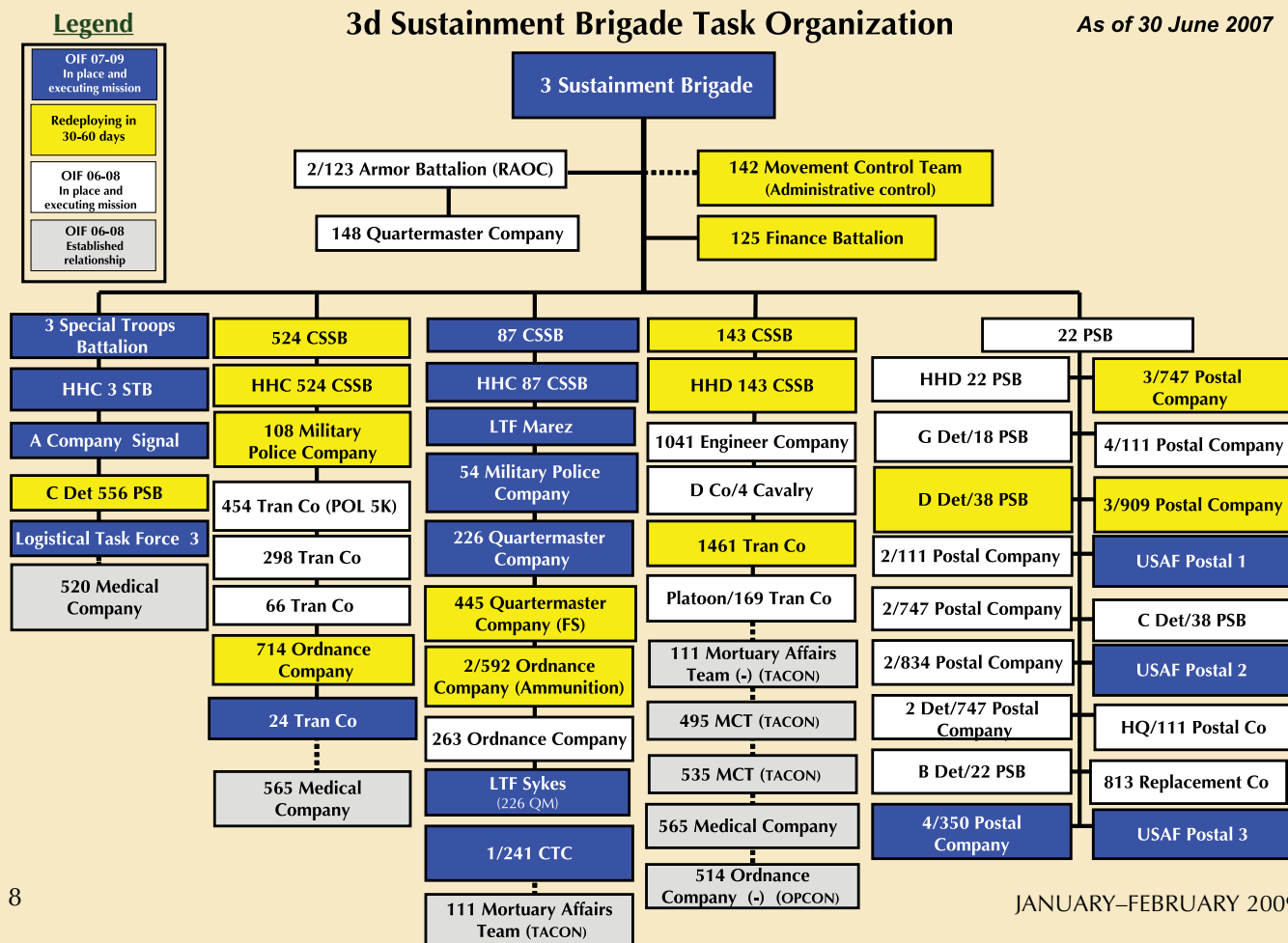

the brigade staff, the flexibility of combat sustainment support battalions, and the addition of a special troops battalion to the sustainment brigade structure.

Brigade Staff Changes

Within the brigade headquarters, several key enhancements allowed the brigade to successfully absorb complex, and in some cases nonstandard, mission sets. The increased capability in the support operations (SPO) section permitted greater oversight and execution of logistics operations, while the structure as a whole also allowed for better command and control of very diverse formations. The most significant adjustments were made in the S-3 section and the command group.

The S-3 was responsible for tracking the large number of relief-in-place and transfer-of-authority actions of subordinate units—an exceptionally critical task for deployed sustainment brigades. Tracking force rotations is, in fact, an S-3 task. However, it was the volume and fluidity of the unit transitions throughout our tenure that made this such an important requirement. Our S-3 transitions cell over-saw and synchronized the movement of 130 separate units

into and out of the theater of operations over the brigade's 15-month deployment, including 12 transitions between battalion headquarters.

Other missions for the S-3 included supporting the Iraqi Security Forces through the use of logistics transition teams and logistics training and advisory teams and incorporating nonlethal engagements into the operations. [See the article on page 28 for more information on the brigade's conduct of nonlethal engagements.] The S-3 section was enhanced with several key junior officers to manage these functions, and communication between the S-3 and the SPO was increased to facilitate the information flow required for success.

In the command group, two new positions were created to assist with the command and control of the massive sustainment brigade footprint: the brigade executive officer (XO) and the adjutant. The deputy commanding officer (DCO) worked tirelessly to integrate the mayor cell and base defense operations center functions with brigade headquarters operations. He also exercised day-to-day supervision of the special staff, another extremely critical task. The XO, on the other hand, focused on overall staff coordination, acting

Legend

CLT Casualty liaison team	HHQ Headquarters and headquarters detachment	OPCON Operational control	R5 Reception, rest and recreation, return to duty, replacement, and redeployment team
Co Company	HHSB Headquarters and headquarters service battery	OPS Operations	SOC Seaport operations company
CSSB Combat sustainment support battalion	HQ Headquarters	PL Platoon	STB Special troops battalion
CTC Cargo transfer company	HR Human resources	POL Petroleum, oils, and lubricants	TACON Tactical control
Det Detachment	LTF Logistics task force	PSB Personnel services battalion	Tran Transportation
FS Field services	MCT Movement control team	QM Quartermaster	USAF U.S. Air Force
HHC Headquarters and headquarters company	OIF Operation Iraqi Freedom	RAOC Rear area operations center	

3d Sustainment Brigade Task Organization

As of 30 June 2008

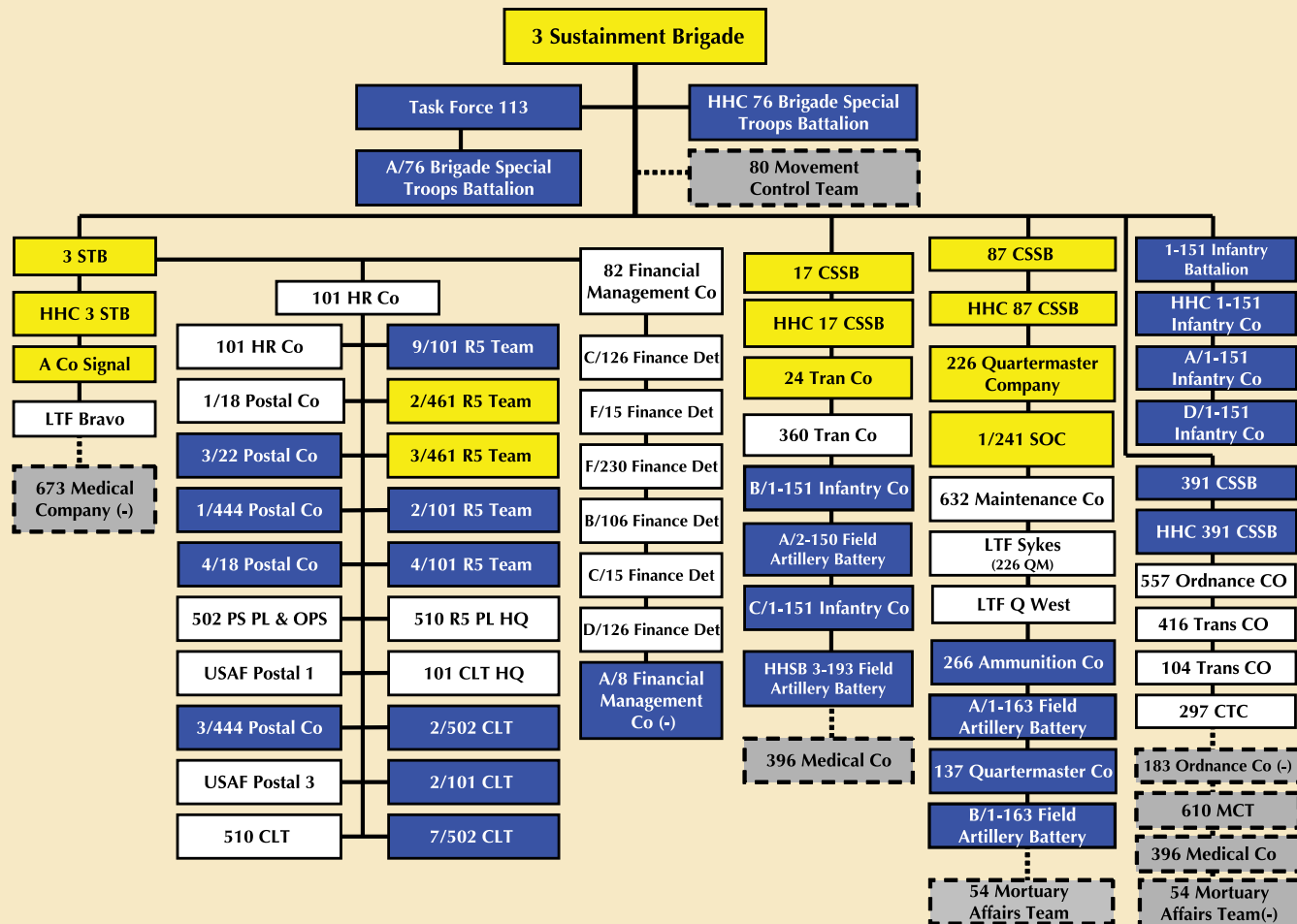

as a discrete entity from the DCO. The brigade adjutant proved critical to synchronizing command group functions. With the sheer quantity of the command group's work, and given the requirements for rest and relaxation leave, battlefield circulation, and other factors that removed the command group from the headquarters for periods of time, the XO and adjutant positions proved to be priceless additions.

In all cases, the sustainment brigade headquarters structure proved to be fully adept at providing oversight of diverse mission sets; this included the battalion headquarters, which fell under the brigade to conduct COB mayor and base defense operations. The expansion of military police, civil affairs, engineer (both assured mobility and project management functions), and other capabilities enhanced our ability to coordinate both laterally with supported BCTs and vertically with higher levels (the support command [expeditionary] and the MND-N task force).

Combat Sustainment Support Battalions

Another area that has benefited from the modular transformation is the combat sustainment support battalion (CSSB). CSSBs were the true lifeblood of general support (GS) logistics operations in MND-N. The CSSBs were extremely adaptable organizations that could deploy Soldiers to provide support away from their parent headquarters throughout the breadth of northern Iraq and often beyond. The 927th CSSB was located at COB Speicher, the 17th CSSB at COB Q-West, and the 87th CSSB at Forward Operating Base (FOB) Marez.

The CSSBs' operation of the GS hubs, along with their distribution support throughout MND-N and MND-Northeast (the Korean sector), was indispensable to the sustainment of coalition forces. They routinely conducted distribution operations across an area the size of Pennsylvania and on some of the most dangerous, improvised explosive device-riddled roads in Iraq. Unquestionably, the distribution of key commodities and supplies was the sustainment brigade's center of gravity, but these units also conducted nontraditional missions, such as logistics training for Iraqi Army units in coordination with the BCTs and nonlethal engagements with Iraqi citizens in coordination with Iraqi Security Forces and coalition forces. The enhancements to the brigade staff described above allowed for coordination and communication over huge geographic areas. In truth, all of the 3d Sustainment Brigade's units conducted these missions and worked to promote Iraqi self-reliance.

Special Troops Battalion

The most dynamic change as a result of modular transformation by far has been the inclusion of a special troops battalion (STB) in the sustainment brigade structure. The STB is the only unit organic to the sustainment brigade; all others were task-organized based on mission requirements. Before its deployment, the 3d STB comprised a headquarters and headquarters company (HHC), a financial management company (FMCO), a signal company, a chemical company, and a movement control team; its total troop strength was 633 personnel. The STB evolved significantly in theater to include an HHC, a signal company, an FMCO,

a human resources company, and a logistics task force providing life support at the strategic border crossing between Iraq and Turkey (the Harbur Gate).

The 3d STB was spread out over 23 different FOBs and COBs throughout MND-N and MND-West and comprised over 800 Soldiers and Airmen. Command and control of these diverse mission sets presented a challenge, but through aggressive circulation across the battlefield by leaders, use of detailed personnel accountability procedures, and integration with liaison officers at each key location, the STB was able to conduct its mission very successfully. Make no mistake about it: the STB evolved into a direct support organization with area support responsibilities equally as complex as those of the three CSSBs.

Perhaps the most significant difference in the sustainment brigade structure was the modular transformation of the finance and human resources organization from battalions to companies under the command and control of the STB. (See the articles beginning on pages 23 and 26 for more discussion on these transformations.) The SPO section absorbed the technical oversight roles, while several critical functions from the personnel services battalion were moved to the brigade S-1.

Our assessment after 15 months in the field in Iraq is that the new sustainment brigade structure is extremely flexible and capable of providing full-spectrum logistics, human resources, and finance support. Although there were some challenges to the modular transformation, the new sustainment structure truly works. **ALOG**

COLONEL DARRELL K. WILLIAMS WAS THE COMMANDER OF THE 3D SUSTAINMENT BRIGADE DURING ITS DEPLOYMENT TO OPERATION IRAQI FREEDOM 07-09. HE IS CURRENTLY SERVING AS THE EXECUTIVE OFFICER IN THE OFFICE OF THE DEPUTY CHIEF OF STAFF, G-4, DEPARTMENT OF THE ARMY. HE WAS PREVIOUSLY THE DEPUTY C-4, COALITION FORCES LAND COMPONENT COMMAND, AT CAMP ARIFFAN, KUWAIT. HE HOLDS AN M.S. DEGREE IN LOGISTICS MANAGEMENT FROM PENNSYLVANIA STATE UNIVERSITY. HE IS A GRADUATE OF THE ARMY COMMAND AND GENERAL STAFF COLLEGE AND THE SCHOOL OF ADVANCED MILITARY STUDIES AND IS A DISTINGUISHED GRADUATE OF THE NATIONAL WAR COLLEGE.

LIEUTENANT COLONEL LILLARD D. EVANS IS THE BRIGADE EXECUTIVE OFFICER OF THE 3D SUSTAINMENT BRIGADE. HE WAS PREVIOUSLY THE DIVISION TRANSPORTATION OFFICER, 3D INFANTRY DIVISION, AT FORT STEWART, GEORGIA. HE HOLDS AN M.S. DEGREE IN CIVIL ENGINEERING FROM THE UNIVERSITY OF ALABAMA AT BIRMINGHAM. HE IS A GRADUATE OF THE TRANSPORTATION OFFICER BASIC AND ADVANCED COURSES AND THE ARMY COMMAND AND GENERAL STAFF COLLEGE.

CAPTAIN BRITTANY R. WARREN IS THE BRIGADE ADJUTANT FOR THE 3D SUSTAINMENT BRIGADE. SHE SERVED AS A CHEMICAL PLATOON LEADER DURING OPERATION IRAQI FREEDOM 04-06 IN 2005. SHE HOLDS A B.S. DEGREE IN BIOLOGICAL ANTHROPOLOGY AND ANATOMY FROM DUKE UNIVERSITY AND IS A GRADUATE OF THE CHEMICAL OFFICER BASIC COURSE.



Logistics Convoys and the Intelligence Mission

BY CAPTAIN JENNIFER HURRELE

During its 15-month tour of duty, the 3d Sustainment Brigade relied on logistics convoys to gather intelligence on some of the most dangerous supply routes in Iraq.

Envision a logistics convoy in Iraq. While driving down a remote supply route, the convoy recognizes likely indicators of improvised explosive devices (IEDs), halts, and sets up a cordon to prevent civilian traffic from inadvertently setting off explosions. While awaiting an explosive ordnance disposal (EOD) team, the convoy conducts further checks of the area to ensure that no secondary devices are emplaced on the road and no snipers are concealed in the wadi, the dry riverbed next to the road.

After conducting these checks, the convoy commander interviews the local nationals who are pulling security on a nearby checkpoint. These tribesmen indicate that there has been a recent increase in traffic just off the route. The convoy commander quickly assesses the validity of this information and leads a team in an investigation of the site. Using this human intelligence, terrain analysis, and their understanding of historical patterns of activity in the area, the convoy soon discovers an enemy fighting position and a significant IED cache. The convoy secures the cache until the EOD team arrives to destroy it. Immediately after arriving at the nearest forward operating base, the convoy commander passes everything he has learned about the site to the maneuver unit that controls the battlespace. Thanks to the cache discovery, IED activity along the supply route is reduced for weeks to come. This is logistics intelligence at work.

Logistics Convoys Gathering Intelligence

Before the 3d Infantry Division deployed in 2007, its commander, Major General Rick Lynch, asserted on his “Preparation for Victory” signs that were posted throughout Fort Stewart, Georgia, that “Intelligence drives everything.” This proved to be especially true for the 3d Sustainment Brigade, which supported both the 25th Infantry Division and the 1st Armored Division in Multi-National Division-North during its deployment in 2007 and 2008.

Brigade combat teams (BCTs) can rely on traditional intelligence, surveillance, and reconnaissance (ISR) assets to complete their missions. However, in the

sustainment brigade, logistics convoys literally drive intelligence. The sustainment brigade’s S–2 (intelligence) section mission centers on the convoy as both a producer and a consumer of logistics intelligence.

The sustainment brigade’s S–2 section differs from a BCT’s S–2 section in that it does not conduct lethal targeting or own organic ISR assets. Nonetheless, logistics convoys function as some of the best intelligence collectors on the battlefield. Logistics convoys can exploit the parts of the battlespace where few maneuver patrols frequently travel. Convoys also detect changes on these routes. They drive the same roads every day and are successful at finding IEDs in part because they notice both physical and environmental differences in their surroundings.

Logistics convoys can also note the locations of suspicious activity and take photos of possible fighting positions and enemy infiltration and exfiltration routes—all without leaving the road. In addition to providing this information to the sustainment brigade S–2, convoys can augment the maneuver BCT’s intelligence collection plan. In these ways, the sustainment brigade can be established as a producer—not just a consumer—of intelligence.

Leveraging ISR Support for Logistics Convoys

Although logistics convoys inherently are intelligence collectors, they also require external, overhead ISR support to assist in the counter-IED fight. With a little creative thinking, a sustainment brigade S–2 section can leverage ISR in support of logistics convoys.

The best ISR assets to leverage in support of convoy operations are those that can either communicate directly with the convoy on the road or provide near-real-time analysis of route threats to the brigade tactical operations center (TOC). In northern Iraq, this asset came in the form of a nontraditional intelligence asset: attack surveillance aviation. The 3d Sustainment Brigade’s combat sustainment support battalions were successful in requesting and receiving scout weapons teams to fly in support of their convoys. These helicopters made outstanding ISR assets that assisted the



A 3d Sustainment Brigade Soldier analyzes intelligence derived from logistics convoys' debriefs and from information shared among units across the battlespace.

convoy in identifying IED emplacers and triggermen and also used their arsenals to respond to possible IEDs and troops-in-contact.

While the 3d Sustainment Brigade S-2 aggressively pursued direct support ISR coverage for its convoys and often received assets for its hotspots and operational moves, the brigade was not always the top priority for corps, division, or BCT collection assets. In these instances, convoys took advantage of peripheral coverage on their routes.

For example, even when the 3d Sustainment Brigade was not the supported unit, the brigade S-2 section continuously monitored the unmanned aerial vehicle (UAV) video downlink in the brigade TOC and communicated with analysts in relevant chat rooms to ensure that convoys were aware of threats that the UAV had identified on their routes. The brigade also coordinated for battlespace assets, including sniper teams, to provide additional coverage in IED hotspots on convoy routes. In instances when direct ISR asset-to-convoy communication was

unavailable, the brigade TOC radio and telephone operator would use Blue Force Tracker to immediately notify the convoy of the location of the identified threats.

Synchronization With Enablers

The sustainment brigade S-2 section functions primarily as a fusion cell. Understanding the routes that logistics convoys travel and the battlespace they transit is critical to facilitating the brigade commander's decisionmaking process. Establishing dialog and credibility with maneuver S-2s, as well as with critical enablers like EOD and route clearance teams, greatly assists the sustainment brigade S-2 in compiling a more complete, better-informed assessment.

The best way to facilitate dialog is by establishing a push-pull relationship based on information sharing and trust. For example, S-2s should share the intelligence that logistics convoys provide about the far reaches of the battlespace owner's area of operations. They should inform the route clearance S-2s about

the tactics, techniques, and procedures of logistics convoys so they can better conduct assessments. The sustainment brigade S-2 section should be established as a contributor of intelligence and insight, and forums should be created for critical players to synchronize their information. The 3d Sustainment Brigade hosted or participated in several of these weekly sessions, each with a different focus. Some of the most significant were the brigade counter-IED working group, the forward operating base S-2 meeting, and the Iraqi Army G-2 meeting.

Nurturing relationships with fellow S-2s by providing as much support as possible is also an important part of being synchronized with enablers. As a component of this, the 3d Sustainment Brigade S-2 section adopted four military training teams (MiTTs) located across northern Iraq and provided them with intelligence and security support. In exchange, these MiTTs provided the S-2 with intelligence about the rural areas that logistics convoys transited almost daily.

To extend the reach of all of the units involved, the 3d Sustainment Brigade S-2 gathered detailed intelligence on out-of-sector missions from other sustainment brigade S-2 sections across Iraq and, in return, provided them with route assessments for their missions into the 3d Sustainment Brigade's area of operations. The 3d Sustainment Brigade S-2 also provided security support to local civilian agencies. This further broadened its scope.

Another way the 3d Sustainment Brigade S-2 leveraged critical enablers was by participating in intelligence synchronization working groups with the G-2s of the 25th Infantry Division, the 1st Armored Division, and the 316th Expeditionary Sustainment Command. These weekly sessions not only gave the division G-2s and BCT S-2s a chance to present their focus areas but also provided an opportunity for the 3d Sustainment Brigade S-2 to raise concerns to the highest levels about enemy activity on supply routes, pass on logistics intelligence, and share collection management assets. Among the most beneficial results of these intelligence synchronization working groups were additional ISR support for logistics convoys, targeted battlespace operations focused on 3d Sustainment Brigade hot spots, and improved coordination between logistics and maneuver intelligence sections.

Providing Area-Specific Intelligence

Each 3d Sustainment Brigade logistics convoy covered routes with vastly different threat characteristics. Understanding the routes' demographics, attack trends, and terrain analysis on the microlevel enabled convoys to discover more IEDs than ever before. Soldiers clearly understood where history, nature, and intelligence

analysis dictated that IEDs would be emplaced on their routes. They also received the latest threat updates and information on emerging enemy tactics.

The 3d Sustainment Brigade's convoy readiness center was the locus for intelligence dissemination to convoys. Before heading out on a mission, the convoy commander would verbally walk his Soldiers down the route they were about to travel and brief the convoy on the latest intelligence prepared by the combat sustainment support battalion's S-2. Making the convoy commander the intelligence briefer empowered him to "own" the intelligence and ensured that he was fully aware of the threat situation. The convoy readiness center intelligence brief was area-specific. Each Soldier understood that the threat could be very different 50 miles down the road. This understanding helped ensure that logistics convoys did not become unnecessarily aggressive in friendly areas but still maintained their defensive posture in high threat zones.

Engaging the Nonlethal Fight

Because the sustainment brigade's primary mission is not to kill or capture the enemy, the S-2 must take a nontraditional approach to shaping the battlefield, such as conducting regular nonlethal targeting meetings with battlespace owners and making specific recommendations for humanitarian efforts and economic support. The targeting conducted by the sustainment brigade S-2 is based far more on attack trends and atmospheric conditions than it is on high-value targets. Developing long-term relationships with villages in areas that formerly facilitated insurgent activity proved to be helpful not only in mitigating attacks against logistics convoys but also in underscoring the importance of the mission of 3d Sustainment Brigade Soldiers in Iraq.

Logistics convoys are intelligence-gathering assets, but they are not one of the usual tools military intelligence Soldiers learn about in the schoolhouse. Logistics intelligence requires a little bit of creative thinking, a lot of team building, and plenty of willingness to take a nontraditional approach to solving targeting and ISR-resourcing problem sets. The sustainment brigade S-2 is successful when the brigade's Soldiers make it home and logistics convoys have been acknowledged as producers—not just consumers—of intelligence. **ALOG**

CAPTAIN JENNIFER HURRLE IS THE 3D SUSTAINMENT BRIGADE S-2. SHE HOLDS A B.A. DEGREE IN ENGLISH FROM THE UNIVERSITY OF MICHIGAN AND AN M.S. DEGREE IN STRATEGIC INTELLIGENCE FROM THE AMERICAN MILITARY UNIVERSITY. SHE IS A GRADUATE OF THE AIR DEFENSE ARTILLERY OFFICER BASIC COURSE AND THE MILITARY INTELLIGENCE CAPTAINS CAREER COURSE.



Distribution Operations in MND–North

BY MAJOR CHARLIE WARD

In May 2007, the 3d Sustainment Brigade from Fort Stewart, Georgia, deployed to Operation Iraqi Freedom 07–09 to provide logistics support to Multi-National Division-North (MND–N). The brigade had just completed its transformation to a modular structure before the deployment. The brigade’s support operations office experienced changes under the transformation, including the conversion of the movement control office into a mobility branch and the formation of a new distribution integration branch. This article highlights the distribution integration branch’s mission, explains why the branch was successful, and looks at possible ways to increase effectiveness by reorganizing the branch and the current functions in the support operations office.

The Distribution Integration Branch Mission

The distribution integration branch was responsible for managing the flow of commodities throughout MND–N and had two primary tasks. The first was to manage the throughput of foreign national convoys at Habur Gate—the point of entry for nearly 70 percent of all supplies for MND–N—and Contingency Operating Bases (COBs) Marez, Qayyarah-West (Q-West), and Speicher. The second was to coordinate and synchronize the movement of equipment and other supplies within MND–N.

The focus of the distribution integration branch was to reduce the time it took for the right supplies to travel from their points of origin to their destinations. For

MND–N, the sources of those supplies included seaports, fuel refineries, and food distribution warehouses. The destinations included COBs, forward operating bases, patrol bases, and combat outposts throughout northern Iraq. With so many supported organizations and locations, the distribution integration branch realized the need for a formal process to unify subordinate units and commodity managers in an effort to synchronize distribution operations. This process became the distribution management board (DMB).

When the 3d Sustainment Brigade assumed responsibility for logistics operations in MND–N, the average daily backlog of foreign national sustainment trucks was about 520. These trucks drove through Habur Gate to deliver class IIIB (bulk petroleum, oils, and lubricants), class I (subsistence), and various multiclass commodities. COB Q-West received a daily average of 400 foreign national sustainment trucks, and COB Speicher received a daily average of 385 trucks. In addition to sustainment vehicle backlogs, the brigade had 247 open transportation movement requests (TMRs), with 82 of those TMRs past the required delivery date (RDD). However, the distribution integration branch’s biggest challenge rested with the central receiving and shipping points (CRSPs), which were where cargo from the tactical trucks was downloaded and staged for pick-up. At Q-West, the CRSP yard processed a daily average of nearly 500 containers, many of which had been in the yard for 6 months. In all, over 830 containers were spread across 3 CRSP yards in MND–N.

The Habur Gate staging yard was sparsely populated in February 2008, which was just 5 months after the 3d Sustainment Brigade began efforts to reduce foreign national truck wait time from 8 days to 24 hours.



Foreign National Truck Backlog in MND-N

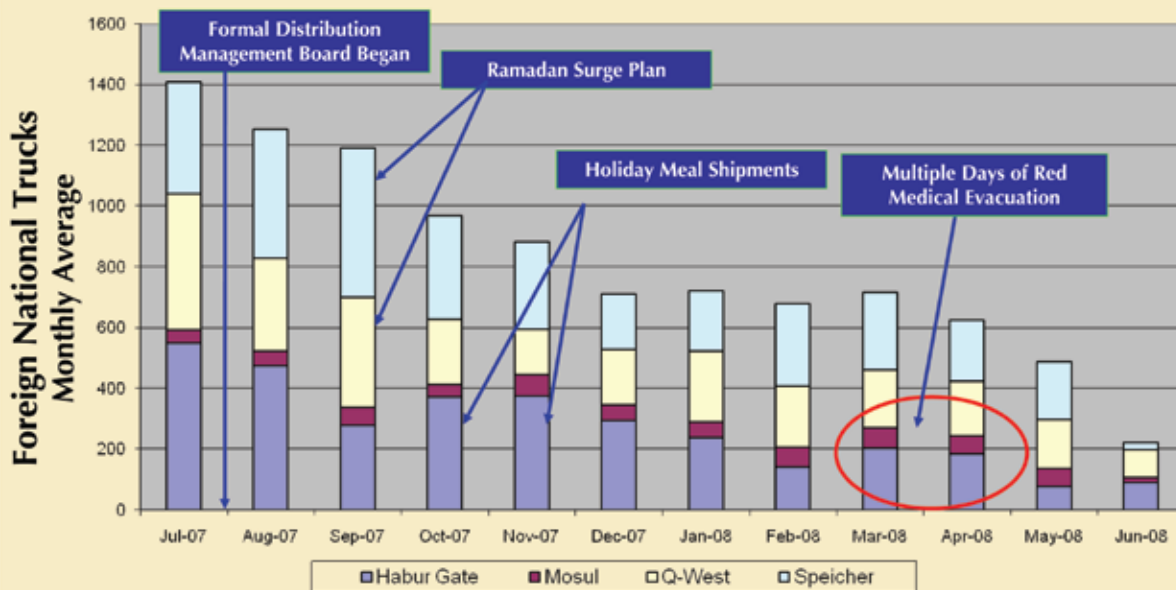

- Reduced backlog by 84 percent from an average of 1,410 to 223 trucks per month.
- Reduced average wait time at Habur Gate from 8 days to 24 hours.

This chart shows the reduction over time in the monthly average of foreign national sustainment trucks managed in Multi-National Division-North.

Convoy Support Center Yard Management

Within the first 4 months of the deployment, the distribution integration branch, working in conjunction with the 3d Sustainment Brigade's subordinate combat sustainment support battalions (CSSBs), was able to reduce the daily average of foreign national trucks in the convoy support center (CSC) yards (the staging area for the foreign national drivers) by nearly 32 percent. The first step to achieving this reduction was to institute the queue-processing technique known as "first in, first out" to reduce and stabilize the number of foreign national trucks that had been in the yards for over 120 hours. Approximately 600 of the 1,410 foreign national sustainment trucks in MND-N had been in a single CSC yard for more than 120 hours. Once the backlog was reduced, the branch prioritized commodity shipments based on need and demand instead of time spent in the CSC yards. The chart above shows the reduction over time in the monthly average of foreign national sustainment trucks managed in MND-N.

In anticipation of the Ramadan holiday period, when little or no ground movement would occur, the distribution integration branch developed a Ramadan surge plan in September 2007. The plan mitigated the spikes of foreign national vehicle traffic by holding the vehicles in the CSC yards. Other known events, like the delivery

of Thanksgiving and holiday meals, had minimal impact on CSC yard congestion because the branch addressed the problem early. Events like weather and enemy activity could not be specifically planned for, but once again, early mitigation made such events inconsequential.

TMR Management

Of the 82 TMRs that were past RDD on arrival, 26 were more than 20 days past RDD and approximately 30 TMRs were between 5 and 19 days past RDD. By January 2008, the brigade was managing 171 open TMRs, with only 2 over 10 days past RDD and 6 that were between 5 and 10 days past RDD.

The distribution integration and transportation operations branches shifted an existing paradigm governing the use of foreign national vehicles and KBR and military flatbeds. Generally, between COB Q-West and COB Speicher in particular, foreign national convoys were separate from other line-haul convoys. Once the brigade was able to reduce the backlog of foreign national vehicles, the distribution integration and transportation operations branches incorporated KBR flatbeds, military flatbeds, and heavy equipment transporters (HETs) into the convoys to allow for the delivery of the oldest TMRs or the TMRs that had a high priority for delivery. The conglomeration of KBR, military, and foreign national



Soldiers load an M109 Paladin onto an M1000 trailer as part of the redeployment of the 4th Brigade Combat Team, 1st Cavalry Division. Redeployment operations of this magnitude would not have been possible without the continuous management of sustainment operations in Multi-National Division-North.

Q-West had the largest bottleneck, which was caused by insufficient CPP capabilities for moving commodities south. The distribution integration branch quickly realized there was a need to cooperate with the transportation operations branch and all subordinate CSSBs and address each battalion's current taskings on a daily basis.

The mechanism for coordination was the DMB, a daily coordination and synchronization planning group. The DMB, which acted as both a synchronization meeting and an asset allocation board, was conducted through Adobe Breeze, a web-based conferencing program that allows subordinate and supported units to participate from remote locations. The DMB allowed the distribution integration branch to forecast asset availability and eliminate bottlenecks.

During the DMB, subordinate CSSBs were given transportation and escort tasks based on the current and forecasted availability of transportation and CPP assets. Supported units in MND-N could also monitor the DMB to address their transportation and distribution requirements. The DMB allowed the brigade and the battalions to forecast movement requirements 120 hours out, to plan 96 hours out, to allocate transportation assets 72 hours out, and to lock in requirements 48 hours before execution.

Establishing multifunctional battalions. Another key factor in reducing the backlogs of TMRs and sustainment commodities was the establishment of truly multifunctional CSSBs at each of the three major hubs. When the 3d Sustainment Brigade arrived in theater, line-haul assets and CPPs were divided between the CSSBs at two COBs. The CSSB located at COB Q-West was resourced with military and KBR line-haul assets. The CSSB located at COB Speicher was responsible for the HETs and a smaller portion of KBR flatbed assets.

The geographic location of these two units made it difficult to use specific line-haul assets efficiently. For example, when a supported unit located outside of COB Speicher required HET assets, the 927th CSSB, which was allocating HETs, would have to "dead head," or travel empty, at times in excess of 240 miles, to the load location. This scenario needlessly put Soldiers on the road and cost the sustainment brigade at least 4 days of mission time. By cross-leveling HET assets to COB Q-West, the 3d Sustainment Brigade was able

vehicles drove the route between COB Q-West and COB Speicher, one of the primary distribution routes for sustainment from Turkey.

CRSP Yard Management

One of the distribution integration branch's most significant accomplishments was clearing the CRSP yards. The CRSP yards saw an astounding 90-percent reduction in containers; the number of containers came down from a daily average of 832 to just over 90. How did the distribution integration branch accomplish this?

First, the distribution integration branch worked tirelessly with the subordinate CSSBs in an effort to understand the reporting procedures, verify accuracy of the reports, and determine a systematic method for capturing other relevant data. Then, along with the CSSBs, the branch determined an efficient and practical means of putting the aged commodities on the road and in the air for delivery using various data sources, including TMR reports, asset utilization reports, and CSC and CRSP yard reports that identified the age, type, and amount of cargo in the yard.

Keys to Success

The distribution integration branch was successful because of a few key initiatives, including the creation of the DMB, the establishment of multifunctional battalions, and the readjustment of the foreign national vehicle to convoy protection platform (CPP) ratio.

Creating the DMB. To identify a process to eliminate the bottlenecks within the supply chain, the distribution integration branch looked at the specific transportation configurations of the CSSBs, including the availability of line-haul assets and CPPs. When delivering assets to the CSSBs, the foreign national sustainment convoys were required to include CPPs for security. COB

to take advantage of HET assets and drastically reduce the need to reposition empty assets.

Readjusting the foreign national vehicle to CPP ratio. The distribution integration branch analyzed the ratio of CPPs to foreign national sustainment trucks at the various COBs. The ratio on the route from Habur Gate south to Marez and Q-West was larger than the ratio from Q-West to the south. The ratio imbalance caused a serious bottleneck at Q-West for onward movement of foreign national vehicles south out of Q-West. The branch first developed a simple algorithm to determine an appropriate ratio of CPPs to foreign national vehicles for southbound movements from Q-West. The algorithm was based on daily inbound foreign national vehicles and the current threat to logistics convoys south of Q-West.

The distribution integration branch determined a feasible ratio that could be supported, cleared the bottlenecks, and moved cargo in a timely and efficient manner. The 3d Sustainment Brigade then drew up a recommendation to the 316th Expeditionary Support Command to adjust the CPP ratio. In 4 months, the distribution integration branch reduced the CSC backlog of foreign national vehicles at Habur Gate, Q-West, and Speicher by nearly 42 percent. With the backlog reduction, the 3d Sustainment Brigade was able to dedicate more CPPs to the movement of TMRs and spearhead the deployment and redeployment of the 3d Armored Cavalry Regiment and the 4th Brigade Combat Team, 1st Cavalry Division, from MND-N.

Possible Improvements

The distribution integration branch and the mobility branch are described in Field Manual Interim (FMI) 4-93.2, The Sustainment Brigade, as separate sections under the control of the support operations officer. Each of these sections has a major assigned as the officer in charge (OIC).

Based on the 3d Sustainment Brigade's current support mission, the functions of these two sections overlap. The 3d Sustainment Brigade's mobility branch currently uses the Battle Command Sustainment Support System, the Transportation Coordinators' Automated Information for Movements System, and the Movement Tracking System to plan and execute missions with the distribution integration branch and to prioritize specific commodity management and missions. However, FMI 4-93.2 states that these functions are the responsibility of the distribution integration branch. Based on the current staffing structure for the 3d Sustainment Brigade, the mobility branch is best postured to execute this mission.

The difference between the two sections is slight. In many cases, the distribution integration branch and the mobility branch perform each other's functions. For

example, FMI 4-93.2 states that the mobility branch, in conjunction with the distribution integration branch, is responsible for deployment planning, movement, sustainment, reconstitution, and redeployment. In the 3d Sustainment Brigade, these tasks are entirely the responsibility of the distribution integration branch. Again, based on staffing, a task shift to the distribution integration branch could be a viable option.

Since the distribution integration branch and the mobility branch have similar requirements and rely heavily on each other, these sections could quite easily be combined under one major-grade OIC. The distribution integration operations OIC would be in a better position to plan and monitor the execution of distribution operations if the OIC were directly responsible for validating and managing the requirements for surface movement. The integration of the mobility branch under the distribution integration branch would provide a one-stop shop for the subordinate CSSBs and the sustainment brigade's supply and services branch to coordinate the distribution of classes I, II (individual clothing and equipment), III, and IV (construction and barrier materials).

The success of the 3d Sustainment Brigade's Operation Iraqi Freedom rotation was first and foremost attributable to its Soldiers. The Soldiers fully understood that modularity would bring challenges and changes. The ability of the support operations office personnel to work together to meet the requirements proved to be the unit's greatest achievement. This achievement was coupled with the close relationships developed with the battlespace owners, the MND-N G-4, and the 316th Expeditionary Support Command. The open lines of communication between the various commands in MND-N ensured a successful rotation for the 3d Sustainment Brigade.

However, many of the accomplishments would not have been possible if not for the hard work executed by the brigade's predecessor, the 45th Sustainment Brigade. As sustainment support in MND-N evolved and matured, the 45th Sustainment Brigade adopted functional and applicable processes within distribution that became the foundation for the 3d Sustainment Brigade's distribution success. By continuing to refine the role and function of the distribution integration branch, the 3d Sustainment Brigade will be postured to fully and professionally support coalition forces anywhere in the world.

ALOG

MAJOR CHARLIE WARD IS THE DEPUTY SUPPORT OPERATIONS OFFICER AND DISTRIBUTION OPERATIONS CHIEF FOR THE 3D SUSTAINMENT BRIGADE, WHICH RECENTLY REDEPLOYED FROM OPERATION IRAQI FREEDOM. HE HAS A MASTER'S DEGREE IN LOGISTICS MANAGEMENT FROM THE AIR FORCE INSTITUTE OF TECHNOLOGY AND IS A GRADUATE OF THE COMBINED LOGISTICS CAPTAINS CAREER COURSE.



Engineers Breaking New Ground in the Sustainment Brigade

BY MAJOR ANNE V. TAYLOR

In June 2006, the 3d Sustainment Brigade began its transition from a division support command (DISCOM) to a sustainment brigade under the new modular concept. With this transition, the sustainment brigade gained an engineer element that was not available in the DISCOM. As the brigade engineer, I fell under the support operations section and was colocated with the plans cell.

In preparation for the 3d Sustainment Brigade's deployment, the brigade commander decided to change the composition of the engineer section in anticipation of its role during the deployment. The first change made the engineer a separate S-staff, designated as the S-7, aligned with division and corps engineer cells. The second change was to add several personnel to the cell. For the first 10 months of the deployment, the

Soldiers disassemble an assault float bridge. The boats along the side will be used to push the bridge section once it is disconnected.



Modular transformation added a new element to the 3d Sustainment Brigade: An engineer section.

cell had an engineer major and a lieutenant; for the last 5 months, the cell was also assigned two noncommissioned officers.

3d Sustainment Brigade Engineer Functions

Most Army branches are categorized as being operations support; maneuver, fires, and effects; or force sustainment, but engineers have mission sets within each of these categories, particularly in areas such as mobility assurance and construction. Operations support engineers advise the maneuver commanders on the effective use of terrain, construction efforts, and the improvement and maintenance of routes, bridges, and airfields.



However, the 3d Sustainment Brigade did not own any engineer assets, so all requirements for engineer support were coordinated through engineer brigades, division engineers, or corps engineers. The sustainment brigade engineer's primary responsibility during the deployment was coordinating for the maneuver enhancement function with engineers of combat heavy battalions and bridge companies.

An engineer in a sustainment brigade has two main missions: assured mobility and construction project management.

Assured Mobility

Mobility is the ability of military forces to move in time and space while retaining the ability to fulfill their primary mission. Assured mobility is a relatively new doctrinal term. The imperatives and fundamentals of assured mobility enable friendly forces to exploit superior situational understanding and therefore gain unsurpassed freedom of movement. Assured mobility is vital to the success of convoys that operate on some of the most dangerous supply routes in Iraq. It involves coordinating with route-clearance assets, air weapons teams, and intelligence, surveillance, and reconnaissance assets. Being able to synchronize convoy schedules with these assets ensures the safety and security of our troops.

Not only did the 3d Sustainment Brigade serve as the brigade in charge of sustainment operations in Multi-National Division-North (MND-N), it was also responsible for mayoral duties on Contingency Operating Base (COB) Qayyarah-West (Q-West). As such, the brigade engineer, in conjunction with the Logistics Civilian Augmentation Program contractor, the facilities engineer team, and the battalion-level mayor's cell, provided oversight of all construction initiatives on the base.

The 3d Sustainment Brigade transported supplies and commodities in long convoys that traversed main and alternate supply routes daily. An immediate challenge to our freedom of movement was the emplacement of improvised explosive devices (IEDs) in culverts. This particular enemy tactic was one of the more effective attacks on our logistics convoys because a deeply buried IED could potentially result in an underbelly attack with catastrophic results. This type of attack was of particular concern because over 1,500 culverts in MND-N were vulnerable to such enemy exploitation.

Addressing Culvert Threats

In July 2007, shortly after the 3d Sustainment Brigade took the reins from the 45th Sustainment

Brigade, an IED blew up a large culvert on an alternate supply route that the sustainment brigade frequently used. This experience highlighted the importance of linking sustainment with the engineers. For this particular situation, the affected unit reported the incident and gave an initial serious incident report. The sustainment brigade engineer then coordinated with the engineer brigade, which assigned one of its subordinate companies to repair the damaged culvert. The engineer company deployed to the site to assess the battle damage and determine if it could create a bypass sufficient to accommodate logistics convoys. The company then allocated the resources needed for repair and established a timeline and completion date for the repairs. This experience gave me the insight that I needed for future assured mobility issues.

As soon as a significant mobility issue arose, the sustainment brigade engineer would call the engineer battalion to alert it of the impending serious incident report. From this, the sustainment brigade engineer learned that giving the engineer battalion specific information, such as the impact on impending missions, enhanced its situational awareness and aided it in prioritizing the mission among the various demands on its assets. Engineer support is generally

limited to one engineer battalion that can respond to mobility issues in an area of operations, making such prioritization essential.

By contacting the engineers directly, the brigade engineer also established points of contact for working on future assured mobility issues and receiving crucial updates and even photos of the battle damage. Taking this approach allowed the sustainment brigade engineer to give the commander and affected subordinate units instant feedback, which enabled the commander to visualize the damage, determine the impact on the mission, and decide on a course of action.

To deal with the colossal number of culverts and reduce the threat, the engineers accelerated the effort to make all culverts unusable for IEDs, starting with the main supply route and eventually branching out to the alternate supply routes. Various methods were used; however, the most effective method was to weld steel grates onto the culverts. This not only denied the enemy's access to the culvert but also left the culvert functional. Although these methods of denial were highly successful, the enemy still tried to breach the denied culverts in an attempt to place IEDs.

The enemy's attempts to breach the denied culverts resulted in an important lesson learned. Given the limited number of engineer assets in theater, the application of assured mobility was performed by all branches, not just engineers. Logistics convoys traveling on the main and alternate supply routes detected the attempted breaches, documented the grids, took photos of the tampered-with culverts, and passed this information to the S-7. The S-7 immediately sent this information to the engineer brigade and started coordination for reconnaissance and repair. The S-7 also documented the incident, started a brigade tracker for all mobility issues, and immediately sent the information to all subordinate battalions.

As with the culverts, IEDs placed in previous blast craters were particularly problematic for logistics convoys. MND-N had hundreds of craters that added to the psychological effect on our Soldiers. The enemy would also bury large amounts of homemade explosives by digging on the side of the road, placing the material just underneath the pavement, and then back-filling with the same dirt to make the area seem innocuous. The enemy also marked the craters to make them appear as if they were marked by coalition forces. The difference was that our logistics convoys had become savvy enough to know what to look for. All suspicious craters were promptly documented, photographed, and reported to the S-7 for action.

An engineer guides concrete into a crater that has been prepared for filling.



The Engineer Daily

As additional mobility issues began pouring in, and after receiving numerous emails requesting information on mobility issues affecting the brigade, the S-7 decided to create the “Engineer Daily.” The Engineer Daily addressed all engineer issues affecting the brigade, such as route clearance schedules and missions, engineer construction at various contingency operating bases, airfield information, route status, culvert and crater repair missions, route sanitation missions, bridging information, and any other mobility issues affecting the brigade. As more units became aware of what engineers brought to the fight, the S-7 began to receive requests from subordinate units for engineer support, which the section coordinated through the engineer brigade.

The Importance of Points of Contact

In addition to the challenges posed by the numerous culverts and craters, we were also faced with the daily threat of attacks. We encountered hundreds of attacks during our rotation. This unfortunate situation would provide the section with yet another crucial lesson learned—the importance of establishing good points of contact and having open and honest dialog with the engineers. During a crisis is not the optimal time to establish contacts. When relationships are already established, problems tend to get solved more quickly because the engineers are more familiar with unit requirements.

Continuous attacks on our logistics convoys caused the S-7 to become intimately familiar with both route clearance engineers and explosive ordnance disposal personnel. To help mitigate the daily attacks on our logistics convoys, the route clearance engineers and the S-7 worked closely to coordinate route sanitation to complement convoy movements. Explosive ordnance disposal and route clearance representatives became permanent fixtures at sustainment brigade meetings and provided invaluable input.

Route Clearance

The S-7’s first experience in coordinating with the engineer brigade for route clearance was brought on by an IED concealed in bushes in the median. This experience demonstrated the importance of synchronizing route clearance. The S-7 coordinated with the engineer brigade to have some shrubs and trees removed from the area. This was a somewhat tricky venture because we wanted to use a technique that would not allow the shrubs to return easily. Burning was considered but rejected because some locals felt that we were destroying the beauty of their country. Other techniques were tried to remove not only the shrub but also the roots. We ultimately succeeded by using a bucket loader. The lesson learned from this



Engineers finish filling a crater in a road.

experience was to be proactive and aggressive in getting issues of this type to the engineers.

Construction Project Management

Compared to the section’s assured mobility challenges, construction projects were uneventful. The heavy construction engineers were stretched thin as they built life support areas at combat outposts, erected traffic control points, conducted major runway repairs, and surrounded the entire city of Mosul with a berm that forced traffic into the traffic control points. The heavy construction engineer section’s primary responsibility was to coordinate vertical support with the construction assets for units at Q-West. The major projects that the section coordinated included the new brigade tactical operations center, passenger terminal, and troop medical clinic. As for the traffic control points and berming operations, the section’s task was to alert units that the engineers would be working in those areas and let them know how the work would affect operations. This was particularly important for the airfield because the runway was closed during repairs. The key lesson learned from the engineer’s construction projects was to get on the engineer brigade’s distribution list to receive their construction schedule. The S-7 simply inserted the slides received



An M60A1 armored vehicle launched bridge carries a bridge to the location where it will be installed.

from the engineer brigade into the Engineer Daily and sent them to our subordinate units and roughly 100 other individuals who requested to be put on the S-7's distribution list for synchronization purposes.

Bridging

Although the section's experiences with construction were relatively uneventful, its challenges with military bridging were anything but. Engineers are doctrinally responsible for gap crossing. The primary technique used for gap crossing was normally one of four types of bridging: armored vehicle launched bridge, dry support bridge, assault float bridge, or the Maybe Johnson bridge. In total, insurgents blew up five bridges in the 3d Sustainment Brigade area of operations: Alqwair Bridge, Taji Bridge, Mosul Dam Bridge, Badoush Bridge, and Qayyarah Bridge, which was closest to home and had the most profound effect on the brigade. All of these bridges were successfully attacked twice within a relatively short timespan. After the second attack on the Taji Bridge, military bridging was emplaced at the Mosul Dam, Badoush, and Qayyarah bridges.

The engineer section gained most of its experience and lessons learned while coordinating for bridge support for Qayyarah Bridge. Following the Qayyarah Bridge explosion, the brigade was immediately cut off from an alternate supply route, which forced it to either delay or cancel logistics convoys. The primary staff did extensive mission analysis and worked well into the night to determine a course of action sufficient to ensure continued support to outlying forward operating bases. The S-7 was center stage as the section fielded wave after wave of questions concerning the capabilities of military bridging and other bridge-related questions. Most of the staff had never seen or heard of the kinds of bridges that were being proposed. Once again, the S-7 relied heavily on the engineer brigade to provide information concerning the pending battle damage assessment, the extent of the damage, and an estimated

timeline for repairs, all of which would factor into the mission analysis to determine a course of action.

The Qayyarah Bridge was eventually over-bridged with a dry support bridge and later replaced with an assault float bridge. The assault float bridge is a tactical bridge with a low silhouette that is not necessarily designed to remain in place for a long time. The Qayyarah assault float bridge was open to both military and civilian traffic. The bridge went down for repairs at least once a month because of conditions such as low water level, vehicles hitting the bridge, or extensive flooding. The average time for repairs was about 2 to 3 days. Perhaps the biggest challenge the bridge presented occurred in March, when the river flooded after several days of continuous rain. Most of the bridge's interior bays sank just below the surface of the water. Although this brought military traffic to a standstill, it did not deter the locals from wading across on foot.

The Future for Engineers in Sustainment Brigades

Undoubtedly, the most critical mission for an engineer in a sustainment brigade is coordinating assured mobility assets. The ability to synchronize the movement of logistics convoys throughout the area of operations was vital to the success of the mission and the safety of our troops. An engineer must know the location of every bridge, culvert, and crater within his sustainment brigade's movement area because each presents a significant vulnerability to mobility. Just as important is the relationship between the sustainment brigade engineer cell and the division- and corps-level engineer assets. The sustainment brigade engineer must know who to call and coordinate with for various assets, such as route clearance; intelligence, surveillance, and reconnaissance support; and crater and road repair.

The 3d Sustainment Brigade had never had an engineer officer assigned; the engineer section was in uncharted waters with no template to serve as a guide. It faced many engineer challenges in construction and assured mobility during the 15-month rotation and managed to come through undaunted. The engineer section learned many invaluable lessons during the deployment and, if it is called on again, those experiences will undoubtedly serve the section members well.

ALOG

MAJOR ANNE V. TAYLOR IS THE BRIGADE ENGINEER FOR THE 3D SUSTAINMENT BRIGADE. SHE HOLDS A B.S. DEGREE IN EDUCATION FROM TEXAS SOUTHERN UNIVERSITY AND IS A GRADUATE OF THE ARMY COMMAND AND GENERAL STAFF COLLEGE.



Establishing Modular Human Resources Operations in Iraq

BY CAPTAIN SHAUNAREY AMOS

In order to deploy to Iraq as a fully modular unit, the 3d Sustainment Brigade had to transform its human resources operations to make them modular as well. This represented a significant change in its human resources operational structure and procedures.

The concept of modular human resources operations was introduced to the 3d Sustainment Brigade in the summer of 2006 before it deployed in support of Operation Iraqi Freedom (OIF) 07–09. Changes in human resources support resulting from personnel services delivery redesign and transformation to modularity made the creation of the human resources operations cell in the sustainment brigade a key element in integrating postal, casualty liaison, and aerial passenger accountability operations. Predeployment training, preparation, and education at all levels proved critical in integrating the human resources operations cell into the logistics environment for OIF 07–09.

The Human Resources Combat Organization

Field Manual (FM) 1–0, Human Resources Support, states that the human resources company can be task-organized to either the brigade special troops battalion (STB) or the combat sustainment support battalion (CSSB) for command and control. The 3d Sustainment Brigade chose to task-organize the company under the STB because the 3d STB shared a similar command relationship with the 24th Finance Company in garrison at Fort Stewart, Georgia. The 3d STB took steps to form a relationship with the 101st Human Resources Company (organic to the 101st Sustainment Brigade) from Fort Campbell, Kentucky, in an effort to build a mutual understanding of operations and form the bond of a command relationship before deploying.

FM 1–0 also states that the human resources operations cell within the brigade support operations office (SPO) is to provide direct technical oversight to the human resources company that is task-organized to either a CSSB or STB in deployed operations. Although feasible, the technical channels as they were did not reflect the command and control relationships between the company, battalion, and brigade. The human resources company would be attached to the brigade STB for command and control during OIF 07–09. After further analysis, the brigade human

resources operations cell was split between the STB and the brigade SPO to provide human resources technical expertise to both the company and the brigade.

Predeployment Training and Preparation

Since the human resources operations cell was a new element, it was unclear what type of training was needed to make the 3d Sustainment Brigade successful as the first completely modular sustainment brigade with a human resources company in theater. The Human Resources Management Qualification Course at the Adjutant General School at Fort Jackson, South Carolina, was determined to be the best source of individual education on personnel services delivery redesign and modularity. This course gave the human resources cell officer in charge and noncommissioned officer in charge a broad knowledge base of the changes in personnel support in a brigade-centric Army. The course provided insight into casualty reporting using the Defense Casualty Information Processing System and into maintaining personnel accountability using the Defense Theater Accountability System.

Attending the Postal Operations and Postal Supervisor Courses was also deemed necessary because of the high level of technical expertise required to oversee all levels of postal operations in theater. This education and the level of experience within the section led to a solid technical foundation for the first sustainment brigade human resources operations cell.

Collective training for the sustainment brigade had to change to reflect the new support responsibilities down range, which included the integration of human resources operations into training exercises. Changing the collective training proved difficult because of missing key elements and mission sets supported by the casualty liaison teams; reception, rest and recreation, return to duty, replacement, and redeployment (R5) teams; and postal platoons. The local training exercises were not sufficient to provide the human resources operations cell with real-world theater challenges.

Human Resources/Sustainment Relationship

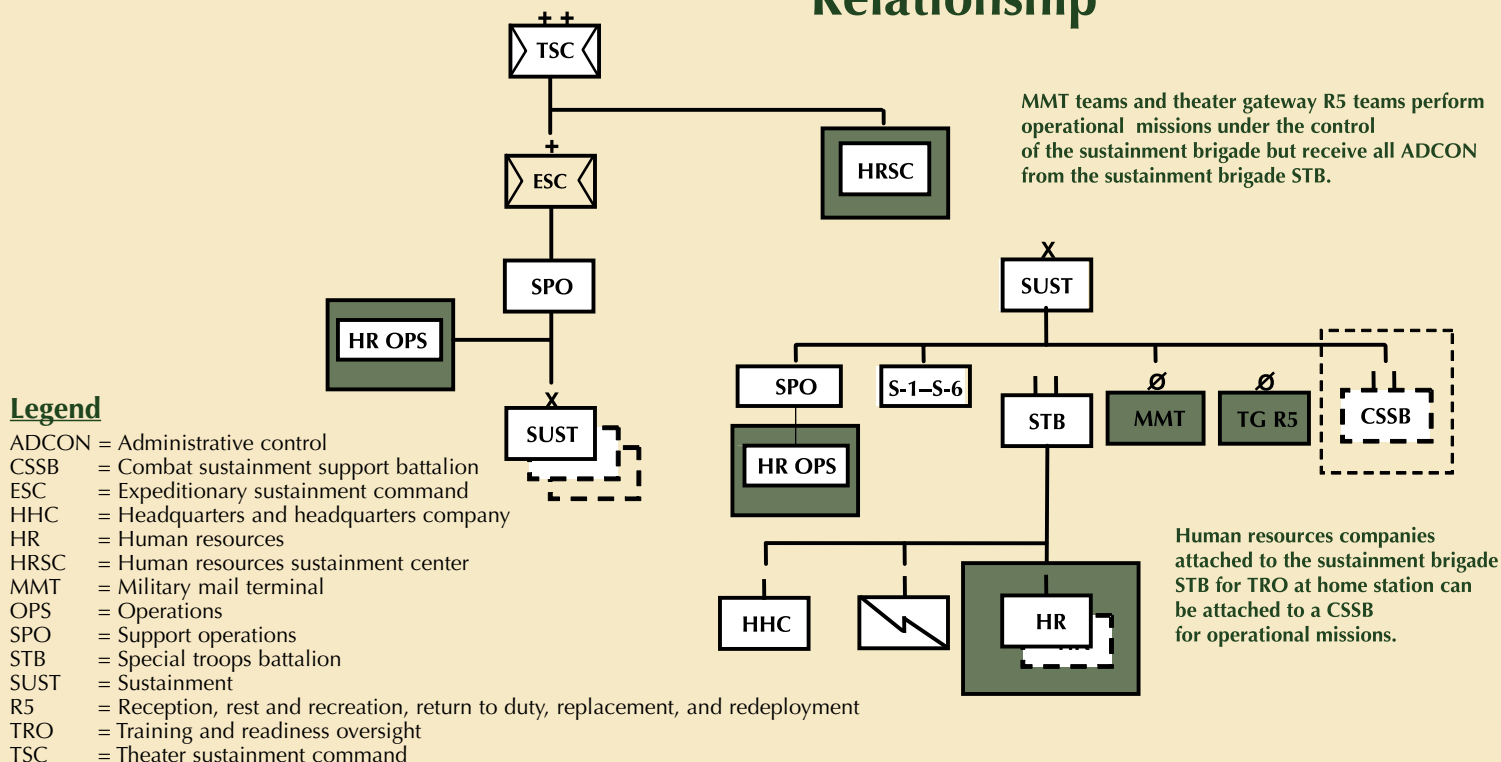

Research within the adjutant general community led to the Silver Scimitar training exercise, hosted by the 3d Personnel Command (now the 3d Human Resources Sustainment Center) at Fort McClellan, Alabama. An annual training exercise for Army Reserve personnel and postal units, Silver Scimitar is a collective training experience for legacy personnel units on postal operations, casualty reporting, and personnel accountability in a simulated deployed environment. In the spring of 2007, legacy personnel battalions converted to modular human resources teams, creating a mixed training environment for Silver Scimitar and fostering an environment for learning the progression from legacy procedures to modular procedures. This experience proved to be beneficial to the 3d Sustainment Brigade's human resources operations cell when it deployed.

Human Resources Operations in Iraq

In Iraq, the sustainment brigade SPO had a strong working relationship with the Multi-National Division-North (MND-N) G-4 based on the support provided to the brigade combat teams and operating bases within that division's area of responsibility. Lines of communication were established between the human resources operations cell and the MND-N G-1 to formally gauge the adequacy of human resources support provided to units throughout the area of operations for casualty reporting, aerial personnel accountability, and Army Post Office services and mail delivery. Modularity

caused a migration of these services from direct support (services to a specific element) to a more general support (services to a specific area) role in theater.

The human resources operations cell served as a liaison between the sustainment community and the human resources company. This relationship easily facilitated the management of human resources support based on the needs of the supported units as units relocated on the battlefield. Open lines of communication with the division G-1 allowed the sustainment brigade to ensure that information was shared in order to continually improve the level of support provided within the shared area of responsibility. This also gave the division a point of contact in order to directly affect or change human resources support as the dynamics of the battlefield changed over time.

Lessons Learned in Theater

As the first completely modular sustainment brigade in theater, the 3d Sustainment Brigade hosted a human resources summit in November 2007 to present lessons learned to the other sustainment brigades and to synchronize this effort with the 316th Expeditionary Sustainment Command and the 8th Human Resources Sustainment Center. By capitalizing on the technical expertise that remained in the personnel services battalion and theater-level input from the 8th Human Resources Sustainment Center, the summit enabled critical discussions about the differences between

doctrine and theater operations. The 3d Sustainment Brigade proposed standardized reporting procedures for the Defense Casualty Information Processing System reports generated by the casualty liaison team, passengers who were processed through the aerial ports of debarkation and embarkation, and postal personnel. These reporting standards were adopted by the 316th ESC as the theater standard for human resources reporting for all sustainment brigades.

A major challenge in theater was the arrival of the human resources company headquarters after all of its teams and platoons had completed their reliefs in place and transfers of authority. The headquarters element should have deployed in advance of its teams and platoons in order to establish the command and control and technical channels and to refine reporting requirements to higher headquarters. A legacy personnel services battalion remained in theater to receive each casualty liaison team, R5 team, postal platoon, and plans and operations section that would be task-organized to the human resources company. However, reporting procedures were already in place and a technical relationship was established without any input from the company commander because the headquarters was the last element to arrive in theater.

Under the modular concept, the 101st Human Resources Company headquarters deployed without its plans and operations section or any of the detachments and teams that it had habitual relationships with at Fort Campbell. Instead, the company, which was made up of detachments and teams from a variety of human resources units from across the continental United States and Europe, fell in on the plans and operations section of the 502nd Human Resources Company.

Training Needs

Deploying to Iraq to form a team out of these dispersed elements that had never trained together presented several challenges. Most notably, neither the 3d Sustainment Brigade STB nor the 101st Human Resources Company could determine the level of training that each team or platoon had received. By contrast, deploying an organic company has the benefits of an established command and control relationship and the team cohesiveness that develops when units train and operate collectively.

Predeployment training, collectively and individually, should be based on the theater common operating picture. Human resources professionals at all levels must become familiar with sustainment brigade support operations, such as understanding how to coordinate transportation for mail movement and the relationships among the movement control team, the Air Force, and the R5 teams in the aerial passenger mission. The human resources cell gained a working

knowledge of these processes during predeployment training exercises, but it did not gain a complete appreciation for all of the agencies involved in conducting successful human resources operations until after they arrived in theater.

Predeployment training should include providing mission oversight to contractors on the battlefield. During OIF 07–09, the missions of six Army Post Offices in the 3d Sustainment Brigade area of support were partially transferred to KBR under the Logistics Civilian Augmentation Program contract. In order to provide continuous oversight, human resources personnel had to be trained on the roles and limitations of contractors in the workplace and certified in contract oversight. Contracting officer's representative (COR) training was not a part of the predeployment training validation. This certification was available in theater; however, the CORs involved in human resources functions such as postal operations should obtain this training well before arriving in the area of operations. Education on the management of contractors should be incorporated into the predeployment training process in order to provide oversight to this portion of the human resources mission immediately upon arrival into theater. Smooth human resources operations depend on competent CORs.

The 3d Sustainment Brigade officially assumed its mission in June 2007. Within 8 months, human resources support transitioned from a personnel services battalion of over 400 personnel supporting 12 locations in theater to a modular human resources company of just over 200 personnel responsible for the same 12 locations. Army Post Office contracting allowed almost 60 percent of the postal Soldiers to be reassigned in support of other human resources missions in the 3d Sustainment Brigade area of support.

Contracting in other areas of the human resources support mission would further increase the need for CORs within the human resources company and affect the force structure management of future human resources teams in theater. As the mission continues to change in theater, information must be shared in order to understand and integrate realistic human resources operations in the deployment training of the sustainment community.

ALOG

CAPTAIN SHAUNAREY AMOS WAS THE SUPPORT OPERATIONS HUMAN RESOURCES PLANS AND OPERATIONS OFFICER FOR THE 3D SUSTAINMENT BRIGADE, 3D INFANTRY DIVISION, IN OPERATION IRAQI FREEDOM 07–09. SHE HOLDS A B.A. DEGREE IN HISTORY FROM MORRIS COLLEGE AND IS PURSUING AN M.A. DEGREE IN HUMAN RESOURCES MANAGEMENT FROM WEBSTER UNIVERSITY. SHE IS A GRADUATE OF THE ADJUTANT GENERAL OFFICER BASIC COURSE.



Integrating Financial Management Operations in a Logistics Support Environment

BY LIEUTENANT COLONEL RUSSELL A. HOLSCHER

During its deployment to Operation Iraqi Freedom 07–09, the 3d Sustainment Brigade was the first to use to modular financial management operations while in theater.

In May 2007, the 3d Sustainment Brigade deployed to Operation Iraqi Freedom to assume command and control of sustainment operations for the Multi-National Division-North (MND–N) and to complete the transformation of legacy personnel services and finance battalions to modular human resources and financial management companies. Initially, the companies capitalized on the experience of the 125th Finance Battalion and the 22d Personnel Services Battalion to identify staff functions that were specific to the finance and human resources communities. These functions would be consolidated under the brigade's special troops battalion (STB), and the STB staff would assume responsibility for providing command and control of both missions.

On 30 July, the 125th Finance Battalion transformed to become the 82d Financial Management Company (FMCO) under the brigade's STB. With this transition, the 3d Sustainment Brigade became the first sustainment brigade to conduct modular finance operations in theater. On 28 November, the 22d Personnel Services Battalion transferred authority to the 101st Human Resources Company (HRCO), completing the 3d Sustainment Brigade's conversion to the first fully modular sustainment brigade in theater.

Getting Organized

The initial challenge was to provide the STB commander with a staff that had the expertise needed to provide command and control to the FMCO. The brigade staff is authorized only three financial personnel: a resource management officer, a financial operations officer, and a finance noncommissioned officer (NCO). The intent of this structure is for the brigade to provide direct technical guidance and oversight of FMCO operations while the STB commander provides administrative control.

However, the brigade commander's intent was for the STB commander to provide command and control, not just administrative control. To accomplish this, the STB commander pulled one NCO from the FMCO's

operations cell to the battalion staff. This move enabled the battalion to readily interpret finance data and advise the commander on financial operations. It also ensured that the entire chain of command had the expertise needed to make informed decisions involving personnel and the resources required to support the mission.

The next challenge was to integrate FMCO operations with the 316th Sustainment Command (Expeditionary) and the 336th Financial Management Command (FMC) to solidify reporting requirements and the flow of reports in theater. The FMC is responsible for providing theater-level technical oversight of financial operations and coordinating support with national providers such as the Federal Reserve System, the Army Finance Command, and the Defense Finance and Accounting Service. It also reviews theater financial requirements and recommends to the commander of the expeditionary sustainment command (ESC) the appropriate financial detachments and teams to support those requirements. However, the 336th FMC is not in the FMCO's chain of command.

To build a positive relationship and delineate responsibilities, the 3d Sustainment Brigade hosted a financial summit with the 316th ESC and 336th FMC to discuss responsibilities and reporting requirements. During the summit, everyone agreed that technical reports would flow through the sustainment brigade to the FMC with a courtesy copy to the ESC and tactical reports would flow through the sustainment brigade to the ESC. The sustainment brigade commander would execute normal command functions, approve cash-holding authority, and appoint disbursing officers and investigating officers; the FMC would provide the technical expertise to review loss of funds investigations and accounting discrepancies as appropriate. This teamwork approach to the command and technical chains proved highly successful, capitalizing on the experience and capabilities of the FMC director and staff while reinforcing the position of the sustainment brigade commander as the commander for financial operations in MND–N and MND–West.

Reducing U.S. Dollars

Once the command and technical relationships were cemented, the 82d FMCO began developing solutions to the larger challenges in finance operations. The first challenge was to develop a means of reducing the amount of U.S. dollars on the battlefield. This served three purposes. First, reducing cash payments made to contractors lowered the exposure of Soldiers to the risks associated with transporting large amounts of cash. Second, reducing cash on the battlefield reduced illegal activity. Third, it reduced the amount of money available to insurgent groups to fund operations against coalition forces.

The theater's first effort to reduce cash on the battlefield was the introduction of the Eagle Cash Card. [The Eagle Cash Card is a stored-value card that can interface with automated kiosk devices located at camps or bases, allowing enrolled cardholders self-service access to funds in their U.S.-based checking or savings accounts. The cards can be used to purchase items at the exchange or from other concessionaires on base.] This was followed by a new theater disbursing policy limiting the amount of cash disbursed to a Soldier in a month in the form of casual pays, Eagle Cash Card transactions, and check cashing.

Next, the FMCO concentrated on converting contract payments from U.S. dollars to Iraqi dinars. The challenge was twofold: acquiring enough dinars to pay an estimated \$7 million per month to contractors and paying the conversion fees. The 316th ESC and the 336th FMC worked with the local Iraqi banks to obtain enough dinars to support just over 1 month's requirements at a time, and the 1st Theater Support Command negotiated a purchase request and commitment for the conversion fee for 1 month and eventually established a separate line of accounting to pay the fees.

Finally, the FMCO worked with MND-N, 1st Armored Division resource management office, and the 336th FMC to change contracts from cash payments to electronic funds transfers (EFT). The Iraqi banks were not accustomed to EFT payments in large amounts and had set their parameters to reject any EFT payments in excess of \$50,000. We worked through the Federal Reserve System's International Treasury Services to increase the maximum amount to \$10 million per day with a \$200

Finance Conversion

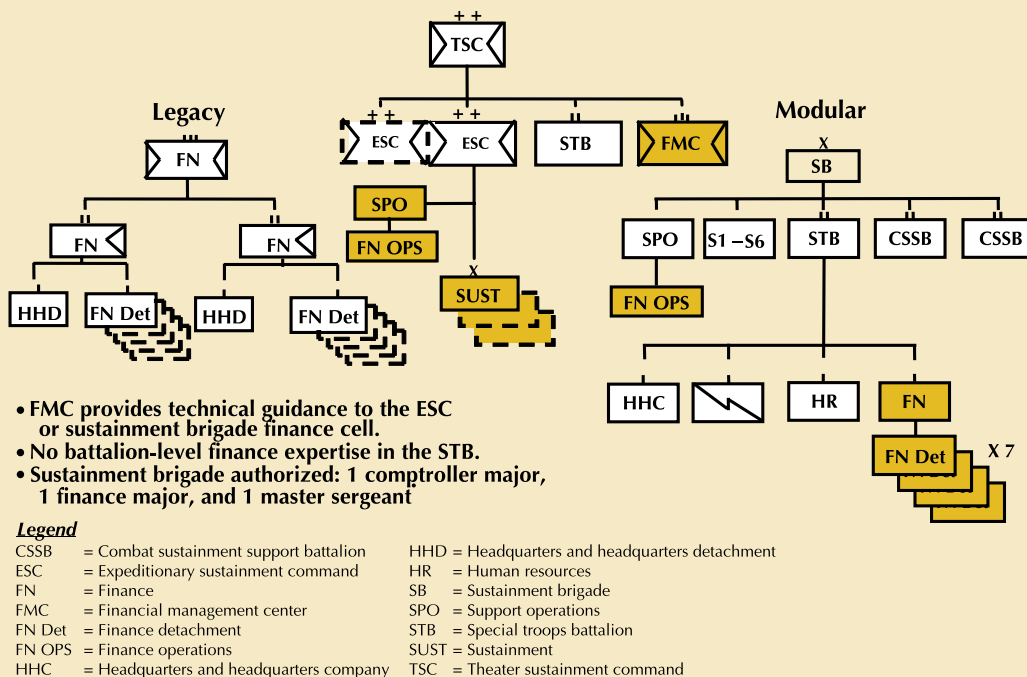

- FMC provides technical guidance to the ESC or sustainment brigade finance cell.
- No battalion-level finance expertise in the STB.
- Sustainment brigade authorized: 1 comptroller major, 1 finance major, and 1 master sergeant

million per month limitation. With this increase, EFT payments increased from \$2.3 million in November 2007 to \$13.8 million in February 2008. The net effect of all of these changes was to reduce the amount of U.S. dollars paid to contractors in Iraq from 48 percent of our total disbursements to 18 percent. This amount continued to decrease as MND-N worked with the FMCO to ensure that all future contracts over \$50,000 would require the contractor to accept EFT payments.

Over the course of its 15-month deployment, the 3d Sustainment Brigade and the 82d FMCO distributed an average of \$40 million per month. The FMCO worked with the 336th FMC and the Federal Reserve System to reduce the amount of U.S. dollars on the battlefield by procuring Iraqi dinars and paying local national contractors an average of \$7 million a month in dinars instead of dollars. The brigade resolved issues with international banking transactions, converting a majority of the larger contracts from cash payments to EFT. The brigade eliminated the use of Treasury checks as a form of payment and provided first-class financial support to the Soldiers assigned to MND-N and MND-West. Although the conversion to full modularity was not an easy endeavor, it was successful and proved that the concept works.

ALOG

LIEUTENANT COLONEL RUSSELL A. HOLSCHER IS THE SUPPORT OPERATIONS OFFICER FOR THE 3D SUSTAINMENT BRIGADE. HE IS A GRADUATE OF THE QUARTERMASTER OFFICER BASIC COURSE, THE COMBINED LOGISTICS OFFICERS ADVANCED COURSE, AND THE ARMY COMMAND AND GENERAL STAFF COLLEGE.



Nonlethal Engagements as a Sustainment Mission

BY CAPTAIN LLOYD E. WARREN III AND CAPTAIN BRITTANY R. WARREN

Successful support of counterinsurgency operations can require logisticians to pursue unorthodox strategies. The 3d Sustainment Brigade learned that cultivating good relationships with local Iraqi leaders and villagers can improve the security of logistics operations in a challenging environment.

The Soldiers of the 3d Sustainment Brigade recognized early during the brigade's deployment in support of Operation Iraqi Freedom (OIF) 07–09 that the mission of sustainment operations within the Multi-National Division-North (MND–N) was an inherently complex undertaking. We soon learned that, in a counterinsurgency environment, logistics units can help maneuver forces to accomplish their missions by conducting humanitarian operations, building and maintaining relationships with local sheiks and Iraqi Army and Police officials, and supporting the local economy. Collectively, these operations are known as “nonlethal engagements,” or NLE.

The 3d Sustainment Brigade operated in a complicated threat environment within MND–N and consistently experienced more enemy activities against its Soldiers and civilians than any other sustainment brigade in theater. It was apparent early on that long-term success in the brigade's area of operations (AO) would require a multidimensional mission set. In addition to traditional sustainment operations, the brigade embraced the MND–N commander's mindset of putting Iraqis in the lead to promote self-reliance, interacting with the local populace to build relationships, creating jobs to stimulate the economy, and bolstering local confidence in Iraqi law enforcement and military officials.

The Brigade's NLE Strategy

Although the 3d Sustainment Brigade did not own any ground during OIF 07–09, its area of influence was spread over 3 major contingency operating bases (COBs), 20 forward operating bases (FOBs), and a web of supply routes that served as the lifelines of MND–N. On a daily basis, the brigade's units conducted logistics patrols across MND–N from Habur Gate to Balad and from Kirkuk to Tal Afar—an area about the size of

Pennsylvania. Unlike the combat units it supported, the 3d Sustainment Brigade did not conduct kinetic operations to kill or capture the enemy. That is not to say that it had no impact on decisively shaping the AO. The brigade's Soldiers came into contact with thousands of Iraqis daily across the AO, which put them in an excellent position to implement a robust NLE strategy that would allow them to influence the AO significantly. In view of its capabilities, the brigade developed and executed an NLE strategy geared toward promoting economic stability, the security of the populace, and Iraqi self-reliance, all in support of the objectives of MND–N and the 316th Sustainment Command (Expeditionary).

Evolution of the Brigade's NLE Program

When the 3d Sustainment Brigade took the reins from the 45th Sustainment Brigade on 26 June 2007, it fell in on a system of humanitarian-type NLEs, such as handing out sundry packets, toys, and school and medical supplies and providing jobs for local Iraqis around COB Qayyarah West (Q-West) through the Department of Public Works (DPW). For the first 90 days of the deployment, this was the strategy that those of us in the brigade used, particularly in the villages around COBs Q-West, Marez, and Speicher. With the shift in



Task Force 113 Soldiers pass out school supplies in Fruga. Supporting local schools was a part of the overall NLE strategy for Qayyarah and its surrounding villages.

theater policy at the end of 2007 toward promoting Iraqi self-reliance, we began a complete overhaul of the existing NLE strategy.

The first step in developing the brigade's NLE strategy was to better align our strategy with the guidance from our higher commands. The stated intent of the Multi-National Corps-Iraq (MNC-I) was for units to identify and engage the key players in their AO and foster dialog between their units and the local security forces. MND-N emphasized the need for local and regional engagements and activities designed to increase employment, while our higher sustainment command, the 316th Sustainment Command (Expeditionary), directed continued support to MNC-I lethal and nonlethal operations. All levels emphasized humanitarian assistance initiatives to help ensure that the Iraqi public viewed its government as both legitimate and able to respond to the needs of the people.

With this guidance in mind, the commander of the 3d Sustainment Brigade outlined his concept for the brigade's NLE strategy. He emphasized the need to fully integrate all NLEs with the actions of maneuver commanders and to conduct them in conjunction with Iraqi Army and Iraqi Police officials. The NLE strategy would support the brigade's logistics convoys by reducing threats in identified hot spots on main supply routes (MSRs) and alternate supply routes (ASRs). The NLE strategy also would engender goodwill with the Iraqi people and key leaders; teach



The local chief of the Iraqi Police meets with the 17th Combat Sustainment Support Battalion. Building a strong relationship with the chief helped to improve security along convoy routes.

Iraqis skills so they could help themselves; provide jobs for Iraqis that would assist with economic development; and meet the MNC-I and MND-N commanding generals' intent to support Iraqi economic stability, growth, governance, and security.

In order to facilitate this intent, oversight of the NLE strategy was given to the brigade's S-3 operations section. The six key types of NLEs identified during mission analysis were—

- Humanitarian missions, such as distributing sundry packs and conducting medical engagements.
- Pamphlet-targeting and counter-propaganda efforts to build support for the Iraqi Security Forces and increase interactions with the Iraqi Army and Iraqi Police.
- Social and leadership engagements, including dinners with local sheiks and school visits.
- Adopt-a-village programs.
- Job creation programs, such as adopt-a-highway programs.
- Economic and infrastructure initiatives, such as development of an Iraqi trucking network.

In order to best implement these proposed programs, the brigade S-2 analyzed our AO using targeting techniques. It was determined that, because of its large size, the AO should be broken down into five areas of interest or influence (AOIs) and that each of these AOIs should be assigned to one or more of the brigade's subordinate battalions. After the S-2



Key Elements of 3d SB NLES

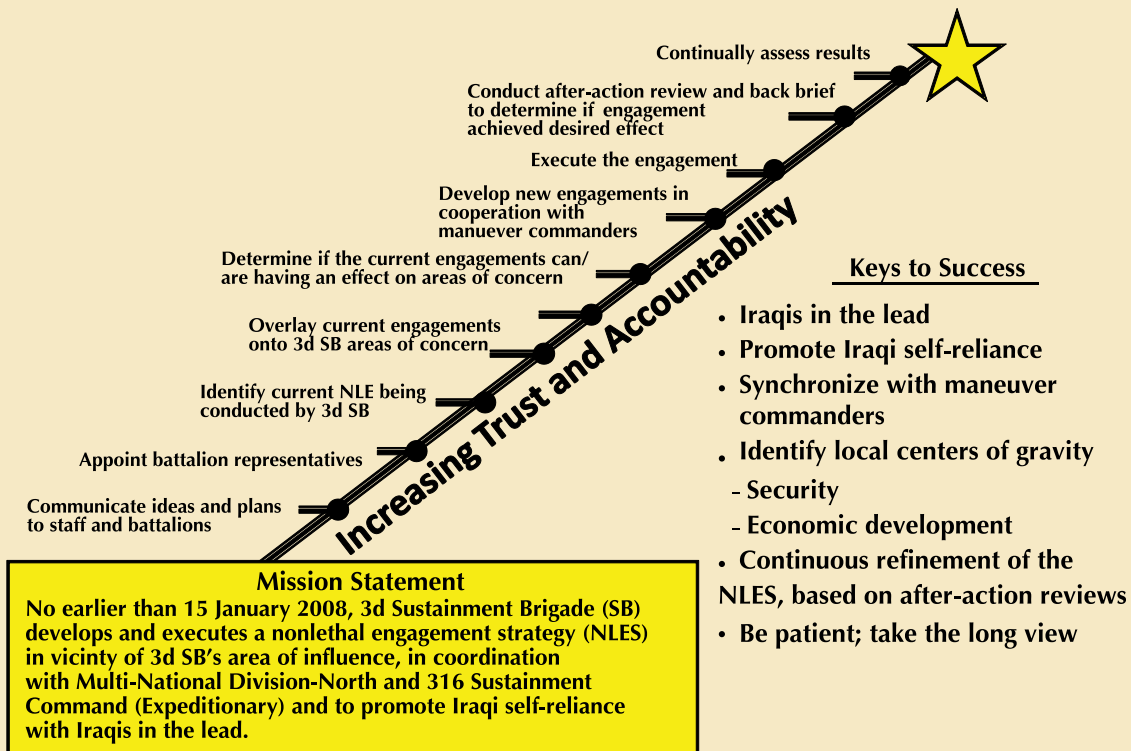

The 3d Sustainment Brigade strategy for conducting nonlethal engagements.

analyzed the individual AOIs, specific towns and engagements were targeted to yield the greatest benefits for both the Iraqi people and the brigade.

All NLEs proposed by the battalions were synchronized with the maneuver commanders and performed in conjunction with local Iraqi Police and Iraqi Army officers to put an Iraqi “face” on the missions. By targeting specific villages in the vicinity of named AOIs along the routes our logistics convoys traveled, we were able to help the Iraqis move toward the goals of stability and self-reliance while reducing threats against our convoys and Soldiers.

AOI 1: Habur Gate

Habur Gate, on the Turkish border, was manned by a logistics task force (LTF) provided by the 3d Sustainment Brigade Special Troops Battalion. The LTF operated a convoy support center and served as a liaison to the brigade support operations cell in order to observe, assess, and report the movement progress of coalition forces sustainment stocks and fuel. Because of its important mission, the LTF was immediately identified as a candidate for NLEs. Three major locations in the vicinity of Habur Gate were selected for NLEs: the village of Zahko, the village of Dahouk, and Habur Gate itself.

Zahko, in an impoverished Kurdish region, was chosen to be a part of the brigade’s adopt-a-village program, particularly for engagements with the local nursery school, elementary school, and military academy in a dual humanitarian and training advisory capacity. The emphasis in the Zahko engagements was to foster a positive relationship between U.S. Soldiers and the youth in the region through the distribution of school supplies, toys, and clothing. The LTF also partnered with the Iraqi Army and Iraqi Police to provide advisory support to the Zahko Military Academy in areas such as combat lifesaver training, range management, physical training, and the roles of officers and noncommissioned officers in the military. This partnering was important in fostering the self-reliance and self-sufficiency of the Iraqi military through the train-the-trainer concept.

The emphasis in Habur Gate was on synchronizing and promoting communication between coalition forces and officials in Iraq and Turkey. In particular, the LTF arranged for a meeting among the Kurdish customs personnel, the Turkish customs personnel, the coalition forces movement control team, the Turkish liaison officer, and personnel of the consulate’s office in Ankara, Turkey. To support border security, the LTF conducted a weekly meeting with the Customs Facility Secret

Police, the Habur Gate Port Police, and U.S. military representatives to discuss matters of force protection; this allowed all concerned parties in the AO to compare notes on security topics and foster a sense of teamwork between the coalition forces and their Kurdish hosts.

AOI 2: Mosul Region

The city of Mosul and its surrounding area have traditionally been named an area of interest for coalition forces in the region. That had an impact on the numbers and types of NLE missions that the 3d Sustainment Brigade could conduct. One village in the Mosul region, Filfay, was identified as a possible location for humanitarian NLEs.

The 87th Combat Sustainment Support Battalion (CSSB) conducted a humanitarian mission in cooperation with the 3-1-2 (3d Battalion, 1st Brigade, 2d Infantry Division, Iraqi Army) Military Transition Team (MITT) that targeted the Sunni Arab neighborhood of Al Thubat in eastern Mosul. The intent of the operation was to strengthen relationships between the Iraqi Security Forces and coalition forces within the community. During this operation, the unit spoke with local residents and distributed toys, stuffed animals, and coloring books to children.

The 87th CSSB also conducted several visits with the local Iraqi Army battalion commander and his staff and with the commander of the Northern Operations Center. These visits produced critical intelligence information on the routes used during our logistics convoys and the atmosphere in the villages along those routes. This greatly increased our knowledge of the routes and helped us to identify key focus areas for future NLEs.

AOI 3: Q-West

The Qayyarah region was managed primarily by the Soldiers of the brigade mayor's cell and base defense operations center (BDOC). Five different

Sheiks attend the Q-West souq. Monthly souqs provided an opportunity for local leaders to meet with local government officials.



organizational headquarters—the 2d Battalion, 123d Armor Regiment; the 332d Rear Area Operations Center; the 1st Battalion, 175th Infantry Regiment (1-175 Infantry Battalion); the 76th Special Troops Battalion; and Task Force (TF) 113 from the Indiana National Guard—transitioned into mayor's cell and BDOC positions over the course of the brigade's tenure at COB Q-West; each left the NLE strategy more robust than they found it.

The overall strategy for Qayyarah and the surrounding villages focused on several key areas: humanitarian efforts, particularly support for local schools and medical facilities; economic support through the hiring of local national workers in DPW, adopt-a-village and adopt-a-highway initiatives; "souqs" (markets) held at COB Q-West for Iraqi vendors; and patrols within the villages, which had the added benefit of making the inhabitants feel safer thanks to a robust coalition forces presence.

The humanitarian efforts were similar to those in other regions within the brigade's AO, such as visits to village schools to give out school supplies and children's shoes. Female Soldiers from the COB mayor's cell conducted several focused engagements with the women of Qayyarah, Kreidi, Al Tina, and Zalila, speaking with the women in private and distributing health-care products. The brigade headquarters as well as its BDOC and mayor's cell maintained a strong relationship with several local sheiks and mukhtars, regularly hosting them at dinners at the COB and in turn being hosted by them in their villages.

The economic support provided by the COB to the Qayyarah region was particularly robust. The COB employed approximately 500 local nationals, with 350 from Ninewa Province and the remainder being local villagers employed by the DPW. Nearly \$3.28 million was given out in wages over the period of the brigade's deployment, and a variety of COB improvement projects were completed entirely by using local national labor.

Headed by the BDOC, the adopt-a-highway program addressed two desired objectives of the NLE strategy: hiring local nationals to pick up trash along the COB access roads to make the conditions for emplacing improvised explosive devices less ideal; and targeted temporary hiring of unemployed men from Al Tina to improve that village's ability to provide for the basic needs of its residents, improve the security of the base, and decrease the possibility of those men being recruited by insurgents.

A more recent development in the economic support provided to the region was the establishment of monthly souqs, which enabled local vendors to come onto the COB over a period of 2 days. Aside from the monetary benefits to the 3 to 15 vendors who participated monthly, the souqs paid enormous dividends by providing a



Soldiers of the 87th Combat Sustainment Support Battalion package school supplies for distribution in the Mosul region.

927th CSSB worked closely with civil affairs and MiTT units and the battlespace owners to deliver humanitarian aid, specifically school supplies, sundry packs, clothing, toys, and toiletries to villages that demonstrated strong support for the existing Sons of Iraq program. [The Sons of Iraq are groups of primarily Sunni citizens who cooperate with U.S. forces to fight Al Qaeda terrorists and Shiite militias.] By rewarding participation, the program was designed to strengthen existing relationships with Iraqi partners.

The 391st CSSB and TF 1-151 continued and expanded this program deeper into the villages in the area, including Al Alam, Wynot, Al Sequor, and Al Hamran, in partnership with civil affairs and psychological operations assets drawn from the local maneuver forces. During village visits, the local sheik and other village leaders, as well as business owners, were able to discuss how well they were able to function, what support the city of Tikrit was giving them, and what they lacked to be able to operate more fully and efficiently. The program targeted local villages with strong Sons of Iraq participation and assisted the MiTT in making deliveries of humanitarian supplies in Tikrit. Approximately seven villages participated in the program, which helped to strengthen relationships with local officials, the Iraqi Police, and the Iraqi Army and to legitimize the position of those authorities in the local community.

neutral location for local government officials to meet and discuss issues affecting their villages.

Finally, the BDOC used its already scheduled counter-rocket patrols to deny insurgents a staging area to conduct attacks against COB Q-West and to engage with local leaders and the populace to foster a positive relationship of trust and early detection of insurgent activity. Local residents expressed their belief that they were safer when Coalition Forces made frequent stops in their villages.

These NLEs had benefits beyond the obvious humanitarian and economic improvements. The partnerships with the local villages resulting from the NLEs produced an additional layer of security for the COB because people in the villages were far more likely to report suspicious activity to the BDOC than they would have been without the engagements.

AOI 4: Speicher Route

Over the course of the 3d Sustainment Brigade's tenure, the Speicher Route was managed by three battalions: the 927th CSSB, the 391st CSSB, and TF 1-151 Infantry. The NLE strategy in the vicinity of COB Speicher was primarily one of humanitarian assistance and cooperation with civil affairs and MiTT units. The 927th CSSB's nonlethal force initiative, Operation Clear Skies, targeted villages and communities around COB Speicher and along major MSR, as well as in the city of Tikrit. The operation was designed to foster goodwill within the 927th CSSB's AO in the hope of reducing attacks. The Soldiers of the

AOI 5: Warrior and Sykes Route

The Warrior and Sykes Route was assigned to the 17th CSSB out of COB Q-West. The major initiatives of this program were robust medical support to villages along the route and leader engagements with the local chief of the Iraqi Police to foster security on the routes that logistics convoys traveled.

Representative of the medical support to the villages was the December 2007 NLE conducted by D Company, 1-175 Infantry Battalion, and the 17th CSSB. They participated in a civilian medical engagement (CME) with Soldiers from the Iraqi Army and a MiTT in the village of Marhanna to bolster the villagers' trust in coalition forces and the Iraqi Army. The main tasks of the CME

were to provide overall security for the engagement and allow coalition forces medics to observe Iraqi medical personnel. In addition to passing out school and hygiene supplies to the residents of Marhanna, coalition forces and Iraqi medics treated over 120 patients from the village during the CME. Influencing the residents of Marhanna was of crucial importance because of the village's proximity to the main route that the 17th CSSB traveled to outlying supported FOBs.

Representative of the leader engagements conducted along the Warrior and Sykes Route was the NLE with the local police chief. The purpose was to conduct a force protection assessment of the chief's compound. The chief had a great deal of influence in the vicinity of several important ASRs, and building a strong partnership with him would lead to continued safety of our logistics convoys as they operated along the routes to outlying supported FOBs. This relationship also paid dividends when the 17th CSSB conducted increased convoys to COB Speicher along MSRs as part of the improved concept of support developed in the later part of the OIF 07–09 rotation.

Success Stories and Achievements

The 3d Sustainment Brigade conducted a total of 14 training sessions with local nationals in trade skills such as carpentry and construction, which increased the marketability of the men who participated and provided needed economic stimulus to the region. The brigade also conducted two joint CMEs with Iraqi Army, Coalition Forces, and local doctors participating, overseeing medical treatment to more than 180 Iraqis and vastly improving the perception within the villages of the capabilities of their local doctors. Overall, approximately \$102,000 in humanitarian aid was disbursed. The brigade distributed over 1,700 pairs of shoes, 40 desks, 150 toys, 1,000 school packs, 800 sundry packs, and 300 other items, including clothes and hygiene items. The brigade also paid \$750 in local teachers' salaries, another \$750 in support of the adopt-a-highway program, and \$3.28 million in salaries for local nationals employed by the DPW.

It is clear that the NLE strategy developed and implemented by 3d Sustainment Brigade and its subordinate battalions had an enormous impact on the regions in which the brigade's Soldiers operated.

Suggestions for Implementing NLE

The development and continuous improvement of an NLE strategy is vitally important to the overall long-term success of the coalition forces mission in Iraq. The 3d Sustainment Brigade learned several lessons that may aid other sustainment brigades in developing their own NLE programs.

First, sustainment brigades should conduct detailed targeting to determine where NLEs may provide the most benefit for both the brigade and the local populace with whom that brigade regularly interacts. The 3d Sustainment Brigade was able to pinpoint particular villages along its routes and, through engagements with local leaders and residents, was able to reduce the number of enemy events experienced by logistics convoys and improve the type and quality of intelligence gathered in those regions.

Second, sustainment brigades should nest their efforts within ongoing kinetic and nonlethal operations. The 3d Sustainment Brigade was able to conduct several joint missions with civil affairs, psychological operations, and MiTT assets of the various maneuver headquarters with which it interacted; each of these missions paid huge dividends in increasing security throughout the brigade's AO.

Finally, sustainment brigades should focus their efforts not only on humanitarian aid but also on initiatives that provide an economic stimulus to the region and foster dialog between the Iraqi people and coalition forces. We found that initiatives like the souqs provided a dual benefit: they offered monetary benefits to local vendors, and they benefited the COBs by opening communication channels between local leaders and Coalition Forces and among the different levels of tribal leadership in our AO.

Building relationships with Iraqis is one of the key factors in the counterinsurgency guidance issued by General David H. Petraeus on 21 June 2008. A successful NLE strategy will be geared toward the promotion of economic stability, the security of the populace, and Iraqi self-reliance. Such a focus will greatly contribute to the long-term stability and security of not only the regions in which sustainment brigades operate but of Iraq as a whole.

ALOG

CAPTAIN LLOYD E. WARREN III IS THE BRIGADE ASSISTANT S-3 OF THE 3D SUSTAINMENT BRIGADE. HE HOLDS A B.S. DEGREE IN ACCOUNTING WITH AN EMPHASIS IN COMPUTER INFORMATION SYSTEMS FROM NORTHERN ARIZONA UNIVERSITY AND IS WORKING ON A MASTER'S DEGREE IN ORGANIZATIONAL AND SECURITY MANAGEMENT FROM WEBSTER UNIVERSITY. HE IS A GRADUATE OF THE MILITARY POLICE OFFICER BASIC COURSE AND THE MILITARY POLICE CAPTAINS CAREER COURSE.

CAPTAIN BRITTANY R. WARREN IS THE BRIGADE ADJUTANT FOR THE 3D SUSTAINMENT BRIGADE. SHE SERVED AS A CHEMICAL PLATOON LEADER DURING OPERATION IRAQI FREEDOM 04-06 IN 2005. SHE HOLDS A B.S. DEGREE IN BIOLOGICAL ANTHROPOLOGY AND ANATOMY FROM DUKE UNIVERSITY AND IS A GRADUATE OF THE CHEMICAL OFFICER BASIC COURSE.



BY COLONEL LINWOOD B. CLARK

The Health of the Command

The 3d Sustainment Brigade's special staff met regularly to discuss key issues that affected the lives, morale, and welfare of the brigade's personnel.

During the 3d Sustainment Brigade's deployment in support of Operation Iraqi Freedom 07–09, the brigade special staff played an integral role in day-to-day operations. The brigade relied heavily on a regular special staff meeting known as the “health of the command” to monitor the health, safety, and morale of its Soldiers.

Special Staff Organization

Brigade special staffs perform a diverse group of important functions. In the 3d Sustainment Brigade, the special staff includes the unit ministry team (UMT), surgeon cell, safety office, public affairs office, equal opportunity (EO) office, retention office, and brigade judge advocate (BJA) office. While deployed, the brigade was unique among its sister sustainment brigades in that, in addition to its normal sustainment operations, it was also responsible for the contingency operating base (COB) mayor, base defense, and force protection functions. Because of these additional duties, the brigade was assigned a combat health team, dental services assets, veterinary services assets, a preventive medicine team, and an inspector general (IG). These specialties, along with the existing special staff of professional officers and noncommissioned officers, formed the nucleus of the eyes and ears of the brigade command.

An additional member of this professional cadre was the brigade sexual assault response coordinator (SARC). Although not officially a member of the special staff, the brigade SARC played a vital role in ensuring that all Soldiers in the brigade were trained and aware of the proper response to sexual assault incidents. So in that capacity, the SARC fell under the jurisdiction of the special staff umbrella.

The command immediately realized that this large group of individuals needed a single, authoritative head to ensure they were synchronized with the operations of the brigade and the primary staff. With that goal, the day-to-day oversight of the special staff was provided by the brigade's deputy commanding officer (DCO).

Health of the Command Meetings

The specialized skills and unique capabilities of the diverse special staff were apparent in the bimonthly

health of the command meetings. These forums, developed by the brigade commander, were used to bring all of the special staff together to discuss key issues that were usually sensitive in nature and had a significant impact on the lives, morale, and welfare of Soldiers, civilians, and contractors in the brigade and on the COB. The meetings afforded the brigade commander, DCO, and command sergeant major the opportunity to discuss concerns and issues and formulate courses of action collectively with all of the special staff.

The health of the command council reviewed trends and cases—always discussed under the condition of anonymity—that were of common interest to many of the members and that affected Soldiers within the brigade. Many of the cases discussed during the health of the command meetings crossed professional boundaries. For example, the legal team brought to the command's attention that some Soldiers were huffing canned air to get high. The command's investigation revealed that many of the Soldiers involved either had pre-existing issues or suffered from some form of depression. The health of the command council discussed this problem and decided to refer Soldiers for mental health treatment or to the chaplain.

During the deployment, the brigade was tasked by Multi-National Corps-Iraq and the 316th Expeditionary Sustainment Command (ESC) to form a suicide prevention response team. Many members of the special staff were involved in developing standing operating procedures, training guidance, and unit responsibilities to address the major issues that result in suicide or attempted suicide. Special staff personnel also scheduled monthly and quarterly meetings with key leaders and drafted a policy letter on suicide prevention for the brigade commander's signature. Thanks to efforts from the brigade surgeon, the combat stress team, the chaplain, the BJA, and the DCO, the brigade met all of its suicide prevention requirements.

Special Staff Functions

Special staff personnel came together to discuss and work through challenges most of the time without additional guidance. They functioned as a team to ensure that Soldiers in the command succeeded in day-to-day operations and worked through personal or professional

issues. Special staff members assisted Soldiers with issues at home and generally lifted their spirits with kind words or prayers. Each of the sections brought their own unique strengths and capabilities to the table.

UMT. The UMT's focus was ministering to the Soldiers' spiritual needs, which the command recognized as essential to maintaining strong morale over lengthy deployments. The brigade UMT's contributions to the health of the command meetings were to educate brigade leaders on Soldier counseling trends, provide an analysis of religious services and attendance, and discuss special events sponsored by the brigade chaplain staff or one of the subordinate UMTs. The brigade UMT also discussed the most significant emotional health areas that affect Soldiers during the deployment, such as stress, grief, workplace morale, and family and marital concerns.

Brigade surgeon cell. The surgeon cell provided an analysis of the brigade's medical threats for the commander. Surgeon cell personnel outlined the medical issues that most often affected Soldiers. These medical issues were quite diverse and included battle injuries, combat operational stress, sports injuries, and infections. After presenting objective data, the surgeon cell provided recommendations on the best ways to mitigate these threats.

Brigade safety office. The safety office contributed to the health of the command meetings by providing awareness of safety-related issues and concerns that could potentially threaten the overall readiness of personnel and equipment. The trends documented by the safety office and the data presented by the surgeon cell tended to overlap. The safety office applied management principles like trend analysis to identify new techniques and methods to prevent accidents and promoted the advancement of safety awareness through educational programs.

Brigade EO adviser. The EO adviser brought to the table issues raised by command climate surveys, EO reports, and other analysis tools. The EO adviser used anonymous data to present underlying issues to the other sections.

Public affairs office. The public affairs office produced publications and marketed stories as a means for the command and key staff members to distribute general information that could affect all personnel on the base, thus ensuring a healthy command climate. The public affairs office also ensured that accurate information was being released to the public.

BJA. The BJA contributed to the health of the command meetings by reporting misconduct that occurred within the brigade. The BJA provided insight into legal trends and analyses associated with Soldier misconduct and legal issues.

IG. The IG is a special staff position normally located at the senior Army command level and higher.

The 3d Sustainment Brigade therefore was not authorized an IG as part of the special staff. However, the brigade was very fortunate to be augmented with an assistant IG from the 316th ESC. The 316th ESC's assistant IG was assigned the task of supporting COB Qayyarah-West and 3d Sustainment Brigade Soldiers located at other forward operating bases and COBs throughout Multi-National Division-North. Although the IG team was rather small to cover such a huge area, it succeeded in supporting the commander through the four main functions of an IG: inspections, assistance, investigations, and teaching and training.

Combat stress control team. Although not an organic part of the 3d Sustainment Brigade, the 85th Medical Detachment's combat stress control team (CSCT) played a vital role in maintaining the fighting force and significantly contributed to the overall health of the command. Integrating into the 3d Sustainment Brigade as a part of the special staff allowed the CSCT to serve as effective consultants. Coordinating with other members of the special staff promoted a multidisciplinary approach to behavioral health issues.

The special staff's coordination with the CSCT increased command visibility on behavioral health issues within the brigade. It also allowed for a more proactive approach in dealing with behavioral health problems and lessened their negative impact on overall unit morale and cohesion. The CSCT's close relationship with the 3d Sustainment Brigade directly assisted Soldiers and units by increasing awareness of behavioral health issues and promoting individual services and unit-level education.

The efforts of the special staff, teamed with other units and elements of the brigade staff, made the 3d Sustainment Brigade successful in meeting its mission to sustain coalition forces, civilians, and contractors on the battlefield in Multi-National Division-North. The special staff's mission to provide the commander a forum to discuss and develop solutions for troubled areas in the command was extremely successful. The unique skills and expertise of each member of the special staff and the health of the command council truly lived up to the brigade motto, "Heart of the Rock." **ALOG**

COLONEL LINWOOD B. CLARK IS THE DEPUTY BRIGADE COMMANDER OF THE 3D SUSTAINMENT BRIGADE, WHICH WAS DEPLOYED IN SUPPORT OF OPERATION IRAQI FREEDOM WHEN HE WROTE THIS ARTICLE. HE HAS A MASTER'S DEGREE IN ADMINISTRATION FROM CENTRAL MICHIGAN UNIVERSITY, AND HE IS A GRADUATE OF THE COMBINED ARMS AND SERVICES STAFF SCHOOL, THE INSPECTOR GENERAL COURSE, AND THE ARMY COMMAND AND GENERAL STAFF COLLEGE.



Supporting Immediate Response 2008

As U.S. Army Europe continues to modernize its forces and operations, the 21st Theater Sustainment Command (TSC) is leading the effort in transforming logistics operations across Europe. The 21st TSC demonstrated its capabilities with the reception, staging, onward movement, and integration

(RSO&I) process for Immediate Response 2008, a training exercise conducted by the United States, Georgia, Ukraine, Azerbaijan, and Armenia outside of Tblisi, Georgia. Immediate Response is an annual, bilateral security cooperation exercise that is focused on interoperability training and is designed to



*Soldiers record the equipment tracking numbers as they inspect items arriving at the Vaziani railroad station.
(Photo by 2LT Lucía Rojas)*

At left, Georgian military police and Georgian Army transporters stand ready to receive the 3d Battalion, 25th Marine Regiment, into Tbilisi and then provide an escort into the Vaziani training area. (Photo by CPT Bryan Woods)

promote understanding and cooperation among military forces of the United States and its allies.

Soldiers from the 39th Transportation Battalion in Kaiserslautern, Germany, the 14th Transportation Battalion and the 386th and 969th Movement Control Teams (MCTs) in Vicenza, Italy, and the 489th Cargo Transfer Company in Jacksonville, Florida, participated in the exercise. They planned, coordinated, and conducted the first military movement of personnel, equipment, and containers from Italy, Germany, and the continental United States (CONUS) into Georgia, using eastern European railroads and waterways.

The RSO&I process consists of five deployment phases: predeployment activities, movement to the ports of embarkation (POEs), strategic lift, theater reception, and theater onward movement. Each unit deploying to a theater of operations must execute this process every time for both the departure and the return. The movement phase is the sequencing of units to the POE, and the strategic lift phase begins with the departure from the POE and ends with arrival in theater. The reception phase is the arrival of forces at air- and seaports of debarkation (PODs).

The planning process started at the tactical level, with the Southern European Task Force (SETAF) chairing numerous interim progress review meetings. The 21st TSC provided the reachback capabilities to the strategic transportation providers and to the Military Surface Deployment and Distribution Command.

A Georgian Army soldier welcomes two Soldiers from the 18th Military Police Brigade, who escorted the train bearing U.S. equipment to the Vaziani railroad station. (Photo by 2LT Lucia Rojas)



The 21st TSC was responsible for coordinating the movement of over 170 pieces of equipment from various locations around Europe and CONUS and for receiving the equipment in Georgia. The TSC

used several seaports of embarkation and a variety of transportation modes, including a rail ferry across the Black Sea. The MCTs synchronized the movement of personnel and equipment over three rail lines to the



Southern European Task Force Soldiers in Italy prepare their individual shipping unit for shipment by rail to Georgia. (Photo by 2LT Lucia Rojas)



A Soldier from the 386th MCT inspects the military shipping labels on a container as he conducts an inventory of all 170 pieces of equipment that were shipped from various sites in Europe and the continental United States for training exercise Immediate Response 2008. (Photo by 2LT Lucia Rojas)

Vaziani railroad station in Georgia. Multiple commercial carriers played a critical role in the RSO&I process, making it easier to coordinate carriers in several countries.

Moving personnel from various locations around the world to Georgia for Immediate Response 2008 was no easy task. Soldiers from the 386th and 969th MCTs planned and coordinated the transportation for and receipt of over 1,200 Soldiers, Sailors, Airmen, and Marines. The 21st TSC also coordinated with the Georgian Ministry of Defense for medical support at



A Soldier verifies equipment and container information before equipment is unloaded at the Vaziani railroad station. (Photo by 2LT Lucia Rojas)

the port and railroad station and for the protection of U.S. Soldiers while they unloaded railcars.

The 21st TSC MCTs managed both the rail operations and the aerial port of debarkation, an air terminal where troops, units, military-sponsored personnel, unit equipment, and materiel unloaded. The MCTs ran into normal challenges, such as delayed and canceled flights and lost luggage. Overcoming these challenges, they made the travel an effortless process for the passengers. The MCTs also had to coordinate with the U.S. Embassy, Georgian Ministry of Defense, customs officials, the Georgian Air Force, and the border police to ensure all passengers met host nation customs requirements.

Colonel Charles Maskell, the 21st TSC support operations officer said, “The Georgians have been great teammates from the beginning and throughout the planning conferences. We informed them of our requirements and they quickly identified what capabilities they had to support the mission.” **ALOG**

ARMY LOGISTICIAN THANKS MAJOR BRYAN WOODS, DEPUTY PUBLIC AFFAIRS OFFICER, 21ST THEATER SUSTAINMENT COMMAND, FOR PROVIDING THE STORY AND PHOTOS FOR THIS ARTICLE.

Improving Materiel Readiness for the Joint Warfighter

BY MAJOR ERIC MCCOY

Seven years into the Global War on Terrorism, U.S. Armed Forces are decisively engaged in their longest period of sustained conflict since the Vietnam War. Joint logisticians are focused on providing world-class operational availability of systems to the warfighter and are constantly in pursuit of modernizing our military services. However, logisticians face two concerns with providing modern equipment. First, the cost to deliver this high level of system readiness remains unknown. Second, we in the Department of Defense (DOD) need to take an introspective look at how we make decisions to upgrade combat systems.

For example, the high-mobility multipurpose wheeled vehicle has a 1975-vintage engine that could have been replaced in 1985 with a new, smaller engine that would have performed better, been more reliable, used less gas, and lasted longer. Two compelling reasons explain why DOD did not institute a fleet-wide upgrade. First, the acquisition and sustainment communities could not compellingly demonstrate a return on the investment. Second, it could be argued that the agencies responsible for funding this purchase had little interest or involvement with spiraling life-cycle costs.

The purpose of this article is to articulate the need for embracing key tenets of total life-cycle systems management. Its goal is to communicate to all maintenance stakeholders (including our industry partners, suppliers, the acquisition community, and tactical end-users) the importance of linking acquisition and sustainment to support the joint warfighter. The intended outcome is for decisionmakers at all levels to base decisions for equipping the force on a total life-cycle scope, providing reliable and available weapon systems for the best value.

Achieving Systems Availability

The joint logistics and acquisition communities must focus collaboratively on delivering systems availability to the warfighter. This delivery, otherwise referred to and measured as readiness, should concentrate on three metrics: component or subsystem readiness, system readiness, and fleet readiness. Systems must be designed with three priorities in mind: considering sustainment upfront during the design process, emplacing predictive maintenance enablers in weapon platforms, and effectively determining the

best investment for DOD's next incremental dollar in sustainment capability.

We can model future DOD business processes using the many examples of such synergy and process improvement in the civilian sector. The 2007 DOD Maintenance Symposium provided various examples of commercial best practices from our industry partners that help us to embrace total life-cycle systems management. These include—

- Integrated supply chain efforts modeled on successes in the retail industry.
- Systems created with built-in predictive maintenance technologies similar to commercial automotive industry designs.
- Improved asset visibility using emerging technologies and new procedures as represented by corporate information technology organizations and logistics providers.

Maintainers, regardless of service or particular subspecialty, perform three functions: repairing equipment when it breaks, improving processes so that equipment breaks less often, and working with the design community to make equipment that is easier to maintain and repair. To aid these efforts, DOD should refocus its management efforts to concentrate on two key measures of effectiveness. First, we must assess effectiveness based on system readiness to the warfighter; this measurement is manifested at the tip of the spear—in the hands of the warfighter. Second, we must assess effectiveness concerning value.

The discussion above focuses on a central objective: improved readiness at best value. This objective can be accomplished through two means: the enhancement of total life-cycle systems management processes and the availability of key performance parameters focused on materiel availability.

Linking Acquisition and Sustainment

To enhance our use of the life-cycle systems management approach to managing our weapon systems, the program management focus should be expanded to include fleet management, linking the acquisition and sustainment communities together under one entity to provide cradle-to-grave support for fielded combat systems. Our current structure focuses program managers primarily on acquisition costs and schedules since

this is how their performance is generally measured. Sustainability, if not properly designed and addressed upfront in the acquisition process, can be traded away for short-term operational gains, often at the expense of long-term materiel readiness.

For example, a weapon system fleet manager sees the cost to operate in Korea is \$230 an hour versus \$180 an hour to operate in Germany. The fleet manager would reasonably ask why we have such different operating costs for the same system. Possible reasons might include vehicle age; operator training; equipment use tactics, techniques, and procedures; the operating environment; or the maintenance approach. Knowing the reasons behind the variance, the legacy fleet manager can pass information from the tactical and operational levels back to the acquisition community to support system improvement and redesign. The result of having fleet managers who have a stake in cradle-to-grave systems performance is the delivery of weapon systems that meet objective requirements.

A critical component of effective life-cycle systems management is knowing how much readiness each additional dollar buys. In an ideal situation, fleet managers have adequate information to analyze the overall costs of sustainment alternatives effectively and select an option that ensures the weapon system will provide the lowest total cost of ownership consistent with an acceptable level of availability. This analysis is continuous, starting early in system design and continuing through system improvements until final system retirement. However, the information required to perform this kind of analysis is not available in the current environment. Instead of analyzing numerous alternatives, program managers should choose one concept for maintenance support and discuss why they chose this course of action in support of system design. Armed with the knowledge behind their sustainment rationale, informed decisions can be made in an austere budget environment.

Developing Materiel Availability Metrics

The full effect of life-cycle costs should be considered because even as our equipment becomes less expensive to buy, it could be costly to maintain. One way that we can address this concern is by advocating continued use of the materiel availability key performance parameter (KPP) and its two supporting key system attributes, reliability and ownership cost.

Chairman of the Joint Chiefs of Staff Manual 3170.01C, Operation of the Joint Capabilities Integration and Development System (JCIDS), defines KPPs as “those attributes or characteristics of a system that are considered critical or essential to the development of an effective military capability and those attributes that make a significant contribution to the characteris-

tics of the future joint force.” JCIDS defines key system attributes as attributes or characteristics considered crucial in achieving a balanced solution to a KPP or other key performance attributes deemed necessary.

Changes to KPPs are approved by the Joint Requirements Oversight Council, which consists of the vice chairman of the Joint Chiefs of Staff and the vice chiefs of staff of the four military services. Changes to key system attributes are approved at the four-star or principal equivalent level from the program sponsor’s parent service. Both KPPs and key system attributes enable feedback from the test and evaluation efforts to the requirements process.

The materiel availability KPP was added to the JCIDS process in May 2007. The purpose of this addition was to mandate consideration for logistics support early in the acquisition process. The value of the KPP is derived from the operational requirements of the weapon system, assumptions about its operational use, and the planned logistics support needed to sustain it. In order for the program manager to develop a complete system that will provide warfighting capability, sustainment objectives must be established and the performance of the entire system must be measured against those metrics. Materiel availability measures the percentage of the total inventory of a system that is operationally capable (ready for tasking) of performing an assigned mission at a given time based on materiel condition. Materiel availability also indicates the percentage of time that a system is operationally capable of performing an assigned mission. This KPP focuses on maximizing availability and reliability of the weapon system at best cost value.

Using the Sustainment KPP

System reliability is obviously a critical component of combat readiness. On the Joint Staff, this is acknowledged in the JCIDS process by mandating reliability as one of two supporting key system attributes for the sustainment KPP. Reliability measures the probability that the system will perform without failure over a specified interval. Increased reliability can also decrease the logistics footprint, allowing predictions of downtime for scheduled maintenance operations. A fleet of weapon systems with easily replaceable components, preventive service indicators, and common repair parts could reduce the warfighter’s logistics requirements.

It is important to consider not only acquisition costs for weapon systems, but also the cost to maintain them throughout their life cycle. Sustainment cost is not the defining factor in systems acquisition, but it should be a significant variable in the decision process because the services must pay operations and maintenance (O&M) costs throughout the system’s life cycle, which

Weapon system sustainment consumes 80 percent of our logistics resources, or approximately \$64 billion per year. Currently, weapon system sustainment is provided by functionally focused organizations that optimize within their own business structures . . . we fight with capabilities and systems, not functions.

—Louis A. Kratz, Randy T. Fowler,
and Jerry D. Cothran,

Program Manager, September–October 2002

is often measured in decades, not years. As O&M dollars made up 35 percent of the fiscal year 2009 DOD budget before supplemental appropriations, we cannot afford to take the taxpayer for granted as we provide support to the warfighter.

Life-cycle systems management requires that we become better attuned to total ownership cost, which is addressed in the JCIDS process as the second key system attribute for the sustainment KPP. This provides balance to the sustainment solution by ensuring that the operations and support (O&S) costs, such as maintenance, spares, fuel, and support, that are associated with materiel readiness are considered in making program decisions. The ownership cost key system attribute is ultimately based on the O&S cost estimating structure elements specified in the Operating and Support Cost-Estimating Guide published by the Office of the Secretary of Defense Cost Analysis Improvement Group.

A key to understanding the ownership cost key system attribute is to clarify the term “cost.” We should consider fleet costs, which should be defined as the cost to operate the system for a specific measurement of time or distance. We should also consider readiness cost, which should be defined as the cost to deliver a specified level of availability and the cost to deliver more. In some cases, additional improvements to reliability may be so expensive that additional platforms may be a better investment. Costs and effects of mission failure or catastrophic system malfunction also must be weighed against tradeoff decisions.

Members of the sustainment community must ask themselves, “To what end? What is the end state or purpose of our logistics efforts?” Too many great service members, DOD civilians, and contractors work too hard to do things that make little difference when all is said and done or a lot less difference than an alternative use of time and resources might. For anything we do, or spend, we should apply the effort within a process and show the results. The chosen methodology should apply to all aspects of sustainment.

Establishing Corporate Models

Policies must be continually developed and improved to ensure that DOD is partnered with

industry in productive relationships that benefit the warfighter. The joint logistician can learn many lessons from corporate models. These models have to be effectively designed. Otherwise, companies go out of business. We have a similar charge in the DOD community: our models have to be effectively designed, or our warfighting capability is diminished. The key issue is to agree on what DOD and our business partners are collectively trying to do so that our efforts complement, rather than conflict with, each other. Sometimes our methodology will require tough judgment calls, such as determining how much the enhanced effectiveness of a system is worth. This requires communication between the acquisition and sustainment communities as DOD attempts to field systems that are reliable, maintainable, and cost-effective from cradle to grave.

Ultimately, the fact that we can always do better should not detract from the importance of the work we are doing. None of the Soldiers, civilians, or contractors engaged in the Global War on Terrorism are trying to do a bad job. If our purpose as logisticians is to provide the joint force commander freedom of action, we must understand how to make it happen. Weapon system availability is what we deliver to the joint force commander; to accomplish that, we must manage the weapon systems we have using a life-cycle management approach and we must procure reliable weapon systems at the best value. **ALOG**

MAJOR ERIC MCCOY IS ASSIGNED TO THE ARMY INSPECTOR GENERAL AGENCY. HE WAS AN ACTION OFFICER FOR THE MAINTENANCE DIVISION, J-4, JOINT STAFF, WHEN HE WROTE THIS ARTICLE. HE HOLDS A B.S. DEGREE FROM MORGAN STATE UNIVERSITY, AN M.S. DEGREE IN ADMINISTRATION FROM CENTRAL MICHIGAN UNIVERSITY, AND A MASTER OF POLICY MANAGEMENT DEGREE FROM GEORGETOWN UNIVERSITY. HE IS A GRADUATE OF THE ORDNANCE OFFICER BASIC COURSE AND THE COMBINED LOGISTICS CAPTAINS CAREER COURSE.

THE AUTHOR THANKS LIEUTENANT GENERAL (USA, RET.) C.V. CHRISTIANSON, GEORGE TOPIC, LIEUTENANT COLONEL TOM MILLER, AND LIEUTENANT COLONEL DARNELL JONES FOR THEIR ASSISTANCE IN DEVELOPING THIS ARTICLE.

The Road to Interoperability

BY MAJOR SUSAN CARSON, BRITISH ARMY

The United States and the United Kingdom are allies in military operations around the world. In this article, a British officer examines the possibility of true interoperability between the two nations' Armed Forces.

One of the key challenges for allied militaries working together is language. Defining terms, therefore, is fundamental at the beginning of all bilateral or multilateral processes and meetings. Representatives from each of the nations must provide definitions for the words that may not be understood by personnel from the other militaries. Sharing definitions is key to allied interoperability.

Finding a formal definition of interoperability, however, is easier said than done. Most definitions of interoperability focus on coordination and cooperation and ordinarily refer to computer and information systems. In the military, we take interoperability to mean being able to work together with another military and, in its most encompassing form, operating together as one; sharing information, equipment, or even subunits; and exchanging assets with little or no impact on the mission. The narrower definitions do not fit with these military aspirations, though, as we mean more than cooperation and they focus on the technology-related aspects of interoperability that have nothing to do with making it easier to sustain a deployed multinational force.

Interoperability Rock Drill

Despite this lack of clarity in the definition, the United Kingdom and the United States have been developing a logistics interoperability plan over a number of months, exploring what areas, if any, exist in which they can operate together. The work to date culminated in a United Kingdom-United States interoperability review of concept drill, also known as a rock drill, which took place in the United Kingdom in March 2008. The teams from each side of the Atlantic that were involved in the preparation identified four areas of potential interoperability for further exploration: command and control, information management systems, transportation and equipment, and logistics support services.

Binational groups of subject-matter experts were ensconced in separate rooms for a week to see if they could determine where the two countries were already interoperable, which areas were beyond the scope of interoperability, and which areas should be further developed—a somewhat challenging task made even

more challenging because they were not always speaking the same language. (What exactly does “like white on rice” mean, for example?) A plethora of issues were raised and discussed and resulted in the identification of six key areas in which progress could be made.

Command and Control of U.S. and U.K. Units

One potential area for improvement involves the names and structures of our logistics organizations. The U.S. structure includes theater sustainment commands (TSCs), expeditionary sustainment commands (ESCs), and sustainment brigades as opposed to the United Kingdom's joint force logistic component, Army logistic brigades, and logistic and maintenance regiments. The question is how those organizations are best set up to talk to one another and handle tasks and issues. Which one relates to which, and who should talk to whom?

The key difficulty is that, in one sense, the nations' logistics structures are completely different. Logistics in the United Kingdom is a large and increasingly joint activity; in the United States, the services manage logistics individually. This means that none of the organizations has an exact equivalent and two noncomparable organizations will be forced to work in parallel to achieve interoperability. The TSC, for example, is an organization dissimilar to any U.K. establishment and has no obvious counterpart.

On the other hand, rough equivalents of some units do exist, but corresponding posts will not have exactly the same responsibilities, despite some commonality. The joint force logistic component can be aligned to the ESC, and an Army logistic brigade is similar to a sustainment brigade, so interoperability between the units can be made to work. The real challenge is developing a command and control architecture to enable combined planning, decisionmaking, and execution. Performing these functions is essential for true interoperability in the military sense of the word. The rock drill team agreed that some form of joint logistics planning organization, possibly known as the Logistic Coordination Board (LCB), is required. Essentially, the LCB should plan and make decisions, and the ESCs and Army logistic brigades should execute the plan. The

Information Systems Interoperability Framework

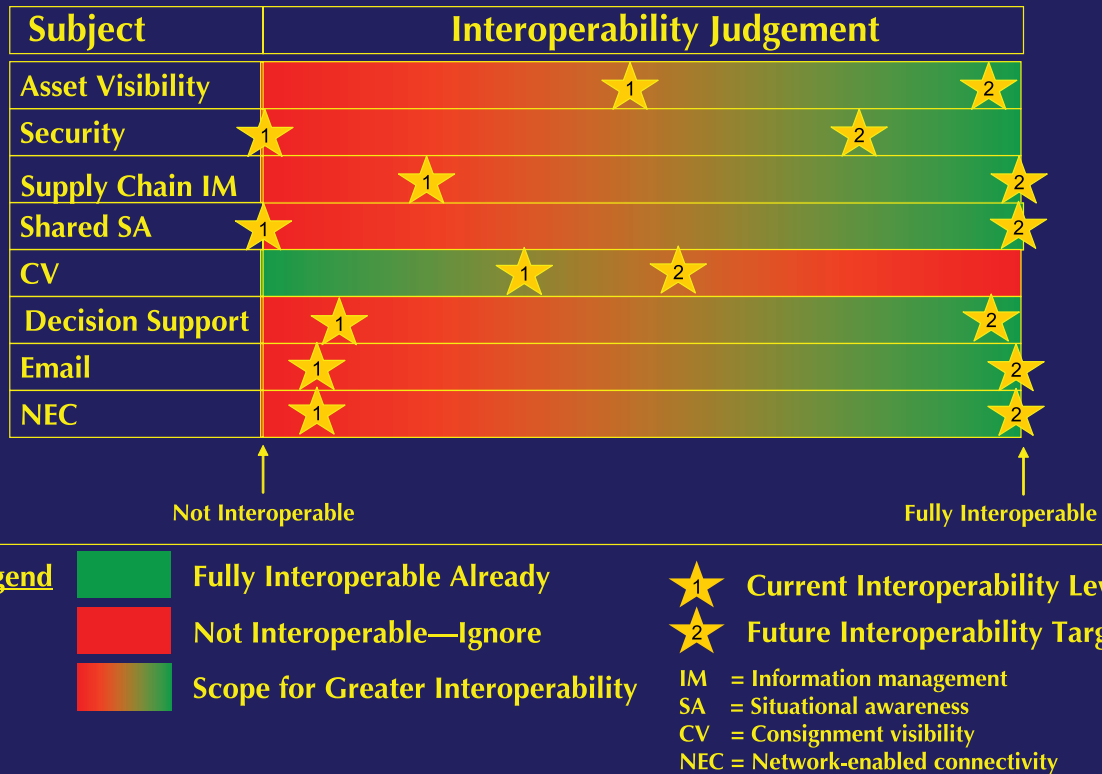

This chart shows some of the areas within U.S. and U.K. information systems that are interoperable or could become more interoperable in the future.

LCB should be part of the Combined Joint Task Force Headquarters, but it is essential that all U.S. and U.K. logistics formations are represented on the board.

Interoperability and Information Systems

Regarding logistics information systems, the rock drill team discovered that a great deal of activity is taking place at the national level to improve logistics information systems under network architectures. While both nations have the same outcome in mind (improved situational awareness, more accurate monitoring of the supply chain, and improved maintenance support), their efforts are taking place in isolation and interoperability has not been factored in to date. Part of the reason for this is the cost of providing such services. Both nations contract out much of their communications technology efforts, and adding interoperability to the equation would significantly increase the cost of the contracts. With financial challenges currently facing both armies, the best that can be achieved realistically is including interoperability in future requirements along with the recognition that such requirements are extremely vulnerable to budgetary pressures.

The sensitivities and limitations of sharing information also need to be acknowledged. Using the North Atlantic Treaty Organization (NATO) systems framework may be one way of achieving initial progress in the planning, rather than the execution, of the campaign. But reluctance to share information through these means can exist, and the information that is shared may be of limited utility. Rock drill participants agreed that a pragmatic approach needs to be adopted and that total interoperability is too ambitious.

Priorities must be set in order to achieve something, and all other elements must become secondarily important or even left as future aspirations. Without setting priorities, some of our current capabilities could actually end up being lost. So on the road to interoperability, having unwittingly taken a step forward, we are in danger of taking a step back. This must change if interoperability is to become reality.

Transportation and Equipment Interoperability

The transportation, movement, equipment, and maintenance areas offer many opportunities for improving coordination, although the improvement will rely on effective command and control and information

systems. True military interoperability is much more difficult, however, when both nations have different equipment, training procedures, legislative requirements, and capabilities. Political imperatives also feature in the execution of any deployment, and relying on another nation to execute part of the plan will always be sensitive. However, logistics interoperability offers real prospects for moving beyond coordination to the full sharing of assets.

Naturally, full asset sharing depends on the operational situation, but asset sharing is a practical way in which interoperability can become a fact rather than a goal. Rock drill participants agreed that an endorsed set of operating procedures will be required as a starting point, followed by the inclusion of logistics support—transportation, movement, equipment, and maintenance—early in the LCB's planning phase. Combined planning, priority setting, and task allocation will be essential. These will be challenging to achieve but are fundamental to becoming truly interoperable.

Logistics Support Services

In the logistics support services area, the rock drill identified myriad opportunities for sharing the supply, distribution, and storage of commodities identified by classes of supply. Some coordinated activity in this area already takes place. For example, NATO has a common fuel policy and the supply of water is shared. Much more work is needed to determine the feasibility of this, but it is another area in which further gains can be made.

The other area that provides real opportunities for progress is contracting. The United States has been doing this very successfully for a number of years, and the United Kingdom can learn much from its experiences. Sharing best practices can be the starting point, although this is arguably cooperation rather than interoperability. Full interoperability could be achieved by using the same contract and by sharing contractors. Opportunities for interoperable contracting may exist in the future and could, in turn, lead to enhanced interoperability in areas such as transportation and movement.

Why Not Interoperability?

One of the key points that came out of the discussions was that not all logistics activities need to be interoperable. For example, in the areas where the two nation's systems are fundamentally different or where they have equipment that is essentially incompatible, no logic exists in trying to achieve interoperability. This leaves two overarching problems. The first is interoperability's practical utility for operations. The second issue is one of depth: is all of this interoperability, or is it just cooperation and coordination?

Practical utility. The key product from the rock drill is the U.S./U.K. Logistics Interoperability Guide, which was used in draft form during the drill as a handrail to aid discussion. The guide has since been amended to include the results of the rock drill, and it was issued in the summer of 2008. The intent is for the guide to be of practical value for operations rather than just a series of theoretical desirables; but is this actually possible? The people who developed the guide certainly have plenty of experience in joint and combined operations, and if those same individuals continue this effort in the future, it could be made to work—particularly if the LCB is established early.

What would increase the likelihood that the first real usage of interoperability will succeed would be placing those individuals in deployed staff headquarters and in the field armies of the two nations the first time interoperability principles are applied. This would be rather difficult to orchestrate, especially because many of the rock drill participants are civilians. Ensuring that interoperability is put into practice will require a serious information and training campaign that could become part of routine training for those who may deploy in the future.

Interoperability versus cooperation. Can we achieve interoperability, or are we limited to cooperation and coordination? If true interoperability is achieved, does it enable us to make U.K. formations subordinate to U.S. formations, for example? (The rock drill looked specifically at a U.K. brigade within a U.S. division and was not aiming to achieve interoperability below that level.) What about using the same facilities in ports or the same staff and transport assets (rather than allocating timeslots for U.K. use and separate periods for U.S. use)? The transport, movement, and maintenance areas could see a real sharing of assets, as could contracting. This would be difficult to achieve, however, without first setting in place overarching command and control structures and information systems.

So the road to interoperability begins with some serious obstacles that require breaching. Progress can be made in other parallel areas, but perhaps interoperability can only truly be achieved within the information systems world and the rest is simply cooperation. That may ultimately be the case, but driving through cooperation to true interoperability, if it can be reached, would definitely be worth the journey. **ALOG**

MAJOR SUSAN CARSON IS A STAFF OFFICER CURRENTLY DEVELOPING LOGISTICS POLICY FOR THE ARMY IN THE UNITED KINGDOM'S MINISTRY OF DEFENCE. SHE HAS A B.A. DEGREE IN HISTORY FROM THE UNIVERSITY OF SWANSEA. MAJOR CARSON WAS APPOINTED A MEMBER OF THE BRITISH EMPIRE IN HER MAJESTY THE QUEEN'S NEW YEAR'S HONOURS LIST IN 2004 FOR HER ROLE IN THE DEPLOYMENT OF BRITISH TROOPS TO IRAQ.

Army Logistics Knowledge Management and SALE

BY DR. NICHOLAS J. ANDERSON

This article, the first in a three-part series, introduces the author's research of Army logistics knowledge management and the Single Army Logistics Enterprise.

The Single Army Logistics Enterprise (SALE) is a network of automated logistics information systems. Information technology (IT) hardware and software plug into the SALE architecture to help the Army maintain warfighting readiness. SALE provides visibility over the logistics pipeline to managers at all levels of operations through a web-based, integrated logistics database. The Army has identified SALE's logistics functional areas as supply, maintenance, ammunition management, and distribution.

SALE is the Army's logistics enterprise system. The vision for SALE is "a fully integrated knowledge environment that builds, sustains, and generates warfighting capability through a fully integrated logistics enterprise based upon collaborative planning, knowledge management, and best business practices."¹ The three components of SALE are collaborative planning, best business practices, and knowledge management (KM). However, the Army has not identified the logistics KM practices that SALE should support.

The Problem

The Army does not have a logistics KM framework to help manage data and information from SALE. To compound the problem, the Army has not taken steps to identify SALE implementation procedures relative to logistics KM. This presents a danger that the ongoing implementation of SALE might not be relevant to Army logistics KM. Current Army logistics policies and regulations do not address KM and its relationship with SALE.

Army logisticians need to know how to manage data and information. According to Donald Hislop,

"Data includes numbers, words and sounds which are derived from observation or measurement, and information represents data arranged in a meaningful pattern . . . Knowledge can be understood to emerge from the application, analysis, and productive use of data and/or information."² KM pertains to the discovery, sharing, and application of knowledge.³

Unlike in the past when logisticians relied primarily on data and information from stovepiped stand-alone systems, today's logisticians deal with real-time data and information from enterprise systems like SALE to manage the logistics pipeline. Recent IT breakthroughs and Army transformation require the Army logistics community to identify KM requirements and implement KM practices to satisfy the requirements. Otherwise, the flood of data and information from an enterprise system like SALE could overwhelm logisticians.

The Research

The purpose of this research is to propose a logistics KM framework and examine the implementation of SALE to determine its relevance to Army logistics KM. The relationship between Army logistics KM and SALE should evolve from logistics KM requirements, logistics KM practices, and SALE implementation efforts.

Many Army documents and KM studies were examined to help determine Army logistics requirements. Petrides and Guiney's study⁴ about KM and organizational strategies and Smith and McKeen's study about the importance of an organizational vision for KM⁵ and business processes⁶ provided insights for this portion of the research, as did Grossman's study⁷ about KM metrics and academic discipline.

¹ Enterprise Integration, Inc., "Single Army Logistics Enterprise: Overall Army Logistics Enterprise Solution Report-Final," Fairfax, Virginia, 2003.

² Donald Hislop, *Knowledge Management in Organizations*, Oxford University Press, New York, 2005.

³ I. Becerra-Fernandez and R. Sabherwal, "ICT and Knowledge Management Systems," *Encyclopedia of Knowledge Management*, Idea Group Reference, Hershey, Pennsylvania, 2006, p. 230-234.

⁴ Lisa A. Petrides and Susan Zahra Guiney, "Knowledge Management for School Leaders: An Ecological Framework for Thinking Schools," *Teachers College Record*, Vol. 104, No. 8, 2002, p. 1702-1717.

⁵ Heather A. Smith and James D. McKeen, *The Evolution of the KM Function*, May 2003, <http://business.queensu.ca/centres/monieson/docs/working/working_03-07.pdf>, accessed on 26 September 2007.

⁶ Heather A. Smith and James D. McKeen, "Developments in Practice XII: Knowledge-Enabling Business Processes," *Communications of the Association for Information Systems*, Vol. 13, 2004, p. 25-38.

⁷ Martin Grossman, "An Overview of Knowledge Management Assessment Approaches," *The Journal of American Academy of Business*, Vol. 8, No. 2, March 2006, p. 242-247.

According to Miles and Huberman, “when you’re working with text or less organized displays, you often note recurring patterns, themes, or ‘gestalts,’ which pull together many separate pieces of data. Something ‘jumps out’ at you, suddenly makes sense.”⁸ Strategies, policies and regulations, institutional training and education, and operations drive Army logistics KM requirements. These themes that emerged from analyzing Army documents and KM studies helped to identify Army logistics KM requirements.

The strategies that were studied included enhanced capabilities, network-centric warfare (NCW), and best business practices. The policies and regulations included standards and goals. Institutional training and education included policies and programs provided by the Army Training and Doctrine Command (TRADOC), the Army Combined Arms Center (CAC), and the Army Combined Arms Support Command (CASCOM). Operations included strategic, operational, and tactical logistics.

Strategies

The strategies that influence Army logistics KM requirements include the 2004 Army Transformation Roadmap, the Army Knowledge Management (AKM) Strategy, and the 2006 Army Game Plan.

The Army Transformation Roadmap “refines the Army’s transformation strategy and details Army actions to identify and build required capabilities to enhance execution of joint operations by the Current Force while developing the capabilities essential to provide dominant land-power capabilities to the future Joint Force.”⁹ AKM “is the Army’s strategy to transform itself into a network-centric, knowledge-based force and an integral part of the Army’s transformation to achieve the Future Force.”¹⁰ The 2006 Army Game Plan “describes strategic challenges and reinforces the centrality, importance, and intent of the Army Campaign Plan.”¹¹

These strategies provide Army-level guidance for current and future military capabilities. The Army Transformation Roadmap, the AKM Strategy, and the Army 2006 Game Plan help drive Army logistics KM requirements. They contain the Army’s intent for collecting, sharing, and using information. They serve as guides to help the Army become a knowledge-based force. The strategies focus on enhanced capabilities, NCW, and best business practices.

Enhanced capabilities. Strategies that will lead to enhanced capabilities pertain to making decisions, distributing supplies and services, receiving forces, and integrating the supply chain. According to the AKM Strategy, “AKM is intended to improve decision dominance by our warfighters and business stewards—in the battle space, in our organizations, and in mission processes.”¹² Logisticians make decisions with data and information from several knowledge bases. The 2004 Army Transformation Roadmap states:

To sustain combat power, the Army must have the ability to see the requirements through a logistics data network. The Army requires a responsive distribution system enabled by in-transit and total asset visibility and a single owner with positive, end-to-end control in the theater. The Army needs a robust, modular force-reception capability—a dedicated and trained organization able to quickly open a theater and support continuous sustainment throughout the joint operations area. The Army needs an integrated supply chain that has a single proponent that can reach across the breadth and depth of resources in a joint, interagency and multinational theater.¹³

The enhanced capabilities mentioned in the AKM Strategy and the 2004 Army Transformation Roadmap stress the importance of collecting, sharing, and using data and information to make speedy and timely decisions. The Army relies on real-time data and information to conduct operations, and logisticians make decisions concerning the deployment and sustainment of military forces that could affect military operations. Therefore, logisticians must have the capability to make speedy and timely decisions.

NCW. One focus of the Department of Defense’s (DOD’s) transformation efforts is NCW. Alberts, Garstka, and Stein’s study¹⁴ concerning influences of IT on commercial business practices helped launch DOD’s NCW concept. According to their study, NCW is a concept for connecting decisionmakers to achieve situational awareness on the battlefield. IT has revolutionized military operations, and it has also affected Army logistics.

NCW “leverages information-age concepts in the evolving strategic environment, enabling dispersed operations that produce coherent, mass effects via speed and coordinated efforts.”¹⁵ The U.S. Armed Forces implement transformation efforts from an NCW

⁸ Matthew B. Miles and A. Michael Huberman, *Qualitative Data Analysis*, Sage, Thousand Oaks, California, 1994.

⁹ Department of the Army, “Army Transformation Roadmap,” Secretary of the Army, Washington, DC, 2004, p. i.

¹⁰ Department of the Army, Army Regulation 25-1: *Army Knowledge Management and Information Technology*, Department of the Army, Washington, DC, 2005, p. 2.

¹¹ Department of the Army, “Army Game Plan,” Secretary of the Army, Washington, DC, 2006, p. i.

¹² Department of the Army, “Army Knowledge Management Guidance Memorandum Number 1,” Secretary of the Army, Washington, DC, 2001, p. 1.

¹³ Department of the Army, “Army Transformation Roadmap,” Secretary of the Army, Washington, DC, 2004, p. 5–10.

¹⁴ David S. Alberts, et al., *Network Centric Warfare: Developing and Leveraging Information Superiority*, Department of Defense Command and Control Research Program, Washington, DC, 1999.

¹⁵ Department of Defense, “The Implementation of Network-Centric Warfare,” Office of Force Transformation, Washington, DC, 2004, p. 2.

perspective. The Army logistics community must be able to operate in an NCW environment. Furthermore, DOD has identified NCW as a concept that will help transform information sharing. "Achieving the full potential of net-centricity requires viewing information as an enterprise asset . . . As an enterprise asset, the collection and dissemination of information should be managed by portfolios of capabilities that cut across legacy stove-piped systems."¹⁶ The Army must have the means to access and share information in an NCW environment. The logistics piece of this pertains to logistics KM requirements. Logisticians must access and share data and information in an NCW environment.

Best business practices. The AKM Strategy and the 2006 Army Game Plan cover best business practices. The AKM Strategy emphasizes "innovative ways of doing business to improve Army decision making and operations."¹⁷ It states that decisionmakers must "integrate best business practices into Army processes to promote the knowledge-based force."¹⁸ The 2006 Army Game Plan says that the Army should concentrate on core missions and processes and on measuring performance.¹⁹

For the Army logistics community, this means focusing on core logistics functions and measuring the performance of the execution of those functions. Logisticians quantify data and information in order to measure the performance of logistics processes. The 2006 Army Game Plan advocates the Lean Six Sigma management technique to measure improvements in processes. Logisticians use performance-measurement approaches like Lean Six Sigma to determine how well logistics processes are performing.

Best business practices help drive Army logistics KM requirements. Best business practices, NCW, and enhanced capabilities support the vision of the Army logistics community for collecting, sharing, and using data and information. These strategies could help the Army logistics community identify logistics KM requirements and influence policies and regulations.

Policies and Regulations

Although the Army has over 100 Army regulations (ARs), field manuals (FMs), and pamphlets covering logistics, the main documents that influence Army logistics KM requirements are FM 4-0, Combat Service Support; FM 3-0, Operations; AR 220-1, Unit Status

Reporting; AR 700-138, Army Logistics Readiness and Sustainability; and AR 25-1, Army Knowledge Management and Information Technology. FM 4-0 is the authoritative doctrine for sustainment, and FM 3-0 is the Army's keystone doctrine for full-spectrum operations. AR 220-1 covers "the readiness of Army units for their wartime mission,"²⁰ and AR 700-138 assigns responsibilities and establishes policies and procedures for reporting the condition of Army equipment. AR 25-1 establishes policies and responsibilities for information management and information technology. These regulations identify goals and standards.

AR 700-138 provides materiel readiness goals for the Army. Logisticians manage data and information pertaining to supply, maintenance, production, distribution, and other logistics support needed to attain materiel readiness goals. AR 25-1 identifies the Army's web portal, called Army Knowledge Online (AKO), as an AKM goal for the Army. AR 25-1 states that the Army should "institutionalize AKO as the enterprise portal to provide universal, secure access for the entire Army."²¹ For the Army logistics community, AKO's institutionalization as the enterprise portal implies that logisticians must use AKO to access, share, and apply logistics data and information. Logisticians use AKO to help ensure that the right supplies and services get to the right place at the right time and to ensure equipment readiness standards.

Institutional Training and Education

Army institutional training and education programs include requirements for collecting, sharing, and using logistics data and information. However, many programs do not have updated courses that use the term "logistics KM requirements." The Army institutions that drive logistics KM requirements include TRADOC, CAC, and CASCOM, which all provide oversight over logistics training and leader development.

TRADOC "recruits, trains and educates the Army's Soldiers; develops leaders; supports training in units; develops doctrine; establishes standards; and builds the future Army."²² TRADOC provides overarching policies for training and educating Soldiers. CAC and CASCOM develop and execute training and education programs in support of TRADOC policies.

CAC provides policies pertaining to officer, non-commissioned officer, and civilian education. CAC focuses on the professional development of leaders.²³

¹⁶ Department of Defense, "Quadrennial Defense Review Report," Secretary of Defense, Washington, DC, 2006, p. 58.

¹⁷ Department of the Army, "Army Knowledge Management Guidance Memorandum Number 1," Secretary of the Army, Washington, DC, 2001, p. 1.

¹⁸ Department of the Army, *Army Regulation 25-1: Army Knowledge Management and Information Technology*, Department of the Army, Washington, DC, 2005, p. 2.

¹⁹ Department of Defense, "Quadrennial Defense Review Report," Secretary of Defense, Washington, DC, 2006.

²⁰ Department of the Army, *Army Regulation 220-1: Unit Status Reporting*, Secretary of the Army, Washington, DC, 2006.

²¹ Department of the Army, *Army Regulation 25-1: Army Knowledge Management and Information Technology*, Department of the Army, Washington, DC, 2005, p. 2.

²² "TRADOC Mission," Training and Doctrine Command, 2007, <<http://www.tradoc.army.mil/about.htm>>, accessed on 27 July 2007.

²³ "Core Functions Leader Development and Education," Combined Arms Center, 2007, <<http://usacac.army.mil/CAC/leaderdevelopment.asp>>, accessed on 8 August 2007.

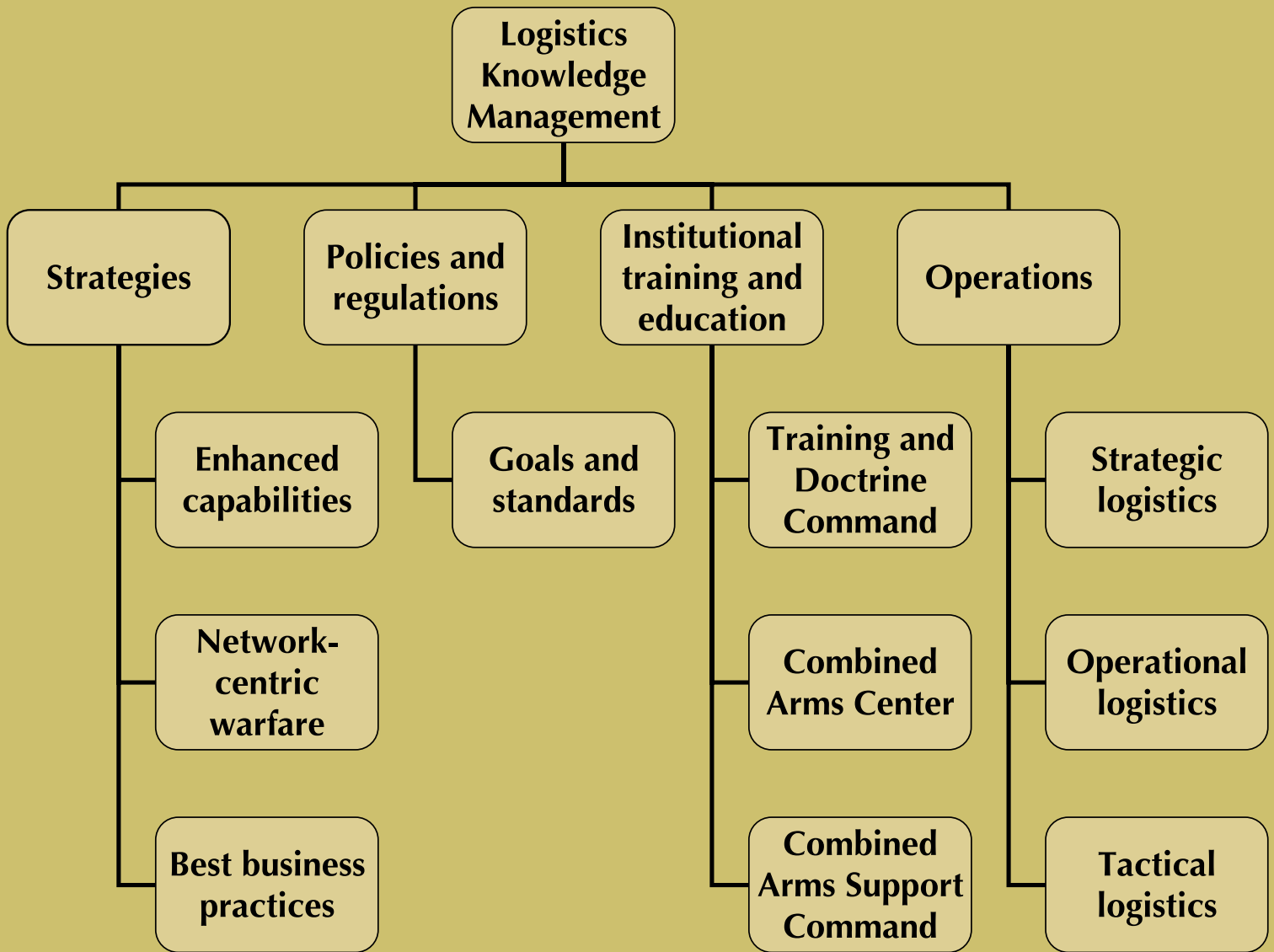

This chart shows the relationship of Army logistics knowledge management to strategies, policies and regulations, institutional training and education, and operations.

CASCOM operates the logistics branch schools (Quartermaster, Ordnance, and Transportation), writes logistics doctrine, provides an Army-wide construct for organizing logistics forces, and ensures that logistics materiel solutions support warfighting.²⁴ According to the CASCOM Command Overview Briefing and information from the Quartermaster, Ordnance, and Transportation schools, the Army does not have logistics KM courses. However, existing logistics training and education programs address collecting, sharing, and using logistics data and information. The Army simply has not created logistics KM requirement titles for what it trains and educates. Logisticians who need specific logistics KM requirements training and education attend special courses at their respective training and education centers.

CAC and CASCOM have the institutional structure for training and educating personnel in logistics KM requirements. According to the CAC approach to KM, the Army logistics community should view KM from the perspectives of the institutional and operational forces. So CAC has instituted a web-based KM forum, called Battle Command Knowledge System (BCKS), to help collect, share, and use knowledge. CASCOM has launched a similar web-based logistics forum, called LOGNet, as a subordinate function of BCKS.

The Army's training and education institutions influence logistics KM requirements. Since the Army has not updated logistics doctrine with KM terminologies, existing training and education programs do not describe the collection, distribution, and use of logistics data and information as KM. However, the training

²⁴ "Command Overview Briefing," Combined Arms Support Command, 2007, <http://www.cascom.army.mil/cmd_plan_group/CASCOM%20Overview%20Briefing-net.ppt>, accessed on 8 July 2007.

and education that logisticians receive include logistics KM requirements. LOGNet helps logisticians collect, share, and use data and information. KM training and education occurs for all levels of operations.

Operations

Army strategic, operational, and tactical levels of operation influence logistics KM requirements. The logistics operations KM driver focuses on capacity management of the logistics pipeline at the strategic, operational, and tactical levels. Logisticians moderate the flow of data and information at these levels of operations. The Army logistics capstone document, FM 4-0, states—

Capacity management operations focus on programming changes in the system infrastructure to modify the finite capacity of the distribution system. Capacity management deals with balancing distribution system capacity against evolving changes in theater support requirements. Distribution managers plan for bottlenecks, disruptions, and changes in the operational scheme in order to optimize a theater's distribution capacity. Capacity management operations use visibility and control to anticipate distribution needs, provide the necessary resources at the right time, monitor execution, and, as necessary, adjust the distribution system to avoid distribution problems.

Army logistics KM requirements consist of a combination of data and information for managing the logistics pipeline at the strategic, operational, and tactical levels. Logistics KM requirements evolve from logistics data and information from the following areas—

- Subsistence and water.
- Troop support materiel.
- General supplies.
- Clothing and textiles.
- Industrial supplies.
- Packaged and bulk petroleum.
- Barrier and construction materials.
- Ammunition.
- Personal demand items.
- Major end items.
- Medical materiel.
- Repair parts.
- Mail.
- Line-haul movements.
- Maintenance.
- War reserves.²⁵

Strategic logistics. The “strategic level is that level at which a nation, often as one of a group of nations, determines national and multinational security objectives and guidance, and develops and uses national resources

to accomplish them.”²⁶ Strategic logistics KM requirements include the identification, collection, dissemination, and use of data and information to deploy forces and sustain them with supplies and services from the U.S. and international industrial bases. A combination of institutional and operational organizations provides strategic-level support. Examples of strategic-level logistics support include the distribution of supplies from pre-positioned stocks around the world, transportation of materiel and personnel, and coordination of repairs at Army maintenance depots.

Operational logistics. “The operational level is the level at which campaigns and major operations are conducted and sustained to accomplish strategic objectives within theaters or areas of operation.”²⁷ Operational logistics KM requirements include the management of data and information to bridge the interface between the strategic and tactical levels.

Tactical logistics. “The tactical level is the realm of close combat, where friendly forces are in immediate contact and use direct and indirect fires to defeat or destroy enemy forces and to seize or retain ground.”²⁸ Tactical-level logistics KM requirements include the management of fuel, ammunition, food, repair parts, and other materiel to ensure the right support gets to the warfighter at the right time and right place.

Logisticians manage the logistics pipeline for logistics functions. Army logisticians focus their efforts on supporting strategic, operational, and tactical logistics operations. Operations at these levels drive logistics KM requirements. Logisticians focus on the capacity of the logistics pipeline to ensure uninterrupted support to all levels of military operations.

Since the Army does not have a framework for identifying logistics KM drivers—strategies, policies and regulations, training and education, and operations—the KM drivers suggested by this research could assist Army logisticians with these efforts. The Army logistics community must get its arms wrapped around logistics KM requirements. Otherwise, the ongoing implementation of SALE might not be relevant to Army logistics KM.

ALOG

DR. NICHOLAS J. ANDERSON IS THE PRESIDENT OF O&M CONSULTING, LLC, IN GOOSE CREEK, SOUTH CAROLINA. HE IS A RETIRED ARMY COLONEL AND A GRADUATE OF SOUTH CAROLINA STATE UNIVERSITY. HE HAS A DOCTOR OF PHILOSOPHY DEGREE IN ORGANIZATION AND MANAGEMENT FROM CAPELLA UNIVERSITY, A MASTER'S DEGREE IN MANAGEMENT FROM WEBSTER UNIVERSITY, AND A MASTER'S DEGREE IN STRATEGIC STUDIES FROM THE ARMY WAR COLLEGE.

²⁵ Department of the Army, “Army Knowledge Management Guidance Memorandum Number 1,” Secretary of the Army, Washington, DC, 2001, p. 1.

²⁶ Department of the Army, *Field Manual 4-0: Combat Service Support*, Secretary of the Army, Washington, DC, 2003, p. 4-1.

²⁷ *Ibid.*, p. 4-1.

²⁸ *Ibid.*, p. 4-12.

Operational Logistics Planner for the Modular Army

BY THOMAS W. CHAVERS

The newest update of the Operational Logistics Planner incorporates the Modular Army organization into the planning system.

Logistics planners now have an easy tool for completing logistics estimates. The Army Combined Arms Support Command (CASCOM) Planning Data Branch (PDB) has released Operational Logistics (OPLOG) Planner 7.0. CASCOM has refined the OPLOG Planner into a premier planning tool specifically designed to support operations typically associated with plans and orders for multiphase operations.

Those who have not used OPLOG Planner recently will notice a number of changes. Recent upgrades enable the interactive tool to quickly determine which logistics supplies planners will need to support operations. The new OPLOG Planner has more user-friendly menus and queries and includes extensive help features.

OPLOG Planner enables users to estimate mission requirements for water, ice, mail, and all classes of supply (except material to support nonmilitary programs [class X]), using the latest modular force structures and planning rates approved by the Deputy Chief of Staff, G-4, Department of the Army. No other planning tool gives users this Army-approved and updated logistics estimate planning data.

OPLOG Planner allows the user to build multiple task organizations by using a preloaded list of units and equipment or by importing custom-built units that the user has created from scratch. OPLOG Planner assigns each task organization a consumption parameter set. A consumption parameter set establishes the rates, climate, joint phases (deter, seize initiative, or dominate) and Army operations (offense, defense, stability, or mission staging) necessary for the mission. The planner can use predefined default planning rates or customize rates based on unit experiences. These consumption parameter sets and task organizations form an order. OPLOG Planner generates the logistics supply requirements that users can view for the entire operation, by operational phase, by task organization, by unit, or by individual unit equipment. Users can print logistics requirement reports in Microsoft Word or export reports to Microsoft Excel for further analysis.

Users can save orders for recall and later use in course-of-action analysis. For example, if the user wants to estimate the fuel consumption of an infantry brigade combat team (IBCT) with an attached armor

company in an offensive dominate operation, the user would select the IBCT and the armor company and place them in the same task organization. In a couple of minutes, the user will have the projected fuel requirement for the mission. In addition, a unit preparing to deploy to a theater can forecast supply requirements from the initial staging area to the final destination and then for its first phase of operation.

At least annually, CASCOM updates OPLOG Planner with current force structure and rate changes, including the effect of up-armorings or revised equipment usage profiles on fuel usage. The CASCOM PDB provides additional updates based on user needs and suggestions, so users should check back regularly for the most current version. Planned future upgrades include the addition of a casualty estimator for medical calculations, a transportation analysis module, and expansion of the ammunition (class V) rates module.

In addition to OPLOG Planner 7.0, PDB has developed several Microsoft Excel workbooks to assist the Army in the field with estimations of requirements for specific classes of supply. Users can find estimation and other planning tools for food and water, construction materials, and barrier-fortification supplies on the Internet at <https://www.cascom.army.mil/private/CDI/FDD/Multi/PDB/EstimationTools.htm>. A platform calculator and a master standard requirement code query are also available.

Users can download OPLOG Planner from the CASCOM PDB webpage. The Internet Protocol address is <https://www.cascom.army.mil/private/CDI/FDD/Multi/PDB/OPLOGPLANNER.HTM>. The PDB is looking for feedback on the tool, so try it out and let us know what you think. Users can email OPLOG Planner support with questions and comments about OPLOG Planner 7.0 at leeOPLOGPLN@conus.army.mil. **ALOG**

THOMAS W. CHAVERS IS THE DATABASE MANAGER FOR THE ARMY COMBINED ARMS SUPPORT COMMAND, LOGISTICS PLANNING DATA BRANCH, AT FORT LEE, VIRGINIA. HE HAS A MASTER'S DEGREE IN CHEMICAL ENGINEERING FROM THE UNIVERSITY OF SOUTH ALABAMA AND IS A GRADUATE OF THE OPERATIONS RESEARCH AND SYSTEMS ANALYSIS MILITARY APPLICATIONS COURSE.

R&R: Reading and Reviews

In this issue, Army Logistician is launching a new department—a book review column for logisticians we call “R & R: Reading and Reviews.” If you have read a logistics-related book that you would like to review for your peers, contact us for more information at leeelog@conus.army.mil. Please do not send us a review until you have talked to us. We look forward to hearing from you.

—Editor

The Opposable Mind: How Successful Leaders Win Through Integrative Thinking. Roger L. Martin. Harvard Business School Press, Cambridge, Massachusetts, 2007, 224 pages.

In 2007, *Harvard Business Review* published “How Successful Leaders Think” by Roger Martin. The article, a preview of his forthcoming book, *The Opposable Mind*, was widely acclaimed. This praise was not surprising given Martin’s credentials: He received the Marshall McLuhan Award for Visionary Leadership in 2003, and he was one of *BusinessWeek*’s seven “Innovation Gurus” in 2005. Two years later, the same magazine selected him as one of the 10 most influential business professors in the world. Martin, currently dean of the management school at the University of Toronto, is no naive intellectual but a graduate of the Harvard master’s in business administration program and an entrepreneur who helped grow Monitor Company from a startup to a global strategy-consulting firm. *The Opposable Mind* deserves an award as well; it is a superb blend of theory and professional practice that makes it a profitable read for any leader by contributing to our understanding of how leaders should think about their craft.

Martin’s book begins with a simple premise captured by American novelist F. Scott Fitzgerald in his 1936 essay, “The Crack-Up.” “The test of a first-rate intelligence,” Fitzgerald wrote, “is the ability to hold two opposed ideas in the mind at the same time, and still retain the ability to function.” Martin argues that this ability should not belong solely to geniuses but also to leaders. He bases his argument on his interviews and analysis of more than 50 leaders of corporations and non-profit organizations, from Proctor and Gamble to the Toronto International Film Festival—a group diverse in age, gender, and other characteristics.

The key insight Martin gained from this expansive study was that, simply put, highly successful leaders do not think like most of their counterparts. The common element is their refusal to accept tradeoffs between two options—“either/or thinking.” Instead, they use “integrative thinking,” which Martin defines as “the ability to face constructively the tensions in opposing ideas and, instead of choosing one at the expense of the other, generate a creative resolution of the tension in the form of a new idea that contains elements of the opposing ideas but is superior to each.”

Martin does not belittle contemporary management theorists who have uncovered the components of successful organizations (ones that favor a bias for action). He would never dispute the importance of “doing,” but he also believes that a leader’s thinking makes the difference. Effective leaders, he contends, have a bias for thinking first. He also has no objection to studying the careers of business giants such as General Electric’s Jack Welch, whom he interviews, but he cautions that the context in which a particular leader attains success will not necessarily translate directly to the situation another leader confronts.

Refreshingly, Martin readily admits that integrative thinking is neither a necessary step for success nor a cure-all. What he offers is more lasting and valuable, particularly for logisticians who seek leadership success at the highest level of command and government. It is a disciplined way of thinking through the knotty problems leaders confront and will likely improve their chances of organizational achievement. His motto for leaders might be, “Think harder.”

Martin explains integrative thinking by examining decisionmaking, the leader’s ultimate responsibility. He breaks the decisionmaking process into four steps: determining salience, analyzing causality, evaluating the decision architecture, and achieving resolution.

The first step is not to focus on only the obvious features relevant to making a decision, but to search for the less obvious ones. The leader must be willing to leave his comfort zone and tolerate “messy,” “complex,” and “chaotic” challenges—not eliminate issues or problems because they are distressing. Second, the leader should test the relationship between cause and effect. Third, the leader should not examine a problem in a linear fashion or by breaking it into pieces to solve separately; instead, he should examine it holistically. Here logisticians will find Martin’s example particularly apt as he describes the link between transportation systems and supply distribution—a concrete example of how pieces fit together and influence one another. Fourth, to achieve resolution, the leaders must set high standards that block the acceptance of for-or-against results and instead opt for creative solutions.

The final chapter of Martin’s book is a short course on creating a personal knowledge system. By integrating stance (that is, how you perceive the world around you and your role in it), tools such as formal theories

and rules of thumb, and experience, a leader can learn to think strategically. This is an essential competency for logisticians leading organizations in the current operational environment that remains volatile, complex, and uncertain.

FRANK L. JONES IS A PROFESSOR OF SECURITY STUDIES AT THE ARMY WAR COLLEGE AT CARLISLE BARRACKS, PENNSYLVANIA.

A Devotion to Duty: Memoirs of General Jimmy D. Ross. Jimmy D. Ross (USA, Ret.), Dr. Mary Magee, Dr. William Moye, et al. Historical Office, U.S. Army Materiel Command, Fort Belvoir, Virginia, 2007, 367 pages.

If one is going to begin a series of works, it is sometimes best to start easy. *A Devotion to Duty* is one of those uncomplicated starts. It is written with an informal style that draws the reader along. The narrative from birth to commissioning serves to tell us that the subject, General Jimmy D. Ross, a former commander of the Army Materiel Command, was once an average kid who entered the Army for any number of reasons. The journey from lieutenant to major reflects a steep learning curve and an unusual assignment pattern.

By the time Jimmy Ross was a major, he had enjoyed 2 years with the 14th Infantry Regiment at Schofield Barracks, Hawaii. Then, according to the practices then prevailing, he transferred into the Transportation Corps, only to be shifted to a 9-month detail to Task Force Air Cobra—a semisecret Southeast Asia Treaty Organization (SEATO) operation in Thailand—to evaluate its potential to host a large U.S. force. As the Nation struggled through civil rights trials and the Kennedy assassination, Ross was off to Vietnam for 1964 and 1965 as a battalion adviser—infantry battalion, that is.

The logistician in Ross began to emerge as he was assigned to the U.S. Strike Command's J-4 Directorate. In that position, he participated in many exercises as well as several Operation Garden Plot deployments. [Garden Plot is the Department of the Army Civil Disturbance Plan, the generic operations plan for military support to domestic civil disturbances.]

Ross returned to Vietnam in June 1969, this time to serve as the 101st Airborne Division Support Command S-4, 1 month after the Battle of Hamburger Hill. At this point in the book, logisticians should slow the page turning and pay close attention. While the style remains informal, lessons can be learned in almost every paragraph. On page 131, Ross describes how he and a group of friends analyzed affairs (as they happened) and applied their experiences to get the mission right the next time. One particular episode revolved around putting contractors on the battlefield, a practice

implemented years later, resulting in huge savings in time and expense. Jerked out of the S-4 position to become the commander of the 10th Transportation Battalion (as a major), Ross found himself in charge of a 1,300-person cargo-handling outfit that included some of Secretary of Defense Robert McNamara's "Project 100,000" Soldiers (with port security as an additional duty).

Then came Ross's time in the Pentagon and his selection as a staff officer for the Chief of Staff of the Army. Here we see the beginnings of the rebuilding of a damaged Army, specifically the establishment of the Army Materiel Command. Ross passes over these periods quickly and superficially, only pausing to recognize the friendships formed, which became critical in latter years.

By the time Ross became a brigadier general and assumed command of the 2d Support Command (Corps), VII Corps, the reader will find logistics issues taking on more definition, addressing how to actually provide corps support with insufficient storage facilities, communications, pipelines, heavy equipment transporters, and bodies to perform the requisite labor. While the solutions portrayed here are unique to U.S. Army Europe in the 1980s, they are indicative of just how far out of the box one may have to go at times to come up with viable solutions.

Moving from Europe back to the Pentagon, Ross became the Deputy Chief of Staff for Logistics, Department of the Army, which forced him to confront measures to compensate for the programmed elimination of 10,000 cooks from the Army ranks. Ross worked with General Robert W. Sennewald, a respected former field commander, to address acceptability issues.

The next issue Ross addressed was ugly new uniforms—BDUs [battle dress uniforms], insulated boots, "unprofessional and slovenly" raincoats, ribbons on the original flimsy green shirt, and belted versus not-belted uniforms. In retrospect, it was an amusing but hugely emotional time. Here we learn that Army Chief of Staff General Carl E. Vuono brought up the idea of resurrecting the beret and alerted the Army staff to the magnitude of the 1989 downsizing decision. This entire section is loaded with the business of doing business inside the Army and is enormously instructive.

All military readers will readily identify with stories that provide snappy reviews of major logistics issues confronting the Army from the mid-1980s to General Ross's retirement, with life stories and professional lessons interlaced throughout. In short, this is an easy to read, very instructive insight into the world of Army logistics from the Vietnam War to Operation Desert Storm and slightly beyond.

DOUGLAS V. JOHNSON IS A PROFESSOR OF NATIONAL SECURITY AFFAIRS AT THE ARMY WAR COLLEGE STRATEGIC STUDIES INSTITUTE AT CARLISLE BARRACKS, PENNSYLVANIA.

ALOG NEWS

LOGISTICS UNITS MOVE AS PART OF BASE CLOSURE AND REALIGNMENT IN EUROPE

Organizational changes and relocations in U.S. Army Europe (USAREUR) will affect a number of logistics units. The 2009 transformation plan will inactivate the 1st Armored Division Support Command in Wiesbaden, Germany, and move the 405th Army Field Support Brigade headquarters and its associated logistics assistance representatives from Seckenheim, Germany, to Kaiserslautern, Germany. Also moving to Kaiserslautern will be the 409th Contracting Support Brigade, the Civilian Human Resources Agency-Europe Region, and the Army Contracting Command, which are now located at Seckenheim. The Regional Contracting Office and 635th Movement Control Team will move from Wiesbaden to Kaiserslautern. The 720th Ordnance Company in Mannheim, Germany, will convert to a modular company. The 109th Transportation Company and the 606th Movement Control Team from Mannheim will return to the United States, as will the 495th Movement Control Team from Vicenza, Italy.

The headquarters of the 7th Army Reserve Command in Kaiserslautern will convert to the 7th Civil Support Command.

These logistics changes are part of the larger conversion of USAREUR headquarters to the 7th Army headquarters. The deployable field Army headquarters will be capable of expeditionary full-spectrum operations and command and control while it continues to serve as the Army service component command of the U.S. European Command. The unit will relocate from Heidelberg, Germany, to Stuttgart, and V Corps headquarters in Heidelberg will inactivate.

USAREUR will tentatively complete realignment in the 2012 to 2013 timeframe if no further modifications are made to the transformation plans.

CONSEQUENCE MANAGEMENT RESPONSE FORCE ASSIGNED TO NORTHERN COMMAND

The first of three Department of Defense CBRNE [chemical, biological, radiological, nuclear, and high-yield explosive] Consequence Management Response Forces (CCMRFs) is ready to respond in support of U.S. domestic operations or disasters. The unit of 4,700 joint personnel was stood up on 1 October. According to Air Force General Gene Renuart, commanding general of the U.S. Northern Command (NORTHCOM), this CCMRF is trained, organized, equipped, and has sufficient command and control to respond to large scale CBRNE events within 48 hours.

The CCMRF's capabilities include search and rescue, decontamination, medical, aviation, communications, and logistics support. Each team will have three task forces—operations, medical, and aviation—that have their own operational focus and skill sets. While civilian consequence managers will lead the way in responding to a domestic emergency, the CCMRF is the military's response. The team is training with first responders and the Federal Emergency Management Agency to ensure integrated support.

In order to shorten response time to authorize the use of a CCMRF in a homeland emergency, the units will report directly to NORTHCOM at Peterson Air Force Base, Colorado. Though the first CCMRF is a joint unit, it falls under the operational control of NORTHCOM's Joint Land Force Component Command, U.S. Army North, in San Antonio, Texas.

Soldiers from the 1st Battalion, 32d Iraqi Army Brigade, push a high-mobility multipurpose wheeled vehicle off a flatbed trailer before beginning a 3-day project, nicknamed "Grease Monkey," designed to improve the skills of Iraqi Army maintenance personnel. During the project, mechanics from Company B, 589th Brigade Support Battalion, taught the Iraqi Army mechanics how to inspect their vehicles and provided equipment needed to conduct maintenance. (Photo by SGT Daniel T. West, 41st Fires Brigade Public Affairs)



ARMY FORCE GENERATION DOMINATES DISCUSSION AT AUSA MEETING

Army Force Generation (ARFORGEN) was a key topic in the discussions concerning modular unit readiness at the Association of the United States Army annual meeting and exposition, held 6 to 8 October in Washington, D.C.

During the session on "Enterprise Logistics," Lieutenant General Ann E. Dunwoody, deputy commanding general of the Army Materiel Command (AMC), said that AMC has two key missions driving it in regards to ARFORGEN: providing support that is more effective to operational units and meeting the imperatives given by the Chief of Staff of the Army, General George Casey, to sustain, prepare, reset, and transform the force.

To accomplish these missions, AMC has three Army field support brigades in the theater involved in equipment distribution and reset. A pilot program is allowing units to turn in equipment for reset before returning home. This reduces the turn-around time on equipment repair and redistribution and protects

ADDENDUM

The Soldiers on the cover of the November–December 2008 issue are from the 39th Transportation Battalion, Deployment Processing Center, 21st Theater Sustainment Command.

the short time Soldiers have at home before they have to prepare for additional deployments. Lieutenant General Dunwoody said that Army depot realignments have also bolstered repair capacity within the AMC, improving capabilities threefold.

Lieutenant General Stephen M. Speakes, Deputy Chief of Staff, G–8, Department of the Army, said that more changes are needed to keep up with the high operating tempo of today's environment. New equipment production has not caught up with growth in the Army. Deployed unit equipment levels exceed modification table of organization and equipment requirements for certain items, and funding for resets continues to come in the form of supplemental funds.

RECENTLY PUBLISHED DOCTRINE

Joint Publication (JP) 4–0, Joint Logistics, is the keystone document for Department of Defense (DOD) joint logistics doctrine. Its contents apply to the Joint Staff, combatant commanders, subunified commands, joint task forces, subordinate components of these commands, the armed services, and combat support agencies. Changes to the document describe the concept of the joint logistics environment and joint logistics imperatives, the U.S. Transportation Command as the distribution process owner, the U.S. Joint Forces Command as the joint deployment process owner, the DOD supply chain, and multinational and interagency arrangements. The manual also describes the characteristics of joint logisticians, outlines core logistics and subordinate functional capabilities, and introduces joint logistics planning considerations.

Two appendices have been added to the publication: one covers joint logistics roles and responsibilities, and the other covers supply commodity executive agents. JP 4–0 includes discussion on joint logistics planning and execution, organization and control options, revised guidance on authorities and responsibilities, and a revised appendix on joint logistics boards, offices, centers, cells and groups. This revision discontinues the use of the functions of logistics, the elements of the logistics process, and

critical logistics enablers and deletes chapters on joint theater logistics and conflicts in the theater.

Field Manual (FM) 4–20.07, Quartermaster Force Provider Company, serves as an operational guide for leaders in Force Provider companies on critical wartime tasks and gives those working closely with a Force Provider company an understanding of the unit's mission essential task list. The FM covers the structure, operations, and environmental responsibilities of Force Provider companies. FM 4–20.07 is only available in electronic form.

FM 6–01.1, Knowledge Management Section, is the first step in incorporating knowledge management (KM) into Army doctrine. FM 6–01.1 provides the procedures needed to "effectively integrate KM into the operations of brigades, divisions, and corps," discusses KM's role in the operational Army and Army Force Generation, and presents emerging Army KM requirements. FM 6–01.1 also states that corps operations, command and control, and planning doctrine will soon incorporate KM. Feedback from the use of FM 6–01.1 and KM in ongoing operations will be incorporated into planning and command and control doctrine that will guide the development of an overarching KM field manual in the future.

Lieutenant General Mitchell H. Stevenson, Deputy Chief of Staff, G-4, Department of the Army, agreed. “We have enjoyed supplemental funding throughout this war, and we know that we are going to continue to need to get supplemental funding, but at some time that supplemental funding is going to be less than it is today.” Lieutenant General Stevenson said those in the logistics community will have to understand how to configure budget requests in a way that Congress will accept. “That is very much on our minds and the subject of how we build the POM [Program Objective Memorandum].”

Lieutenant General Speakes said funding would need to continue “for as long as Soldiers are deployed plus 2 to 3 years.” Other important goals include fully equipping units that will aid in homeland security and hazardous response missions stateside, finishing the “Grow the Army” initiative, and funding future force initiatives to turn them into current force realities.



The K-Max optionally piloted aircraft was used at a demonstration at Fort Eustis, Virginia, to show how the Army could potentially use aircraft for resupply missions without a pilot onboard. (Photo courtesy of Lockheed Martin Systems Integration-Owego)

Brigadier General Rodney Anderson, Director of Force Management under the Deputy Chief of Staff, G-3/5/7, Department of the Army, who was previously deployed to Afghanistan with the 82d Airborne Division, addressed challenges of ARFORGEN that he observed first hand. “First, we must continue to mature the network and the strategy of supporting units forward by essentially a network of logisticians linked to the industrial base. We’ve got to continue expanding the lessons and integrating other aspects of ARFORGEN . . . We’ve got to bring manning into the ARFORGEN cycle and mature the manning to the same level that the equipping is today.” Brigadier General Anderson said that we must also build sustainment capacity in coalition and national forces that we support. Lastly, he noted that streamlining and automating property accountability, especially at the company, battery, and troop levels, is “something that would go a long way in maintaining good visibility and be of great assistance to local leaders.”

Lieutenant General Stevenson observed that ARFORGEN readiness has improved with changes in accountability, saying that strategic partnerships with the Defense Logistics Agency and the U.S. Transportation Command have shortened the time it takes to reset equipment. He said properly positioning stocks will also continue to reduce transportation costs.

UNMANNED AERIAL SYSTEM TESTED FOR LOGISTICS RESUPPLY MISSIONS

The Aviation Applied Technology Directorate of the Army Research, Development, and Engineering Command at Fort Eustis, Virginia, teamed up with Lockheed Martin Systems Integration-Owego and Kaman Aerospace Corporation in April 2008 to test the ability of the K-Max optionally piloted aircraft to work as an unmanned aerial system (UAS) carrying supplies to units. If UASs performed resupply missions, CH-47 Chinook and UH-60 Black Hawk helicopter pilots could focus on the important mission of troop movement. The K-Max provides the option to use an onboard pilot if one is available, but it can also be controlled by a ground operator.

The commercially available aircraft features intermeshing rotors (a set of two rotors turning in opposite directions, mounted so they overlap without colliding) that eliminate the need for a tail rotor. The aircraft is capable of carrying a 6,000-pound external load at sea level and can carry up to four separate loads of 1,500 pounds for release at separate locations.

K-Max uses global positioning systems to find resupply delivery locations. The ground operator can either preprogram the locations or insert the location in real time while the aircraft is in flight. The Lockheed Martin technology used for mission management translates the ground controller's objectives into mission-executable plans, provides for unmanned flight, and understands and reacts to the dynamic battlefield environment and updated threat locations.

The technology demonstration at Fort Eustis was based on a number of previous science and technology programs. During the demonstration, researchers used the K-Max to take off without onboard safety pilot involvement, depart to a remote load pickup area and coordinate load pickup and delivery where the remote operator was able to position the aircraft over two loads using a downward facing camera and
(News continued on page 58)

PROFESSIONAL DEVELOPMENT

NEW PROPERTY ACCOUNTABILITY TEAM ADDRESS CRITICAL ISSUES

The Army Deputy Chief of Staff, G-1, has approved a proposal from the Army Combined Arms Support Command to create a skill identifier for personnel who have attended the Theater Logistics Studies Program (TLog) and to code positions in the force structure for those graduates. Logistics officers who receive the new skill identifier, P1, will be slotted into logistics positions in operational logistics units, such as theater sustainment commands, expeditionary sustainment commands, and sustainment brigades, or on joint and multinational staffs.

Establishment of the skill identifier will allow effective tracking of graduates and position requirements, ensuring career-long use of the graduates' knowledge, skills, and abilities.

The Army Logistics Management College at Fort Lee, Virginia, offers TLog to logistics officers in the ranks of O-3 and above who have at least 7 years of service and civilians in the grades of GS-13 and above with at least 5 years of logistics experience. Warrant officers can attend TLog by exception. For more information, view the ALMC course catalog online at www.almc.army.mil/ALMC_CATALOG.PDF.

COLLECTIVE TASKS FOR SUPPORT UNITS NEEDED FOR MAJOR COMBAT OPERATIONS

The Army Combined Arms Support Command is asking current and former commanders, staffs, and leaders of brigade support battalions (BSBs) and forward support companies (FSCs) to help identify the collective tasks that should be emphasized under major combat operations conditions. The command is especially interested in BSB and

FSC tasks for units supporting heavy, infantry, and Stryker brigades. The tasks will be used next summer to set the conditions for a new scenario that supports major combat operations training at the maneuver combat training centers.

Other individuals with experience or interest in these collective tasks are encouraged to submit input as well. To view what has been documented and to submit questions, comments, and recommendations, readers may visit the "BSB/FSC Unit Tasks for Major Combat Operations" discussion area located online at <https://forums.bcks.army.mil.aspx?id=662351>.

ARMY WAR COLLEGE SPONSORS STRATEGIC LANDPOWER ESSAY CONTEST

The Army War College and the Army War College Foundation are holding their 2009 edition of the Strategic Landpower Essay Contest. The competition is designed to advance the professional knowledge of the strategic role of landpower in joint and multinational operations. This year's essay topic is "Perspectives on Stability Operations and Their Role in U.S. Landpower."

The Army War College Foundation will award \$3,000 to the author of the best essay, \$1,500 to the second place writer, and \$500 to the third place winner. Anyone is eligible to enter and win the contest except those involved in the judging.

Essay entries must be original and not previously published and should not exceed 5,000 words. For more information or for a copy of the essay contest rules, writers should contact Dr. Michael R. Matheny at the college's Department of Military Strategy, Planning and Operations by telephone at (717) 245-3459 or DSN 242-3459 or by email at michael.matheny@us.army.mil. Submissions must be postmarked on or before 17 February 2009.

LOG NOTES

Safety Is Serious Business

Readiness is always of primary concern in all Army activities. It is the watchword for the conduct of the various operations required to maintain a mobile combat force. A unit measures its readiness by its capability to mobilize all its assets, people, and equipment. Deadlined vehicles, damaged equipment, and injured Soldiers are not combat ready.

A matter of growing concern is the direct drain that accidents in Army maintenance service and repair operations have on combat readiness. These operations are critical from a safety standpoint because of the high potential for accidents and injuries inherent in the type of work performed and the tools required. This accident risk demands an equal amount of safety measures.

I witness *many* safety violations in the magazines I receive through today's military distributions. For example, the March–April 2008 issue of *Army Logistician* shows several photos of mechanics, including the cover photo of a mechanic with a high-mobility multipurpose wheeled vehicle, working without personal protective equipment (PPE). This is incorrect. We need to work together to make safety the top priority while repairing equipment.

The first-line supervisor plays an important role in preventing personnel injuries and accidents. This individual should—

- Check work areas daily for unsafe conditions and unsafe acts. Make on-the-spot corrections when safety violations are found.
- Demand absolute compliance with safety rules and established work procedures.
- Make sure personnel are trained for the job and what is expected of them.
- Brief personnel on hazardous conditions to ensure they know the hazards. He should not assume that they will always act in the appropriate manner.

(News from page 57)

cues from personnel on site. From that point, the controller rerouted the mission to accommodate drop location updates and new threat indications, handed off control to a second operator in a remote location, dropped two 1,500-pound sling loads, and landed the aircraft without onboard pilot involvement.

Everyone is required to wear goggles during grinding and drilling operations and when using chemicals, working with systems under pressure, and working under vehicles. Hearing protection is needed during operations that produce damaging noise. Appropriate gloves are needed when working with chemicals, wire rope, or other operations that have the potential to injure the hands. A welding apron, gloves, face protection and barriers are necessary for welding operations.

Not all of this important safety equipment is used. We do not go to battle without our M-4 carbines, so we should not work on equipment without personal protective equipment. Using worn hand tools and shop tools and conducting forklift load tests, jack stand checks, and hydraulics function tests and checks all present potential hazards that cause accidents.

Use a maintenance safety checklist to ensure the mechanics are complying with regulations, safety-of-use messages, and all safety standing operating procedures.

I am a field maintenance shop supervisor for the Pennsylvania Army National Guard and have been in this field for 34 years. Soldiers and civilians need to get with the safety program. We do not need the loss of any Soldiers to an accident.

Thanks you for all you do in the field, but remember— Safety First.

**CW4 GEAMS R. BLEVINS
PAARNG**

Log Notes provides a forum for sharing your comments, thoughts, and ideas with other readers of *Army Logistician*. If you would like to comment on an *Army Logistician* article, take issue with something we've published, or share an idea on how to do things better, consider writing a letter for publication in *Log Notes*. Your letter will be edited only to meet style and space constraints. All letters must be signed and include a return address. However, you may request that your name not be published. Mail a letter to EDITOR ARMY LOGISTICIAN, ALMC, 2401 QUARTERS ROAD, FT LEE VA 23801-1705; send a FAX to (804) 765-4463 or DSN 539-4463; or send an e-mail to leeealog@conus.army.mil.

An Army Aviation and Missile Research, Development, and Engineering Center project with Kaman Aerospace for this year will concentrate on expanding the loaded flight weight limits, speed, and availability. Lockheed Martin is planning to convert the optionally piloted K-Max to a fully autonomous aircraft and is exploring the use of multiple unmanned K-Max to conduct a resupply mission.

Writing for *Army Logistician*

If you are interested in submitting an article to *Army Logistician*, here are a few suggestions that may be helpful. Before you begin writing, review a past issue of *Army Logistician*; it will be your best guide. Keep your writing simple and straightforward (try reading it back to yourself or to a colleague). Attribute all quotes. Identify all acronyms and technical terms. *Army Logistician's* readership is broad; do not assume that those reading your article are necessarily Soldiers or that they have background knowledge of your subject.

Do not worry too much about length; just tell your story, and we will work with you if length is a problem. However, if your article is more than 4,000 words, you can expect some cutting.

The word limit does not apply to *Spectrum* articles. *Spectrum* is a department of *Army Logistician* intended to present researched, referenced articles typical of a scholarly journal. *Spectrum* articles can be longer than standard feature articles and are published with footnotes.

Instructions for Submitting an Article

Do not submit your article in a layout format. A simple Word document is best. Do not embed photos, charts, or other graphics in your text. Any graphics you think will work well in illustrating your article should be submitted as separate files. Make sure that all graphics can be opened for editing by the *Army Logistician* staff.

Photos are a great asset for most articles, so we strongly encourage them. Photos may be in color or black and white. Photos submitted electronically must have a resolution of at least 300 dpi (.jpg or .tif). Make sure to include a description of what each photo depicts. Please try to minimize use of PowerPoint charts; they usually do not reproduce well, and we seldom have the space to make them as large as they should be.

Army Logistician publishes only original articles, so please do not send your article to other publications. Ask your public affairs office for official clearance for open publication before submission to *Army Logistician*. **A clearance statement from the public affairs office should accompany your submission.** Exceptions to the requirement for public affairs clearance include historical articles and those that reflect a personal opinion or contain a personal suggestion. If you have questions about this requirement, please contact us at leealog@conus.army.mil or (804) 765-4761 or DSN 539-4761.

Submit your article by email to leealog@conus.army.mil or by mail to EDITOR ARMY LOGISTICIAN/ALMC/2401 QUARTERS RD/FT LEE VA 23801-1705. If you send your article by mail, please include a copy on floppy disk if possible. We look forward to hearing from you.

Army Logistician (ISSN 0004-2528) is a bimonthly professional bulletin published by the Army Logistics Management College, 2401 Quarters Road, Fort Lee, Virginia 23801-1705. Periodicals postage is paid at Petersburg, VA 23804-9998, and at additional mailing offices.

Mission: *Army Logistician* is the Department of the Army's official professional bulletin on logistics. Its mission is to publish timely, authoritative information on Army and Defense logistics plans, programs, policies, operations, procedures, and doctrine for the benefit of all logistics personnel. Its purpose is to provide a forum for the exchange of information and expression of original, creative, innovative thought on logistics functions.

Disclaimer: Articles express opinions of authors, not the Department of Defense or any of its agencies, and do not change or supersede official Army publications. The masculine pronoun may refer to either gender.

Reprints: Articles may be reprinted with credit to *Army Logistician* and the author(s), except when copyright is indicated.

Distribution: Units may obtain copies through the initial distribution system (DA Form 12 series). Private domestic subscriptions are available at \$23.00 per year by writing to the Superintendent of Documents, P.O. Box 371954, Pittsburgh, PA 15250-7954, or by visiting <http://bookstore.gpo.gov> on the Web. For credit card orders, call (866) 512-1800. Subscribers should submit address changes directly to *Army Logistician* (see address below). *Army Logistician* also is available on the World Wide Web at <http://www.almc.army.mil/alog>.

Postmaster: Send address changes to: EDITOR ARMY LOGISTICIAN/ALMC/2401 QUARTERS RD/FT LEE VA 23801-1705.

Index of *Army Logistician* Articles—2008

January–February		
Adapted Missions for Petroleum Liaison Detachments	COL Mark Asbury	20
An Interview With the Army's Senior Enlisted Logistician	CSM Daniel K. Elder and Diana Dawa	2
Combat Escort Team Validation	SSG Joshua Salmons	24
Female Medics in Line Units	CPT Lisa M. Dennis	18
Five Key Areas of the 4th Sustainment Brigade's Success	SSG Joshua Salmons	8
Joint Asset Visibility: Why So Hard? The Way Ahead	LTC James C. Bates, USA (Ret.)	30
Lessons Learned From a Reception, Staging, Onward Movement, and Integration Site	MAJ Bryan K. Ouellette, MEARNG	28
Maintenance in the Brigade Special Troops Battalion	MAJ James W. Craft and CW3 Louis Watkins	4
Operation Mountain Thrust	CPT Carolyn Trias-DeRyder	12
R–CAATs: Bridging the Information Gap	MG Mitchell H. Stevenson	1
<i>Spectrum</i> : A Values-Based Critique of Lean and Six Sigma as a Management Ideology	Dr. Christopher R. Paparone	34
Supplying Forward Operating Bases	CPT Kristie Richardson	16
The Need for Cross-Training at the Company Level	CPT Charles L. Arnold	17
March–April		
Building an Army for Afghanistan	MAJ Jason A. Crowe	4
Defeating the Threat to Sustainment Operations	COL Bradford K. Nelson	33
Ensuring CLP Success	CPT Amy E. Cronin and 1LT Gregory Sterley	30
Logistics Force Generation for Iraq	LTC David Beougher and SFC Bruce A. Haynes, USA (Ret.)	14
Low-Cost, Low-Altitude Aerial Resupply	Nicholas C. Zello and COL Daniel L. Labin, USA (Ret.)	20
Preparing for the Big Chill	Staff Feature	17
Ready, Set, Redeploy	MAJ Brandon Grubbs, MAJ Bill Haas, and LTC Robert Reynolds	10
SAAS-MOD Training Challenges	CPT Martin Caban	24
<i>Spectrum</i> : The Iron Mountains of Post-Cold War Interventions	COL Kenneth E. King	38
Supporting the Army's First Battlefield Surveillance Brigade	1LT Orna T. Bradley	26
Sustainment is Our Middle Name	Charles W. Fick, Jr.	8
The Army's New Logistics Branch: An Interview With CASCOM's Commanding General	MG Mitchell H. Stevenson	1
The Battlefield Contracting Community of Practice	Patrick Conway	46
May–June		
Automating Property Accountability	COL Kenneth A. Scott, USAR, and MAJ Charles W. Weko, USAR	29
BCT Logistics in Al Anbar Province	MAJ Mark D. Pike, PAARNG	22
Bomb Squads and EOD Personnel: Interoperability for Homeland Defense	COL Dick A. Larry	6
Collecting Information From the Field	Earl C. Driver	10
<i>Commentary</i> : Is It Time to Reconsider Training for PBUSE?	CW4 Joel Lockhart	32
Graduate-Level Education for Logisticians	CPT Stacy Pennington	34
Helpful Thoughts for Junior Leaders	LTC Kenneth Long, USA (Ret.)	15
<i>Spectrum</i> : From Just In Case to Just In Time	MAJ Eric T. Wallis	36
Sustainment Center of Excellence Lifelong Learning Portal: Gateway to Lifelong Learning for Logisticians	MG Mitchell H. Stevenson	1
Understanding the Supply Chain Operations Reference Model	MAJ Michael B. Siegl	18
Unit Deactivation Logistics in Review	MAJ Vincent C. Nwafor	2
Warrior Logisticians: Establishing an SSA From the Ground Up	1LT Brice R. Westhoven	12
Weakening the Enemy From Within	Noel D. Matchett	39

July–August

A Fond Farewell	LTG Mitchell H. Stevenson	1
Carrier Association Reporting System	Fran Willis and Cheryl L. Freeman	7
Chinese Logistics Modernization	CPT David A. Payne	10
<i>Commentary: A Predictive Diagnostic Maintenance System</i>	SSG Michael Winkler	45
<i>Commentary: Fostering Iraqi Army Logistics Success</i>	LTC Thomas M. Magee, USAR	16
Enhanced Logistics Tracking and Monitoring Through Sensor Technology	Janina W. Plinsky and Jerry Rodgers	13
Executive Education for Depot and Arsenal Leaders	Jerry Shinn	39
Field-Portable Propellant Stability Test Equipment	Elena M. Graves	20
MDMP at the SDDC: The Art and Science of Terminal Operations	LTC Marshall N. Ramsey and MAJ Ryon F. Adams	3
New Gear for Afghan Commandos	PO1 David Votroubek, USNR	12
On the Road to Condition-Based Maintenance for Army Vehicles	Mark S. Bounds, Mary Calomeris, Michael Pohland, and Marguerite Shepler	42
Stryker Brigade Combat Teams Need Forward Support Companies	LTC Danny F. Tilzey, MAJ Gary Kasavicha, and MAJ Charles X. Rote	26
Successful Implementation of Logistics Support Teams in an SBCT	LTC Dwayne M. Butler, MAJ Kenneth C. Bradford, and CPT Juliane C. Schwetz	33
The Chief of Staff's Imperatives and the Army Field Support Brigade	LTC Jordan S. Chroman	40
Wartime Host Nation Support on the Korean Peninsula	LTC Kam S. Gunther	8

September–October

A Letter From Major General James E. Chambers	MG James E. Chambers	1
An Integrated Enterprise Approach to AIT	David L. Dias and Timothy P. Ringdahl	2
BCS3: Getting the Most Out of a Strategic Sustainment Tool	LTC S. Eric Stewart	4
BSB Support to Advisory Teams in Iraq	MAJ Andrew Hotaling and MAJ Jason McGuire	29
Combined Logistics Excellence Awards: What It Takes to Win	Staff Feature	37
Exchange Pricing Improves Repairable Item Management	Staff Feature	44
Field Support Company Maintenance Operations During Deployment	CW5 Joseph W. Floriano, MIARNG	27
Fifty-Two Things You Might Want to Know About In-Transit Visibility	Alexander F. Barnes and Richard K. Boch	10
Flexible Support for the Heavy BCT	CPT John F. Jacques, 1LT Justin T. Bergen, 1LT Sonya S. Standefer, and 1LT Carl S. Miller	33
Iraqi Truck Company Transformation	Staff Feature	24
Logistics Transformation in Europe: Maintaining Support While Performing Expeditionary Missions	COL Martin B. Pitts and MAJ Kenneth M. Leeds, Jr.	15
MDMP: One Tool in the Commander's Tool Chest	MAJ John D. Nawoichyk	18
Sense and Respond: Military Logistics in a Global Security Environment	MAJ Michael F. Hammond	6
<i>Spectrum: The Distribution Dilemma: That Last Tactical Mile</i>	MAJ Kevin F. Daniels, USAR	39
The Army Logistics University	Barbara G. Mroczkowski	20

November–December

DCAM: Managing MEDLOG Systems on the Battlefield	Bill Snethen	20
<i>Ee Afghanistan Ast: Medical Logistics Mentoring in the Afghan National Army</i>	MAJ Scott C. Woodard	26
Integrating Contractors Into Brigade Support Battalion Operations	MAJ Damien Green	2
Logistics Status Reports and the Logistics Common Operating Picture	CW4 Timothy N. McCarter, Sr.	5
Measures to Prevent Profiles in Combat Support Commands	LT Sara D. Thomas, USN	22
Project Management Principles for Unit Logisticians	LTC Paul Wakefield	17
Providing S–2 Support for a Brigade Support Battalion	CPT Mary K. Kahler	8
Sense and Respond: Logistics on the Insurgent Battlefield	MAJ Michael F. Hammond	33
SETAF Mechanics Train Botswanan Soldiers	Staff Feature	36
<i>Spectrum: Delivering Value Through Logistics</i>	MAJ Jennifer M. Stephens	43
Supply Line Warfare	Dr. Cliff Welborn	12
The Army Reserve at 100: An Emerging Operational Force	Staff Feature	15
The Nature of Knowledge in the Profession of Military Logistics	Dr. Christopher R. Paparone	39
The Sustain Warfighters' Forum: Sharing What You Know	MG James E. Chambers	1

ISSN 0004-2528
DEPARTMENT OF THE ARMY
ARMY LOGISTICIAN
US ARMY LOGISTICS MANAGEMENT COLLEGE
2401 QUARTERS ROAD
FORT LEE VIRGINIA 23801-1705

PERIODICALS POSTAGE
AND FEES PAID
AT PETERSBURG VIRGINIA
AND ADDITIONAL CITIES

Official Business

Coming in Future Issues—

- Theater Support From the 401st AFSB Perspective
- The Logistics Transition Team
- Protecting Our Logistics Assets
- Pit Crew Maintenance in the Brigade Support Battalion
- RSR and CSR: Why the Confusion?
- CORs and Contingency Contracting
- Army Acquisition and Web-based PBUSE
- The Question of Command: Modularity and Logistics
- Preparing for the Stryker Brigade Blue-to-Green Transition
- Brigade Logistics Support Team
- U.S. Army Logistics in World War I