

MSHA Approval Number: 120M-09.1
120 PSI PMR Reinforced Concrete Seal 12ft X 40ft
Precision Mine Repair
For Information Contact Jeff Kearns or Jim Hise at 618.272.7220

Seal Installation Guidelines for the PMR Reinforced Concrete Main Line Seal

Prepared by:

Precision Mine Repair
Ridgeway, Illinois

Hurst-Rosche Engineers, Inc.
Springfield, Illinois

Date:

September 9, 2009

MSHA Approval Number: 120M-09.1
120 PSI PMR Reinforced Concrete Seal 12ft X 40ft
Precision Mine Repair
For Information Contact Jeff Kearns or Jim Hise at 618.272.7220

Seal Installation Guidelines for the PMR Reinforced Concrete Main Line Seal

Table of Contents

<u>SECTION</u>	<u>PAGE</u>
Phase 1 – Pull-Test	1
Phase 2 – Seal Area Preparation	1-2
Phase 3 – Material List	2
Phase 4 – Gas-Sampling Pipe, Water Drainage System & Water Height Measuring System	3-4
Phase 5 – Seal Installation Instructions	4-8

DETAIL

- 120-psi 12ft x 40ft Blast Seal for MSHA Final Ruling Detail
- 120-psi 12ft x 40ft Blast Seal Plan Sheet 1 of 2
- 120-psi 12ft x 40ft Blast Seal Plan Sheet 2 of 2

MSHA Approval Number: 120M-09.1
120 PSI PMR Reinforced Concrete Seal 12ft X 40ft
Precision Mine Repair
For Information Contact Jeff Kearns or Jim Hise at 618.272.7220

Seal Installation Guidelines for the PMR Reinforced Concrete Main Line Seal

Phase 1
Pull Test

- 1.1 Set-up pull-test equipment in an area with the same type of strata as the particular ventilation seal area.
- 1.2 At the testing location, scale the roof area to competent strata and dispose of scaled material.
- 1.3 At the testing location, scoop or shovel the floor area to competent strata and dispose of scooped or shoveled material.
- 1.4 Drill two 1 3/8" diameter holes (min. 2'-0" depth), one each in the roof and floor.
- 1.5 Insert enough resin into the floor hole to ensure the hole is fully grouted.
- 1.6 While rotating the bar, push the test bar into the hole.
- 1.7 When the test bar reaches the drilled depth, rotate the bar in accordance to the resin manufacturer's recommendations.
- 1.8 Stop rotation and hold the test bar in place in accordance to the resin manufacturer's recommendations.
- 1.9 Repeat Steps 1.4-1.8 for the roof test bar.
- 1.10 Let the resin set in accordance to the resin manufacturer's recommendations.
- 1.11 Slide the ram jack onto floor test bar.
- 1.12 Pump the ram at one-ton increments until either 30 tons is reached or the stratum fails. If stratum fails, repeat Steps 1.4-1.12 with a deeper drilled hole. Once 30 tons is reached, the stratum has passed and testing ceases.
- 1.13 Repeat Steps 1.10-1.12 for the roof test bar.

Phase 2
Seal Area Preparation

- 2.1 Measure the proposed ventilation seal location to insure that the new ventilation seal will be installed no less than 10'-0" from the corner of any pillar.
- 2.2 If an existing ventilation seal prevents the no less than 10'-0" requirement, a new ventilation seal can be installed no less than 5'-0" from the corner of any pillar if the following criteria is met:
 - Both ribs are to be reinforced by shotcreting bolted wire mesh, a distance outby of the existing ventilation seal no less than the proposed ventilation seal thickness.
 - New ventilation seal must be constructed directly in front of the existing ventilation seal.
 - The outby face of the new ventilation seal can be no less than 5'-0" from the corner of any pillar.
- 2.3 At the proposed ventilation seal location, collect and pump any standing water or divert any flowing water around the ventilation seal location. The ventilation seal installation location is allowed to be damp.
- 2.4 At the proposed ventilation seal location, scale the roof area to competent strata for a distance of 3 feet on each side of the ventilation seal and dispose of scaled material.

MSHA Approval Number: 120M-09.1
120 PSI PMR Reinforced Concrete Seal 12ft X 40ft
Precision Mine Repair
For Information Contact Jeff Kearns or Jim Hise at 618.272.7220

Seal Installation Guidelines for the PMR Reinforced Concrete Main Line Seal

- 2.5 At the proposed ventilation seal location, scale the rib area to competent strata for a distance of 3 feet on each side of the ventilation seal and dispose of all scaled material.
- 2.6 At the proposed ventilation seal location, scoop or shovel the floor area to competent strata for a distance of 3 feet on each side of the ventilation seal and dispose of scooped or shoveled material.
- 2.7 Re-measure the width and height of the proposed ventilation seal location after scaling back of the roof, floor and ribs, to insure the proposed ventilation seal hasn't exceeded the maximum height & width design limits.
- 2.8 Remove all loose debris and foreign objects in direct line to the proposed ventilation seal location for 50'-0" both inby and outby from the proposed ventilation seal location.

Phase 3
Material List

- 3.1 29 gauge vented or non-vented sheet metal backing.
- 3.2 3D-"wire mesh" Panel with the polystyrene removed.
- 3.3 Tie wire, 16-gage minimum annealed type and concrete stands.
- 3.4 Stanley/ HR – CLP – 2 /panel clips
- 3.5 Minova Lockset E-Series resin, DuPont Fasloc H-Series resin, Minova Anchortite Resin or equivalent resins that have met the pull test requirements.
- 3.6 Stirrups(s bars): #4 deformed reinforcing bar stirrups, ASTM A 615, Grade 60
- 3.7 Horizontal Bars (h bars): #6 deformed reinforcing bar, ASTM A 615, Grade 60
- 3.8 Vertical Bars (v bars): #9 deformed reinforcing bar, ASTM A 615, Grade 60
- 3.9 Vertical Bars (v1 bars): #7 deformed reinforcing bar, ASTM A 615, Grade 60
- 3.10 Dowels (d bars): #9 deformed reinforcing bar, ASTM A 615, Grade 60
- 3.11 Shotcrete: (by Weight) 25% cement / 75% sand (See specifications).

Note: All construction materials are to be stored in such a manner as to avoid contamination and deterioration. All cementitious materials are to be dated and stored in weather-protected areas or containers. All cementitious material that has hardened or been stored beyond its dated six-month expiration is to be discarded. No aggregates are to be stored directly on the ground unless a sacrificial layer is left undisturbed. No reinforcing bars or accessories are to be stored directly on the ground. All reinforcing bars that have loose scaling rust are to be discarded. Surface rust is acceptable. An appropriate barrier may be placed on the ground and the materials stored on top of the barrier.

MSHA Approval Number: 120M-09.1
120 PSI PMR Reinforced Concrete Seal 12ft X 40ft
Precision Mine Repair
For Information Contact Jeff Kearns or Jim Hise at 618.272.7220

Seal Installation Guidelines for the PMR Reinforced Concrete Main Line Seal

Phase 4
**Gas-Sampling Pipe, Water Drainage System &
Water Height Measuring System**

- 4.1 One gas-sampling pipe is to be installed according to the MSHA approved mine ventilation seal plan with the following requirements.
- For new ventilation seals, the gas-sampling pipe is to extend inby to approximately the center of the 1st connecting crosscut or half the distance of the entry if there is no crosscut.
 - For new ventilation seals being constructed directly in front of existing ventilation seal and share the same pillars, it is required for the gas-sampling pipe to be connected to the existing ventilation seal gas-sampling piping.
 - The gas-sampling pipe is to be no greater than 1-inch inside diameter with no less than 240-psi rating.
 - The gas-sampling pipe is to be installed no more than 12-inches from the roof and with no less than 18-inches clearance from either rib line.
 - The gas-sampling pipe is to be supported by hangers or on cribbing.
 - No conductive material piping is allowed to be installed through the ventilation seal. Conductive material piping is allowed if installed no closer than 4” from either face of the ventilation seal.
 - The gas-sampling pipe is to be equipped outby side with a generic ball shut-off valve with no less than 240-psi rating, fitted to facilitate taking gas samples and at a height accessible to take gas samples.
 - For new ventilation seals being constructed in front of existing ventilation seal and share the same pillars, but leave a void space in-between seals, a additional gas-sampling pipe will be required to enabling sampling of the void area in-between seals.
- 4.2 The Water Drainage System is to be installed according to the MSHA approved mine ventilation seal plan with the following requirements.
- Install a water drainage system consisting of no more than three pipes in any given ventilation seal.
 - For new ventilation seals being constructed directly in front of an existing ventilation seal, it will be required for the water drainage system pipe to be connected to the existing ventilation seal water drainage system.
 - Install a 4-inch, 6-inch or 8-inch diameter corrosion resistant piping having strength properties of no less than 240-psi pressure rating at each drainage system location.
 - Install each drainage system pipe through the ventilation seal at a height, which provides no more than 18-inches clearance measured from the bottom of pipe to the ventilation seal bottom edge and with no less than 18-inches clearance from either rib line.
 - No conductive material piping is allowed to be installed through the ventilation seal. Conductive material piping is allowed if installed no closer than 4” from either face of the ventilation seal.

MSHA Approval Number: 120M-09.1
120 PSI PMR Reinforced Concrete Seal 12ft X 40ft
Precision Mine Repair
For Information Contact Jeff Kearns or Jim Hise at 618.272.7220

Seal Installation Guidelines for the PMR Reinforced Concrete Main Line Seal

- For multiple pipe drainage systems, the horizontal distance between the pipes is to be no less than 3 feet.
 - No vertical or horizontal rebars are to be cut, moved, or removed to install a pipe.
 - 3D “wire mesh” Panels are to be modified to allow placement of all pipes.
 - A water trap and valve of the same diameter as the water drainage piping and no less 240-psi pressure rating is to be installed on the outby side of each drainage pipe.
 - Each valve is to be installed on the inby side of the water trap. Each water trap is to be U-shaped and initially filled with and maintained full of a non-evaporative liquid, unless mine water is draining through the pipe.
 - To minimize the available depth of water to impound against the ventilation seal, the U-portion of the water trap can be recessed into the mine floor.
 - A low weir(s) or catchment, no more than 12-inches high, is to be constructed across the entry inby of the ventilation seal to trap sediment and debris that may clog the water drainage system piping.
- 4.3 If included on the MSHA approved mine ventilation seal plan, the water height measuring system is to be installed according to the MSHA approved mine ventilation seal plan with the following requirements.
- Install two horizontal up to 1-inch inside diameter non-metallic pipes having strength properties of no less 240-psi pressure rating through the seal.
 - Install the bottom pipe securely through the seal at the approximate height of the top of the water trap and install the top pipe securely through the seal close to the roof.
 - Install shut-off valves having strength properties of no less 240-psi pressure rating on the outby side of each pipe.
 - Install 90 deg. elbows on the outby side of each pipe after the valves are in place.
 - Install a clear plastic tube between these elbows for viewing the water elevation inby of the seal.

Phase 5
Seal Installation Instructions

- 5.1 Re-examine the ventilation seal location area to insure that the roof, ribs and the floor are free from debris, foreign objects and extraneous materials.
- 5.2 Measure and mark the dowel spacing in the roof and floor according to the attached detail. The inby and outby dowels are to be installed no more than 7” from each rib line and no greater than 14” centers across the width of the entry.
- 5.3 All cementitious material that has hardened or been stored beyond its dated six-month expiration is to be discarded. All reinforcing bars that have loose scaling rust are to be discarded. Surface rust is acceptable.
- 5.4 Install the inby dowels.
- Drill 1 3/8” diameter holes for the inby dowels no less than 6-inch deeper than the depth required from the in-mine pull tests to yield the dowel or 2’-0”, whichever is greater.

MSHA Approval Number: 120M-09.1
120 PSI PMR Reinforced Concrete Seal 12ft X 40ft
Precision Mine Repair
For Information Contact Jeff Kearns or Jim Hise at 618.272.7220

Seal Installation Guidelines for the PMR Reinforced Concrete Main Line Seal

- Chemically grout each inby dowel with a return equal or greater than the pull test or 1'-6", whichever is greater.
 - Place a stirrup on the floor and the roof to insure that the hole-spacing from the inby dowel and the outby dowels are marked correctly. Note: Installation of the stirrups will be easier if the inby and out by dowels are close as possible in alignment with one another.
- 5.5 Install the center dowels to stagger the inby and outby dowels.
- Drill 1 3/8" diameter holes for the center dowels no less than 6-inch deeper than the depth required from the in-mine pull tests to yield the dowel or 2'-0", whichever is greater.
 - Chemically grout each outby dowel with a return equal or greater than the pull test or 1'-6", whichever is greater.
- 5.6 Install the outby dowels.
- Drill 1 3/8" diameter holes for the outby dowels no less than 6-inch deeper than the depth required from the in-mine pull tests to yield the dowel or 2'-0", whichever is greater.
 - Chemically grout each outby dowel with a return equal or greater than the pull test or 1'-6", whichever is greater.
- 5.7 Install formwork of sufficient strength to withstanding the pressures resulting from placement of shotcrete with minimal deflection. Forms can be of plywood and wood board construction, concrete blocks or steel panels. **Note:** For new ventilation seals being constructed directly in front of an existing ventilation seal, the existing ventilation seal outby face can function as the backing for the new ventilation seal.
- Measure from the inby dowels no less than 2 1/2" and mark the roof and the floor.
 - Install either cribs or props inby from the marks at least 2 1/2" from the inby row of dowels, at equal spacing from rib to rib and close enough to assist the approved formwork to withstand the placement of shotcrete with minimal deflection first. **Note:** The first crib or prop from each rib is to be no more than three feet away.
 - Attach the approved formwork to the cribs or the props. **Note:** For new ventilation seals being constructed directly in front of an existing ventilation seal, the existing ventilation seal outby face will function as the backing for the new ventilation seal and no cribs or props inby are required.
 - Measure from the backing to insure that you have at least 2" of clearance between the dowels and the backing for the entire ventilation seal width and height.
 - Cut appropriate size holes in the formwork for the gas-sampling pipe and water drainage pipe(s) as described in Phase 4.
- 5.8 Thread the couplers onto each inby dowel rod until either it is threaded at least one half of the coupler length or until it bottoms out on the centering pin.
- 5.9 Thread the dowel extensions into each coupler on the inby dowel rods.
- 5.10 Install and tie with tie wire two inby horizontal rebar 2 1/2" to 6" from roof and floor on the outby side of the vertical inby dowel. **Note:** This allows a place to affix the vertical rebar.
- Install the 1st inby horizontal rebar 10" on center below the previously install inby horizontal rebar near the roof.
 - Install the 2nd inby horizontal rebar 10" on center above the previously installed inby horizontal rebar near the floor.

MSHA Approval Number: 120M-09.1
120 PSI PMR Reinforced Concrete Seal 12ft X 40ft
Precision Mine Repair
For Information Contact Jeff Kearns or Jim Hise at 618.272.7220

Seal Installation Guidelines for the PMR Reinforced Concrete Main Line Seal

- The inby horizontal rebars may be cut to fit or overlapped using a minimum bar lap of 1'-7".
- 5.11 Install and tie with tie wire the inby #9 vertical rebar.
- Install the 1st inby #9 vertical rebar 2½" to 4½" from either the right or left rib line and with 2½" to 6" clearance from both the roof and floor.
 - Continue installing the inby #9 vertical rebar at no more than 12" centers and with 2½" to 6" clearance from both the roof and floor across the entire width of the entry.
 - Install the last inby #9 vertical rebar 2½" to 4½" from the opposite rib line as the first inby vertical rebar and with 2½" to 6" clearance from both the roof and floor.
 - The inby #9 vertical rebars may be cut to fit or overlapped using a minimum bar lap of 3'-6".
- 5.12 Continue installing the remaining inby horizontal rebar at no more than 10" centers and with 2½" to 4½" clearance from each rib line along the entire height of the entry.
- The inby horizontal rebars may be cut to fit or overlapped using a minimum bar lap of 1'-7".
- 5.13 Install and tie with tie wire the inby #7 vertical rebar outby of the inby horizontal bars.
- Install the 1st inby #7 vertical rebar 2½" to 4½" from either the right or left rib line and with 2½" to 6" clearance from both the roof and floor.
 - Continue installing the inby #7 vertical rebar at no more than 12" centers and with 2½" to 6" clearance from both the roof and floor across the entire width of the entry.
 - Install the last inby #7 vertical rebar 2½" to 4½" from the opposite rib line as the first inby vertical rebar and with 2½" to 6" clearance from both the roof and floor.
 - The inby #7 vertical rebars may be cut to fit or overlapped using a minimum bar lap of 2'-1".
- 5.14 Install and tie with tie wire two outby horizontal rebar.
- Install the 1st outby horizontal rebar in direct line with the top most inby horizontal rebar, matching clearance and height.
 - Install the 2nd outby horizontal rebar in direct line with the bottom most inby horizontal rebar, matching clearance and height.
 - The inby horizontal rebars may be cut to fit or overlapped using a minimum bar lap of 1'-7".
- 5.15 Install and tie with tie wire the stirrups.
- Install the top stirrups according to the attached Blast Seal Drawings Sheets 1 & 2 by placing each stirrup to rest on top of the inby and outby top most horizontal rebar's insuring that there is 2½" of clearance over the top of the stirrups.
 - Install the bottom stirrups according to the attached Blast Seal Drawings Sheets 1 & 2 by placing each stirrup to rest on top of the inby and outby bottom most horizontal rebar' insuring that there is 2½" of clearance underneath the bottom of the stirrups.
- 5.16 Install the inby 3D "wire mesh" Panel.
- Install the inby 3D "wire mesh" Panel according to the attached Blast Seal Drawings Sheets 1 & 2 and with 2½" to 4½" clearance from each rib line. **Note:** Due to the stirrups, proper clearance will automatically be provided on the top and the bottom of the panels.
- 5.17 Thread the couplers onto each center dowel rod until either it is threaded at least one half of the coupler length or until it bottoms out on the centering pin.

MSHA Approval Number: 120M-09.1
120 PSI PMR Reinforced Concrete Seal 12ft X 40ft
Precision Mine Repair
For Information Contact Jeff Kearns or Jim Hise at 618.272.7220

Seal Installation Guidelines for the PMR Reinforced Concrete Main Line Seal

- 5.18 Thread the dowel extensions into each coupler on the center dowel rods.
- 5.19 Install the outby 3D “wire mesh” Panel.
- Install the outby 3D “wire mesh” Panel according to the attached Blast Seal Drawings Sheets 1 & 2 and with 2½” to 4½” clearance from each rib line. **Note:** Due to the stirrups, proper clearance will automatically be provided on the top and the bottom of the panels.
- 5.20 Install and tie with tie wire the outby #7 vertical rebar to the outby horizontal bars.
- Install the 1st outby #7 vertical rebar 2½” to 4½” from either the right or left rib line and with 2½” to 6” clearance from both the roof and floor.
 - Continue installing the outby #7 vertical rebar at no more than 12” centers and with 2½” to 6” clearance from both the roof and floor across the entire width of the entry.
 - Install the last outby #7 vertical rebar 2½” to 4½” from the opposite rib line as the first inby vertical rebar and with 2½” to 6” clearance from both the roof and floor.
 - The outby #7 vertical rebars may be cut to fit or overlapped using a minimum bar lap of 2’-1”.
- 5.21 Thread the couplers onto each outby dowel rod until either it is threaded at least one half of the coupler length or until it bottoms out on the centering pin.
- 5.22 Thread the dowel extensions into each coupler on the outby dowel rods.
- 5.23 Continue installing the remaining outby horizontal rebar at no more than 10” centers and with 2½” to 4½” clearance from each rib line along the entire height of the entry.
- The outby horizontal rebars may be cut to fit or overlapped using a minimum bar lap of 1’-7”.
- 5.24 Install and tie with tie wire the outby #9 vertical rebars.
- Install the 1st outby #9 vertical rebar 2½” to 4½” from the neither rib line and with 2½” to 6” clearance from both the roof and floor.
 - Continue installing the outby #9 vertical rebar at no more than 12” centers and with 2½” to 6” clearance from both the roof and floor across the entire width of the entry.
 - Install the last outby #9 vertical rebar 2½” to 4½” from the rib line and with 2½” to 6” clearance from both the roof and floor.
 - The outby #9 vertical rebars may be cut to fit or overlapped using a minimum bar lap of 3’-6”.
- 5.25 Re-examine the ventilation seal construction to verify that all reinforcement is placed in accordance to the design and specification tolerances.
- 5.26 Shotcrete shall be tested by the manufacture prior to shipment of the shotcrete to insure the quality of the product.
- 5.27 Construct a minimum of two shotcrete test panels for each ventilation seal.
- 5.28 Each test panel is to be constructed in accordance with *ASTM C1140 with no less than 14” Wide x 14” Length x 3 ½” Depth so to enable a **minimum of 2** (no less than 2” dia.) cores or 2 (no less than 2”) cube samples to be procured and tested from each test panel for compressive strength testing to the design strength minimum of 4500-psi. ***Note:** ASTM C1140 allows for variant core size samples with correction factors to be used.
- 5.29 Each test panel is to be field cured in the mine before being transported out of the mine for testing.

MSHA Approval Number: 120M-09.1
120 PSI PMR Reinforced Concrete Seal 12ft X 40ft
Precision Mine Repair
For Information Contact Jeff Kearns or Jim Hise at 618.272.7220

Seal Installation Guidelines for the PMR Reinforced Concrete Main Line Seal

- 5.30 Place the shotcrete into the forms using the dry-mix shotcrete process. Material is fed into the shotcrete hopper directly or with a pre-dampener. Compressed air conveys the material to the nozzle. Water is injected at the nozzle for placement.
- 5.31 All water used with shotcrete shall be fresh, clean, potable and free of deleterious amounts of oil, acid, salt or alkali, except that non-potable water may be used if it conforms to either
- ASTM C1602 - Standard Specifications for Mixing Water Used in the Production of Hydraulic Cement Concrete
 - Article 1002.02 of the Illinois Department of Transportation Standard Specifications for Road and Bridge Construction (Adopted Jan. 1, 2007), including all addenda.
- 5.32 All nozzlemen shall have had experience and/or training in the application of shotcrete on at least two projects of comparable nature and shall be certified in accordance with ACI 506.3R – Guide to Certification of shotcrete Nozzlemen.
- 5.33 Shotcrete the ventilation seal in place with no less than 2” clear cover provided for the outby dowels and vertical rebars to a minimum of 40” thick.
- 5.34 If placement of shotcrete is interrupted for more than 1-hr, the following steps will be completed before resuming the placement of shotcrete.
- Apply a rinse-coating of water as a bonding agent to the ventilation seal until the entire surface has a wet-shine appearance.
 - Wait for the water to drain off or absorb into the ventilation seal surface before resuming the placement of shotcrete.
- 5.35 If placement of shotcrete is interrupted for more than 4-hrs, the following steps will be completed before resuming the placement of shotcrete.
- The applied ventilation seal surface is to be cleaned thoroughly with pressured air and water to remove any loose material. Wait for the water to drain or absorb into the ventilation seal surface.
 - Re-apply a rinse-coating of water as a bonding agent to the ventilation seal until the entire surface has a wet-shine appearance.
 - Wait for the water to drain off or absorb into the ventilation seal surface before resuming the placement of shotcrete.
- 5.36 After application of shotcrete is complete, MSHA approved sealants may be applied if an air leak is detected.
- 5.37 Inspect the ventilation seal location area and remove any loose debris or foreign objects in direct line to the proposed ventilation seal location for 50’-0” outby from the proposed ventilation seal location.
- 5.38 Installation guidelines are considered “typical.” Site specific conditions may require minor changes to the installation. All changes will be certified by the Professional Engineer overseeing the installation.
- 5.39 Each ventilation seal is to be considered acceptable for convergence up to 1” of true convergence per foot of entry height, so long as no structural distress, such as spalling or excessive cracking is evidenced on the ventilation seal outby surface.
- 5.40 To measure mine convergence at each ventilation seal, a “pogo” stick measuring device will be installed in a center outby location of each ventilation seal.
- 5.41 If at any point in the future, the pogo stick measuring device indicates that more than 1” of convergence per foot of the entry height has occurred, the ventilation seal must be

MSHA Approval Number: 120M-09.1
120 PSI PMR Reinforced Concrete Seal 12ft X 40ft
Precision Mine Repair
For Information Contact Jeff Kearns or Jim Hise at 618.272.7220

Seal Installation Guidelines for the PMR Reinforced Concrete Main Line Seal

- inspected/evaluated by a licensed professional engineer to determine if true convergence has occurred and if the structural strength of the ventilation seal has been compromised.
- 5.42 However, where convergence occurs at a ventilation seal location due to floor heave as a result of the floor fracturing or deforming and displacing about the ventilation seal, then the floor heave material will need to be excavated as necessary to prevent interference with the function and integrity of the outby water drainage system pipe(s).

Other Notes

- Refer to Blast Seal Drawings Sheets 1 & 2 for complete details.

120-PSI 12ft x 40ft BLAST SEAL

For MSHA FINAL RULING

DETAIL

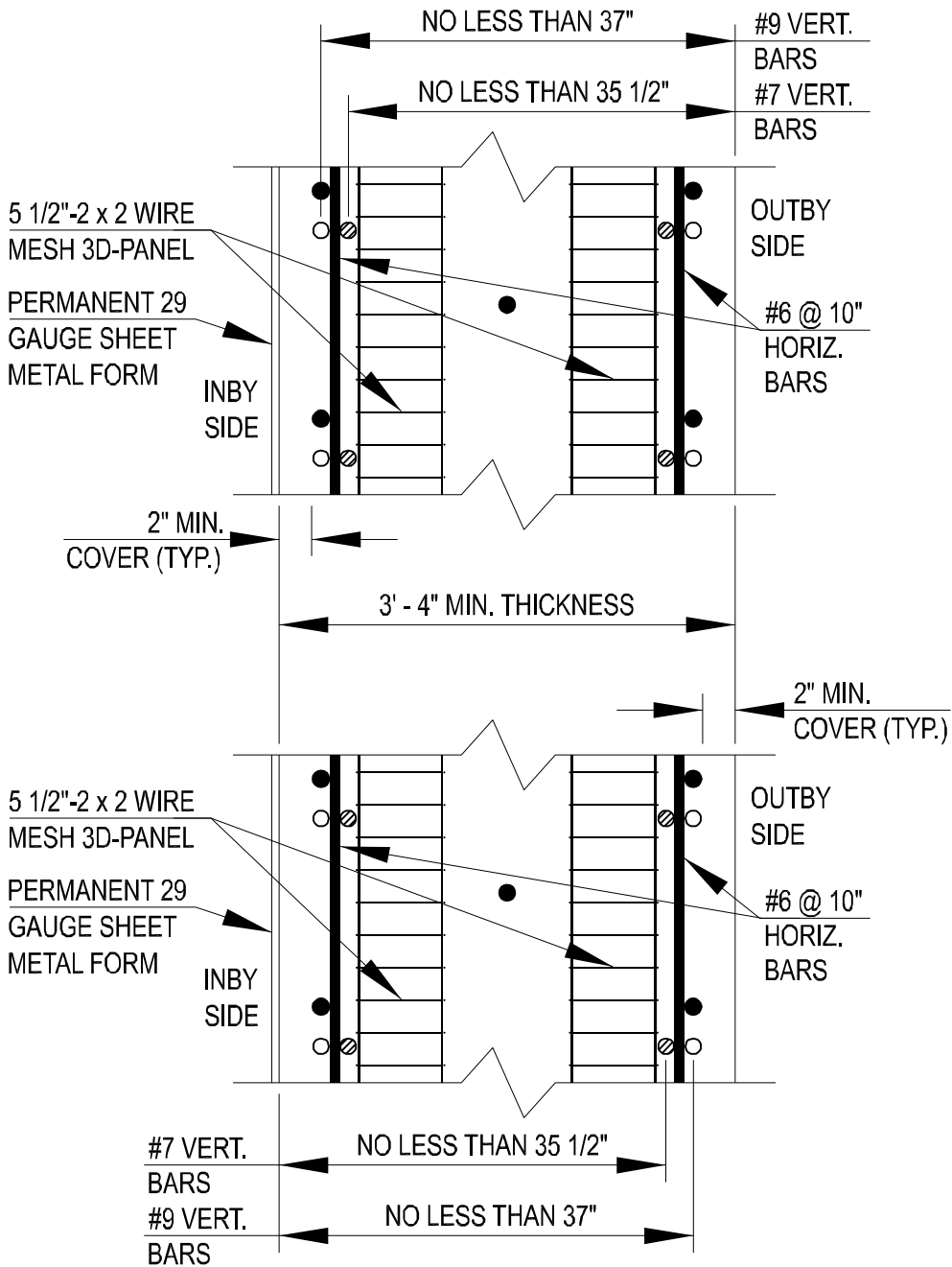

LEGEND

PLAN

- — #9 DOWELS @ 14"
- — #9 VERTICAL BARS @ 12"
- ⊗ — #7 VERTICAL BARS @ 12"

NOTE: STIRRUPS NOT SHOWN FOR CLARITY.



PRECISION MINE REPAIR
MINE CONSTRUCTION

705 W Main St.
Ridgeway, IL 62879
Office: 618-978-7880
Fax: 618-272-7155

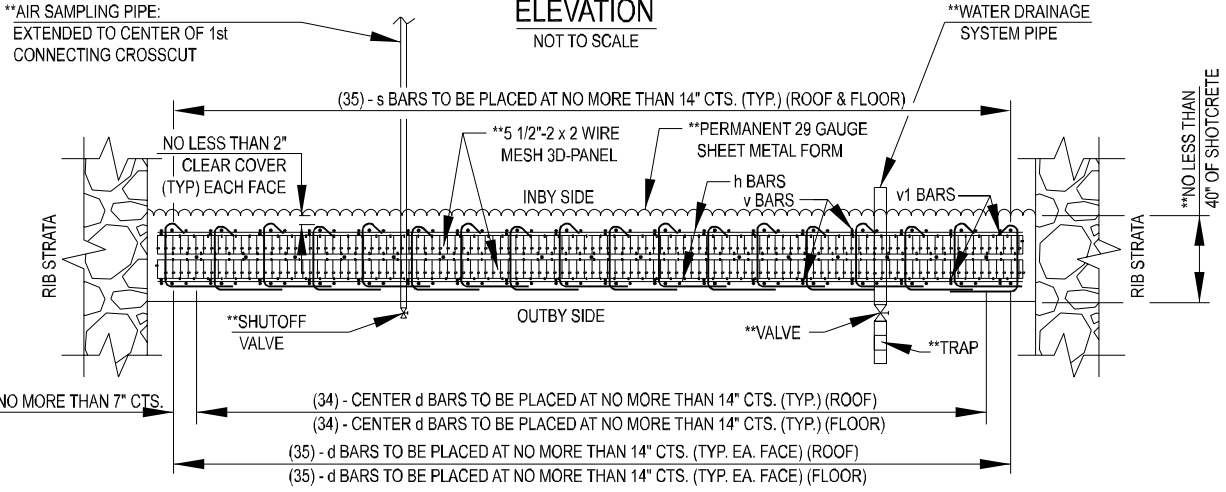
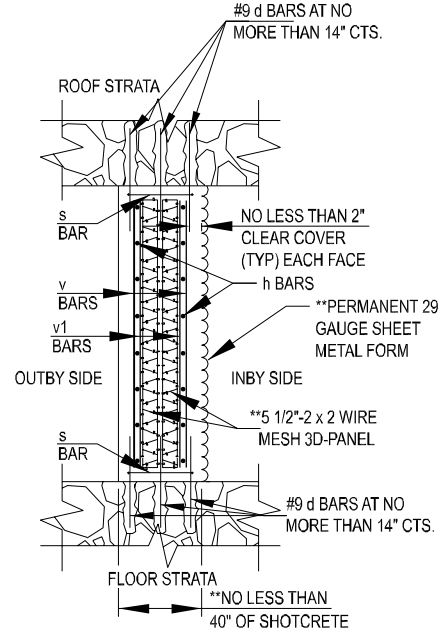
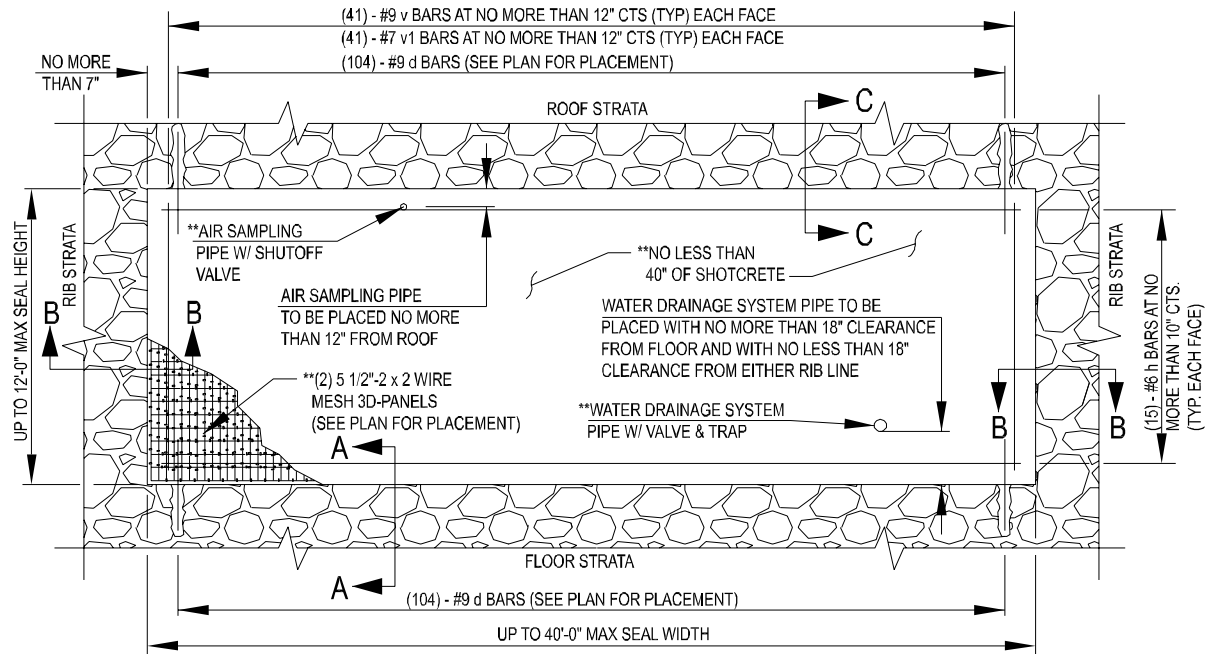

SIDE VIEW NOT TO SCALE

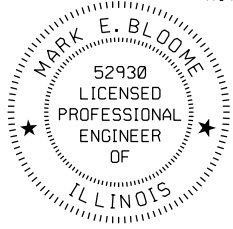

Mark E. Bloome

MARK E BLOOME
 DATE 8 / 21 / 2009
 LICENSE EXPIRES 11 / 30 / 2009



HR
 HURST-ROSCHÉ
 ENGINEERS INC.
 PROFESSIONAL ENGINEER LICENSE NO. 143508
 601 N BRUNS LANE, SUITE B
 SPRINGFIELD, IL
 PH: 217.737.1199
 F: 217.733.1199
 HILLSBORO, IL
 EAST ST. LOUIS, IL
 MARION, IL

MSHA Approval Number: 120M-09-1
 120 PSI PMR Reinforced Concrete Seal 12ft x 40ft
 For MSHA Final Ruling

MARK	DATE	DESCRIPTION

DATE: 8 / 21 / 2009
 PROJECT NO: 411-2070
 DESIGN: DRAWN: CHECK:
 MEB BLV JSP

120-PSI 12ft x 40ft
 BLAST SEAL

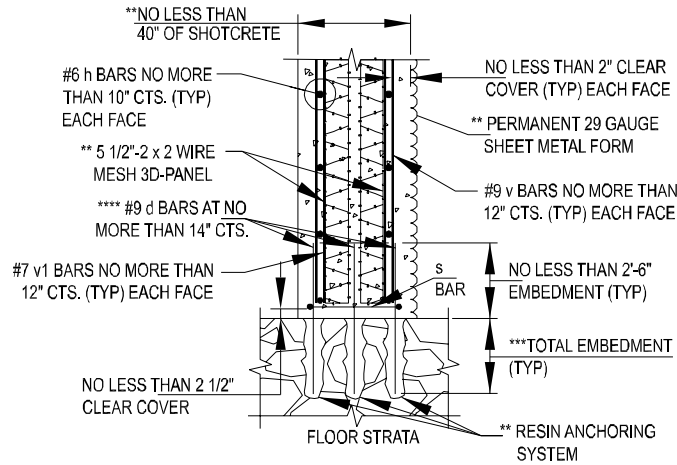

TYPICAL SECTION A-A
NOT TO SCALE

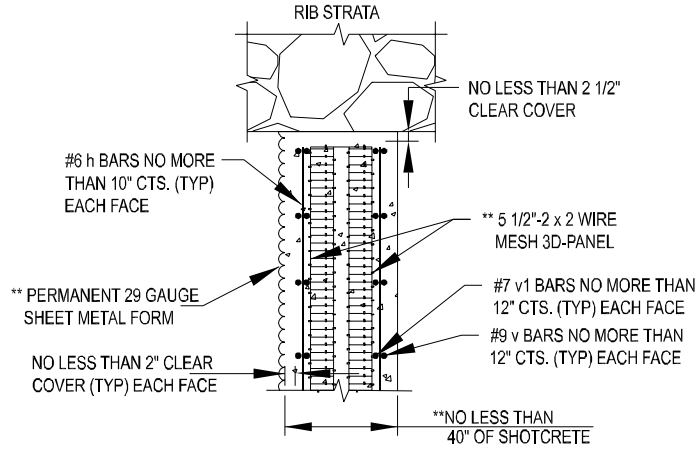

TYPICAL SECTION B-B
NOT TO SCALE

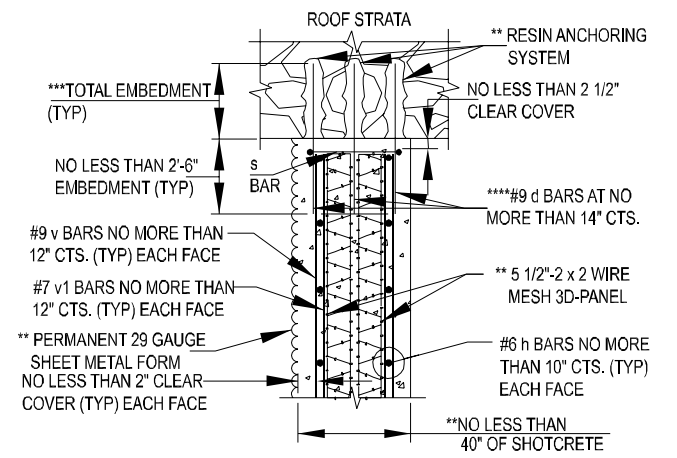

TYPICAL SECTION C-C
NOT TO SCALE

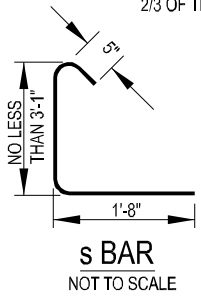

s BAR
NOT TO SCALE

GENERAL NOTES

TTO DECREASE THE POSSIBILITY OF PROJECTILE IMPACTS, ALL DEBRIS & FOREIGN OBJECTS IN DIRECT LINE TO THE PROPOSED SEAL ARE TO BE REMOVED 50' BOTH INBY & OUTBY FROM THE PROPOSED SEAL.

- ** SEE SEAL APPROVAL INFORMATION AND INSTALLATION INSTRUCTIONS FOR PRODUCT DATA. IF MORE THAN ONE DRAINAGE PIPE IS INSTALLED IN THE SEAL, THE HORIZONTAL DISTANCE BETWEEN THE PIPES IS NOT TO BE LESS THAN 3 FEET.
- *** TOTAL EMBEDMENT IS TO BE EQUAL TO OR GREATER THAN THE IN-MINE PULL TEST TO YIELD #9 DOWEL OR 1'-6" WHICHEVER IS GREATER.
- **** LENGTH OF #9 DOWEL IS EQUAL TO TOTAL EMBEDMENT PLUS 2'-6" DEVELOPMENT LENGTH INTO SHOTCRETE. USAGE OF COUPLERS ARE NOT ALLOWED ON THE VERTICAL BARS IN THE MIDDLE 2/3 OF THE SEAL HEIGHT.

MIN. BAR LAP

- #6 = 2'-7" (HORIZONTAL BARS)
- #9 = 3'-6" (VERTICAL BARS)
- #7 = 2'-1" (VERTICAL BARS)

DESIGN STRESSES

- f'c = No less than 4,500 psi (Shotcrete)
- fy = No less than 60,000 psi (Rebar)
- fy = No less than 60,000 psi (Wire Mesh)
- fy = No less than 60,000 psi (Couplers)

*BILL OF MATERIALS

Bar	No.	Size	Length	Shape
h	30	#6	39'-7"	—
v	82	#9	11'-7"	—
v1	82	#7	11'-7"	—
d	208	#9	****	—
s	70	#4	5'-2"	⌋

*FOR INFORMATION ONLY

PRECISION MINE REPAIR
MINE CONSTRUCTION
105 W. Maple St.
 Springfield, IL 62767
 (217) 787-1199
 Fax: (217) 793-1199

WORK THIS SHEET WITH SHEET 1 OF 2.

MSHA Approval Number: 120M-09-1
 120 PSI PMR Reinforced Concrete Seal 12ft x 40ft
 For MSHA Final Ruling

MARK	DATE	DESCRIPTION

DATE: 8/21/2009
 PROJECT NO: 411-2076
 DESIGNER: MEB DRAWN BY: BLV CHECKED BY: JSP

120-PSI 12ft x 40ft
BLAST SEAL