

**National Defense Reserve Fleet  
Anchorage Environmental  
Excellence Initiative Best  
Management Practices**

**June 18, 2009**

## **Introduction:**

In January of 2007, the Maritime Administrator directed the Agency to embark on an Environmental Excellence Initiative (EEI) to enhance the Agency's stewardship of the environment. Although the EEI is broad in scope, covering all Agency programs and operations, the initial emphasis was placed on the National Defense Reserve Fleet (NDRF) Program as its operations are viewed as those posing the highest risk of direct impacts to the environment. The Maritime Administration operates three reserve fleet anchorages commonly known as the Suisun Bay Reserve Fleet (SBRF), the Beaumont Reserve Fleet (BRF), and the James River Reserve Fleet (JRRF) (collectively the "Fleets"). The list of the vessels in these anchorages is updated monthly (National Defense Reserve Fleet Inventory) which includes the names of the vessels and the categories they occupy. In addition to the vessels in the anchorages, the Fleets have supporting waterfront and shoreside operations.

As part of an ongoing process, the Maritime Administration reviews all three Fleets and supporting waterfront and shoreside operations in an effort to identify operations, conditions, and processes that pose the greatest risks to the environment and to develop Best Management Practices (BMP) that would assist the Agency in reducing those risks. The Agency has engaged the assistance of outside environmental professionals and remains willing to listen to input for these BMPs from any responsible source, particularly the regulatory environmental officials from the States in which the Fleets reside. On May 26, 2008, the first EEI BMPs were approved and on July 9, 2008 they began to be implemented.

The Maritime Administration's role as the disposal agency for government owned vessels includes the responsibility for longer-term management and maintenance of those vessels pending disposal. In performing this review, it became evident that the majority of the risks to the environment stem from the challenges the Agency has faced with respect to the pace of disposal of non-retention ships. Many of the key BMPs focus on activities related to the vessels themselves. In that regard, the Maritime Administration continues to believe that the best method for limiting risks to the environment and expending public resources is to remove as quickly as possible the non-retention vessels from the fleet sites entirely.

Blending the Agency's ship operations, management, and disposal experience with the insights and experience of the environmental professionals, the Maritime Administration has identified the BMPs set out below.

These BMPs do not cover all of the details concerning their implementation. Specific process and actions will be the subject of each Fleets' more detailed Environmental Management System (EMS).

### **1.0 Implementation**

BMP details will be recorded in the Fleets' EMS, which will document the processes for managing and tracking environmental performance at the Fleets. An EMS also provides a

method for regularly reviewing and improving performance by implementing appropriate environmentally related structural or procedural changes. It will provide a mechanism for centralizing fleet-wide procedures, as appropriate, and maintaining environmental documentation to meet Maritime Administration, and Department of Transportation information needs.

Waivers for BMPs will be considered for approval upon providing written justification. Approval will not be given for procedures that harm the environment or do not conform to law regardless of justification. Justification documentation will be approved by the Director, Office of Ship Operations and kept on file in accordance with records management guidance.

## **2.0 Best Management Practices**

### **2.1 Vessel Arrival**

Vessels will be inspected and prepared for arrival at the Fleets. Vessel arrival procedures are explicit in the instructions to form MA-496. The form is also used to ensure that customers using the anchorage services provided by the Maritime Administration prepare their vessels to the described standards. The vessel arrival BMPs will ensure that all vessels arriving at the Fleets are subject to the same minimum preparation standards.

- 2.1.1 Pre-arrival inspections will be scheduled and performed at an appropriate off-site location prior to vessel arrivals at the Fleets to identify and document any critical discrepancies. Before arrival, the following actions will occur.
  - 2.1.1.1 Except for in-class operational vessels or where the vessel entering the Fleet has come from the same biological area as the applicable fleet so that there is no danger of Aquatic Invasive Species with respect to that Fleet, documentation will be provided showing that underwater hull cleaning of biological growth has occurred during preparations for arrival at a Fleet anchorage.
  - 2.1.1.2 Hydraulic cargo gear machinery on deck will be maintained in a leak free condition and will be provided with appropriate secondary containment.
  - 2.1.1.3 Reasonable efforts will have been undertaken so that debris and exfoliated paint will have been removed from the weather decks.
  - 2.1.1.4 All vessel strainers, pump casings, drain tanks, hydraulic lines and service tanks in a vessel's interior spaces will be maintained in a leak free condition.
  - 2.1.1.5 Reserved
  - 2.1.1.6 All interior spaces, including engine and boiler rooms, will be thoroughly cleaned to remove dirt, loose paint and scale, oil, grease, water, debris, and other foreign materials.
  - 2.1.1.7 Except for in-class operational vessels, tanks containing petroleum products, slops and contaminated liquid ballast will have had their content removed to low suction. In-class operational vessels will consolidate fuels to internal tanks that do not use the hull for any part of the tank walls.
  - 2.1.1.8 Drip pans containing petroleum products, slops and contaminated liquids will have been cleaned.

- 2.1.1.9 All damaged or deteriorated asbestos will have been removed or encapsulated so as to prevent the spread of airborne asbestos fibers.
- 2.1.1.10 Vessel deck houses, engine room access, and cargo hold hatches will be sealed to prevent rain water intrusion and prevent birds from nesting on interior structures. In some cases, dehumidification of interior spaces will be provided to enhance long-term preservation.
- 2.1.1.11 Except for in-class operational vessels, external hull blanks will be installed to positively close underwater hull penetrations normally used to provide water in support of engine room machinery.
- 2.1.1.12 Stern glands will be made watertight, will have sufficient packing in support of future tightening, will have oil lubricated stern bearing sealing systems serviced with reservoirs and tanks filled, and will ensure that sealing systems are leak free.
- 2.1.1.13 All containerized hazardous materials not necessary for maintenance or preservation of the vessels will have been removed and an inventory of all containerized hazardous materials that remain on board will be provided. The inventory will include, names, quantities, locations, and purchase and expiration dates, as appropriate. This inventory will be included in Emergency Response Plans to update them as necessary.
- 2.1.1.14 Material Safety Data Sheets for inventoried hazardous materials will be provided.
- 2.1.1.15 Appropriate storage of the remaining inventoried hazardous materials will have been provided with secondary containment systems to ensure there is a back-up barrier capable of preventing releases of hazardous materials into the water.
- 2.1.1.16 Except for in-class operational vessels, an arrival hazardous material survey report will be provided for all structures and equipment showing a thorough analysis of hazardous material. The report will include:
  - 2.1.1.16.1 Airborne asbestos sampling results and location of sampling points;
  - 2.1.1.16.2 Results of radiological monitoring;
  - 2.1.1.16.3 PCB (non-liquid media) sampling results and an inventory of equipment potentially containing liquid PCBs;
  - 2.1.1.16.4 Mercury survey results;
  - 2.1.1.16.5 Sodium chromate survey of tanks;
  - 2.1.1.16.6 An inventory of ozone depleting substances;
  - 2.1.1.16.7 A descriptive report of external paint coating systems and the last date of large-scale coating application;
  - 2.1.1.16.8 Location and types of permanent ballast; and
  - 2.1.1.16.9 Tank soundings.
- 2.1.2 Arrival inspections will take place upon vessel arrivals at the Fleets to identify and document vessel arrival condition relative to cleanliness, orderliness, sanitation, security, status of hazardous materials, water tight integrity, and safety.
  - 2.1.2.1 Upon arrival, a vessel's exterior surfaces will be free of heavy scale and loose or flaking paint. In cases where heavy scale and loose or flaking paint are not removed, the surface will have been encapsulated in a manner

- that will last at least five years.
- 2.1.3 Soon after arrival, except for in-class operational vessels or vessels that are going to be retained for future operation and put into a readiness state, vessels will be prepared for long-term storage.
    - 2.1.3.1 After arrival, scupper strainers will be installed and all scupper deck drains will be cleared of debris and working properly.
    - 2.1.3.2 After arrival, an impressed current cathodic protection system will be installed to slow underwater hull deterioration.

## **2.2 Vessel Maintenance**

An essential component of the EEI BMPs is maintaining an effective level of environmental stewardship during the vessel maintenance cycle. Although a substantial inspection system for protection of the environment currently exists at the Fleets, a more rigorous set of inspections will augment the maintenance actions taken on a given vessel. These inspections will be documented and findings will be reported to management.

NDRF vessels are owned by the Maritime Administration and are maintained as dictated by the performance-based Fleet Contract. Other federal government agency customers that take advantage of the services provided by the Fleet anchorages are governed by the instructions to form MA-496. This provides for the establishment of specific maintenance requirements that are to be performed. In some cases, a memorandum of agreement with the federal government agency customer provides for additional specific maintenance activities associated with the vessel or other property at the Fleet. With respect to vessels owned by the Maritime Administration, maintenance will include at least the following:

- 2.2.1 A Vessel Condition Summary Report will be updated quarterly. The summary is a compilation of several sources of information that are accumulated over the course of preservation system maintenance. It contains information on the overall hull condition, hull spot corrosion, the amount of fuel on board, the overall interior condition, and the overall topside condition, including the amount of deteriorated paint coatings. MA-279 Vessel Condition Survey Reports record survey inspection data when vessels arrive and depart, and upon significant condition changes.
- 2.2.2 On retention vessels and in-class operational vessels, all equipment strainers, pump casings, drain tanks and service tanks will be maintained in leak-free condition.
- 2.2.3 On non-retention vessels, all equipment strainers, pump casings, drain tanks and service tanks will be inspected to ensure there are no residues from the drained system openings.
- 2.2.4 All vessel equipment strainers, pump casings, drain tanks and service tanks will be maintained leak free.
- 2.2.5 Where ship equipment is removed for other operational or historic purposes, bilges and surrounding floor plates will be cleaned and hazardous materials inventories will be updated.
- 2.2.6 Secondary containment systems will be inspected regularly and maintained,

- especially prior to and after storm events.
- 2.2.7 Decks will be maintained such that loose debris is collected and removed from the vessel.
  - 2.2.8 Deck drain scuppers and screens will be kept clean and free of debris.
  - 2.2.9 Hull gauging will be conducted on a regular basis according to a vessel's hull condition to assist in determining the overall condition of the hull. Hull-gauging surveys will be conducted at up to 50 specified locations on each ship semi-annually for hull condition 0 – 2, annually for hull condition 3 – 4, and biannually for hull condition 5.
  - 2.2.10 All ships will have flood alarm sensors that detect flooding in the bilges of engineering spaces and any spaces that have sea connections. The sensors will trip alarms that can be seen and heard at a manned location. Flooding marks are painted on the hull at the bow and stern waterline and maintained. They are also monitored by waterborne security daily.
  - 2.2.11 Dewatering will be accomplished on ships to remove accumulated water in bilges and cargo holds. Machinery space bilges will have less than six inches of liquid and cargo hold bilge wells will have less than twelve inches of liquid.
  - 2.2.12 Hull and topside watertight leaks will be repaired.
  - 2.2.13 An impressed current cathodic protection system will be maintained to enhance hull preservation.
  - 2.2.14 Exterior coatings will be maintained to prevent releases of exfoliated paint into the local waterways.
    - 2.2.14.1 A coatings condition report will be prepared to identify those vessels at risk for releasing exfoliated paint and to prioritize the severity of the risk.
    - 2.2.14.2 Vessels with the worst freeboard and topside coatings condition will be remediated first and a monitoring schedule will be developed to plan for additional remediation of the remaining painted surfaces.
    - 2.2.14.3 A ship's sponsor making arrangements for custody of a vessel in a Fleet anchorage will agree on a schedule for coatings maintenance before the vessel arrives to ensure that coatings are maintained and are not released.
  - 2.2.15 Interior conditions will be monitored through regular inspections to ensure awareness of hazardous material spills and to maintain good housekeeping.
  - 2.2.16 Hazardous materials will be monitored so they remain identified and properly stowed.
  - 2.2.17 The condition of hazardous materials containers will be inspected and deteriorated containers and their contents will be removed and properly disposed.
  - 2.2.18 Outdated hazardous materials will be properly removed and disposed on a regular basis.
  - 2.2.19 Hazardous material inventories will be updated as materials are added to storage areas, used or disposed.
  - 2.2.20 Emergency response kits and equipment will be provided at hazardous material storage areas and maintained in good condition.
  - 2.2.21 Fuel remaining on vessels in the Fleets will be essentially removed through the process of ship disposal. Additionally, vessel condition will be monitored to manage the risk of releasing fuel oil. The following management and

condition variables will be considered to determine the need to remove fuel before a vessel is removed for disposal: the period of time before removal for disposal will occur, the amount of fuel on a vessel, the type of fuel on a vessel, the location of fuel, and the vessel's hull condition.

## **2.3 Vessel Departure**

Vessel departure procedures are followed when a vessel is to be removed from a Fleet anchorage. Preparations are made relative to the expected weather conditions where lines connected to other vessels may be removed or singled, anchors may be broke free of the bottom, electrical power cables may be removed, equipment and materials inventories are reviewed, and seaworthiness may be increased by stowage of items and strengthening of various components. On the day of scheduled departure, anchors are stowed, wires are disconnected, lines to other vessels are removed, and tugs pull the ship from its mooring row. The following activities will also occur:

- 2.3.1 Except for in-class operational vessels, all containerized hazardous materials not necessary for maintenance during towing or for further operational use of the vessel will be removed and, if disposed of, it shall be disposed of in accordance with applicable federal, state, and local law.
- 2.3.2 Loose paint and any debris that may have accumulated between maintenance activities will be collected and removed prior to retrieving anchor chains and electrical cable and, when disposed of, it shall be disposed of in accordance with applicable federal, state, and local law..
- 2.3.3 Anchor chain and electrical cables will be washed to remove sediment and biological growth.
- 2.3.4 A copy of the containerized hazardous materials inventory will be provided upon delivery to the vessel recipient.
- 2.3.5 A copy of the arrival hazardous material survey on structures and equipment will be provided upon delivery to the vessel recipient.
- 2.3.6 Except for in-class operational vessels, all vessels departing Fleet anchorages will have their underwater hulls cleaned of biological growth before departing the local biogeographic area. Hull cleaning may or may not occur at a Fleet anchorage location.

## **2.4 Safety Management and Emergency Response**

- 2.4.1 Spill Prevention Control and Countermeasures Plans (SPCCP) and Oil Spill Response Plans (OSRP) will be designed to facilitate quick action in addressing spills of hazardous materials and petroleum to limit the severity of spills and implement appropriate remedial actions. The plans will be reviewed at least annually and updated as necessary with current hazardous material inventories.
- 2.4.2 The OSRP will incorporate the capabilities of the RRF/NDRF Vessel Oil Spill Insurance contract where processes exist to rapidly employ a Spill Management Team that can take measures to control Fleet spills.

- 2.4.3 The Fuel Oil Transfer Plans (FOTP) will document how to conduct fuel oil transfers to and from shoreside above-ground storage tanks (ASTs), and to equipment with integrated fuel tanks. It contains both general transfer procedures that apply to all transfers conducted onshore and unique procedures written for specific locations. Fuel oil transfer procedures and related checklists and postings will require that some form of secondary containment be provided for tanker trucks delivering fuel or vacuum trucks removing used oil and bilge water.
- 2.4.4 The FOTP will be amended to specify providing secondary containment by portable spill containment curbing placed around a truck during transfer operations and a spill kit that is appropriate for onshore oil response operations will be readily available during all transfers.
- 2.4.5 The FOTP will be reviewed at least annually and updated as appropriate based on US Coast Guard and OSHA guidelines.
- 2.4.6 Stormwater Pollution Prevention Plans (SWPPP) will establish measures to formalize the methods of preventing rainwater from washing materials into land areas and from the decks of ships. It will be reviewed at least annually and updated as appropriate.
- 2.4.7 Emergency response plans will incorporate updated versions of hazardous material inventories.

## **2.5 Shoreside Operations**

Shoreside operations occur on the land-based areas of each Fleet, which do not include the service craft piers that extend over the water. This group is consolidated because the potential contaminant release mechanisms could affect the land areas surrounding the property being used by the Fleets. These properties are close to navigable waterways, so the potential also exists for materials releases into those waterways. Preventative measures to help control land-based releases are similar in nature.

- 2.5.1 All shoreside fuel oil transfers will be conducted in accordance with the FOTP.
- 2.5.2 An inventory report of shoreside hazardous materials and containers will be maintained.
- 2.5.3 Management of shoreside hazardous materials and petroleum products will be based on Fleet specific inventory usage and operational requirements and include provisions for gathering, staging, and properly disposing of outdated and obsolete hazardous materials.
- 2.5.4 An inspection procedure will be established for tracking the amount and condition of shoreside hazardous materials and petroleum products and their containers.
  - 2.5.4.1 Monthly documented inspections of all shoreside containers, especially those for holding liquids of 30 gallons or more will be conducted. The inspections will ensure that containers are properly labeled, have operating alarm systems, as appropriate, and have proper secondary containment if they hold hazardous materials or petroleum products. This requirement



includes underground storage tanks (USTs), above ground storage tanks (ASTs), and equipment with integrated fuel tanks, such as transformers and emergency generators. Monthly inspections will be performed based on industry standards, including American Petroleum Institute Standard 653 (API 653) and Steel Tank Institute standard SP001. A site-specific checklist will be required to document the inspections.

- 2.5.5 Shoreside hazardous materials will be consolidated at points of use (POUs) where materials are needed and appropriate secondary containment will be provided. To the extent possible, the amount of material stored at the POU will be limited to that necessary to perform the work being undertaken and procedures will be established to prevent unsupervised movement of hazardous materials to various work locations. Upon completion of the work, unused materials will be returned to a long-term storage location or properly disposed. The POUs will be provided with adequate containment, a spill kit, and protection from the weather. A process for safely moving the items to the POUs will be established.
- 2.5.6 All hazardous materials and petroleum products will be stored within secondary containment structures. This includes providing secondary containment for single-walled ASTs and equipment with integrated, single-walled fuel tanks, such as transformers and emergency generators. Secondary containment may include double-walled ASTs, permanent secondary containment structures, temporary secondary containment structures, or placing smaller containers in a hazardous materials storage locker or on a spill containment pallet. The holding capacity of the secondary containment will not be compromised by the stored items. Secondary containment structures will be protected from the weather, well maintained, and free of debris.
- 2.5.7 A monitoring and maintenance process will be established to track the condition of portable metal transfer ASTs and hazardous materials storage lockers. The process will include documented routine inspections and maintenance activities to prevent corrosion.
- 2.5.8 Shoreside hazardous materials storage lockers and ASTs that show signs of wear will be replaced or repaired.
- 2.5.9 Portable storage equipment, including hazardous materials storage lockers and cabinets not designed for extended external use, will be located in covered areas and protected from the weather.
- 2.5.10 Equipment containing oil or hazardous materials, including forklifts, tractors, and other fleet service vehicles, will be stored on concrete and provided with drip pans or other secondary containment and protection from the weather.
- 2.5.11 All piping between ASTs and associated emergency generators will be durable, fixed, sturdy enough to withstand the weather, protected from impact, compatible with the product stored and double-walled or equipped with secondary containment.
- 2.5.12 Emergency shutoffs and locks will be provided for all pumps dispensing gasoline, diesel fuel, or other hazardous materials.
- 2.5.13 Barrier protection for all ASTs will be provided, including permanently installed equipment with integrated fuel tanks, such as transformers and emergency generators that are located near vehicular traffic areas to prevent

- vehicles from accidentally damaging the ASTs.
- 2.5.14 Secondary containment and protection from the weather will be provided for all hazardous material drums by either placing these drums on secondary containment pallets in a covered area protected from the weather or placing them in a hazardous material storage locker designed for extended outdoor use.
  - 2.5.15 Procedures will be employed to ensure materials stored within each shoreside hazardous materials storage locker or storage area are compatible and good housekeeping practices will be maintained to ensure the integrity of the storage lockers or areas.
  - 2.5.16 All old, obsolete, out-of-date, or unneeded hazardous materials and petroleum products will be removed and properly disposed on a regular basis in accordance with applicable federal, state, and local law.. Hazardous material stores will be reviewed at least annually for appropriate characterization and handling.
  - 2.5.17 All empty drums will be disposed in a timely manner after they are emptied. Empty drums that contained hazardous materials or petroleum products will be stored within secondary containment areas until properly disposed.
  - 2.5.18 An equipment decommissioning procedure will be provided to ensure that equipment with integrated fuel tanks, such as forklifts, are adequately contained or protected from causing a release while awaiting disposal.
  - 2.5.19 Site stormwater will be managed in a manner that does not permit it to drain directly to adjacent wetlands or sensitive areas by installing or constructing stormwater detention systems and following the storm water pollution prevention plan.

## **2.6 Waterfront Operations**

Waterfront operations are associated with those operational areas at the Fleets that are over water, such as materials storage barges, and service craft. Some ships are located in a Fleet anchorage temporarily and require special treatment because they are in-class and operational. The service craft piers are also included in this section. This group is consolidated because the most prevalent potential contaminant release mechanisms may directly affect the waterways used by associated equipments and structures.

- 2.6.1 All waterfront fuel oil transfers will be conducted in accordance with the FOTP.
- 2.6.2 An inventory report of waterfront hazardous materials and containers will be maintained.
- 2.6.3 Management of waterfront hazardous materials and petroleum products will be based on Fleet specific inventory usage and operational requirements and include provisions for gathering, staging, and properly disposing of outdated and obsolete hazardous materials.
- 2.6.4 An inspection procedure will be established for tracking the amount and condition of waterfront hazardous materials and petroleum products and their containers.

- 2.6.4.1 Monthly documented inspections of all waterfront containers, especially those for holding liquids of 30 gallons or more will be conducted. The inspections will ensure that containers are properly labeled, have operating alarm systems, as appropriate, and have proper secondary containment if they hold hazardous materials or petroleum products. This requirement includes underground storage tanks (USTs), above ground storage tanks (ASTs), and equipment with integrated fuel tanks, such as transformers and emergency generators. Monthly inspections will be performed based on industry standards, including American Petroleum Institute Standard 653 (API 653) and Steel Tank Institute standard SP001. A site-specific checklist will be required to document the inspections.
- 2.6.5 Waterfront hazardous materials will be consolidated at points of use (POUs) where materials are needed and appropriate secondary containment will be provided. To the extent possible, the amount of material stored at the POU will be limited to that necessary to perform the work being undertaken and procedures will be established to prevent unsupervised movement of hazardous materials to various work locations. Upon completion of the work, unused materials will be returned to a long-term storage location or properly disposed. The POUs will be provided with adequate containment, a spill kit, and protection from the weather. A process for safely moving the items to the POUs will be established.
- 2.6.6 Except as provided for POU storage, waterfront hazardous materials will be moved to shoreside storage locations, where appropriate. Hazardous materials being readied for disposal will be moved to shoreside storage locations. Hazardous materials being collected and made ready for disposal or movement to shoreside storage locations will be consolidated and contained in 30-gallon and larger hazardous waste storage drums and stored in locations with one of the following secondary containment features: a welded or prefabricated curb or a prefabricated continuous secondary containment structure, or in portable hazardous material storage lockers. The storage locations will be protected from the weather, stabilized to prevent motion, and maintained to prevent corrosion.
- 2.6.7 Procedures will be employed to ensure materials stored within each waterfront hazardous materials storage locker or storage area are compatible and good housekeeping practices will be maintained to ensure the integrity of the storage lockers or areas.
- 2.6.8 A monitoring and maintenance procedure and schedule for inspecting and maintaining portable metal transfer ASTs and hazardous materials storage lockers will be developed to ensure that they remain in good condition. The procedure will include documented routine inspections and require repainting or other measures to protect against corrosion.
- 2.6.9 Waterfront hazardous materials storage lockers and ASTs that show signs of wear will be repaired or replaced.
- 2.6.10 Equipment containing oil or hazardous materials will be provided with drip pans or other secondary containment protected from the weather.
- 2.6.11 Batteries awaiting recharge will be placed in prefabricated secondary containment structures protected from the weather.

- 2.6.12 All batteries will be recharged either in place on equipment or within prefabricated secondary containment structures.
- 2.6.13 All temporary transfer tanks that are not double-walled will be provided with secondary containment structures that have lockable drainage ports.
- 2.6.14 Hazardous materials storage lockers or secondary containment will be provided for all petroleum hydrocarbon products and hazardous materials used regularly in waterfront repair shop areas.
- 2.6.15 During fleet service craft preparation for painting, techniques will be used to contain paint-related debris.
- 2.6.16 Procedures to be used during fleet service craft painting operations will prevent paint and associated material from entering the water.
- 2.6.17 Service craft bilge water will be monitored for the presence of petroleum products and the bilge water log for each service craft will be monitored for abnormal fluctuations. Spill containment equipment, including an oil containment boom, will be readily available during service craft bilge water discharge operations.
- 2.6.18 All old, obsolete, out-of-date, and unneeded hazardous materials stored in waterfront areas will be removed and properly disposed in accordance with applicable federal, state, and local law.
- 2.6.19 All unneeded waterfront ASTs will be removed and properly disposed in accordance with applicable federal, state, and local law.
- 2.6.20 A waterfront equipment decommissioning procedure will be established to ensure that equipment with integrated fuel tanks, such as generators, are adequately contained or protected from causing a release while awaiting disposal.
- 2.6.21 Pier MHE and vehicles will be stored on pads out of the weather. Oil-filled and fuel driven equipment stored on a pier will be provided with secondary containment, such as a small shed with a ramped entry and recessed floor.
- 2.6.22 Vehicle pier parking for visitors and deliveries will be restricted to a maximum of 30 minutes, and the guard at the site entrance will inspect those vehicles for leaks before allowing them to be driven onto the pier.

# Appendix 1 Exfoliated Paint Removal Operations

Exterior exfoliated paint can be maintained to prevent loose paint from entering the water where the ships are anchored. This could be done by removal and disposal of the paint or encapsulation of the paint with a new coating. A combination of both processes is also possible where paint is partially removed to provide an adhesive surface for overcoating with an encapsulating material. The expected variety of practical paint removal options will be considered in a best value process to determine the use of government workforce and commercial contractor services or the mix of both. Selected approaches will depend on a number of factors including vessel location and condition, weather associated with the Fleet anchorages, and cost.

The Maritime Administration shall inspect each of its non-retention vessels regularly to assess the condition of exterior coatings and report on the findings quarterly. Until a NPDES permit is received or other approval is obtained from the appropriate State Regulatory officials, the Agency will only use its government workforce to remove deteriorated paint from vessels where obvious improvements to discharge risk is attained while the vessels are at anchor. Preparations will be made for contractor assistance to clean vessels of deteriorated paint while located in the anchorage or at a drydock facility as necessary.

A review of potentially available technologies for addressing loose paint is discussed below. .

## **Surface Preparation**

Surface preparation is the practice of removing loose paint and metal residue or scale from the hull's freeboard and topside. Surface preparation processes that may be viable for the Fleets include abrasive blasting, vacuuming, adhesive paint removers, and manual multi-brush scraping.

A vacuum system has the advantage of removing loose paint and collecting it at the same time. A fully contained vacuum robot system, such as the Unibot Vac Robo System, has been used for metal surface preparation for comparable applications. According to Showa Rubber Company, Ltd., owners of Unibot, Unibot has been successfully used on vessel freeboard and topside surface preparation. The removed paint and metal residue is contained within the vacuum enclosure. Unibot reportedly creates no fugitive dust or contaminated water because it is attached to recycling and filtration units that separate and recycle water, abrasive grit (if used), and debris. The Unibot can work up to 600 vertical feet and 300 horizontal feet from the joy stick controller, potentially reducing or eliminating the need for moving the Fleet anchored vessels farther apart. Similar robot systems are also available, such as the En-Vac Robotic Wall Scabblor, which works on concrete surfaces.

If polyurea-based spray-on materials are used to contain the exfoliating paint, a manual surface preparation that combines vacuuming, hand grinding, and priming to prepare the freeboard and topsides for overcoating could be used. Loose paint would be removed from the surface by hand grinding. High power vacuums would capture most of the exfoliating paint, although additional containment would be necessary. In order to prepare the surface for the polyurea application, approximately 10 percent of the surface would be manually abraded to create adhesion points for the polyurea (Performance Foam, Inc. 2007).

A paint remover could have effective and efficient qualities. Paint removers suitable for surface preparation include a variety of products, such as Peel Away Marine Safety Strip (Marine Strip) I and II, manufactured by Dumond Hazardous materials, Inc. Both products have been used successfully in smaller scale marine applications on fiberglass, wood, and metal (although Marine Strip II cannot be used on aluminum). Both products remove up to ten layers of paint in one application; however, Marine Strip II will leave intact any epoxy barrier coat. Although both products are less toxic than other commercial paint removers, they contain hazardous materials, and containment measures must be taken during application. Marine Strip products are applied by roller or sprayer, covered with cloth, allowed to remain in place for approximately 24 hours and stripped with a scraper. A second application may be necessary if some paint remains. Marine Strip products do not penetrate the hull fiberglass gel coat commonly found on private recreational boats. This method might be excessively time-consuming for large surface areas, such as those of 1,000 square feet or more.

Multibrush scraping has proven traditional competencies. Multibrush scraping is a manual process similar to vacuuming and hand grinding but with different equipment. The pneumatic or electric cleaning brushes are designed, configured, and operated to achieve the necessary level of surface preparation. Containment would be required to prevent the paint residue from entering the water.

### **Overcoating**

Overcoating is the practice of coating the exposed vessel freeboard and topside surfaces with paint or a sealant product to prevent paint exfoliation. Overcoating processes that may be viable for the Fleets include penetrating primer, marine paint, and spray-on polyurea.

Polyurea refers to a polymer technology that has been used successfully to overcoat ship hulls, decks, and superstructures. Polyurea is a hazardous material that is generated when a polyurethane resin reacts with an epoxy curative (Polyurea.com 2005). The level of hazardous material formulation of polyurea depends on the application; a qualified chemist must be consulted to prepare an appropriate formulation for each job. Proper surface preparation is also very important to ensure the desired bond strength of polyurea. Polyurea cures quickly and is usually dry to the touch within seconds and often fully cured within 48 hours. Polyurea may be applied at a large range of ambient temperatures and humidity conditions. Polyurea does not contain volatile organic compounds or solvents (Performance Foam, Inc. 2007).

A certain minimum horizontal clearance would be required between vessels to provide access for a barge containing application equipment. Another way of applying the spray-on type coating is via a platform lowered over the side from above. The containment process includes attaching netting, tarp, and containment booms to contain any falling debris, vacuuming and priming the surface, and applying the polyurea overcoat. Surface preparation would be done at circular spots on a ten-foot grid where the polyurea would attach, so the material could span 100 square foot painted areas.

A variety of marine paints and primers are available commercially. Marine primers and paint are common methods of overcoating small and large boats. Primer and paint would be applied manually using sprayers or rollers.

## **Containment**

Different containment methods may be applicable to the processes involved in surface preparation and overcoating. Containment refers to the practice of encapsulating the work area and surroundings during surface preparation to avoid releasing exfoliated paint and metal residue into the environment. While vacuum systems could be used to contain most emissions, surface preparation methods will require additional containment. The specific containment methods reviewed are freeboard netting/tarpping and localized tenting/netting, and booms for containing floating materials.

Freeboard netting has a mesh material fine enough to contain paint, is attached to the vessel hull and is moved around the vessel as work progresses. Determining how to attach and reposition the netting effectively during the work should be tested. Care must be taken in securing the netting to the top and bottom of the freeboard area to avoid compromising the containment system during variable wind conditions.

Localized tenting/netting could be applied to confined work. It is possible that netting similar to that described above but confined closer to the work area could be installed. Testing would be necessary to determine how to attach the netting effectively and to move it efficiently.

A containment boom is similar to a curtain inserted into water that forms a gate around debris. Containment booms are typically used to contain oil but can also contain other floating debris. When operations are complete, the boom is reeled in and the debris is collected and disposed. A containment boom would not be effective on paint chips if they are not buoyant.

# INSTRUCTIONS TO FORM MA-496

## REQUIREMENTS FOR SPONSORS OF VESSELS HELD IN THE NATIONAL DEFENSE RESERVE FLEET (NDRF) SITES

**It is intended that all requirements herein be met by the Sponsor for vessel acceptance and lay up in the Reserve Fleet. However, some requirements may not be applicable to some vessels due to design, Sponsor, or mission of vessel. For those items that the Sponsor believes are not applicable, the Sponsor may submit a formal request for waiver of those specific items to MARAD, describing in detail the reason why they believe the item(s) is/are not applicable. Marad will review the waiver request and make a determination on a case-by-case basis. Sponsor should include all items to be considered for waiver in one submission so as not to delay the process.**

This document supersedes all earlier editions of Form MA-496 and replaces the MA-496A in its entirety.

Maritime Administration  
Office of Ship Operations  
Division of Sealift Operations, MAR-612  
May 21, 2009



## CONTENTS

### 1. General

- 1.1 Purpose
- 1.2 Eligible Vessel Types
- 1.3 Preliminary Acceptance and Restrictions
- 1.4 Preliminary Requirements
- 1.5 Final Acceptance
- 1.6 Delivery to the NDRF
- 1.7 Berthing and Layup Expenses
- 1.8 Custodial and Preservation Costs
- 1.9 Pre-Arrival Inspection
- 1.10 Arrival Inspection
- 1.11 Stripping at Fleet Sites
- 1.12 Title Transfer
- 1.13 Typical Order of Events

### 2. Definitions and Abbreviations

- 2.1 Retention
- 2.2 Non-Retention
- 2.3 Stowage
- 2.4 Deactivation
- 2.5 NDRF
- 2.6 D/H
- 2.7 C/P
- 2.8 MARAD
- 2.9 Layup Requirements
- 2.10 NDRF Desirable
- 2.11 Deferred Items
- 2.12 Sponsor
- 2.13 Short Term
- 2.14 Long Term
- 2.15 Preservation
- 2.16 Memorandum of Agreement
- 2.17 Hazardous Material
- 2.18 Hazardous Waste
- 2.19 Stripping
- 2.20 Cannibalization
- 2.21 Chief, Division of Sealift Operations (MAR-612)
- 2.22 Ship Operations and Maintenance Officer (SOMO)
- 2.23 Fleet Program Manager
- 2.24 Disposal
- 2.25 Funding Document

- 2.26 Zone
- 3. Hull Area Preparation
  - 3.1 Blanking
  - 3.2 Water line markings
  - 3.3 Drydocking
    - 3.3.1 Underwater Surfaces
    - 3.3.2 Sea Chests
    - 3.3.3 Transducer
  - 3.3.4 Hull Blanks
  - 3.3.5 Stern Tube
  - 3.3.6 Range Anchor Chain
- 4. Topside Preparation
  - 4.1 Deck Cleaning
  - 4.2 Booms/Cranes
  - 4.3 Sounding Pipes and Deck Plugs
  - 4.4 Vessel Security
  - 4.5 Mooring Equipment
  - 4.6 Weather Deck Hatch Covers
  - 4.7 Cargo Unit Winches
  - 4.8 Weather-Deck Electrical Wiring
  - 4.9 Fan Openings
  - 4.10 Navigation Equipment
  - 4.11 Fenders/Chafing Strips
  - 4.12 Anchor Windlass Preparation
  - 4.13 Paint
  - 4.14 Lifeboats
  - 4.15 Lifeboat Motors
  - 4.16 Accommodation Ladders
  - 4.17 Mooring Reels
  - 4.18 Overboard Discharge Openings
  - 4.19 Wooden Decks
  - 4.20 Handrails and Ladders
  - 4.21 Fire Fighting Equipment
  - 4.22 Stack Covers
- 5. Interior Preparation
  - 5.1 Stern Gland
  - 5.2 Shaft Lock
  - 5.3 Rudder Lock
  - 5.4 Sea Valves
  - 5.5 Cleaning
  - 5.6 Hazardous Material and Hazardous Waste
    - 5.6.1 Fuel

- 5.6.2 PCBs
- 5.7 Asbestos
- 5.8 Bilges
- 5.9 Floor Plates/Gratings
- 5.10 Extermination
- 5.11 Flooding/Fire/Power Available Alarms
- 5.12 Fixed CO2 System
- 5.13 Dunnage
- 5.14 Water Tanks
- 5.15 Cargo Tanks
- 5.16 Tank Soundings
- 5.17 Interior Hatch Covers
- 5.18 Items to be Stowed
- 5.19 Inventory
- 5.20 Valves
- 5.21 Stowage and Air Diffusion
- 5.22 Draining
- 5.23 Boiler, Main
- 5.24 Boilers, Auxiliary
- 5.25 Diesel Engines, Main and Auxiliary Machinery
- 5.26 Ventilation
- 5.27 Ozone Depleting Substances (Refrigeration Systems)
- 5.28 Motors and Generators
- 5.29 Megger Readings
- 5.30 Chlorinator and Retention Tanks
- 5.31 Elevators/Dumbwaiters
- 5.32 Lamping
- 5.33 Tankers
- 5.34 Berthing Areas

## 6. Preservation

- 6.1 Dehumidification Installation
  - 6.1.1 D/H Equipment
  - 6.1.2 D/H Plan
  - 6.1.3 Deleted
  - 6.1.4 D/H Control
  - 6.1.5 Ducting and Wiring
  - 6.1.6 Exterior Ducting
  - 6.1.7 Power Distribution
  - 6.1.8 Proof of Operation
  - 6.1.9 Sealing
  - 6.1.10 Air Testing
- 6.2 Cathodic Protection
- 6.3 Coating Maintenance

Appendix A: Items to be Stowed

Appendix B

- Description and Diagram of Strong back & J-bolt Securing Device
- Shaft Lock Diagram
- Rudder Lock Diagram

Appendix C Form MA-496 Reimbursable Vessel Acceptance Report

## 1. GENERAL

1.1 PURPOSE. The purpose of this document is to set forth the minimum requirements for deactivation and lay-up and acceptance of a vessel for subsequent placement in a National Defense Reserve Fleet site under custody of the Maritime Administration. The vessel can be received from a government agency under terms set forth in a Memorandum of Agreement (MOA) and funded annually via funding documents (e.g., MIPRs) or other approved funding transfer methods.

1.2 ELIGIBLE VESSEL TYPES. Vessels designated for NDRF layup shall be convertible merchant types or other types determined eligible by the Chief, Division of Sealift Operations.

1.3 PRELIMINARY ACCEPTANCE AND RESTRICTIONS. When a vessel is designated for NDRF layup, the sponsor shall contact the Chief, Division of Sealift Operations (MAR-612) to review acceptance criteria and restrictions concerning maximum draft, height limitations and the availability of moorage. MARAD's acceptance of any vessel will be decided based upon the capability of the designated fleet to properly moor the vessel and safely and securely maintain it for the duration of its layup in the fleet site. As a rule all vessels will have their draft reduced to the minimum practical, in no case exceeding the draft limit for the assigned fleet site. Because published drafts are mean low water for respective fleet sites, acceptance into a fleet site may be decided on a case-by-case basis based upon current conditions and deep berth availabilities. Air draft indicates the maximum clearances (i.e., under bridge structures in route to respective fleets) at mean high water.

<u>Fleet Site</u>	<u>Draft</u>	<u>Air Draft</u>
James River	25 feet	145 feet
Beaumont	28 feet	136 feet
Suisun Bay	26 feet	135 feet

1.4 PRELIMINARY REQUIREMENTS. Upon vessel acceptance MARAD will evaluate the work to be performed as specified herein. For matters not adequately covered by this instruction, MARAD will provide clarification and/or resolution. Sponsors shall coordinate with the MARAD fleet staff during this phase and provide the following:

- Scheduling of a vessel's prospective dry-docking, bottom repair, bottom painting, underwater blanking of sea chests, sea connections and hull scantling readings.
- Scheduling of deactivation/lay-up.
- Date the vessel will be ready for tow to the fleet site (at least seven (7) days advance notice required).

*Upon preliminary acceptance, a mandatory acceptance inspection, certified by form MA-496 Reimbursable Vessel Acceptance Report (Appendix C), is conducted to ensure compliance with all the provisions herein. A copy of the completed MA-496, along with a copy of the vessel's latest drydock report shall be provided to the Fleet Program Manager prior to delivery. While it is the sponsor's responsibility to plan and supervise all work performed in preparation for delivery, copies of any shipyard specifications used shall be made available to MARAD for*

*review prior to final acceptance. MAR-612 will make all final acceptance determinations based upon recommendations from Fleet Program Managers.*

1.5 FINAL ACCEPTANCE. MARAD's acceptance of any vessel into the NDRF will be based on the capability of the assigned fleet to safely and securely maintain the vessel for the duration of the layup, and the condition of the vessel relative to the layup requirements specified herein. Upon MARAD acceptance the sponsor shall provide MARAD with the following:

- Liquid load/tank soundings, identifying tank contents and amounts, including any ballast or water treated with sodium silicate or any other substance.
- Sounding Tube Locations
- Location and type of permanent ballast
- Drawing(s) of hull Blank Locations
- Booklet of General Plans, including hydrostatic curves and tables
- Complete inventory of all Hazardous Materials to be left aboard.
- Asbestos Sampling Survey
- Radiological Report
- PCB Inventory and Sampling Report including a list of all PCBs removed from the vessel in accordance with Section 5.6.2.
- Mercury Survey
- Ozone depleting substances survey
- Sodium Chromate Survey of Tanks
- CHT System Certification of Cleaning and Gas Free Report
- Deratification Survey
- Certification of Declassification (for former military vessels only)
- Certification of Demilitarization (for former military vessels only)
- Copy of ship's paint schedule

1.6 DELIVERY TO THE NDRF FLEET SITE. A vessel accepted for layup shall be delivered by the sponsor or its agent, at the sponsor's expense, to the assigned fleet site. The vessel shall have positive stability, no more than a moderate trim and not more than 0.5 degree list. If possible, permanent hull cathodic anodes should be submerged.

1.7 BERTHING AND LAYUP EXPENSES. Any major layup work that is planned shall be accomplished prior to the vessel entering the fleet site. This normally includes sealing of spaces for weather tightness. Sponsors are responsible for all costs, including overhead, associated with berthing their vessels at NDRF sites. Sponsors may be further responsible for additional costs associated with the vessel's arrival at the fleet site, to include but not be limited to shore power hookup, installation of preservation systems.

1.8 CUSTODY AND PRESERVATION COSTS. Sponsors shall retain accountability for their vessel after delivery and continue to fund all associated custodial and preservation costs. MARAD will provide services, as agreed, on a reimbursable basis. A joint agency Memorandum of Agreement (MOA) shall be executed to provide more specific guidance concerning work to be performed and the applicable reimbursement arrangements. Funding

shall be provided via "MIPRs" or other approved methods to cover costs identified in annual estimates.

1.9 PRE-ARRIVAL INSPECTION. The Fleet Program Manager will schedule a pre-arrival inspection prior to vessel arrival at the fleet site. As this inspection serves to identify and document any critical discrepancies, it must be coordinated to allow sufficient time to properly address any deficiency prior to delivery. The Fleet Program Manager will coordinate this inspection to ensure that a representative from the sponsor's organization is in attendance. Depending on conditions found, subsequent re-inspections may be required.

1.10 ARRIVAL INSPECTION. An arrival inspection will take place upon the vessel's arrival at the fleet site. This inspection serves to identify and document vessel condition relative to cleanliness, orderliness, sanitation, security, status of hazardous materials, water tight integrity, and safety, and will be scheduled to ensure that a representative from the sponsor's organization is in attendance.

1.11 STRIPPING AT FLEET SITES. Fleet site stripping of installed machinery, equipment and components not essential for safe lay-up (anchor windlass, bower anchors and chains must remain) from a vessel designated for disposal is permissible prior to title transfer provided such actions do not compromise the vessel's watertight integrity, towing seaworthiness, the safety of workers, or other conditions or requirements specified herein. Any exposure of hazardous material or friable asbestos resulting from these activities must be addressed as outlined in applicable sections herein. Stripping activities will be restricted based upon the ability of MARAD to provide support and maintain safety. All associated costs shall be reimbursed by the sponsor. If certain items aboard a vessel cannot be stripped prior to title transfer, those items shall be tagged and identified to MARAD for later removal.

1.12 TITLE TRANSFER. Titles to vessels determined acceptable by MARAD may be transferred to MARAD as a means of conveyance or disposal. (Note: Vessels of less than 1500 gross tons are disposed by GSA as per 40 U.S. Code Section 484.) The following documentation (or equivalent) is required for title transfer: General Arrangement Plan(s), Sounding Tube Location Drawing(s), Capacity Plan(s), Docking Plan(s), Hydrostatic Table(s), Trim and Stability Booklet(s), and the combination(s) to any safe(s) remaining on board. Vessels less than 2000 gross tons will require gross tonnage certification.

1.13 TYPICAL ORDER OF EVENTS. The following order of events is typical for laying up a reimbursable custody vessel in a MARAD Reserve Fleet site, and shall be followed under normal circumstances. Sponsors with multiple reimbursable custody vessels shall consolidate their requirements.

1. The sponsor notifies the Chief, Division of Sealift Operations (MAR-612) of a need to lay-up a vessel in a MARAD Reserve Fleet, specifying a preferred entry date, the length of time for storage (if known), and the dimensions of the vessel. This notification normally takes the form of an annual forecast of corresponding requirements (stipulated in an MOA between MARAD and the sponsor), but may come anytime as a result of the emergent requirements.

2. MAR-612 informs the Fleet Program Manager of the sponsor's requirements and requests a corresponding cost estimate.
3. The Fleet Program Manager submits a cost estimate for arrival and first (fiscal) year custody services to MAR-612.
4. MAR-612 confirms the capability of the respective fleet site to maintain the vessel and provides the sponsor with a first (fiscal) year cost estimate, along with a copy of the MA-496 instructions detailing requirements and responsibilities.
5. The sponsor forwards to the respective Fleet Program Manager a "custody package" (consisting of the specific documentation outlined in section 1.5 above), a "fact sheet" describing the incoming vessel's *particulars* (i.e., standard dimensions and critical background information).
6. A salary code is assigned to the vessel for the tracking of applicable labor charges within the MARAD accounting system.
7. After receiving the "custody package", the fleet schedules a *pre-arrival* inspection of the vessel with the sponsor's concurrence on a mutually agreeable date.
8. The fleet conducts a joint pre-arrival inspection with the sponsor, using form MA-496 as a guide, and confirms the accuracy of the previously submitted documentation.
9. The fleet forwards the pre-arrival inspection report to the sponsor within seven (7) working days of completion. The report documents the inspection and identifies any discrepancies that would preclude vessel acceptance.
10. The sponsor takes any necessary corrective actions, notifying the fleet when completed. Based on the nature of the discrepancies, the Fleet Program Manager determines whether an additional inspection is necessary. If warranted a follow-up inspection is scheduled and conducted. The sponsor submits a completed form MA-496 to the Fleet Program Manager.
11. If the sponsor has requested a waiver from certain requirements, MARAD will decide whether or not to grant the waiver and will promptly notify the sponsor.
12. Vessel arrival is scheduled and jointly coordinated. The fleet issues a Ship Delivery Certificate to the sponsor and forwards a copy to MAR-612.
13. The fleet promptly conducts a vessel Arrival Inspection and forwards a Ship Condition Report (Form MA-279) to MAR-612 and the sponsor within three (3) working days. This report will document vessel material condition at the time of arrival.

2. **DEFINITIONS AND ABBREVIATIONS.**



- 2.1 RETENTION. The classification of a vessel kept in a state of preservation for the purpose of future mobilization. The degree of preservation is the sponsor's option and may vary from a minimum of simple periodic inspections to a maximum of dehumidification monitoring, cathodic protection, a painting schedule (environmental conditions permitting), and minor maintenance.
- 2.2 NON-RETENTION. The classification of a vessel intended for eventual disposal, not requiring preservation. Such vessels will be provided the minimal degree of care to ensure a safe mooring condition.
- 2.3 STOWAGE. The relocation of loose items aboard a vessel to a designated secure location.
- 2.4 DEACTIVATION. The general maintenance and preservation of a vessel following a period of activation to ensure water tight integrity, cleanliness and orderliness, and overall suitability for layup.
- 2.5 NDRF. National Defense Reserve Fleet
- 2.6 D/H. Dehumidification Preservation
- 2.7 C/P. Cathodic Protection Preservation
- 2.8 MARAD. Maritime Administration
- 2.9 LAYUP REQUIREMENTS. Minimal preparations required for layup.
- 2.10 NDRF DESIRABLE. Any vessel that MARAD determines provides value to the NDRF. MARAD may choose to apply more thorough preservation to such vessels.
- 2.11 DEFERRED ITEMS. Work MARAD determines can be put off, or deferred, without unacceptably affecting the overall capabilities of the vessel.
- 2.12 SPONSOR. Any accountable organization entering into an agreement with MARAD concerning the reimbursable custody of their vessel(s) in the NDRF.
- 2.13 SHORT TERM. Duration lasting less than one year.
- 2.14 LONG TERM. Duration lasting one year or longer.
- 2.15 PRESERVATION. Various applications to include D/H and C/P for maintaining a vessel in reasonably the same condition as when it arrived at the fleet.
- 2.16 MEMORANDUM OF AGREEMENT. An agreement, normally in the form of a signed document, between two or more agencies, setting forth the authority and responsibilities of each

under certain circumstances.

2.17 HAZARDOUS MATERIAL. *Useable* liquid, solid or gaseous material which, if released or spilled, may pose a hazard to human health or the environment due to quantity, concentration, physical, chemical or infectious characteristics.

2.18 HAZARDOUS WASTE. *Unusable* liquid, solid or gaseous material which, if improperly managed, may pose a hazard to human health or the environment due to quantity, concentration, physical, chemical or infectious characteristics.

2.19 STRIPPING. The removal of equipment, parts, fixtures or any other items of value from a vessel in preparation for disposal or scrapping. Fleet personnel will generally not be utilized as a labor source to strip vessels except on a reimbursable basis. Utilization of fleet personnel for stripping will be at the discretion of the Fleet Program Manager and dependent upon fleet operational priorities. Sponsors may make arrangements with MARAD to set up or continue their own stripping programs and activities aboard their vessels in MARAD custody.

2.20 CANNIBALIZATION. The dismantling and/or removal of equipment, parts, fixtures, or any other items from a vessel in order to support another vessel or operation. Fleet personnel will generally not be utilized as a labor source to facilitate vessel cannibalization except on a reimbursable basis. Utilization of fleet personnel for cannibalization will be at the discretion of the Fleet Program Manager and dependent upon fleet operational priorities. Sponsors may make arrangements with MARAD to set up or continue their own cannibalization programs and activities aboard their vessels in MARAD custody.

2.21 CHIEF, DIVISION OF SEALIFT OPERATIONS (MAR-612). Individual responsible for the development and implementation of Reserve Fleet policy and programs. Resides at MARAD Headquarters and reports directly to the Director, Office of Ship Operations.

2.22 SHIP OPERATIONS and MAINTENANCE OFFICER (SOMO). Individual responsible for effecting all MARAD policy and programs within a specific geographic region.

2.23 FLEET PROGRAM MANAGER. Individual responsible for carrying out Division of Sealift Operations programs and policies within a specific fleet site.

2.24 DISPOSAL. The relinquishment of vessel ownership through title transfer or other means. The sponsor has the option to dispose of non-combatant (merchant type) vessels 1500 gross tons or more via title transfer to MARAD. MARAD is the federal disposal agency for non-combatant vessels 1500 gross tons or more; GSA is the federal disposal agency for vessels less than 1500 gross tons.

2.25 FUNDING DOCUMENT. A document obligating funds from a federal agency/sponsor for purposes generally specified in a corresponding MOA.

2.26 ZONE. A compartment or series of compartments segregating areas of the vessel, generally structurally formed and requiring a separate access.

### 3. HULL AREA PREPARATION.

3.01 GENERAL. Vessels will not be accepted into fleets unless they have been dry-docked within two (2) years of fleet entry, unless Marad agrees that the hull is in an acceptable condition for the planned duration in fleet custody. With the exception of in-class operational vessels or vessels originating from within the same biogeographical waters, vessel hulls shall be cleaned of growth prior to fleet entry.

3.1 BLANKING. All vessels shall have external blanks installed. Detailed blanking requirements are found in section 3.3.4 below. Upon waiver request, Marad may allow internal blanks for short term durations only.

3.2 WATERLINE MARKINGS. All vessels shall have waterline markings painted on the hull: Four (4) inch wide stripes along the waterline extending horizontally forty-eight (48) inches toward midships from the bow and stern on both sides of the vessel. Markings shall be of two coats of highly visible (e.g., reflective white or international orange) paint and applied to perform well over a long period of time. A second marking stripe shall be applied approximately four feet above the waterline. The trailing edge of the rudder shall also have markings applied.

3.3 DRYDOCKING. Vessels scheduled for drydocking prior to layup have additional requirements per section 3.3 herein as follows:

3.3.1 UNDERWATER SURFACES. Underwater surfaces shall be prepared up to the wind and water line by removing all foreign substances including loose paint, rust, and scale. Underwater body, rudder, and appendages shall be painted from the keel to two (2) feet above the waterline with three (3) coats of high solids surface tolerant epoxy compatible with the existing underwater coating system at least 15.0 mils dft. Alternate coating systems may be approved by MARAD. All coating systems shall apply to all applicable Federal, State and Local regulations that may be in force at the time.

3.3.2 SEA CHESTS. Unless hull openings are externally blanked, sea chest strainer plates shall be removed, cleaned, painted, and tagged and stowed in a protected area aboard the vessel, and sea chest interior surfaces coated with a high solids surface tolerant epoxy.

3.3.3 TRANSDUCER. Transducer cover plates, if fitted, shall be installed. Large Navy type transducers shall be structurally protected or removed.

3.3.4 HULL BLANKS. Exterior blanking of at least one-half (½) inch thickness shall be installed on all openings below the waterline. Blanks shall be internally stiffened, box type or bolt type closures except within the area extending from two (2) feet below to four (4) feet above the quiescent waterline, where only flush type blanks shall be used. Blanks shall be air tested to 2.5 psi, ensuring the pipe plug seals are maintained. A drawing or outline identifying all blanking, location and type, shall be provided to MARAD upon completion.

3.3.5 STERN TUBE. Stern and rudder glands shall be repacked. Stern tube and strut bearing

boots may be installed at the sponsor's discretion. The outer seal on oil lubricated stern tube bearings shall be caulked or otherwise sealed.

3.3.6 RANGE ANCHOR CHAIN. The anchor chains shall be ranged, washed, abrasive grit blasted to SSPC-SP-7 specifications and properly marked. Gauging and the replacement of deteriorated parts or sections may be required. Chains, chain locker, sump and hand pump system shall be drained and thoroughly cleaned and preserved prior to re-stowing chain. Eductors shall be operable.

#### 4. TOPSIDE PREPARATION.

4.01 GENERAL. Topside surfaces shall be coated and substantially free of loose or exfoliating paint, rust and scale, or encapsulated in a manner that will last at least 5 years. All topside openings and penetrations shall be sealed and/or proven watertight by hose test.

4.1 DECK CLEANING. Loose and/or unnecessary topside material or equipment shall be removed and/or stowed. Decks shall be thoroughly cleaned, free of oil and grease residue, dirt and other debris with drains clean and clear.

4.2 BOOMS/CRANES. Booms/cranes shall be properly secured in their cradles, with vang, blocks, and other loose running gear tightly secured in suitable locations. Heavy lift booms shall be properly secured in their normal position (usually vertical), with all loose gear tightly secured in suitable locations. All equipment shall be cleaned and drained of any hydraulic fluids.

4.3 SOUNDING PIPES AND DECK PLUGS. All sounding pipes shall be proven clear by observing maximum soundings. Deck fittings and plugs shall be serviceable. Sounding pipes and plugs shall have legible identification. Plugs and tags shall be renewed as required. Quick closing sounding tube valves shall be functional. Threads of the deck fittings and plugs shall be adequately greased. A drawing of tank sounding pipe locations shall be provided.

4.4 VESSEL SECURITY. All skylights, doors, hatches, portholes, and windows shall be secured. Emergency exits shall be provided in accordance with OSHA requirements. Non-emergency access shall be limited to two (2) exterior main deck doors per zone, painted bright yellow, each fitted with hasp and bale or other suitable locking device. Common keyed locks shall be applied, with keys turned over to MARAD. All other exterior doors and openings shall be secured in such a way as to allow keyless exit from inside and no entry from the outside. Appendix B provides details on an acceptable method.

4.5 MOORING EQUIPMENT. All mooring bits, fairleads, capstans and windlasses shall be operable and clear of any obstructions. Hydraulically powered equipment shall be leak free. Necessary mooring wires or MARAD approved high-performance synthetic line will be provided by the sponsor. All anchors shall be in place with a full complement of anchor chain, the bitter end of which shall be properly secured in the chain locker. Anchors shall be ready for letting go (e.g., riding pawls not down and spill pipes uncovered and cement free) upon arrival at the fleet site without the need to energize the anchor windlass. MARAD will provide electric power as required to support electric windlasses, which shall be serviceable, unless the sponsor

is otherwise advised. Steam windlasses shall be prepared as follows: A section of steam line shall be removed in way of the steam valve and a flange installed fitted with a 1 1/2" pipe connection quick disconnect fitting. The exhaust valve shall also be removed and those sections of the steam and exhaust lines leading aft shall be blanked off. The removed sections of steam lines and exhaust valve shall be secured by wire to the windlass.

4.6 WEATHER-DECK HATCH COVERS. All weatherdeck hatch covers shall be made watertight, seals replaced if necessary. Folding type hatch covers shall be closed and dogged. All hatch tarps shall be in good condition and securely tied down. Weather tightness shall be proven by hose test.

4.7 CARGO UNIT WINCHES. Shall be properly cleaned, preserved, and weather proofed. All cargo gear shall be leak free, drained or repaired to prevent spills. If cargo is to be removed for stowage it shall be drained of all fluids and lubricants.

4.8 WEATHER-DECK ELECTRICAL WIRING. Wherever electrically operated equipment is to be removed from a weather-deck, its wiring shall never be cut but shall be disconnected from the equipment and pulled back into the ship. The opening thus created will be made watertight by blanking as previously specified. The exposed connections shall be dead and the corresponding switches shall be tagged out.

4.9 FAN OPENINGS. All weather-deck fan openings shall be made watertight by blanking. All ventilator cowls shall be removed and metal blanks installed.

4.10 NAVIGATION EQUIPMENT. Gyro repeaters, searchlights, speakerphones, signaling devices, insulators, and nonexpendable light fixtures, etc., shall be removed, tagged and stowed inside a secured storeroom.

4.11 FENDERS/CHAFING STRIPS. Ships fitted with fenders, rubbing or chafing strips constructed of wood shall have such material removed. If the material is considered usable by the sponsor it may be stowed below on dunnage in areas where it will not interfere with personnel approaching and examining the ships interior while the ship is under D/H. Fenders of wood construction will be provided by each respective fleet on a reimbursable basis as required for nested mooring.

4.12 ANCHOR WINDLASS PREPARATION. Anchor chains and chain locker shall be in a highly clean condition. If necessary, the chain shall be backed out to the bitter end, chain locker thoroughly cleaned chain high pressure water blasted, and chain locker pumped dry. If it is necessary for a ship to make a sea passage prior to arrival at the reserve fleet site, watertight covers shall be placed over the Spurling (spill) pipes. However, upon arrival at the fleet site the anchors shall be ready for letting go without the need to energize the windlass.

4.13 PAINT. The hull, deck and superstructure coatings should be intact and of such a quality that no further exterior preservation will be required for at least the ship's first two years in the fleet site. This determination will be made through a joint inspection by sponsor and MARAD representatives.

4.14 LIFEBOATS. Lifeboats shall be stripped of all equipment; fuel tanks drained and made gas free. Dispose of all dated equipment, provisions and pyrotechnics. The lifeboat should, if possible, be stowed in a designated D/H area on chocks in an upright position 18 inches off the deck and at least 2 feet from the skin of the ship and secured. If not stowed, they shall be secured on deck or in the falls. If it is desirable to have lifeboat falls periodically exercised, a metal H-beam or concrete blocks of sufficient weight to pull out the falls shall replace the boat.

4.15 LIFEBOAT MOTORS. Lifeboat motors shall be completely drained of water, oil and fuel. Salt water cooling systems shall be flushed with fresh water. Remove spark plugs or injectors if diesel driven, from motor and inject one-half pint of an approved preservation oil in each cylinder. Replace spark plugs or injectors after cranking engine over two complete revolutions. Clean and gas-free fuel tanks.

4.16 ACCOMMODATION LADDERS. Accommodation ladders and winches shall be stowed in its proper place, inspected, and repaired as necessary to ensure good operation. Grease all hinges and cover the winch motor with a tarpaulin. It may be needed to allow access to the ship.

4.17 MOORING REELS. Wire and fiber rope mooring reels shall be removed and stowed in a designated area.

4.18 OVERBOARD DISCHARGE OPENINGS. Install blanks on all overboard discharge openings above the floatation line (do not blank deck scuppers).

4.19 WOODEN DECKS. Wooden decking shall be removed for vessels to be in long term lay-up. Any broken paint coatings shall be repaired. Any holes shall be made airtight. All wooden deck gratings shall be removed, tagged, and stowed.

4.20 HANDRAILS AND LADDERS. Defective handrails and ladders are to be repaired, replaced, or removed. Safety chains/wire and stanchions shall be installed when ladders are removed and/or a personnel hazard would otherwise be created.

4.21 FIRE FIGHTING EQUIPMENT. Remove all fire hoses, nozzles and self-cleaning strainers from topside and stowed below deck. Such equipment located at fire stations in the interior spaces of the vessel may remain in place. Portable fire extinguishers of the soda acid type shall be discarded and all other types shall be stowed in a sealed storeroom.

4.22 STACK COVERS. A metal stack cover shall be secured in place and airtight.

## 5. INTERIOR PREPARATION.

5.1 STERN GLAND. Stern glands shall be made watertight. Conventional packing glands shall have sufficient packing for future take-up. All vessels fitted with oil lubricated stern bearings shall have the sealing systems serviced and all reservoirs and tanks filled. Sponsor shall ensure sealing systems are leak free.

5.2 SHAFT LOCK. The shaft-locking device shall be installed in accordance with specifications set forth in Appendix B or per a recognized marine classification society. Each shaft-locking device shall be designed and fabricated based upon an engineering analysis establishing optimum bolt sizes and acceptable tolerances for securing the shaft. Shaft locks shall be designed and fabricated so as to accommodate ready towing, thus eliminating the need for on board welding. Shaft locks shall be painted with 1 coat of bright yellow paint.

5.3 RUDDER LOCK. The rudder shall be physically secured by rudder lock in the midships position to the satisfaction of the MARAD representative. The steering motors shall be secured and all hydraulic valves closed. Appendix B shows an example of a commonly used rudder lock. It shall be designed and fabricated so as to facilitate ready securing for towing without the need for additional welding. Rudder locks shall be painted with 1 coat of bright yellow paint.

5.4 SEA VALVES. All sea valves shall be secured with valve wheels chained and locked to the valve body. Keys shall be turned over to MARAD. All electric, hydraulic, and pneumatic-operated valves shall be disabled at the controller.

5.5 CLEANING. All spaces, including engine and boiler rooms, shall be thoroughly cleaned to remove all dirt, loose paint and scale, oil, grease, water, and other foreign materials. All trash and debris shall be removed from the vessel. Staterooms shall be left clean, dry and secured by locking. All toilets shall be clean covered by plywood banded to the fixture, or other method, to prevent fouling. A full set of keys shall be provided to MARAD. All drawers and lockers in berthing areas shall be emptied, cleaned and secured. All rooms, compartments and passageways shall be swept clean, damp mopped and left dust free. All foodstuff and consumable liquids and material shall be removed from the vessel. Refrigerators shall be emptied and cleaned. All weapons (including small arms) and ammunition shall be removed. Excepting supporting fire prevention systems (i.e., CO<sub>2</sub>), all gas cylinders (e.g., freon, oxygen, hydrogen, acetylene, etc.) shall be removed. All recreational reading material, leased equipment, and personal effects shall be removed. All hazardous waste, medicines, and medical wastes shall be removed. *All documentation shall be secured in file cabinets or the ship's safe for permanent storage.*

5.6 HAZARDOUS MATERIAL AND HAZARDOUS WASTE. Before a vessel enters the fleet site, the sponsor shall demonstrate during the prearrival inspection that the vessel is environmentally safe and free of hazardous waste. While it is preferred that all bulk hazardous material be removed, MARAD may permit small amounts to remain on board. Any hazardous material deemed to be part of the vessel's structure or an integral part of a shipboard system may remain on board. Any remaining hazardous material shall be recorded in a detailed inventory accompanied by Material Safety Data Sheets (MSDS's) and be safely stored and protected by secondary containment systems. A separate report shall be provided summarizing the status and amount of PCBs aboard the vessel. The sponsor will reimburse any and all costs incurred as a result of handling hazardous material.

5.6.1 FUEL. All fuel shall be removed and tanks pumped dry with the exception of those in support of the emergency diesel generator. Any fuel remaining shall be treated with an

appropriate biocide. Where fuel removal requirements are waived (typically only in the case of in-class operational vessels), fuels shall be consolidated to internal tanks not sharing hull walls.

5.6.2 PCBs. Prior to acceptance, the sponsor shall provide MARAD with a polychlorinated biphenyl (PCB) inventory, which summarizes the status, locations, and amounts of PCBs aboard the vessel, including, but not limited to, cable, insulation, rubber gaskets, felt gaskets, thermal insulation material, transformers, capacitors, heat transfer dielectric fluid, electronic equipment containing internal capacitors and/or transformers, voltage regulators, switches, reclosers, bushings, electromagnets, adhesives, tapes, hydraulic oil, cork hull anti sweat insulation, caulking, rubber isolation mounts, foundation mounts, pipe hangers, and light ballasts. PCB contaminated liquids and or materials shall be removed if possible. If not removed, all remaining items containing PCBs shall be identified and labeled in accordance with Federal regulations (Title 40 USC). An inventory of PCB contaminated items remaining aboard the vessel shall be provided to the Fleet Program Manager. All hydraulic fluid systems shall be tested for PCBs. With the exception of hydraulic systems critical to the maintenance or safe mooring of the vessel all hydraulic systems containing PCBs must be drained of all fluids. The Fleet Program Manager shall be provided a listing of all hydraulic systems retaining hydraulic fluid along with Material Safety Data Sheets (MSDS) and results of laboratory analyses (with chain of custody forms) documenting the composition of the fluid(s) shall be provided. *Any PCB-free hydraulic fluid remaining aboard shall be certified in writing as being free of PCBs with the corresponding laboratory analysis provided, and the equipment marked as such.*

5.7 ASBESTOS. All damaged or deteriorated asbestos shall be abated by removal or repair so as to prevent the spread of airborne asbestos fibers. The sponsor shall conduct air sampling and laboratory analysis for concentrations of airborne asbestos fibers in all areas suspected to contain asbestos or asbestos residues. Sampling shall be conducted by or under the technical supervision of a certified industrial hygienist. A certified/signed copy of the laboratory analysis report shall be furnished to the Fleet Program Manager before the vessel will be permitted entry into the reserve fleet. The sponsor shall further ensure that signs are posted on all entrances leading to areas containing asbestos in compliance with OSHA regulations contained in 29 CFR 1915.1001 sections (K)(6) through (K)(8).

5.8 BILGES. Bilges and tank tops shall be pumped dry and made free of oil, water, and contaminants.

5.9 FLOOR PLATES/GRATINGS. Floor plates, gratings and supports shall be secured in place. Missing plates and handrails shall be replaced.

5.10 EXTERMINATION. A qualified exterminator shall rid the vessel of both rodents and objectionable insects prior to delivery to the MARAD reserve fleet site and a written confirmation shall be provided.

5.11 FLOODING/FIRE/POWER AVAILABLE ALARMS. One complete electrical flooding and fire alarm system shall be installed aboard the vessel. MARAD normally utilizes a 115 volt AC system on powered rows; alternatively, battery or solar power systems (12 or 24 volt DC) are used in un-powered rows. The Fleet Program Manager shall be consulted prior to any



flooding or fire alarm system installation. The flooding alarm system shall be set in drain wells on tank tops (lowest point) in the engine room, shaft alley, and other places designated by MARAD. On ships with DH installed, a smoke detector or heat sensitive unit (fire wire) activated at 150 degrees Fahrenheit shall be located above each DH machine installed with the necessary watertight connection boxes, fused safety switches and marine type lighting fixtures. An alarm panel shall be located high on the stern of the vessel and shall consist of the following: (1) a red strobe light and a continuous sounding siren for activation by the fire sensors; (2) a yellow strobe light and pulsating siren for activation by the flooding sensors; and (3) a continuous white/blue power alarm system power available light. If the sponsor is unable to provide an adequate system, MARAD may provide it on a reimbursable basis. The systems will be tested and repaired or replaced, if necessary.

5.12 FIXED CO2 SYSTEM. All fixed and semi-portable CO2 system(s) shall be disarmed and all CO2 bottles disconnected from discharge piping and capped. Low-pressure bulk tank CO2 systems shall be emptied upon deactivation. All other types of fixed firefighting systems shall be disabled. Halon systems shall be treated as CO2 systems.

5.13 DUNNAGE. All wooden and temporary dunnage shall be removed from the vessel. Stainless steel and dunnage of a more permanent nature shall be neatly stacked in each cargo space.

5.14 WATER TANKS. All potable and fresh water tanks shall be pumped dry unless otherwise directed.

All liquid ballast, not essential for trim or stability, shall be removed. Where ballast is left aboard, watertight blanking shall be installed. All water ballast aboard shall be fresh dock water (non-river). Where tanks are not emptied, they shall be pressed to limit free air space. Questions regarding amount and retention of water ballast required for stability purposes shall be referred to the Fleet Program Manager.

5.15 CARGO TANKS. Cargo tanks shall be thoroughly stripped, cleaned and gas freed before arrival at the fleet site. A gas free certificate shall be properly posted with copy provided to the Fleet Program Manager. Tankers offered for lay-up shall have all cargo tanks, pump rooms and pipelines gas freed with a gas free certificate properly posted.

5.16 TANK SOUNDINGS. Current soundings of all tanks, including oil, fuel, and water left on board shall be provided, along with documentation listing the specific contents (complete description and amount) of each tank. Empty tanks shall be identified. Vessel drawings showing location, frame numbers and proper identification for all tanks, sounding tubes and tank sounding tables shall be provided. All missing drawings shall be identified.

5.17 INTERIOR HATCH COVERS. Interior hatch covers shall be closed and secured, complete and in good condition. The Fleet Program Manager shall be consulted in all cases concerning unguarded hatches or openings, which may be allowed on case by case bases.

5.18 ITEMS TO BE STOWED. All loose and/or easily removed items left aboard shall be

stowed below decks or in secure lockers. These items include, but are not limited to, the items listed in Appendix A. Storerooms for pilferable items shall be secured by welding, or alternatively secured at the discretion of the Fleet Program Manager. Two screened openings of approximately 8" X 10" should be provided in welded storerooms to permit flow and circulation of dry air, one opening close to the deck and the other close to the overhead. Large, installed equipment, such radar scanners and engine order telegraphs, may be left in place. The sponsor shall ensure in all cases that easily damaged components are not exposed to the weather. The sponsor shall record an inventory of all such removed and stowed items, permitting MARAD access to the respective locations for purposes of verification prior to securing.

5.19 INVENTORY. An inventory of all non-consumable items left aboard shall be conducted by the sponsor. Item name, description, quantity, condition and location shall be documented. One copy of this inventory shall be placed in the ship's safe or a lockable box in the Ship's or Master's Office, and one copy provided to the Fleet Program Manager. Inventory sheets for each separate location shall also be placed inside storerooms and/or locations, affixed in a conspicuous place. Inventory verification activities shall be coordinated with the Fleet Program Manager.

5.20 VALVES. Settling tank valves and all valves effecting seaworthiness shall be closed, chained and locked to prevent opening, with keys provided to MARAD. All valves shall be surveyed for leaks. Any leaking valves shall be repaired, replaced, or blanked at the flange. The sponsor shall take up on packing glands or repack valves as required, leaving valves and reach rods in good working order.

5.21 STOWAGE AND AIR DIFFUSION. All gear shall be stored in a shipshape manner allowing dry air to reach all items placed under D/H while maintaining easy and safe access to observe D/H effectiveness throughout the ship. For ships that still have hatch boards, all 'tween deck hatch beams shall be fitted in place, with 'tween deck hatch covers fitted over hatches leaving a 3 inch air space between each hatch board. Secure all hatch boards with an athwart ship batten nailed in place. All hydraulic 'tween deck hatch covers shall be closed. Sealed compartments shall be provided with screened openings to allow the diffusion of dry air.

5.22 DRAINING. All systems, bilges and voids shall be completely drained of water and dried. All salt water lines throughout the ship shall be flushed with fresh water and dried. All tanks except lube oil and fuel oil tanks are to be emptied and cleaned. All sewage disposal systems and tanks are to be chemically cleaned, neutralized and dried. Reinstall covers in an ajar position. Package all used securing items (nuts, gaskets, etc.) and wire adjacent to opening. Completely remove all water, sludge, and debris. Manhole plates located above the line of floatation, for tanks that are to be placed under D/H, shall be left open and covered with expanded metal screens capable of supporting at least 225 lbs. at the opening center. Horizontal openings are also to be covered with expanded metal screens. No silica gel is to be placed in emptied tanks (or used elsewhere on ships transferred to MARAD). Manhole covers for those remaining open shall be secured adjacent to the openings together with unused securing items. All deck drains and scuppers on vessel weather decks shall be cleaned and proven clear to the satisfaction of the MARAD representative.

5.23 BOILER, MAIN. The sponsor shall submit a main boiler lay-up plan for approval by MARAD.

5.24 BOILERS, AUXILIARY. The sponsor shall submit an auxiliary boiler lay-up plan for approval by MARAD.

5.25 DIESEL ENGINES, MAIN AND AUXILIARY MACHINERY. The sponsor shall submit a diesel engine, main and auxiliary machinery lay-up plan for approval by MARAD.

5.26 VENTILATION. Remove and clean filters, clean fans and related ducting.

5.27 OZONE DEPLETING SUBSTANCES (REFRIGERATION SYSTEMS). The sponsor shall submit a refrigeration systems lay-up plan for approval by MARAD. The sponsor shall wash down all reefer boxes with a solution of sodium bicarbonate. All reefer box doors shall be left ajar and blocked up to take the weight off the hinges. All bottled ozone depleting substances shall be removed from the vessel prior to MARAD acceptance inspection. The sponsor shall provide MARAD with ozone depleting material survey upon completion of the tasks required by this section.

5.28 MOTORS AND GENERATORS. All motors of at least one horsepower and generators shall be cleaned of all dirt, excessive oil and grease. Brushes shall be left in place but with their spring tension released and with the brushes lifted from the surface of the commutators.

5.29 MEGGER READINGS. Insulation resistance readings shall be taken of all generators and motors except those of fractional horsepower. Results of these readings shall be recorded and delivered to the Fleet Program Manager.

5.30 CHLORINATOR AND RETENTION TANKS. Chlorination and retention tanks shall be thoroughly cleaned. Remove and dispose of the charcoal purifier tanks and leave covers off tanks by turning the cover to the bottom and secure it with two studs or bolts.

5.31 ELEVATORS/DUMBWAITERS. Secure elevators and dumbwaiters to meet the American Standard Safety Code for elevators. Pits shall be thoroughly cleaned out. Land counterweights on blocks, lower car to bottom of well. Blocks are to be arranged to allow access beneath the elevator.

5.32 LAMPING. All emergency light fixtures and at least 50% of the other lighting in the following areas shall be lamped and operational: engine room, emergency generator room, boiler room, shaft alley, steering gear room, cargo spaces used for storage, and living spaces including the bridge. Use of long life impact resistant bulbs is recommended.

5.33 TANKERS. The dehumidification of cargo tanks and/or cargo pump rooms is generally encouraged and may be accomplished at the discretion of the sponsor.

5.34 BERTHING AREAS. Broken door locks on living space doors, lockers and washrooms shall be repaired or replaced. Two full sets of keys shall be provided to MARAD. All sanitary

traps, toilet bowls, sinks and wash basins shall be cleaned and dried out. If no trap drain plug is provided, then the trap shall be removed. All head and washroom doors shall be locked after inspection of the vessel prior to departure for the fleet. This can be accomplished during the draining of the vessel.

## 6. PRESERVATION.

6.1 DEHUMIDIFICATION INSTALLATION. The sponsor shall submit a DH lay-up plan for approval by MARAD. D/H systems may either be installed prior to delivery of the vessel or installed by the fleet after arrival on a reimbursable basis. If installed by the fleet, it is the sponsor's responsibility to ensure the installation meets their requirements.

6.1.1 D/H EQUIPMENT. The D/H system including all equipment and components are typically supplied by the sponsor, but if available may be provided by MARAD. All system components are to be installed aboard ship in locations in consultation with MARAD. The components provided by the sponsor shall be new and of the type and size specified in the D/H plan, and shall include a two year supply of spare parts and a complete set of operating and maintenance manuals. The responsibility for any additional spares for sponsor-supplied equipment lies with the sponsor.

6.1.2 D/H PLAN. The sponsor shall submit a DH lay-up plan for approval by MARAD. Drawings of the D/H system which clearly show the arrangement, directional flow of air, location of humidistat, disconnect switches, power supply circuit, and all other components of the system shall be furnished to the Fleet Program Manager upon vessel delivery.

### 6.1.3 RESERVED

6.1.4 D/H CONTROL. A D/H control system shall be installed that will continuously and automatically control the relative humidity (RH) at a preset level within a dehumidified zone, and indicate whether the humidity factor, (high or low), is being maintained at a prescribed level for the zone controlled by the humidistat. This system must sense and control the RH from all stations within each zone. An electrical box painted bright yellow and fitted with isolation switches for each humidistat (station) shall be located near the D/H machine they are controlling. The switches shall be labeled to indicate the humidistat being controlled. The humidistats, themselves, shall also be labeled.

6.1.5 DUCTING AND WIRING. All wiring (aluminum wire will not be acceptable), ducting, piping, etc., used in the installation of the D/H system shall be secured in an orderly manner, and shall not obstruct free passage throughout the ship. Ducting shall be flame retardant (UL94VTM-0) two-ply Polyester-Neoprene coated, resistant to ozone, UV rays, and mildew, impervious to leakage from most oils, water, chemicals, and grease, within temperature range minus 40 degrees F to 250 degrees F.

6.1.6 EXTERIOR DUCTING. Where exposed to the weather, piping used to tie into the D/H system shall be rigid type and corrosion resistant such as PVC. Proper support brackets shall be installed.

6.1.7 POWER DISTRIBUTION. The following are guidelines for installing an externally mounted electrical distribution system to operate preservation systems separate from the ships circuitry and for the energizing of the ship's main switchboard remotely. The sponsor should meet with the MARAD representative to determine preservation system requirements on a case by case basis. Shore power service at the fleet sites are 3-phase, 440 volt ac. Where single phase is needed to service a component of the D/H system the necessary equipment and materials are to be supplied by the vessels sponsor. Each ship shall be equipped with a 200 amp non-fused disconnect for a main switch, a 30 amp fused disconnect for each cathodic rectifier, one 30 amp fused disconnect for each 440 volt ac. D/H machine at the main disconnect box, a 30 amp fused disconnect for transformer feed, a 7.5 KVA transformer with a 220/110 breaker panel minimum of 6 spaces with a rain tight 110 receptacle, and a 30 amp non-fused disconnect located at the machine. A 100 amp fused disconnect shall also be provided for ship lights. Aluminum wire will not be accepted.

6.1.8 PROOF OF OPERATION. Once the system is installed the proper operation of each component shall be tested to the satisfaction of the MARAD representative. This shall be accomplished by running the D/H machine for a period not less than one hour. The air flow supplied by the D/H machine shall be satisfactory at each outlet.

6.1.9 SEALING. All exterior openings to the atmosphere, including escape pipes, vents, main stack openings, etc., shall be blanked and airtight. Particular attention should be given to the access doors to the vessel. All doors to be used for access during lay-up period shall have proper alignment, dogs freed, adjusted, and chalk tested to ensure proper sealing. The stowage location of equipment removals shall be indicated on a tag affixed to the removal location and listed on the stowage inventory. All watertight openings such as doors, port lights, and vent covers shall be made airtight without the use of soft sealants, by renewing the gaskets, cleaning or renewing knife edges and adjusting dogs where necessary. All bulkhead, overhead, or deck leaks shall be sealed. Any standing water throughout the ship shall be removed. Where soft sealants are necessary a butyl rubber type caulking or silicon type compound shall be used. The use of polyurethane foam for soft seal is not acceptable.

6.1.10 AIR TESTING. At the conclusion of all sealing operations an air test will be conducted to prove airtight integrity. The test will be accomplished by using one 500 CFM fan, or other type of air mover of similar capacity sealed into the D/H boundary. Air within the zone shall be steadily exhausted to the outside atmosphere. The resulting pressure differential between the outside and inside atmospheres created shall be measured with a manometer or other suitable air pressure gauge. Upon obtaining a pressure difference equal to three (3) inches of water, the air mover will be secured and the opening blanked off. The pressure differential shall not drop lower than a reading of one inch of water during a waiting period of ten minutes.

During the initial period of custody the runtime will be monitored to determine sealing integrity. Should machines be found to run more than 40% of the time, which generally indicates a faulty seal, repairs will be performed at the sponsors cost.

6.2 CATHODIC PROTECTION. With the exception of the Beaumont Reserve Fleet, installed internal cathodic protection systems may be used during lay-up. If installed systems are

used, their operability must be proven with all anodes are submerged. Otherwise an external cathodic protection system shall be provided by MARAD on a reimbursable basis.

6.3 COATING MAINTENANCE. Coating maintenance services may be provided by MARAD on a reimbursable basis. Mandatory coating maintenance may be necessitated where coatings are deteriorating.

**APPENDIX A**  
**(ITEMS TO BE STOWED)**

- Antennas, radio
- Barometers \*
- Batteries (new and in a dry state)
- Binnacles \*
- Binoculars \*
- Blocks, portable
- Blueprints
- Books, instruction
- Boxes, storage
- Canvass
- Chronometers \*
- Clinometers \*
- Clocks \*
- Clothing (stewards department)
- Compass, gyro and magnetic \*
- Computers, all types with accessories \*
- Correspondence, vessel
- CO2 Cylinders
- Davits, small gooseneck
- Equipment, galley
- Equipment, medical
- Equipment, office
- Equipment, painting
- Equipment, pantry
- Equipment, safety
- Extinguishers, fire
- Fans, room
- Floodlight, detachable
- Flags \*
- Furnishings, room
- Gangways, brow
- Gratings, weather deck
- Guards, pipe
- Hood, binnacle
- Hose, fire, fresh, steam and air
- Instruments, electrical \*
- Ladders, pilot/SOLAS/Jacob's
- Lashing, chain
- Lifeboats, complete with outfitting gear (food/water not included)
- Lights, embarkation, cargo, and signal
- Line throwing apparatus
- Linen

- Lines, gantlines/heaving lines/tag lines/mooring lines
- Lining, grain and/or ammunition (sheathing)
- Log and bell books
- Machines, washing and drying
- Machines, ice making
- Machines, sounding
- Mattresses
- Medical equipment
- Meters, portable electric \*
- Micrometers \*
- Name boards, detachable
- Navigation instruments (parallel rules, dividers, etc.)
- Navigation equipment (RDF, LORAN, Sat Nav, etc.)
- Pillows
- Radar
- Radio, crew entertainment
- Radio, telephone
- Reels, wire (including wire)
- Refrigerators, domestic type
- Repeaters, gyro compass
- Rope, wire/natural/synthetic
- Scanners, radar
- Screening, weather deck ventilation and ducting
- Searchlights, detachable \*
- Sextants \*
- Spare parts, electrical, mechanical, radio, and navigation equipment
- Table, chart
- Tableware
- Tachometers
- Telephone, sound powered and interior communication
- Television sets \*
- Tools, electrical, hand, and pneumatic
- Transceivers \*
- Typewriters
- Wrenches, special such as propeller, rudder, etc.

NOTE: Items marked as "\*" are considered to be highly pilferable.



## APPENDIX B

An acceptable method for securing exterior doors and openings from the inside (to allow keyless opening from inside and no access from the outside) is to use a strongback and "J" bolt. It can be constructed with a length of 2" X 4" lumber spanning the door opening on the inside of the space. A hole is drilled through the 2" X 4" strongback at a point where a 3/8 inch NC J-bolt can be slipped through the hole and hooked around the door pull. The threaded end of the J-bolt, now protruding through the strongback, is secured against the strongback by a washer a large wingnut, and hand tightened. In this way, a simple means of emergency exits provided without the need for tools, should personnel be cut off from the normal access doors, while maintaining a normal security posture from the outside. See below for further details.

### DIAGRAM OF STRONGBACK AND J-BOLT SECURING DEVICE

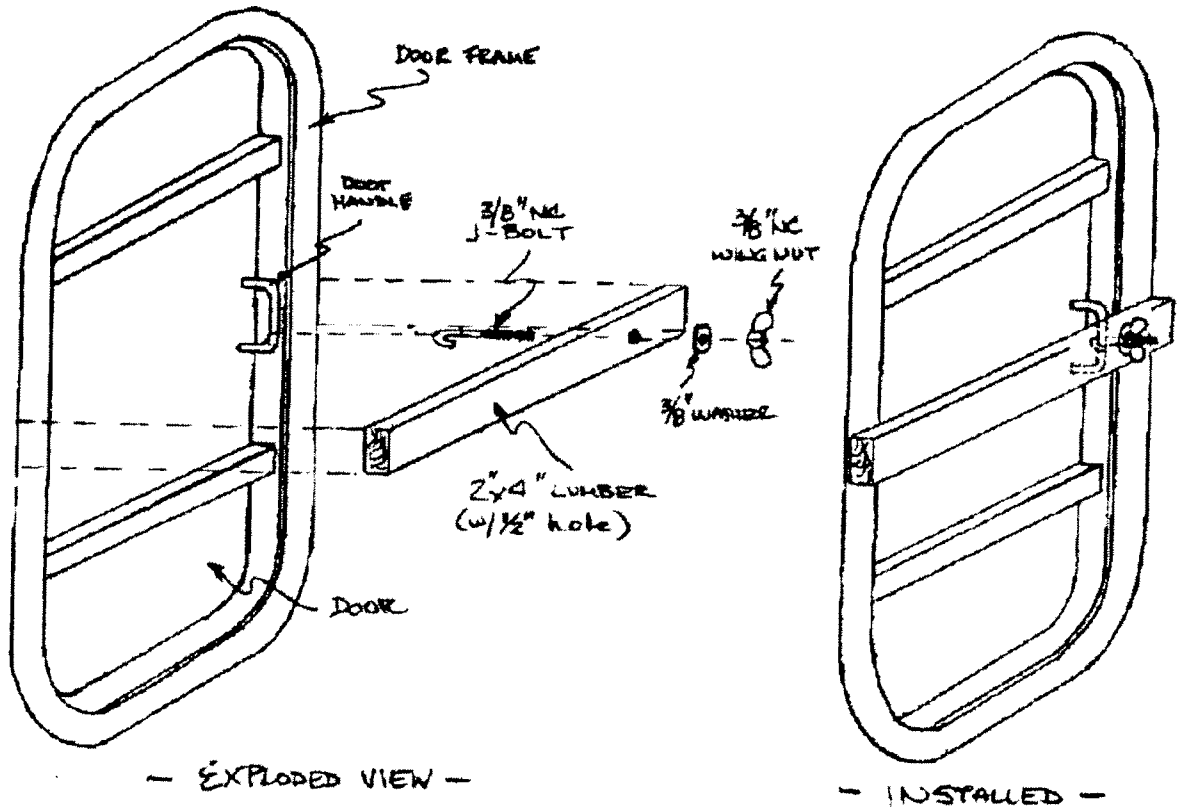

NOTE: J-BOLT CAN BE ADAPTED TO HOOK ON PULLS, DOGS, DOOR KNOBS, ETC...

# RUDDER LOCK AND SHAFT LOCK DIAGRAMS

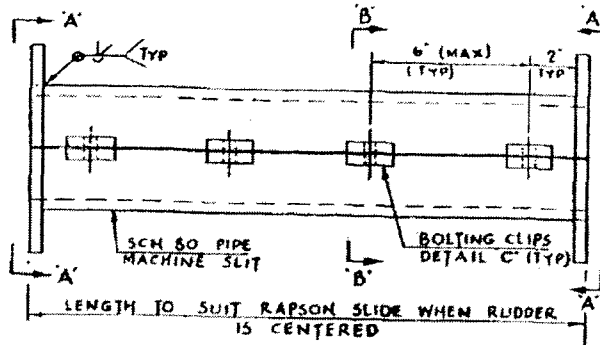

- GENERAL NOTES
1. ALL MATERIAL SHALL BE ABS GRADE 'A' OR ASTM A36.
  2. ALL WELDING SHALL BE IN ACCORDANCE WITH ABS RULES.
  3. ALL SHARP EDGES SHALL BE GROUND SMOOTH.
  4. THIS LOCKING DEVICE IS FOR USE ON VESSELS TO BE GIVEN OVER FOR MARAD CUSTODY. INSPECTION OF THE INSTALLATION OR DEVIATION FROM THIS STANDARD ARE AT THE DISCRETION OF THE ATTENDING REGION SURVEYOR.

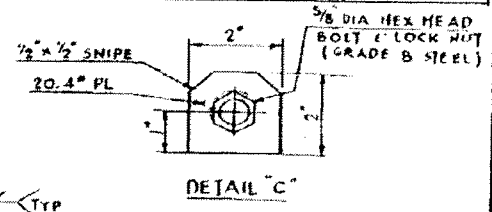
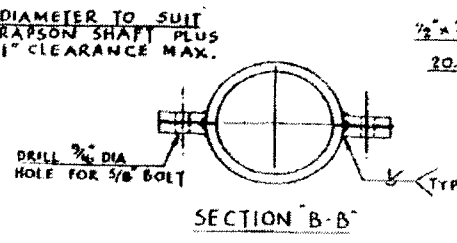
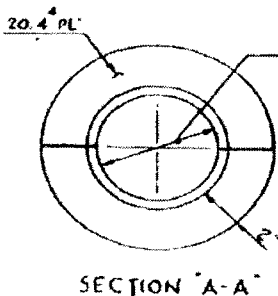

MARITIME ADMINISTRATION STANDARD  
RUDDER LOCKING DEVICE

3-26-86 SHJ N°

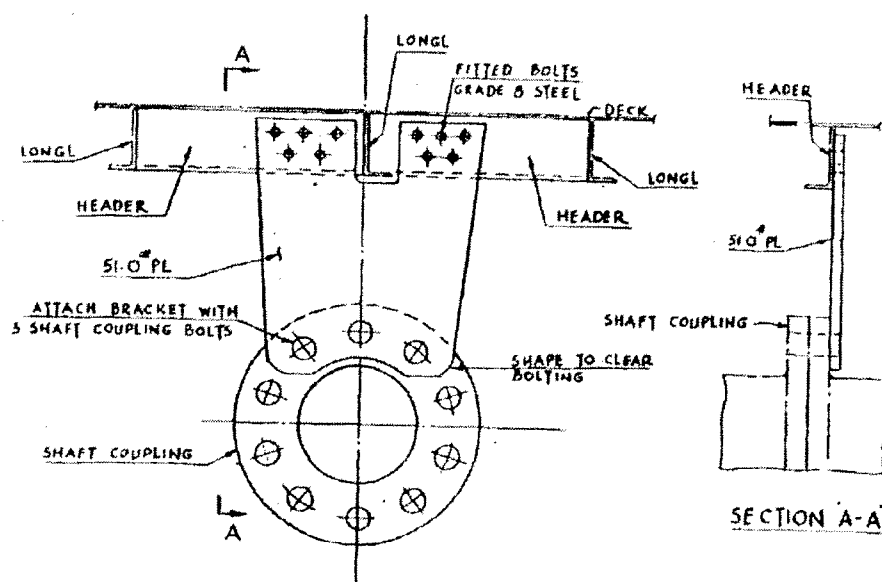

- GENERAL NOTES
1. ALL MATERIAL SHALL BE ABS GRADE 'A' OR ASTM A36.
  2. ALL WELDING SHALL BE IN ACCORDANCE WITH ABS RULES.
  3. ALL SHARP EDGES SHALL BE GROUND SMOOTH.
  4. THIS LOCKING DEVICE IS FOR USE ON VESSELS TO BE GIVEN OVER FOR MARAD CUSTODY. INSPECTION OF THE INSTALLATION OR DEVIATION FROM THIS STANDARD ARE AT THE DISCRETION OF THE ATTENDING REGION SURVEYOR.

MARITIME ADMINISTRATION STANDARD  
SHAFT LOCKING DEVICE

3-26-86 SHJ N°