



# Leveraging Acquisition: The New Cyber Acquisition Model

**Col Christopher Kinne**  
Director of combined Cyber SPO

**Col Paul Welch**  
688 IOW/CC



# Cyber Threat/Opportunity Space

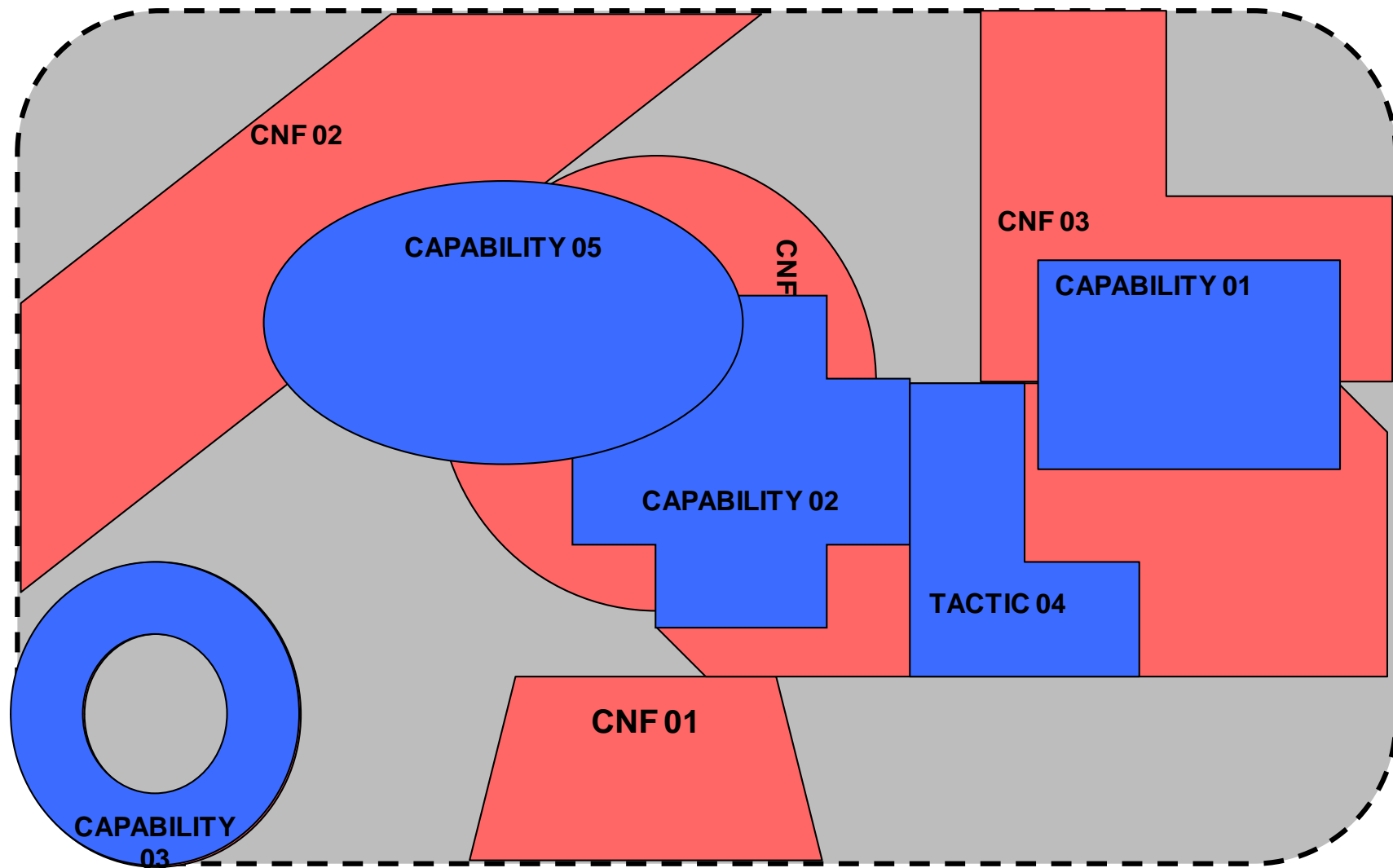

# Cyber Needs Management Flow

## Process Flow

## Improvements

Document Cyber Needs (CNF)

Rvw current CNFs: ID overlap, refine/rescope

Store Needs Data

Account for external requirements tracking

Publish Needs Data (SharePoint)

ID collaboration needs; revise as needed

Refine/Deconflict/Correlate Needs Data

Tech mgr/team works w/CNF POCs, refines needs

Triage/Prioritize Needs

Document triage/prioritization ROE, goals & responsibilities (charter). Hold regular & pop-up meetings with agendas, minutes, action items

Solicit/Review/Prioritize sol'n COAs

Collect/rvw all-source sol'n COAs; prioritize by impact/practicality/timeline; provide AFSPC/A3 w/CNF & sol'n vectors for non-organic COAs

Authorize Selected COAs, set timelines

Document 24 AF/CC-authorized sol'n COAs; provide plan w/milestones & timelines; Pgm resources and/or submit unfunded requests

Assess sol'n COAs Effectiveness

Track COA progress; update DB as sol'ns fielded

Gap  
Analysis

# Cyber Needs to Solution Process Flow

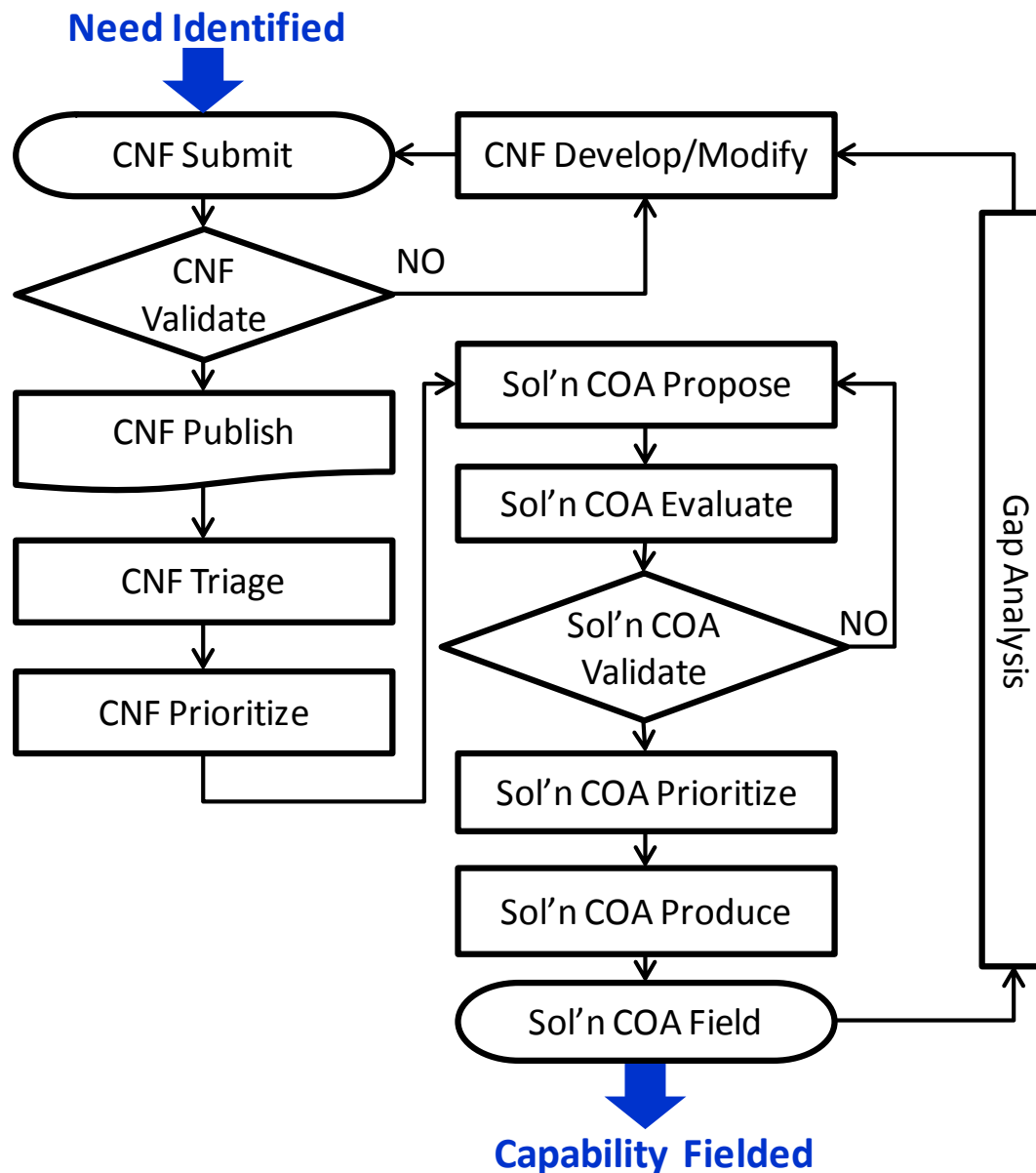



# 688th Ops & Engineering Posture



# Responsive Cyber Capability Development / Acquisition



## Key Players

HAF A3/5 / SAF/AQ  
AFSPC CTs / ESC SPO(s)  
24 AF / 688 IOW / 67 NWW  
AFRL / Sister Services  
Nat'l Labs / Vendors

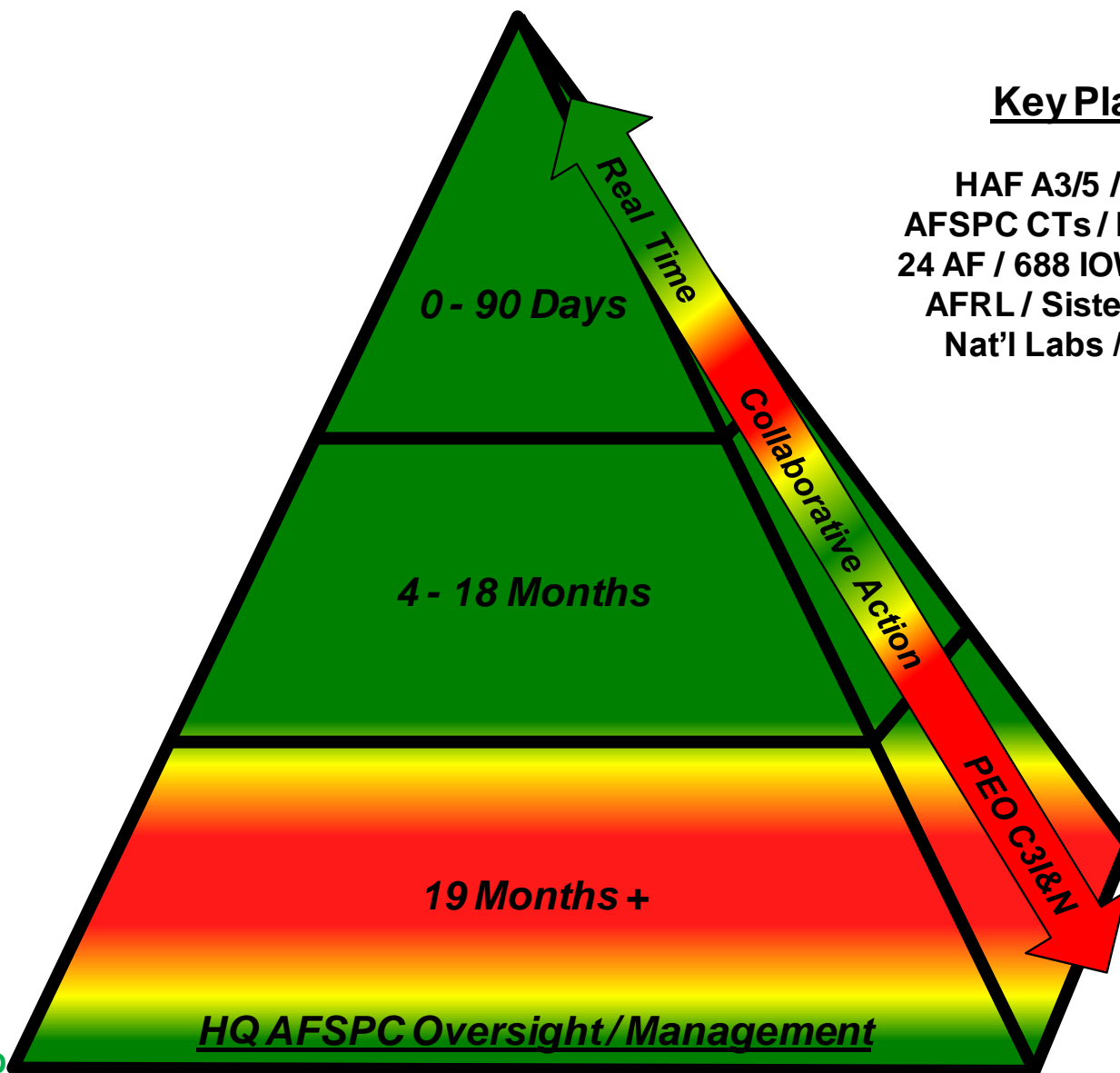



# Previous Cyber Organization

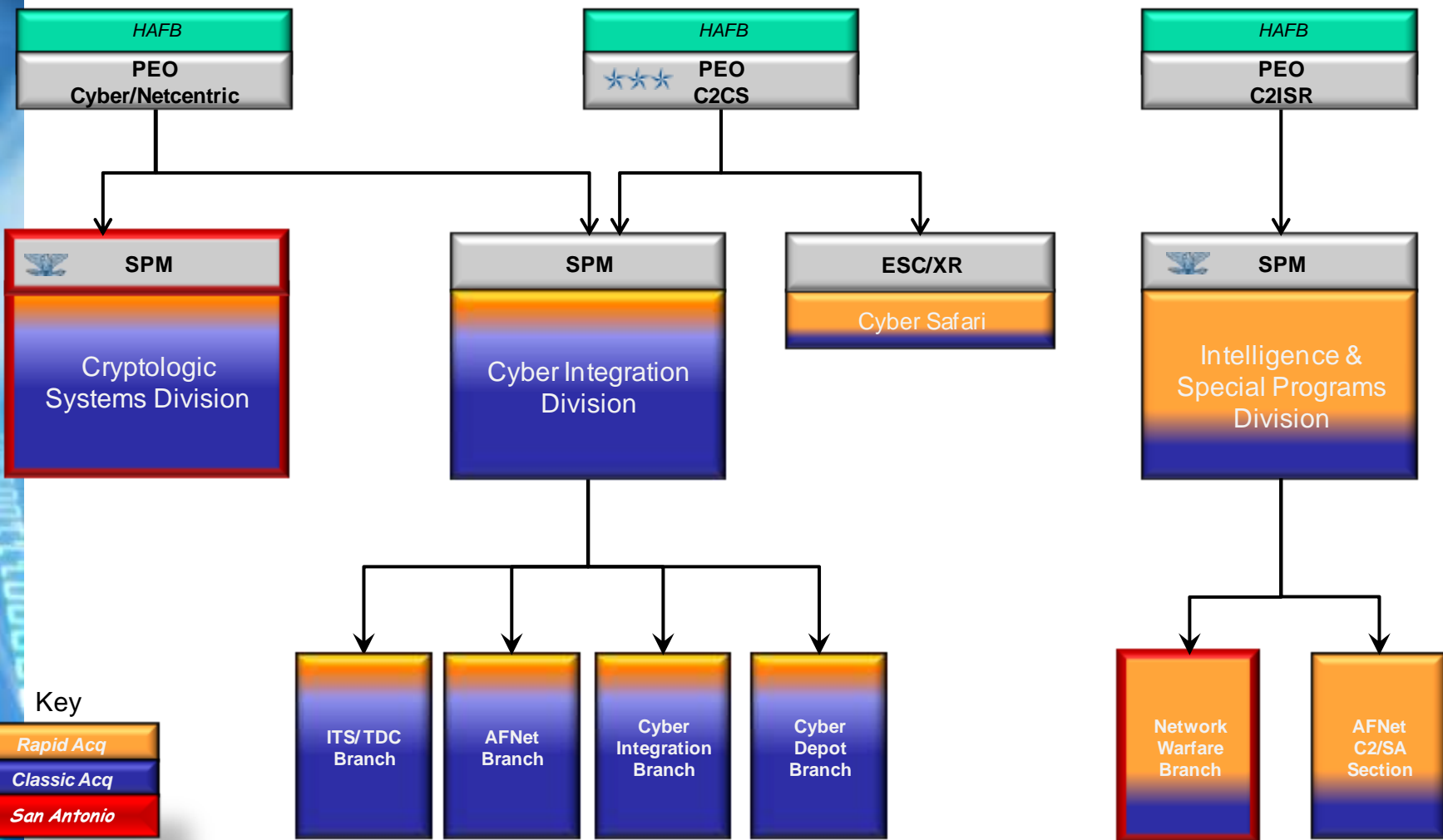

# Responsive Cyber Organization



### Key

- Rapid Acq
- Classic Acq
- San Antonio

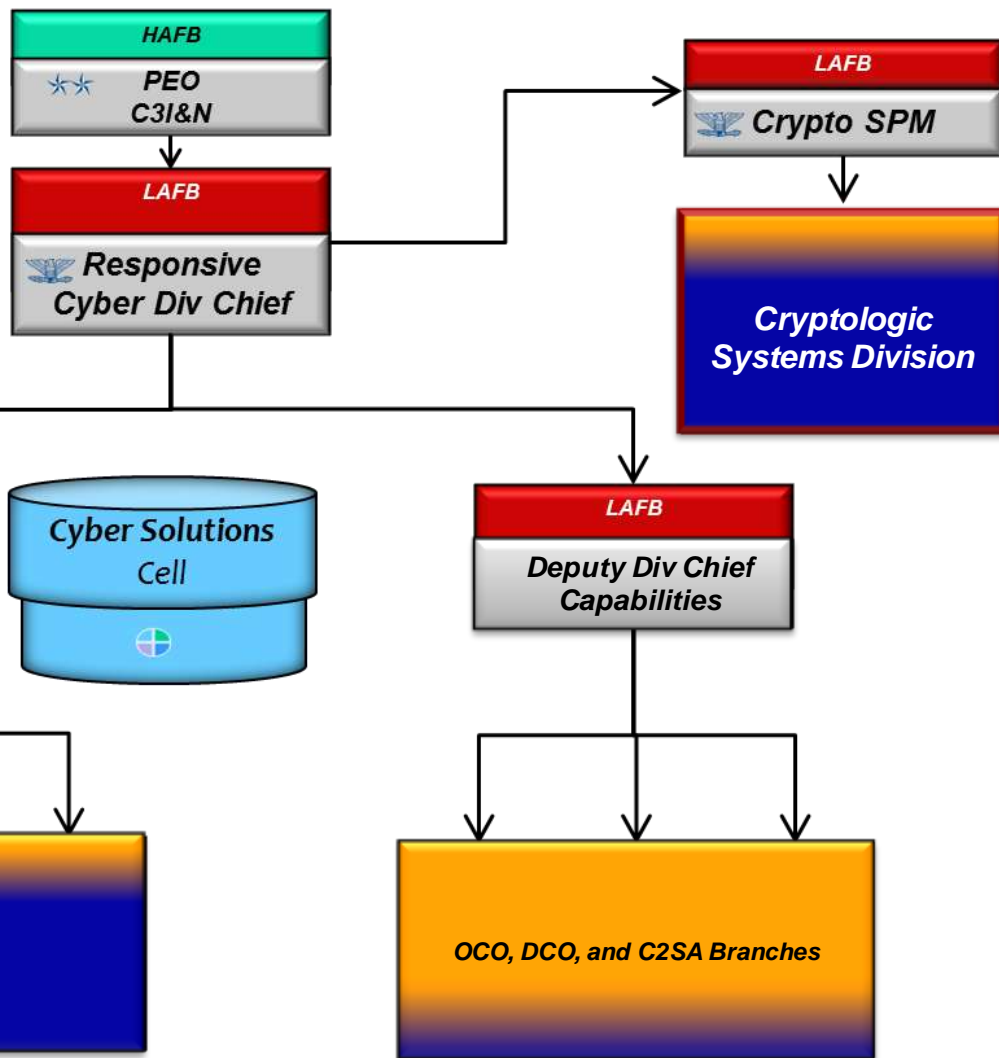





# Defense Acquisition Framework

Version 5.4 15 June 2008

## Integrated Defense Acquisition, Technology, and Logistics Life Cycle Management System

Following the Material Development Decision, the Milestone Decision Authority may authorize entry into the acquisition process at any point, consistent with phase-specific entrance criteria and statutory requirements

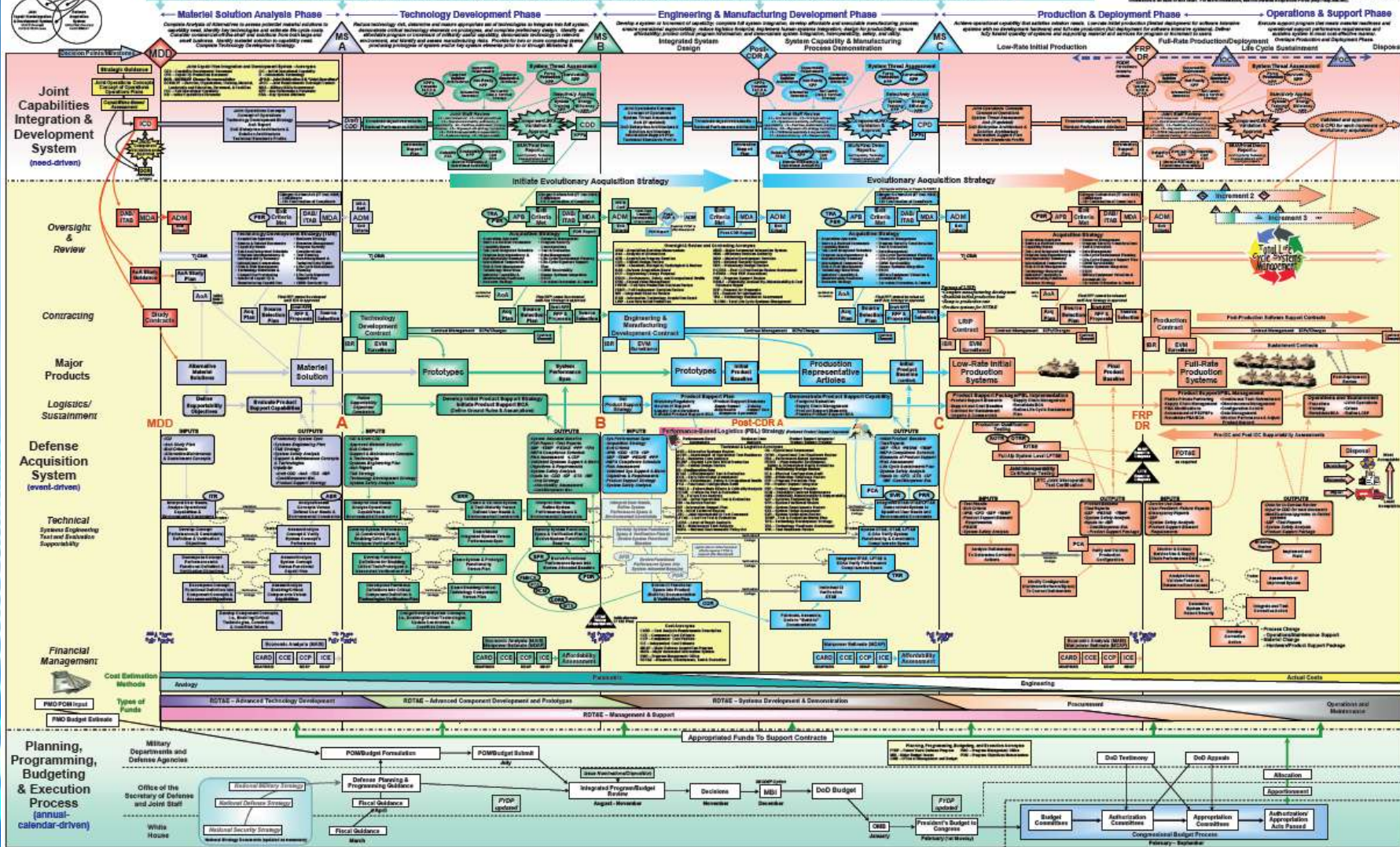

# Focus Areas for Responsive Cyber Acquisition



(tailored DoDI 5000 includes Sec 933 inputs  
And reflects Offensive Cyber Production Line)

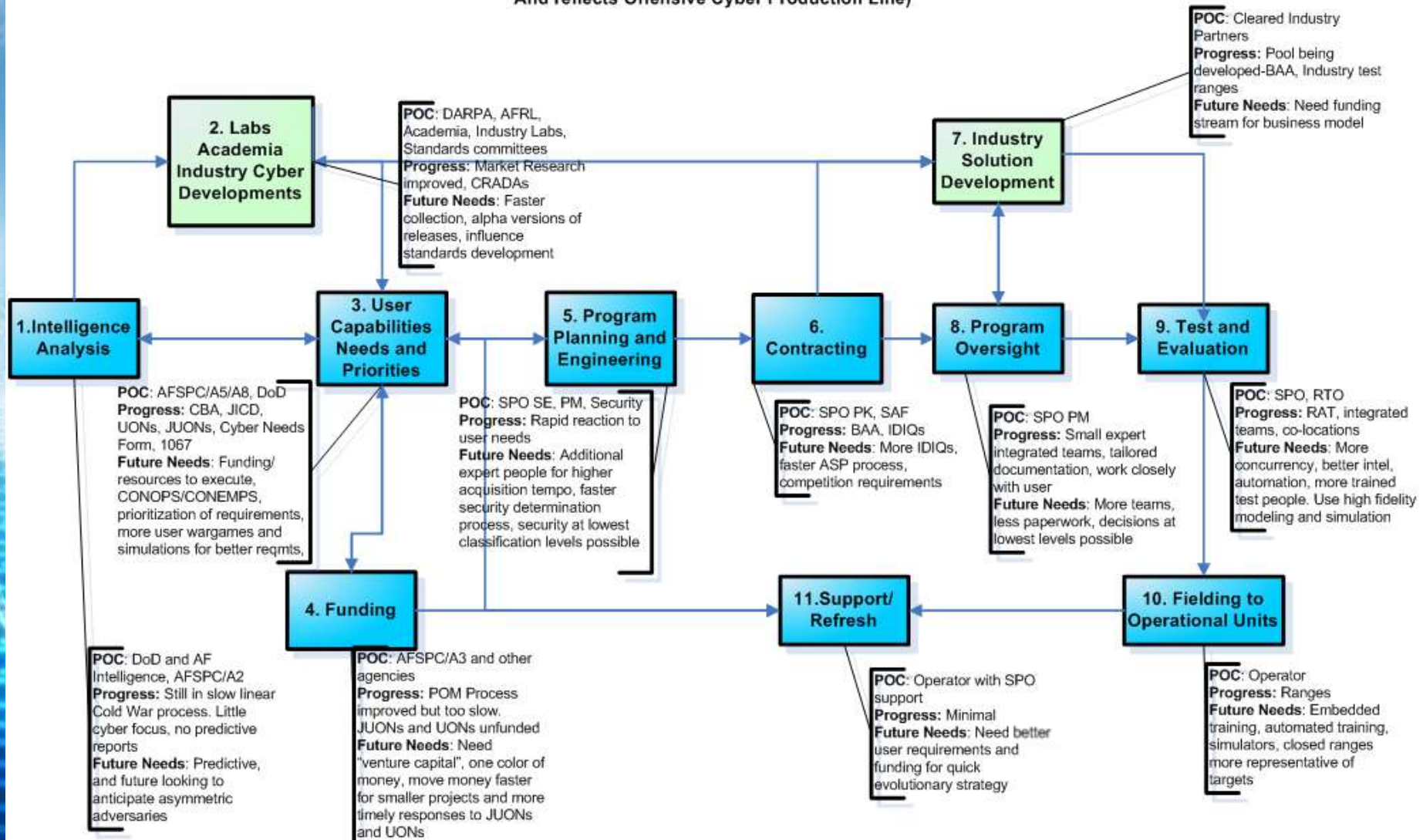



# Cyber Production Line

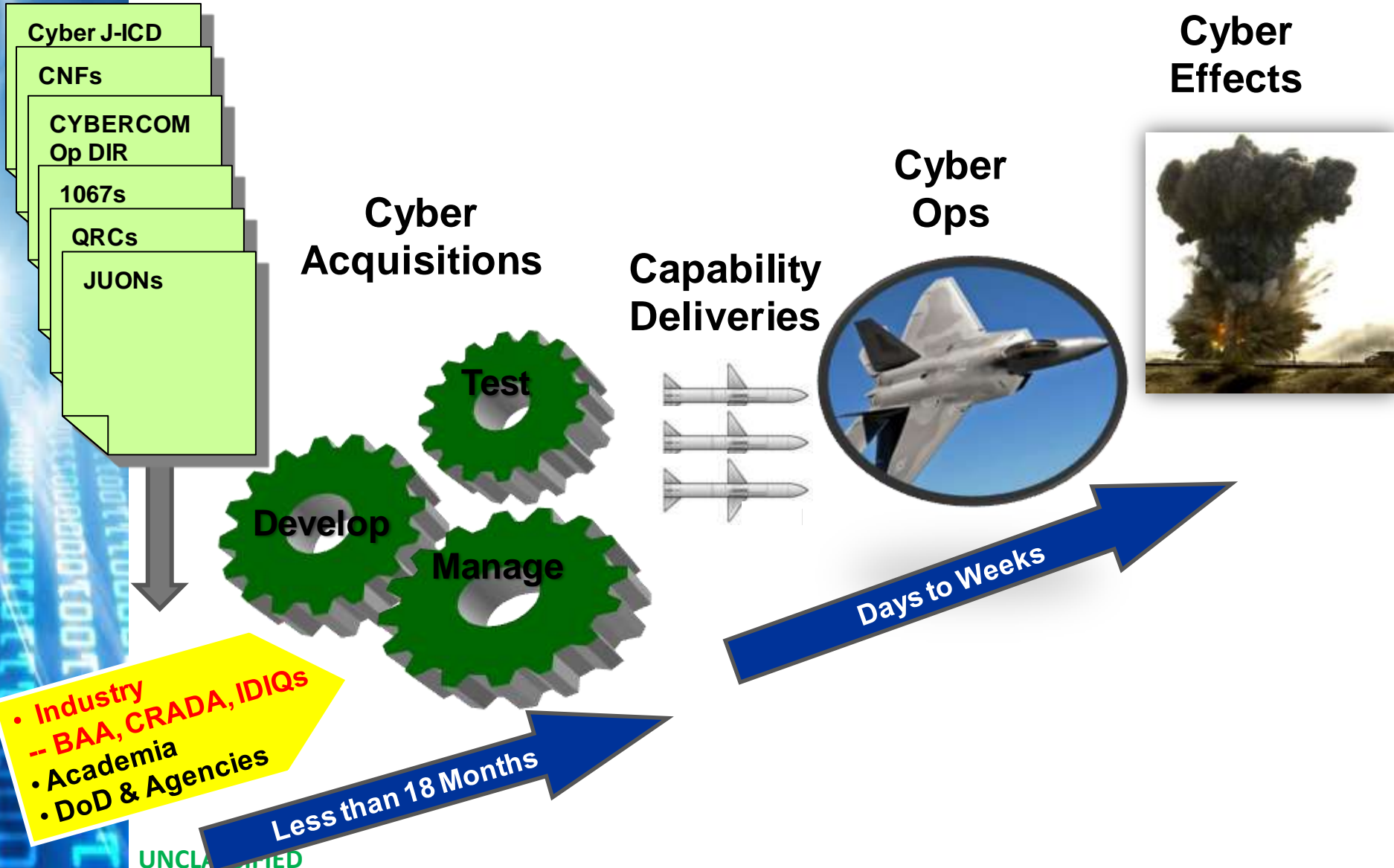



# Way Ahead

- ✪ Establishing new AF Partnerships to improve Rapid Cyberspace domain
  
- ✪ Work with AF & OSD to improve Cyber acquisition policy and processes
  - Implement best practices
  - Develop flexible funding authorities
  - Consistent with Cyber Vision 2025 and OSD Section 933



Questions?

