

Clean Coal Technology

DOE/NETL-2004/1203

500-MW Demonstration of Advanced Wall-Fired Combustion Techniques for the Reduction of Nitrogen Oxide (NO_x) Emissions from Coal-Fired Boilers

A DOE Assessment

U. S. Department of Energy
Office of Fossil Energy
National Energy Technology Laboratory

March 2004



Disclaimer

This report was prepared as an account of work sponsored by an agency of the United States Government. Neither the United States Government nor any agency thereof, nor any of their employees, makes any warranty, express or implied, or assumes any legal liability or responsibility for the accuracy, completeness, or usefulness of any information, apparatus, product, or process disclosed, or represents that its use would not infringe privately owned rights. Reference therein to any specific commercial product, process, or service by trade name, trademark, manufacturer, or otherwise does not necessarily constitute or imply its endorsement, recommendation, or favoring by the United States Government or any agency thereof. The views and opinions of authors expressed therein do not necessarily state or reflect those of the United States Government or any agency thereof.

Contents

Executive Summary	6
I Introduction	10
II Project/Process Description.....	11
II.A Potential of the Technology	11
II.B Project Description	11
II.C Coal Properties	13
II.D Chemistry of NO _x Formation and Removal	13
II.D.1 NO _x Control	14
II.E Technology Description.....	14
II.E.1 Advanced Overfire Air (AOFA).....	14
II.E.2 Low-NO _x Burners	15
II.E.3 Generic NO _x Control Intelligence System (GNOCIS).....	17
II.E.4 Total Plant Optimization Software	19
II.E.5 Intelligent Sootblowing System.....	20
II.E.6 Real-Time Heat Rate Package	21
II.E.7 ESPert	21
II.F Project Objectives and Statement of Work.....	22
III Technical and Environmental Assessment	23
III.A Technical Results	23
III.A.1 Description of the Test Program	23
III.A.2 Discussion of Results from Phases 1, 2, 3A, and 3B.....	24
III.A.3 Comparison of Phases 2, 3A, and 3B Results to Baseline.....	32
III.A.4 Phase 4A—DCS Testing.....	36
III.A.5 Phase 4B—GNOCIS Testing.....	38
III.A.6 Phase 4C—Unit Optimization Studies.....	38
III.B Environmental Performance.....	41
III.B.1 NO _x Emissions.....	41
III.B.2 Ash Disposal and Utilization.....	41
III.B.3 GNOCIS	42
IV Market Analysis.....	43
IV.A Market Size.....	43

IV.B Economics.....	43
IV.B.1 Capital Cost.....	43
IV.B.2 Operating Cost.....	44
IV.B.3 Economic Analysis.....	44
V Conclusions.....	47
Acronyms and Abbreviations.....	48
References.....	50
Bibliography.....	51

Figures

Figure 1. Advanced Overfire Air System	15
Figure 2. Boundary Air System	16
Figure 3. Controlled Flow/Split Flame Low NO _x Burner	17
Figure 4. Baseline NO _x Emissions	25
Figure 5. NO _x Emissions with only AOFA Implemented.....	27
Figure 6. Excess Oxygen as a Function of Load	27
Figure 7. 30 Day Rolling Average NO _x Emissions.....	28
Figure 8. NO _x Emissions as a Function of Excess Oxygen at a Load of 480 MWe	28
Figure 9. NO _x Emissions with only LNBs Implemented	30
Figure 10. NO _x Emissions with LNBs plus AOFA Implemented.....	32
Figure 11. NO _x Emissions as a Function of Load	33
Figure 12. NO _x Reductions from Baseline as a Function of Load.....	33
Figure 13. CO Emissions as a Function of Load	34
Figure 14. NO _x Emissions and LOI with DCS Installed.....	37
Figure 15. Long-Term NO _x Emissions with DCS Installed.....	37

Tables

Table 1. Analyses of Coal Burned During Performance Testing	13
Table 2. Combustion Tuning Control Points	18
Table 3. Testing Schedule for Phases 2, 3A, and 3B.....	24
Table 4. Phase 2 Performance Tests Summary.....	26
Table 5. Phase 3A Performance Tests Summary.....	29
Table 6. Parameters Tested in Special LOI Tests	30
Table 7. Phase 3B Performance Test Summary.....	31
Table 8. Full-Load LOI Levels	34
Table 9. Impact on Full-Load (480 MWe) Unit Heat Rate.....	35
Table 10. Impacts of Low-NO _x Technologies on Boiler Performance	36
Table 11. Phase 4A Performance Test Summary	36
Table 12. System Performance Data.....	45
Table 13. Capital Charge and Levelizing Factors.....	45
Table 14. Economics for Adding NO _x Control to a 500-MWe Wall-Fired Boiler	46
Table 15. Economics for Adding GNOCIS Technology to a 500-MWe Wall-Fired Boiler.....	46

Executive Summary

Through demonstration projects funded under the Clean Coal Technology (CCT) Program, the U.S. Department of Energy (DOE) seeks to furnish the energy marketplace with advanced, more efficient, and environmentally responsible coal utilization technologies. This document is a post-project assessment of a project selected in CCT Round II, entitled “500 MW Demonstration of Advanced Wall-Fired Combustion Techniques for the Reduction of Nitrogen Oxide (NO_x) Emissions from Coal-Fired Boilers.”

In December 1989, Southern Company Services (SCS) entered into a cooperative agreement with DOE to conduct a project to demonstrate that NO_x, an air pollutant of major concern, could be significantly better controlled in wall-fired furnaces by installing two commercially available low-NO_x combustion technologies: low-NO_x burners (LNBs) and advanced overfire air (AOFA). Later, the project was expanded to include testing of the Generic NO_x Control Intelligent System (GNOCIS), a computer software package designed to further improve boiler efficiency and reduce emissions by determining and maintaining optimum control settings for the combustion equipment. Still later, based on the success of the GNOCIS tests, the project was further expanded to include optimization of other unit components, such as the electrostatic precipitator (ESP), sootblowers, and steam turbine, as well as the entire unit. DOE provided 41 percent of the total \$15.9 million in project funds.

The target for the project was to achieve at least 50 percent NO_x reduction using a combination of combustion modifications (LNBs plus AOFA). Specific objectives of the project were:

- To demonstrate in a logical stepwise fashion the short-term NO_x reduction capabilities of two advanced low-NO_x combustion technologies: AOFA, LNBs, and LNBs plus AOFA.
- To determine the dynamic, long-term emissions characteristics of each of these NO_x reduction methods using statistical techniques.
- To evaluate the progressive cost effectiveness (dollars per ton of NO_x removed) of the low-NO_x combustion techniques tested.
- To evaluate advanced digital control and optimization techniques as applied to reduce NO_x emissions, mitigate adverse impacts of LNBs and AOFA, and improve boiler efficiency.

Principal team members include Southern Company Services (SCS), project manager and cofunder; Electric Power Research Institute (EPRI), cofunder and technology provider; Foster Wheeler Energy Corporation, technology supplier; Georgia Power Company, host site provider; PowerGen, cofunder; United Kingdom Department of Trade and Industry, cofunder; Energy Technology Consultants, Inc. (EnTEC), test coordinator; Radian International, environmental reporting and chemical emissions testing; Tennessee Technological University, technology supplier; W.S. Pitts Consulting, Inc., statistical analysis of long-term data; and Spectrum Systems, Inc., instrument operation and maintenance.

Unit 4 at Georgia Power Company’s Plant Hammond generating station, a 500-MWe opposed wall-fired, balanced draft boiler served as the host site for the project. NO_x control technologies installed at the plant include a Foster Wheeler AOFA system, whose purpose was to introduce air through overfire air ports in the front and rear walls of the furnace, and Foster Wheeler’s Controlled Flow/Split Flame Low-NO_x burners designed to achieve controlled fuel/air mixing on a localized, individual burner basis. In the final phase of the program, a Foxboro I/A Series

distributed control system (DCS), EPRI's GNOCIS boiler software package, EPRI's ESPert ESP package, PowerGen's Intelligent Sootblowing System, and a real-time heat rate package developed by Tennessee Tech were installed.

AOFA technology reduces NO_x formation by staging the introduction of air into the flame zone of a boiler. Air is fed to the burner at the lowest air/fuel ratio that will maintain combustion while controlling production of H₂S in the lower portion of the furnace. The AOFA concept feeds air through a separate ductwork system and into the boiler through high velocity ports located in the front and rear walls of the furnace. With this system, air is introduced in larger volume, at higher pressure and with more control, resulting in deeper staging of the combustion process than was achievable previously.

LNBS reduce NO_x formation by limiting the mixing of coal and air as they are introduced into the furnace. LNBS regulate the initial fuel/air mixture, velocities, and turbulence to create a fuel-rich core with sufficient air to sustain combustion. The burner then controls the rate at which the "secondary" air necessary to complete combustion is mixed with the flame to maintain a deficiency of oxygen until the remaining combustibles fall below the peak NO_x-producing temperature (around 2,800 °F). The final excess air is then allowed to mix with the unburned products so that combustion is completed at a lower temperature, favoring the formation of molecular nitrogen, rather than NO_x.

GNOCIS, a software package developed to improve utility boiler efficiency and reduce NO_x emissions, uses a neural network that models the system's responses to changes in operating conditions. Initially, historical data are fed to the computer, which "learns" to associate furnace responses with inputs. The training phase is time consuming, but once a network has been trained, it responds very rapidly to new inputs. GNOCIS, in conjunction with an advanced digital control system (ADC), can be operated either open-loop or closed-loop to provide and maintain optimum settings for the combustion equipment.

The success of the GNOCIS tests on the boiler prompted the extension of the project to include optimization of other components of the unit, such as the sootblowers, the ESP, the steam turbine, as well as the entire unit. Software packages installed on the unit include EPRI's ESPert program, PowerGen's Intelligent Sootblowing System (ISBS), a real-time heat rate package, developed by the Center for Electric Power, and Synengco's SentinentSystem Global Optimizer software. In addition, GNOCIS was modified for use in optimizing steam turbine operations.

Installation of AOFA and LNB project hardware was initiated in 1990 and completed in 1991. The ADC system was installed in 1993. The multi-phased testing program, begun in 1990, included the following:

- Establishing a baseline for the Plant Hammond Unit 4 (Phase 1)
- Operating the unit using AOFA (Phase 2)
- Operating the unit using LNBS (Phase 3A)
- Operating the unit using LNBS plus AOFA (Phase 3B)
- Testing the unit using LNBS plus AOFA with ADC (Phase 4A)
- Testing the unit using LNBS plus AOFA with GNOCIS (Phase 4B)
- Testing individual component optimization packages and overall unit optimization (Phase 4C)

The test program was designed with the underlying premise that long-term steady-state operation

is required to adequately characterize emissions from a utility boiler. Thus, Phases 2, 3A, and 3B concentrated on long-term characterization tests, with short-term diagnostic testing used only to establish emission trends of the unit over the range of normal operating conditions.

Baseline testing, with no attempt to optimize operations, resulted in NO_x emissions levels of 1.1 to 1.45 lb/10⁶ Btu over the load range of 200 to 500 MWe. Carbon monoxide (CO) emissions were generally below 100 ppm over the load range. Loss on ignition (LOI) at full load was 5 percent. Phase 2 testing (AOFA) resulted in NO_x emissions of about 0.9 lb/10⁶ Btu, almost independent of system load. CO levels averaged less than 15 ppm at all load levels, and LOI was generally between 5 and 10 percent.

In Phase 3A testing (LNBS), NO_x emissions showed more of a dependence on load than for baseline or Phase 2; they were higher at low and high loads and lower at midloads. NO_x varied from about 0.5 to 0.7 lb/10⁶ Btu. CO emissions were less than 20 ppm over the entire load range. In Phase 3B testing (LNBS plus AOFA), NO_x emissions were about 0.4 lb/10⁶ Btu, except for loads below 200 MWe, when they were slightly higher. CO was less than 50 ppm for loads below 250 MWe, but increased considerably at higher loads. LOI was between 6 and 8 percent.

In summary, full-load NO_x emissions were reduced from about 1.2 lb/10⁶ Btu at baseline conditions to 0.4 lb/10⁶ Btu for LNBS plus AOFA. Full-load reductions were about 20, 50, and 65 percent respectively for AOFA, LNBS, and LNBS plus AOFA.

Both adverse and beneficial impacts on Plant Hammond Unit 4 operation were experienced after the retrofit of AOFA and LNBS. Adverse effects included: (1) higher excess oxygen, (2) higher LOI, and (3) increased dust loading and gas flow into the marginally sized ESP, which resulted in temporarily derating the unit. This latter effect was deemed primarily a result of an inadequately sized ESP, and should not be attributed to shortcomings in the AOFA or LNB technologies. The main beneficial effect, in addition to NO_x reduction, was a significant reduction in waterwall slagging, probably due to the changed chemistry and temperature profile in the boiler.

In Phase 4B, open- and closed-loop testing was conducted using the GNOCIS program to control boiler operations. In open-loop operation, GNOCIS provides recommended control settings that the operator can implement; in closed-loop operation, GNOCIS actually changes the control settings. When operated in the minimize NO_x mode, full-load NO_x emissions were reduced by about 14 percent, and averaged 11 percent below baseline over the entire load range. The maximize efficiency operating mode reduced NO_x emissions by 12 percent at full load, but at loads below 340 MWe, NO_x increased, so that the average over the load range was close to 0 percent. System efficiency improved about 1 percent at full load, while averaging about 0.7 percent over the load range. In the minimize LOI mode, NO_x averaged 6 percent over baseline. At full load, the difference in LOI between the minimize NO_x mode and the minimize LOI mode was about 4 percent, but at low load, the difference was only about 1 percent.

This project showed that the combination of LNBS plus AOFA is relatively efficient at achieving NO_x reduction. This combination of technologies is able to achieve almost 70 percent NO_x reduction at a cost of about \$130/ton on a constant dollar basis (\$170/ton on a current dollar basis). This is considerably cheaper than costs for selective catalytic reduction (SCR) and selective noncatalytic reduction (SNCR), provided 70 percent removal is sufficient to meet permit requirements, and LOI is not a problem. If higher than 70 percent NO_x removal is

required, LNBS plus AOFA can be installed in conjunction with SCR or SNCR, thus reducing the size of these post-combustion facilities and reducing overall costs.

If a DCS is present, installing GNOCIS on the boiler is relatively inexpensive and can significantly improve plant operations. As part of this project, optimization packages were installed on other plant units, such as the sootblowers, ESP, and turbine, and these packages were tied into a top-level global optimizer. This approach holds great promise for further improvements in power plant operations. However, by the end of the cooperative agreement, although this system was functional, not enough test time had occurred to quantify the benefits.

This was a successful project that achieved its objective of demonstrating that low-NO_x burners plus AOFA can be installed on a wall-fired boiler and significantly decrease NO_x emissions. The project also showed that optimization software, such as GNOCIS, ISBS, and ESPert, can be successfully installed on a power plant and show potential for improving economics and mitigating some of the negative effects of LNBS, such as increased LOI and decreased efficiency.

I Introduction

The U.S. Department of Energy's (DOE) Clean Coal Technology (CCT) Program seeks to offer the energy marketplace more efficient and environmentally benign coal utilization technology options by demonstrating these technologies in industrial settings. This document is a DOE post-project assessment (PPA) of one of the projects selected in Round II of the CCT Program, the 500-MW Demonstration of Advanced Wall-Fired Combustion Techniques for the Reduction of Nitrogen Oxide (NO_x) Emissions from Coal-Fired Boilers, initially described in a Report to Congress (Department of Energy 1989).

The desire to demonstrate advanced techniques for controlling NO_x emissions from a wall-fired boiler prompted Southern Company Services, Inc. (SCS) to submit the proposal for this project. In December 1989, SCS entered into a cooperative agreement with DOE to conduct the project, which was sited at Georgia Power Company's Plant Hammond, located near Coosa, Georgia. As originally planned, the purpose was to demonstrate NO_x control by installing low-NO_x burners (LNBS) and advanced overfire air (AOFA) on a wall-fired boiler. Later, the scope was broadened to include testing the Generic NO_x Control Intelligent System (GNOCIS) computer software. GNOCIS was developed by a consortium consisting of DOE, Electric Power Research Institute (EPRI), PowerGen, Southern Company, and URS. In September 1999, the cooperative agreement was expanded to include testing of additional power plant optimization software. DOE provided 41 percent of the total \$15.9 million project funds.

The independent evaluation contained herein is based primarily on information from final reports prepared by Southern Company Services and other references cited.

II Project/Process Description

II.A Potential of the Technology

NO_x is an air pollutant of major concern. It is not only implicated in smog formation, but also contributes to eutrophication of ponds and lakes and acidification of forest soils. A major source of NO_x has been coal-burning power plants. The technologies implemented in this project (LNBS and AOFA) can reduce NO_x levels from wall-fired furnaces by 50 to more than 70 percent. Furthermore, these technologies are relatively inexpensive to install, thus providing low NO_x removal costs. Additional NO_x reduction can occur through online process optimization.

The testing of LNBS and AOFA in this project occurred in the early 1990s. This work proved the applicability and effectiveness of these technologies when applied to a wall-fired boiler. Successful implementation of LNBS/AOFA at Plant Hammond Unit 4 has been followed by numerous additional commercial installations of these technologies. Further improvements by equipment suppliers have resulted, at least in part, because of the success of the Hammond project.

Because of the NO_x reduction potential of LNBS/OFA, the Department of Energy has sponsored a series of projects on different burner configurations using this technology. In addition to the wall-fired project discussed here, projects were also sponsored on a tangentially fired boiler, a down-fired boiler, and a boiler with cell burners. All these projects demonstrated that significant NO_x reduction can be achieved by combustion modifications.

Computer technology offers the potential to significantly enhance the benefits of LNB/AOFA installations by continuously optimizing control settings as system operating parameters change. One such program, GNOCIS, can detect the underlying pattern in the complex mass of data emanating from a modern boiler and devise an optimum control strategy that leads to improved operations (increased NO_x removal and higher boiler efficiency). Efficiency can be further enhanced by using appropriate software to optimize other parts of the power plant (electrostatic precipitator, sootblowers, turbine, etc.), as well as the entire plant.

II.B Project Description

Plant Hammond consists of four pulverized coal units. Units 1, 2, and 3 are 100-MWe Babcock and Wilcox wall-fired units. Unit 4, the host unit for this project, is a Foster Wheeler Energy Corporation (FWEC) opposed wall-fired boiler, rated at 500-MWe gross, with design steam conditions of 2,400 psig and 1,000 °F/1,000 °F superheat/reheat temperatures. It was placed into service in 1970 and was originally designed for pressurized furnace operation, but was converted to balanced draft operation in 1977. At the time this project started, Unit 4 was fitted with six FWEC planetary roller and table type mills, which provided pulverized Eastern bituminous coal to 24 pre-New Source Performance Standards (NSPS), FWEC intervene burners. The 24 burners are arranged with twelve on the front wall and twelve on the back wall in four wide by three high grids. Each mill provides coal to four adjacent burners on the same level. The unit is equipped with a selective catalytic reduction (SCR) unit, a cold side electrostatic precipitator (ESP), two regenerative primary air heaters, and two regenerative secondary air heaters.

The project was conducted in test phases, as follows:

- Phase 1 - Baseline
- Phase 2 - AOFA
- Phase 3A - LNBS
- Phase 3B - LNBS plus AOFA
- Phase 4A - Advanced digital control system (ADC)
- Phase 4B - GNOCIS
- Phase 4C - Other optimization software

Results from Phases 1, 2, and 3 indicated that careful control of operating parameters had the potential to further reduce NO_x and improve boiler performance by mitigating the adverse impacts of the LNB retrofit, such as increased loss on ignition (LOI) of the ash and reduced efficiency. This led to the decision to add Phase 4, which was not part of the original scope. Hazardous air pollutants (HAPs) testing, also not part of the original scope, was conducted during Phases 2 and 3B by Radian Corporation (1992).

AOFA was installed during April and May 1990; the LNBS were installed during an outage that began on March 8, 1991, and ended May 5. Although not part of this project, during the time the project was conducted, Unit 4 was retrofitted with six Babcock and Wilcox MPS 75 mills (two during the spring 1991 outage, two during the spring 1992 outage, and the last two during the 1993-1994 outage).

From September 3, 1993, to June 5, 1994, Unit 4 underwent a major outage. Activities during this outage included:

- Installation of a Foxboro I/A distributed digital control system (DCS) to replace the Bailey pneumatic boiler control system used during Phases 1 through 3B. The DCS system was installed in preparation for testing the GNOCIS combustion optimization system.
- Installation of a new Research Cottrell ESP with a design collection efficiency of 99.65 percent.
- Upgrades to the steam turbine.
- Replacement of the two remaining original coal mills (Mills B and D).

Diagnostic and performance testing was conducted during August and November 1994 to determine performance and emissions characteristics following the outage. Online carbon-in-ash analyzers were tested during August 1995 and February 1996. GNOCIS testing commenced in February 1996, and initiation of other optimization efforts began in 1999. The project was completed in March 2003.

SCS managed this project on behalf of the Southern Company and the other project sponsors. Team members in addition to SCS included EPRI, cofunder and technology provider; Foster Wheeler Energy Corporation, technology supplier; Georgia Power Company, host site provider; PowerGen, cofunder; United Kingdom Department of Trade and Industry, cofunder; Energy Technology Consultants, Inc. (EnTEC), test coordinator; Radian International, environmental reporting and chemical emissions testing; Tennessee Technological University, technology supplier; Southern Company, cofunder; Spectrum Systems, Inc., instrument operation and maintenance; W.S. Pitts Consulting, Inc., statistical analysis of long-term data; and Synengco, optimizer software provider.

II.C Coal Properties

Unit 4 burns a low-to-medium reactivity Eastern bituminous coal. Table 1 shows typical analyses for the coal burned during the test program.

Table 1. Analyses of Coal Burned During Performance Testing

Property	Average Composition				
	Baseline	Phase 2	Phase 3A	Phase 3B	Phase 4
Proximate Analysis, wt% (as received)					
Moisture	4.28	5.60	5.69	6.42	6.0
Volatile Matter	33.39	33.27	32.57	33.65	32.0
Fixed Carbon	52.53	52.23	52.30	50.42	51.9
Ash	9.80	8.90	9.44	9.51	10.1
Ultimate Analysis, wt% (dry)					
Carbon	75.63	77.46	76.91	75.60	76.30
Hydrogen	4.90	5.00	4.95	4.98	4.95
Nitrogen	1.50	1.50	1.47	1.48	1.41
Sulfur	1.80	1.74	1.62	1.78	1.42
Chlorine	0.03	0.06	0.01	0.04	0.03
Oxygen	5.90	4.82	5.03	5.95	5.08
Ash	10.24	9.42	10.01	10.16	10.81
Heat of Combustion (wet), Btu/lb (HHV ^a)	12,920	13,000	12,869	12,494	12,600
Reactivity (FC/VM ^b)	1.57	1.57	1.61	1.50	1.62

^a Higher heating value

^b Fixed carbon/volatile matter

II.D Chemistry of NO_x Formation and Removal

NO_x is formed during combustion by several mechanisms (thermal NO_x, fuel NO_x, and prompt NO_x). Thermal NO_x results from the reaction of nitrogen in air with excess oxygen at elevated temperatures. At high temperature, both N₂ and O₂ are dissociated into atoms that react by the Zeldovich mechanism:

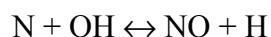

Nitric oxide (NO) is the principal reaction product. The major factors that affect thermal NO_x production are flame temperature, residence time at temperature, the degree of fuel/air mixing, and the concentrations of oxygen and nitrogen in the flame. Higher temperature, longer residence time, enhanced mixing, and higher oxygen concentration all favor NO_x formation.

One of the components of the organic matter in coal is nitrogen (typically 0.5 to 2 percent), believed to be present mostly in ring structures. Fuel NO_x results when this nitrogen is oxidized by combustion air. As pulverized coal is blown into the furnace, it is rapidly heated and devolatilized, with some of the nitrogen leaving as volatile species and some remaining with the

char. The volatile nitrogen compounds undergo various homogeneous reactions and are either reduced to N_2 or oxidized to NO. The nitrogen in the char reacts heterogeneously with oxygen to form NO. Ash remaining after char combustion is virtually nitrogen free. Fuel NO_x emissions are a strong function of fuel/air mixing. In general, any change that increases mixing between fuel and air during coal volatilization will dramatically increase volatile nitrogen conversion to NO_x .

Prompt NO_x is formed early in the combustion process through complex interactions that are not fully understood. Prompt NO_x is generally only a small contributor to total NO_x production.

II.D.1 NO_x Control

There are two fundamentally different approaches to NO_x control: (1) modify combustion conditions so that NO_x formation is reduced, and (2) add downstream processing to reduce NO_x to nitrogen. The most common combustion modifications are LNBS and overfire air (OFA). The most important post-combustion processes are selective catalytic reduction (SCR) and selective noncatalytic reduction (SNCR). Both these post-combustion processes inject ammonia or an ammonia precursor into the flue gas to react with NO_x and reduce it to N_2 .

II.E Technology Description

II.E.1 Advanced Overfire Air (AOFA)

Because NO_x formation is strongly dependent on flame zone stoichiometry, reducing excess air (air above the stoichiometric quantity required for complete combustion) in the flame zone will reduce NO_x formation. However, reducing excess air has a detrimental effect on furnace operation and results in incomplete combustion. To overcome this problem, the excess air diverted from the burners must be reintroduced higher in the furnace to complete combustion and maintain furnace efficiency. This air is referred to as overfire air (OFA). To achieve maximum NO_x reduction, air to the burners should be reduced to the lowest level that will maintain stable combustion. In theory, a minimum stoichiometric ratio of about 0.7 to 0.8 should be possible, but substoichiometric operation results in the production of hydrogen sulfide (H_2S) in the lower portion of the furnace, and H_2S can cause severe tube corrosion. To avoid this problem, burner stoichiometries of 1.0 to 1.2 are generally used.

Typical OFA systems accomplish staging by diverting 10 to 20 percent of the total combustion air to ports located above the primary combustion zone but within the same windbox as the primary air ports. AOFA improves on this concept by introducing the OFA through a separate ductwork system in larger volume and higher pressure and with more control. The resulting system is capable of providing deep staging of the combustion process with accurate measurement of the OFA flow.

The FWEC AOFA system diverts a maximum of 20 percent of the total combustion air from the secondary air ducts and injects it through high velocity ports located in the front and rear walls of the furnace. These ports are at a higher elevation than is used for conventional OFA. Certain characteristics of Hammond Unit 4 required some deviations from FWEC's standard AOFA design, as follows:

- Four AOFA ports were used on each wall, instead of the originally proposed six.

- Because of the short height of the boiler, the AOFA ports were located closer than preferred to the top row of burners (9 feet 2 inches above them).

Although these changes probably had a slight negative impact on NO_x reduction, they did not negate the value of the demonstration, because many other wall-fired units are subject to similar limitations.

To ensure optimum performance of the AOFA system, a burner/windbox air distribution system was installed at the same time as the AOFA system. The primary purpose of this system was to provide optimum distribution of combustion air between the front and rear windboxes and to serve as a backpressure damper to enable sufficient air flow to the AOFA system (Figure 1).

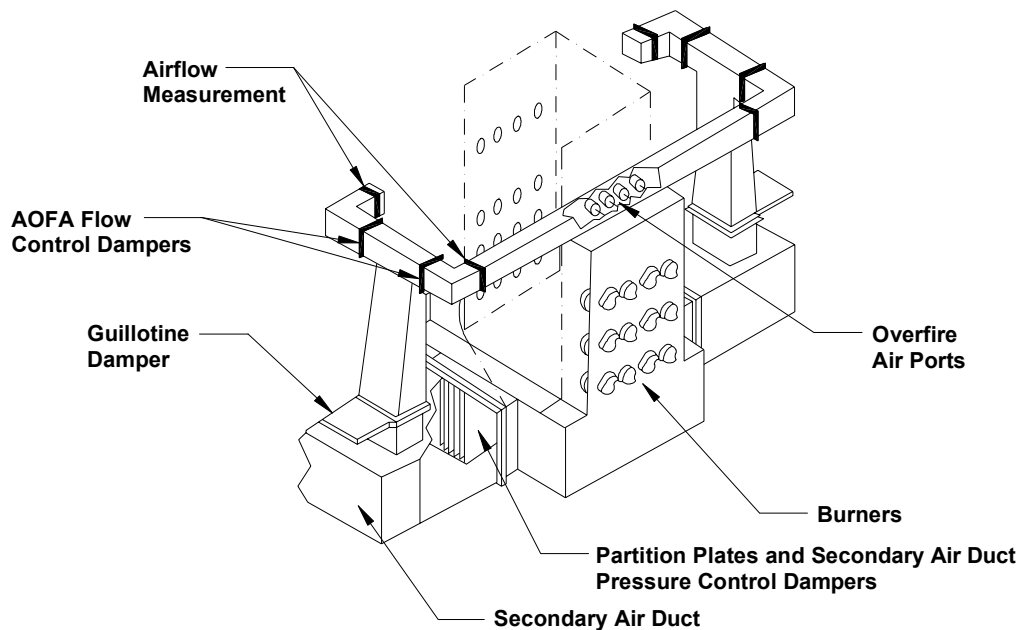

Figure 1. Advanced Overfire Air System

In conjunction with the installation of the AOFA system, FWEC also installed a furnace boundary air system to provide a passive means of maintaining an oxidizing atmosphere along the furnace sidewalls and in the furnace hopper zone, thus avoiding the corrosion that can result from deep staging. The boundary air system consists of air ports, hopper air slots, and sidewall air slots designed to divert a small amount of air from the burners to the lower furnace walls (Figure 2). The boundary air system does not supply additional air to the furnace nor does it increase the air requirement of the boiler. Thus, the combination of improved OFA mixing, deep staging, and boundary air constitutes the AOFA technology.

II.E.2 Low-NO_x Burners

LNBS are based on the same principles as OFAs, and are designed to achieve controlled fuel/air mixing on a localized, individual burner basis. Low-NO_x burner systems stage combustion by introducing air and coal into the furnace in a well controlled, reduced turbulence manner. To achieve this, the burner must regulate the initial fuel/air mixture, velocities, and turbulence to create a fuel-rich core with sufficient air to sustain combustion at a severely substoichiometric

air/fuel ratio. The burner must then control the rate at which the air necessary to complete combustion is mixed with the flame to maintain a deficiency of oxygen until the remaining combustibles fall below the peak NO_x producing temperature (around 2,800 °F). The final excess air can then be allowed to mix with the unburned products so that the combustion is completed at a lower temperature. The fuel-rich flame provides a sustained, oxygen-deficient region in which volatile nitrogen in the fuel can be evolved and reduced to molecular nitrogen, rather than being oxidized to NO_x. Thermal NO_x is also minimized, because the controlled air mixing extends into the cooler regions downstream of the flame.

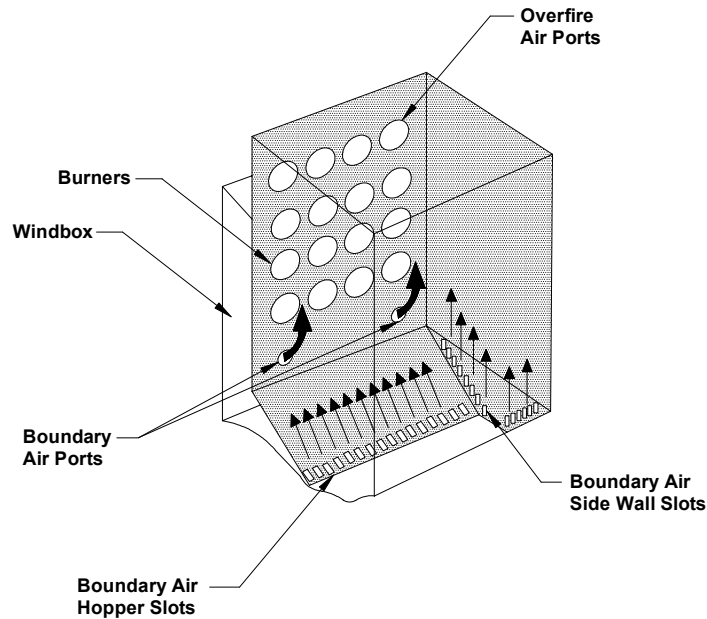

Figure 2. Boundary Air System

LNBS have been developed for both single and opposed wall-fired boilers. The LNBS installed as part of this project were FWEC Controlled Flow/Split Flame (CFSF) burners (Figure 3), in which the secondary air is divided between inner and outer flow cylinders. A movable sleeve damper regulates the total secondary air flow entering the burner. An adjustable outer register assembly divides the burner's secondary air into two concentric paths and imparts some swirl to the air streams. The secondary air that traverses the inner path flows across an adjustable inner register assembly that, by providing a variable pressure drop, apportions the flow between the inner and outer flow paths. The outer air flow enters the furnace axially, providing the remaining air necessary to complete combustion. The split flame coal nozzle segregates the coal/air mixture into four concentrated streams, each of which forms an individual flame when entering the furnace. This segregation minimizes mixing between the coal and the primary air, assisting in the staged combustion process.

Problems that can arise with LNBS are increased LOI (unburned carbon in the ash) and lower boiler efficiency. Increased LOI can result from a lower oxygen concentration in the flame zone and a shorter residence time after the introduction of AOFA. Higher CO concentrations can also occur, and temperature profiles in the furnace can be changed. All these effects can combine to reduce boiler efficiency. These problems can be mitigated by optimizing equipment settings and

careful unit control. To maximize effectiveness, settings should be adjusted continuously, which is difficult for an operator to accomplish, but may be possible through implementation of the proper computer controls.

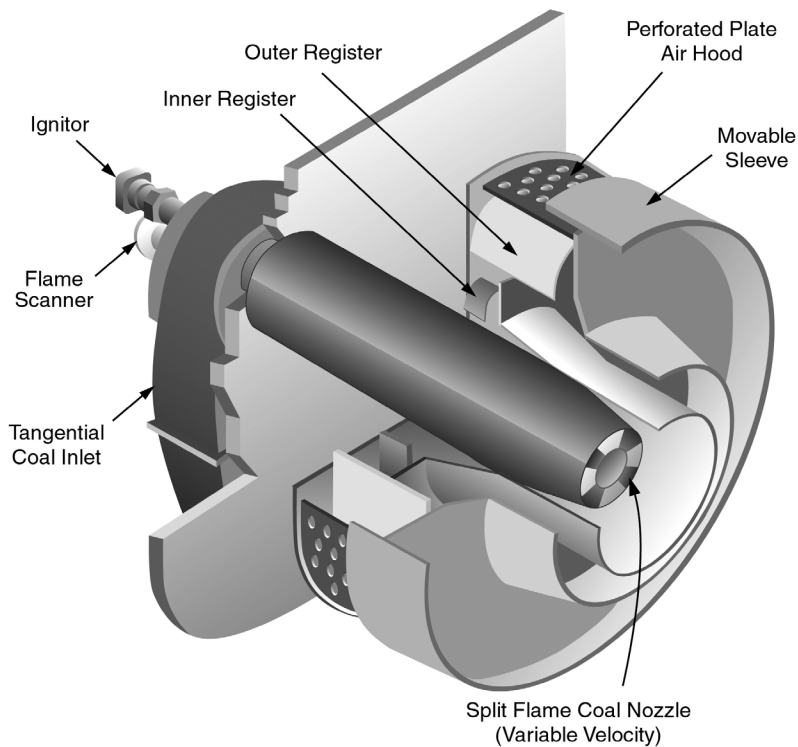

Figure 3. Controlled Flow/Split Flame Low NO_x Burner

II.E.3 Generic NO_x Control Intelligence System (GNOCIS)

GNOCIS is a software package designed to improve utility boiler efficiency and reduce NO_x emissions through careful control of operating parameters. GNOCIS can operate on units that burn gas, oil, or coal and is available for all combustion firing geometries. GNOCIS development was funded by a consortium consisting of EPRI, PowerGen, Southern Company, Radian International, the United Kingdom Department of Trade and Industry, and the U.S. DOE.

GNOCIS uses a neural network to model the combustion characteristics of a boiler. Neural networks can have many forms. In one of the more common forms, a neural network (computer code that models a system's responses) consists of three layers: an input layer, a hidden layer, and an output layer. The input layer receives signals from the monitored variables and transmits them to the hidden layer, which contains interconnected neurons for pattern recognition. After processing, signals are sent to the output layer, which outputs recommended settings for the control variables. Thus, a neural network is, in effect, a sophisticated curve fitting tool.

Neural networks can recognize patterns in input data, but before the network can associate a particular pattern with a corresponding plant state, it must be "trained." The training phase can be time consuming and usually involves feeding historical data to the program. However, once a network has been trained, it can respond very rapidly to new inputs. An advantage of a neural network is that, if any inputs are faulty, prediction capability degrades only gradually compared to most other modeling techniques.

In order for GNOCIS to function effectively, a properly designed and installed control system is essential. The control system installed at Plant Hammond was designed with the following features: unit master, fuel control, air flow control, furnace pressure control, feedwater control, steam temperature control, condensate control, auxiliary control, DCA heater level control, ash handling system, precipitator energy management system, precipitator fire protection, and burner management system. A Foxboro I/A Series distributed control system (DCS) was selected to provide the required controls.

As illustrated in Table 2, achieving combustion optimization became significantly more complex upon installation of LNBs plus AOFA, because there were many more variables to control. The two major optimization objectives are to reduce NO_x emissions and to improve efficiency. A major challenge of system optimization is that many variables affect these objectives in opposite ways. For example, increased excess air can decrease LOI, but increase NO_x. Increased LOI generally indicates poor combustion and, hence, reduced boiler efficiency. High LOI can also convert fly ash from a salable by-product into an undesirable waste material. Therefore, before optimization can be undertaken, a decision must be made on what constitutes optimum operation.

Table 2. Combustion Tuning Control Points

Before LNB+AOFA Retrofit	After LNB+AOFA Retrofit
Burners	
Sleeve registers (24)	Sleeve registers (24) Tip position (24) Inner registers (24) Outer registers (24)
Advanced Overfire Air	
	Can-in-can dampers (8) Flow control dampers (4)
Secondary Air	
Windbox balancing dampers	Windbox balancing dampers Boundary air
Mills	
Mill biasing (6)	Mill biasing (6)

At Plant Hammond, a constrained-nonlinear optimizing procedure was used to identify the best control variable set points for the plant. The recommended set points could then either be automatically implemented (closed loop operation) or set by the operators (open loop operation).

Prior to installation of the DCS and GNOCIS, another optimization program (ULTRAMAX) was tested. In general, the ULTRAMAX program succeeded in reducing NO_x emissions while maintaining excess oxygen, LOI, and CO within constraints. Overall, this initial study was successful, in that it provided further indication that online optimization techniques could be used to improve boiler performance. This success prompted the project participants to pursue installation of a DCS and closed-loop optimization in a fourth project phase.

Before being implemented at Plant Hammond, GNOCIS was tested at Alabama Power Company's Gaston Unit 4 (a 270-MWe wall-fired unit) and PowerGen's Kingsnorth Unit 1 (a

500-MWe tangentially fired unit). GNOCIS was initiated at Gaston in an open-loop configuration, which was later converted to closed-loop, and significantly improved performance. (LOI was reduced by 2.5 percent, and efficiency was improved by 0.4 percent.) At Kingsnorth, when set to minimize LOI, GNOCIS reduced LOI from 15 percent to 11 percent; when set to minimize NO_x, GNOCIS reduced NO_x by about 10 percent. These results provided the basis for installing GNOCIS at Plant Hammond.

Because of the success of GNOCIS in improving operation of the boiler, later, when the decision was reached to include steam turbine optimization as part of this project, it was decided to use GNOCIS as the core software in the steam turbine optimization package, using largely the same code base as for the boiler optimization. Differences between GNOCIS/boiler and GNOCIS/turbine are that GNOCIS/turbine is only open-loop and different process models were used. The curves used to train the model were based on Westinghouse supplied correction factors to turbine cycle heat rate for variations in throttle pressure and temperature and reheat temperature.

II.E.4 Total Plant Optimization Software

Because of the promising results from GNOCIS applied to the boiler at Hammond Unit 4, the decision was made to expand optimization studies to include optimization of the entire unit. Therefore, Phase 4 was extended to include a Phase 4C that involved the study and testing of several additional software packages. These included PowerGen's Intelligent Sootblowing System (ISBS), a real-time heat rate package, developed under contract by the Center of Electric Power at Tennessee Technological University, GNOCIS modified for steam turbine optimization, and EPRI's ESPert package. Results from these suboptimizers feed into a top-level optimizer, which was designed to optimize the entire Hammond Unit 4.

The overall objective of Phase 4C was to develop and demonstrate a quasi-steady state online optimization program for a power plant as a whole. Two approaches to this task are possible: (1) a single optimizer approach and (2) a hierarchical optimizer approach. In the first approach, a single model of the entire plant is required. Although on the surface this is a straightforward approach, it requires the development of a very complex model, which can be difficult to achieve with the necessary degree of accuracy. In the second approach, the plant is broken into a number of different units, each with its own optimizer. A top-level optimizer then receives input from the subsidiary optimizers, coordinates results, and outputs set points for the entire plant.

Although structurally more difficult to implement, this approach offers several advantages:

- The individual models are reduced in scope, making them easier to develop and maintain.
- There are fewer inputs to each model, reducing the likelihood of model failure due to incorrect input data.
- Each optimizer functions independently but with guidance (constraints, goals, etc.) imposed from the top-level optimizer; this partitioning provides greater flexibility and robustness.
- The failure of one subsidiary optimizer does not cause failure of the entire system; optimizers can be bypassed, if necessary, while causing only partial degradation of optimizer performance.
- Each unit optimizer can be selected to best match that unit's characteristics.
- Module testing is greatly facilitated, and adding new functionality is greatly simplified.

Because of these advantages, the hierarchical approach was chosen for this project. The three major efforts in the unit optimization task were development of a software framework to coordinate the optimizers, development of a global optimizer algorithm and software with the potential to greatly reduce the number of manipulated variables (PowerGen Optimizer), and inclusion of the Synengco SentinentSystem Global Optimizer software.

The problem of several suboptimizers giving conflicting control settings for the plant can only be solved by considering the overall plant objective function. An objective function is a weighted function of process variables, which is to be maximized or minimized. Whereas each sub-optimizer has its own objective function to minimize and only has knowledge of its own local restricted environment, the top-level optimizer must integrate the advice from all the sub-optimizers to produce an overall control strategy. Since the objective functions for the sub-optimizers involve different high level plant variables, a common objective must be defined to enable appropriate recommendations to be made. This objective should be to minimize total unit costs, and a unit cost objective function must be defined in terms of high level plant variables, such as NO_x, LOI, boiler efficiency, etc. It is important that costs be associated with high level plant variables; otherwise, it is not possible to fully define an overall plant objective function.

SCS took prototype, proof-of-concept software developed by PowerGen in Matlab code and implemented it at Plant Hammond. The major effort consisted of converting the code to C++, adapting the software to fit within the optimization framework, and adding enhancements. Another approach was to apply Synengco's SentinentSystem Global Optimizer. Synengco developed wrapper code for the existing boiler and turbine optimizers, so they could be incorporated into the SentinentSystem and provide a consistent framework for all the optimization models to contribute to a single objective function. The framework was also used to control the various models to achieve global optima. A hybrid optimizer was developed for Hammond Unit 4 to ensure that the global optimum was determined and that the program converged in an acceptable amount of time.

II.E.5 Intelligent Sootblowing System

Sootblowers are mechanical devices used for periodic online cleaning of gas-side boiler ash and slag deposits. They direct a cleaning medium—typically steam—through nozzles against the soot or ash accumulated on the heat transfer surfaces of boilers to remove the deposits and maintain heat transfer efficiency. Boiler sootblowing has an effect on NO_x emissions, boiler efficiency, steam temperature, and boiler tube life. (Tube failure is the leading cause of unplanned outages on coal-fired units.) Sootblowing is typically carried out either on a regular schedule or when plant operators detect a problem, such as low steam temperature.

The Hammond Unit 4 boiler has about 100 sootblowers. Steam is extracted at the boiler superheater at approximately 2,550 psig and 870 °F and reduced in pressure to 125 to 200 psig for sootblowing. During sootblowing, steam flow through the system is approximately 50,000 lb/hr. Sootblowing is controlled through a programmable logic controller interfaced to the DCS.

For this demonstration, PowerGen's Intelligent Sootblowing System (ISBS) was selected, primarily for its low cost and because it required no additional instrumentation. PowerGen developed ISBS at its Kingsnorth Station. Based on results at that site, it was decided to develop a fuzzy-rule base to generate recommendations. Prototype rules were developed that were subsequently translated into a PowerGen developed library. The fuzzy-rule-based system makes decisions based on the following criteria: reheat cleanliness factor, upper and lower spray flows,

backpass damper position, reheat temperature, and time since previous sootblowing.

II.E.6 Real-Time Heat Rate Package

To optimize power plant operations, it is necessary to know the heat rate (i.e., the quantity of heat required to generate one kWh of electricity). However, heat rate is difficult to calculate in real time, because no instrument continuously measures the heating value or composition of the coal being burned. The Center of Electric Power (CEP) at Tennessee Technological University was contracted to develop a real-time heat rate monitor. The initial version of this software was delivered in the summer of 2000 and the final version in March 2001. The software included two sets of calculations: the direct method and the indirect or continuous emissions monitors (CEMs) method. The program obtains process data from the data logger, consolidates and averages this data, performs calculations, and sends the results back to the data logger.

As stated above, to calculate heat rate in a straightforward manner requires the ultimate analysis of the coal, which is not available in real time. To overcome this problem, an alternative approach was developed that uses the flue gas analysis (available from CEMs) to estimate the coal analysis. However, sufficient information is not available to calculate the complete ultimate analysis (fuel moisture, ash, oxygen, and nitrogen contents cannot be calculated from available data, but measuring flue gas moisture and nitrogen contents would permit calculation of fuel moisture and oxygen levels). The calculation uses 59 inputs, consisting of 38 data inputs and 21 “constants,” such as relative humidity, LOI, CO in flue gas, and air heater leakage; 19 outputs are sent back to the data logger.

The program extracts data from the data logger and sends it to two subprograms. One subprogram calculates heat rate by the direct method using an assumed coal analysis. The other subprogram uses data from CEMs to calculate coal properties. The interface package provides the capability for initiation and parameter specification, error and status logging, viewing inputs and outputs, and setting options.

II.E.7 ESPert

ESP performance (stack opacity, particulate removal rate, and energy use) is greatly dependent on precipitator inlet conditions, which are a function of boiler operating conditions and, possibly, other post-combustion emission control technologies, such as SCR and SNCR. Given the dependence of ESP performance on upstream conditions and the ESP’s importance relative to environmental compliance, it was decided that the ESP should be included in the optimization study. EPRI’s ESPert program was chosen for this purpose. ESPert is a diagnostic and predictive model for ESPs, designed to evaluate and predict ESP performance and diagnose problems. ESPert interfaces with NWL Environmental Technologies’ Precipitator Control and Management System (PCAMS), a supervisory system for ESP remote control and data acquisition. PCAMS includes an energy management system targeted at reducing operating costs while maintaining opacity levels.

ESPERT is an ESP monitoring and troubleshooting program that continuously receives and interprets data from the ESP control system, CEMs, and boiler controls. The program continuously estimates ESP performance (including opacity), based on these inputs and diagnoses the probable causes of divergence between measured and predicted opacity. Although ESPert provides ESP performance estimates that can be compared with test results, its primary intended use was as an aid for plant staff to diagnose ESP operation and mechanical and

electrical problems. For this project, a more important feature of ESPert is that it allows “what if” analyses, where operational scenarios may be tested before actual implementation in the plant.

II.F Project Objectives and Statement of Work

The primary objective of the demonstration was to determine the long-term effects on NO_x emissions and boiler performance of commercially available, low-NO_x combustion technologies for wall-fired furnaces. The target for the project was to achieve at least 50 percent NO_x reduction using combustion modifications (LNBS plus AOFA). The original specific objectives of the project were:

- To demonstrate in a logical stepwise fashion the short-term NO_x reduction capabilities of the following advanced low-NO_x combustion technologies: AOFA, LNBS, and LNBS plus AOFA.
- To determine the dynamic, long-term emissions characteristics of each of these NO_x reduction methods using statistical techniques.
- To evaluate the progressive cost effectiveness (dollars per ton of NO_x removed) of the low-NO_x combustion techniques tested.
- To determine the effect on other combustion parameters (CO production, carbon carryover, particulate characteristics) of applying these NO_x reduction methods.

The objective of Phase 4, which was added later, was to evaluate advanced digital control and optimization techniques applied to individual components and to the entire unit to achieve (1) further reduction of NO_x emissions, (2) mitigation of adverse impacts of LNBS and AOFA, and (3) improvement of boiler efficiency.

III Technical and Environmental Assessment

III.A Technical Results

This section discusses the results of the AOFA, LNBS, and optimization test programs run on Plant Hammond Unit 4. Key features of Hammond Unit 4 that need to be considered when evaluating the applicability of the results from this project to other units are:

- A high heat release rate
- A relatively short distance between the top burner and the furnace outlet (55 ft)
- Marginal ESP capacity during Phases 1, 2, 3A, and 3B of the test program
- Low-to-medium reactivity Eastern bituminous coal fuel

III.A.1 Description of the Test Program

The underlying premise for the testing program was that only long-term tests can adequately characterize the emissions from a utility boiler. Therefore, the focus of the test effort was long-term evaluation, using short-term testing only to establish trends to help translate results from this project to other similar boilers. Phases 2, 3A, and 3B involved three distinct testing periods: short-term characterization, long-term characterization, and short-term verification. Some HAPs tests were also conducted, but these were not part of the project and are not covered in this report.

Short-term testing consisted of a series of diagnostic tests to establish the trend of NO_x emissions as a function of a range of variables and the influence of the operating mode on combustion performance. Short-term tests were conducted under controlled conditions with the unit not on automatic load dispatch so that steady-state boiler conditions would be maintained. Diagnostic testing was used to establish the emission trends of the unit over the range of operating conditions normally encountered. Variables were kept within their normal ranges with reasonable excursions about these conditions, except for excess oxygen, which was varied well above and below normal levels. The primary parameters that were varied were excess oxygen, mill pattern, and mill bias. A diagnostic test typically required 1 to 2 hours to change conditions, and the unit was then held steady for 1 to 3 hours.

Diagnostic tests were followed by performance testing to fully characterize the impacts of the technologies being evaluated. Performance testing was conducted at specified loads and conditions based on suggestions by plant personnel, the technology vendor, and the results of the diagnostic tests. Generally, performance tests were conducted during a 10 to 12-hour period and included collection of the following data:

- NO_x, SO₂, CO, and excess O₂ concentrations at the economizer outlet and the stack
- Resistivity, total particulate emissions, and LOI of the fly ash
- Primary, secondary, and AOFA air flow rates
- Coal distribution to the mills
- Coal properties (HHV, nitrogen content, and fineness)
- Boiler performance parameters (economizer outlet temperature, steam flows, etc.)

Long-term characterization testing, involving 50 to 80 continuous days of operation, established the dynamic response of NO_x emissions to all of the operating parameters. The specific

objectives of the long-term tests were:

- To determine load and NO_x emissions as a function of time
- To determine NO_x emissions as a function of excess air and mill pattern
- To determine 30-day rolling average NO_x emissions
- To determine the achievable NO_x emissions level
- To compare long-term and short-term results

Short-term verification testing followed long-term testing to ensure that no changes that affected NO_x emissions levels had occurred during the long-term test period. Short-term and long-term baseline testing was conducted in an “as-found” condition from November 1989 through March 1990. Table 3 presents the schedule for testing during Phases 2, 3A, and 3B.

Table 3. Testing Schedule for Phases 2, 3A, and 3B

	Short-Term Characterization Testing		Long-Term Performance Testing	
	Start	End	Start	End
Phase 2	May 23, 1990	August 16, 1990	October 14, 1990	March 8, 1991
Phase 3A	July 9, 1991	January 15, 1992	August 7, 1991 ^a	December 19, 1991 ^a
Phase 3B	May 6, 1993	August 26, 1993	May 11, 1993	August 13, 1993
Phase 4A	August 5, 1994 November 2, 1994	August 8, 1994 November 18, 1994	July 12, 1994	November 17, 1994
Phase 4B			February 1996	March 2003

^a Some testing time was lost during this period due to unit outages.

HAPs testing (Southern Company Services, 1993, 1995) at the stack was conducted in the AOFA and LNBS plus AOFA configurations. These tests were intended to quantify emissions of targeted air toxics, determine the efficiency with which they are removed by the ESP, and determine their distribution among the various plant discharge streams.

Phase 4A evaluated advanced digital control and Phase 4B evaluated optimization techniques as applied to the reduction of NO_x emissions, the improvement of boiler efficiency, and the mitigation of adverse impacts of LNBS and AOFA (increased LOI and decreased efficiency). The first step in Phase 4B was preliminary modeling based on about 12,000 data points collected during Phase 3B. Although models can be statistical or based on fundamental principles, the complexity of combustion systems and the difficulty in determining the values of some parameters renders models based on fundamentals generally infeasible. A linear statistical model, which was tried first, proved unsatisfactory and was replaced by a nonlinear model, which provided much better results. The success of this preliminary modeling effort provided the incentive for implementing GNOCIS, and the success of GNOCIS created the impetus for testing more extensive optimization in Phase 4C, which tested programs for optimizing the boiler, sootblowers, ESP, steam turbine, and entire unit.

III.A.2 Discussion of Results from Phases 1, 2, 3A, and 3B

III.A.2.a Phase 1 - Baseline Testing

The most important criteria for evaluating performance in this project are NO_x and CO emissions, excess oxygen, LOI of the ash, coal fineness, furnace slagging, backpass fouling, and

performance of the ESP. Figure 4 shows the baseline (pre-retrofit) results. NO_x emissions at a 480-MWe load before installation of the low-NO_x technologies ranged from 1.1 to 1.45 lb/10⁶ Btu (750 to 1,000 ppm) with excess oxygen at 2 to 5 percent, measured at the economizer outlet. The average full-load long-term NO_x emissions rate, with no attempt to optimize the system, was 1.24 lb/10⁶ Btu at an average oxygen level of 2.6 percent. NO_x emissions decreased slightly with decreasing load. CO emissions were generally below 100 ppm over the load range.

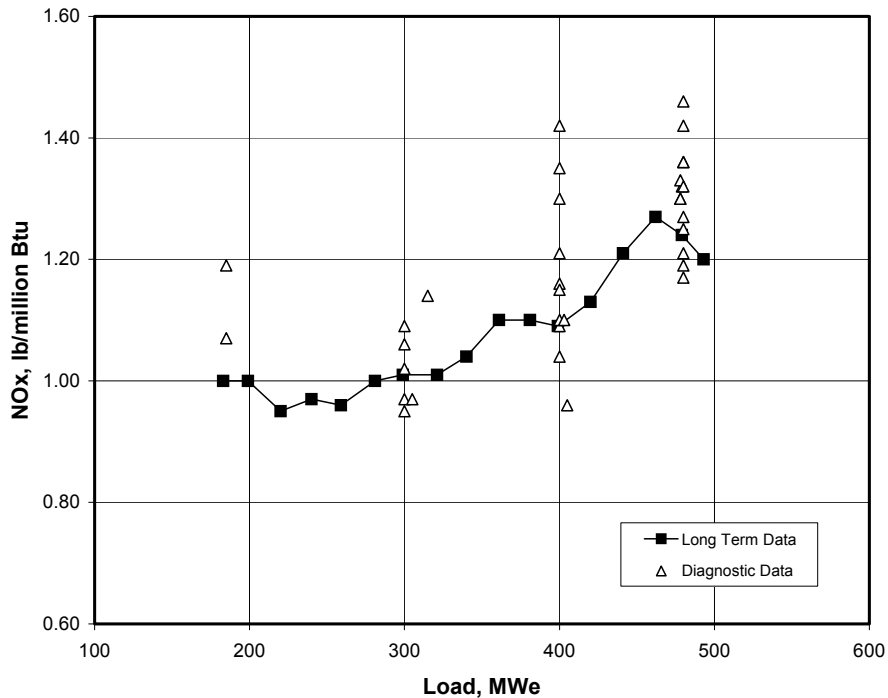

Figure 4. Baseline NO_x Emissions

Excess oxygen (measured at the economizer outlet) at full load was in the range of 2 to 5 percent with an average of 2.6 percent. The lower limit was established to keep CO emissions from increasing, while the upper limit resulted from ESP capacity limitations. LOI at full load was 5 percent with average coal fineness of 2.8 percent on 50 mesh and 63 percent through 200 mesh. This fineness is somewhat poorer than typically recommended for LNBS (less than 1.5 percent on 50 mesh and greater than 70 percent through 200 mesh) by equipment suppliers.

Significant air and coal flow imbalances were detected. Oxygen concentration varied from 2 to 5 percent from the front to the rear wall, and coal flow varied by up to 11 percent from one mill to another. The furnace was found to experience moderate-to-high slagging, which contributed to high furnace temperatures. Superheater outlet temperature was between 900 and 1,000 °F, while the reheat temperature was below 1,000 °F (950 to 980 °F in the 250 to 420-MWe load range).

III.A.2.b Phase 2 - AOFA Testing

Phase 2 began with 82 diagnostic tests and ended with 15 verification tests to determine if significant changes had taken place during long-term testing. Operating conditions that were varied included excess oxygen, mill pattern, OFA setting, and system load. Because the unit had historically operated at loads of 400 MWe or above, more extensive testing was performed at higher loads. In addition to the diagnostic tests, nine performance tests were conducted, as

shown in Table 4. During each test, coal rate was kept as constant as possible, with load being allowed to vary in response to coal properties.

Table 4. Phase 2 Performance Tests Summary

Test No.	Load, MWe	O ₂ , percent	Mills Out of Service	OFA Damper Setting, percent	NO _x , lb/10 ⁶ Btu	Particulate Loading, gr/dscf ^b	LOI, percent
37	480	3.0	None	75	0.73	2.74	10.8
38	485	4.0	None	75	0.83	^a	^a
39	400	4.1	E	50	0.73	2.86	10.2
40	405	3.7	E	50	0.75	^a	^a
41	298	5.3	E	50	0.87	1.81	7.1
42	300	5.4	E	50	0.83	^a	7.1
43	487	4.0	None	50	0.95	2.66	9.6
44	487	3.7	None	50	0.90	2.66	9.6
45	489	3.8	None	1	1.23	2.82	5.4

^a No measurement

^b Grains per dry standard cubic foot

At an AOFA damper position of 50 percent (the FWEC recommended set point), overfire air amounted to 20 to 25 percent of the total air (primary air was 20 to 30 percent, and secondary air was 50 percent). A major conclusion from the performance and verification testing was that the presence of AOFA did not significantly affect either the loading or composition of particulates, except for some high LOI values. Neither OFA damper position nor load had a significant effect on SO₃ concentration.

Long-term testing of AOFA consisted of continuous measurement of operating parameters while the unit was under normal load dispatch. As shown in Figure 5, NO_x emission rate was almost independent of system load, averaging approximately 0.9 lb/10⁶ Btu. This is in contrast to the baseline testing, which showed an increasing NO_x level with increasing load. Figure 6 shows that, as expected, excess oxygen decreased as load increased, since a similar curve is used by the control system to set the excess oxygen level. SO_x level was unaffected by system load. This is not unusual, since SO_x is not generally affected by combustion conditions. CO levels averaged less than 15 ppm for all load levels.

Figure 7, which presents long-term NO_x level plotted as a 30-day rolling average, shows that with AOFA NO_x averaged 0.92 lb/10⁶ Btu, almost independent of system load, for the duration of the test. Since emissions can vary with system parameters, somewhat different results might have been recorded had the unit operated under significantly different conditions.

III.A.2.c Phase 3A - LNB Testing

Phase 3A short-term testing consisted of 52 diagnostic tests plus 40 special LOI tests. All major boiler components and ancillary equipment were in their normal operating condition as configured by FWEC. The main AOFA guillotine and port dampers were left open, but the AOFA flow control dampers were nominally closed, with only sufficient flow permitted to provide some cooling for the AOFA ports and dampers to prevent heat damage. Figure 8 shows NO_x emissions as a function of excess oxygen for a load of 480 MWe.

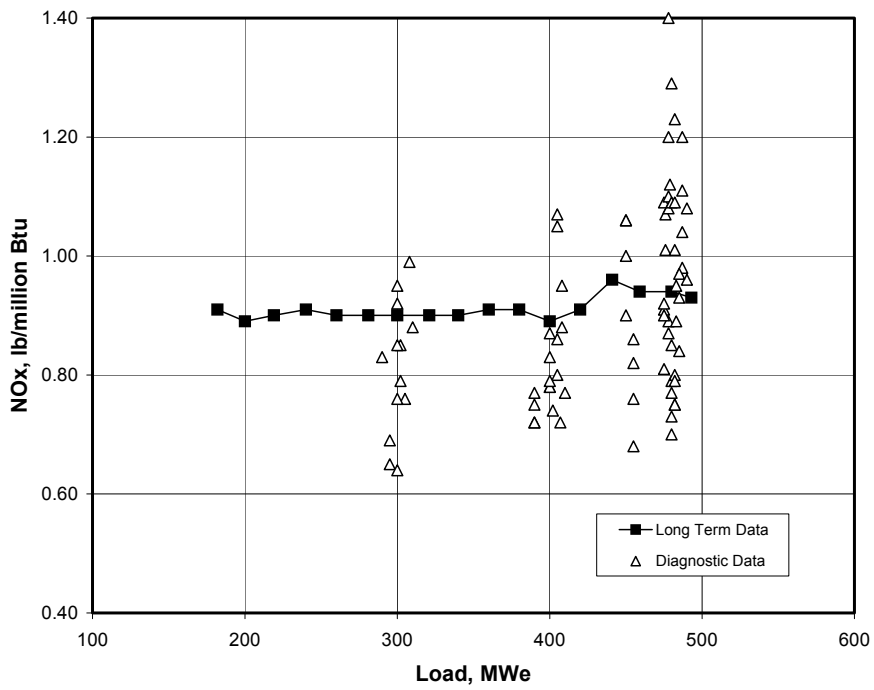

Figure 5. NO_x Emissions with only AOFA Implemented

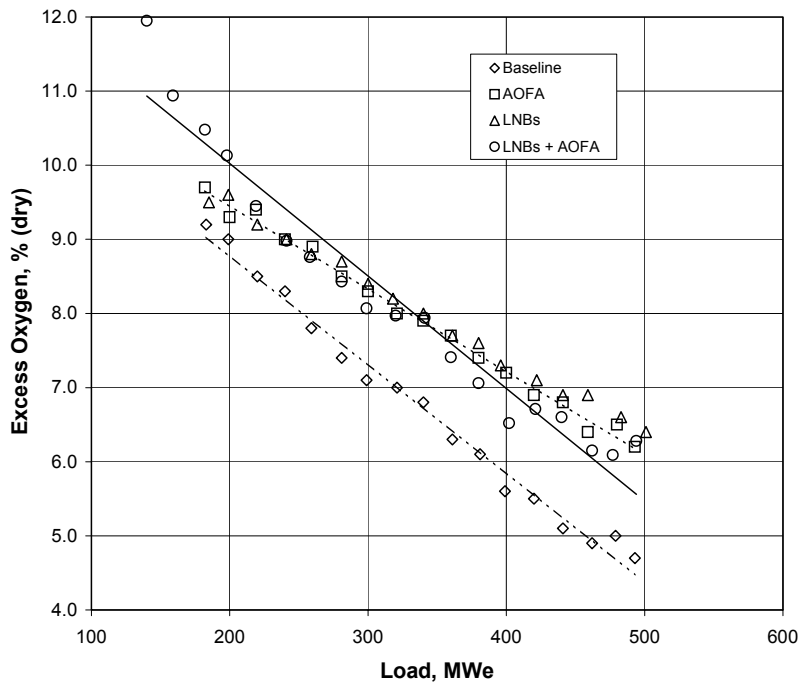

Figure 6. Excess Oxygen as a Function of Load

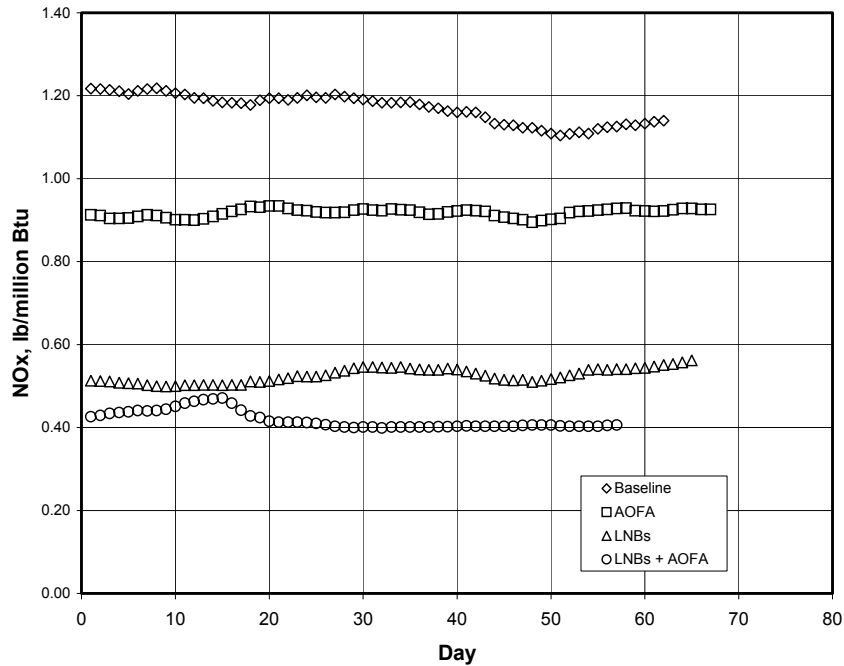

Figure 7. 30 Day Rolling Average NO_x Emissions

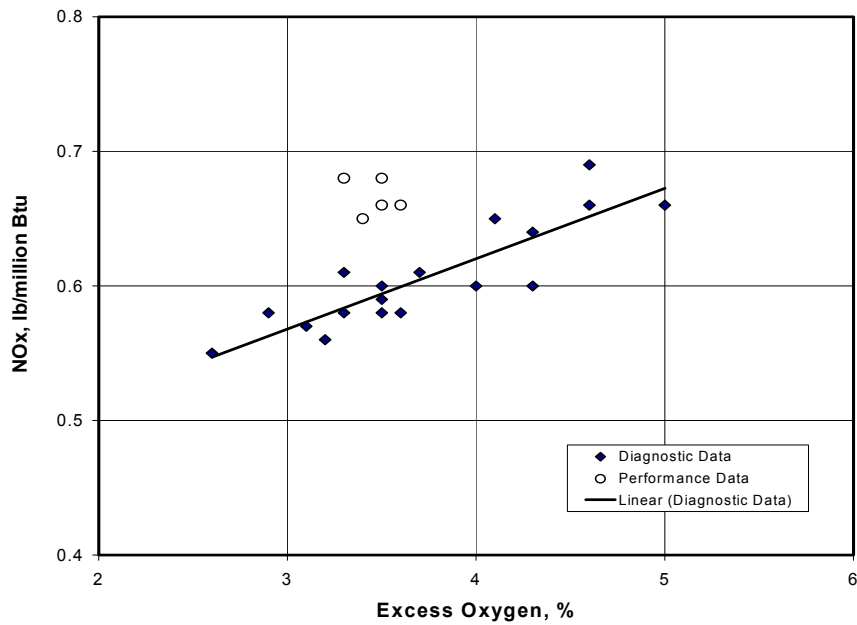

Figure 8. NO_x Emissions as a Function of Excess Oxygen at a Load of 480 MWe

Following the Phase 3A diagnostic tests, nine performance tests were conducted, as shown in Table 5. During each test, coal rate was kept as constant as possible, with load being allowed to vary with coal properties. Table 5 shows that NO_x emissions increased significantly with increasing load, ranging from approximately 0.48 lb/10⁶ Btu at 300 MWe to about 0.65 lb/10⁶ Btu at 480 MWe. These results are consistent with the results of the diagnostic testing.

Ash resistivity—an important factor affecting ESP performance—is strongly attenuated by surface films of sulfuric acid produced by the adsorption of SO₃ and water vapor from the flue gas. There was a slight increase in SO₃ concentration with increasing temperature. The ratio of SO₃/SO₂ did not remain constant during the tests, but varied from a low of 0.004 to a high of 0.0078.

Table 5. Phase 3A Performance Tests Summary

Load, MWe	O ₂ , %	Mills Out of Service	NO _x , lb/10 ⁶ Btu	Particulate Loading, gr/dscf ^b	LOI, %
470	4.0	None	0.62	3.39	7.6
475	3.8	None	0.63	^a	^a
475	3.5	None	0.67	3.17	7.8
469	3.5	None	0.67	^a	^a
477	3.4	None	0.65	3.26	8.6
389	4.1	None	0.55	2.83	5.4
404	3.7	None	0.56	^a	^a
299	4.3	E	0.47	2.90	5.8
298	4.5	E	0.48	^a	^a

^a No measurement

^b Grains per dry standard cubic foot

Prior to the special LOI testing, tests were performed to evaluate the condition of the coal and primary air supply systems. Results showed that (1) the newer B&W MPS mills (A, C, E, and F) provided excellent fineness (more than 70 percent through 200 mesh and less than 0.23 percent larger than 50 mesh), significantly better than the older FWEC MB mills (B and D) with less than 70 percent through 200 mesh and more than 2 percent on 50 mesh; (2) there was considerable variation in the coal flow from pipe to pipe for all the mills, varying from ~8 percent from the mean for the B mill to ~30 percent for the D mill; and (3) the D mill had a substantially lower coal flow and higher air/fuel ratio than the other mills.

A special series of 40 tests to evaluate the effect of various burner and boiler parameters on fly ash LOI was conducted from October 15 to 28, 1992. The testing consisted of (1) measurement of the coal and primary air flow rates through each mill at a nominal load of 450 MWe, as well as the coal and primary air distributions and particle size range in each individual coal pipe; (2) fly ash sampling at the precipitator inlet; and (3) measurement of gaseous emissions. The variables tested and their ranges are shown in Table 6.

Increasing excess air significantly reduced LOI but increased NO_x. Over the range tested, adjustments to the inner and outer registers (Figure 3 on page 17 shows the location of these registers) had only a minimal effect on LOI and NO_x. LOI increased about 35 percent in going from the lower mills having a positive bias to the upper mills having a positive bias, while NO_x decreased about 10 percent for the same change. Adjusting the coal pipe tip position had a small effect, with LOI decreasing and NO_x increasing as the coal pipes were withdrawn. In general, these tests showed that parameter changes that improve LOI have the opposite effect on NO_x.

Table 6. Parameters Tested in Special LOI Tests

Parameter	Nominal Value	Range Tested	
		Low	High
Excess Air	4%	2.8%	5.0%
Inner Register	15%	Nominal	Nominal + 40%
Outer Register	60%	-20% of Nominal	+20% of Nominal
Sliding Tip	+4 inches	+2 inches	+4 inches
Mill Bias	No bias	Upper Mills +10% Lower Mills -10%	Upper Mills -10% Lower Mills +10%

During long-term testing, the unit was operated under normal load dispatch. The unit typically operated at base load for 16 hours a day—considerably lower than during baseline and AOFA testing. Oxygen concentration decreased as system load increased, as discussed previously (see Figure 6 on page 26). NO_x emissions exhibited an increased dependency on load compared to preceding phases, with NO_x level (Figure 9) being lowest at mid-loads (250 to 300 MWe) and increasing at both lower and higher loads. Figure 9 also compares results from the short-term and long-term tests. In general, the short-term NO_x data are within the ±95 percentile limits of the long-term data. Based on the data collected during the long-term test, the achievable NO_x limit was estimated to be 0.58 to 0.64 lb/10⁶ Btu on a 30-day rolling average basis and 0.54 to 0.55 lb/10⁶ Btu on an annual basis. The rate of SO_x production remained essentially constant over the load range, and CO emissions were low (below 20 ppm) over the entire load range.

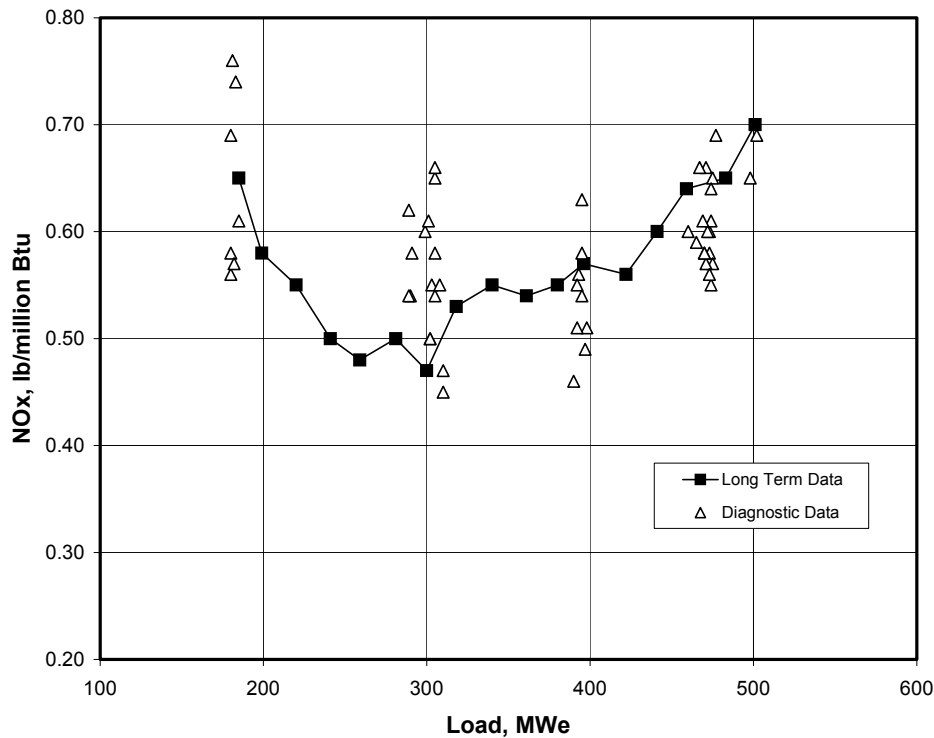

Figure 9. NO_x Emissions with only LNBS Implemented

III.A.2.d Phase 3B - LNBS Plus AOFA Testing

Due to scheduling problems, Phase 3B was split into two periods with a furnace outage in between. Because the two new mills (B and E) to be installed during the outage would cause some change in operations, it was important to have a test period before the spring 1992 outage. Therefore, abbreviated diagnostic testing was conducted from February 18 to 25, 1992, prior to the outage.

Results from these tests indicated full-load NO_x emissions of about 0.55 lb/10⁶ Btu and fly ash LOI of about 11 percent. Full-load, long-term NO_x values for the baseline, AOFA, and LNBS test phases were approximately 1.24, 0.94, and 0.65 lb/10⁶ Btu, respectively. Secondary air, overfire air, and primary air accounted for 66, 17, and 16 percent respectively, of total combustion air at full-load. This is somewhat different from results obtained during Phase 2 testing, discussed on page 24.

The effect of OFA damper position on NO_x emissions was less for the AOFA plus LNBS combination than for AOFA alone. For AOFA alone with damper positions between 0 and 55 percent, NO_x decreased at a rate of 0.0035 lb/10⁶ Btu/percent damper opening. For the AOFA plus LNBS configuration, sensitivity was only 0.0014 lb/10⁶ Btu/percent damper opening, less than half as sensitive. This is not unexpected, since the LNBS have already reduced NO_x production, so that the effect of the AOFA is reduced. Six performance tests were conducted, as listed in Table 7.

Table 7. Phase 3B Performance Test Summary

Load, MWe	O ₂ , %	Mills Out of Service	NO _x , lb/10 ⁶ Btu	Particulate Loading, gr/dscf ^b	LOI, %
470	3.9	None	0.43	2.98	8.0
474	3.9	None	0.42	^a	^a
301	4.1	B	0.32	2.92	5.7
300	4.3	B	0.32	^a	^a
400	4.5	B	0.42	2.96	6.4
401	4.6	B	0.42	^a	^a

^a No measurement

^b Grains per dry standard cubic foot

During the long-term tests, NO_x level was in the range of 0.32 to 0.58 lb/10⁶ Btu. At about 20 days into the test, there was an unexplained spike of high NO_x values, but for the rest of the time the data was typically in the range of 0.35 to 0.45 lb/10⁶ Btu. Figure 10 shows a plot of NO_x versus system load for Phase 3B. NO_x remained almost constant at 0.40 lb/10⁶ Btu over the load range of 200 to 500 MWe. At lower loads, OFA was essentially closed, and NO_x increased to approximately 0.48 lb/10⁶ Btu at 140 MWe. Based on the data collected during the long-term test, the estimated achievable NO_x limit was 0.51 lb/10⁶ Btu on a 30-day rolling average basis and 0.42 lb/10⁶ Btu on an annual basis. Figure 10 also compares results from the short-term and long-term tests in Phase 3B. In general, the short-term data are within the ±95 percentile limits of the long-term data.

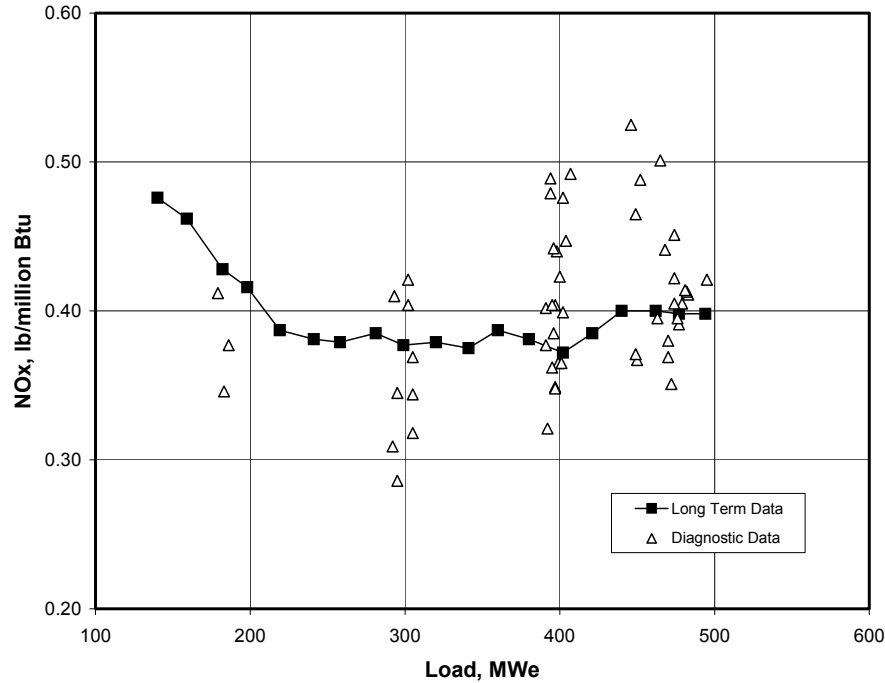

Figure 10. NO_x Emissions with LNBS plus AOFA Implemented

Excess oxygen downstream of the air heater showed the same trend as earlier phases (decreasing oxygen with increasing load, as shown in Figure 6). Sulfur oxides also followed a pattern similar to earlier phases, remaining essentially constant with system load. CO was less than 50 ppm for loads up to 250 MWe, but increased considerably at higher loads, as shown in Figure 13. Results from a short series of verification tests following the long-term testing showed that NO_x emissions were comparable to the earlier levels, indicating that no fundamental changes occurred during the long-term tests.

III.A.3 Comparison of Phases 2, 3A, and 3B Results to Baseline

III.A.3.a NO_x Emissions

Figure 11 compares the average NO_x emissions for the baseline, AOFA, LNBS, and LNBS plus AOFA configurations. Full-load NO_x emissions were reduced from approximately 1.2 lb/10⁶ Btu at baseline conditions to 0.40 lb/10⁶ Btu for LNBS plus AOFA. Figure 12 shows NO_x reduction as a function of load. Full-load reductions were about 20, 50, and 65 percent respectively for AOFA, LNBS, and LNBS plus AOFA. Over the entire range of tests, it was found that the effect of increasing excess oxygen by 1 percent was to increase NO_x production by about 0.1 lb/10⁶ Btu. (Figure 7 28 shows NO_x levels on a 30-day rolling average basis.)

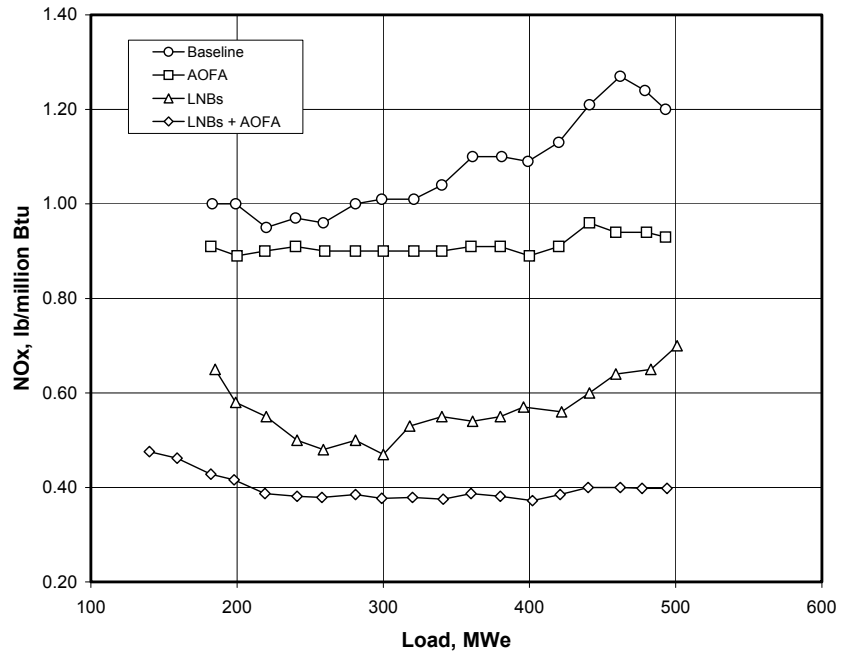

Figure 11. NO_x Emissions as a Function of Load

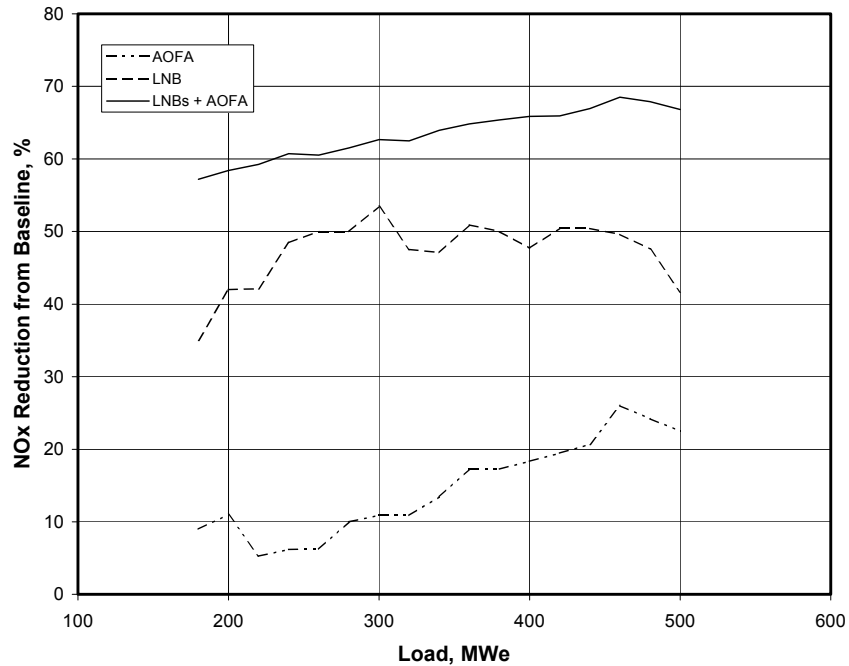

Figure 12. NO_x Reductions from Baseline as a Function of Load

III.A.3.b LOI Levels

Table 8 presents the full-load LOI results observed during the test program. Similar increases in LOI were obtained at all load levels. These increases occurred despite the replacement of four of the six coal mills during the course of the test program and the resultant improvement of coal fineness.

Table 8. Full-Load LOI Levels

Test Phase	Baseline	AOFA	LNBS	LNBS plus AOFA
Performance Test Stack O ₂ , percent	7.5	6.3	6.4	6.6
Performance Test LOI, percent	5.2	10.2	8.6	8.0
Increase Over Baseline, percent	----	96	65	54
Long-Term Stack O ₂ , percent	5.0	6.5	6.6	6.1
Long-Term LOI, percent ^a	7.1	10.1	8.2	8.4
Increase Over Baseline, percent	----	42	16	18

^a LOI corrected to stack O₂ level on the basis of 0.75 percent LOI per percent change in excess O₂

III.A.3.c CO Emissions

Figure 13 presents CO levels as a function of system load. While CO levels for the AOFA and LNBS phases were lower than those observed during baseline, CO levels for LNBS plus AOFA were higher than baseline at most load levels.

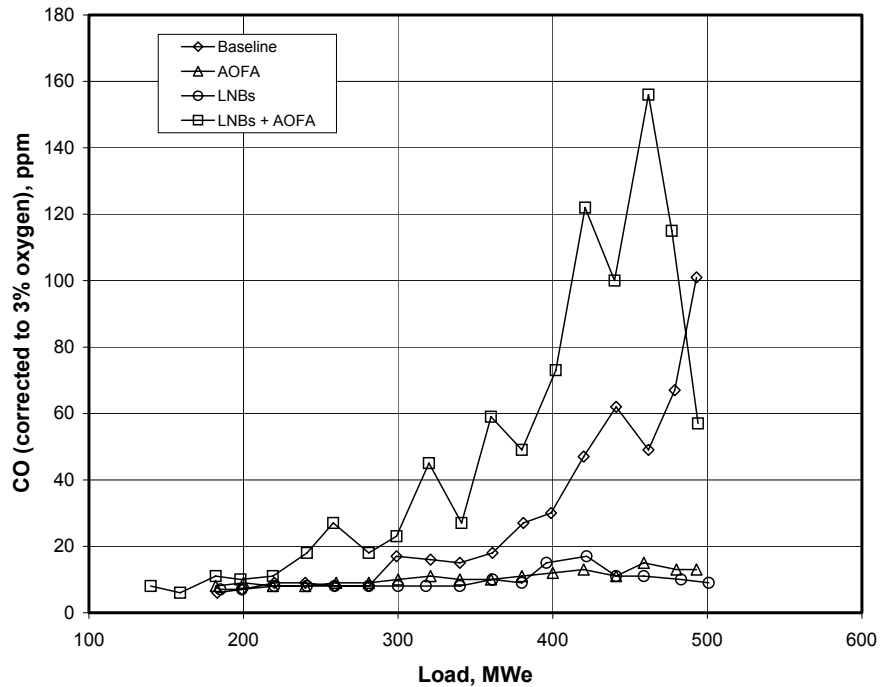

Figure 13. CO Emissions as a Function of Load

III.A.3.d Excess Oxygen

The long-term stack oxygen levels for the baseline, AOFA, LNBS, and LNBS plus AOFA phases are shown in Figure 6 on page 26. The baseline stack oxygen level is substantially lower than observed for the subsequent phases. The increase in the stack oxygen level could be the result of increased combustion air requirements or backpass, air heater, or precipitator air infiltration. Because of the latter, stack oxygen is not always a good indicator of the combustion air requirements for low-NO_x combustion technology.

III.A.3.e Boiler Efficiency and Unit Heat Rate

The impacts discussed above affect boiler efficiency and turbine heat rate, which in turn affect the unit's net heat rate. Table 9 shows the effects that were measured in the short and long-term tests at full-load.

III.A.3.f Summary of Effects

Both adverse and beneficial impacts on Plant Hammond Unit 4 operation were experienced after the retrofit of AOFA and LNBS. Adverse effects included: (1) higher excess oxygen, (2) higher LOI, and (3) increased dust loading and gas flow into the marginally sized ESP, which resulted in temporarily derating the unit. (This latter effect should not occur in units with adequately sized ESPs.) The main beneficial effect, in addition to NO_x reduction, was a significant reduction in waterwall slagging. Table 10 summarizes the performance impacts from the installation of LNBS and AOFA.

Table 9. Impact on Full-Load (480 MWe) Unit Heat Rate

Configuration	AOFA	LNBS	LNBS plus AOFA
Performance Tests	Btu/kWh		
Baseline Heat Rate	10,000	10,000	10,000
Additional Loss in Dry Flue Gas	-4	-11	47
Additional Loss in Unburned Carbon	60	45	30
Superheat Penalty	-2	-4	-23
Reheat Penalty	-4	-4	-15
Unit Heat Rate	10,050	10,026	10,039
Boiler Efficiency, percent ^a	89.5	89.7	89.3
Turbine Cycle Heat Rate ^b	8994	8992	8961
Long-Term Tests	Btu/kWh		
Baseline Heat Rate	10,000	10,000	10,000
Additional Loss in Dry Flue Gas	49	63	128
Additional Loss in Unburned Carbon	37	11	18
Superheat Penalty	4	-7	-20
Reheat Penalty	-5	-18	-21
Unit Heat Rate	10,085	10,049	10,105
Boiler Efficiency, percent ^a	89.2	89.3	88.7
Turbine Cycle Heat Rate ^b	8999	8975	8960

^a Baseline efficiency = 90 percent

^b Baseline turbine cycle heat rate = 9,000 Btu/kWh

Table 10. Impacts of Low-NO_x Technologies on Boiler Performance

Configuration	Baseline	AOFA	LNBS	LNBS plus AOFA
Average Excess Oxygen, %	2.6	2.6	4.1	3.8
LOI, %	5	10	8	8
Slagging	Moderate to high	Slightly reduced	Substantially reduced	Substantially reduced
Steam Superheat	----	Improved	Improved	Improved
Reheat Temperature	----	Improved at higher loads	Improved at higher loads	Improved at higher loads
ESP Performance	Marginal	Marginal	Derating to 300 MWe ^a	Derating to 450 MWe ^b

^a Derating to 300 MWe due to increased dust loading; load reestablished with NH₃ injection

^b Derating to 450 MWe even with use of NH₃ injection system

III.A.4 Phase 4A—DCS Testing

Table 11 shows a summary of the results of the Phase 4A performance tests. Coal fineness during these tests was at least 73 percent through 200 mesh and only 0.1 percent on 50 mesh. Although the shape of the curve of NO_x versus load is slightly different, average NO_x emissions, shown in Figure 14, were comparable to those observed during Phase 3B. Results for LOI (also shown in Figure 14) were comparable to Phase 3B results, even though improved performance might have been expected as a result of the new coal mills.

Table 11. Phase 4A Performance Test Summary

Load, MWe	O ₂ , %	Mills Out of Service	NO _x , lb/10 ⁶ Btu	LOI, %
400	3.9	B	0.38	8.4
300	4.8	B, E	0.34	8.1
180	5.3	B, D, E	0.33	3.6
520	3.6	None	0.43	8.2
520	3.5	None	0.45	8.1

Figure 15 shows NO_x emissions during the long-term test. The excess oxygen downstream of the air heater shows the same trend as for the other phases of the program—increasing excess oxygen with decreasing load. Contrary to trends in prior phases, NO_x tended to increase with increasing load. CO emissions remained low, with average levels of about 15 ppm. SO_x emissions were independent of load.

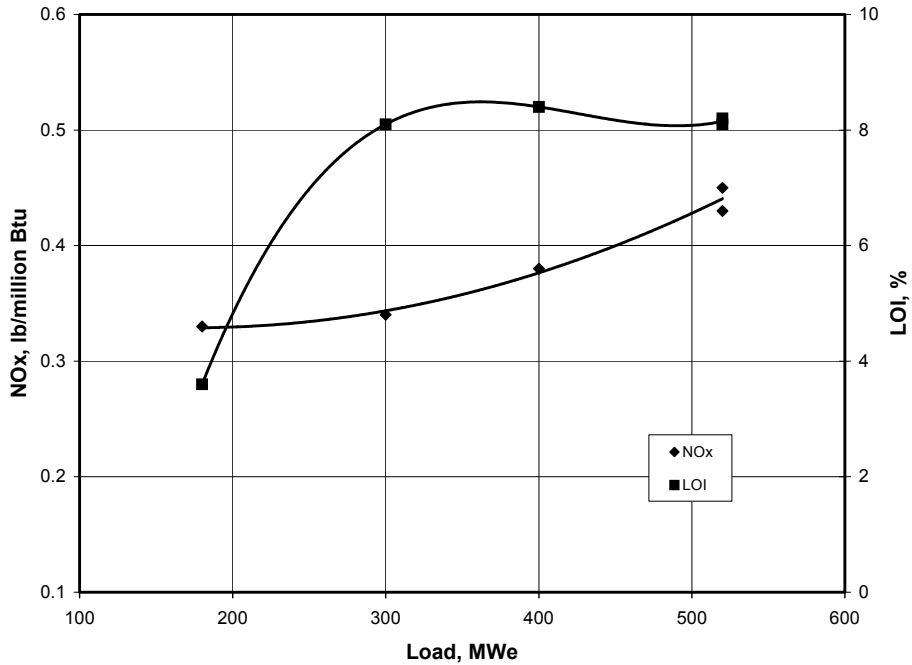

Figure 14. NO_x Emissions and LOI with DCS Installed

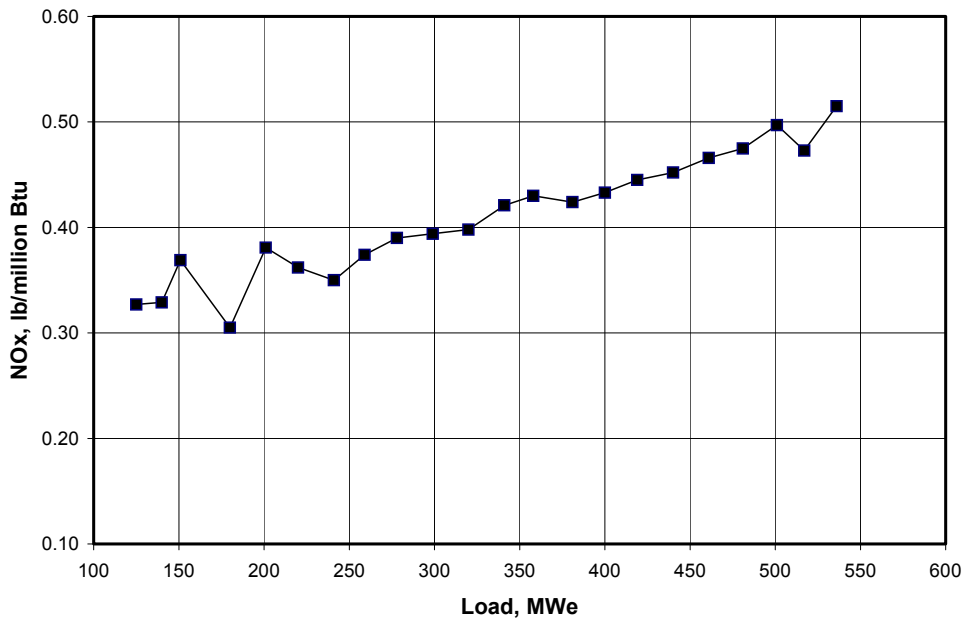

Figure 15. Long-Term NO_x Emissions with DCS Installed

With a few exceptions, performance during Phase 4A was similar to performance during Phase 3B, indicating that installation of the DCS did not have a major effect on unit behavior. However, the importance of this work was that it established a baseline for evaluating the performance of the GNOCIS software package, which was subsequently installed on Unit 4.

III.A.5 Phase 4B—GNOCIS Testing

GNOCIS became operational in open-loop during the first quarter of 1996 and in closed-loop in the second quarter of 1996. Preliminary testing of GNOCIS at Plant Hammond, which began in February 1996, indicated that some changes to the initial model were desirable. A revised model (substitution of AOFA damper position for AOFA flow rates and a reduction in the number of input variables) was tested during the second quarter of 1996. Conclusions from testing during the second quarter were as follows:

- GNOCIS can be run in closed-loop mode without adversely affecting unit stability, safety, or reliability.
- GNOCIS can achieve NO_x reductions of 10 to 15 percent over the load range.
- An efficiency improvement of about 0.5 percent is achievable.
- Lack of a satisfactory online LOI monitor presents a problem for GNOCIS implementation.

During testing the following constraints were in effect, relative to the current operating levels: (1) change in the coal to each mill was limited to ~5,000 lb/hr, but no change in total coal rate was permitted; (2) change in excess oxygen was limited to ~0.5 percent; and (3) change in OFA damper position was restricted to ~5 percent. Constraints are necessary so that an erroneous input does not result in system upset while in closed-loop operation.

There are basically three modes of operation for GNOCIS: (1) maximize boiler efficiency, (2) minimize NO_x, and (3) minimize LOI. Therefore, when operating with GNOCIS, a decision must be made as to which mode to use. GNOCIS was run in each of these modes to determine what performance gains could be expected if the program's recommendations were followed over the load range. In Mode 2, full load NO_x emissions were reduced by about 14 percent and averaged 11 percent below baseline over the entire load range. Mode 1 operation reduced NO_x emissions by 12 percent at full load, but at loads below 340 MWe, NO_x increased, so that the average over the load range was close to 0 percent. In Mode 3, NO_x averaged 6 percent over baseline. In Mode 1, system efficiency improved about 1 percent at full load and averaged about 0.7 percent over the load range. At full load, the difference in LOI between Mode 2 and Mode 3 was about 4 percent. At low load, the difference in LOI between these two modes was only about 1 percent.

III.A.6 Phase 4C—Unit Optimization Studies

Because of the promising results with the GNOCIS program on boiler operation, the decision was made to evaluate software that could assist with optimizing other components in the power plant, such as the sootblowers, the ESP, and the steam turbine, and software that could integrate the results of these other programs to optimize overall operation of the unit.

III.A.6.a Intelligent Sootblowing System

The objective of this task was to install commercially available sootblowing optimization software and ultimately interface it with the unit optimization software. For this demonstration, PowerGen's Intelligent Sootblowing System (ISBS) was selected.

At Hammond Unit 4, sootblowing was usually initiated once per shift, based on a visual inspection of the furnace by an operator. In order to implement ISBS, it is necessary to develop a correlation between the need for sootblower activity and boiler variables. Using Matlab and

the Fuzzy Logic Toolbox as a development platform, eight rules were developed, which were translated into a PowerGen developed library.

Only limited testing of the ISBS was accomplished before the end of the project. This testing indicated that ISBS could be a useful tool to provide guidance to operators for sootblowing operations. The primary benefit demonstrated when ISBS advice was followed was a substantial reduction of sootblowing steam consumption, which improved boiler efficiency, with no deleterious effect on other operating parameters. The fuzzy rule framework is well suited for this type of process modeling, where direct modeling is very difficult, but plant personnel have extensive knowledge of process interactions and limitations. With a few minor modifications, ISBS could be incorporated into a closed-loop system to initiate sootblower operations automatically without operator intervention.

III.A.6.b Real-Time Heat Rate Package

The objective of this task was to develop software that could monitor boiler heat rate and efficiency in real time. The program runs at specified intervals and obtains process data from the data logger, consolidates and averages this data, performs calculations, and uploads the results to the data logger. The CEP software was validated by comparing calculations from a consistent set of direct method calculations with the results of an indirect method calculation. The program was designed to run continuously, providing results at specified intervals, such as every minute.

The operation of the real-time heat rate program has not been completely satisfactory. In 2002, the program tracked unit performance, but a substantial difference was observed between the program results and other methods of determination. This difference correlated with load and was greatest at mid-load and lower. During the year, the program tracked daily coal burn reasonably well; however, there was a bias between the indirect method and direct measurements, but this bias was not correlated with load, as was the heat rate. The indirect method of determining coal higher heating value showed very little variation, and did not track daily changes as observed in the daily grab samples.

III.A.6.c GNOCIS/Boiler Optimization Package

GNOCIS is discussed in detail 17. As part of Phase 4C, several modifications to the GNOCIS/boiler program were made:

- GNOCIS was interfaced to the real-time data system (RTDS) instead of using a direct connection to the DCS.
- The boiler model was upgraded.
- Online error correction was added.

The reason for an online error correction package was to have a software plug-in to GNOCIS to implement online, continuous model adaptation (in instances where this may be beneficial) with only minor modifications to the GNOCIS software and minimal disruptions to operations.

Insufficient testing was performed to quantify the performance of the GNOCIS models at Hammond. Testing with an interim model was conducted during January 2002, but the result was inconclusive, in part because of the unit's being on economic dispatch during the testing, with resultant load changes.

III.A.6.d Turbine Cycle Optimization

A study conducted by EnTEC found that of all the parameters considered for Hammond Unit 4, steam conditions had the greatest impact on costs. Based on a total plant optimization study, EnTEC recommended that steam turbine parameters—specifically main steam temperature and pressure, and reheat temperature—should be included in the process optimization study. It was estimated that optimizing these parameters could reduce costs by \$457,000/yr. The fact that the ability to reach a target temperature and pressure is highly dependent on boiler operating conditions suggests that the above variables should be the target variables of the boiler optimization system. Also, since these variables are the primary determinants of the turbine's performance, they should be the outputs of the turbine cycle optimization program. It was decided to use the GNOCIS software for this purpose.

At typically one minute intervals, GNOCIS/turbine extracts information from the data logger, performs an optimization calculation, and transmits the current recommendations to the data logger where they can be viewed and action taken, if desired. Insufficient testing was performed to quantify the performance of the system. Open-loop testing with an interim model was conducted during January 2002, but the result was not positive, in part because of the unit's being under economic dispatch with resultant load changes during the testing. As a result of this testing, the model was revised. Further testing is necessary to determine the benefits of this program.

III.A.6.e ESP Performance Optimization

EPRI's ESPert program was chosen for ESP performance optimization. ESPert interfaces with NWL Environmental Technologies' Precipitator Control and Management System (PCAMS) system. Included in PCAMS is an energy management system targeted at reducing operating costs while maintaining opacity levels. Initial expectations were to use the ESPert/PCAMS software as an optimization platform; however, to date it has been used only as a predictive model.

ESPert was integrated into the system and became operational during October 2000. From then until the end of the cooperative agreement, the ESPert/PCAMS system was available only a small part (approximately 1,200 hours) of the actual operating time of the plant. Much of the off-stream time was spent in software development.

III.A.6.f Power Plant Optimization

The objective of the unit optimization framework effort was to develop a framework, including software, to coordinate multiple hierarchical optimizers. This framework provides a method for acquiring input data, running a model, outputting results, and performing an optimization based on an objective function, such as cost, environmental performance, or a combination of these parameters. The optimizers can be written in various programming languages.

The focus of this work was to develop a framework and software to coordinate multiple process optimizers. This package consists of several components, including global optimizers and adaptations of the "package" optimizers and suboptimizers to allow communication with the global optimizer. Although the framework and software will support other global optimizers, two were included in the scope of this project. SCS adapted a PowerGen developed proof-of-concept global optimization algorithm to fit within the framework. The other global optimizer incorporated was one developed by Synengco and marketed in the U.S. by URS. Although

functional, this software requires further testing to ensure that it is operating robustly and reliably.

III.B Environmental Performance

III.B.1 NO_x Emissions

Installation of LNBS has been driven by environmental standards as set forth in the Clean Air Act Amendments of 1990 (CAAA90). These standards required reductions in NO_x emissions emitted from power plants. Especially significant with regard to the use of LNBS were the emission limits of Title IV's Acid Rain NO_x Control Program. NO_x emissions under Title IV were set at 0.50 lb/million Btu, a level easily achieved in this demonstration by installing LNBS and AOFA. NO_x emissions were also limited under Title I, primarily because of the role of NO_x in the formation of ground level ozone. Emission limits in the regulations specified use of reasonably available control technology, namely LNBS or other combustion modifications.

More recently, NO_x emission limits have become more stringent. New source pollution standards (NSPS) for NO_x were revised (September 1998) from an input-based standard of 0.60 lb/million Btu to an output-based regulation of 1.6 lb/MWh of electric power generated. To reduce ozone transport by 2003, NO_x emissions limits under the NO_x State Implementation Plan (SIP) Call are set at 0.15 lb/million Btu for 19 states and the District of Columbia. The Environmental Protection Agency based the revised limits for coal-fired electric utility boilers on the performance that can be achieved by SCR units, either alone or in combination with combustion controls. Therefore, LNBS, as successfully demonstrated in this project, represent an important step toward achievement of today's standards.

III.B.2 Ash Disposal and Utilization

Coal ash is produced in large volumes by the electric utility industry. Although ash was previously landfilled, there are now many potential beneficial uses, including as a lightweight aggregate and fill material, in masonry products and autoclaved cellular concrete, and for civil engineering applications in construction, such as road building. However, the main use of utility ash is in the Portland cement industry, which accounts for well over half of the market for coal ash.

Cement replacement materials are subject to LOI specifications ranging from 4 to 6 percent with low variability. Therefore, it is important to produce ash below this range, even though some beneficiation approaches are being used to bring fly ash LOI within acceptable limits. If operated improperly, LNBS and OFA can increase LOI, resulting in a negative environmental and economic impact on ash management practices. Much of the ash that does not meet specifications cannot be used in concrete and must be landfilled, thus decreasing landfill life and increasing costs. In addition, making Portland cement with coal ash generates less CO₂ per ton of clinker than production from other raw materials. Since reductions in CO₂ can potentially be sold as offsets when CO₂ trading comes into effect, this environmental benefit will not be realized if LOI levels are unacceptable. Furthermore, increased LOI can result in increased fuel cost, since more fuel is required to achieve the same power output (a 10 percent increase in LOI can reduce combustion efficiency by 1 percent), and the environment could be negatively impacted by increased mining activity. Fortunately, the development of control technology, such as GNOCIS, can achieve optimum boiler performance, while meeting NO_x and LOI targets.

III.B.3 GNOCIS

When GNOCIS is operating automatically as a closed-loop supervisory controller, optimum settings for the combustion equipment, such as mills, dampers, and excess air, can be maintained. GNOCIS can handle multiple parameters that impact NO_x/LOI performance tradeoffs across the load range of the unit. The software can be used to minimize unburned carbon in the fly ash, thus reducing LOI while maintaining NO_x emissions at desirable levels. Therefore, the environmental benefit of LNBs can be maximized, and compliance with both air emission and solid waste recycle/reuse regulations can be fully achieved.

IV Market Analysis

Low-NO_x burner development represents a major success for the CCT program. Although DOE had been involved in the early development of low-NO_x burners, by the mid-1980s low-NO_x burners were still an evolving technology, unproven at full-size, commercial scale. The CCT program sponsored several low-NO_x burner demonstrations; one of the most important is the wall-fired demonstration discussed in this PPA. These CCT demonstrations helped push low-NO_x technology over the commercial threshold, so that now low-NO_x burner technology is installed on 75 percent of the nation's coal-burning power plants.

IV.A Market Size

In 2000, the U.S. had about 130,000 MWe of wall-fired generating capacity. LNBs are installed on 100,000 MWe of this capacity, or about 77 percent. This illustrates that the LNB/AOFA technology, as demonstrated by this project, has proven its value and is enjoying a high implementation rate. However, because of its wide use currently, the market for retrofit installation is significantly reduced from its size when this project was initiated. The technology will undoubtedly continue to be implemented on new wall-fired units.

An estimated 35 plants, representing approximately 20,000 MWe of capacity, have either installed, or are in the process of installing, GNOCIS. Since this technology is applicable to essentially any plant, regardless of firing type, the market for GNOCIS is virtually unlimited.

IV.B Economics

The economics for installation of LNBs plus AOFA involve both the capital cost of equipment installation and changes in operating costs due to a different heat rate and maintenance requirements. Lost revenue as a result of downtime for retrofit of the burners and OFA could also be considered, but if the retrofit is accomplished during a scheduled outage, the impact of lost revenue should be small. Also, if system reliability changes, this would need to be taken into account, but in the following economics, costs related to changes in system reliability are assumed to be negligible. All costs involved in the following discussion are in 1995 dollars.

IV.B.1 Capital Cost

Typical capital costs for installation of LNBs on a wall-fired boiler are in the range of \$6 to \$15/kW, and for LNBs plus AOFA, costs are in the range of \$10 to \$20/kW. Costs for the project at Plant Hammond, adjusted downward to allow for the added testing costs of this project, but including some cost sharing by the participants, were:

AOFA	\$3.8 million (\$7.60/kW)
LNBs	\$4.5 million (\$9.00/kW)
LNBs + AOFA	\$8.3 million (\$16.60/kW)
GNOCIS	\$0.25 million (\$0.50/kW)

The GNOCIS cost does not include the cost of a DCS or instrumentation not strictly necessary for GNOCIS operation, such as online carbon-in-ash monitors. However, DCS configuration modifications required to incorporate GNOCIS are included.

Estimates by the participant for costs that could be used for planning to retrofit a 500-MWe power plant similar to Hammond Unit 4 are:

AOFA	\$4.4 million (\$8.80/kW)
LNBS	\$5.0 million (\$10.00/kW)
LNBS + AOFA	\$9.4 million (\$18.80/kW)
GNOCIS	\$0.25 million (\$0.50/kW)

These estimates are based upon actual Hammond Unit 4 costs, as well as cost data available from EPRI and other sources. Of course, site-specific factors, such as boiler size, age, design, furnace configuration, windbox design and condition, plant layout, etc., can significantly affect these estimates. Insufficient data are available to allow estimation of the cost of installing full unit optimization hardware and software.

IV.B.2 Operating Cost

O&M costs will vary depending upon system load. Estimated O&M costs for full-load operation with a 65 percent capacity factor and a coal cost of \$1.20/10⁶ Btu are: \$291,000/year for AOFA, \$165,600/year for LNBS, and \$333,400/year for LNBS plus AOFA. For GNOCIS, three cases were considered: (1) minimize NO_x without consideration of efficiency or LOI, (2) maximize efficiency without consideration of NO_x or LOI, and (3) minimize LOI without consideration of efficiency or NO_x. The estimated annual O&M costs for these three cases are -\$228,000, -\$341,000, and \$231,000, respectively (negative values indicate cost reductions).

IV.B.3 Economic Analysis

Table 12 presents a summary of the system performance data used in preparing estimated economics for the technologies implemented in this project.

Table 12. System Performance Data

Technology	Baseline	AOFA	LNB	LNB plus AOFA	LNB plus AOFA	LNB plus AOFA
Compared to	Baseline				LNB	LNB (Adj.) ^a
Boiler Efficiency, %	90	89.2	89.3	88.7	88.7	88.7
Efficiency Change, %	----	-0.8	-0.7	-1.3	-0.6	-0.6
Turbine Heat Rate, Btu/kWh	9,000	8,999	8,975	8,960	8,960	8,960
Unit Heat Rate, Btu/kWh	10,000	10,089	10,050	10,101	10,101	10,101
Net Heat Rate Change, %	----	0.89	0.50	1.01	0.51	-0.51
Annual O&M Cost, \$	----	290,968	165,556	333,351	167,795	167,795
NO _x , lb/10 ⁶ Btu	1.24	0.94	0.65	0.40	0.40	0.40
NO _x Reduction, %	----	24	48	68	38	22
NO _x Reduction, tons/yr	----	4,143	8,117	11,615	3,457	1,521
Capital Cost, \$ million	----	4.4	5.0	9.4	4.4	4.4

^a Part of the reduction in NO_x for the case listed in the next to last column is due to factors other than the addition of AOFA. When adjustments are made for these other factors, the NO_x reduction due to the addition of AOFA decreases from 38 percent to 22 percent.

The factors used to calculate capital charges and levelized O&M costs for the economic analysis are given in Table 13. Table 14 presents the economics for retrofitting AOFA, LNBS, and LNB plus AOFA on a 500-MWe wall-fired boiler. Both the incremental cost of electric power and the cost per ton of NO_x removed are presented. The results in Table 14 are based on the information in Tables 12 and 13.

Table 13. Capital Charge and Levelizing Factors

	Current Dollars	Constant Dollars
Capital Charge Factor	0.160	0.124
O&M Levelization Factor	1.314	1.000

Table 14. Economics for Adding NO_x Control to a 500-MWe Wall-Fired Boiler

	AOFA		LNBS		LNB plus AOFA	
	Current \$	Constant \$	Current \$	Constant \$	Current \$	Constant \$
Incremental Cost of Power, mills/kWh						
Capital Charge	0.25	0.19	0.28	0.22	0.53	0.41
Fixed O&M	0.00	0.00	0.00	0.00	0.00	0.00
Variable O&M	0.13	0.10	0.08	0.06	0.15	0.12
Total	0.38	0.29	0.36	0.28	0.68	0.53
Levelized Cost of NO_x Removal, \$/ton						
Capital Charge	170	132	99	76	129	100
Fixed O&M	0	0	0	0	0	0
Variable O&M	92	70	27	20	38	29
Total	262	202	126	96	167	129

These results indicate that the combination of LNBS plus AOFA is relatively efficient at achieving NO_x reduction. This combination of technologies is able to achieve almost 70 percent NO_x reduction at a cost of about \$130/ton on a constant dollar basis (\$170/ton on a current dollar basis). This is considerably cheaper than costs for SCR and SNCR, provided 70 percent removal is sufficient to meet permit requirements and LOI is not a problem. If higher than 70 percent NO_x removal is required, LNBS plus AOFA can be installed in conjunction with SCR or SNCR, thus reducing the size of these post-combustion installations and reducing overall costs.

Table 15 presents the economics for adding GNOCIS to a 500-MWe wall-fired boiler. Because the operation of GNOCIS produces increased efficiency for both the minimize NO_x and maximize efficiency modes, there is a net savings in operating costs. Thus, there is a rapid recovery of the investment for GNOCIS installation. The results shown are for full-load operation, and will be somewhat different for other loads, since performance is a function of load.

Table 15. Economics for Adding GNOCIS Technology to a 500-MWe Wall-Fired Boiler

	Minimize NO _x		Maximize Efficiency		Minimize LOI	
	Current \$	Constant \$	Current \$	Constant \$	Current \$	Constant \$
Incremental Cost of Power, mills/kWh						
Capital Charge	0.02	0.01	0.02	0.01	0.02	0.01
Fixed O&M	0.00	0.00	0.00	0.00	0.00	0.00
Variable O&M	-0.11	-0.08	-0.16	-0.12	0.10	0.08
Total	-0.09	-0.07	-0.14	-0.11	0.12	0.09
Levelized Cost of NO_x Removal, \$/ton						
Capital Charge	57	45	58	45	----	----
Fixed O&M	0	0	0	0	----	----
Variable O&M	-430	-328	-646	-491	----	----
Total	-373	-283	-588	-446	^a	^a

^a The cost of NO_x removal cannot be calculated for this case, because NO_x actually increased.

V Conclusions

Installation of LNBs plus AOFA can achieve significant NO_x reductions on wall-fired boilers. AOFA achieved about 20 percent NO_x reduction, and LNBs achieved about 50 percent NO_x reduction. Together they achieved about 67 percent, exceeding the target objective of the project. NO_x reduction was found to vary with load, being somewhat less effective at low loads.

Performance degradation generally accompanies the installation of LNBs plus AOFA. At Plant Hammond Unit 4, performance degradation included increased CO and fly ash LOI, increased combustion air requirement, and higher furnace exit gas temperature. These adverse impacts were to some extent mitigated by improvements in steam temperature. Low-NO_x technologies may also impact other plant systems, such as the ESP. In general, tests showed that parameter changes that improve LOI have the opposite effect on NO_x. This complicates unit operation and provides the opportunity for beneficial use of computer controls.

On a dollars per ton of NO_x removed basis, LNBs plus AOFA technology is among the most cost effective. However, if other plant equipment must be upgraded, such as the ESP or the control system, these costs must be included in the project total and will have a slight negative impact on economic performance.

If a DCS is present, the installation of GNOCIS on the boiler is relatively inexpensive, and can significantly improve plant operations by allowing the unit to operate at optimum conditions for a greater percentage of the time. As part of this project, optimization packages were installed on other plant units, such as the sootblowers, ESP, and turbine, and these were tied into a top-level global optimizer. This approach holds great promise for further improvements in power plant operations. Although this system was functional by the end of the cooperative agreement, not enough test time had been accomplished to quantify the benefits.

This was a successful project that achieved its objective of demonstrating that low-NO_x burners plus AOFA can be installed on a wall-fired boiler to significantly decrease NO_x emissions. The project also showed that optimization software, such as GNOCIS, ISBS, and ESPert, can be successfully installed on a power plant and show potential for improving economics and mitigating some of the negative effects of LNBs, such as increased LOI and decreased efficiency.

This project, along with several other low-NO_x burner projects sponsored by the CCT program, helped push low-NO_x technology over the commercial threshold, so that low-NO_x burner technology is now installed on 75 percent of the nation's coal-burning power plants.

Acronyms and Abbreviations

ADC	Advanced Digital Control
AOFA	Advanced Overfire Air
Btu	British thermal unit
B&W	Babcock & Wilcox
CAAA90	Clean Air Act Amendments of 1990
CCT	Clean Coal Technology
CEM	Continuous emissions monitor
CEP	Center of Electric Power
CO	Carbon monoxide
DCS	Distributed Control System
DOE	Department of Energy
EnTEC	Energy Technology Consultants, Inc.
EPRI	Electric Power Research Institute
ESP	Electrostatic precipitator
ESPerT	EPRI's ESP diagnostic software
FWEC	Foster Wheeler Energy Corporation
GNOCIS	Generic NO _x Control Intelligent System
H	Hydrogen atom
HAPs	Hazardous air pollutants
HHV	Higher heating value
H ₂ S	Hydrogen sulfide
ISBS	Intelligent Sootblowing System
LNB	Low-NO _x burner
LOI	Loss on ignition
MWe	Megawatts electric
N	Nitrogen atom
N ₂	Nitrogen
NO	Nitric oxide
NO _x	Nitrogen oxides
NSPS	New Source Pollution Standards
O	Oxygen atom

O ₂	Oxygen
OFA	Overfire air
OH	Hydroxyl radical
PCAMS	Precipitator Control and Management System
PPA	Post Project Assessment
SCR	Selective catalytic reduction
SCS	Southern Company Services
SNCR	Selective noncatalytic reduction
SO ₂	Sulfur dioxide
SO ₃	Sulfur trioxide
SO _x	Sulfur oxides
U.K.	United Kingdom

References

- Radian Corporation. 1993. *500 MW Demonstration of Advanced Wall-fired Combustion Techniques for the Reduction of Nitrogen Oxide (NO_x) Emissions from Coal-Fired Boilers—Field Chemical Emissions Monitoring: Overfire Air and Overfire Air/Low NO_x Burner Operation Final Report*. DCN-93-209-061-01; DOE Contract No. DE-FC22-90PC89651. Springfield, VA: National Technical Information Service.
- Southern Company Services and Radian Corporation. 1993. *500 MW Demonstration of Advanced Wall-Fired Combustion Techniques for the Reduction of Nitrogen Oxide (NO_x) Emissions from Coal-Fired Boilers: Field Chemical Emissions Monitoring: Overfire Air and Overfire Air/Low NO_x Burner Operation: Final Report*. DOE/PC/89651-T16. Springfield, VA: National Technical Information Service.
- Southern Company Services and Radian Corporation. 1995. *500 MW Demonstration of Advanced Wall-Fired Combustion Techniques for the Reduction of Nitrogen Oxide (NO_x) Emissions from Coal-Fired Boilers - Phase 3 and Final Environmental Monitoring Program Report*. DOE Contract No. DE-FC22-09PC89651.
- Southern Company Services. 1996. *500 MW Demonstration of Advanced Wall-Fired Combustion Techniques for the Reduction of Nitrogen Oxide (NO_x) Emissions from Coal-Fired Boilers Public Design Report*. DOE/PC/89651-T23. Springfield, VA: National Technical Information Service.
- Southern Company Services. 1998a. *500 MW Demonstration of Advanced Wall-Fired Combustion Techniques for the Reduction of Nitrogen Oxide (NO_x) Emissions from Coal-Fired Boilers—Final Report Phases 1-3B*. DOE/PC/89651-T30. Springfield, VA: National Technical Information Service
- Southern Company Services. 1998b. *500 MW Demonstration of Advanced Wall-Fired Combustion Techniques for the Reduction of Nitrogen Oxide (NO_x) Emissions from Coal-Fired Boilers—Phase 4 Digital Control System and Optimization*. DOE Contract No. DE-FC22-90PC89651.
- Southern Company Services. 2003. *Unit Optimization Project at Hammond Unit 4*. DOE Contract No. DE-FC22-90PC89651.
- U.S. Department of Energy. 1989. *Demonstration of Advanced Combustion Techniques for a Wall-Fired Boiler*. Comprehensive Report to Congress Clean Coal Technology Program. DOE/FE-0146

Bibliography

- Sorge, J.N., and A.L. Baldwin. 1992. "500 MW Wall-Fired Low NO_x Burner Demonstration." Paper presented at the First Annual Clean Coal Technology Conference, Cleveland, OH, September 1992.
- Sorge, J.N., and A.L. Baldwin. 1993. "Performance and Operating Results from the Demonstration of Advanced Combustion Techniques for Wall-Fired Boilers." Paper presented at the Second Annual Clean Coal Technology Conference, Atlanta, GA. September 1993.
- Sorge, J.N., C.L. Larrimore, M.D. Slatsky, W.R. Menzies, S.M. Smouse, and J.W. Stallings. 1997. "500 MW Demonstration of Advanced Wall-Fired Combustion Techniques for the Reduction of Nitrogen Oxide Emissions from Coal-Fired Boilers." Paper presented at the Fifth Annual Clean Coal Technology Conference. Tampa, FL, January 1997.
- Sorge, J.N., W.R. Menzies, S.M. Smouse, and J.W. Stallings. 1995. "500 MW Demonstration of Advanced Wall-Fired Combustion Techniques for the Reduction of Nitrogen Oxide Emissions from Coal-Fired Boilers. Paper presented at the Fourth Annual Clean Coal Technology Conference. Denver, CO, September 1995.
- Sorge, J.N., and S.M. Wilson. 1994. "500 MW Demonstration of Advanced Wall-Fired Combustion Techniques for the Reduction of Nitrogen Oxide Emissions from Coal-Fired Boilers." Paper presented at the Third Annual Clean Coal Technology Conference. Chicago, IL, September 1994.
- Southern Company Services and Energy Technology Consultants. 1991. *500 MW Demonstration of Advanced Wall-Fired Combustion Techniques for the Reduction of Nitrogen Oxide (NO_x) Emissions from Coal-Fired Boilers—Phase 1 Baseline Tests Report*. DOE/PC/89651-T2. Springfield, VA: National Technical Information Service
- Southern Company Services and Energy Technology Consultants. 1992. *500 MW Demonstration of Advanced Wall-Fired Combustion Techniques for the Reduction of Nitrogen Oxide (NO_x) Emissions from Coal-Fired Boilers—Phase 2 Overfire Air Tests*. DOE/PC/89651-T5. Springfield, VA: National Technical Information Service.
- Southern Company Services and Radian Corporation. 1993. *500 MW Demonstration of Advanced Wall-Fired Combustion Techniques for the Reduction of Nitrogen Oxide (NO_x) Emissions from Coal-Fired Boilers—Environmental Monitoring Program Report of Phase 2 (Overfire Air Tests)*. DOE Contract No. DE-FC22-90PC89651.
- Southern Company Services and Radian Corporation. 1993. *500 MW Demonstration of Advanced Wall-Fired Combustion Techniques for the Reduction of Nitrogen Oxide (NO_x) Emissions from Coal-Fired Boilers—Environmental Monitoring Program Report of Phase 1 (Baseline Tests)*. DOE Contract No. DE-FC22-90PC89651.
- Southern Company Services and Energy Technology Consultants. 1993. *500 MW Demonstration of Advanced Wall-Fired Combustion Techniques for the Reduction of Nitrogen Oxide (NO_x) Emissions from Coal-Fired Boilers—Phase 3B LNB Plus AOFA Tests Topical Report*. DOE/PC/89651-T17. Springfield, VA: National Technical Information

Service.

Southern Company Services and Energy Technology Consultants. 1994. *500 MW Demonstration of Advanced Wall-Fired Combustion Techniques for the Reduction of Nitrogen Oxide (NO_x) Emissions from Coal-Fired Boilers—Phase 3A Low NO_x Burner Tests Topical Report*. DOE/PC/89651-T15. Springfield, VA: National Technical Information Service.

U.S. Department of Energy. 1996. *Clean Coal Technology—Reducing Emissions of Nitrogen Oxides via Low-NO_x Burner Technologies*. Topical Report Number 5. Springfield, VA: National Technical Information Service.