

APPROACH & DEPARTURE FLARE WITH FLARED ANCHOR TERMINAL (FAT)

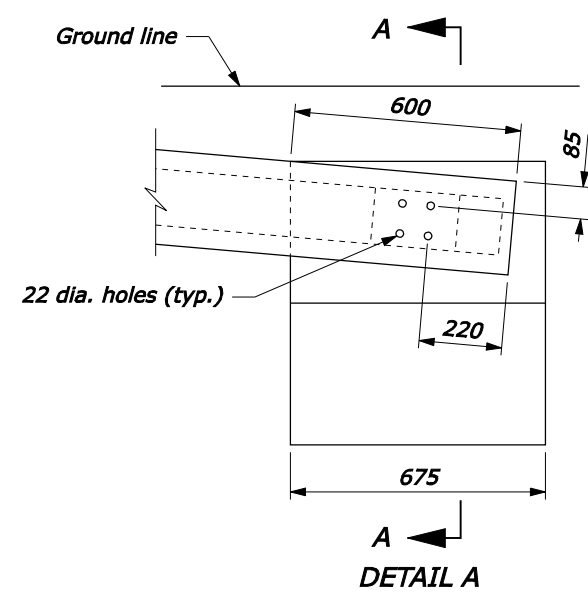

CONCRETE ANCHOR

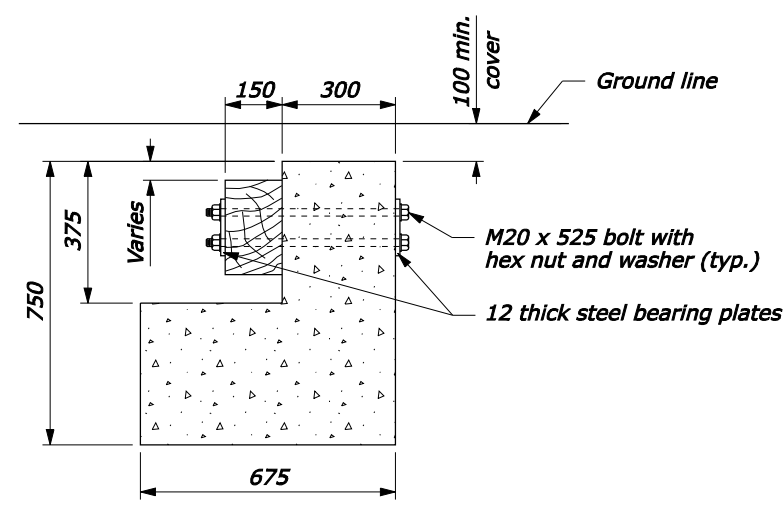

SECTION A-A

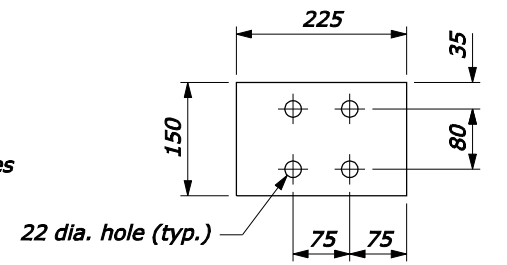

STEEL BEARING PLATE

GUARDRAIL FLARE RATE TABLE			
Design Speed (km/h)	Shy line offset (m)	Flare rate inside shy line (a:b)	Flare rate outside shy line (a:b)
100	2.5	26:1	14:1
80	2.0	21:1	11:1
60	1.5	16:1	8:1
50 or less	1.0	13:1	7:1

NOTE:

1. Extend the fill widening a minimum of 1.5 m behind the guardrail, unless otherwise directed by the CO.
2. The guardrail flare shown in the plan view is the minimum length and rate required. As directed by the CO, flare the guardrail so that the terminal section is outside the clear zone. If the terminal section cannot be located outside the clear zone, it should be flared as far as practical from the road at the maximum rate indicated on the Guardrail Flare Rates table.
3. See Standard M617-60, Steel-Backed Timber Guardrail, Type SBTA and SBTB, for timber, structural steel, and hardware details.
4. On the Type A, blocked-out guardrail, include the blocks in terminal section, except on the concrete anchor. For the Type B, non-blocked-out guardrail, no blocks are included.
5. Furnish hardware in the metric sizes shown. Equivalent US Customary sizes may be used when metric sizes are not available.
6. Dimensions without units are millimeters.

U.S. DEPARTMENT OF TRANSPORTATION
 FEDERAL HIGHWAY ADMINISTRATION
 FEDERAL LANDS HIGHWAY

METRIC STANDARD

**STEEL-BACKED TIMBER GUARDRAIL
 TERMINAL SECTION
 TYPE SBT-FAT**

STANDARD APPROVED FOR USE 3/1996

REVISD: 6/2005
 DRAFT: 9/2007

STANDARD
M617-61

NO SCALE

01-Oct-2007 06:22 AM

F:\StandDraw\std61761.dgn [Metric]