

**APPROACH & DEPARTURE FLARE WITH FLARED ANCHOR TERMINAL (FAT)**

**NOTE:**

1. Extend the fill widening a minimum of 5 feet behind the guardrail, unless otherwise directed by the CO.
2. The guardrail flare shown in the plan view is the minimum length and rate required. As directed by the CO, flare the guardrail so that the terminal section is outside the clear zone. If the terminal section cannot be located outside the clear zone, it should be flared as far as practical from the road at the maximum rate indicated on the Guardrail Flare Rates table.
3. See Standard 617-60, Steel-Backed Timber Guardrail, Type SBTA and SBTB, for timber, structural steel, and hardware details.
4. On the Type A, blocked-out guardrail, include the blocks in terminal section, except on the concrete anchor. For the Type B, non-blocked-out guardrail, no blocks are included.

Design Speed (mph)	Shy line offset (ft)	Flare rate inside shy line (a:b)	Flare rate outside shy line (a:b)
60	8.0	26:1	14:1
50	6.5	21:1	11:1
40	5.0	16:1	8:1
30 and less	3.5	13:1	7:1

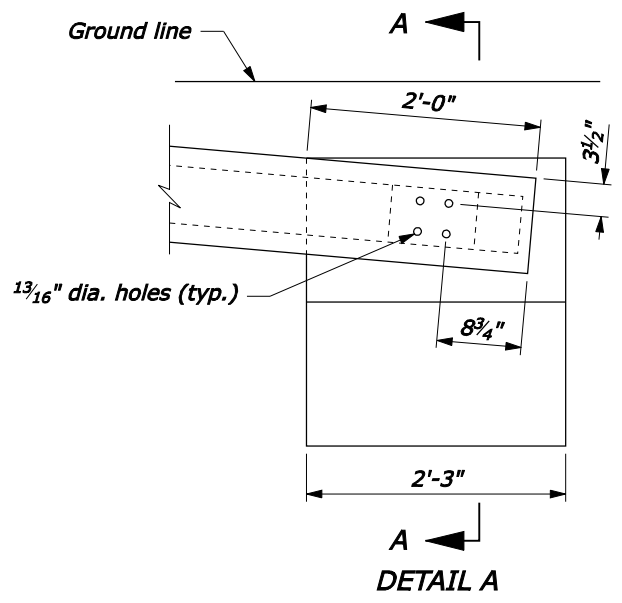

**CONCRETE ANCHOR**

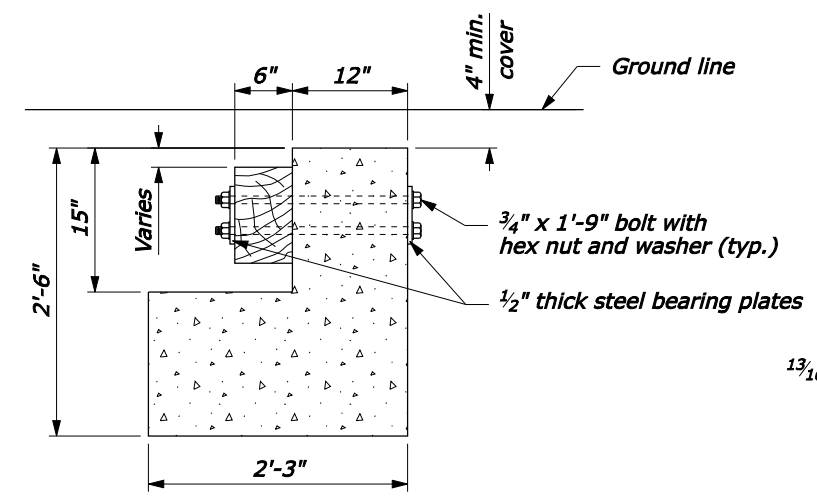

**SECTION A-A**

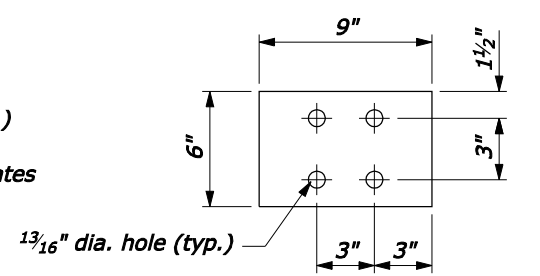

**STEEL BEARING PLATE**

NO SCALE

U.S. DEPARTMENT OF TRANSPORTATION  
 FEDERAL HIGHWAY ADMINISTRATION  
 FEDERAL LANDS HIGHWAY

U.S. CUSTOMARY STANDARD  
**STEEL-BACKED TIMBER GUARDRAIL  
 TERMINAL SECTION  
 TYPE SBT-FAT**

STANDARD APPROVED FOR USE 1/1990	STANDARD
REVISED: 4/1994 6/2005	617-61
DRAFT: 9/2007	

F:\StandDraw\std61761.dgn [US Customary] 01-Oct-2007 06:33 AM