

FOR COMMENT

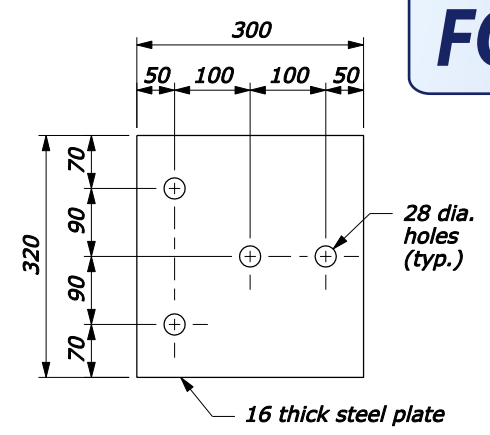

BEARING PLATE

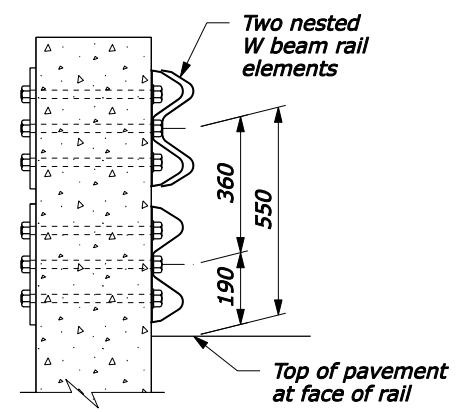

SECTION A-A

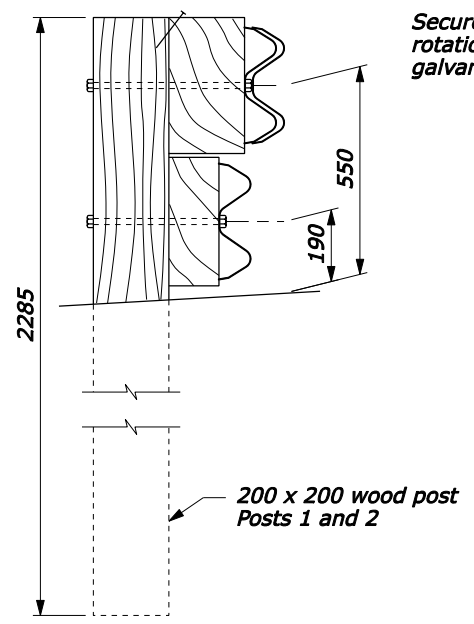

SECTION B-B

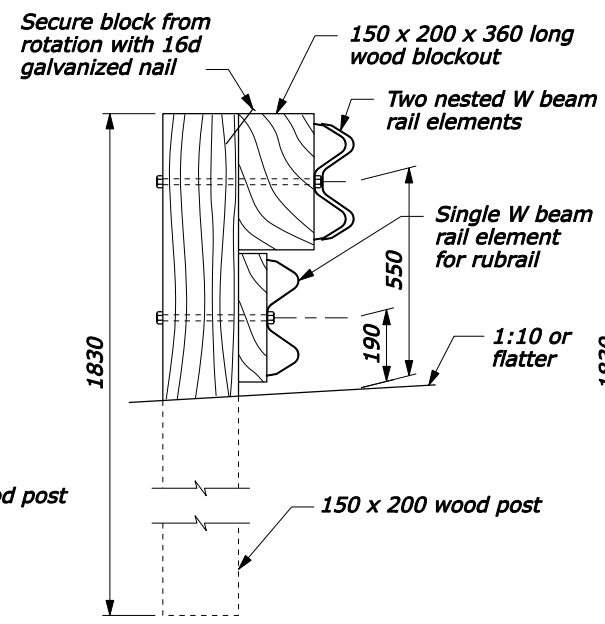

SECTION C-C

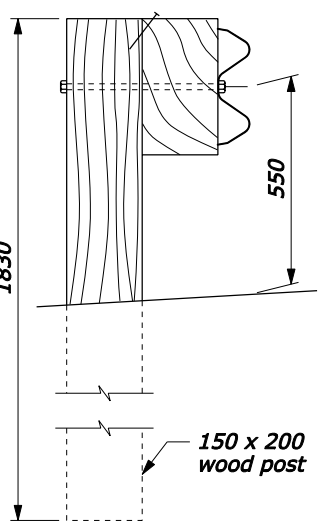

SECTION D-D

- NOTE:**
1. The rubrail may be shop bent in the last 950 mm to facilitate installation.
 2. CENTER drill wood blocks for rubrail located on posts 1 through 4. Secure blocks to post 1 through 3 with M16 carriage bolts.
 3. Posts 1, 2, 3, 4 and 6 require an additional hole to attach lower wood blocks and/or the rubrail.
 4. Do not bolt nested W beam or rubrail W beam to posts and blocks on posts 1, 2, 3 and 5. Bolt blocks directly to posts.
 5. Reinforced concrete wall or bridge parapet must be capable of developing a 265 kN pull out strength.
 6. Furnish hardware in the metric sizes shown. Equivalent US Customary sizes may be used when metric sizes are not available.
 7. Dimensions without units are millimeters.

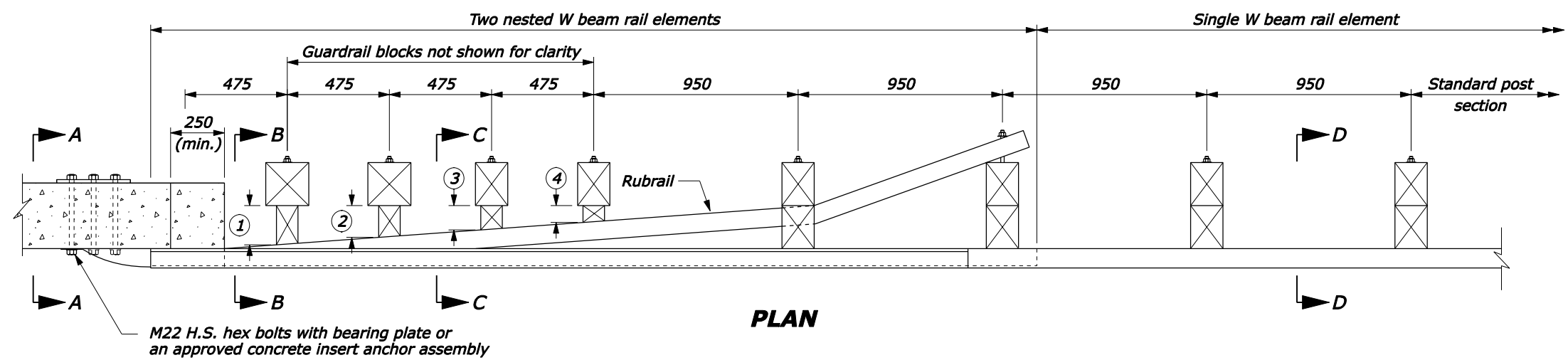

PLAN

WOOD BLOCKS FOR RUBRAIL		
POST	THICKNESS 1	THICKNESS 2
①	164	158
②	131	125
③	99	93
④	67	61
⑤	NO BLOCK	NO BLOCK

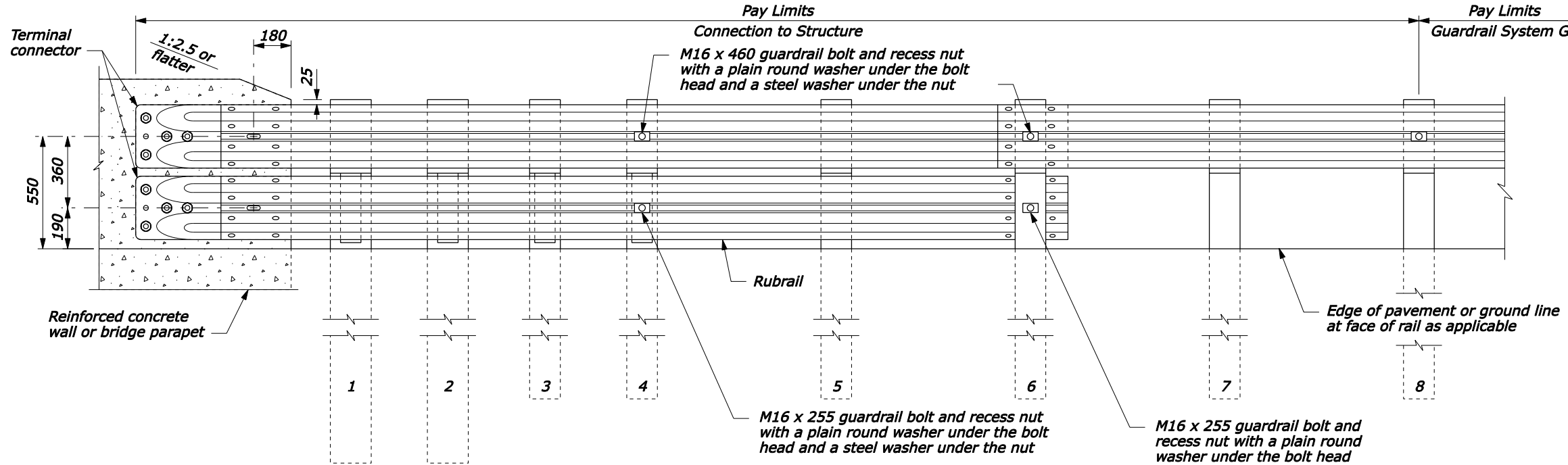

ELEVATION

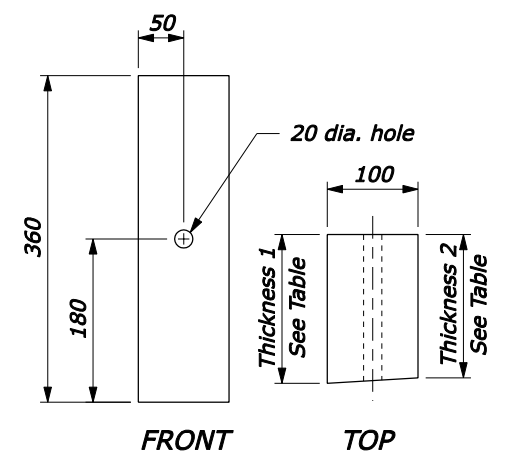

WOOD BLOCK FOR RUBRAIL

U.S. DEPARTMENT OF TRANSPORTATION
FEDERAL HIGHWAY ADMINISTRATION
FEDERAL LANDS HIGHWAY

METRIC STANDARD
G4 W-BEAM GUARDRAIL CONNECTION TO VERTICAL FACE STRUCTURE WOOD POSTS

STANDARD APPROVED FOR USE 3/1996
REVISOR: DRAFT: 5/2005

STANDARD M617-25

NO SCALE

5/2/2005 F:\StanDraw\Draw\18\181725.dgn [Metric]