

TYPICAL INSTALLATION CURB SECTION

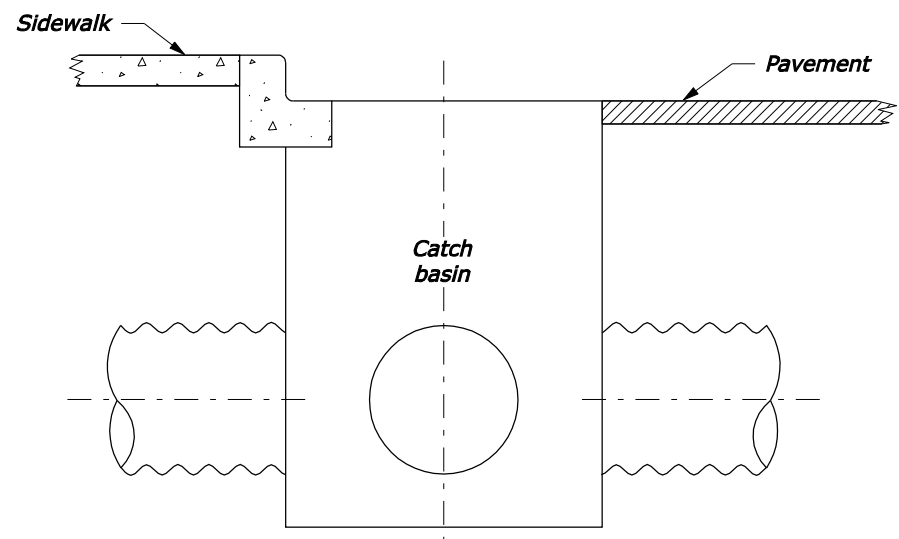

TYPICAL INSTALLATION CURB AND GUTTER SECTION

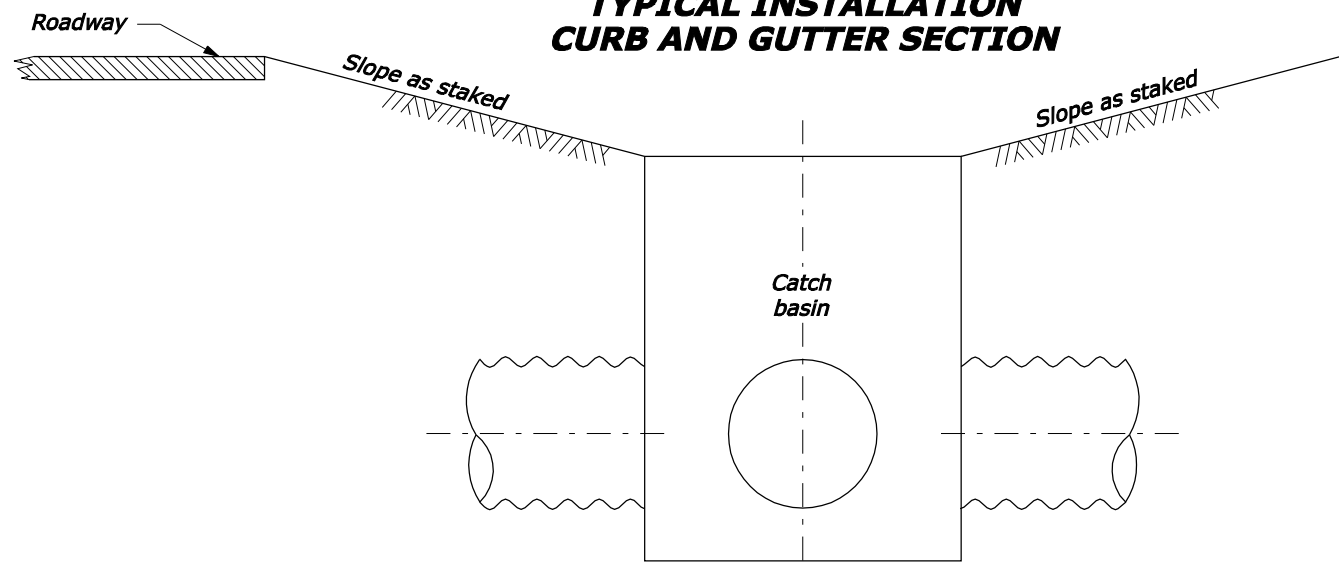

TYPICAL INSTALLATION DITCH SECTION

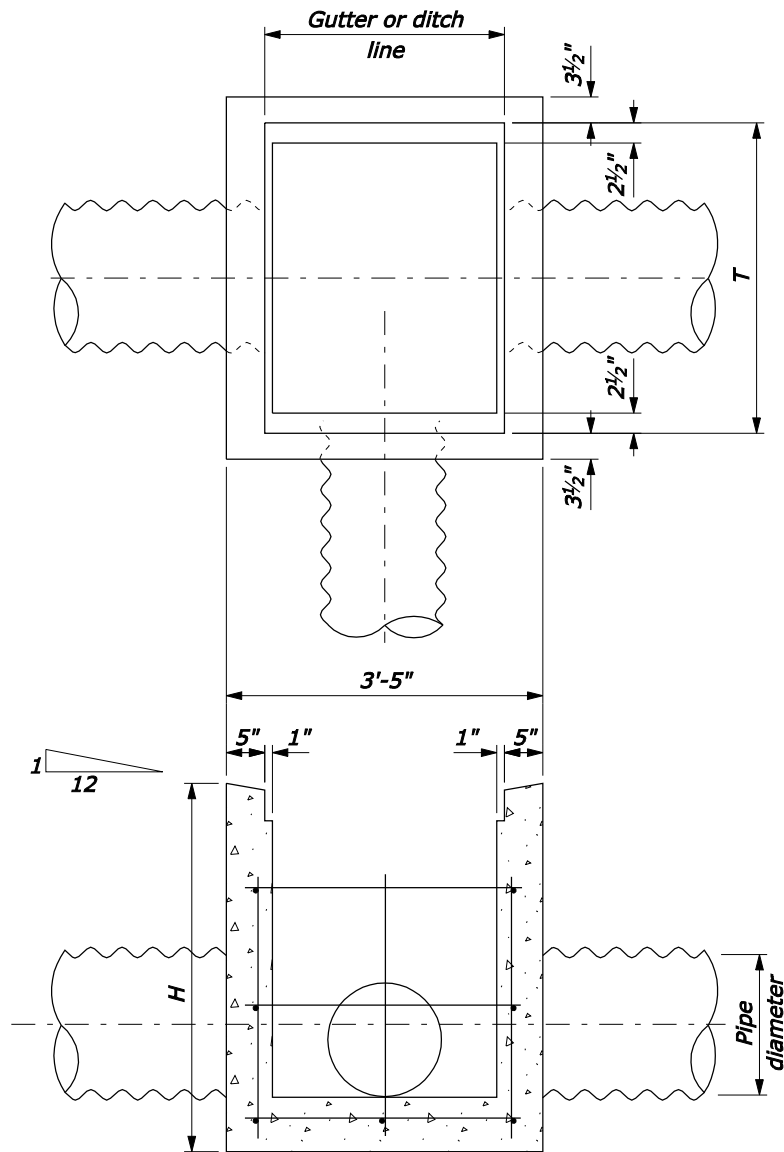

All reinforcing steel #4 at 12"±.
Bend to clear pipe

INLET DETAIL

NOTE:

1. CONCRETE: Chamfer exposed edges 3/4" unless otherwise shown. Give all concrete surfaces a Class 1 finish.
2. The minimum concrete cover to the face of any bar is 2" unless otherwise shown.
3. See Standard 604-2 for Type A Frame and Grate and Standard 604-3 for Type B Frame and Grate.

CONCRETE CATCH BASINS			
PIPE SIZE DIAMETER	DEPTH H	FRAME AND GRATE T	
		TYPE A	TYPE B
12"	3'-0"	2'-6"	2'-6"
18"	3'-0"	2'-6"	2'-6"
24"	4'-0"	3'-3"	3'-4"
30"	4'-0"	4'-0"	4'-2"
36"	4'-6"	4'-9"	5'-0"
42"	5'-0"	5'-6"	5'-5"
48"	5'-6"	6'-3"	6'-3"

CONCRETE CATCH BASINS				
PIPE SIZE DIAMETER INCHES	ESTIMATED QUANTITIES			
	CONCRETE CUYD	REINFORCING STEEL LB	FRAME AND GRATE LB	
			TYPE A	TYPE B
12	0.7	54	215	238
18	0.7	54	215	238
24	1.1	81	271	314
30	1.2	92	327	390
36	1.5	101	383	466
42	1.8	131	439	504
48	2.2	151	495	580

NO SCALE

U.S. DEPARTMENT OF TRANSPORTATION
FEDERAL HIGHWAY ADMINISTRATION
FEDERAL LANDS HIGHWAY

U.S. CUSTOMARY STANDARD

**CATCH BASIN
TYPE 1**

STANDARD APPROVED FOR USE 6/2005
REVISED:

STANDARD
604-1

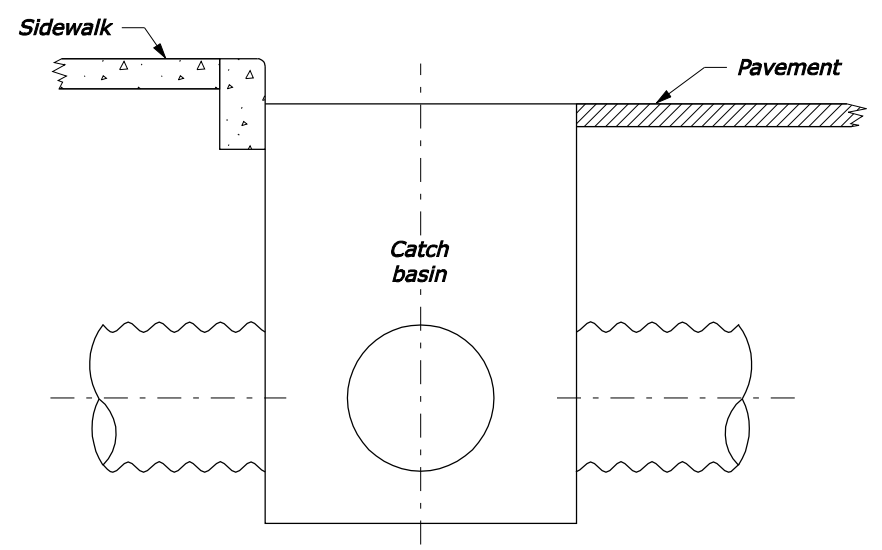

TYPICAL INSTALLATION CURB SECTION

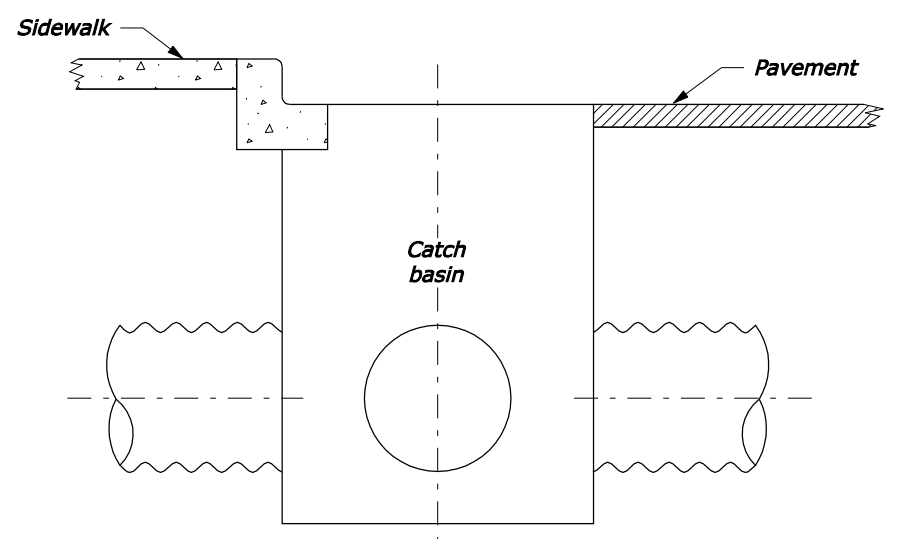

TYPICAL INSTALLATION CURB AND GUTTER SECTION

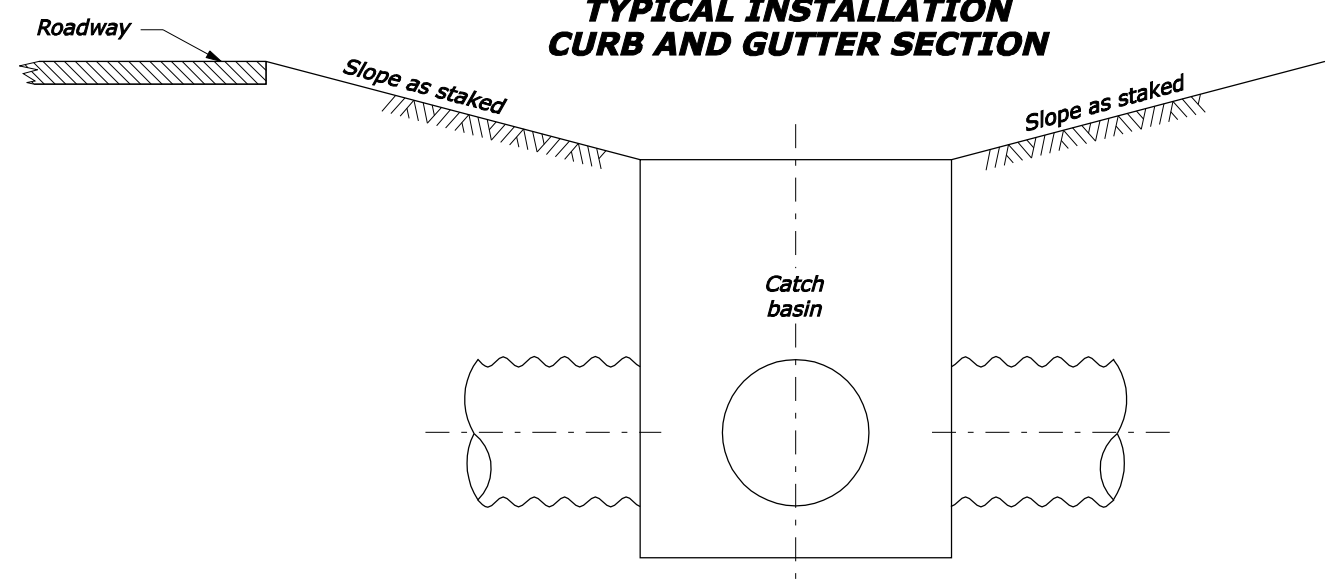

TYPICAL INSTALLATION DITCH SECTION

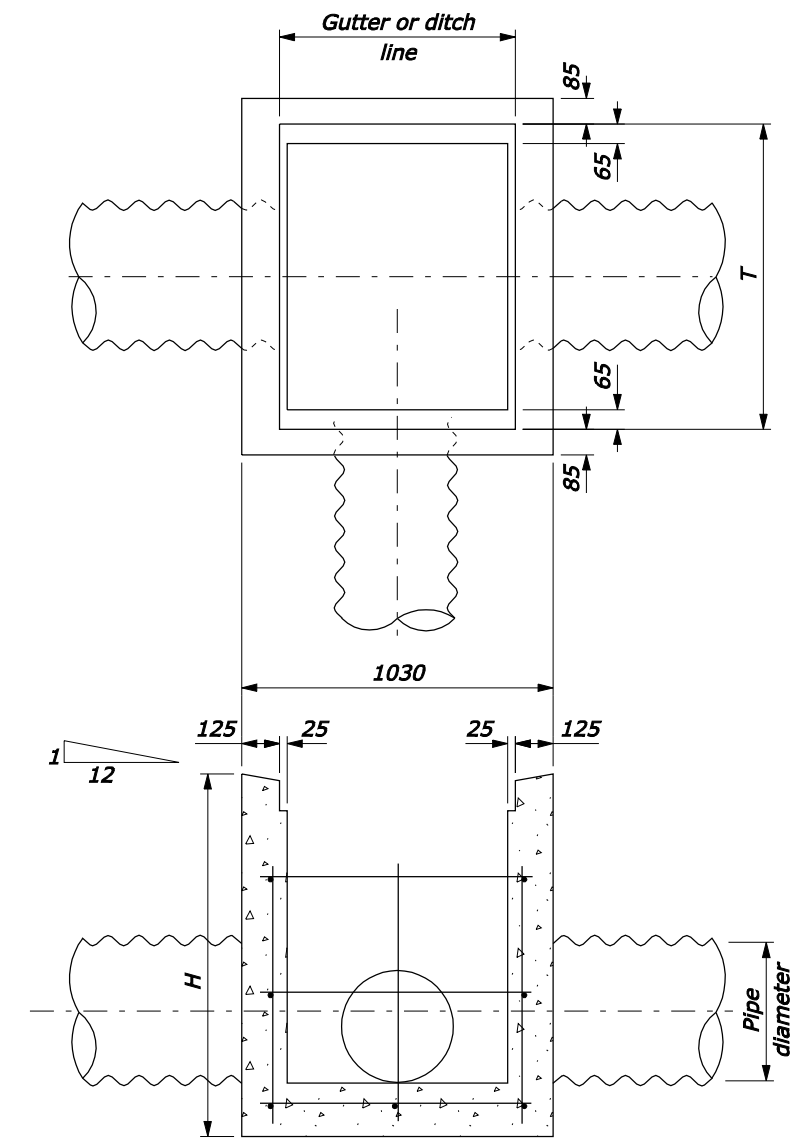

All reinforcing steel #13 at 300 mm±. Bend to clear pipe

INLET DETAIL

NOTE:

1. CONCRETE: Chamfer exposed edges 20 mm unless otherwise shown. Give all concrete surfaces a Class 1 finish.
2. The minimum concrete cover to the face of any bar is 50 mm unless otherwise shown.
3. See Standard M604-2 for Type A Frame and Grate and Standard M604-3 for Type B Frame and Grate.
4. Dimensions without units are millimeters.

CONCRETE CATCH BASINS			
PIPE SIZE DIAMETER	DEPTH H	FRAME AND GRATE T	
		TYPE A	TYPE B
300	900	780	780
450	900	780	780
600	1200	1010	1020
750	1200	1240	1260
900	1350	1470	1500
1050	1500	1700	1680
1200	1650	1930	1920

CONCRETE CATCH BASINS				
PIPE SIZE DIAMETER	ESTIMATED QUANTITIES			
	CONCRETE m³	REINFORCING STEEL kg	FRAME AND GRATE kg	
			TYPE A	TYPE B
300	0.6	24	98	108
450	0.6	24	98	108
600	0.8	37	123	142
750	0.9	42	148	177
900	1.2	46	174	211
1050	1.4	59	199	263
1200	1.7	68	225	297

NO SCALE

U.S. DEPARTMENT OF TRANSPORTATION
 FEDERAL HIGHWAY ADMINISTRATION
 FEDERAL LANDS HIGHWAY

METRIC STANDARD

CATCH BASIN TYPE 1

STANDARD APPROVED FOR USE 3/1996
 REVISED: 5/1997 6/2005

STANDARD M604-1

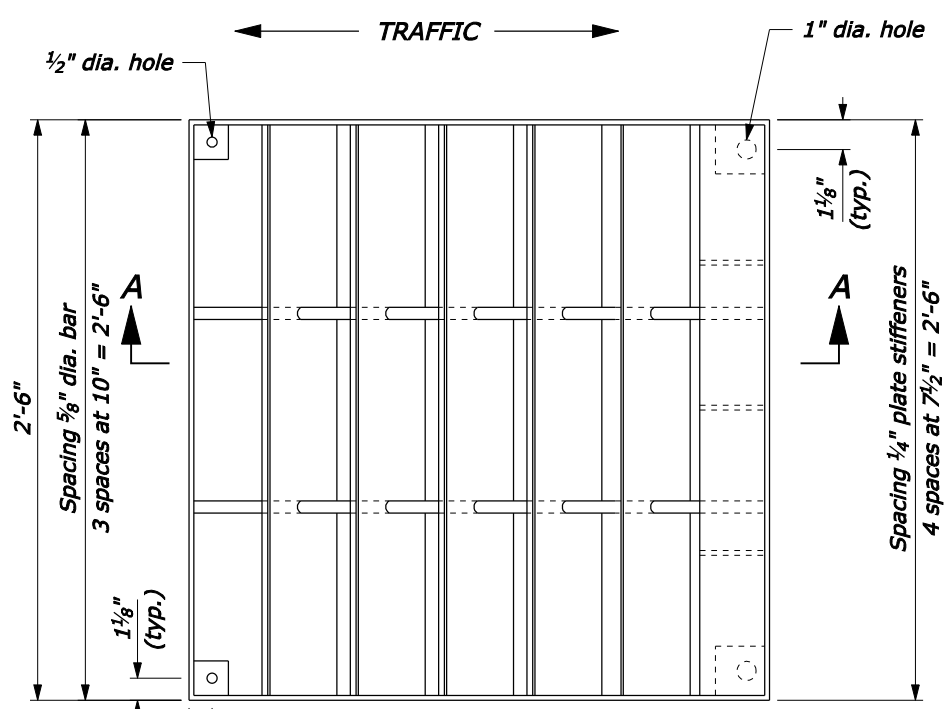
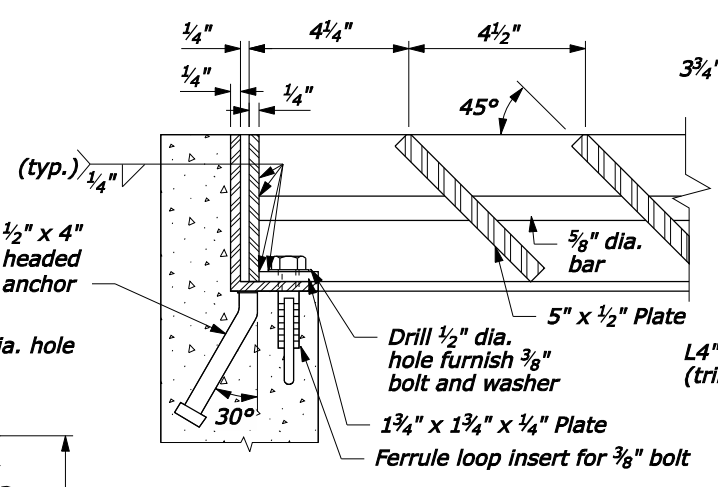
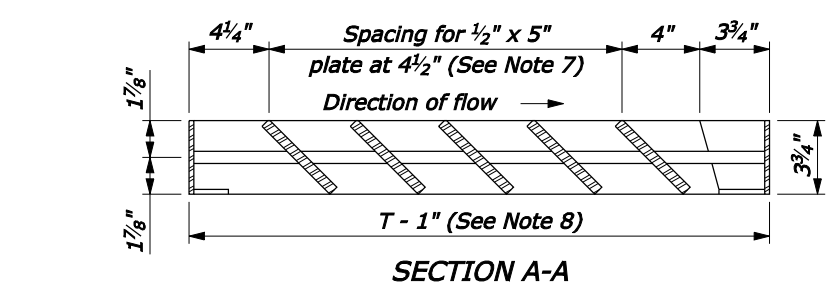

SECTION B-B

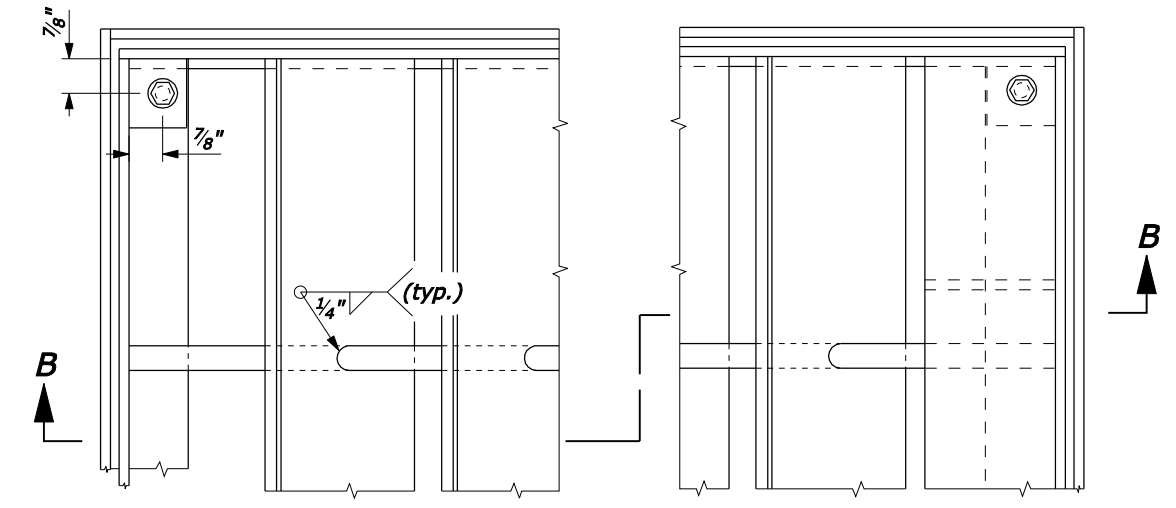

FRAME AND GRATE DETAILS

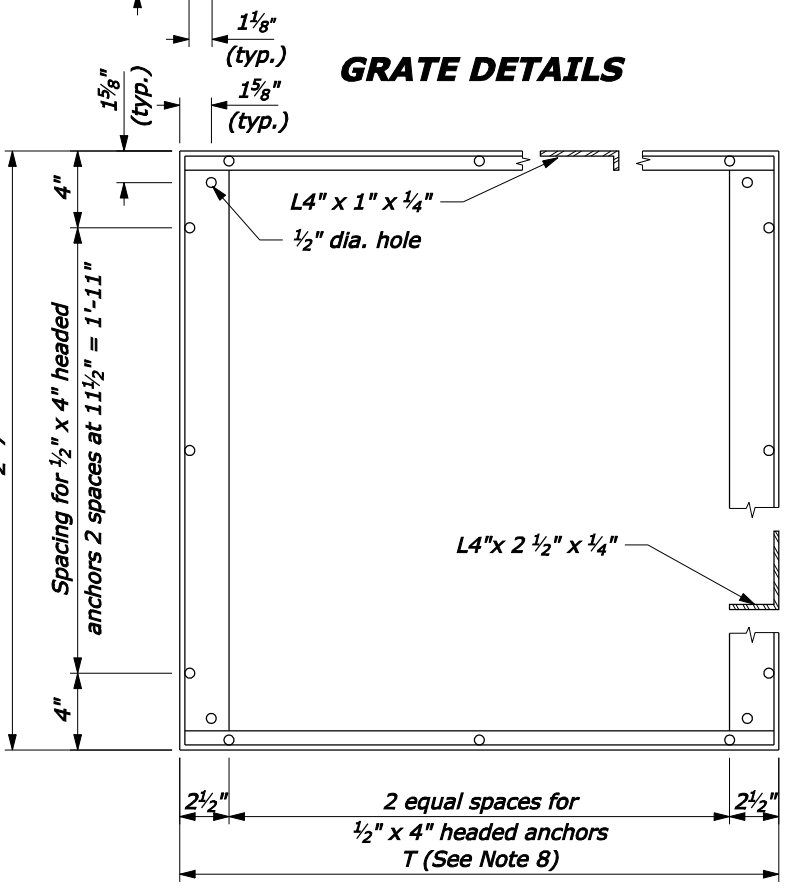

FRAME DETAIL

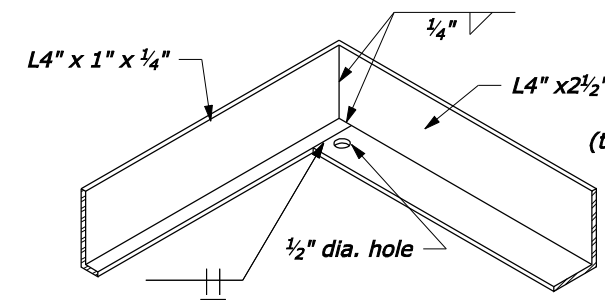

FRAME CORNER DETAIL

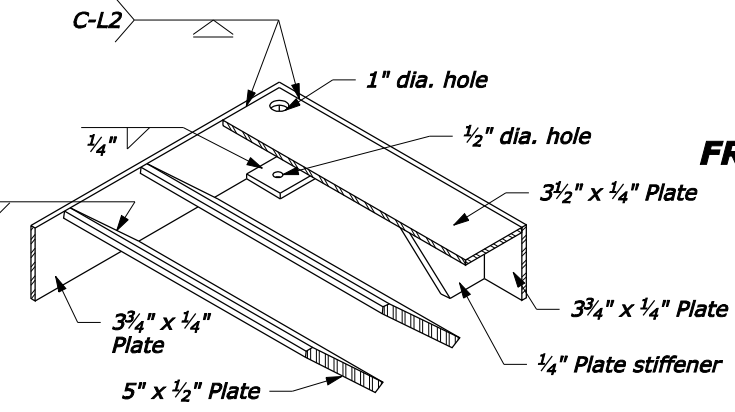

GRATE CORNER DETAIL

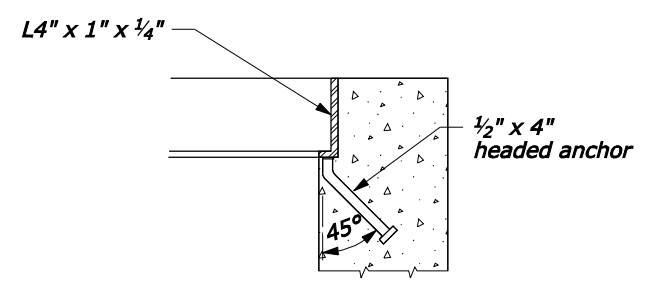

FRAME ANCHOR DETAIL

- NOTE:**
1. **STRUCTURAL STEEL:** AASHTO M 183 (ASTM A 36M).
 2. **BOLTS & WASHERS:** ASTM A 307, Galvanized.
 3. **THREADED CONCRETE ANCHORS:** Ferrule loop inserts for 3/8" bolt or approved equal.
 4. **HEADED CONCRETE ANCHORS:** Weld to frame with a full penetration butt weld.
 5. **WELDING:** Weld in conformance with the Standard Specifications. Unless otherwise indicated seal weld all joints with a minimum size fillet weld, based on material thickness. Grind smooth all contact surfaces. **FINISH:** Galvanized after fabrication.
 6. **Estimated weight, frame and grate (2'-6" x 2'-6")** 215 lbs. Increase or decrease weight by 28 lbs for each 4 1/2" increment.
 7. **Number of plates varies according to pipe diameter.** See Standard 604-1.
 8. See Standard 604-1 for dimensions of T.

U.S. DEPARTMENT OF TRANSPORTATION FEDERAL HIGHWAY ADMINISTRATION FEDERAL LANDS HIGHWAY	
U.S. CUSTOMARY STANDARD	
METAL FRAME AND GRATE TYPE A	
STANDARD APPROVED FOR USE 6/2005	STANDARD 604-2
REVISED:	

NO SCALE

01-Nov-2007 11:33 AM
 Rpt://198.145.186.2/std.pln/est60402.dgn [US Customary]

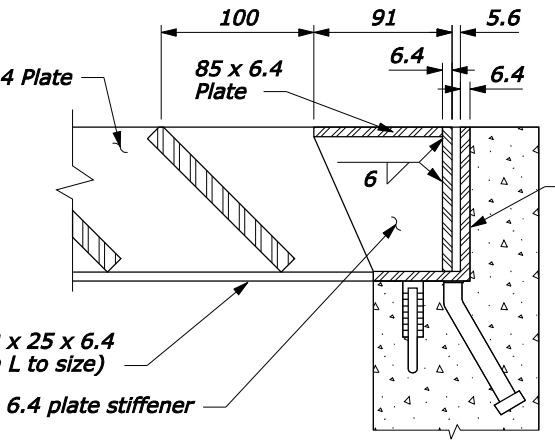
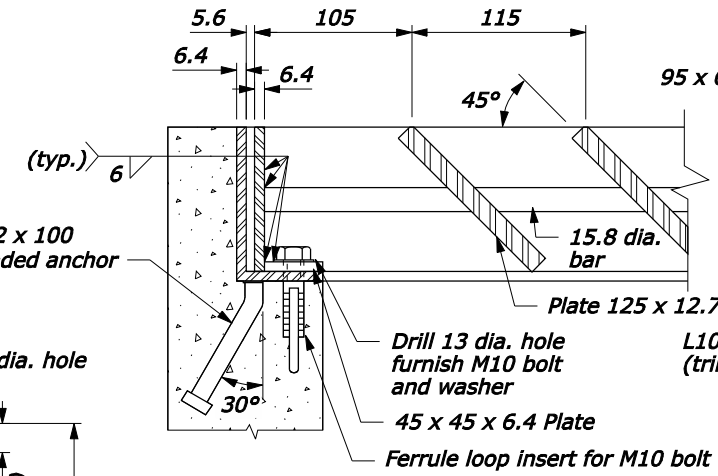
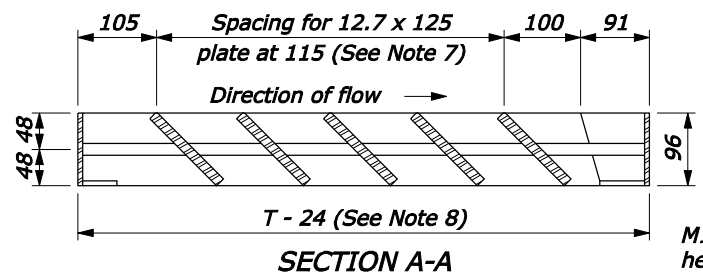

- NOTE:**
1. STRUCTURAL STEEL: AASHTO M 183 (ASTM A 36M).
 2. BOLTS & WASHERS: ASTM A 307, Galvanized.
 3. THREADED CONCRETE ANCHORS: Ferrule loop inserts for M10 bolt or approved equal.
 4. HEADED CONCRETE ANCHORS: Weld to frame with a full penetration butt weld.
 5. WELDING: Weld in conformance with the Standard Specifications. Unless otherwise indicated seal weld all joints with a minimum size fillet weld, based on material thickness. Grind smooth all contact surfaces. FINISH: Galvanized after fabrication.
 6. Estimated weight, frame and grate (756 x 756) 97.5 kg. Increase or decrease weight by 12.7 kg for each 115 increment.
 7. Number of plates varies according to pipe diameter. See Standard M604-1.
 8. See Standard M604-1 for dimensions of T.
 9. Furnish hardware in the metric sizes shown. Equivalent US Customary sizes may be used when metric sizes are unavailable.
 10. Dimensions without units are millimeters.

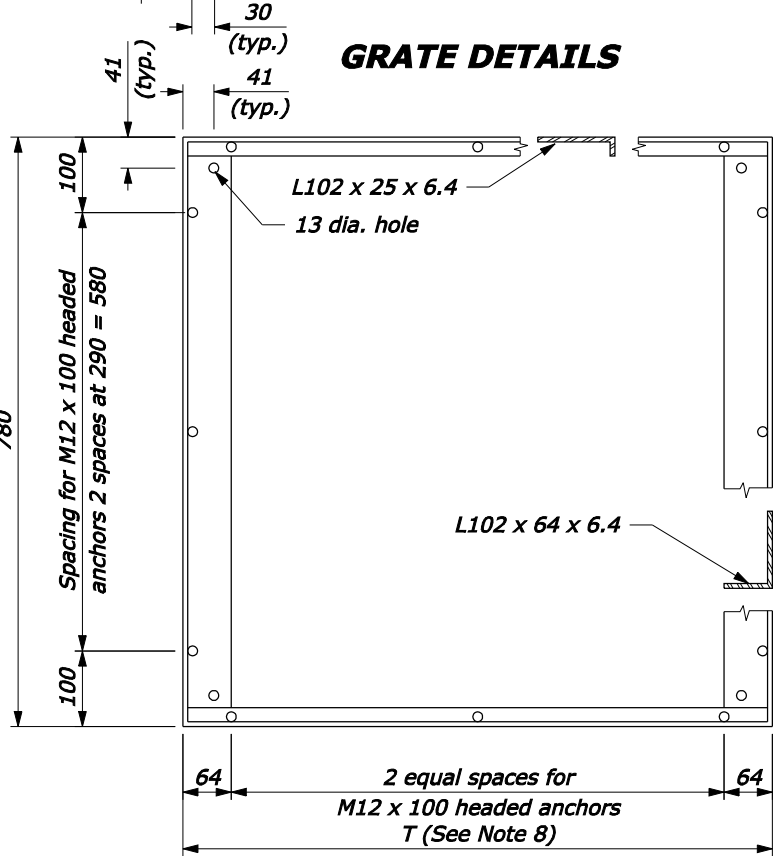
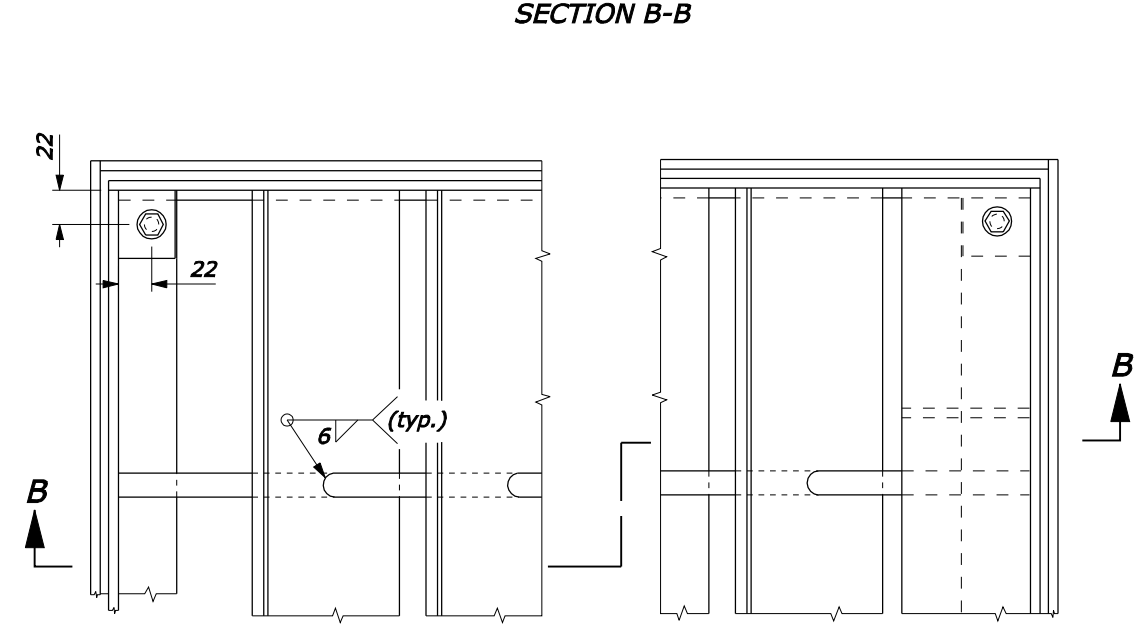
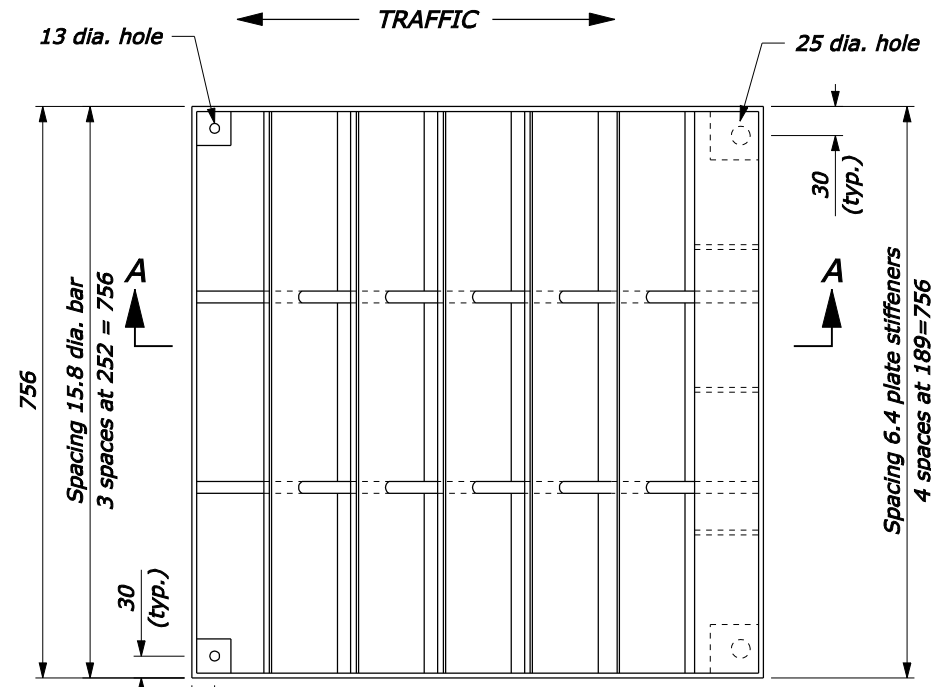

GRATE DETAILS

FRAME AND GRATE DETAILS

FRAME DETAIL

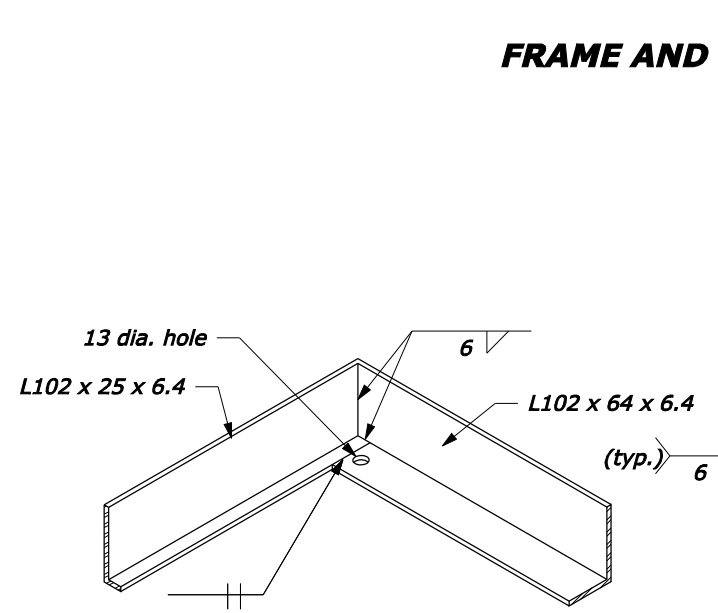

FRAME CORNER DETAIL

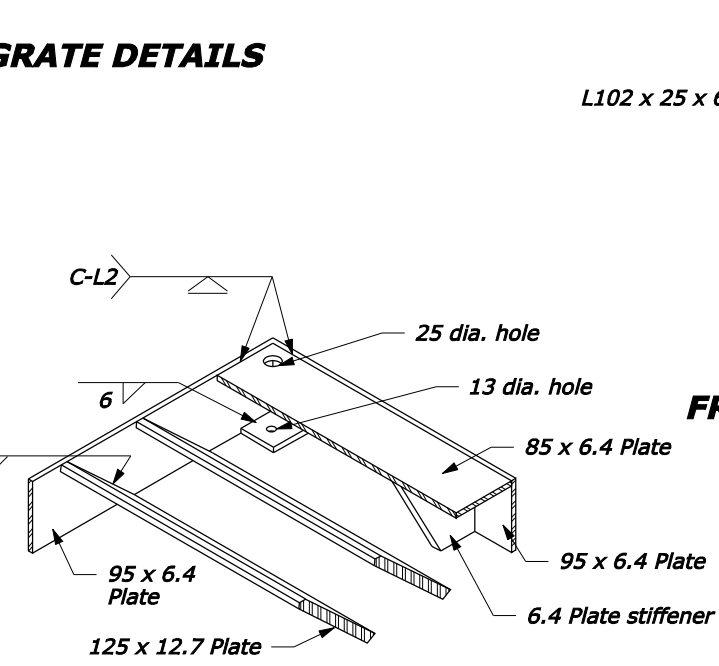

GRATE CORNER DETAIL

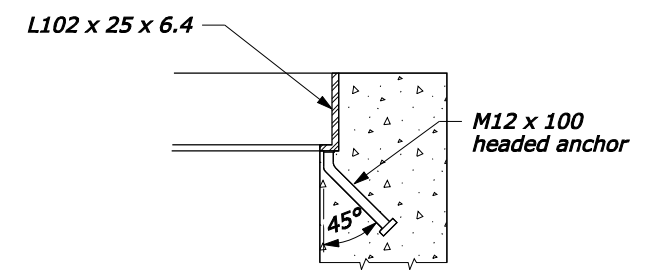

FRAME ANCHOR DETAIL

U.S. DEPARTMENT OF TRANSPORTATION
FEDERAL HIGHWAY ADMINISTRATION
FEDERAL LANDS HIGHWAY
METRIC STANDARD

**METAL FRAME AND GRATE
TYPE A**

STANDARD APPROVED FOR USE 3/1996
REVISED: 8/1997 6/2005

STANDARD
M604-2

NO SCALE

01-Nov-2007 11:32 AM
fp://196.145.188.2/sxd_plan/ss60402.dgn [Metric]

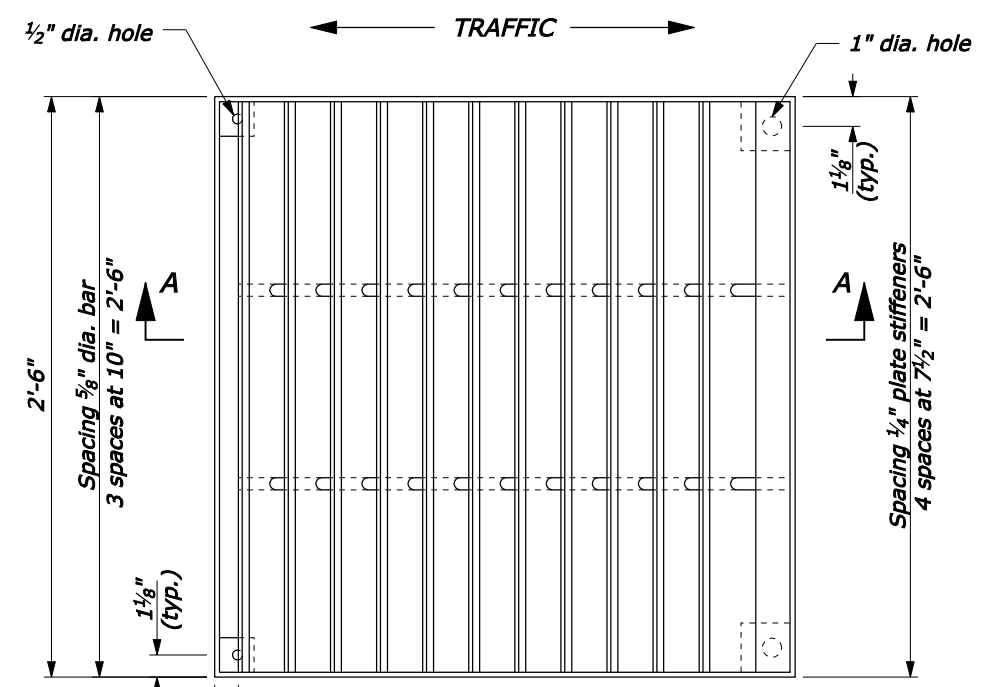
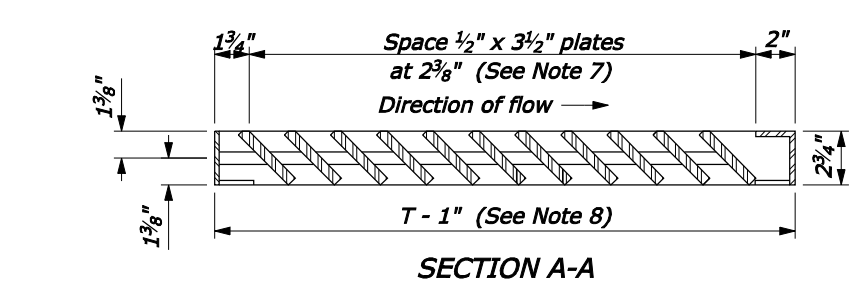

GRATE DETAILS

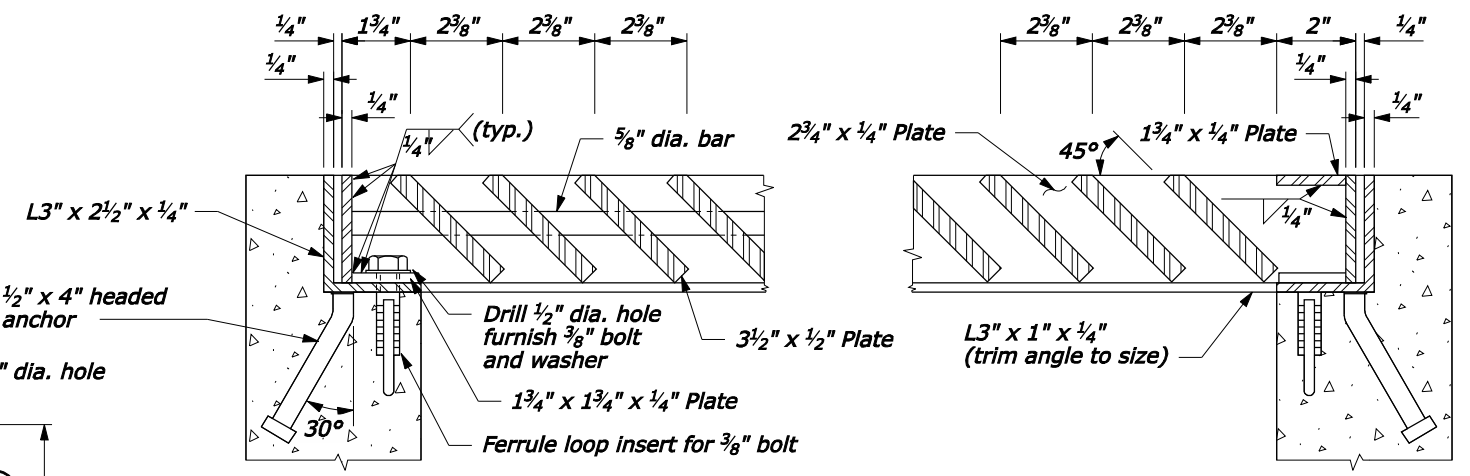
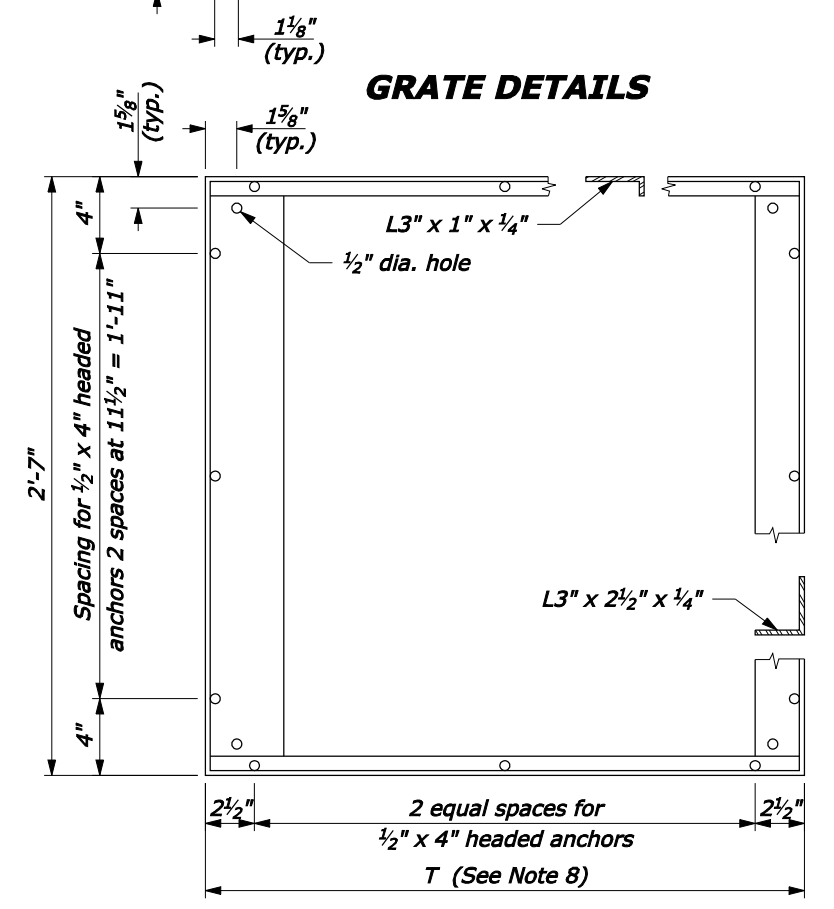

SECTION B-B

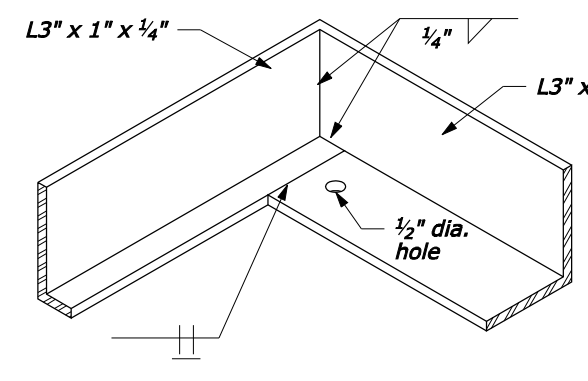
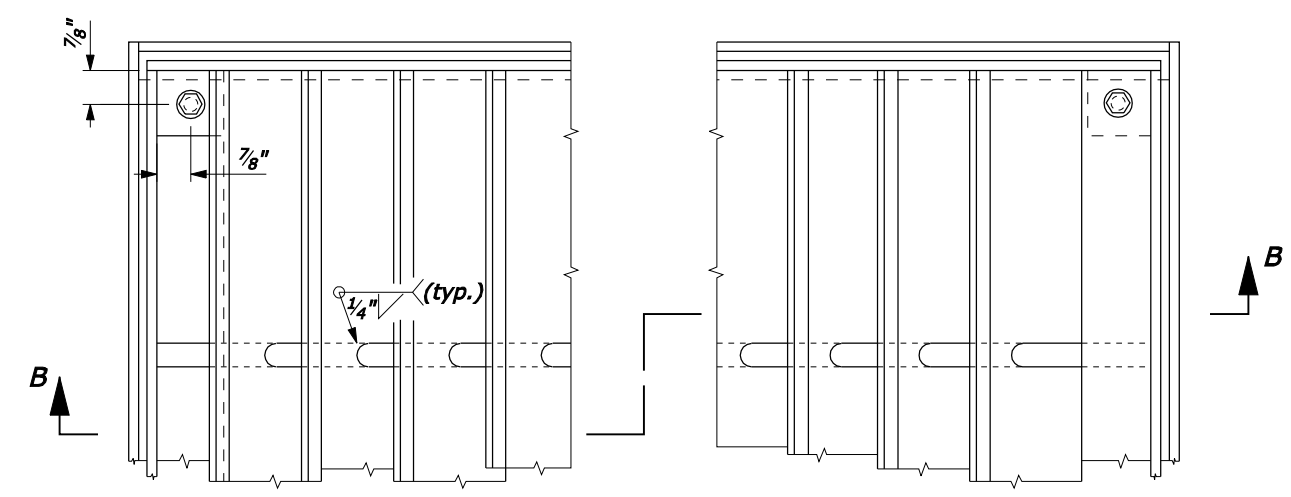

FRAME CORNER DETAIL

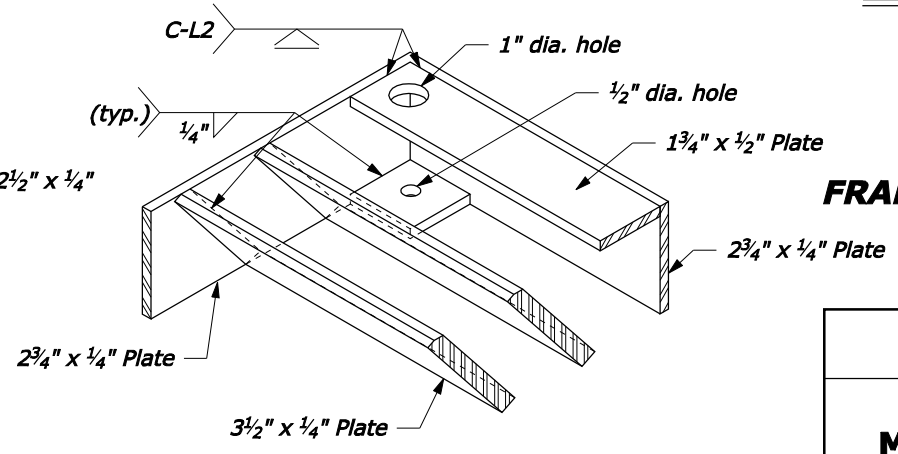

GRATE CORNER DETAIL NO SCALE

NOTE:

1. **STRUCTURAL STEEL:** AASHTO M 183 (ASTM A 36M).
2. **BOLTS & WASHERS:** ASTM A 307, Galvanized.
3. **THREADED CONCRETE ANCHORS:** Ferrule loop inserts for $\frac{3}{8}$ " bolt or approved equal.
4. **HEADED CONCRETE ANCHORS:** Weld to frame with a full penetration butt weld.
5. **WELDING:** Weld in conformance with the Standard Specifications. Unless otherwise indicated seal weld all joints with a minimum size fillet weld, based on material thickness. Grind smooth all contact surfaces. **FINISH:** Galvanized after fabrication.
6. Estimated weight, frame and grate ($2'-6"$ x $2'-6"$) 238 lbs. Increase or decrease weight by 19 lbs for each $2\frac{3}{8}"$ increment.
7. Number of plates varies according to pipe diameter. See Standard 604-1.
8. See Standard 604-1 for dimensions of T.

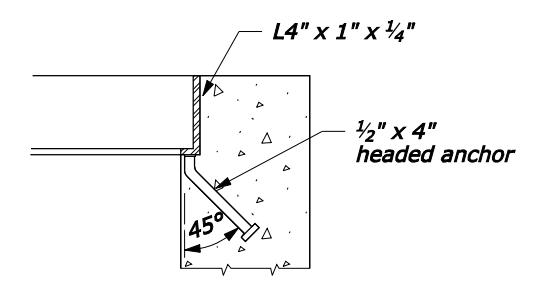

FRAME ANCHOR DETAIL

U.S. DEPARTMENT OF TRANSPORTATION FEDERAL HIGHWAY ADMINISTRATION FEDERAL LANDS HIGHWAY	
U.S. CUSTOMARY STANDARD	
METAL FRAME AND GRATE TYPE B	
STANDARD APPROVED FOR USE 6/2005 REVISED: 6/2007	STANDARD 604-3

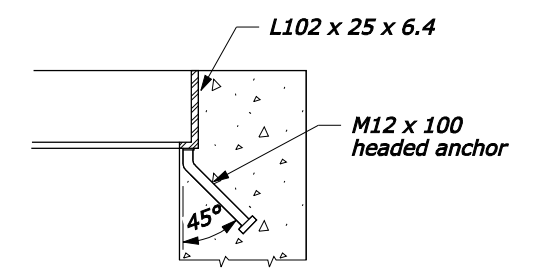
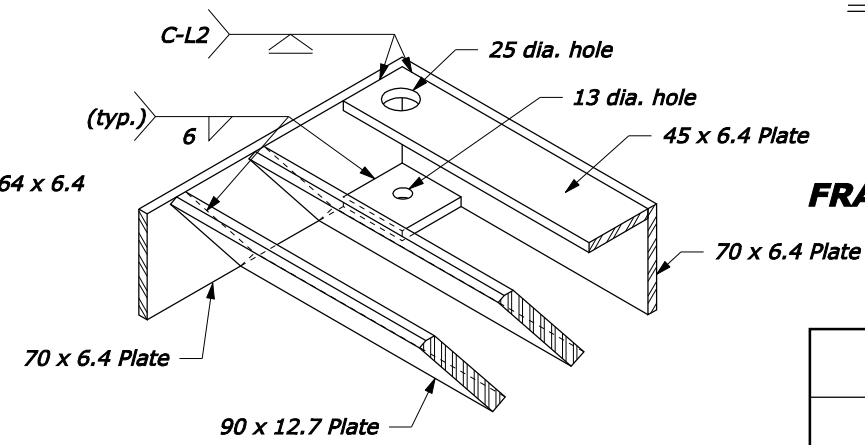
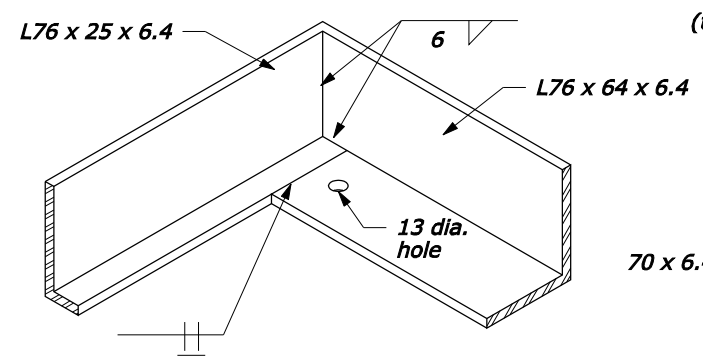
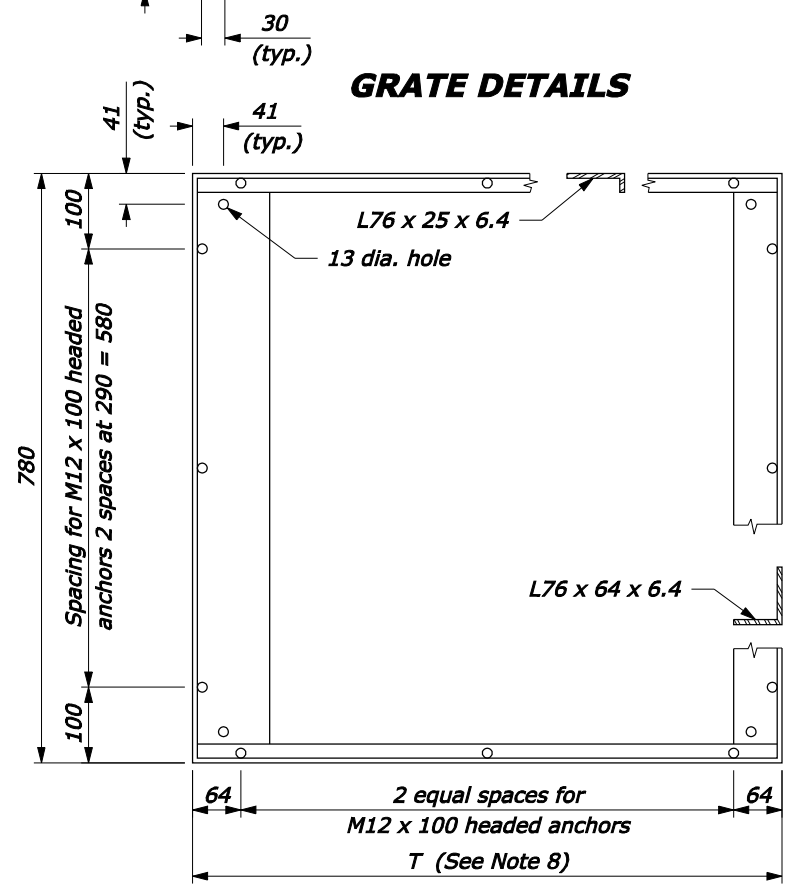
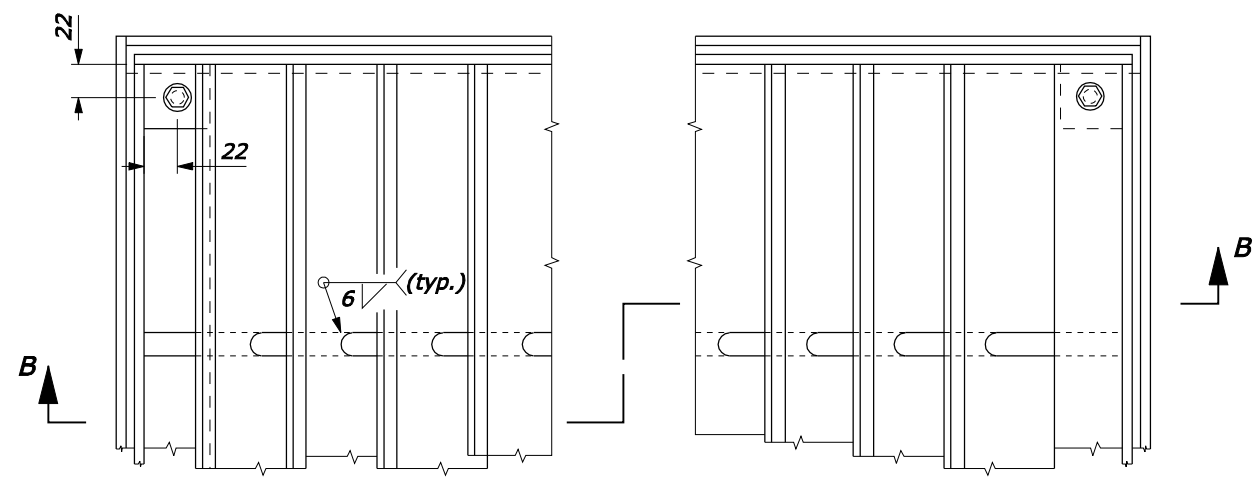
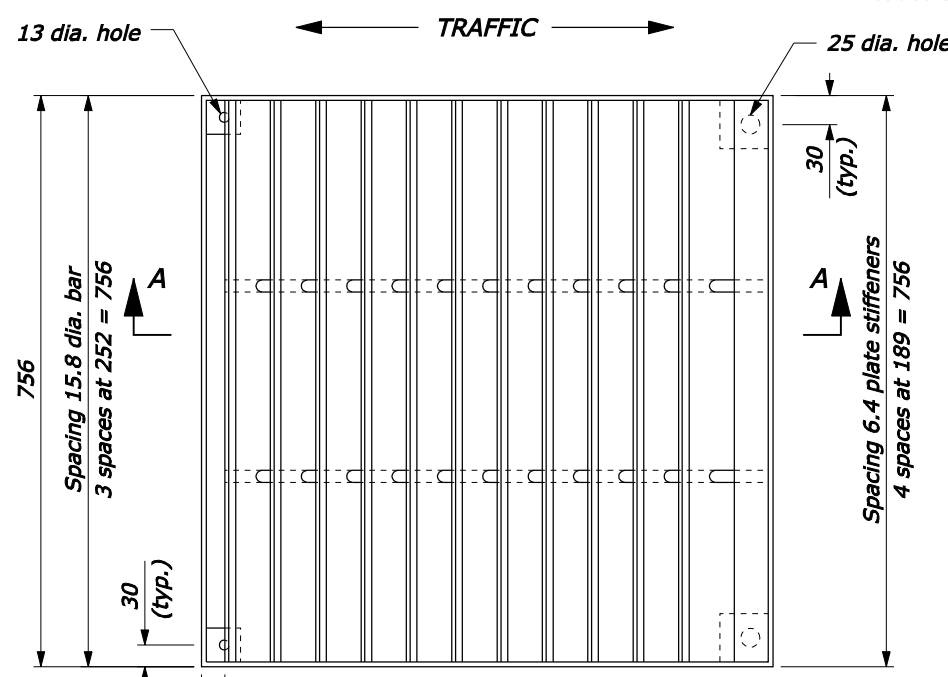
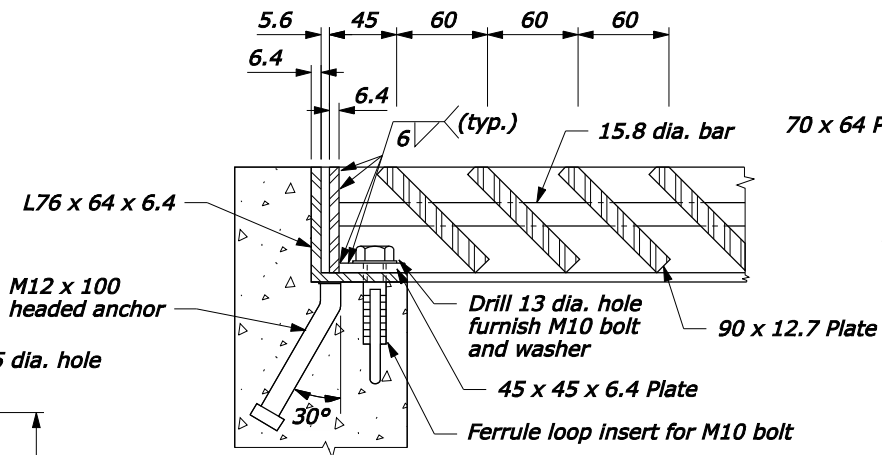
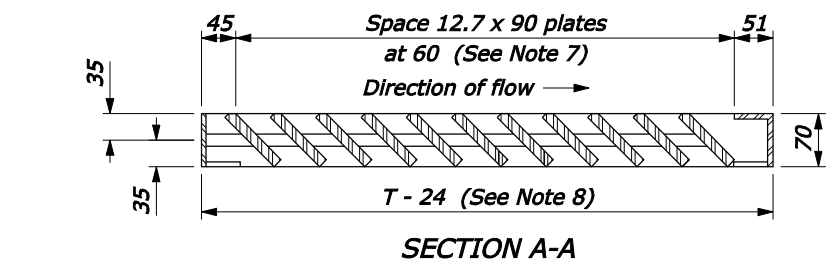

- NOTE:**
- STRUCTURAL STEEL: AASHTO M 183 (ASTM A 36M).
 - BOLTS & WASHERS: ASTM A 307, Galvanized.
 - THREADED CONCRETE ANCHORS: Ferrule loop inserts for M10 bolt or approved equal.
 - HEADED CONCRETE ANCHORS: Weld to frame with a full penetration butt weld.
 - WELDING: Weld in conformance with the Standard Specifications. Unless otherwise indicated seal weld all joints with a minimum size fillet weld, based on material thickness. Grind smooth all contact surfaces. FINISH: Galvanized after fabrication.
 - Estimated weight, frame and grate (756 x 756 mm) 108 kg. Increase or decrease weight by 8.6 kg for each 60 mm increment.
 - Number of plates varies according to pipe diameter. See Standard M604-1.
 - See Standard M604-1 for dimensions of T.
 - Furnish hardware in the metric sizes shown. Equivalent US Customary sizes may be used when metric sizes are unavailable.
 - Dimensions without units are millimeters.

U.S. DEPARTMENT OF TRANSPORTATION
 FEDERAL HIGHWAY ADMINISTRATION
 FEDERAL LANDS HIGHWAY
 METRIC STANDARD

**METAL FRAME AND GRATE
 TYPE B**

STANDARD APPROVED FOR USE 3/1996
 REVISED: 8/1997 6/2005

STANDARD
 M604-3

01-Nov-2007 11:03 AM
 fp://196.145.188.2/scl_plan/s60403.dgn [Metric]

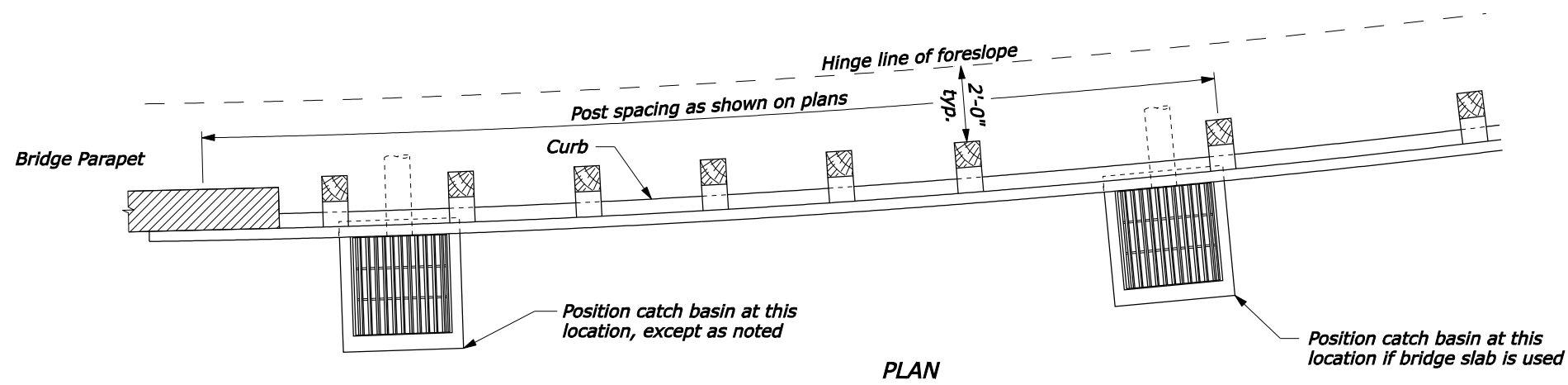

PLAN
CATCH BASIN LAYOUT AT BRIDGE ENDS

NOTE:

1. **CONCRETE:** Chamfer exposed edges $\frac{3}{4}$ " unless otherwise shown. Give all concrete surfaces a Class 1 finish.
2. The minimum concrete cover to the face of any bar is $1\frac{1}{2}$ " unless otherwise shown.
3. See Standard 604-2 for Type A Frame and Grate and Standard 604-3 for Type B Frame and Grate.
4. Make all coupling band connections watertight by placing $\frac{3}{16}$ " bead of approved caulking under each half of the bands before tightening.
5. Fabricate tapered portion of slip-joint from either flat or corrugated sheets.
6. Place Class 2 riprap conforming to Section 251 for protective apron.

DESCRIPTION	FRAME AND GRATE	
	TYPE A	TYPE B
Reinforcing Steel	70 lb	70 lb
Structural Steel	215 lb	238 lb
Concrete	0.85 cu yd	0.85 cu yd

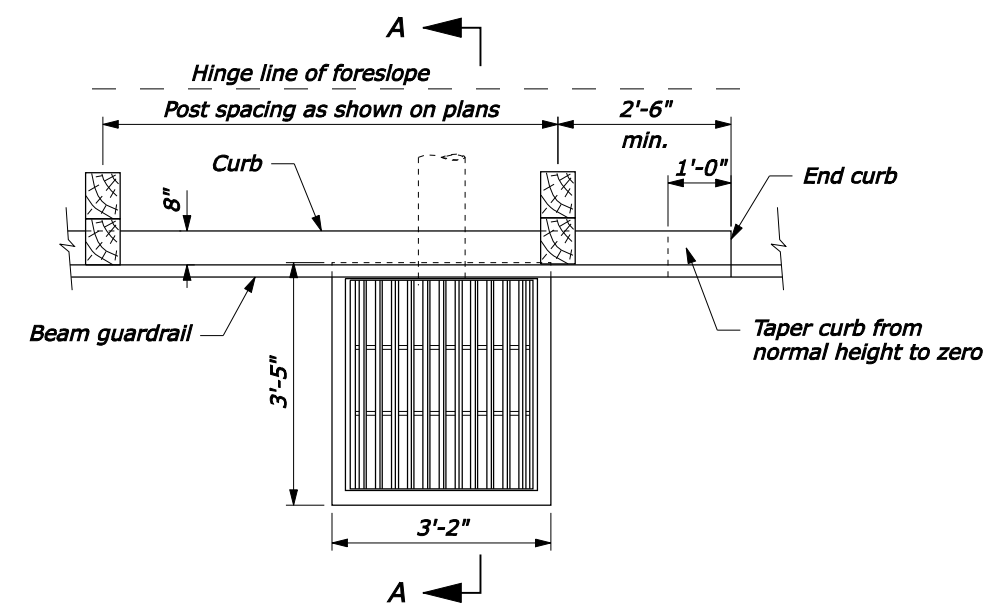

CATCH BASIN LAYOUT

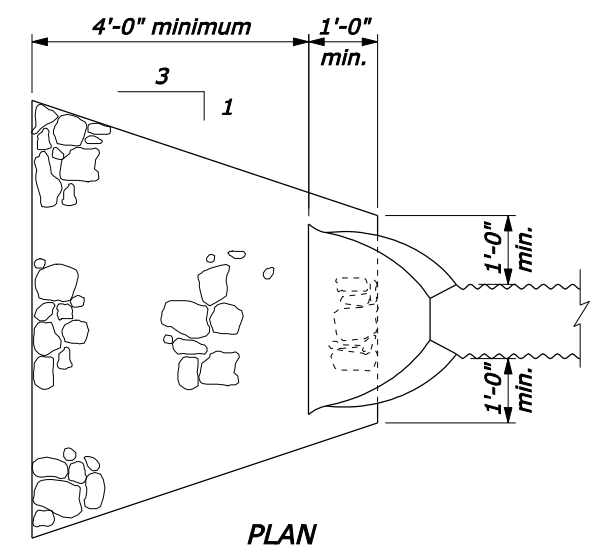

PLAN
PROTECTIVE APRON

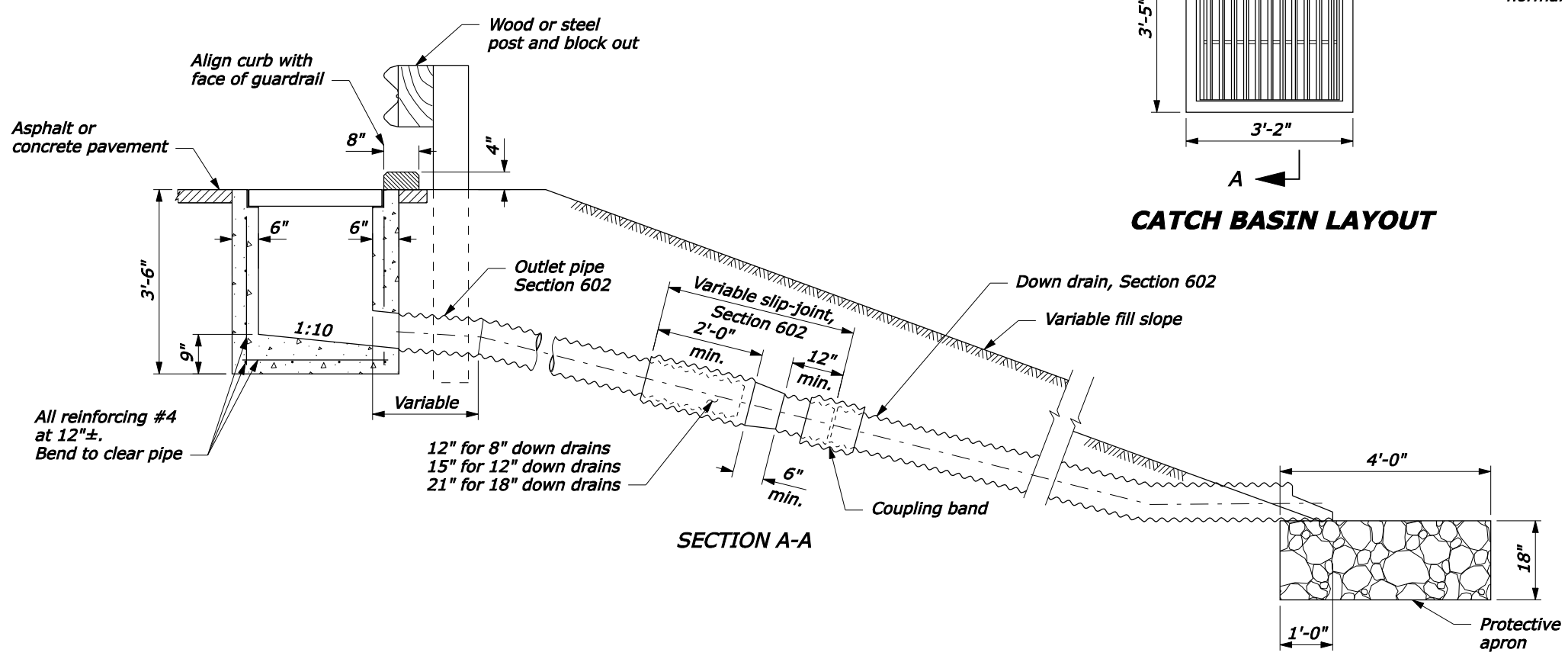

SECTION A-A

NO SCALE

U.S. DEPARTMENT OF TRANSPORTATION FEDERAL HIGHWAY ADMINISTRATION FEDERAL LANDS HIGHWAY	
U.S. CUSTOMARY STANDARD CATCH BASIN TYPE 2 WITH DOWN DRAIN	
STANDARD APPROVED FOR USE 6/2005	STANDARD 604-4
REVISED:	

01-Nov-2007 09:14 PM
 P:\198.145.186.2\std. plan\std604.dgn [US Customary]

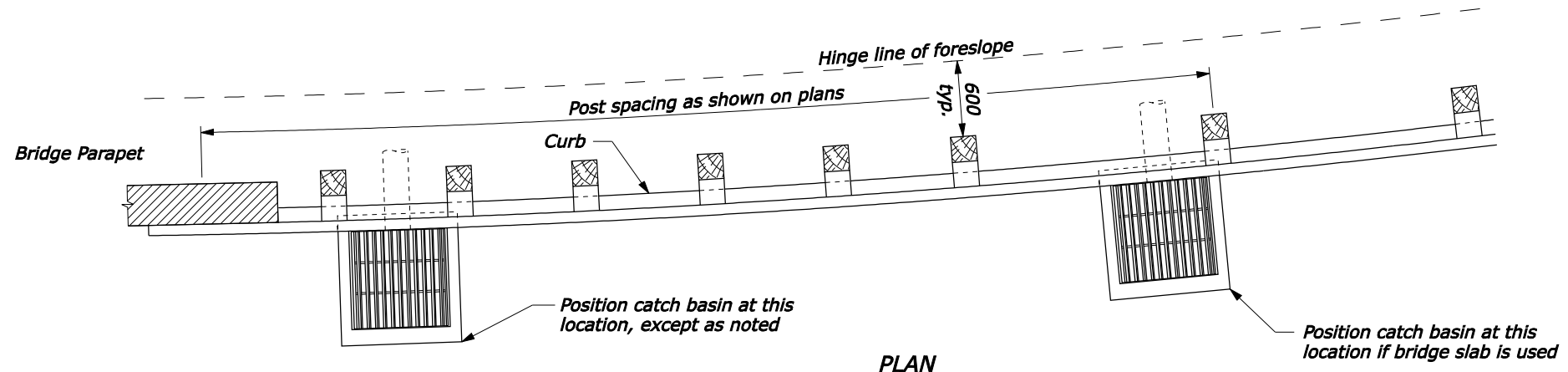

PLAN
CATCH BASIN LAYOUT AT BRIDGE ENDS

NOTE:

1. **CONCRETE:** Chamfer exposed edges 20 mm unless otherwise shown. Give all concrete surfaces a Class 1 finish.
2. The minimum concrete cover to the face of any bar is 50 mm unless otherwise shown.
3. See Standard M604-2 for Type A Frame and Grate and Standard M604-3 for Type B Frame and Grate.
4. Make all coupling band connections watertight by placing 5 mm bead of approved caulking under each half of the bands before tightening.
5. Fabricate tapered portion of slip-joint from either flat or corrugated sheets.
6. Place Class 2 riprap conforming to Section 251 for protective apron.
7. Dimensions without units are millimeters.

DESCRIPTION	FRAME AND GRATE	
	TYPE A	TYPE B
Reinforcing Steel	32 kg	32 kg
Structural Steel	98 kg	108 kg
Concrete	0.6 m ³	0.6 m ³

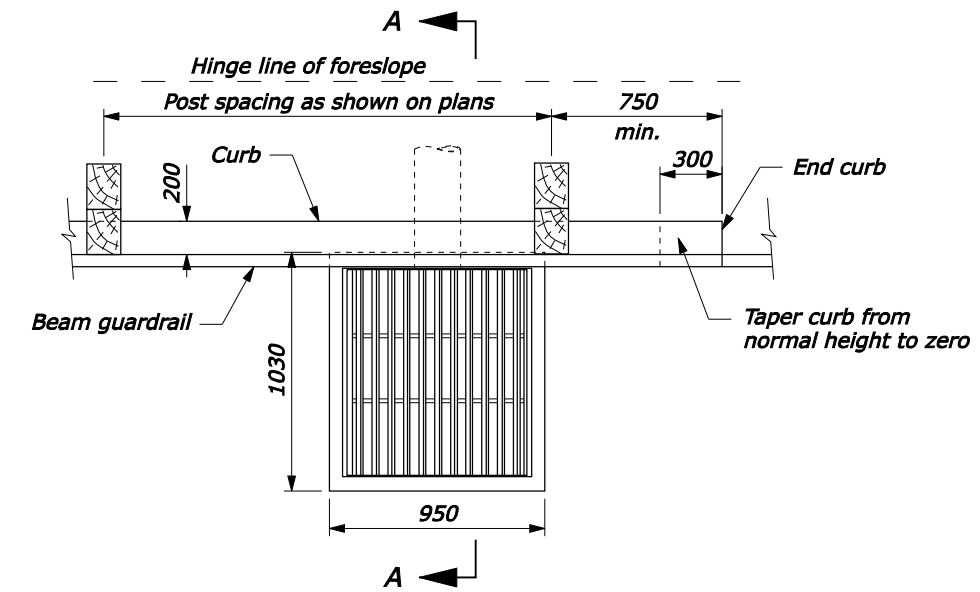

CATCH BASIN LAYOUT

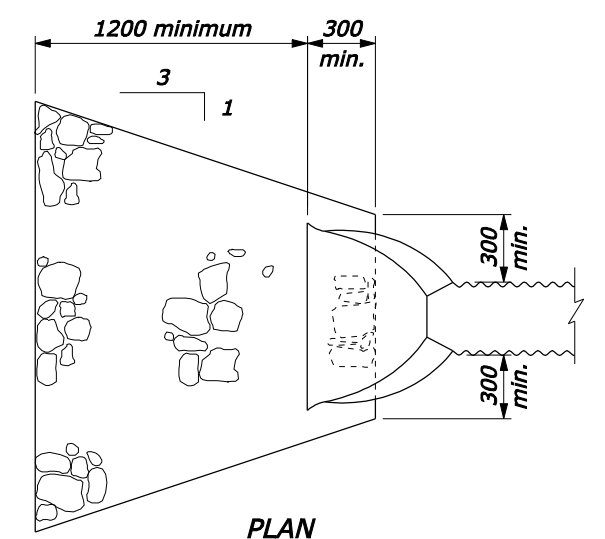

PLAN
PROTECTIVE APRON

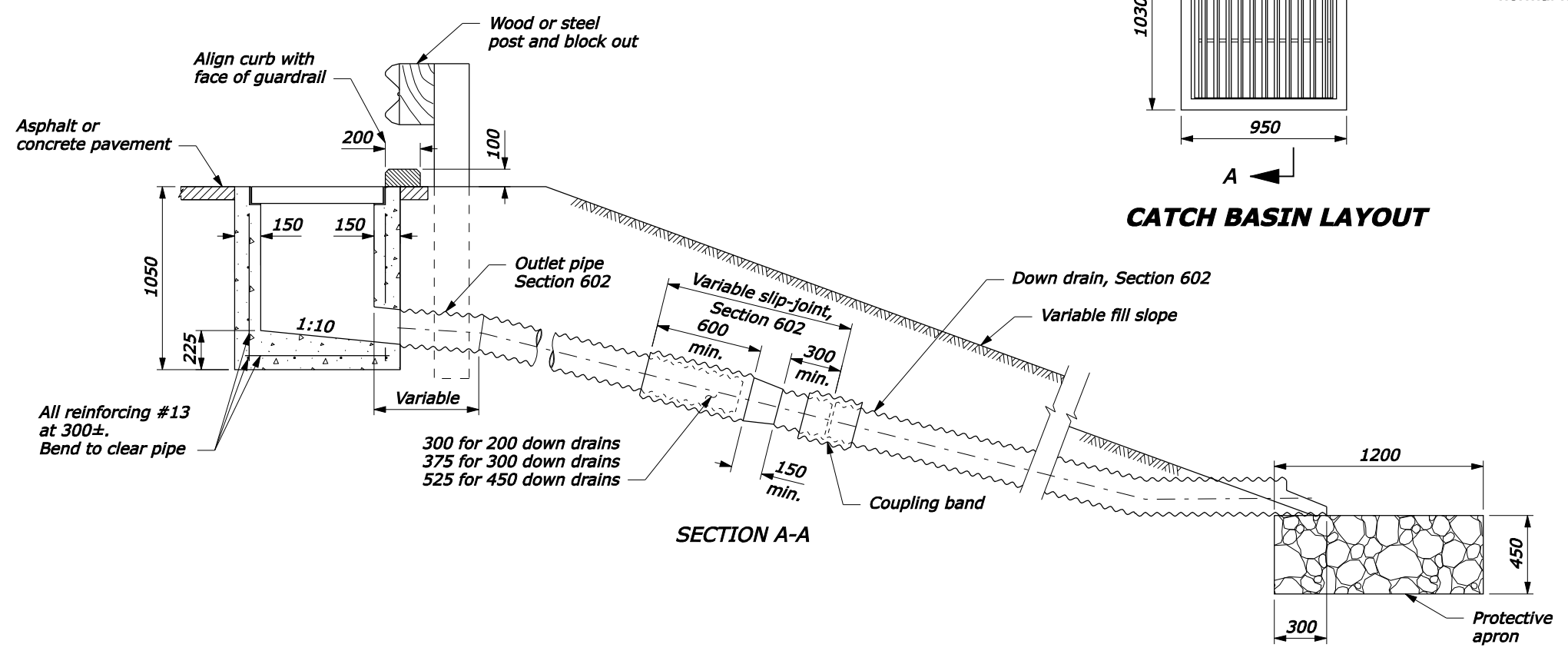

SECTION A-A

NO SCALE

U.S. DEPARTMENT OF TRANSPORTATION FEDERAL HIGHWAY ADMINISTRATION FEDERAL LANDS HIGHWAY METRIC STANDARD CATCH BASIN TYPE 2 WITH DOWN DRAIN	
STANDARD APPROVED FOR USE 3/1996 REVISED: 5/1997 6/2005	STANDARD M604-4

01-Nov-2007 03:14 PM
 ftp://196.145.188.2/scd_plan/ss60404.dgn [Metric]

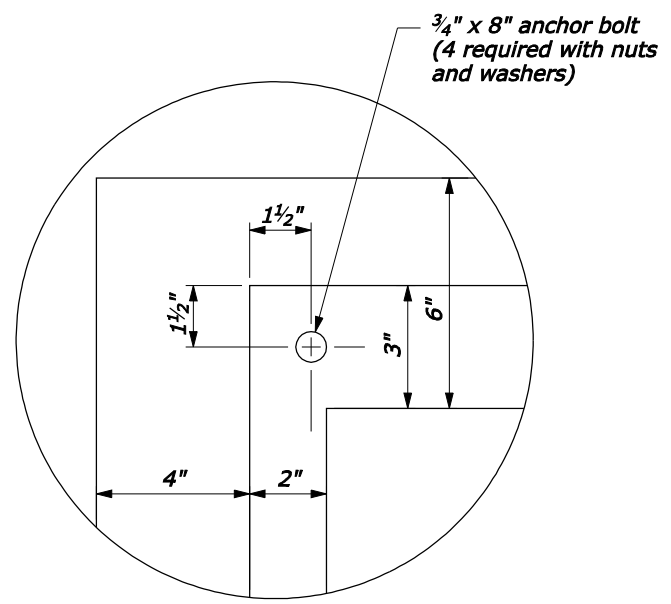

DETAIL A

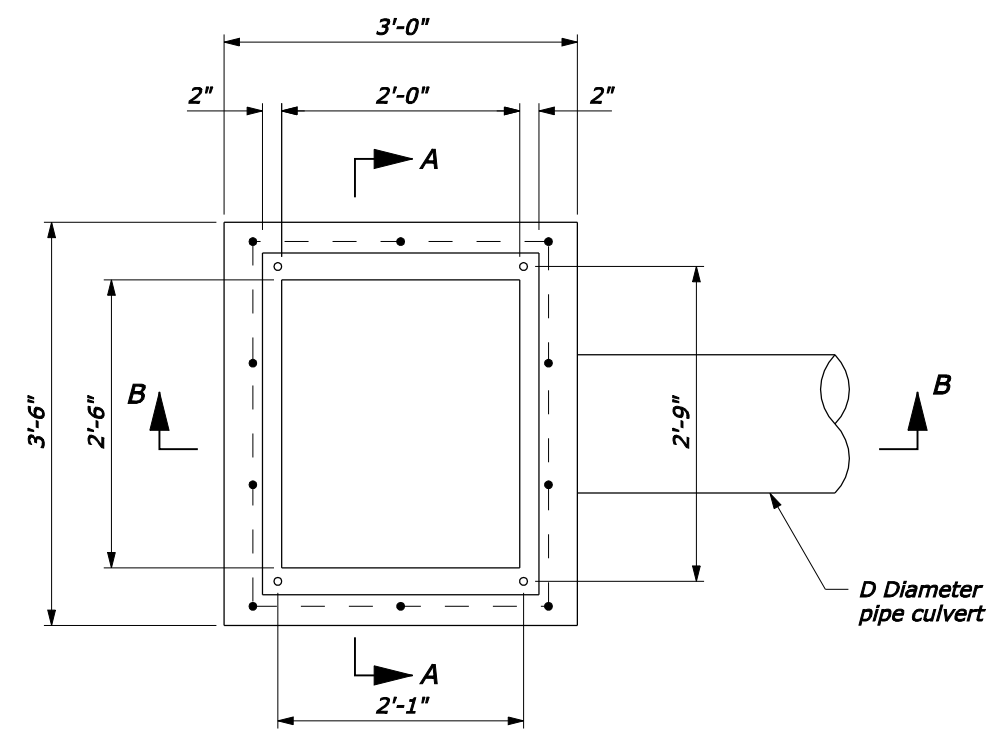

PLAN

NOTE:

1. All reinforcing bars are #5 placed a minimum 1 1/2" clear from face of concrete. In floors, place bars on 6 inch centers each way. In walls, place horizontal bars in 6 inch centers and vertical bars on 12 inch centers.
2. Curb shape shown for illustration only. Actual curb shape and dimensions are shown in the plans.
3. See Standard 604-6 for Frame and Grate Details.
4. If guardrail post location results in guardrail penetrating the culvert, eliminate the post and place additional nested W-beam rail sections per Standard 617-24.

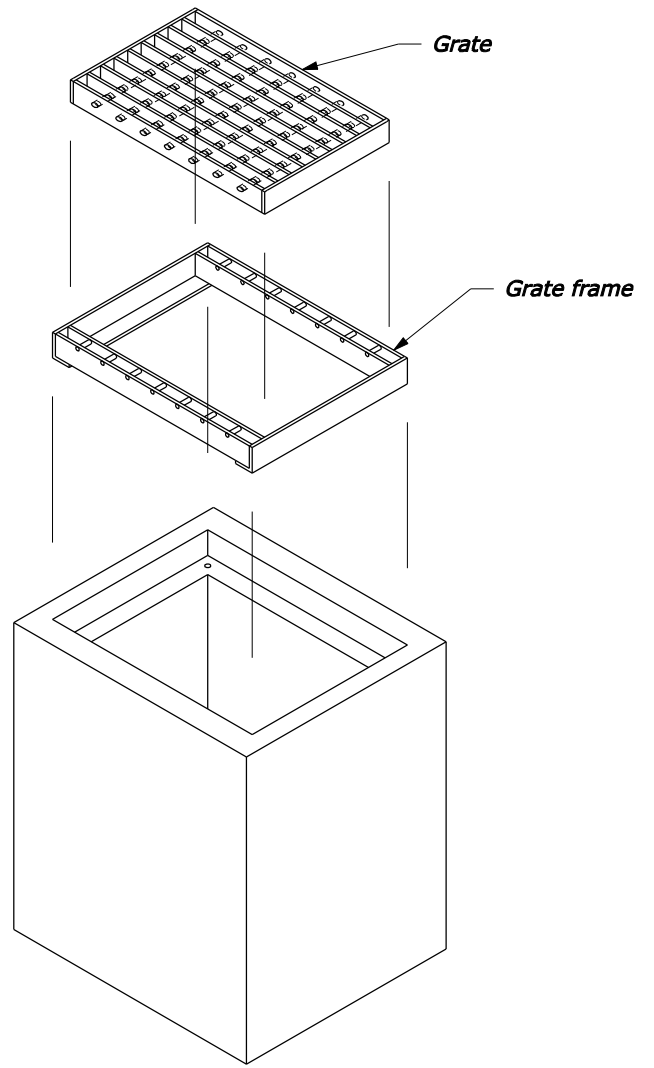

ISOMETRIC VIEW

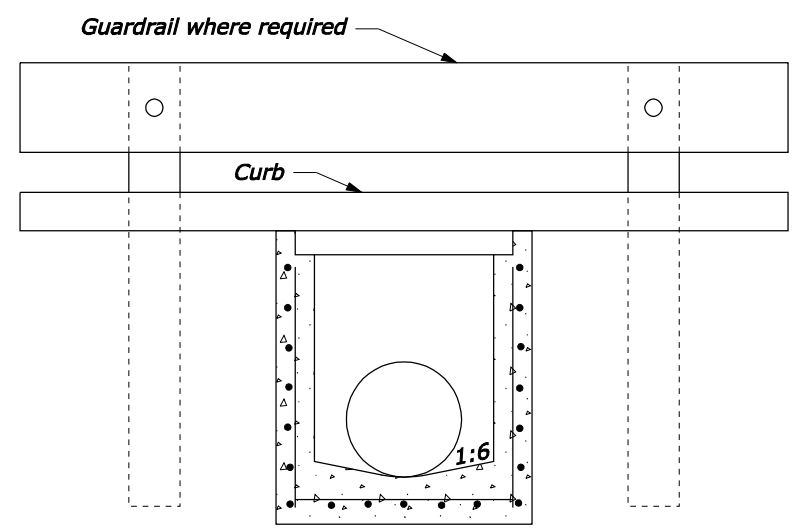

SECTION A-A

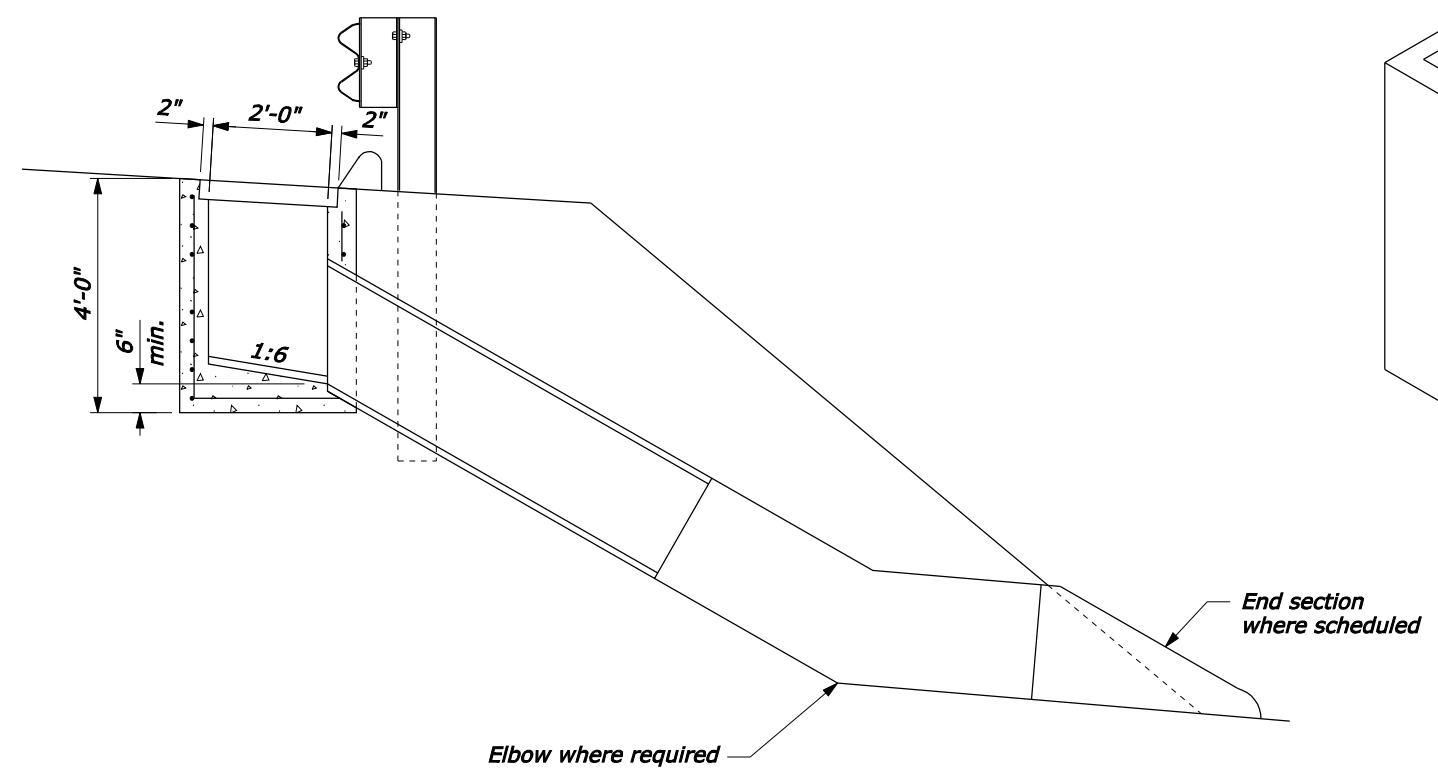

SECTION B-B

NO SCALE

U.S. DEPARTMENT OF TRANSPORTATION FEDERAL HIGHWAY ADMINISTRATION FEDERAL LANDS HIGHWAY	
U.S. CUSTOMARY STANDARD	
INLET TYPE 5A	
STANDARD APPROVED FOR USE 6/2005	STANDARD
REVISED:	604-5

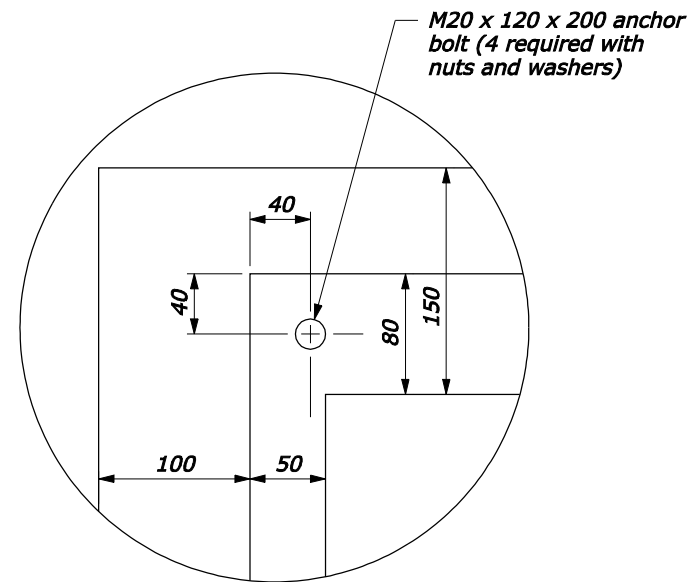

DETAIL A

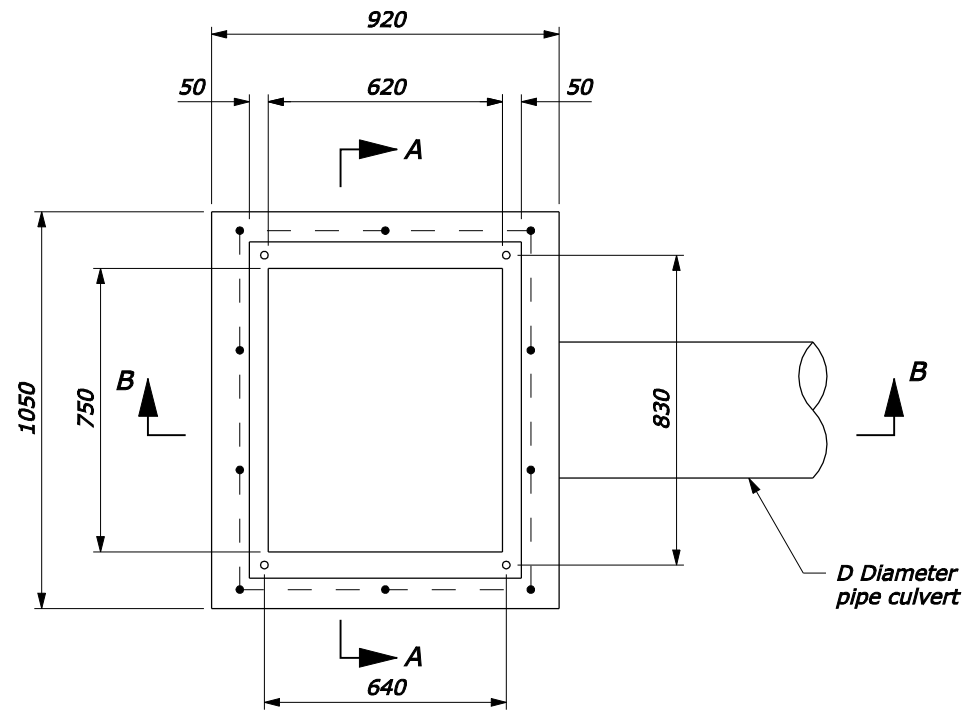

PLAN

NOTE:

1. All reinforcing bars are #16 placed a minimum 40 mm clear from face of concrete. In floors, place bars on 150 mm centers each way. In walls, place horizontal bars in 150 mm centers and vertical bars on 300 mm centers.
2. Curb shape shown for illustration only. Actual curb shape and dimensions are shown in the plans.
3. See Standard M604-6 for Frame and Grate Details.
4. If guardrail post location results in guardrail penetrating the culvert, eliminate the post and place additional nested W-beam rail sections per Standard M617-24.
5. Dimensions without units are millimeters.

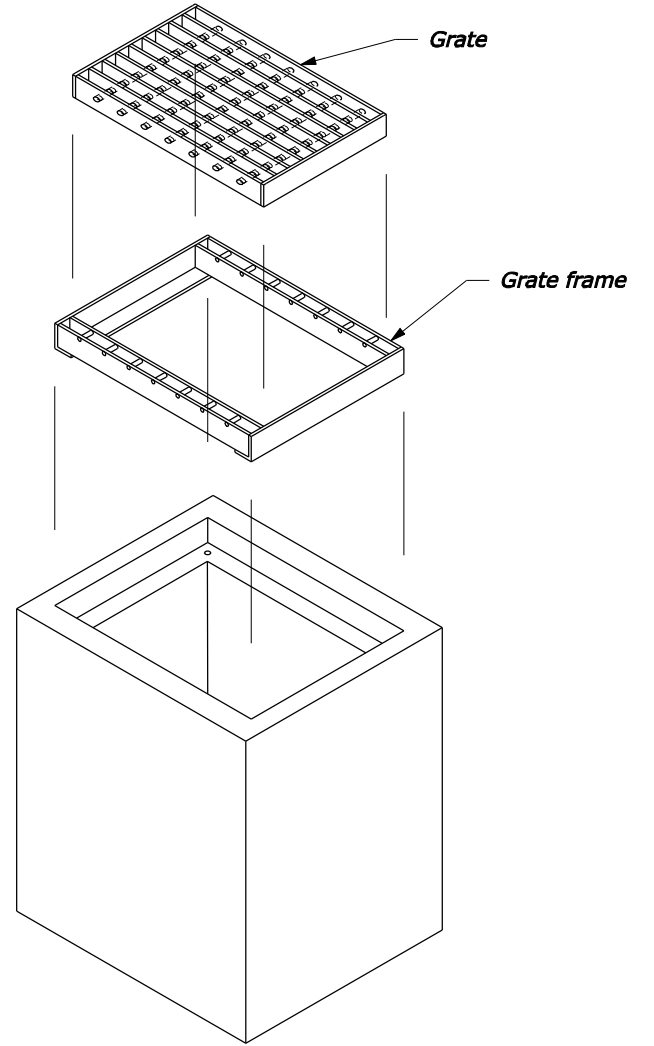

ISOMETRIC VIEW

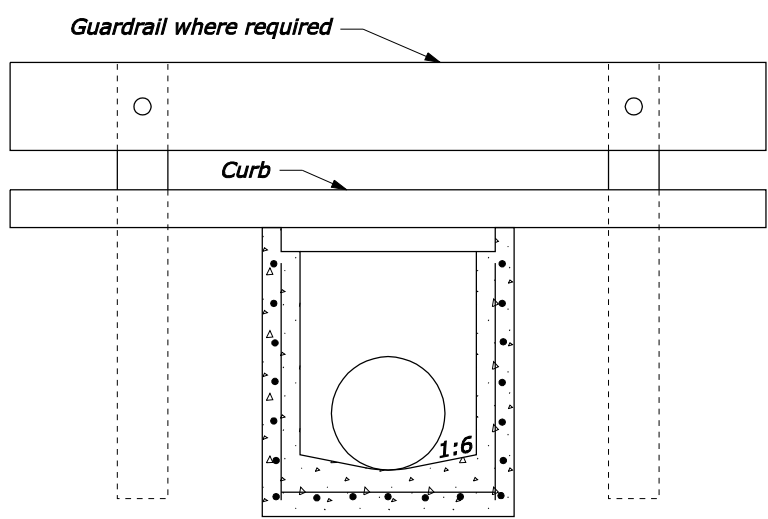

SECTION A-A

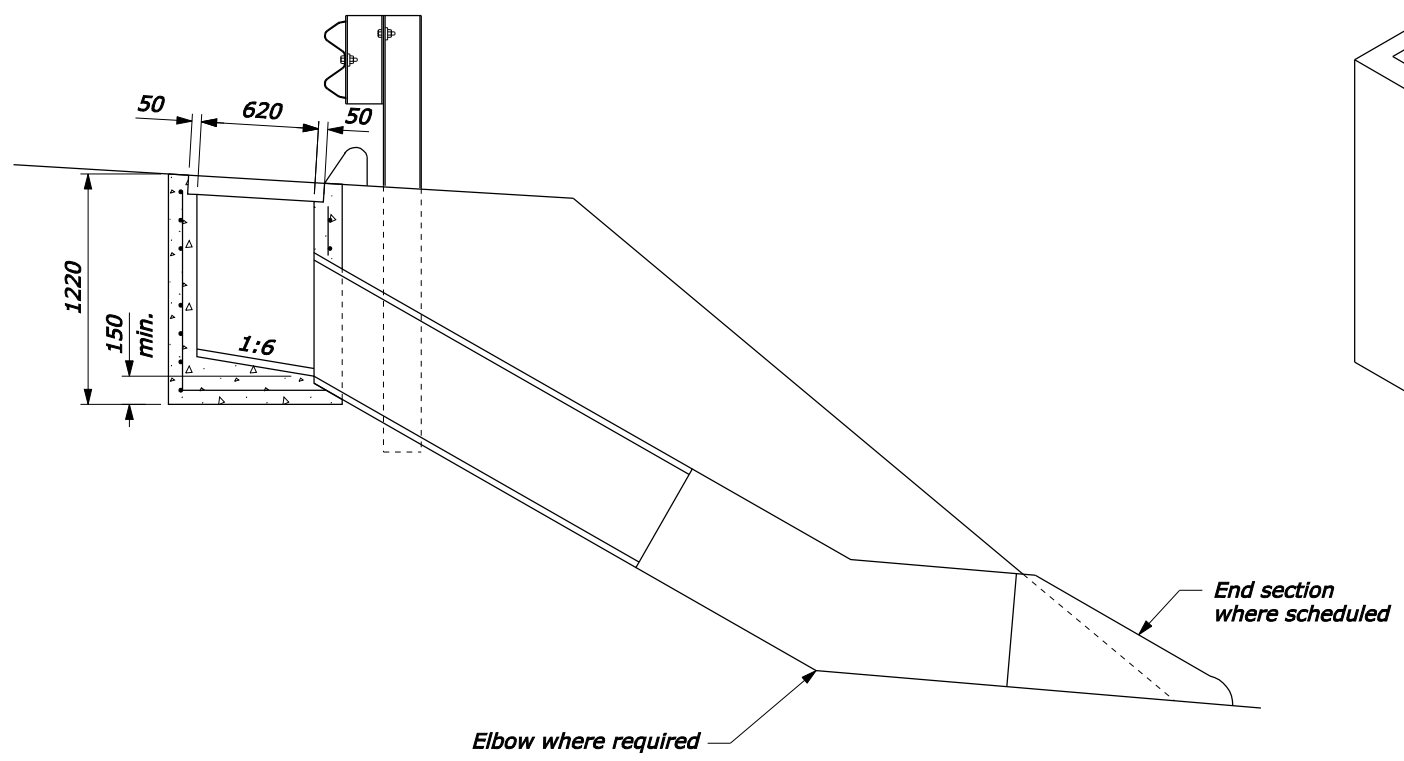

SECTION B-B

NO SCALE

U.S. DEPARTMENT OF TRANSPORTATION FEDERAL HIGHWAY ADMINISTRATION FEDERAL LANDS HIGHWAY	
METRIC STANDARD	
INLET TYPE 5A	
STANDARD APPROVED FOR USE 3/1996	STANDARD
REVISED: 5/1997 6/2005	M604-5

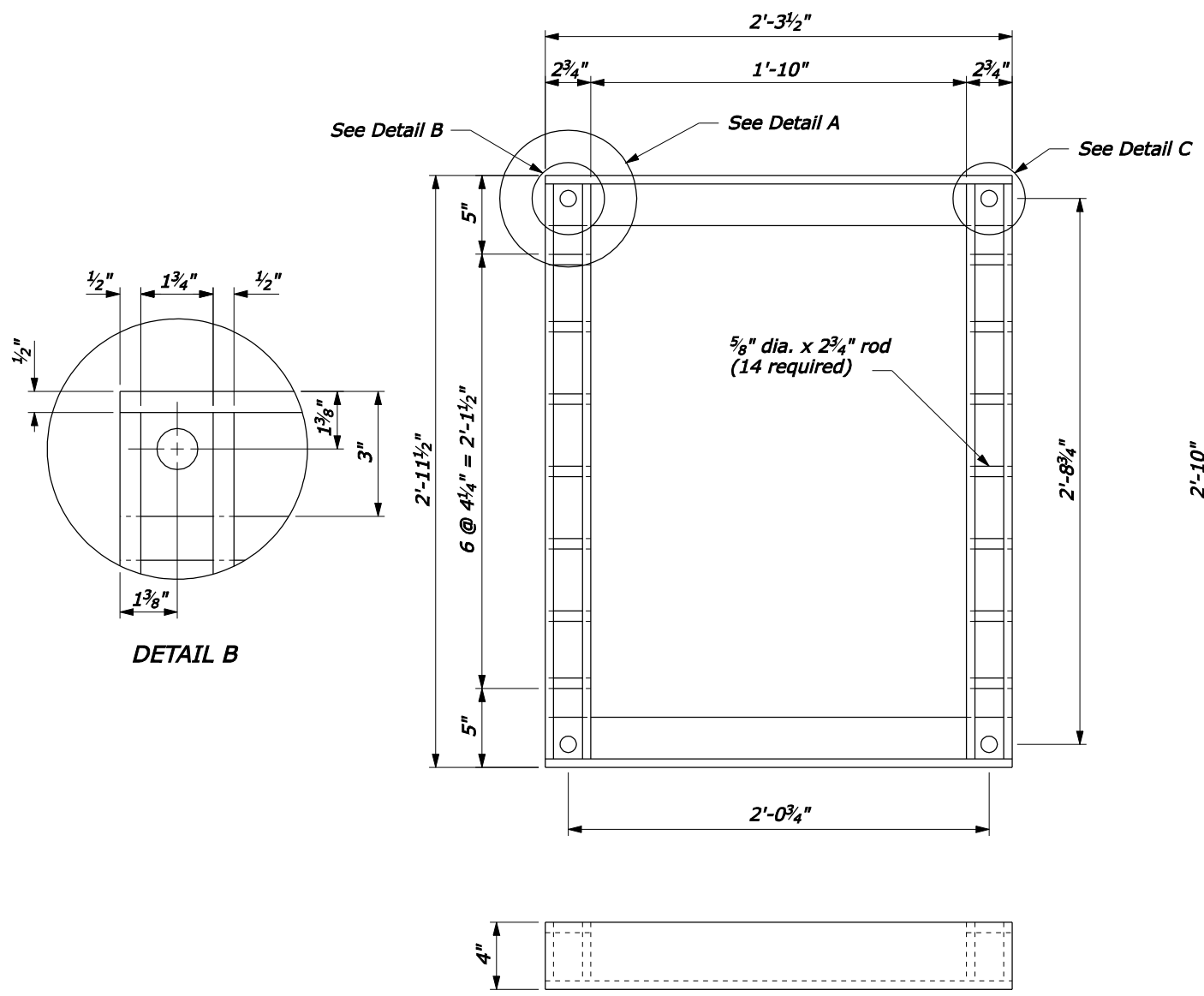

GRATE FRAME

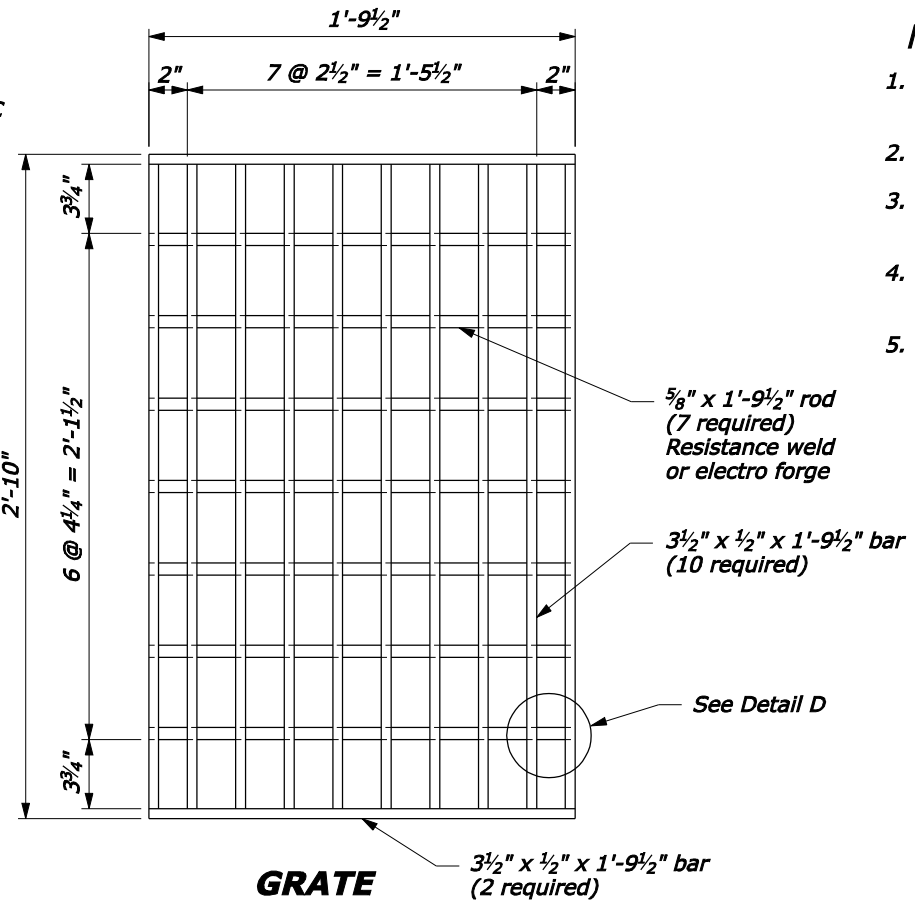

GRATE

NOTE:

1. Hot dip galvanize all metal parts for frame and grate after fabrication.
2. Fabricate frame and grate from structural steel.
3. Furnish four 3/4" x 8" anchor bolts with nuts to attach frame to inlet.
4. Cut holes 3 1/2" x 1/2" bar as required to place 5/8 inch diameter rods.
5. Spot weld 5/8 inch diameter rods for frame and grate to 3 1/2" x 1/2" bars.

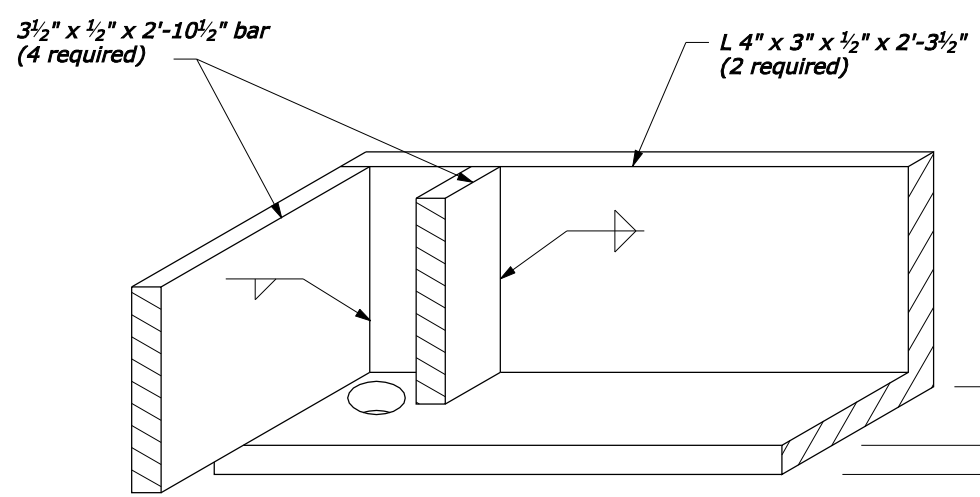
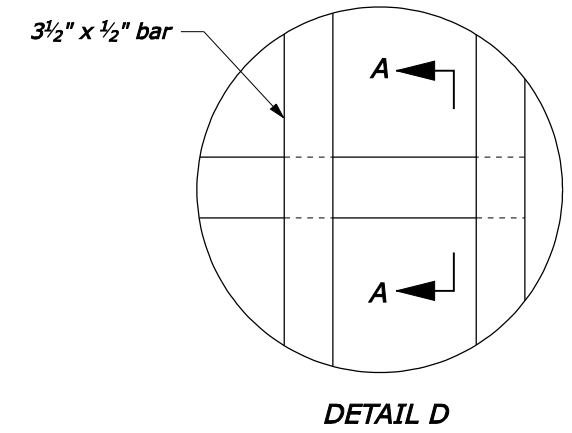
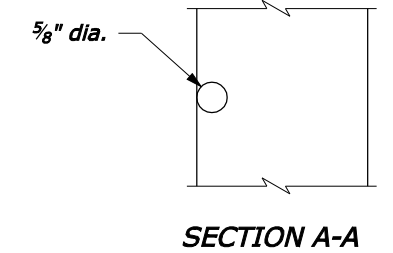
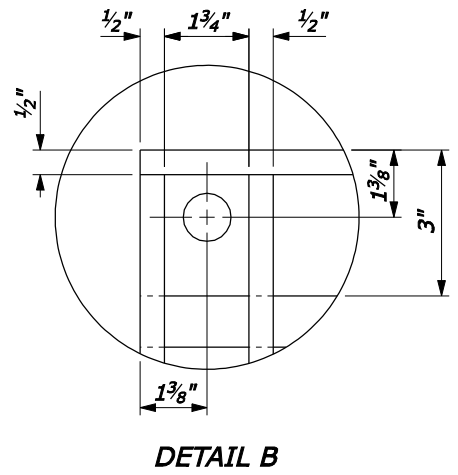

DETAIL A (OBLIQUE)

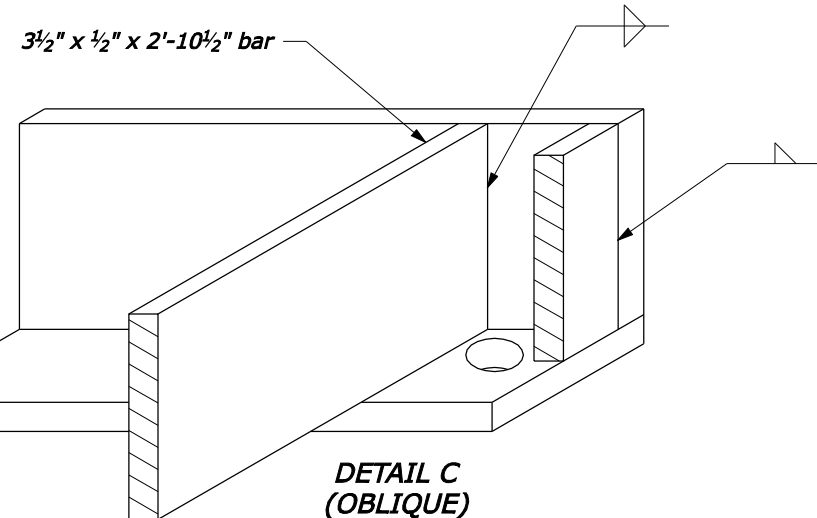

DETAIL C (OBLIQUE)

NO SCALE

U.S. DEPARTMENT OF TRANSPORTATION FEDERAL HIGHWAY ADMINISTRATION FEDERAL LANDS HIGHWAY	
U.S. CUSTOMARY STANDARD	
FRAME AND GRATE TYPE 5A	
STANDARD APPROVED FOR USE 6/2005	STANDARD
REVISED:	604-6

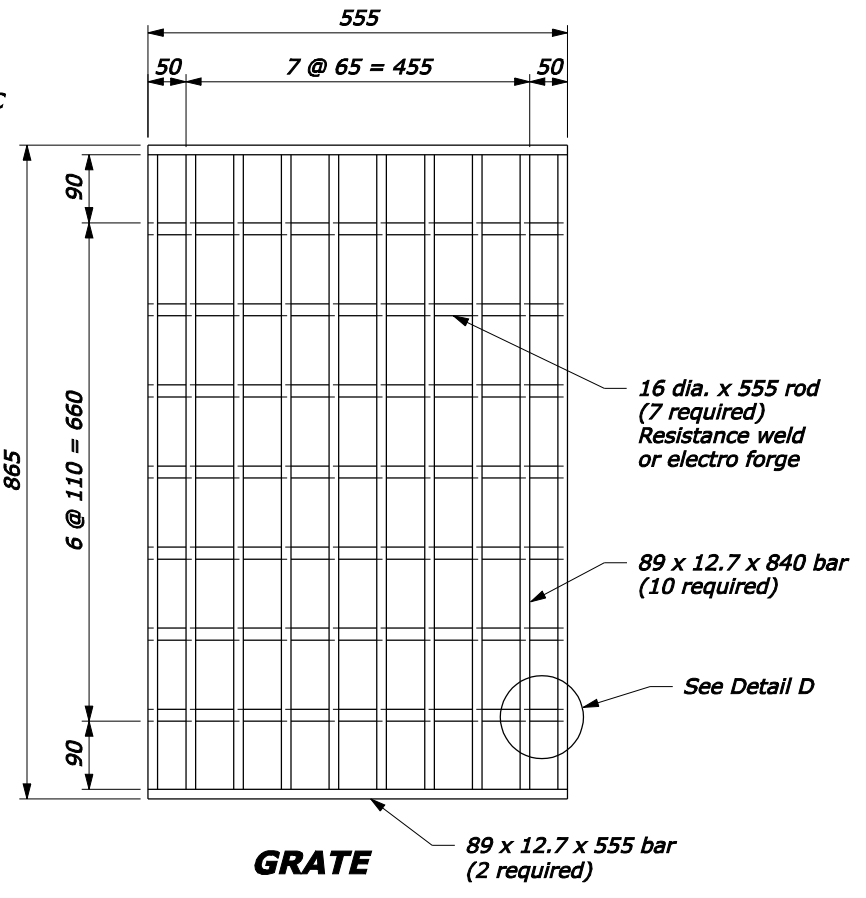
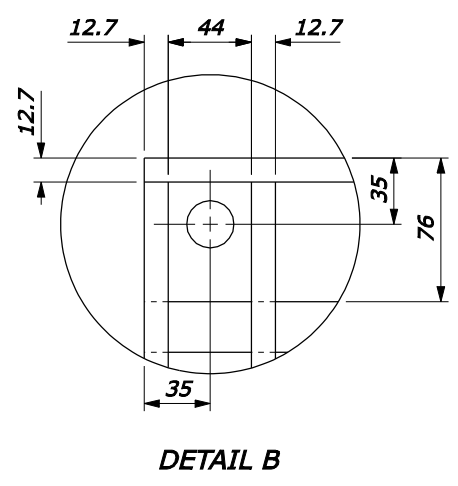
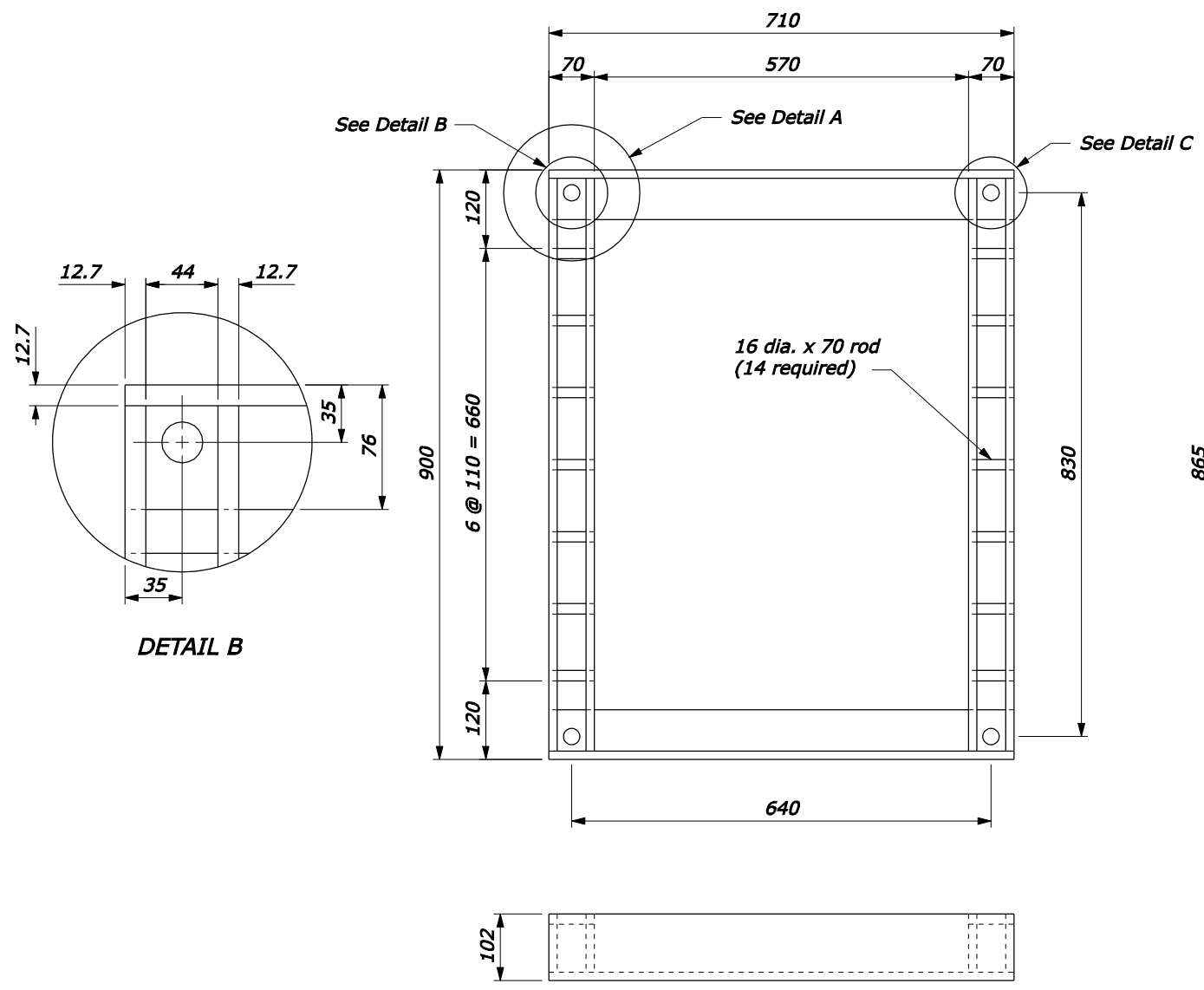

- NOTE:**
- Hot dip galvanize all metal parts for frame and grate after fabrication.
 - Fabricate frame and grate from structural steel.
 - Furnish M20 x 120 x 200 mm anchor bolts with nuts to attach frame to inlet.
 - Cut holes in 89 x 12.7 mm bar as required to place 16 mm diameter rods.
 - Spot weld 16 mm diameter rods for frame and grate to 89 x 12.7 mm bars.
 - Furnish hardware in the metric sizes shown. Equivalent US Customary sizes may be used when metric sizes are not available.
 - Dimensions without units are millimeters.

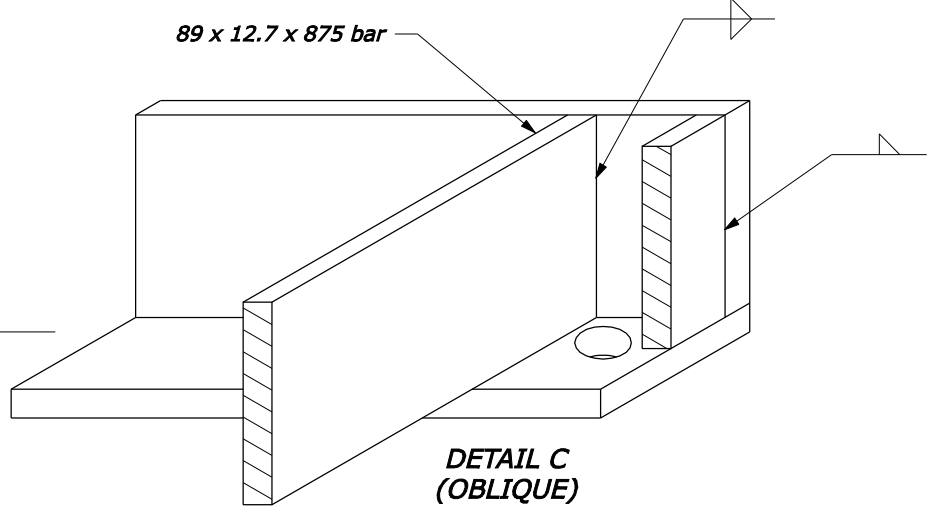
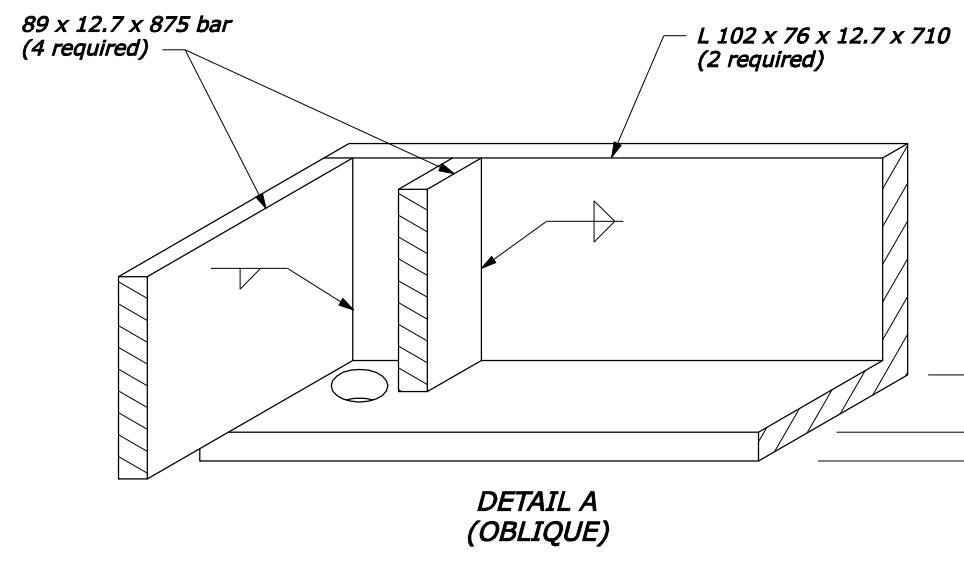
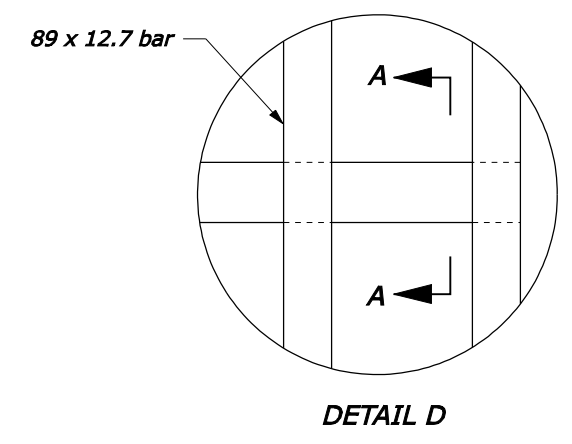
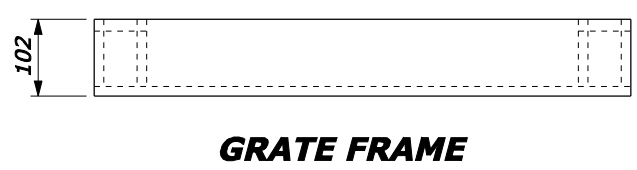
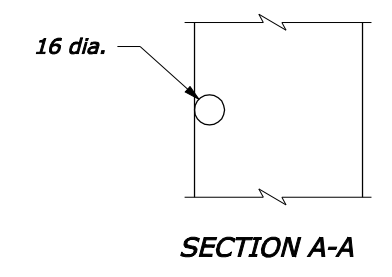

U.S. DEPARTMENT OF TRANSPORTATION FEDERAL HIGHWAY ADMINISTRATION FEDERAL LANDS HIGHWAY	
METRIC STANDARD	
FRAME AND GRATE TYPE 5A	
STANDARD APPROVED FOR USE 3/1996	STANDARD M604-6
REVISED: 6/2005	

NO SCALE

NOTE:

1. Construct inlets parallel to the roadway centerline and grade. For pipes on skew, adapt inlets as directed by the CO.
2. For frames and gratings minor variations in design and dimensions are permitted to allow manufacturers standards.

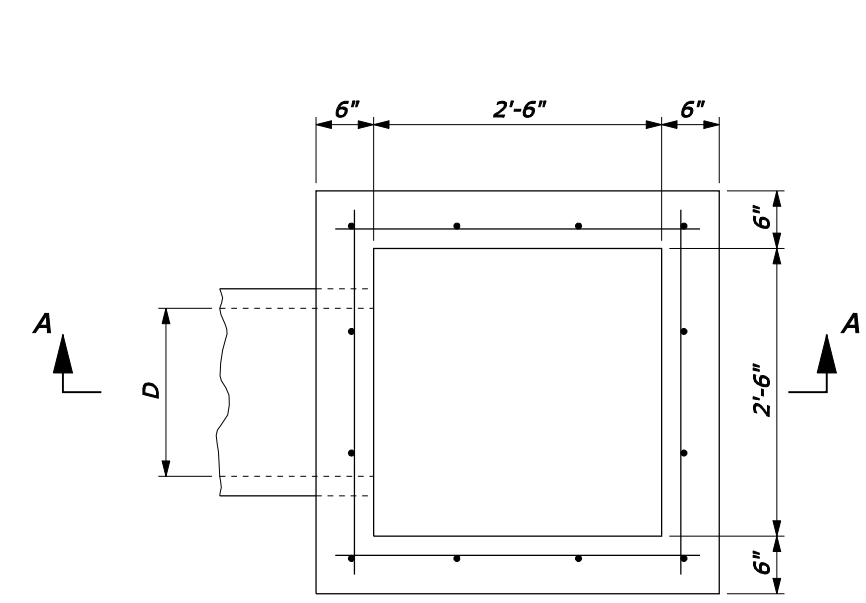

PLAN

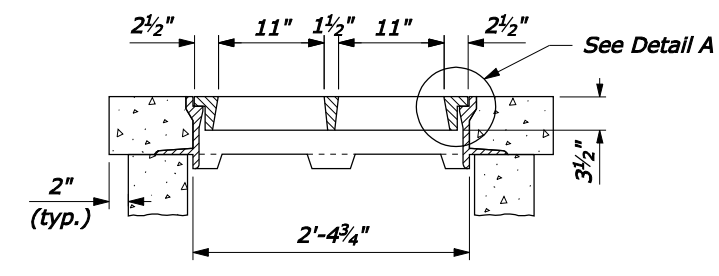
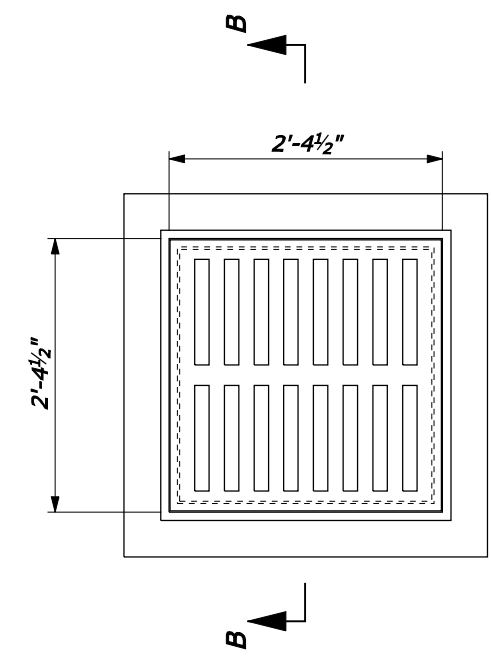

SECTION B-B

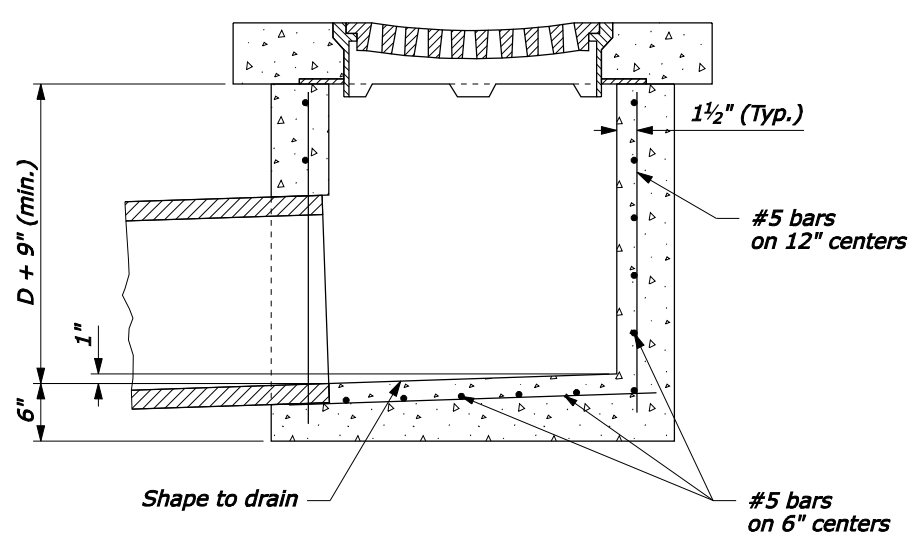

SECTION A-A
TYPE 6B INLET

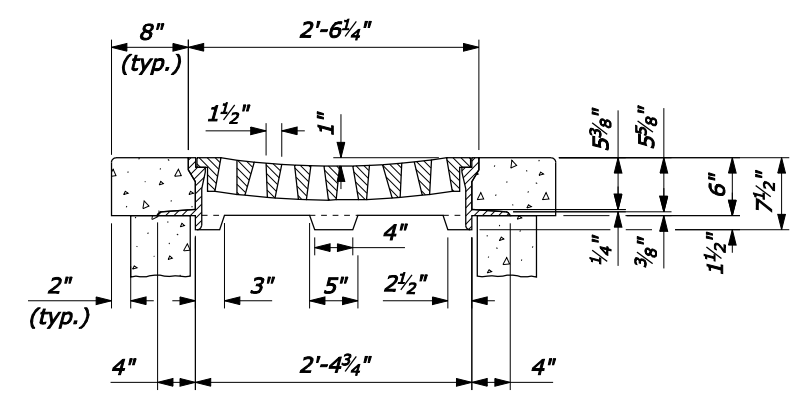

Gray Iron Castings, AASHTO M 105

**METAL FRAMES AND GRATINGS
TYPE 6B**

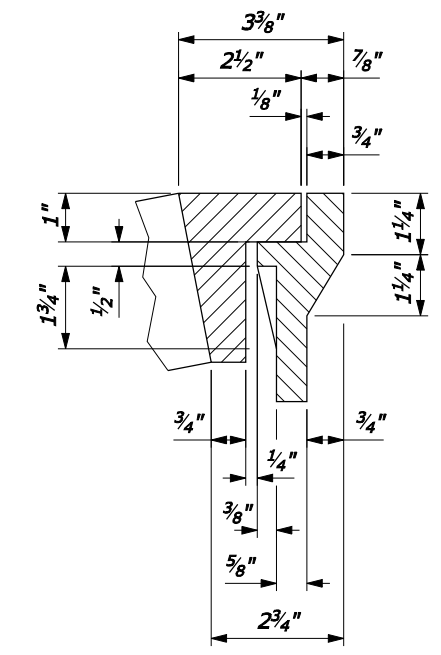

DETAIL A

NO SCALE

U.S. DEPARTMENT OF TRANSPORTATION FEDERAL HIGHWAY ADMINISTRATION FEDERAL LANDS HIGHWAY	
U.S. CUSTOMARY STANDARD	
INLET TYPE 6B	
STANDARD APPROVED FOR USE 6/2005	STANDARD
REVISED:	604-7

- NOTE:**
1. Construct inlets parallel to the roadway centerline and grade. For pipes on skew, adapt inlets as directed by the CO.
 2. For frames and gratings minor variations in design and dimensions are permitted to allow manufacturers standards.
 3. Dimensions without units are millimeters

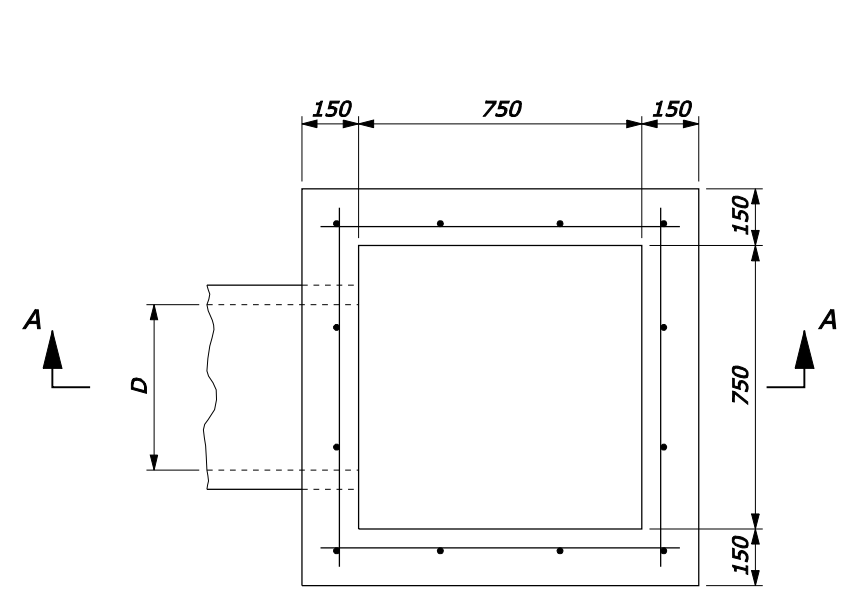

PLAN

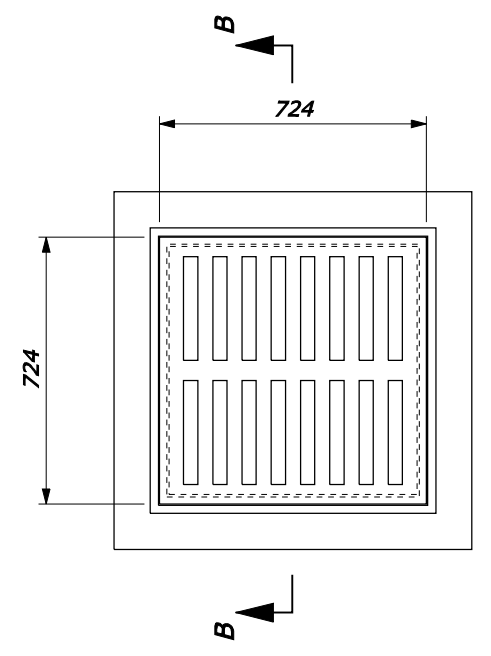

SECTION B-B

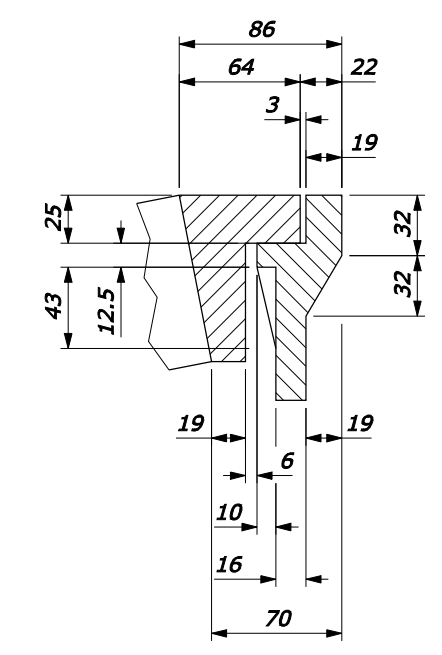
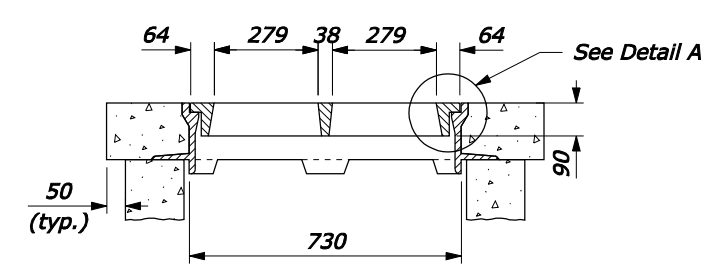

DETAIL A

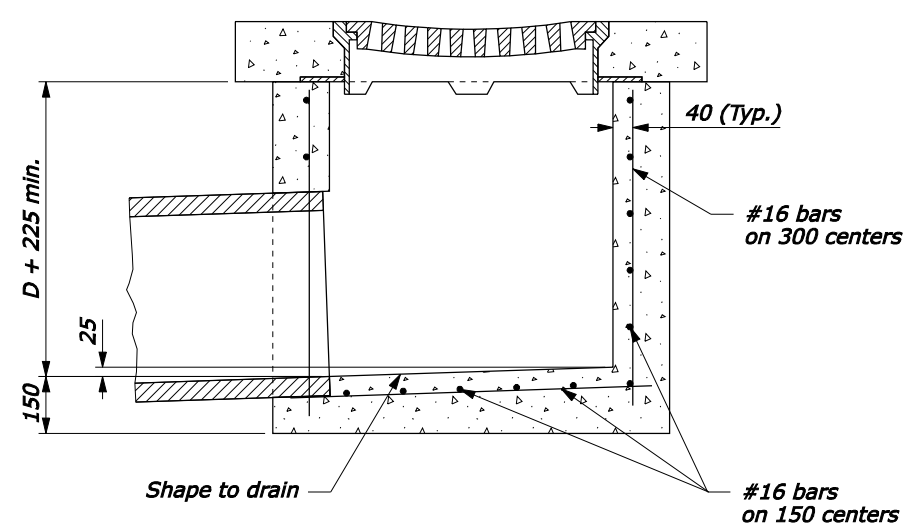

SECTION A-A
TYPE 6B INLET

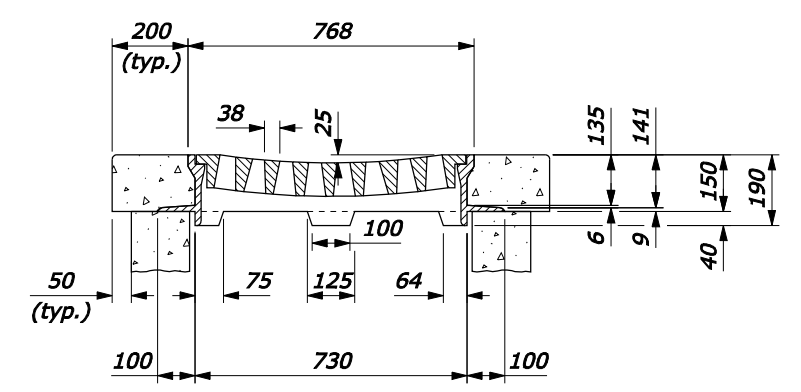

Gray Iron Castings, AASHTO M 105

**METAL FRAMES AND GRATINGS
TYPE 6B**

NO SCALE

U.S. DEPARTMENT OF TRANSPORTATION FEDERAL HIGHWAY ADMINISTRATION FEDERAL LANDS HIGHWAY	
METRIC STANDARD	
INLET TYPE 6B	
STANDARD APPROVED FOR USE 3/1996	STANDARD
REVISED: 5/1997 6/2005	M604-7

01-Nov-2007 03:52 PM
fp://196.145.188.2/scd_plan/ss60407.dgn [Metric]

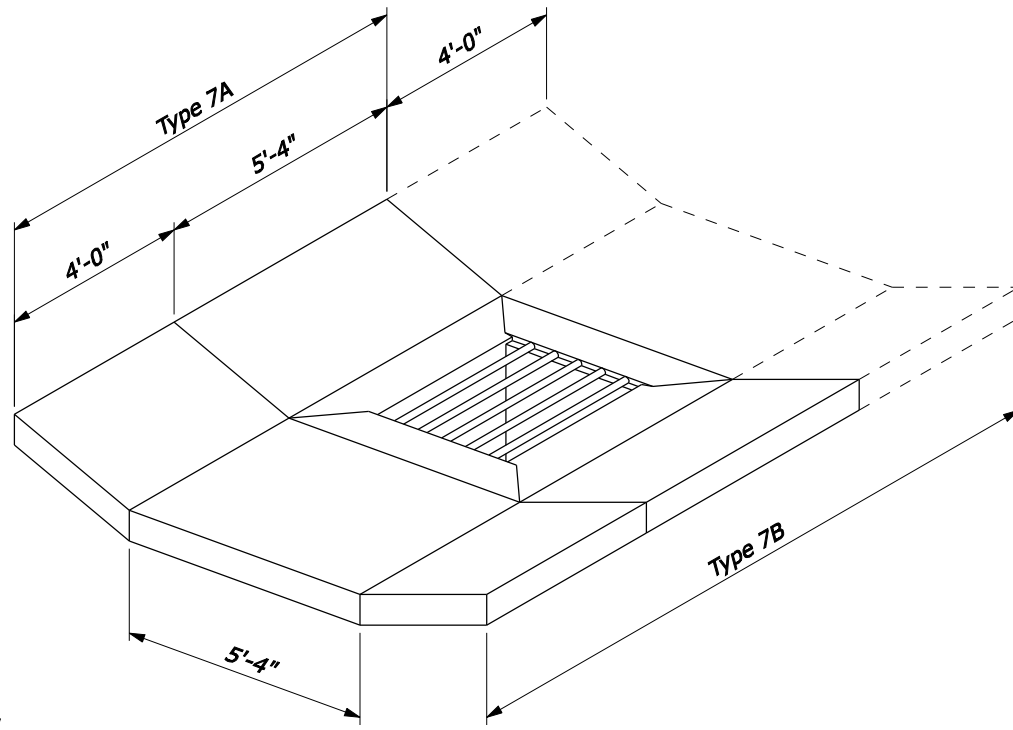
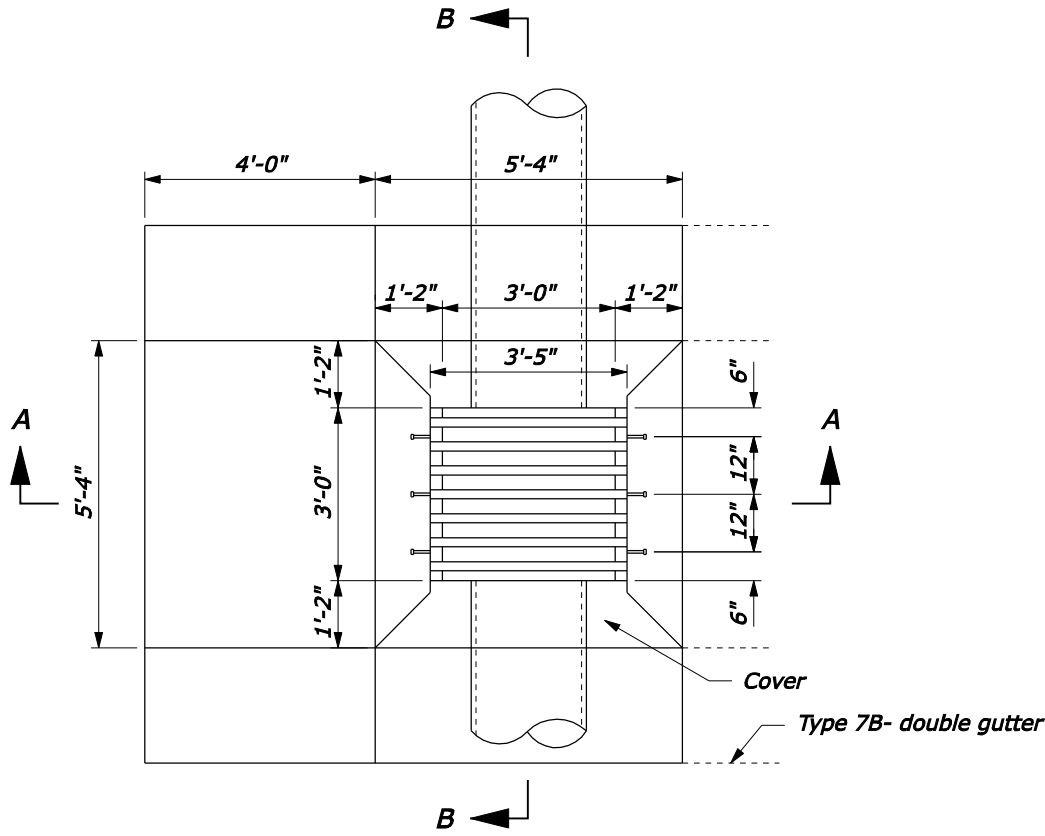

- NOTE:**
- Type 7A has a single gutter when inlet is on a grade.
 - Type 7B has a double gutter when inlet is in a sag between two grades.
 - Ditch to be warped to tie smoothly into inlet gutter.
 - Outside dimensions of grate to be 3'-4" x 2'-11³/₄".
 - Maximum depth (H) is 12'-8".
 - All reinforcing bars are #5 placed a minimum 1¹/₂ inch clear from face of concrete. In floors, place bars on 6 inch centers each way. In walls, place horizontal bars on 6 inch centers and vertical bars on 12 inch centers.
 - Galvanize grate after fabrication in accordance with AASHTO M 111.
 - Alternate methods of anchoring angle iron will be acceptable if approved by the CO.

APPROXIMATE QUANTITIES						
Pipe size	12"	15"	18"	24"	30"	36"
Minimum Depth (H)	2'-0"	2'-3 ¹ / ₄ "	2'-6 ¹ / ₂ "	3'-1"	3'-7 ¹ / ₂ "	4'-2"
Inlet concrete for minimum depth, CUYD	0.947	1.045	1.143	1.339	1.535	1.731
Additional inlet concrete	0.362 cuyd for each additional foot of depth (H)					
Gutter concrete	Type 7A: 0.724 cuyd Type 7B: 1.185 cuyd					
Cover concrete (not included above)	0.413 cuyd					
Cover reinforcing steel	63 lb					

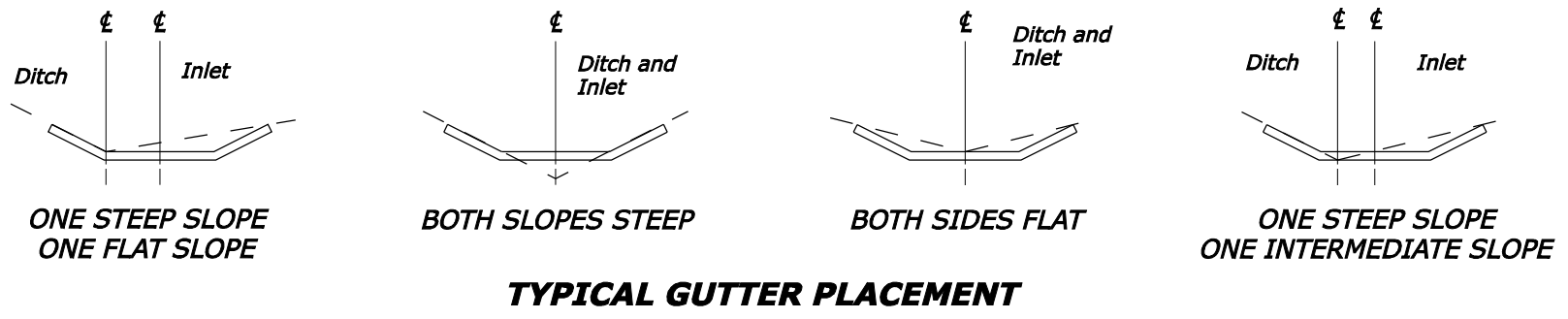
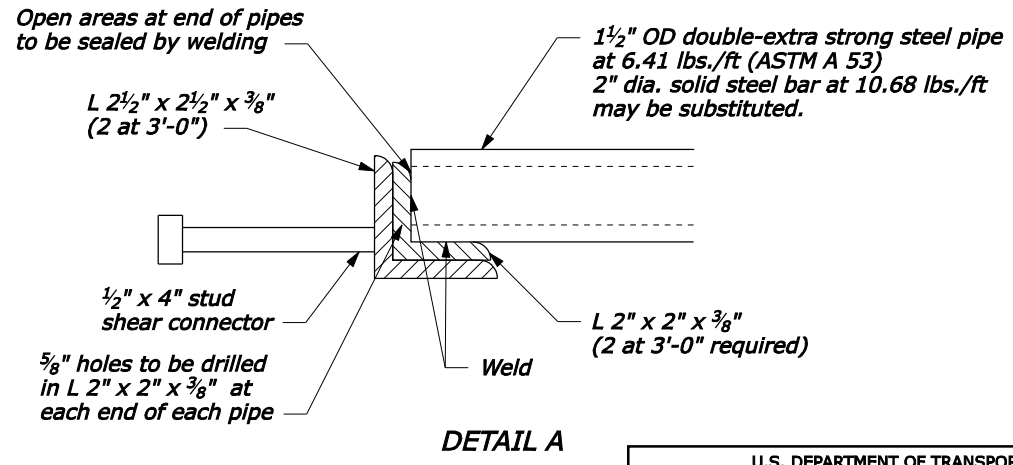
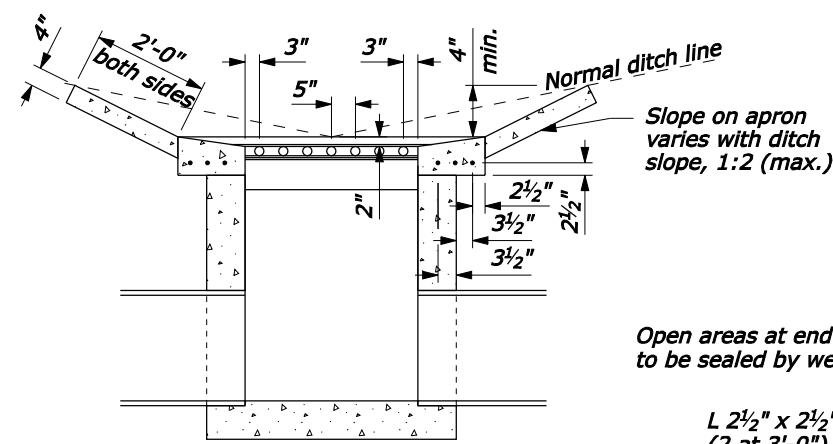
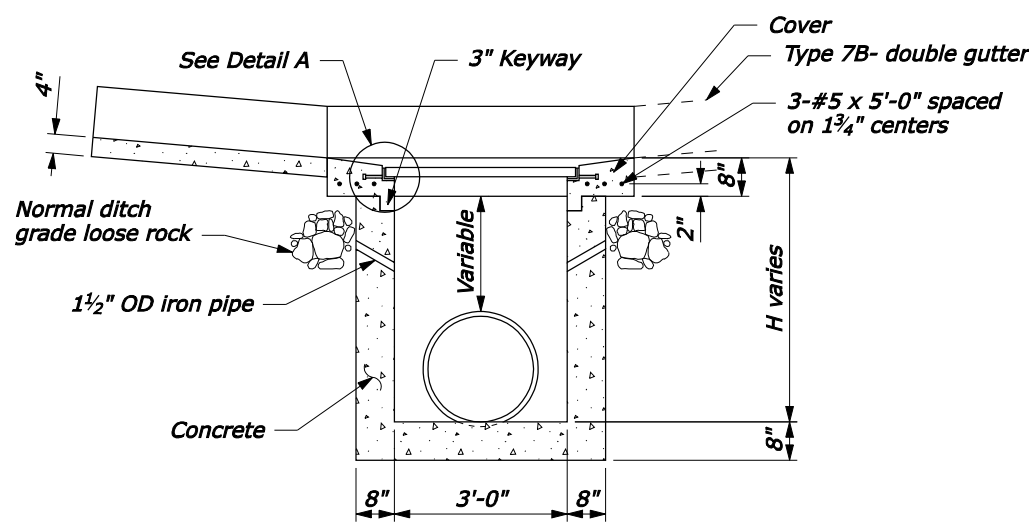

U.S. DEPARTMENT OF TRANSPORTATION
 FEDERAL HIGHWAY ADMINISTRATION
 FEDERAL LANDS HIGHWAY

U.S. CUSTOMARY STANDARD

INLET
TYPE 7A AND 7B
FOR 12" TO 36" CULVERT

STANDARD APPROVED FOR USE 6/2005
 REVISED: 6/2007

STANDARD
 604-8

F:\StdDraw\std60408.dgn [US Customary] 19-Jun-2007 03:00 PM

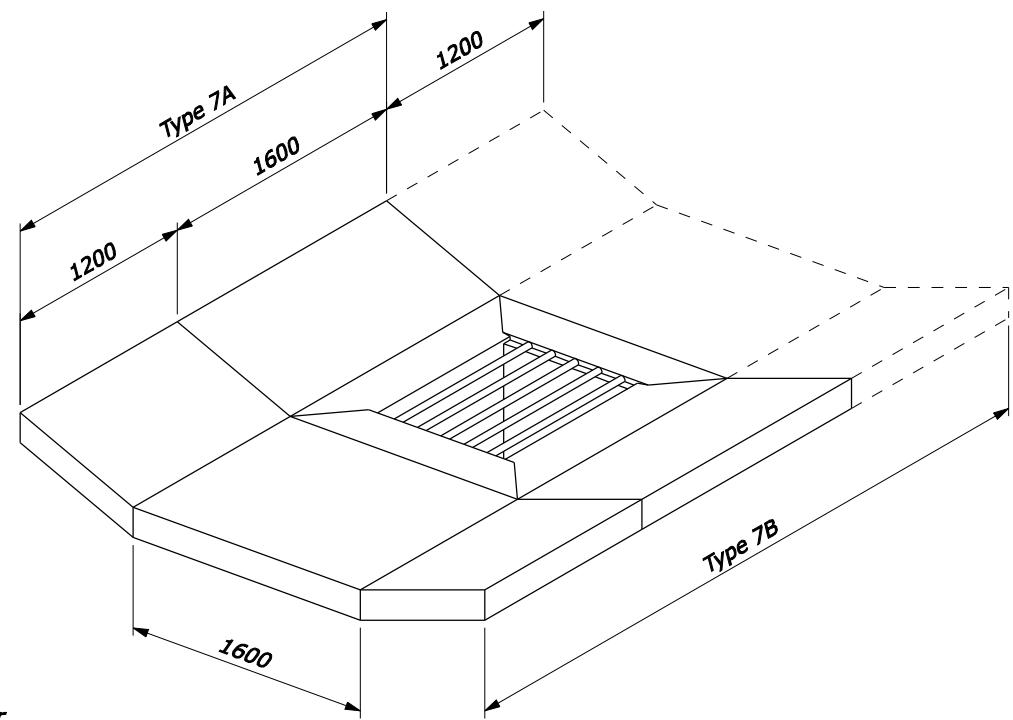
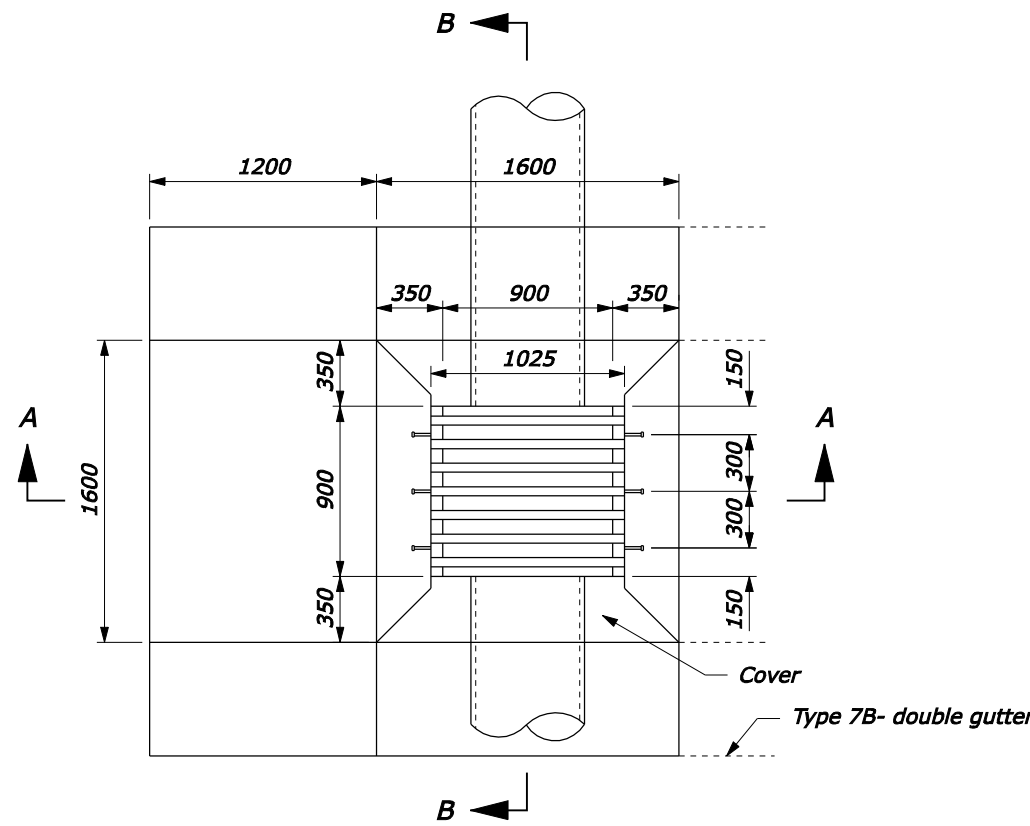

- NOTE:**
- Type 7A has a single gutter when inlet is on a grade.
 - Type 7B has a double gutter when inlet is in a sag between two grades.
 - Ditch to be warped to tie smoothly into inlet gutter.
 - Outside dimensions of grate to be 1000 x 890 mm.
 - Maximum depth (H) is 3800 mm.
 - All reinforcing bars are #16 placed a minimum 40 mm clear from face of concrete. In floors, place bars on 150 mm centers each way. In walls, place horizontal bars on 150 mm centers and vertical bars on 300 mm centers.
 - Galvanize grate after fabrication in accordance with AASHTO M 111.
 - Alternate methods of anchoring angle iron will be acceptable if approved by the CO.
- Dimensions without units are millimeters.

APPROXIMATE QUANTITIES						
Pipe size	300	375	450	600	750	900
Minimum Depth (H)	600	690	775	940	1100	1270
Inlet concrete for minimum depth, m ³	0.690	0.769	0.844	0.989	1.130	1.280
Additional inlet concrete	0.264 m ³ for each additional 300 mm of depth (H)					
Gutter concrete	Type 7A: 0.528 m ³ Type 7B: 0.864 m ³					
Cover concrete (not included above)	0.301 m ³					
Cover reinforcing steel	28.5 kg					

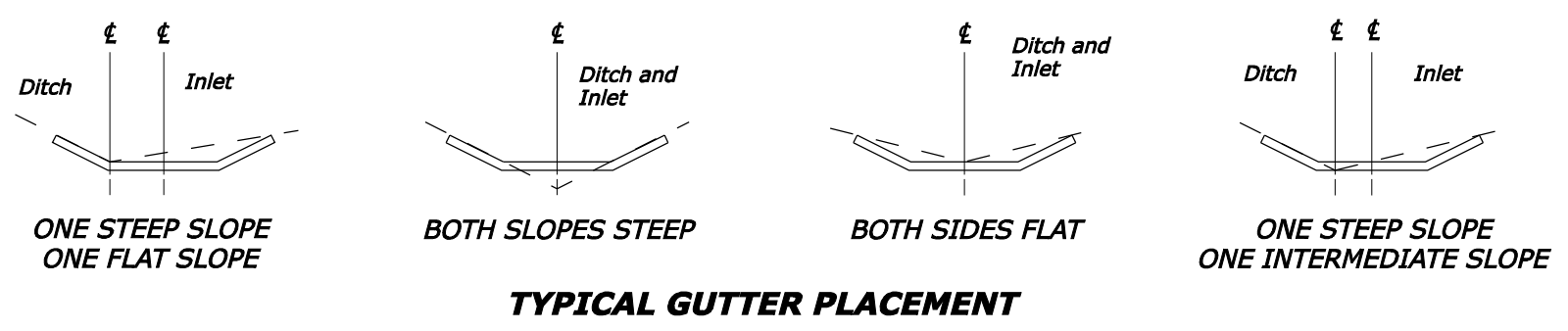
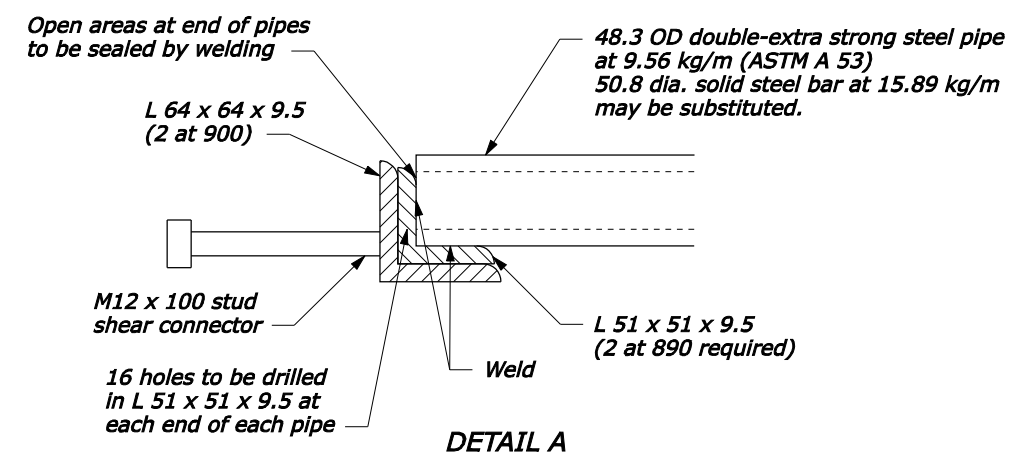
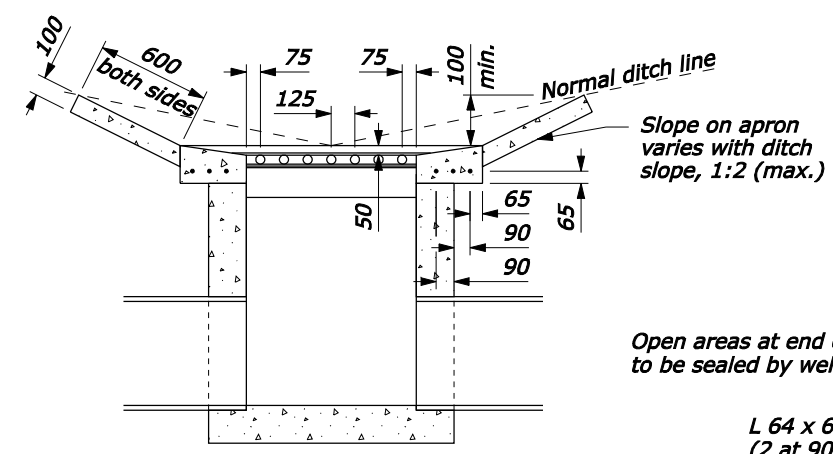
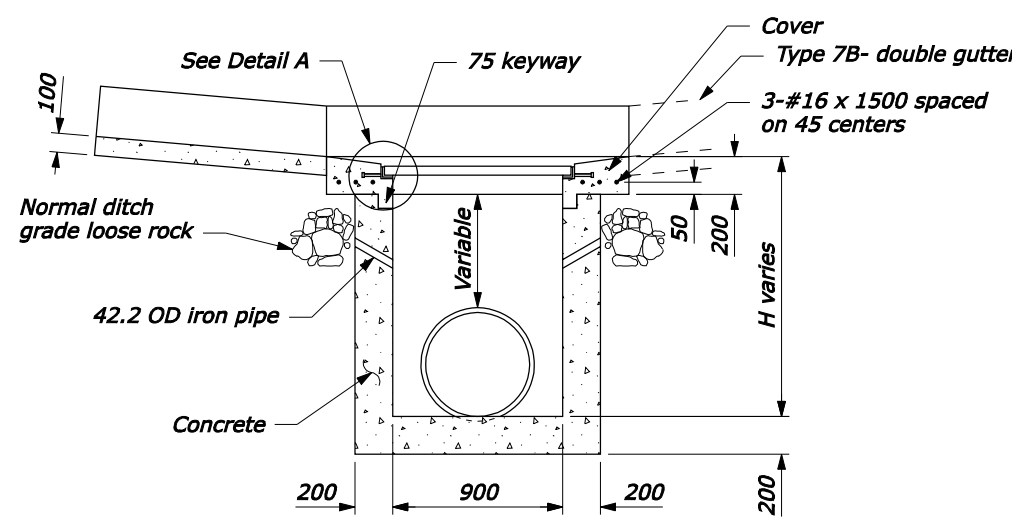

U.S. DEPARTMENT OF TRANSPORTATION
FEDERAL HIGHWAY ADMINISTRATION
FEDERAL LANDS HIGHWAY

METRIC STANDARD

**INLET
TYPE 7A AND 7B
FOR 300 TO 900 CULVERT**

STANDARD APPROVED FOR USE 3/1996
REVISED: 5/1997 6/2005 6/2007

STANDARD
M604-8

NO SCALE

19-Jun-2007 03:02 PM F:\StanDraw\std60406.dgn [Metric]

NOTE:

1. Frame and cover dimensions may vary slightly to allow manufacturer's standards.
2. MASS: (Approximate, cast iron)
 Frame - 86 ± 4 lb
 Cover - 83 ± 4 lb
3. All reinforcing bars are #5 placed a minimum 1½ inch clear from face of concrete. In floors, place bars on 6 inch centers each way. In walls, place horizontal bars on 6 inch centers and vertical bars on 12 inch centers.

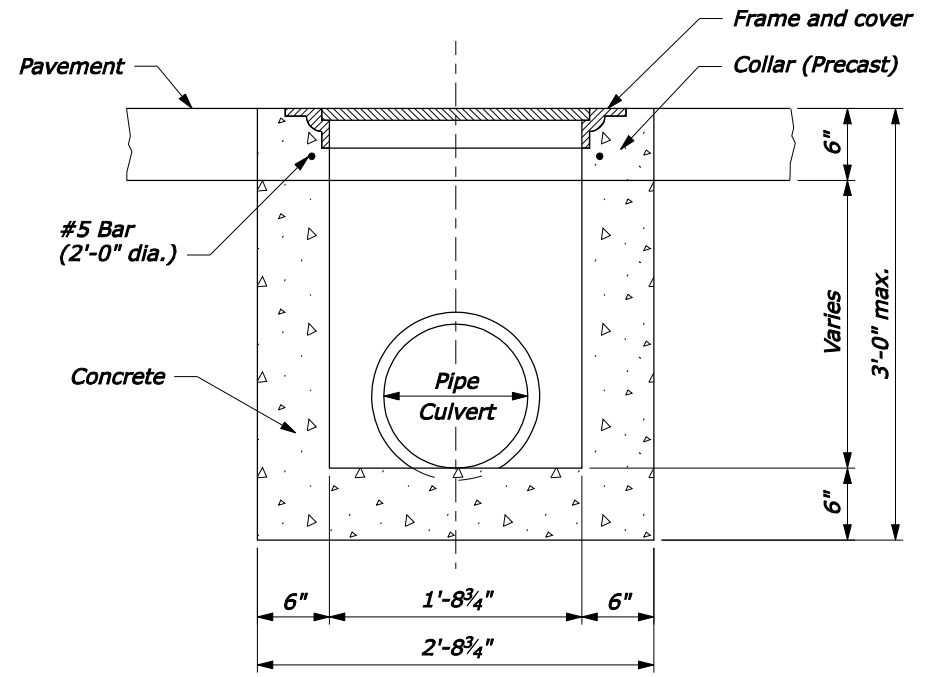

SECTION A-A

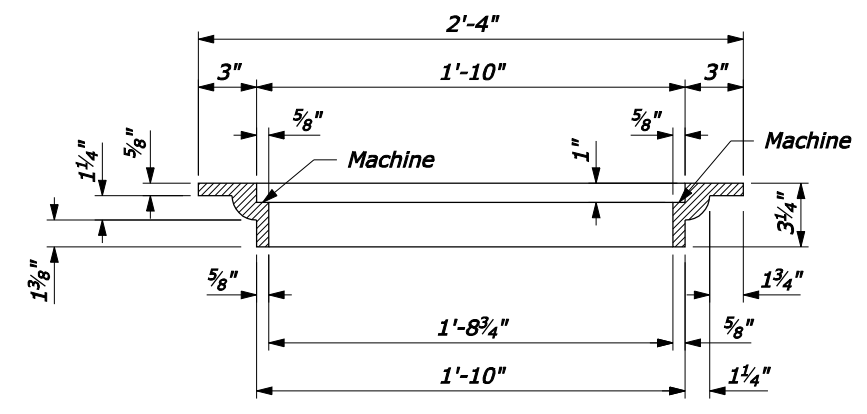

SECTION B-B

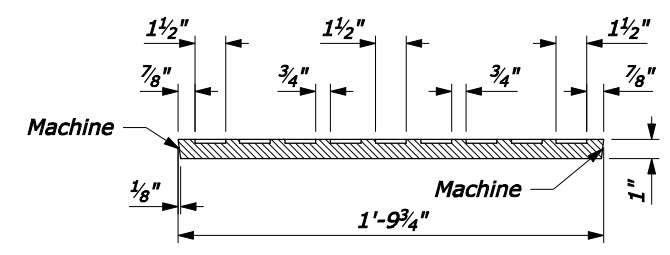

SECTION C-C

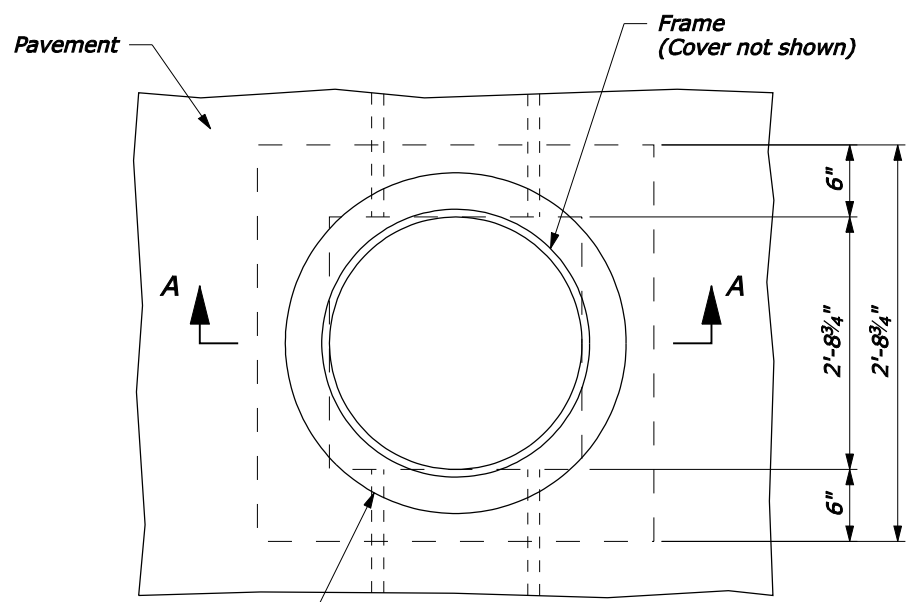

PLAN

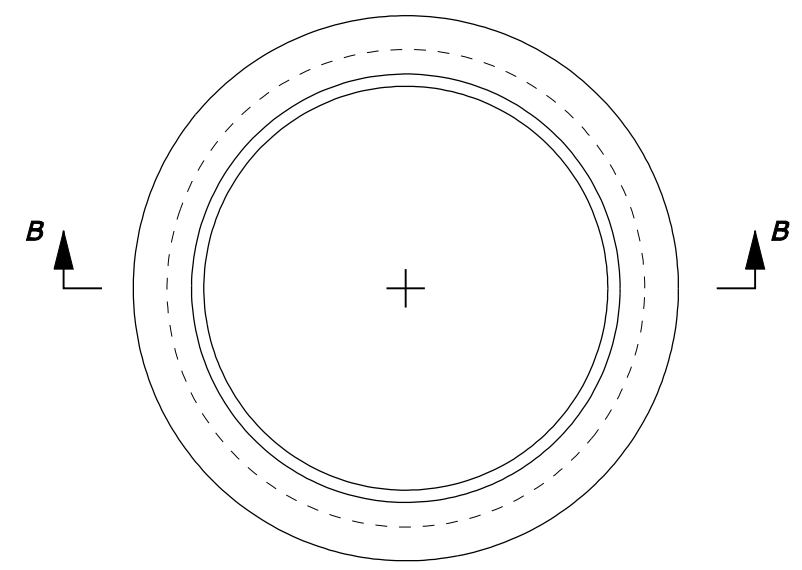

FRAME

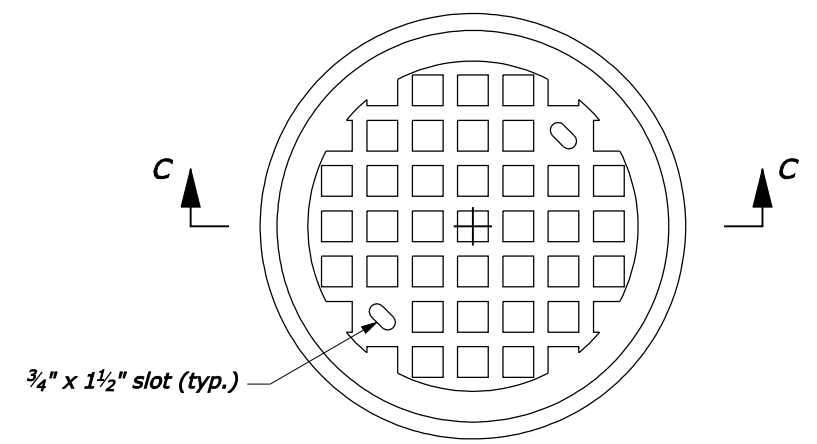

COVER

NO SCALE

U.S. DEPARTMENT OF TRANSPORTATION FEDERAL HIGHWAY ADMINISTRATION FEDERAL LANDS HIGHWAY	
U.S. CUSTOMARY STANDARD	
MANHOLE	
STANDARD APPROVED FOR USE 6/2005	STANDARD
REVISED:	604-9

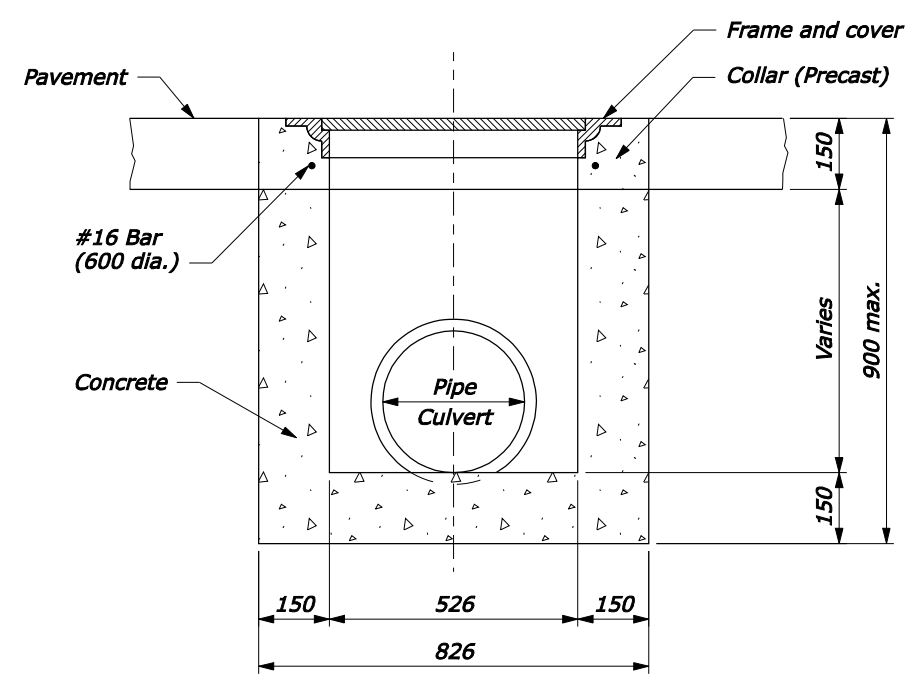

SECTION A-A

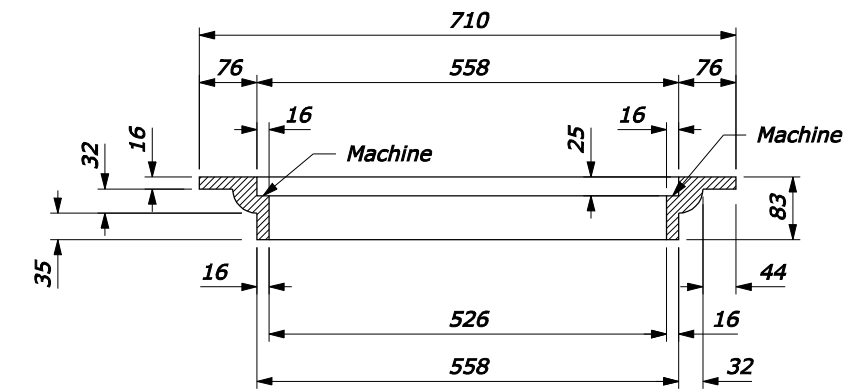

SECTION B-B

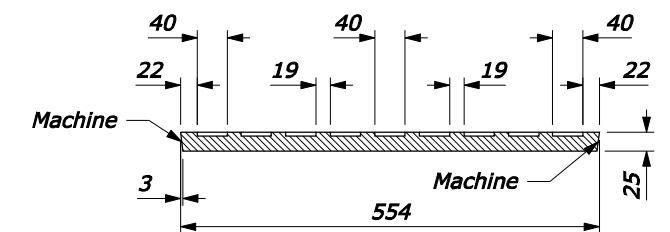

SECTION C-C

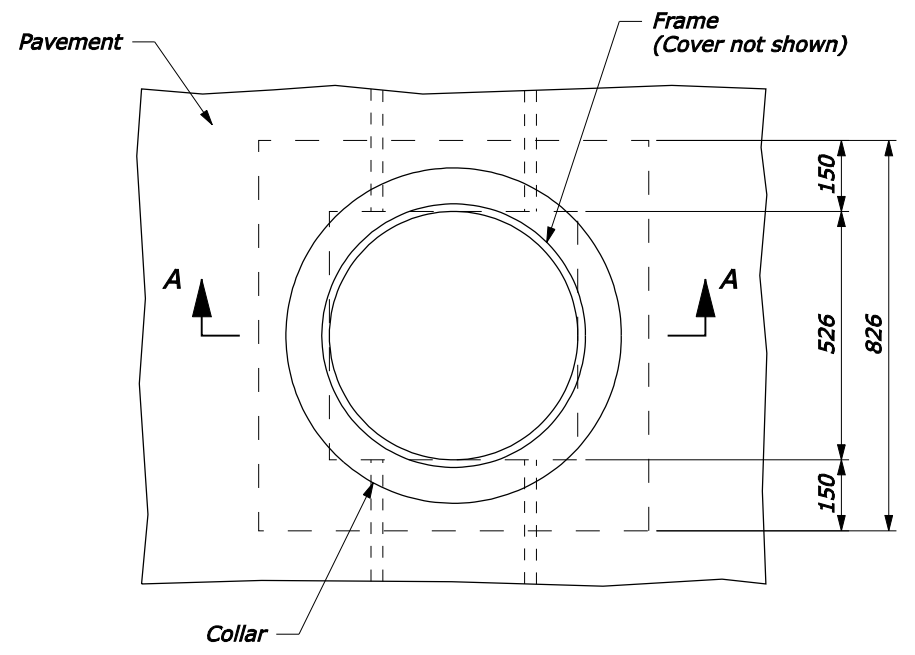

PLAN

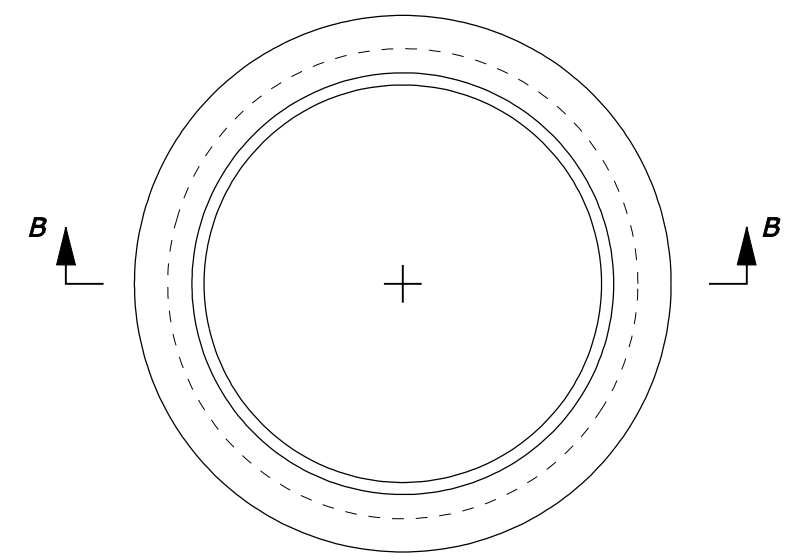

FRAME

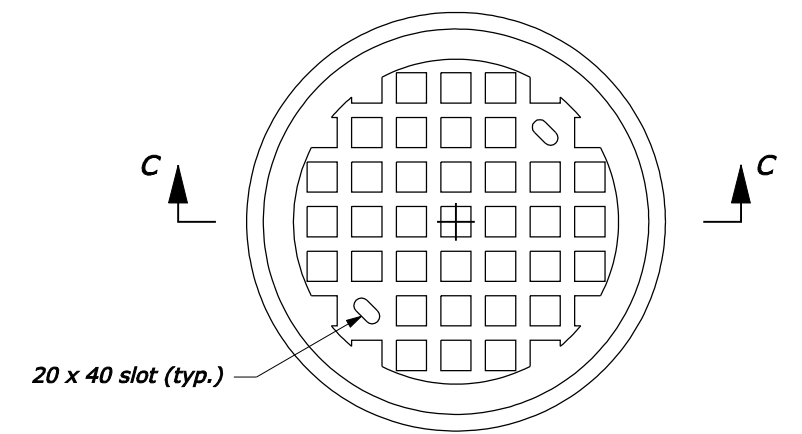

COVER

- NOTE:**
1. Frame and cover dimensions may vary slightly to allow manufacturer's standards.
 2. MASS: (Approximate, cast iron)
 Frame - 39 ± 2 kg
 Cover - 38 ± 2 kg
 3. All reinforcing bars are #16 placed a minimum 40 mm clear from face of concrete. In floors, place bars on 150 mm centers each way. In walls, place horizontal bars on 150 mm centers and vertical bars on 300 mm centers.
 4. Dimensions without units are millimeters.

U.S. DEPARTMENT OF TRANSPORTATION FEDERAL HIGHWAY ADMINISTRATION FEDERAL LANDS HIGHWAY	
METRIC STANDARD	
MANHOLE	
STANDARD APPROVED FOR USE 3/1996	STANDARD
REVISED: 5/1997 6/2005	M604-9

NO SCALE