

HEADWALL FOR DOUBLE PIPE CULVERT

DIMENSIONS, REINFORCING STEEL AND CONCRETE TABLE OF QUANTITIES

D mm	H m	SQUARE HEADWALL					15° SKEW					30° SKEW					45° SKEW				
		A m	B m	L m	CONC. m3	STEEL kg	A m	B m	L m	CONC. m3	STEEL kg	A m	B m	L m	CONC. m3	STEEL kg	A m	B m	L m	CONC. m3	STEEL kg
1200	1.500	1.2	1.8	4.2	1.55	80	1.2	1.9	4.3	1.58	81	1.4	2.1	4.9	1.81	92	1.7	2.5	5.9	2.18	111
1350	1.575	1.4	2.0	4.8	1.84	93	1.4	2.1	4.9	1.87	93	1.6	2.3	5.5	2.10	107	2.0	2.9	6.9	2.65	134
1500	1.650	1.6	2.3	5.5	2.19	110	1.6	2.3	5.5	2.17	109	1.8	2.6	6.2	2.46	124	2.2	3.2	7.6	3.01	149
1650	1.725	1.8	2.5	6.1	2.52	129	1.8	2.6	6.2	2.54	133	2.0	2.9	6.9	2.83	146	2.5	3.5	8.5	3.49	182
1800	1.800	2.0	2.7	6.7	2.85	147	2.0	2.8	6.8	2.88	147	2.3	3.1	7.7	3.28	168	2.8	3.8	9.4	4.00	204
1950	1.875	2.1	2.9	7.1	3.10	155	2.2	3.0	7.4	3.23	162	2.5	3.4	8.4	3.69	184	3.0	4.1	10.1	4.41	222
2100	1.950	2.3	3.2	7.8	3.52	183	2.4	3.3	8.1	3.66	191	2.7	3.6	9.0	4.07	213	3.3	4.5	11.1	5.02	263
2250	2.025	2.5	3.4	8.4	3.91	199	2.6	3.5	8.7	4.05	211	2.9	3.9	9.7	4.52	234	3.6	4.8	12.0	5.60	291
2400	2.100	2.7	3.6	9.0	4.31	219	2.8	3.7	9.3	4.45	227	3.1	4.2	10.4	4.98	252	3.8	5.1	12.7	6.08	311
2550	2.175	2.9	3.8	9.6	4.73	247	3.0	3.9	9.9	4.87	255	3.3	4.3	10.9	5.34	279	4.1	5.3	13.5	6.64	351
2700	2.250	3.1	3.9	10.1	5.10	265	3.2	4.0	10.4	5.24	271	3.6	4.5	11.7	5.91	309	4.3	5.5	14.1	7.09	369
2850	2.325	3.3	4.0	10.6	5.48	281	3.4	4.2	11.0	5.69	293	3.8	4.7	12.3	6.37	328	4.6	5.7	14.9	7.69	393
3000	2.400	3.5	4.2	11.2	5.94	304	3.6	4.3	11.5	6.08	309	4.0	4.8	12.8	6.77	344	4.9	5.9	15.7	8.31	424
3150	2.475	3.6	4.3	11.5	6.20	325	3.8	4.5	12.1	6.56	341	4.2	5.0	13.4	7.25	378	5.1	6.2	16.4	8.87	463
3300	2.550	3.8	4.5	12.1	6.69	345	4.0	4.7	12.7	7.06	366	4.4	5.2	14.0	7.75	402	5.4	6.4	17.2	9.53	494
3450	2.625	4.0	4.7	12.7	7.20	370	4.2	4.8	13.2	7.49	384	4.6	5.4	14.6	8.26	419	5.7	6.6	18.0	10.21	524
3600	2.700	4.2	4.8	13.2	7.64	403	4.3	5.0	13.6	7.85	410	4.8	5.5	15.1	8.70	454	5.9	6.8	18.6	10.75	565
3750	2.775	4.4	5.0	13.8	8.18	424	4.5	5.1	14.1	8.31	429	5.1	5.7	15.9	9.41	485	6.2	7.0	19.4	11.46	593
3900	2.850	4.6	5.1	14.3	8.64	444	4.7	5.3	14.7	8.86	456	5.3	5.9	16.5	9.97	512	6.5	7.2	20.2	12.20	630
4050	2.925	4.8	5.3	14.9	9.21	482	4.9	5.4	15.2	9.34	493	5.5	6.1	17.1	10.54	554	6.7	7.4	20.8	12.79	676
4200	3.000	5.0	5.4	15.4	9.70	503	5.1	5.6	15.8	9.92	516	5.7	6.2	17.6	11.04	574	7.0	7.6	21.6	13.56	706
4350	3.075	5.1	5.5	15.7	10.02	518	5.3	5.7	16.3	10.42	536	5.9	6.4	18.2	11.64	603	7.3	7.8	22.4	14.36	740
4500	3.150	5.3	5.7	16.3	10.63	542	5.5	5.9	16.9	11.03	560	6.1	6.6	18.8	12.26	627	7.5	8.1	23.1	15.08	773

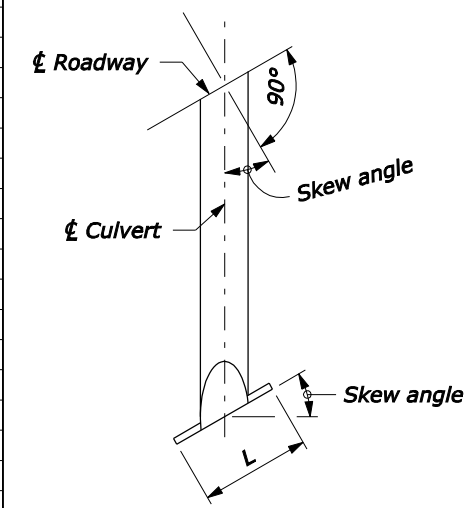
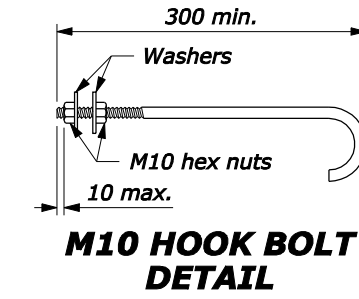

TYPICAL HALF PLAN

- NOTE:**
- Concrete conforms to Section 601. Pour concrete monolithically. Chamfer all exposed edges 20 mm and finish all exposed surfaces with a Class 1 ordinary finish.
 - Clearance for reinforcing steel is 50 mm unless otherwise noted.
 - Headwall dimension "H" may be reduced in solid rock provided the wall is keyed into the rock at least 300 mm. Excavate and backfill according to Section 209.
 - Set hook bolts on nominal 450 mm centers around pipe perimeter at center of headwall. Hook bolts conform to ASTM A307. Galvanize according to ASTM A153.
 - For installations with more than two pipe culverts, increase the dimension "L" and all quantities shown for double pipe installation by adding a length equal to dimension "B" and the incremental change in quantities for each additional pipe culvert.
 - For skews other than those shown, multiply quantities and dimensions "A", "B" & "L" for square headwalls by secant of the skew angle.
 - Final quantities will be determined by using the tables on this standard.
 - Do not order materials until the length, skew angle, and slope bevel in the field have been approved.
 - Dimensions without units are millimeters.

HEADWALL FOR SINGLE PIPE CULVERT

DIMENSIONS, REINFORCING STEEL AND CONCRETE TABLE OF QUANTITIES

D mm	H m	SQUARE HEADWALL			15° SKEW			30° SKEW			45° SKEW		
		L m	CONC. m3	STEEL kg	L m	CONC. m3	STEEL kg	L m	CONC. m3	STEEL kg	L m	CONC. m3	STEEL kg
1200	1.500	2.4	0.91	45	2.5	0.95	49	2.8	1.06	54	3.4	1.29	65
1350	1.575	2.8	1.11	56	2.9	1.15	57	3.2	1.26	66	3.9	1.54	78
1500	1.650	3.2	1.32	67	3.3	1.36	68	3.6	1.48	73	4.5	1.85	94
1650	1.725	3.5	1.49	78	3.6	1.53	79	4.1	1.75	91	5.0	2.13	112
1800	1.800	3.9	1.72	87	4.0	1.76	92	4.5	1.99	103	5.5	2.43	127
1950	1.875	4.3	1.97	99	4.4	2.01	100	4.9	2.24	111	6.0	2.74	140
2100	1.950	4.7	2.23	119	4.8	2.27	120	5.4	2.56	134	6.6	3.13	164
2250	2.025	5.0	2.44	126	5.2	2.54	133	5.8	2.83	146	7.1	3.47	181
2400	2.100	5.4	2.72	138	5.6	2.83	145	6.2	3.12	162	7.6	3.83	196
2550	2.175	5.8	3.02	159	6.0	3.12	166	6.7	3.49	186	8.2	4.27	228
2700	2.250	6.2	3.33	175	6.4	3.43	179	7.1	3.80	199	8.7	4.66	247
2850	2.325	6.5	3.58	187	6.8	3.75	193	7.5	4.13	214	9.2	5.06	264
3000	2.400	6.9	3.91	197	7.1	4.01	205	8.0	4.54	234	9.8	5.56	284
3150	2.475	7.3	4.25	225	7.5	4.36	229	8.4	4.89	255	10.3	5.99	318
3300	2.550	7.7	4.61	241	7.9	4.72	244	8.8	5.25	275	10.8	6.45	337
3450	2.625	8.0	4.90	254	8.3	5.08	260	9.3	5.70	294	11.3	6.92	356
3600	2.700	8.4	5.28	276	8.7	5.47	292	9.7	6.09	323	11.9	7.48	396
3750	2.775	8.8	5.67	297	9.1	5.86	304	10.1	6.50	339	12.4	7.98	417
3900	2.850	9.2	6.07	315	9.5	6.27	326	10.6	6.99	360	12.9	8.50	437
4050	2.925	9.5	6.40	342	9.9	6.69	351	11.0	7.42	396	13.5	9.11	488
4200	3.000	9.9	6.83	355	10.2	7.03	372	11.4	7.86	410	14.0	9.66	511
4350	3.075	10.3	7.27	379	10.6	7.47	386	11.9	8.40	436	14.5	10.22	533
4500	3.150	10.7	7.73	399	11.0	7.93	410	12.3	8.87	456	15.1	10.90	563

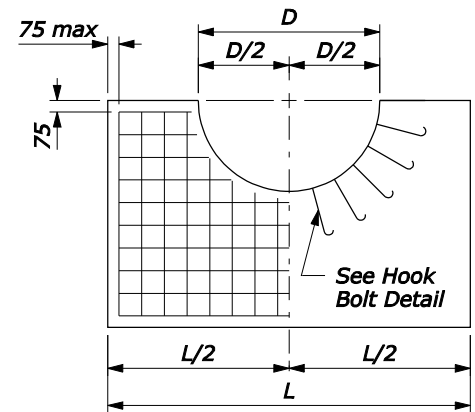

SINGLE PIPE CULVERT

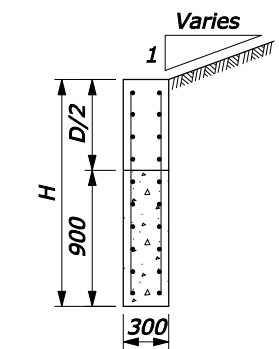

SECTION A-A

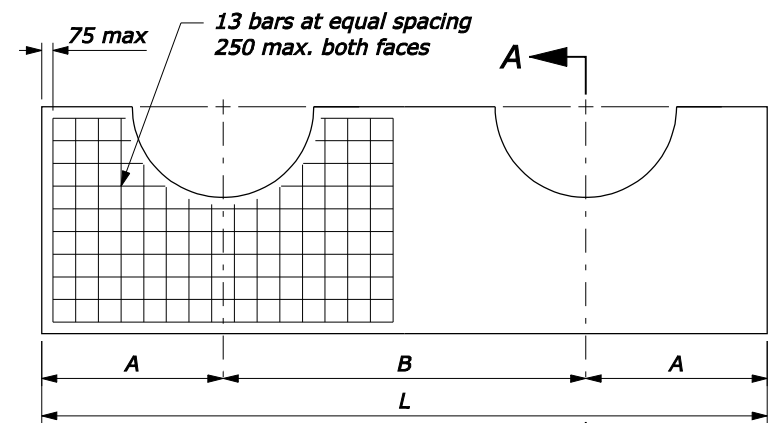

DOUBLE PIPE CULVERT HEADWALLS

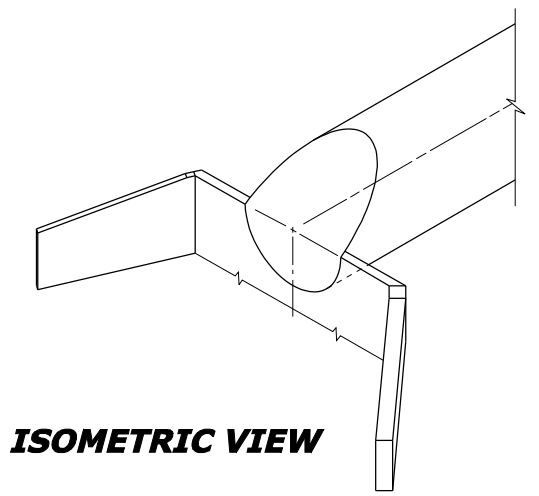

ISOMETRIC VIEW

U.S. DEPARTMENT OF TRANSPORTATION
FEDERAL HIGHWAY ADMINISTRATION
FEDERAL LANDS HIGHWAY
METRIC STANDARD

CONCRETE HEADWALLS

STANDARD APPROVED FOR USE 3/1996
REVISED: 5/1997 6/2005

STANDARD
M601-1

NO SCALE