

Workshop #2

***connected vehicle* Core System Architecture/Requirements**

September 20-22, 2011

San Jose, CA

Day 3

Systems Engineering Team

Thursday

»» Welcome to Day 3

Agenda – Thursday 9/22

9:00	Welcome & Recap
9:30	Architecture, Communications Views Discussion
10:15	Break
10:30	Architecture, Information Viewpoint Discussion
11:00	Core System Deployment Options
11:45	Lunch
1:00	Core System Risks (Barriers to Deployment)
1:45	Next Steps
2:30	Adjourn

Core System provides services that...

- Enable data transfers between System Users
 - Mobile
 - Field
 - Center
- Are in a secure, trusted environment
 - Enabling trust between parties that have no direct relationship
 - Enabling secure data exchange between parties that have no direct relationship
 - Enabling the exchange of data between parties that have data and parties that want data

Core System in the context of the *connected vehicle* environment

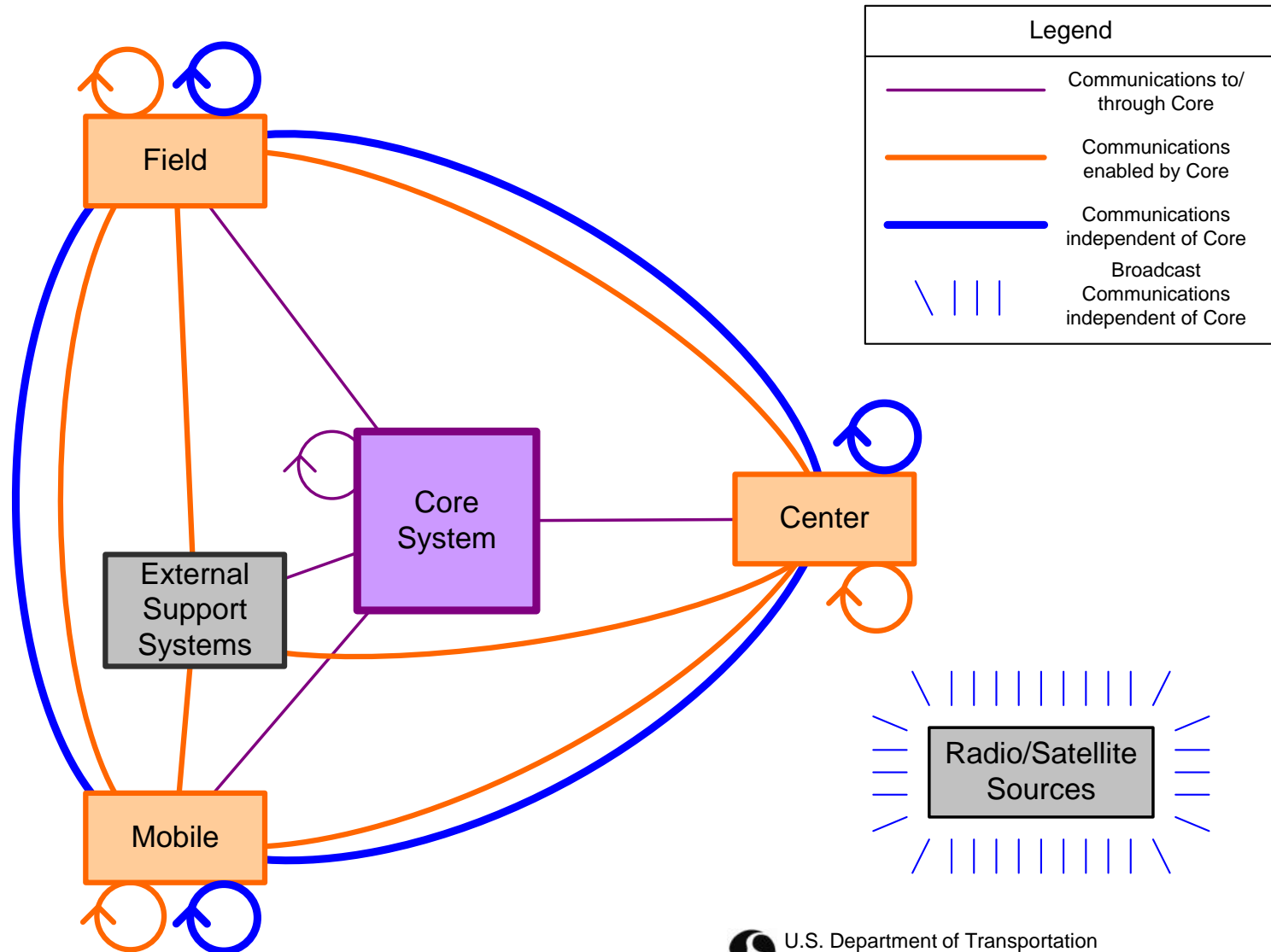

Core System's 8 Subsystems

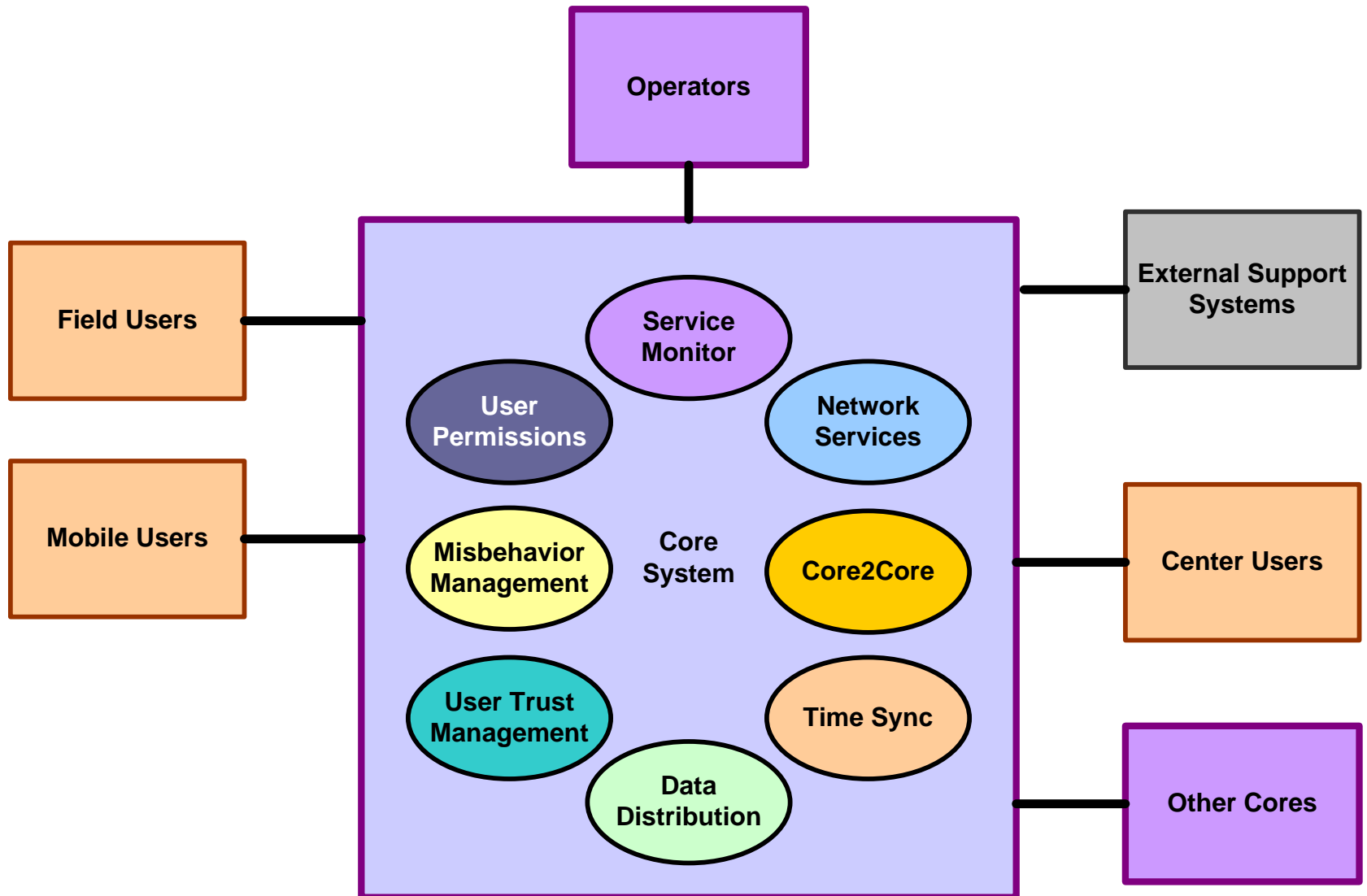





Core System Architecture: Communications Views

- » Views that will describe the layered communications protocols

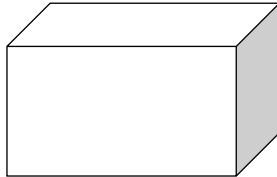
Communications

- Layered communications protocols between nodes
- Links are traceable to interface requirements

	Protocol entities
	Node
	Link between nodes
	Logical link between protocol entities
	Software engineering object

Communications Views Defined

- Mobile DSRC Device and Core
- Mobile Wide-Area Wireless User and Core
- Fixed Point Center/Field User and Core, Core2Core
- Core Routing

Communications View 4.4.1 – Mobile DSRC Device and Core

- Description:
 - 1st of 2 views showing how Mobile Users can communicate with the Core
 - Shows the intermediary steps to go from Mobile to Core
 - Based on 5.9 GHz DSRC using IEEE 1609.x, 802.11p standards

Communications View 4.4.1 – Mobile DSRC Device and Core

- Considerations/Concerns Addressed:
 - Performance
 - Interfaces
 - Functionality
 - Security
 - Organization/
Resources
 - Appropriateness
 - Feasibility
 - Risks
 - Evolvability
 - Deployability

Communications View 4.4.1 – Mobile DSRC Device and Core

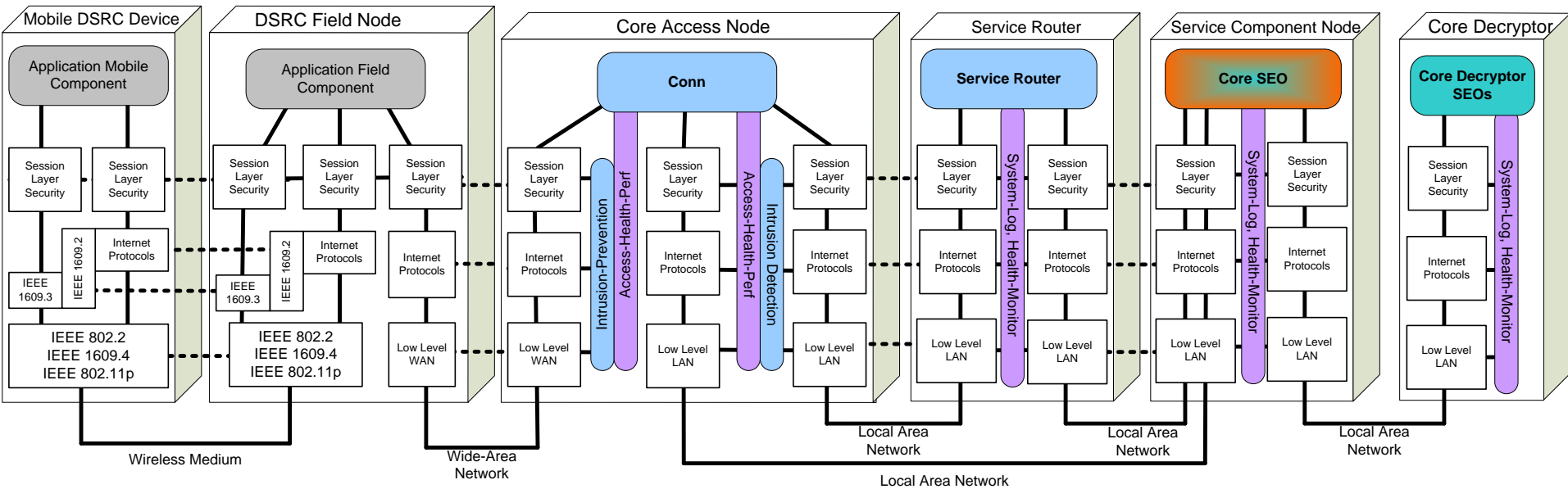

Communications View 4.4.1 – Mobile DSRC Device and Core

Left Side

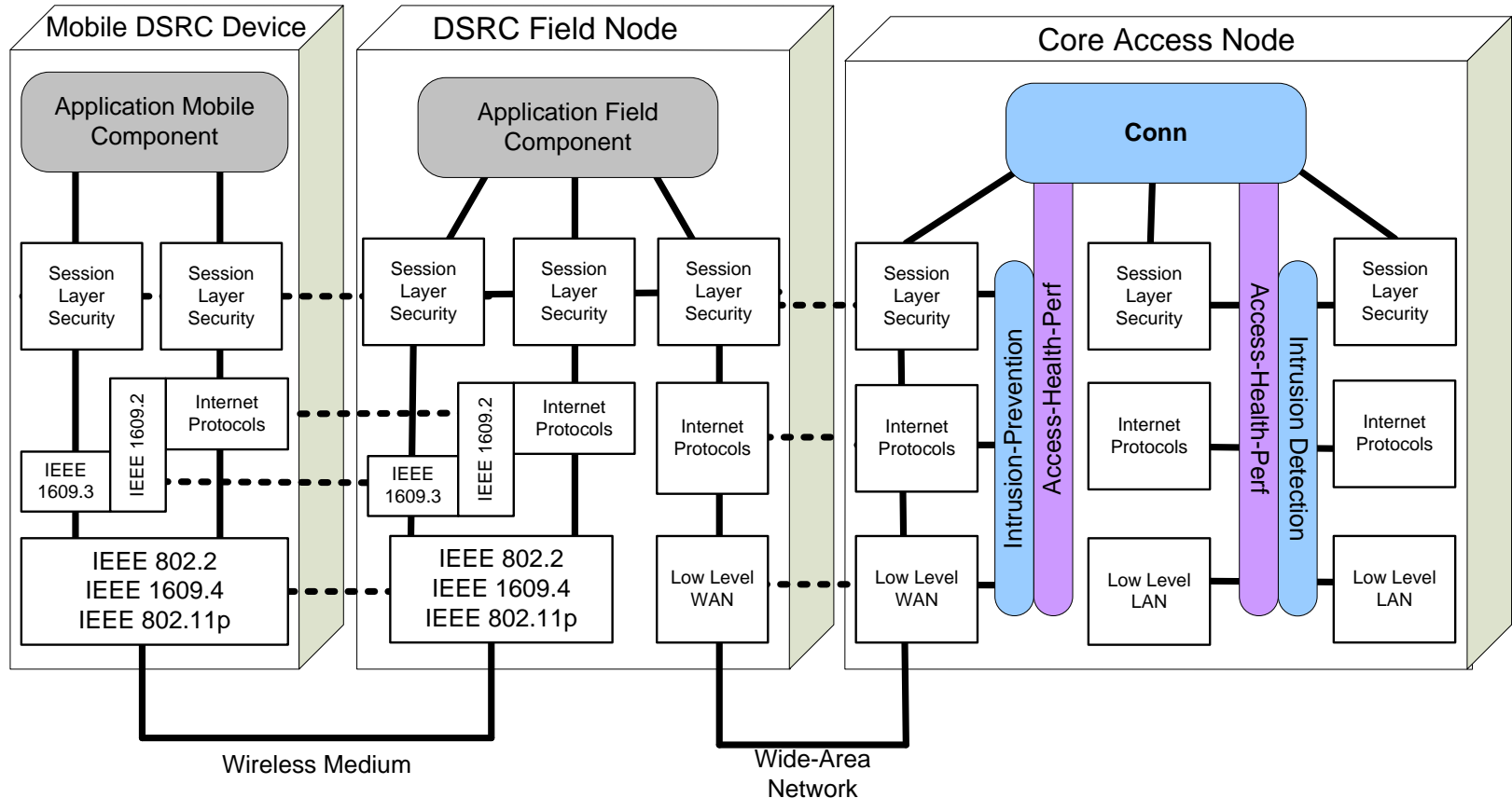

Communications View 4.4.1 – Mobile DSRC Device and Core

Right Side

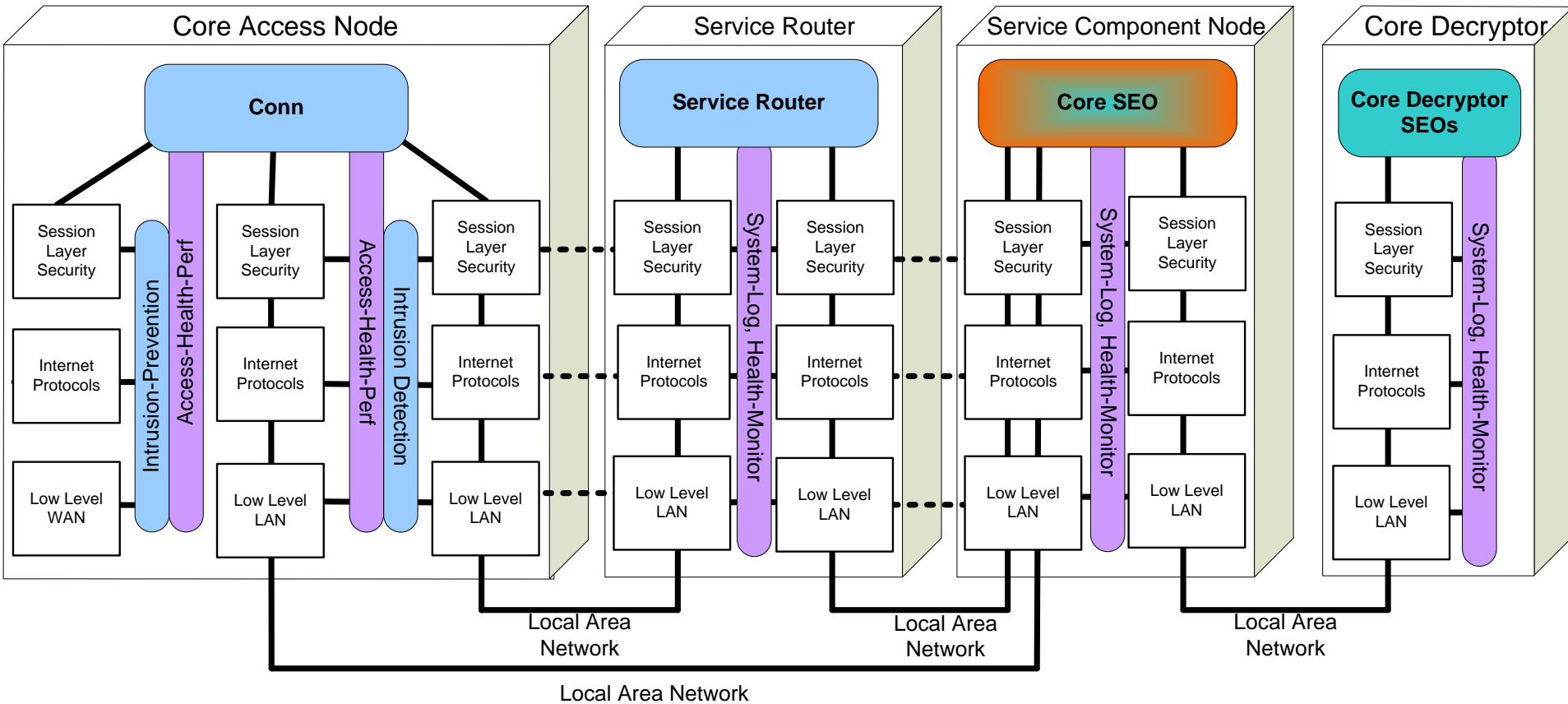

Communications View 4.4.1 – Mobile DSRC Device and Core

Related Views:

- Enterprise Views
 - Business Model
- Functional Views
 - Core Decryption
- Connectivity Views
 - High Level
 - Core System
 - Functional Allocation
- Communications Views
 - Mobile Wide-Area Wireless User and Core
 - Fixed Point Center/Field User and Core, Core2Core
 - Core Routing

Communications View 4.4.2 – Mobile Wide-Area Wireless User and Core

- Description:
 - 2nd of 2 views showing how Mobile Users can communicate with the Core
 - Shows the intermediary steps to go from Mobile to Core
 - Based on WiFi, cellular, other wireless communications

Communications View 4.4.2 – Mobile Wide-Area Wireless User and Core

- Considerations/Concerns Addressed:
 - Performance
 - Interfaces
 - Functionality
 - Security
 - Organization/
Resources
 - Appropriateness
 - Feasibility
 - Risks
 - Evolvability
 - Deployability

Communications View 4.4.2 – Mobile Wide-Area Wireless User and Core

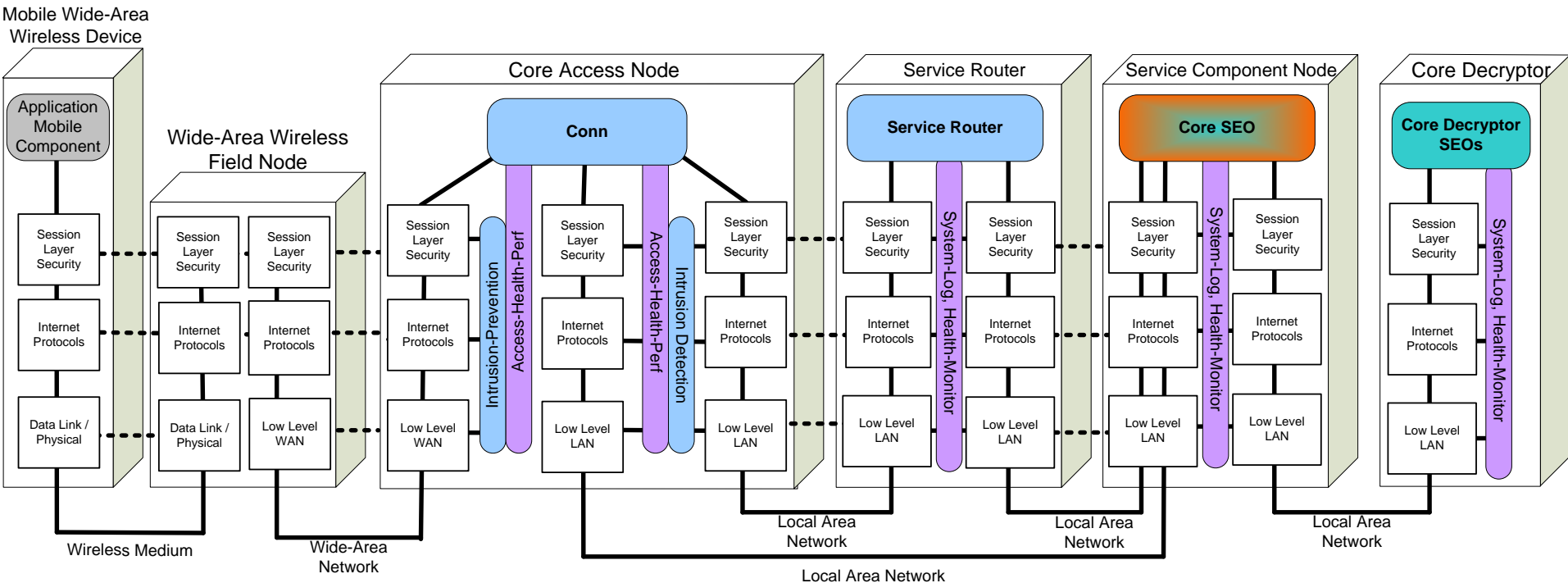

Communications View 4.4.2 – Mobile Wide-Area Wireless User and Core

Left Side

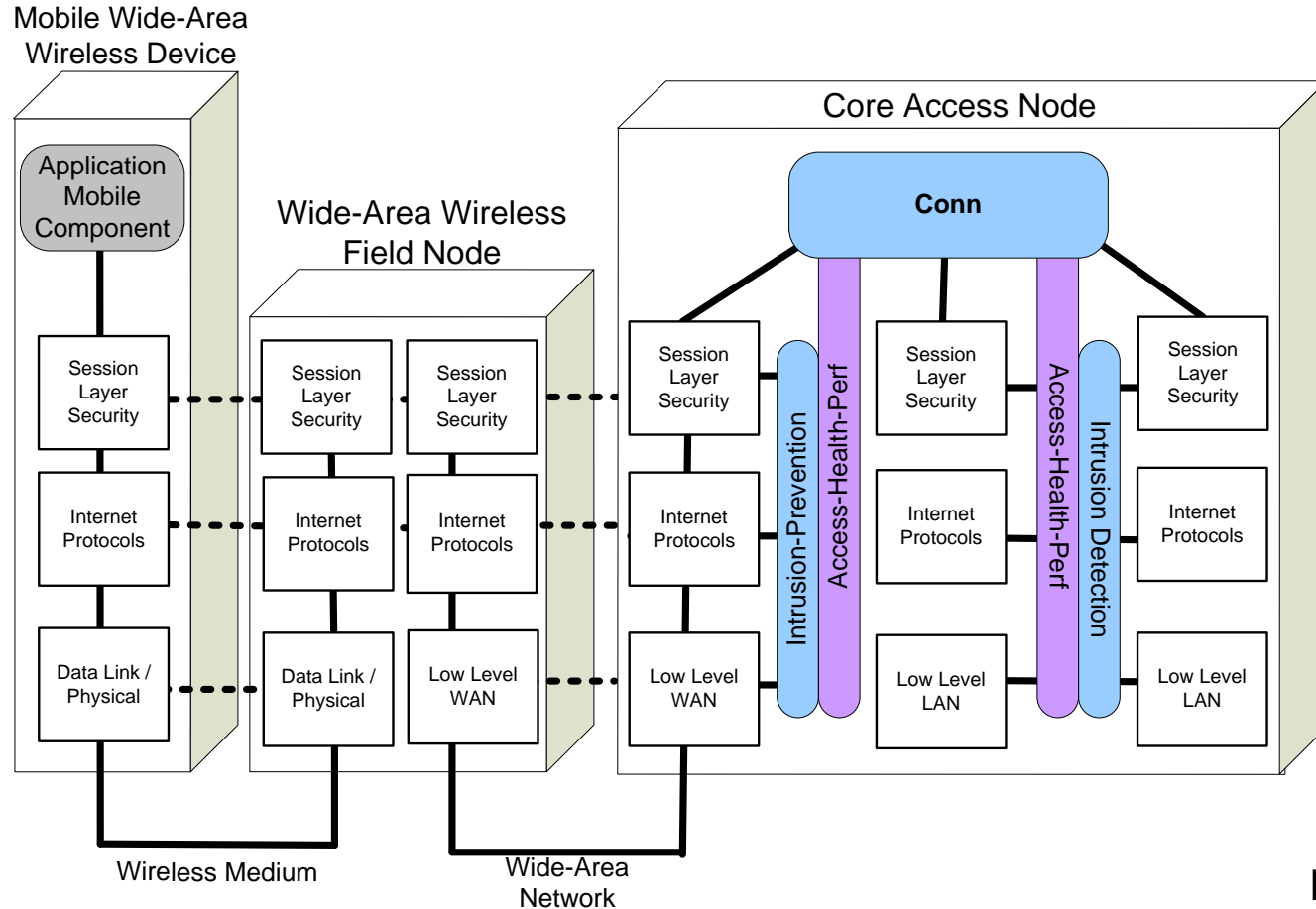

Right Side is same as DSRC view

Communications View 4.4.2 – Mobile Wide-Area Wireless User and Core

Related Views:

- Enterprise Views
 - Business Model
- Functional Views
 - Core Decryption
- Connectivity Views
 - High Level
 - Core System
Functional Allocation
- Communications Views
 - Mobile DSRC User and Core
 - Fixed Point Center/Field User and Core, Core2Core
 - Core Routing

Communications View 4.4.3 – Fixed Point Center/Field User and Core, Core2Core

- Description:
 - Shows how non-mobile systems (Field, Center, External Support Systems, and other Cores) communicate with the Core
 - Wired connections through the Internet or private networks
 - May use wireless (see 4.4.2)
 - Uses IP protocols

Communications View 4.4.3 – Fixed Point Center/Field User and Core, Core2Core

- Considerations/Concerns Addressed:
 - Performance
 - Interfaces
 - Functionality
 - Security
 - Organization/
Resources
 - Appropriateness
 - Feasibility
 - Risks
 - Evolvability
 - Deployability

Communications View 4.4.3 – Fixed Point Center/Field User and Core, Core2Core

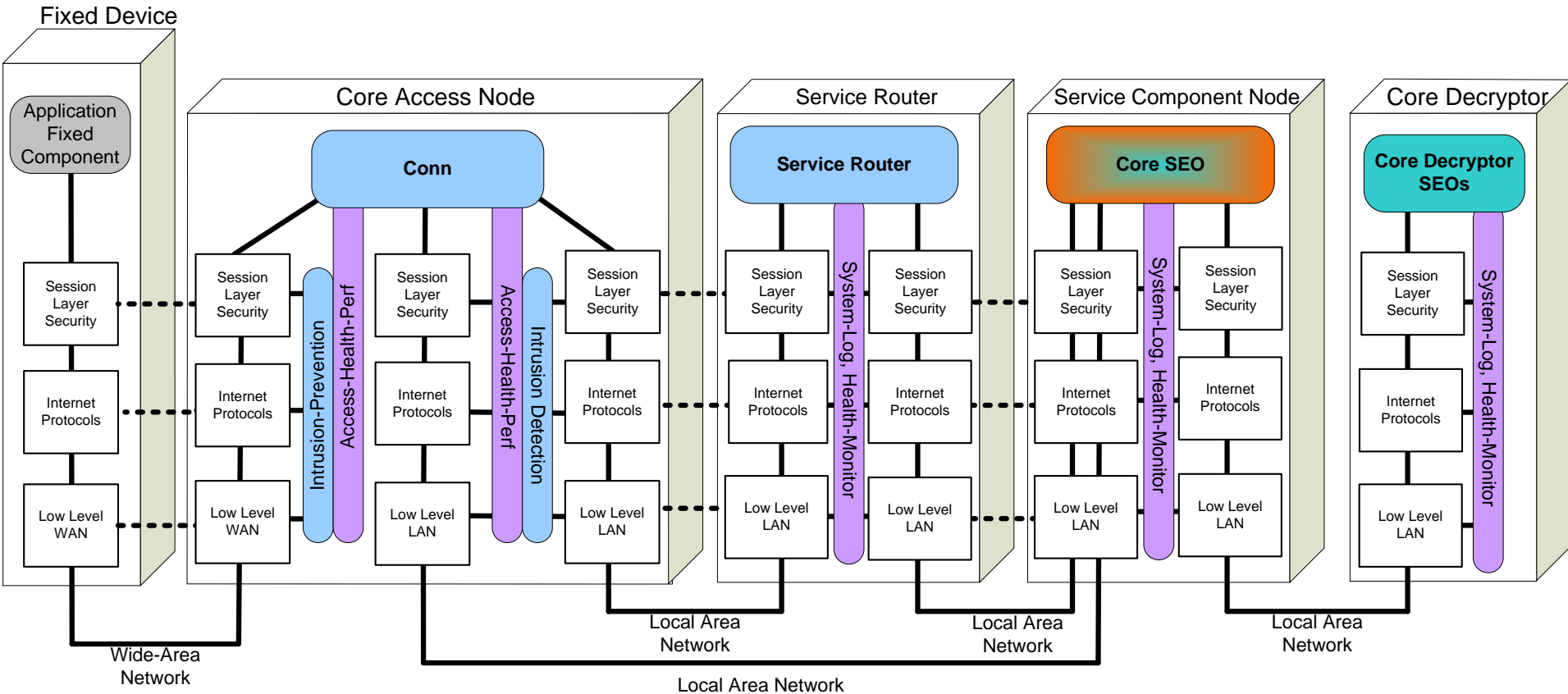

Communications View 4.4.4 – Core Routing

Related Views:

- Enterprise Views
 - Business Model
- Functional Views
 - Core Decryption
- Connectivity Views
 - High Level
 - Core System Functional Allocation
- Communications Views
 - Mobile DSRC User and Core
 - Mobile Wide-Area Wireless User and Core
 - Core Routing

Communications View 4.4.4 – Core Routing

- Description:
 - Shows the communications involved when the Core is used as a router when a private network is used to connect mobile, field, or center systems
 - Fixed devices connected to the Core by a private network can use the Core Access Node to provide connectivity between them
 - Could also provide connectivity for mobile users to a Center user

Communications View 4.4.4 – Core Routing

- Considerations/Concerns Addressed:
 - Performance
 - Interfaces
 - Functionality
 - Security
 - Organization/
Resources
 - Appropriateness
 - Feasibility
 - Risks
 - Evolvability
 - Deployability

Communications View 4.4.4 – Core Routing

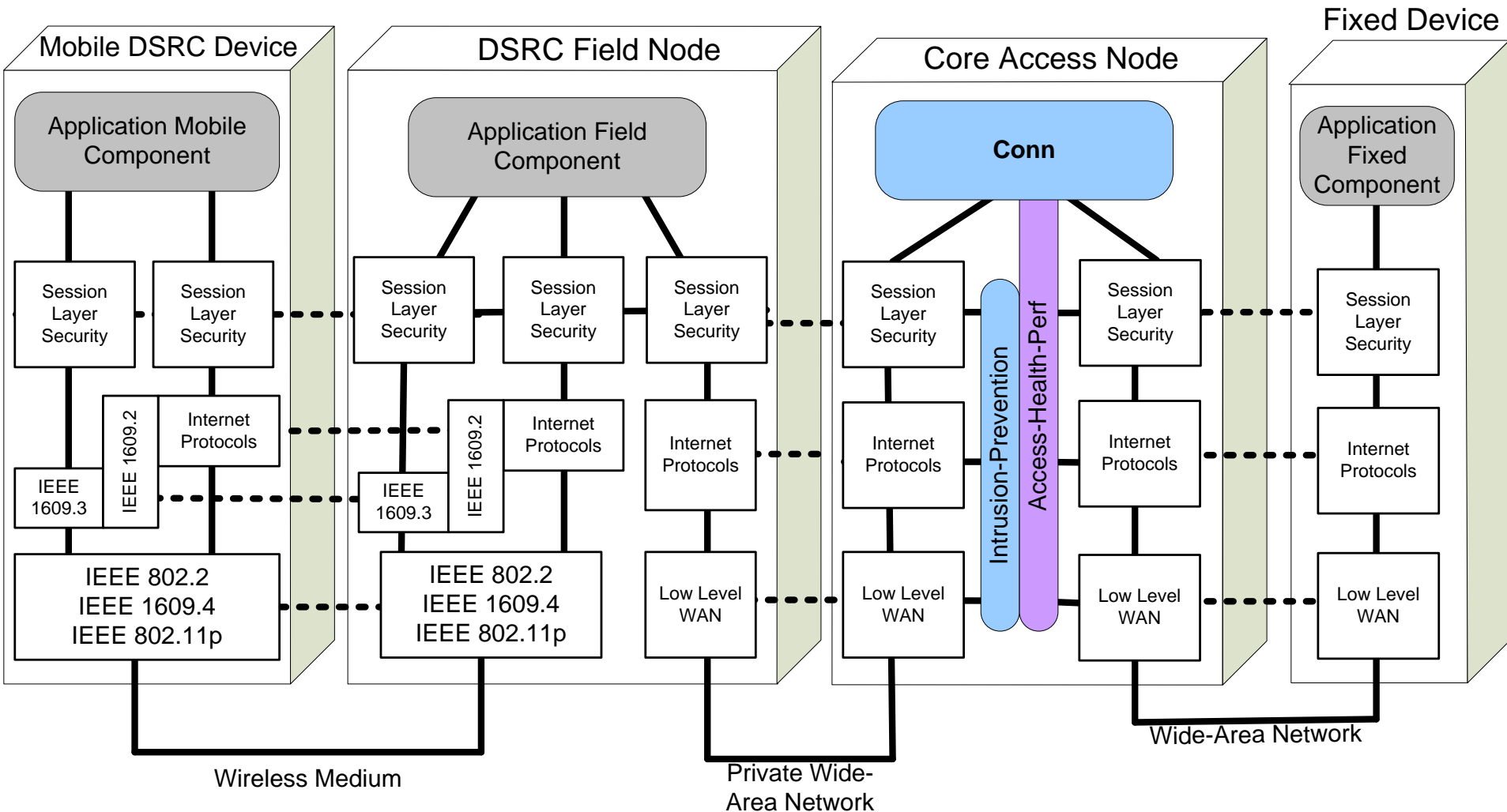

Figure 4-25: Communications View – DSRC Mobile over Private Network

Communications View 4.4.4 – Core Routing

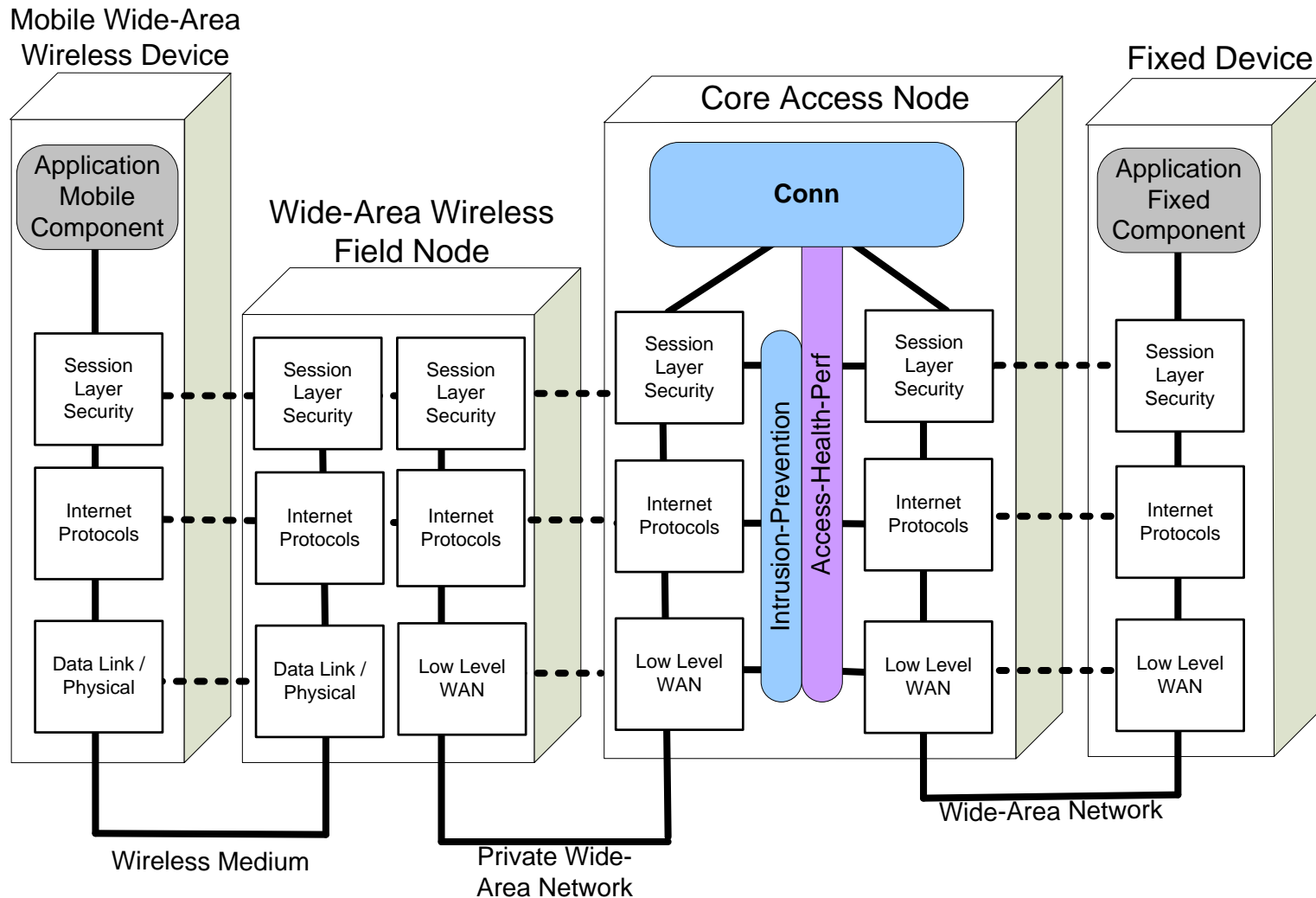

Figure 4-26: Communications View – Wide-Area Mobile over Private Network

Communications View 4.4.4 – Core Routing

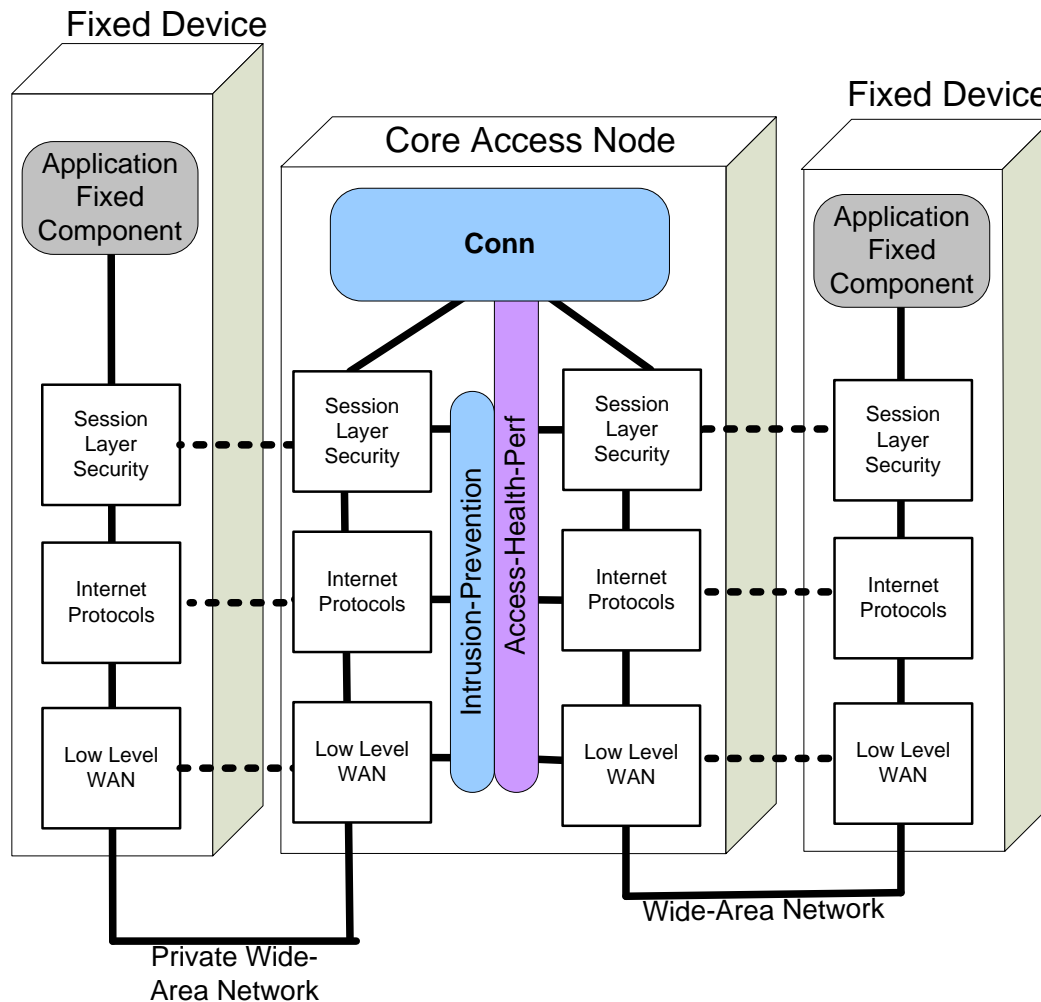

Figure 4-27: Communications View – Fixed Device over Private Network

Communications View 4.4.4 – Core Routing

Related Views:

- Enterprise Views
 - Business Model
- Functional Views
 - Core Decryption
 - Networking
- Connectivity Views
 - High Level
 - Core System Functional Allocation
- Communications Views
 - Mobile DSRC User and Core
 - Mobile Wide-Area Wireless User and Core
 - Fixed Point Center/Field User and Core, Core2Core

Core System Architecture: Information Views





Views that will describe the data object structures and relationships



Information

- Defines the Data objects: structure, relationships, metadata, and constraints
- Related to *interface* requirements, referenced by the *functional* requirements

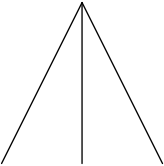
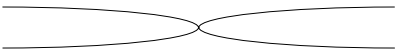
	Information Objects
	“part-of” relationship
	“aggregation” relationship
	“Transformation” relationship

Information Views Defined

- Top Level External Objects
- Top Level Internal Objects



Information View 4.5.1 – Top Level External Objects

- Description:
 - Objects that are exchanged, sent, and received over the Core System's external interfaces
 - Includes objects between Cores
 - Organized by the originating or terminating subsystem
 - External interfaces are candidates for standardization

Information View 4.5.1 – Top Level External Objects

- Considerations/Concerns Addressed:
 - Security
 - Interfaces
 - Appropriateness

Information View 4.5.1 – Top Level External Objects

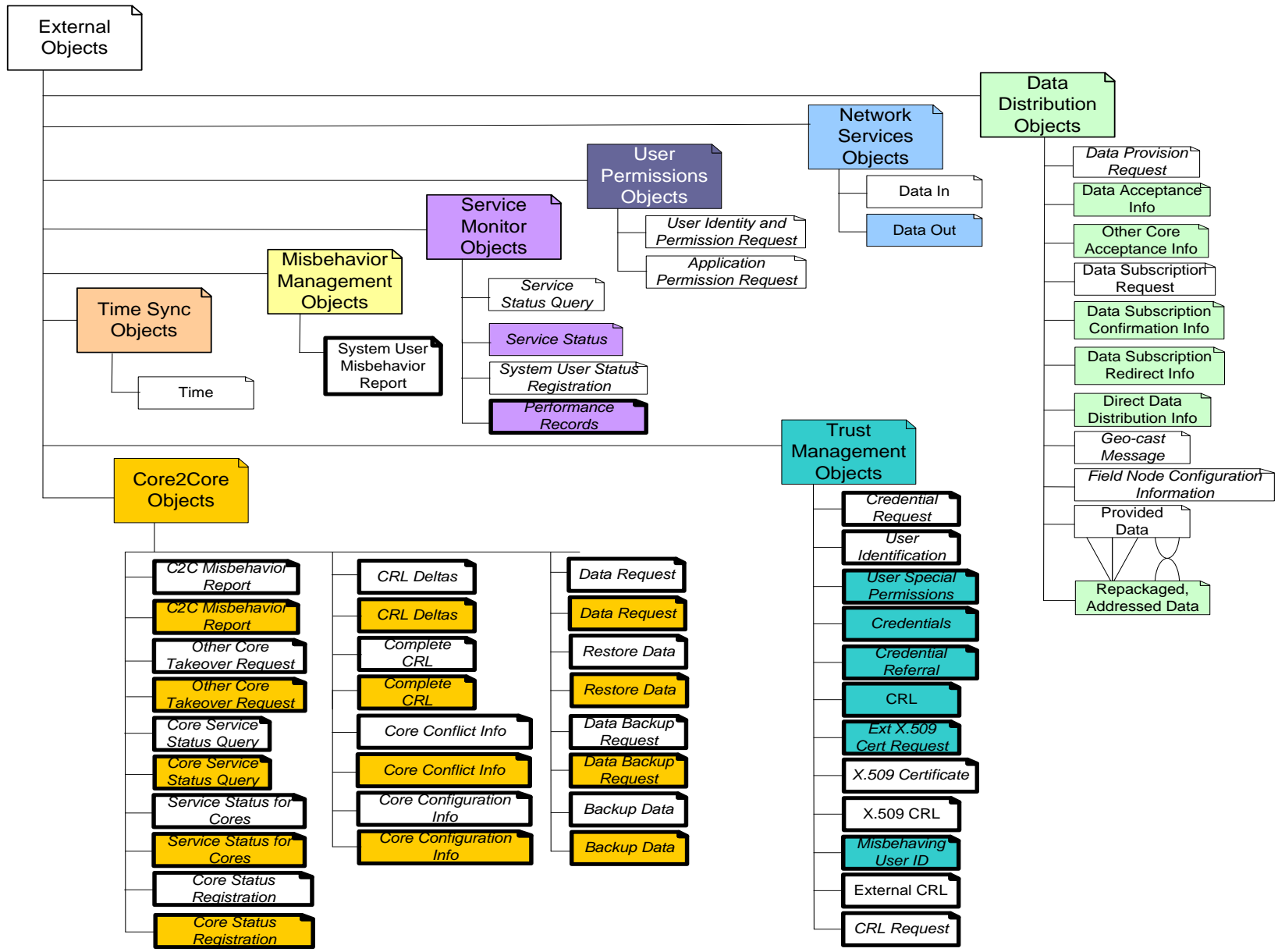

Information View 4.5.1 – Top Level External Objects

Related Views:

- Functional Views
 - Top Level
 - Data Distribution
 - System Configuration
 - User Configuration
 - System Monitor and Control
 - Credentials Distribution
- Misbehavior Management
- Core Decryption
- Networking
- Core Backup
- Information Views
 - Top Level Internal Objects

Information View 4.5.2 – Top Level Internal Objects

- Description:
 - Objects that are exchanged, accepted, and sent between subsystems over the Core System's internal interfaces
 - Organized by the originating or terminating subsystem

Information View 4.5.2 – Top Level Internal Objects

- Considerations/Concerns Addressed:
 - Security
 - Interfaces
 - Appropriateness

Information View 4.5.2 – Top Level Internal Objects

Related Views:

- Functional Views
 - Top Level
 - Data Distribution
 - System Configuration
 - User Configuration
 - System Monitor and Control
 - Credentials Distribution
- Misbehavior Management
- Core Decryption
- Networking
- Core Backup
- Information Views
 - Top Level External Objects

Core System Architecture: Deployment Options

»» How will the Core be 'rolled-out'

Core System Deployment

- Recall from Day 1's background of the Core System
 - Core System Needed
 - Support diverse implementations
 - Extensible, scalable over time
 - Support Diverse deployments
 - Standalone
 - Collocated
 - Distributed

Core System Deployment

- Core System Architecture supports those goals:
 - Enterprise Objects like Core Certification Authority
 - Interfaces like Core2Core
 - Ability to vary how software is assigned to nodes

Core System Coordination

- »» Deployment Considerations as multiple Cores are developed and fielded

Single Standalone Core

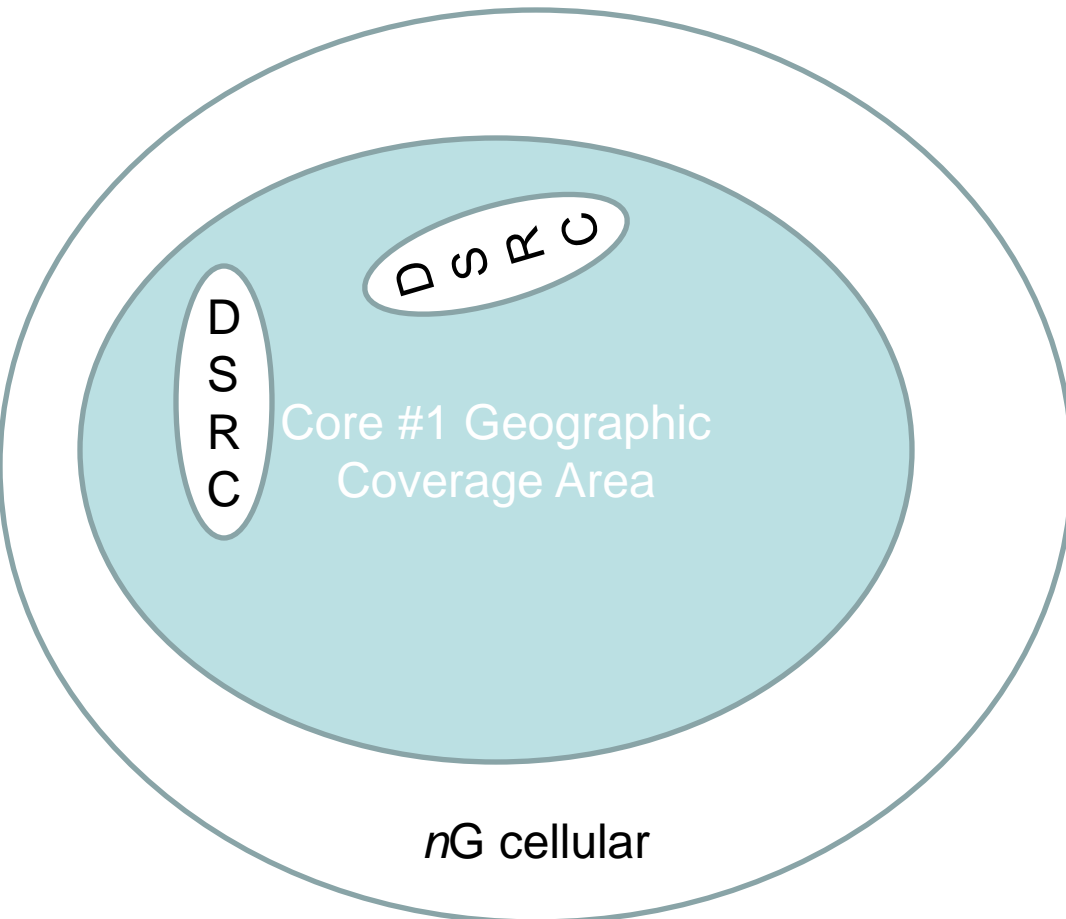

- Core #1 provides all services for the area. Some areas provide DSRC communications to Core, resulting in different service delivery profiles.

Multi Core – One Dominant

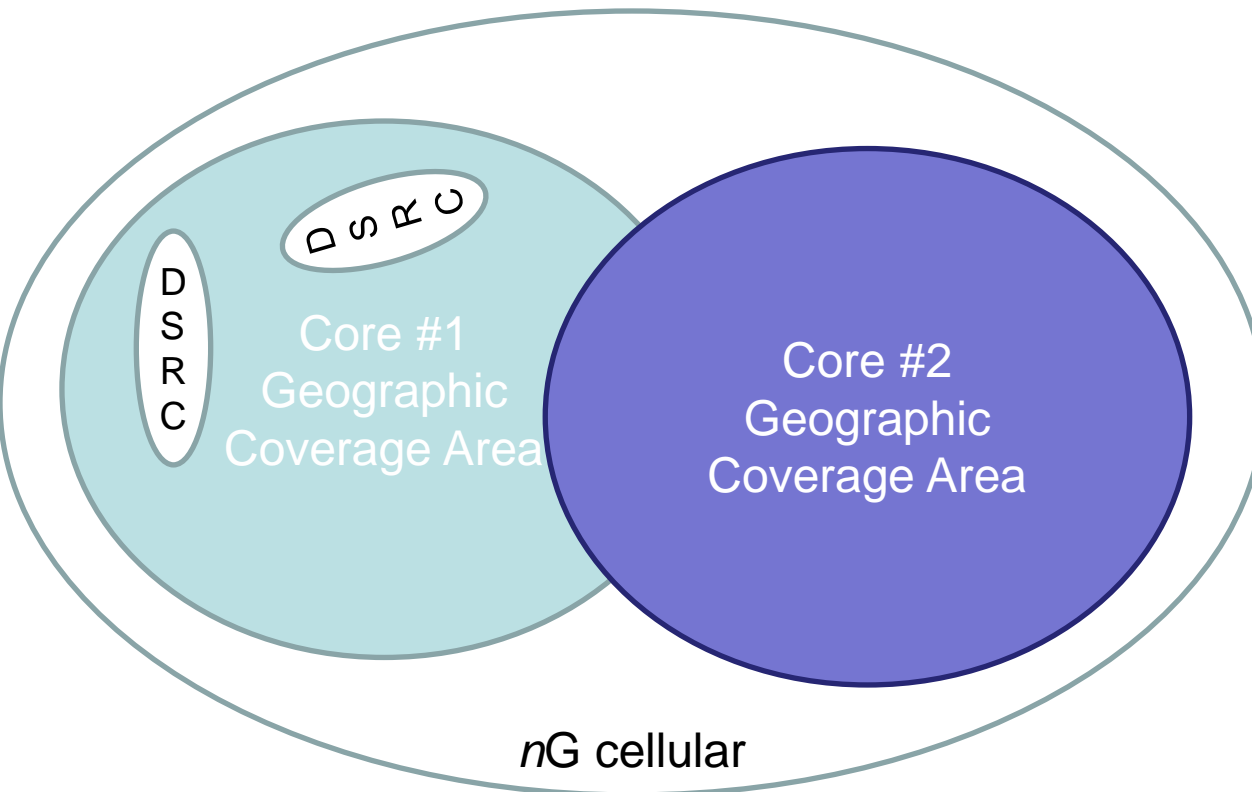

- Core #2 provides all services for the area it covers, all by *nG* cellular.
- Core #1 provides all services for the area it covers, some by *nG*, some by DSRC.
- Overlap requires agreement, and Core #2 provides services in the overlap areas here.

Multi Core – Shared Dominance

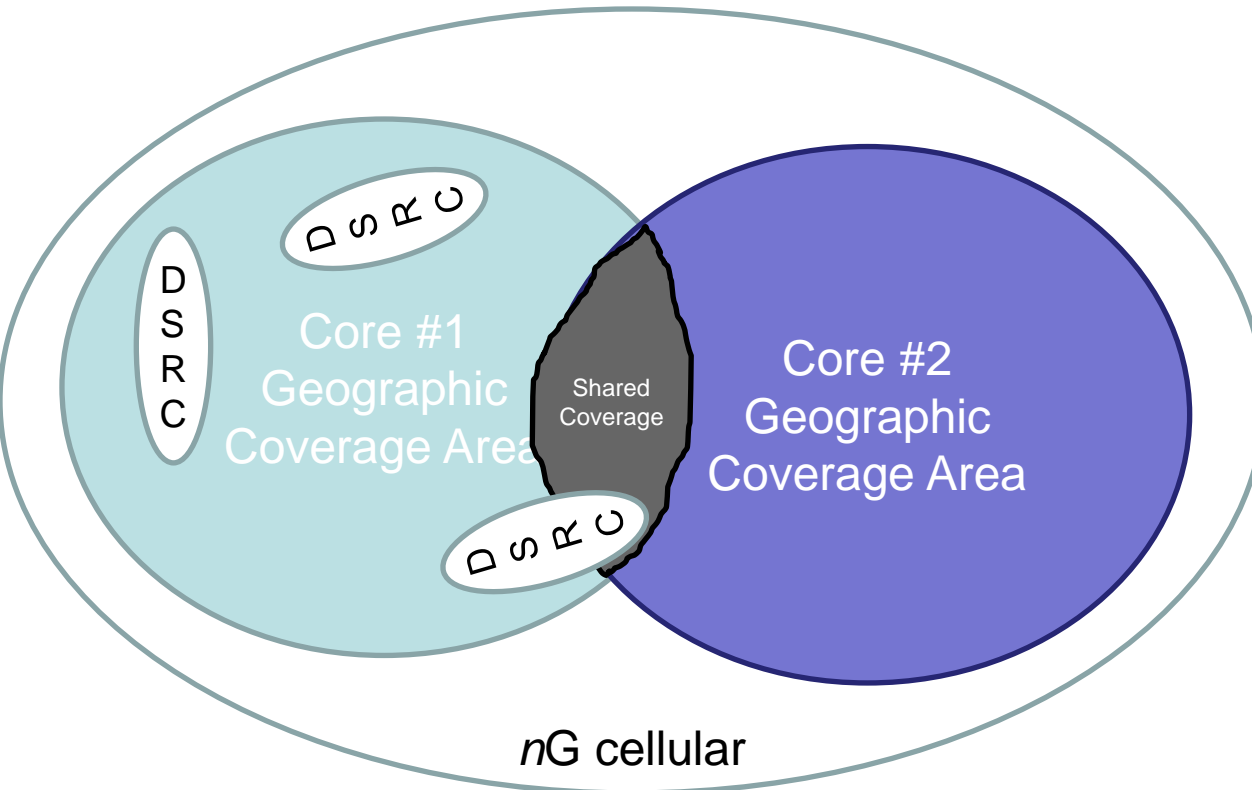

- Core #2 provides all services for the area it covers, all by *nG*, except for the shared area.
- Core #1 provides all services for the area it covers, some by *nG*, some by DSRC.
- Overlap requires agreement; Core #1 and Core #2 both provide services. Each service provided by only one Core, except for DSRC users that can get all services from Core #1.



Multi Core – Peers

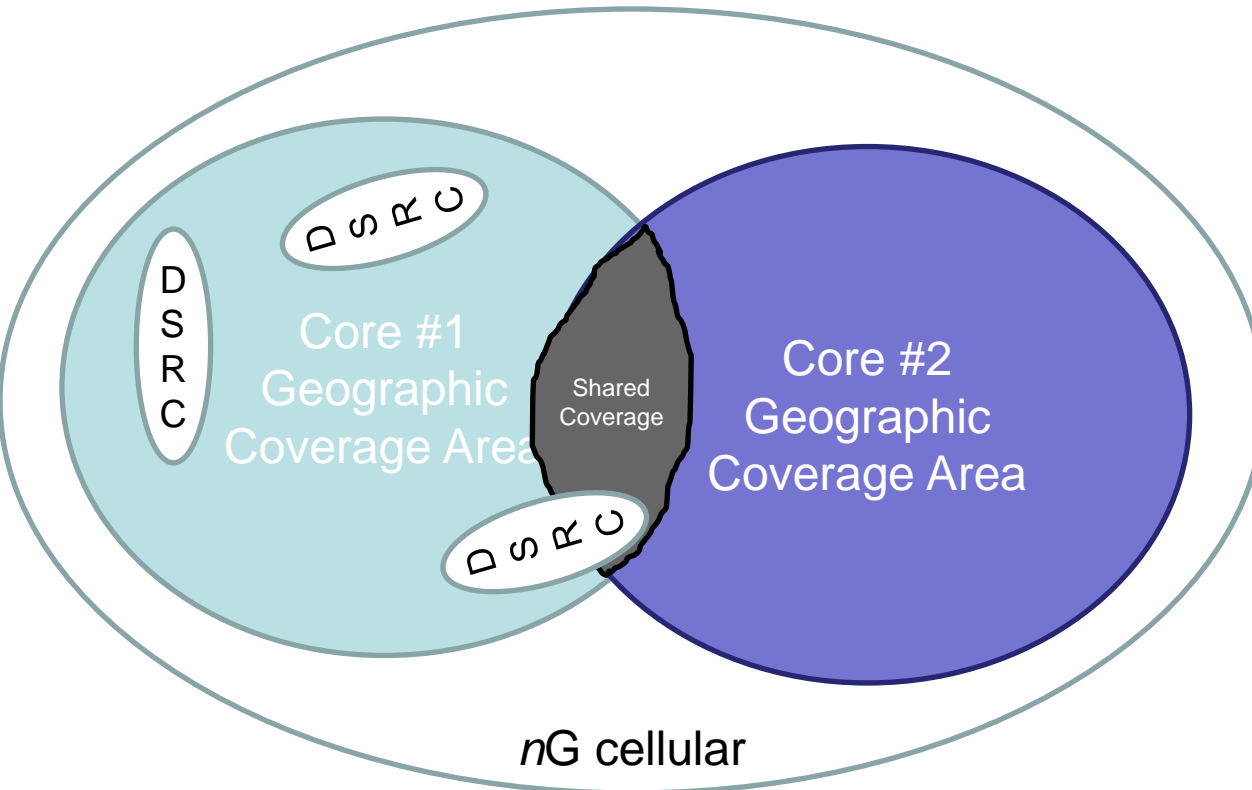

- Core #2 provides all services for the area it covers, all by *nG*, except for the shared area.
- Core #1 provides all services for the area it covers, some by *nG*, some by DSRC.
- Overlap requires agreement; Core #1 and Core #2 both provide services. Overlap area defaults to Core #2, except for DSRC users that go to Core #1. Users can override and access Core #1 with 3G if they wish



Core System Deployment Activities

- 1st Steps (take care of the higher risk items)
 - Setup the Core Certification Authority to establish:
 - Governance policies
 - Certification standards and procedures
 - Security credentials (root CA)
 - Establish the External Support Systems (the CAs and RAs)

Core System Deployment Activities

- Incorporate Lessons from Test Bed, Safety/Certification Pilots
- Work with Standards organizations to incorporate Core System interfaces into industry standards
- Begin to work with Deployers to establish operating agreements
- What else?

Discussion – Likely Deployers

- Who is likely to deploy a Core System?
 - States
 - Locals
 - 3rd Party Data Warehouse Providers
 - System Integrator
 - Auto Industry
- May affect how relationships are defined by the Core Certification Authority

Core System Risks

»» Barriers to Deployment

Risk to Success of the Core System

- What may happen to prevent the Core System from succeeding – and to some extent, affect the overall *connected vehicle* environment
- Types of Risks
 - Technically – Core System is straightforward, using current technologies
 - Institutional Issues always take longer
 - Programmatic – cost/schedule
- Levels: individual Core, collectively

Preliminary Risks to Success of the Core System

- Timely Deployment
- Relationships between Core Systems and external Enterprises
- Role and Makeup of the Core Certification Authority
- External Support System (ESS) for Security
- Operations and Maintenance of the Security External Support System (ESS)
 - More for the *connected vehicle* environment
- Security Management
- Data Provisioning/Ownership



Next Steps

»» For Core System and related activities

Core System Timeline

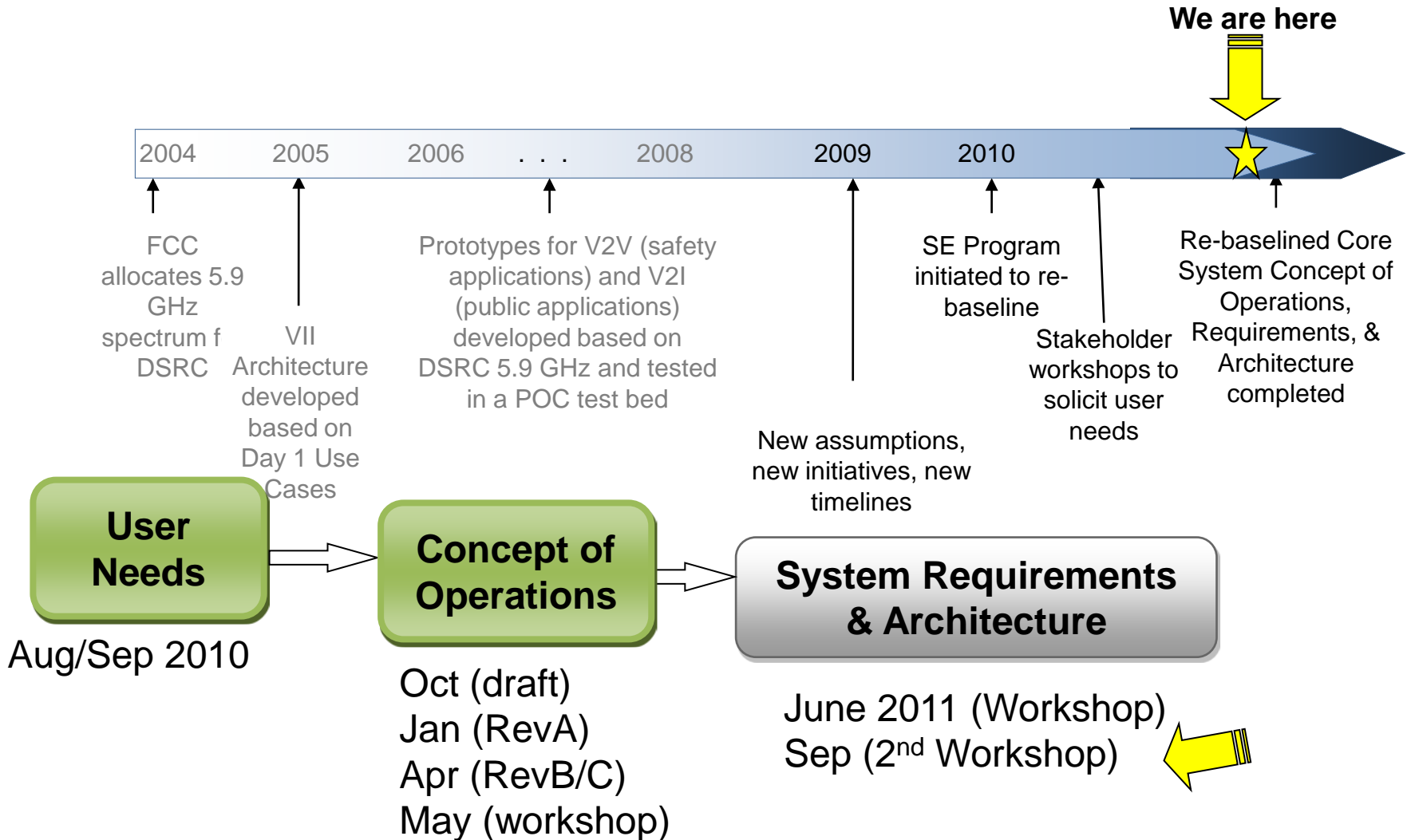

Next Steps

- System Engineering Team will finalize
 - ConOps
 - Requirements
 - Architecture
 - Risk
 - Standards Recommendations
- DOT leading other activities where Core System
- Contact Walt Fehr – 202-366-0278,
walt.fehr@dot.gov

End of Day 3

»» Thank you all for your Time