

# **RERTR 2012 — 34<sup>th</sup> INTERNATIONAL MEETING ON REDUCED ENRICHMENT FOR RESEARCH AND TEST REACTORS**

**October 14-17, 2012  
Warsaw Marriott Hotel  
Warsaw, Poland**

## **Evaluation of Fuel Plate Integrity during a Fuel Assembly Drop Accident Using an Energy Method**

J.S.Yim, H.J.Kim, Y.W.Tahk, J.Y.Oh, and B.H.Lee  
Nuclear Fuel Design for Research Reactor  
Korea Atomic Energy Research Institute (KAERI)  
989-111 Daedeok-daero, Yuseong-gu, Daejeon, 305-353, Korea

### **ABSTRACT**

Considering the drop height in the pool of a fuel assembly (FA) drop accident during fuel handling, the number of fuel plates (FPs) failed in either the dropping FA or standing FA in the core is estimated using an energy method. By way of balancing the forces among FA weight, buoyance, and hydraulic drag force, the impact velocity of the falling FA is calculated. Equating the kinetic energy to the strain energy stored in an FP, the stress exerted in the FP is obtained and compared with the stress limits to predict the number of failed FPs.

The horizontal and vertical drop modes of an FA are taken into consideration. For each case, one FA drop inside or outside the core is considered, respectively. In the case of an FA drop outside the core, the drop height will be the highest, and thus the stress in a plate will be at maximum for both cases of the plate in-plane vertical impact on the floor and in-plane horizontal impact. When an FA drops inside the core, it impacts the fixing bars first at the top of the standing FA in the core. For the conservativeness of the analysis, it was assumed that one of the two fixing bars is directly impacted, and it is evaluated whether this bar can withstand the kinetic energy of the dropping FA.

The evaluation shows that none of the FPs failed in the FA drop accidents for all cases considered above. The fixing bar of the standing FA in the core is also predicted to remain intact after being hit by the dropped FA.

### **1. Introduction**

When the structure of an FA is newly designed or changed differently compared to those of the previous structure, the integrity of the FA and FPs should be checked or confirmed to be within the limits especially under certain accident conditions. KAERI has designed a box-type FA, which is a little bit different from those of previous FAs in that the two side plates of the FA are fixed by two fixing bars apart from each other instead of using one bar at the top of the FA. To minimize the flow disturbance under the fixing bars, the bars have a smaller diameter than that of a single handling bar.

This design modification provides much easier and firmer FA gripping with minimizing an FA swing during FA handling. Although the fuel handling tool is equipped with a double locking device to protect from disengaging the FA, an FA is assumed to be dropped accidentally during handling for the loading or unloading in the core, as is classified by a postulated accident. When an FA drops, it can either hit the floor or impact the other FAs in the core. As a consequence of an impact by a dropping FA, the FPs in either dropped FA or impacted FA can be damaged, which may cause a release of radioactive material from the fuel plates to the coolant. Since there have been few assessments of FP integrity relevant to the FA drop accidents, an approach by way of the energy method is made in this paper.

For the numerical calculation, an example case is taken with a pool depth of 10 m, an underwater depth of an FA 3.9 m, and an FA height of 1.015m. The possible drop height of FA in the pool is first calculated from the values above. By way of a force balance between the FA weight, buoyance, and hydraulic drag force, the velocity of a falling FA is calculated [1]. Equating the kinetic energy to the strain energy stored in an FP, the stress exerted in the FP is obtained and compared with the stress limits to predict whether the FPs have failed.

The horizontal and vertical drop modes of an FA are taken into consideration for both cases: FA drops inside and outside the core.

When an FA drops inside the core, it impacts the fixing bars first at the top of the FA standing in the core if the loaded FAs exist. To take into consideration a conservatism of the analysis, only one of the two fixing bars is considered to be entirely impacted and estimated whether this bar can bear the kinetic energy of a dropping FA or not.

In the calculation of the stored energy in an FP, the elastic strain is used for simplicity and conservatism since it is well known that the dynamic yield stress is much higher than the static yield stress [2]. If the stress goes beyond the stress limit, the plasticity shall be included in the analysis.

When an FA drops outside the core, the drop height of the FA becomes the highest by 5.085 m. The drop height to reach the terminal velocity obtained from the force balance is 17 m, and thus the impact velocity of the FA drop outside the core will be less than the terminal velocity. Therefore, the impact velocity is used in the calculation of the kinetic energy of an impacting FP.

## **2. Calculation**

### **2.1 Material Properties and Stress Limits**

The material properties and stress limit are tabulated in Table 1. In determining the stress limits of the materials for the FA and FPs, the un-irradiated material yield strength is used since it increases slightly as the irradiation continues. The stress categories and stress limits presented in the KEPIC MN [3] (or ASME Section III [4]) are used as a general guide in the evaluation of fuel plate integrity at the FA drop accident. They are listed in Table 2.

### **2.2 FA Drop Velocity**

A fuel handling tool is designed to preclude an FA drop accident by means of a double locking mechanism. Even if the fuel handling tool is designed such that it shall never release an FA inadvertently by a double protection mechanism, an FA drop accident is regarded as a postulated accident for the dose analysis in the reactor site. When an FA drops in the pool, it can be divided into 2 main aspects in view of the drop direction, the vertical (Fig. 1 (a)) or horizontal direction of the FA (Fig. 1 (b)). The latter drop case also splits into two different cases; FP impacts on the in-plane direction (Fig. 1(b-i)), and FP impact on the out-of-plane direction (Fig. 1(b-ii)), respectively. Other than an FA drops vertically or horizontally, an FA can drop to impact on the floor at a skewed angle, or impact vertically, and then rotate to impact horizontally (Fig. 1(c)). These cases are considered to

be encompassed by the vertical or horizontal drop cases since the energy at impact for these cases is less than for vertical or horizontal impact cases.

**Table 1. Material Properties**

| Material               | Density(Kg/m <sup>3</sup> ) | Young's Modulus(GPa) |
|------------------------|-----------------------------|----------------------|
| Fuel Meat              | 6600                        | 72.7                 |
| Cladding (AG3NE)       | 2700                        | 69.3                 |
| Fixing bar (Al6061 T6) | 2700                        | 70.4                 |

**Table 2. Stress Limits**

| Stress Categories and Limits                  | Value(MPa)      |           |
|---|-----------------|-----------|
|   | Cladding(AG3NE) | Al6061 T6 |
| Pm <sup>*)</sup> < Min. (2.4Sm or 0.7 Su)     | 126             | 203       |
| Pm+Pb <sup>*)</sup> < Min. (3.6Sm or 1.05 Su) | 189             | 304.5     |

\*) Pm : primary membrane stress, Pb : primary bending stress, Sm : stress intensity, Su : Ultimate tensile stress

The drop height of an FA in the core can be calculated considering the handling modes. When an FA drops in the pool, the impact velocity varies from its original position in the pool at the handling gripper. The final velocity (terminal velocity) of the dropping FA can be calculated using the force balancing exerted on the FA as:

$$(m - \rho V)g - F = (m + m_a) \frac{dv}{dt}, \quad (1)$$

where,  $m_a$  is the added mass on the FA,  $\rho$  is the density of the fluid,  $t$  is the time,  $V$  is the FA volume,  $g$  is the acceleration of gravity, and  $F$  is the drag force. The drag force is written as

$$F = \frac{1}{2} \rho A C_D v^2, \quad (2)$$

where,  $C_D$  is the drag coefficient,  $v$  is the velocity of the FA, and  $A$  is the orthographic projection of the FA on a plane perpendicular to the direction of motion. As the velocity of the FA increases, the resisting drag force also increases. The differential equation (1) is rearranged as

$$\int_0^v \frac{dv}{(m - \rho V)g - \frac{1}{2} \rho A C_D v^2} = \frac{1}{m + m_a} \int_0^t dt. \quad (3)$$

Solving this differential equation, the velocity of a falling FA becomes

$$v(t) = \sqrt{\frac{(m - \rho V)g}{\frac{1}{2} \rho A C_D}} \tanh \left( t \sqrt{\frac{(m - \rho V)g \cdot \frac{1}{2} \rho A C_D}{m + m_a}} \right). \quad (4)$$

Using the velocity in water obtained from equation (4), the impact velocity can be calculated as a function of the drop height. As an example of the application of this approach, the numerical values taken are as mentioned in section 1: The pool depth is 10 m, the location of the FA is 3.9 m from the pool surface, the FA height is 1.015 m. Using the possible drop height in the pool during FA handling, the velocities at impact for various FA drop modes are summarized in Table 3.

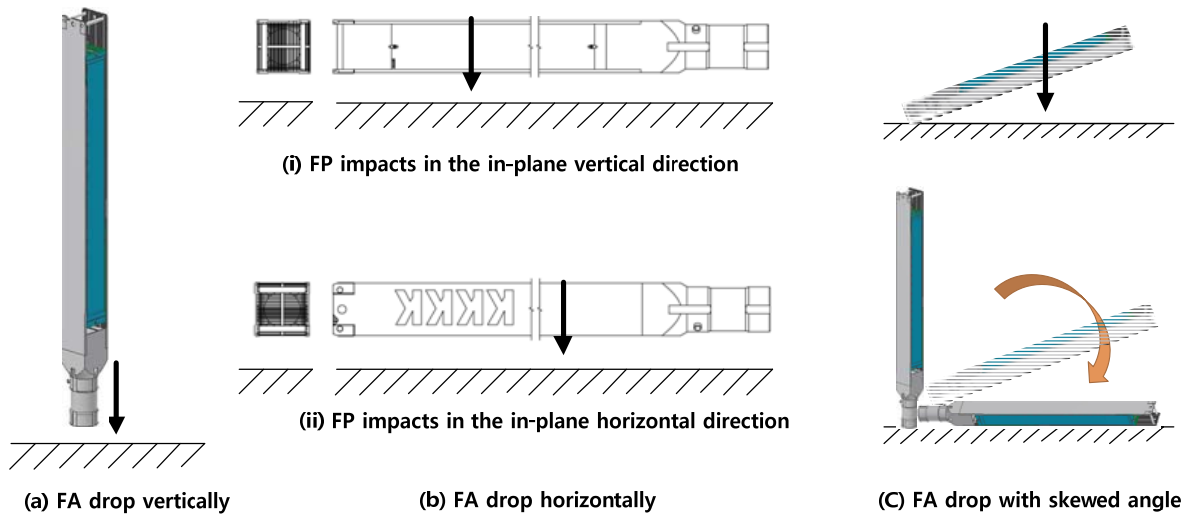

**Figure 1. FA drop modes**

**Table 3. Maximum drop height and impact velocity**

| FA drop mode | FA drop cases  | Maximum drop height(m) | Impact velocity (m/sec) |
|--------------|--|------------------------|-------------------------|
| Horizontal   | inside core  | Not occur              | -                       |
|              | outside core<br>- FP drops on the in-plane direction     | 5.087                  | 0.96                    |
|              | outside core<br>- FP drops on the out-of-plane direction | 5.087                  | 0.96                    |
| Vertical     | inside core  | 3.16                   | 4.0                     |
|              | outside core   | 5.087                  | 4.58                    |

## 2.3 FA horizontal drop

### 2.3.1 FA drops inside core

The dimension of the core entrance is small, which leads to the falling FA being unable to enter the core. Therefore, this case is ruled out.

### 2.3.2 FA drops outside core

The highest attainable impact velocity of this drop mode for an FA is 0.96 m/sec. In this case, the FP can impact the floor in the in-plane direction (Fig. 1 (b-i)) and the out-of-plane direction (Fig. 1 (b-ii)). When an FP impacts the floor in the in-plane direction, the stress can be calculated by equation (5) below [5].

$$\sigma = v\sqrt{\rho E} \quad (5)$$

On the contrary, if the FPs impact in the out-of-plane direction on the floor, the moment exerted at the edge of the plate owing to a clamped boundary condition, which causes bending stress, can be calculated as follows [6]:

$$\frac{1}{2}mv^2 = \frac{M^2l}{2EI} \quad (6)$$

$$\sigma = \frac{Mc}{I} \quad (7)$$

The moment calculated at the edges of an FP is 5.11 Nm, and the bending stress on the dropping FP is 27.94 MPa, which is far below the stress limit. The calculated stresses for the various drop cases and limits are tabulated in Table 4.

## 2.4 FA vertical drop

### 2.4.1 FA drops outside the core

When an FA drops outside the core, the maximum attainable velocity of impact on the floor is 4.58 m/sec, which is lower than the terminal velocity of 5.36 m/sec. In this case, the FP is assumed to impact the floor at the same velocity of the falling FA, and the kinetic energy of the FP is wholly absorbed in the FP without a loss of energy at the moment of impact. By equating the kinetic energy to the elastic strain energy stored in the FP, the stress in the FP can be computed using the same equation (5), from which the stress in the FP becomes 78.06 MPa.

### 2.4.2 FA drops inside core

The stress in the FP for this drop mode can also be calculated using equation (5) by simply replacing the impact velocity. The end fitting diameter is larger than the space between the two fixing bars, as shown in Fig. 2 (a), such that the end fitting hardly impacts the FP directly. Instead, the falling FA impacts the fixing bars first at the top of the standing FA in the core (see Fig. 2 (b)) and if the bar is broken, impacts of an FA on the FP will ensue. For this reason, the energy absorption in the fixing bar shall be estimated in advance to know whether the fixing bar will be broken. In the calculation, it is assumed that only one of the two bars is entirely hit by the falling

FA for the conservativeness. Even though the behaviors between a static and dynamic impact are quite different, a static stress-strain curve as shown in Fig. 3, excerpted from reference [7], is used in the calculation of energy absorption. This preserves greater conservativeness since the dynamic yield stress is apparently much higher than the static yield stress [2].

The possible strain energy stored in a fixing bar by an FA impact is calculated as 209 Nm using the stress-strain curve up to strain rate of 0.18, while the kinetic energy of an FA with an impact velocity of 4.0 m is 42.9 Nm. Thus, the fixing bar can bear enough impact energy imposed by a falling FA, and further impact on the FPs will not occur. Thus, it is not necessary to calculate the stress of FPs in a standing FA because the fixing bar protects the dropping FA from direct impact the FPs of the standing FA.

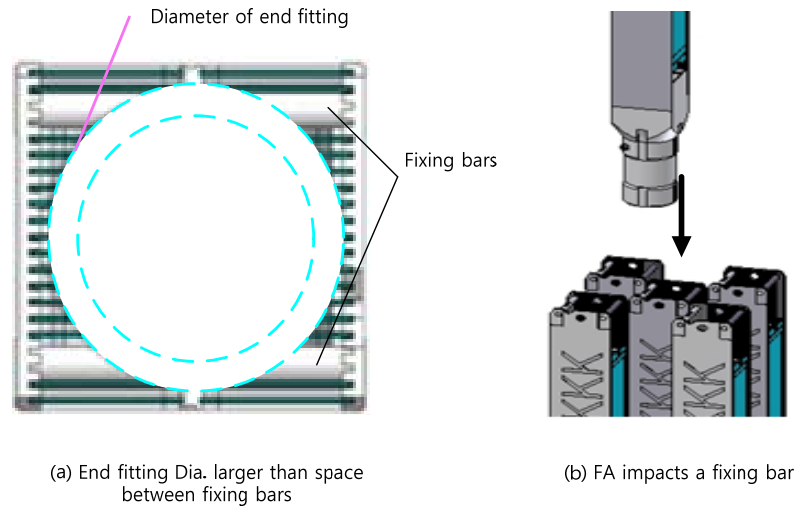

**Figure 2. FA drop inside core**

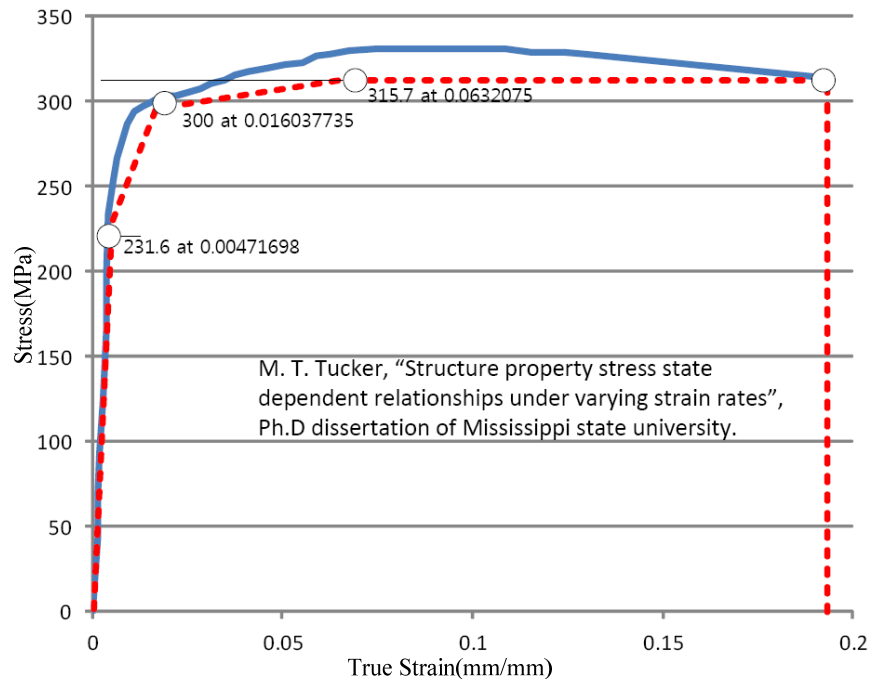

**Figure 3. Stress-strain curve for Al-6061 T6**

**Table 4. Stress results and its limits at FA drop modes**

| FA drop mode | FA drop cases                            | Stress(MPa) or Energy(Nm)                      | Limits                        |
|--------------|--|--|-------------------------------|
| Horizontal   | inside core                              | not occur                                      | -                             |
|              | outside core<br>- FP in-plane vertical   | FP membrane stress<br>16.36 MPa                | less than 2.4 Sm<br>= 126 MPa |
|              | outside core<br>- FP in-plane horizontal | FP membrane and bending<br>stress<br>27.94 MPa | less than 3.6 Sm<br>= 189 MPa |
| Vertical     | inside core                              | Storable Energy in a Fixing<br>bar 209 Nm      | Larger than 42.9 Nm           |
|              | outside core                             | FP membrane stress 78.06<br>MPa                | less than 2.4 Sm<br>= 126 MPa |

### 3. Conclusion

When an FA drops accidentally in the pool during fuel handling, the FPs can be broken, which causes the fission products to release into the coolant and environment. To estimate the number of failed FPs in such an FA drop accident, the stresses in the FP are calculated using an energy method. Vertical and horizontal FA drop cases were considered, and in each case, FA drops inside and outside the core are also considered separately.

The evaluation shows that even though the elastic strain range is used in the calculation of the stored energy, none of the FPs failed during an FA drop accident for all cases considered above. The fixing bar of the standing FA in the core is predicted to remain intact after being hit by the dropping FA, which indicates that none of the FPs failure will occur under an FA drop accident with the exemplified condition considered here.

### 4. References

- [1] Sighard F. Hoerner, "Fluid-Dynamic Drag", Hoerner Fluid Dynamics, Brick Town, N.J., USA, 1965.
- [2] Jonesm N., Structural Impact, Cambridge University press, Cambridge, England, 1989.
- [3] Korea Electric Power Industrial Code, KEPIC, 2005 edition
- [4] ASME Boiler and Pressure Vessel Code, Section III, 2004 edition.
- [5] A.C.Ugural, S.K.Fenster, Advanced Strength and Applied Elasticity, 2<sup>nd</sup> edition.
- [6] S.P.Timoshenko, J.N.Goodier, Theory of Elasticity, Mcgraw-hill book co., 3<sup>rd</sup> ed.
- [7] M. T. Tucker, "Structure property stress state dependent relationships under varying strain rates", Ph.D dissertation of Mississippi state university.