

**RERTR 2012 — 34rd INTERNATIONAL MEETING ON
REDUCED ENRICHMENT FOR RESEARCH AND TEST REACTORS**

**October 14-17, 2012
Warsaw Marriott Hotel
Warsaw, Poland**

Recent Accomplishments in the Irradiation Testing of Engineering-Scale Monolithic Fuel Specimens

N.E. Woolstenhulme*, D.M. Wachs, M.K. Meyer, H.W. Glunz, and R.B. Nielson
Idaho National Laboratory
P.O. Box 1625, Idaho Falls, ID 83415 – USA
*Corresponding Author, Nicolas.Woolstenhulme@inl.gov

ABSTRACT

The US fuel development team is focused on qualification and demonstration of the uranium-molybdenum monolithic fuel including irradiation testing of engineering-scale specimens. The team has recently accomplished the successful irradiation of the first monolithic multi-plate fuel element assembly within the AFIP-7 campaign. The AFIP-6 MKII campaign, while somewhat truncated by hardware challenges, exhibited successful irradiation of a large-scale monolithic specimen under extreme irradiation conditions. The channel gap and ultrasonic data are presented for AFIP-7 and AFIP-6 MKII, respectively. Finally, design concepts are summarized for future irradiations such as the base fuel demonstration and design demonstration experiment campaigns.

1. Introduction

The National Nuclear Security Agency Global Threat Reduction Initiative Convert program employs the Fuel Development (FD) team in order to mature Low-Enriched Uranium (LEU) fuel technology necessary for conversion of High Power Research Reactors (HPRR's)^[1]. The FD team has overseen design, fabrication, irradiation, and examination of numerous tests on specimens containing this fuel design^[2]. The majority of these tests occurred in the Reduced Enrichment for Research and Test Reactors (RERTR) series irradiation campaigns in reflector experiment positions in the Advanced Test Reactor (ATR). These used smaller “scientific-scale” specimens to facilitate greater throughput of various specimen types and irradiation conditions. Data from these campaigns gave way to preferential testing of U-Mo fuel designs including larger “engineering-scale” specimens in the ATR Full-size plate In flux trap Position (AFIP) series of irradiation tests. The FD team is currently focused on maturation of the “Base Monolithic Design” which consists of uranium-10 wt% molybdenum alloy (U-10Mo) in the form of a monolithic foil, with thin zirconium interlayers, clad in aluminum by hot isostatic press^[3] as seen in Figure 1. Recent irradiation of the AFIP-7 and AFIP-6 MKII experiments was undertaken in order to exhibit engineering-scale fuel performance phenomena of the Base Monolithic Design.

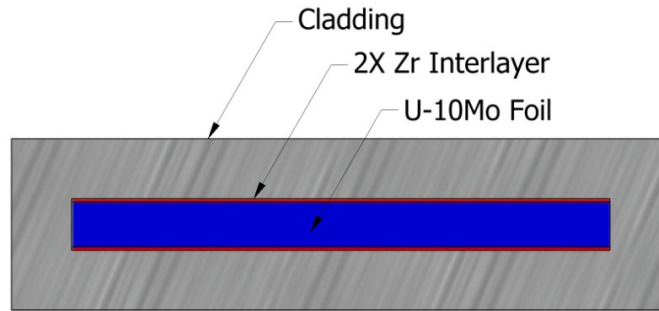

Figure 1: Base Monolithic Design

2. AFIP-7

The AFIP-7 experiment was designed to evaluate the performance of the Base Monolithic Design, composed of U-10Mo at 19.75 wt% U-235 enrichment, with prototypic-scale fuel plates constrained in a multi-plate fuel element array^[4]. It had been observed during flat-plate experiments that the natural constraint of the fuel meat in the transverse and axial directions is sufficient to force a vast majority of the fuel swelling to be manifest in only the thickness direction. The AFIP-7 experiment was to be used to confirm this behavior for curved plates and to evaluate any second-order buckling phenomena. The fuel element consisted of four total fuel plates, each measuring 6.28 cm wide \times 101.60 cm long \times 0.13 cm thick with a monolithic fuel meat 5.49 cm wide \times 97.79 cm long \times 0.033 cm thick. Each fuel plate was curved to a radius of 9.03 cm in the transverse direction and roll-swaged into aluminum side plates along the axial plate edges^[5]. This assembly employed several design features based on existing designs for HPRR driver fuel elements such as combs, end fittings, and pressure equalization vents^[6] as seen in Figure 2.

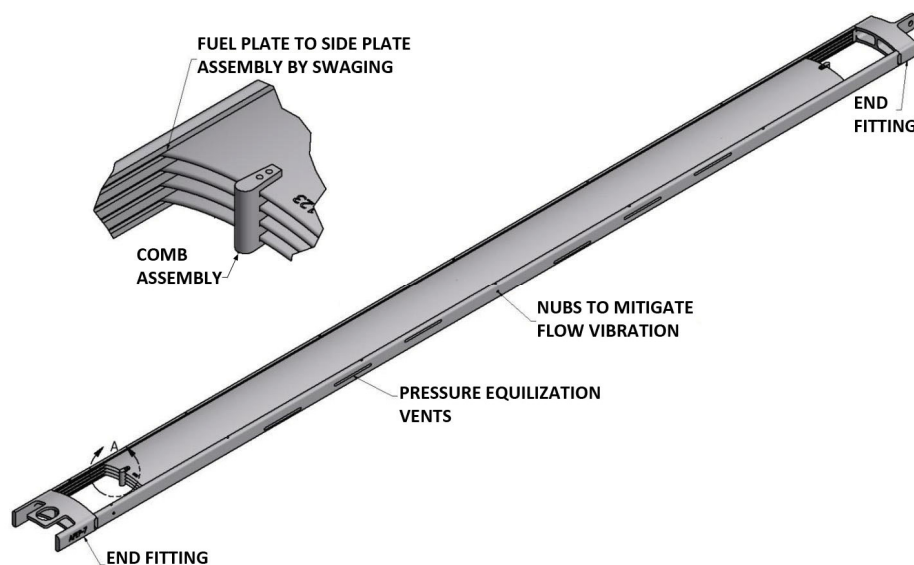

Figure 2: AFIP-7 Fuel Element Assembly

The fuel plates used in the element were fabricated using U-10Mo coupons cast at the Y-12 facility that were co-rolled into fuel foils at the Y-12 facility (1 foil) and Los Alamos National Laboratory (3 foils) and subsequently HIP'ed at the Babcock and Wilcox facility (B&W). The AFIP-7 fuel element assembly was assembled by B&W^[7]. This assembly gave three plate-to-plate coolant channel gaps with a nominal spacing of 0.29 cm at the axial center-plane (i.e. where the comb is located).

The AFIP-7 fuel element was irradiated for two cycles in the ATR Center Flux Trap for a total of 95.6 Effective Full Power Days (EFPD) between June and November of 2011 and achieved local Beginning of Life (BOL) heat flux and an End of Life (EOL) fission density as high as 294 W/cm² and 3.39 E+21 fissions/cc^[8], respectively. The left and right side of all three AFIP-7 fuel element plate-to-plate coolant channel gaps were characterized before irradiation, after the first cycle of irradiation, and following the second cycle of irradiation. These measurements were taken using an ATR in-canal Channel Gap Probe (CGP), which was successfully installed in the ATR canal by the FD team in preparation for the AFIP-7 irradiation, as seen in Figure 3.

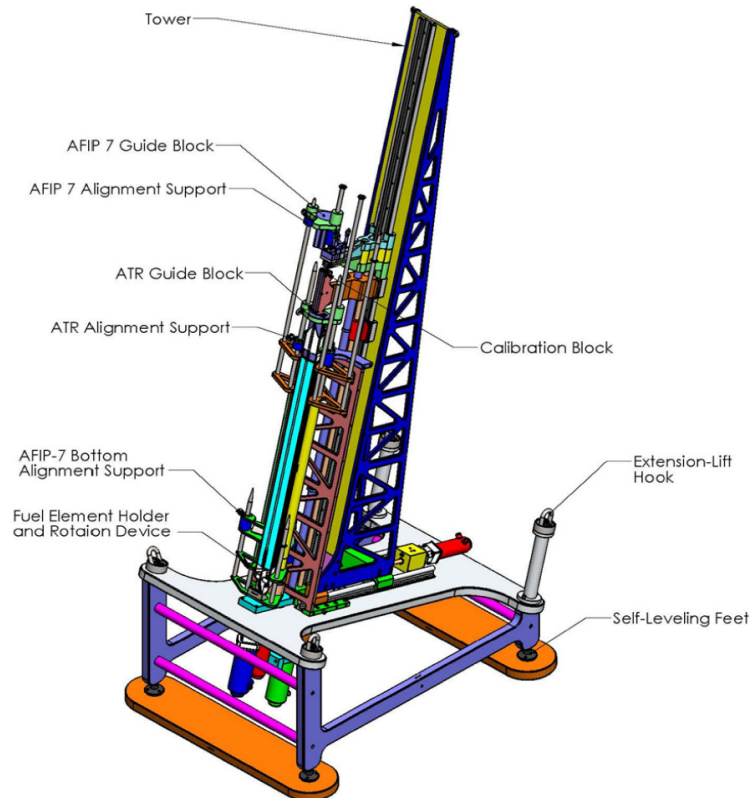

Figure 3: ATR In-canal Channel Gap Probe (image reference [9])

The GCP apparatus inserted a slender metallic blade into the fuel element channels with ultrasonic transducer sensors on the tip. Upon withdrawal the transducers operated based on pulse-echo time-of-flight measurement to measure channel gap distance and was calibrated to gap standards. The apparatus used motor drives to perform the withdrawal and to correlate axial position to each channel gap measurement. The probes were inserted through a precision machined guide block at the top of the element to ensure consistent radial placement within the channel for each measurement. This gave high confidence in the radial placement of the gap measurements near the top of the element. However, since the probe was a slender beam, its radial position could “wander” somewhat with exaggeration of the effect near the bottom of the coolant channel. As a result, the pre- and post-irradiation data which can be most reliably compared are those near the coolant channel top (right side of the traces seen in Figure 4). These show stable behavior of the coolant channel gap with some minor channel closure, likely due to fuel swelling, with no gross plate warping, buckling, or dimensionally unstable behavior. In-canal images of the irradiated AFIP-7 element assembly can be seen in Figure 5.

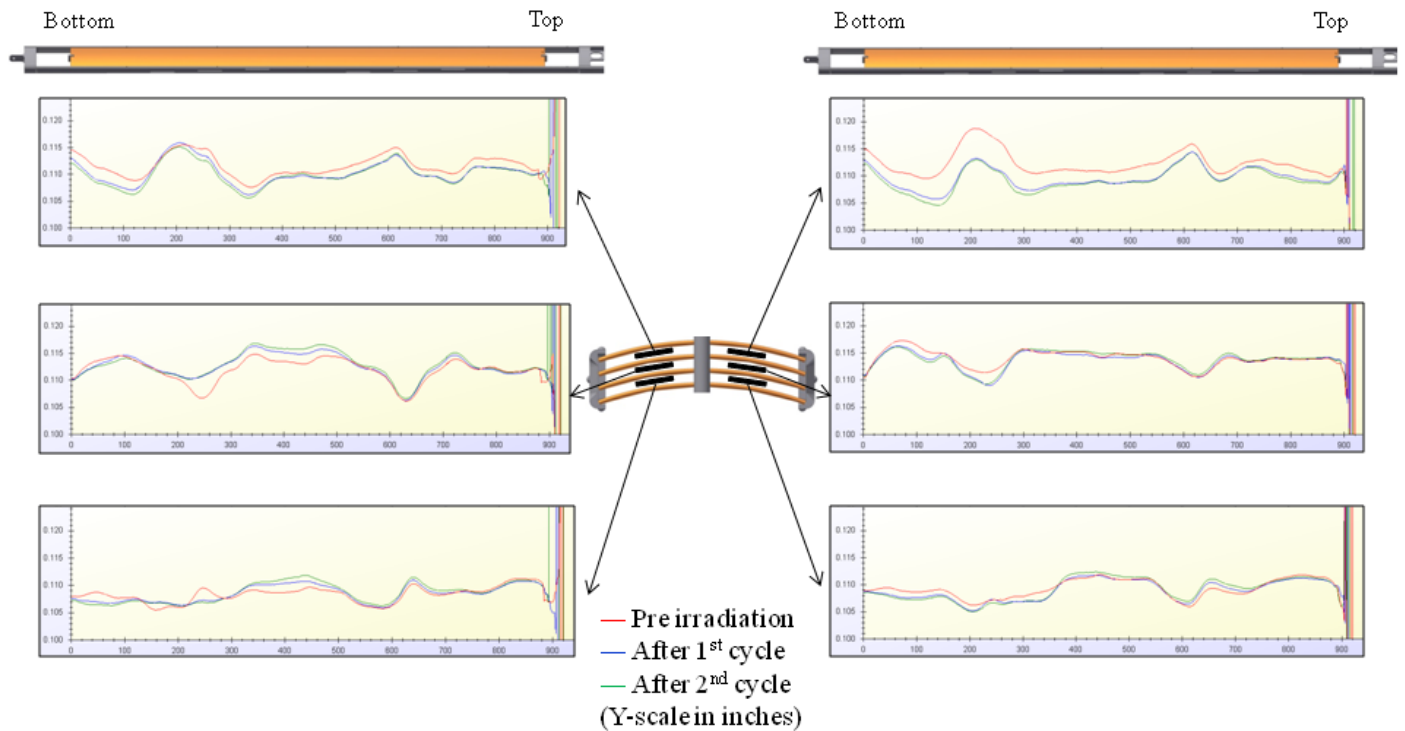

Figure 4: AFIP-7 Channel Gap Probe Data [10]

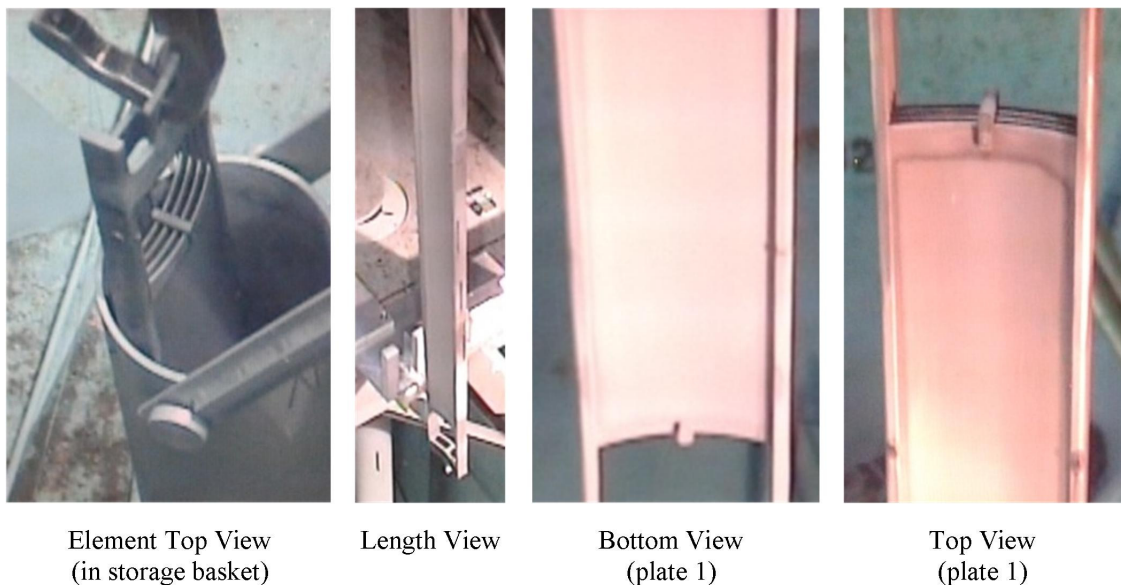

Figure 5: In-canal Images of Irradiated AFIP-7 Element

The AFIP-7 experiment was a hallmark achievement as it was the first test to employ the Base Monolithic Design in an array of multiple plates swaged into frames (i.e. a prototypic fuel element). This demonstrates good promise pertaining to the viability of the Base Monolithic Design for use in HPRR driver fuel elements. The AFIP-7 element assembly is currently awaiting thorough post irradiation examination (PIE) including further characterization of the engineering-scale performance phenomena with detailed fuel plate profilometry and three-dimensional (3D) tomography.

To complement the local channel gap measurements made using the CGP, a complete reconstruction of the fuel element geometry will be developed using neutron tomography. To

develop the reconstruction, the INL NRAD facility (which consists of a TRIGA reactor located in the basement of the HFEF and can image irradiated material) will be used to generate a series of neutron radiographs that are collected as the AFIP-7 experiment is rotated.

In this regard, an aluminum mockup of the AFIP-7 device was provided to Oregon State University (OSU) to investigate image collection and reconstruction procedures. To improve contrast in the images, the element was painted with gadolinium oxide and a small region of the device was imaged. A 3D reconstruction was generated from the leading edges of the plates^[11]. An axial slice extracted from that reconstruction is shown in Figure 6. Dimensional characterization of the reconstructed image is underway and uncertainty is being quantified. Following the completion of these surrogate studies, the irradiated AFIP-7 device will be analyzed using the HFEF NRAD prior to destructive examination.

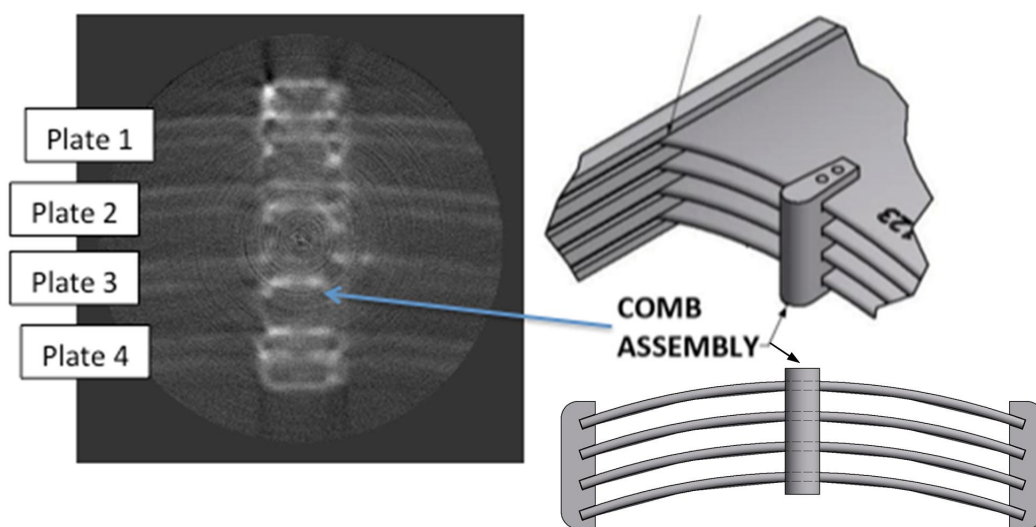

Figure 6: Tomographic reconstruction of the AFIP-7 mockup at OSU (image shows an axial slice of the device taken through the comb assembly and four dummy fuel plates)

3. AFIP-6 MKII

The original AFIP-6 irradiation did not complete irradiation as planned due thermal hydraulic conditions which gave way to severe cladding oxide growth, spallation, and cladding breach^[12]. While the original AFIP-6 experiment revealed much about the Base Monolithic Design's behavior under extreme conditions, it did not fulfill its original purpose of exhibiting an intact irradiated engineering-scale specimen, constrained by swaging, with high fission rates in the fuel meat. To accomplish this purpose the AFIP-6 MKII experiment was irradiated in the center flux trap of the ATR immediately following the irradiation of the AFIP-7 experiment. Like the original AFIP-6 experiment, AFIP-6 MKII employed flat fuel plates, with fuel meat dimensions of 3.49 cm wide \times 57.15 cm long \times 0.033 cm thick, composed of U-10Mo at 40 wt% U-235 enrichment, each swaged within a fuel plate frame assembly as seen in Figure 7. The AFIP-6 MKII irradiation vehicle was designed to house one such fuel plate during the first cycle of irradiation, with a second fuel plate accompanying it during the second cycle. The AFIP-6 MKII irradiation vehicle featured a less restrictive flow path than that of the original^[13].



Figure 7: AFIP-6 MKII Plate Frame Assembly

The first plate was irradiated from December of 2011 to February of 2012 for a total of 56.1 EFPD and achieved a local BOL heat flux and EOL fission density as high as 644 W/cm^2 and $4.89 \text{ E}+21$ fissions/cc^[14], respectively. During in-canal preparation for the second cycle, a small non-fueled component of the first fuel plate frame assembly separated from the overall assembly. This component, referred to as the “bottom plate”, (pictured to the far right side of the frame assembly as seen in Figure 7 above) was thought to have fractured during irradiation due to a flow induced vibration phenomena^[15]. This gave reason to exclude AFIP-6 MKII from the second cycle of irradiation. The AFIP-6 MKII first fuel plate was visually examined in the canal as seen in Figure 8. The plate was also characterized for fuel swelling and meat-clad bond quality via the ATR in-canal ultrasonic scanner^[16]. A through-transmission bond quality scan image can be seen in Figure 9.

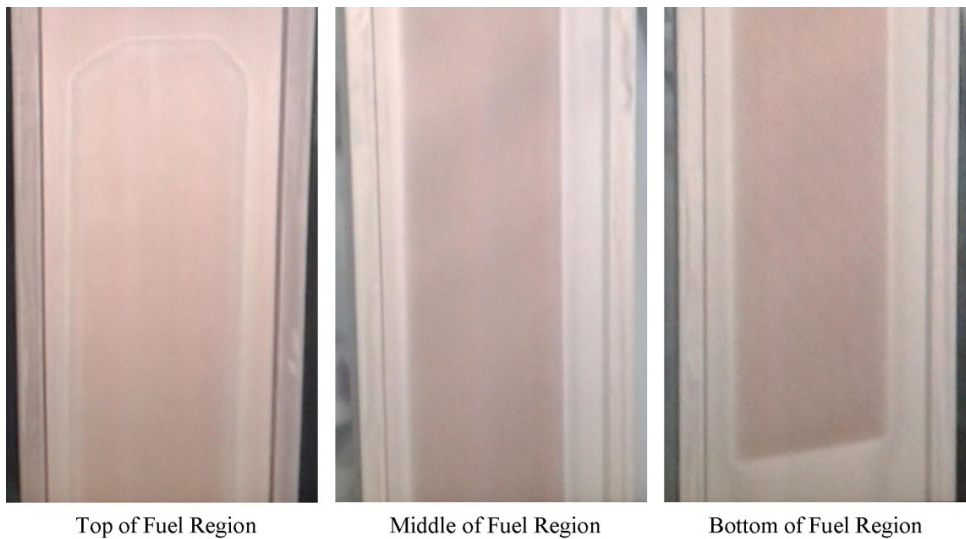

Top of Fuel Region Middle of Fuel Region Bottom of Fuel Region
Figure 8: AFIP-6 MKII In-canal Photography Following Irradiation

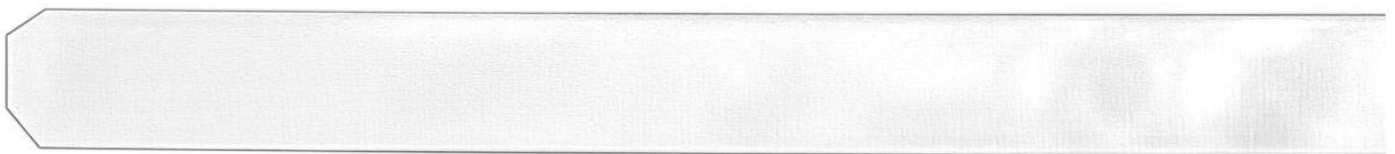

Plate 6II-1 top of fuel region



Plate 6II-1 bottom of fuel region

Figure 9: AFIP-6 MKII Ultrasonic Characterization Following Irradiation

The fuel region of the irradiated AFIP-6 MKII fuel plate exhibited oxidation whose coloration was consistent throughout and showed no evidence of spallation or blistering as seen on the original AFIP-6 fuel plates. The data obtained from the ultrasonic scanner also

demonstrated integrity of the bond with no evidence of large voids, cracks, discontinuities, or unexpected swelling. Detailed PIE for the AFIP-6 MKII fuel plate will be executed in the future, but the examination of this fuel plate in the ATR canal indicate favorable performance of large scale U-Mo monolithic fuel under very high fission rates irradiated to demanding fission densities (peaks greater than 60% LEU equivalent burn-up). Although the experiment was somewhat truncated by a hardware problem, it represents a noteworthy achievement in engineering-scale irradiation testing by demonstrating that the original AFIP-6 cladding breaches were a product of inadequate thermal hydraulic conditions rather than fundamental behaviors of the Base Monolithic Design.

4. Future Engineering-Scale Irradiations

The RERTR Full-size Element (RERTR-FE) and Base Fuel Demonstration (BFD) campaigns were planned for irradiation as ATR driver fuel elements with 11 monolithic fuel plates in the interior positions (plates 5-15) of the existing ATR fuel element design ^{[17][18]} as seen in Figure 10.

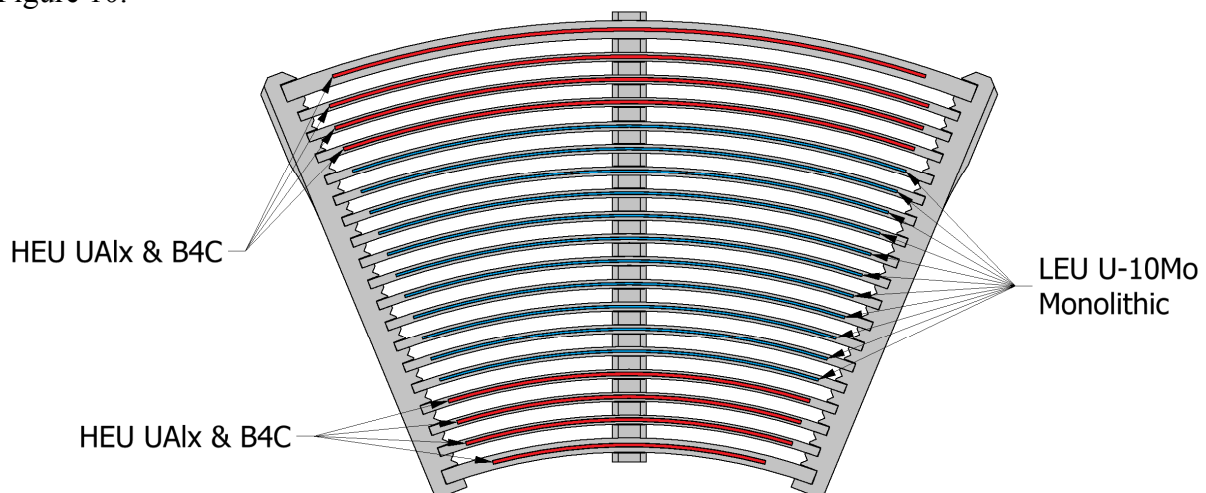

Figure 10: RERTR-BFD Cross Section

These campaigns were intended to augment the results of mini-plate (e.g. RERTR-series) and larger plate (e.g. AFIP-series) irradiation tests and to “demonstrate integrated fuel performance behavior and scale-up of fabrication techniques” in prototype fuel elements ^[17]. While the RERTR-FE design has effectively been completed, final implementation and irradiation have been delayed due to difficulties in the fabrication effort. BFD design work was recently undertaken and has shown that the BFD design would benefit from including fuel in plate number 19, rather than a dummy plate as in the RERTR-FE design, in order to influence the plate-to-plate power profile ^{[18][19]} in such a way as to improve the thermal hydraulic margins of the irradiation. While both these campaigns have been delayed, their purposes will eventually be accomplished either in future element test irradiations or through integration into the ATR Lead-Test Assembly (LTA) effort.

While the much of the fuel performance data needed for the safety analyses of to-be-converted HPRR’s will be obtained through testing of smaller scientific-scale specimens, demonstration of full-scale application-specific fuel assemblies will be one of the key deliverables in the course of regulatory approval for HPRR conversions. For reactors whose operational bases allow them to test their own LEU driver fuel element designs, such as the ATR, this is likely to be accomplished largely through the use of LTA’s in a few driver positions followed by strategic phasing-in of LEU fuel elements until an entirely-LEU fuel

cycle is achieved. For other reactors whose regulatory bases will not allow for LTA testing in the LTA manner, such as the Massachusetts Institutes of Technology Reactor (MITR), University of Missouri Research Reactor (MURR), and National Bureau of Standard Reactor (NBSR), or for reactor’s whose design will not allow mixing of LEU and HEU fuel assemblies in “transition cores”, such as the High Flux Isotope Reactor (HFIR), the task of demonstrating the LEU “end use application” in a “design environment” [20] will be accomplished via Design Demonstration Experiments (DDE’s).

The core concept driving the DDE campaigns is to irradiate fuel assemblies, which represent the LEU design of a given end-user’s reactor, at the engineering-scale, with exacting design environment irradiation conditions. DDE irradiations differ from the LTA methodology in performing the irradiation in a reactor other than the end-user’s reactor. It is acknowledged that simulating a given set of conditions within a different reactor can produce technical challenges, but the DDE irradiations are necessary to give confidence in the reactor specific LEU designs. This will serve to facilitate regulatory approval of conversion as well as to mitigate operational risks to the users of these HPRR’s, many of whom have a well-established users base with their own schedules and objectives.

The FD team has recently produced viable conceptual designs for DDE irradiations pertaining to the MITR, MURR, and NBSR LEU fuel assembly designs and projected design environments. While resource complications have given way to a temporary hiatus of this design work, analysis and engineering evaluations have shown promising results in achieving distinct design objectives and simulating unique irradiation conditions. These design efforts, along with efforts regarding a DDE irradiation purposed to represent the HFIR, will be undertaken at some point in the future.

The DDE-MITR experiment has been designed for irradiation in the reflector-positioned “Medium-I” facilities of the ATR. This will allow for three full-size MITR LEU fuel plates, complete with the unique plate surface heat transfer “fins”, assembled and swaged in a mini-element, to be irradiated with fission rate and burn-up parameters similar to those of the projected MITR LEU core. Features such as local hafnium filters in the irradiation vehicle and strategic placement within the Medium-I facility have also shown viability in simulating the projected MITR LEU fuel plate fission gradients. Currently two such assemblies are planned to give a total of six LEU MITR fuel plates. These are planned for characterization in the ATR in-canal CGP [21]. This concept is shown in Figure 11.

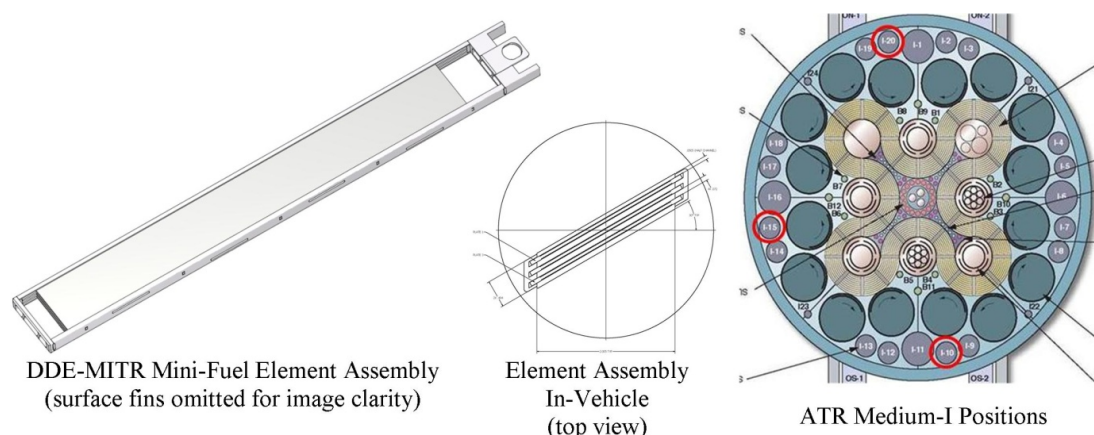

Figure 11: DDE-MITR Conceptual Layout

The DDE-MURR experiment has been designed for irradiation in one of the 200mm “H” positions in the Belgium Reactor 2 (BR2). This will enable an entire MURR LEU fuel element to be irradiated. This is projected to achieve fission rates and burn-ups which represent the MURR LEU design [22]. In order to produce the needed engineering-scale fuel performance data, the campaign will also require new apparatuses to be installed at the BR2 and associated hot cell facilities including a BR2 CGP and other PIE equipment [23]. This concept is shown in Figure 12.

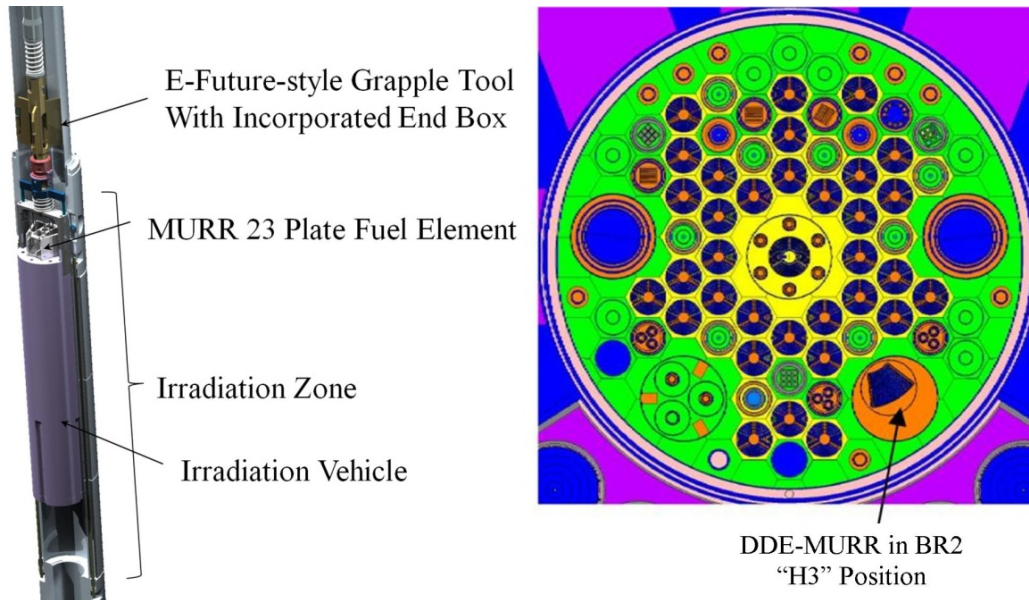

Figure 12: DDE-MURR Conceptual Layout

The DDE-NBSR experiment has been designed for irradiation in the ATR center flux trap. This allows for three rows of three full-size NBSR LEU fuel plates (total of nine) with the ability to achieve fission rates and high burn-ups (nearly 100% LEU burn-up) as currently projected for the NBSR LEU core. Additionally, the irradiation vehicle makes use of hafnium rods, with strategic proximity to the fuel plates, to increase fission rate gradient edge-peaks as a simulation of the NBSR D₂O moderated environment. Like DDE-MITR, this experiment will be characterized in the ATR in-canal CGP [24]. This concept is shown in Figure 13.

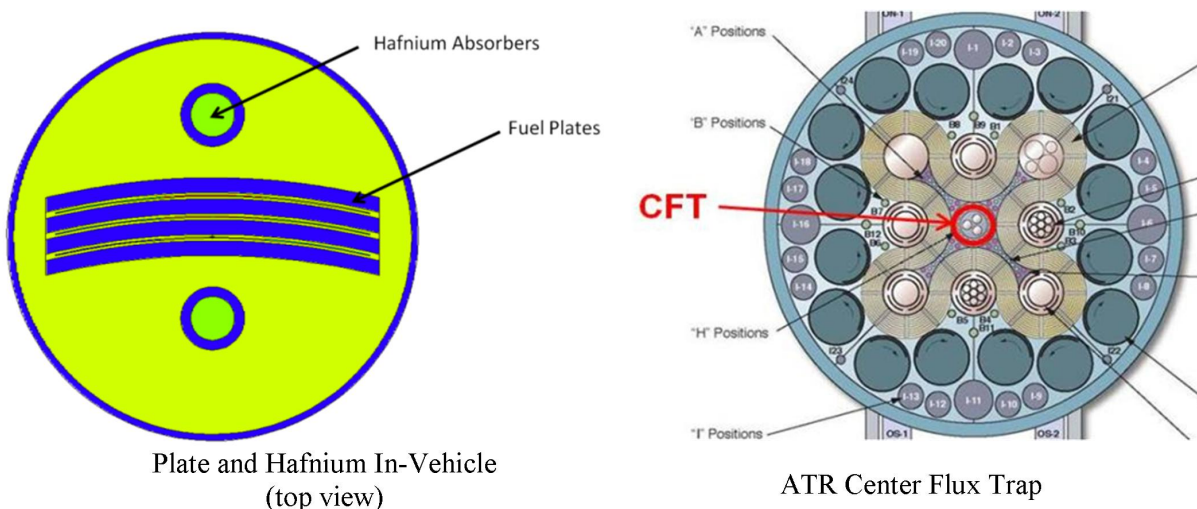

Figure 13: DDE-NBSR Conceptual Layout

5. References

- [1] D.M. Wachs, "RERTR Fuel Development and Qualification Plan", rev 5, 07/05/2011, INL external report INL/EXT-05-01017.
- [2] N.E. Woolstenhulme, D.M. Wachs, and M.K. Meyer, "Design and Testing of Prototypic Elements Containing Monolithic Fuel", Proceeding of the RERTR-2011 conference, Oct 23-27, Santiago, Chile.
- [3] A.B. Robinson et al., "Irradiation Performance of U-Mo Alloy Based 'Monolithic' Plate-Type Fuel – Design Selection", INL report INL/EXT-09-16807, Aug. 2009.
- [4] PLN-3447, "Experiment Control for the AFIP-7 Fuel Irradiation in the ATR," Rev. 1, January 2011.
- [5] INL drawing 602648, "AFIP-7 Experimental Element Fuel Plate Assembly", Rev 0, 11/18/2010.
- [6] INL drawing 405400, "ATR Mark VII Fuel Element Assembly", Rev 19, 10/29/74.
- [7] G. Moore, "AFIP-7 Fabrication Summary Report," INL/LTD-11-26917, September 2012.
- [8] D.M. Perez et al., "AFIP-7 Irradiation Summary Report", INL/EXT-12-25915, September 2012.
- [9] INL document TEV-1280, "Technical Evaluations for the ATR Channel Gap Probe", August 2011.
- [10] INL document TEV-1169, "AFIP-7 Ultrasonic Channel Gap Test Results", September 2012.
- [11] S. Reese, Neutron Tomography Program: Monthly Report for August 2012, Oregon State University, INL Contract 00044868-00025
- [12] D. Wachs et al., "AFIP-6 Breach Assessment Report, INL/INT-11-21110, February 2011.
- [13] PLN-3699, "Experiment Control for the AFIP-6 MKII Fuel Irradiation in the ATR," Rev. 2, August 2011.
- [14] D.M. Perez et al., "AFIP-6 Mark II Irradiation Summary Report", INL/EXT-12-26305, September 2012.
- [15] N.E. Woolstenhulme, "AFIP-6 MKII First Cycle Report", INL/EXT-12-25170, March 2012.
- [16] INL document TEV-1528, "AFIP-6 MKII Plates 1 and 2 Ultrasonic Debond, Min-Clad, and Post-Irradiation Plate Thickness Test Results", September 2012.
- [17] INL document PLN-2946, "Demonstration Control Plan for the RERTR Full-Size Element", rev 1, March 2011.
- [18] INL Internal Report INL/INT-12-27330, "Status Report of the Base Fuel Demonstration Hybrid Element Design", September 2012.
- [19] INL Document ECAR-2059, "Conceptual Design Analysis for the Base Fuel Demonstration Element in the Advanced Test Reactor", rev 0, September 2012.
- [20] "Applying Quality Assurance Requirements to Research and Development Activities", rev 3, 8/12/2010, INL Document LWP-13016.
- [21] N.E. Woolstenhulme et al., "DDE-MITR Status Report of Conceptual Design Activities", INL/EXT-12-27077 September 2012.
- [22] V. Kuzminov to S. Van Dyck and E. Koonen, "DDE-MURR assembly: Provisional heat fluxes in channels H5, H4, H3", technical note 06/18/2012.
- [23] N.E. Woolstenhulme et al., "DDE-MURR Status Report of Conceptual Design Activities", INL/EXT-12-27078 September 2012.
- [24] N.E. Woolstenhulme et al., "DDE-NBSR Status Report of Conceptual Design Activities", INL/EXT-12-27079 September 2012.