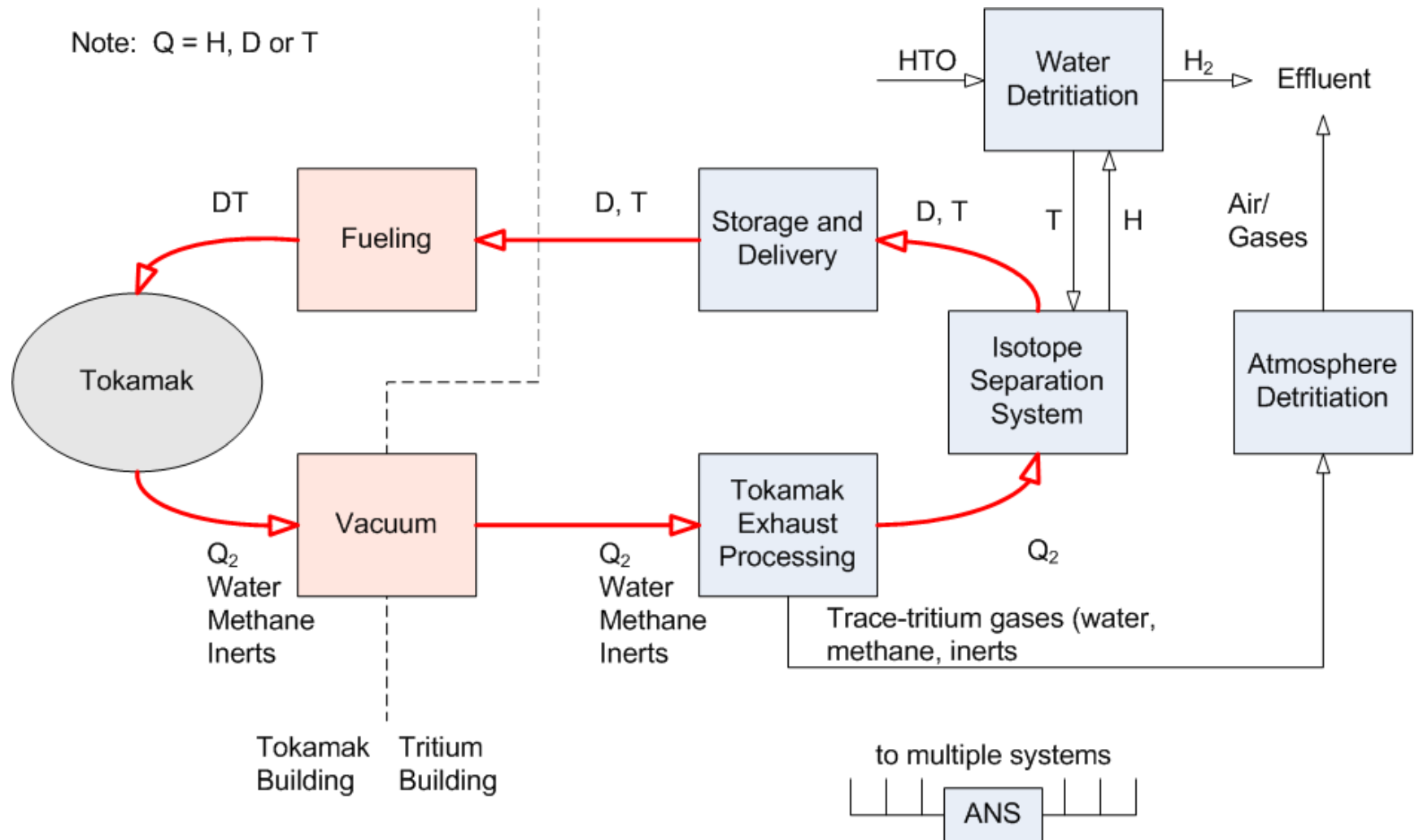

ITER Fuel Cycle Paths To DT

Scott Willms (US) and Manfred Glugla (IO)

ITER Fuel Cycle Integrated Product Team

February 17, 2010

Simplified view of ITER Fuel Cycle



“Scenario 1” Impacts

- All ITER Fuel Cycle systems were to be fully ready at “first plasma” (2018). This schedule was revised to the “Scenario 1” sequence with “first plasma” in 2019, but full DT beginning in 2026
 - This results in four (rather than one) key endpoints for the ITER Fuel Cycle
- A Fuel Cycle Integrated Project Team (FC-IPT) Task Force was established in July 2009 to
 - Analyze the Fuel Cycle requirements in HH, DD, Trace T and DT
 - Consider technology solutions to meet requirements
 - Consider non-tritium and tritium compatible solutions
 - Consider staging/scheduling to meet requirements
 - Develop strategies for Fuel Cycle systems testing and commissioning
- Task Force led by Scott Willms (LANL (US), FC IPT deputy leader)

Fuel Cycle Outline (functional) Drawings

- Functional drawings for HH, DD, Trace T and DT have been drafted
 - Drawings include all Fuel Cycle packages
 - Highest-level process drivers identified
 - Highest-level process interfaces defined
 - Lines are labeled with
 - Major fluid composition (gases)
 - Hydrogen isotope content
 - Stream properties or uses
 - More detail given in Process Flow Diagrams
- Technology options (value engineering) for HH, DD, Trace T and DT have been identified

Drawing Features

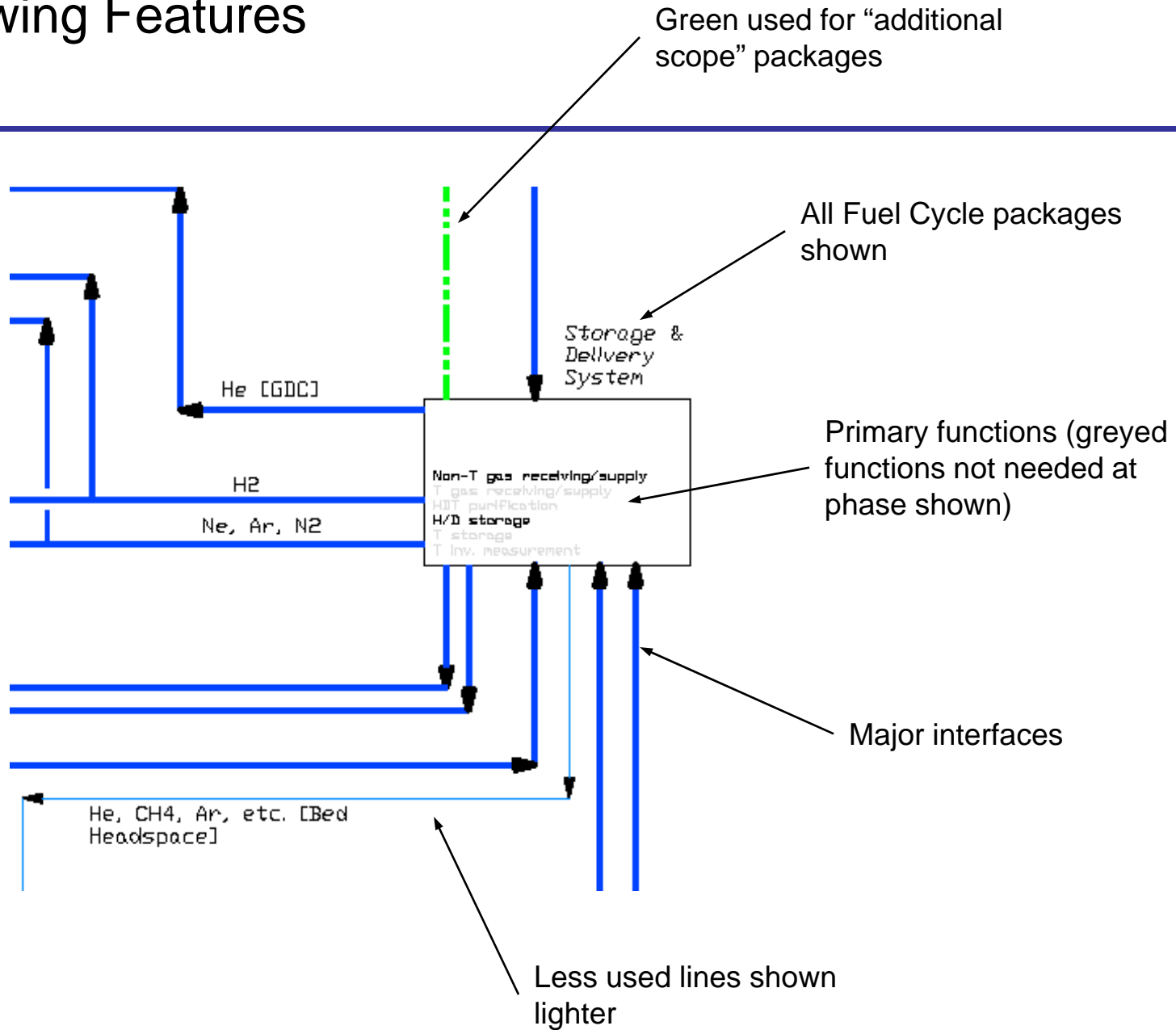

Drawing features - line descriptions

Explanatory note ()

Mode associated with primary constituent []

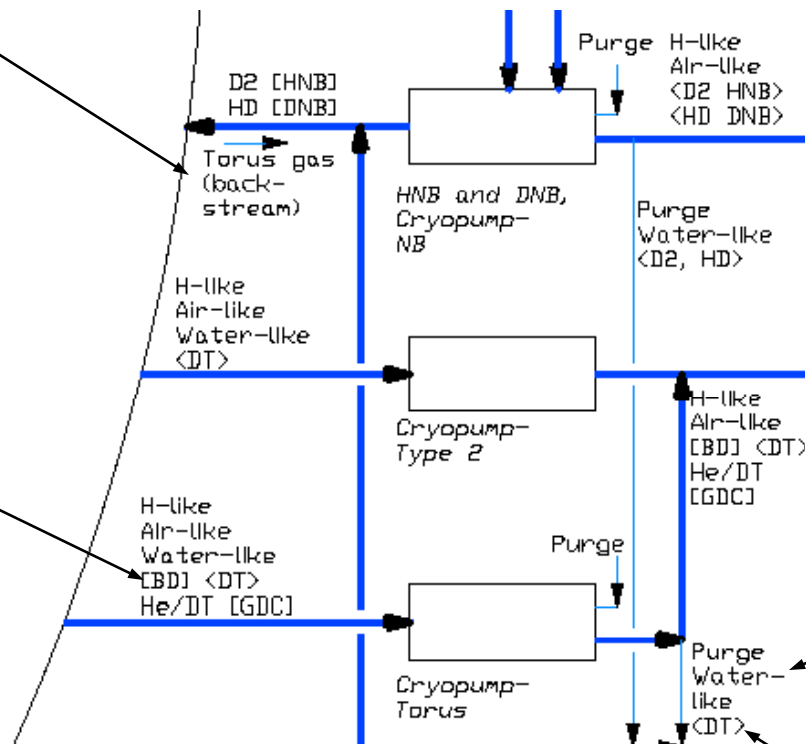

Line primary constituent

Primary hydrogenic species in primary component < >

HH

- HVAC
- Some systems already in final configuration (e.g. cryopumps)
- Hydrogen recycle?

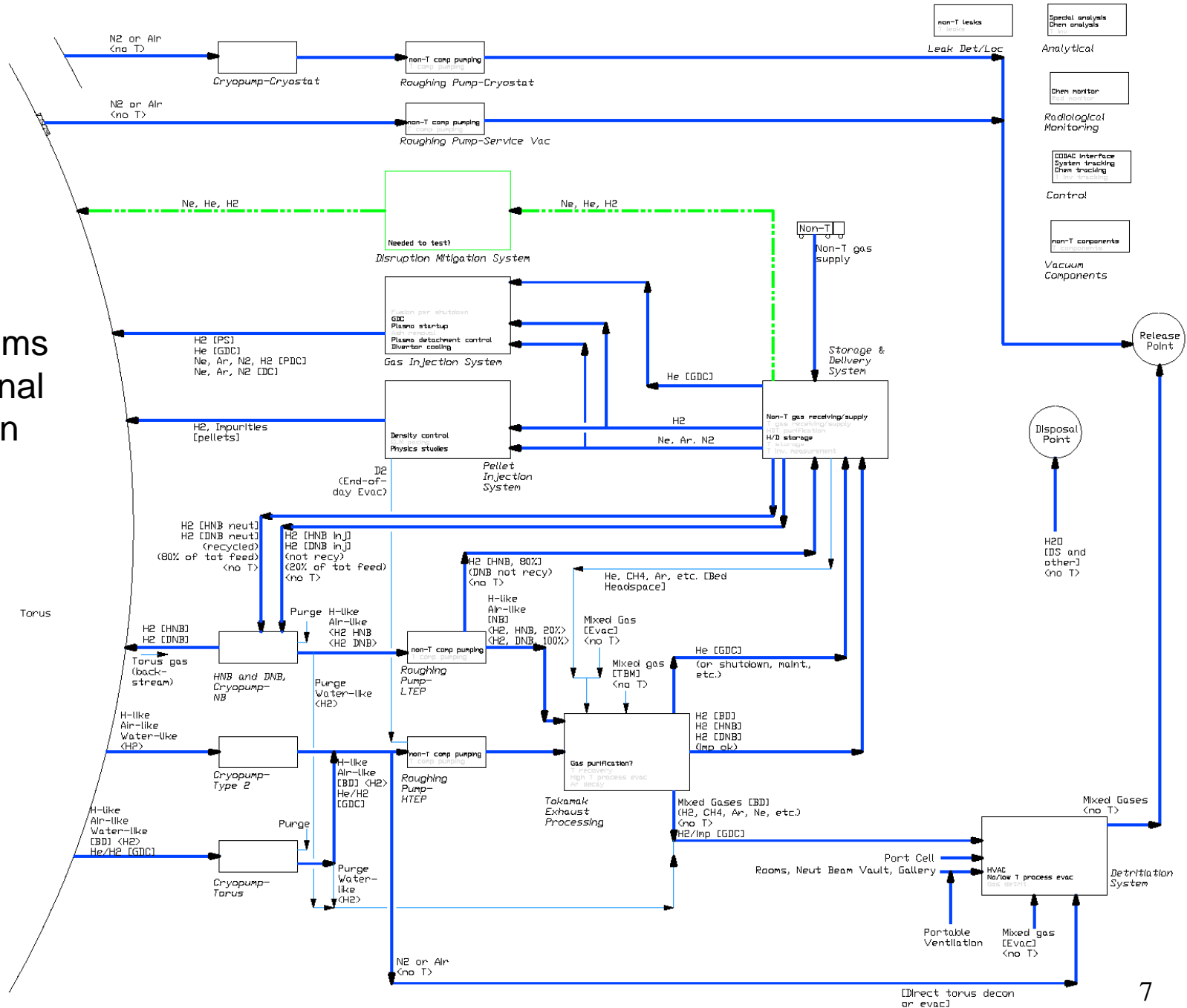

DD

- Confinement, Radiological Monitoring & detritiation
- Tritium removal from D₂

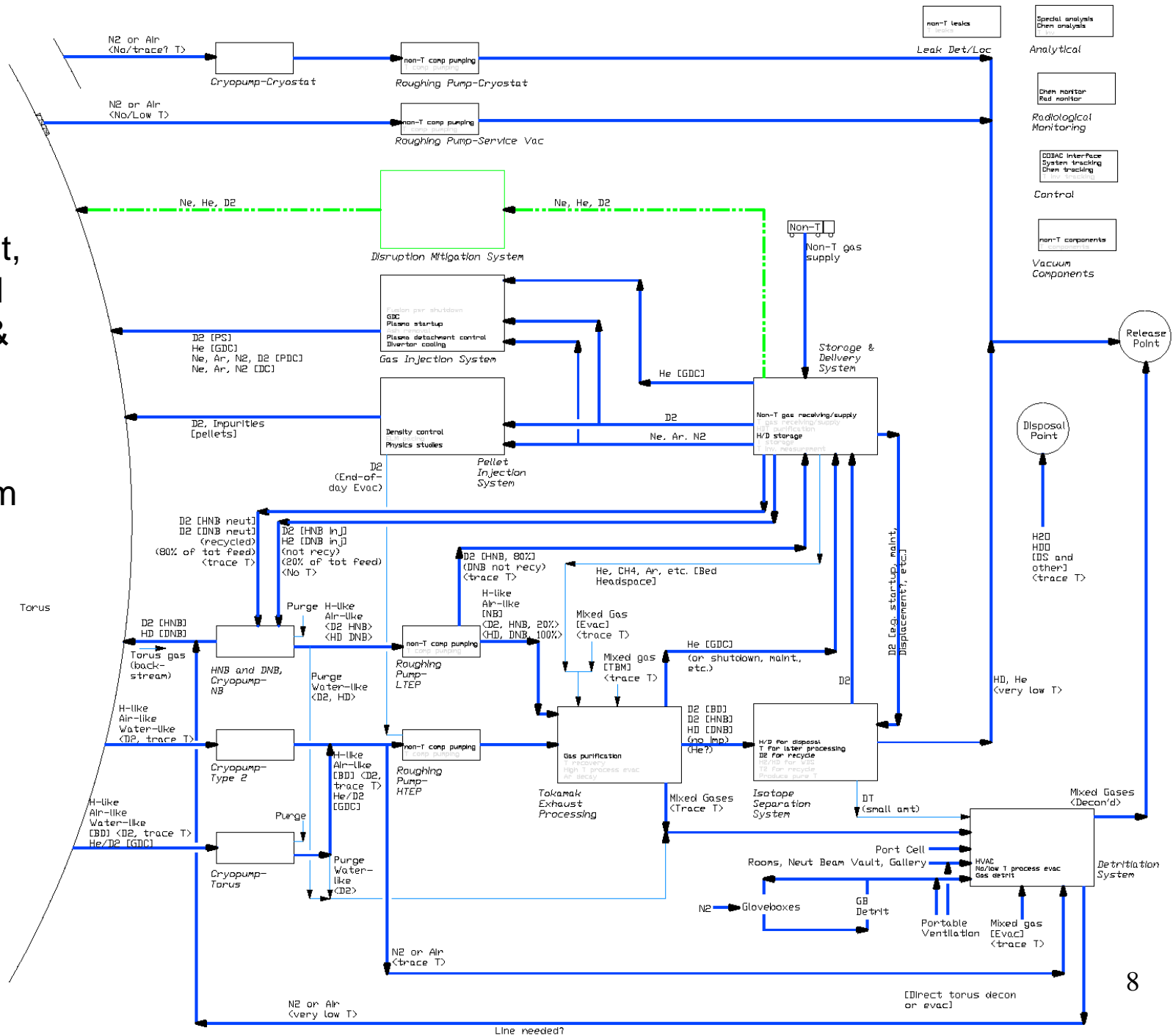

Trace T

- External T supply
- T inventory measurements

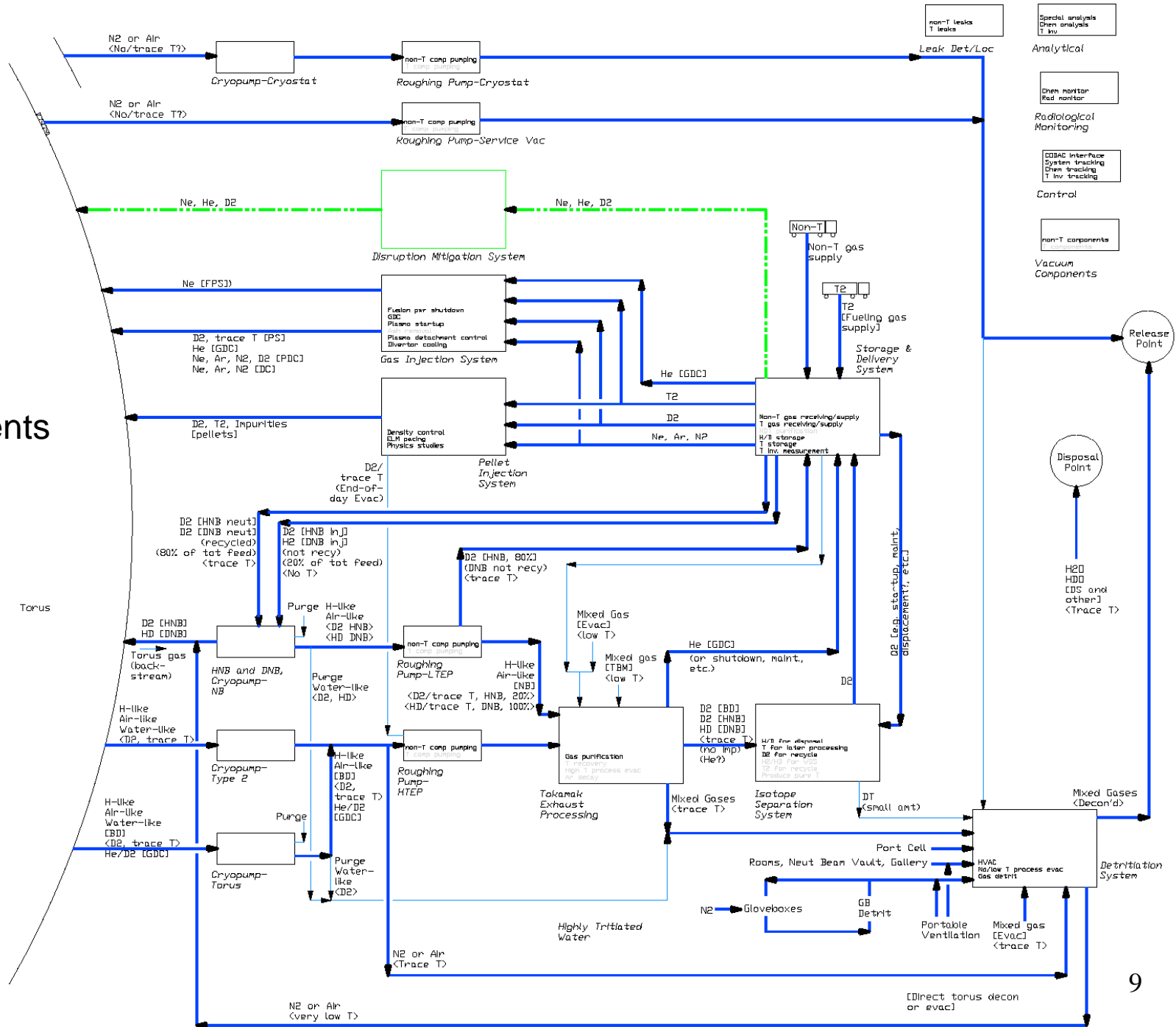

DT

- Full tritium capability
- Major increase in tritium processing rate and inventory

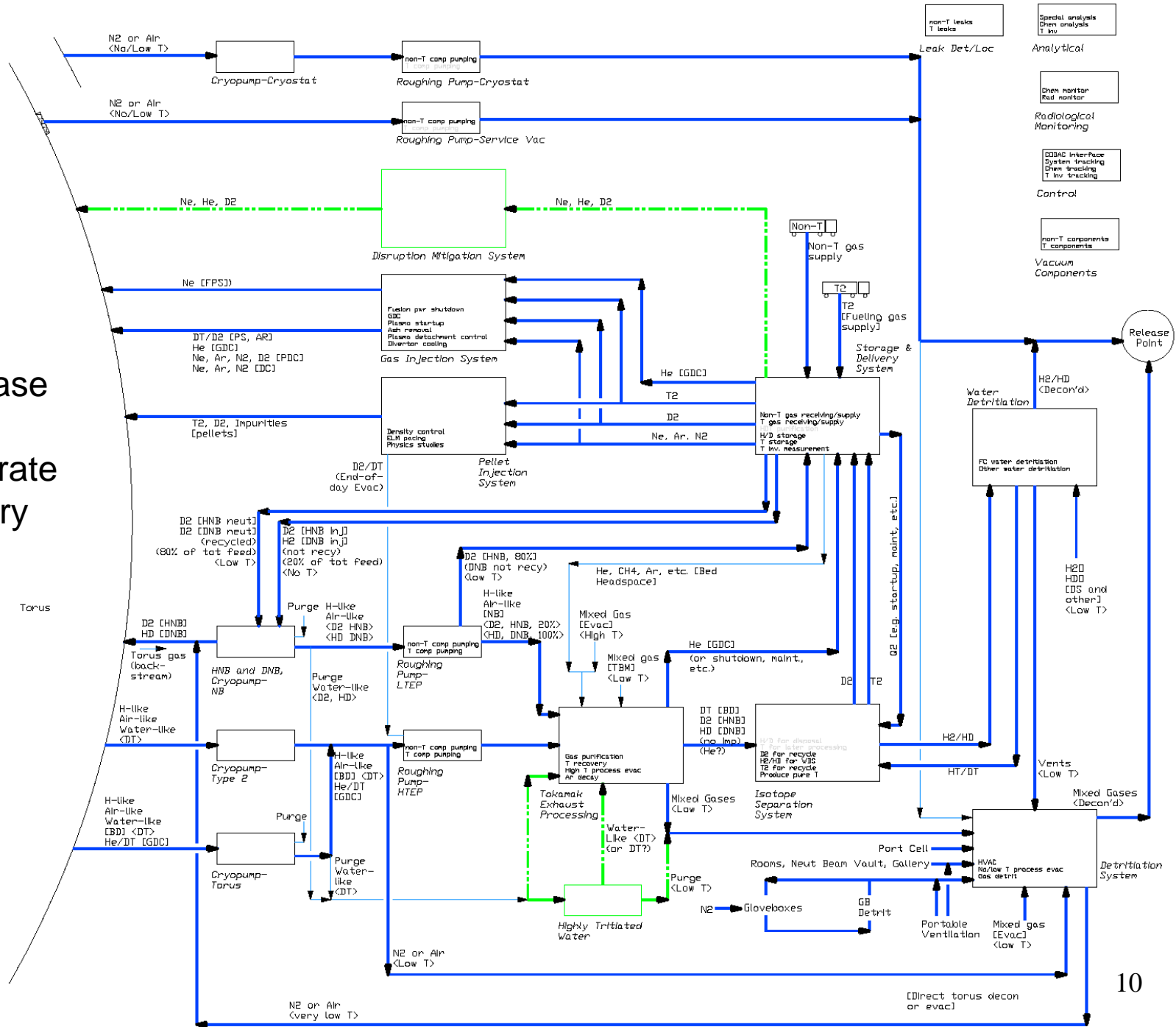

Key considerations on pathways to DT

- Fuel Cycle systems available in time to meet ITER requirements
- Increasing nuclear function
- Consider non-tritium/tritium compatibility needs (value engineering)
- No tritium operation prior to “pre-nuclear shutdown”
- Staged installation facilitates testing, integration, commissioning, training and debugging

FC “Scenario 1” Outline Schedule Development

- Start with ITER-wide schedule elements (e.g. first plasma and pre-nuclear shutdown)
- Include a “finalization period” prior to each ITER phase
 - Period for integration, debugging, commissioning and training
- Estimate the time needed to define, design, construct and install each system
 - Durations in this presentation are very rough estimates
 - Assumed that tasks start as late as reasonably practical
- At present, this is very much a “work in progress”

Fuel Cycle Scenario 1 Outline Schedule – Overall ITER schedule

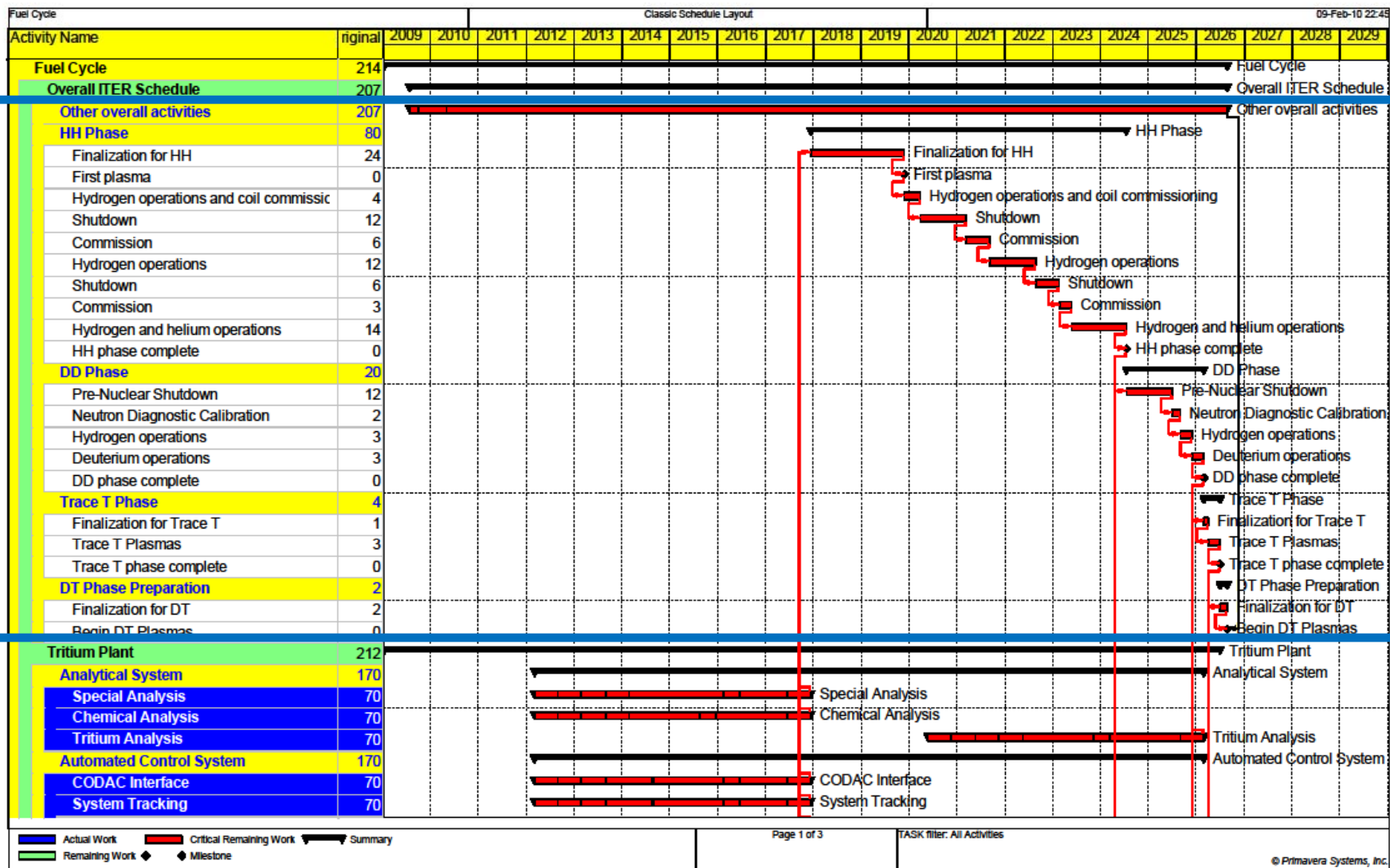

Fuel Cycle Scenario 1 Outline Schedule – Generic detail for each fuel cycle element

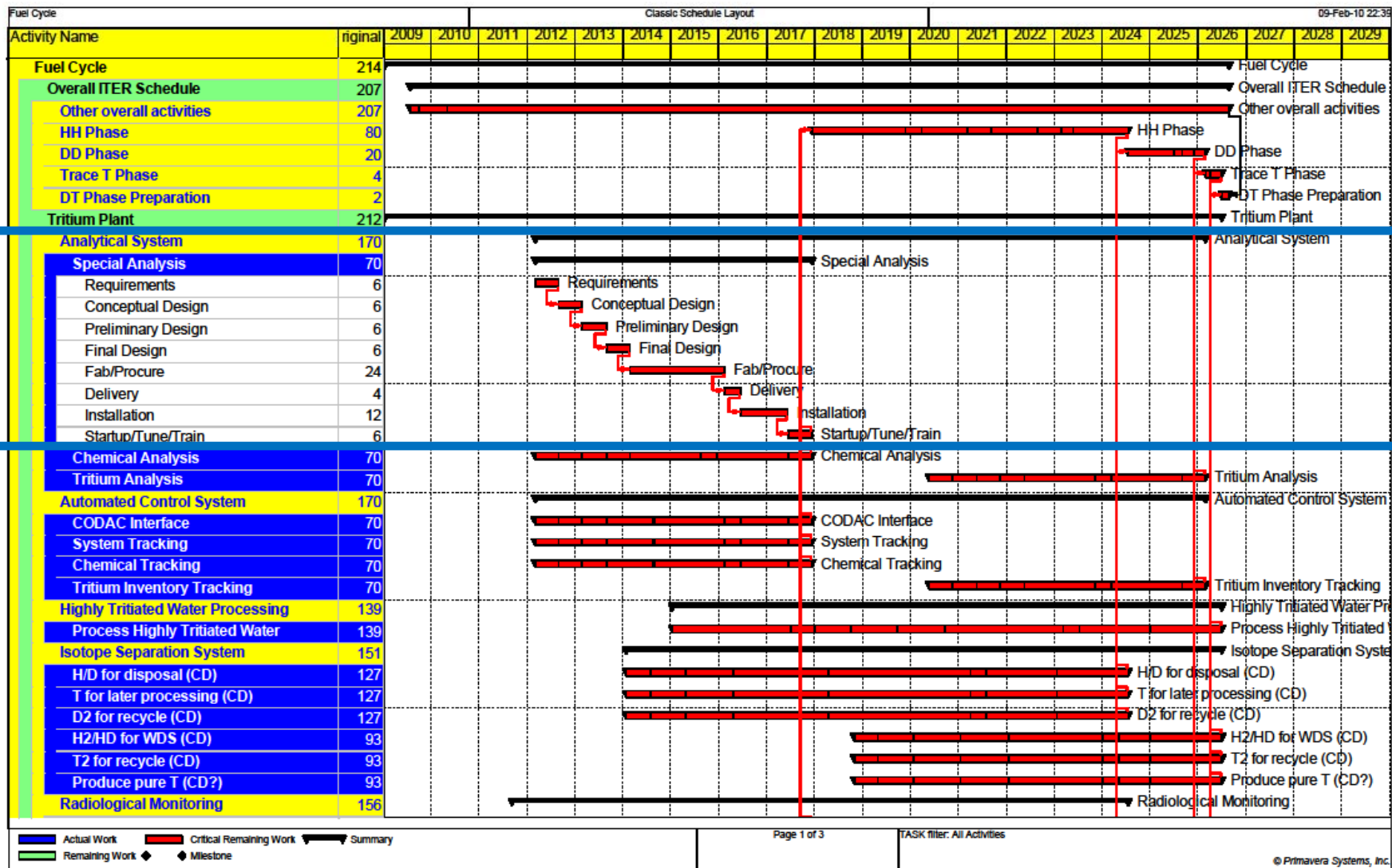

Fuel Cycle Scenario 1 Outline Schedule – Fuel cycle overview

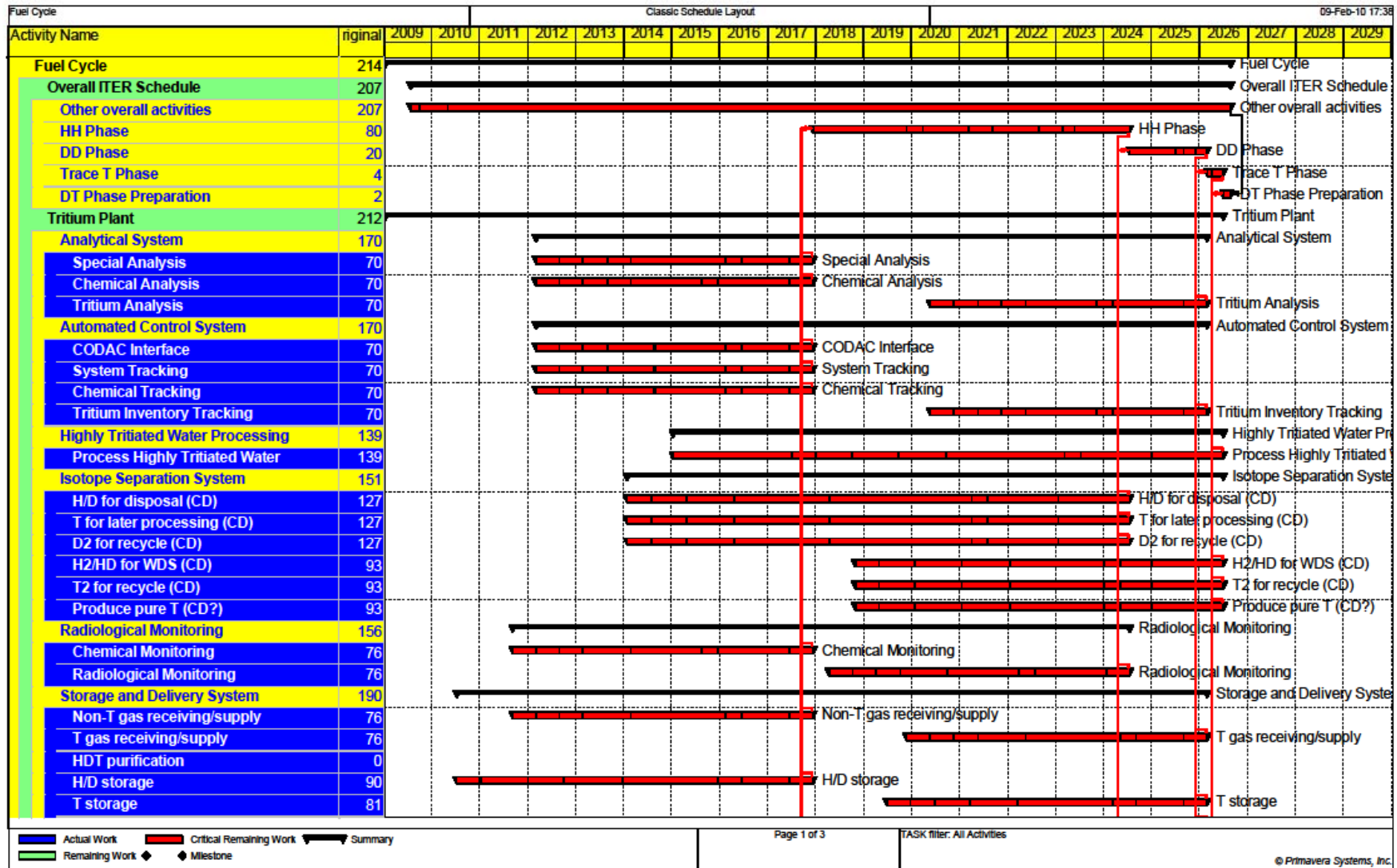

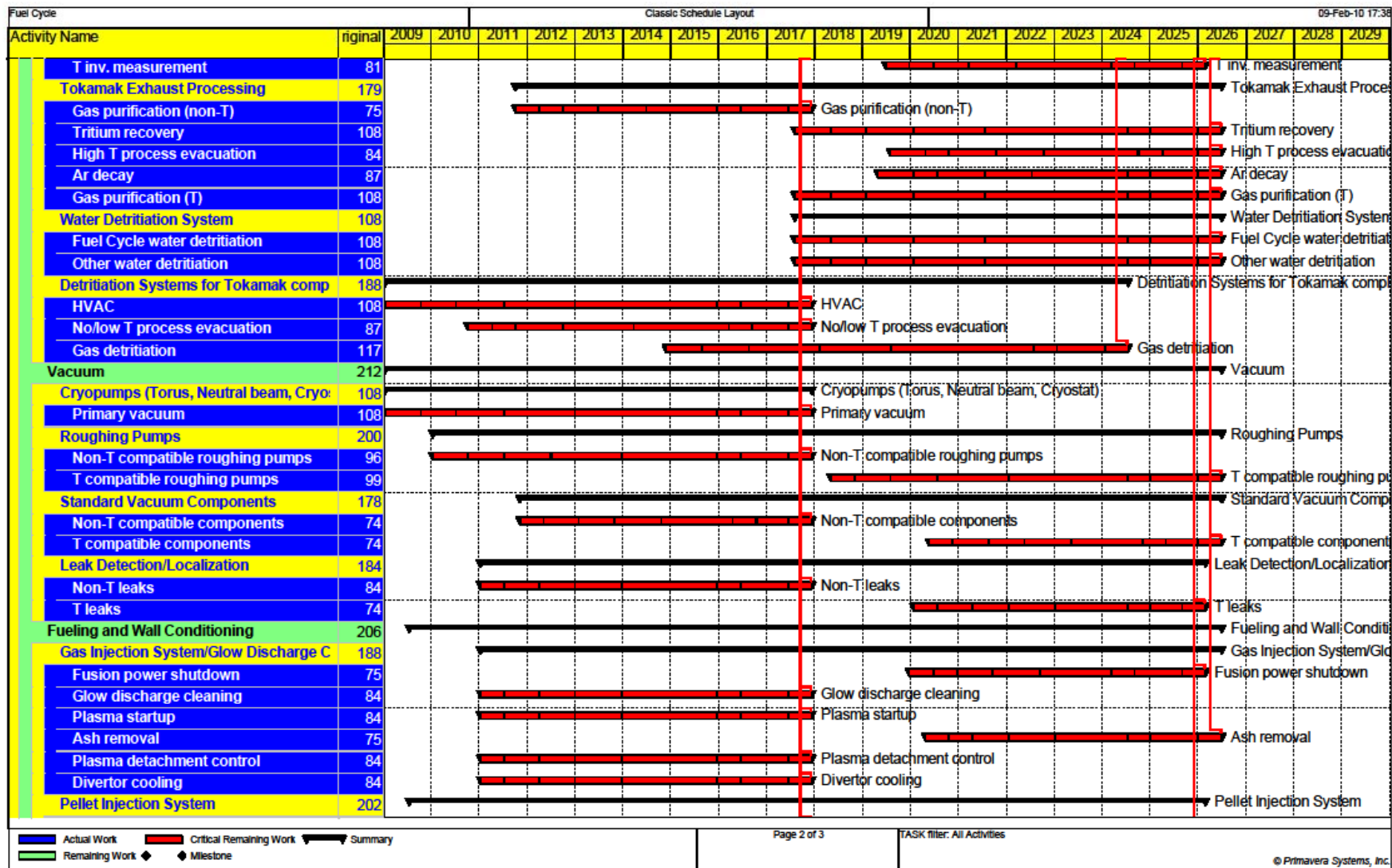

Activity Name	Original	2009	2010	2011	2012	2013	2014	2015	2016	2017	2018	2019	2020	2021	2022	2023	2024	2025	2026	2027	2028	2029
Density control	102																					
ELM pacing	81																					
Physics studies	102																					
Disruption Mitigation System	84																					
Disruption mitigation	84																					

█ Actual Work
 █ Critical Remaining Work
 ▼ Summary
█ Remaining Work
 ◆ Milestone

Summary

- Scenario 1 has significant impacts on the overall ITER schedule
- The impacts of this on the ITER Fuel Cycle are being evaluated
 - Draft drawings, spreadsheet and schedules have established a high-level framework for evaluating impacts
 - These documents will form the basis for upcoming meetings and discussions. Results will be used to revise these documents.
 - Ultimately this exercise will help guide revisions to current ITER documents