

TECHNICAL MANUAL

**OPERATION AND MAINTENANCE  
SMALL HEATING SYSTEMS**

***REPRODUCTION AUTHORIZATION/RESTRICTIONS***

***This manual has been prepared by or for the Government and is public property and not subject to copyright.***

***Reprints or republications of this manual should include a credit substantially as follows: "Department of the Army Technical Manual, TM 5-642, Operating and Maintenance, Small Heating Systems."***

## OPERATION AND MAINTENANCE SMALL HEATING SYSTEMS

### Table of Contents

	Paragraph	Page
CHAPTER 1. INTRODUCTION		
Purpose and scope . . . . .	1-1	1-1
References . . . . .	1-2	1-1
Abbreviations and terms . . . . .	1-3	1-1
Organization and responsibility . . . . .	1-4	1-1
Systems overview . . . . .	1-5	1-1
Energy conservation policy . . . . .	1-6	1-2
Chapter 2. FUELS		
Section I. Coal		
General . . . . .	2-1	2-1
Section II. Fuel Oils		
General . . . . .	2-2	2-1
Classification of fuel oils . . . . .	2-3	2-1
Oil tanks . . . . .	2-4	2-2
Section III. Natural Gas		
General . . . . .	2-5	2-3
Gas handling and storage . . . . .	2-6	2-3
Gas handling precautions . . . . .	2-7	2-4
Section IV. Liquefied Petroleum Gas		
General . . . . .	2-8	2-4
Characteristics . . . . .	2-9	2-4
Specifications . . . . .	2-10	2-4
LPG storage and handling . . . . .	2-11	2-4
CHAPTER 3. FUEL BURNING EQUIPMENT		
Section I. Coal Stokers		
General . . . . .	3-1	3-1
Single-retort underfeed stokers . . . . .	3-2	3-1
Operation . . . . .	3-3	3-1
Inspection and maintenance procedures . . . . .	3-4	3-2
Troubleshooting underfeed stokers . . . . .	3-5	3-2
Section II. Hand-Fired Coal Burners		
General . . . . .	3-6	3-2
Furnace types . . . . .	3-7	3-2
Operation . . . . .	3-8	3-4
Section III. Oil Burners		
General . . . . .	3-9	3-5
Burner descriptions . . . . .	3-10	3-5
Ignition procedures . . . . .	3-11	3-9
Oil burner operation . . . . .	3-12	3-10
Inspection and maintenance of oil burners . . . . .	3-13	3-10
Fuel oil piping . . . . .	3-14	3-13
Section IV. Gas Burners		
General . . . . .	3-15	3-16
Burner types with descriptions . . . . .	3-16	3-16
Operation procedures . . . . .	3-17	3-16
Starting procedures . . . . .	3-18	3-18
Inspection and maintenance . . . . .	3-19	3-19

---

\*This manual supercedes TM 5-642, Jun 46 and rescinds TM 5-644, Jul 46 and TM 5-646, Jun. 46

	Paragraph	Page
Section V. Dual Fuel (Oil/Gas) Burners		
General . . . . .	3-20	3-21
Operation . . . . .	3-21	3-21
Inspection and maintenance . . . . .	3-22	3-21
Section VI. Energy Conservation		
Adjustments to excess air . . . . .	3-23	3-21
CHAPTER 4. STEAM HEATING SYSTEMS		
General . . . . .	4-1	4-1
Section I. Description of Systems		
General . . . . .	4-2	4-1
Gravity one-pipe air vent system . . . . .	4-3	4-1
Two-pipe vapor system with return trap . . . . .	4-4	4-4
Two-pipe vapor system with condensate pump . . . . .	4-5	4-5
Two-pipe vacuum system with vacuum pump . . . . .	4-6	4-6
Section II. Boiler Types		
Cast iron boilers . . . . .	4-7	4-8
Steel boilers . . . . .	4-8	4-11
Fire-tube boilers . . . . .	4-9	4-11
Water-tube boilers . . . . .	4-10	4-13
Initial operation and cleaning . . . . .	4-11	4-14
Special maintenance requirements . . . . .	4-12	4-14
Section III. Boiler Headers, Valves and Piping Connections		
Installation . . . . .	4-13	4-15
Maintenance . . . . .	4-14	4-15
Section IV. Boiler Return Traps		
Installation . . . . .	4-15	4-15
Initial operation . . . . .	4-16	4-18
Maintenance . . . . .	4-17	4-18
Typical operating difficulties . . . . .	4-18	4-18
Section V. Condensate Pumps		
General . . . . .	4-19	4-18
Installation . . . . .	4-20	4-18
Operation . . . . .	4-21	4-19
Maintenance . . . . .	4-22	4-20
Typical operating difficulties . . . . .	4-23	4-20
Steam pressure pumping systems . . . . .	4-24	4-21
Section VI. Vacuum Pumps		
General . . . . .	4-25	4-22
Installation . . . . .	4-26	4-23
Controls . . . . .	4-27	4-24
Initial operation and cleaning . . . . .	4-28	4-25
Maintenance . . . . .	4-29	4-26
Typical operating difficulties . . . . .	4-30	4-26
Section VII. Water Level Regulators and Controls		
General . . . . .	4-31	4-28
Installation . . . . .	4-32	4-28
Initial operation and servicing . . . . .	4-33	4-29
Operation and maintenance . . . . .	4-34	4-29
Typical operating difficulties . . . . .	4-35	4-29
Section VIII. Boiler Trimmings, Gauges, Pop Safety Valves		
General . . . . .	4-36	4-33
Gauge glass breakage . . . . .	4-37	4-33
Installing gauge glasses . . . . .	4-38	4-33
Testing and care . . . . .	4-39	4-33
Steam pressure gauges . . . . .	4-40	4-33
Safety valves . . . . .	4-41	4-33
Blow-down pipes . . . . .	4-42	4-34
Dampers . . . . .	4-43	4-34
Section IX. Traps		
General . . . . .	4-44	4-34
Thermostatic traps . . . . .	4-45	4-34
Float and thermostatic traps and bucket traps . . . . .	4-46	4-36

	Paragraph	Page
Section X. Air Vents		
General . . . . .	4-47	4-38
Installation and operation . . . . .	4-48	4-38
Maintenance . . . . .	4-49	4-38
Typical operating difficulties . . . . .	4-50	4-39
Section XI. Steam Radiators		
General . . . . .	4-51	4-39
Installation . . . . .	4-52	4-39
Initial operation and cleaning . . . . .	4-53	4-39
Typical operating difficulties . . . . .	4-54	4-39
Section XII. Steam Unit Heaters		
General . . . . .	4-55	4-39
Installation . . . . .	4-56	4-42
Maintenance . . . . .	4-57	4-43
Typical operating difficulties . . . . .	4-58	4-43
Section XIII. Steam Heating Coils		
General . . . . .	4-59	4-43
Installation . . . . .	4-60	4-43
Initial operation and cleaning . . . . .	4-61	4-44
Maintenance . . . . .	4-62	4-44
Typical operating difficulties . . . . .	4-63	4-44
Section XIV. Steam Humidifiers		
General . . . . .	4-64	4-44
Installation of duct type humidifiers . . . . .	4-65	4-44
Installation of unit humidifiers . . . . .	4-66	4-45
Section XV. Pressure Reducing Valves		
Types . . . . .	4-67	4-45
Installation and initial operation . . . . .	4-68	4-46
Operation and maintenance . . . . .	4-69	4-47
Typical operating difficulties . . . . .	4-70	4-48
Section XVI. General Procedures for Operation and Maintenance		
General . . . . .	4-71	4-48
Valves and piping . . . . .	4-72	4-48
Water level . . . . .	4-73	4-48
Combustion equipment and controls . . . . .	474	4-48
Boiler structure . . . . .	4-75	4-49
Housekeeping . . . . .	4-76	4-49
Section XVII. Typical Steam Heating Operating Difficulties		
Water line fluctuation . . . . .	4-77	4-49
Low water level . . . . .	4-78	4-49
Loss of pressure . . . . .	4-79	4-49
Pounding in the system . . . . .	4-80	4-50
Heating unit malfunction . . . . .	4-81	4-50
Failure of space to heat . . . . .	4-82	4-50
Pump venting steam . . . . .	4-83	4-50
Pump venting water . . . . .	4-84	4-50
Steel boiler failure . . . . .	4-85	4-51
Cast iron boiler failure . . . . .	4-86	4-51
Boiler room smoke . . . . .	4-87	4-51
Section XVIII. Summer Lay-up Procedures		
General . . . . .	4-88	4-52
Draining system . . . . .	4-89	4-52
Boiler cleaning and lay up . . . . .	4-90	4-52
Stokers . . . . .	4-91	4-53
Oil burners . . . . .	4-92	4-54
Gas burners . . . . .	4-93	4-54
Pumps . . . . .	4-94	4-54
Valves and strainers . . . . .	4-95	4-54
Traps . . . . .	4-96	4-54
Controls and electrical connections . . . . .	4-97	4-55
Stack and breeching . . . . .	4-98	4-55

	<i>Paragraph</i>	<i>Page</i>
Section XIX. Energy Conservation		
Isolate off-line boilers . . . . .	4-99	4-55
Maintenance of pipe and boiler insulation . . . . .	4-100	4-56
Steam trap leak detection . . . . .	4-101	4-56
CHAPTER 5. HOT WATER HEATING SYSTEMS		
Section I. Gravity Systems		
General . . . . .	5-1	5-1
Equipment . . . . .	5-2	5-1
Startup . . . . .	5-3	5-2
Water level . . . . .	5-4	5-2
Inspection and maintenance . . . . .	5-5	5-2
Section II. Forced Circulation Systems		
General . . . . .	5-6	5-2
Equipment . . . . .	5-7	5-3
Piping systems . . . . .	5-8	5-4
Inspection and maintenance . . . . .	5-9	5-5
Section III. Hot Water Fan-Coil Units		
General . . . . .	5-10	5-6
Fan coil capacity control . . . . .	5-11	5-7
Electrical requirements . . . . .	5-12	5-7
Maintenance . . . . .	5-13	5-8
Section IV. Heat Exchangers		
General . . . . .	5-14	5-8
Installation . . . . .	5-15	5-8
Operation . . . . .	5-16	5-9
Maintenance . . . . .	5-17	5-9
Section V. Energy Conservation		
Hot water temperature reduction . . . . .	5-18	5-9
Night setback . . . . .	5-19	5-10
CHAPTER 6. WARM AIR SYSTEMS		
Section I. Description of Systems		
Warm air furnaces . . . . .	6-1	6-1
Gravity warm-air heating systems . . . . .	6-2	6-1
Forced warm-air heating systems . . . . .	6-3	6-2
Ratings of warm air furnaces . . . . .	6-4	6-4
Section II. Coal Fired Warm Air Furnaces		
Steel furnaces . . . . .	6-5	6-4
Cast iron furnaces . . . . .	6-6	6-5
Ratings and sizes . . . . .	6-7	6-5
Smokepipe . . . . .	6-8	6-5
Motor damper . . . . .	6-9	6-7
Chimney . . . . .	6-10	6-7
Section III. Oil-Fired Warm Air Furnaces		
General description . . . . .	6-11	6-8
Oil furnaces . . . . .	6-12	6-8
Oil-conversion furnace . . . . .	6-13	6-8
Section IV. Gas-Fired Warm Air Furnaces		
General . . . . .	6-14	6-12
Construction . . . . .	6-15	6-15
Furnace rating . . . . .	6-16	6-15
Central furnaces . . . . .	6-17	6-15
Vertical furnaces (hi-boy type) . . . . .	6-18	6-15
Horizontal furnaces . . . . .	6-19	6-16
Gas conversion furnaces . . . . .	6-20	6-17
Fully condensing furnaces . . . . .	6-21	6-18
Fully condensing furnace maintenance . . . . .	6-22	6-19
Pulse Combustion furnaces . . . . .	6-23	6-20
Pulse combustion furnace maintenance . . . . .	6-24	6-20
Automatic vent dampers . . . . .	6-25	6-21

	<i>Paragraph</i>	<i>Page</i>
Section V. Gas-Fired Unit Heaters		
General . . . . .	6-26	6-22
Description . . . . .	6-27	6-22
Operation . . . . .	6-28	6-22
Installation . . . . .	6-29	6-23
Section VI. Infrared Heaters		
Gas-fired infrared heaters . . . . .	6-30	6-24
Electric infrared heaters . . . . .	6-31	6-25
Oil-fired infrared heaters . . . . .	6-32	6-26
Precautions . . . . .	6-33	6-26
Maintenance . . . . .	6-34	6-27
Section VII. Operating and Maintenance Procedures		
General . . . . .	6-35	6-27
Blower and motor maintenance . . . . .	6-36	6-27
Air filter maintenance . . . . .	6-37	6-29
Humidifiers . . . . .	6-38	6-29
Blower and limit controls . . . . .	6-39	6-33
Troubleshooting . . . . .	6-40	6-33
Section VIII. Energy Conservation		
Space temperature setback . . . . .	6-41	6-34
Maintenance of duct insulation . . . . .	6-42	6-35
CHAPTER 7. AUTOMATIC CONTROLS		
Section I. General		
Types of controls and control systems . . . . .	7-1	7-1
Thermostats . . . . .	7-2	7-1
Primary controls . . . . .	7-3	7-1
Limit controls and safeties . . . . .	7-4	7-1
Section II. Operation and Maintenance		
General . . . . .	7-5	7-1
Thermostats . . . . .	7-6	7-2
Hand fired coal primary controls . . . . .	7-7	7-3
Coal stoker primary controls . . . . .	7-8	7-4
Oil burner primary controls . . . . .	7-9	7-4
Gas burner primary controls . . . . .	7-10	7-5
Limit controls . . . . .	7-11	7-8
Safety pilot and pilotstat . . . . .	7-12	7-10
Auxiliary controls . . . . .	7-13	7-10
APPENDIX A. RELATED PUBLICATIONS . . . . .		A-1
Appendix B. TROUBLESHOOTING UNDERFEED STOKERS . . . . .		B-1
Appendix C. TROUBLESHOOTING STEAM PRESSURE PUMPING SYSTEMS . . . . .		C-1
BIBLIOGRAPHY. . . . .		Bibliography-1
GLOSSARY. . . . .		Glossary-1
INDEX. . . . .		I-1

**List of Figures**

<i>Figure No.</i>	<i>Title</i>	<i>Page</i>
2-1.	Inside or elevated outside oil tank installation . . . . .	2-2
2-2.	Buried oil tank installation . . . . .	2-3
2-3.	Typical LPG installation . . . . .	2-6
3-1.	Single retort screw feed stoker . . . . .	3-1
3-2.	Grates for updraft furnaces . . . . .	3-3
3-3.	Downdraft furnace . . . . .	3-4
3-4.	Pressure atomizing gun type oil burner . . . . .	3-6
3-5.	Air atomizing gun type burner . . . . .	3-7
3-6.	Operating principles of low pressure gun type burner . . . . .	3-8
3-7.	Horizontal rotary oil burner . . . . .	3-9
3-8.	Settings of ignition points and nozzle for oil burners . . . . .	3-12
3-9.	Typical fuel oil piping . . . . .	3-14
3-10.	Automatic oil shut-off valve . . . . .	3-15
3-11.	Individual low pressure gas burner . . . . .	3-16
3-12.	Assembly of low pressure gas/oil burner . . . . .	3-16
3-13.	Typical installation of low pressure gas burner . . . . .	3-17

List of Figures—Continued

<i>Figure No.</i>	<i>Title</i>	<i>Page</i>
3-14.	Register burner (gas orifices centered in air stream) . . . . .	3-18
3-15.	Register burner (gas manifold dividing air stream) . . . . .	3-18
3-16.	Register burner (gas orifices outside air stream) . . . . .	3-18
3-17.	Typical fuel gas piping . . . . .	3-20
3-18.	Combustion efficiency chart . . . . .	3-22
3-19.	Typical heat load distribution . . . . .	3-23
4-1.	Gravity one-pipe vent system . . . . .	4-2
4-2.	Angle radiator valve . . . . .	4-2
4-3.	Automatic air vent . . . . .	4-3
4-4.	Barometric draft control . . . . .	4-3
4-5.	Two-pipe vapor system with return trap . . . . .	4-4
4-6.	Two-pipe vacuum system with vacuum pump . . . . .	4-7
4-7.	Positive displacement type vacuum pump . . . . .	4-7
4-8.	Centrifugal type vacuum pump . . . . .	4-8
4-9.	Sectional cast iron steam boiler . . . . .	4-9
4-10.	Firebox boiler . . . . .	4-11
4-11.	Horizontal return tubular boiler . . . . .	4-12
4-12.	Scotch type package unit boiler . . . . .	4-13
4-13.	Bent water-tube boiler . . . . .	4-14
4-14.	Hartford loop . . . . .	4-15
4-15.	Boiler return traps . . . . .	4-17
4-16.	Centrifugal pump and receiver set . . . . .	4-18
4-17.	Steam pressure pumping . . . . .	4-22
4-18.	Single vacuum pump installation . . . . .	4-23
4-19.	Single vacuum pump installation with accumulator tank . . . . .	4-24
4-20.	Water level regulator connections . . . . .	4-29
4-21.	Boiler water feeder piping connections . . . . .	4-29
4-22.	Boiler water feeder details . . . . .	4-31
4-23.	Stoppage area in boiler connection . . . . .	4-32
4-24.	Thermostatic trap (bellows type) . . . . .	4-34
4-25.	Thermostatic traps (diaphragm type) . . . . .	4-35
4-26.	Float and thermostatic (F & T) trap . . . . .	4-37
4-27.	Horizontal-blow unit heater . . . . .	4-40
4-28.	Vertical-blow unit heater . . . . .	4-41
4-29.	Floor mounted unit heater . . . . .	4-42
4-30.	Double-seated diaphragm pressure reducing valve . . . . .	4-46
4-31.	Steam pressure reducing station . . . . .	4-47
4-32.	Warm-up bypasses for a secured boiler . . . . .	4-56
4-33.	Steam trap test valve set-up . . . . .	4-57
5-1.	Open tank gravity system . . . . .	5-1
5-2.	Closed tank gravity system . . . . .	5-2
5-3.	Forced circulation system . . . . .	5-3
5-4.	Two-pipe distribution system . . . . .	5-4
5-5.	Series loop distribution system . . . . .	5-5
5-6.	Typical fan-coil unit . . . . .	5-6
5-7.	Typical fan-coil unit arrangements . . . . .	5-7
6-1.	Simple gravity warm air heating system . . . . .	6-1
6-2.	Forced warm air heating system . . . . .	6-2
6-3.	Central fan heating system . . . . .	6-3
6-4.	Perimeter loop delivery system . . . . .	6-3
6-5.	Coal fired steel forced warm air furnace . . . . .	6-4
6-6.	Draft control for anthracite coal furnace . . . . .	6-6
6-7.	Draft control for bituminous coal furnace . . . . .	6-7
6-8.	Typical oil fired furnace . . . . .	6-8
6-9.	Typical firepot construction . . . . .	6-8
6-10.	Round firepot . . . . .	6-9
6-11.	Square firepot . . . . .	6-10
6-12.	Wiring diagram, gravity furnace, constant ignition . . . . .	6-11
6-13.	Wiring diagram, forced air furnace, constant ignition . . . . .	6-12
6-14.	Gas fired central furnace . . . . .	6-13



List of Figures—Continued

<i>Figure No.</i>	<i>Title</i>	<i>Page</i>
6-15.	Gas fired elevated upflow furnace .....	6-14
6-16.	Duct type furnace .....	6-14
6-17.	Gas fired elevated downflow furnace .....	6-15
6-18.	Installation of a typical duct furnace .....	6-16
6-19.	Damper arrangement for duct furnace and cooling coil .....	6-17
6-20.	Draft hood .....	6-18
6-21.	Typical fully condensing furnace .....	6-19
6-22.	Pulse combustion process .....	6-20
6-23.	Gas fired unit heater .....	6-22
6-24.	Unit heater heat zone length .....	6-23
6-25.	Typical unit heater installation .....	6-24
6-26.	Gas fired infrared burners .....	6-25
6-27.	Electric infrared heating elements .....	6-26
6-28.	Fan bearing, pulley and belt adjustments .....	6-28
6-29.	Direct drive blower .....	6-29
6-30.	Pan type humidifier .....	6-30
6-31.	Centrifugal atomizer humidifier .....	6-31
6-32.	Steam spray humidifier .....	6-32
6-33.	Steam jacketed manifold humidifier .....	6-33
7-1.	Metal element thermostat .....	7-2
7-2.	Mercury switch thermostat .....	7-3
7-3.	Coal furnace primary control wiring .....	7-4
7-4.	Oil burner primary control wiring .....	7-5
7-5.	Gas burner primary control wiring .....	7-6
7-6.	Magnetic diaphragm gas valve .....	7-7
7-7.	Motorized gas valve .....	7-8
7-8.	Combination fan and limit control .....	7-8
7-9.	Immersion aquastat installation in hot water boiler .....	7-9
7-10.	Immersion aquastat installation in vertical riser .....	7-9
7-11.	Pressure control for steam boiler .....	7-10
7-12.	Pressure control on T-mounting .....	7-10

List of Tables

<i>Table No.</i>	<i>Title</i>	<i>Page</i>
2-1.	Heating value of typical coals .....	2-1
3-1.	Nozzle selection chart for No. 2 oil .....	3-11
6-1.	Recommended firebox sizes .....	6-9

## CHAPTER 1

### INTRODUCTION

---

#### 1-1. Purpose and scope.

*a.* This technical manual provides basic information for facilities personnel regarding the operation and maintenance of small heating systems and related equipment. Generally, the manual covers low pressure steam boilers (less than 15 psig), low pressure hot water boilers (less than 30 psig), space heaters, unit heaters, and warm air furnaces. The term "small" is used in the context of this manual to differentiate from the high pressure systems and equipment that are covered in detail in TM 5-650, Central Boiler Plants.

*b.* This manual makes reference to specific types of equipment commonly in use at Army installations. System and equipment descriptions contained in the manual are general in nature. Equipment manufacturers' technical literature and manuals should also be used for reference, training, and troubleshooting specific equipment.

#### 1-2. References.

Related publications are listed in Appendix A.

#### 1-3. Abbreviations and terms.

Abbreviations and special terms used in this manual are explained in the Glossary.

#### 1-4. Organization and responsibility.

The operating and maintenance personnel for heating systems are organized in accordance with the applicable Army regulations and staffing guides. Supply and administrative support are provided by other divisions, branches, and/or sections within the Directorate of Engineering and Housing. There are significant differences at the installations in the quantity, type, and use of equipment. Therefore, personnel responsibilities may vary locally to provide the necessary operating and maintenance functions. In some cases, an individual may well perform both operation and maintenance. In all instances, coordination is required with the work management functions (planning, estimating, scheduling, recording data, etc.).

*a. Operating personnel.* Operating personnel have the responsibility to fire the equipment in the most efficient and economical manner. This includes the performance of equipment adjustments and simple routine maintenance work consistent with good operating practice.

*b. Maintenance personnel.* Maintenance personnel have the responsibility to maintain heating

systems in good operating condition. This includes keeping equipment information files and necessary records of the maintenance work performed.

#### 1-5. Systems overview.

The main heat conveying media for space heating systems are steam, hot water, and warm air.

*a. Steam.* Water heated to the boiling point evaporates and produces steam as long as heat is added. If the heat is removed or reduced, evaporation will stop or decrease. The quantity of heat contained in each pound of steam depends on its pressure and temperature. Steam can be generated and used as either saturated or superheated steam. Chapter 4 gives detailed information on steam systems.

(1) *Saturated steam.* For each steam pressure, there is a specific temperature at which the steam will become saturated. When steam is saturated, a drop in temperature or an increase in pressure will cause part of the steam to revert to water. There are two types of saturated steam: dry, i.e., without moisture; and wet, which is intermingled with moisture, mist or spray. Saturated steam is commonly used for space heating and process heat.

(2) *Superheated steam.* When steam has a temperature higher than its corresponding saturation pressure, it is called superheated steam. The difference between the temperature of superheated steam and its saturation temperature is called the superheat. Usually, superheated steam is generated in central heating plants when necessary to avoid condensation in the steam lines of the plant and the distribution system, or to drive steam turbines. Normally in such instances, not more than 50F superheat is imparted to the steam.

(3) *Total heat content.* A certain amount of heat is needed to change water into steam. The specific amount depends on the initial condition of the water and the desired pressure and temperature of the steam. The amount of heat required to convert water at 32F into steam at a specific pressure and temperature is called the total heat content (or enthalpy) of the steam at that particular pressure and temperature. As pressure rises from atmospheric conditions up to about 450 psia, the total heat content of dry saturated steam increases. At higher pressures, the total heat decreases as pressure increases. However, superheating increases the total heat content of the steam at any

pressure. Any thermodynamic steam table will show the total heat content of steam at different pressures and temperatures.

*b. Hot water.* Hot water is a very useful carrier of heat. Circulating in a closed system, the water absorbs heat in a boiler or heat exchanger and releases it to the heat using equipment. Hot water systems can be classified as high temperature, medium temperature, and low temperature. Chapter 5 gives detailed information on hot water systems.

(1) *High temperature water.* High temperature water (HTW), above 350F is usually generated in central heating plants and then delivered to the consumers by a distribution system. A heat exchanger is normally used in each building to convert the HTW into low temperature water for use in space heating.

(2) *Medium temperature water.* Supply water temperature for this type system ranges from 250F to 350F and is used for distribution systems, large space heaters, absorption refrigeration, and industrial purposes.

(3) *Low temperature water.* Supply water temperature for this type system is below 250F and is used for space heating. Generally, this manual covers low temperature hot water systems and equipment.

*c. Warm air.* Unlike steam and hot water, which are fed through pipes to space heating equipment from which heat is dispensed by radiation and convection, warm air supplies direct heat. In warm air systems, the cold air is heated by blowing it through a furnace casing or heat exchanger. The warmed air is then distributed through air ducts to

the areas where heating is required. Chapter 6 gives detailed information on warm air systems.

### 1-6. Energy conservation policy.

*a.* All Army installations should have a management improvement program that includes policies and guidelines relating to the efficient use and conservation of utilities. Conservation measures should be implemented by supervisory, operating and maintenance personnel and by the users. The importance of keeping equipment properly used, adjusted, and maintained cannot be overemphasized.

*b.* Periodic reviews should be made of all factors influencing fuel selection to determine whether the fuel used still remains the most cost efficient for a particular installation. Also, the feasibility of improving or modernizing firing methods for current fuels should be considered.

*c.* The greatest boiler operating efficiency is obtained when units are operated at or near their full load ratings. Therefore, two boilers should never be operated if one can carry the load without exceeding its rating. Supervisors should review daily operating logs to insure proper boiler operation. Give specific attention to the percentage of CO<sub>2</sub> in the flue gas and temperature of the gas. These are good indicators of operating efficiency and depend on the proper balance between the rate of fuel feed, combustion air supply, draft, and stack temperature.

*d.* Periodically inspect heated facilities. Observe thermostat settings and advise users when incorrect settings are found. Correct settings may be posted. Also, identify those facilities where excessive heat is lost due to improper insulation and open doors or windows and take corrective actions.

## CHAPTER 2

## FUELS

## Section I. COAL

## 2-1. General.

Coal is a mineral originated from decayed trees, ferns, and other types of vegetation. It is composed of varying proportions of carbon, hydrogen, oxygen, nitrogen, sulfur, and several noncombustible materials which make up the ash. The ash is composed mainly of silica, alumina, iron, lime, and small quantities of magnesia. Coal used as commercial fuel consists primarily of volatile matter, fixed carbon, sulfur, ash, and water. The types of coal used at military installations are anthracite, bituminous, sub-bituminous and lignite. Table 2-1 gives the heating value for these coals.

Table 2-1. Heating Value of Typical Coals

Classification	Group	Heating Value (BTU/lb.)
Anthracitic.....	Metal anthracite.....	12,745
	Anthracite.....	12,925
	Semianthracite.....	11,925
Bituminous.....	Low volatile.....	13,800
	Med. volatile.....	13,720
	High volatile A.....	12,850
	High volatile B.....	12,600
	High volatile C.....	11,340
Sub-bituminous.....	Type A.....	11,140
	Type B.....	9,345
	Type C.....	8,320

## Section II. FUEL OILS

## 2-2. General.

Fuel oils are derived from crude petroleum. Crude petroleum is a mixture of hydrocarbons and small amounts of nitrogen, sulfur, and vanadium; the amount of each substance present varies with the petroleum source. There are two types of crude petroleum available in the United States, paraffin-base and asphalt- or naphthene-base. Paraffin-base crudes are found in the Appalachian mountain range and in the Midwest. Asphalt-base crudes are found in Texas and California. Paraffin-base crudes yield many valuable lubricating oils. The asphalt-base crudes furnish the major part of commercial fuel oil used in the United States. The various products derived from petroleum, including fuel oils, are separated by fractional distillation. This is a process by which liquids with different boiling points are separated from solution by repeatedly evaporating and condensing portions of the mixture.

## 2-3. Classification of fuel oils.

In general, fuel oils can be divided into two major classifications: distillate and residual.

*a. Distillate fuel oils.* When the fractional distillation process is applied to crude petroleum, the gaseous and light substances boil off first, followed by gasoline, kerosene, and then light and heavy distillate fuel oils (gas oils).

*b. Residual fuel oils.* When marketed as a fuel, the "bottom" or residual material from the distillation process is called residual fuel oil. Since crude petroleum from various sources differ widely in composition, there is considerable difference in these oils. In general, they are heavy, dark and viscous compared to the lighter and more fluid distillate oils.

*c. Commercial grade fuel oils.* Commercial-grade fuel oils are generally classified according to physical characteristics and use. Current standards designate five basic grades of heating fuel oil: Nos. 1, 2, 4, 5, and 6.

(1) *No. 1 oil.* This is a light volatile distillate with essentially the same burning characteristics as kerosene. It is generally used in vaporizing pot type burners under domestic heating boilers and furnaces. The average heating value is approximately 135,000 Btu per gallon.

(2) *No. 2 oil.* This is slightly heavier distillate than No. 1 oil. It is used as domestic fuel oil in some types of vaporizing burners and in high and low pressure atomizing burners. Its average heating value is approximately 139,000 Btu per gallon.

(3) *No. 4 oil.* This oil may be 100% residual material. However, for marketing purposes, it is generally blended with sufficient distillate stock to meet viscosity and flashpoint requirements for the grade. Grade No. 4 oil, like grades No. 1 and 2,

atomizes under normal conditions without heat. The approximate heating value is 145,000 Btu per gallon.

(4) *No. 5 oil.* This oil, like No. 4, can be a straight residual product; but it is also marketed in many areas as a blend of distillate and residual stocks. No. 5 oil has medium viscosity. Installations that use it generally have oil heating facilities. The heating value of No. 5 oil is approximately 150,000 Btu per gallon.

(5) *No. 6 oil.* No. 6 oil is a high viscosity, residual material. It is used in large commercial and industrial steam generating plants and in certain industrial processing operations. Its use requires pre-heating facilities for transportation unloading, pumping, and atomization. The heating value averages approximately 154,000 Btu per gallon.

d. *Diesel fuel oils.* Diesel fuel oils vary widely in

characteristics. The cetane number, a measure of the ignition quality of the fuel which influences engine roughness, varies from a minimum of 40 for grades 1-0 and 2-0 to 30 for grade No. 4-0. Diesel fuels are normally used for firing stationary engines and not for heating.

**2-4. Oil tanks.**

Tank installation is largely governed by local conditions. Listed here are the principles of tank installation that give greatest freedom from service problems. Adhere as closely to these recommendations as local conditions permit.

a. *Indoor or elevated outdoor tanks.* Whenever possible, install single-pipe gravity oil feed inside or elevated outside tanks. (See figure 2-1.) Use a 1/4-inch globe valve at the tank rather than a larger valve, which may cause "tank hum".

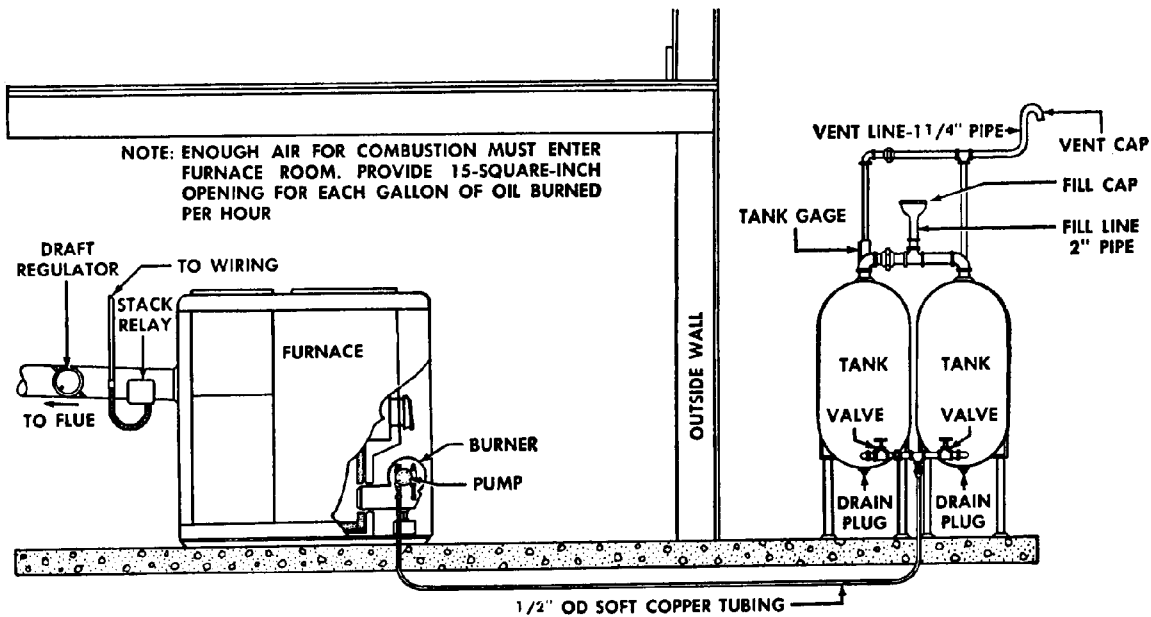

Figure 2-1. Inside or elevated outside oil tank installation.

b. *Tubing.* For all installations, use a continuous piece of 1/2-inch copper tubing from the oil tank to the burner and a similar piece for the return when required. The principle is to minimize the number of joints and to thus minimize the possibility of air or oil leaks.

c. *Overhead piping.* For inside installations where it is necessary to run the piping between the tank and burner overhead (when the burner is either above or below tank level), the two-pipe system is recommended. This system requires the use of a two-stage pump.

d. *Underground outside tank.* Install underground outside tanks according to the following instructions and figure 2-2:

(1) Install a continuous piece of copper tubing from a point 3 inches above the bottom of the tank up through a compression fitting in the top plug, over into the basement, and into an approved check valve. Where possible, drop this feed-line inside the building to a point level with the bottom of the tank before the check valve.

(2) Use a 1/2-inch IPS straight compression connector (for 1/2-inch tubing) for running the 1/2-inch copper tubing through the tank cap. Drill out the

inside of the connector, allowing the tubing to slip completely through; drill and tap the tank cap for 1/2-inch IPS to receive the connector. Slip the tubing through the connector and down to the proper point 3 inches above the tank bottom. Tighten the connector, locking the tubing in the proper position.

(3) Install the return line in the opposite end of the tank, using the technique described for the suction line, above. Carry it to within 5 inches of the bottom. This creates an oil seal between the

two lines and any agitation caused by return oil is safely away from the suction line.

(4) A 2-inch fill line and 1 1/4-inch vent line are recommended. Carry the vent well above ground and terminate it with a weather-proof cap. Pitch the vent line down toward the tank.

(5) Use special pipe dope on all iron pipe fittings that carry oil.

(6) Treat all underground outside tank and piping surfaces with a standard commercial corrosion resistant paint or preparation.

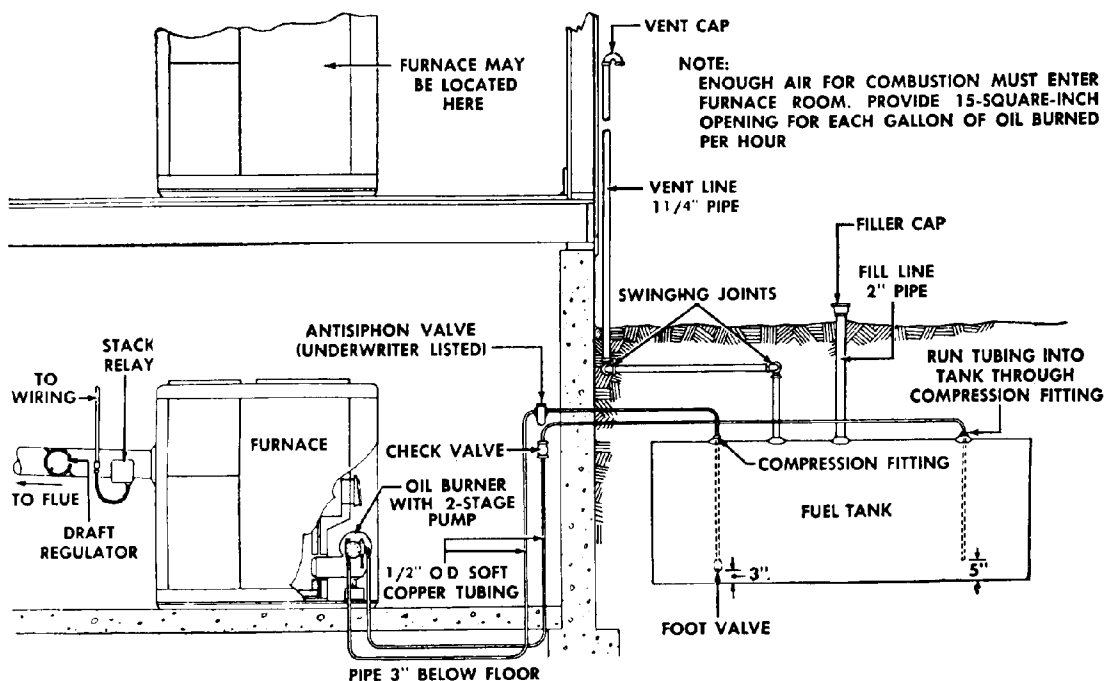

Figure 2-2. Buried oil tank installation.

### Section III. NATURAL GAS

#### 2-5. General.

Natural gas is the most commonly used gaseous fuel in small heating systems. Natural gas is usually odorless and requires the addition of odorants to permit detection. According to its content of hydrogen sulfide it is known as "sweet" or "sour". Sour natural gas is normally thought of as gas containing more than 1.5 grains of hydrogen sulfide per 100 cubic feet of gas. Its heat value varies from approximately 950 to 1,150 Btu per cubic foot.

#### 2-6. Gas handling and storage.

The supply company normally delivers natural gas to consumers by pipeline. Storage tanks therefore

are not normally included in a consumer's gas system installation. A gas handling system consists of all or some of the following items:

a. *Pressure reduction station.* This is used to reduce the supply pressure and maintain a relatively constant pressure despite variations in supply.

b. *Low pressure safety shut-off valve.* The function of this valve is to interrupt gas flow to burners if the supply pressure drops below a predetermined value.

c. *Flow meter.* This meter indicates and records the volume of gas consumption.

*d. Pressure and temperature gauges.* These aid the operator to control and supervise operation of the equipment.

*e. Vents, drains, moisture separators, and relief valves.* Vents are used to purge the system and remove all air and inert gases during filling procedures. Moisture separators and drains remove condensate from the system; relief valves prevent abnormally high gas pressure if the system reducing valve malfunctions.

## 2-7. Gas handling precautions.

Natural gas is toxic, and its presence in appreciable quantities is a serious health hazard. Gas diffuses readily in air resulting in possibly explosive mixtures. Because of these characteristics, be sure there are no leaks present and exercise caution when lighting gas fired equipment.

## Section IV. LIQUEFIED PETROLEUM GAS

### 2-8. General.

Because of the special characteristics of liquefied petroleum gas (LPG), it must be handled and stored with great care in properly designed tanks and equipment. If handled carelessly, whether through failure to understand its characteristics or for other reasons, this fuel presents a definite hazard to life and property.

### 2-9. Characteristics.

The principal commercial products are butane, isobutane, and propane. They are closely related, are all derived from natural gas or petroleum refining gas, and are on the border line between a liquid and a gaseous state at atmospheric pressure.

*a. Vaporizing point.* At ordinary atmospheric pressure with necessary heat of vaporization added, butane will boil at 31F. The boiling point of isobutane is 10F and the boiling point of propane is -44F.

(1) Under pressures higher than atmospheric the boiling points are higher than at atmospheric pressure. The fuel, if placed under pressure, can be held in a liquid state and transported by tank car, truck or cylinders. However, LPG must be in the vaporized or gaseous state to be used as a fuel.

(2) To change these petroleum products from a liquid to a gaseous state the liquid must be maintained at the boiling point and the latent heat to produce vapor must be added. For small installations, heat from the atmosphere in warm climates or from the ground in colder climates, is usually sufficient to vaporize the liquid. In cold climates, where temperatures of the liquid will drop below its boiling point, a vaporizer must be used; that is, the liquid is passed through a heating device which will apply sufficient heat to vaporize it. The gas flows from the tank through a valve and pressure regulator. The regulator reduces tank pressure to the low pressure required to operate appliances. Although pressure on the tank may be 100 psi, the pressure regulator reduces this pressure to about 6 to 8 ounces, or less, per square inch.

*b. Specific gravity.* Natural gas is lighter than air and in case of a leak, will float away and be dissipated in the air. However, vapors from liquefied petroleum gases are heavier than air and therefore tend to settle in low points. In making installations, this must be carefully considered and bottom ventilation provided in basements in which a furnace or appliance is used. Basement installations are definitely not recommended and must not be made unless absolutely necessary and all safety aspects are considered.

### 2-10. Specifications.

*a. Propane.* As a gas (60F at 14.7 psi), the heating value of propane is approximately 2,500 Btu per cubic foot. As a liquid (-45F at 14.7 psi), the heating value of propane is 91,800 Btu per gallon or 21,560 Btu per pound.

*b. Butane and isobutane.* As a gas (60F at 14.7 psi), the heating value of butane and isobutane is 3,100 Btu per cubic foot. As a liquid (12F at 14.7 psi), the heating value is 102,400 Btu per gallon, or 21,500 Btu per pound.

### 2-11. LPG storage and handling.

At Army installations, gas handling and storage equipment upstream of the tank pressure reducing valve are usually the property of the gas supplier. The pressure reducing valve and all equipment downstream is government property. This may include a pressure reducing station, low pressure safety shutoff, flow meter, pressure and temperature gauges, vents, drains, moisture separators and relief valves. Do not tamper with nongovernment property. Most fuel supplied as LPG is commonly designed to conform with the properties of propane. Equipment designed for handling and storing butane (a lower pressure gas under similar operating conditions) must not be used for propane. The vapor pressure of propane at 60F temperature is 92 psig; if the temperature rises to 100F the vapor pressure increases rapidly with temperature rises.

Equipment for storing and handling propane is rated at 250 psi to provide a reasonable margin of safety.

*a. LPG storage.* LPG is stored in pressure tanks with the gas vapor filling the upper portion. Tanks are fitted with a liquid line and a vapor line connected to the vaporizing equipment (if used) and a liquid line and a vapor line connected to the unloading pit. In addition, the tank is usually provided with a safety valve, a thermometer well, a pressure gauge, a 90 percent full indicator, and a sliptube type of gauge for determining the liquid level in the tank. Any valve pit or other below grade location where leakage of gas or liquid might occur, is vented by a pipe stack tall enough to carry off the vapors. Because LPG is heavier than air, the vent stack must have a mechanical exhauster operated by either power or wind.

*b. LPG handling precautions.* When handling LPG, take the following precautions:

(1) Any work required in a fume-filled or contaminated area must conform to all safety regulations to eliminate personnel hazards. LPG is odorless, colorless, tasteless; it is odorized with the same odorants as natural gas. Although LPG is not poisonous, exposure to a room or pit full of gas causes a synthetic intoxication; and if exposure is prolonged, asphyxiation (smothering) results. LPG is heavier than air and will hang to the floor or ground.

(2) Avoid contacting the liquid with the hands or any part of the body. When LPG is released from a container and evaporated, it absorbs heat from anything it touches. Therefore, any part of the body which comes in contact with the liquid may be frozen. If this happens, as a first aid measure, thaw the affected part immediately by applying cold water or cold pads. Then treat exactly as a burn and get medical assistance.

(3) Avoid leaks. LPG will ignite only when it vaporizes and mixes with sufficient air to form a combustible mixture. Vapor leaks permit such mixtures to form. A leak will burn close to or at a distance from the opening, depending on the gas pressure and the size of the opening.

(4) Comply with rules and regulations governing transportation, storage, and dispensing of LPG.

Most petroleum derivatives such as kerosene, gasoline, natural gas, or LPG are combustible and, when not handled carefully, can be explosive and dangerous. When properly handled, suitably housed, and controlled, they can be used safely.

*c. LPG piping.* Liquefied petroleum gas acts as a solvent of all petroleum products; for that reason, use a special pipe dope containing no mineral oils or rubber. Because gases revert to their liquid state when cooled below respective boiling points, bury gas lines below the frost line. Never run LPG lines under concrete floors, and run under buildings only when absolutely necessary. Bury supply lines parallel to and at least two feet away from building walls. Install separate takeoffs and risers for each appliance and enter the building at the nearest practicable point to the appliance or furnace. Whenever possible, run lines inside buildings using a single length of pipe without joints.

*d. Installation and control of LPO systems.* For furnace installations, pressure regulators are not required at the furnace. Take the pressure reading at the furnace manifold and set the pressure at the regulator on the liquefied petroleum tank or atomizer. Furnaces using LPG require a manifold pressure of 11 to 13 inches water gauge, whereas with natural gas, a pressure of 2.5 to 5 inches water gauge is required. Follow manufacturer's recommendations covering manifold pressures for liquefied petroleum gas at the furnace. If gas lines serving other appliances, such as water heaters, space heaters, or cooking appliances are taken from the line serving the furnace, an approved double-diaphragm, low-pressure regulator is installed in the take-off line or lines to reduce pressure in these lines to the required pressure. These regulators are vented to the outside of the building, not under the pilot as with natural gas. (See figure 2-3.) Furnaces are equipped with 100-percent-cut-off valves. That is, all gas, including pilot gas, is cut off if the pilot is extinguished. Furnaces with two or more pilots have a separate pilotstat for each pilot, all wired in series. Each of the small solenoid valves installed in the pilot line is wired in parallel with the usual main burner electric solenoid valve. If any pilot should go out, its pilotstat breaks the circuit and shuts off the gas supply for all main burners and pilots.



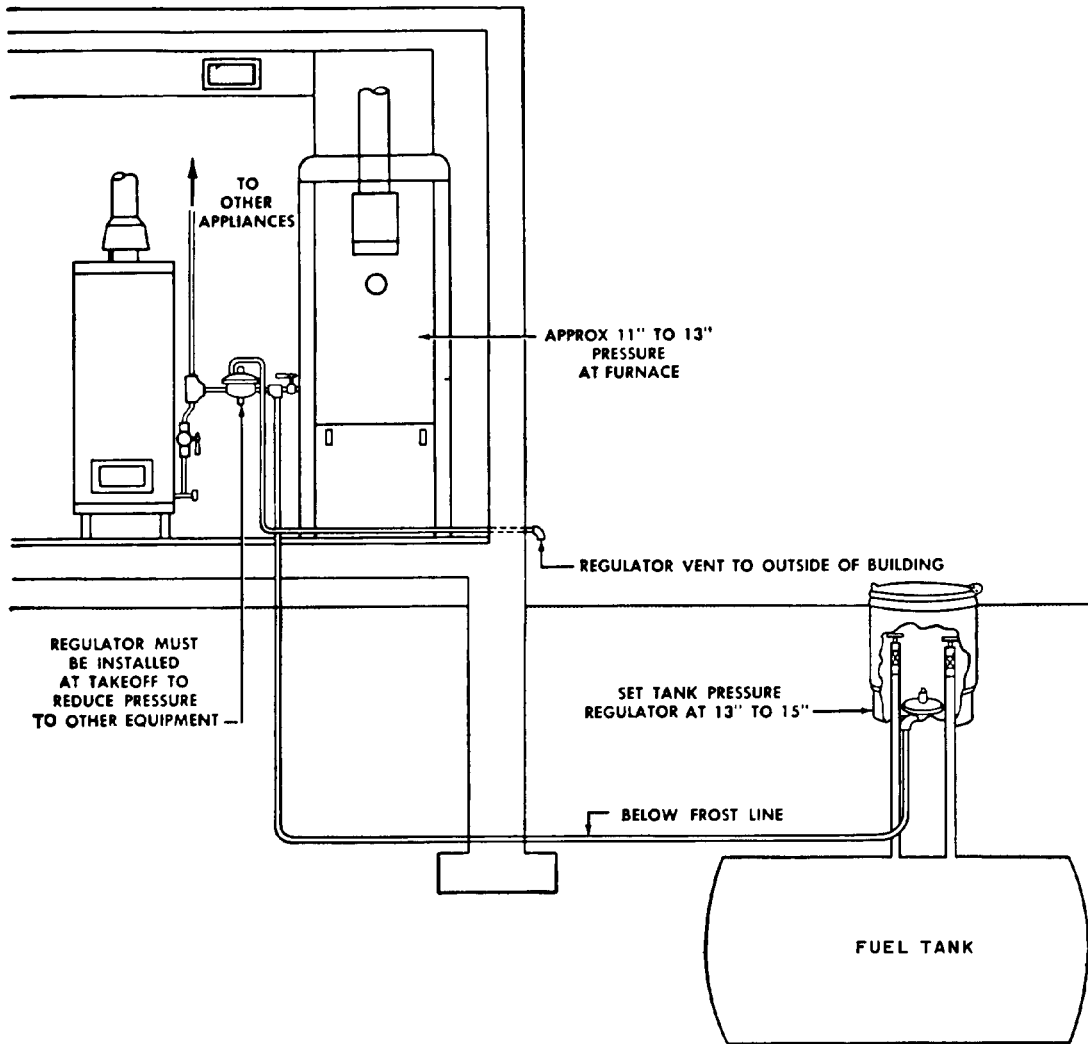

Figure 2-3. Typical LPG installation.

## CHAPTER 3

## FUEL BURNING EQUIPMENT

## Section I. COAL STOKERS

**3-1. General.**

Stokers may be divided into four general classes: underfeed, spreader, travelling or chain grate, and overfeed. Generally, domestic type boilers use single-retort underfeed stokers and therefore, only this type is discussed.

**3-2. Single-retort underfeed stokers.**

This unit consists essentially of a coal hopper, a screw for conveying coal from hopper to retort, a fan which supplies air for combustion, a transmis-

sion for driving the coal feed worm and electric motors supplying power for coal feed and air supply. Air for combustion is admitted to the fuel through tuyeres at the top of the retort. The retort may be either round or rectangular. The stoker feeds coal to the furnace intermittently in accordance with temperature or pressure demands. A special time or holdfire control is used to maintain a fire during periods when heat is not required. Figure 3-1 shows a typical arrangement.

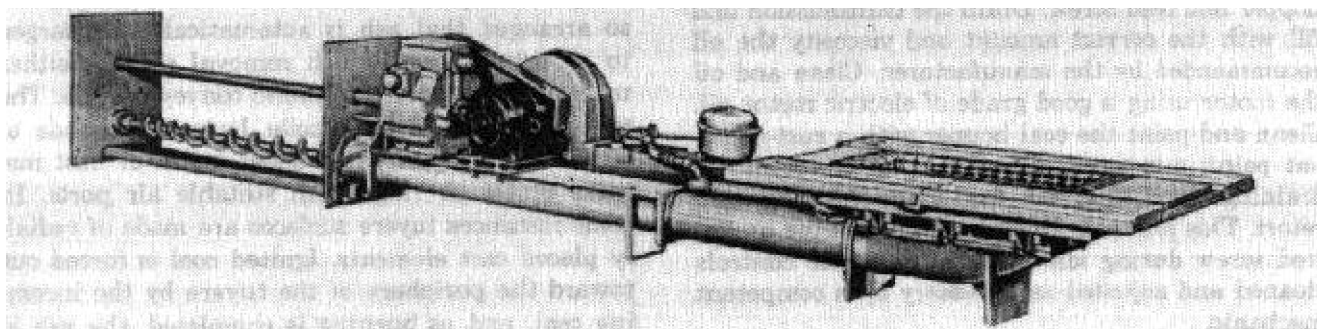

Figure 3-1. Single retort screw feed stoker.

**3-3. Operation.**

Two main causes of excessive outage and maintenance are sustained or frequent overloading of stoker and operating with insufficient draft. Where prolonged overloading is unavoidable, good operation and careful attention to maintenance are important.

*a. Fire.* Following are the main points to keep in mind for maintaining a good fire.

(1) Keep fire out of retort. This condition can result from a fuel bed which is too thin, from banking with insufficient fuel or from running with an empty hopper.

(2) Avoid working the fire too much. If the fuel bed requires leveling off, use a light rake or bar on the surface of the fire. Never slice the fire as is done in hand firing by pushing a bar under the fire and raising it through the fuel bed.

(3) Be sure to feed sufficient fuel when banking. It may be necessary to renew the fuel supply during long banking periods.

(4) The depth of the fuel bed is very important. If too thin, the fire may burn down into the retort

and damage it. If too heavy, poor air distribution will result, causing spotty, uneven fire, holes in the fuel bed, smoke, and reduced efficiency. The correct depth of the fuel bed above the top of the retort may be anywhere from 4 to 8 inches, depending upon analysis and burning characteristics of the coal used.

*b. Draft.* Check with draft gauge and a carbon dioxide (CO<sub>2</sub>) indicator.

(1) Operate with a slight draft, preferably not less than 0.02 inch water gauge just above the fuel bed. Positive pressure will cause excessive temperatures at grates and lower wall areas.

(2) Maintain a proper supply of air at all times. Either too much or too little air will reduce efficiency and capacity.

(3) Do not force the stoker beyond the capacity of the stack to carry away flue gases.

(4) Keep wind boxes properly sealed to prevent leakage of air into the ash pit and furnace.

(5) If the draft is insufficient, check leaks in setting and losses through boiler and flue connections. Check the position of the boiler damper.

*c. Cleaning.*

(1) Remove siftings from wind boxes often enough to prevent any possibility of fire under the hearth. Frequency of cleaning depends upon type of fuel used, but wind boxes should be inspected often.

(2) Keep the front of the stoker clean to prevent contamination of lubricants and excessive wear on moving parts.

*d. Lubrication.* Use proper lubricants at sufficiently frequent intervals at all points requiring lubrication to avoid unnecessary outages and excessive maintenance. Prepare a definite schedule for lubrication and adhere to it regularly. Manufacturer's literature should be consulted when setting up the lubrication schedule.

*e. Lay-up.* When stokers are to be out of service for long periods of time, remove coal from the hopper and feed screw. Drain the transmission and fill with the correct amount and viscosity the oil recommended by the manufacturer. Clean and oil the motor using a good grade of electric motor oil. Clean and paint the coal hopper with a rust-resistant paint; mix sawdust and fuel oil or crankcase drainings and fill the feed-screw housing and retort. This prevents moisture from forming on the feed screw during idle periods. Have the controls cleaned and adjusted as necessary by a competent mechanic.

**3-4. Inspection and maintenance procedures.**

Following is a description of good practices for inspection and maintenance of coal stokers:

*a.* Inspect all accessible parts of the stoker often. Inspect thoroughly at scheduled intervals.

*b.* During routine and daily inspections, look especially for loose bolts and loose connections in

moving parts. Where movement is transmitted by a shear pin or safety release be sure there is no binding which prevents protective device from serving its function. Make repairs or replacements promptly.

*c.* When the stoker is shut down, make a thorough inspection. Check for wear on moving parts and check alignment. Check condition of dump grates. On stokers equipped with moving grate bars, check movement of bars to see that proper clearances are maintained. Overall clearances to provide for elongation of grate bars should be 1 1/2 inches on small stokers, and up to 2 inches on larger stokers.

*d.* Inspection and maintenance procedures for anthracite coal stokers in domestic type installations are similar to that for bituminous coal stokers previously described. However, some units are so arranged that ash is automatically discharged to an ashpit, from which removal may be either manual or by small automatic conveyor units. The tuyere surface of anthracite burners is made of either formed perforated sheet metal or cast metallic plates or rings with suitable air ports. In some instances tuyere surfaces are made of radially placed cast elements. Ignited coal is forced out toward the periphery of the tuyere by the incoming coal, and as burning is completed, the ash is discharged by gravity from the ash ring into an ashpit under the stoker retort. To avoid discharge of unburned coal to the ashpit, adjust the rate of coal feed and air supply carefully.

**3-5. Troubleshooting underfeed stokers.**

A troubleshooting chart for underfeed stokers is in appendix B.

**Section II. HAND-FIRED COAL BURNERS**

**3-6. General.**

In coal burning installations, units may be hand fired using either updraft or downdraft type furnaces. In both types, coal is fed manually onto grate bars forming the bed of the furnace. There are limitations to the combustion capacity obtainable with hand firing in a single heating unit; this firing method is employed only with the smallest units.

**3-7. Furnace types.**

*a. Updraft furnace.* Updraft type furnaces are most commonly used in the types of military in-

stallations covered by this manual. Primary air enters the lower portion of the furnace and passes up through the fuel bed. Stationary grate bars permit primary air to rise and ash to drop through. The fire must be cleaned manually with special tools. Sometimes dumping grates are used which permit mechanical removal of ash and refuse without opening fire doors. Typical grates used in this type of furnace are shown in figure 3-2.

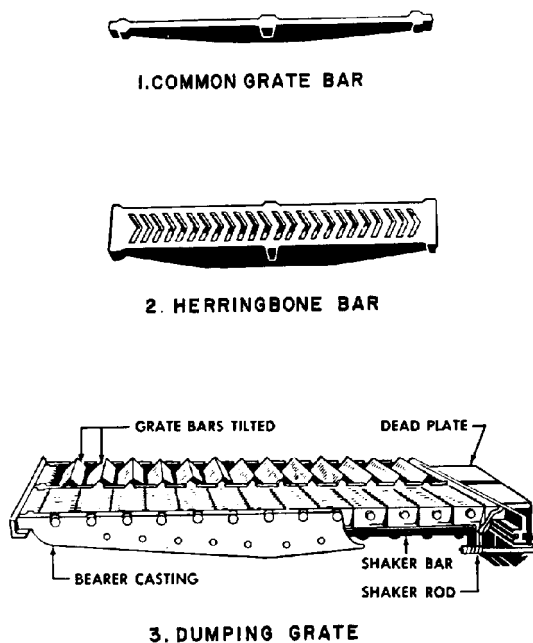

Figure 3-2. Grates for updraft furnaces.

The grate, which supports the fuel bed and admits air for combustion, is made up of a number of bars supported at the rear by the bridge wall and at the front by a dead plate which, in turn, is supported by the brickwork. The grate bars are held in place by their own weight. The types of grates commonly used for updraft furnaces are the common grate bar, herringbone or tupper bar and dumping grate.

(1) The common grate bar (figure 3-2.1) is usually about three feet long and three inches deep at its center. The width varies from  $\frac{3}{4}$  inch at the top to  $\frac{3}{4}$  inch at the bottom. This grate allows the air to

rise and the ashes to drop through.

(2) The herringbone or tupper bar (figure 3-2.2) is about six inches wide with side flanges to prevent warping. Each bar has V-shaped openings running the length of the bar for passage of air and ash.

(3) The dumping grate (figure 3-2.3) permits removal of the ash and refuse without opening the firing doors and also reduces the amount of labor required. Tools used to handle the fire are the hoe, slice bar, and rake. The hoe and slice bar are used to clean the fire and break the clinkers. The rake is used to level off the fuel bed. The bridge wall keeps the fire on the grates, assists in mixing the air and gases, and directs them over the heating surface.

*b. Downdraft furnace.* The downdraft furnace (figure 3-3) has both an upper and lower grate and gets its name from the fact that primary air passes down through the fuel on the upper grate. The upper grate consists of a series of tubes which extend from the front water leg to a header in the rear. This header extends from one side water leg to the other, and supports a refractory wall which forms the back of the downdraft furnace. The lower grate is formed by common grate bars or by a regular shaking grate. Coal is fired through the top doors onto the upper or downdraft grate where it burns. Incandescent fuel drops through to the lower grate where it keeps a bright fire. Air is admitted above the upper grate and mixes with the distilled gases from the coking coal as it passes down through the upper grate. The incandescent fuel bed on the lower grate helps to complete the combustion of volatile matter given off by the coal and reduces emission of smoke from the boiler. This type of furnace cannot be used where high rates of firing are necessary.

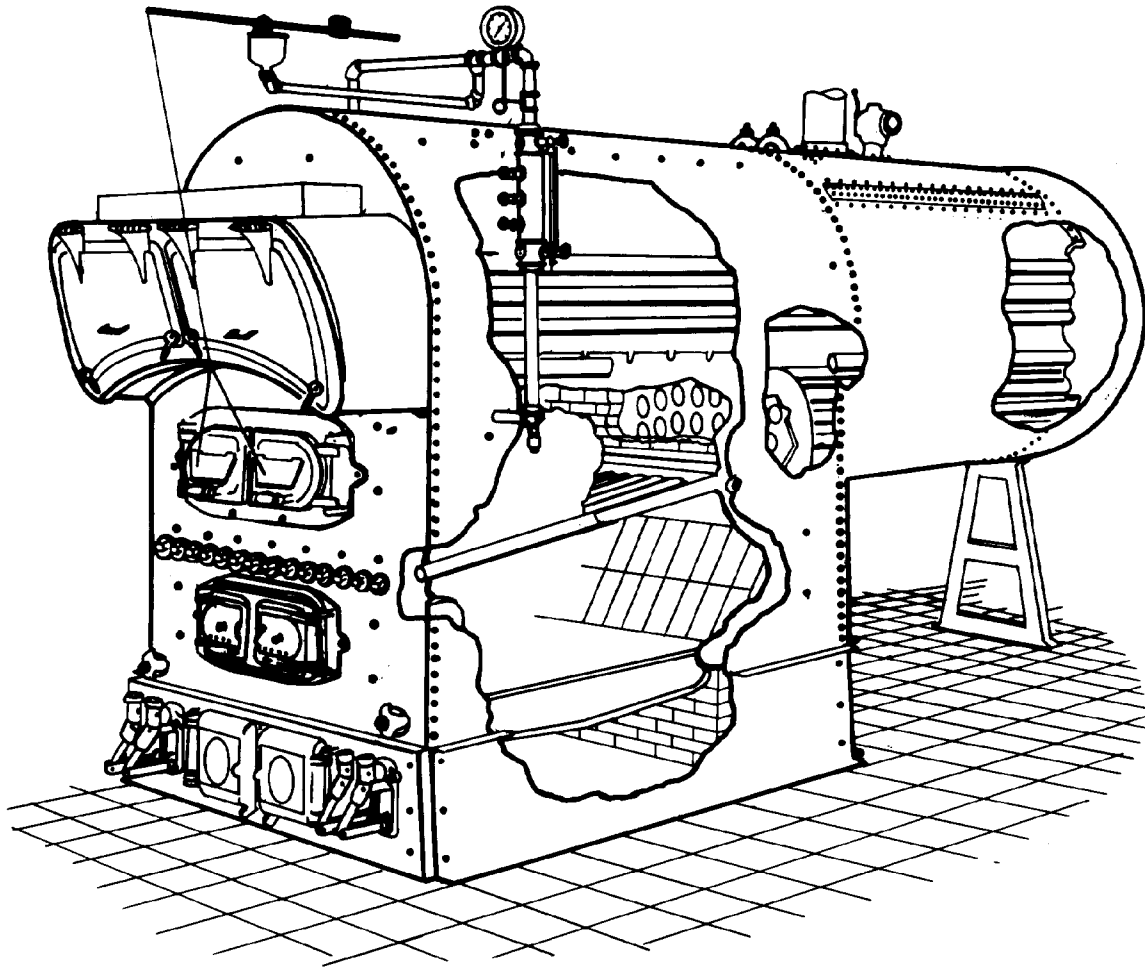

Figure 3-3. Downdraft furnace.

### 3-8. Operation.

In hand firing, the best condition of the fuel bed is obtained when coal is fired frequently, in small amounts, with proper distribution; when caked masses are broken up immediately; and when ash and clinkers are not allowed to clog the bed. In general, there are three methods of hand firing.

*a. Spread firing.* A small amount of the fresh coal is distributed evenly each time over the entire surface of the bed. This method is commonly adopted with anthracite and other low-volatile coals.

*b. Alternate firing.* New coal is placed on selected areas of the grate each time. The coal may be placed alternately on one half of the grate, on alternate strips, or on alternate spots. This method of stoking is particularly suited to non-caking coals.

*c. Coking-firing.* Fresh fuel is placed on the front edge of the fuel bed and allowed to cake there, the volatile matter passing back over the hot

bed. After the distillation is complete, the remaining carbonized fuel is pushed back and distributed over the bed. This method, while effective, does not permit obtaining high rates of combustion compared to the other methods.

(1) The best firing condition for a hand fired furnace is obtained when fresh coal is added at or shortly after completion of distillation of the previous charge. Optimum intervals between firing are approximately ten minutes for bituminous coals, and slightly less frequently for less volatile semi-bituminous and anthracite coals.

(2) The bed thickness for best results depends on many factors, including the kind, size and condition of coal, the characteristics of the ash, the draft available and the loading. In general, with natural draft, bed thicknesses range from four to eight inches with run-of-mine bituminous coal and with anthracite buckwheat. Bed thicknesses range from 10 to 14 inches for semibituminous coals. With heavy loading, however, it may be desirable to

use a relatively thin fuel bed to increase the flow of primary air obtainable with the available draft. In all

cases, bed thickness for a given type of furnace and coal is best determined by experiment.

### Section III. OIL BURNERS

#### 3-9. General.

Most modern oil fired furnaces and boilers used at Army installations have gun type burners. Horizontal rotary burners may be found on some older heating systems. These two types of burners will be discussed in this section.

#### 3-10. Burner descriptions.

*a. Gun type oil burners.* Gun type oil burners atomize the fuel either by oil pressure (high-pressure gun) or by low-pressure air (low-pressure gun).

(1) *High-pressure gun burners.* The oil system of a high-pressure atomizing burner consists of a strainer, pump, pressure-regulating valve, shut-off

valve, and atomizing nozzle. (See figure 3-4.) The air system consists of a power-driven fan with provision to throttle the air inlet, an air tube surrounding the nozzle and electrode assembly, and vanes or other means to induce turbulence for proper mixing of air and fuel oil. The fan and oil pump are generally directly connected to the motor. Atomizing nozzles are available for various spray patterns and oil rates to suit particular installations. Flame shapes vary depending upon the design of the air exit at the end of the air tube. Oil pressures are generally about 100 psi, but considerably greater pressures are sometimes used. Burner output ranges from 0.5 gph and higher.

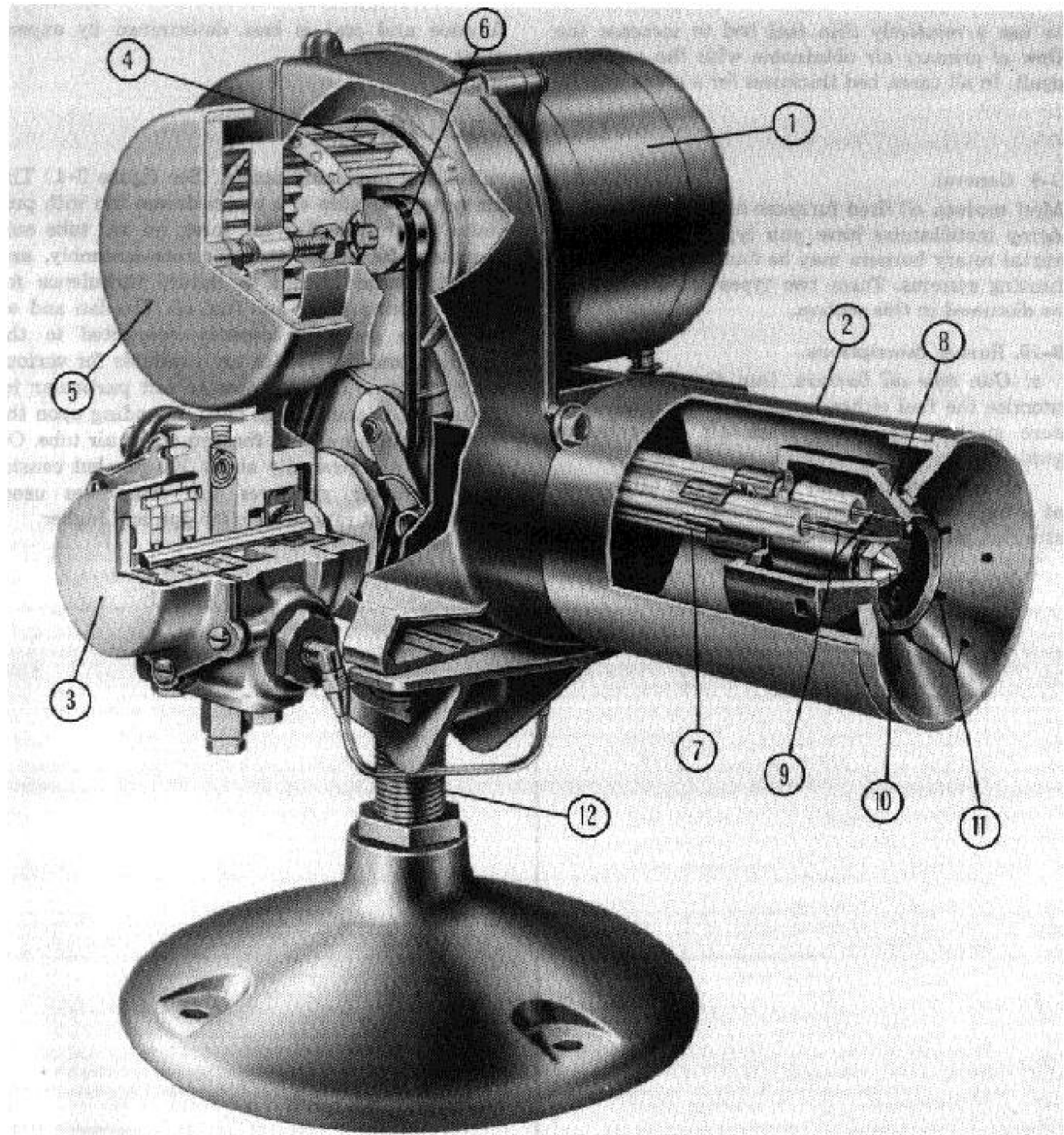

- |                          |                          |
|--------------------------|--------------------------|
| 1. MOTOR                 | 7. FUEL LINE TO NOZZLE   |
| 2. COMBUSTION HEAD       | 8. DEFLECTOR CONE        |
| 3. FUEL PUMP ASSEMBLY    | 9. ELECTRODES            |
| 4. BLOWER WHEEL          | 10. ATOMIZING NOZZLE     |
| 5. AIR INTAKE ADJUSTMENT | 11. COMBUSTION AIR HOLES |
| 6. V-BELT DRIVE          | 12. ADJUSTABLE LEG       |

Figure 3-4. Pressure atomizing gun type oil burner.

(2) *Low-pressure gun burners.* This gun type burner uses a portion of the combustion air at relatively low pressures to mix with the fuel oil at the nozzle orifice. Expansion of the compressed air froths or emulsifies the oil and a fine spray is delivered into the combustion chamber. The form and parts of the low pressure air-atomizing burner, as shown in figures 3-5 and 3-6 may be similar to those of the high-pressure atomizing burner except for the addition of a small air compressor and

means to deliver the air and oil to the nozzle. The oil pump delivers the fuel oil at low pressure. The nozzle opening is relatively large because of the low pressure and the increased volume of the air-oil mixture. Electric ignition is almost exclusively used. Electrodes are located near the nozzle, but out of the path of the oil spray. Minimum burner output is approximately 20 gph so that this type burner is used only for very large furnaces.

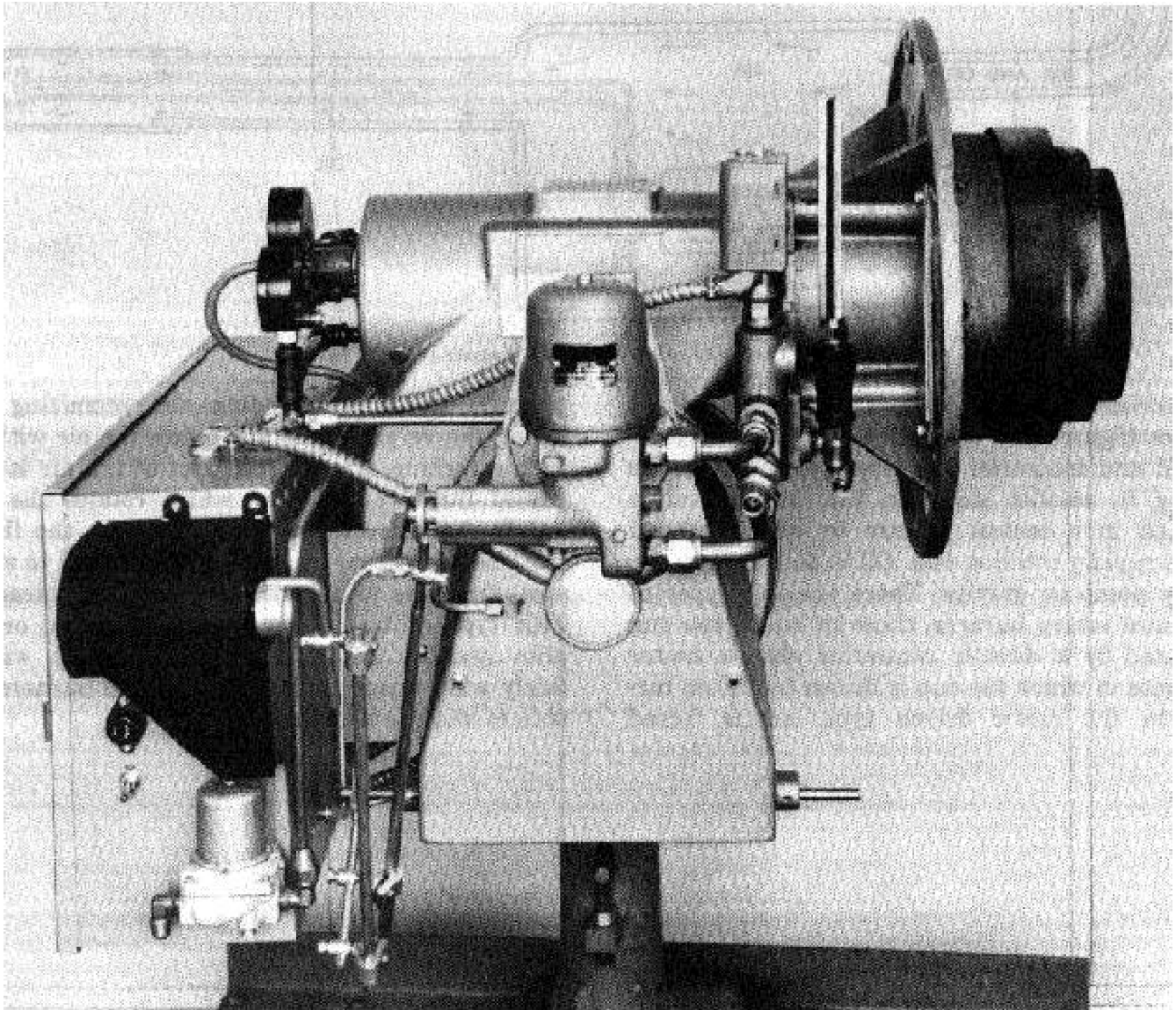

*Figure 3-5. Air atomizing gun type burner.*



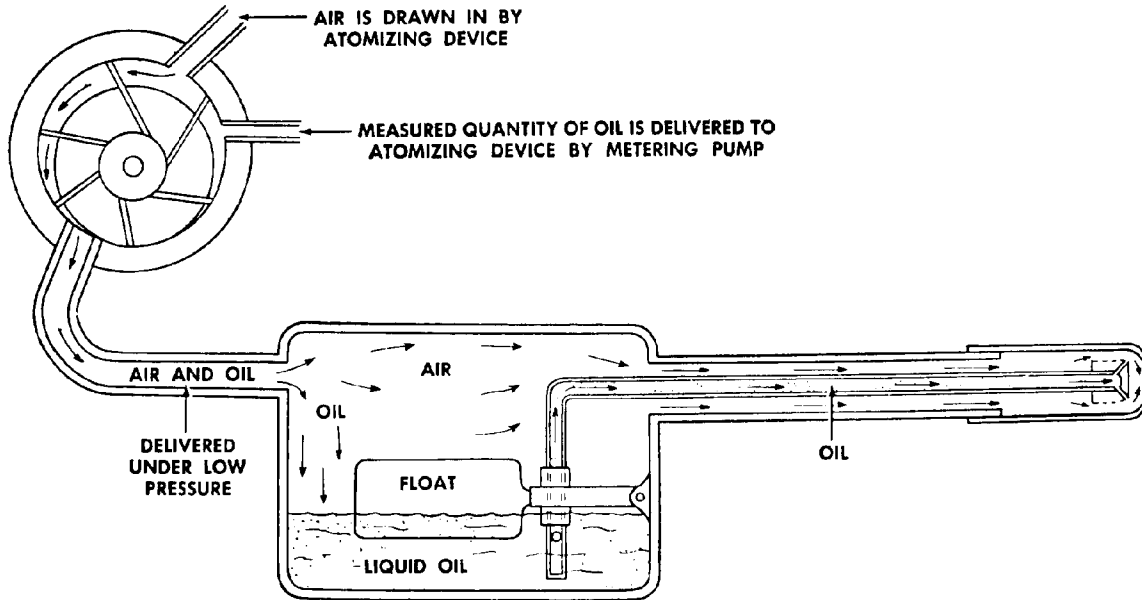

Figure 3-6. Operating principles of low pressure gun type burner.

b. *Horizontal rotary burners.* Horizontal rotary burners (figure 3-7) originally designed for commercial and industrial use, are used for domestic heating in smaller sizes. In this burner, oil is atomized in a conical pattern by being sprayed from a rapidly rotating cup. Oil is delivered to the cup by pump or gravity. There are two types of horizontal rotary burners, those in which the cup is rotated by a directly connected electric motor and those in which the cup is driven by an air turbine. In the motor driven type, air is forced through vanes

surrounding the atomizing cup which shapes the flame and mixes the air with oil. In the turbine driven type, part of the air is first passed through a turbine which rotates the cup, and is then directed to properly shape the flame. Horizontal rotary burners are constructed to swing away from the furnace for inspection and cleaning. This type of burner employs gas-electric or gas pilot ignition and operates satisfactorily with a fairly wide range of fuels. Large size burners are able to atomize heavier oils.

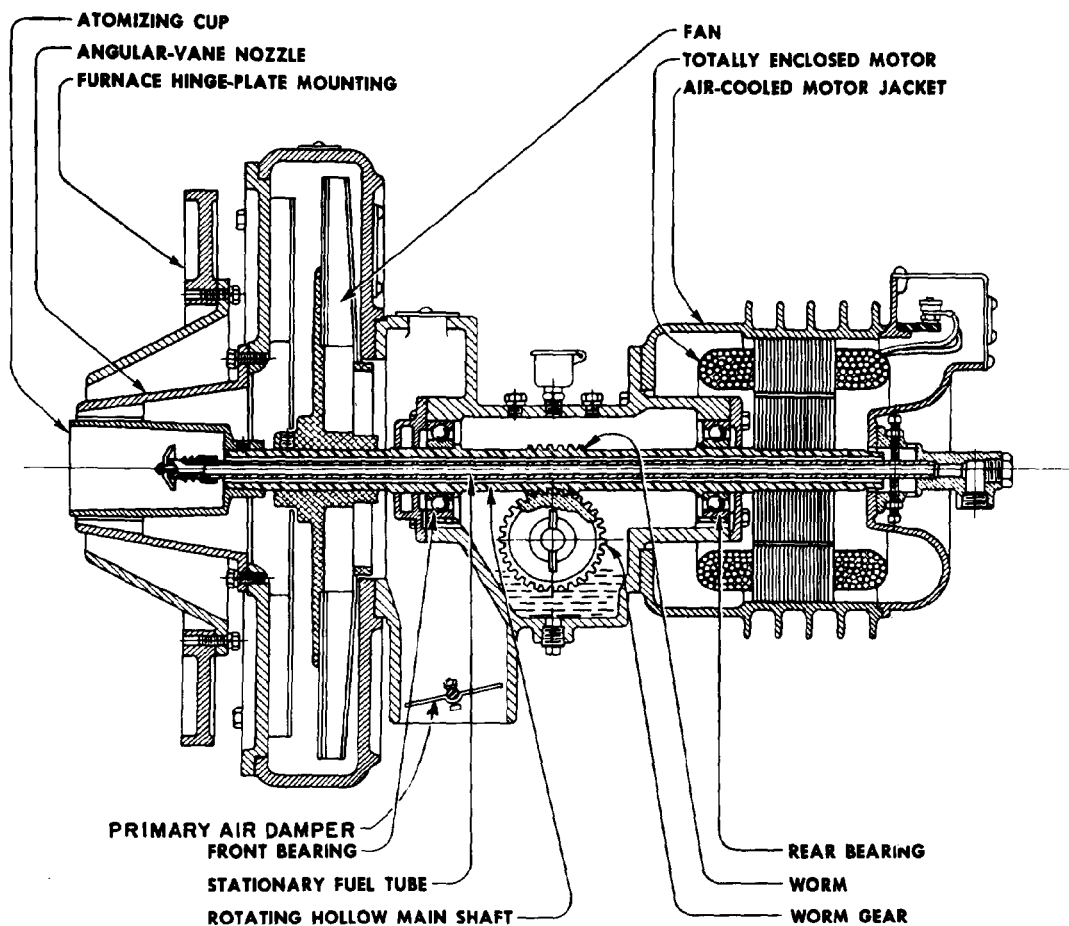

Figure 3-7. Horizontal rotary oil burner.

### 3-11. Ignition procedures.

Domestic oil burners vaporize and atomize the oil and deliver a predetermined quantity of oil and air to the combustion chamber for combustion. Oil burners for boilers and warm air furnaces operate automatically and maintain a desired temperature.

*a. Oil pressure.* Pressure must be sufficient to properly atomize the fuel oil and to provide flow of fuel to the atomizing head at a minimum velocity consistent with efficient operation. Generally, No. 1 oil will work well in small burners provided it contains a lubricant to lubricate the pump. A comparatively heavy oil will allow flow through a given nozzle somewhat in excess of the rating stamped on the nozzle. Heavy oils require 100 psi pressures. High pressure plus heavy oil tends to raise the flow rate considerably above the nozzle marking. If the flow is too heavy, a smaller nozzle should be installed.

*b. Burner starting* The following procedure should be followed to start a gun-type or horizontal rotary burner.

(1) Set draft for 0.02 to 0.04 inch water gauge.

(2) Partly close air shutter.

(3) Check pressure gauge and petcock installation.

(4) Make a cold contact in primary burner control or stack switch by tilting contact carrier to left so contact closes. See instructions from supplier of primary control for this operation.

(5) Close burner switch with thermostat and limit control calling for heat.

(6) Open petcock to expel air from system. Close when oil flow is clear.

(7) If burner stops before oil reaches nozzle, let safety element in stack control cool before pushing button to restart. Do not hold relay in because safety element will become overheated.

(8) Slowly open air adjustment until fire burns clean.

(9) If oil initially discharges into the firebox without igniting because of ignition difficulty or other cause, oil will soak into the soft brick. Be sure relief door is open. Properly ventilate combustion chamber after any misfire. When burner does ignite, shut burner off immediately and allow sur-

plus oil to burn off. Oil-soaked brick will cause the burner to rumble and puff for a few minutes until oil has completely burned out. After any misfire, personnel should stand to one side of the opened relief door to avoid injury from possible backfire.

(10) Make final air adjustment after burner has been running long enough to warm the fire-pot. Look through the barometric draft regulator with a droplight. Reduce the supply of burner air until smoke can be seen passing through the light ray in the smokepipe. Then open the air adjustment until smoke disappears.

(11) After the burner has been visually adjusted and allowed to run for approximately 30 minutes, reduce the stack draft until there is just enough pressure in the firebox to prevent possible increases under unfavorable draft conditions. The draft regulator helps maintain a constant draft regardless of outside weather conditions. Adjust the draft by properly setting the adjuster. Too little draft is likely to cause firebox pressure, odors in the building and possible smoke or smothering of the flame. Excessive draft accentuates the effect of a possible leak, lowers the percentage of CO<sub>2</sub> in the flue gas, and in turn reduces the overall efficiency of the unit. After burner flame and draft are properly adjusted, flue-gas analysis should show a CO<sub>2</sub> content of approximately 10 percent. If it does not, recheck the burner air adjustment and inspect for air leaks. For best results, the flame should be just large enough to heat the building properly in cold weather. Air supplied to the burner should be the minimum necessary for clean combustion.

### 3-12. Oil burner operation.

The rate of heat production required to maintain desired temperatures varies widely. Some means must therefore be provided to control the rate at which heat is produced. This control may be achieved manually or with automatic controls. There are three firing strategies used in the operation of oil burners.

*a. Intermittent.* In the intermittent system, the burner operates at a high set rate until the room temperature reaches the desired point. At this point, automatic controls cause the burner to suspend operation completely until lower room temperatures cause it to resume operation. Automatic ignition of the electric or pilot light type is essential to this system of operation.

*b. High-low.* In the high-low system, two rates of burning are provided, one below and the other in excess of average demand. When room temperatures fall below normal, the burner automatically

operates at high flame, and changes to low flame when room temperatures reach a desired point. A modification to this system provides for three ranges of firing.

*c. Continuous.* In the continuous system, the flame burns continuously but the rate is regulated manually or automatically to meet the heating load.

### 3-13. Inspection and maintenance of oil burners.

*a. Equipment.* Each serviceman should have the items listed below to start or to service gun-type and horizontal rotary burners.

(1) Pressure gauge set consisting of 150 psi pressure gauge, fittings and petcock for purging air from oil line when starting the burner. Pressure gauges with ranges as high as 600 psi may be required for high-pressure gun burners.

(2) A full set of Allen setscrew wrenches for the bypass plugs and for adjusting the nozzle holder and electrodes. Use only a socket wrench of proper size for the nozzle. An open end S-wrench is required for nozzle holders.

(3) Small screw driver for adjusting pressure at regulator and for installing and servicing the thermostat.

(4) Pipe dope for use with oil lines. Be sure that it is special oil pipe dope. Use this on all pipe threads.

(5) Complete assortment of nozzles. Nozzles should be replaced as required, rather than cleaned on the job. After a few nozzles are accumulated, they should be cleaned in the shop.

(6) Combustion analysis kit including draft gauge.

*b. Cleaning nozzles.* Clean nozzles only in the shop on a clean bench. A nozzle is a delicate device and should be handled with care. Use kerosene or safety solvent to cut grease and gum and use compressed air, if available to blow dirt out. Wear goggles to protect the eyes when using compressed air. Never use a metal needle to clean the orifice; sharpen the end of a match, or use a brush bristle for this purpose. Always use a socket wrench when turning the nozzle. Be sure that the nozzle seat is clean. When it comes to "bottom", back it off and retighten it several times to make a tight oil seal. Exercise care not to strip nozzle threads.

*c. Replacing nozzles.* Select replacement nozzles that have the same capacity and are for the same type oil as the nozzle to be replaced. Also, make certain that replacement nozzle has the same angle of spray and the same spray pattern as the nozzle being replaced. All nozzles are stamped to identify

their operating characteristics and capacity. If a nozzle is to be operated at a pressure different than that stamped on the nozzle, refer to table 3-1 to determine approximate oil flow (No. 2 oil) at the desired operating pressure.

Table 3-1. Nozzle Selection Chart for No. 2 Oil

Rating at 100 psi (gph)	Operating—Capacity—(gph)				
	Pressure (psi)				
	75	125	150	175	200
0.40		0.45	0.49	0.53	0.56
0.50		0.56	0.61	0.66	0.71
0.60		0.67	0.74	0.79	0.85
0.65		0.73	0.80	0.86	0.92
0.75		0.84	0.92	0.99	1.06
0.85		0.95	1.04	1.13	1.20
1.00	0.87	1.12	1.23	1.32	1.41
1.10	0.95	1.23	1.34	1.45	1.55
1.20	1.04	1.34	1.47	1.59	1.70
1.25	1.07	1.39	1.53	1.65	1.77
1.35	1.17	1.51	1.65	1.79	1.91
1.50	1.30	1.68	1.84	1.98	2.12
1.65	1.43	1.84	2.02	2.18	2.34
1.75	1.51	1.96	2.14	2.32	2.48
2.00	1.73	2.24	2.45	2.65	2.83
2.25	1.95	2.52	2.74	2.98	3.18
2.50	2.16	2.80	3.06	3.30	3.54
3.00	2.59	3.35	3.68	3.97	4.25
3.50	3.03	3.91	4.29	4.63	4.95
4.00	3.46	4.47	4.90	5.30	5.66
4.50	3.90	5.04	5.51	5.95	6.36
5.00	4.33	5.59	6.13	6.61	7.07
5.50	4.76	6.15	6.74	7.27	7.78
6.00	5.19	6.71	7.33	7.94	8.48
6.50	5.63	7.26	7.96	8.60	9.20
7.00	6.05	7.82	8.58	9.25	9.90
7.50	6.49	8.38	9.19	9.91	10.60

Table 3-1. Nozzle Selection Chart for No. 2 Oil—Continued

Rating at 100 psi (gph)	Operating—Capacity—(gph)				
	Pressure (psi)				
	75	125	150	175	200
8.00	6.93	8.94	9.79	10.58	11.31
9.00	7.79	10.06	11.02	11.91	12.73
10.00	8.66	11.18	12.25	13.23	14.14
20.00	17.32	22.36	24.49	26.46	28.28
30.00	26.00	33.60	36.80	39.70	42.50
40.00	34.60	44.70	49.00	53.00	56.50
50.00	43.30	55.90	61.30	66.10	70.70
60.00	52.00	67.00	73.50	79.40	84.00
70.00	60.60	78.20	85.70	92.50	99.00
80.00	69.20	89.40	98.00	106.00	113.50
90.00	77.90	100.90	110.50	119.20	127.50
100.00	86.50	111.90	122.50	132.30	141.40

d. *Troubleshooting.* Following is a description of possible problems and remedial steps that should be taken.

(1) Furnace pulsates on start, stop or during operation.

(a) Check all adjustments of the nozzle-electrode assembly and blast tube in relation to each other and to the firebox. The nozzle and electrode assembly includes oil pipe, nozzle holder, nozzle and strainer, electrodes, glazed porcelain insulators around electrodes, supporting clamp for all parts, and the static disc. The nozzle tip should be back **d** inch to **e** inch from the end of the tube. See figure 3-8. For average assembly, ignition points should be **c** inch apart, **c** inch ahead of nozzle, and ½ inch to **e** inch above the nozzle center line.

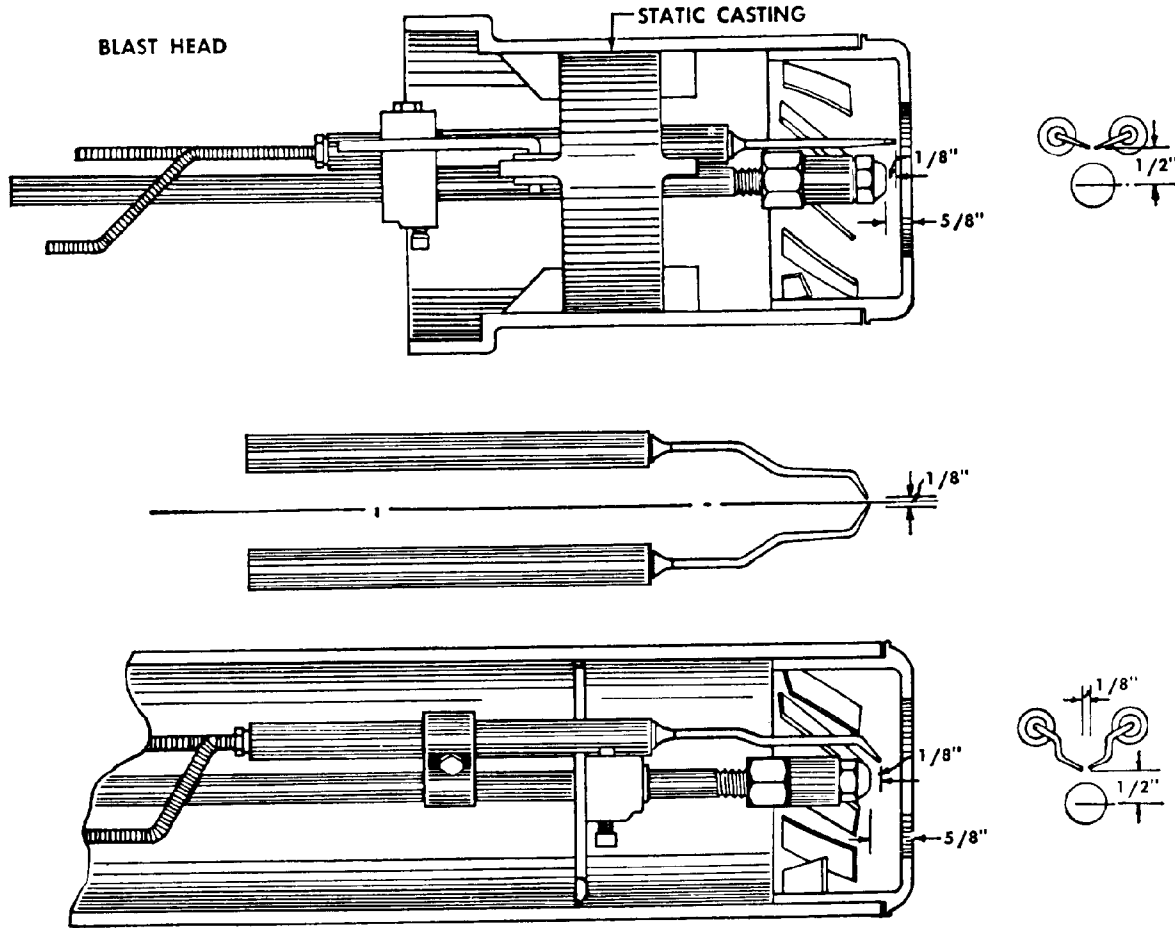

Figure 3-8. Settings of ignition points and nozzle for oil burner.

(b) Be sure that the draft is correct. Make sure that there is no downdraft. If draft is not strong enough, change the setting on draft regulator. Check the chimney to see that there are no leaks to cause poor draft.

(c) Nozzle may be defective. Replace nozzle with a new one.

(d) Be sure air is out of the line between fuel unit and nozzle. Air trapped here will compress during burner stops. This causes oil to squirt at the nozzle when the burner shuts down. Wait a few days after burner installation to make final adjustments. This often allows time for the trapped air to escape.

(2) Flame is raw and stringy.

(a) Be sure the air adjustment is not open too wide. Too much air will make a poor fire and cause surplus raw oil to soak into the fire brick.

(b) Nozzle may be partially plugged. Replace nozzle with a new one.

(c) Be sure that all air is out of the pump. If not, vent with petcock on pressure gauge.

(3) Ignition points collect carbon.

(a) If the nozzle is in good condition, check ignition points, and move them up slightly if they are in the spray. See figure 3-8.

(b) Be sure nozzle is tight in the holder. A leak here will allow oil to escape and carbonize on the electrodes.

(c) Check shutdown of the burner to be sure that the pressure regulating valve shuts off the oil completely.

(4) Noise in the oil pump.

(a) This is usually caused by air in oil lines, a plugged strainer or water condensed in the oil tank which creates excessive suction on the oil line. Purge air from the oil line by loosening the vent plug where the pressure gauge is attached.

(b) Check for leaks in the suction line. Any leaks in overhead piping, above the liquid level in the storage tank, will allow air to enter the oil line.

(c) Clean the strainer in the pump, change the oil line filter.

(d) With some very light oils, an overhead pipe will allow air in the oil to settle out and collect in bubbles. Air can then come through, and obstruct pump action. Two-pipe fuel line systems minimize such danger.

(5) Frequent burner cycling.

(a) Be sure that the heating element in the room thermostat is screwed in tightly. Check wiring; wires may be reversed or spliced incorrectly. The wires may also be reversed at the primary burner control.

(b) Check thermostat adjustment. See manufacturer's instructions packed with thermostat.

(c) Check drive arm adjustment of the primary burner control. See instructions packed with the primary burner control.

(d) Check limit control. If set too low, the burner will shut down before the building can get warm. Filters above blower may be plugged so that there is insufficient air circulation. This will cause the burner to shut down on limit control.

(e) The nozzle may be too large for the unit so that heat buildup is too rapid.

(6) Primary control or stack switch throws burner into safety shutdown.

(a) A low voltage condition may have occurred. Check with a recording voltmeter for at least 24 hours, preferably longer.

(b) Check polarity of wiring. If connections are reversed or the hot line is where the ground should be, there is sometimes enough leakage through the control to cause a safety shut-down.

(c) See manufacturer's instructions with the primary burner control to insure that all adjustments within this control are correct.

(7) No oil appears at the nozzle.

(a) Fuel is too low in supply tank.

(b) Nozzle is plugged.

(c) Look for a leak in the suction line.

(d) Look for a leak in the vacuum gauge port.

(e) See that the pump shaft rotates.

(f) Look for a leak around the strainer gasket.

(g) Inspect for leaks at the pump shaft seal.

(h) If the preceding steps do not locate the problem, loosen the vent plug in the fuel unit

(pump) and run the burner to see if fuel flows as far as the fuel unit. If fuel reaches the fuel unit the problem is within the fuel unit.

(I) If trouble is isolated to the fuel unit, it should be returned for repair.

*e. Coupling adjustment.* When installing the coupling between the pump and motor, check to see that there is no undue pressure on the pump shaft. If pressure exists, locate the coupling closer to the body of the fuel unit shaft.

*f. Burner adjustment.* An oil burner must deliver sufficient heat to provide for winter heating requirements, plus an amount sufficient to warm up a cold building in a reasonable period of time. If the oil burner is adjusted to provide a greater amount of heat than is necessary, the boiler or furnace will operate at a higher rate with consequent lower efficiency. After adjusting the oil rate to the heat requirement, regulate the draft and air quantity. An automatic draft regulator is necessary for proper burner operation. The lower the draft, the smaller the amount of air that will flow through the furnace or boiler when the burner is down. However, starting conditions require a draft in the firebox of about 0.03 to 0.06 inches water gauge. If it is impossible to obtain sufficient air for proper combustion with this draft, the draft in the firebox must be raised. After preliminary draft adjustment, adjust the quantity of combustion air to give the flame appearance and CO<sub>2</sub> recommended by the burner manufacturer. Use a flue gas analyzer to determine the carbon dioxide (CO<sub>2</sub>) and a draft gauge for measuring the draft. It may be necessary to readjust the draft as a change in air supply affects the draft and vice versa. Carefully obtain a fair sample of flue gas for analysis as a leaky boiler or furnace setting may give a false indication of air used for combustion. The resulting flame should be clean and free from smoke. When the correct setting is determined, lock the adjustment points for air, oil, and draft to prevent change. When the burner has been adjusted, test all safety controls in accordance with the manufacturer's instructions.

### 3-14. Fuel oil piping.

Figure 3-9 shows a typical arrangement of piping from the fuel oil tank to the oil burner.

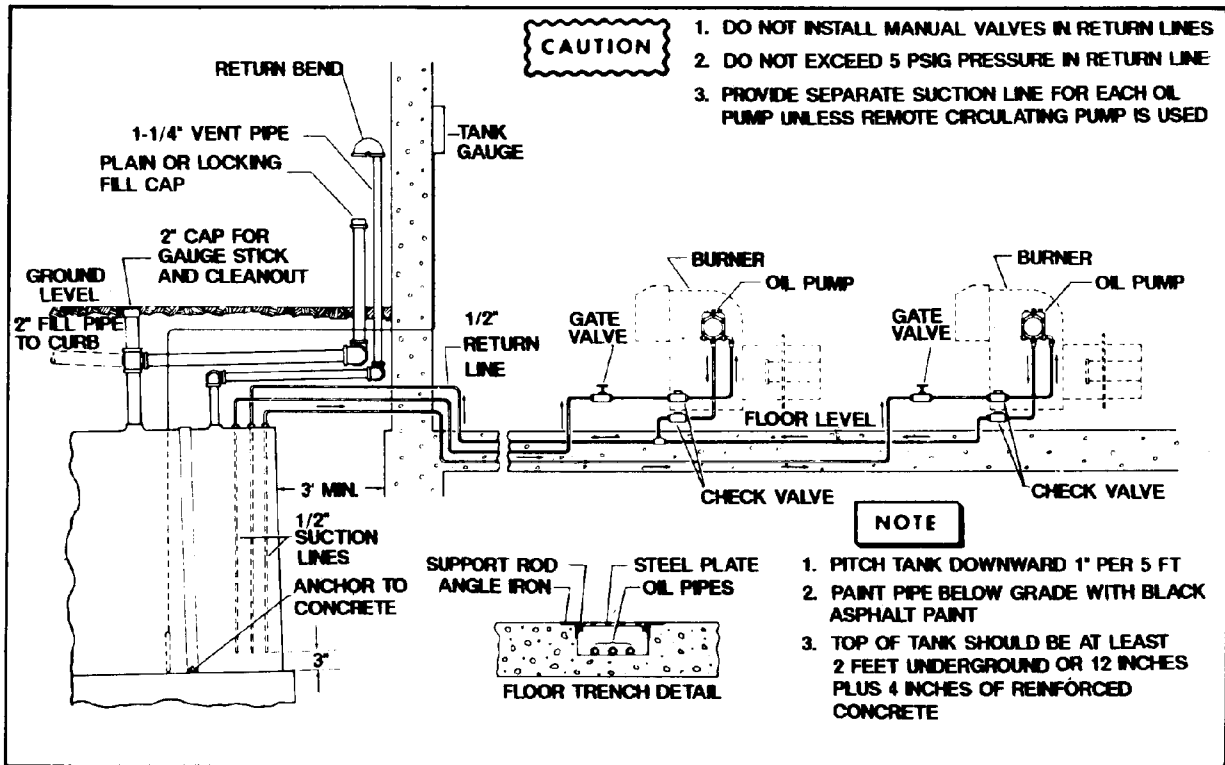

Figure 3-9. Typical fuel oil piping.

a. *Automatic oil shut-off* A thermomechanically or thermoelectrically actuated shut-off valve is provided in the oil supply line to stop oil flow in the event of a fire at the oil burner. The thermal detection device for the valve should be located directly above the oil burner. Figure 3-10 shows a

lever gate valve designed for installation in connection with a wire and fusible link. When the fusible link releases at approximately 165F, the springloaded lever closes the valve, stopping oil flow to the burner.

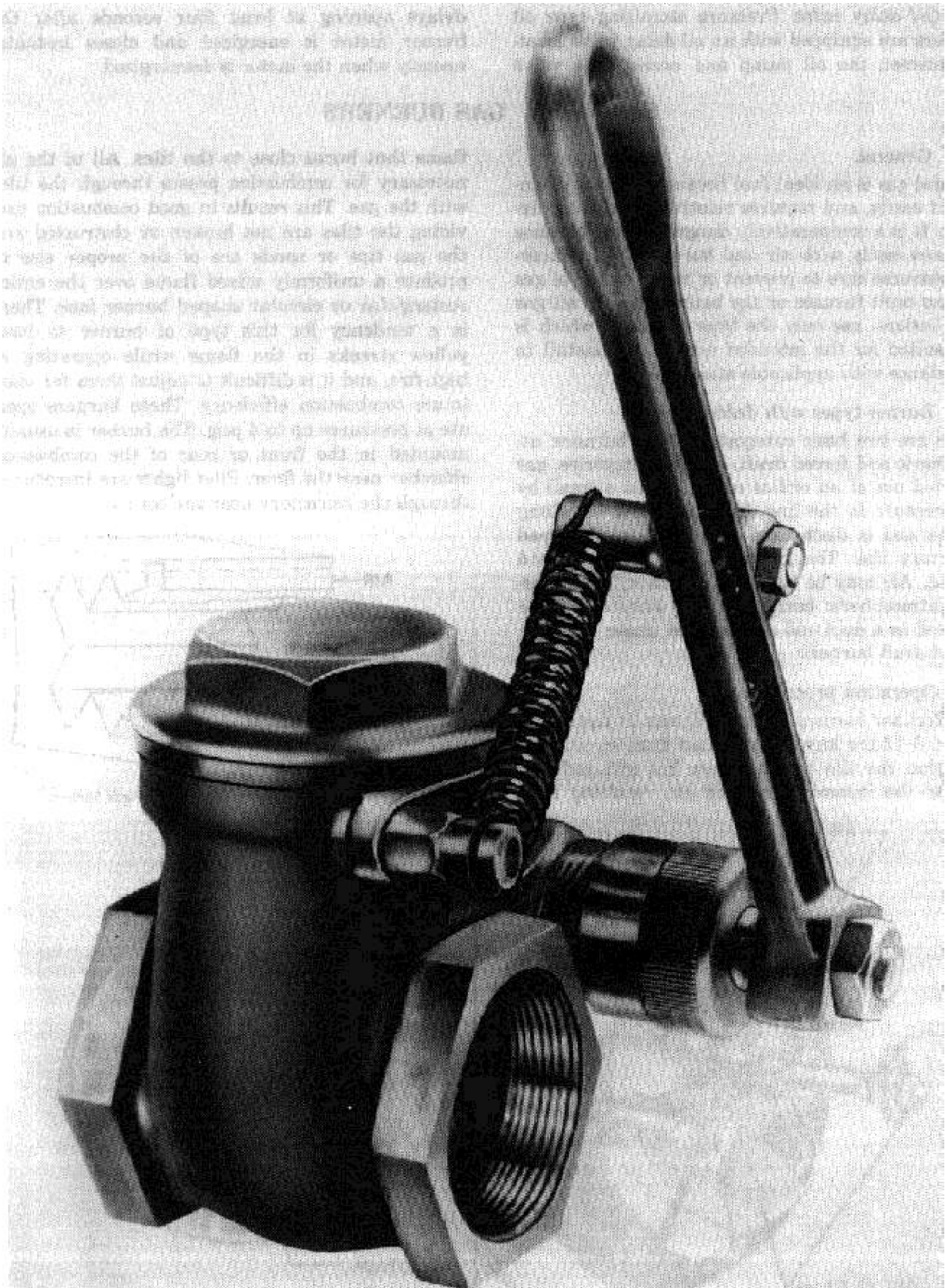

Figure 3-10. Automatic oil shut-off valve.



b. *Oil delay valve.* Pressure atomizing type oil burners are equipped with an oil delay valve located between the oil pump and nozzle. The valve delays

opening at least four seconds after the burner motor is energized and closes instantaneously when the motor is deenergized.

**Section IV. GAS BURNERS**

**3-15. General.**

Natural gas is an ideal fuel because it burns cleanly and easily, and requires relatively simple equipment. It is a comparatively dangerous fuel because it mixes easily with air and burns readily. Exercise extreme care to prevent or stop leakage of gas into an unlit furnace or the boiler room. In all gas installations, use only the type of burner which is best suited for the intended service and install in accordance with applicable standards.

**3-16. Burner types with descriptions.**

There are two basic categories of gas burners: atmospheric and forced draft. In both categories, gas is forced out of an orifice or tip (called a spud) by gas pressure in the line. The gas draws air along with it and is discharged into a specially shaped refractory tile. The gas and air are mixed and burned. Air may be supplied at atmospheric pressure (atmospheric burner), or the burner may be enclosed in a duct and air supplied under pressure (forced draft burner).

**3-17. Operation procedures.**

a. *Radiant burners.* Burners shown in figures 3-11 and 3-12 are known as radiant burners since in operation the tile becomes very hot and radiates

heat to the incoming gas and air, resulting in a flame that burns close to the tiles. All of the air necessary for combustion passes through the tiles with the gas. This results in good combustion providing the tiles are not broken or obstructed and the gas tips or spuds are of the proper size to produce a uniformly mixed flame over the entire rectangular or circular shaped burner face. There is a tendency for this type of burner to have yellow streaks in the flame while operating at high-fire, and it is difficult to adjust them for maximum combustion efficiency. These burners operate at pressures up to 4 psig. The burner is usually mounted in the front or rear of the combustion chamber near the floor. Pilot lights are introduced through the refractory near the center.

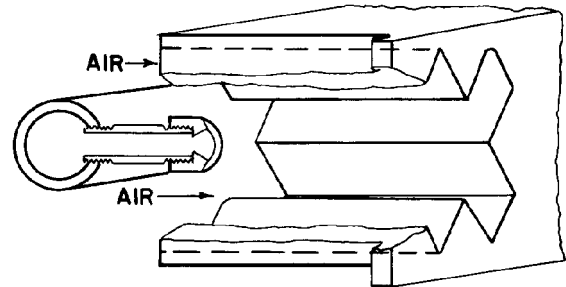

Figure 3-11. Individual low pressure gas burner.

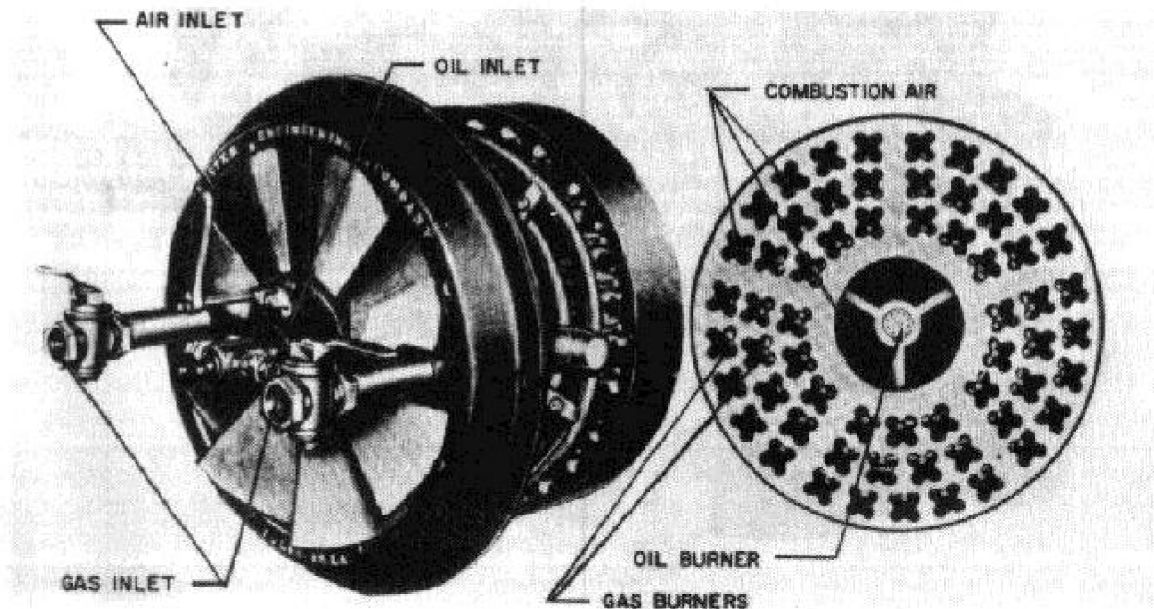

Figure 3-12. Assembly of low pressure gas/oil burner.

b. *Up-shot burners.* This type of gas burner uses a special venturi shaped tube casting mounted on the spud which projects up into the venturi. The top is enlarged to hold a standard 2¼ x 4½ x 9 inch firebrick. Air is drawn into the bottom of the venturi and mixed with gas. The mixture of gas and air strikes the bottom of the brick after passing through a small baffle which improves the distribution of the mixture, and escapes around the

sides and edges of the brick. Two types of venturi tubes are in general use. In one, the brick is installed flat; in the other, the brick is supported on one of the long faces. A complete burner is made up of a number of these venturi units, arranged as shown in figure 3-13. The number used depends on the capacity of the boiler or size of the furnace. These burners operate at pressure up to 4 psig.

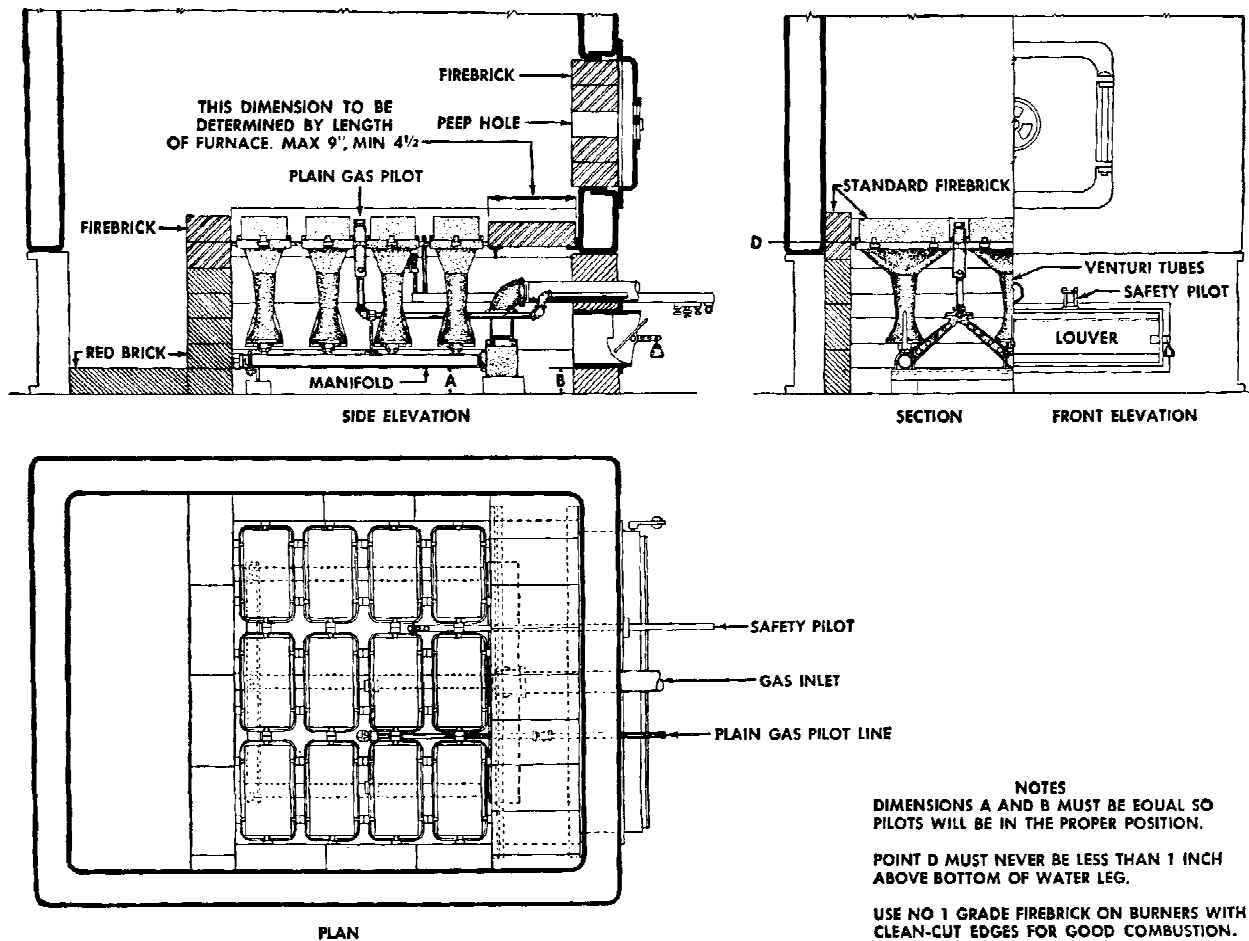

Figure 3-13. Typical installation of low pressure gas burner.

c. *Mechanical mixing burners.* This type of burner is extremely limited in use, but it does have the advantage of creating an intimate mixture of gas and air which permits operating through a wide range with a transparent flame without yellow streamers. The burner consists of a spider with the gas issuing from tangentially mounted orifices. The reaction from the expanding gas at these orifices causes the spider to rotate. The spider is mounted on a shaft which drives a combustion air blower. The spinning orifices on the spider create the effect of an infinite number of orifices, resulting in good,

mechanical mixing of the air and gas. The characteristics of the driven fan are such that it delivers air through the burner throat in direct proportion to the amount of gas being used. The combustion controls on the gas supply must be gradual in response. Since the blower fan would not slow down immediately on a sudden drop in the gas supply, a temporary lean mixture would result and the flame would move out from the throat into the furnace. These burners operate at pressures from 1 to 30 psig.

d. *Register burners.* A register or multispud gas burner is most suitable when burning gas in combination with oil. The gas burner does not interfere with the oil burner, making it possible to burn gas or oil independently or at the same time. The burner consists of a circular gas ring or manifold, with numerous holes drilled on the furnace side. Gas from these holes mixes with incoming air at the throat of the burner. At light loads, the flame burns close in the throat of the burner. At high rates of firing however, there is a tendency for the gas to burn farther away from the throat, with the possibility of the flame blowing out entirely on sudden load fluctuations and improper draft regulation. Burners of this type vary in amount of gas pressure required, depending on the size of the drilled holes in the gas manifold; but generally a minimum gas pressure of 1 psig is required for good operation. See figures 3-14, 3-15, and 3-16.

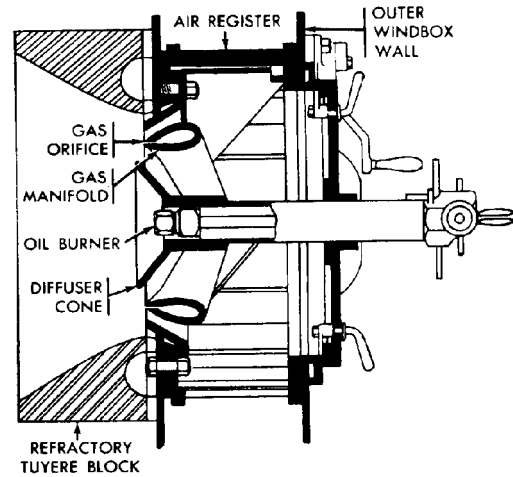

Figure 3-15. Register burner (gas manifold dividing air stream).

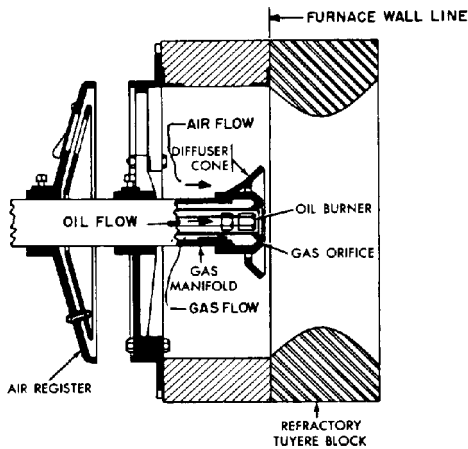

Figure 3-14. Register burner (gas orifices centered in air stream).

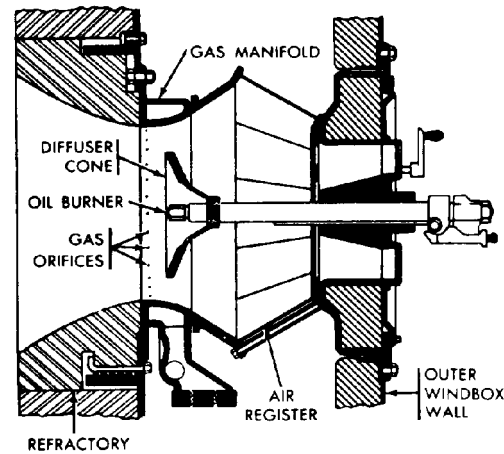

Figure 3-16. Register burner (gas orifices outside air stream).

### 3-18. Starting procedures.

The operation of gas burning equipment is simple, since the fuel is a gas which mixes intimately with air for combustion. Operation, however, can be hazardous, and the application of safety precautions cannot be overemphasized. The procedures given below must be followed in starting any gas fired equipment.

a. Make sure that the room in which the equipment is installed is free of gas which might have accumulated through leakage, accidental opening of a fuel valve, or failure of the pilot. Odorized gases may be detected by smell. Explosion meters can be used to detect the presence of gas in hazardous mixtures.

*b.* Inspect gas piping, valves, and controls to make sure that they are in good condition and in good working order.

*c.* Purge furnace by turning on the fan on forced draft burners. If natural draft, check flow of air and presence of any obstructions in flue and chimney passages.

*d.* Ignite burner as recommended by the manufacturer of the equipment.

### **3-19. Inspection and maintenance.**

Safety is the principal consideration. Prevent leakage at all times; locate piping, valves, and controls to prevent damage or breakage. Figure 3-17 shows three typical fuel gas system schematics as ap-

proved by Factory Mutual System (FM), Factory Insurance Association (FIA), and Underwriters Laboratories, Inc. (UL). Provide adequate ventilation for removal of products of combustion. Inspect flues and chimneys for deterioration due to high moisture content of burned hydrogen. Chimneys should be moisture-proofed and smoke pipes replaced as required. Burning certain types of gases causes deposits in the burners and requires periodic burner cleaning. Refractories used in radiant type burners require routine inspection and periodic replacement. Consult manufacturer's manuals for specific operating instructions for the particular equipment used.

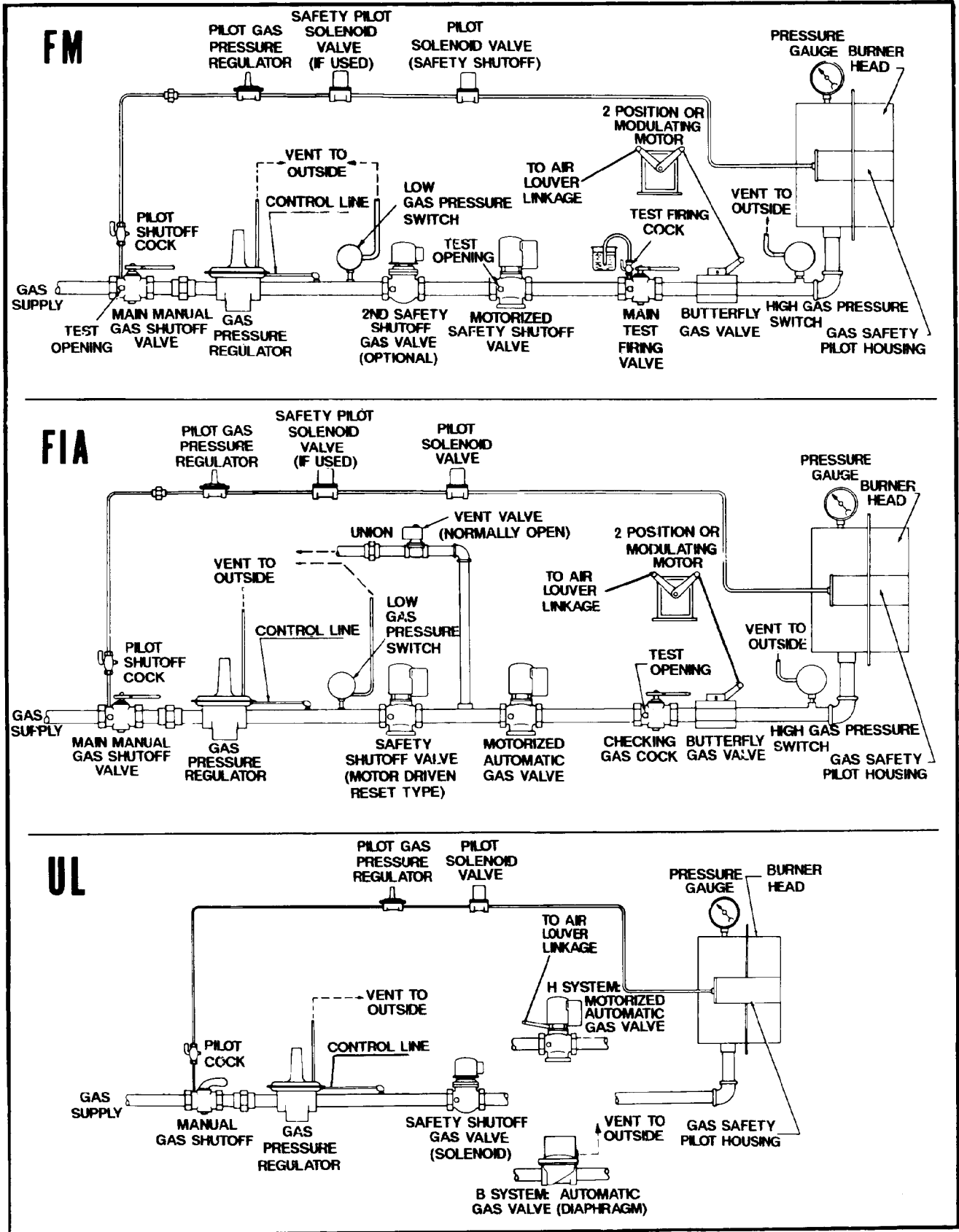

Figure 3-17. Typical fuel gas piping.

*a. Flame.* Inspect the burner periodically and note the appearance of the flame and gas pressures. A yellow flame indicates partially restricted air passages and the formation of carbon because of incomplete combustion.

*b. Combustion chamber.* Inspect the combustion chamber for evidence of burning papers and trash. Check the area directly in front of the burners for accumulated debris. Remove bricks and debris which affect the flame.

## Section V. DUAL FUEL (OIL/GAS) BURNERS

### 3-20. General.

Since oil is required for standby service in most localities where gas burners are installed, it has been the practice to install oil burners to supplement the gas burners. Steam or air pressure atomizing oil burners are usually used with radiant gas burners. The application of a suitable oil burner to a multijet upshot gas burner is more difficult because the oil burner must be installed independently. Ring type gas burners readily lend themselves for use in combination with oil. Mechanical mixing burners are also manufactured with steam atomizing oil burners, using steam for the reaction in the absence of gas.

### 3-21. Operation.

The nozzle-mixing type burners, where air and gas flow separately and mix just before entering the

furnace, are widely used as combination burners. The incoming air stream is usually supplied by a forced draft fan. Total air flow is controlled by duct dampers or fan speed. Burner air registers are used to control flame shape and are not intended to regulate air flow rate. Individual burner gas valves should be wide open when using gas as the fuel. Gas flow quantity and pressure should be controlled by a control valve at the header inlet.

### 3-22. Inspection and maintenance.

Inspection and maintenance procedures are identical to those described for individual oil burners and individual gas burners in this chapter.

## Section VI. ENERGY CONSERVATION

### 3-23. Adjustments to excess air.

*a. General.* In theory, combustion of oil, gas, or coal requires a given fuel/air ratio for complete burning and maximum efficiency. In practice, air is used to provide the necessary oxygen for combustion and must be supplied in excess of theoretical requirements to ensure complete combustion. The minimum quantity of air that will provide complete combustion is the optimum amount. Too little air prevents complete combustion and wastes fuel. Too much air reduces the rate of heat transfer to the boiler and furnace, and consequently increases the amount of heat lost out of the stack. It

is important, therefore, that airflow into the combustion chamber be controlled to achieve the most favorable fuel/air ratio for any given firing rate. The burner/furnace efficiency nomograph, figure 3-18 correlates stack temperature, stack gas analysis, and boiler or furnace efficiency for natural gas and No's 2 and 6 oil. Maximum efficiency occurs where %CO and %O<sub>2</sub> are at a minimum and %CO<sub>2</sub> is at a maximum. As demonstrated by figure 3-18, this occurs with 0% excess air. Some minimum quantity of excess combustion air is required, however, to assure complete combustion despite incomplete fuel and air mixing and load or draft instabilities.

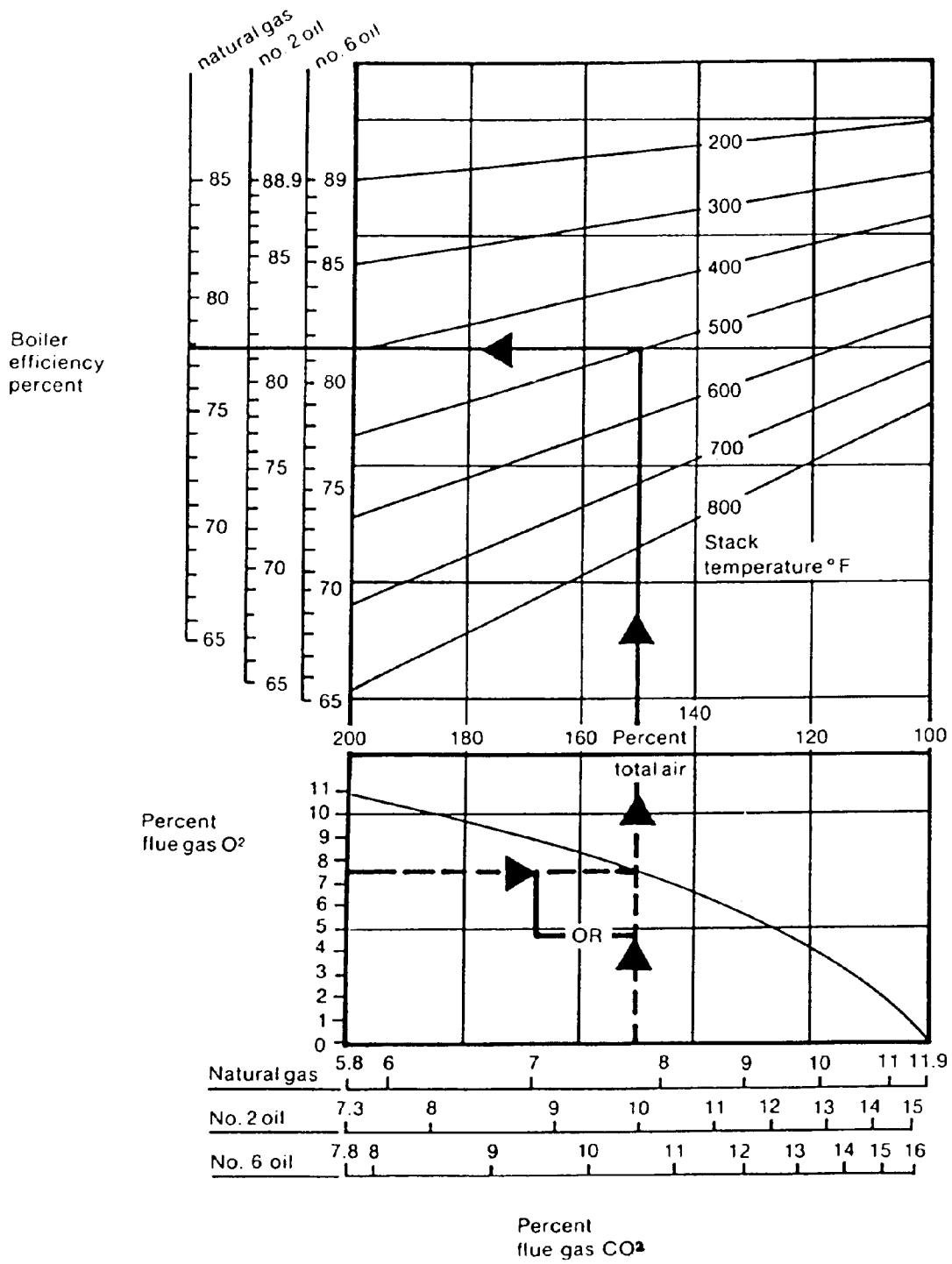

Figure 3-18. Combustion efficiency chart.

*b. Stack gas analysis.*

(1) Taken together, the percentage of carbon dioxide (CO<sub>2</sub>) or oxygen (O<sub>2</sub>) contained in the stack gas and the stack gas temperature determine the combustion efficiency, as shown in figure 3-18. Use a combustion analyzer to check the CO<sub>2</sub> content of the flue gas and a thermometer to check the flue gas temperature. Both stack temperature and stack gas analysis should be taken at the same point (preferably at a point just after the last heat recovery device) to minimize errors due to stack gas cooling and air infiltration.

(2) A more accurate measure of combustion efficiency is obtained by an analysis of the oxygen content (%O<sub>2</sub>) rather than the content of other gases such as carbon monoxide (CO) or carbon dioxide (CO<sub>2</sub>). As shown in figure 3-18, the cross-checking of oxygen concentrations is useful in judging burner performance more precisely. Furthermore, due to the increasing use of multifuel boilers, O<sub>2</sub> analysis is the single most useful criterion for all fuels since the O<sub>2</sub> to total air ratio varies only within narrow limits.

(3) Clean and monitor burners each year to assure optimum efficiency. Adjust burners when-

ever necessary. In large installations, make combustion monitoring and control a daily procedure.

*c. Tune-up and manual control.*

(1) Boilers and furnaces may achieve relatively high instantaneous full-load efficiencies (80%-90%), but because they are operated most of the time at part load, they have lower seasonal efficiencies. Generally, measures which increase the full load instantaneous efficiency will also increase the seasonal efficiency. When peak loads are of very short duration, however, it may be advantageous to tune the boiler for maximum efficiency at part load conditions in order to gain greater seasonal efficiency.

(2) Figure 3-19 depicts a typical part load ratio versus time curve for a boiler or furnace installation. In this example, the heating system operates between 50% and 60% of full load for more hours per year than at higher or lower loads. The optimum operating point of the heating system should be selected accordingly to give the highest efficiencies over this range. Examine previous load records to determine the optimum operating points to use when tuning an existing heating system.

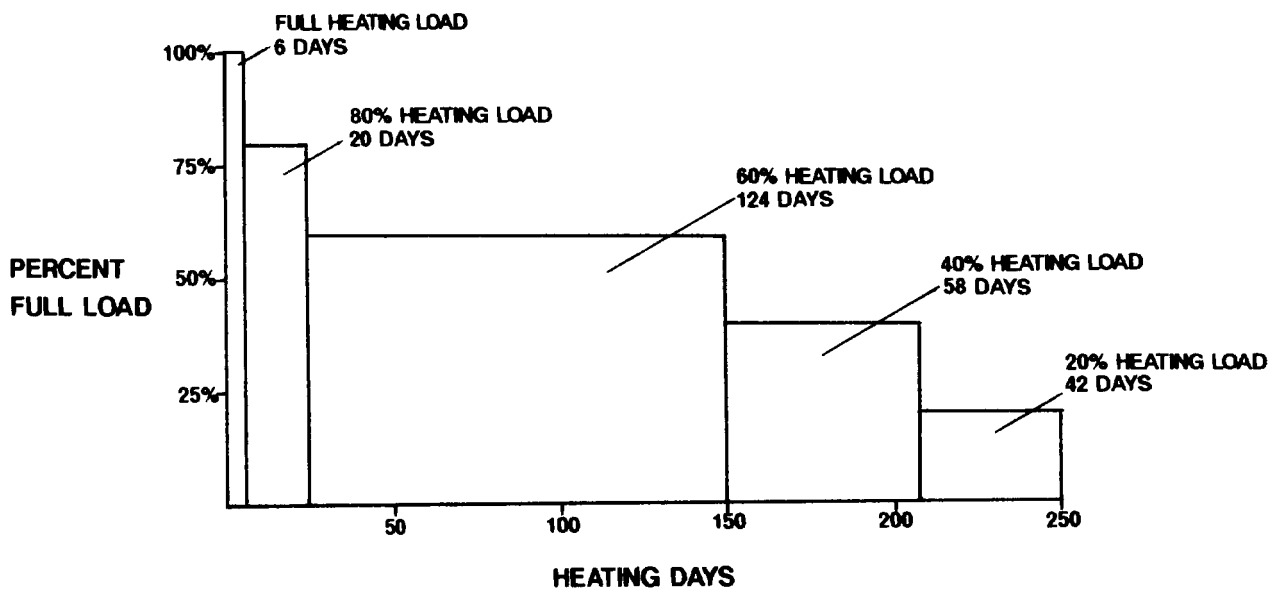

Figure 3-19. Typical heat load distribution.

(3) Devices are available which continuously measure and integrate CO<sub>2</sub> or O<sub>2</sub> concentration and stack temperature to produce a direct reading of boiler efficiency. These indicators provide boiler operators with the requisite information for manual adjustment of the boiler fuel/air ratio.

*d. Automatic control.* Optimum combustion efficiency, which varies continuously with changing

loads and stack draft, can be achieved only through a continuous analysis of the flue gas. The information required for continuous monitoring and adjustment of the fuel/air ratio is flue gas temperature and %O<sub>2</sub> or %CO<sub>2</sub>. For larger boilers, consider the installation of an automatic continuous oxygen analyzer with "trim" output that will adjust the fuel/air ratio to meet changing stack draft and



load conditions. Most boilers can be modified to accept automatic fuel/air mixture control by flue gas analyzer, but a gas analyzer manufacturer should be consulted for each particular installation to be certain that existing boiler controls are compatible with the proposed analyzer.

*e.* Burner retrofit. With the advent of more costly oil, many burners are being retrofitted to achieve better atomization and mixing of air and fuel. This allows more complete combustion, less soot and smoke, less cleaning, and better combustion efficiency. Oil burners that cannot achieve O<sub>2</sub> readings down to 5% excess without causing smoke (or high CO in the case of gas burners) are

candidates for replacement. Modern replacement burners are capable of more efficient atomization of oil or mixing of gas with combustion air.

*f.* *Reduce leakage.* Primary and secondary air should be allowed to enter the combustion chamber only in regulated quantities and only at the correct location. Defective gaskets, cracked brickwork, broken casings, etc. will allow uncontrolled and varying quantities of air to enter the boiler and will prevent accurate fuel/air ratio adjustment. If spurious stack temperature and/or oxygen content readings are obtained, inspect the boiler for air leaks and repair all defects before making a final adjustment of the fuel/air ratio.

## CHAPTER 4

### STEAM HEATING SYSTEMS

---

#### 4-1. General.

A steam heating system consists of the following elements: a steam source; supply piping to carry the steam from the source to the heating equipment; heating equipment, such as radiators located in areas to be heated; and return piping to carry the condensate from the heating equipment back to the steam source. Steam heating systems are classified according to piping arrangement and method of returning the condensate to the boiler. The successful operation of a steam heating system

requires the generation of steam at maximum efficiency and in sufficient quantity to equalize building heat losses, proper delivery of the steam to the heating terminal, expelling entrapped air, and returning all condensate, to the boiler rapidly. Steam cannot enter a space filled with air or water at a pressure equal to the steam pressure. Therefore, it is important to eliminate air and to remove water from the distribution system. All hot pipe lines exposed to contact by personnel must be properly insulated or guarded.

#### Section I. DESCRIPTION OF SYSTEMS

#### 4-2. General.

Steam heating systems are classified according to the method of returning the condensate to the boiler, whether by gravity or by mechanical means. In the gravity system, the condensate is returned because of a static head of water in the return pipes. In this type of system all radiation must be above the boiler water line. In the mechanical system, the condensate flows by gravity to a receiver and is then forced into the boiler under pressure. The main difference between the mechanical and the gravity systems is that radiation in the mechanical system can be located below the boiler water line as long as there is a low spot to which the condensate can be drained and from which it can be pumped to the boiler, feed water heater, or surge tank.

#### 4-3. Gravity one-pipe air vent system.

The gravity one-pipe air vent system was one of the earliest types in use. Because the condensate is returned to the boiler by gravity, this system is usually confined to a single building. Steam is supplied by the boiler and is distributed through a single piping system to radiators as shown in figure 4-1. Return of the condensate is dependent on the hydrostatic head. Radiators are equipped with an inlet valve and an air valve. The air valve permits venting of air from the radiators and displacement by steam. Condensate is drained from the radiators through the same pipe which supplies steam.

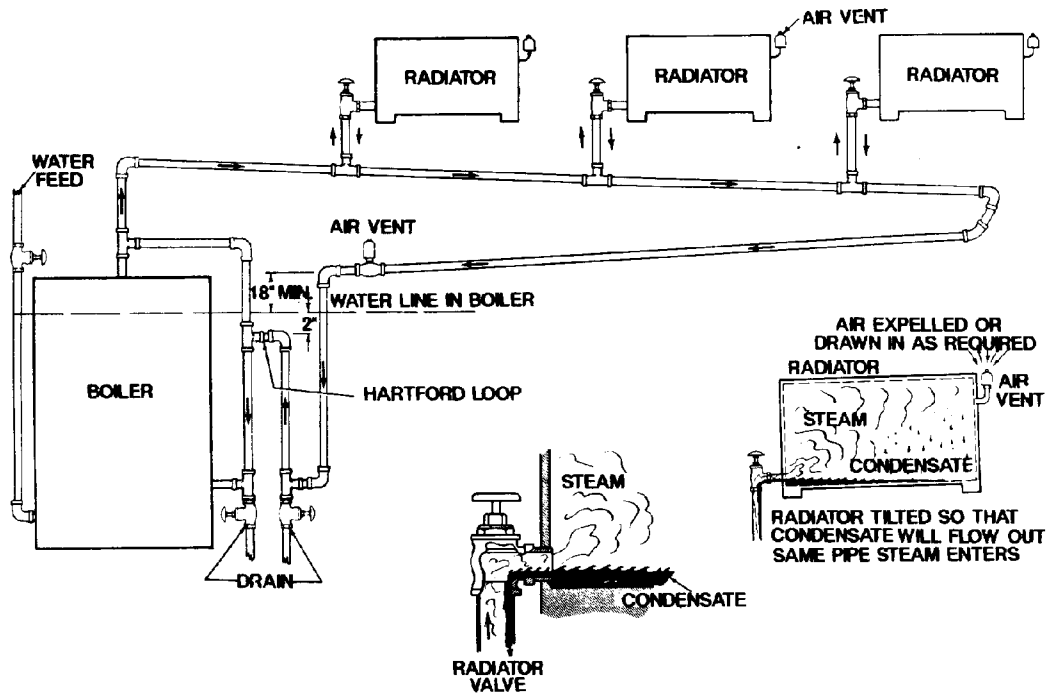

Figure 4-1. Gravity one-pipe vent system.

a. *Controls.* Appropriate controls for this system include a barometric draft control for boiler pressure control, or a pressure stat which controls a motor which operates the damper. Direct control of steam flow by use of mechanically operated steam valves is generally avoided due to difficulties in removing condensate after shut-off, and also due to the usual fluctuating steam pressure and flow characteristics of the gravity system. The gravity distribution system includes the boiler, radiators, piping, angle radiator valves of the on-off type as shown in figure 4-2, automatic air vent as shown in figure 4-3, and a barometric draft control as shown in figure 4-4.

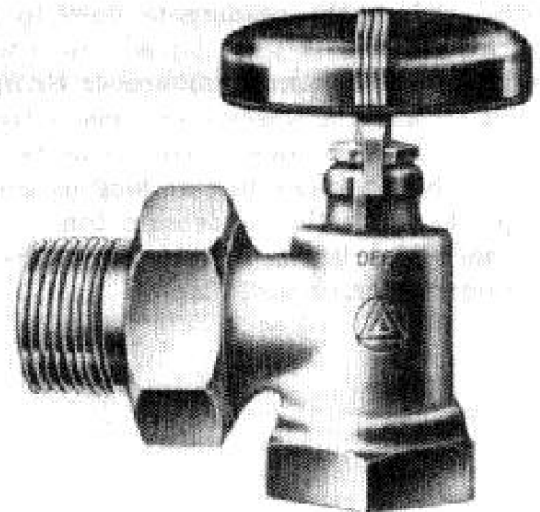

Figure 4-2. Angle radiator valve.

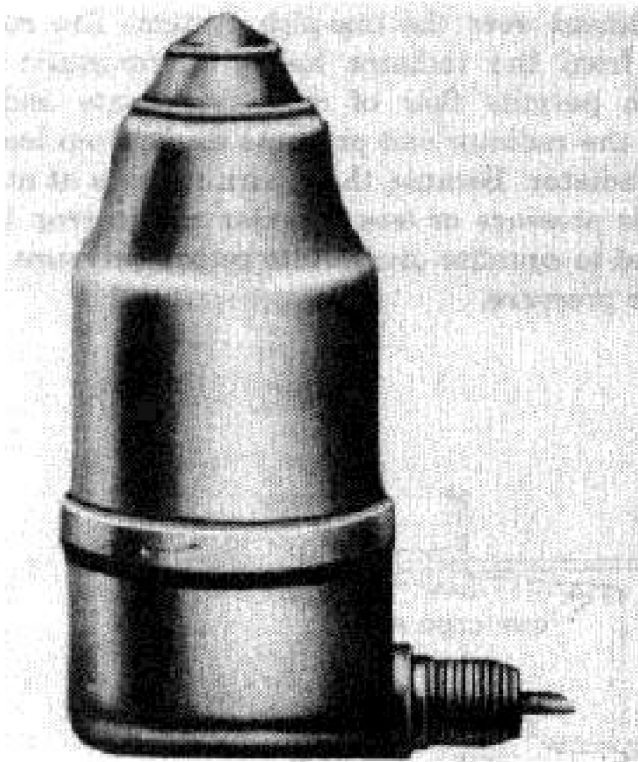

Figure 4-3. Automatic air vent.

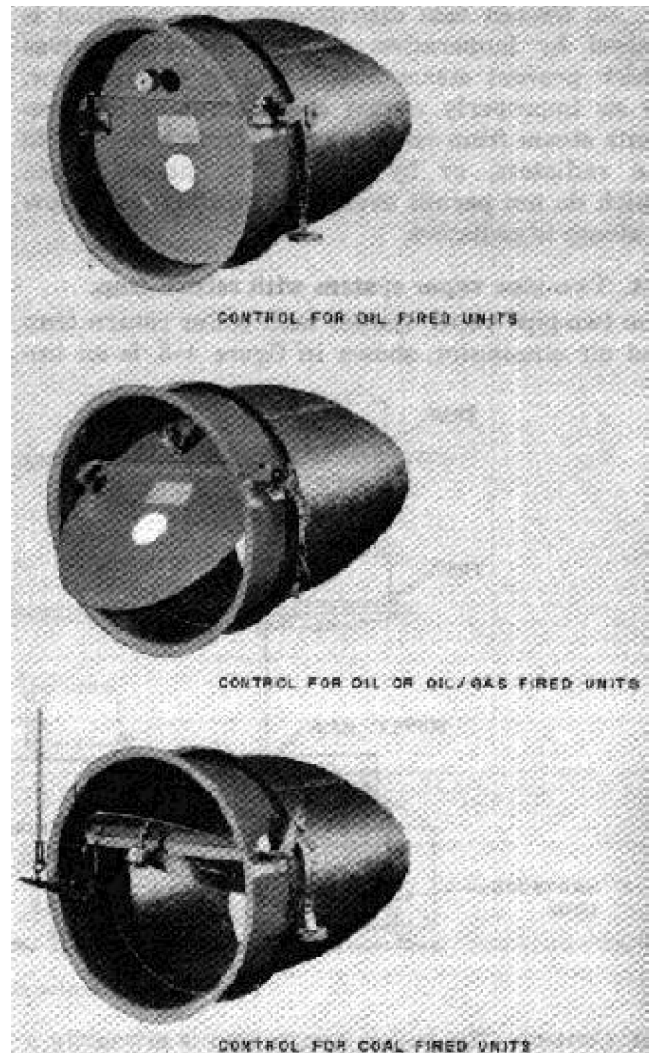

Figure 4-4. Barometric draft control.

*b. Typical operating problems.*

(1) *Radiator heat failure.* This is caused by air binding as a result of plugged or defective air vents, or by water logging due to insufficient radiator pitch (toward valve) or to partially closed radiator valves which permit trapping of condensate by the partial vacuum created.

(2) *Excessive noise.* This is caused by air vent failure and air binding of mains, insufficient radiator pitch resulting in entrapment of water, plugged or partially plugged wet return mains causing condensate to back up into steam mains, or improper pitch of mains and radiator branches.

(3) *Fluctuating water line.* This is caused by excessive pressure drop in long mains and insufficient head between the end of the main and the boiler water line to overcome the pressure drop. Grease or oil in the boiler water will also cause a fluctuating water line.

(4) *Uneven heat distribution.* This condition is caused by inoperative radiator air vent valves which prevent steam from entering the radiator, by an improperly vented steam main which prevents steam from reaching the piping branches to the radiators, or by improperly pitched pipes which do not permit even and uninterrupted flow of steam to radiators.

**4-4. Two-pipe vapor system with return trap.**

The two-pipe vapor system with boiler return trap and air eliminator, shown in figure 4-5, is an im-

provement over the one-pipe system. The return line from the radiator has a thermostatic trap which permits flow of only condensate and air from the radiator and prevents steam from leaving the radiator. Because the return main is at atmospheric pressure or less, a boiler return trap is installed to equalize condensate return pressure with boiler pressure.

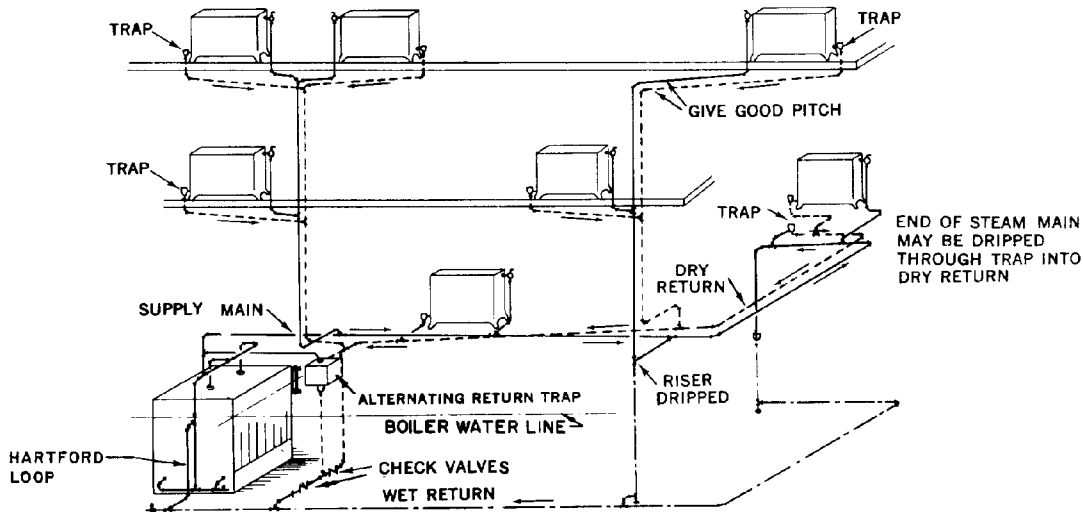

Figure 4-5. Two-pipe vapor system with return trap.

a. *Controls.* The boiler return trap is primarily a double valved float mechanism which permits equalization of boiler pressure and pressure within the return trap. The boiler return trap is installed on a vertical pipe in the return system adjacent to the boiler. The return trap has a valved steam connection to the boiler header and a vent connection to an air eliminator. Condensate rises into the return trap when the boiler is under pressure; the float-actuated vent valve is open during this part of the cycle. When condensate reaches the trip level of the trap, which is always below the bottom of the dry return, the float actuated valves reverse. The vent closes and the steam valve opens. This equalizes pressure above the condensate in the float trap with that of the boiler and causes the condensate in the trap to flow into the boiler. When low level is reached, the float actuated steam and vent valves again reverse. The steam valve closes and vent valve opens, relieves the pressure in the trap, and again permits the condensate from the system to rise into the return trap. This system is

usually air tight and can be operated at subatmospheric pressures as low as 15 inches to 20 inches of water vacuum. This system is not used with unit heaters or blast coils which cause the condensate to be returned in slugs and the rate to be variable. Appropriate controls for this type of system are similar to those for gravity systems.

b. *Typical operating problems.*

(1) *Radiator heat failure.* This is caused by plugged or defective main air vents and by radiators waterlogged due to insufficient radiator pitch toward return connection. Radiator heat failure is also caused by clogged radiator traps and center air binding due to steam entry from both the return and supply ends if the trap is leaking because of failure of the thermal element.

(2) *System heat failure.* This is caused by clogged or defective air eliminators or improper operation of return traps. Return traps must be set level and have leveling tabs for proper installation. Return trap floats usually actuate the valves through a system of balanced weight arms which

may develop incorrect adjustment. The two check valves at the base of the return trap must be in good condition and the flow must be directed toward the boiler. The air eliminator and vent valve mechanism must be cleaned periodically to assure free action. The system may bind if excessive trap leakage occurs.

(3) *Air eliminator failure.* Water spurt from the air eliminator is caused by defective return trap operation or by a clogged connection to boiler.

(4) *Water line failure or fluctuation.* This is caused by boiler pressure beyond the limit of the trap, improper adjustment of the return trap, or boiler water contaminated with oil or grease.

#### **4-5. Two-pipe vapor system with condensate pump.**

The two-pipe vapor system with condensate pump is similar to the two-pipe vapor system with air eliminator return trap, except that the condensate is returned to the boiler by a power driven centrifugal pump instead of a return trap. The system includes a separate main, radiators fed at the top, and a return system with thermostatically trapped outlets at the bottom of the radiators opposite the feed end. The return main terminates at the receiver of the condensate pump and all air in the system is vented through a vent on the receiver. With use of a condensate pump, all returns to the pump are dry and radiators may be located below the boiler water line; this is not possible in the systems previously described. Ends of steam mains are dripped and vented into the dry return main through combination float and thermostat (F&T) traps. The two-pipe vapor system with condensate pump is frequently adapted to relatively large installations, particularly when unit heaters or blast coils are used and is probably the most practical and trouble free system. In addition to the boiler pressure controls, thermostatically controlled radiator valves or zone control valves may be used, since the return system is considered to be at atmospheric or lower pressure. This permits gravity flow of condensate to the pump receiver.

*a. Controls.* The condensate pump is normally controlled by a float activated switch located either in the condensate receiver or in a pipe located at the boiler waterline.

(1) *Receiver mounted float switch.* When the condensate from the system fills the receiver to a predetermined high level, the pump starts and, in turn, stops when a predetermined low level in the receiver is reached. Water between the two levels is discharged to the boiler. In this system, there is an initial lag in return of condensate. The boiler waterline lowers until the system has filled with

steam and the return flow of condensate equals the rate of steam generation. It is therefore necessary to start a cold system with a slightly higher waterline to provide for flow of condensate in the return system and storage of condensate in the receiver. The high and low levels of the pump float valve setting should be set with adequate difference to eliminate frequent pump cycling. The settings should, however, be close enough so that the condensate discharge will not be large enough to cause excessive changes in normal boiler water level. Make-up water to this installation is supplied by manual feed or through automatic water feeders. Automatic water feeders should be set at the minimum safe boiler water level to eliminate unnecessary feed at low periods of the pump operating cycle. This pump control cycle is considered most satisfactory and results in little difficulty of operation.

(2) *Waterline mounted float switch.* With this control method the float switch is mounted in a separate chamber with pipe connections above and below the boiler water line. Since the pump may start at periods when the pump receiver is not filled, a float controlled make-up water valve is connected to the pump receiver to maintain a minimum water level in the receiver. This arrangement maintains a water level which does not vary too much and eliminates the lag of condensate feed described above. Operating difficulties encountered with this type of control usually more than offset the advantages. The float switch located on the boiler water line is a source of mechanical difficulty because of its small operating level range. If the water line control is out of cycle with the condensate return from the system, considerable make-up is used and condensate is wasted through the pump vent or overflow, unless there is surplus storage space in the receiver. The float operated receiver make-up valve is a source of unnecessary make-up of raw water to the receiver. This pump control system is suited only for systems which do not return all of the condensate to the boiler. This would include isolated buildings for which return is not practical or economical or installations where open steam jets are used, such as for dishwashers and steam tables.

*b. Typical operating problems.*

(1) *Radiator heat failure.* This is caused by inoperative traps or improper radiator pitch.

(2) *System failure.* This is caused by clogged or closed air vents at the pump receiver, by flooding of the return due to improper cut-in of the pump or by lack of pump capacity. Steam or air binding of the system caused by leaking traps may also occur.

(3) *Overflow from receiver vent.* This is caused by improper pump cut-in, inadequate pump capacity, clogged discharge piping or failure of the check valve on the pump discharge pipe. Failure of the check valve on the discharge side of the boiler feed pump permits flow of the boiler water through the pump and then to the receiver. The pump must then return the leakage to the boiler and this might be beyond the capacity of the pump. Hot condensate or hot boiler water back-up may cause vapor lock of centrifugal pumps and the pump will fail to discharge to the boiler. Overflow will occur in pumps in which float controlled make-up valves feeding the receiver are defective. This will cause excessive make-up water feed and flooding of the system.

(4) *Air returning to receiver tank and heating system.* It is advisable to provide a ball check or a vacuum vent for the air vent from the receiving tank. This type of vent permits discharge of air from the system and prevents return of air to the receiving tank and heating system. A vacuum of from 1 to 5 inches water gauge can be created if the system is tight.

#### **4-6. Two-pipe vacuum system with vacuum pump.**

The two-pipe vacuum system with vacuum pump shown in figure 4-6 is similar to the two-pipe vapor system with condensate pump. The piping system includes separate steam and return mains. Steam is supplied at the top of the radiators and condensate

and air is discharged at the bottom of the opposite end of the radiator through a thermostatic trap. All returns are dry and terminate at the vacuum pump. The vacuum pump is usually motor driven, although low pressure steam turbines are sometimes used. The vacuum pump returns condensate to the boiler and maintains a vacuum or sub-atmospheric pressure in the return system. The maintenance of a vacuum in the return system (3 to 10 inches water gauge) enables almost instantaneous filling of heating units at low steam pressure (0 to 2 psig) since air removal is not dependent on steam pressure. This system is used in all types of buildings and offers a definite advantage for operation of indirect radiation units, heating coils and ventilating units, and for other units for which close automatic control is required. Quick filling of steam elements for this system is obtained since steam spaces are under vacuum during periods of shut-off. Vacuum pumps are two general designs, positive displacement and centrifugal type. These are shown in figures 4-7 and 4-8. Both types have a centrifugal pump to return water to the boiler. The vacuum pump withdraws air and water from the system, separates air from water, expels air to the atmosphere and pumps water back to the boiler. Usually the vacuum pump is equipped with a float switch as well as a vacuum switch and can be operated as a condensate pump unit. The float switch should be used only when the vacuum system is defective and then only until defects can be repaired or corrected.

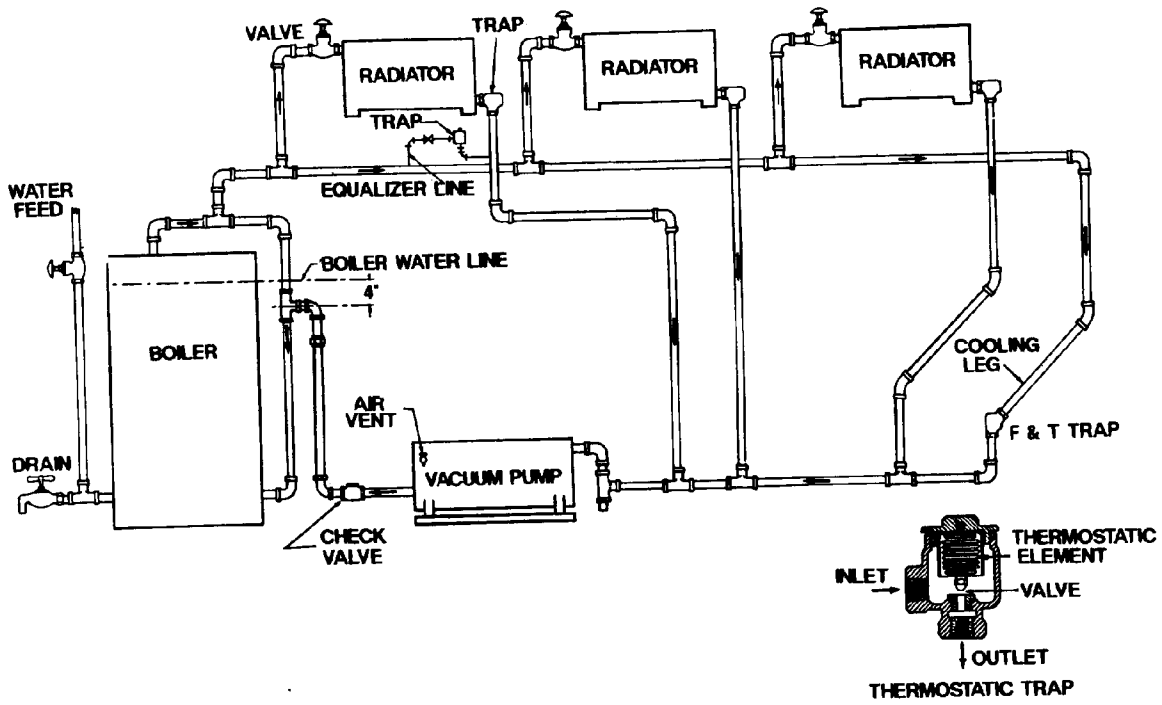

Figure 4-6. Two-pipe vacuum system with vacuum pump.

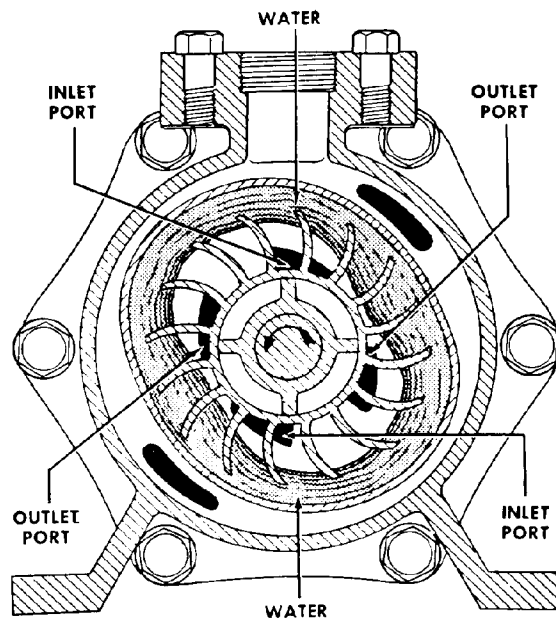

Figure 4-7. Positive displacement type vacuum pump.



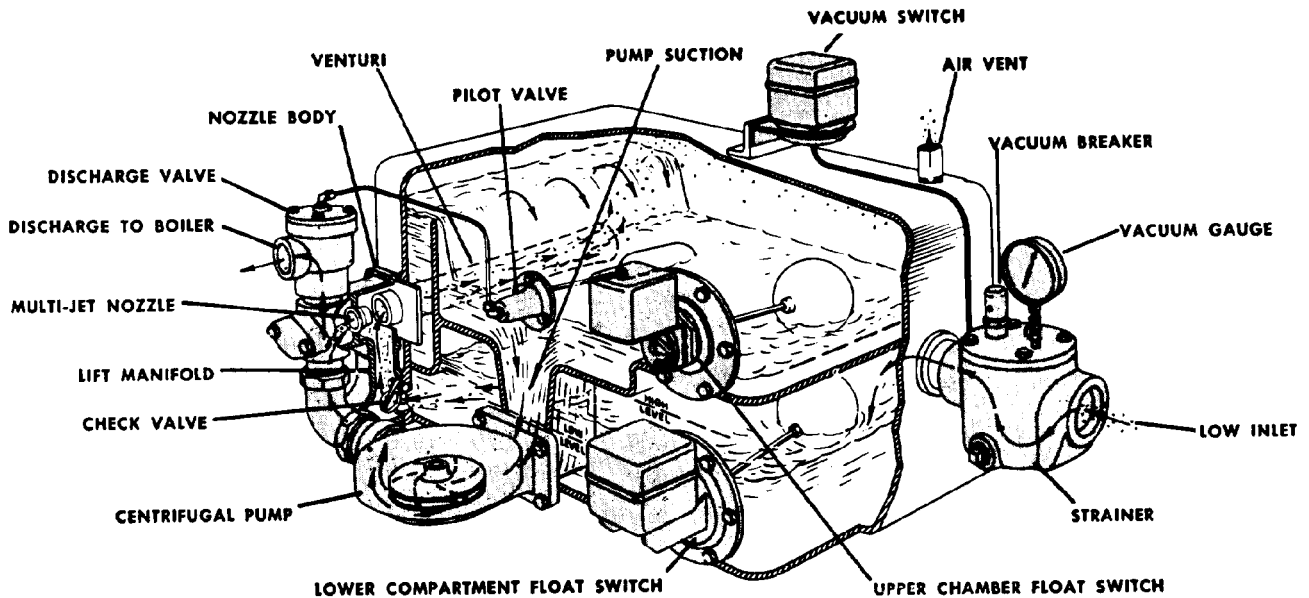

Figure 4-8. Centrifugal type vacuum pump.

a. *Controls.* Controls for vacuum type heating systems include boiler pressure control, vacuum and float control for the pump, and may include appropriate types of thermostatic or pressure controlled shut-off or modulating valves for control of heating elements.

b. *Typical operating problems.*

(1) *Radiator heat failure.* This is due to defective or clogged thermostatic traps or improper radiator pitch.

(2) *System failure.* This occurs when the vacuum pump fails to clear the system of air. The system may also fail because mains are improperly pitched or trap failures allow excessive steam leakage or water logging of steam mains.

(3) *Overflow from pump vent.* This occurs because of inadequate pump capacity; defective valves, jets, or pump clearances; or stoppage in the pump discharge connection to the boiler.

## Section II. BOILER TYPES

### 4-7. Cast iron boilers.

In general, cast iron boilers are shipped in sections and assembled at the installation site. Small boilers, however, are factory assembled and shipped as a unit. Cast iron boilers are usually referred to as sectional boilers. Figure 4-9 shows a sectional cast iron steam boiler commonly used in steam heating systems. The unit shown is an independent header type, in which each section is actually an individual boiler connected to supply and return headers. The

supply steam header is at the top center of the boiler; the return headers are located laterally near the foundation. Heated water rises through the vertical sections from the return water headers, and steam is taken from the supply steam header at the top of the unit. Cast iron boilers usually range in capacity from two boiler horsepower (1 boiler horsepower equals 33,500 BTU/hr) up to 100 boiler horsepower.

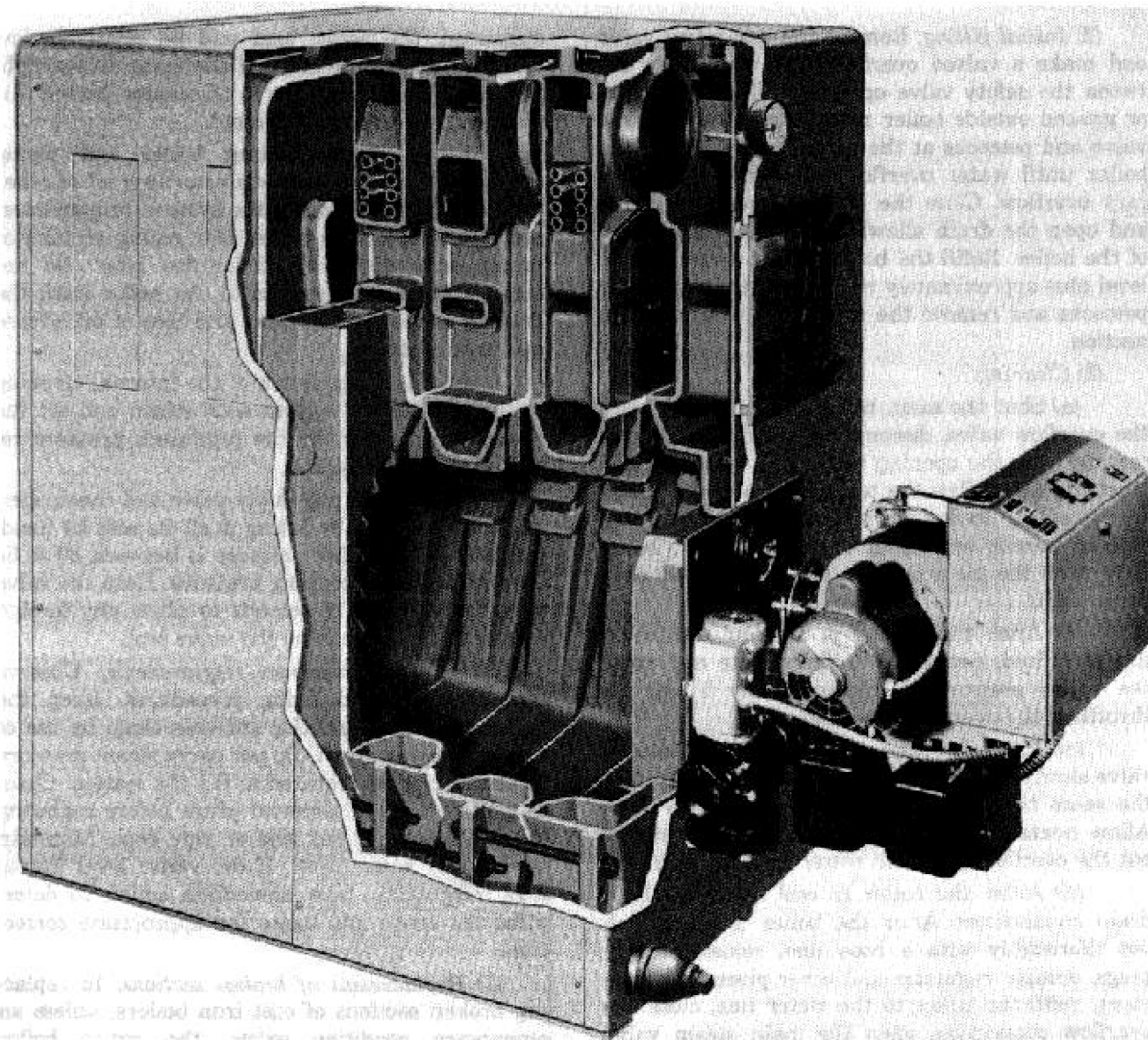

Figure 4-9. Sectional cast iron steam boiler.

*a. Initial operation and cleaning*

(1) *Checking.* Prior to start up after a prolonged shutdown, the complete installation should be carefully checked. Follow the steps described below:

(a) Examine the combustion chamber and gas passes; determine that all debris has been removed, and check burners or grates, if applicable, for proper operation.

(b) Check steam and return header-valves, gauge glass valves, and stop cocks for proper action.

(c) Check the damper regulator and connections (coal fired systems) and check draft dampers for proper action.

(d) Check for air leaks, particularly at the joint between sections and the base and between the base and foundation.

(e) Be sure that the make-up water and supply water piping is in good operating condition, condensate return equipment is properly connected, and that electrical connections are complete and properly fused.

(f) Determine the correct normal and low water levels. If the levels are not marked, place permanent markings at suitable locations on the front of the boiler adjacent to the gauge glass or on the frame work of the gauge glass. Manufacturer's literature should be used to determine the proper water level.

(2) *Initial filling.* Remove the pop-safety valve and make a valved overflow pipe connection between the safety valve opening and a floor drain or ground outside boiler room. Open the overflow valve and petcocks at the water line, then fill the boiler until water overflows through the temporary overflow. Close the water connections valve and open the drain allowing all water to run out of the boiler. Refill the boiler to the correct water level plus approximately two inches, then close the petcocks and remove the temporary overflow connection.

(3) *Cleaning.*

(a) Shut the main header steam valve, open the overflow valve, disconnect the damper regulator and plug the opening (coal fired systems), and start the fire. Allow the temperature of the water to rise slowly to dry out the setting and covering and to permit expansion to occur slowly, being sure that the tie rod nuts are maintained only finger tight.

(b) After the setting is dry and expansion has stabilized, increase the firing rate and raise the boiler pressure to approximately 5 psig by throttling the overflow drain valve.

(c) Partially open the cold water supply valve slowly, allowing the waterline to rise, and at the same time gradually open the overflow line. Allow heated water from the boiler to go slowly out the overflow line until water appears clean.

(d) Allow the boiler to cool and open both drain connections. After the boiler is cool, flush out thoroughly with a hose line, reinstall drain plugs, damper regulator and other pieces of equipment, refill the boiler to the water line, close the overflow connection, open the main steam valve and start a slow fire.

(e) Close radiator valves. Build up steam pressure gradually, sufficient to fill the piping system, and discharge all condensate to the sewer.

(f) Close the return connection to the pipe or boiler and open the bypass drain valve or disconnect the union in the return system. Feed the boiler with fresh water by careful manual operation. Continue this operation until the condensate appears clear, then cut in approximately one-fourth of the radiators. Continue steam generation until the condensate again appears clear; close the opened radiator valves and cut in another one-fourth of radiators, closing radiator valves after the condensate appears clear. Repeat until all radiators have been opened and cleaned out step by step. During this procedure, watch the water line closely and maintain it manually. If cut-in of mains and

radiators is accomplished in steps as suggested, the boiler load will be relatively low and manual maintenance of the water line simplified. Open the drain caps in the mains during this clean-out process, if convenient.

(g) A steam heating boiler and piping system will not operate satisfactorily if oil or other impurities are present in the system. Proper internal clean-out of the boiler and piping eliminates unnecessary operating difficulties later. Do not connect the return system to the boiler until the drained condensate is clear and free of oil, grease and solid matter.

(h) After completion of the internal cleaning procedure, fill the system with steam and set the pressure regulator for the minimum pressure required to fill the system.

(i) Reinstall pop-safety valve and check operation of the valve by lifting it off its seat by hand, but only when boiler pressure is between 80 to 85 percent of preset popping pressure. Keep the valve open for at least 10 seconds to allow any foreign matter to be blown from the valve seat.

*b. Special maintenance requirements.* Observe and practice good firing procedures. Keep the boiler breeching and flue surfaces clean by use of a suitable wire brush. Do not carry steam pressure in excess of that required to fill the system. Clean and oil threads of cleanout plugs before replacing them. Do not use red lead or pipe dope. Maintain the correct water level. If the water level fluctuates irregularly, take immediate action to determine the cause and make the appropriate correction.

(1) *Replacement of broken sections.* In replacing broken sections of cast iron boilers, unless an emergency condition exists, the entire boiler should be dismantled and sections cleaned, inspected and reset, using new nipples. Removal of sections usually disturbs adjoining sections and considerable difficulty may be encountered in attempting to reset only a portion of the sections instead of completely dismantling and reconstructing. Manufacturers' drawings should be consulted to determine the correct arrangement of boiler sections and proper sequence for installation of boiler sections.

(2) *Replacement of defective nipples.* Before installing new nipples, nipple ports should be cleaned with solvent and lubricated with good lubricating oil. Drive nipples squarely into sections, using a block of wood and hammer. The nipple must project outside the finished face of a boiler section  $\frac{1}{16}$  inch more than half the nipple's length. Use this rule to be certain that nipples project equally all around.

*c. Lay-up of cast iron boilers.* When the boiler is to be shut down for the summer months, remove and clean the smokepipe and reinstall it in the fall. Make all joints tight with boiler putty or cement. Clean all flues and remove soot and ashes from boiler and from the base of the chimney. Oil all door hinge bearings, damper bearings, and regulator parts. Leave doors partially open all summer to avoid condensation of moisture and rusting of interior surfaces. For water boilers, keep the system filled with water. For steam boilers, fill the boiler with water to the top of the water column. If the boiler is not to be used during the winter, draw off all of the water in the entire system. If water is permitted to freeze in boilers or radiators, breakage may result.

#### 4-8. Steel boilers.

Steel boilers for steam heating systems may be of the fire-tube type, in which combustion gases pass through the tubes while water surrounds them; or may be of the watertube type, in which water passes through the tubes and gases circulate around them.

#### 4-9. Fire-tube boilers.

Fire-tube boilers are almost universally used for low pressure, low capacity purposes, when it is desirable to move the boiler from place to place, or when simplicity of installation is desired. The various types of fire-tube boilers are the horizontal return tubular (HRT), scotch, firebox, and locomotive types.

*a. Firebox and locomotive boilers.* The firebox boiler (figure 4-10) and the locomotive type boiler are similar in most respects. However, the firebox boiler is usually used for stationary purposes only, and it has no steam dome. Firebox boilers require no setting except possibly an ash pit; as a result, they can be quickly installed and placed in service. In both types, the boiler shell extends beyond the rear tube sheet to form a smoke box or a reversing

chamber. In the straight locomotive type boiler the stack is connected to this extension, while in the firebox boiler this chamber serves to reverse the flow of gases through the upper section of tubes to the front of the boiler where they are discharged to the stack.

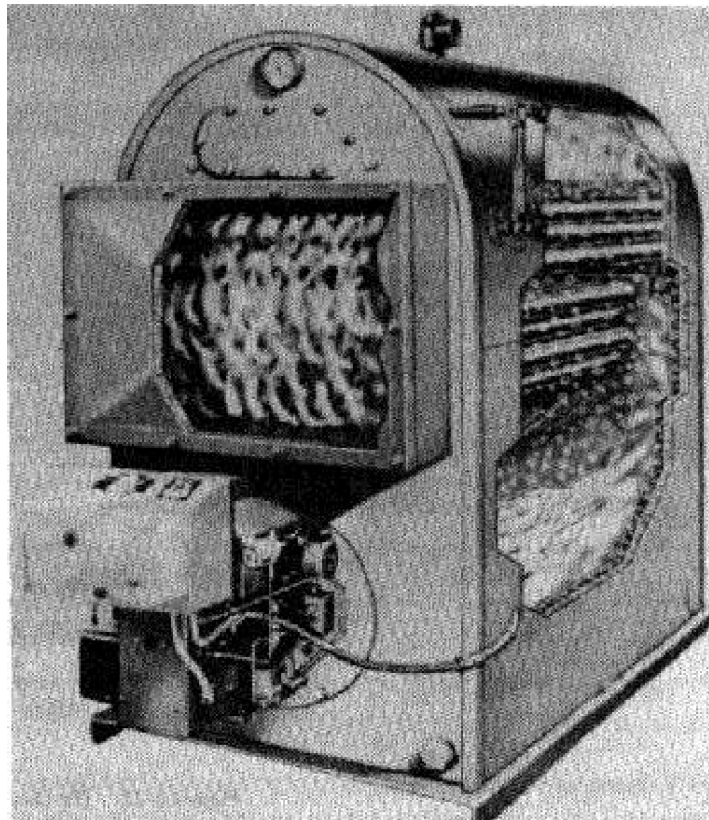

Figure 4-10. Firebox boiler.

*b. Horizontal return tubular (HRT) boilers.* The HRT boiler is not usually used for domestic heating installations, but is found in small plants because of its relative compactness, simple construction, and fuel efficiency. A major disadvantage is that it is difficult to keep the tubes and shell free from scale. Figure 4-11 shows a typical HRT boiler in a standard setting.

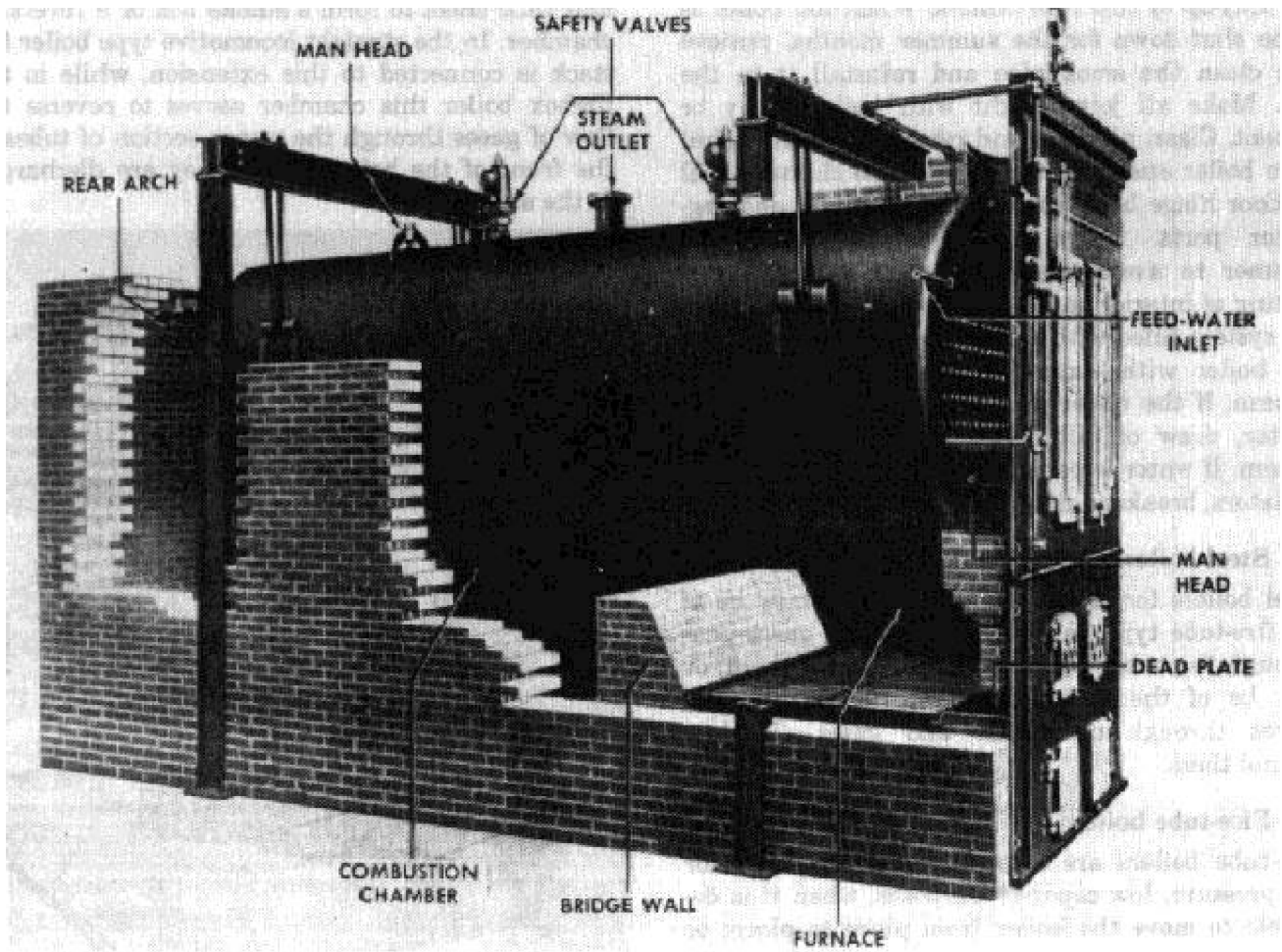
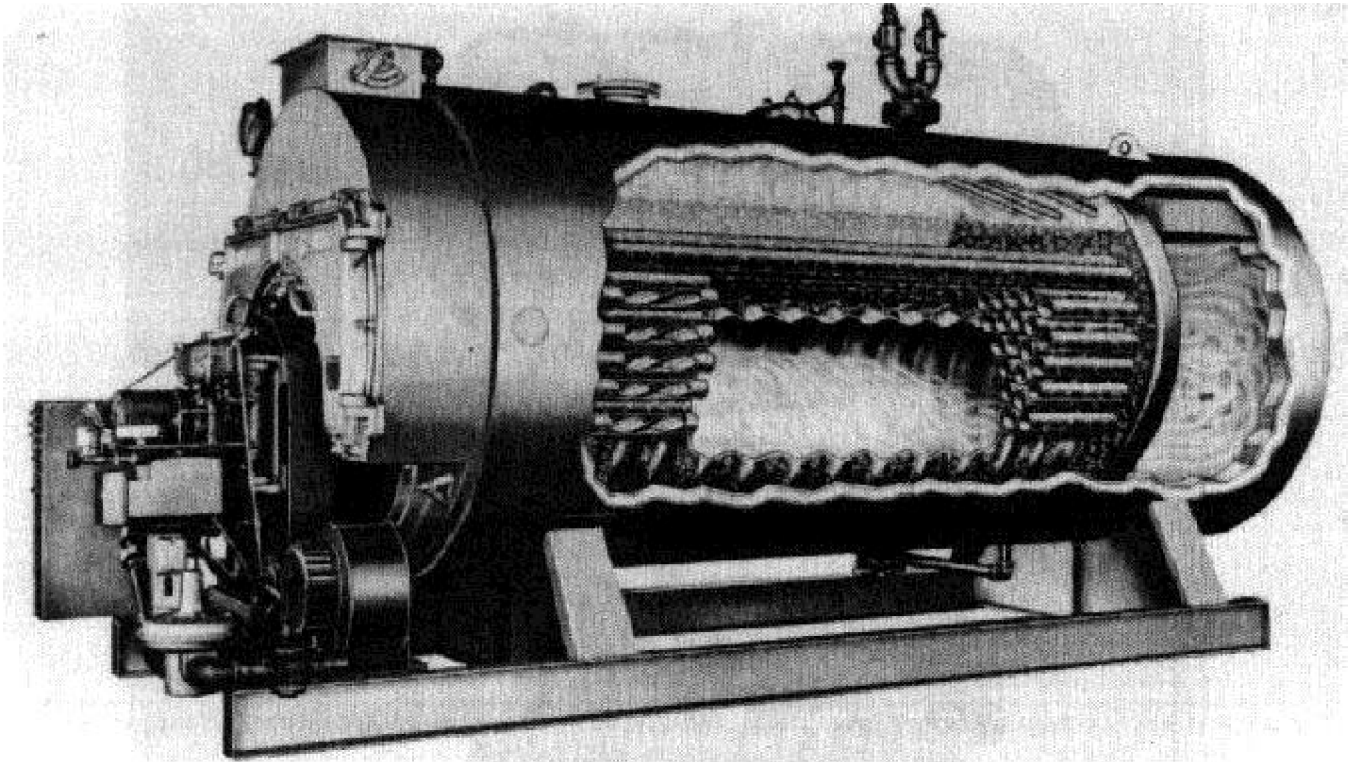

Figure 4-11. Horizontal return tubular boiler.

c. *Scotch boilers.* This type boiler (figure 4-12) is an internally fired unit, with a cylindrical furnace or firebox completely surrounded by water. The furnace is usually corrugated to add strength and allow for longitudinal expansion and contraction.

When it is operated, combustion gases pass through the furnace into a smoke box at the back of the boiler and then return through the boiler tubes to the uptake chamber at the front.

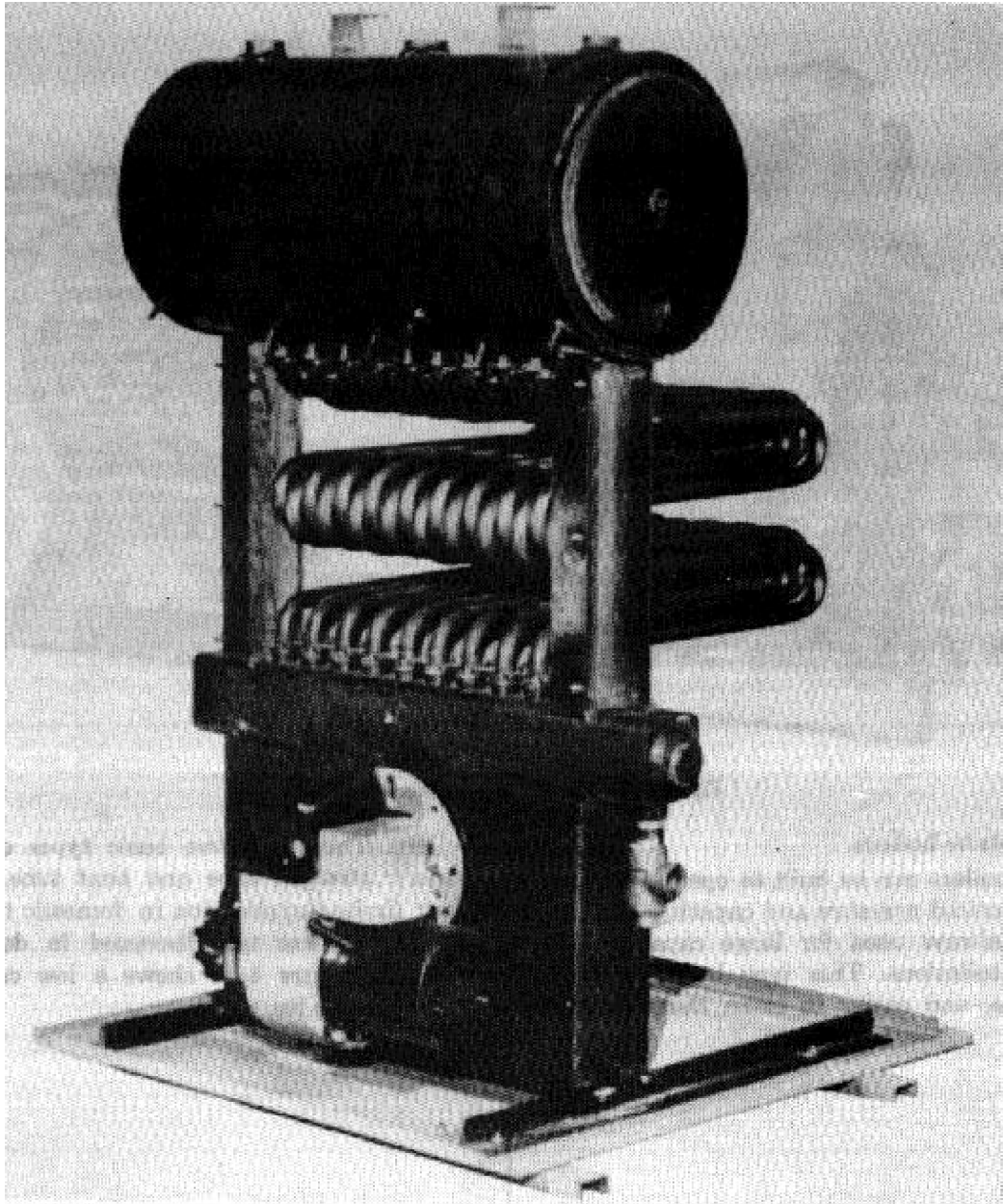

*Figure 4-12. Scotch type package unit boiler.*

#### **4-10. Water-tube boilers.**

Water-tube boilers can be built to operate at practically any desired pressure and capacity, but they are almost always used for large capacity high pressure installations. This type boiler is safer, more flexible, and easier to clean than fire-tube boilers.

There are two basic types of watertube boilers: straight tube and bent tube. Because of their limited application in domestic type installations, they are not discussed in detail in this manual. Figure 4-13 shows a low capacity bent watertube boiler.



*Figure 4-13. Bent water-tube boiler.*

**4-11. Initial operation and cleaning.**

The procedure for the initial filling, cleaning of the boiler and system, and drying out of the setting is exactly the same as that for cast iron boilers, previously described. Often, considerable water will be noted at beading of the tube ends and tube sheets of steel boilers when first filled. This should not be considered cause for alarm, as this is frequently moisture from the air which condenses on the cold steel surfaces. Observe this condition closely during the initial dry out and firing operation, after which time any condensed vapor will evaporate and any leakage will usually stop. The tubes should remain tight during all subsequent usage. If slight leakage continues, beading should

be gone over with a suitable beading tool.

**4-12. Special maintenance requirements.**

Maintenance practice for steel boilers is similar to that described for cast iron boilers. Keep the inside and outside surfaces of boilers clean and free of scale, slag, and soot. Keep combustion chambers and burners or grates clean. Remove ash from ash pits of coal fired boilers and, if applicable, remove clinkers from stokers immediately. Carry the steam pressure at minimum necessary to fill the system. Operate with a constant correct waterline. Eliminate water or steam leaks in the system and reduce make-up to a minimum.

### Section III. BOILER HEADERS, VALVES AND PIPING CONNECTIONS

#### 4-13. Installation.

Exercise care and give careful consideration to proper installation of steam and return headers for either cast iron or steel boilers. Arrange piping to permit free expansion without placing undue stress at the boiler connections. To assure proper steam delivery conditions, utilize all steam outlets of cast iron boilers. Equalize the steam supply and return headers through an interconnection in the form of a vertical line running the same pipe size as the steam supply header to the waterline, and then reducing to the return header pipe size. Connect the system return, either gravity or pumped discharge, to the vertical equalizing line, and place the bottom of the connection at the minimum safe boiler water level. This is known as a Hartford Loop. (See figure 4-14.) It eliminates unsafe lowering of boiler waterline due to back up of boiler water into the return line, which may occur due to check valve failure or excessive pressure drop in returns. Arrange pipe connections, both supply and return, to the header so that expansion and contraction in the system piping will not cause excess stress to the headers. Support pipe connections to the header with properly adjusted hangers or pipe columns to eliminate strain at boiler connections. Install a steam shut-off valve and a globe valve at the return connection to the vertical equalizing line of each boiler. Locate valves so they can be fully opened and closed without interference from building construction or other piping. Arrange the return header connection so it is readily accessible for cleaning, draining, and rod-ding, and provide it with a plugged opening. Use plugged tees instead of elbows at return connections to boilers to provide ample cleanout facilities. Connect the boiler feed or makeup connections into a common return or pump

discharge header before the Hartford Loop. Feed or makeup water should not be discharged directly into any part of a boiler exposed to the direct heat from the fire. Feed water should not be introduced through openings or connections used for the water column, water glass, or gauge cocks.

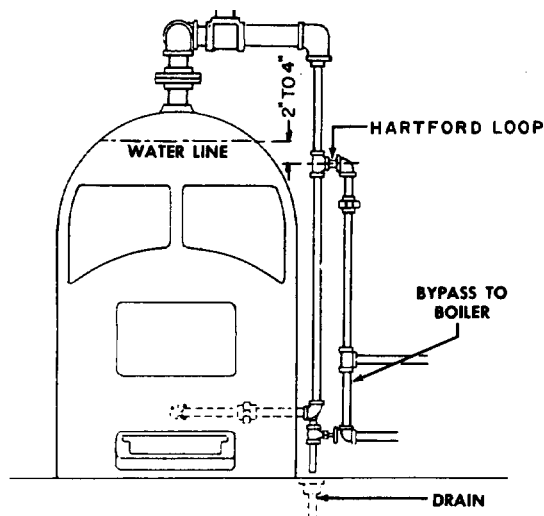

Figure 4-14. Hartford loop.

#### 4-14. Maintenance.

Maintain joints, fittings, and flanges free of leaks. Maintain proper packing in valves and do not allow the main steam valve to remain in a cracked or partially open position. This valve should be either tightly closed or fully opened to avoid corrosion and wearing of the stem, seat, and disk. Close and open this valve periodically during the heating season to check for tightness and proper operation. Open drain caps and connections periodically to flush out the return header and to assure free flow of return condensate.

### Section IV. BOILER RETURN TRAPS

#### 4-15. Installations.

All boiler return traps are similar in basic principle or construction. (See figure 4-15.) They include a float element which may either directly, or indirectly through a level linkage, actuate a steam inlet or boiler equalizing valve and a vent valve. Because the valve linkage requires close adjustment, it is necessary that the return trap be installed perfectly level and so suspended that this level will be maintained. The top of the return trap must usually be no higher than the bottom of the dry return main

and the bottom of the return trap should not be less than 6 inches above the waterline of the boiler. Piping connections should be arranged so that expansion and contraction does not throw the trap out of level. The steam or boiler pressure equalizing valve consists of a valved connection to the main steam supply header if two or more boilers are used, or a connection ahead of the boiler steam valve in single boiler installations, and has unions immediately ahead of the return trap connection to enable access to the valve mechanism. A vent or



## **TM 5-642**

return equalizing valve is connected directly to the venting unit. Two check valves are installed at the base of a valved riser to the bottom of the return trap, one on the return side and one on the supply side. The check valves should be angle type and arranged so that flow is in the direction of the

boiler. Air eliminator or vent traps are installed similar to return traps, including leveling of vent. The vent trap is installed so that the inlet from the dry return is in a straight line with the inlet to the vent trap.

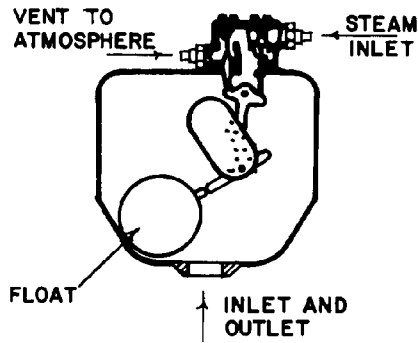

**BOILER RETURN TRAP OR ALTERNATING RECEIVER**

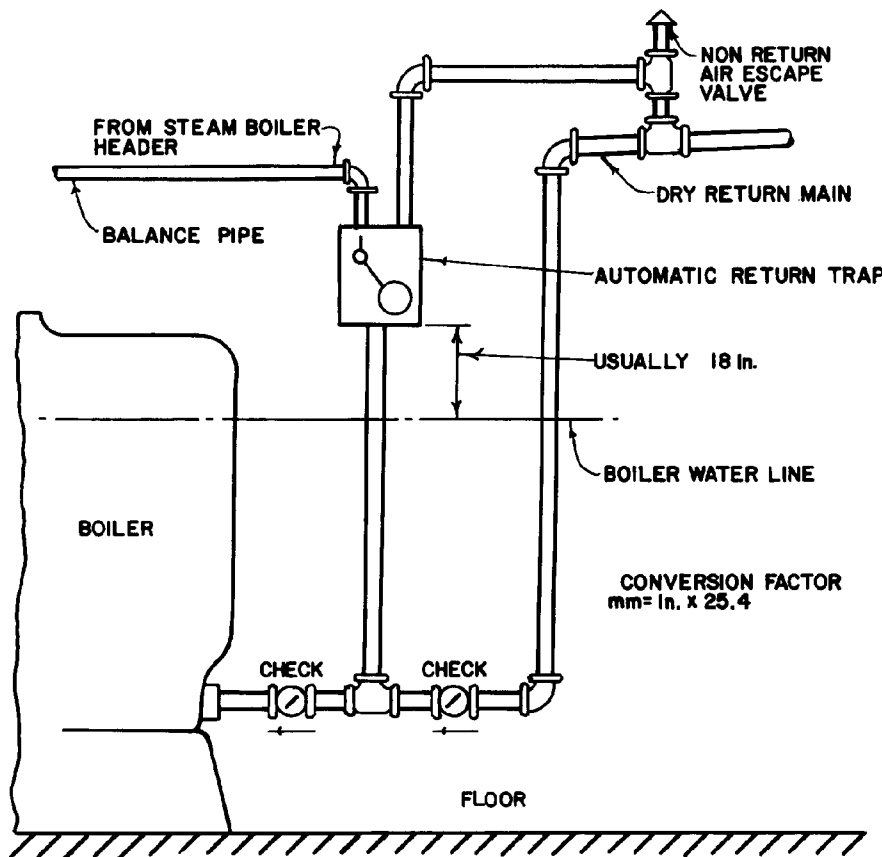

**TYPICAL CONNECTIONS FOR AUTOMATIC RETURN TRAP**

Figure 4-15. Boiler return traps.

**4-16. Initial operation.**

Keep connections to the return trap and vent traps closed during the boiler cleaning process. After completion of all connections to the vapor heating system and cleaning of the system, open the valves to the return trap. The grease and dirt from the system should not enter the return and vent trap during the system clean out process. To avoid this, condensate should be discharged to the sewer. After clean-out, raise steam pressure to the pressure equivalent of the static head between the dry return main and the waterline of the boiler. Continue to raise pressure slowly, observing the boiler waterline closely. By means of a stethoscope or a metal rod placed against the trap casing, check the return traps for tripping. The intervals between trip depends on the rate of condensate return from the system and the storage capacity of the return trap. During the pressure raising period, the sound of air leaving the vent valve of the air eliminator will be easily heard. Air vent valves or air check valves should be cleaned periodically with a dry cloth. Remove the air valve or check cap and lift out the disc or ball which is designed to permit ready and quick access for careful clean-up of the

seat and check. Clean return trap steam valve and air relief valves periodically to ensure reasonably tight seating. To clean these valves, disconnect the steam and vent connections and lift out the valve assembly or caps by means of hex head fittings provided for this purpose. Do not use emery cloth, abrasives, or files in cleaning valve seats or discs.

**4-17. Maintenance.**

Check and clean trap interior. Check for excessive wear of leverage pins and bearings and check float to assure that no leaks are present. Remove rust, scale, and grease accumulations thoroughly from moving parts by means of a soft cloth free of grit.

**4-18. Typical operating difficulties.**

In return traps, the usual difficulty is failure to return condensate to the boiler and is caused either by air binding due to failure of the air eliminator, or failure of the valve tripping mechanism because of worn parts, trap out of level, or leverage and weights out of adjustment. Defective traps should be repaired, returned to the manufacturer for adjustment, or replaced.

**Section V. CONDENSATE PUMPS**

**4-19. General.**

Pumps are generally well designed, skillfully built and rugged, but must be given the same careful attention that is necessary for any precision machine. Figure 4-16 shows a centrifugal pump and receiver set.

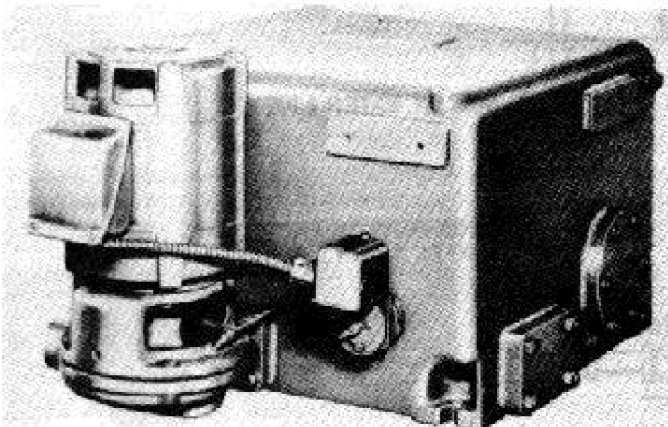

Figure 4-16. Centrifugal pump and receiver set.

**4-20. Installation.**

Pumps should be installed with short, direct pipe connections, and located so that equipment will be accessible for inspection and care. The unit should be placed so condensate flows by gravity into the

receiver. The top of the receiver must be below the lowest return to keep return lines dry. If the unit must be set in a pit, adequate drainage should be provided.

*a. Foundation.* For performance and quiet operation, the condensate pump unit is bolted to a substantial foundation. The anchorage system has anchor bolts shouldered on loose fitting vertical sleeves of pipe which are imbedded in a concrete foundation. This arrangement permits bolt adjustment to conform accurately with subbase holes after concrete is poured.

*b. Alignment.* Condensate pumps are aligned at the factory, but alignment may become disturbed. Although the unit is equipped with a flexible coupling connection which compensates for slight variations, it is desirable to obtain exact alignment as far as possible. Check the alignment by placing a straight edge across coupling halves with a thickness gauge or outside caliper at two or more points 90 degrees apart. Shim the pump or motor, or shift the motor until correct alignment is attained. Leave at least a  $\frac{1}{6}$  inch metal to metal clearance between coupling pins and faces. Adjust coupling halves on shafts so that the buffer fits loosely. Check alignment and clearances both before and after pipe connections are made.

*c. Piping.* In connecting pipes to a pump or receiver, a union is included in each line as close as possible to the unit for ease in installation or repair. Extreme care should be exercised to prevent any pipe strains upon the unit. Pipes used should not be smaller in size than their connections on the unit and should be at least one or two sizes larger if runs are long.

(1) *Condensate return line.* The condensate return line is pitched downward so that the return line remains "dry". A valved mud leg or bleeder branch is installed to permit the return system to be flushed. A gate valve is included in the line between the mud leg and receiver.

(2) *Boiler return line.* A tight seating check valve and a gate valve are included in this line. The check valve is nearer the receiver, and a plugged opening is provided for insertion of a pressure gauge for pump testing. The line is connected to the boiler by the Hartford Loop.

(3) *Vent.* For systems where boiler pressure is to remain below 15 psi, a mounted vent assembly is furnished on the receiver which includes a pet-cock and swing check valve. This requires no alterations or additions except, perhaps, to raise the assembly to a drained level when the pump is installed in a pit. Discharge from vents must be so located that they do not endanger personnel.

(4) *By-pass.* If returns and heating units are above the boiler water line, a valved bypass is provided between the receiver inlet connection and the pump discharge connection. If the heating units and returns are not above the boiler waterline, valved drains are provided.

*d. Controls.* For protection and convenience, a fused switch is always provided in the motor circuit to disconnect the motor. A standard condensate unit is usually provided with a receiver mounted float control switch which closes and opens the motor circuit at high and low water levels in the receiver tank. This switch can only control motors listed on the switch nameplate according to horsepower and current characteristics. All larger motors require, in addition, a suitable starter which affords protection against high inrush current, low voltage, high voltage, overloading, or phase failure. All polyphase motors, regardless of size, must have a starter for protection. When a starter is used, the float switch functions as a pilot.

*e. Wiring.* Electrical power connections must be made according to wiring instructions accompanying switches and motor. Conduit and wire sizes must be as required by national and local codes. The characteristics of voltage and frequency indi-

cated on the motor nameplate must be the same as those of the electrical service provided.

*f. Rotation.* Check rotation of the motor. The pump must turn in the direction indicated by the rotation arrow on the pump casing. If the rotation is incorrect, see the motor manufacturer's instructions for the procedure to be used in reversing direction.

*g. Fuses and thermal units.* Fuses should be installed which comply in size with local codes. Note fuse size advised on yellow fuse caution card, when furnished, or recommended in motor manufacturer's instructions. In general, if no motor protective devices such as magnetic starters or thermal relays are used, a fuse rated at 125 percent of motor nameplate full-load current is acceptable. If motor protective devices are installed, a fuse rated at 150 percent of nameplate current should be used. If a thermal cutout is used, see switch instructions for choice of fuse rating. In general, an element is selected with an ultimate tripping current rating not over 125 percent of motor nameplate full-load current. Fuses rated higher than those recommended should never be used.

#### 4-21. Operation.

Before putting a replacement pump into service, the heating system should be operated for several days with the condensate return line open to a drain until water appears clear. This thoroughly flushes and cleans the system to prevent clogging or damage to the new pump when condensate is allowed to enter the receiver. The procedure may take from 4 days to 2 weeks during which time the boiler water level must be maintained by addition of clean water. All pits and other floor openings should be covered or provided with guard rails.

##### *a. Before starting.*

(1) Be sure the pump and motor are lubricated according to instructions.

(2) Turn the pump shaft by hand to see that it rotates freely.

(3) See that the voltage and frequency on the motor nameplate are the same as the electrical service provided.

(4) See that switches are regulated for operation and that thermal units are set.

(5) Check motor rotation direction by closing switch contact momentarily ("bumping" the motor).

(6) Be sure valves are open on the boiler return and condensate return lines, and that the valve on the bleeder line is closed.

(7) On low pressure units, be sure the vent pet-cock is open. If it is closed, the receiver will not fill properly.

(8) Close the motor disconnect switch. The pump will not operate unless the receiver is full enough to close the float switch.

(9) Be sure all guards are in place before starting the unit.

*b. After starting.*

(1) On low pressure units, adjust the vent pet-cock so that it is open just sufficiently to allow escape of steam and air as rapidly as condensate flows into the receiver.

(2) See that motor rotates in proper direction.

(3) See that all pipe connections are tight.

(4) See that the float switch starts and stops the pump at desired levels of water in the receiver.

(5) See that the motor picks up speed quickly and maintains a constant rotation rate. If motor is brush type, see that it does not spark profusely.

(6) Check the packing-gland adjustment.

(7) Observe operation of the unit closely for 3 hours after starting and at regular intervals thereafter. A new, properly operating pumping unit should be carefully watched to note its initial performance, for later comparison checks. Consult manufacturer's instructions.

**4-22. Maintenance.**

*a. General.*

(1) At regular intervals lubricate the pump and motor as specified in lubrication instructions.

(2) Maintain proper adjustment of the packing glands and change packing when deteriorated.

(3) Keep the inside and outside of the motor and controls free of moisture, oil and dirt. If necessary blow out their interiors with a bellows. If switch contacts become corroded or pitted they should be smooth and treated with a contact preserver or replaced. If the motor is of the brush type, replace the brushes when necessary.

(4) Wearing parts on centrifugal pumps, such as bearings and wearing rings, are readily accessible. To get peak performance, check these parts at intervals depending upon severity of service, and replace worn parts if necessary.

(5) To ensure the best operation of the unit make a systematic inspection periodically.

*b. Packing boxes.*

(1) *Gland adjustment.* Adjust packing glands so there is a weep or slight leakage of water around the shaft when the pump is operating. This is necessary for cooling and lubrication, and keeps the packing in good condition. To adjust glands,

tighten or loosen the two gland nuts evenly a few turns. Do not make glands too tight. After adjustment, turn the shaft by hand to be sure it rotates freely. If proper adjustment cannot be attained without shaft binding, the packing should be replaced. Provide proper drains from pump bases.

(2) *Packing replacement.* Occasionally packing will require replacement because of normal wear or improper gland adjustment which causes drying or burning. Use only soft, square, packing of proper size. Cut packing into rings which will fit snugly around shaft with ends just meeting. Be sure the ends are square. Remove gland nuts, take out gland halves and pick out old rings of packing. Clean the shaft and packing box of dirt or sediment and insert packing rings, pushing each succeeding ring back into place. Stagger packing ring joint ends to ensure a good seal. Reinstall gland halves, bolts, and nuts, and be sure that gland followers enter the packing box to a depth of at least  $\frac{1}{8}$  inch. Adjust the glands.

*c. Shutting down.* When shutting the pump unit down for any considerable period, open the motor disconnect switch. Drain the unit by removing drain plugs at the bottom of the receiver tank and pump casing until all water drains out. Never expose the pump unit to freezing temperatures when filled with water. Cover the motor and switches to protect them against dust and moisture.

*d. Pump lubrication.* Keep a regular lubrication schedule and avoid both over and under lubrication. When oil lubrication is used, a good grade neutral, medium viscosity, mineral oil is satisfactory. Grease lubrication requires more careful lubricant selection, because there are a great many products from which to choose. The important factors in choice of grease for a pump are: its resistance to water, determined by the soap-base used in its manufacture; and its consistency as related to operating temperature and method of application. Lime-soap-base greases are relatively insoluble and non-emulsifying and should be used where water may come in contact with the bearing. The higher the operating temperature, the heavier the grease should be. Use only ball bearing lubricants for grease lubricated ball bearings; never use graphite. Lubricate the motor according to directions on the motor instruction sheet.

**4-23. Typical operating difficulties.**

*a. Pump fails to operate.*

(1) Fuse blown or thermal unit is tripped or loose.

- (2) Shaft binding, or impeller blocked.
- (3) Switch contacts corroded or shorted, or terminal connections broken somewhere in circuit.
- (4) Float control mechanism not functioning or float waterlogged.
- (5) Wiring hookup or electrical service provided is incorrect, or switches are not set for operation.
- (6) Motor is grounded or burnt, or brushes, when present, are stuck or worn.
- (7) Electrical service or phase failure.
- (8) Receiver vent is not open.
- b. Fuses blown or thermal units trip.*
  - (1) Fuse rating used is incorrect.
  - (2) Shaft is stuck or not rotating freely.
  - (3) Loose connection somewhere in circuit.
  - (4) Controls are worn or arcing.
  - (5) Motor is grounded or partially burnt out.
  - (6) Brushes, when present, are sparking profusely or sticking. Commutator is scored or brushes worn.
  - (7) Motor is overloading.
  - (8) Fuse or thermal unit location is too hot if placed near boiler or flue.
  - (9) Short circuit in wiring.
- c. Pump runs continuously.*
  - (1) Float is stuck in raised position.
  - (2) Float switch adjustment is improper.
  - (3) Switch contacts are burnt closed.
  - (4) Pump is "steam bound" due to very high water temperature.
  - (5) Discharge head is higher than anticipated.
  - (6) Motor speed is too slow or voltage low.
  - (7) Pump is defective or capacity too small.
  - (8) Receiver is dirty. Pump suction clogged.
  - (9) Vacuum in receiver is reducing discharge head on pump. See that vent is open.
- d. Pump operates at slow or variable speed.*
  - (1) Switch contacts are arcing.
  - (2) Loose connection in electric circuit.
  - (3) Low voltage, or phase failure in polyphase electrical service.
  - (4) Motor is partially burnt or grounded.
  - (5) Motor brushes, when present, are worn, stuck, or spring tension is weak. Commutator may be corroded.
  - (6) Clutch is defective in single phase repulsion induction motor.
  - (7) If shaft is binding, check for improper gland adjustment, impeller rubbing, impeller clogged, or a bent shaft.

#### 4-24. Steam pressure pumping systems.

*a. General.* This type of condensate handling system is an energy saving, highly efficient way to pump or lift liquids in many types of operations. It is particularly suited for effectively handling condensate from all types of heating and processing equipment. Instead of using motor driven pumps, this system uses steam or other gases under pressure as the motive force. Unlike conventional condensate pumps, a steam powered pump can handle temperatures over 185 °F without the need for venting or cooling. It requires no high maintenance stuffing boxes, motors or starters. It contains no revolving shafts and utilizes a minimum of moving parts.

*b. Operation.* Figure 4-17 shows the operating cycle for one type of steam powered pumping system. Condensate from the equipment being drained enters the receiver tank and flows down the fill line into the equalizing chamber (figure 4-17(1)). When a predetermined high level is reached in the equalization chamber, the level control system sends out a signal which causes the 3-way valve to cycle. When this valve cycles, the vent line is closed off and high pressure steam is admitted to the equalization chamber. This steam pressure is confined above the condensate in the chamber and its effect is to move the condensate out of the chamber and into the discharge line. When the condensate reaches a predetermined low level, the level control system sends another signal causing the 3-way valve to revert to its original position. Residual steam remaining in the equalizing chamber will flow through the vent line into the receiver enabling the pressures in the two tanks to equalize with each other. When this is completed, flow of condensate from the receiver tank to the equalizing chamber will start again. The cycle then repeats itself.

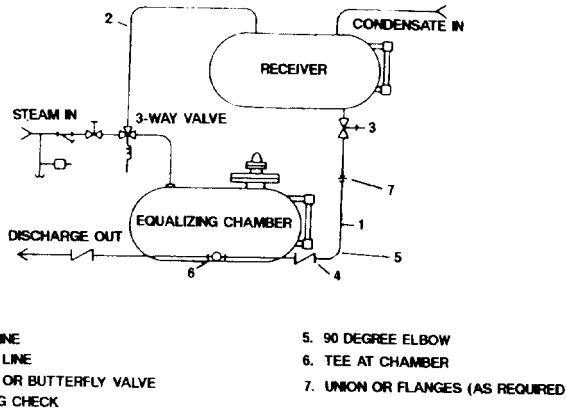

- 1. FILL LINE
- 2. VENT LINE
- 3. GATE OR BUTTERFLY VALVE
- 4. SWING CHECK
- 5. 90 DEGREE ELBOW
- 6. TEE AT CHAMBER
- 7. UNION OR FLANGES (AS REQUIRED)

a.

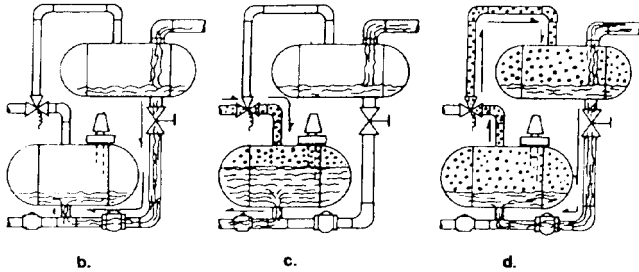

b.

c.

d.

Figure 4-17. Steam pressure pumping.

(1) *Fill cycle.* When condensate from equipment being drained enters the receiver, it will also enter the fill line connecting the two tanks (figure 4-17(2)). Since the 3-way valve is not energized, its normally open port will allow both tanks to be pressure equalized through the vent connection. Therefore, the flow of condensate is by gravity head only. Typically, gravity head is 1 to 3 psi. Therefore, it is important that friction losses be minimized. While filling is taking place there is no steam flow through the 3-way valve and no condensate flow into the discharge line. The check valve in the discharge line prevents back flow into the equalizing chamber. The fill cycle is complete

once the condensate reaches the predetermined high level of the equalizing chamber. At this moment the level control device sends a signal causing the 3-way valve to actuate. This signal can be electrical or pneumatic. When the 3-way valve actuates, it closes its normally open port in the vent line and opens its normally closed port in the steam line.

(2) *Equalization and discharge cycle.* The steam flow through the 3-way valve enters the equalizing chamber at a point above the condensate (figure 4-17(3)). The initial pressure in the tank immediately begins to increase. Until tank pressure exceeds discharge line pressure no condensate will be discharged. This period is called the equalization cycle and represents a small fraction of the discharge cycle. As the tank pressure increases above discharge line pressure, condensate flow starts and will continue until the predetermined low level is reached. At this time the level control device sends a signal which allows the 3-way valve to revert to its original position.

(3) *Vent cycle.* Several events take place during the vent cycle (figure 4-17(4)). In its closed position, the 3-way valve prevents high pressure steam from entering the equalizing chamber, but its normally open port will allow the steam used for discharge to flow into the receiver through the vent line. Until this steam pressure is equalized with the receiver, no condensate flow will occur between the two tanks because the residual pressure keeps the fill line swing check closed. Condensate entering the receiver during discharge and vent cycles remains in the receiver until the next fill cycle begins.

*c. Troubleshooting.* As with any troubleshooting procedure, care should be exercised when disassembling a pipe line, valve or other pressure fittings. Steam and condensate lines should be valved off and initial inspection should be made to ensure that no residual pressure remains in the valved off section(s). This same care should be followed when working with the electrical components. A troubleshooting guide for steam pressure powered pumping systems is in appendix C.

## Section VI. VACUUM PUMPS

### 4-25. General.

a. The usual vacuum pump unit consists of a vacuum section which withdraws the air-vapor mixture and discharges air to the atmosphere, and a water removal unit which discharges condensate to the boiler. The vacuum pump unit is furnished

complete with a receiver, separating tank, and automatic controls mounted as an integrated unit on one base. There are also special steam turbine driven units which are operated from the heating system steam supply. Under special conditions such as an installation where it is necessary to return condensate to a high pressure boiler, auxiliary

water pumps are supplied. In some instances separate air and water pumps are used.

b. For rating purposes, vacuum pumps are classified as low and high vacuum. Low vacuum pumps are those rated for maintaining less than 5½ inches of mercury vacuum in the system and high vacuum pumps are those rated to maintain vacuum at or above 5½ inches.

c. It is essential in vacuum installations that the entire system is tight in order to reduce the amount of inward air leakage. Furthermore, it is essential that very high temperature steam is prevented from entering vacuum return lines through leaky traps and high pressure drips. The condensate from equipment using steam at high pressure should not be connected directly to a vacuum return line, but

should drain to a receiver or flash tank through a high pressure trap. The receiver should have an equalizing connection to a low pressure steam main and drain through a low pressure trap to the vacuum return main.

**4-26. Installation.**

a. *General.* Figures 4-18 and 4-19 illustrate correct methods for installing vacuum pump units. In connecting pipes to the pump or receiver, a union is included in each line as close as possible to the unit for convenience in installation or repair. Pipe stress upon the unit should be prevented. Pipes used should not be smaller in size than their connections on the unit and should be at least one or two sizes larger if runs are long.

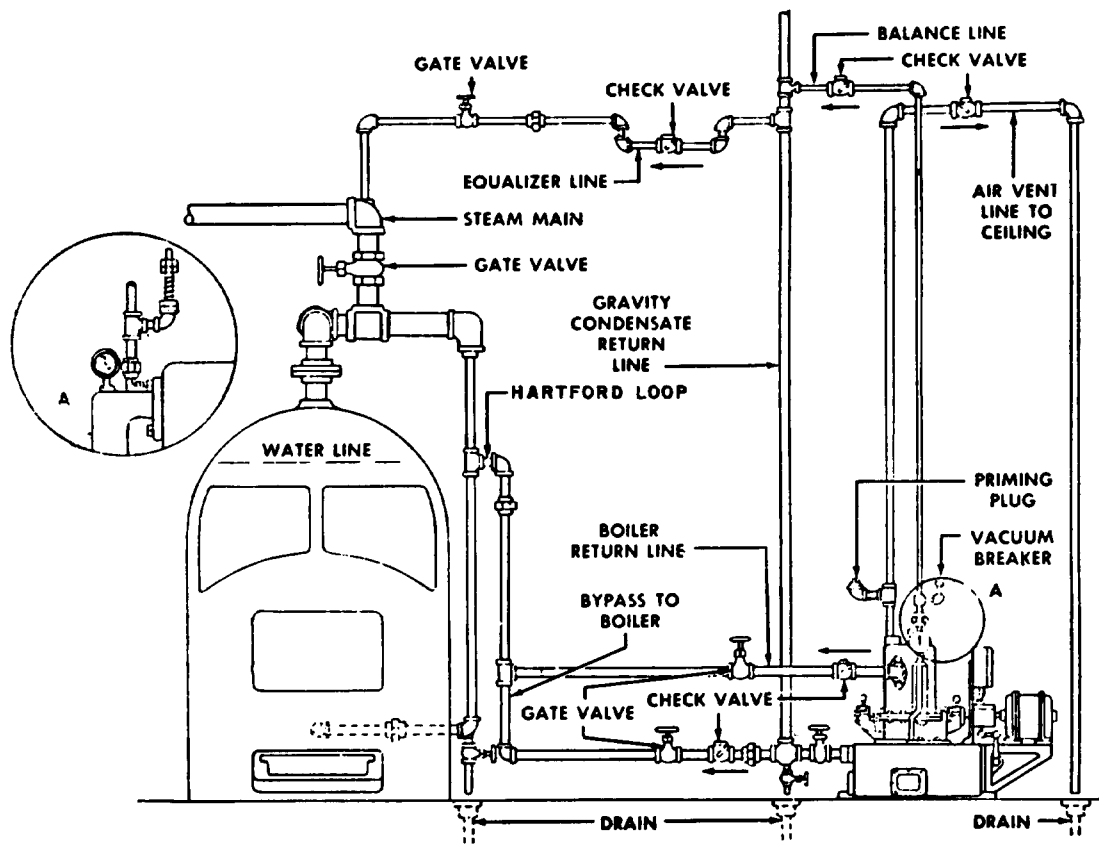

Figure 4-18. Single vacuum pump installation.



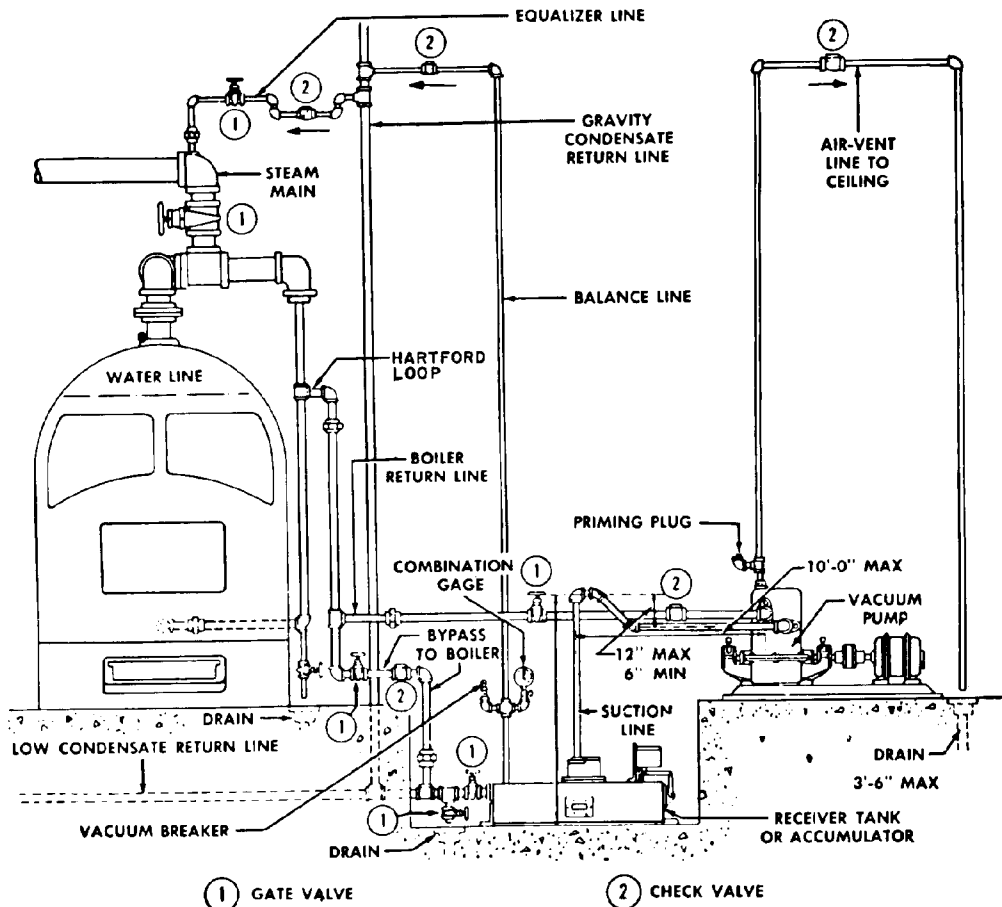

Figure 4-19. Single vacuum pump installation with accumulator tank.

*b. Pipe connections.*

(1) A valved connection to a drain in the condensate return line is installed to permit draining or flushing of the system.

(2) A valved bypass from the condensate return to the boiler return line is installed to permit operation by gravity in case of a power failure.

(3) The boiler return line is connected by Hartford Loop.

(4) A receiver vent or equalizer line to a dry vertical return riser is used to permit a continuous flow of condensate into the receiver.

(5) An air-discharge vent line with a horizontal switch check valve is run up to a point as close to the ceiling as possible and back down to a drain.

(6) A dry equalizer line between the condensate return line and steam header, including a gate valve and tight seating check valve, is used to equalize boiler vacuum when steam is shut off and to permit normal return of condensate to pump receiver.

(7) Pipes must be airtight and all steam traps must be of a suitable type, properly located, and in good operating condition.

**4-27. Controls.**

The vacuum pump is controlled by a vacuum regulator which cuts in when the vacuum drops to the lowest point desired and cuts out when the vacuum has been increased to the highest point. These points are varied to suit particular system or operating conditions. In addition to this vacuum control, a float control is included which automatically starts the pump whenever sufficient condensate accumulates in the receiver, independent of the amount of vacuum in the system. A selector switch is usually provided to allow the vacuum pump to operate as a condensate pump. This operation takes place on float control and when vacuum control is in the off position. The selector switch also provides manual or continuous operation when desired. A fused motor-disconnect switch is always

provided in each motor circuit. Exclusive of continuous duty models, all standard vacuum pump units are furnished with automatic controls necessary for requirements of the motor furnished. A float switch governed by the water level in the receiver and a vacuum regulator controlled by the vacuum in the system are provided. In addition, all vacuum pump units have a three-way selector switch for choice of continuous operation, operation with float and vacuum control, or operation with float control only. This permits, among other things, cutting out the vacuum regulator when vacuum is not required.

#### 4-28. Initial operation and cleaning.

Piping systems may contain considerable quantities of scale, grease, dirt, or metal shavings. To protect against damage from foreign material, the heating system should be operated for 2 weeks with the condensate return line open to a waste drain before the pump is first put into operation.

a. *Before starting* Check the following items before starting the unit.

(1) Be sure the pump and motor have been lubricated as indicated by the manufacturer's lubrication instructions.

(2) Turn the shaft by hand to see that it rotates freely.

(3) See that the characteristics of voltage and frequency on the motor nameplate coincide with the electrical service provided. Check to see that all thermal units are "set" for operation.

(4) See that the drain valve is closed and all necessary line valves open.

b. *Priming the pump.* Most vacuum pumps must be primed before the pump is put into operation. To do this, remove the priming plug which is on the air vent line just above the pump and pour clean water through the elbow fitting into the pump casing. Replace the plug.

c. *Starting the pump.* Set the selector switch for float and vacuum control, or continuous operation, and close the motor disconnect switch.

d. *After starting pump.* After the pump has been started check the following items.

(1) See that the shaft rotates in the direction indicated by the rotation arrow on pump. Vertical units rotate clockwise looking down the motor. Horizontal units rotate clockwise looking at the pump from the motor end.

(2) On larger units, check the flexible coupling connection of the pump and motor shafts, and note if the pump is noisy. If so recheck for improper alignment or clearance.

(3) Check pump operation and control adjustment by closing the gate valve on the condensate

return line and running pump on float and vacuum control. Observe the operating time necessary to create the vacuum for which the pump is set.

(4) Open the gate valve on the condensate return and check the time required for the pump to create a vacuum in return system, keeping in mind that in large systems a reasonable period may normally be necessary.

(5) Check the packing boxes for proper leakage.

(6) After the pump is in operation, clean the inlet strainer as required by the manufacturer's instructions.

e. *Vacuum regulation.* Regulate the pump to create the vacuum desired by adjusting a spring tension nut in the vacuum control switch according to directions given in the switch instructions. The normal range is from 2 to 6 inches of mercury vacuum.

f. *Vacuum breaker valve.* The vacuum breaker or relief valve is usually set to open at 10 inches of mercury and is adjusted by regulating the tension of the valve spring. The relief valve ordinarily requires no special care. It is used to relieve excessive vacuums that might result when float control is still activated after the desired vacuum has been created.

g. *Selector switch.* Selector switches provided on vacuum pump units with automatic control have three positions for pump operation marked Continuous, Float and Vacuum, and Float Only. Properly handled, this feature permits a flexibility of operation yielding both economy and effective pump performance. A few recommendations for operation of the selector switch are given below:

(1) "*Continuous*". The pump will run continuously independent of float or vacuum switches. This mode of operation is used:

(a) To run the pump continuously for trial test, or under unusual service conditions.

(b) To ensure rapid heat-up in the morning.

(2) *Float and vacuum.* Pump operation is governed by either vacuum regulator or float switch. The pump operates when water is accumulated beyond a set level in the receiver tank or when vacuum in the return system falls below the minimum setting. The pump should be operated at this position for normal and heavy duty.

(3) "*Float only*." The pump is governed by the float switch only and the pump operates when return condensate in the receiver rises above high water level. Operation is independent of the

vacuum control switch. Do not operate the pump at this position unless condensate flows into the pump receiver by gravity. This position is used:

- (a) When shutting down steam.
- (b) For night operation.
- (c) Where service is light as when the system is tight enough to hold sufficient vacuum between float actuated operations, or when excessive piping leaks cause difficulty in maintenance of vacuum.

**4-29. Maintenance.**

*a. Lubrication.* Lubricate the motor and pump at regular intervals as indicated by lubrication instructions.

*b. General cleanliness.* Keep the interior and exterior of the motor and controls free from moisture, oil, and dirt. Blow out their interiors using a bellows when necessary. When switch contacts show signs of wear or pitting they should be smoothed, resurfaced and treated with a contact preservative. Replace contacts which cannot be smoothed.

*c. Packing boxes.* Give packing boxes the same care given those in any ordinary water pump. No vacuum is exerted on the packing boxes and they rarely require repacking. Observe the packing glands occasionally for leakage. A slight “weep” of water or about 30 drops per minute from the glands while the pump is in operation keeps packing in good condition. If serious leakage is noted, tighten the glandnuts evenly a few turns only. Do not draw glands too tight. After adjusting the packing glands, turn the shaft by hand to be sure it rotates freely. If serious leakage will not stop, see manufacturer’s instructions for packing renewal.

*d. Periodic inspection.* For efficient operation, inspect the pump periodically as recommended by manufacturer’s instructions.

(1) Check the automatic controls. See that the pump responds to vacuum and float switches properly.

(2) See that the motor comes up to speed quickly and maintains a constant rotation rate. If the motor is a brush type, see that it does not spark profusely while starting or running.

(3) The quickest and most effective test of the pump is to shut the condensate return valve, run the pump on float and vacuum control, and check the time requirement for the pump to attain a vacuum which it can hold. If the pump performs satisfactorily with the condensate return valve open, the trouble lies in the system, not in the pump.

(4) Check stuffing boxes for proper packing weep as described.

(5) Remove receiver handhole cover to inspect receiver tank. Flush out sediment.

**4-30. Typical operating difficulties.**

*a.* If pump will not run with selector switch at the “continuous” position:

- (1) See if motor disconnect switch is open.
- (2) See if fuse is loose or blown out and whether thermal units are tripped or simply not set.
- (3) Check wiring for broken terminal connections or improper hookup.

(4) Check motor to see if it is burned out or shorted. If the motor is a brush type, see if a brush is worn or stuck.

(5) See if pump shaft is stuck. Try turning shaft by hand.

*b.* If pump will not run with selector switch in “Float Only” position when receiver is full of water:

- (1) See if float is stuck or waterlogged.
- (2) Check float switch contacts for corrosion or pitting.

(3) Check float control mechanism. See that adjustment is correct and that all keys or pins are in place.

(4) Check wiring to float switch.

*c.* If pump will not run with selector switch at “Float and Vacuum” position when vacuum is below set minimum and receiver is empty:

(1) See if vacuum switch contacts are corroded or pitted.

(2) See if vacuum switch regulation is correct.

(3) Check wiring to the vacuum switch.

*d.* If fuses blow out or thermal units trip:

(1) Check fuse or thermal unit rating used.

(2) See if fuse location is too hot. Boiler room temperature may be high.

(3) Turn the pump shaft by hand to see that it is free. Sticking may be caused by glands which are unevenly or too tightly adjusted, clogging or pump, extreme wear of pump or motor bearings, or rubbing of impeller or rotor within the pump due to improper clearance adjustments.

(4) Check wiring. Test for loose connection or short circuit.

(5) See that the motor is not grounded or partially burned out.

(6) See that switch contacts are not worn or arcing.

(7) Check brushes, when present, for excessive sparking while running or starting, or for sticking. See if commutator is dirty or scored.

(8) See if the motor is overloading.

*e.* If the pump runs continuously, turn the selector switch to "Float Only Position". If pump continues to run:

(1) Check float control mechanism for stuck float.

(2) See if excessive condensate is returning to the pump as during morning heat up or when shutting down steam.

(3) Check float switch contacts for burning.

(4) See that accumulated sediment in the receiver tank is not holding the float up.

*f.* If the pump runs continuously, turn selector switch to "Float and Vacuum position". Continuous pump operation on vacuum control is usually caused by excessive air leaking into the system (leaky flanges, broken fittings, defective valves and packings, etc.), by excessive condensate temperature (due to leaking traps, etc.), by a defective control element, or by inadequate pump capacity. If the pump continues to run:

(1) Check vacuum switch contacts for burning or pitting.

(2) See if there is a vacuum, or practically no steam pressure present.

(3) See that the vacuum breaker valve is not opening below the minimum setting of vacuum switch.

(4) Check piping connections to the vacuum switch. Be sure this line is open and unobstructed.

*g.* If the pump does not produce or maintain a vacuum with valves in condensate return line closed:

(1) See if prime water has been lost.

(2) Test air-relief check valve and inlet check valve for leakage.

(3) Replace worn or deteriorated discs.

(4) Inspect the pump thoroughly for gasket leaks.

(5) Check the packing nut on float control for leakage

(6) Check motor rotation direction and speed, and supply voltage.

(7) See if the condensate is so hot that it flashes into steam under vacuum. If so, the traps in the system are allowing steam to pass. When this condition is very bad, a slight pressure is sometimes indicated on the combination gauge. Steam is sometimes seen pouring out of the air vent and the pump casing is very hot to the touch.

(8) Check for air leaks in the receiver tank or manifold as at plugs and casting holes.

(9) Inspect for clogged inlet strainer or clogged lift pipe.

(10) Check pump discharge pressure. The pump impeller may be clogged or worn.

*h.* If the pump does not produce or maintain a vacuum with condensate return valves open but does so with valves closed:

(1) Check the system for leaky or ineffective traps or for a branch where traps were not installed.

(2) Check the system for leaks in the return line as from an open pipe end or loose connection.

(3) Test check valves in the equalizer line between the steam main and condensate return line, and in the bypass between the boiler return line and the condensate pump.

(4) Be sure that the heating system is not banked or operating with low firing. This will allow traps to stay open so that no vacuum can be created in the return system.

*i.* If the pump loses its prime:

(1) Test the inlet check valve for leakage. For rapid test of the valve, break vacuum by tripping the vacuum breaker valve manually, remove the strainer handhole cover, prime the pump, and observe whether prime water is leaking through.

(2) Look for simultaneous leakage of check valves on the air vent line and in the bypass between the condensate return and boiler return lines. Loss of prime from this leakage usually occurs at night or during a low-fire period.

(3) See that the packing boxes are not leaking excessively.

(4) See that the casing drain plugs are not out or loose.

*j.* If water floods over the vent line when the pump is not in operation:

(1) Be sure switches are set for operation so that pump can run.

(2) Be sure a Hartford Loop has been used and that the air vent line has been run as high as possible.

(3) See that the float-control mechanism is operating and that the pump responds to float switch.

(4) See if the check valve in the discharge line to the boiler is leaking or installed backwards.

*k.* If water floods over the vent line when the pump is in operation:

(1) See that the check valve in the boiler return line is not stuck, or closed, or installed backwards. Be sure the boiler return line is not clogged.

(2) Be sure the pump is returning water to the boiler. Check pump rating and the discharge pressure, and compare with the existing discharge head.

(3) Inspect vent strainer to see that it is not dirty or greasy allowing pressure to build up in the hurling chamber and preventing separation of vapor and water.

(4) If flooding occurs when the pump is first started as at the start of the morning heat up, see if condensate has been trapped or accumulated in quantity within the return piping and receiver. By running the pump at Float Only control at night, this is avoided.

(5) See if the lift pipe is clogged at the bottom. Be sure sediment has not accumulated in the receiver tank.

*l.* If operation of pump is noisy:

(1) See if prime water is lost or if the pump is flashing steam.

(2) See if the pump is operating at a high vacuum.

(3) See if the inlet strainer is clogged.

(4) See if the lift pipe is clogged.

(5) Check installation for pipe strains, poor anchorage, or improper alignment of pump motor

shafts.

(6) Check bearings for wear or deterioration.

(7) Check whether receiver is flooded. Also check the float switch adjustment. See if the float switch adjustment is improperly regulated allowing the receiver to overflow flooding the lift pipe.

(8) Inspect the hurling water chamber, inside casing, for flooding due to a leaky boiler feed check valve which creates pressure in hurling water chamber.

(9) See whether the air vent strainer is clogged allowing pressure to build up in the hurling water chamber.

(10) See if noise occurs at a time of rapid acceleration of the motor with the receiver under a high vacuum.

(11) See if noise is the result of amplification due to resonance within the building or pump room.

(12) See that the pump is set level. If the pump is not level, the sleeve bearing motor shaft will rock back and forth.

(13) Observe if there is foaming in the hurling water chamber caused by oil from steam engine exhausts or excessive use of boiler compounds.

## Section VII. WATER LEVEL REGULATORS AND CONTROLS

### 4-31. General.

Water level regulators and similar equipment controls such as pump operation controls, consist basically of an enclosed float actuated valve, a switch, or a combination of both, mounted on the outside of the boiler to maintain a safe boiler water level. Regulators are arranged to serve some or all of the following purposes or combination of purposes:

*a.* Maintenance of minimum water level by cut-in of float actuated cold water make up.

*b.* Elimination of excessively high water level by opening of the float actuated overflow.

*c.* Maintenance of normal water level by cut-in and cut-out of the pump motor through float-actuated switch.

*d.* Stopping automatic stoker, oil burner, or gas burner by float actuated switch when water level is low.

### 4-32. Installation.

A satisfactory water level regulator installation for a conventional steam heating system consists of a mechanical boiler water feeder to maintain a minimum water level and an electrical low water cutoff to stop the boiler's automatic firing devices in the event of a low water condition. The unit is mounted at the low safe water level of the boiler. Since most manufacturers clearly mark the regulator body to indicate the water level maintained by the unit, the unit is normally installed below the normal operating level of the boiler in such a manner that the water line mark on the regulator body coincides with the low safe water level in the boiler. This is shown in figure 4-20. In addition to the combination feeder cutoff shown, steam boilers require a second low water cutoff independent of the first, with its own set of drum connections for blowdown valving and piping.

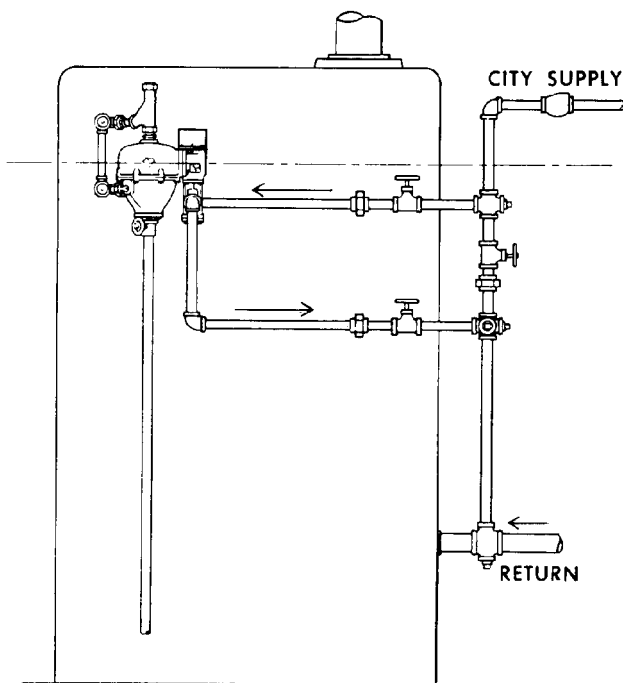

Figure 4-20. Water level regulator connections.

#### 4-33. Initial operation and servicing.

a. The mechanical feeder maintains a safe minimum boiler water level, as recommended by the boiler manufacturer. In an emergency situation where boiler level drops approximately  $\frac{3}{4}$  inch below the safe minimum level, the electrical low water cutoff switch stops the boiler's automatic firing equipment. When boiler water level is restored to  $\frac{1}{2}$  inch above the emergency low water level, the cutoff switch restarts the automatic firing equipment and control is returned to the mechanical feeder. Water level controls and similar devices are installed so that the exact operating characteristics and setting locations of the equipment for the purpose intended by the manufacturer are obtained. Maintenance of the boiler water level with regulators depends upon the carrying of a correct and stable water level in the float control unit. The unit is connected so that internal circulation of the boiler steam and water flow will not cause a false or fluctuating water level in the float body.

b. After prolonged shut down, fill boiler to within 6 inches of normal water level. Open feeder connections and note the rise of the water level and shut-off level of the feeder. The shutoff level of the feeder should be at the low safe boiler water level. Fill the boiler to the normal level plus enough water to fill the system with steam. For a quick check of the feeder, open the feeder drain valve for a few

seconds. If the feeder is in proper operating condition, flow of makeup water should be immediately observed.

#### 4-34. Operation and maintenance.

Clean and blow off dirt and scale in feeders as required by manufacturer's instructions or if required by poor water condition. To blow down units, close valves in the top and bottom connections to the boiler and open the blowoff valve. Keep the blowoff valve open until the water flow is clear. Do not open the feeder or water line controller connections to a new boiler installation until the boiler and system have been thoroughly cleaned. It is also necessary to check electrical connections and float elements.

#### 4-35. Typical operating difficulties.

A boiler can have too much or too little water for many reasons. If a boiler is equipped with an automatic boiler water feeder and water level is not maintained correctly, do not assume that the feeder is faulty. Figure 4-21 shows a typical cold-water piping hook-up to the feed valve of a boiler-water feeder. Follow the procedure below if the boiler water level cannot be maintained.

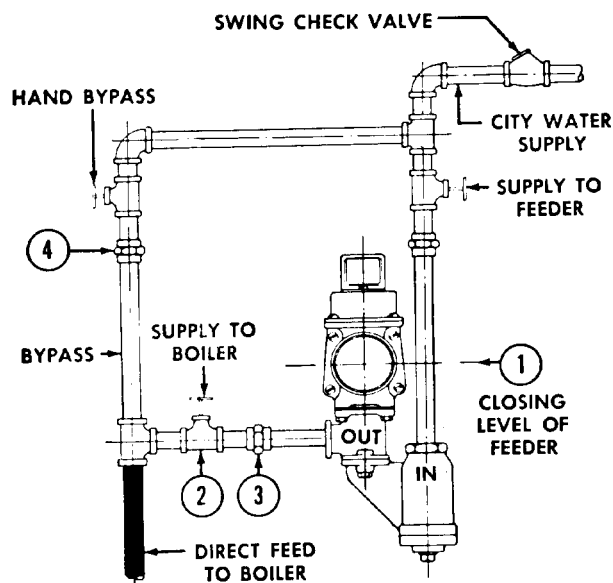

Figure 4-21. Boiler water feeder piping connections.

a. Make a broken union test for checking feeder operation.

(1) Make sure water in the boiler is above the closing level of the feeder.

(2) Close Valve 2 (figure 4-21) in the direct feed pipe from the feeder to the boiler.

(3) Break Union 3 between the feeder and Valve 2.

## TM 5-642

*b.* Check to see if the boiler is getting too much water.

(1) If water trickles out of the broken union from the feeder valve:

(*a*) Open and close the water feeder valve

manually several times. (See figure 4-22.) This should remove any obstruction from the water feeder valve seat, and the valve should drive itself to a driptight closure.

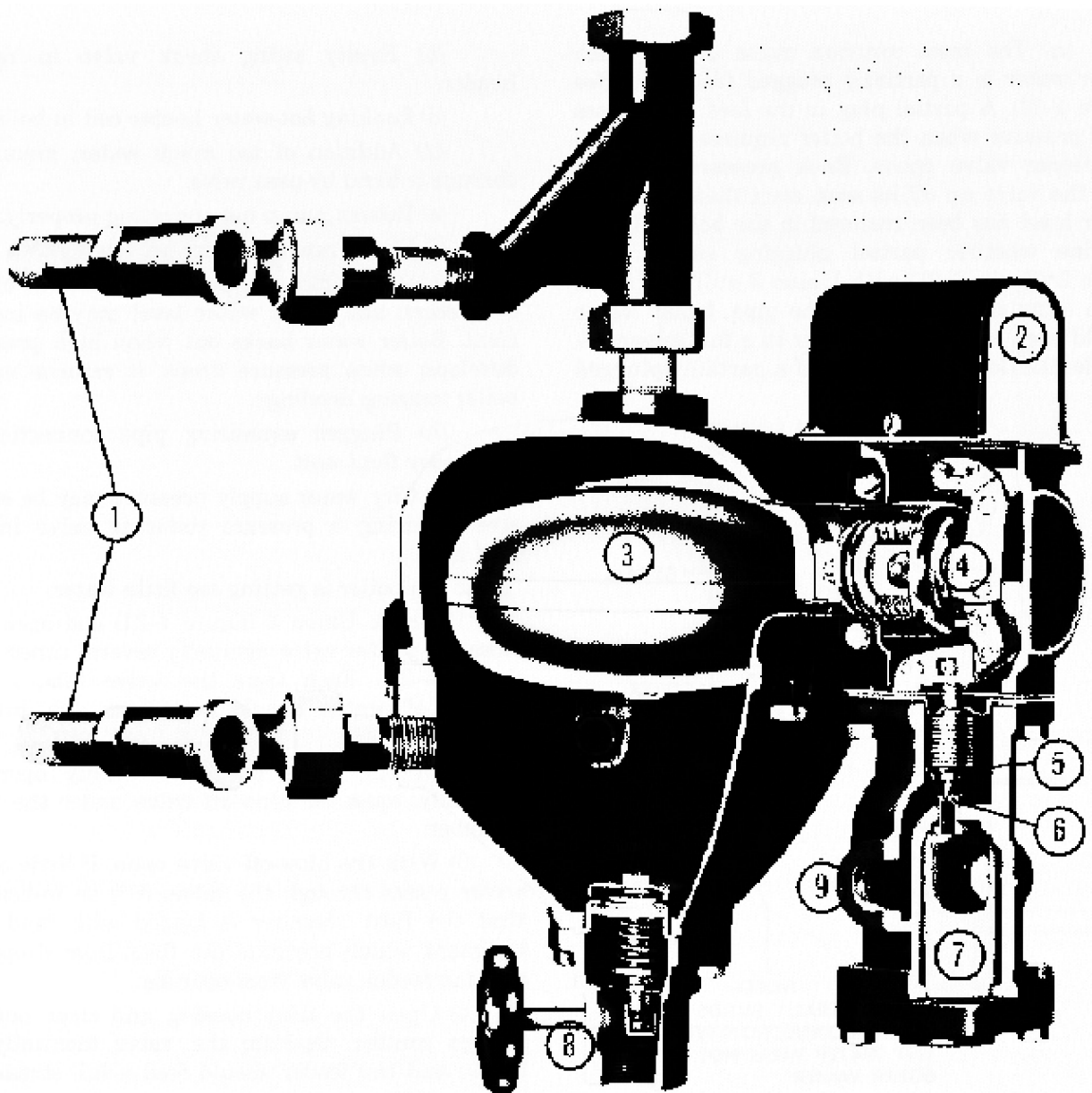

- |                              |                               |
|------------------------------|-------------------------------|
| 1. CONNECTIONS TO BOILER     | 6. WATER FEEDER VALVE SEAT    |
| 2. ELECTRICAL CUT-OFF SWITCH | 7. STRAINER BASKET ASSEMBLY   |
| 3. FLOAT                     | 8. BLOW-OFF VALVE             |
| 4. SYLPHON ASSEMBLY          | 9. BOILER WATER SUPPLY OUTLET |
| 5. WATER FEEDER VALVE DISC   |                               |

Figure 4-22. Boiler water feeder details.

(b) If manual operation of the valve does not eliminate leaking, remove and repair the valve or return the valve assembly to the manufacturer for replacement.

(2) If no water trickles from the broken union, the feeder operation is not the cause of flooding and a further check must be made to trace trouble.



(a) The most common cause of too much boiler water is a partially plugged feed line. (See figure 4-23). A partial plug in the feed line causes back pressure when the boiler requires water and the feeder valve opens. Back pressure tends to hold the valve up off its seat, even though normal water level has been restored in the boiler. To determine whether partial plugging exists, open Valve 2 (figure 4-21) with Union 3 still broken. If there is no swing check in the pipe, boiler water should back out from the boiler in a full stream. A trickle-like flow will be proof of a partially plugged pipe.

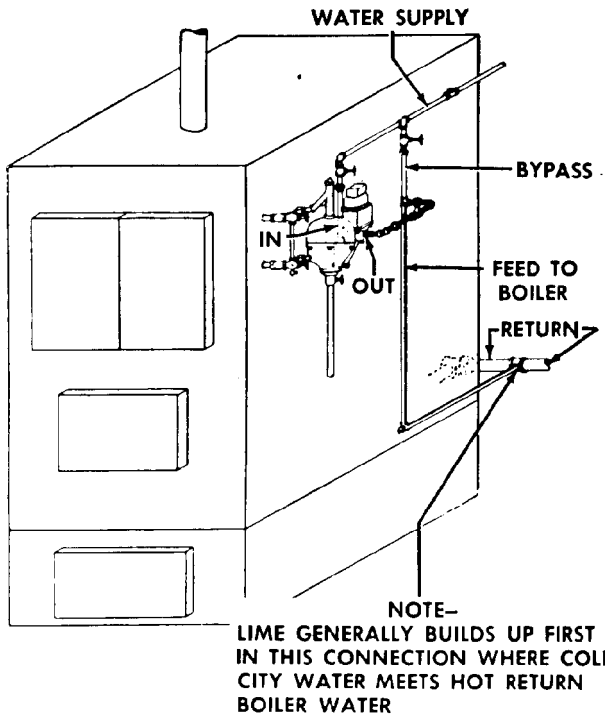

Figure 4-23. Stoppage area in boiler connection.

(b) Another common cause of flooding is a leaky hand bypass valve. Break Union 4 (figure 4-21) with the bypass valve closed. If water leaks out of the union, install a new globe valve.

(c) When boiler water feeders are piped up with 1 inch equalizing pipes, flooding of boiler may be caused by a faulty piping hook-up. Connecting the equalizing pipe from the bottom of the feeder chamber into the return header or bottom of boiler, or running a direct feed pipe into the equalizing line, will cause flooding.

(d) Closing level of the feeder on heating boilers should be set about 2 to 2½ inches below normal boiler water line.

(3) Other common causes of excessive boiler water are as follows:

- (a) Dirty boiler water.
- (b) Faulty swing check valve in return header.
- (c) Leaking hot-water heater coil in boiler.
- (d) Addition of too much water, manually, through a hand by-pass valve.
- (e) Return pump not operating properly.
- (f) Firing rate of burner set too high.
- (g) The difference between the level of the dry return and boiler water level may be insufficient. Boiler water backs out when high pressure develops; when pressure drops, it returns to the boiler causing flooding.
- (h) Plugged equalizing pipe connection to the feeder float unit.

(i) City water supply pressure may be excessive requiring a pressure reducing valve in the feed line.

c. If the boiler is getting too little water:

(1) Break Union 3 (figure 4-21) and open and close the feeder valve manually several times. (See figure 4-22.) Each time the valve lifts, a full stream of water should run from the broken union.

(2) If the valve cannot be easily operated manually, open the blow-off valve under the float chamber.

(3) With the blow-off valve open, if little or no water passes through the valve, it is an indication that the float chamber is loaded with mud and sediment which prevents the float from dropping and the feeder valve from opening.

(4) Open the float housing and clear out all foreign matter. Operate the valve manually as before and the feeder should feed a full stream of water.

(5) The broken union test may show that the feeder is in good condition but still does not feed water into the boiler. The feedline shown in figure 4-23 may be fully plugged, especially where the connection is made to the return header or bottom of the boiler.

(6) If little or no water comes through the feeder valve when operated manually, remove and clean out the strainer. The strainer may be filled with sediment which prevents water from getting to the feeder.

(7) Other common causes for insufficient water in the boiler are:

- (a) Priming and foaming due to dirty boiler water.
- (b) Excessive pressure difference between supply and return piping preventing condensate return to boiler.

(c) Faulty operation of the boiler feed pumps.

(d) City water pressure less than boiler steam pressure.

## Section VIII. BOILER TRIMMINGS, GAUGES AND POP SAFETY VALVES

### 4-36. General.

Many newly installed glasses are broken by turning water onto them carelessly. A piece of screen mesh or canvas may be used as protection against breaking glass. For installing and replacing glasses the following suggestions are considered good practice.

### 4-37. Gauge glass breakage.

A brittle and improperly cooled glass breaks easily. Purchase only the best glass. Long glasses break easily; glasses no longer than 12 inches are preferable.

### 4-38. Installing gauge glasses.

*a.* Fuse cut ends since glasses are weakened by broken surfaces.

*b.* Place glass connections in perfect alignment and free from strain on glasses. Jamming or twisting glasses when tightening the stuffing box nuts causes breakage.

*c.* Gauge glasses are broken easily if scratched. Exercise great care in storing.

*d.* Gauge glasses should be protected from an accidental blows. Provide rods or other means of guarding the glass.

*e.* Open and close all cocks slowly.

*f.* Wear goggles during this phase of installation. Remove all broken pieces. Open valves slowly and blow out any debris taking care to turn face away. Make sure new glass is of the proper length, that the drain is open and connections are lined up. Insert glass, but do not set up too tight. Replace the guard if cocks must be opened and closed near the position of the glass or cannot be operated from the floor.

*g.* Open the top valve slightly and warm glass by allowing a little steam to pass through so that heat is evenly distributed over the entire column. If water is admitted first, uneven heating may break the glass. When the water level appears steady, open the bottom valve wide and then open the top valve wide. Always test the water glass when replacement has been made. This should also be done when the boiler is placed in service and when difficulty is experienced with foaming or priming.

### 4-39. Testing and care.

Keep all lines and valves between the water column glass and the boiler clear. When it is difficult to read the level because of a foreign substance in the tube, replace the glass. Do not clean a glass while it is in place.

### 4-40. Steam pressure gauges.

*a.* Connect at least one gauge with gauge cock and siphon to each boiler and keep it in good condition to indicate steam pressures accurately.

*b.* Keep gauge dials and glass covers clean and well lit to permit easy reading at any time.

*c.* Test and reset pressure gauges as required by manufacturer's instructions or when readings appear abnormal.

*d.* Installation of suitable connections to each boiler for inserting a test gauge is of great assistance. Install a tee connection on the gauge line so that a standard test gauge may be used to check the condition of an indicating gauge.

*e.* Never admit steam directly to the gauge. If steam is admitted to the gauge, the gauge should be retested. Be sure the siphon is properly filled with water at all times.

*f.* Steam gauges on a battery of boilers should be graduated alike and should be of the same type.

### 4-41. Safety valves.

*a.* Never operate a boiler without one or more safety valves of sufficient capacity as indicated by the ASME Code. Keep those valves free and in working order at all times.

*b.* Never place a stop valve between the boiler and a safety valve.

*c.* Test the safety valve periodically by lifting the valve off of the seat by hand. This should not be done unless the boiler pressure is from 80 to 85 percent of the present popping point. Under no condition attempt to prevent safety valve leakage by tightening the spring.

*d.* When a safety valve does not pop at the required pressure, check carefully to determine the cause. If the faulty valve condition cannot be corrected, replace the valve.

*e.* Set safety valves in accordance with ASME Code requirements to pop at the proper pressure, blow to reduced pressure, and close without chat-

tering or simmer. All safety valves should be properly sealed after being set.

**4-42. Blow-down pipes.**

Maintain all valves, cocks, and lines carefully and inspect regularly for defects. Where leaks are discovered, make repairs as soon as practicable. Examine discharge end of blowoff pipes for indication

of leaky valves. Discharge ends of blowdowns should be open for inspection at all times.

**4-43. Dampers.**

Inspect all dampers for looseness and other defects before boiler is placed in service. Examine dampers periodically and keep in good condition.

**Section IX. TRAPS**

**4-44. General.**

The basic purpose of a trap is to discharge condensate, entrained air, and other gases from a steam area, while preventing or minimizing loss of steam. Various types of traps in use are: bucket, thermostatic, combination float and thermostatic, and thermodynamic traps. For steam heating systems, the thermostatic, or combination float and thermostatic (F&T) are most commonly used.

**4-45. Thermostatic traps.**

Thermostatic traps are varied in design detail but are classified as bellows or diaphragm type based on the kind of expansion element used. (See figures 4-24 and 4-25).

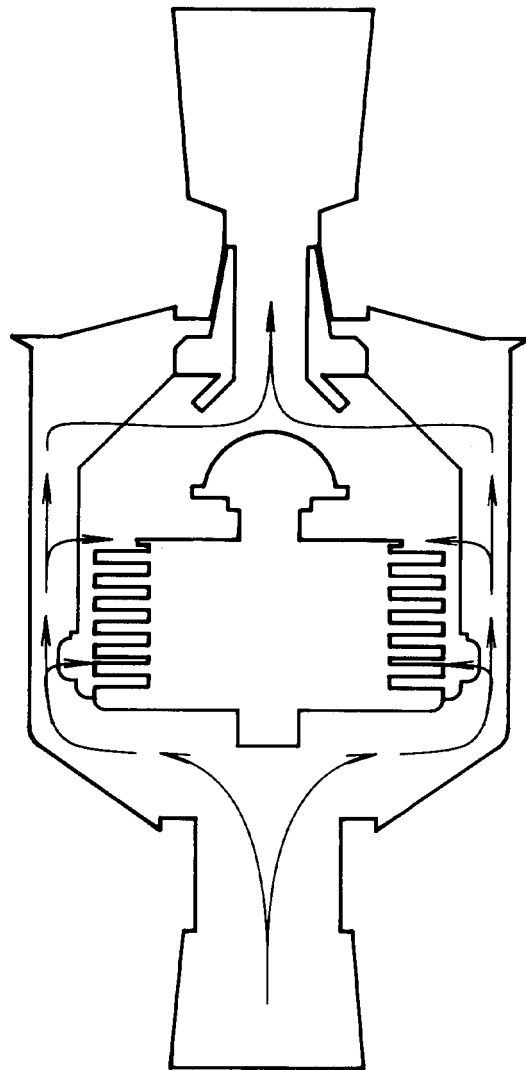

*Figure 4-24. Thermostatic trap (bellows type).*

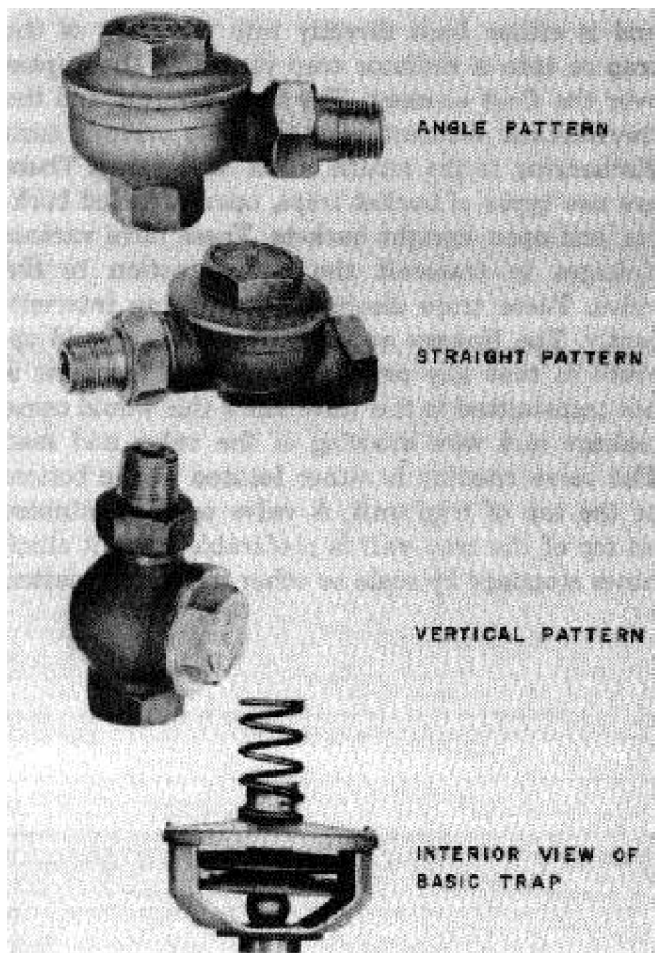

Figure 4-25. Thermostatic traps (diaphragm type).

*a. Installation.*

(1) It is important to install traps so that the trap inlet is at or below the steam chamber and to connect the discharge opening to the return piping so that condensate will return by gravity to the steam main. Thermostatic traps do not lift or siphon condensate from a steam radiator. The top water line of a trap should be the top water line in the steam space served by the trap to ensure proper condensate drainage. Lower heat emission and efficiency of a heating unit may result due to partial filling of the steam space by water which is backed or held in the heating unit by a clogged or defective trap or a trap set too high.

(2) The thermostatic trap is set so that the axis of the bellows or diaphragm is vertical to assure that the thermostatic element is not partly immersed in condensate.

(3) The return pipe connections should be arranged so that expansion and contraction of the mains does not place strains on the trap.

(4) After the heating system piping, boilers and other equipment are cleaned and in operation, shut

each radiator valve and remove the cap of each thermostatic trap after the thermostatic unit has cooled. Do not open thermostatic traps when they are hot or when high vacuum is present in the returns, since permanent distortion may occur to the diaphragm or bellows. After the cap is removed clean the trap interior, valve, and seat carefully with a clean cloth. Do not clean seats, valve discs or heads with abrasives, emery cloth, or files as permanent scoring may result. It is important to clean the trap during initial periods of new plant operation as often as necessary and also immediately following the shut-down of the heating system for summer lay-up.

(5) When removing caps, use wrenches furnished by the trap manufacturer to avoid damage to heads and caps. Before replacing caps, carefully wipe the threads clean and coat lightly with oil.

*b. Maintenance.*

(1) Clean the interior of thermostatic traps, including diaphragm, valve seat and heads as required by manufacturer's instructions or as often as required if water conditions cause excessive deposit of solids, greases, or scale.

(2) A simple inspection check of the diaphragm or bellows is accomplished by shaking the diaphragm near the ear. Note by sound whether or not the diaphragm contains liquid. Pull the valve head to expand the thermostatic element slightly and then compress to detect the sound of air or liquid leaks. If the diaphragm or bellows leaks, it must be replaced with a new element. Do not refill diaphragms, or patch and solder leaks, since charging and closing thermal elements requires a factory process with exact procedures and exceedingly close tolerances.

(3) If the valve head is damaged or scored, remove it from the thermal element and replace it if possible; otherwise, install a new diaphragm or redress with special tools which are available from the trap manufacturer. To regrind trap seats or discs, it is necessary to shim the diaphragm in re-setting, with shims available from the manufacturer to compensate for metal removed from the valve head or seat. Do not regrind or cut valve seats of the replaceable type, since the trap setting is disturbed by excessive removal of metal.

*c. Typical operating difficulties.* Faulty traps will cause readily discernible operating difficulties. Radiators will fail to heat due to air binding. This may be caused by clogged traps or burst diaphragms. Bellows expand on release of their internal vacuum and close the valve. Return lines become excessively hot due to cut valves and seats which allow excessive steam leakage into return mains. Radiators will pound or have considerable

water surging sounds when the trap lacks capacity, when trap is not properly set at the bottom of eccentric radiator outlet bushings, or when the trap is clogged. Defective traps should be returned to manufacturers for repair or replacement.

**4-46. Float and thermostatic traps and bucket traps.**

These traps are installed on high capacity heating units such as unit heaters, blast coils, and hot water supply heaters. F&T traps are also used to drip ends of steam mains of closed vapor and vacuum heating systems. F&T traps consist primarily of two elements: the float section which is intended to handle the condensate, and the thermostatic element which consists of a diaphragm or bellows unit to pass air and gases. (See figure 426). The thermostatic element is an exact duplication of the

thermostatic element of a radiator trap and is either built directly into the body of the trap or into a radiator trap placed in the bypass over the float element. The float element and the thermostatic element have separate orifices, each discharging to the return outlet of the trap. There are two types of bucket traps, open inverted buckets, and open upright buckets. These have various linkages to transmit the bucket action to the valve. These traps discharge condensate intermittently. The linkage or leverage system should operate so that any pulsating action of the float is not transmitted to the valve since this would cause leakage and wire drawing of the valve and seat. The valve opening is either located at the bottom or the top of trap unit. A valve opening situated on top of the trap unit is preferable since it eliminates stoppage by scale or other entrained matter.

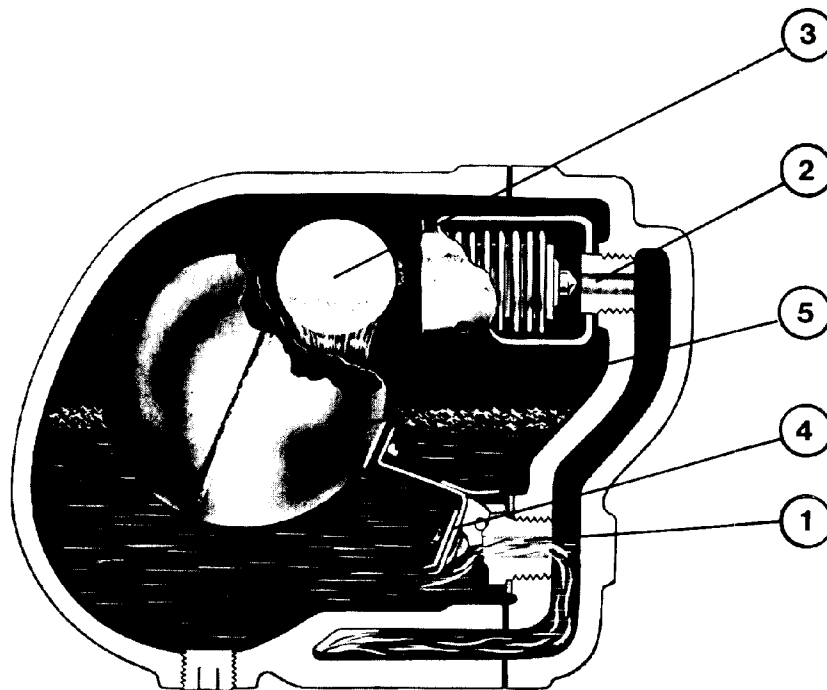

1. CONDENSATE DISCHARGE PORT
2. THERMOSTATIC AIR VENT
3. CONDENSATE INLET
4. CONDENSATE DISCHARGE VALVE
5. FLOAT

Figure 4-26. Float and thermostatic (F&T) trap.

*a. Installation.* Float traps will not siphon or lift condensate. The float trap must be installed so that the top water line of the trap is below the bottom of the equipment to be drained. The float trap must be set level to eliminate binding of the leverage system. Trap connections at the end of mains should include a shut-off valve, vertical drop or dirt pocket, strainer, and finally a drop into the return main. The bottom of the dirt pocket should be fitted with an easily removable cap for blowdown and removal of dirt, scale, and grease. Float traps installed on unit heaters or

other equipment which have readily accessible steam shutoff valves at the supply connection, need not be provided with shutoff valves.

*b. Operation and cleaning.* After completion of replacement, remove any temporary blocks or ties which are present to hold the float mechanism during shipping and installation. If the trap is equipped with a priming plug, open and fill the trap with water. If a priming plug is not provided, open the valve to the steam line or heating unit supply valve and allow the trap to prime as condensate accumulates in the body. This process may entail a

short period of steam leakage. Open caps of strainers and dirt pockets preceding traps at frequent intervals, or as indicated necessary, to assure removal of any accumulation of grease and scale. After traps have been in service on new installations for a short period, remove covers, valve head and seat, and wipe the internal mechanism thoroughly with a clean cloth to remove initial grease, scale, and accumulations of core sand. Periodic opening of the trap drain plugs and blowdown is effective in maintaining good trap service.

*c. Maintenance.* Check traps frequently to be sure that they are operating properly. A correctly operating trap has a definite open and closed position, and the sound of condensate flow and shutoff can be detected easily by listening closely at the discharge piping of the trap. Use a stethoscope to check trap operation. Holding the stethoscope to the trap body in the area of discharge provides a satisfactory method for checking trap performance. Repair or replace a trap immediately upon detection of blowing steam. This condition disrupts functioning of the heating system and further damage to the trap will result because of the cutting action of wet steam and condensate flowing through a scored or restricted opening. Blowing or leaking traps will also cause excessively hot returns. Inspect operating elements periodically; float failures or leakage of the ball or other closed type floats closes the valve and causes backup of condensate. Failure of an upright open bucket trap element results in blowby but not in backup of condensate. This failure is safe since backup of

condensate could result in freezeup of extended surface coils used in ventilating work and of other steam units exposed to ambient conditions. Keep a shop supply of serviced traps for quick replacement so that equipment need not be shut down during repair operations.

*d. Typical operating difficulties.*

(1) Steam leakage or blowby is the most common difficulty and is caused by float failures, a worn linkage or lever system, cut valves, or excessive accumulations of dirt, rust, scale, and grease.

(2) Pounding and noise (water-hammer) in a heating unit or steam main indicates backup of condensate due to inadequate trap capacity. Steam traps should be sized for 250 percent of the heating unit capacity to permit excess condensate removal during cold start-up. Noise is also caused by clogged traps or defective or jammed float mechanisms.

(3) Air binding due to failure of the thermostatic element causes heating equipment failure and is usually detected by a relatively cool area preceding the trap. Air binding creates an air pocket which prevents steam from filling the steam space of the heating unit and the top of the trap. When this condition is present, backing off the thermostatic element cover or opening the cleanout plug will result in a rush of air followed by a rush of condensate and steam. To correct this condition, service the thermostat unit which may be either clogged or closed by a ruptured thermostatic element.

## Section X. AIR VENTS

### 4-47. General.

Air vents installed on radiators and ends of mains of gravity heating systems consist of a combination thermostatic and float actuated valve stem and orifice, usually housed in a sealed casing. Some air vents include an adjustable orifice to increase or decrease the vent rate, which provides for balancing of the heating system.

### 4-48. Installation and operation.

Vents, when installed on radiators, are located at the end opposite the steam connection. Radiators for use with steam and hot water often have two vent tappings, one near the top and the other approximately one third of the way down from the top. The lower opening is used for steam systems, since this is the location at which air will pocket between the top and bottom radiator section connections. The top opening is used to vent the radi-

ator in hot water systems. Vents at ends of steam mains, unit heaters, and the like are usually of the vertical straight shank type and are installed at the top of a vertical pipe extension. The usual type vent is sealed so that on-the-job repair is not practical. Therefore, when placing a vent in initial operation, be careful not to force or inject excessive amounts of grease or scale into the vent.

### 4-49. Maintenance.

Remove vents from the system during the off-heat season and allow to soak in a container of kerosene for approximately 24 hours to loosen rust and grease; then place in a vertical position, drain thoroughly, and allow to dry. Air pressure is very effective in blowing out vents following the kerosene soaking process. When using air pressure for removing dirt, use proper goggles for eye protection.

**4-50. Typical operating difficulties.**

The most apparent failure occurs when a vent spouts water and steam caused by dirt on the valve or opening, by failure of the thermal element or by a bent connection in a water pocket of the piping system. A clogged vent could result in air binding which would prevent steam from entering the

heating unit. If unsatisfactory vent performance cannot be corrected by cleaning procedures, replace the vent. Manufacturers usually maintain a repair service; consult the manufacturer for details of factory servicing of vents when a quantity of defective units have accumulated and repair is beyond the scope of local repair facilities.

**Section XI. STEAM RADIATORS****4-51. General.**

There are two types of radiators: cast iron and extended surface units. Extended surface units are made up of relatively small tubes onto which metal fins are formed. The tubes of extended surface units are either continuous or set in headers and the tube element is placed in a metal cabinet or enclosure with circulating grilles at the top and bottom.

**4-52. Installation.**

It is extremely important that radiators pitch toward the condensate discharge opening, particularly if the radiator is of the extended surface type. Radiator traps applied to extended surface radiators must be in perfect operating condition; slight holdup of condensate will greatly reduce the effectiveness of this type of heating unit which has relatively small available steam space. Traps of extended surface radiators are placed at an elbowed down connection, so that the trap is below the steam space to facilitate cleaning. Swing-through double-elbow joints should be used and ample length in supply and return branches to radiators should be provided so expansion and contraction of mains will not cause breakage of radiator connections. Cast iron radiators require a firm setting on solid

flooring; legless radiators are firmly fixed to wall brackets. Radiators are normally installed directly under windows or at outside walls to offset transmission and infiltration losses and provide comfortable room conditions. Reflectors can be provided behind radiators to get maximum heat output, covering them should be avoided.

**4-53. Initial operation and cleaning.**

After new radiators have been in service for a short time, open and clean out thoroughly through the return opening. Clean the outside of radiators frequently to maintain maximum heat output.

**4-54. Typical operating difficulties.**

Failure to heat due to stoppage or defective piping causes radiator operating difficulty. Air binding will also prevent radiators from heating properly. See Section X on air vents. If radiators heat but no rise occurs in room temperature, calculate the room heat loss and compare it with the quantity of installed radiation. Reduce heat loss, if possible, by stopping cold air leaks through cracks, doors, and windows of the area being heated. If radiator output is still insufficient, relocate radiation units or install additional units.

**Section XII. STEAM UNIT HEATERS****4-55. General.**

Unit heaters consist primarily of an extended surface steam coil and a propeller or blower fan which creates rapid flow of air through the heating coil. The basic types are horizontal and vertical discharge from ceiling suspension (figures 4-27 and 4-28) and floor mounted horizontal blower units (figure 4-29). Units are rated in BTU per hour or equivalent direct radiation (EDR) heat output and cubic feet per minute air discharge capacity at given motor or fan speeds. These ratings are important in application of unit heaters. The area effectively heated by the unit is reduced as the elevation of the

unit is increased. It is preferable to set the horizontal discharge to blow toward an outside wall at a large angle and to discharge all units in the same direction to form a continuous circuit of air around exposed walls. Units placed in small rooms with low ceilings may be located on outside walls with a recirculating duct to the floor to provide even heating effects without undue draft conditions. Vertical discharge units are usually placed at room ceiling or structural members and, since they discharge directly downward, appropriate diffusing type outlet nozzles are used to eliminate drafts or hot spots at the floor level.



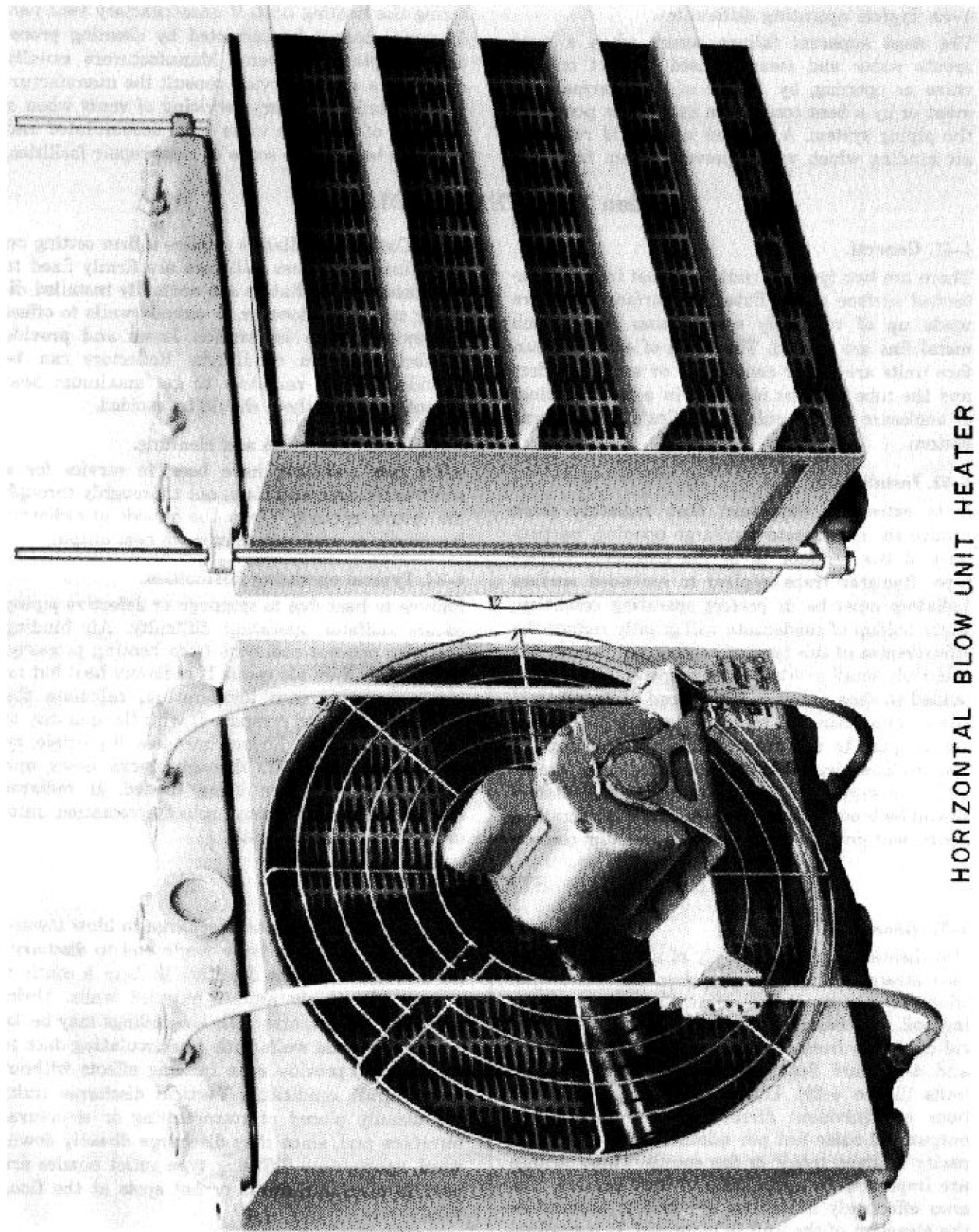

Figure 4-27. Horizontal-blow unit heater.

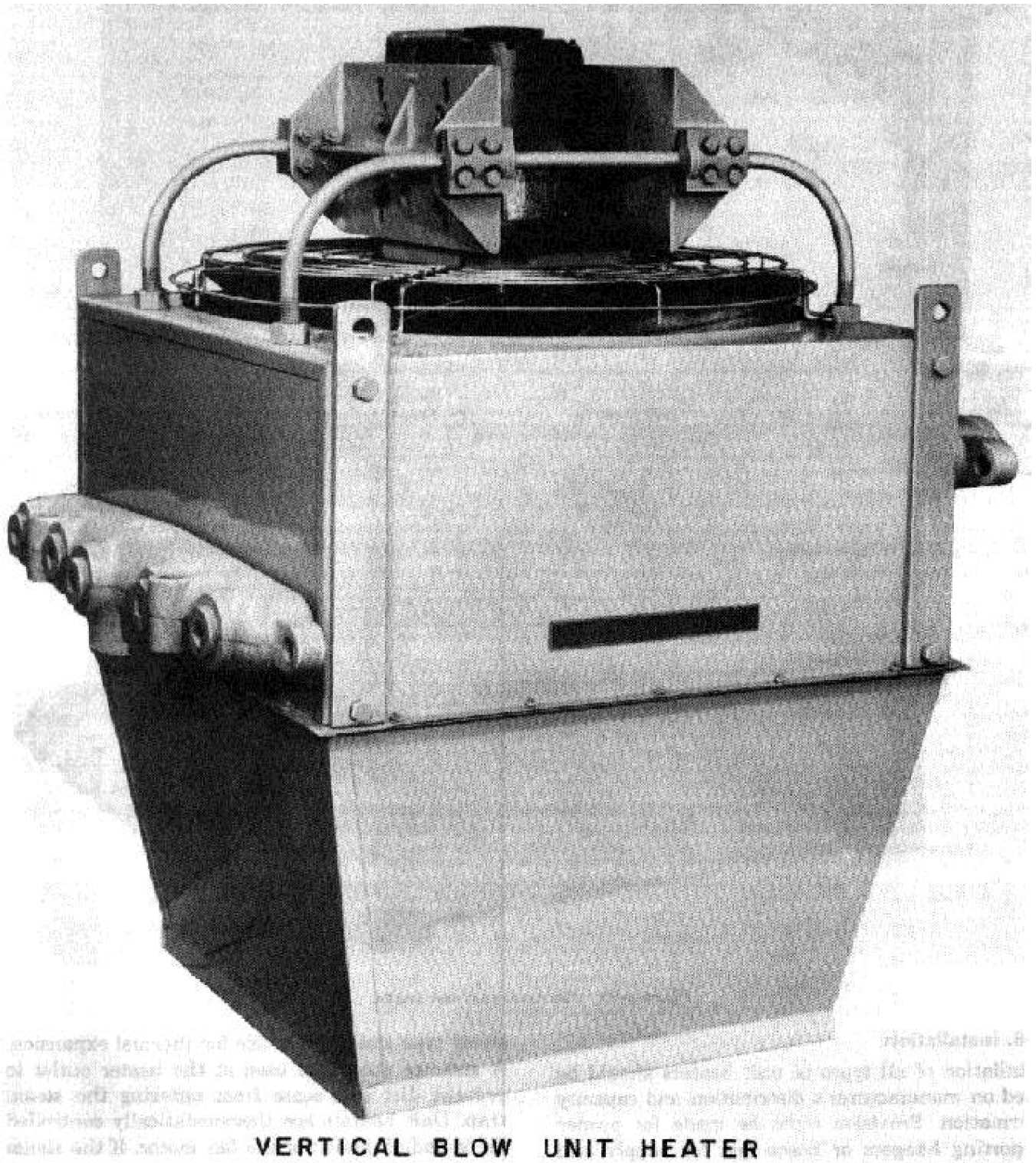

Figure 4-28. Vertical-blow unit heater.

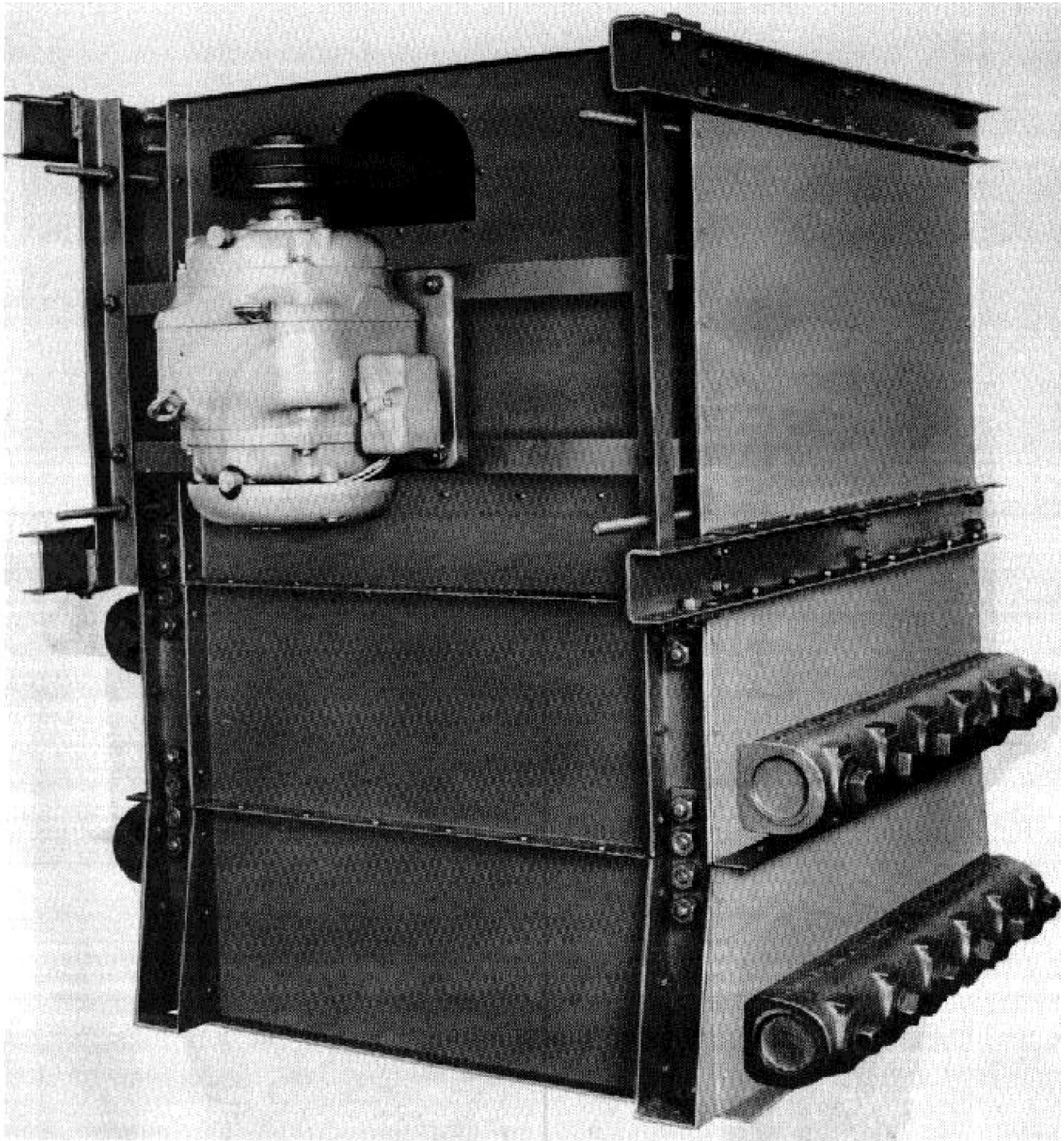

Figure 4-29. Floor mounted unit heater.

**4-56. Installation.**

Installation of all types of unit heaters should be based on manufacturer's distribution and capacity information. Provision must be made for proper supporting hangers or bases and for supply and return branch connections with ample pitch and drop. Steam piping should have double elbow swing type joints to provide for thermal expansion.

A strainer should be used at the heater outlet to prevent dirt and scale from entering the steam trap. Unit heaters are thermostatically controlled by on-and-off action of the fan motor. If the steam system has periods when no steam is supplied, thermostatic controls include a reverse acting immersion or surface aquastat or a pressurestat which permits operation of the unit heater only when steam is

available. When starting a cold heater, condensate forms rapidly at rates beyond normal heater capacity. Therefore, adequate drop shall be provided between the heater outlet and connection to the return main, and a trap of sufficient capacity should be provided to handle the initial condensate flow. If the piping system is of the two-pipe open return type without traps, the unit heater coil is vented adequately by extending a vertical pipe from the point at which the unit return branch drops to the return main. An air vent is placed at the top of the vertical extension and should run to a point above the top of the heater.

#### 4-57. Maintenance.

Check electrical connections and contacts periodically, lubricate bearings, and clean out piping connections and strainer. Clear the outside of the steam

coils as required. Replace fan guards on unit heaters after maintenance.

#### 4-58. Typical operating difficulties.

Spaces may fail to heat satisfactorily even though the unit heaters appear to be hot and steam is available. Check the unit heater motor and fan speed to be sure that heated air is passing through the unit in sufficient quantity to provide the required capacity. If units are delivering their design capacity, check the space heat loss, and check to see if the location of the heaters is proper. There are horizontal and vertical distance limits which affect the performance of unit heaters. Review manufacturer's literature to determine if the heating failure is due to excessive height or distance between units. Failure of units to fill with steam is usually due to failure of the air venting device, clogged piping or inadequate trap capacity.

### Section XIII. STEAM HEATING COILS

#### 4-59. General.

*a.* Extended surface coils similar to those used in unit heaters, but of considerably greater capacity and physical dimension, are used extensively in heating air for fan blast heating systems and ventilation systems. Coils usually consist of non-ferrous tubes onto which fins are forced to provide large surface area. Steam heating coils are of four general types:

(1) Serpentine coils are used for small steam heating jobs with low air quantities where there is no possibility of the coil freezing. In these coils the steam is introduced at the top where it flows in a serpentine manner to the outlet at the bottom.

(2) On larger installations header type coils are used where steam is introduced into a large header which feeds a number of small tubes in parallel. The steam may then make one or more passes to a return header which collects the condensate and is provided with a connection at the bottom which is piped to the steam trap.

(3) Another type of coil uses a small perforated tube nested within a larger tube. The steam enters a header into which a number of these tube assemblies are connected. The header is split and arranged so that the steam flows into the inner tube and the condensate flows around the inner tube, back to the condensate portion of the header to be drained away. The design purpose is to keep the condensate warm so that it will not freeze. The original selection of the name "non-freeze" coil was unfortunate because too many have experienced

freeze-up, usually because of failure of the trap to drain the condensate.

(4) On all of the above types of steam coils the control is by means of a thermostat modulating the steam flow to the coil to match the load. A fourth type of coil is the face and bypass coil where steam is delivered to a top header and condensate removed from a bottom header. When in operation the steam is on at full pressure and control is obtained by means of the thermostat operating face and bypass dampers around each tube. Properly installed, this coil is the least subject to freeze-up on 100% outdoor air installations.

#### 4-60. Installation.

Provision must be made for ample support and ample pitch to assure quick drainage of condensate. Ample pitch is particularly necessary when long coil are used, since the cross-sectional area of each tube is small. Small quantities of condensate formed due to lack of pitch will reduce the heating capacity considerably. The discharge or return connection should be dropped approximately 12 inches before entering the trap to ensure proper drainage. Large slugs of condensate from cold units are handled by traps of adequate capacity. Long coils are tapped for air venting and provided with auxiliary air venting units and vacuum breakers when required. Manufacturer's piping details indicate tappings to be used for steam supply, condensate return, air venting and general installation requirements.

**4-61. Initial operation and cleaning.**

Clean the steam system piping before connecting heating coils to the system, since small amounts of oil, grease, or core sand can close tubes of extended surface radiation completely. Drain and blow out coils periodically to eliminate stoppages due to accumulated foreign material.

**4-62. Maintenance.**

Service traps and adjust steam supply controls to assure complete filling of coil with steam and rapid removal of condensate. Maintain the air side of coils in a clean condition to maximize heat transfer.

**4-63. Typical operating difficulties.**

Complete or partial failure of the coil to heat properly can be caused by lack of sufficient steam pressure, faulty operation of the inlet control valve, or defective traps, vacuum breaker or air vents. Improper pitch results in greatly reduced heat output. Failure of the coil to heat properly may also be caused by a restriction in airflow caused by a dirty coil, dirty filters, or a restriction in the ductwork. Improper fan speed will also reduce the amount of air going through a coil which reduces the coil output.

**Section XIV. STEAM HUMIDIFIERS**

**4-64. General.**

*a.* To ensure the advantages steam affords over other humidification media, the humidifiers employed must provide three essential performance characteristics: conditioning, control, and distribution. The humidifier must condition the steam to be completely dry and free of significant particulate matter. It must respond immediately to control and provide precise modulation of the output. Finally, it must distribute steam as uniformly as possible into the air. Direct steam humidification can be used only when the steam supply does not contain toxic chemicals such as amines. Heat exchangers should be used whenever there is any question about the quality of the steam.

*b.* Proper location, installation, and control of humidifiers are essential to achieve totally satisfactory, troublefree performance. The primary objective is to provide the required humidification without dripping, spitting, or condensation. Moisture, even in the form of damp spots, cannot be tolerated in the system. Aside from the hazard to the structure caused by water in the ducts, there is an even more critical health hazard if breeding grounds are provided for bacteria.

*c.* Steam must be discharged as uniformly as possible into the air to permit the fastest possible absorption without creating damp spots or saturated zones. In normal ducts, a single distribution manifold installed across the long dimension will provide good distribution of steam. In large ducts or plenum chambers, it may be necessary to broaden the pattern of vapor discharge to achieve the required distribution, thus requiring multiple manifolds from a single or from multiple humidifiers.

*d.* Humidification for areas not having central air handling systems is customarily achieved with unit

humidifiers discharging steam directly into the space. Proper mixing of the steam with the air is accomplished by use of a dispersing fan mounted on the humidifier, or by installing the humidifier in conjunction with a unit heater, positioned such that the air flow from the heater absorbs and distributes the water vapor.

**4-65. Installation of duct type humidifiers.**

*a.* Horizontal manifolds should be perfectly level with the discharge holes pointed upstream against the air flow. Manifolds over one foot in length should be supported. The humidifier body is normally suspended by straps or mounted on brackets, and should be mounted right at the duct or fan housing.

*b.* Steam supply and condensate drainage piping should be made in accordance with good piping practice. The use of multiple vertically-stacked manifolds from one or more humidifiers should be considered when any of the following conditions exist at the humidifier location:

- (1) If duct air temperature is below 65F.
- (2) If duct air velocity exceeds 800 FPM.
- (3) If high efficiency filters are located less than 10 feet downstream.
- (4) If the height of the duct section exceeds 36 inches.
- (5) If visible vapor impingement on coils, fans, dampers, filters, turning vanes, etc. located within three feet downstream of the humidifier would be objectionable.

*c.* Humidifier manifolds should be located according to the following guidelines:

- (1) Whenever possible, install the distribution manifold downstream from the coils. If there is more than three feet between the manifold and the coil on the upstream side, the manifold can be

installed at this location.

(2) When it is necessary to place the humidifier in the coil section ahead of the fan, locate the manifold in the most active air flow and as far upstream from the fan inlet as possible.

(3) When it is necessary to place the humidifier discharge into a packaged multizone air handling system, install the distribution manifold into the center of the active air flow and as close to the fan discharge as possible.

(4) Do not install a distribution manifold closer than 10 feet upstream from a temperature controller.

(5) The distribution manifold should never be placed within three feet of a fan inlet; the best location is at the fan discharge.

(6) Whenever possible, install the distribution manifold into the center of the duct.

(7) Always install distribution manifolds as far upstream from discharge grilles as possible, never less than three feet upstream.

(8) Always size and install the distribution manifold to span the widest dimension of the duct section.

(9) The manifold should never be installed vertically downward from the humidifier. This presents a condensate drainage problem in the jacket of the manifold. Vertical upward installation is permissible.

#### **4-66. Installation of unit humidifiers.**

Unit humidifiers are installed very much like unit heaters. They may be suspended from the ceiling or bracketed to a column in locations determined as best for achieving uniform distribution of water vapor. The humidifiers should be mounted high enough from the floor so that discharge clears personnel and far enough from the ceiling to prevent condensation; discharge should not impinge upon machinery, columns, light fixtures, piping, etc.

### **Section XV. PRESSURE REDUCING VALVES**

#### **4-67. Types.**

Space heating systems connected to a high pressure central heating plant and distribution system have pressure reducing valves which reduce the main pressure to low pressure heating service. There are many types of steam service reducing valves, including double-seated or single-seated, diaphragm-loaded or spring-loaded, or combination spring and diaphragm loaded, and many types of special pilot operated valves. The most applicable valve for reduction of 50 to 75 psig initial pressure down to 5 psig is the double-seated diaphragm-loaded type (figure 4-30). The diaphragm chamber is connected to the low pressure steam heating main by an equalizing pipe. The equalizing pipe is connected to the steam main approximately 10-15 feet from the valve at which point steam pressure is considered stabilized. Valve setting on the low pressure side is obtained by adjusting a system of

springs or by weights on a lever arm. Range of accurate reduction through a pressure reducing valve depends on the type of valve seat and power of leverage and control element. A double seated diaphragm and lever operated valve will provide satisfactory service to a maximum of 75 psig upstream pressure. A small amount of continuous steam leakage usually occurs through double-seated valves, since it is difficult to obtain two tightly seated disks on the same stem for use under varying temperature conditions. Therefore, in steam pressure reduction where tight shutoff is required, as in providing steam for kitchen equipment and sterilizers, a single-seated valve is used. Slight leakage of a double-seated reducing valve in heating system service is not serious since space is available for quick condensing and discharge through traps into the return system.

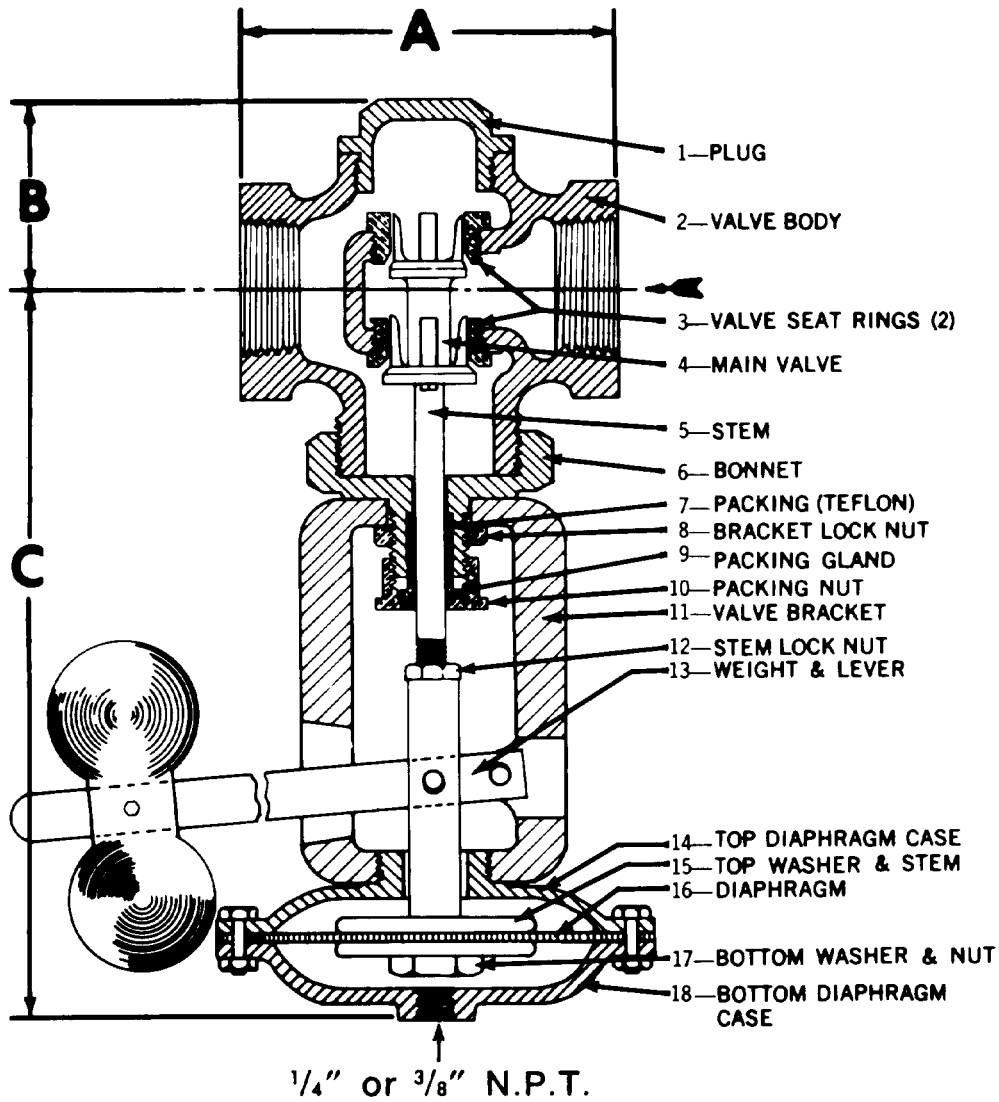
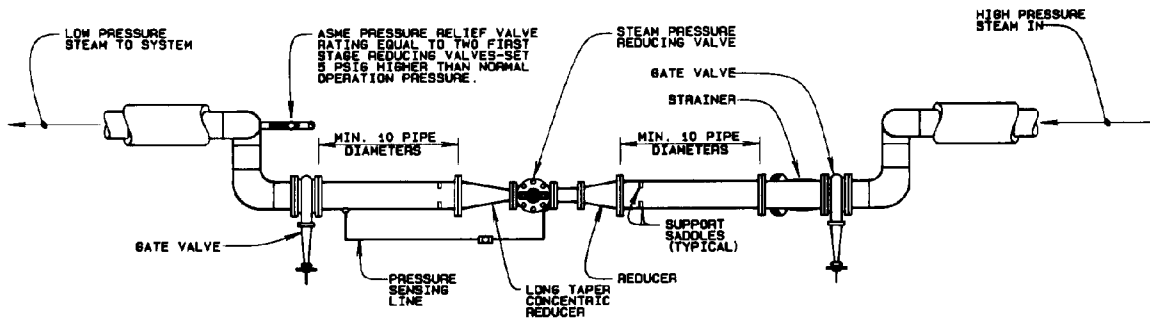

Figure 4-30. Double-seated diaphragm pressure reducing valve.

**4-68. Installation and initial operation.**

The branch leading to the pressure reducing valve (PRV) is a top connection from the main steam line. Every precaution should be taken to ensure delivery of clean, dry steam to the valve. The reducing valve installation includes a strainer ahead of the valve, a globe valve ahead of the discharge, and a gate valve in the discharge; all are bypassed by a line one size smaller than the pressure reducing valve. (See figure 4-31 for a typical PRV schematic arrangement.) Generally, a straight-through size provides more satisfactory steady pressure reduction than an expanded outlet valve, giving a more stabilized interior operating condition. A typical low pressure diaphragm valve is installed so that the diaphragm is below the valve. The diaphragm chamber is connected to low pressure

steam main by a 1/2 or 3/4 inch pilot line which connects to the main at a point not less than 10 feet from the valve. Pilot lines are valved at the connection to the main, and contain a capped or valved cleanout connection, and an accumulation tank or fitting connected so that it always contains enough condensate to fill the diaphragm chamber. The accumulator is arranged so that condensate is not siphoned from the pilot line when the low pressure steam main is under vacuum pressure when the system is shut off. A steam gauge is provided in the low pressure main not less than 10 feet from the valve, at which point pressure is generally stabilized. The low pressure side of the PRV installation also includes a pop-safety or pressure relief valve.



**PLAN VIEW-SINGLE STAGE STEAM PRESSURE REDUCING STATION**

NO SCALE

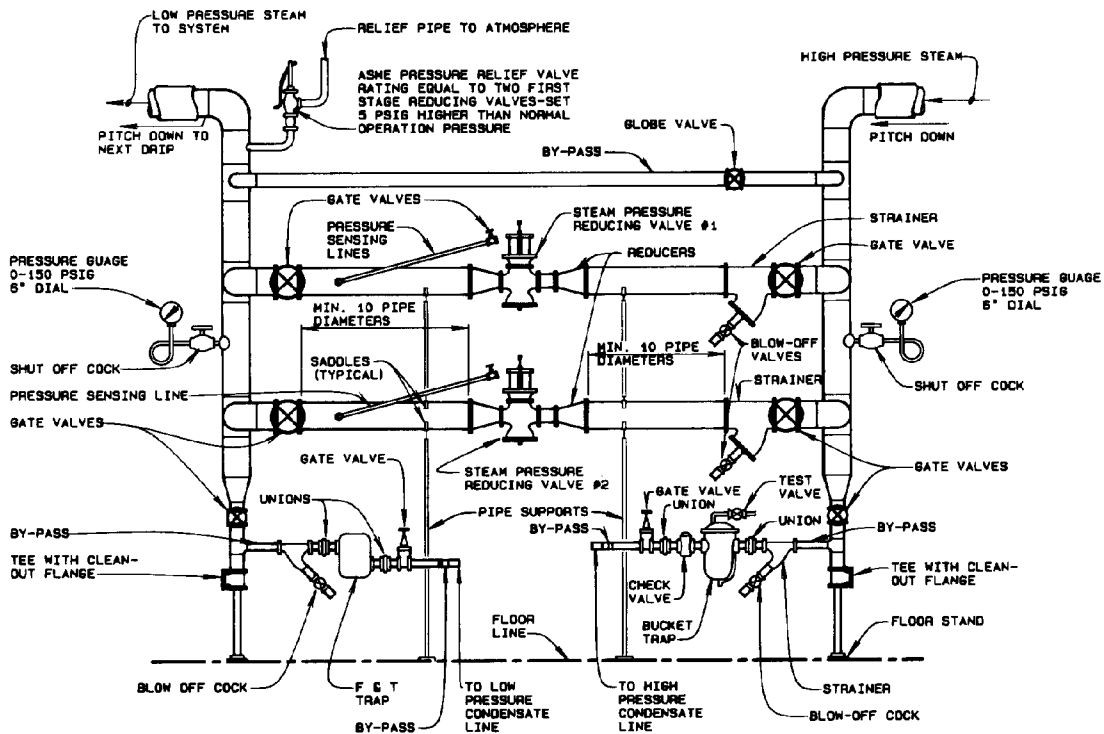

**FRONT ELEVATION-SINGLE STAGE STEAM PRESSURE REDUCING STATION**

NO SCALE

Figure 4-31. Steam pressure reducing station.

**4-69. Operation and maintenance.**

Fill the pilot line with water to avoid steam damage to the diaphragm, set the lever weights or spring load at the desired low pressure, and, if the piping system is new, clean the strainer preceding the valve several times. Maintenance will be at a minimum if clean dry steam is supplied. Periodically check the valve and seats for wear and cutting and

also check the diaphragm. Unless a shop is well equipped to grind in new seats and valves, the valves should be overhauled by the manufacturer or by a specialized valve repair shop if replacement of valves or seats is required. When wear is excessive, carefully check the condition of steam supplied for quality and contamination by foreign matter.



**4-70. Typical operating difficulties.**

Failure of the pressure reducing valve to control pressure is caused by improper sizing, plugging of the pilot line between the valve diaphragm and low pressure steam main, diaphragm failure, cut seats and valve heads, binding of the valve stem, or

incorrect adjustment of the weighted lever or spring control tension. Examine the valve stem and replace, if necessary. Change or regrind the valve and seat as required. Cut seats and valve heads indicate an oversized valve.

**Section XVI. GENERAL PROCEDURES FOR OPERATION AND MAINTENANCE**

**4-71. General.**

Although vacuum, gravity, and vapor system installations are alike in operating principle, it is seldom that two installations will be alike in installation details, such as location of valves, dampers, header and piping connections. It is therefore, important to examine and check an installation before taking over operation of a new system. New operators should check the pertinent details of an existing installation when taking over the responsibility of its operation. Well defined procedures for operation of high pressure boilers, because of the hazards involved, are stressed by insurance and safety organizations. Property damage and injury to personnel can also occur when low pressure heating equipment fails. Proper functioning of mechanical equipment is possible only when equipment has been properly installed and placed in service. The operating and maintenance organization should have a knowledge of proper installation and initial start-up procedure. Detailed installation instructions, dimension prints, operating instructions and maintenance procedures are made available by most manufacturers and should be used and made a part of the equipment or operating file.

**4-72. Valves and piping.**

Inspect all system piping carefully; determine that it is free of leaks, properly pitched in the direction of flow, and free of stoppages due to oil, grease, and other foreign matter, and that drip and vent connections and accessories such as drip traps and air vents are in proper operating condition. Note the location and function of all valves, particularly those in the boiler room, and check them for proper operation. The condition of valves is important and should be determined before needed for use in emergency conditions. The opening of bypass valves through the system, by building occupants or others unfamiliar with their purpose, results in considerable operating difficulty. This should be considered when difficulties are due to excessively hot return lines. Bypasses around traps, reducing valves, control valves, and pumps should be tightly closed except during emergency repair periods. It is of extreme importance that the layout of the

boiler feed system and its pump connections, water line regulators, automatic feeders, and make up water connections be clearly understood. When a boiler is in operation, pull the popsafety valve to determine that it is free to open. Test this valve periodically under boiler pressure to determine that it is properly set. Check hangers, anchors, expansion bends or joints to determine that piping weight is properly distributed and that hangers and rollers are free to permit movement of piping from expansion and contraction.

**4-73. Water level.**

The most important item to note in boiler operation is maintenance of a proper water level in the boiler. Too low a water level may result in permanent damage to the boiler. Too high a water level will cause delivery of wet steam and carry over of slugs of water which will result in system failure and the possibility of piping breakdown as a result of water hammer. Determine the proper water level for the particular installation and be certain that it is maintained at all times. Do not depend on automatic devices as an assurance that water level is being maintained. Observe water level in the gauge glass frequently during each operating shift, particularly when taking over a shift. If the water level fluctuates, determine the cause immediately and take corrective action.

**4-74. Combustion equipment and controls.**

Operating efficiency can be obtained only when firing systems and controls are functioning properly. If the system is hand fired, (coal) determine that grates are free to operate and clear of clinkers, and that the ash pit does not contain excessive accumulations of ash or other foreign material. Control of hand fired units usually consists of a pressure actuated damper regulator, with connections to the boiler draft damper and a check damper located at the smoke outlet. Be sure that damper chain connections are in place and that pulleys or other guides permit free movement of chain connections, and that the regulator is properly set and in operating condition. If the boiler is automatically fired, determine that fuel storage is

being adequately filled and that fuel and air adjustments are correct. Determine also that electrical connections, line switches and fuses are of the correct rating. Check controls periodically, particularly for the cut-in and cutout point of the pressure limit switch, and the cutout point of the low water cutoff switch.

#### 4-75. Boiler structure.

Inspect the general condition of the boiler setting and covering, to be sure that setting is free of air leaks, and in good structural condition. Inspect exposed surfaces, particularly the crownsheet and interior surfaces of the combustion chamber, and the lower areas at the mud ring for water leaks and corrosion. The surfaces on the fire side should be

inspected often to determine that firing procedures are correct and are not causing excessive sooting and that surfaces are cleaned as required. Open the bottom drain valves periodically to flush out scale, grit, and other foreign matter which, if allowed to accumulate, results in boiler burn out and other serious damage.

#### 4-76. Housekeeping.

Keep the boiler room clean and tools properly placed. A disorderly, cluttered boiler room constitutes a definite hazard to personnel safety and is a detriment to proper maintenance and operating efficiency. The floor should be clean at all times and kept clear of water and loose tools and materials. Accumulated material is a serious fire hazard.

### Section XVII. TYPICAL STEAM HEATING OPERATING DIFFICULTIES

#### 4-77. Water level fluctuation.

*a. Rapid fluctuation.* Rapid cycles of water level rise and fall or a bouncing water level, is usually caused by grease and oil in the boiler. The grease and oil form a film on the surface of the water and cause rolling of water which is released in slugs with the steam. Excessive firing rates cause high steam release rate with entrained moisture or excessive steam velocity through boiler outlets which may siphon water from the surface and produce a bouncing water level. Gauge glass connections placed at very active circulating points of the boiler result in siphonic or forced flow action in the water column; this gives the appearance of fluctuating water level, though the actual boiler water level is satisfactory. The water level may be too high, causing siphon action or carry-over of boiler water.

*b. Slow fluctuation.* Slow rise and fall of the water level in single boiler installations is usually due to a vacuum or condensate pump returning condensate in excessive quantity at each feeding cycle. This occurs when the distance between receiver water levels at pump cut-in and cut-out is too great. This condition can also be caused by water which is forced out through return connections of gravity systems owing to failure to equalize as the result of long runs of mains or by an excessive initial steaming rate. In multiple boiler installations, water may be higher in one boiler because of an uneven firing rate.

#### 4-78. Low water level.

Low water level is the most serious situation that may occur in a boiler plant. Automatic water feeders should not be depended upon for assurance of proper water level, as accidents to piping may

result in instantaneous make-up water demand beyond the capacity of the feeder. When low water level is detected, shut off automatic firing equipment immediately or open firing doors and shut off draft of hand fired boilers to cool the boiler gradually. *Do not open cold water make up lines.* After the boiler has cooled, proceed to determine the cause of water loss. Low water level indication may be due to any of the following causes:

- a.* Water-gauge glass either shut off manually or water drained from the glass.
- b.* Broken boiler sections or excessive leak in steel boiler.
- c.* Pump failure or broken return main from system to pump or valve at pump inlet shut-off.
- d.* Broken or stopped up pump discharge line to boiler or return valve at boiler shut-off.
- e.* Excessive oil, grease, and foreign matter in boiler water resulting in excessive priming.

#### 4-79. Loss of pressure.

*a.* If pressure fails, check for the following possible causes:

- (1) Inadequate firing rate or poor combustion condition, insufficient draft, soot clogged boiler passages and breeching, or inadequate air supply to the boiler room.
- (2) Dirty boiler including either scale on water side, soot on fire side, or both.
- (3) Broken main causing excessive loss of steam.
- (4) Steam load in excess of boiler capacity.
- (5) Oil or grease in boiler water.
- (6) Steam gauge may be defective, not properly indicating actual pressure conditions. Open test

cocks and note if steam pressure is available regardless of gauge indication.

*b.* Do not confuse pressure failure with a condition under which closed vapor or vacuum systems may be circulated under negative pressure or vacuum because of temperature or other controls which cause a low firing rate, balanced with low space heat demand. Induced vacuums will occur when the radiator condensing rate exceeds the boiler evaporation rate.

#### **4-80. Pounding in the system.**

This should not be confused with snapping which occurs when expansion takes place at initial heating up of systems. Pounding or water hammer is caused by slugs of water which are carried at high velocity with steam and which may have sufficient force to break piping, in addition to creating excessive noise. Existence of water slugs in steam piping is the result of:

*a.* Carry-over through the boiler nozzle due to excessive steaming rates, priming due to grease and oil in water, or the water level being too high.

*b.* Condensate trapped in piping system because of sagging mains and pockets; plugged and faulty steam main drip connections.

*c.* Air bound mains due to defective vents which trap condensate behind the air pocket.

#### **4-81. Heating unit malfunction.**

This is basically a failure of the steam space of the radiator, coil, or steam chest to fill with steam and is due to:

*a.* Inadequate steam pressure.

*b.* Defective valve (in which the disc may have fallen onto the valve seat), valve plugged with scale, or failure to open.

*c.* Air bound radiator caused by defective air vent or trap.

*d.* Water logged radiator caused by defective trap.

*e.* Discharge connection pocketed or rising from unit causing flooding of unit.

*f.* Traps of inadequate capacity.

*g.* Heating coils of excessive length and height may fail because of air binding and should be provided with vent connections and/or vacuum breakers in accordance with the manufacturer's recommendations.

*h.* Inadequate pitch of the heating element or radiator will cause faulty 'drainage and failure to heat. This is particularly marked in small horizontal extended surface, fin-tube radiation.

#### **4-82. Failure of space to heat.**

If space heating units such as unit heaters or blast systems are filled with steam, the ductwork and fans should be checked for air delivery and distribution. Lack of heat may be caused by fan motors which are running under speed or by reduction of duct capacity due to closed or partially closed dampers. Heating failure and lack of proper distribution often occurs in large spaces such as aircraft hangers and work shops, caused by the inability of unit heaters located too high above the floor, to force air to the work space. Stratification of heated air at ceilings in such installations may be overcome by use of recirculation ducts which have floor inlets and which connect to the inlet side of the unit heaters. Also, check the heat loss of the space; be sure to include the load imposed by an exhaust air system and compare the load with the capacity of installed heating units.

#### **4-83. Pump venting steam.**

Do not confuse this with low temperature vapor or moist air discharged from pump vent. Steam venting from condensate or vacuum pumps is caused by leaking traps, open bypasses around traps, or backup of high temperature boiler water into the pump due to leaking check valves in the pump discharge line. High temperature water is present in the pump when steam is observed to be venting from the pump. This may result in vapor binding of the pump. If the pump is a vacuum type it will fail to create a vacuum at excessive condensate temperatures. When steam discharges from vents of vacuum pumps or high condensate temperatures exist, the pump should be placed on float control. If allowed to remain on vacuum control, the pump will run continuously and will accomplish no useful purpose. If check valves in the pump discharge line leak, the pumping units will cut in frequently and cut out for relatively short periods, depending on the rate of boiler water backflow into the pumps.

#### **4-84. Pump venting water.**

If water is venting from the pump check, consider the following possible causes:

*a.* Pump capacity, volume or discharge pressure of pump, is inadequate. Determine the discharge pressure at the pump outlet by installing a pressure gauge at this point and checking with manufacturer's performance and capacity charts or curves. Open the return connection to the pump and measure the rate of condensate flow to determine the quantity to be pumped.

*b.* Pump may be rotating in wrong direction. This can be readily determined by touching a rubber

tipped pencil to the shaft. Note the direction of rotation and compare with manufacturer's drawing or, if present, the direction arrow mark placed on pump casing.

*c.* Pump control may be failing to cut in pump at proper receiver level.

*d.* Pump impeller may be worn or clearances may be too great, reducing discharge capacity of the pump.

*e.* Outlet valve of pump or discharge line may be clogged.

*f.* If the pump is controlled by a float controller at the boiler line and equipped with a float controlled makeup water valve at pump receiver, the makeup valve may be leaking or set too high. Under these conditions the pump may cut in and satisfy the boiler water level with makeup water, followed by condensate returning to the pump in large volume with no demand for boiler water level replacement, which results in overflow of the receiver. This can be corrected by adding an auxiliary receiver above the pump receiver to take care of overflow, or by changing the control system to a standard pump receiver level control in place of the boiler water level control.

#### **4-85. Steel boiler failure.**

If a steel boiler burns out or leaks, check for the following possible causes:

*a.* Low water level, particularly if the failure is in the area of the crown sheet.

*b.* Failure in lower area of combustion chamber. This is usually caused by accumulation of mud, scale and other foreign matter in the mud ring area which results from improper cleaning and blowdown.

*c.* Corrosion on the fire side of the boiler caused by improper layup or cleaning.

*d.* Interior corrosion caused by improper layup or water conditions.

*e.* Leaks at tube ends, drain openings, and man-holes will, if not corrected immediately, result in corrosion of adjoining plates.

*f.* Improper suspension or expansion provisions of headers and piping if leaks or fracture occur in the area of boiler connections.

#### **4-86. Cast iron boiler failure.**

If a cast iron boiler cracks, check for the following causes:

*a.* Check water line conditions.

*b.* Excessive firing rates may cause "dry spots" in the water side of the boiler, particularly if water contains oil, grease, and other foreign matter. Check for faulty circulation in narrowed drop sections or baffles at the rear of the combustion space.

*c.* Header connection may not be properly arranged to permit expansion and contraction of header and system connections. This usually results in fractures in the area of the header connections.

*d.* Staybolts too tight to permit expansion and contraction of sections.

*e.* Accumulation of soot and scale which work into the space between sections and result in growth and expansion, which may break sections.

*f.* Excessive feed of cold water to a hot water boiler may cause failure.

#### **4-87. Boiler room smoke.**

Presence of smoke and combustion gases in the boiler room is a serious condition. Combustion gases such as carbon monoxide may be created wherever there is incomplete combustion of gas fuel, generally, because of inadequate draft in a gas appliance or a leak in the furnace's heat exchanger. When such conditions exist, corrective measures should be taken immediately. Check for the following possible causes:

*a.* Check for a closed boiler outlet damper or stoppage of the breeching or stack.

*b.* Check to see that the tube or gas passages of the boiler are not closed by an accumulation of excessive soot and fly ash.

*c.* Determine that sufficient door, window, or other openings are in use to permit air necessary for combustion to enter boiler room.

*d.* Leaky settings or breechings will permit gas leakage to the boiler room during periods of positive pressure in the combustion chamber. Check the boiler settings for leaks by using a candle to note suction at surface cracks and joints when the boiler is under negative pressure.

*e.* Stack or breeching may be inadequate.

*f.* Breeching may have too many sharp turns, or may pitch downward and reduce the effective area.

## Section XVIII. SUMMER LAY-UP PROCEDURES

### 4-88. General.

Most damage to and deterioration of heating equipment occurs during summer and other lay-up periods because of careless or inadequate procedures in placing equipment on inactive basis. During these periods excessive rusting, corrosion, and grease clogging occurs. If the idle period includes periods of freezing temperature, incomplete drainage will result in damage from freezing. Well planned procedures must be followed in placing heating systems in proper condition for standby.

### 4-89. Draining system.

Drain all steam and return lines of condensate completely by opening drain valves at pumps or return connections in the boiler room, and by opening the drain or dirt pockets located at ends of mains and at other drip points in the building piping system. Particular care must be taken to assure proper draining of wet returns and loops under doorways. During draining operations, it is important to determine that piping is properly pitched and that no low points or pockets which can accumulate water are present. This is particularly important in servicing wet return lines. Mains under basement floors should be opened at both ends and blown out with compressed air. Leave drain points open during lay-up to permit air movement and reduction of sweating. Threads of drain plugs, caps and other similar pieces of equipment should be carefully brushed clean of rust and other debris, thoroughly coated with oil and tied to the drain point to be readily available for reinstallation at the start of the heating season. Drain openings should be covered with a single layer of cloth to prevent entrance of rodents and foreign matter. If drainage through available drain points is inadequate, disconnect intermediate unions to assure drainage of piping. Also note condition and exposure of outdoor mains to assure that they will not be damaged by outside weather conditions or by accumulated water in pits, conduits, and tunnels.

### 4-90. Boiler cleaning and lay-up.

At the end of the heating season, boilers should be opened, thoroughly washed internally, and laid up so that the water side and fire side are free of corrosive material. All personnel engaged in boiler cleaning and spraying should be provided with proper respiratory and eye protection, and suitable protective clothing. The following methods are recommended for lay-up of boilers.

#### *a. Cast iron boilers.*

(1) Clean boiler thoroughly and remove grates, if applicable, to facilitate access and inspection. Use wire brushes to remove all soot, dirt, and scale from flues and firebox surfaces. Open boiler drain plugs at the front and rear of boiler. If drain is not present, open the return header and thoroughly wash out the boiler using a hose with water at sufficient pressure to loosen mud and accumulated sludge. Complete removal of accumulated foreign material in the lower sections of the boiler or mud ring is of extreme importance.

(2) Spray flue surface with light lubricating oil, using an oil gun with an extended stem and bend end, so as to reach all corners and crevices. Used crankcase oil is unsatisfactory for this purpose.

(3) Remove all ashes and unburned fuel from the grates and ashpit of hand fired coal burning boilers.

(4) Clean the smokepipe and remove it during the summer, if feasible. If controls are mounted in the smokepipe be careful not to disturb them.

(5) Leave boiler doors and dampers open during the lay-up period. This will permit air movement through the setting and will help prevent sweating on the inside of the boiler while not in use.

(6) Oil hinges of all doors and moving parts of regulators.

(7) On hand fired boilers replace warped, broken, or worn out grates which, if not serviced, would permit unburned coal to drop into ashpit and would also affect proper combustion during the heating season.

(8) Tie rod nuts should be removed and replaced with spring washers and safety nuts to permit safe expansion conditions.

(9) Cast iron steam boilers, following cleanup of the boiler at the end of heating season, should be completely filled until the start of next heating season.

(10) If an automatically fired steam boiler is operated during summer months for operation of submerged type domestic water supply heaters, maintain the water line above normal for steaming. Improved circulation to the heater will result.

(11) Brush exterior exposed iron work with a wire brush, and, after removing all rust, paint with rust proof heat resisting paint.

#### *b. Steel boilers (dry method)*

(1) Do all lay-up work for steel boilers immediately after the close of the heating season.

(2) Draw the fires, remove all combustibles, and drain the boiler while still warm. This prevents drying of loose mud, rust, and some types of scale.

(3) Open valves to all radiators and all other heating elements wide to permit condensate to drain back to the boiler, boiler feed pump, or opened piping drain points.

(4) Remove all manhole plates and washout plugs from the boiler and set to one side.

(5) Wash the water side boiler surfaces clean and remove all loose scale and sediment by flushing thoroughly with water pressure from a hose.

(6) Use all washout openings, starting at the lowest point in the boiler and working toward the top. Then repeat the washing by flushing from top down to lower openings.

(7) Open the city water or makeup water valve to flush the bottom of the boiler. When the boiler has been flushed, make certain this valve is closed tightly and does not leak.

(8) Flush out all boiler accessories such as water column piping, water column, gauge glass, pressure damper regulator, and steam gauge thoroughly. All automatic controls on mechanically fired boilers should also be cleaned thoroughly.

(9) It is important to clean the fire surfaces of the boiler. Fire tubes or flues should be punched or scraped thoroughly using a scraper which cuts down to the tube wall. Combustion surfaces should be brushed thoroughly with a wire brush to remove all soot, carbon, and scale. For coal fired boilers, remove the entire grate assembly from the boiler and set aside for inspection and repair.

(10) Scrape carbon and other foreign matter from the corners of the firebox as well as the inside of the firebox sheets, crown sheets, and front and rear tube sheets, using a wire brush and scraper.

(11) Clean soot and carbon from the outside firebox sheets, outer shell and throat sheet on all bricked-in-boilers. Clean inner brick walls and boiler shell including combustion chamber, smoke breeching and base of stack, of all soot.

(12) Remove all soot from the boiler room.

(13) Inspect the boiler thoroughly for any weakened or corroded places and have repairs made as early as possible.

(14) Coat all fire surfaces as far as possible with a mineral oil, giving special attention to fire tubes, corners of the firebox, and blow-off connection.

(15) Allow steel boilers to remain dry and empty all summer, permitting free circulation of air

through all parts of boiler by keeping all doors and wash-out openings open.

(16) If the boiler room is damp or air circulation is poor, moisture may be absorbed by placing pans of unslaked lime in the boiler. Replace lime when necessary.

(17) For coal fired boilers, clean the grate assembly and inspect thoroughly. Replace any parts that are burned or even slightly warped.

(18) Make every effort to clean the boiler properly. A thorough cleaning is good assurance of freedom from boiler trouble throughout the next heating season.

*c. Steel boilers (wet method).* If a boiler is on standby service, the following wet method of boiler lay-up is recommended:

(1) Drain the boiler completely. Check to be certain that water walls and gauge columns are not overlooked. Next, open the boiler and wash clean and free from all loose scale and sediment by flushing thoroughly with strong water pressure. Use a stiff brush to clean all internal surfaces of the boiler that can be reached. Break the feed-water and steam connections to the boiler and blank the connections if other boilers are operating.

(2) Fill the boiler with either feedwater, return condensate or raw water, whichever is available. While the boiler is being filled, add the following:

(a) Caustic soda. (Caustic is added in sufficient quantity to maintain a PH of 9.5 to 11.)

(b) Sodium sulfite. (Approximately 0.03-0.06 pounds per 1,000 gallons of boiler holding capacity or 30-60 PPM.)

(3) Start a light fire in the furnace. Open the vent or safety valve and boil the water within the boiler under atmospheric pressure for two hours to ensure circulation of chemicals. When the water has cooled, fill the boiler to the top, overflowing safety valves to make sure complete filling is accomplished.

(4) Make periodic inspections to ensure maintenance of water level. Replace all water loss from the boiler. It may be necessary to add additional chemicals to the boiler to maintain the original concentrations of caustic soda and sodium sulfite.

#### **4-91. Stokers.**

At the end of the heating season, remove all coal, clinkers, and ash from stoker retort and grate area. Wire brush the hopper thoroughly and give it a coat of rust resisting paint. Drain the gear case of hydraulic drive oil, flush with clean flushing oil, and refill with oil of the viscosity recommended by the

manufacturer. Clean the motor, electrical controls, refill oil and grease cups, open line switch, and close and seal switch box. Clean the retort carefully, remove ash and foreign material from air openings, and replace defective or burned out tuyere blocks as necessary. Patch or replace refractory of stoker heart and bridge wall if present. Run oil soaked sawdust or shavings through the screw to remove foreign material and leave screw and retort filled with clean, oiled shavings to prevent rusting during the lay-up period.

#### 4-92. Oil burners.

Complete clean-up and check of oil burning equipment at the end of each heating season is necessary to assure proper operation during the following heating season.

- a. Drain and clean strainer.
- b. Oil all bearings with a good grade of medium motor oil at the end of the heating season and periodically during the heating season.
- c. Clean the blower wheel, blower wheel housing, and air passages.
- d. Inspect and clean automatic ignition devices.
- e. Clean and inspect the combustion chamber for cracks and leaks.
- f. Inspect and clean the nozzle. Sharp metal tools must not be used for cleaning nozzles. Inspect and clean the cup of rotary cup burners and the pot of pot type burners.
- g. Clean sleeves, oil grooves, and the oil inlet pipe of range burners and replace the kindling wick if necessary.
- h. Check automatic control and safety equipment for operation, contact points, and setting.
- i. Inspect and clean the fuel oil tank if necessary. A full oil tank eliminates air and thereby prevents tank corrosion resulting from moisture condensation. Screen vents to prevent entrance of dust and dirt. Check the oil line for leaks.

#### 4-93. Gas burners.

At the close of the heating season, procedures for lay-up of gas burners are relatively minor in scope. These consist briefly of cleaning the combustion chamber (including repair of refractory) and covering burner to prevent rust and entrance of foreign material. Check gas piping and valves in the boiler room carefully for leaks and check the control system and ignition system for proper operation.

#### 4-94. Pumps.

Service switches to all pumps should be locked in the open position before starting repairs. At the close of the heating season, open the receiver and

pump housing drains, remove all rust, sediment and other accumulations, flush thoroughly with clear water, remove inlet strainers, and clean screens. Open pump housing, wipe interior out, check moving parts for wear, make any necessary replacements, and remove the float from the receiver and check it for leaks. Motor driven vacuum pumps are equipped with various types of auxiliary valves with hardened metal, bronze, or composition surfaces, and are installed so that they are readily accessible. Check the manufacturer's drawing or service manual to ascertain proper methods of access to these valves. Inspect valves carefully and repair or replace seats and discs as necessary. It is of extreme importance that the valves of motor driven vacuum pumps be in proper operating condition to assure correct cycling of the unit. Clean the motor and electrical controls, open the line switch, remove fuses and place in the fuse box, and close and seal fuse and switch box. Leave the drain valve at the inlet to the pump open, and close pump inlet valve to prevent any trapped system water from returning to the pump during the lay-up period. Leave drain openings and plugs on the pump open, clean cap or plug threads carefully, and coat with oil to prevent rust. Coat the pump shaft with oil or grease to prevent rust. Clean the pump exterior and base thoroughly and give it a coat of rust resisting paint. Be sure to place new gaskets which may be required to reassemble the pump for service at the start of the heating system in a waterproof wrapper tied to the pump. Mark the wrapper, so that its contents can be identified easily. Be certain all guards on equipment are in place before starting the unit.

#### 4-95. Valves and strainers.

Inspect and service the main shutoff and distribution system valves completely. Open the bonnets for repair of discs and seats, replace the packing and place a coat of light oil on the valve stem. Do not paint the valve stem or bonnet threads and bolts. Open check valves and clean and repair discs and seats as required. Open and clean strainers ahead of traps, control valves, and other similar pieces of equipment.

#### 4-96. Traps.

a. *Float-type traps.* Open and clean out float-type traps at the ends of mains and at intermediate drip points carefully. Clean the valve head and seat with a soft clean cloth. Do not use files, chisels, or coarse abrasives to clean valves and seats. Check the condition of thermostatic diaphragms of traps which are equipped to vent air. Most traps have

bottom drain plugs. Leave these plugs open during lay-up season, clean the threads carefully and coat with oil to permit easy assembly at the start of the heating season.

*b. Thermostatic traps.* Open and clean out thermostatic traps on radiators and other equipment with soft clean cloths. In replacing the threaded covers, clean threads and coat surface with a light even coat of oil or dried film lubricant conforming to military specification MIL-L-46147. The use of graphite on threads is not recommended as this material becomes corrosive when wet. Use new cover gaskets. Check diaphragms for correct operation before closing the trap.

#### 4-97. Controls and electrical connections.

Check the wiring and conduit in the boiler control boxes which often are loosened during operating periods through carelessness with firing tools. Clean the interiors of control units of dust and soot accumulations, inspect and clean contact points, and close the boxes tightly. Equipment should be returned periodically to the manufacturers for factory overhaul and service as local conditions warrant.

#### 4-98. Stack and breeching.

*a. General.* The stack and breeching will contain soot and other accumulations not readily removed during the operating period. Combustion products usually contain sulfur, which condenses and adheres to relatively cold surfaces of the stack and breeching. Sulfur combines with moisture in the air to form sulfuric acid which is very corrosive to metal breechings and stacks. It is therefore necessary to clean interior surfaces of steel breechings and stacks with a wire brush to remove soot deposits, and when surfaces are accessible, to apply a coating of heat and rust resistant paint. Proper respiratory and eye protection equipment must be

worn by personnel engaged in cleaning stacks and breechings. Take the breeching down to permit access to the interior for proper cleaning procedures. Allow check dampers and access doors of breechings to remain open during lay-up periods to permit free air circulation.

*b. Cleaning.* The procedure to be followed for cleaning the stack depends on its size and accessibility. Relatively short stacks may be cleaned by use of a long boom with a pulley and a line at the top to permit inserting and moving a weighted brush or gunny sack filled with rags or excelsior up and down the stack. Accumulated soot may be burned out by kindling a paper and wood fire in the stack base. However, adequate provision for patrolling adjoining roofs and prevention of fire damage to buildings must be provided during the operation.

*c. Lay-up.* Provide steel stacks with a loose cap to prevent rain water from entering at the top during the lay-up period. Allow the bottom clean-out door and the breeching access doors to remain open during the lay-up period to permit air circulation. It will be found that with ample air circulation, soot and adhering scales will have a tendency to break loose. Soot and scale should be removed periodically to avoid corrosive action at the stack base or in the breeching. Brush exterior surfaces of steel stacks clear of rust and apply a coating of rust resisting paint when necessary. Clean and paint rust spots carefully since rust-through and permanent damage will occur quickly after the surface is exposed and the initial rust is visible, unless given immediate attention. Rust and corrosion of steel stacks and breechings occur from both the inside surface and from the outside surface. Rust and corrosion prevention on inside surfaces may be difficult because of limited accessibility. However, exterior surfaces can be readily protected and the stack life prolonged by prevention of rust and corrosion from the outside.

### Section XIX. ENERGY CONSERVATION

#### 4-99. Isolate off-line boilers.

Light heating loads on a multiple boiler installation are often met by one boiler on-line with the remaining boilers idling on standby. Idling boilers consume energy to meet standby losses, which can be further aggravated by a continuous induced flow of air through the boiler into the stack and up the chimney. Unless a boiler is scheduled for imminent use to meet an expected increase in load, it should

be secured and isolated from the heating system (by closing valves) and from the stack and chimney (by closing dampers). A large boiler can be fitted with a bypass valve and regulating orifice (figure 4-32) to keep it warm, thereby avoiding thermal stress when it is brought on-line again. If a boiler waterside is isolated, it is important that air flow through the stack is prevented; it is possible for back flow of cold air to freeze the boiler.



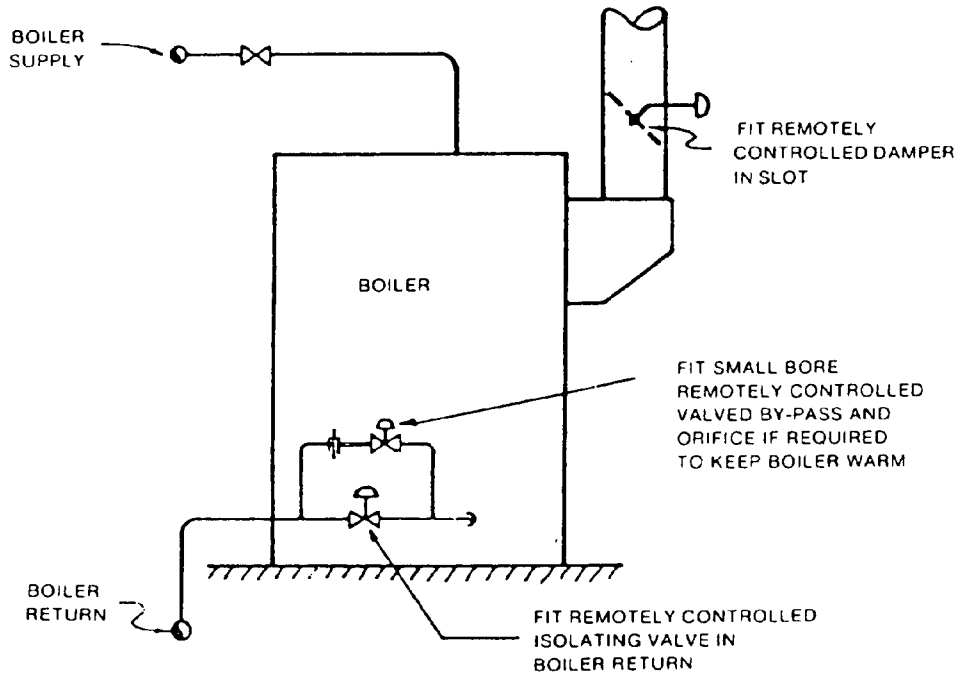

Figure 4-32. Warm-up bypasses for a secured boiler.

**4-100. Maintenance of pipe and boiler insulation.**

Existing pipe insulation that is in a bad state of repair, should be stripped off and replaced. If the worn sections are restricted to a few locations, the insulation should be replaced in those areas only. If there is any doubt about whether or not the insulation is asbestos, a sample should be taken and analyzed. If it proves to contain asbestos the removal should be handled in accordance with established policy. Where hot pipes are insulated but the insulation is of minimal thickness and effectiveness, additional insulation should be applied over the existing insulation. Do not insulate steam traps or the first six feet of the condensate discharge piping from the trap, except where personnel could come in contact with hot surfaces. Check with the local fire authorities to determine whether the selected insulation is acceptable or is considered a fire or smoke hazard. In buildings where food is either stored, processed, or sold, avoid the use of fibrous insulating materials if there is any possibility of fiber migration. Consult the Food and Drug Administration for prohibited materials.

**4-101. Steam trap leak detection.**

Failure to detect signs of early steam trap wear and dirt build-up, because of the lack of a regular trap inspection program can result in large energy losses and heat exchange equipment failure. No single

inspection technique can be used to check all traps, but a combination of the following general procedures should be incorporated into any steam trap inspection program.

a. *Visual testing* A test which allows visual inspection of a steam trap's operation is considered to be the best approach. The method must be used with the knowledge that it is not infallible and that its reliability varies among the various types of traps. This procedure requires an isolation valve in the condensate line downstream of the trap and a test valve in a tee stubbing off the condensate return line just between the trap and the downstream isolation valve. The purpose of this "block and Bleed" valve arrangement is to isolate the trap discharge from the condensate return system and allow its inspection through the test valve. A typical arrangement is illustrated in figure 4-33. The inspection of trap operation requires that the isolation valve in the condensate return line be closed and the test valve be opened. Observation of the discharge from the test valve offers excellent insight into the operation of the trap. The possibilities are discussed below:

- (1) Nothing is discharged from the test valve.
  - (a) Trap may have failed in the closed position.
  - (b) There may be a vacuum in the system heat exchange unit preventing draining.
  - (c) There may be a leaking bypass valve upstream of the trap.

(d) Debris may be clogging the trap or line and only cleaning of the strainer and trap may be required.

(e) System pressure may be too high for the trap due to trap wear, incorrect sizing, malfunctioning pressure reducing station, or vacuum in the return line.

(f) The air vent may not be functioning correctly.

(g) The trap may be installed backwards (if it is a thermodynamic disc trap).

(2) A continuous discharge is emitted from the test valve.

(a) This may indicate that no problem exists. For example, float and thermostatic (F&T) traps and orifice plates may continuously discharge condensate which can flash into steam when

released to the atmosphere. It is very important to have a trained and skilled observer who can distinguish between superheated steam leaking through a failed trap and flash steam (saturated steam formed when condensate is released to the atmosphere).

(b) This may indicate, on some trap types, that the trap has failed in the open position.

(c) The trap may be too small for the application.

(3) The discharge from the test valve is intermittent, with no appreciable water or steam visible between discharges.

(a) Trap may be functioning properly.

(b) May be an indication of failure in orifice plates or F&T traps which are designed for continuous discharge.

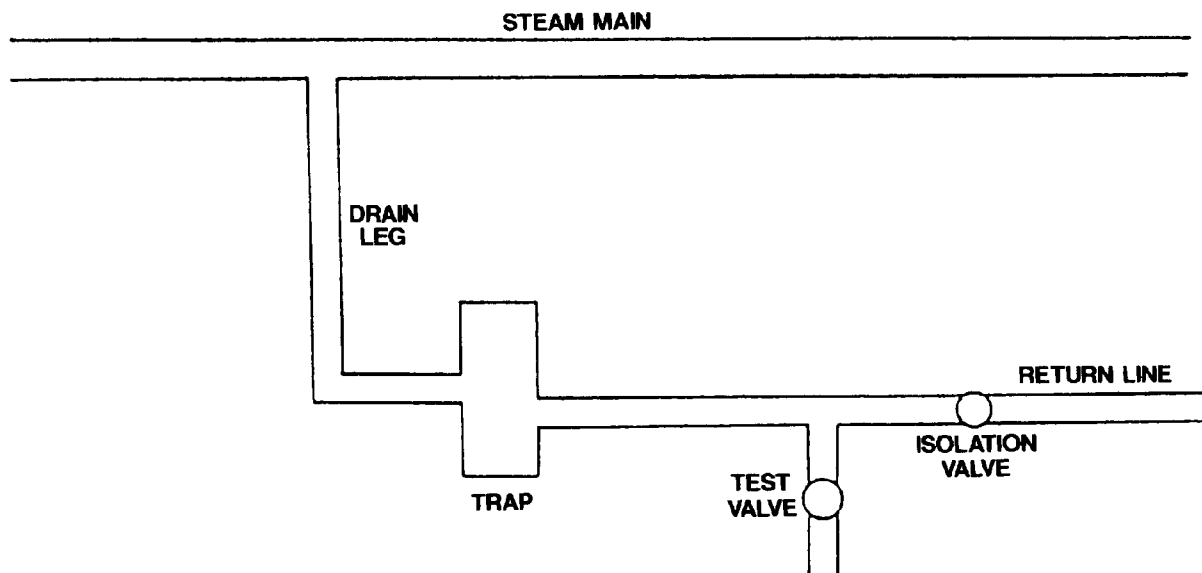

Figure 4-33. Steam trap test valve set-up.

*b. Audible testing.* Holding one end of a steel rod or stethoscope firmly against the trap cap and listening at the other end is a popular method of testing traps. The use of this technique requires considerable experience in order to differentiate between indicative trap noises and other noises that may be transmitted through adjacent piping. The following descriptions of various trap sounds have been given credence by trap manufacturers and practitioners of the conventional audible inspection:

(1) *Bucket traps.* A properly operating bucket trap will make a cycling sound as it opens and closes. A failed bucket trap (they always seem to

fail open) has been described as making a whistling sound or a “whooshing” sound.

(2) *Thermostatic traps.* A properly operating thermostatic trap will make no sound, the sound of periodic discharge may be heard, or continuous but fluctuating sounds may be heard. A thermostatic trap failed closed will make no sound; a thermostatic trap failed open will make a whistling sound.

(3) *Thermodynamic traps.* A properly operating thermodynamic trap will make a clicking or snapping sound as it opens and closes several times

per minute. A failed trap will make a rapid chattering sound.

*c. Ultrasonic testing.* A more modern, yet more costly, approach to steam trap testing involves the application of ultrasound. An ultrasonic leak detector is a listening device that detects sound in the high frequency range. With this equipment, the operator can hear the movement of steam within the trap without interference from other sounds. Again, experience with both the equipment and the methods is required for satisfactory results. The following noise descriptions are given as a general guide.

(1) *Bucket traps.* Operation is intermittent. The tester will easily learn to distinguish between normal and malfunctioning operation. When the trap is working properly a hissing noise will be heard during discharge; when the trap closes, the noise should stop. Continuous "hissing" indicates that the trap has failed open (blowing), which may result from a loss of prime under light loads or a malfunction of the trap mechanism.

(2) *Thermostatic traps.* When properly sized, will discharge intermittently; therefore, if the trap is operating properly, a loud hissing sound will be heard during discharge; no sound will be heard when the trap is closed. If hissing continues after closing, the trap is leaking. If the condensate load exceeds the leakage, only condensate will be lost from the trap. If the condensate load is less than the leakage, however, the hissing will continue for a prolonged period and steam will be lost. The trap will cycle only when the condensate load again exceeds the leakage, and subcooling of the condensate occurs in the trap. If the trap continues to cycle regularly, it is probably functioning properly. Some thermostatic traps tend to throttle under certain load conditions. When these conditions exist, the test instrument will emit a continuous hissing. When this occurs, the trap can be tested only by reducing the load. Under low load conditions, even these traps cycle rhythmically.

(3) *Thermodynamic traps.* The trap opening and closing frequency depends upon the trap load and the mechanical condition of the trap. If the trap cycles fewer than ten (10) times per minute, it is operating normally. If the trap is worn, its cycling rate will increase significantly; if the trap discharges continuously (no cycling), the loading may exceed the capacity or the return line pressure (downstream of the trap) may be too high. Line pressures both upstream and downstream of the trap should be checked.

(4) *Impulse traps.* These traps are intermittent in operation. With the trap closed, a hissing sound

will be heard, but the trap is not necessarily wasting steam. If properly sized, it should still continue to operate intermittently while hissing. A loud roar when the trap is in the discharge position followed by a much lower noise level indicates proper operation. If, however, a loud noise is heard continuously, the trap is either overloaded or failed in the open position.

(5) *Float and thermostatic traps.* These traps have a tendency to discharge continuously (particularly at low to moderate pressures) and modulate with the loads upstream of the trap. Under these conditions, ultrasonic testing is of no value. However, when F&T traps are used at high pressure, they tend to discharge intermittently, and, if the equipment indicates a rhythmic intermittent discharge, the trap is working properly.

*d. Temperature testing* Measuring the temperature of the condensate pipe beyond the trap was once touted as a reliable means for checking steam trap operation. Another temperature check regimen was to measure the temperature difference between the pipes entering and leaving the trap. Today, condensate pipe temperature is deemed a reliable indicator of trap operation only if the trap has failed closed. In this case, the trap and adjacent downstream pipe will be very close to ambient temperature. Claims have been made to the effect that a pipe surface temperature measurement in conjunction with a steam pressure measurement at the trap will allow accurate diagnosis of steam trap condition and operation; however, obtaining a trap pressure measurement requires considerable effort and expense, thus defeating the purpose of a simple, inexpensive test method. There remain, however, some technicians who advocate the use of a temperature test method for judging the condition of a trap. For those determined to use this test method, the temperature measurements should be made with a pyrometer, an infrared photometer, or by a crayon type temperature indicator. The following observations and assumptions can be made through the use of the temperature testing method:

(1) If the condensate line is at ambient temperatures, the trap has failed in the closed position.

(2) If the condensate line is warm or hot:

(a) The trap is functioning properly.

(b) The line temperature is influenced by other traps discharging into the same condensate return line and the trap under observation is actually malfunctioning.

(c) The trap has failed in the open position.

## CHAPTER 5

## HOT WATER HEATING SYSTEMS

## Section I. GRAVITY SYSTEMS

## 5-1. General.

*a.* In gravity systems, water flow is produced by the temperature difference between hot water in the supply risers and cooler water in the return risers. The velocity and rate of flow through the system piping is low, so pipe sizes must be relatively large. Gravity systems may have either an open or a closed expansion tank.

*b.* Distribution supply mains may be located in the basement with up-feed to the radiators and risers (as shown in figure 5-1), or the supply mains may be located in the attic with overhead down-feed supply risers and return mains located in the basement. The return connections are piped into a gravity return main which pitches downward to the return opening in the boiler. Because there are supply and return pipes throughout the building, all radiators are connected in parallel. The water temperature is practically the same in all radiators, except for slight temperature drops in supply mains between the boiler and the end of the circuit. Water temperatures at ends of circuits are lower than the rest of the circuit and are dependent on length of run and heating load. The rate of heat emission is also slightly lower per foot of radiation at the ends of the circuit due to the slight drop in water temperature.

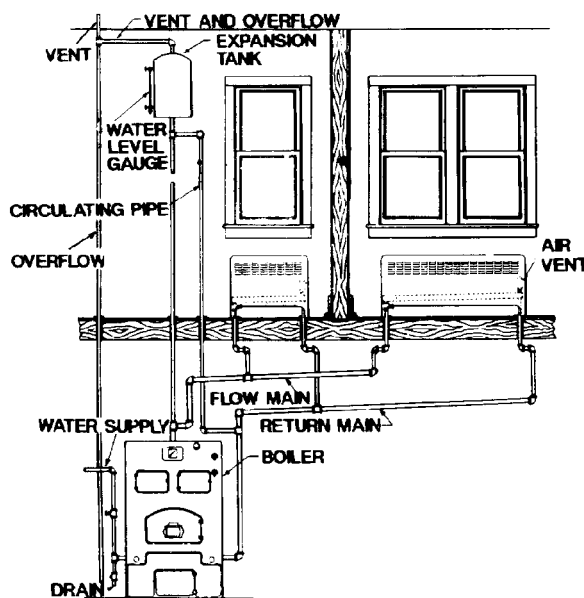

Figure 5-1. Open tank gravity system.

## 5-2. Equipment.

*a. Pressure gauge/thermometer.* For this type system, a combination pressure gauge and thermometer is used. Water temperature in the system is indicated on the thermometer scale and the system pressure on a standard gauge dial.

*b. Radiator valve.* Each radiator has a valve for closing off circulation through the radiator. To prevent freezing of water in a radiator that is closed off, a weep hole is provided to allow sufficient water to circulate at all times. Unlike ordinary steam or water pressure valves, there is no seal in these valves. There is a barrel-like section in which a disk or gate makes a half turn to close the water passage.

*c. Radiator air vent.* Each radiator has a compression air valve for venting air from the system and radiator. Radiators are tapped at the top-feed and bottom return at opposite ends. Air is also vented from radiators through supply piping up-risers to the high point in the system, from which air is vented through a connection made to the expansion tank.

*d. Expansion tanks.* All heating systems require an expansion tank to accommodate expansion and contraction of water which occurs as its temperature changes. Excess water is stored in the expansion tank until the water temperature decreases and it is returned to the system. Gravity systems are defined by the type of expansion tank installed: open tanks or closed tanks.

(1) *Open tank system.* In open tank systems, the expansion tank is freely vented to atmosphere. Normally, these systems are limited to operating temperatures of less than 180F.

(2) *Closed tank system.* In closed tank systems (figure 5-2), the expansion tank is airtight, sealed to prevent free venting to atmosphere. As heated water expands, the excess water moves into the tank and compresses the entrapped air thereby increasing the pressure on the system. When the water temperature decreases, the water contracts, air in the tank expands, the excess water returns to the system, and the pressure drops. A closed expansion tank must be large enough to keep a reservoir of compressed air above the water level to cushion the excess water that enters. Thus the tank must provide space for changes in both water and air volume. A small tank with insufficient air can

cause two undesirable conditions to occur. As the temperature increases, the water expands and the system pressure may increase above the permissible level. This can cause the relief valve to open and waste water. As the temperature drops, the water contracts and the pressure may drop below the permissible minimum. Air will not vent from the system and additional air may be drawn in if the high points of the system have automatic air vent valves.

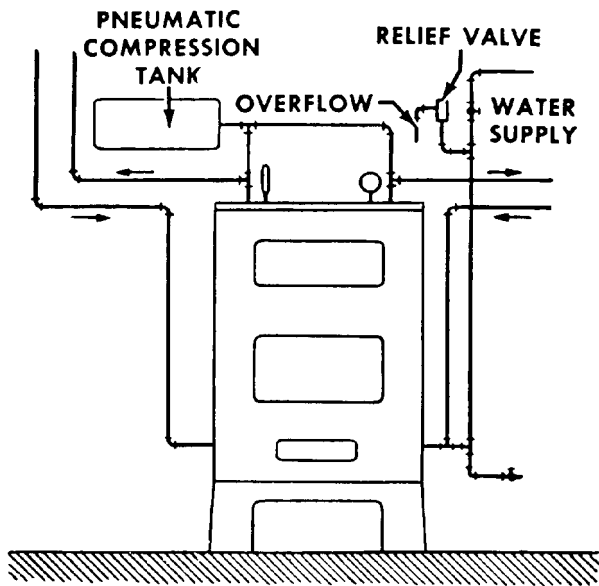

Figure 5-2. Closed tank gravity system.

e. *Boiler drain and cleanout openings.* The low point in the system has a boiler drain valve and the boiler is provided with rod-out openings so all sediment, rust, and the like can be flushed out readily.

**5-3. Startup.**

Close all vents, open all radiator valves, and open the water supply valve allowing water to flow until the expansion tank is approximately half filled or until water runs out of the overflow connection. Beginning with the lowest radiators, open vent valves to remove air. Hold a small pail at each vent and close the vent valve when free flow of water

occurs. It may be found necessary to add water to the system to enable venting of all radiators as the procedure progresses. A new system should be drained and refilled several times before starting the fire to remove grease, core sand, and other foreign material. In the initial firing of a newly filled system, it is advantageous to bring the system up to temperatures considerably in excess of anticipated operating temperatures. This will tend to expel entrained air from the system water and thoroughly vent the system at start which will eliminate future difficulties due to air pockets. After a new system is in operation for a short period, open boiler drains, since heavy core sand and similar materials have a tendency to flow to this low part of the system. When opening drains and feeding make-up water to a hot water heating system in operation, be careful that flow is not too fast. Otherwise, excessive stress will be set up in the boiler structure due to excessive temperature changes. After the system has been fired approximately 10 days, open air vents again and release air from radiators. Check the system periodically for venting requirements.

**5-4. Water level.**

Probably the most important consideration in operating a hot water system is maintaining the proper water level in the expansion tank. Frequent observation of the water level should be made. The water level should be low enough in a cold system to allow ample space for heated water to expand.

**5-5. Inspection and maintenance.**

Operating difficulties of gravity systems are negligible, and corrective measures are seldom required. Air which may accumulate in radiators should be vented periodically to assure consistent heating system performance. If rapid fluctuation or pulsation of pressures should occur, check for system leaks, stoppages and relief valve operation. When a system is to be removed from service, drain the system completely to remove accumulated sediment, rust, etc., and refill with clean water.

**Section II. FORCED CIRCULATION SYSTEMS**

**5-6. General.**

a. Forced circulation system piping and equipment (figure 5-3) is similar to that of gravity flow systems, except that pipe and equipment sizes are generally smaller due to increased flow velocities. The general arrangement of the forced flow system

differs from the gravity flow type only in that a pump is installed at the termination of the return piping near the boiler. Advantages of using a pump to produce the circulation are that much smaller pipes are required and positive circulation is assured throughout the system.

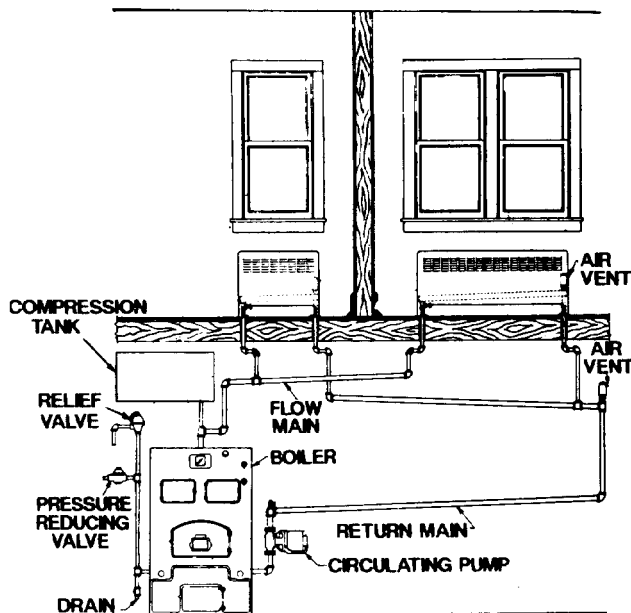

Figure 5-3. Forced circulation system.

b. There are some essential differences in circulation in a forced circulation system as compared with a gravity system. It is necessary to understand what takes place in order to remedy problems that may be encountered in the field. The most important difference is that in the forced circulation system, the circulating force, neglecting gravity effect, is produced locally by the pump. In the gravity system, the circulating force is produced uniformly throughout the system in the vertical runs of piping. A second difference is that the self-regulating property of a gravity system is almost lacking in the forced circulation system. Therefore, if pipe size and radiator connections in the forced circulation system are greatly restricted at some points or improperly sized and balanced for uniform flow, the effect is likely to be serious.

### 5-7. Equipment.

The principle equipment of a forced circulation system includes a boiler or heat exchanger, radiators or fan-coil units, one or more circulating pumps, an expansion tank, a relief valve, a hand or automatic fill valve to maintain set system pressure, and appropriate controls for pump operation and automatic firing equipment.

a. *Hot water pumps.* Circulating or booster pumps are usually of the centrifugal type and are installed in the pipe line with flanged fittings. In a system that includes only one pump, each return line is connected to a common pump inlet header through a square-head cock to enable balancing of the system by equalizing return temperatures from various circuits. In large installations immersion

thermometers are placed in the return or provisions are made for inserting immersion type test thermometers near the pump. Circulation pump rotation should be checked to make certain that rotation is in the proper direction. Location of the pump in the return line is suitable for small systems where pump head is low, as in most residential systems. Larger systems require the pump on the supply side of the boiler, with the expansion tank connected to the pump inlet.

b. *Expansion tanks.* Forced circulation hot water systems almost always employ closed expansion tanks. Since a closed expansion tank is sealed against free venting to the atmosphere, the tank may be above the highest radiator or heat transmitter, or may be below the lowest one. The minimum volume of a closed expansion tank is such that expansion of water due to an increase in temperature is cushioned against a reservoir of compressed air above the water level in the tank. The tank provides space not only for changes in water volume, but also for variations in air volume within the tank due to changes in air pressure. If the closed expansion tank is below the radiators, the tank is larger than if it is above them. The higher the building the larger the air capacity should be within the tank in excess of that required for increase in water volume due to an increase in temperature. The closed expansion tank should be located above the highest heat transfer surface in tall buildings. A closed expansion tank located above heat transfer surfaces of a hot water heating system should be connected by a direct pipe to the flow main leaving the boiler in order to enable air to migrate easily to the expansion tank. In a closed hot water heating system, water tends to absorb air at a rate which increases with an increase in pressure and decreases with an increase in temperature. Means should be provided to adjust and to observe the proportion of air within any closed expansion tank. This includes provision of an air inlet valve, a water gauge, and a relief valve. A source of compressed air for renewing the air cushion is highly desirable, especially in large, high pressure hot water heating systems where it is inconvenient and impractical to drain water in the system to permit introduction of air.

c. *Relief valves.* All hot water heating systems require proper provision for pressure relief. Equipment can be subjected to excessive pressure by expansion of confined water in the system if: connections to expansion tanks are closed due to freezing or other stoppage causes; the system's expansion tank becomes completely filled with water or; the air volume is inadequate to allow for necessary expansion. A conventional type hot water pressure relief valve which employs a spring-loaded dia-

phragm to raise a valve seat when water pressure exceeds 30 psig is installed in each system. This valve is located in the cold water supply line between the boiler and the reducing valve. The conventional reducing and relief valve installation does not provide adequate protection for systems in which radiators are at boiler level as in a single story building without a basement where the boiler is installed at grade level in a utility room or similar location. Where radiators are at boiler level, instead of the conventional make-up water connection, an automatic water line regulator is installed in the vertical riser between the main boiler take off and overhead expansion tank. The relief valve is located in the vertical riser at the water line of the regulator.

d. *Reducing valves.* A reducing valve in the make-up or cold water line to the boiler automatically keeps the closed system supplied with water at the predetermined safe system pressure. The valves are usually factory set at 12 psig pressure, which is equivalent to a static head of 27.6 feet of water, suitable for buildings up to three stories high. The valves can be reset for higher pressures if desired. Thirty (30) psig is the maximum for

standard hot water heating system equipment, and the reducing valve setting should be kept as low as possible. The valve should be located at approximately the same level as the top of the boiler.

**5-8. Piping systems.**

Forced circulation hot water heating systems generally use two-pipe systems. The two-pipe system has two mains: the supply main which feeds water to the risers that serve the heating units, and the return main which collects the water returned from those units. The two mains run side by side; the supply main decreases and the return main increases in size where the branches connect. Since the heating units of a two-pipe system are connected in parallel, a minimum pumping head is required. Also, if throttle valves or restricting orifices are used in the risers, the flow through individual units can be adjusted easily over a wide range. The two-pipe system, however, requires more pipe and fittings than the one-pipe system. Two pipe systems may be classified as either direct-return or reverse-return depending on the direction of the return (figure 5-4).

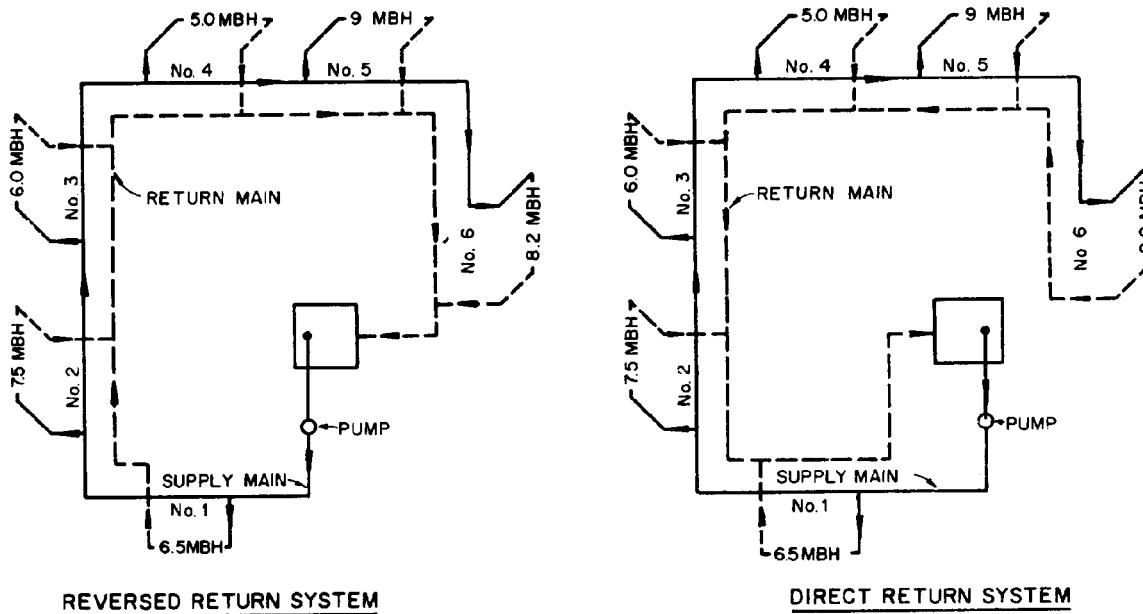

Figure 5-4. Two-pipe distribution system.

a. *Direct return systems (figure 5-4.2).* The heating units of the two-pipe, direct return system are in parallel. Water taken from the main to feed the first unit is returned first; that removed for the second unit is returned second; and so forth throughout the heating units. Since this procedure causes a progressively greater friction loss in addi-

tional circuits, the flow circuits are hydraulically unbalanced. This condition may cause the first unit to have a greater flow than is required to develop its full capacity, while, in a large system, flow through the last unit may be so small that practically no heat is delivered. Restricting orifices or throttle valves are sometimes used to correct

flow distribution and to balance the system after it is placed in service.

*b. Reversed return systems (figure 5-4.1).* In the two-pipe reversed-return system, water taken from the main to feed the first unit is returned last to the return main; the water supplied to the last unit is returned first. As a result, all unit circuits are approximately equal in length, a condition conducive to system balance. The reversed return system may require more pipe than the direct return; however, its inherently better flow distribution and natural balance without the aid of additional valves or orifices, compensate for the additional cost.

*c. Series-loop systems (figure 5-5).* A series-

loop system may have one or more loops or circuits. All the heating units in a circuit are installed in series and the same amount of water flows through each and through the connecting main. For a given available head, the length of the circuit and the number and type of heating units determine the water flow rate and temperature drop. The water temperature decreases progressively as the water flows through each successive heating unit. Series systems are frequently used in connection with baseboard radiation. Neither the flow nor the temperature of the water supplied to individual heating units can be regulated in this system. Delivery of heat, therefore, is usually controlled by air dampers in the baseboard radiation cabinets.

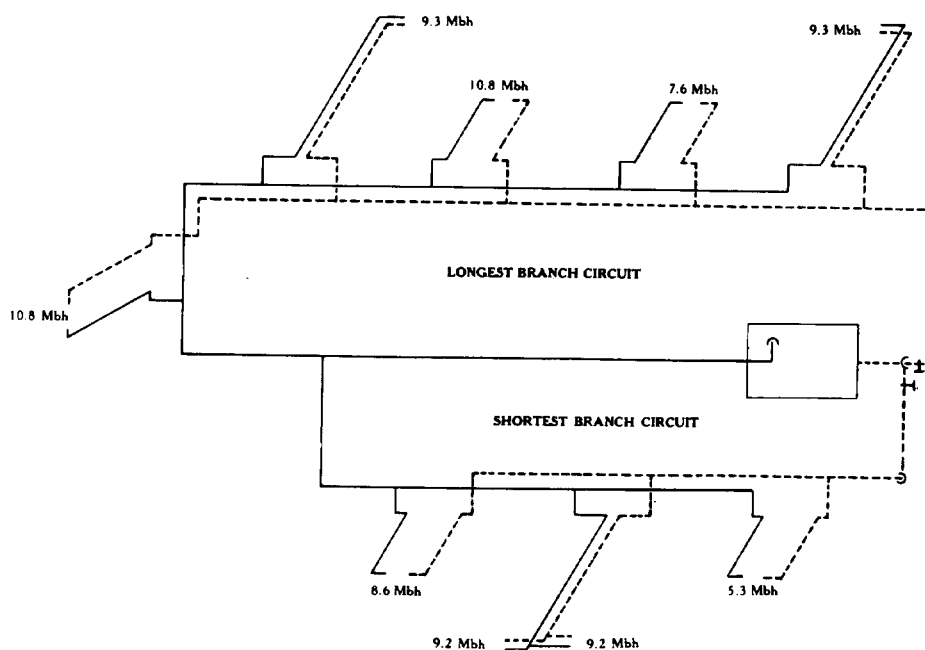

Figure 5-5. Series loop distribution system.

### 5-9. Inspection and maintenance.

Generally, a good hot water heating system rarely presents operating difficulties if temperatures and pressures are kept within normal ranges. If rapid fluctuation or pulsation pressures should occur, check for system leaks, stoppages, and relief valve operation. The indicated pressures of a closed system may increase slightly with the increase of water temperature. Each system has its own definite increase characteristic, determined by the water

capacity of the system and the size of the expansion tank. Observe and record this characteristic when the system is in perfect operating condition. Any later deviations from the established pressure may indicate that the water level is low (if pressure decreases) or that the system is stopped or plugged (if the pressure is above normal). When a system is to be removed from service, drain the system completely of accumulated sediment, rust, and the like, and refill with clean water.



Section III. HOT WATER FAN-COIL UNITS

5-10. General.

a. Basic elements of fan-coil units are a finned-tube coil and a fan section (figure 5-6). The fan section recirculates air continuously from within the space through the coil which contains hot water. The unit may also contain chilled water or an electric resistance, steam, or hot water type of heating coil. A cleanable or replaceable low efficiency filter is located upstream of the fan. This filter prevents the coil from becoming clogged with dirt or lint entrained in the recirculated air. It also protects the motor and fan, and reduces the level of airborne contaminants within the conditioned space. The unit is equipped with an insulated drain pan. The fan and motor assembly is arranged for quick removal to facilitate servicing. Ventilation air boxes with a dampered opening for connection to openings in the outside wall are optional.

b. Room fan-coil units are available in a number of physical configurations. Figure 5-7 show several arrangements of vertical wall mounted units and a horizontal ceiling mounted model. Low vertical units are available for use under windows with low sills; however, in some cases the low silhouette is achieved at a compromise of such features as filter area, motor serviceability, and cabinet style.

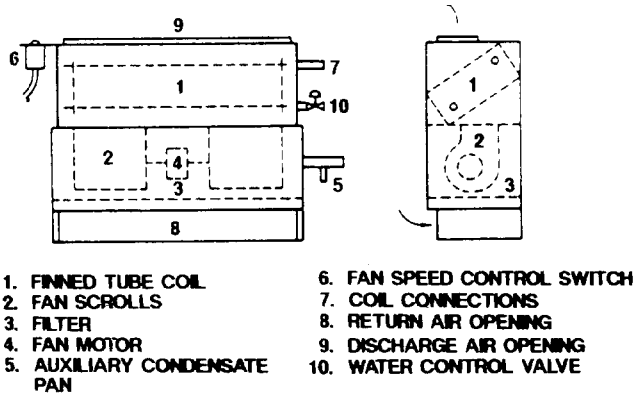

Figure 5-6. Typical fan-coil unit.

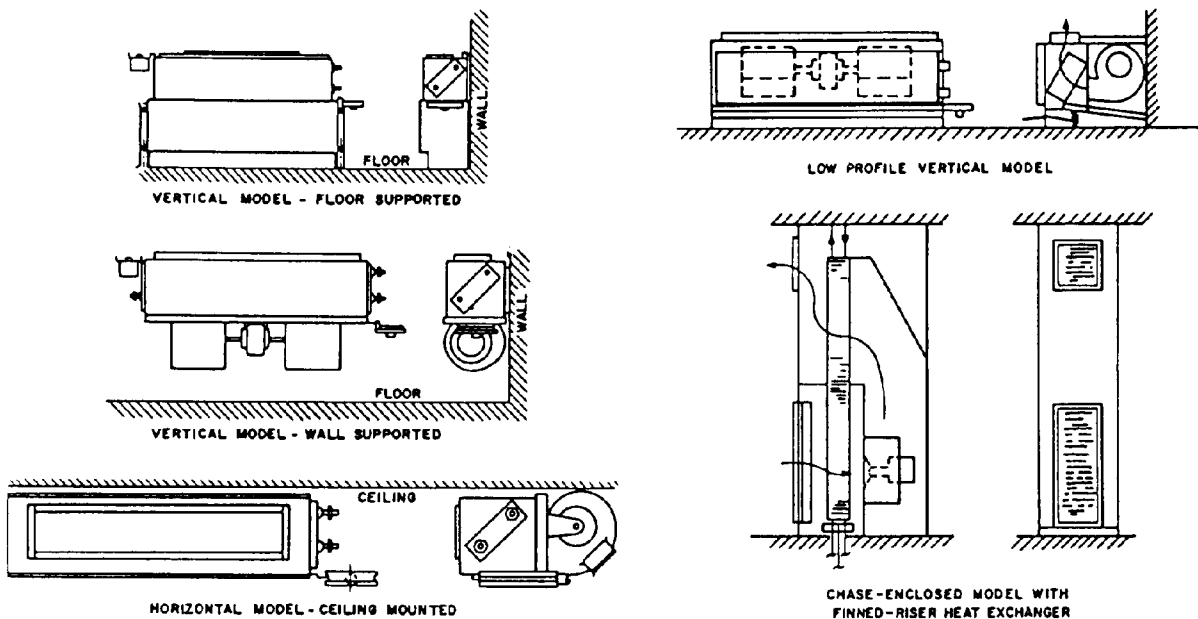

Figure 5-7. Typical fan-coil unit arrangements.

c. Floor-to-ceiling chase-enclosed units are available in which the water and condensate drain risers are part of the factory furnished units. If the riser is located in the partition between two rooms, both rooms can be served by the same unit. One style combines the water risers and coil into one assembly by finning a portion of the water riser. Water flow is continuous through all units and air bypass room temperature control is used. A limitation of this style of unit is the size of the finned riser; usually only 10 or 12 floors can be stacked on a common riser. Another style of floor-to-ceiling unit overcomes this limitation by using a separate coil which is sized independently of the risers.

d. Horizontal overhead units may be fitted with ductwork on the discharge to supply several outlets. A single unit may serve several rooms, e.g. in an apartment house where individual room control is not essential and a common air return is feasible. High static pressure units with larger fan motor handle the higher pressure drops of units with ductwork.

### 5-11. Fan coil capacity control.

a. Fan coil unit capacity can be controlled by coil water flow, air bypass, fan speed, or a combination of these. Water flow can be thermostatically controlled by either return air or wall thermostats. Modulating valves provide superior temperature control. Two-position valves cost less and provide superior dehumidification.

b. Water control valves should not be used where aperture outdoor intakes are used, unless there is a provision for freeze protection. Capacity control is achieved in certain configurations, by modulating a damper to bypass all or part of the air around the unit coil.

c. Fan speed control may be automatic or manual. Automatic control is usually on-off with manual speeds selection. Some units are equipped with variable speed motors for modulated speed control. Room thermostats are preferred where fan speed control is used. Return air thermostats will not give a reliable index of room temperature when the fan is off.

d. If horizontal units are installed, air velocity must be maintained to reach (throw) to the outside wall area, and manual readjustment of fan speed may be undesirable.

### 5-12. Electrical requirements.

a. Fans in these units are driven by small motors generally of the shaded pole or permanent split capacitor (PSC) type, with inherent overload protection. Operating wattage of even the largest sizes rarely exceeds 300 watts at the high speed setting. Running current rarely exceeds 2.5 amps. Almost all of the motors on units sold in the U.S. are wired for 115 V, single phase, 60 Hz current, and provide multiple (usually three) fan speeds and an off position. Voltage supply varies with each country, with 50 Hz current being quite common.

*b.* Separate electrical circuits, connected to a central panelboard, enable the building operator to turn off unit fans from a central point during unoccupied hours. While this results in a higher first cost, it offers operating cost advantages in buildings that do not have 24-hour per day occupancy. Use of separate electrical circuits is advantageous in applying a single remote thermostat mounted in a well exposed perimeter space to operate unit fans, if the setback temperature cannot be maintained with gravity heating. Connection of the fan-coil units into the lighting circuit serving the space results in a lower first cost and is satisfactory where air conditioning is being added to existing buildings.

### 5-13. Maintenance.

*a.* Room fan coil units are equipped with either cleanable or throw-away filters, which should be cleaned or replaced when dirty. Good filter maintenance improves sanitation and cleanliness and

assures full air flow through the unit and hence full capacity. The frequency of cleaning will vary with the application. Units installed in housing facilities and hospitals usually require more than normal filter service due to the presence of lint. Adhesive coated filters are not advisable if unit fans can be off for extended periods during the heating cycle. Heat radiated to filters during these periods can cause vaporization of the adhesive, resulting in objectionable odors.

*b.* Fan coil unit motors require periodic lubrication. Motor failures are uncommon, but when they occur it is possible to quickly replace the entire fan deck, with little interruption within the conditioned space. The defective motor can then be repaired or replaced in the maintenance shop. The condensate drain pan and drain system should be periodically cleaned or flushed to prevent overflow. The airside of the coil should be cleaned annually.

## Section IV. HEAT EXCHANGERS

### 5-14. General.

The term heat exchangers is usually applied to a device in which two fluid streams, separated by a solid surface, exchange heat energy. These devices may take many forms. However, ordinary metal tubes are the main components of many types. Heat exchangers in hot water systems can use steam or high temperature hot water from a central plant to generate the low temperature water needed for the heating systems.

### 5-15. Installation.

*a.* Provide sufficient clearance at the stationary tube sheet end of the unit to permit removal of tube bundles from shells. On the packed floating tube sheet end, a space of 3 or 4 feet should be provided to permit the removal of the rear head, packing and retainer rings.

*b.* Provide valves and bypasses in the piping system so that both the shells and tube bundles may be bypassed to isolate the unit for inspection or repairs.

*c.* Provide a thermometer well and pressure gauge connection in all piping to and from the unit and locate as near the unit as possible.

*d.* Provide necessary air vent cocks for units so they can be purged to prevent or relieve vapor or gas binding of either the tube or the shell sides.

*e.* Foundations must be adequate so that exchangers will not settle and cause piping strains. Foundation bolts should be set to allow for setting inaccuracies. In concrete footings, pipe sleeves at

least one size larger than bolt diameter slipped over the bolt and cast in place are best for this purpose, as they allow the bolt center to be adjusted after the foundation has set.

*f.* Loosen foundation bolts at one end of unit to allow free expansion of shells. Oval holes in foundation brackets are provided for this purpose.

*g.* Set exchangers level and square so that pipe connections may be made without forcing.

*h.* Inspect all openings in exchanger for foreign material. Remove all wooden plugs and shipping pads just before installing. Do not expose units to the elements with pads or other covers removed from nozzles or other openings since rain water may enter the unit and cause severe damage due to freezing.

*i.* Be sure entire system is clean before starting operation to prevent plugging of tubes with sand or refuse. The use of strainers in settling tanks in pipe lines leading to the unit is recommended.

*j.* Drain connections should not be piped to a common closed manifold.

*k.* Water hammer can cause serious damage to the tubes of any heat exchanger. A careful consideration of the following points before an installation is made can prevent costly repairs which may be caused by water hammer.

(1) A vacuum breaker and/or vent, should be used in accordance with the type of steam system installed.

(2) The proper trap for the steam system installed should be used.

(3) The trap and the condensate return line to the trap should be properly sized for the total capacity of the convertor.

(4) The trap should be sized for the pressure at the trap, not the inlet pressure to the steam control valve.

(5) Condensate should be piped and pitched to the condensate receiver, condensate return pump or drain at an elevation below the heat exchangers. **CAUTION:** During times of shut down, volumetric expansion can occur. Therefore, the installation of a properly sized valve on the heated side of the exchanger, is essential.

### 5-16. Operation.

*a.* When placing a unit in operation, open the vent connections and circulate the cold medium only. Be sure that the passages in the exchanger are entirely filled with the cold fluid before closing the vents. The hot medium should then be introduced gradually until all passages are filled with liquid, then close vents and slowly bring the unit up to temperature.

*b.* Start operation gradually. Do not admit hot fluid to the unit suddenly when empty or cold. Do not shock unit with cold fluid when unit is hot.

*c.* In shutting down, flow of hot medium should be shut off first. If it is necessary to stop circulation of the cooling medium then the circulation of hot medium should also be stopped by bypassing or otherwise.

*d.* Do not operate equipment under conditions in excess of those specified on the name plate.

*e.* Drain all fluids when shutting down to prevent freezing and corrosion. To guard against water hammer, condensate should be drained from steam heaters and similar apparatus both when starting up and when shutting down.

*f.* In all installations there should be no pulsation of fluids since this causes vibration and strain with resulting leaks.

*g.* All gasketed joints should be checked for

leaks and tightened if necessary soon after starting.

### 5-17. Maintenance.

*a.* Do not open heads until all pressure is removed from the system and the the heat exchanger is drained.

*b.* Do not blow out heat exchangers with air when fluids normally handled are inflammable.

*c.* To clean or inspect inside of tubes, remove channel cover and rear head. On exchangers having bonnet type heads (without channel cover), piping must be disconnected and both heads removed.

*d.* Exchangers subject to fouling or scaling should be cleaned periodically. A light sludge or scale coating on the tube greatly reduces its effectiveness. A marked increase in pressure drop and/or reduction in performance usually indicates cleaning is necessary, unless air or vapor binding is the cause of the problem. Since the difficulty of cleaning increases rapidly as the scale thickens or deposit increases, the interval between cleanings should not be excessive. Cleaning should be performed as follows:

(1) Circulate hot wash oil or light distillate through tubes or shell at good velocity to remove sludge or other similar soft deposits.

(2) To remove soft salt deposits, wash out by circulating fresh hot water.

(3) Special cleaning compounds are available for removing scale or sludge, provided hot wash oil or water, as described above, does not give satisfactory results. These cleaning compounds, especially those containing acid, must be thoroughly rinsed from the heat exchanger after cleaning or rapid corrosion may result.

(4) If none of the above described methods are effective for the removal of hard scale or coke, use a mechanical means for cleaning, such as tube scraping.

(5) Do not attempt to clean tubes by blowing steam through individual tubes. This overheats the tube causing expansion strain and possible tube leakage.

## Section V. ENERGY CONSERVATION

### 5-18. Hot water temperature reduction.

In addition to energy savings through the proper installation and maintenance of piping and equipment insulation, heat losses can be further reduced by reducing the hot water temperature to the minimum value required by the heating load and

distribution heat losses. The hot water supply temperature should be reset (manually or by automatic control) proportional to the heating demand. Once other energy conservation measures have been implemented, the maximum hot water temperature requirement should be established by reducing the temperature step-wise during periods of

## TM 5-642

maximum heating demand and noting the effect upon space temperatures. With this maximum temperature established, a linear reset schedule can be determined by noting the outdoor temperature corresponding to zero heating demand. Shut down boilers and heat exchangers completely whenever the outside temperature exceeds 65 F.

### **5-19. Night setback.**

Setting back space temperatures at night will save

a significant amount of energy. In large buildings with a central hydronic heating system, setback is usually performed by reducing the supply temperature from the boiler or heat exchanger at night. Another method of night setback uses a thermostat located in a part of the building which roughly represents the temperature of the entire building. This thermostat cycles the boiler or reduces supply temperature to maintain the desired setback temperature throughout the building.

## CHAPTER 6

## WARM AIR SYSTEMS

## Section I. DESCRIPTION OF SYSTEMS

**6-1. Warm air furnaces.**

The primary function of a warm air furnace is to burn fuel efficiently and to transfer the heat generated to the circulating air of a warm air heating system. Most furnaces consist of a combustion chamber (primary heating surface). The furnace may be cast iron, steel, or a combination of the two. The heat transfer per unit area of heating surface is essentially the same for cast iron and steel where both are operated at the same temperature difference. With either cast iron or steel, thicker material yields longer life without materially affecting heat transfer. The furnace may be fired with any of the common fuels and may be of the gravity or forced air type. Gravity warm air furnaces depend upon convection currents to obtain the head required to produce the airflow; forced air furnaces produce the necessary airflow with fans or blowers and are usually equipped with air filters.

**6-2. Gravity warm air heating systems.**

Operation of gravity warm air heating systems is dependent upon the difference in density (weight) of warm and cold air. Warm air is less dense (lighter) than cooler air and will rise if cooler air is available to displace it. Satisfactory operation of a gravity warm air heating system depends upon three interrelated factors: size and "pull" of the air ducts; building heat loss and; the heat available from the furnace.

*a. Ducted gravity systems.*

(1) In a ducted gravity system (figure 6-1), warm air is conveyed from the furnace bonnet (top section of the furnace casing), through metal ducts, to the spaces to be heated. Vertical ducts (stacks) connect with registers usually installed in room baseboards, floors, or sidewalls just above the baseboards. Stacks are generally located within inside partitions to prevent chilling of the supply air and consequent reduction in head; cooled air return registers may be located in either cold or warm walls, but cold walls are preferred (unless a long, high-friction-loss duct is required). Gravity warm air systems often have only one or two centrally located return registers, all on the first floor. Upstream of the furnace casing, return ducts usually join a single large duct which enters the casing near the floor or furnace foundation. This

connection is made below all parts of the furnace which radiate enough heat to cause a countercurrent of warm air, because such a current opposes the flow of cooled air into the furnace.

(2) The most common source of trouble in gravity systems is insufficient duct area, usually in the cold air (return) duct. The total cross-sectional area of the cold air duct(s) must be at least equal to the total cross-sectional area of all warm air (supply) ducts. If it is necessary to supply additional heat to a space at the end of a long duct run, this can be accomplished by throttling the balancing dampers in other supply ducts to favor the deficient area or installing a booster fan in the deficient duct to force the air stream.

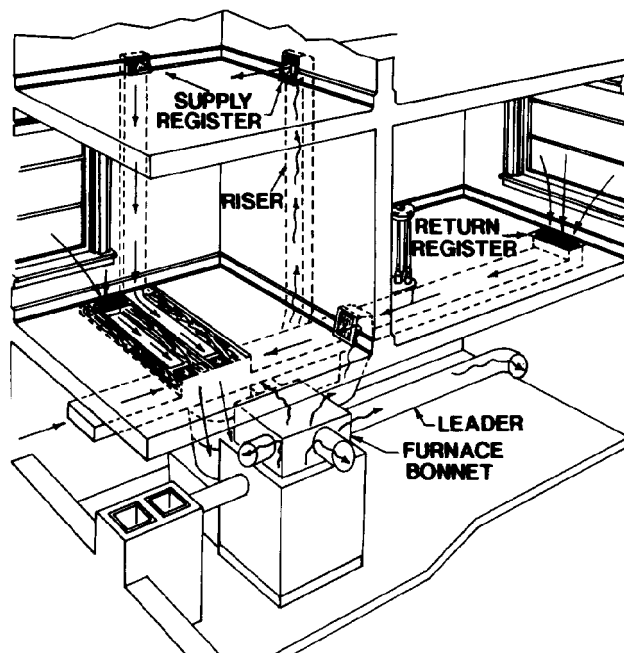

Figure 6-1. Simple gravity warm air heating system.

*b. Ductless gravity systems.* Ductless gravity furnaces are often installed on floor level; they are simply oversized jacketed space heaters. The most common difficulty experienced with this type of furnace is a return air opening (at the floor) of insufficient area. The return air opening should be made on two or three sides wherever possible. Insulation should be provided above the furnace to avoid possible fire hazards.

**6-3. Forced warm air heating systems.**

The principal of operation of forced air heating systems differs from that of gravity heating systems in that a fan or blower is included in the former to insure and regulate air movement. Due to the assistance of the fan, duct pitch can be disregarded

allowing the most convenient duct runs to be installed. Figure 6-2 shows a typical forced air heating system. In addition to the prime movers (fans), the components of a forced air heating distribution system include supply and return ducts, registers, dampers, and insulation.

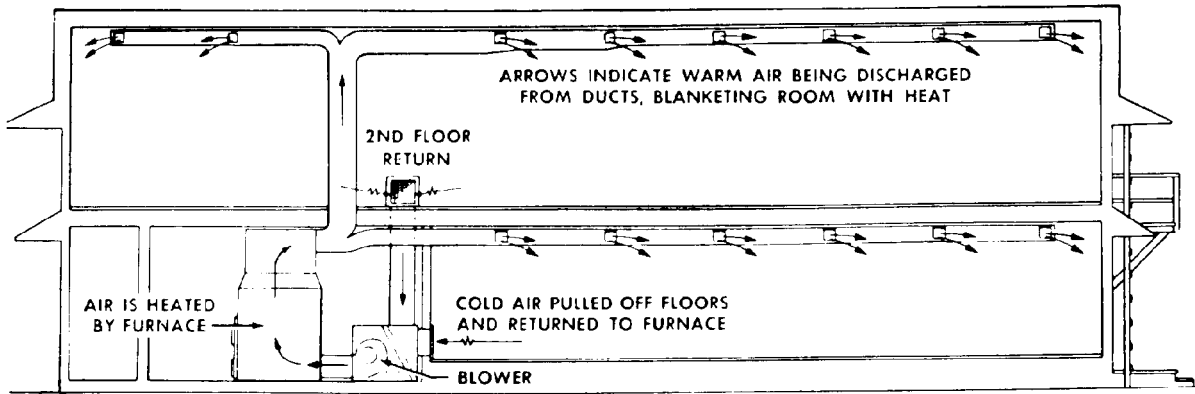

Figure 6-2. Forced warm air heating system.

a. *Outside wall delivery system.* In this system, supply grilles are located along the outside (perimeter) walls, near the sources of greatest heat loss. These supply grilles (or registers) are designed to blanket the perimeter areas and mix with the cold air from infiltration points thereby reducing or eliminating discomfort due to drafts.

b. *Central fan delivery system.* This system (figure 6-3) sometimes performs both heating and ventilation functions in large buildings. The air heaters in this system are heat exchangers consisting of pipe coils, finned tubes, or cast iron sections connected into stacks or units by nipples. The intermediate heat carrier is either hot water or steam (from boilers, convertors, etc.) circuited through the heating elements of the heat exchanger. A fan blows (or draws) air through the air heater and supplies it to the spaces to be heated through the distribution ductwork. Because the amount of air required for heating purposes usually exceeds that required for ventilation, economy of operation is improved by recirculating a portion of the heated air. A common central fan delivery system includes the following:

(1) *Outside air inlet duct.* This duct is fitted with a damper to control the influx of outside air to

the heated area. The damper may be modulated or fixed in position.

(2) *Air filter.* An air filter is located in the inlet air duct, just upstream of the air heater.

(3) *Return air damper.* A return air damper, installed upstream of the air filter, permits a regulated recirculation of heated air into the outside air inlet duct. The combined operation of this damper and the outside air damper (which controls the influx of cold air) provides for tempering the outside air introduced into the system.

(4) *Air heater.* The air heater (a heat exchanger heated by steam or hot water) is located in the mixed air duct, downstream of the air filter.

(5) *Fan.* A motor operated fan, located after the air heater, draws the tempered air through the heat and discharges it to a trunk line. "Blow-through" arrangements locate the fan upstream of the air heater.

(6) *Trunk line.* This is a main duct with individual branches taken off at intervals to carry the tempered air to the required spaces. Dampers at either the branch take-off points or the branch outlets provide balanced air distribution. The duct may be made from galvanized steel sheets; both aluminum and non-metallic ducts also are used extensively.

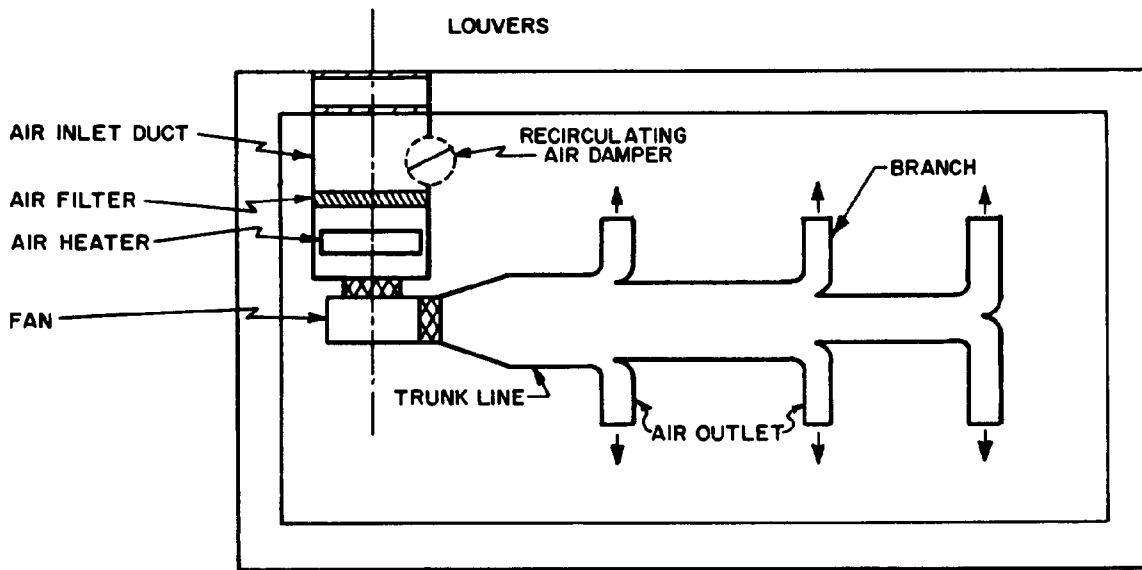

Figure 6-3. Central fan heating system.

c. *Perimeter delivery systems.* Perimeter systems usually employ the outside wall delivery system. Air returns to the furnace through centrally located, high sidewall or ceiling grilles. Return ducts may be located in attics or other unheated spaces. Return air may be taken from crawl spaces and basements, but never from a confined space in which the

furnace is located. In perimeter systems, a downflow furnace is normally used. In this type furnace, cold air enters the unit from above and is discharged as warm air from the bottom or lower part of the furnace casing. Figure 6-4 illustrates one type of perimeter system called a loop system.

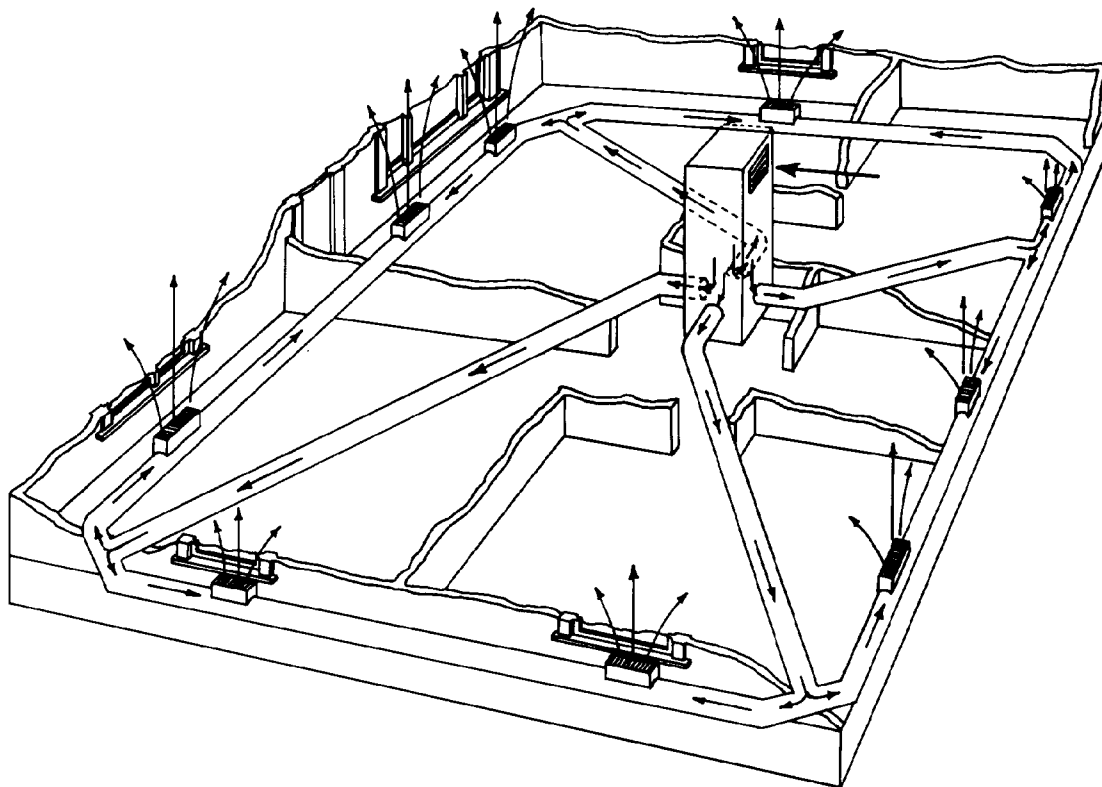

Figure 6-4. Perimeter loop delivery system.



d. *Inside wall delivery system.* Supply grilles are located on an inside (warm) wall, either high or near the floor. Return registers are located near the greatest exterior exposure. High wall registers deliver the air either horizontally or slightly downward, so that it does not strike the ceiling or wall. For best results, multi-directional grilles are used, distributing the airflow uniformly. To reduce the discharge velocity, grilles are used with an area larger than that of the connecting duct. Location of the warm air return grille depends on the location of the supply grilles.

e. *Ceiling delivery system.* This system employs ceiling diffusers to deliver the warm air to the de-

sired spaces. With annular ceiling diffusers, the airstream is spread a full 360 degrees and the rate of diffusion is high; however, the throw is rather short, requiring (or in some cases allowing) high air discharge velocities.

**6-4. Ratings of warm air furnaces.**

Furnace rating is usually determined by BTU delivery per hour at the bonnet. Standard ratings for different manufacturer's furnaces can be obtained from the various trade associations, depending upon the type of fuel fired by the furnace.

**Section II. COAL FIRED WARM AIR FURNACES**

**6-5. Steel furnaces.**

Steel furnaces (figure 6-5) are constructed of heavy gauge steel, riveted and caulked or welded at the joints to make them air-tight. The fire-feed, ashpit, and draft doors, usually made of cast iron, are located at the front of the furnace. In smaller sizes, steel furnaces usually have a single radiator

(secondary heating surface) attached to the rear of the combustion chamber. In large sizes, two additional radiators may be installed on the sides of the furnace. All radiators must have a cleanout opening. Steel furnaces are, in general, more common than cast iron furnaces on Army installations.

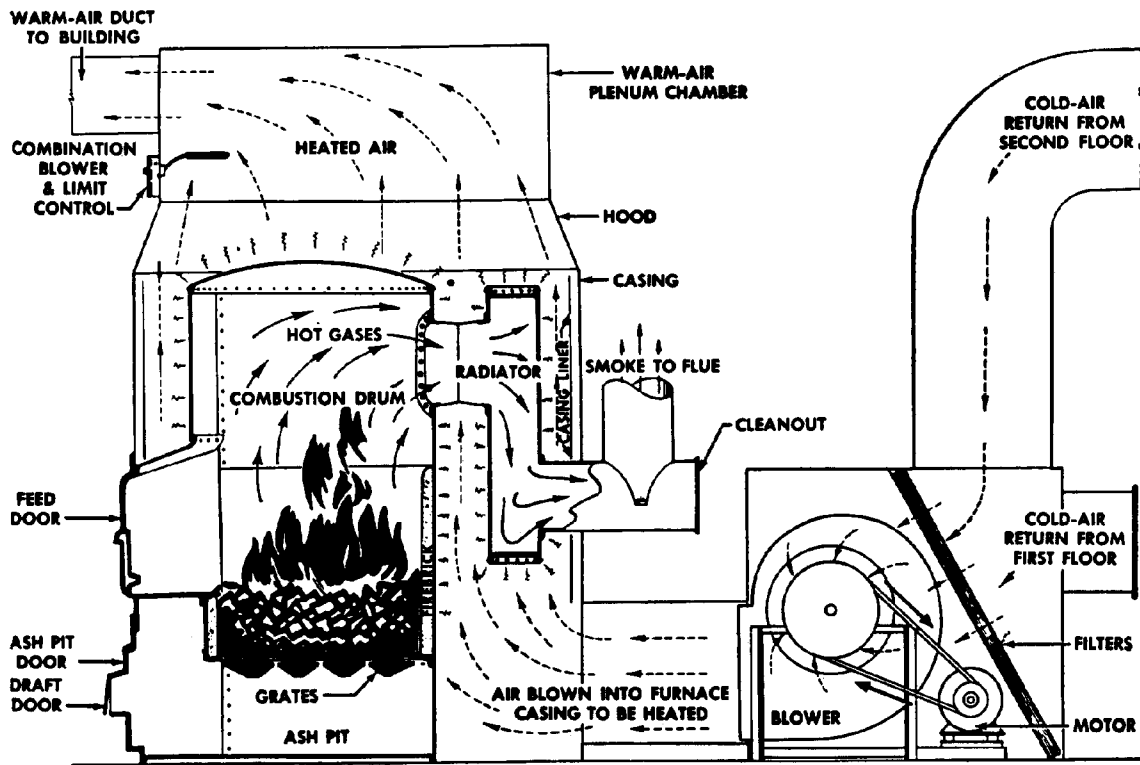

Figure 6-5. Coal fired steel forced warm air furnace.

**6-6. Cast iron furnaces.**

Cast iron furnaces are constructed in sections which are made airtight by the use of liberal amounts of furnace cement. Use cement supplied by the furnace manufacturer in a fashion consistent with the manufacturer's recommendations. The radiator (secondary heating surface) is usually located on top of the combustion chamber dome. Both steel and cast iron coal fired furnaces must be installed on a solid masonry base. Do not install on a base made with wood or other combustible material.

**6-7. Ratings and sizes.**

Ratings are determined by BTU per hour (BTUH) delivery at the bonnet. Standard code ratings are used in sizing coal fired furnaces, in accordance with the following formulas:

- a. *Furnaces with 294,000 BTUH or less output.*  

$$\text{BTUH output at the furnace bonnet} = [\text{area of grate in square feet}] \times [7.5 \text{ pounds of coal}]$$

$$\times [\text{BTU content per pound of coal}] \times [0.65 \text{ (efficiency)}]$$

- b. *Furnaces with more than 294,000 BTUH output.*

$$\text{BTUH output at the furnace bonnet} = [\text{area of grate in square feet}] \times [10.0 \text{ pounds of coal}] \times [\text{BTU content per pound of coal}] \times [0.70 \text{ (efficiency)}]$$

**6-8. Smokepipe.**

The smokestack from furnace to chimney must be 18 gauge or heavier steel, and at least as large (in cross-sectional area) as the furnace collar. Avoid the use of elbows wherever possible. Install the check draft used with bituminous or anthracite coal with hinges on the top sides of the smokepipe for easy (chain) operation by the damper motor. For buckwheat coal, a checkdraft is generally omitted, but a balanced atmospheric type damper should be installed to regulate chimney draft. (See figures 6-6 and 6-7.)

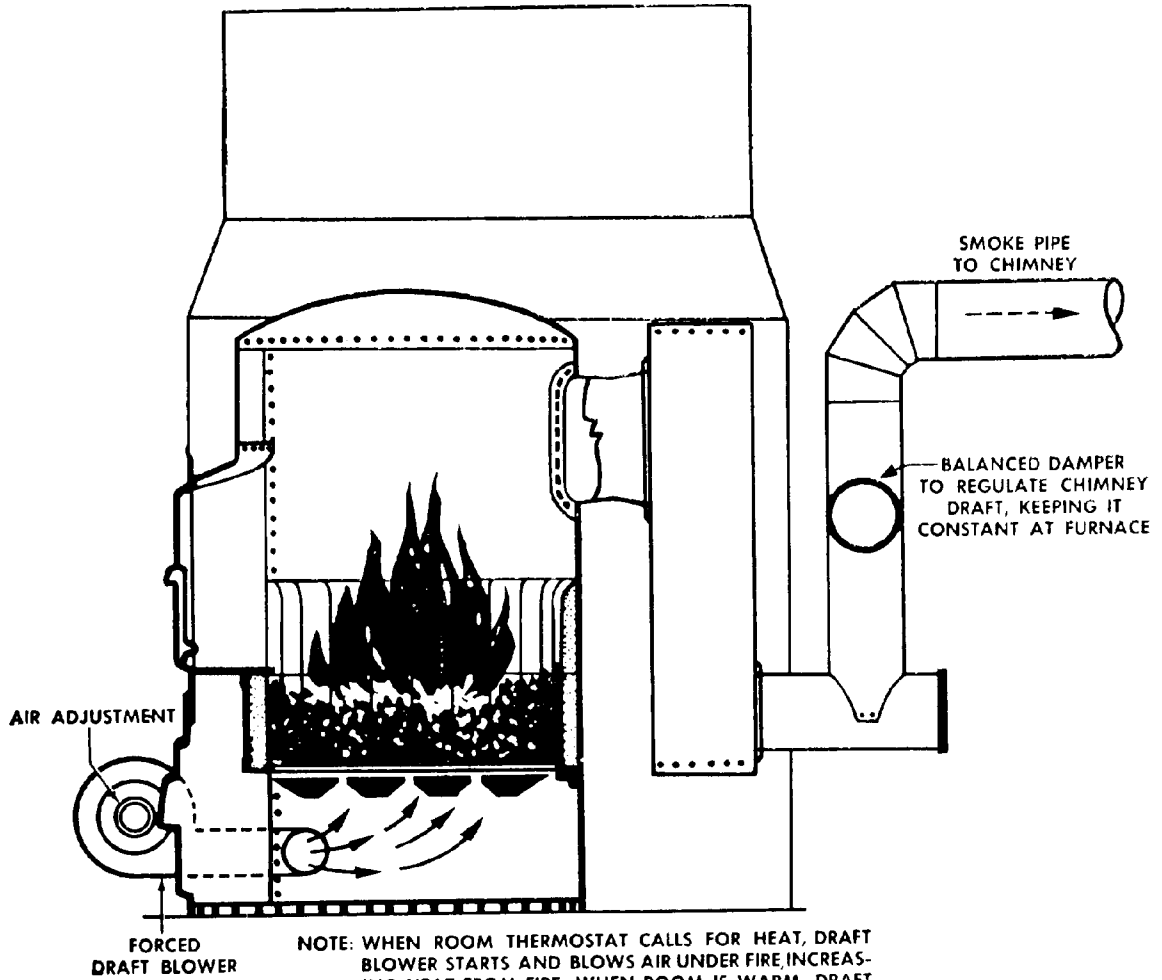

NOTE: WHEN ROOM THERMOSTAT CALLS FOR HEAT, DRAFT BLOWER STARTS AND BLOWS AIR UNDER FIRE, INCREASING HEAT FROM FIRE. WHEN ROOM IS WARM, DRAFT BLOWER STOPS AND FIRE COASTS IN A CHECKED CONDITION UNTIL THERMOSTAT AGAIN CALLS FOR HEAT.

Figure 6-6. Draft control for anthracite coal furnace.

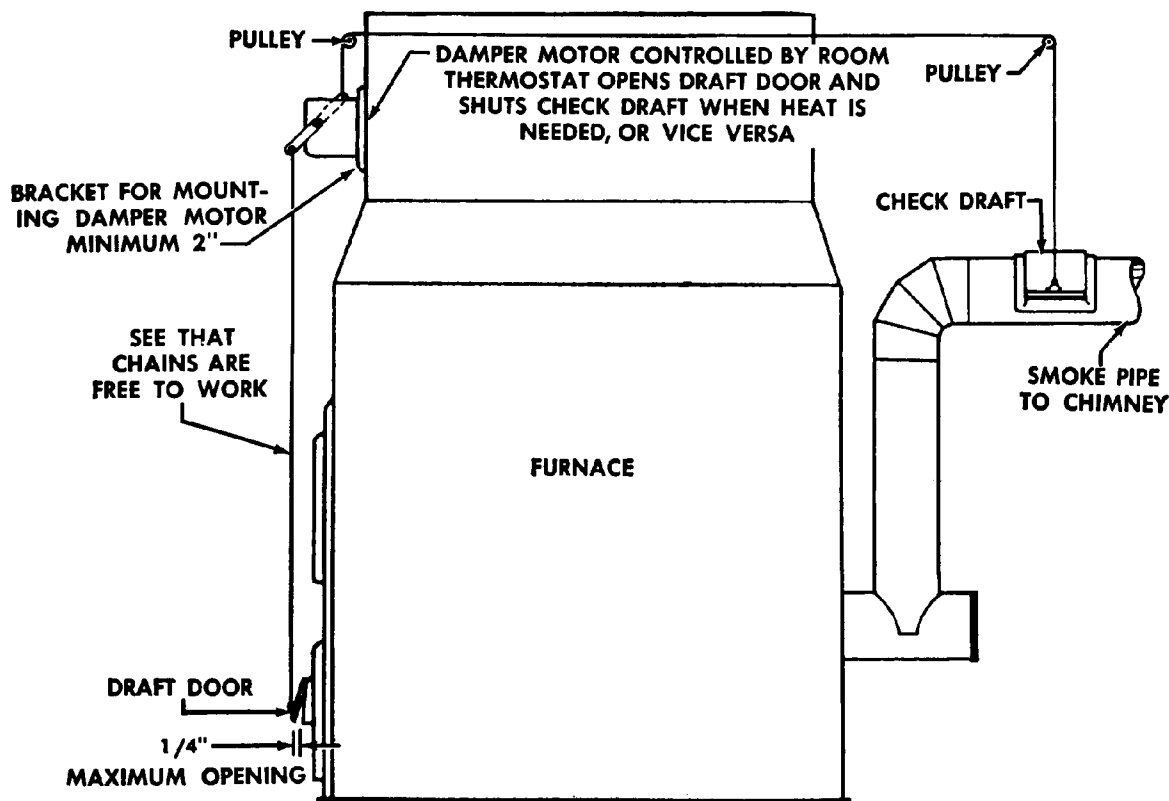

Figure 6-7. Draft control for bituminous coal furnace.

### 6-9. Motor damper.

Install the motor damper such that it has no direct contact with the furnace or bonnet. Motors installed on the bonnet or furnace are should be mounted on a bracket which extends out to allow for air passage, or are mounted on insulators to prevent excessive heating.

### 6-10. Chimney.

The importance of the chimney in the proper combustion of coal cannot be overemphasized. Every pound of coal requires from 150 to 250 cubic feet of air for proper combustion; sufficient draft must be maintained through the fuel bed to supply this amount of air. A blocked chimney or chimney downdraft can cause inadequate draft and therefore, incomplete combustion and create carbon monoxide. A chimney must have sufficient area and height, and must be tight from bottom to top. The most efficient chimney shape is round; however, because rectangular chimneys are commonly

used, particular attention must be given to them. Rectangular chimneys must be carefully checked, from the standpoint of both area and dimensions.

*a. Area.* A chimney must have a cross-sectional area greater than or equal to that of the smoke-pipe outlet from the furnace. The smaller dimension of a rectangular flue must be at least two-thirds of the smokepipe diameter. Chimney cross-sectional area must be increased 4 percent for each 1,000 feet of elevation above sea level.

*b. Height.* Follow manufacturer's recommendations on chimney height at all times. Height of the chimney may be 85 percent of the recommended height without requiring compensation; however, for each 10-percent decrease below recommended height, add 6 percent to the grate area to get the same furnace heat output (BTUH). All chimneys must extend at least 2 feet above the peak of the roof and in no cases should chimney height be less than 15 feet, even for small furnaces.

Section III. OIL FIRED WARM AIR FURNACES

6-11. General description.

Oil fired furnaces may be designed and built exclusively for use with fuel oil, or oil conversion burners may be installed in furnaces originally burning coal. Standard design and installation practices for fire prevention are detailed in the applicable codes, technical manuals, and manufacturer's literature.

6-12. Oil furnaces.

With oil furnaces, maximum efficiency (beyond that possible with oil conversion burners) is the result of proper sizing of the combustion chamber and the firepot volumes, longer heat travel, and very large heating surfaces. Oil furnaces are usually of the blowthru type, with an air space pressure greater than the combustion chamber pressure. Compact fan-furnace-burner units may be installed in basements, attics, or other locations with limited space. Figure 6-8 illustrates a typical oil fired furnace.

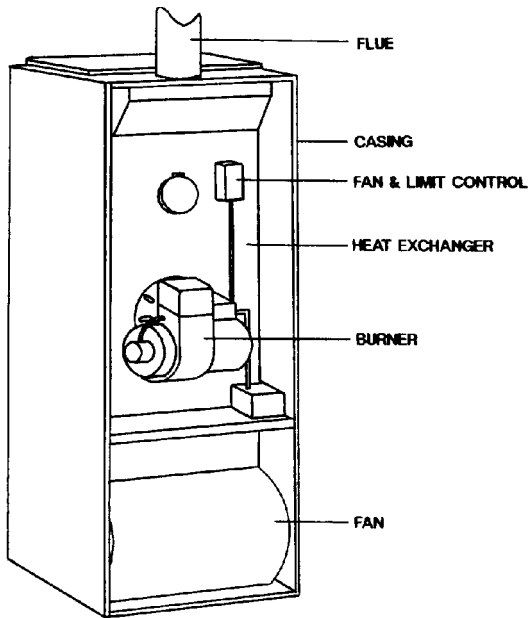

Figure 6-8. Typical oil fired furnace.

6-13 Oil conversion furnace.

Coal furnaces may be modified for oil firing capabilities by installing oil conversion burners in existing coal furnaces.

a. *Firepot.* The firepot may be either round or square. Normally, a 24-gauge sheet metal drum is set on a brick floor inside the furnace. The sheet metal acts as a retainer for the firepot wall. Bricks are cemented with special mortar, made for the particular brick used. The space between the firepot wall and the furnace body is not filled. Heat is allowed to flow behind the refractory pot. In gravity warm air installations, a radiation shield is installed between furnace body and casing to prevent radiant heat from retarding cold air circulation. Refer to figure 6-9 for typical firepot construction.

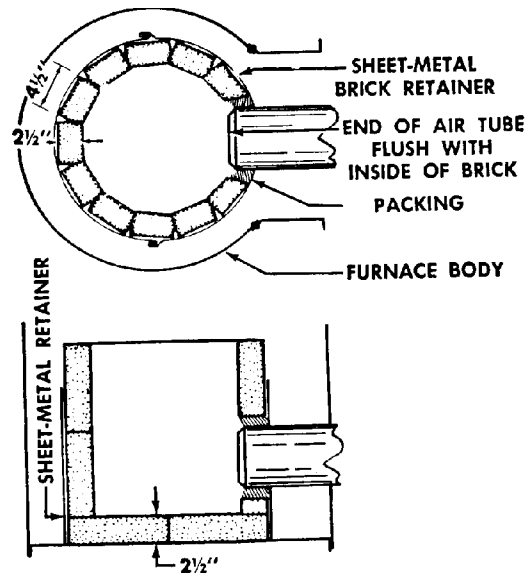

Figure 6-9. Typical firepot construction.

b. Oil conversion burner installation.

(1) Installing burner.

(a) Set burner with end of blast tube flush with the inside wall of the firepot. (See Table 6-1 and firepot diagrams, figures 6-10 and 6-11.)

Table 6-1. Recommended Firebox Sizes

Firing Rate (gph)	Round Firepot			Spray Angle (degrees)	Rectangular—Firepot			
	Size (in)				Size (in)			
	A	B	C		A	B	C	D
0.80	10.0	16.0	6.0					
1.00	11.0	18.0	6.0	80	9.5	9.0	6.0	14.0
1.35	13.0	18.0	6.0	80	12.0	10.0	6.0	14.0
1.50	14.0	18.0	6.0	80	12.5	11.0	6.0	18.0
1.75	15.0	18.0	6.0	80	14.0	12.0	6.0	18.0
2.00	16.0	18.0	6.0	60	15.0	13.0	6.0	18.0
2.50	18.5	18.0	6.0	60	17.0	15.0	6.0	18.0
3.00	20.5	18.0	7.0	60	19.0	16.0	7.0	18.0
3.50	22.5	18.0	7.0	60	22.0	17.0	7.0	18.0
4.00	24.0	18.0	7.0	60	26.0	19.0	7.0	18.0
4.50	26.0	18.0	8.0	60	29.0	20.0	8.0	18.0
5.00	27.5	18.0	8.0	60	32.0	21.0	8.0	18.0
5.50	29.5	18.0	8.0	60	36.0	22.0	8.0	18.0
6.00	31.0	18.0	8.0	60	40.0	23.0	8.0	18.0

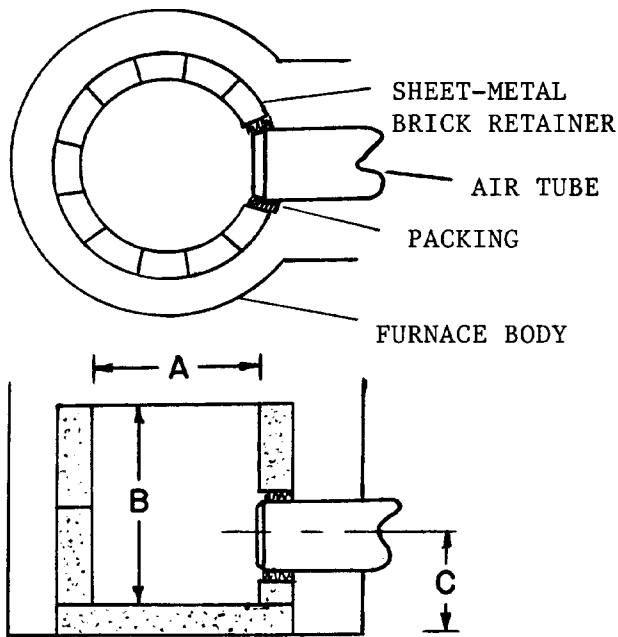

Figure 6-10. Round firepot.

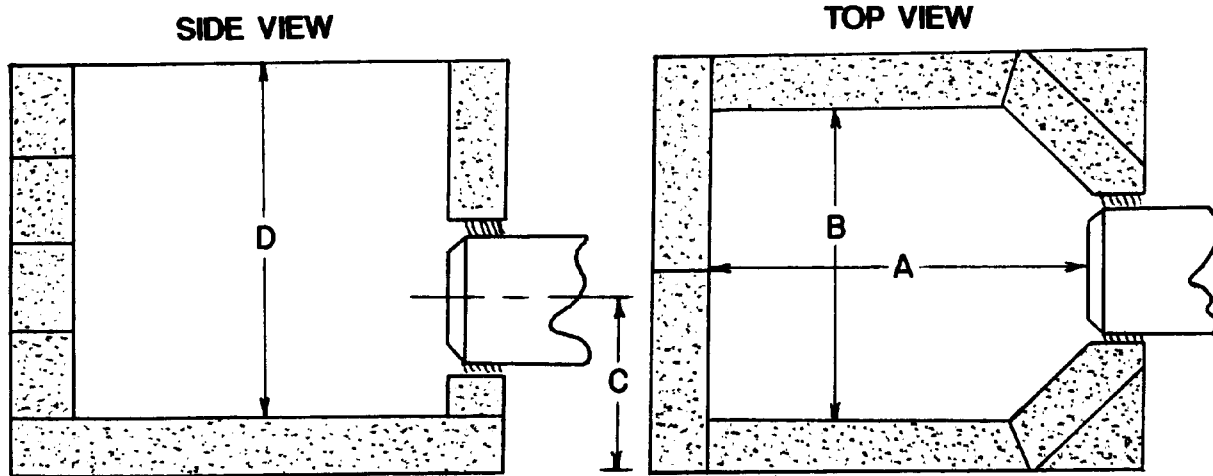

Figure 6-11. Square firepot.

(b) Pack around the blast tube to close the gap between the refractory and the burner blast tube. This prevents the flame from licking back on the blast tube and eventually burning it off. Leave a groove at the bottom of the packing so that oil dripping from the blast tube can drain into the firepot.

(c) Secure the burner to the floor with lag screws unless some other provision has been made in the furnace unit for locking the burner in place.

(2) *Installing constant ignition controls.*

(a) Select the appropriate wiring diagram from figures 6-12 and 6-13, depending on the air distribution system type (gravity or forced air). These diagrams are for constant ignition burners.

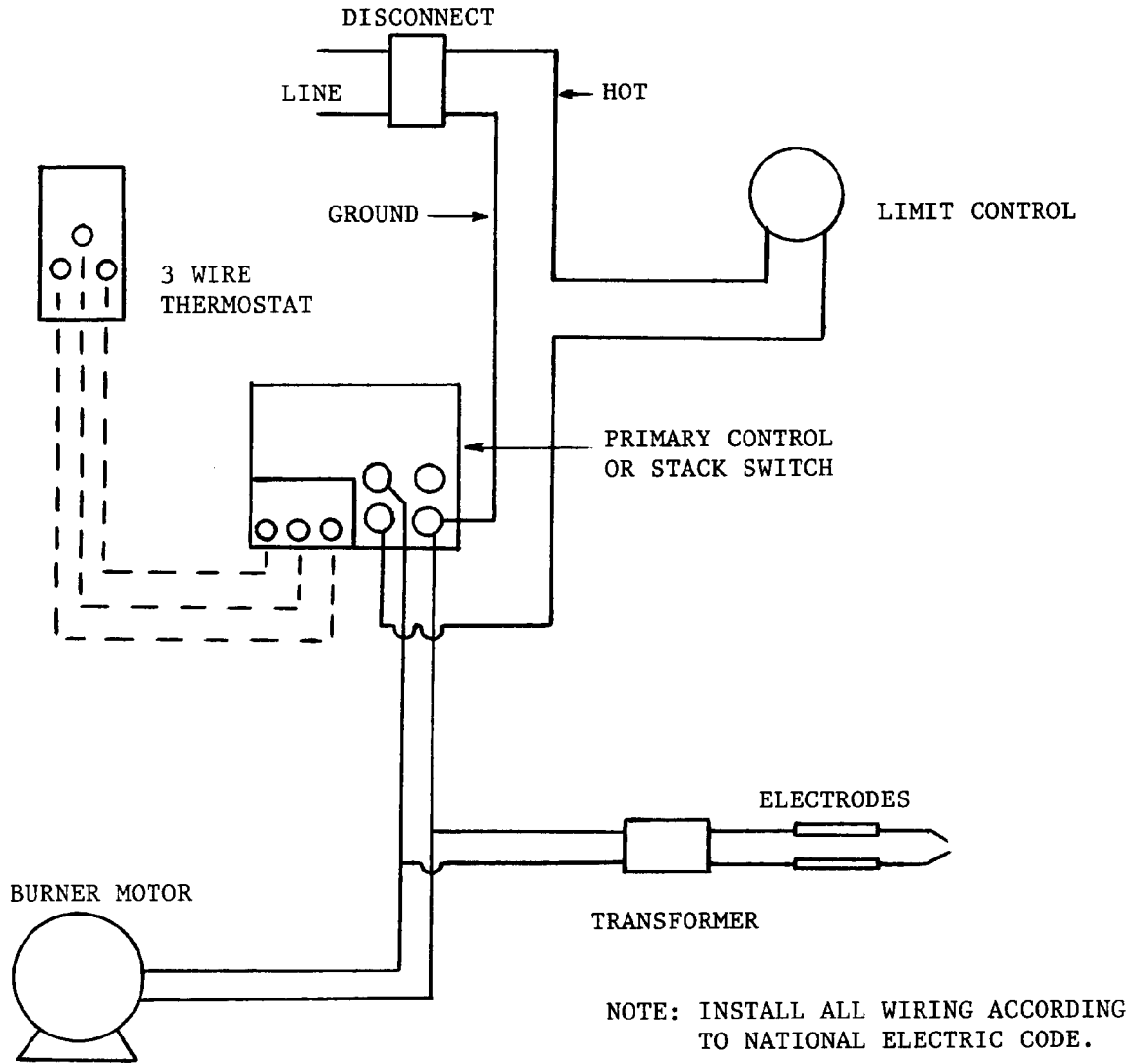

Figure 6-12. Wiring diagram, gravity furnace, constant ignition.



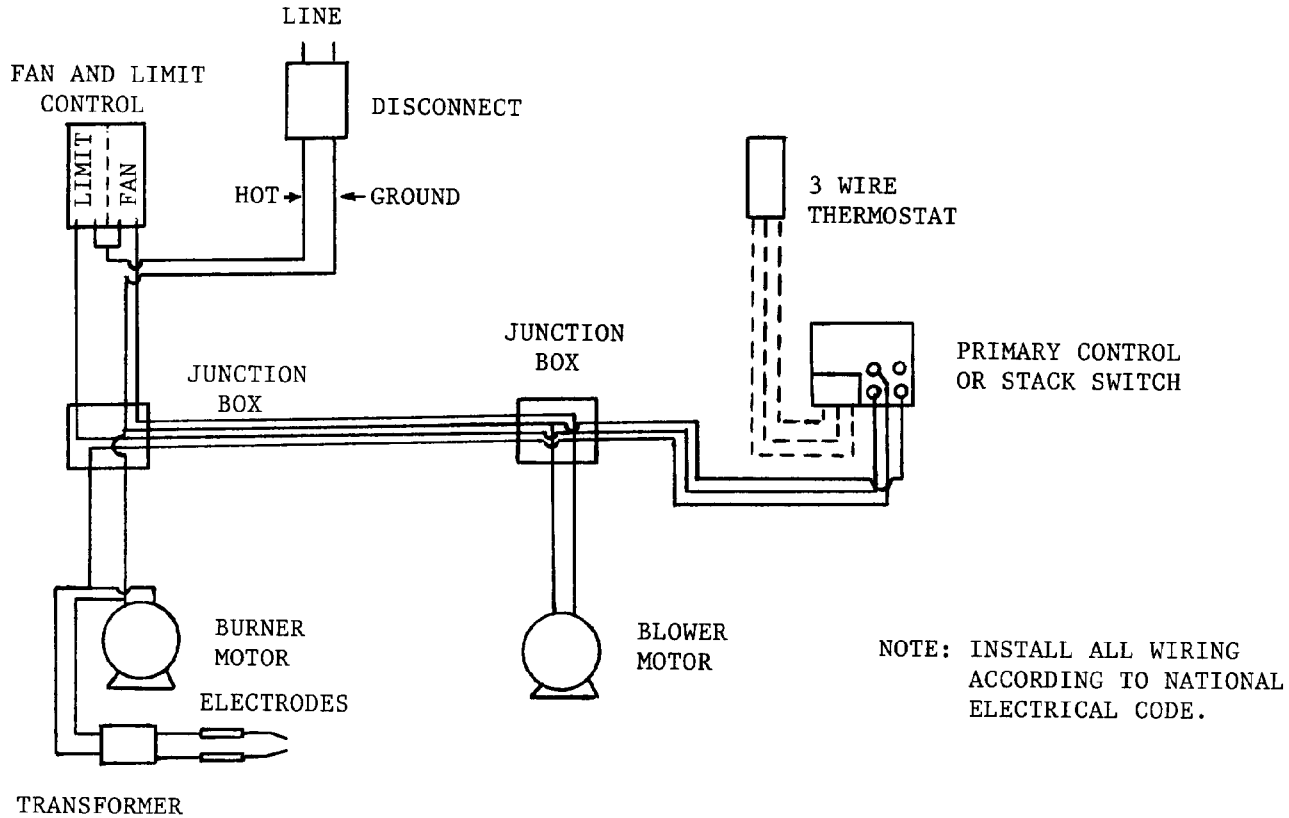

Figure 6-13. Wiring diagram, forced air furnace, constant ignition.

(b) Check the polarity of the wiring circuit carefully to ensure that “hot” and ground connections are as shown in the appropriate wiring diagram.

(c) Note that the burner motor and ignition transformer are wired in parallel; that is, one wire from each is connected to the “hot” line and the remaining wire from each is connected to the ground wire. If RF suppression (radio filter) is required, it should be wired in parallel with both the burner motor and ignition transformer.

(3) *Nozzle sizing.* Size the nozzle so that the furnace will provide enough heat to match the calculated heat loss of the building at design conditions. Oversizing results in lowered efficiency, fre-

quent burner cycling and temperature fluctuations within the building. In no case should the nozzle ever be sized larger than the input rating of the furnace. Assuming a furnace efficiency of 70 percent, the nozzle can be sized as follows:

$$\text{Nozzle Rate, GPH} = (\text{BTUH Heat Loss}) / (138,200 \times .70)$$

(4) *Nozzle selection.* Choose nozzles used in small units carefully. If a new unit using a new nozzle does not produce a perfect fire, try several other nozzles with the same markings. Trouble can occur even with new nozzles despite care used in its selection. For this reason, keep several spare nozzles in stock.

#### Section IV. GAS FIRED WARM AIR FURNACES

##### 6-14. General.

Gas fired warm air furnaces may be of the central type with the blower mounted on the same level as the combustion chamber (figure 6-14), the elevated

or “Hi-Boy” type with the combustion chamber above the blower (figure 6-15), or they may be of the duct or horizontal radiator type (figure 6-16).

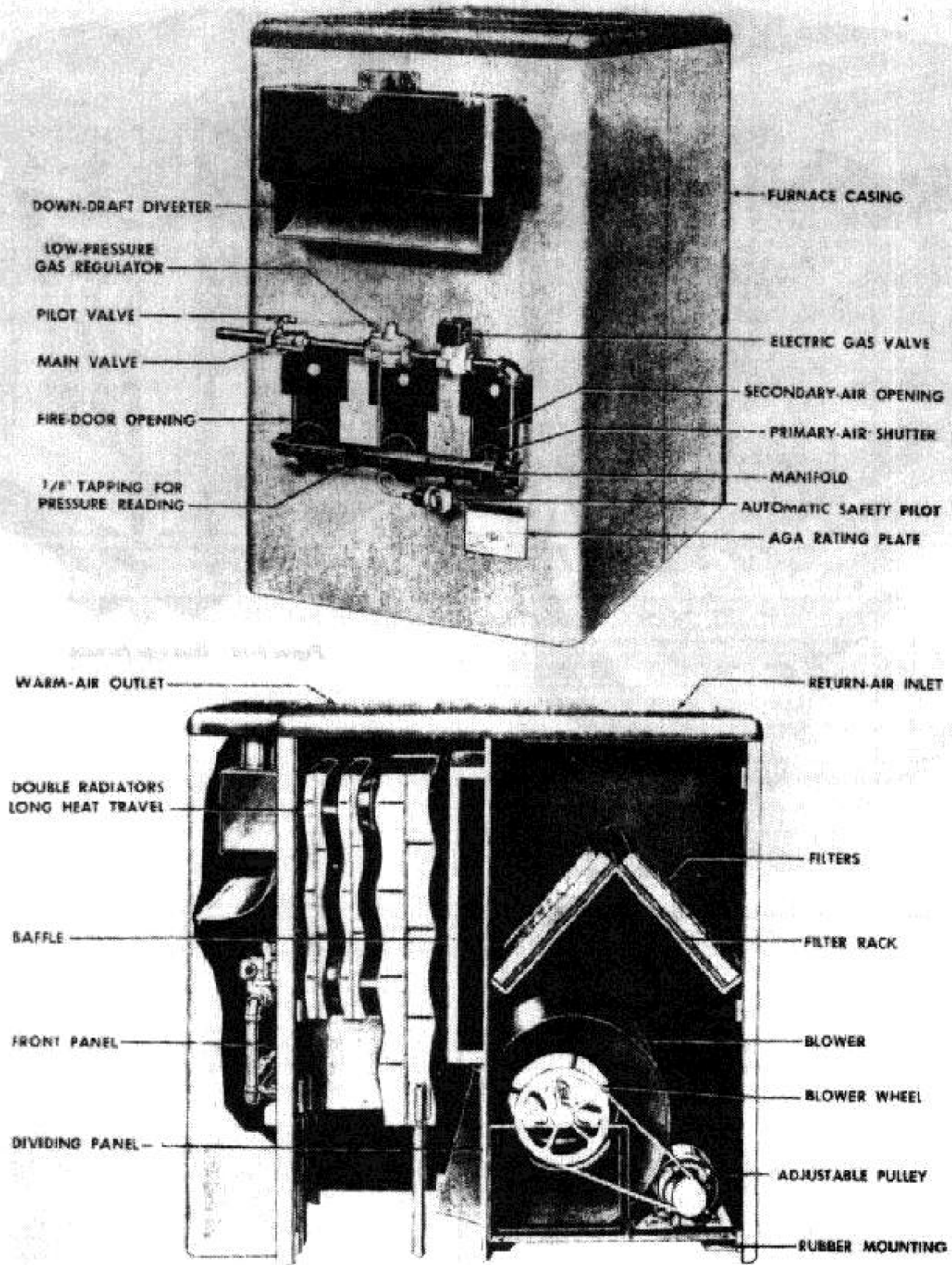
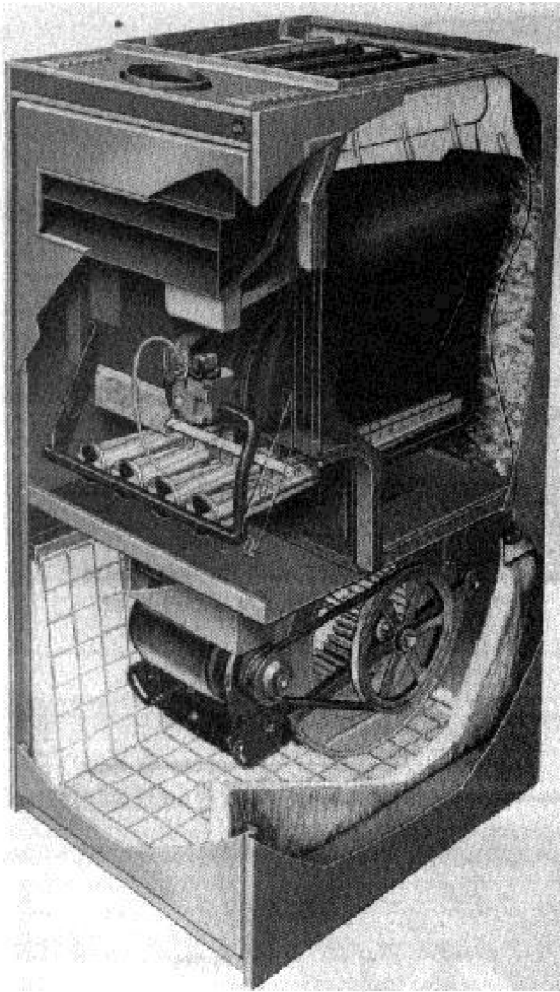
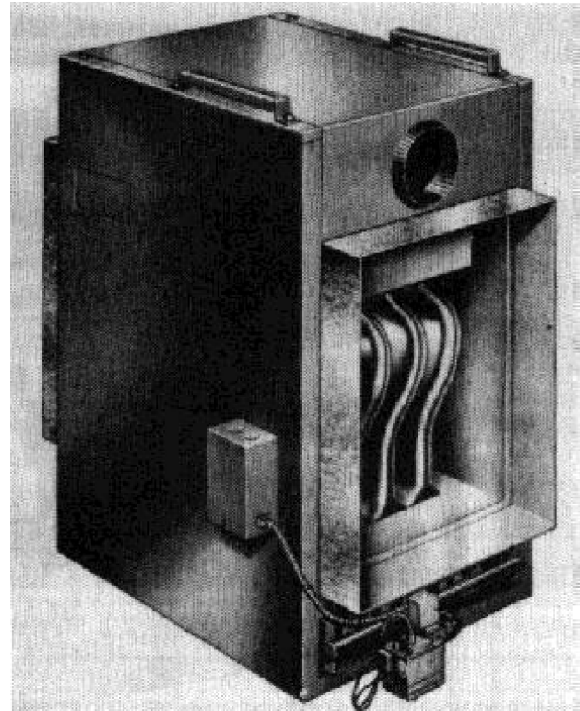

Figure 6-14. Gas fired central furnace.



*Figure 6-15. Gas fired elevated upflow furnace.*



*Figure 6-16. Duct type furnace.*

### 6-15. Construction.

Gas fired warm air furnaces are made of cast iron or steel. They are usually constructed with one or more radiators or special radiating surfaces to obtain maximum efficiency. They may be used in either gravity or forced air installations.

### 6-16. Furnace rating.

Always set the gas input rate consistent with the manufacturer's input rating; never exceed this rating. Heat delivery at the bonnet drops approximately 5 percent for each 1000 feet of elevation above sea level. Thus, if a furnace has a rating of 100,000 BTUH output at sea level, it will deliver only 75,000 BTUH at an elevation of 5000 feet above sea level. Furnaces must be sized consistent with this rule when they are intended for use at higher elevations.

### 6-17. Central furnaces.

Central furnaces may be supplied with the controls and downdraft diverter exposed, or one or both of these may be enclosed in a single cabinet if appearance is a factor. Likewise, the blower may be installed as a separate item, attached to the furnace by a "blower-boot" located between the furnace and the blower cabinet.

### 6-18. Vertical furnaces (Hi-Boy type).

This is the predominate type of gas furnace found at Army installations. Operation of the elevated unit or "High-Boy" is identical to that of the central unit.

*a. Upflow vertical furnaces.* Return air enters the unit through the return air duct located at the bottom or side of the unit and is drawn into and forced through the blower; it is then guided by baffles around and through the heat exchanger and discharged through the top.

*b. Down flow vertical furnaces.* The return air inlet is located at the top or upper side of the unit.

Air is directed through the blower and heat exchanger and is discharged at the bottom of the unit. These type units are typically used in underfloor air distribution systems. Figure 6-17 shows a typical downflow furnace.

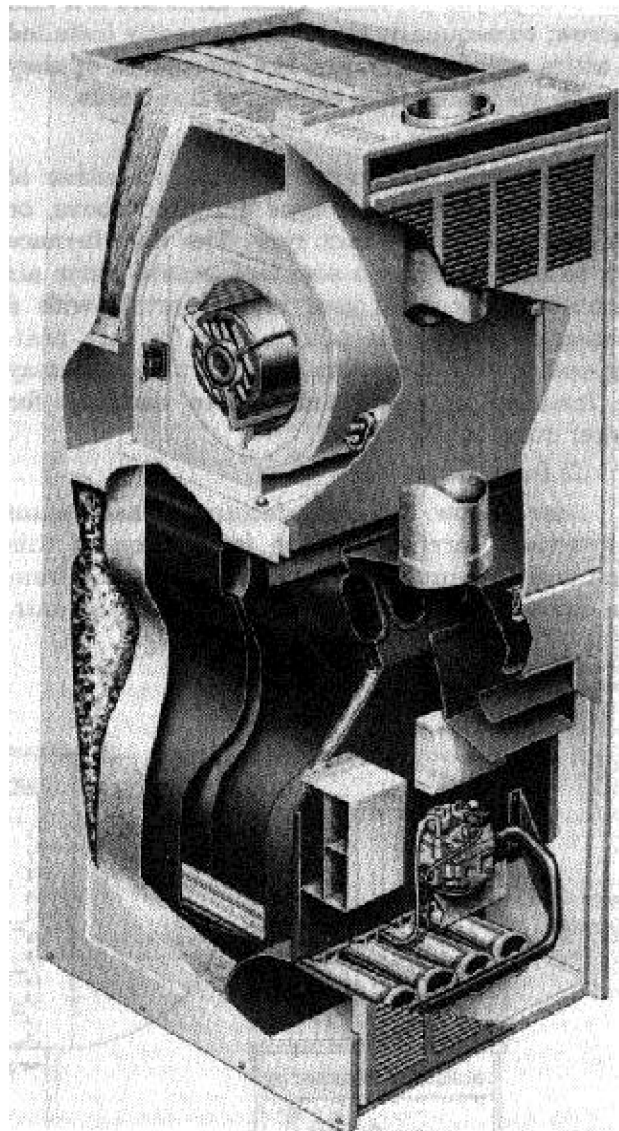

Figure 6-17. Gas fired elevated downflow furnace.

**6-19. Horizontal furnaces.**

In a horizontal furnace, the blower, filters, and heat exchangers are aligned horizontally with respect to each other.

*a. Low profile furnaces.* These units are low and narrow; consequently they are frequently installed in attics, crawl spaces, and low basements, or they may be suspended from ceilings or floor joists.

*b. Duct furnaces.*

(1) *General.* Horizontal furnaces are either of the low profile compact type described above, or they may be of the duct type. The duct furnace can be used as either a standard central warm air furnace or it can be used in conjunction with a cooling coil, using the same blower for both heating and cooling operations. The duct furnace may be installed in single units or in batteries for larger outputs.

(2) *Installation.*

(a) Follow the manufacturer's installation instructions carefully in the installation of this type unit. Air must always enter the casing from the direction of the baffles located within the unit.

Baffles are precisely located by the manufacturer to properly distribute air over the heating elements; do not attempt to adjust them. Failure to properly install these baffles usually results in failure of the unit after one or two seasons of operation.

(b) Exercise care to install the unit so that air flow is in the direction recommended by the manufacturer. Failure to do this may result in a burned out unit and/or unsatisfactory operation.

(c) If the blower and blower casing are not supplied by the furnace manufacturer, they must be installed with the blower outlet on an even plane with the radiators or combustion section of the unit, so that the air will pass through the unit in a horizontal stream (figure 6-18). Carefully monitor the gas input to avoid overfiring, which will result in damage to the radiators or combustion chamber. The control assembly is the same as that used on standard gas furnaces.

(d) In multiple furnace arrangements, each furnace must have its own downdraft diverter; vents should be joined by Y-fittings, never by T-fittings.

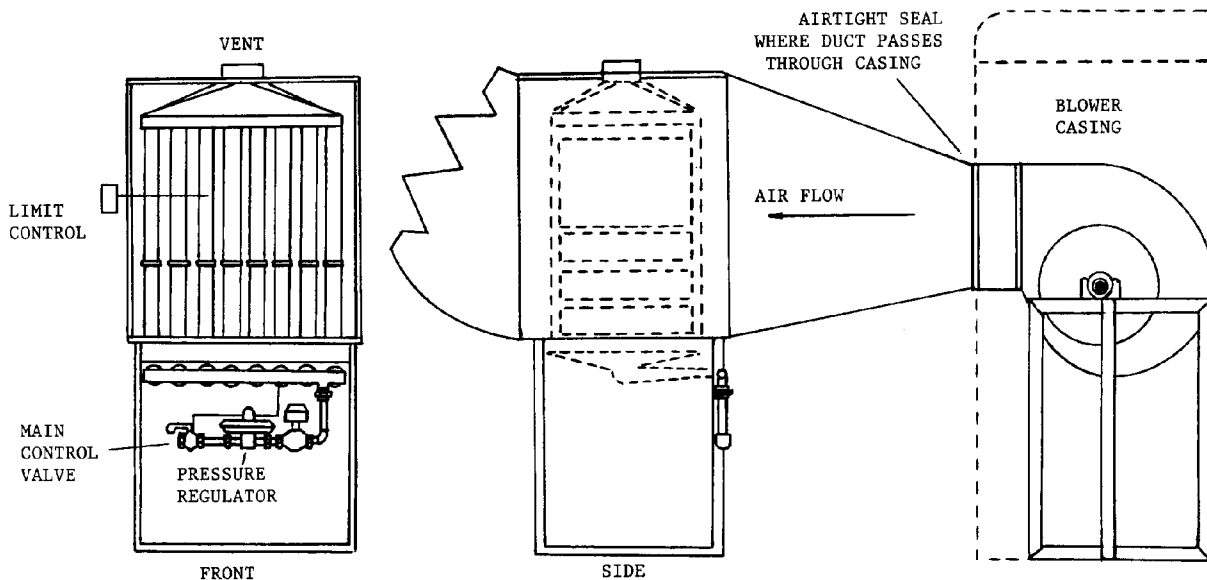

Figure 6-18. Installation of a typical duct furnace.

(3) *Air delivery.* The maximum and minimum air deliveries for which these furnaces are designed are shown on the nameplate or in the manufacturer's literature. In no case should air be delivered above or below those ratings. Too low an air flow rate will result in excessive temperatures, while too high a delivery may result in condensation

within the unit. Both conditions will shorten the life of the unit.

(4) *Use with refrigeration system.* Never install a duct furnace downstream from a refrigeration coil, because the cold air will cool down the heating elements, causing reverse circulation of moisture-laden air down the vent through the inside of the heating element. This will result in rust scale,

shortening the life of the unit as well as closing flue passages and impairing combustion. It is also unsatisfactory to install a duct furnace upstream from the cooling coil, as the cooling coil may be damaged or the refrigerant decomposed during the heating season. When both heating and cooling coils are used in the same system, install the coils in parallel (figure 6-19) using a damper downstream of the furnace to change over from the heating to the cooling cycle. If more air is required for ventilation than is permitted by the manufacturer, the additional air must bypass the furnace through a duct around it. This bypass must be equipped with a volume control damper, properly adjusted to maintain the appropriate air flow through the furnace. Occasionally, bypass ducts are used to obtain larger volumes of air for summer ventilation than for winter heating. In such cases, the installation must be equipped with interlocking control to prevent the furnace from operating unless dampers are set for proper air delivery through the furnace.

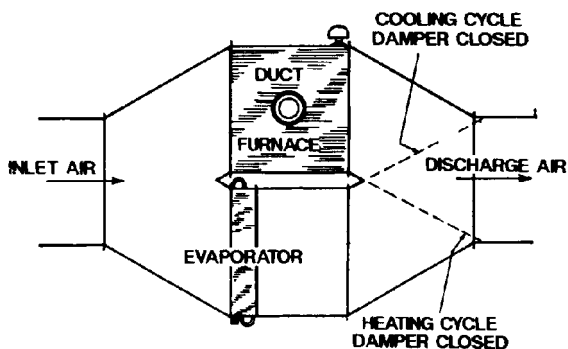

Figure 6-19. Damper arrangement for duct furnace and cooling coil.

## 6-20. Gas conversion furnaces.

In certain instances, coal furnaces may be modified for gas burning capability through the installation of gas conversion burners. Before installing a gas conversion burner in a coal furnace, carefully study the existing heating system to assure that: the furnace and heating system are in good operating condition; the furnace has sufficient capacity to heat the building properly and; the fire-box or combustion chamber must be large enough for the conversion burner. Normally, gas conversion burners are not recommended for warm air furnaces or small boilers because of the cost of operation; it is usually more economical to replace a coal burning furnace with a unit specifically designed for gas fired operation.

*a. Gas conversion burner.* A leaning refractory type of burner is considered most satisfactory for

the average small coal fired furnace because hot gases are directed along and against the radiating surface, which is limited. In this type burner, baffles are supported at one end by a support on the inner side of the burner and at the other end by a retaining ring. Gas combustion occurs below the leaning baffle. Most leaning baffle type burners have a draft door which will open to a predetermined point while the burner is in operation and will close when the gas is shut off. Open the draft doors just enough to admit the proper amount of primary and secondary air (determine the amount of air admitted at this point by the appearance of the gas flame or by the use of a combustion analyzer).

*b. Gas conversion burner installation.* If the furnace smokepipe outlet is less than 18 inches above the grate level, there is usually insufficient draft for proper operation of the burner. Gas conversion burners operate at low efficiency with high fuel consumption in all types of furnaces which do not have a radiator or secondary heating surface. This type of furnace is unsuitable for efficient operation of a gas conversion burner. Inspect and test for leaks to insure that no products of combustion escape into the heated air delivered to the building.

(1) *Burner capacity.* In determining conversion burner size (BTUH input), not more than 70% efficiency should be assumed and frequently the efficiency obtained is less. In addition to the heating load of the building, the BTUH input must be great enough to allow for this low efficiency plus pipe loss and an additional 25 percent for the starting load.

(2) *Controls.* Controls used on gas conversion burners should be of the same type as controls recommended for gas designed furnaces. Never install so-called "homemade burners"; never install a burner in the firing door.

(3) *Flue pipe/vent.* Complete heating plants designed for gas fired furnaces and unit heaters are constructed with a flue outlet of proper construction and proper draft (downdraft diverter). A damper is therefore not required in the vent pipe. Gas conversion burners installed in coal furnaces which have a flue outlet designed for coal burning operation need a damper in the flue pipe to reduce the draft to a proper value. Provide a check damper or similar opening in the flue pipe and an adjustable pipe damper between the check damper and the furnace for "fine-tuning" of the draft.

(4) *Draft hood.* A draft hood may be used in place of the check damper. Even with its use, however, in most cases it is impossible to establish the draft through the furnace accurately by the use of a

draft hood alone. For this reason, the pipe damper is still required. In the absence of a regular canopy or hood type downdraft diverter, a satisfactory type of draft hood can be fabricated as shown in figure 6-20.

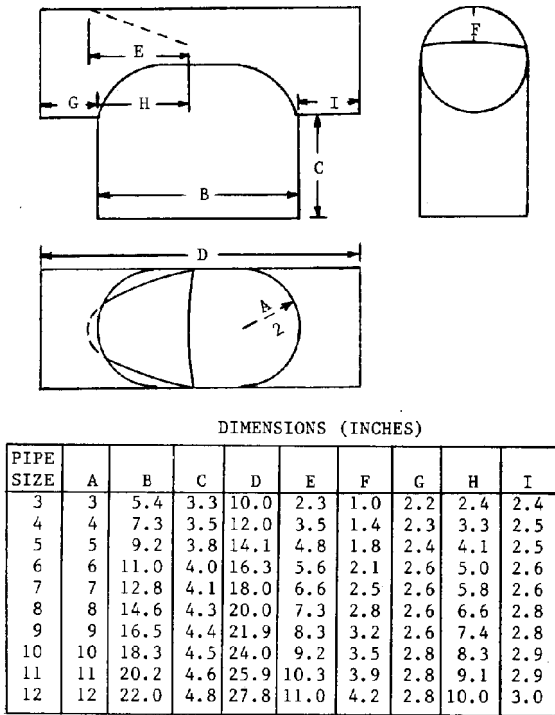
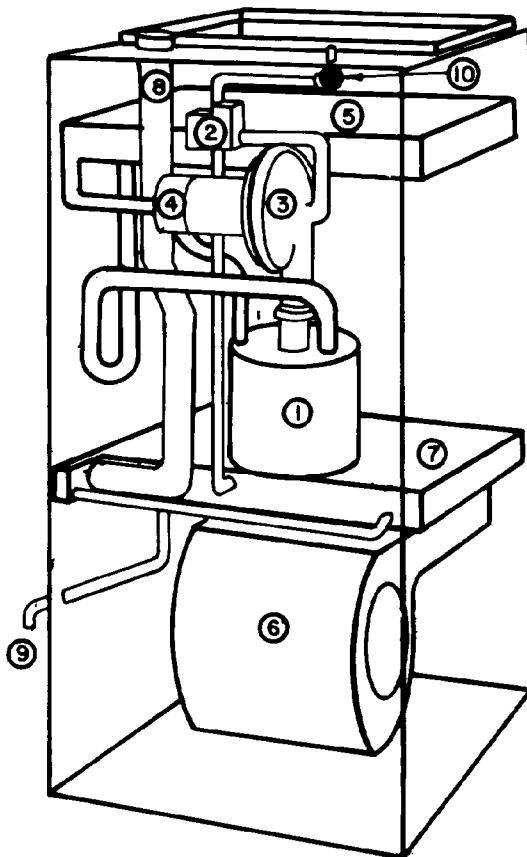

Figure 6-20. Draft hood.

**6-21. Fully condensing furnaces.**

The term “fully condensing” refers to the fact that the flue gas from these furnaces passes through a heat exchanger coil in the air stream (upstream of the heating section), substantially cooling and condensing the products of combustion. This is essentially a flue gas heat reclaim system packaged within the furnace, yielding a very efficient heating system. Efficiencies of 90 to 95 percent are commonly reported. Instead of discharging flue gas at temperatures greater than 400F, as is common with gas fired furnaces, these units discharge condensate to a suitable drain and low temperature exhaust gas through a plastic vent pipe. Because the condensate contains combustion byproducts, it is mildly acidic. Some condensing furnaces open a water valve at the end of each heating cycle, which flushes the coil and carries away any remaining condensate (figure 6-21). Operating procedures vary depending on the manufacturer, but for the most part, fully condensing furnaces are operated similar to conventional furnaces.



- |                                |                        |
|--------------------------------|------------------------|
| 1. HEAT TRANSFER MODULE.       | 6. BLOWER.             |
| 2. NEGATIVE PRESSURE GAS VALVE | 7. RECUPERATIVE COIL . |
| 3. COMBUSTION AIR BLOWER       | 8. EXHAUST PIPE        |
| 4. SOLUTION PUMP               | 9. CONDENSATE DRAIN    |
| 5. HEATING COIL                | 10 WATER VALVE         |

Figure 6-21. Typical fully condensing furnace.

### 6-22. Fully condensing furnace maintenance.

Disconnect electrical power before servicing. Check the furnace at least once every year, before the heating season begins, to be sure that there is adequate combustion air and that the vent system is working properly. Check the vent pipe to be sure it is not blocked.

#### a. Combustion air.

(1) Normally the air for combustion and ventilation for a furnace can be obtained from the basement area.

(2) If a furnace is installed in a closet and the closet door is louvered, do not obstruct louvers.

Louvers must be open and clear to provide combustion air to the furnace.

(3) If the furnace is installed in a confined space within a building and the air for combustion enters the space through ducts from the outside, be sure to check the entering and outlet (grilled) openings so that they are always clear and clean.

b. *Blower motor lubrication.* Always relubricate the motor according to the manufacturer's lubrication instructions on each motor. Some blower motors are permanently lubricated and do not require any further oiling.

c. *Filters.* The filter in the furnace is designed for high velocity heating and cooling applications.



Filters of the washable type may be washed and dried. Spray the filter media with a dust adhesive as per instructions on the adhesive spray container. Filters should be inspected and cleaned every two months or as required.

(1) Remove the filter per manufacturer's instructions.

(2) Use a vacuum cleaner to clean out the blower area and the adjacent area of the return air duct.

(3) Clean, wash and dry the permanent filter, then spray both sides with a dust adhesive as recommended on the adhesive container. Re-install the filter. Be sure the arrow on the filter points in the direction of the air flow.

d. *Check heating solution.* For those furnaces using a liquid heating solution, check this during the annual inspection. Observe the solution level in the plastic expansion tank. Remove the top door on the front of the furnace and observe the solution level. It should be between the two straps which secure the plastic tank. Refer to the label on the tank. If it is necessary to add solution because of evaporation losses or minute leaks, refer to manufacturer's instructions.

e. *Operating difficulties.* If the furnace fails to operate, it is possible the safety pressure switch is open. This switch is used on some furnaces to shut down the system if the condensate line or flue is blocked. The combustion blower will continue to run until the blockage in the flue pipe or condensate discharge line is clear. Do not discharge condensate to the outside if there is a possibility of freezing. To avoid blockage in the condensate line, condensate should discharge into an open drain and the tubing should be protected so that it cannot be crushed or flattened out.

**6-23. Pulse combustion furnaces.**

These furnaces are also "fully condensing" but obtain higher efficiency by means of the pulse combustion principle. These units do not require a pilot burner, main burners, conventional flue or chimney. Initially the combustion takes place in a chamber; then, as combustion products pass through the heat exchanger system into a coil, the latent heat of combustion is extracted, condensing water from the exhaust gas. Electronic spark ignition is used to initiate combustion. A schematic representation and sequence of operation are presented in figure 6-22. Pulsed combustion furnaces have efficiencies as high as 95 percent and, as with the fully-condensing furnaces discussed previously, discharge flue gases at 100F-120F through a plastic

(typically PVC) pipe. These furnaces can be vented through a side wall, roof, or to the top of an existing chimney.

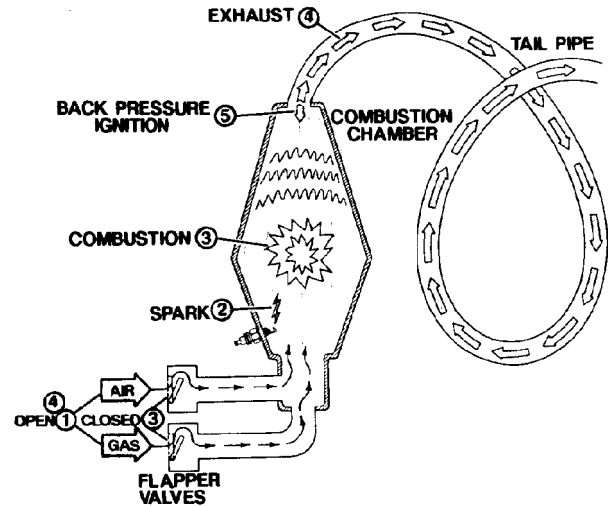

Figure 6-22. Pulse combustion process.

a. *Operation.*

(1) With thermostat set below room temperature and power to the furnace off, turn manual knob of the gas valve clockwise to the "OFF" position. Wait 5 minutes.

(2) Turn manual knob of gas valve counter-clockwise to the "ON" position. Turn power on and set pre-purge for 30 seconds and then ignite.

(3) If the unit does not light on the first attempt, it will attempt up to four more ignitions before locking out.

(4) If lockout occurs, turn thermostat off and then on again.

b. *Manual shutoff*

(1) Set thermostat to its lowest temperature and disconnect furnace power supply.

(2) Turn manual knob of gas valve to "OFF" position.

**6-24. Pulse combustion furnace maintenance.**

At the beginning of each heating season, check the furnace as follows:

a. *Blower.*

(1) Check and clean blower wheel.

(2) Lubricate motor according to the manufacturer's instructions. If no instructions are provided, use the following as a guide:

(a) *Motors without oiling ports.* These motors are prelubricated and sealed. No further lubrication required.

(b) *Direct drive motors with oiling points.* These motors are prelubricated for an extended period of operation. For extended bearing life, re-

lubricate with a few drops of SAE No. 10 nondetergent oil once every two years. It may be necessary to remove blower assembly for access to oiling ports.

*b. Filters.*

(1) Filters must be cleaned or replaced when dirty to assure proper furnace operation.

(2) The washable foam filters supplied with some furnaces can be washed with warm water, dried and sprayed with an adhesive according to the manufacturer's recommendations.

*c. Fan and limit control.* Check fan and limit controls for proper operation and setting. For settings, refer to manufacturer's setting instructions on each fan.

*d. Electrical.*

(1) Check all wiring for loose connections.

(2) Check for correct voltage at unit (unit operating).

(3) Check amp draw on blower motor.

*e. Intake and exhaust lines.* Check plastic intake and exhaust lines and all connections for tightness and make sure there is no blockage. Also check condensate line for free flow during operation.

*f. Heat exchangers and burners.* Clean with vacuum and/or brush.

## 6-25. Automatic vent dampers.

The typical building is heated by an oil or gas fired central furnace or boiler. During periods when the indoor temperature drops below the thermostat setting, the heater cycles on and off several times each hour as is required to replace heat lost from the building. Gas furnaces of American Gas Association (AGA) certified design have measured laboratory and field efficiencies of 75 percent at full load steady state operation. During furnace operation, stack energy losses amount to 25 percent of the heating value of the fuel. While the furnace is not operating between heating cycles, natural flue draft will cause air supplied to the furnace to go up the stack. Furnaces which draw combustion and stack dilution air from a heated space require up to 10 percent more fuel to heat the makeup air. The purpose of an automatic vent damper (AVD) is to reduce the losses of this heated air when the furnace is not in operation. No savings are gained while the burner is operating except to the extent that an AVD reduces natural draft when it is open. AVD dampers are classified as to their location and by the type of power used to operate them. A flue damper is one which is installed upstream from the point where dilution air enters

the stack. A vent damper is installed downstream of the place where dilution air enters on gas furnaces and downstream of the barometric damper on an oil furnace. Most AVD's on the market today are designed for use as their name implies, in the vent downstream of the draft hood.

*a. Thermal dampers.* Thermal dampers use hot flue gas to activate their closure mechanism. When the furnace burner is not in operation, bimetallic louvers in a thermal damper close. The design of the louvers when closed offers approximately 10 percent open area, allowing some draft for the pilot light. When the burner is on, the bimetallic louvers bend back toward the walls of the vent providing more draft as the hot combustion products rise in the stack and cause the damper to open. Thermal dampers should only be considered in application to gas burning appliances as oil burners result in temperatures which are excessive. The major advantages of thermal dampers are their relative low cost, simplicity of installation, and ability to operate without need for electrical circuitry.

*b. Electrical dampers.* Electrically operated vent dampers are available for use with gas and oil burners. Various types of actuation mechanisms are available. In some designs, an electrical motor is used to rotate a metal plate in the flue. In other designs, a lever rotates the shaft which is actuated by a solenoid. All designs of electrical dampers incorporate limit switches which prevent the dampers from closing when the burner is still on. In addition, some designs have a fail safe mechanism that opens the damper in the event of a power failure. Electrical vent dampers have an advantage over thermal dampers in that they are directly controlled by the on/off action of the burner. Closure of the damper is rapid following the burning cycle thereby maximizing the energy savings. Electric dampers do require an external power source and since they are electro-mechanical in nature, are subject to failure of components.

*c. Mechanical dampers.* Mechanical dampers use a form of mechanical energy to actuate closure of the device. Most such devices are of the gas pressure type. This type is operated by the gas pressure which passes the thermostat controlled main gas valve activating a lever mechanism that opens the damper. A diaphragm actuated valve is used in a return line to the burner to control the gas to the burner. Mechanical dampers have the advantage of not requiring electrical controls. It does require a more complex installation and can, therefore, cost more than other types of dampers.

**Section V. GAS FIRED UNIT HEATERS**

**6-26. General.**

Unit heaters are located directly in the space to be heated and basically consist of a radiator and a fan. They differ from fancoil units in that they are generally suspended from the ceiling instead of being placed under windows and they can be direct fired. Certain types, such as steam unit heaters, are supplied with heat from a central heating plant; others, such as gas fired unit heaters, generate the heat within the unit itself. This section covers only gas fired ceiling-suspended units.

**6-27. Description.**

Gas fired unit heaters (figure 6-23) usually consist of a combustion chamber with atmospheric type gas burners mounted in the bottom. Combustion air enters the combustion chamber through openings in

the bottom. A number of radiators or tubes, which act as heat exchangers, extend from the top of the combustion chamber. Across the top of the radiator section is a chamber for collecting the products of combustion and conducting them to a down draft diverter and vent. A propeller type fan, mounted behind the radiator section, forces air through the radiator, heating the air. The fan is usually mounted to the shaft of an electric motor (direct drive), turning at motor speed. Belt driven fans turning at lower speeds are also used. Certain types of unit heaters use a centrifugal blower when higher air velocities are required or when the air must be moved through a duct. The air outlet of a gas fired unit heater usually contains louvers to direct the air stream.

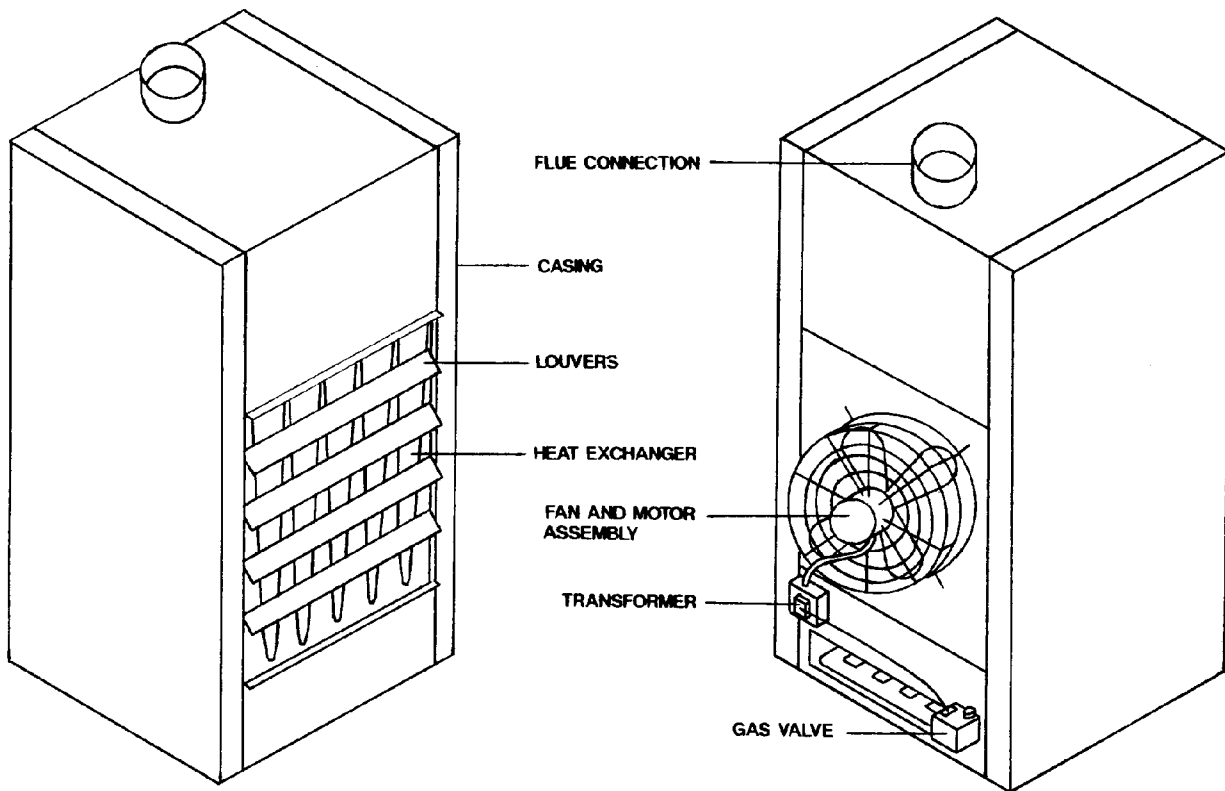

Figure 6-23. Gas fired unit heater.

**6-28. Operation.**

Gas fired unit heaters have a safety pilot and automatic valve and a suitable control for opening the gas valve only after the fan or blower has started. The operating cycle of the automatic control equipment is as follows:

- a. The thermostat makes its electrical contacts, starting the fan or blower, which opens the gas valve, permitting gas to flow to the burner, where it is ignited by the safety pilot.
- b. When the space temperature has been raised to a preselected point, the thermostat breaks its

electrical contacts, which closes the automatic valve as the speed of the fan (or blower) decreases.

**6-29. Installation.**

a. Consider the effective length of the heat zone when selecting and locating equipment. Figure 6-24 provides a correlation between the effective length of the heat zone versus discharge air velocity at the

unit heater outlet. If the building walls between which the air stream is projected are less than 20 feet apart, the effective length of the heat zone may be lengthened accordingly. The amount of allowable increase depends entirely upon local conditions. With a centrifugal blower, a "throw" of about 50 to 70 feet may be obtained.

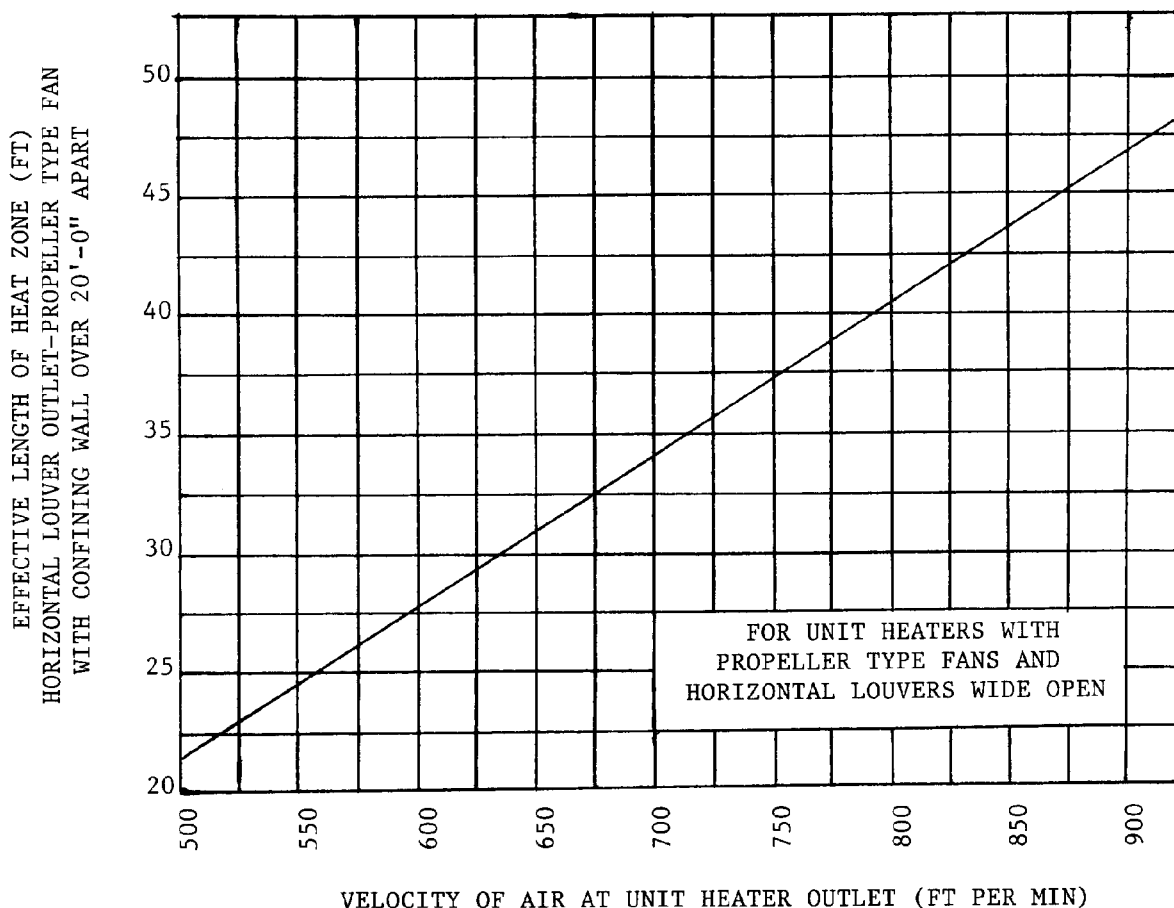

Figure 6-24. Unit heater heat zone length.

b. The ideal position of the unit heater is with the bottom located from 8 to 10 feet above the floor (figure 6-25). If it should be necessary to locate the heaters further above the floor, using a nozzle which points toward the floor helps to obtain a higher velocity. DO NOT INSTALL A

UNIT HEATER LESS THAN 18 INCHES FROM A WALL. DO NOT ATTACH COMBUSTIBLE MATERIALS TO HEATERS. Mount the heater in such a fashion that the stream of heated air sweeps the cold walls (unless heat in a specific area is required).

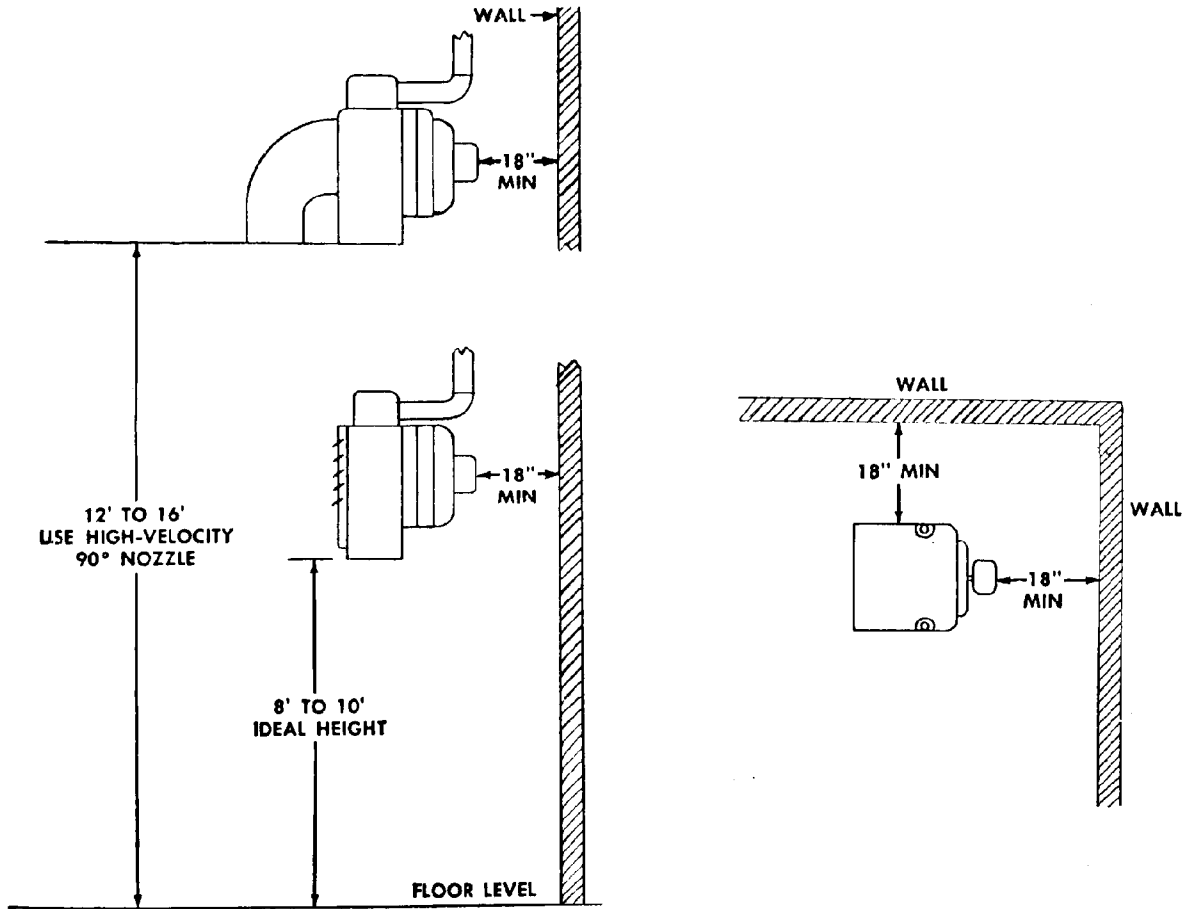

Figure 6-25. Typical unit heater installation.

## Section. VI. INFRARED HEATERS

### 6-30. Gas fired infrared heaters.

Although infrared energy can be produced by burning gas as an open flame, modern gas fired infrared heaters use burning gas to heat a specific radiating surface because heated surfaces tend to be better radiators than open flames. The surfaces are heated by direct flame contact or with combustion gases. Heaters are currently available in four basic types, as follows:

*a. Indirect type.* Indirect infrared heaters are shown in figure 6-26(a and b). They are indirect in that they are internally fired and have the radiating surface between the hot gases and load. Combustion takes place within the radiating elements, which may be ceramic or metallic, tubes or panels, and which operate with surface temperatures up to 1200 deg F. These units are generally vented and may require deductors (fans), as is the case for the type shown in figure 6-26(b).

*b. Porous refractory type.* A porous refractory infrared heater is shown in figure 6-26(c). A refrac-

tory material is the main element of this type of burner. A combustible gas air mixture enters the enclosure and flows through the refractory material to the exposed face. Combustion occurs quite evenly on the exposed surface, heating it to produce radiant energy to add to that from the flame. Resulting surface temperatures approach 1650F.

*c. Direct fired refractory type.* A direct fired refractory infrared heater is shown in figure 6-26(d). Impingement of hot gases or flame on an open refractory surface produces the infrared energy emitted by these units. The temperature of the radiating surface ranges from 1650F to 2800F.

*d. Catalytic oxidation type.* A catalytic oxidation infrared heater is shown in figure 6-26(e). This type heater is somewhat similar to the porous refractory heater in construction, appearance, and operation, but the refractory material is usually glass wool and the radiating surface is a catalyst that causes oxidation to proceed without visible flames.

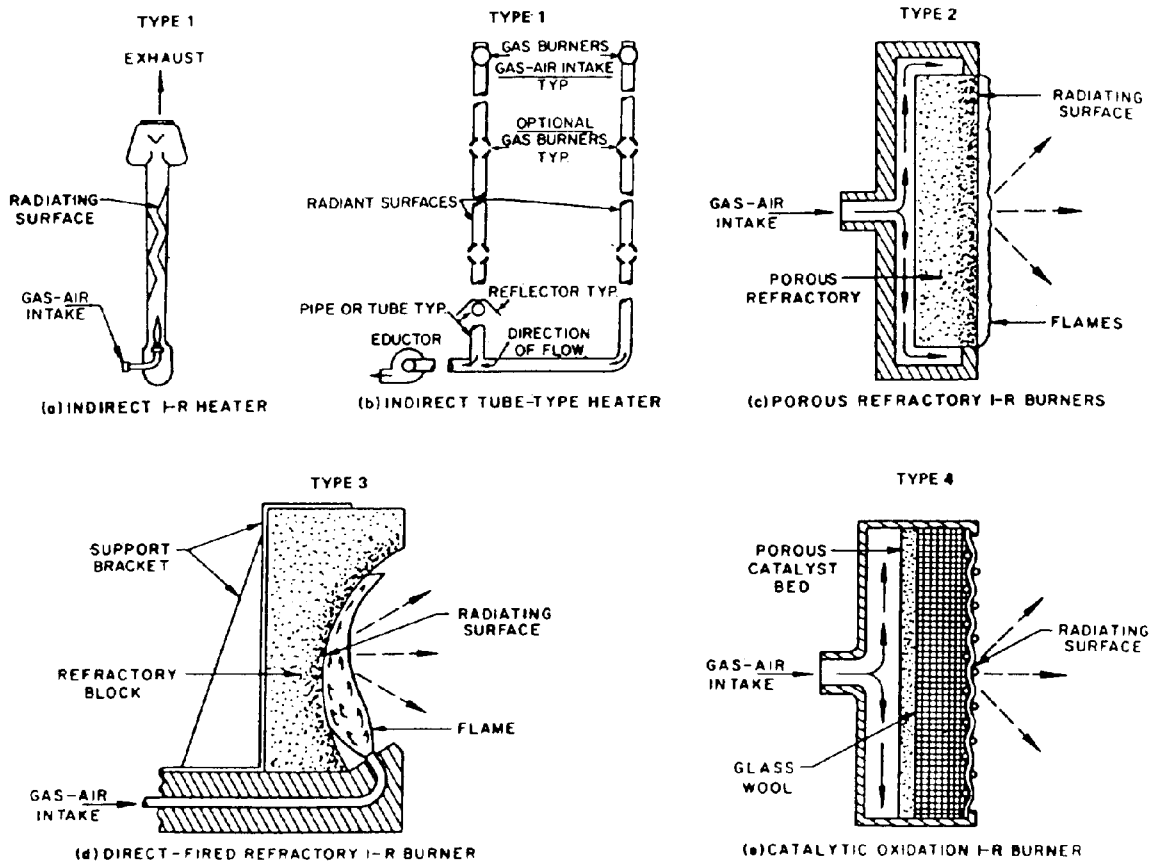

Figure 6-26. Gas fired infrared burners.

### 6-31. Electric infrared heaters.

Electric infrared heaters use heat produced by current flowing in a high resistance wire or ribbon. There is a wide variety of types; the main difference between them is the way the wire or ribbon is supported and the way the heat is transferred. The following four types are most commonly used:

*a. Metal sheath element.* The metal sheath element electric infrared heater is shown in figure 6-27(a). The elements are composed of a nickel-chromium heating wire that is embedded in an electrical insulating refractory encased by a metal tube. These elements are the most rugged of the four

types and have excellent resistance to thermal shock, vibration, and impact. They can be mounted in any position. At full voltage, the elements attain a sheath surface temperature of from 1200F to 1800F. Higher temperature is obtained by configurations such as a hairpin shape. These units are generally used in a fixture that also contains a reflector which aids in directing radiation to the load. Higher efficiency is obtained if these elements are shielded from wind. When this protection is needed, it is usually provided for by the fixture design.

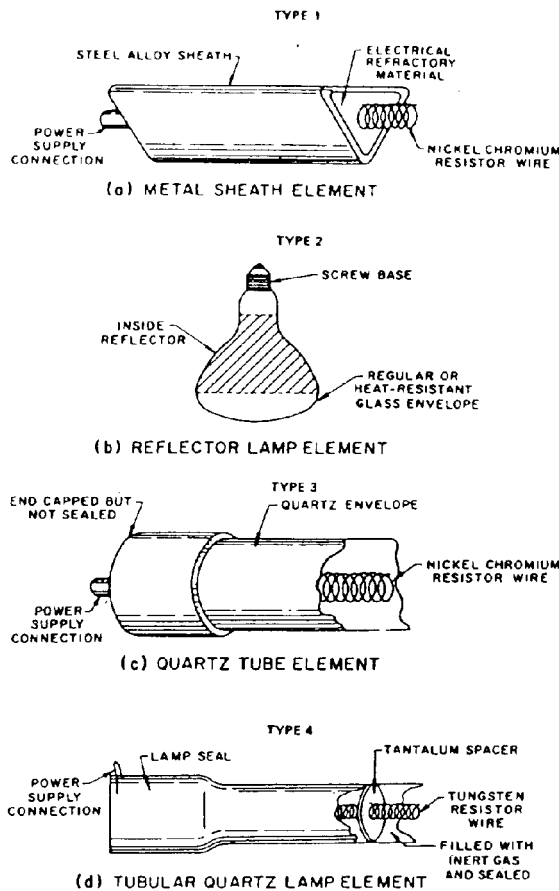

Figure 6-27. Electric infrared heating elements.

*b. Reflector lamp type.* A reflector lamp infrared heater is shown in figure 6-27(b). This type of heater has a coiled tungsten filament which approximates a point source radiator. The filament is enclosed in a heat-resistant, clear, frosted, or red glass envelope which is partially silvered inside to form an efficient reflector. Common units may be screwed into an ordinary 120 volt light socket.

*c. Quartz tube type.* A quartz tube infrared heater is shown in figure 6-27(c). This unit has a coiled nickel-chromium wire lying unsupported within an unevacuated fused quartz tube, which is capped (not sealed) by porcelain or metal terminal blocks. These units are easily damaged by impact and vibration, but stand up well to thermal shock and splashing. They must be mounted in a horizontal position to minimize problems of coil sag and are usually used in a fixture that also contains a reflector which aids in directing radiation to the load. Normal operating temperature ranges from

1300F to 1800F for the coil and about 1200F for the tube.

*d. Quartz lamp type.* A quartz lamp infrared heater is shown in figure 6-27(d). A typical unit consists of 0.38 inch diameter fused quartz tube containing an inert gas and a coiled tungsten filament that is held in a straight line and away from the tube by tantalum spaces. Filament ends are embedded in the envelope end sealing material. Quartz lamps must be mounted horizontally, or nearly so, in order to minimize filament sag and overheating of sealed ends. At normal design voltages, quartz lamp filaments operate at about 4050F and the envelope at about 110F.

### 6-32. Oil fired infrared heaters.

Oil fired infrared heaters are similar to gas fired indirect type units. Oil fired units are vented.

### 6-33. Precautions.

Observe the following precautions in the application of infrared heaters:

*a.* All infrared heaters discussed here have high surface temperatures when they are operating and, therefore, should not be used where the atmosphere contains ignitable dust, gases, or vapors in hazardous concentrations.

*b.* Manufacturer's recommendations for clearance between a fixture and combustible material should be followed. If storage of combustible material without adequate clearance between it and a fixture is likely or possible, warning notices defining proper clearances should be permanently posted near the fixture.

*c.* Manufacturer's recommendations for clearance between a fixture and personnel should be followed in order to prevent personnel stress from local overheating.

*d.* High intensity infrared fixtures should not be used if the atmosphere may contain gases, vapors, or dust that decompose to hazardous or toxic materials in the presence of high temperature and air. For example, infrared units should not be used in an area where there is a degreasing operation which uses trichloroethylene, which when heated, forms phosgene, a toxic compound, and hydrogen chloride, a corrosive compound.

*e.* Humidity control is necessary for areas with unvented gas fired infrared units because water formed by combustion will increase humidity. Sufficient ventilation, direct venting, or installation of insulation for cold surfaces are means that may be used.

*f.* When combustion type infrared heaters are used, adequate makeup air must be provided to re-

place the air used in combustion, regardless of whether or not units are direct vented.

g. If unvented combustion type infrared heaters are used, adequate ventilation must be provided to assure that products of combustion in the air in the space are held to an acceptable level.

h. Personnel who are to be maintained at a comfort level by use of infrared heating equipment should be protected from substantial wind or drafts. Usually, suitable wind shields that prevent windchill are more effective than increasing radiation to compensate for it.

#### **6-34. Maintenance.**

The manufacturer's recommendations should always be followed. Electric infrared systems require little care beyond keeping the reflectors clean. Quartz and glass elements must be handled

carefully because they are fragile, and fingerprints must be removed (preferably with alcohol) in order to prevent etching at operating temperature, which in turn will cause early failure. Gas fired and oil fired infrared heaters require periodic cleaning to remove dust, dirt, and soot. Reflecting surfaces, in particular, must be kept clean in order to be efficient. An annual cleaning of heat exchangers, radiating surfaces, burners, and reflectors should be performed with a cleaner that does not leave a film on aluminum surfaces. Both main and pilot air ports of gas fired units should be kept free of lint and dust. The nozzle draft tubes, and end cones of burners of oil fired units have been designed to operate in a particular combustion chamber and, when necessary, should always be replaced with an exact duplicate.

### **Section VII. OPERATING AND MAINTENANCE PROCEDURES**

#### **6-35. General.**

Most warm air systems at Army installations are of the forced air type; therefore, operating and maintenance procedures described herein refer to forced warm air systems and equipment.

#### **6-36. Blower and motor maintenance.**

The blower assembly includes the blower, motor, motor base, V-belt or direct drive, and the complete housing. Following is a description of normal operating and maintenance procedures for V-belt driven blower and direct drive blower assemblies.

##### *a. V-belt driven blower.*

(1) *Blower speed adjustment.* The motor pulley is usually adjustable for a wide range of speeds. Adjust the speed of the blower to deliver the volume of air called for in the specifications. After

this has been done and a change of blower speed is required, make the change by adjusting the motor pulley, then resetting the belt tension. A simple way to determine the proper volume of air is to hold a handkerchief at the top of the warm air outlet and let the moving air raise it. Velocity should be such that the handkerchief is blown almost horizontal. Every installation having a substantial number of warm air furnaces should have a direct reading instrument for determining actual air velocities. To adjust the motor pulley, loosen the setscrew (figure 6-28) and separate the two pulley faces to decrease blower speed. Bring the faces closer together to increase speed. When locking the pulley adjustment with the setscrew, be sure to force the setscrew down on the flat surface of the pulley shaft and not on the threads.



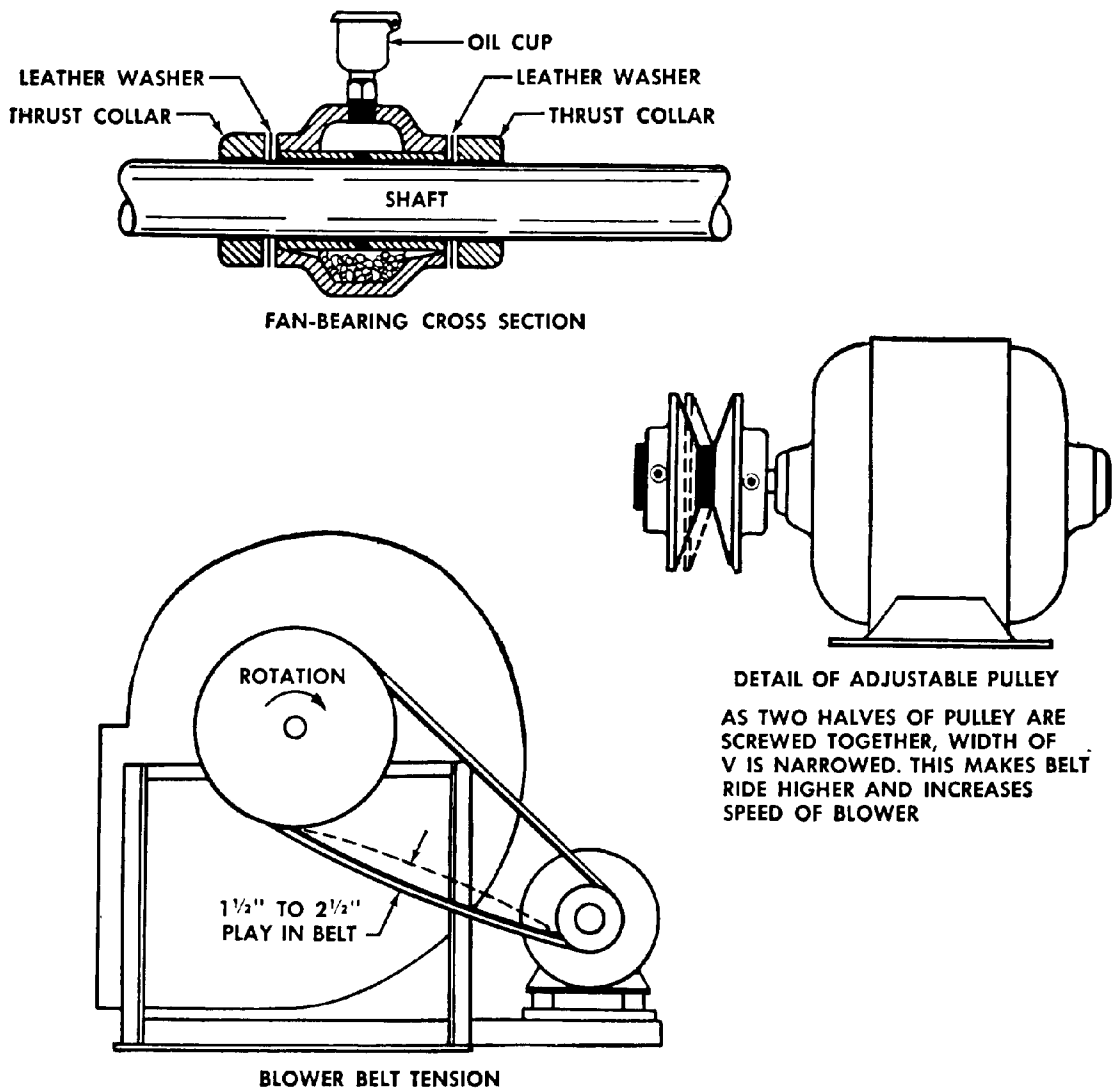

Figure 6-28. Fan bearing, pulley, and belt adjustments.

(2) *Belt tension adjustment.* To adjust belt tension, slide the motor on its base. Every motor has an adjustment for this purpose. Unless a manufacturer specifically recommends a tighter adjustment, leave from 1½ to 2½ inches up and down slack in the middle of the belt, depending on its length. (See figure 6-28.) If a V-belt is adjusted too tight it will wear rapidly and seriously overload the motor. If it is too loose, it will slip.

(3) *Alignment.* Check motor pulley and blower alignment on each installation, using a straight edge. The motor shaft is usually long enough to allow for this adjustment. However, if the alignment adjustment cannot be made by this method, move the motor into proper position.

(4) *Blower bearing adjustment.* Most blowers have bearings that are self-aligning. Some, howev-

er, have bearings that are held in alignment by bolts that anchor the bearings to the blower. For bearings of this type, check alignment; if bearings are binding, loosen bolts, bring into alignment, and retighten bolts.

(5) *Thrust collar adjustment.* Thrust collars are locked to the shaft on each side of one of the blower bearings. These collars keep the blower wheel in alignment and, when properly set, eliminate end play. If a thumping noise occurs in the blower, there is excessive end play. This noise may be eliminated by setting the thrust collar closer. Exercise care to set collars as closely as possible without binding. With either type of bearing, remove the belt and rotate the blower wheel to be sure it moves freely.

(6) *Lubrication of blower and motor.* Oil the motor and blower bearings when the unit is placed in service and periodically during the heating season according to manufacturer's instructions. Use the proper grade oil for blower and motor bearings in accordance with applicable technical manuals and manufacturer's instructions.

*b. Direct drive blower.* Figure 6-29 shows a typical arrangement of a blower with direct drive.

(1) *Blower speed adjustment.* In alternating current applications, the blower speed is limited to the available motor speed. For example, a two speed motor will provide two blower speeds. In direct current applications, motor controllers are installed to provide a wide range of blower speed variation.

(2) *Other maintenance.* Procedures for motor and blower alignment and lubrication, and adjustment of blower bearings and thrust collars are the same as previously described for belt driven blowers.

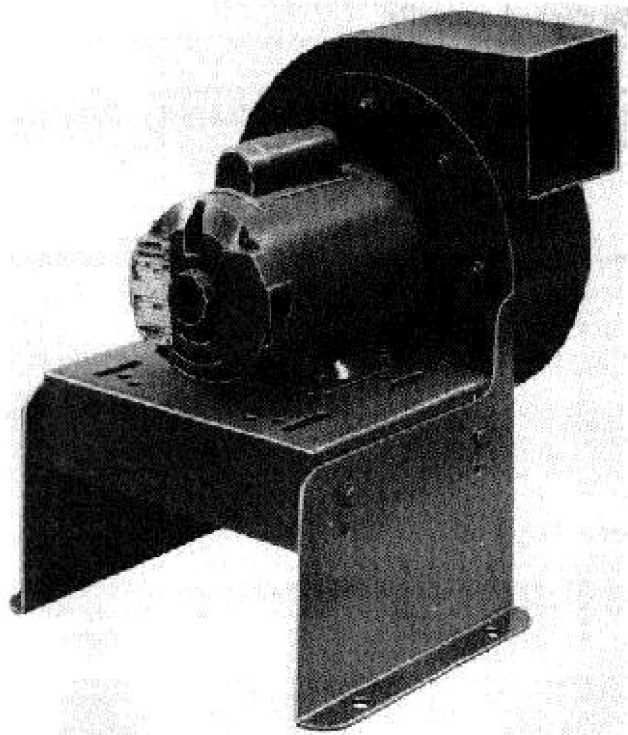

Figure 6-29. Direct drive blower.

*c. Heat exchangers and burners.* Clean with a vacuum and/or brush.

### 6-37. Air filter maintenance.

*a. Replaceable type filters.* Dirty filters impede air circulation, regardless of blower speed. If little or no air passes over the furnace, the building will be insufficiently heated and the furnace will over-

heat, which may result in serious damage. Inspect filters often. If filters are dirty or air circulation is obviously impaired, replace filters.

*b. Permanent washable type filters.* For permanent washable type filters, follow carefully cleaning directions supplied by filter manufacturer or consult applicable technical manuals. Washable filters should be renewed with adhesive spray following cleaning to enable them to pick up dust effectively.

*c. Electronic air cleaners.* This type unit employs the principle of electrostatic precipitation. Particles in the air entering the unit become positively charged and are attracted by the negatively charged collector plates and held there. Periodic washing of collector plates is required. Application of adhesive coating on a prefilter may be required. Follow carefully manufacturers' instructions for proper maintenance of these units.

*d. Activated charcoal filters.* These filters are installed in the return air plenum of warm air furnaces or in self-contained purifying units consisting of one or more activated charcoal filters, blower, and housing. Disposable filters should be replaced periodically per manufacturers' recommendations. Manufacturer's instructions should be followed for the maintenance of permanent filters.

### 6-38. Humidifiers.

*a. Pan type humidifiers.* Most humidifiers used in Army warm air systems are the pan type with a float to regulate the water level (figure 6-30). Because of the high temperature to which the float valve is subjected, it frequently sticks in an open or closed position. To release the valve, move the float ball up and down to allow water pressure to clean the dirt or other accumulation from the seat. Frequent jiggling of this float control will prevent sticking. If water is comparatively free of solids, the humidifier float seldom requires service. If the water condition is bad however, considerable difficulty may arise. It is of prime importance to check the installation of the pan to see that it does not overflow on the combustion chamber or radiator of the furnace. Pan type humidifiers must be regularly cleaned to prevent accumulation of minerals precipitating from the water. Chemicals specifically made for use in humidifiers can be added to the pan to keep minerals in suspension until they can be flushed out. Biocides are also available which can be added to the pan to prevent algae and bacteriological growth. At the end of each heating season, turn off the water supply, clean the humidifier and leave it empty until the next heating season.

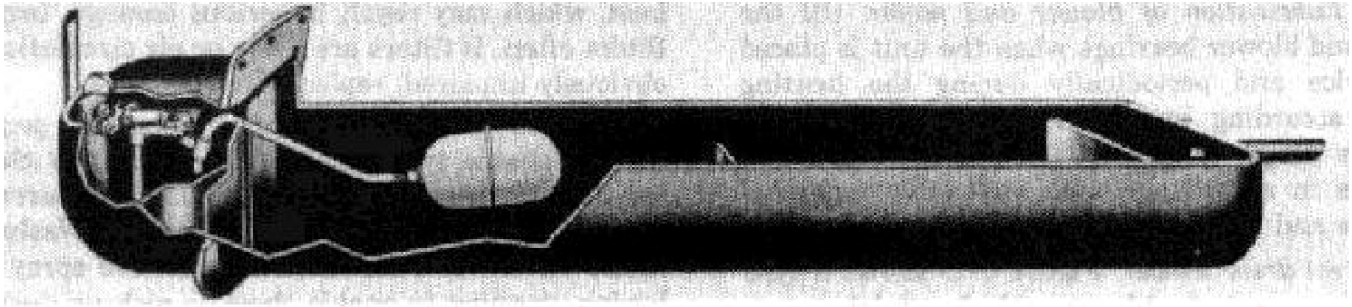
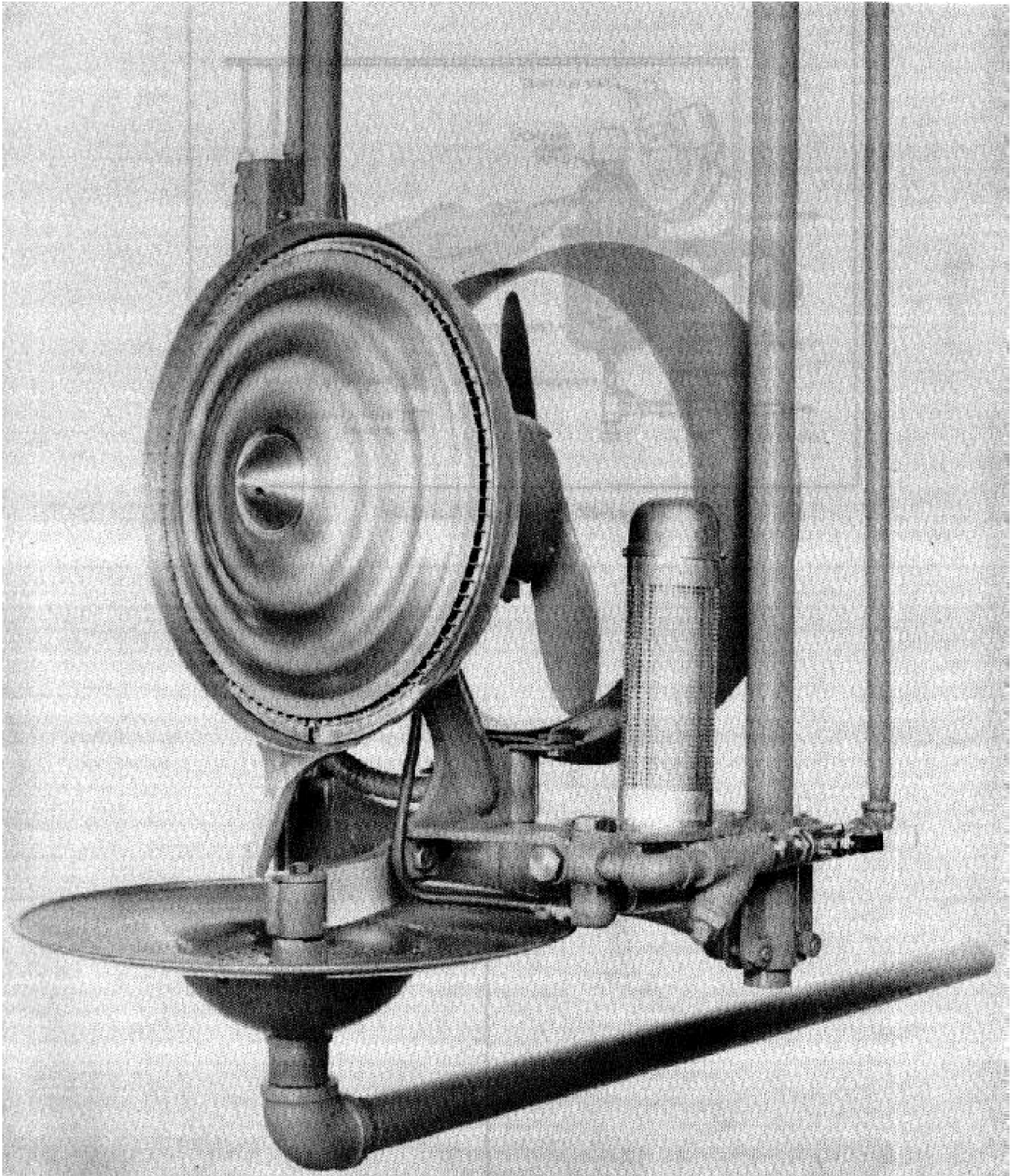

Figure 6-30. Pan type humidifier.

*b. Other humidifiers.* Other types of humidifiers used on Army installations are the centrifugal atomizer, steam spray, and steam jacketed manifold types. With the centrifugal atomizer type (figure 6-31) a high speed rotating disc imparts motion to a fine stream of water directed against its center. Stationary blades further atomize the water and direct it away from the disc and housing. With the steam spray humidifier (figure 6-32) dry mineral free steam is produced and discharged directly into the atmosphere. With the steam jacketed manifold humidifier (figure 6-33) steam is dried and purified by passing it through

a separator, superheating it, and then distributing it through a steam jacket manifold. Steam that has been treated with amine type chemicals should not be used for direct humidification. These chemicals are toxic and are carried over with steam. Steam is normally free from minerals and thus mineral accumulation on steam humidifiers is not a problem. It is good practice however, to clean this type of humidifier each year to prevent nozzles from clogging. Centrifugal humidifiers and surrounding ductwork should also be cleaned annually.



*Figure 6-31. Centrifugal atomizer humidifier.*

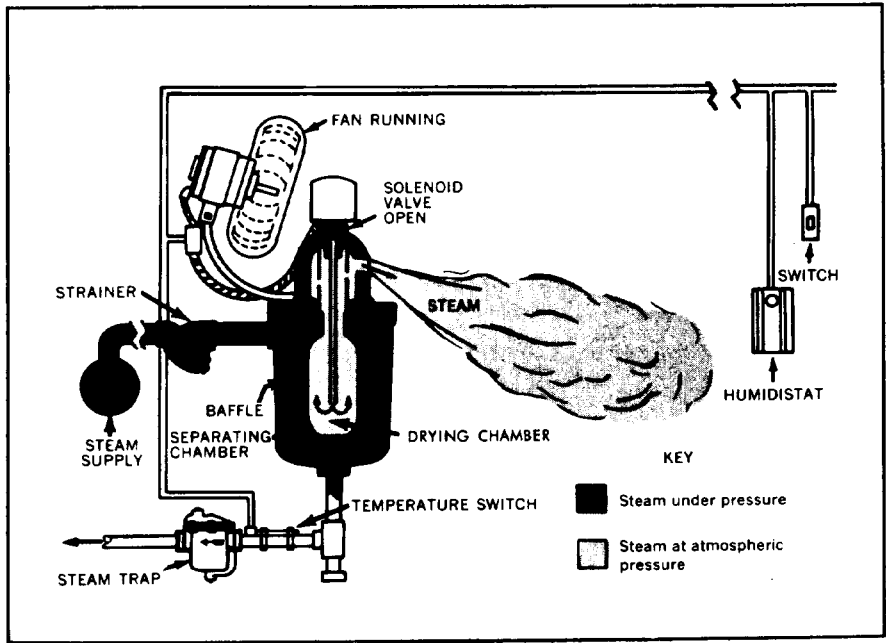

Figure 6-32. Steam spray humidifier.

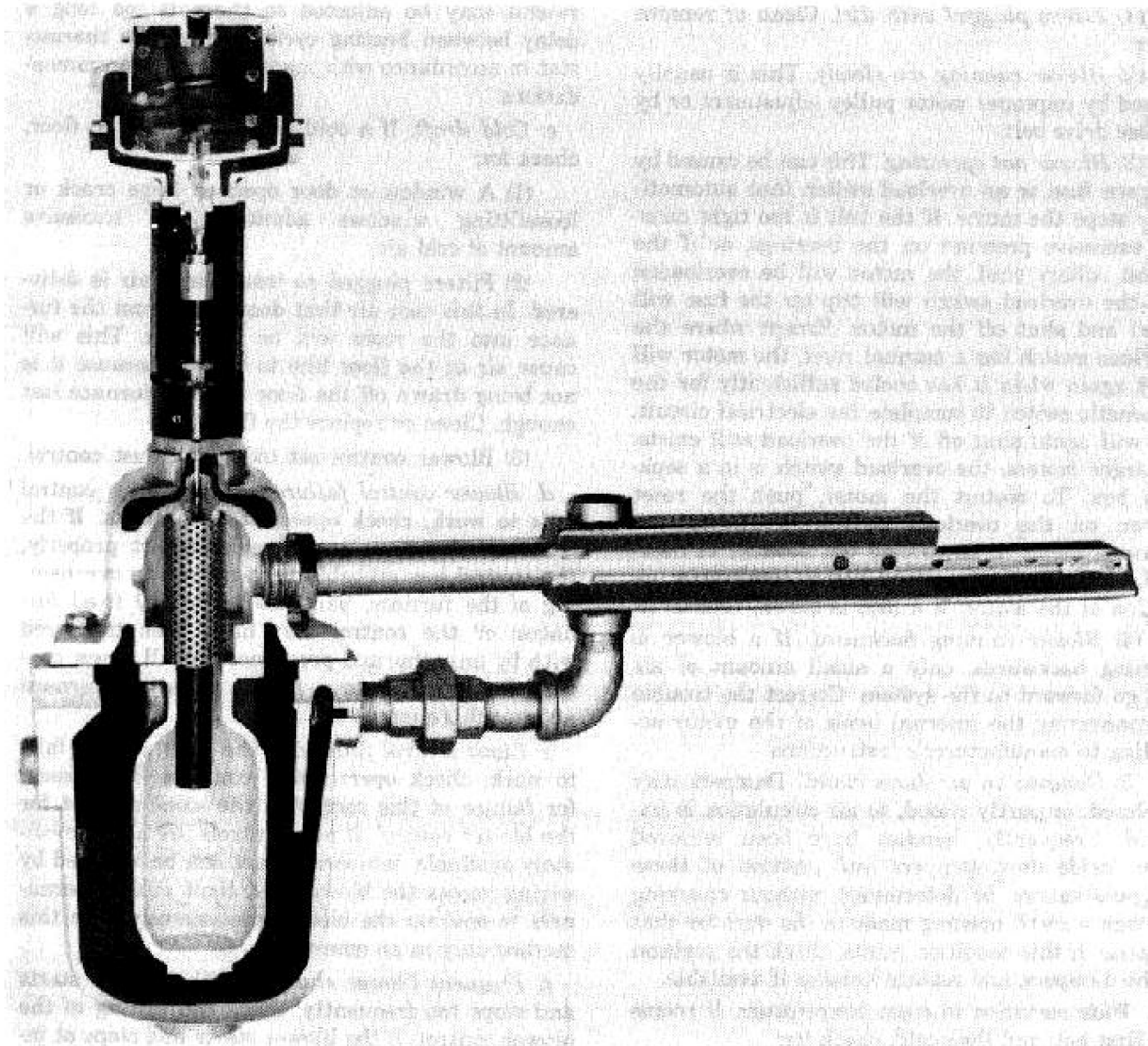

Figure 6-33. Steam jacketed manifold humidifier.

### 6-39. Blower and limit controls.

A combination blower and limit control is generally installed in the top of the furnace casing in an opening provided by the manufacturer. It is installed 10 to 18 inches above the top of the combustion chamber and in a location that is easily accessible for inspection and adjustment.

*a. Blower control adjustment.* Set blower control, or furnacestat, to stop blower between 90F and 100F in the plenum chamber. Adjust the control to start blower at 115F for gas or oil, and 125F for coal. The blower should run almost continuously when the outside temperature is 40F or below. The more continuously the blower runs, the better the building will be heated, particularly in cold weather. A slightly higher temperature setting

may be used in cold climates, or where a long duct is installed, or to meet some other local condition.

*b. Limit control adjustment.* Set the limit control to turn off the fire at 175F in milder climates and 200F in colder climates, and to turn it back on at 155F in milder climates and 170F in colder climates. Never set the limit control any higher than necessary to keep the building at the proper temperature.

### 6-40. Troubleshooting.

Common operating difficulties and methods of correcting them are outlined below.

*a. Insufficient heat.* If not enough heat is supplied, check for:

(1) *Filters plugged with dirt.* Clean or remove filter.

(2) *Blower running too slowly.* This is usually caused by improper motor pulley adjustment or by a loose drive belt.

(3) *Blower not operating.* This can be caused by a blown fuse or an overload switch that automatically stops the motor. If the belt is too tight causing excessive pressure on the bearings, or if the thrust collars bind, the motor will be overloaded and the overload switch will trip (or the fuse will blow) and shut off the motor. Except where the overload switch has a manual reset, the motor will start again when it has cooled sufficiently for the automatic switch to complete the electrical circuit, but will again shut off if the overload still exists. In larger motors, the overload switch is in a separate box. To restart the motor, push the reset button on the overload switch. Whenever the motor is found to be cutting out because of overload, eliminate the overload before continuing operation of the motor. If a fuse is blown, replace it.

(4) *Blower running backward.* If a blower is running backwards, only a small amount of air will go forward to the system. Correct the trouble by connecting the internal leads of the motor according to manufacturer's instructions.

(5) *Dampers in air ducts closed.* Dampers may be closed, or partly closed, so air circulation is impeded. Frequently, handles have been removed from inside duct dampers and position of these dampers cannot be determined without checking through a small opening made in the duct for that purpose. If this condition exists, check the position of the dampers, and replace handles if available.

*b. Wide variation in room temperature.* If rooms are first hot, and then cold, check for:

(1) *Blower control set too high.* If the blower control setting is too high, the blower will not start until the furnace is very hot and a surplus of heat is then blown into the building. Set blower control down in accordance with recommendations for blower control settings. To test for this condition, turn on the manual switch controlling the blower and permit it to operate continuously. If this relieves the condition, the blower control is set too high.

(2) *Room thermostat out of adjustment.* The throttling range or anticipator setting on the thermostat may be adjusted so there is too long a delay between heating cycles. Adjust the thermostat in accordance with manufacturer's recommendations.

*c. Cold draft.* If a cold draft is noticed on floor, check for:

(1) A window or door open or large crack or loosefitting windows admitting an excessive amount of cold air.

(2) Filters plugged so insufficient air is delivered. In this case air that does come from the furnace into the room will be very hot. This will cause air at the floor line to be cold because it is not being drawn off the floor into the furnace fast enough. Clean or replace the filters.

(3) Blower control set too low; adjust control.

*d. Blower control failure.* If the blower control fails to work, check operation of contacts. If the control fails to make or break contact properly, the control has probably been ruined by overheating of the furnace, particularly in coal fired furnaces; or the control may have been tampered with by unauthorized personnel. Install a new control. Do not operate a forced warm air furnace without this control.

*e. Limit control failure.* If the limit control fails to work, check operation of contacts. The reason for failure of this control is the same as that for the blower control. If new controls are not immediately available, temporary heat can be obtained by wiring across the blower and limit control terminals to operate the blower continuously. Use this method only in an emergency.

*f. Frequent blower shutoff* If the blower starts and stops too frequently, check the setting of the blower control. If the blower starts and stops at intervals of 2 or 3 minutes, motor life will be shortened. This also overheats the overload switch in the blower control. Increase the differential between starting and stopping temperatures on blower control by 10F. This will usually overcome the difficulty.

*g. High outlet temperature.* Outlet temperature should not exceed 160F for an extended period of time. The most frequent cause of high outlet temperature is insufficient airflow. This can be caused by blocked filters, too low a fan speed, or restricted ductwork.

## Section VIII. ENERGY CONSERVATION

### 6-41. Space temperature setback.

Energy expended to heat buildings to comfort conditions when they are unoccupied is wasted. Save energy by setting back the temperature level at these times. The savings which can result vary with the length of time and the number of degrees that temperatures are set back. The percentage savings will be greater in warmer climates, but the gross energy saved will be greater in cold climates. In areas where it is not necessary to maintain high temperatures during occupied periods, i.e. corridors and lobbies, maintain even lower temperatures than for the other spaces. Implement setback by resetting thermostats manually (if automatic setback control has not been installed), or adjusting controls to suggested temperatures (if clock, day-night, or other automatic reset controls are available). Climate, type of system, and building construction will determine the length of the startup period required to attain daytime temperature levels. Experiment to decide upon the optimal setback temperature and startup time for any particular building. If, in extremely cold weather, experience indicates that the heating system does not raise the temperature sufficiently by the time the building opens for the day, set temperatures back to a level higher than those recommended here for those periods of time only. So called "smart thermostats" and computerized Energy Monitoring and Control Systems (EMCS) automatically calculate the most effective time to end setback.

### 6-42. Maintenance of duct insulation.

*a.* Warm air ducts are commonly installed without insulation and are typically routed from the equipment room through unoccupied spaces, shafts, and ceiling voids where their heat loss is unproductive in meeting the occupied space heating load. Although the temperature difference between duct and ambient temperature is relatively small, heat loss in long duct runs can be significant.

*b.* Of equal importance is the temperature drop of supply air that accompanies heat loss. In long duct runs serving many rooms on one zone, this will result in the last room having a lower supply air temperature than the first. The tendency in this case is to heat the last room to comfort conditions resulting in overheating in each preceding room.

*c.* Warm air ducts may be insulated with rigid fibrous material stuck on or fixed with special clips or bands. They may also be insulated with flexible mats clipped or wired on (this is particularly applicable for round or oval ducts). Ducts may also be insulated with spray-on foam or fibrous material as used for insulating undersides of roofs. It is worth considering insulating roofs and ducts as one contract.

*d.* Insulation applied to ducts supplying only warm air need not be vapor sealed. Insulation applied to ducts supplying warm air in winter and cold air in summer must be vapor sealed to prevent condensation forming within the insulation.



## APPENDIX A

### RELATED PUBLICATIONS

---

#### Government Publications.

##### *Department of the Army.*

TM 5-650	Central Boiler Plants
TM 5-745	Heating, Ventilating, Air Conditioning and Sheet Metal Works
TM 5-785	Engineering Weather Data
TM 5-810-1	Mechanical Design-Heating, Ventilating and Air Conditioning
TM 5-843-3	Ground Storage of Coal

##### *Non-Government Publications.*

*Air Conditioning and Refrigeration Institute (ARI)*, 1501 Wilson Blvd., 6th Floor., Arlington, VA 22209

Guideline F-88                      Selection, Installation and Servicing of Residential Humidifiers

##### Standards:

610-82	Central System Humidifiers
670-85	Fans and Blowers
680-86	Residential Air Filter Equipment

*American Boiler Manufacturers Association (ABMA)*, Suite 160, 950 N. Glebe Rd., Arlington, VA 22203

Boiler Water Limits and Steam Purity Recommendations for Watertube Boilers (3rd Edition, 1982)

Boiler Water Requirements and Associated Steam Purity for Commercial Boilers (1st Edition, 1984)

Guidelines for Burner Adjustments of Commercial Oil-Fired Boilers

A Guide to Clean and Efficient Operation of Coal Stoker Fired Boilers

Lexicon — Boiler and Auxiliary Equipment (5th Edition, 1987) Operation and Maintenance Safety Manual

Thermal Shock Damage to Hot Water Boilers as a Result of Energy Conservation Measures

*American Gas Association (AGA)*, 1515 Wilson Blvd., Arlington, VA 22209

Directory of Certified Appliances and Accessories

##### Standards:

Z21.8-84	Installation of Domestic Gas Conversion Burners
Z21.13-87	Gas-Fired Low Pressure Steam and Hot Water Boilers
Z21.47-87	Gas-Fired Central Furnaces
Z21.66	Automatic Vent Damper Devices for Use with Gas-Fired Appliances
Z83.6-87	Gas-Fired Infrared Heaters
Z83.8-85	Gas Unit Heaters

*American Society of Heating, Refrigeration, and Air Conditioning Engineers (ASHRAE)*, 1791 Tullie Circle, NE., Atlanta, GA 30229

##### Handbooks:

HVAC Systems and Applications, 1987

Equipment, 1988

Fundamentals, 1989

*American Society of Mechanical Engineers (ASME)*, 45 East 47th Street, New York, NY 10017  
Boiler and Pressure Vessel Code, and Interpretations:

- Section IV                    Construction of Heating Boilers
- Section VI                  Recommended Rules for Care and Operation of Heating Boilers
- Section VIII                Pressure Vessels, Division 1

*National Fire Protection Association (NFPA)*, Batterymarch Park, Quincy, MA 02269 National Fire Codes:

- 31                              Standard for Installation of Oil Burning Equipment
- 54                              National Fuel Gas Code
- 85A                            Standard for Prevention of Furnace Explosions in Fuel-Oil and Natural Gas-Fired Single Burner Boiler Furnaces
- 851                            Recommended Practices for Stoker Operation

*Sheet Metal and Air Conditioning Contractors' National Association (SMACNA)*, 8224 Old Courthouse Rd., Vienna, VA 22180

- HVAC Duct Construction Standards, Metal and Flexible
- HVAC Systems — Testing, Adjusting and Balancing
- Installation Standards for Heating, Air Conditioning and Solar Systems

## APPENDIX B

### TROUBLESHOOTING UNDERFEED STOKERS

<i>Symptom</i>	<i>Probable cause</i>	<i>Remedy</i>
Using too much fuel.	Thin fuel bed due to excess air from fan.	Decrease air supply or increase coal feed.
	Thin fuel bed due to too much draft.	Adjust overfire draft by resetting dampers, or installing automatic dampers.
	Dirty heating surface.	Keep heating surfaces clean of soot and fly ash.
Insufficient heat.	Not enough coal feed (thin fuel bed).	Increase rate of feed and adjust air from fan.
	Fuel bed too deep.	Increase air supply, decrease fuel feed.
	Improper furnace draft.	See that overfire draft is sufficient to carry away products of combustion. Check design and condition of chimney.
	Limit control set too low.	Adjust limit control to weather conditions. Increase settings during cold weather, decrease during warm weather.
Excessive heat.	Fuel bed too heavy.	Decrease coal feed, adjust air supply.
	Limit control set too high.	Lower setting.
	Hold-fire or out-fire control set improperly,	Hold-fire controls are made to keep fire from going out. Set to hold fire only; set 2 minutes for each ½ hour.
	Excess furnace draft. (Fire goes out during off period)	Adjust draft controls to lower draft.
	Insufficient draft.	Chimney may be blocked or too small. Reset draft controls to increase draft.
	Insufficient air in furnace room.	Increase combustion air openings in furnace room.
	Dirty fuel bed.	Remove excess fly ash and clinkers from fire.
	Coke trees.	Adjust air supply to fuel feed, check furnace draft.
	Overload or pin sheared.	Clinker in retort. Maintain clean fires and proper adjustment of stoker.

<i>Symptom</i>	<i>Probable cause</i>	<i>Remedy</i>
Smoke from chimney.	Obstruction in feed tube.	Shut off stoker and remove obstruction.
	Feed screw worn or broken.	Replace feed screw.
	Coke ball in retort.	Remove coke ball, adjust feed and air supply.
	Insufficient combustion air.	Increase air. Check tuyere openings, windbox, fan blade and heating surfaces; clean if necessary.
Smoke from fire door.	Insufficient combustion space.	Consult stoker manufacturer.
	Insufficient furnace draft or too much air from fan.	Increase draft or reduce fan air.
Coke trees or coke bed.	Incorrect coal/air ratio.	Keep slide in fire door open. If coke bed is heavy, increase air or decrease coal feed. If tree is thin, reduce air or increase coal.
Fly ash.	Thin fuel bed.	Increase coal feed, adjust air supply.
	Dirty fuel bed.	Clean.
Soot.	Fuel bed too thick.	Increase air or decrease coal feed.
	Insufficient combustion space.	Consult stoker manufacturer.
Hopper smoke.	Fire burning in retort when stoker is idle.	Set damper. If trouble continues, increase coal feed or set time delay to run longer or more frequently.
	Dirty fires.	Remove clinkers, especially from retort.
	Insufficient furnace draft.	Increase draft.
	Hopper empty.	Fill.
	Siftings in windbox.	Clean windbox.
	Hopper lid not sealed.	Refit lid.
	Smoke eliminator tubes clogged. (Some stokers do not have this tube.)	Clean tubes.
	Feed screw not turning.	Determine reason and correct it.
	Coal too coarse.	Add fire coal.

## APPENDIX C

## TROUBLESHOOTING STEAM PRESSURE PUMPING SYSTEMS

<i>Symptom</i>	<i>Probable cause</i>	<i>Remedy</i>
Unit fails to fill:		
Increase in liquid level in receiver, possible flood in receiver.	Obstruction in fill line, valve closed, swing check backwards.	Inspect fill line for closed valve, swing check installed backwards, or obstruction in fill line. Refer to assembly and parts list.
Increase in liquid level in receiver, possible flood in receiver, increase in receiver pressure.	3-way valve assembly leaking.	Inspect valve assembly.
Receiver empty, level fluctuating.	Receiver pressure greater than pressure in discharge line.	If unit has been in operation for a period of time without problems, check for traps blowing through. If new installation, receiver pressure may be greater than anticipated; back pressure may be less than anticipated. A 2-way control valve may be required in discharge line
Unit fills too slowly or 3-way valve will not deenergize:		
No liquid level in receiver.	Load to unit not as great as anticipated.	No action required.
Receiver flooding.	Obstruction or restriction in fill line.	Inspect fill line for partially closed valve. Inspect fill line for proper size fittings and pipe.
	Restriction in vent line, 3-way valve assembly out of adjustment.	Inspect vent line for partially closed valve, proper size fittings and pipe. Inspect 3-way valve assembly.
Unit fills very rapidly:		
Unit cycling almost normally, receiver flooding	Defective check valve in discharge line. Back flow to system.	Inspect discharge check valve.
Noise in or at fill line check valve:		
Vibration and water hammer at fill line check valve.	Cold condensate.	Inspect for cold condensate. Throttle flow control valve, ahead of 3-way steam valve assembly.
Unit discharges very rapidly:		
Water hammer.	Motive pressure too high.	Throttle flow control valve.
Receiver flooding, rise in receiver pressure during discharge.	Defective check valve in fill line. Discharging condensate back into receiver.	Inspect fill line check valve.

<i>Symptom</i>	<i>Probable cause</i>	<i>Remedy</i>
Unit discharge cycle too long: Possible receiver flooding, discharge time greater than 30 seconds.	Flow control valve throttled too much.	No action required if receiver not flooding. If receiver flooding, adjust flow control valve for discharge of approximately 24 seconds.
Rumble and vibration from unit chamber, possible receiver flooding, discharge time greater than 30 seconds.	Cold condensate. Unit may be sized for future requirement. Condensate sub-cools.	Inspect for cold condensate. Throttle control valve slightly. If unit sized for future load, extend length of short electrode.
Receiver flooding, discharge time greater than 30 seconds.	Restriction or increase of back pressure in discharge line.	Inspect discharge line for partially closed valve(s), obstructions or change in pressure. If pressure increases, may require adjustment of flow control valve.
No steam flow. Receiver flooding.	Steam supply failure, obstruction in steam supply line,	Inspect for supply steam pressure, closed valve or obstruction in steam supply line. Inspect strainer.
3-way valve noisy.	Condensate in steam supply line.	Inspect steam supply line for condensate.
Receiver pressure increase during discharge.	3-way valve out of adjustment. Steam leakage into receiver.	Adjust valve.

## BIBLIOGRAPHY

---

Burkhardt, Charles H., *Domestic and Commercial Oil Burners*, McGraw-Hill Book Company, New York, NY 10020

Cooper, William B., *Warm Air Heating for Climate Control*, Prentice-Hall, Inc., Englewood Cliffs, NJ 07632

Faulkner, Edward A., Jr., *Guide to Efficient Burner Operation*, Fairmont Press, Inc., Atlanta, GA 30324

Payne, William F., *Efficient Boiler Operations Sourcebook*, Fairmont Press, Inc., Atlanta, GA 30324

Smith, Russell E., *Electricity for Refrigeration, Heating and Air Conditioning*, Breton Publishers, Wadsworth Inc., Belmont, CA 94002

## GLOSSARY

### Section I. ABBREVIATIONS

ABMA . . . . .	American Boiler Manufacturers Association	gph . . . . .	Gallons per hour
AGA . . . . .	American Gas Association	H <sub>2</sub> . . . . .	Hydrogen
ARI . . . . .	Air Conditioning and Refrigeration Institute	HRT . . . . .	Horizontal return tubular
ASHRAE . . .	American Society of Heating, Refrigeration and Air Conditioning Engineers	HTHW . . . . .	High temperature hot water
ASME . . . . .	American Society of Mechanical Engineers	HW . . . . .	Hot water
AVD . . . . .	Automatic Vent Damper	IPS . . . . .	Iron pipe size
BTU . . . . .	British thermal unit	LPG . . . . .	Liquified petroleum gas
BTUH . . . . .	British thermal units per hour	mu . . . . .	One thousandth of an inch
CO . . . . .	Carbon Monoxide	NFPA . . . . .	National Fire Protection Association
CO <sub>2</sub> . . . . .	Carbon Dioxide	O <sub>2</sub> . . . . .	Oxygen
EDR . . . . .	Equivalent direct radiation	ppm . . . . .	Parts per million
EMCS . . . . .	Energy Monitoring and Control System	psi . . . . .	Pounds per square inch
F . . . . .	Degrees Fahrenheit	psia . . . . .	Pounds per square inch, absolute
F&T . . . . .	Float and thermostat	psig . . . . .	Pounds per square inch, gauge
FIA . . . . .	Factory Insurance Association	PRV . . . . .	Pressure reducing valve
FM . . . . .	Factory Mutual	PVC . . . . .	Polyvinyl chloride
fpm . . . . .	Feet per minute (measure of velocity)	RF . . . . .	Radio frequency
		SMACNA . . .	Sheet Metal and Air Conditioning Contractors' National Association
		UL . . . . .	Underwriters Laboratories, Inc.

### Section II. TERMS

Alkali—A substance with a characteristically acid taste and having the ability to neutralize acids. May be caustic.	Bimetallic element—A device consisting of two different metals fastened together which bends in a certain direction depending on the temperature. Commonly used in thermostats.
Amine-free steam—Steam with no trace of ammonia.	Clinker—The incombustible residue, fused into an irregular lump that remains after the combustion of coal.
Anthracite Buckwheat coal—A hard natural coal, containing little volatile matter, commonly used in mechanical types of firing equipment.	Combustion—Burning, or a chemical change which produces heat and light.
Aquastat—A device which regulates the water temperature in a boiler.	Corrosion—The process of rusting, or wearing away, of metals.
Atmospheric pressure—The average pressure on the surface of the earth at sea level, or 14.7 psia.	Distillate fuel oil—A light, volatile substance, such as No. 2 oil, produced by fractional distillation of petroleum.
Atomization—Transforming to a fine spray.	Draft hood—A device, usually integral to a furnace, which maintains furnace draft by admitting room air into the vent.
Automatic vent damper—A thermally or electrically actuated damper, located on a furnace or boiler vent, which closes when the heating equipment is between firing cycles.	Eductor—A device to draw air out.
Barometric draft control—A damper, mounted on the vent stack of a furnace or boiler, which maintains the draft at a constant level.	Efficiency—The ratio of effective or useful output to total input in any system.



## TM 5-642

- Fractional distillation—A heat dependent process used to separate a substance into pure fractions.
- Fully condensing furnace—A furnace designed with sufficient heat transfer surface to condense moisture from the flue products, thereby increasing furnace efficiency.
- Gauge glass—A device used on a steam boiler that provides a visual indication of boiler water level.
- Gravity heating system—A system in which the heating medium circulates naturally because of the temperature difference between the supply and return medium.
- Hartford Loop—A boiler piping configuration which eliminates unsafe lowering of boiler water level due to back up of boiler water into the return line.
- Humidifier—A device that adds moisture to a space to maintain a certain relative humidity.
- Infrared heater—A system consisting of a hot surface that heats surrounding objects through infrared radiation.
- Infrared photometer—A meter measuring strength of infrared radiation, electromagnetic radiation with wavelengths greater than that of visible light and shorter than microwaves.
- Latent heat—Heat needed to change the phase of a substance, such as water changing to steam.
- Limit control—A device which will shut down a boiler or furnace if a parameter, such as steam pressure or supply air temperature, exceeds a predetermined level.
- Millivoltmeter—A device which measures voltage at the scale of millivolts, or thousandths of a volt.
- Motive pressure—Line velocity pressure in steam piping.
- Non-ferrous—Not containing any iron.
- Pilotstat—A device which senses the presence of a pilot flame and allows the main gas burner to ignite.
- Pneumatic system—A compressed air system, used commonly for controls.
- Polarity—An alignment of orientation of two objects to opposite extremes.
- Primary controls—Sensors and actuating devices that directly operate the heating system in accordance with demands of the space thermostat.
- Pyrometer—An electrical thermometer for measuring high temperatures.
- Retort—The central trough into which coal is fed in certain types of boilers.
- Residual fuel oil—Heavy, thick substance, such as No. 6 oil, left over from the distillation of petroleum.
- Run-of-mine coal—Commonly used for domestic heating and steam production, this coal is shipped as it comes from the mine without screening.
- Scale—A flaky oxide film formed on a metal such as iron when heated to high temperatures.
- Steam trap—A device designed to pass only condensate and air from a steam system, while trapping steam.
- Stethoscope—An instrument used to listen to sounds inside of a pipe.
- Stoker—A mechanical device which feeds coal to a furnace.
- Thermocouple—A device which measures temperature by means of thermoelectric energy.
- Tuyere—The opening through which air is forced into a blast furnace to facilitate combustion.
- Unit heater—A heating device, usually located directly in the space to be heated, consisting of a fan and a heat source.
- Vapor pressure—The pressure exerted by a vapor in equilibrium with its solid or liquid phase.
- Vaporization—The process of a solid or liquid becoming a gas.
- Viscosity—The degree to which a fluid resists flow under an applied force.

## INDEX

---

- Air filters, 6-37
- Air vents
  - Description of, 4-47
  - Installation and operation of, 4-48
  - Maintenance of, 4-49
  - Typical operating difficulties with, 4-50
- Automatic controls
  - Barometric dampers, 7-13
  - Combustion safeguards, 7-13
  - Draft controllers, 7-13
  - Electric, 7-1
  - Electronic, 7-1
  - Fan and limit control, 7-11
  - Feedwater regulators, 7-13
  - For coal stoker, 7-8
  - For gas burner, 7-10
  - For hand-fired coal furnace, 7-7
  - For hot water boiler, 7-11
  - For oil burner, 7-9
  - For steam boiler, 7-11
  - For warm-air furnace, 7-11
  - Low-water cutoffs, 7-13
  - Operation and maintenance of, 7-5, 7-6, 7-7
  - Pilotstat, 7-12
  - Pneumatic, 7-1
  - Primary type, 7-3, 7-7, 7-8, 7-9, 7-10
  - Safety pilot, 7-12
  - Smoke alarms, 7-13
  - Thermostats, 7-2, 7-6
  - Types of, 7-1
- Automatic vent dampers, 6-25
- Blow-down pipes, 4-42
- Boilers
  - Burners for. See Burners
  - Cast iron, 4-7
  - Cleaning, initial, 4-11
  - Condensate pumps. See Pumps, condensate
  - Controls for. See Automatic controls
  - Fire-tube, 4-9
  - Installation of, 4-13, 4-15, 4-32, 4-38
  - Lay-up of. See Summer lay-up
  - Maintenance of, 4-12, 4-14, 4-17, 4-34, 4-39, 4-71, 4-72, 4-73, 4-74, 4-75, 4-76
  - Operation of. See also Steam heating systems, Operating difficulties, 4-11, 4-18, 4-34, 4-41, 4-71, 4-72, 4-73, 4-74
  - Return traps, 4-15, 4-16, 4-17, 4-18
  - Safety valves, 4-41
  - Steel, 4-8, 4-9, 4-10
  - Vacuum pumps. See Pumps, vacuum
  - Water-tube, 4-10
- Burners, coal. See Stoker, coal; Furnaces, coal-fired
- Burners, dual fuel (oil/gas)
  - Introduction to, 3-20
  - Maintenance of, 3-22
  - Operation of, 3-21
- Burners, gas
  - Introduction to, 3-15
  - Maintenance of, 3-19
  - Mechanical-mixing type, 3-17
  - Operation of, 3-17, 3-18
  - Radiant type, 3-17
  - Register type, 3-17
  - Up-shot type, 3-17
- Burners, general
  - Air adjustment to, 3-23
  - Controls for. See Automatic controls
  - Energy conservation measures for, 3-23
  - Retrofit of, 3-23
  - Tuning of, 3-23
- Burners, oil
  - High pressure gun, 3-10
  - Horizontal rotary, 3-10
  - Ignition procedures for, 3-11
  - Low pressure gun, 3-10
  - Maintenance of, 3-13
  - Operation of, 3-12
  - Piping for, 3-14
  - Starting of, 3-11
  - Troubleshooting of, 3-13
- Coal, 2-1
- Coal-fired boilers. See Boilers; Stokers, coal
- Coal stoker. See Stoker, coal
- Controls. See Automatic controls
- Dampers, combustion air, 4-43, 6-9
- Dual fuel (oil/gas) burners. See Burners, dual fuel (oil/gas)
- Energy conservation
  - Air adjustment to burners, 3-23
  - Hot water temperature reduction, 5-18

## TM 5-642

- Isolation of off-line boilers, 4-99
- Night setback of hot water supply temperature, 5-19
- Maintenance of duct insulation, 6-42
- Maintenance of pipe and boiler insulation, 4-100
- Space temperature setback, 6-41
- Fan-coils, hot-water
  - Capacity control for, 5-11
  - Electrical requirements for, 5-12
  - Description of, 5-10
  - Maintenance of, 5-13
- Furnaces, coal-fired
  - Cast iron, 6-6
  - Chimney for, 6-10
  - Hand-fired, 3-6, 3-7, 3-8
  - Motor damper, 6-9
  - Ratings, 6-7
  - Smokepipe for, 6-8
  - Steel, 6-5
- Furnaces, gas
  - Construction of, 6-15
  - Conversion to, 6-20
  - Downflow, 6-18
  - Fully-condensing, 6-21, 6-22
  - Horizontal, 6-19
  - Pulse combustion, 6-23, 6-24
  - Rating, 6-16
  - Types of, 6-14
  - Upflow, 6-18
- Furnaces, general
  - Burners for. See Burners
  - Controls for. See Automatic controls
  - Introduction to, 6-1
  - Ratings, 6-4
- Furnaces, oil
  - Conversion to, 6-13
  - Description of, 6-11, 6-12
- Gas-conversion furnaces, 6-20
- Gas-fired boilers. See Boilers
- Gas-fired unit heaters. See Unit heaters, gas-fired
- Gas-fired warm-air furnaces. See Furnaces, gas
- Gauges
  - Glass breakage, 4-37
  - Glasses, installation of, 4-38
  - Steam pressure, 4-40
  - Testing and care of, 4-39
- Gravity systems. See Hot water heating systems; Steam heating systems; Warm-air heating systems
- Heat exchangers
  - Description of, 5-14
  - Installation of, 5-15
  - Operation of, 5-16
  - Maintenance of, 5-17
- Heating coils, steam
  - Description of, 4-59
  - Initial operation and cleaning of, 4-61
  - Installation of, 4-60
  - Maintenance of, 4-62
  - Typical operating difficulties with, 4-63
- Horizontal furnaces. See Furnaces, gas
- Hot-water fan-coil units. See Fan-coils, hot-water
- Hot-water heating systems. See also Boilers
  - Direct return, 5-8
  - Expansion tanks, 5-2, 5-7
  - Gravity, 5-1, 5-2, 5-3, 5-4, 5-5
  - Inspection and maintenance of, 5-5, 5-9
  - Piping for, 5-8
  - Pressure reducing valve for, 5-7
  - Pumps, 5-7
  - Radiator air vent, 5-2
  - Radiator valve, 5-2
  - Reversed return, 5-8
  - Series-loop, 5-8
  - Water level, 5-4
- Humidifiers, steam
  - Ducat installation of, 4-65
  - Description of, 4-64
  - Unit type, installation of, 4-66
- Infrared heaters
  - Electric, 6-31
  - Gas-fired, 6-30
  - Maintenance of, 6-34
  - Oil-fired, 6-32
  - Precautions for, 6-33
- Liquefied petroleum gas (LPG)
  - Characteristics of, 2-9
  - Description of, 2-8
  - Specifications for, 2-10
  - Butane and iso-butane, 2-10
  - Propane, 2-10
  - Handling precautions for, 2-11
  - Installation of, 2-11
  - Piping for, 2-11

- Storage of, 2-11
- Limit control. See Automatic controls
- Maintenance
  - Of air filters, 6-37
  - Of air vents, 4-49
  - Of automatic controls, 7-5, 7-6, 7-7
  - Of blowers, 6-36
  - Of boilers, 4-7, 4-12
  - Of burners, dual fuel (oil/gas), 3-22
  - Of burners, gas, 3-19
  - Of burners, oil, 3-13
  - Of coils, steam, 4-62, 4-63
  - Of duct insulation, 6-42
  - Of furnaces, 6-22, 6-24
  - Of gauge glasses, 4-37, 4-38, 4-39
  - Of humidifiers, 6-38
  - Of infrared heaters, 6-34
  - Of pipe and boiler insulation, 4-100
  - Of pressure reducing valves, 4-69, 4-70
  - Of pumps, 4-22, 4-29
  - Of radiators, 4-53, 4-54
  - Of return traps, 4-17
  - Of steam traps, 4-45, 4-46
  - Of stokers, coal, 3-3, 3-4, 3-5
  - Of unit heaters, steam, 4-57
  - Of valves and piping, 4-14, 4-72
  - Of water level, 4-73
  - Of water level regulators, 4-34
- Natural gas
  - Description of, 2-5
  - Handling and storage of, 2-6
  - Handling precautions for, 2-7
- Oils, fuel
  - Classification of, 2-3
  - Commercial grades of, 2-3
  - Diesel, 2-3
  - Distillate, 2-3
  - Residual, 2-3
  - Tanks for, 2-4
- Operation
  - Of air vents, 4-48, 4-50
  - Of automatic controls, 7-5, 7-6, 7-7
  - Of boilers, 4-11, 4-18, 4-34, 4-41, 4-71, 4-72, 4-73, 4-74
  - Of burners, dual fuel (oil/gas), 3-21
  - Of burners, gas, 3-17, 3-18
  - Of burners, oil, 3-12
  - Of coal stokers, 3-3, 3-5
  - Of infrared heaters, 6-33
  - Of pressure reducing valves, 4-68, 4-69, 4-70
  - Of pumps, 4-21, 4-23, 4-28, 4-30
  - Of radiators, 4-53, 4-54
  - Of steam traps, 4-45, 4-46
  - Of unit heaters, steam, 4-58
  - Of water level regulators, 4-33, 4-34, 4-35
- Pumps, condensate
  - Alignment of, 4-20
  - Controls for, 4-20
  - Description of, 4-19
  - Foundation for, 4-20
  - Fuses and thermal units for, 4-20
  - Installation of, 4-20
  - Maintenance of, 4-22
  - Operation of, 4-21, 4-23
  - Packing boxes, 4-22
  - Piping for, 4-20
  - Rotation, 4-20
  - Wiring, 4-20
- Pumps, vacuum
  - Cleaning of, initial, 4-28
  - Controls for, 4-27
  - Description of, 4-25
  - Installation of, 4-26
  - Lubrication of, 4-29
  - Maintenance of, 4-29
  - Packing boxes, 4-29
  - Operation of, 4-28, 4-30
- Pressure reducing valves
  - Types of, 4-67
  - Installation of, 4-68
  - Operation and maintenance of, 4-68, 4-69
  - Typical operating difficulties with, 4-70
- Pulse combustion furnaces. See Furnaces, gas
- Radiators, steam
  - Description of, 4-51
  - Initial operation and cleaning of, 4-53
  - Installation of, 4-52
  - Typical operating difficulties with, 4-54
- Safety valves, 4-41
- Steam heating systems. See also Boilers
  - Description of, 4-1, 4-2
  - Gravity, one-pipe, 4-3
    - Energy conservation measures for, 4-99, 4-100, 4-101
  - Operating difficulties with, 4-77, 4-78, 4-79, 4-80, 4-81, 4-82, 4-83, 4-84, 4-85, 4-86, 4-87

## TM 5-642

- Summer lay-up procedures for. See Summer lay-up
- Two-pipe, vacuum, 4-6
- Two-pipe, with condensate pump, 4-5
- Two-pipe, with return trap, 4-4
- Steam pressure pumping systems, 4-24
- Steam traps
  - Boiler return. See Boilers, Return traps
  - Bucket, 4-46
  - Cleaning of, 4-46
  - Description of, 4-44
  - Float, 4-46
  - Installation of, 4-45, 4-46
  - Leak detection for, 4-101
  - Maintenance of, 4-45, 4-46
  - Operation of, 4-45, 4-46
  - Thermostatic, 4-45, 4-46
- Stokers, coal
  - Cleaning of, 3-3
  - Draft requirements for, 3-3
  - Fire requirements for, 3-3
  - Inspection and maintenance procedures for, 3-4
  - Lay-up of, 3-3, 4-9
  - Lubrication of, 3-3
  - Operation of, 3-3
  - Single-retort underfeed, 3-2
  - Troubleshooting, 3-5
  - Types of, 3-1
- Summer lay-up
  - Cleaning, boiler 4-90
  - Draining, heating system, 4-89
  - Of cast iron boilers, 4-7, 4-90
  - Of controls and electrical connections, 4-97
  - Of gas burners, 4-93
  - Of oil burners, 4-92
  - Of pumps, 4-94
  - Of stack and breeching, 4-98
  - Of steam traps, 4-96
  - Of steel boilers, 4-90
  - Of stokers, 4-91
  - Of valves and strainers, 4-95
- Thermostats. See Automatic controls
- Unit heaters, gas-fired
  - Description of, 6-27
  - Installation of, 6-29
  - Introduction to, 6-26
  - Operation of, 6-28
- Unit heaters, steam
  - Description of, 4-55
  - Installation of, 4-56
  - Maintenance of, 4-57
  - Typical operating difficulties with, 4-58
- Warm-air heating systems. See also Furnaces
  - Air filters for, 6-37
  - Blower and limit control for, 6-39
  - Blower and motor maintenance with, 6-36
  - Ceiling delivery, 6-3
  - Central fan delivery, 6-3
  - Forced, 6-3
  - Gravity, 6-2
  - Humidifiers, 4-64, 4-65, 4-66
  - Inside wall delivery, 6-3
  - Outside wall delivery, 6-3
  - Perimeter delivery, 6-3
- Water level regulators
  - Description of, 4-31
  - Installation of, 4-32
  - Maintenance of, 4-34
  - Operation of, 4-33, 4-34
  - Servicing of, initial, 4-33
  - Typical operating difficulties with, 4-35

**The proponent agency of this publication is the Office of the Chief of Engineers, United States Army. Users are invited to send comments and suggested improvements on DA Form 2028 (Recommended Changes to Publications and Blank Forms) directly to Director, Engineering and Housing Support Center, ATTN: CEHSC-FU-M, Fort Belvoir, VA 22060-5516.**

By Order of the Secretary of the Army:

Official:

**THOMAS F. SIKORA**

*Brigadier General, United States Army*

*The Adjutant General*

**CARL E. VUONO**  
*General, United States Army*  
*Chief of Staff*

Distribution:

Army: To be distributed in accordance with DA Form 12-34B requirements for non-equipment technical manuals.

