



CAMP PENDLETON REQUIREMENTS NOVEMBER, 2012



Stephen H. Pitman, CDR, CEC, USN
Public Works Officer
MCB Camp Pendleton

8 NOV 2012

Date Signed

TABLE OF CONTENT

CAMP PENDLETON REQUIREMENTS

"ITALIC" FONT INDICATES REVISION TO PREVIOUS EDITIONS OF CPR.

DIVISION SECTION	CAMP PENDLETON REQUIREMENTS	PAGE
010000	LOCATION OF UNDERGROUND UTILITIES	5
011400	BUSINESS PASS AND RAPIDGATE	6
013300	SUBMITTAL DISTRIBUTION	7
<i>013300</i>	<i>SPECIFICATIONS FOR DIGITAL DATA</i>	10
<i>013500</i>	<i>RANGE SAFETY REQUIREMENTS</i>	13
017830	AS-BUILT DRAWINGS	14
018000	ADA ROOM REQUIREMENTS FOR BEQ	16
<i>018113</i>	<i>LEED ACCEPTABLE STRATEGIES/LEED-NC v2.2 AND LEED-NC v3.0</i>	16
<i>101426</i>	<i>BUILDING PLAQUE</i>	22
<i>142000</i>	<i>ELEVATOR CONSTRUCTION REQUIREMENTS</i>	22
<i>220101</i>	<i>UTILITY REQUIREMENTS</i>	26
<i>220519</i>	<i>BASE UTILITY METERS</i>	26
<i>220520</i>	<i>BASE INFORMATION SYSTEM ACCREDITATION</i>	30
<i>221110 & 221113</i>	<i>POTABLE WATER REQUIREMENTS</i>	31
221316	WASTE WATER REQUIREMENTS	41
221317	RECYCLED WATER	45

TABLE OF CONTENT CAMP PENDLETON REQUIREMENTS

230000	<i>GENERAL MECHANICAL REQUIREMENTS</i>	45
230515	<i>FOUR PIPE SYSTEM FOR NEW BEQ</i>	46
230900	<i>DIRECT DIGITAL CONTROL SYSTEMS</i>	48
231110	<i>ABOVEGROUND STORAGE TANKS</i>	48
234100	<i>NATURAL GAS REQUIREMENTS</i>	49
235200	<i>BOILER REQUIREMENTS</i>	52
235233	<i>LOW PRESSURE WATER HEATING BOILERS</i>	53
260400	<i>ELECTRICAL REQUIREMENTS</i>	56
263213	<i>DIESEL GENERATOR REQUIREMENTS</i>	64
271300 & 271500	<i>COX COMMUNICATIONS REQUIREMENTS</i>	64
271300 & 271500	<i>STRUCTURED TELECOMMUNICATIONS CABLING AND PATHWAY SYSTEM</i>	65
271400	<i>TELECOMMUNICATIONS BUILDING REQUIREMENTS</i>	75
275116 & 211313	<i>FIRE PROTECTION & SECURITY REQUIREMENTS FOR FIRE SPRINKLER AND MASS NOTIFICATION</i>	81
312100	<i>UTILITY TRENCH DETAIL</i>	86
334000	<i>STORMWATER</i>	86
334001	<i>STORMWATER DESIGN STANDARDS</i>	90
334002	<i>STORMWATER COLLECTION/CONVEYANCE SYSTEM</i>	91
334003	<i>GEOTECHNICAL CONSIDERATIONS FOR STORMWATER</i>	93

**TABLE OF CONTENT
CAMP PENDLETON REQUIREMENTS**

334004	<i>STORMWATER BEST MANAGEMENT PRACTICES (BMP)</i>	94
334005	<i>MANUFACTURED TREATMENT AND DETENTION BMPS</i>	98
334006	<i>WARRANTY, TESTING AND INSPECTION OF STORMWATER FACILITIES</i>	98
334007	<i>SPECIAL CONSIDERATIONS FOR STORMWATER</i>	99
334008	<i>BASE EXTERIOR ARCHITECTURE PLAN (BEAP) CONSIDERATIONS FOR STORMWATER BMPS</i>	102
REFERENCE STANDARDS	REFERENCE STANDARDS	104
POINT OF CONTACTS	CAMP PENDLETON POINT OF CONTACTS INFORMATION	106
APPENDIX	<i>BEAP ADDENDA</i>	107
	<i>MARINE CORP LOGO</i>	142
	<i>LANDSCAPE GUIDELINES</i>	143
	<i>INTERIOR DESIGN STANDARDS</i>	150
	<i>OMSI-OPERATION AND MAINTENANCE SUPPORT INFORMATION</i>	177
	<i>NCTD-PIPELINE CROSSING RAILWAY RIGHT-OF-WAY</i>	183
	<i>THREE MILE PIT</i>	192

CAMP PENDLETON REQUIREMENTS

(September 2012)

THE FOLLOWING CATEGORIES ARE BASED ON CSI 33 DIVISION SPECIFICATION ORGANIZATIONS. THEY CONTAIN DESIGN AND SPECIFICATION ISSUES THAT SHOULD BE ADDRESSED DURING THE PREPARATION OF CONSTRUCTION DOCUMENTS OR RFP'S FOR WORK AT MCB CAMP PENDLETON.

010000 LOCATION OF UNDERGROUND UTILITIES

SUMMARY OF WORK should be considered to cover such items such as location of underground utilities. Add Utility Coordination Report to Submittal paragraph. It should be annotated "G" for Government review.

1. Location of Underground Facilities/Utilities Scan the construction site with electromagnetic or sonic equipment, and mark the surface of the ground where existing underground utilities are discovered. Verify the elevations of existing piping, utilities, and any type of underground obstruction not indicated or specified to be removed but indicated [or discovered during scanning] in locations to be traversed by piping, ducts, and other work to be installed. Verify elevations before installing new work closer than nearest manhole or other structure at which an adjustment in grade can be made.
2. Coordination after contract award and prior to commencement of any clearing and grubbing, trenching, boring, earthwork, pile driving, or other operation that may damage underground utilities, the Contractor shall provide his own utility locator services. The Contractor shall review all available As-built Base Facility Drawing(s) for the area under construction. These drawings are located at the Facility Maintenance Office (Building 2296); telephone number (760) 725-3638. Request to review these drawings must be submitted to FMO, with a copy furnished to the Contracting Officer, at least fifteen working days in advance of the date when the Contractor desires to review these drawings. The Contractor shall coordinate the utility locating service with other applicable activities and agencies including but not limited to Camp Pendleton Base Communications (Building 2459), telephone number (760) 725-3101 and DIG ALERT at telephone number 1 (800) 422-4133.
3. Utility Location Coordination Report When utility location is furnished; the Contractor shall submit a report outlining the activities and agencies contacted. The DIG ALERT inquiry identification shall be provided in the report. No activity that could damage the underground utilities may begin until the Contracting Officer approves the coordination report.

BROKEN UTILITIES

1. Contractors shall be required to submit an Emergency Utility Repair Plan prior to being allowed to perform any excavation. Emergency shall be defined as the interruption of any and/or damage of any utility service. Including but not limited to the spill, or potential spill of any fuel oil, gas, potable water, sewage effluent, raw sewage, or storm water outside of system facilities.
2. The Emergency Utility Repair Plan shall include the following elements:
 - a. Equipment list of available pumps with sizes, excavation equipment, tools, and repair materials that are available onsite.
 - b. Labor force that will be available as a minimum to respond to emergencies.
 - c. Site-specific plan for locating, potholing, protecting, avoiding, and repairing any damage caused to existing, or newly installed utilities.

- d. Include the same level of detail for any subcontractors that will be performing work involving excavation.
 - e. Include a description of any planned effort that would involve bringing in subcontractor personnel to respond to emergencies.
 - f. The Plan shall be subject to approval by the Contracting Officer.
3. The Contractor shall demonstrate in his Emergency Utility Repair Plan that they are capable of responding to utility interruptions that could be caused by their construction operations or impacts from them. Immediately upon discovery of the situation, the Contractor shall react in a way that will minimize utility interruptions, releases, spills, impacts to utility customers, and potential for fines or notices of violations. In no case will repairs be left to be resolved the next day without the approval of the Contracting Officer.
4. The Contractor's Emergency Utility Repair Plan shall address the above items for each utility potentially impacted by construction, crossed by excavation, or known to be in the area but possessing properties that cause difficulties in identification of the exact location.
5. In the event that a utility is broken, all repairs affected will be the responsibility of the Contractor. The Contractor shall repair any damage to those facilities under the supervision of a Title 17 Distributor Operator, including those that are the property of a third party, resulting from failure to comply with the requirements of this contract or failure to exercise reasonable care in performing the work. If the Contractor fails or refuses to repair the damage promptly, the Contracting Officer may have the necessary work performed and charge the cost to the Contractor.

011400 BUSINESS PASS AND RAPIDGATE

Contractors must obtain a business pass or rapid gate depending on duration of expected work.

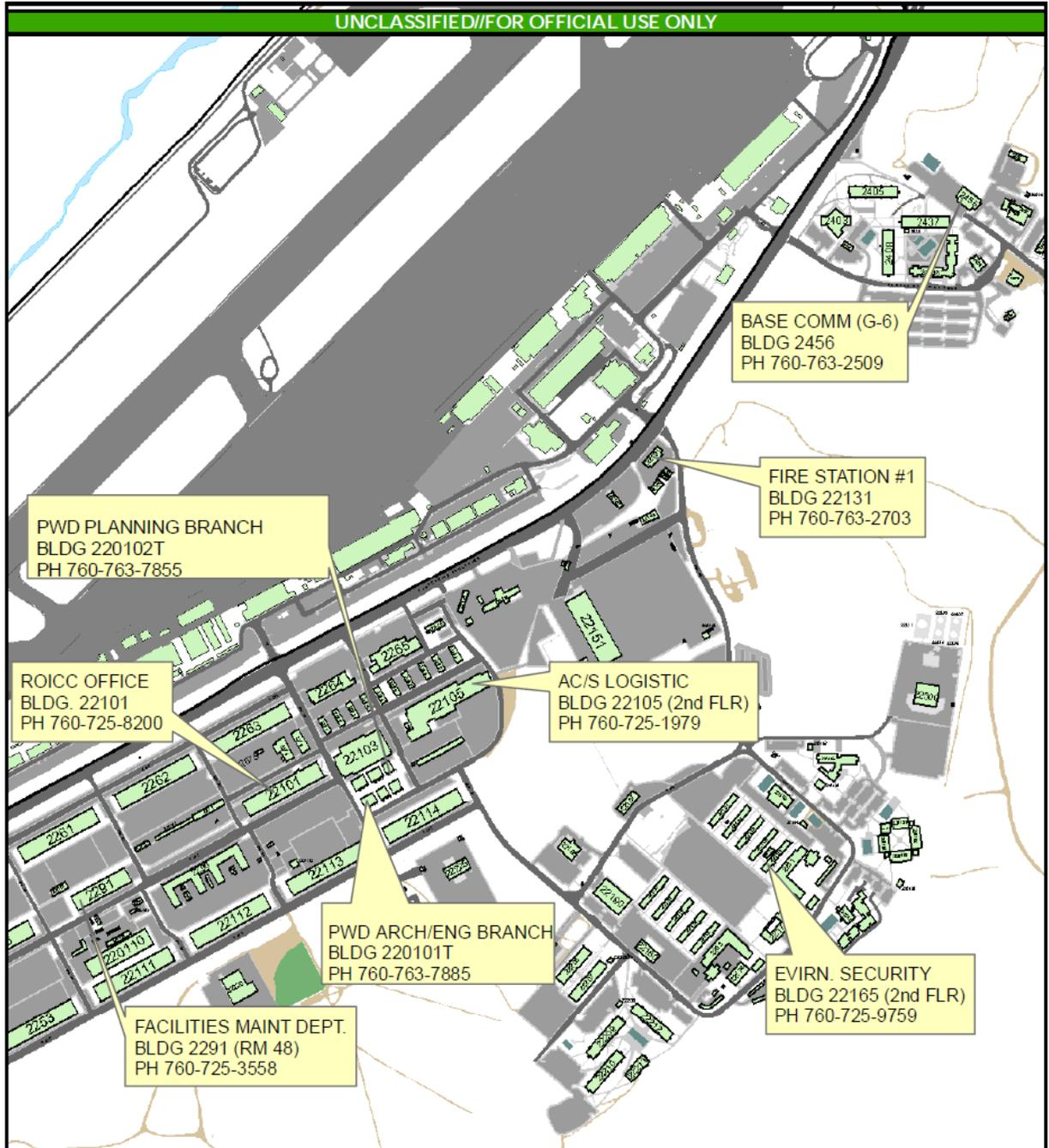
013300 SUBMITTAL DISTRIBUTION

1. Provide copies of each design submittal package for review to the following reviewers as Design Distribution List and Point of Contact Maps. Check with PWD project leader for this solicitation and proper distribution per project.

**BUILDING DESIGN SUBMITTAL DISTRIBUTION LIST
PUBLIC WORKS OFFICE, MCB, CAMP PENDLETON**

From:

THE FOLLOWING IS DISTRIBUTION LIST FOR THE DESIGN SUBMISSION FOR PWO CONCERNED OFFICE.		PHONE: FAX:	DATE:	
PROJECT NO.:	PROJECT TITLE AND LOCATION:		TYPE OF REVIEW: UP TO 100% SUBMITTAL & FINAL SUBMITTAL	
DISTRIBUTION		DESIGN SUBMITTAL FORMAT	UP TO 100%	FINAL
TO: PWD: Project Leader AC/S Facilities, PWD Arch/Eng Branch Bldg.220101T, Camp Pendleton, CA, 92055		½ Size- DRAWINGS CD- AUTOCAD and PDF drawings CD- PDF with Bookmark of SPECIFICATIONS, REPORTS, ELECTRONIC MEDIA, STORM WATER DESIGN, ALL OTHERS	4 SETS	2 SETS
TO: Tony Ray PWD: Planning Director AC/S Facilities, PWD Planning Branch Bldg. 220102T, Camp Pendleton, CA, 92055		½ Size DRAWINGS CD- PDF with Bookmark of SPECIFICATIONS	1 SET	1 SET
TO : Monique Ramirez AC/S Billeting (For BEQ project only) Bldg.1341, Camp Pendleton, CA, 92055		½ Size DRAWINGS CD- PDF with Bookmark of SPECIFICATIONS	1 SET	1 SET
TO: Respective Area S-4 (or Camp Services) List to be provided by Project Leader		½ Size DRAWINGS CD- PDF with Bookmark of SPECIFICATIONS	1 SET	1 SET
TO: Ernest Grant FMD: Facilities Mgmt Specialist/Liason Office Bldg. 2291, Camp Pendleton, CA, 92055		½ Size DRAWINGS CD- PDF with Bookmark of SPECIFICATIONS	1 SET	-
TO: Chief Robert Johnson Fire Station: Chief Bldg.22131 (2 nd Flr), Camp Pendleton, CA 92055		½ Size DRAWINGS CD- PDF with Bookmark of SPECIFICATIONS	1 SET	1 SET
TO: Paul Lane or Michael Peterson MCI West G-6: Engineering Draftsman/GIS Analyst Bldg.2456, Camp Pendleton, CA. 92055		½ Size DRAWINGS CD- PDF with Bookmark of SPECIFICATIONS	1 SET	-
TO: AC/S Logistic: CMSC Bldg.22105 (2 nd Flr), Camp Pendleton, CA, 92055		FF&E Preliminary and Final Binder	1 SET	1 SET
TO: John Burke Environmental Security: NEPA Branch Head Bldg. 22165 (2 nd Flr) Camp Pendleton, CA, 92055		½ Size DRAWINGS CD- PDF with Bookmark of SPECIFICATIONS	-	1 SET
TO: ROICC Construction Manager ROICC Office, Bldg. 22101 Camp Pendleton, CA, 92055		½ Size- DRAWINGS CD- AUTOCAD and PDF drawings CD- PDF with Bookmark of SPECIFICATIONS, REPORTS, ELECTRONIC MEDIA, ALL OTHERS	3 SETS	3 SETS
TO: Larry E. Boyd Provost Marshals Office (PMO) Bldg. 1523 Camp Pendleton, CA. 92055 PMO will coordinate with SPAWAR		1/2 size drawings CD - PDF and AutoCad	CD only up until 50 % CD plus drawings after 50%	1 SET



MARINE CORPS BASE CAMP PENDLETON

MCB Camp Pendleton
Beven Harris, IG&S Manager
Phone: 760.263.3835
Email: beven.harris@usmc.mil
Intranet: https://po.gpoifwost.usmc.mil
Map Published 4/25/2012, BENSONGW

UNCLASSIFIED//FOR OFFICIAL USE ONLY

ALTHOUGH EVERY EFFORT HAS BEEN MADE TO ENSURE THE ACCURACY OF THE INFORMATION, ERRORS AND CONDITIONS DERIVING FROM PHYSICAL SOURCES TO DEVELOP THE DATABASE MAY BE REFLECTED IN THE DATA SUPPLIED. THE USER MUST BE AWARE OF DATA CONDITIONS AND ULTIMATELY BEAR RESPONSIBILITY FOR THE APPROPRIATE USE OF THE INFORMATION WITH RESPECT TO POSSIBLE ERRORS, ORIGINAL MAP SCALE, COLLECTION METHODOLOGY, CURRENTCY OF THE DATABASE AND OTHER CONDITIONS SPECIFIC TO CERTAIN DATA. THIS INFORMATION DOES NOT DEPICT ALL POSSIBLE RESOURCES. FIELD VERIFICATION OF ALL DATA IS REQUIRED FOR SITE SPECIFIC PROJECTS. THIS INFORMATION IS DEEMED RELIABLE BUT NOT GUARANTEED.




SCALE 1:9,000

0 250 500 750 1,000 Feet
0 0.05 0.1 0.15 0.2 Miles
0 75 150 225 300 Meters

ELLIPSOID: GEODETIC REFERENCE SYSTEM 1980
PROJECTION: CASTRE PLANE ZONE W
HORIZONTAL DATUM: NAD 83/WGS 1984

NAD 83/WGS 84

THE NORTH AMERICAN DATUM 1983 (NAD83) AND THE WORLD GEODETIC SYSTEM 1984 DATUM (WGS 1984) ARE EQUIVALENT FOR MAPPING, CHARTING AND NAVIGATION AT THIS SCALE.



013300 SPECIFICATIONS for DIGITAL DATA

Any maps, drawings, figures, sketches, geospatial data, spreadsheets, or text files prepared for this contract shall be provided in both hard copy and digital form. The hard copy deliverables are defined in another section of this SOW.

Text, Spreadsheet, and Database Files:

1. The Marine Corps standard computing software is Microsoft Office 2007. Final Reports and other text documents shall be provided in Microsoft Word 2007 format AND Adobe Portable Document Format (PDF). Spreadsheet files shall be provided in Microsoft Excel 2007 format. Databases shall be provided in Microsoft Access format, unless specified otherwise, as approved by the Government. Prior to database development, the Contractor shall provide the Government with a Technical Approach Document for approval, which describes the Contractor's technical approach to designing and developing the database. All text, spreadsheet, and database files shall be delivered on a Compact Disk read-only memory (CD-ROM), Digital Versatile Disc read-only memory (DVD-ROM) or portable external hard drive.

Maps, Drawings, and Sketches (Digital Geospatial Data):

1. Geospatial Data Software Format:

Geographic data must be provided in a form that does not require translation, preprocessing, or post processing before being loaded to the Installation's regionally hosted geodatabase. The Contractor shall validate any deviation from this specification in writing with the Government (Installation Geospatial Information & Services (IGI&S) Manager via the Project Manager). Digital geographic maps and the related data sets shall be delivered in the following software format:

- a. **CADD:** All CADD data shall be provided in AutoCAD 2004 and shall be in the same projection and use the same coordinate system, datum, and units as stated below in the paragraph titled Geospatial Data Projection. Drawing files shall be full files, uncompressed, unzipped, and georeferenced.

-AND-

- b. **GIS:** If the Subject Project is MILCON and/or utility project. Personal or file geodatabase format using ArcGIS 9.3. The geodatabase must be importable to a multi-user geodatabase using ArcSDE 9.3. The delivered data layer(s) shall be provided with x,y domain precision of 1000.

(NOTE: ArcGIS and ArcSDE are geographic information system software produced by the Environmental Systems Research Institute (ESRI) of Redlands, California. AutoCAD is software produced by Autodesk, Inc.)

2. Geospatial Data Structure:

- a. **GIS Data Sets:** When developing/delivering geospatial data, the Contractor shall develop the initial structure consistent with the most current version of the **Camp Pendleton** Data Model. The **Camp Pendleton** Data Model shall be followed for geospatial database table structure, nomenclature, and attributes. The Government may approve modifications to the **Camp Pendleton** Data Model if it is determined that the **Camp Pendleton** Data Model does not adequately address subject datasets. Copies of the **Camp Pendleton** Data Model may be obtained by contacting the Camp Pendleton GIS Office via phone at Phone 1-760-763-1891.

-AND / OR-

- b. **CADD Drawings/Data:** The Contractor shall develop all CADD data in conformance with the latest version of the following standards and policies:
 - U. S. National CADD Standards (NCS)
 - CADD/GIS Technology Center's AEC CADD Standards (<https://tsc.wes.army.mil>)
 - NAVFACINST 4250.1, Electronic Bid Solicitation

3. Geospatial Data Projection:

- a. Geographic data (regardless of format) shall be provided in U.S. Survey Feet and **projected** into the California State Plane, Zone VI, FIPS 0406 projection system. The maps and data shall use the GRS 1980 spheroid and the North American Datum 1983/World Geodetic System 1984 (NAD83/WGS84). Epoch 1991.35 shall be used the vertical datum used is NAVD88. This projection requirement applies to all GIS data layer deliverables as well as all CADD drawings such as as-designed and as-built project plans. Each data set shall have a projection file if appropriate based on format.

4. Geospatial Data Collection:

- a. **Survey grade Global Positioning System (GPS)** data collection shall be performed when specified in the statement of work or if the Subject Project is a MILCON and/or utility project. Survey grade GPS data collection shall at a minimum use the Geoid2003 CONUS epoch and spatial accuracy requirements for survey grade are 95 % of GPS points are within ± 6 centimeter. Every effort shall be made to capture feature locations without using offsets unless obstructions are present.
- b. *All final* GPS data collection activities shall be logged with the MCB Camp Pendleton GIS Office prior to initiation (*temporary benchmarks set up for site work do not need to be logged*). GPS data collection shall tie into the MCB Camp Pendleton GPS Base Station. Checks shall be made to existing Survey Control Monuments around the area of work (Control Coordinates, Maps & Monument Record Sheets are available from the GIS Office). All checks made to control points must be recorded and discrepancies noted in the deliverables. Data collected but not verified via this method will not be accepted for submittal.

5. Map Products and Support Files:

Finished map products, regardless of final print size, shall be presented separately in both hard copy and digital formats. The hard copy deliverables are defined in another section of this SOW. Final map products shall be delivered in the following digital formats:

- a. PDF Format: Resolution of 300 dpi with no image compression. All fonts must be embedded. The Contractor shall only use fonts that are licensed and available for use by the Government.
- b. JPG (Joint Photographic Experts Group) Format: Resolution of 96 dpi with 24-bit true color.
- c. MXD (ESRI Map Document) Format: All maps constructed shall have the associated MXD delivered to allow for future printing and modification, as necessary, by the Government. MXDs shall use the 'relative paths' option. The Table of Contents (TOC) within the MXD shall be orderly, and contain a logical naming structure.

6. Geographic Data Documentation (Metadata):

For each digital file delivered containing geographic information (regardless of format), the Contractor shall provide documentation consistent with the GEOFidelis Metadata Guidelines, which follow Federal Geographic Data Committee (FGDC) Content Standards for Digital Geospatial Metadata (CSDGM). Both 'Mandatory' and 'Mandatory as Applicable' fields shall be completed for each geographic data set, as well as selected 'Optional' fields. The documentation shall include, but not be limited to, the following:

- a. The name, description, abstract, and purpose of the data set/data layer.
- b. The source of the data and any related data quality information such as accuracy and time period of content.
- c. Descriptions of the receiver and other equipment used during collection and processing, base stations used for differential corrections, software used for performing differential corrections, estimated horizontal and vertical accuracies obtained, and conversion routines used to translate the data into final geographic data delivery format.
- d. Details of all checks made to existing control points & any discrepancies noted.
- e. Type of data layer (point, line, polygon, etc.).
- f. Field names of all attribute data and a description of each field name.
- g. Definition of all codes used in the data fields.
- h. Ranges of numeric fields and the meaning of these numeric ranges.
- i. The creation date of the map layer and the name of the person who created it.
- j. A point of contact shall be provided to answer technical questions.

Metadata generation tools included in the ArcGIS suite of software (or equivalent technology) shall be used in the production of the required metadata in XML format. Regardless of the tools used for metadata creation, the Contractor must insure that the metadata is delivered in XML format. Specific guidelines may be found within the GEOFidelis West Metadata Authoring Guide. A copy of the guide may be obtained by contacting:

GEOFidelis West
Building 1160, Lower Level Room 6
Camp Pendleton, CA 92055
(760) 763-1891

(NOTE: The metadata should be formatted from the Installation database perspective, not the Contractor project perspective. Therefore such items as Point of Contact should be the Installation POC currently associated with the data and NOT the Contractor's Project Manager. The Contractor shall use language and format consistent with existing Installation metadata.)

7. Geographic Data Review:

The digital geographic maps, related data, and text documents shall be included for review in the draft and final contract submittals. The data will be analyzed for discrepancies in subject content, correct format in accordance with these specifications, and compatibility with the existing GIS system. The Contractor shall incorporate review comments to data and text prior to approval of the final submittal.

8. Ownership:

All digital files, final hard copy products, source data acquired for this project, and related materials, including that furnished by the Government, shall become the property of the Installation and will not be issued, distributed, or published by the Contractor.

013500 RANGE SAFETY REQUIREMENTS

RANGE SAFETY REQUIREMENTS FOR ENTERING A TRAINING AREA OR RANGE

1. In order for the Contractor to work on a Range or in a Training Area, they shall have a certified Administrative Range Safety Officer (RSO) on-site whenever the site is occupied. The contractor shall do the following in order to obtain certification as a RSO and gain access to the site:
 - a. The person in charge of the site or another competent person that will be on site must pass a written examination. The test is based on information that is presented in the remote RSO Class on-line at:
<https://pendleton.mciwest.nmci.usmc.mil/ot/rod/default.aspx>. For persons that can only access the Base web site, watch the remote RSO Class on line at:
<http://www.pendleton.usmc.mil/base/oandt/rod/index.asp>.
Names of persons who successfully passed the written test will be posted on the RSO Roster on the Wednesday following the day of the test. The RSO Roster can be viewed at <https://pendleton.mciwest.nmci.usmc.mil/ot/rod/default.aspx>. If you do not have access to this site please call (760) 725-0357 or e-mail: PNDL_OTRANGEINSPECTORS@usmc.mil
 - b. Schedule the Range or Training Area (RTA) through their Base sponsor. Please allow a minimum of 30 calendar days to schedule a RTA.
 - c. Obtain a Camp Pendleton 1:50,000 Military Installation Map from your Base sponsor.
 - d. Obtain a radio compatible with the Range Operations Division (ROD) communication system. Obtain the radio from your Base sponsor.
 - e. Maintain a copy of a letter from the RSO's company that names the RSO as a competent and knowledgeable person of the activities taking place on/in the RTAs of Camp Pendleton. A copy of the letter should be kept with the RSO and at the job site. The letter shall be on company letterhead signed by an officer of the company.
 - f. Gain positive communication prior to entering the RTA and maintain positive communication while in the RTA. Follow the directions of Range Control while in the RTA.
2. The written test is administrated on the third Thursday of each month. Testing takes place in the first floor classroom of Building 2399. There are three testing sessions, occurring at 08:00, 09:30 and 11:00. Testing is by appointment only. To obtain an appointment, e-mail PNDL_OTRANGEINSPECTORS@USMC.mil or call (760) 725-0357, (760) 725-3510, or (760) 725-4219. Class handout and "bubble sheet" can be obtained at the following web site: <https://pendleton.mciwest.nmci.usmc.mil/ot/rod/default.aspx> or <HTTP://www.pendleton.usmc.mil/base/Oandt/rod/index.asp>. The hand out and bubble sheet **will not** be provided at the test session. Test attendees shall bring, to the class, picture ID, Base sponsor information (name of point of contact and Base unit name), pen or pencil.
3. Prior to entering any RTA site, **the contractor and Base sponsor** will ensure all areas requiring access have been properly scheduled and approved for the dates and times needed. Failure to schedule these areas through ROD will result in access being denied from Range Control (LONGRIFLE) until proper scheduling of events has been completed. **Contractor shall schedule the site through their Base sponsor.**
4. The contractor and their employees shall not deviate from the assigned access route or the work site unless directed by Longrifle or other ROD official.

5. *For non-company vehicles, the contractor shall obtain Privately Owned Vehicle (POV) placards from ROD. Placards will be issued only for truck type four-wheel drive vehicles. These placards shall be placed in the front window of each POV whenever the vehicle is in a training area and/or on a range. To obtain a placard the contractor must provide the name of the driver of each vehicle; the year; make, and model of the vehicle; color; and license plate number. The amount of parking available at the project site may be limited for operational and safety reasons.*

017830 AS-BUILT DRAWINGS

GENERAL DESIGN CONSIDERATIONS

The use of Section 017830 – CLOSEOUT SUBMITTALS should be considered to cover such items such as as-built drawings and stormwater closeout submittals.

Division 01 – GENERAL REQUIREMENTS

1.2.1 As-Built Drawings

1.2.1.1 In addition to the requirements of FAC 5252.236-9310, the Contractor shall be responsible for all of the following requirements.

- a. Redlining - Notations are to be performed using the following color coding schemes:
 1. Red - Indicates additions or corrections.
 2. Green - Indicates deletions.
 3. Yellow - Indicates correct information.
 4. Blue/Black - Indicates information that may be helpful during incorporation of the mark-ups.
- b. The contractor shall transform the redline drawings into record documents. The final record drawings shall be stamped and signed by a registered Architect or Engineer with formatting in accordance with the UFC 1-300-09N Design Procedures.
- c. The final record drawings shall be turned over to the government at the pre-final inspection. Provide the government the following:
 1. Provide additional sheets that contain all underground utilities. Provide 1 full size utilities sheet covered with plastic laminate.
 2. Provide electronic copies in AutoCAD 2004 and Adobe PDF format, latest version.
 3. Provide 4 Complete sets on CD-ROM.
 4. Provide 1 set of redline drawings.
 5. Provide cost data on the final cost of the project using table at end of this specification section.
- d. Record Drawing Format: In addition to other record drawing document format requirements provide for the following:

DD Form 1354, transfer and acceptance of Real Property.

1. NAVFACSW PM is responsible to ensure the AE or in-house designers work includes DD Form 1354 deliverables at:
 - a. Draft DD Form 1354 at 100% design
 - b. Interim DD Form 1354 at BOD
2. NAVFACSW DM is responsible to assist the DOR in preparation of the Draft DD 1354 at 100% design and providing a copy to the Real Property Asset Officer (RPAO)
3. NAVFACSW ROICC CM, during the Post Award Kickoff or Pre-Construction Conference, is to lay out expectations for DD Form 1354 deliverables at:

- a. Draft DD Form 1354 at 100% design
- b. Interim DD Form 1354 at BOD
- 4. CM, during the Red Zone Meetings, and at least 60 days prior to BOD, is to remind the construction contractor of requirements to provide the cost breakout per asset at least 30 days prior to BOD.
- 5. CM, 30 days prior to BOD, is to receive the Interim DD Form 1354 from the Contractor, review it and adjust for any modifications, and forward it to the RPAO with a copy to the PM.

The design team should be driving the Draft DD Form 1354, for delivery to the RPAO at the 100% design submittal. If it's missing, please push the DM to provide it. Per the contract, the Interim DD Form 1354 shall be submitted by the contractors at least 30 days prior to BOD. The NAVFAC SW PM is responsible for providing the Final DD Form 1354 to the RPAO when the contract is financially complete.

UFC 1-300-08 16 Apr 09 Change 1, Mar 10

TRANSFER AND ACCEPTANCE OF DoD REAL PROPERTY													Form Approved OMB No. 0704-0188		
													PAGE	OF	PAGES
The public reporting burden for this collection of information is estimated to average 30 minutes per response, including the time for reviewing instructions, searching existing data sources, gathering and maintaining the data needed, and completing and reviewing the collection of information. Send comments regarding this burden estimate or any other aspect of this collection of information, including suggestions for reducing the burden, to the Department of Defense, Washington Headquarters Service, Executive Service Directorate, Information Management Division, 1215 Defense Postage, Washington, DC 20304-1155 (0704-0188). Respondents should be aware that notwithstanding any other provision of law, no person shall be subject to any penalty for failing to comply with a collection of information if it does not display a currently valid OMB control number.															
PLEASE DO NOT RETURN YOUR COMPLETED FORM TO THE ABOVE ORGANIZATION.															
1. FROM (Organization Name)			2. DATE PREPARED (YYYYMMDD)		3. PROJECT/JOB NUMBER		4. SERIAL NUMBER		8. TRANSACTION DETAILS						
5. TO (Organization - Installation Code and Name)			6. RPSUID/SITENAME/INSTCODE/INSTNAME		7. CONTRACT NUMBER(S)		7a. PLACED-IN-SERVICE DATE (YYYYMMDD)		a. METHOD (X all that apply) <input type="checkbox"/> ACQUISITION BY CONSTRUCTION <input type="checkbox"/> TRANSFER BETWEEN SERVICES <input type="checkbox"/> CAPITAL IMPROVEMENT <input type="checkbox"/> INVENTORY ADJUSTMENT			b. WHEN/EVENT (X one) <input type="checkbox"/> TOTAL ASSET PLACED-IN-SERVICE <input type="checkbox"/> PARTIAL ASSET PLACED-IN-SERVICE			
									c. TYPE (X one)						
									<input type="checkbox"/> DRAFT			<input type="checkbox"/> FINAL		<input type="checkbox"/> INTERIM	
9. ITEM NO.	10a. FACILITY NO.	10b. RPUID	11. CATEGORY CODE	12. CATCODE DESCRIPTION	13. TYPE CODE	AREA		OTHER		18. COST	19. FUND SOURCE	20. FUND ORG	21. INTER-EST CODE	22. ITEM REMARKS	
						14. PRIMARY UM	15. PRIMARY UM QUANTITY	16. SECONDARY UM	17. SECONDARY UM QUANTITY						
23. STATEMENT OF COMPLETION. The facilities listed hereon are in accordance with maps, drawings, and specifications and change orders approved by the authorized representative of the using agency except for the deficiencies listed on the reverse side.										24.a. ACCEPTED BY (Typed Name and Signature)			b. DATE SIGNED (YYYYMMDD)		
a. TRANSFERRED BY (Typed Name and Signature)					b. DATE SIGNED (YYYYMMDD)					c. TITLE (DPW/RPAO)			25. PROPERTY VOUCHER NUMBER		
c. TITLE (Area Engr./Base Engr./DPW/Construction Agent)															

DD FORM 1354, SEP 2009

PREVIOUS EDITION IS OBSOLETE.

(Add'l Ed/Issued) 5 0

26. CONSTRUCTION DEFICIENCIES (Attach blank sheet for continuations)	27. PROJECT REMARKS (Attach blank sheet for continuations)
<p style="text-align: center;">INSTRUCTIONS</p> <p>GENERAL. This form has been designed and issued for use in connection with the transfer of military real property between the military departments and to or from other government agencies. It supersedes ENG Forms 290 and 290B (formerly used by the Army and Air Force) and NAVDOCKS Form 2317 (formerly used by the Navy). Existing instructions issued by the military departments relative to the preparation of DD Form 1354 are applicable to this revised form to the extent that the various items and columns on the superseded forms have been retained. The military departments may promulgate additional instructions, as appropriate.</p> <p>For detailed instructions on how to fill out this form, please refer to Unified Facilities Criteria (UFC) 1-300-08, dated 16 April 2009 or later.</p> <p>SPECIFIC DATA ITEMS.</p> <ol style="list-style-type: none"> From. Name of the transferring agency. Date Prepared. Date of actual preparation. Enter all dates in YYYYMMDD format (Example: March 31, 2010 = 20100331). Project/Job Number. Project number on a DD Form 1391 or Individual Job Order Number. Serial Number. Sequential serial number assigned by the preparing organization (e.g., 2010-0001). To. Name and address of the receiving installation, activity, and Service of the Real Property Accountable Officer (RPAO). RPSUID/SITENAME/INSTCODE/INSTNAME. Real Property Site Unique Identifier and Site Name or Installation Code and Installation Name where the constructed facility is located. Contract Number(s). Contract number(s) for this project. Placed-In-Service Date. RPA Placed In Service Date. This is the date the asset is actually placed-in-service. Transaction Details. <ol style="list-style-type: none"> Method of Transaction. Mark (X) as many boxes as apply. When/Event. When or event causing preparation of DD Form 1354. X only one box. Type. Draft, interim, or final DD Form 1354. X only one box. Item Number. Use a separate item number for each facility, no item number for additional usages. 10a. Facility Number. Assigned in accordance with the Installation/Base Master Numbering Plan. 10b. RPUID. Real Property Unique Identifier - Identified in Real Property Inventory. 11. Category Code. The category code describes the facility usage. 12. Catcode Description. The category code name which describes the facility usage. 13. Type Code. Construction Type Code - Type of construction: P for Permanent; S for Semi-permanent; T for Temporary. 14. Primary Unit Of Measure. Area unit of measure; use the unit of measure associated with the category code selected in 11. 15. Primary Unit of Measure Quantity. The total area for the measure identified in Item 14. Use negative numbers for demolition. 16. Secondary Unit of Measure. Unit of Measure 2 is the capacity or other measurement unit (e.g., LF, MB, EA, etc.). 17. Secondary Unit of Measure Quantity. The total capacity/other for the measure identified in Item 16. 18. Cost. Cost for each facility; for capital improvements to existing facilities, show amount of increase only. If there is no increase for the capital improvement, enter N/A. Fund Source. Enter the Fund Source Code for this item. Funding Organization. Enter the code for the organization responsible for acquiring this facility. Interest Code. RPA Interest Type Code. Enter the code that reflects government interest or ownership in the facility. Item Remarks. Remarks pertaining only to the item number identified in Item 9; show cost sharing. Statement of Completion. Typed name, signature, title, and date of signature by the responsible transferring individual or agent. Accepted By. Typed name, signature, title, and date of signature by the RPAO or accepting official. Property Voucher Number. Next sequential number assigned by the RPAO in voucher register. Construction Deficiencies. List construction deficiencies in project during contractor turnover inspection. Project Remarks. Project level remarks and continuation of blocks. 	

DD FORM 1354 (BACK), SEP 2009

Reset

018000 ADA ROOM REQUIREMENTS FOR BEQ

- The Two (2) ADA Compliant Rooms required for a typical BEQ, whether new construction or major renovation should be located close to ADA Parking and/or Duty Desk.

018113 LEED ACCEPTABLE STRATEGIES

Due to functional constraints at MCB Camp Pendleton the following LEED points should be carefully considered:

PI Form 1: Minimum Program Requirements

#7. Must comply with a minimum Building to Site Ratio

The Base does not have set "property lines", so the determination of the "2% of gross land area" becomes difficult. Per the Base Master Plan 1.1.1 "Basewide Master Planning Vision", all projects must "Optimize land use allocation and facility siting by developing a logical and functional land use plan that maximizes real estate use for training; reduces building footprints; improves efficiency; promotes land use compatibility; and permits future expansion."

EA Credit 2: On-Site Renewable Energy

This credit can be obtained, and is encouraged, through the installation of renewable energy systems.

MCB CP must retain REC's (renewable energy certificates) to comply with renewable energy mandates. Per HQMC this Base is not allowed to purchase REC's to meet energy mandates.

The following points cannot be supported by MCB CP, and should not be included in potential project scorecards:

IEQ Credit 7.2: Thermal Comfort – Verification

The Base will not be conducting “thermal comfort surveys” after project occupancy.

SS Credit 5.2: Site Development – Maximize Open Space

Again, per the Base Master Plan 1.1.1 “Basewide Master Planning Vision”, all projects must “Optimize land use allocation and facility siting by developing a logical and functional land use plan that maximizes real estate use for training; reduces building footprints; improves efficiency; promotes land use compatibility; and permits future expansion.” However, the requirement that “All open space that is counted toward this credit will be preserved for the life of the building” cannot be guaranteed “forever”.

LEED-NC 2.2 (per HQMC Order maximum LEED level desired is silver)

1. Below is a chart of **LEED-NC v2.2** credits mandated by NAVFAC with acceptable strategies for implementing those credits at MCB Camp Pendleton
2. Following the chart is a list of acceptable strategies for **LEED-NC v2.2** credits not mandated by NAVFAC, but preferred by the Base.

LEED-NC 2.2 NAVFAC Mandated Credits		Pts	Acceptable Strategies for use at MCB Camp Pendleton
SUSTAINABLE SITES			
SS6.1	Storm Water Design – Quantity Control	1	Comply with: Calif. Gen. Constr. Storm Water Permit Effective 1 July 2010, EISA 2007 (Energy Independence & Security Act). Comply with Dept. of Navy LID (Low Impact Development) Policy and Unified Facilities Criteria (UFC) 3-210-10, effective 1 Oct 2010 Reference CPR Stormwater Section for strategies.
SS6.2	Storm Water Design Quality Control	1	Comply with: Calif. Gen. Constr. Storm Water Permit Effective 1 July 2010. Comply with Dept. of Navy LID (Low Impact Development) Policy and Unified Facilities Criteria (UFC) 3-210-10, effective 1 Oct 2010 Reference CPR Stormwater Section for strategies.
WATER EFFICIENCY			
WE 1.1	Water Efficient Landscaping, Reduce by 50%	1	Passive captured rain water is acceptable (i.e. divert rain from downspouts to irrigate landscape) Use of recycled waste water from Tertiary Treatment plants/purple pipe desired

			Grey water systems not allowed
WE 3.1	Water Use Reduction 20%	1	Waterless urinals not approved for use at MCB Camp Pendleton
ENERGY AND ATMOSPHERE			
EA Prereq	Fundamental Commissioning	0	Discretionary*
EA1	Optimize Energy Performance	1-10	Daylight sensors are desired for large spaces such as warehouses, hangers, storage buildings and mechanical buildings. The use of light shelf/clerestory window design is desirable. Daylight sensors are not desired for BEQ or Administration Buildings. If boilers are used, the best technology <i>fire tube/firebox</i> type available should be utilized. Separate hot water boilers from HVAC boilers so that each system can function independently from the other.
EA 4	Enhanced Refrigerant Mgt	1	Discretionary*
EA 5	Measurement and Verification	1	Executive Order 13423
MATERIALS AND RESOURCES			
MR 2.1	Construction Waste Mgt.	1	Discretionary*
MR 4.1	Recycled Content 20%	1	Discretionary*
MR 6	Rapidly Renewable Products	1	Discretionary*
MR 7	Certified Wood	1	Discretionary*
INDOOR ENVIRONMENTAL QUALITY			
EQ 4	Low Emitting Materials	1	Executive Order 13423 and 13514
EQ 7.1	Thermal Comfort Design	1	DDC Controls required for main HVAC design, but not desirable in individual BEQ Living Units.
EQ 8.1	Daylighting	1	
INNOVATION AND DESIGN			
ID	Moisture Control Plan	1	Discretionary*
ID	Bio-Based Products	1	Executive Order 13423
ID	LEED AP	1	Discretionary*

*To be determined on a case by case basis.

Additional Acceptable Strategies for optional LEED-NC v2.2 credits at MCB Camp Pendleton:

SS 4.3 Alternative Transportation/Low Emitting & Fuel Efficient Vehicles:
 -Electric car ports desirable/Executive Order 13514.
 -SWRFT Office manages Base vehicles at MCB Camp Pendleton

EA Prereq 2: Minimum Energy Performance:

- Use VAC or VAV mechanical systems if technology complies with CPR (Camp Pendleton Requirements). VRV systems are not allowed.
- Use of re-heat systems desirable
- Geothermal energy should not be explored. Base studies have proven the ground water does not support the required temperature needed for geothermal energy design.

- EA 2 On-Site Renewable Energy
Utilize photovoltaic solar panels for all FY12 projects and FY10 M2R2 Projects.
- EA3 Enhanced Commissioning
-Enhanced commissioning is desired of all HVAC systems and controls, refrigeration systems and controls, renewable energy systems and hot water systems. Enhanced commissioning is to be provided by third party. TAB contractor is not permitted to perform the enhanced commissioning. Return of Contractor after completion of project to implement Enhanced Commissioning to be enforced; enhanced commissioning to be under a separate contract from building.
- EA6 Green Power
-NAVFAC does not allow.
- EQ1 Outdoor Air Delivery Monitoring
-Desirable on all buildings. Must interface with MCB Camp Pendleton EMS (Energy Management System).

LEED-NC v3

1. Below is a chart of **LEED-NC v3** credits mandated by NAVFAC with acceptable strategies for implementing those credits at MCB Camp Pendleton
2. Following the chart is a list of acceptable strategies for **LEED-NC v3** credits not mandated by NAVFAC, but *preferred* by the Base.

LEED-NC v3 NAVFAC Mandated Credits		Pts	Acceptable Strategies for use at MCB Camp Pendleton
SUSTAINABLE SITES			
SS6.1	Storm Water Design – Quantity Control	1	Comply with: Calif. Gen. Constr. Storm Water Permit Effective 1 July 2010, EISA 2007 (Energy Independence & Security Act). Comply with Dept. of Navy LID (Low Impact Development) Policy and Unified Facilities Criteria (UFC) 3-210-10, effective 1 Oct 2010 Reference CPR Stormwater Section for strategies.
SS6.1			
SS6.2	Storm Water Design Quality Control	1	Comply with: Calif. Gen. Constr. Storm Water Permit Effective 1 July 2010. Comply with Dept. of Navy LID (Low Impact Development) Policy and Unified Facilities Criteria (UFC) 3-210-10, effective 1 Oct 2010 <i>Reference CPR Stormwater Section for strategies.</i>
WATER EFFICIENCY			
WE	Water Use Reduction	0	Waterless urinals not approved for use at

Prereq	by 20%		MCB Camp Pendleton
WE 1.1	Water Efficient Landscaping, Reduce by 50%	2-4 1	Passive captured rain water is acceptable (i.e. divert rain from downspouts to irrigate landscape) Use of recycled waste water from Tertiary Treatment plants/purple pipe desired Grey water systems not allowed Additional Point – Regional Priority Credit
ENERGY AND ATMOSPHERE			
EA1	Optimize Energy Performance	1-19	Daylight sensors are desired for large spaces such as warehouses, hangers, storage buildings and mechanical buildings. The use of light shelf and clerestory window design is desirable. Daylight sensors are not desired for BEQ or Administration Buildings. If boilers are used, the best technology <i>fire tube/firebox</i> type available should be utilized. Separate hot water boilers from HVAC boilers so that each system can function independent from the other.
EA 4	Enhanced Refrigerant Mgt	2	Discretionary*
EA 5	Measurement and Verification	3	Executive Order 13423
MATERIALS AND RESOURCES			
MR 2.1	Construction Waste Mgt.	1-2	Discretionary*
MR 4.1	Recycled Content 20%	2	Discretionary*
MR 6	Rapidly Renewable Products	1	Discretionary*
MR 7	Certified Wood	1	Discretionary*
INDOOR ENVIRONMENTAL QUALITY			
EQ 3.1	Construction IAQ Mgt During Construction	1	Discretionary*
EQ 3.2	Construction IAQ Mgt Before Occupancy	1	Discretionary*
EQ 4	Low Emitting Materials	1-4	Executive Order 13423 and 13514
EQ 7.1	Thermal Comfort Design	1	DDC Controls required for main HVAC design, but not desirable in individual BEQ Living Units.
EQ 8.1	Daylighting	1	Discretionary*
INNOVATION AND DESIGN			
ID	Moisture Control Plan	1	Discretionary*
ID	Bio-Based Products	1	Executive Order 13423
ID	Energy Star/Energy Efficient Products	1	Executive Order 12902 Sec. 301 Executive Order 13423

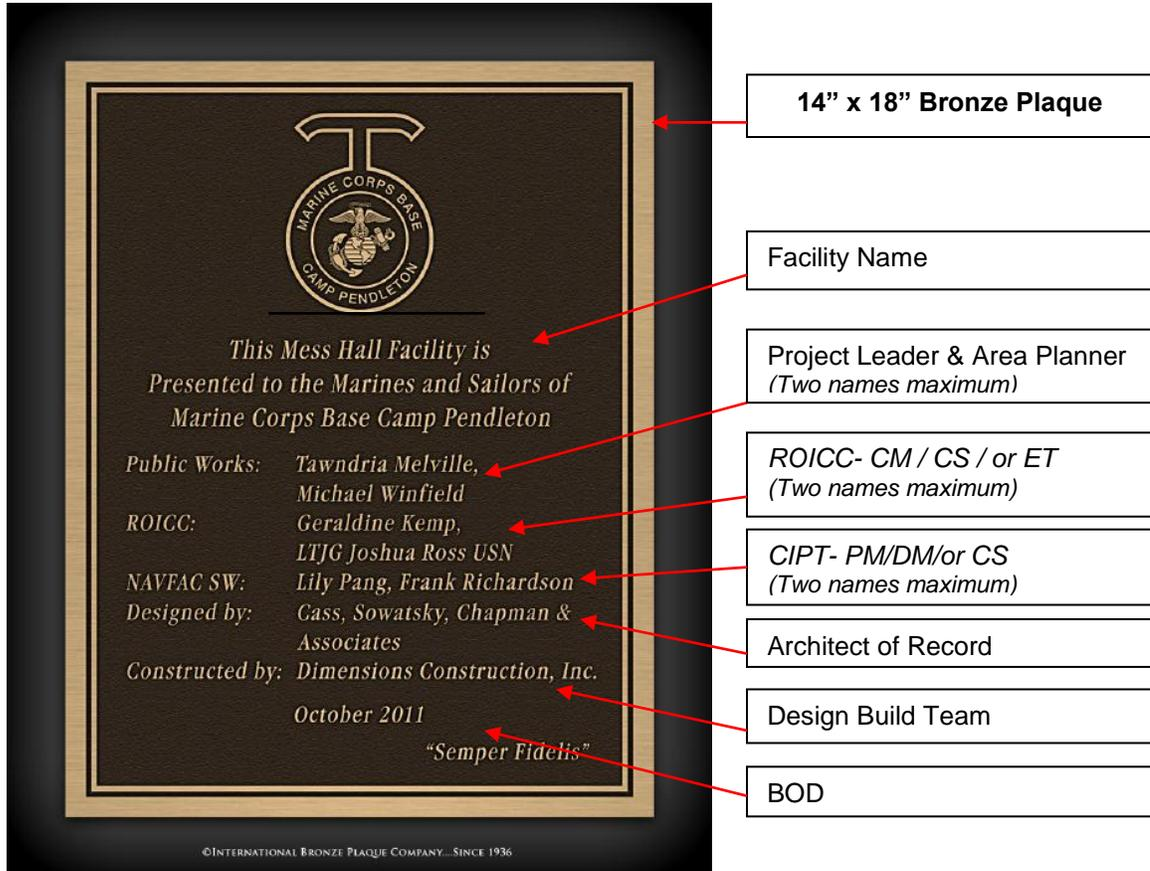
*To be determined on a case by case basis.

Additional Acceptable Strategies for optional LEED-NC v3 credits at MCB Camp Pendleton:

- SS 4.3 Alternative Transportation/Low Emitting & Fuel Efficient Vehicles:
-Electric car ports desirable/Executive Order 13514.
-SWRFT Office manages Base vehicles at MCB Camp Pendleton
- EA Prereq 2: Minimum Energy Performance:
-Use VAC or VAV mechanical systems if technology complies with CPR
(Camp Pendleton Requirements). VRV systems are not allowed.
-Use of re-heat systems desirable
-Geothermal energy should not be explored. Base studies have proven
the ground water does not support the required temperature needed for
geothermal energy design.
- EA 2 On-Site Renewable Energy
Earn an additional point for Regional Priority Credit.
- EA3 Enhanced Commissioning
-Enhanced commissioning is desired of all HVAC systems and controls,
refrigeration systems and controls, renewable energy systems and hot
water systems. Enhanced commissioning is to be provided by third
party. TAB contractor is not permitted to perform the enhanced
commissioning. Return of Contractor after completion of project to
implement Enhanced Commissioning to be enforced; enhanced
commissioning to be under a separate contract from building.
- EA6 Green Power
-NAVFAC does not allow.
- EQ1 Outdoor Air Delivery Monitoring
-Desirable on all buildings. Must interface with MCB Camp Pendleton
EMS (Energy Management System).

101426 BUILDING PLAQUE

1. Attached is the plaque design for all newly constructed buildings on board MCB Camp Pendleton. A plaque should be hung at each new building in a prominent location. *Two names maximum in a group.*



142000 ELEVATOR CONSTRUCTION REQUIREMENTS

All elevator installations shall be required to comply with ASME A17.1 Safety Code for Elevators and Escalators (NOT California Code of Regulations CCR Title 8 Subchapter 6 Elevator Safety Orders), the NAVFAC Elevator Design Guide, the PTS-D10 NAVFAC Performance Technical Specifications, the UFGS-14240 Unified Facilities Guide Specifications Section 142400 for Hydraulic Elevators, and the UFGS-14210 Unified Facilities Guide Specifications Section 142400 for Electric Traction Elevators. The following requirements are to be included as applicable:

1. Machine room and hoist-way construction shall have a 2 hour fire rating. Machine room doors shall have a minimum 1 ½ hour fire rating, be self closing and self locking. Means such as fire rated caulking and foam shall be applied as necessary to add to the control of smoke and gases.
2. Only machinery, equipment, electrical equipment, electrical wiring, raceways, cables, fire detecting systems, pipes, ducts, tanks, and sprinklers used in conjunction with the function or use of the elevator shall be permitted in the elevator machine room and hoist-way.

3. Ventilation means, either natural or mechanical shall be provided in elevator machine rooms and hoist-ways. Machine room temperature and humidity shall be maintained in the range specified by the elevator equipment manufacturer to ensure safe and normal operation of the elevator. Hoist-ways of elevators serving three or more floors shall be equipped with natural or forced means of ventilation. Means such as fire rated caulking and foam shall be applied as necessary to add to the control of smoke and gases.

4. *Elevator Pits:*

Shall have a submersible pump capable of removing a minimum of 3000/hour (50 gal/min) of water per shaft. The submersible pump must move the wastewater minimizing the emulsification of any trace of oil. The submersible pump must be electric, 120V, and can be operated manually or operated automatically. Utilize pumped-flow installation with indirect connection as shown on attached photo "elevator pump".

A control panel must be installed to alert personnel of high oil level, or high water level in the sump. The panel must have audible and visual alarms. Dry contacts must be used to tie into the building automation system. The panel must operate the submersible pump. A hand-off-automatic switch must be used to operate the submersible pump.

Separators must be designed to receive oily wastewater by pump flow and process it on a once-thru or circulating basis. Separators must not have moving parts to fail or that require expensive maintenance. Separator must be specifically designed for elevator sumps which are subject to contamination from elevator equipment. Separators must remove hydraulic and lubrication oils which could be harmful to the sewer system. An automatic stop-valve must be built into the separator which stops flow when separator reaches maximum oil capacity. Separators must be equipped with a high oil float switch, and a high oil alarm panel mounted at a remote location. Authorized waste disposal company must be able to remove oil from the separator. Separator photo attached.

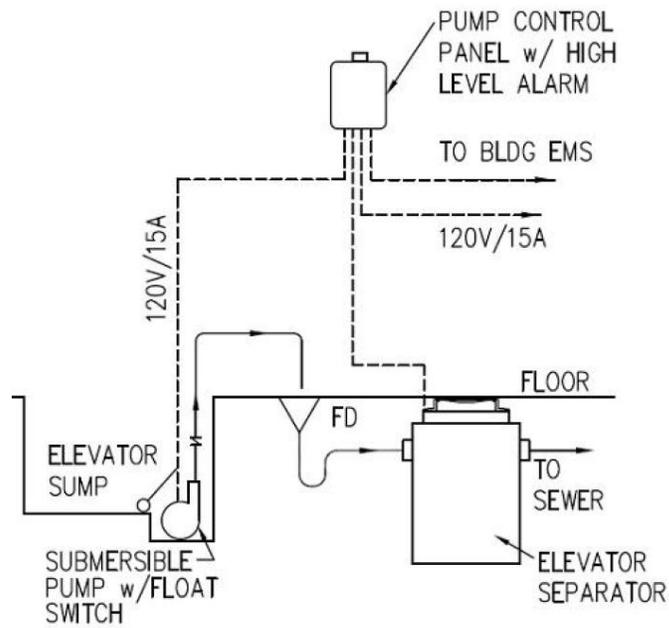
Separators must be structurally and hydraulically engineered conforming to Uniform Plumbing Code. Manufacturer shall submit performance calculations for oil and water separation certified by a licensed professional engineer. Field excavation and preparation shall not be completed prior to delivery of the separator.

Separators must be sized to be twice the capacity of the hydraulic system and NOT THE SUMP (oil spill capacity). For example, if the SYSTEM oil spill capacity is 50 gallons, the separator capacity must be 100 gallons; if the SYSTEM oil spill capacity is 250 gallons, the separator capacity must be 500 gallons.

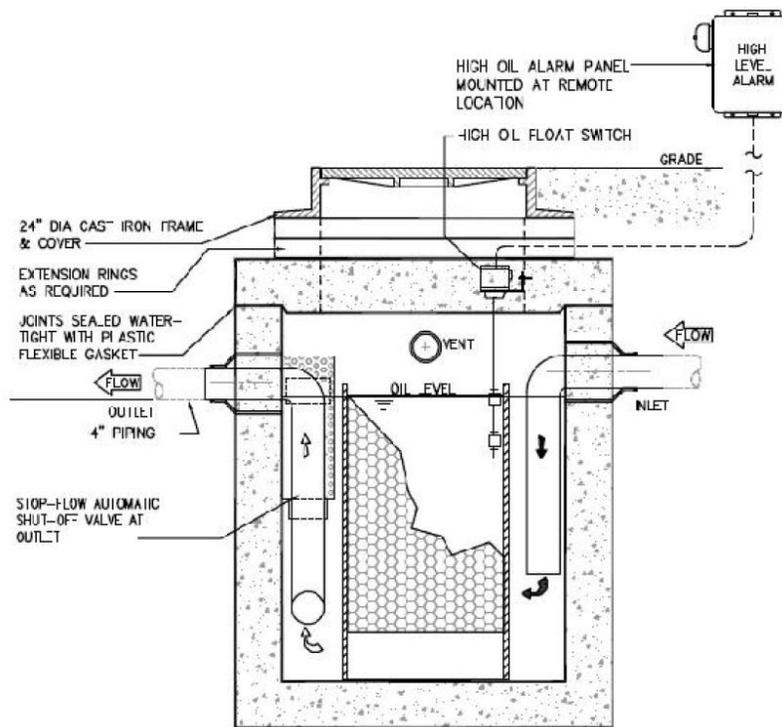
The "hydraulic system" oil capacity includes the sump. Meaning it includes the capacity of the sump and the hydraulic system.

Reference:

- a. ASME A17.7/CSA B 44-07, "Safety Code for Elevators and Escalators" for elevator designs. Water should be treated prior to discharging into the local sewer.



PUMPED-FLOW INSTALLATION
w/ INDIRECT CONNECTION



5. Grout areas and components as necessary, i.e. landing sills at landings and underneath landing sills on the hoist-way side, entrance frames, bottom of guide rails, etc.
6. Seismic requirements shall be provided as follows:
 - a. Hydraulic Elevators shall be provided with an Over-speed/Rupture/Safety Valve/Automatic Shutoff Valve, installed immediately adjacent to the hydraulic cylinder (jack) head.
 - b. Electric Traction Elevators shall be provided with Counterweight Derailment Detection Devices in the hoist-way and Seismic Motion Detection Switches in the machine room.
7. The ASME A17.1 Elevator Safety Code for Elevators and Escalators requires means to automatically shut down elevators prior to the application of water through fire sprinklers located in elevator machine rooms and top of hoist-ways. A NAVFAC Fire Protection Engineer shall determine when a fire sprinkler is required at the top of the hoist-way. Department Of Navy policy requires water flow switches (NOT HEAT DETECTORS) in the fire sprinkler lines to automatically shut down the elevator(s) through a shunt trip circuit breaker. Each water flow switch arrangement shall include a shut off valve, check valve, and inspector's test valve. The water flow switch arrangements shall be installed on the outside of machine rooms and hoist-ways. The control voltage for the shunt trip circuit breaker shall be supervised at the Building fire alarm panel. Water flow switches shall be nonadjustable factory set at zero (0) time delay. Disconnect switches and circuit breakers shall be labeled with circuit identification and origination.
8. Smoke detectors shall be provided in elevator lobbies at all floors and in the elevator machine room. If a fire sprinkler is installed at the top of the hoist-way a smoke detector shall also be installed at the top of the hoist-way. Activation of any one of the smoke detectors mentioned here shall recall the elevator(s) in accordance with ASME A17.1 Safety Code for Elevators and Escalators. The "Fireman's Hat" light indicator located in the elevator car operating panel (COP) shall light continuously when a smoke detector in an elevator lobby is activated, and shall light intermittently (flash on-and-off) when a smoke detector in the elevator machine room or top of hoist-way is activated.
9. GFCI convenience outlets shall be provided in every pit, elevator car top, and machine room. Convenience outlets in pits located less than 48 inch above the pit floor shall have a NEMA- 4 water tight enclosure. Provide label with circuit identification and origination.
10. A fused or circuit breaker type disconnect switch shall be provided for each elevator in the elevator machine room for each 120 VAC dedicated lighting circuit. Lighting switches, disconnect switches, and convenience outlets shall be labeled with circuit identification and origination.
11. A Hydraulic Elevator shall be provided with two (2) oil shut-off valves. One in the pit and one in the elevator machine room. The valves shall be 1500 PSI rated Water/Oil/Gas (WOG) ball valves.
12. All elevators shall be provided with two (2) alarm bells. One bell shall be battery operated, and one shall be a 120 VAC operated bell. Both bells shall be activated through the push button marked "ALARM" located on the elevator car operating panel (COP). Both bells may be installed on the elevator car top.
13. A separate certificate frame shall be provided in the elevator adjacent to or on the elevator car operating panel. The certificate frame shall not be an integral part of the car operating panel that requires opening the car operating panel to gain access to the certificate.

14. All elevators shall be provided with either hall lanterns and gongs at every landing, or car riding lanterns and gongs. Lighting means shall be reliable, long lasting, energy efficient, and be virtually maintenance free.
15. Hydraulic elevators with hole-less/above-ground cylinder-plunger assemblies shall utilize single-stage cylinder-plunger assemblies. Telescopic/multistage hydraulic cylinder-plunger assemblies are prohibited. Hole-Less/Above-Ground hydraulic single-stage cylinder-plunger assemblies shall be installed with the cylinder mounted directly on the pit floor and the plunger connected to the elevator car (inverted installation is prohibited).
16. Elevator guide rails shall be "T" rails. No other type of guide rail is acceptable.
17. Standard safety railing shall be installed on the top of the elevator when the horizontal distance between the edges on the top of the elevator and the hoist-way enclosure exceeds 12 inch.
18. Controllers, controls, control valves, switches, components, devices and tools shall be non-proprietary. Proprietary knowledge, training, tools, programs, software, or hardware shall not be required to operate, adjust, analyze, troubleshoot, or repair the elevator system in its entirety.
19. **Minimum Elevator Cab shall be 6 feet x 8 feet, clear, interior dimensions. Reference also "NAVFAC Elevator Guide" for required numbers and types of elevators per building stories requirements and minimum door opening 4'x7' clear.**

220101 UTILITY REQUIREMENTS

1. *Utility laterals for buildings shall be located so each building connects to a main. i.e., building laterals shall not be linked together in any fashion absent of a main line.*
2. *Utility laterals are prohibited from crossing the site to achieve the shortest distance possible. All Mains are to be located in roadways unless approved by the Public Works Department.*
3. *All utilities located within roadways are to be considered mains and current capacity shall be maintained, e.g., when connecting to a 4" gas main in a roadway, the 4" main must be extended to a point that is perpendicular to the building to be serviced.*
4. *When connecting to utility mains for service and required to extend the main, this project will size the mains so current capacity is maintained.*
5. *For requirements governing the installation of all pipelines by third-parties within railroad right-of-way see APPENDIX, p. 180.*

220519 BASE UTILITY METERS

The base requires all new meters on Camp Pendleton be compatible, field tested & verified with the base Itron wireless RF meter reading system. The system is Itron MV-RS. The meters should be centrally located if feasible. This is handled on a project by project basis.

1. The meter requirements are as follows.
 - a. Electric meters shall be Itron Sentinel or Centron Poly digital meters with ERT/RF output. They shall be able to read demand and large customers to read TOU. Transformer-rated meters shall have a test switch installed in the switchgear or

metering enclosure. *The meter shall be mounted in accordance with SDGE Standards. Test switch wiring and color codes shall match SDG&E standards.* The meter will have a test switch installed in the switchgear or metering cabinet. The only approved forms are 2S, 5S, 9S & 16s. All electric meters shall be programmed at the factory with CPEN customer requirements. *The current transformer ratio shall be written on the face of the meter in the space provided.*

- b. Alternate to above N/A.
 - c. Any poly-phase electric meter installed at CPEN should meet the technical specifications in order to ensure compatibility with the Base's Meter Reading System and data gathering requirements.
2. Gas meters shall be the American brand or equal with an Itron ERT/RF compatible model 100G will data logging or better *and installed per manufacturer's recommendation.* The meter will be sized for the appropriate load of the building(s) *and or cantonement area.* The meter be installed by the contractor & inspected by the Base Gas Distribution personnel after installation.
 3. Water meters shall be Neptune or equal with an Itron ERT/RF compatible model 100W series end point. Units should be mounted on the meter *or* under the pit lid or on the wall of the mechanical room depending on location of meter. This will be decided on a project-by-project basis. The meter will be sized for the appropriate load of the building. The meter will be installed by the contractor & inspected by the Base Water Distribution personnel after installation.
 4. Note: All Water & Gas meters except for special conditions, will be above ground & protected from physical damage. Large master meters will also be fenced with gravel or concrete pads. Working clearance must be approved by Base FMD personnel.

Recommended local vendors:

Electric Meters- McAvoy & Markham Engineering & Sales Co. (949) 727-3966

Gas Meters- US Metering & Technology (888) 651-1130; Submeter Solutions, Inc. (888) 646-3837; Measurement Control Systems, Inc. (800) 826-1682

Water Meters – Equarius Waterworks, (424) 271-2898; Todd Piping Supply, (310) 349-5100; Ferguson, (619) 515-0300

Questions on these specifications should be directed to the CPEN Energy Office.
Phone Number 760-725-0567

ADVANCED METERING INFRASTRUCTURE

MCI West G6

(Formerly Communications and Information Systems (CIS))

1. *MCI West G6 responsibility and involvement with the cellular repeaters:*
 - a. *MCI West G6 does have eyes and ears regarding the planning and installation processes, including pathways and routing, and agrees to perform a QC walk-thru when appropriate.*
 - b. *MCI West G6 will verify there are no physical or operational conflicts between Base Communications requirements (as stated in the CPR) and the Commercial product requirements.*
 - c. *MCI West G6 does NOT assume responsibility for Installation, Commissioning, Operation, or Maintenance of a commercial communication system.*

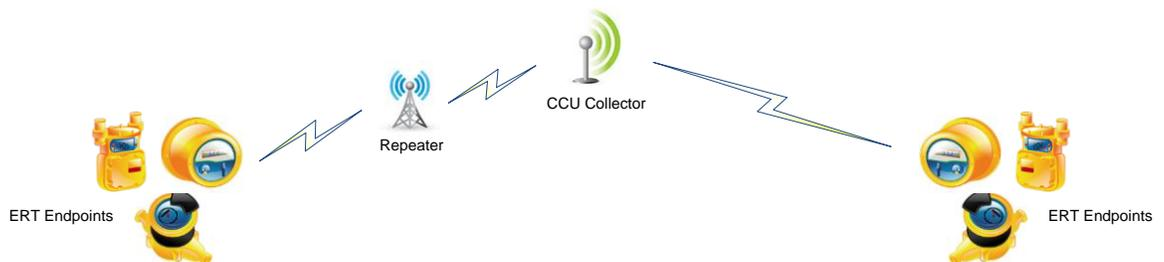
- d. Each project shall be viewed as having site specific requirements. As such, all projects shall be approved by MCI West G6 and the Base Energy Office.

Overview

1. Regarding the Advanced Metering Infrastructure (AMI), as of this writing, the specifics of the AMI is not included UFC_3_580_01 or UFC_3_580_10. Contact, Jeff Allen (energy office) and Brian Church with FMD at MCB Camp Pendleton as the main subject matter experts to clarify details until UFC guidance is updated.

Basic Theory

1. Signals (data) from the meter source (endpoints) are transmitted via RF to a collector. The meter must use Encoder Receiver Transmitter (ERT) technology compatible with the collector. In some cases, it may be necessary to supplement the signal strength of an endpoint with a repeater.



2. The goal is to transmit the meter data from the collector to the “Fixed Network” data repository. The collector must have access to an IP transport architecture. From the collector, the signal transport can be via hard-wire or RF (Wi-Fi).
3. If using RF, data from the collector must be relayed to a subscriber RF unit. The RF subscriber unit must be configured to communicate with an RF Access point connected to the Ethernet Backhaul. IP addresses for the collector and RF subscriber unit must be requested and assigned. (See concept drawing 1)
If the collector is to use physical cabling to reach the base backhaul, copper or fiber optic may be used to connect and interface with data switching equipment inside the telecommunications room. An IP address must be requested and assigned to provide data communications with the appropriate Network Application server (for example, with FMD/Unity). (See concept drawing 2)

Major Components

1. Below is some information regarding major components of the AMI:
 - a. Meters (endpoints), Repeaters, Collectors, RF Ethernet radios, Ethernet switches, cabling)
 - b. Power Supply Unit(s)
 - c. External Conduit(s) and Path
 - d. Cabling - types and terminations (external, internal); protection (physical and functional)
 - e. NMCI Ethernet - bandwidth (IP Address), interconnects, and data ports
 - f. Voice/Data Connectivity from MCI West G6 Telecommunications Equipment Room (TER) to Campus Distributor (Area Distribution Node - ADN) or Exchange/switch

Placement of the collectors within an Area

1. For collectors which are physically cabled to the TR, here are cabling types and the allowable distances for such a setup from Collector to Telco Room (end-to-end):
 - a. Use Copper Cat6/6A (24 AWG shielded twisted pair) if distance is 295 feet or less.
 - b. Use Copper Cat 3 PE-89 (24 AWG twisted pair for distances up to 18,000 feet (load coils needed when over 5,000 ft).
 - c. Use Fiber Optic Cable (FOC) SSM PE-90 – Best for long-haul distances (requires SC duplex termination). Can be used for applications over 18 inches.
2. Note: All copper and fiber cabling must be run in rigid conduit when installed external to a building.
3. Collectors that use RF to communicate data to the backhaul must be installed in a manner consistent with the collector manufacturer's installation documents.
 - a. Select approved radio subscriber unit
 - b. Ensure that collector location is consistent with the base RF study

Notes:

- a. All copper cabling running from an external source to the building's TER requires a protected entrance termination (PET) before connecting to MCI West G6 or NMCI equipment inside the TR.
- b. All external cabling must be run through rigid conduit. [Refer to the CPR and UFC for conduit details].
- c. Enterprise Zone Modules placed in 'communication rooms' are NOT to be installed inside 'MCI West G6 -owned/operated' TERs. To be clear, any design or concept statement must state something to the effect as, "non-MCI West G6 telecommunications equipment rooms (TER)." The reason is that MCI West G6 TERs must be dedicated and/or exclusive for DOD security purposes. This mean AMI or any other commercial enterprise system cannot share the same equipment room containing MCI West G6 telecommunications equipment. Any demarcation points between MCI West G6 and Commercial systems must be negotiated, justified, and approved by MCI West G6 IT Security Mgr and the MCI West G6). Other security and approvals may also apply.

Conceptual Examples

Fixed Network Backhaul Communications Flow

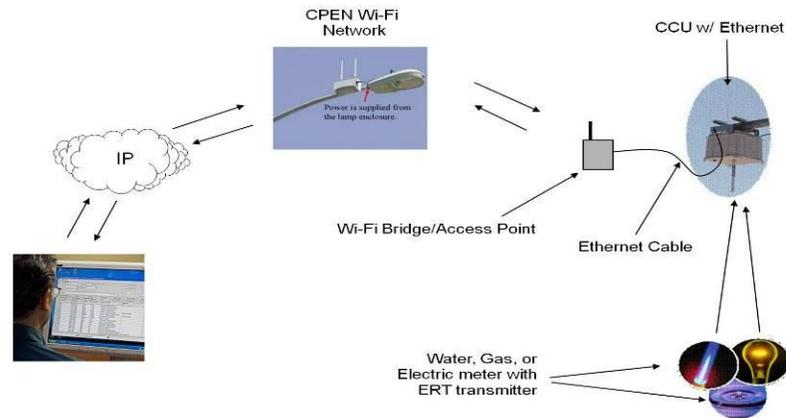
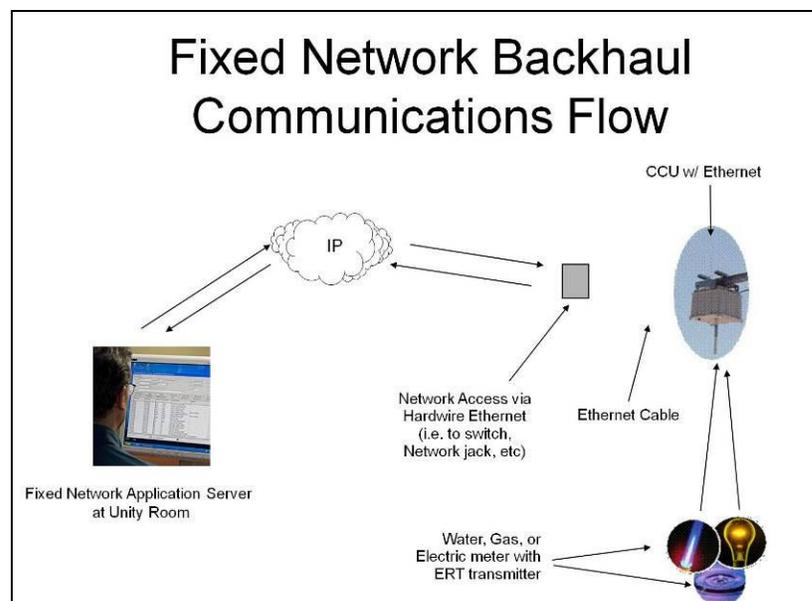


Figure 1. Backhaul Concept 1 – Wireless connection between Collector and Data Repository



220520 BASE INFORMATION SYSTEM ACCREDITATION

1. The base requires that all modifications to existing Information System components and installation of new Information System hardware & software components connecting to the existing Unity system obtain accreditation through the DoD Information Assurance Certification and Accreditation Process (DIACAP). Detailed information on DIACAP can be accessed through the following link: <http://iase.disa.mil/diacap/>.
2. The contractor shall obtain approval from the Base prior to ordering any Information System hardware or software. The information systems and programming shall be provided so the equipment functions together as an integrated system at the unit process level, the plant level, and the system-wide level.

221110 and 221113 POTABLE WATER REQUIREMENTS

GENERAL

1. *Prior to any construction of a utility connection, all construction plans for a water system service connection shall be submitted to the PW Utility Team and/or FMD Water Department for approval. Contractor shall comply with Safe Water.*
2. All water works construction shall conform with the latest version of CPR and SDWA requirements to the most recent Unified Facilities Criteria (UFC) and Code of Federal Regulation (CFR) requirements. In case of a conflict of requirements, the most stringent shall govern. If the standard sought does not appear in these requirements, then the latest edition of the following standards shall be utilized in the order listed:
 - a. *California Department of Public Health.*
 - b. *California Code of Regulations*
 - c. *American Water Works Association (AWWA) Standards.*
 - d. *City of Oceanside Water, Sewer and Reclaimed Water Design and Construction Manual.*
 - e. *San Diego County Regional Standard Drawings.*
 - f. *Standard Specifications for Public Works Construction (SSPWC or Greenbook) latest edition.*

WATER PIPE MATERIAL

1. **Transmission Lines** (*water lines from wells to Water Treatment Plants or Reservoirs and primary mains to cantonments areas*)

Material shall be High Density Polyethylene (HDPE) per AWWA C901 and C906 unless approved in advance by PW Utilities Team. Drawings must be submitted and approved by PW Utility Team before ordering materials.

2. **Distribution lines or Fire Loops** (*water lines contained within cantonments 8 inch ID or less*)

Material shall be High Density Polyethylene (HDPE) per AWWA C901 and C906 unless approved in advance by PW Utility Team. Drawings must be submitted and approved by PW Utility Team before ordering materials.

3. **Lateral lines** (*water lines from distribution lines to POC at facilities, or single lateral lines to fire hydrants*)

For lateral lines 4 inch diameter or less, material shall be PVC schedule 80 or approved equal. For lateral lines greater than 4 inch diameter, material shall be PVC per AWWA C-900 and C-905 (per pressure requirements) or approved equal. The limits of the lateral lines are from the connection at the distribution line to a stub-out 5 feet from the building. Code requires 10 feet copper (type K) from the end of the lateral to a connection to the interior of the building. The interior plumbing shall be either copper (type K) or Schedule 80 PVC, as required by the RFP.

4. **Irrigation Lines** (*water lines used to provide water to vegetation and not direct human consumption*)

Material shall be Schedule 40/80 per pressure requirement PVC color purple (reclaimed water)

LARGE and MULTISTORY BUILDINGS:

1. The contractor shall install water shutoff valves in the domestic water system which will allow individual floors or wings to be shut off without shutting off the water supply to the remainder of the facility. Shut off valves shall be easily accessible and shall be located in corridors or mechanical rooms only. Shut off valves shall not be installed in living spaces or offices.

FIRE HYDRANTS

NOTE: For additional information on Fire hydrants, reference "Water Loop Requirements" and "New Connections to the Existing Water System" on the following pages.

1. All fire hydrants shall comply with the following regardless of whether the facility is sprinklered or unsprinklered.
2. All fire protection supply hydrants shall be 2.5" x 2.5" x 4.0" and shall meet the requirements of UFC 3-600-01, Section 3-7.2.1, NOTE 2, or the following whichever is more restrictive.
3. The contractor will be responsible for obtaining or performing fire flow tests as part of the process. Fire flow tests must be recorded on the Hydrant Flow Test Report and submitted to PW Utilities Team. All Hydrant testing will be performed by MCB Water Dept or properly licensed Chief Operator. The hydrant flow test procedures and report are at the end of the Potable Water Requirements section under "attachments". All new or existing facility projects shall have fire hydrants capable of providing a minimum flow of 1,250 gpm at 20 psi residual for two (2) hours. In the event the existing water distribution system is unable to accommodate these pressures or flows, the contractor shall provide an alternate solution incorporating a fire pump and/or water storage tanks for approval from PW Utilities Team and shall be responsible for including this item(s) in determining the bid on the project.
4. A facility being served by a single fire hydrant may be served by a single lateral on an un-looped system subject to review of PWD. An Automatic Flush valve SHALL be installed. This lateral shall have a minimum internal diameter of **8 inches**. Should multiple hydrants be required along a single lateral, they SHALL be in a loop, per BUMED INST 5010-5 latest edition.
5. A facility or group of facilities requiring more than one fire hydrant shall be installed on a looped system. The loop and the laterals serving the fire hydrants shall have a minimum internal diameter of 8 inches and shall conform to the maximum allowable velocities listed below.
6. Pipes shall be sized based on the following criteria:
 - a. Maximum allowable velocity at average day demands = 5 ft/s.
 - b. Maximum allowable velocity at max day & peak hour demands = 7 ft/s.
 - c. Maximum allowable velocity at max day demands + fire flow = 10 ft/s.
7. Fire Hydrant configuration SHALL follow, in priority: 1. CPR, 2. UFC 3-600-01 Fire Protection Engineering for Facilities and shall comply with the requirements of the City of San Diego Regional Standard Drawing SDW-104.

The following requirements are in addition to what is in the referenced UFC section:

- a. *UFC 3-7.3.2 Installation Requirements: Hydrant shall have a buried watch valve to isolate the hydrant if damaged and the lower section of the hydrant flange or breakaway spool shall be minimum of 2"-4" above finished grade or concrete pad.*
 - b. *UFC 3-7.3.4 Hydrant Protection: Hydrants installed within three feet of the curb must be protected by bollards.*
 - c. *Bollards shall comply with San Diego Regional Standard Drawing WM-4.*
8. *All isolation valves to shut off a hydrant shall be installed within 10 ft of the hydrant. UFC 600-01 SEC 3-7.3 notes a 5'-10' MIN/MAX valve distance from hydrants.*
 9. *Hydrants to be California Wet Barrel type Hydrants with one 4" (100mm) suction and two 2.5" connections minimum. All fire hydrant supply ports shall contain (2 ea) 2.5" and (1 ea) 4" hose connections.*

ATTACHMENTS:

MCBCP HYDRANT FLOW TEST PROCEDURES

1. *Due to insufficient data collection of hydrant flow test data aboard Camp Pendleton, the following Hydrant Flow Testing Procedures have been developed in order to accurately capture and compile the data. The data secured during the testing of hydrants and recorded on a standard form and compiled for future use will be extremely valuable for the analysis of the current Basewide Fire Protection and Water Distribution System capabilities. With this in mind, it is required that the following procedures be utilized for every hydrant flow test on the Base.*
2. *For Contractors who need to perform hydrant flow tests aboard Camp Pendleton for a project, the ROICC CM/ET should use the following procedures to coordinate the testing:*
 - a. *Following a request from the Contractor for a hydrant flow test, the ROICC shall coordinate the fire flow test with the following departments:*
 - b. *The ROICC shall contact the Facilities Maintenance Department (FMD) to observe and operate the hydrant valve (opening and closing to prevent water hammering of the system) and to determine the status of lines in the vicinity [repairs, out of service, excessive load, supply closed, etc...], and to advise the time and location of hydrant testing.*
 - c. *The ROICC shall also contact the Fire Department, Fire Prevention Office to advise the time and location of hydrant testing if the Fire Department wants to coordinate with area officials. The Fire Prevention Inspector may or may not decide to be present during the testing.*
 - d. *The ROICC shall provide the contractor with the Hydrant Flow Test Report (attached) prior to the hydrant flow testing to be completed by the Contractor during the test.*
 - e. *The ROICC shall obtain a completed copy of the Hydrant Flow Test Report and submit the copy (on paper or electronically) within 5 days to the Public Works Department Utility Team.*

HYDRANT FLOW TEST REPORT

[Adapted from the 2010 NFPA 291 Figure 4.11.2 Sample Report of a Hydrant Flow Test]

NOTE: Contractors shall submit a copy of this completed report to the ROICC CM/ET for the project.

LOCATION MAP:

- Include a sketch of the location of the hydrants including hydrant IDs, and streets or intersections on the back of this form.
- To the extent possible, show connecting lines, line sizes, and distance to next cross-connected line, valves, and hydrant branch size. Indicate North.
- Show flowing hydrants – Label A1, A2, A3, A4. Show location of static and residual hydrant – Label B.
Indicate B: Hydrant Sprinkler Other (identify)

Project number/title _____

Location _____

Test made by _____

Date/Time _____

Representative of _____

Witness _____

State purpose of test _____

If pumps affect test, indicate pumps operating

Flow hydrants _____ A₁ A₂ A₃ A₄

Size nozzle

Pitot reading

Discharge coefficient _____ Total gpm

GPM

Static B _____ psi Residual B _____ psi

Projected results @20 psi Residual _____ gpm; or @ _____ psi Residual _____ gpm

Remarks:

WATER LOOP REQUIREMENTS

1. *Per MCO 5090.2A and BUMED Instruction 5010-5 (Rev 6-2008 or latest edition) 0510-LP-107-3451, Chapter 5, "Water Supply Ashore."...Requires potable and fire suppression water systems to be designed in a Loop, i.e. continuous circulation pattern. This is to minimize any section of the water supply from becoming septic...The following requirements (2&3), are included as further direction to designers and constructors of new or reconditioned water services on-board MCB CPEN.*
2. *Water service for new construction shall be provided by a looped system. Dead end water lateral lines (other than building connections and fire hydrants) require the approval of Public Works (PW) in the design phase. All dead ends shall be fitted with appropriate automatic flushers. Water loop systems shall be connected to two separate water supply mains. This is defined as two separate sources of supply where if one connection is shut down, there is a second water supply to the project site. In the case where the secondary water main is more than 1,000 feet from the facility, the contractor will be allowed to connect to the same water main. However, in this event, the two points of connection shall be a minimum of 100 feet apart, with a tee and three valve cluster at each point of connection.*
3. *Water loops shall be designed to fall within the footprint of the approved Environmental Boundary (EA, CATX, etc). If a water loop cannot be installed within this boundary the contractor shall contact Public Works before beginning their design. This will include all ground disturbance.*

NEW CONNECTIONS TO THE EXISTING WATER SYSTEM

1. *Connections to existing pipelines shall be made with the installation of a Tee with three (3) valve cluster and the design must be approved by PW Utility Team or FMD Water Department prior to performing the work. The connection sequence shall be as follows: The existing pipeline shall be drained; the Tee with a three valve cluster shall be installed; FMD Water Department approval of the connection shall occur prior to re-filling of the existing pipeline.*
2. *In certain exceptional instances, and only where approved by PW Utility Team, wet (hot) tapping may be allowed as follows: A wet tap design and plan of execution will be submitted to PW Utility Team prior to performing the work. The plan of execution will include the qualifications of the wet tap contractor. New installed wet taps of 8.0" O.D. maximum are limited to 1/3 I.D. of connecting water line. The contractor shall install a tapping saddle and gate or plug valve and make the wet tap.*
3. *New connections to existing lines solely for the purpose of a hydrant or blow off valve may be performed with a single valve to isolate the hydrant provided the prior appropriate approval of the PW Utility Team or FMD Water Department has been granted.*
4. *Auto flushing valves shall be installed on any single line hydrant.*
5. *Also reference "Fire Hydrants" Section on previous page.*

WATER SYSTEM STANDARD DETAILS

Standard construction details are per City of Oceanside or San Diego County Requirements.

Exceptions to the above standards are as follows:

1. Pressure Regulating Valve (PRV) stations shall be above ground, on concrete pads with fence or cover. *They shall have OS and Y valves installed as isolation valves. The pressure sustaining/regulating valves will be equipped with stem indicating assemblies and pressure gauges, indicating upstream and downstream pressures. The PRV station will have a means to remove stale water prior to being placed in service.*
2. *All Blow off and Air Relief/Vacuum Assemblies are to be located above ground in compliance with California Waterworks Standards Section 64576 and 64575.*
3. Back flow preventers, DCDA's and RPPA's are per San Diego County Requirements but with an isolation valve.
 - a. *Access and clearance must require a minimum of one (1) foot between the lowest portion of the assembly and grade, floor, or platform and a two (2) foot clearance around the entire backflow device for maintenance access. Installations elevated more than five (5) feet above the floor or grade must be provided with a platform capable of supporting a tester or maintenance person.*
 - b. *Whenever a backflow preventer is installed the diameter of the supply pipe shall remain the same from the inlet to the outlet side of the backflow device and shall never decrease in diameter at anytime.*
 - c. *Backflow preventer concrete pad: Backflow devices larger than two inches in size shall have a concrete pad installed. The concrete pad shall be 6" thick concrete with wire mesh and shall be sized so that there is a minimum of 2 horizontal feet from the edge of the equipment (farthest point from center line) to the edge of the concrete pad. The pipe risers shall be encased in a collar and the collar shall be filled on the inside with sand or a comparable material.*
 - d. *All backflow devices shall have a below-ground isolation valve adjacent to the upstream side of the backflow preventer riser. The backflow device will have an above-ground isolation valve installed upstream and downstream of the backflow device.*
4. Minimum *compacted* depth of cover required:
 - a. *36 inches for 12-inch mains and smaller. Depths less than 36 inch requirement requires encasement and Public Works Utility Team approval.*
 - b. *Mains over 12 inches require special design and approval at the design stage.*
 - c. *Potable water lines shall not be installed underneath or cross underneath wastewater/stormwater lines and shall follow standards specified in CCR Title 17 &.64572 Water Main Separation.*

Free Chlorine Residual. Certified test results shall be returned to the Government for review and approval by the FMD Chemist prior to lines being returned to service. Test results shall include sample location and project number. Only certified and authorized FMD Water Distribution Operators may operate valves to return new or repaired lines to service.

- 3. All permanent chlorine delivery piping shall utilize one-quarter turn sweeps in lieu of 90 degree elbows, and shall be constructed of Schedule 80 C-PVC or equal unless approved in writing in advance by the Government.*

VALVES

- 1. For all work on existing water systems (remodel, rehabilitation of existing structures), the contractor shall replace all valves with lead joints within the project footprint with lead-free valves and joints.*
- 2. Butterfly and rising stem valves are for above grade installation only.*
- 3. Only single-disc, non-rising stem, resilient seat gate valves shall be installed into new or existing below grade water lines. Double disc valves are not allowed.*
 - a. "Single-disc" requirements need to include: The wedge shall be of cast iron completely encapsulated with rubber. The sealing rubber shall be permanently bonded to the cast iron wedge to meet. ASTM test for rubber metal bond ASTM D429. Valves shall be supplied with o-ring seal at all joints. The stem nut shall be independent of the wedge and shall be made of solid bronze/ there shall be a smooth, unobstructed waterway free of all pockets, cavities and depressions in the seat area. The body and bonnet shall be coated with fusion bonded epoxy both interior and exterior, complying with AWWA C550 and be NSF 61 approved. Each valve shall have the maker's name, pressure rating and year in which manufactured cast on the body and electro-plated nuts and bolts.*
- 4. All water valve boxes shall be of the screw type, minimum 5-1/4" shaft diameter, cast iron construction, consist of a base section, middle section (if required) and top section. Plastic valve covers are not acceptable. Water line valves shall be molded with the word "WATER" in the center and painted blue. Irrigation valves shall be molded with the word "IRRIGATION" in the center. Raw water line valves shall be molded with the words "RAW WATER" in the center painted red.*

ISOLATION VALVE

- 1. Install approved hot & cold water isolation ball valves to each BEQ floor and wing to minimize water outage interruptions during repairs.*

WATER SOFTENER

- 1. All commercial kitchens shall be plumbed for water softener equipment.*
- 2. Number of tanks and location to be coordinated with softener provider.*
- 3. The use of sodium or potassium salt self-regenerating exchange processes is not allowed.*
- 4. Water softener piping shall have a separate meter (digital read-out meter to track soft water usage) and shall only be connected to food service equipment.*

HIGH PURITY PIPING SYSTEMS

1. *High Purity Water lines shall be constructed of specialty manufactured Schedule 80 PVC material NSF-61 approved. This is non-contaminating PVC material with exceptionally smooth surface characteristics to prevent entrapment of bacteriological matter.*

WELL CONSTRUCTION

1. Wells shall be constructed as per the California Department of Water Resources-Southern District. All appurtenances of the well shall be attached with structural shoulder bolts, washers, and nuts; torque to standards, witnessed and torque striped, with at least three threads exposed beyond the nut. *Columns and casing shall be Type 304 Passivated Stainless Steel with Type 316 Passivated Stainless Steel threaded locking collars and screens.*
2. *Exceptions to the above standards are as follows:*
 - a. *NOTE: All observation, turn-on/shut down will be performed by MCB Water Dept or properly licensed Chief Operator.*
 - b. *304 SS Wire Wound Screens.*
 - c. *304 SS Well Casings.*
 - d. *304 SS Pump Columns (with threaded connector couplings).*
 - e. *316 SS pump shafts.*
 - f. *3" Diameter 304 SS Sounding tubes with electronic transducer installed.*
 - g. *2" Diameter port capped or plugged at top of well casing aligned along inside face of well casing for use in placing well depth tape measurement tape device. Placed so that the drop is straight down into the casing between pump column and the well casing without any obstruction.*
 - h. *All controls, meters and gauges shall be set at a height so as to be accessible by persons of average height.*
 - i. *All doors to have "Hold-Open" door closers installed.*
 - j. *All doors and frames to be aluminum with anodized finish color as per BEAP.*
 - k. *All above ground piping to be mechanical fitting Ductile Iron, including pump control and high pressure relief discharge lines.*
 - l. *Surge anticipators are not to be installed.*
 - m. *All wells shall be equipped with emergency low water level shutdown with a soft alarm to unity. A local bypass to the emergency shutdown shall also be installed at the well head to override a shutdown should it be necessary by a Water Department operator.*
 - n. *Air pressure gauges for surge suppressor tank shall be accessible by persons of average height.*
 - o. *Glass block windows type to be of pre-manufactured unit prepared in an aluminum frame.*
 - p. *Surface Annular Seal (Sanitary Seal Required by CDPH). The space between the borehole wall and the well casing shall be sealed to the depth or to a greater depth than that required by the California Department of Water Resources Bulletin 74-81 "Water Well Standards, State of California" and its supplement Bulletin 74-90. Seal material and placement of the seal material shall also conform to the California Department of Water Resources Bulletin 74-81 "Water Well Standards, State of California" and its supplement Bulletin 74-90.*
 - q. *Any and all controls, meters, etc, shall be ergonomically packaged so that all are in easy reach and vision levels without stooping or requiring steps or ladders to view in the proper perspective.*
 - r. *Sampling devices will be constructed of "Lead Free" brass connections, with quarter-turn ball valves, and Stainless Steel 180° gooseneck downturn tubing.*

221316 WASTE WATER REQUIREMENTS

GENERAL

1. *Prior to any construction of a utility connection, all construction plans for a wastewater system service connection shall be submitted to and approved by PW Utility Team and/or FMD Wastewater Department in order to ensure compliance with standards set forth within these requirements.*
2. All sewer system construction shall conform to the most recent *Camp Pendleton Requirements*, Unified Facilities Criteria (UFC) and Code of Federal Regulation (CFR) requirements. If the standard sought does not appear in these requirements, then the latest edition of the following standards shall be utilized in the order listed:
 - a. *California Department of Public Health (CDPH).*
 - b. *American Water Works Association (AWWA) Standards.*
 - c. *City of Oceanside Water, Sewer and Reclaimed Water Design and Construction Manual.*
 - d. *San Diego County Regional Standard Drawings.*
 - e. *Standard Specifications for Public Works Construction (SSPWC or Greenbook) latest edition.*
3. *The new/repared sewer lines associated with building construction/repair should be cleaned and CCTV to ensure the lines are undisturbed and clear of debris after repairs have been complete. The video should contain the pipe segment numbers, direction of survey, manholes associated with the sewer main, pipe size, material, and distance traveled. Any deficiencies or debris found should be corrected by the contractor.*

WASTEWATER CONVEYANCE PIPE MATERIAL, SIZE, and VELOCITY

Gravity lines (includes trunk lines, main lines, and building connections)

1. *Minimum size of building connection lines and lateral lines shall be 6 inches. The minimum size of main lines shall be 8 inches. For all gravity lines, a minimum velocity of 2.5 feet per second (ft/s) shall be maintained at maximum peak wet weather flow.*
2. *For wastewater pipes less than 8 inches diameter, material shall be PVC SDR-35 and shall meet ASTM D3034 requirements. For wastewater pipes equal to or greater than 8 inches diameter, material shall be PVC SDR-35, and shall be fused and seamless.*
3. *The minimum depth of cover required is 48 inches.*

Force main lines

1. *Material shall be HDPE SDR-26. The maximum and minimum allowable velocity is 6.5 ft/s and 2.5 ft/s, respectively.*
2. *The minimum depth of cover required is 48 inches. Mains over 12 inches require special design and shall be submitted and approved by the PW Utility Team.*

MANHOLES (Sanitary Manhole and Sewer Manhole)

The location of manholes shall conform to the following:

1. *Manholes shall be provided at all pipe intersections and at changes in elevation, direction, size, diameter and shape.*
2. *Manholes shall be placed a maximum of 400 ft apart in the closest paved street.*

3. *Manholes shall be accessible via a vector truck supportable path for the sewer cleaning, flushing, and vactoring and for vector truck access. Manholes shall be installed level to a ½" above finish grade to prevent submergence of the manhole cover.*
4. *Manholes shall not be placed in the following locations:*
 - a. *Gutters and other depressions.*
 - b. *Sidewalks, crosswalks, private yards, high pedestrian traffic areas, building entrance and public gathering areas.*
 - c. *Within twenty feet of an occupied residence building or messhall. If it is within 20 feet of unoccupied structure, an approved gas tight manhole cover shall be installed.*
 - d. *Within any area subject to flooding.*
 - e. *Athletic fields or sports courts.*
 - f. *A Sewer cleanout shall not be installed or placed within 5' in any direction from the storm drain grate or catch basin inlet.*

SEWER LIFT STATION (SLS)

Design and Construction Submittals

1. Complete Design Submittal under RFP Part 3, Chapter 6, Section G3020, Sanitary Sewer. **REFERENCES:** UFC 3-240-06A , WASTEWATER COLLECTION AND PUMPING (16 January 2004) and The City of San Diego, SEWER DESIGN GUIDE (2004)
2. Provide Construction and Design Documents in accordance with all applicable Contract Requirements, including the RFP Part 2 Sections.
3. Sewer Lifting Station (SLS) Submittal Register shall include Construction and Design Documents supporting SLS. The Design Analysis shall include:
 - a. Basis of Design (BOD)
 - b. Code and Criteria Search (CCS)
 - c. Design Calculations
4. The SLS BOD shall include a description of project concepts that address salient points of the design Including the following:
 - a. UFC 3-200-10N requirements, including, but not limited to, Section 3-2.1, Civil Basis of Design (BOD) and Section 3-2.1.10, Sanitary Sewer.
 - b. How pump duty is controlled and cycled among the three pumps.
 - c. Telemetry requirements and compatibility with existing Base System.
 - i. Unity Alarms should include the following: high alarm, low alarm, pump run status, seal failure alarm, over-temperature alarm, generator status, flow, discharge pressure.
 - ii. Any connections to Unity shall be coordinated with the FMD Unity Operators.
 - d. RFP Part 3 requirement to provide multiple force mains as necessary to enable expansion from commissioning to full lift station capacity.
 - e. RFP Part 3 requirement to provide fail safe devices based on failure mode analysis.
 - f. *RFP Part 3 wet well and emergency storage volume requirement (see below for complete wet well and emergency volume storage requirements).*
 - g. RFP Part 4 Performance Technical Specification (PTS) Requirements.
5. The construction submittals should include all equipment and material to be reviewed and approved by the Engineer of Record. These submittals should include the pumps, motors, controls, electric power panel, influent grinder pump, odor control chemical tank,

emergency generator, flow meter, pressure transmitter, connection to Unity, emergency overflow tank, valves, pipe and fittings, etc.

6. Conduct a surge analysis and include as part of design submittal.
7. Provide flow calculations for a catastrophic failure in the event all power to the lift station is lost (if the emergency generator doesn't start and perform as expected). Provide with those flow times for normal, peak and maximum calculated peak demand so FMD has sufficient time to respond to the crisis and get all the portable pumping equipment connected in time to prevent a spill. The sewer lines and manhole system would need to provide the retention time necessary to allow FMD to respond. These flow calculations are important to fully understand the total system capacity and to identify any need to provide additional overflow storage capacity.

The wet well and emergency storage volume shall conform to the following requirements:

7.2.6.7 Emergency Storage Volume: Separate from the wet well operating volume, the DESIGN ENGINEER shall provide an emergency storage volume sufficient to accommodate a storage of two-hour pumping volume at peak wet weather flow. The total pump station sewage storage volume (i.e., volume of the wet well above the pump "off" level to the lowest sewage spill point) can be accomplished by the following measures singly or in combination, and listed in order of preference: additional storage in the wet well above the operating volume, separate overflow tank and storage in the inlet line to the spill level. This "emergency repair holding time" will allow operating personnel at least two (2) hours to respond to a station failure alarm and/or to shut off all pumps to perform emergency repairs to correct a failure condition. In addition, this storage is also available to be utilized for flow equalization during large storm events should peak wet weather inflow exceed the pump station design capacity.

7.2.6.8 Influent Line Storage: The wet well influent sewer shall not be designed to accommodate storage except as required for "emergency repair holding time" as described in Section 7.2.6.7 (note: this causes grease buildup problems in the inlet line). This storage shall be utilized where it is not practical to provide two-hour emergency storage in the wet well and/or separate overflow storage tank.

7.2.6.9 Spill Location Indication: Influent sewer and pump station spill locations shall be indicated on the design drawings (lowest upstream elevation or wet well cover elevation where backup spill will occur). Mean sea level (MSL) elevation shall be included for information for spill location.

7.2.7 A SIX-HOUR EMERGENCY STORAGE (SPECIAL STATION REQUIREMENT)

7.2.7.1 Closed Tanks: In areas where maximum protection from spillage must be provided, such as areas where a station sewage spill would flow into a water supply reservoir or other sensitive areas as determined by the Senior Civil Engineer, a six-hour emergency overflow storage (at peak wet weather inflow rate) shall be provided. This storage requirement is in addition to the wet well operational storage. The emergency storage can be an underground structure or a separate tank that is normally empty but can drain by gravity back into the wet well. Similar to section 7.2.6.7 above, this storage is also available to be utilized for flow equalization during large storm events should peak wet weather inflows exceed the pump station design capacity.

(City of San Diego Design Guide 2004 for lift station emergency storage)

General Lift Station Requirements

In addition to the above submittal requirements, wastewater lift stations shall include the following:

1. *All SLSs require a properly sized emergency backup diesel generator*
2. *All SLSs require 3 pumps minimum.*
3. *Wet wells and all concrete components exposed to waste water shall be lined with a post cured spray or brushed on water proofing material.*
4. *Corrosion resistant materials shall be used for all mechanical and electrical components, including impellers. Type 316 Passivated Stainless steel for brackets, supports and impellers. Fiberglass grating and ladders. Exterior of ductile iron piping (if approved for use) shall be epoxy coated.*
5. *Pump stations shall be equipped with soft start motor controllers or VFD's, to reduce surge pressures and reduce the impact on downstream treatment components.*
6. *Station shall have ultrasonic as primary and float backup. Pumps shall alternate between all 3 pumps. High level alarm will send alarm to UNITY high/high float will call for all 3 pumps to run.*
7. *Low level alarm will send alarm to UNITY low/low will shut off pumps.*
8. *Pumps must pass 3" solids. Plug valves for suction and discharge isolation.*
9. *Railings required at wet well opening. Flow meter and bypass around meter for servicing and replacement.*
10. *Night Lighting.*
11. *Spring assisted aluminum covers for wet well and valve vault.*
12. *External arm, swing check valves.*
13. *Wet well ventilation.*
14. *Hour meters for each pump.*
15. *Valve vault will be large enough for easy access for changing of valves.*
16. *J-Box for float and ultrasonic will not be installed in the wet well.*
17. *Pressure gauge and isolation valves on discharge piping with signal to unity.*
18. *Potable water.*
19. *Fencing with vector truck access.*
20. *Emergency pump connection with isolation valve and female cam-lock fitting.*
21. *All conduits will be sealed at Motor control center, wet well and valve vaults.*
22. *Proposed lift station will have emergency pump connection with isolation valve and female cam-lock fitting.*
23. *Asphalt paving/concrete pad.*

221317 RECYCLED WATER

All new construction will conform to the most recent Unified Facilities Criteria (UFC) and Code of Federal Regulation (CFR) requirements. The latest edition of the following standards shall be utilized in the order listed:

1. State of California Department of Health Services.
2. American Water Works Association (AWWA) Standards.
3. City of Oceanside Water, Sewer and Reclaimed Water Design and Construction Manual.
4. San Diego County Regional Standard Drawings.
5. Standard Specifications for Public Works Construction (SSPWC or Greenbook) latest edition.
6. State of California Department of Water Resources
7. Marine Corps Base Camp Pendleton Rules and Regulations for Recycled Water Use and Distribution (latest version)

Pipe Size and Material:

1. Note: Pipe sizes indicated are Internal Diameter (I.D.)
All recycled water mains shall be HDPE (High-Density Polyethylene Pipe). The maximum allowable velocity = 6.5 ft/s.
The minimum diameter of mains shall be 8 inches.
Service lines may be PVC class 200 (C-900).

Depth of Pipe Cover:

1. The minimum depth of cover required is 48 inches for 12-inch mains and smaller. Mains over 12 inches require special design and approval from PWO at the design stage.
Recycled water mains shall not be installed over potable water mains.

Valves and Risers:

1. Valve cans and risers shall be 6 inch PVC class 200, C-900 Pipe and colored purple.
Three valve clusters will be installed at all tee connections. Valves must be easily accessible. *Piping color is purple.*

Final Design Submittal

1. *Final Design Submittal shall print recycled water piping in purple.*

Irrigation System

1. *All new irrigation system construction shall have color purple piping and have a single point of connection.*

230000 GENERAL MECHANICAL REQUIREMENTS

1. *All Mechanical System Construction shall conform to the most recent Unified Facilities Criteria (UFC) and Code of Federal Regulation (CFR) requirements. If the standard*

sought does not appear in these requirements, then the latest edition of the following standards shall be utilized:

- a. *American Society of Mechanical Engineers (ASME)*
 - b. *American Petroleum Institute (API)*
 - c. *American Society of Heating, Refrigeration, Air-Conditioning Engineers (ASHRAE)*
 - d. *American Society for Testing and Materials (ASTM)*
 - e. *International Plumbing Code (IPC)*
 - f. *International Mechanical Code (IMC)*
 - g. *Unified Mechanical Code (UMC)*
 - h. *Unified Plumbing Code (UPC)*
 - i. *Air-Conditioning, Heating, and Refrigeration Institute (AHRI)*
 - j. *American Water Works Association (AWWA)*
 - k. *Sheet metal and Air Conditioning Contractors' National Association (SMACNA)*
 - l. *National Fire Protection Association (NFPA)*
 - m. *Underwriters Laboratories (UL)*
 - n. *American Welding Society (AWS)*
 - o. *National Board Inspection Code (NBIC)*
2. *In addition to the above requirement:*
- a. *Provide accessibility and clearance for maintenance to all mechanical and electrical equipment, machines, pumps etc.*
 - b. *All HVAC units that are installed during construction shall have all filters replaced with new filters prior to the building being turned over for occupancy.*
 - c. *HVAC Secondary condensate drain lines shall not terminate above any doorway or within 5' of the entry or exit pathways. (This is to prevent an obvious slip hazard)*

ACCESS and SERVICE SPACE:

1. *All equipment, piping and controls located in attic and mechanical room shall be easily accessible for inspection, service, repair and replacement without disabling the functionality of other adjacent equipment. Utility chases shall not be placed on or near the perimeter walls where a sloped roof interferes with access to the chase. All utility chases shall be accessible for maintenance, inspection, service, repair and replacement. Placement of equipment, piping and controls located in attics should take into consideration access from below with regard to furniture, built-ins and other equipment that could prevent a ladder from being set up under access point.*

TESTING and BALANCING (TAB):

1. *Testing and balancing consultants shall be NEBB (National Environmental Balancing Bureau) certified.*

230515 FOUR- PIPE SYSTEM FOR NEW BEQs

1. *Provide a 4-pipe reverse-return heating and cooling piping system from the Mechanical Room throughout the building vertical pipe chase, attic, and to each individual fan coil unit in each room. Provide vents at the high points of the system and drains at the low points. Drains (except BEQ fan coil units) shall be piped to a floor sink or other suitable entrance to the building's sanitary sewer system. Provide expansion loops, isolation ball valves at the drops, piping insulation, control valves, and all necessary supports, joints, couplings, caps and other items to complete the piping system. Joints on direct-bury factory prefabricated, pre-insulated copper pipes shall be silver-brazed.*

2. Provide vertical 4-pipe fan coil units and controls. Heat exchange coils shall consist of copper fins on copper tubes.

a. ABOVE-GROUND SANITARY DRAINAGE AND VENT PIPE

MATERIAL	STANDARD
Acrylonitrile butadiene styrene (ABS) plastic pipe in IPS diameters, including Schedule 40, DR 22 (PS 200) and DR 24 (PS 140); with a solid, cellular core or composite wall	ASTM D 2661; ASTM F 628; ASTM F 1488; CSA B181.1
Polyvinyl chloride (PVC) plastic pipe in IPS diameters, including schedule 40, DR 22 (PS 200), and DR 24 (PS 140); with a solid, cellular core or composite wall	ASTM D 2665; ASTM F 891; ASTM F 1488; CSA B181.2
Polyvinyl chloride (PVC) plastic pipe with a 3.25-inch O.D. and a solid, cellular core or composite wall	ASTM D 2949, ASTM F 14

b. UNDERGROUND BUILDING DRAINAGE AND VENT PIPE

MATERIAL	STANDARD
Acrylonitrile butadiene styrene (ABS) plastic pipe in I diameters, including schedule 40, DR 22 (PS 200) and DR 24 (PS 140); with a solid, cellular core, or composite wall	ASTM D 2661; ASTM F 628; ASTM F 1488; CSA B181.1
Polyvinyl chloride (PVC) plastic pipe in IPS diameters, including schedule 40, DR 22 (PS 200) and DR 24 (PS 140); with a solid, cellular core, or composite wall	ASTM D 2665; ASTM F 891; ASTM F 1488; CSA B181.2
Polyvinyl chloride (PVC) plastic pipe with a 3.25-inch O.D. and a solid, cellular core, or composite wall	ASTM D 2949, ASTM F 1488

c. BUILDING SEWER PIPE

MATERIAL	STANDARD
Acrylonitrile butadiene styrene (ABS) plastic pipe in IPS diameters, including schedule 40, DR 22 (PS 200) and DR 24 (PS 140); with a solid, cellular core or composite wall	ASTM D 2661; ASTM F 628; ASTM F 1488; CSA B181.1
Acrylonitrile butadiene styrene (ABS) plastic pipe in sewer and drain diameters, including SDR 42 (PS 20), PS 35, SDR 35 (PS 45), PS 50, PS 100, PS 140, SDR 23.5 (PS 150) and PS 200; with a solid, cellular core or composite wall	ASTM F 1488; ASTM D 2751 Asbestos-cement pipe ASTM C
Polyvinyl chloride (PVC) plastic pipe in IPS diameters, including schedule 40, DR 22 (PS 200) and DR 24 (PS 140); with a solid, cellular core or composite wall	ASTM D 2665; ASTM F 891; ASTM F 1488
Polyvinyl chloride (PVC) plastic pipe in sewer and drain diameters, including PS 25, SDR 41 (PS 28), PS 35, SDR 35 (PS 46), PS 50, PS 100, SDR 26 (PS 115), PS 140 and PS 200; with a solid, cellular core or composite wall	ASTM F 891; ASTM F 1488; ASTM D 3034; CSA B182.2; CSA B182.4
Polyvinyl chloride (PVC) plastic pipe with a 3.25-inch O.D. and a solid, cellular core or composite wall.	ASTM D 2949, ASTM F 1488

d. PIPE FITTINGS

MATERIAL	STANDARD
Acrylonitrile butadiene styrene (ABS) plastic pipe in IPS diameters	ASTM D 2661; ASTM F 628; CSA B181.1
Acrylonitrile butadiene styrene (ABS) plastic pipe in sewer and drain diameters	ASTM D 2751
Polyvinyl chloride (PVC) plastic in IPS diameters	ASTM D 2665; ASTM F 1866
Polyvinyl chloride (PVC) plastic pipe in sewer and drain diameters	ASTM D 3034
Polyvinyl chloride (PVC) plastic pipe with a 3.25-inch O.D.	ASTM D 2949

230900 DIRECT DIGITAL CONTROL SYSTEMS

GENERAL REQUIREMENTS

1. The use of Sections 013513 SPECIAL PROJECT PROCEDURES should be considered to cover migration of facilities already constructed using Base Wide Energy Management System (EMS) Technical Design Specification. All new and/or renovated facilities shall be designed for EMS connectivity based on the technical requirements specified in Specification (15910), Direct Digital Control System dated 1 Mar 06. Future Versions of this document will be based on UFC 3-410-02. *UFGS 2309.23 Lon works based DDC for HVAC and UFGS 2309 53 .00.20 Space Temperature Control Systems (reference specification below).*
2. Energy Management System (EMS) LON control devices shall be LonMark Certified utilizing a LonWorks Network Services (LNS) based database structure. Configuration parameters of the LonMark certified devices shall be directly accessible via an LNS based application interface (plug-in). The "plug-in" shall be installed and its use demonstrated with Commercial off the Shelf (COTS) LNS management tool. The "plug-in" shall be freely available and/or provided by the installing contractor.
3. The system shall be of a flat, open architecture and the devices shall communicate utilizing the ANSI/CEA 709.1b (LonTalk) Protocol and CEA 852. Installed LON networks shall be readied for connection to the existing base wide MCB Camp Pendleton EMS system (Unity) utilizing the most feasible and economical option available including; hardwire (709.1b) connection to existing Facility Management System Cable (FMS Cable), network drop (CEA 852) located in NMCI/Telco Room, wireless LonWorks router (709.1b), and/or wireless network (CEA 852) connection. It is recommended, as part of project design that the Direct Digital Control System submittals be turned into the Unity Room Manager or Representative separately for approval.

REFERENCE SPECIFICATION - SECTION 230900 (15910CP) DIRECT DIGITAL CONTROL SYSTEMS 03/06, Section 2309 23.13.20

231110 ABOVE GROUND STORAGE TANKS

1. All new ASTs on MCB CPEN must meet the following 40 CFR 112.7, CPEN Fire Marshall, and AC/S, Environmental Security requirements:
Double Wall secondary containment, UL 142 listed for combustibles, UL 2085 listed for flammable liquids.
2. AST secured by mechanical fasteners to a reinforced concrete pad approved by the tank manufacturer.
3. High level alarm (better or equal to TM1 Tank Monitor).
4. Secondary space leak gauge (better or equal to At-A-Glance Leak Gauge).
5. Primary tank level gauge (better or equal to At-A-Glance Direct Reading Gauge).
6. Fill line spill bucket container (better or equal to Pomeco 221-AST Spill container, min. 5 gallons).
7. NFPA 704 markings (fire diamonds).

8. Vehicle collision protection (concrete-filled steel pipe bollards) spaced in accordance with manufacturer's recommendations.
9. All piping *must be aboveground and visible (single wall), **unless approved prior to construction by Environmental Security and Public Works Office because of extenuating circumstances. Any underground piping must be double-walled and electronically monitored***.
10. Piping must be painted, labeled for product contained and direction of flow indicated by arrows.
11. Gasoline tanks 250 gallons and greater require an Air Pollution Control District Permit.
12. Camp Pendleton Fire Dept. (Fire Marshal), AC/S, Environmental Security (NEPA and Spill Prevention Branches) and AC/S O&T, OPS Force Protection must approve tank site plans prior to installation.

234100 NATURAL GAS REQUIREMENTS

GENERAL

1. *Prior to any construction of a natural gas utility connection, all construction plans for a natural gas system service connection shall be submitted to and approved by Public Works Utility Team and/or FMD Natural Gas Technicians. FMD Natural Gas Technicians shall be present to inspect and approve the pre-connection, installation, and post connection, in order to ensure compliance with standards set forth within these requirements.*
2. All natural gas system construction shall conform to the most recent *NFPA 54*, Unified Facilities Criteria (UFC) and Code of Federal Regulations (CFR) Title 49, Part 192 requirements. If the standard sought does not appear in these requirements, then the latest edition of the following standards shall be utilized in the order listed:
 - a. International Fuel Gas Code.
 - b. American Society of Mechanical Engineers, ASME.
 - c. American Society of Testing Materials, ASTM.
 - d. *Unified Facilities Guide Specifications, UFGS*
 - e. San Diego Gas and Electric Specifications and standard construction details (will require Public Works approval).
3. *In addition to the preceding codes, the contractor shall ensure the following items are adhered to during design and construction phases:*

STANDARD CONSTRUCTION DETAILS:

1. *All natural gas piping layouts including shut-off valve and excess flow valve (EFV) locations shall be submitted to PWO/ROICC for approval.*
2. *All pipe shall be buried a minimum of 36" below finished grade or as recommended by the manufacturer, whichever is greater. Any burial of pipe less than 36" will require Public Works approval.*
3. *Tape an insulated yellow #10 AWG polyethylene coated tracer wire to the top of the pipe that terminates a minimum of 4" above grade at all metal vertical risers. Do not wrap the wire around pipe. All tracer wire connections must be water tight.*

4. *All buried piping shall include magnetic warning tape installed 12" below finished grade. The tape shall be 3" wide and shall have the words "Caution buried gas line below" or similar.*
5. *All coated anode less vertical risers and aboveground pipe shall be black steel schedule 40 or 80 in non-coastal areas and galvanized piping in coastal areas. Pipes 2" and smaller should have threaded ends. Pipe greater than 2" shall be butt welded in accordance with ASME standards. Provide galvanized piping on regulator/meter assemblies in coastal areas.*
6. *All aboveground pipes and components shall be cleaned to Society of Protective Coatings (SSPC) 2 or 3, primed per Master Painters Institute (MPI) 23 then painted using an intermediate and top coat meeting MPI 94. The paint shall be identifying natural gas color yellow per the American Public Works Association (APWA) uniform color code. However, if a component is already factory primed and painted, do not prime or paint.*
7. *All aboveground piping shall have proper labeling per ASME.*
8. *Contractor shall provide an aboveground pressure regulator/meter detail as part of the construction plan set for PWO approval. The detail shall include components identified in regulator/meter detail below.*
9. *Only pre-engineered traffic rated valve canister assemblies for valves will be accepted by PWO/ROICC. The top cover shall be painted with the natural gas identifying color yellow per APWA uniform color code. All excess flow valve box covers shall be molded with the letters "EFV" in the center of the cover and all shut-off valve box covers shall be molded with the word "GAS" in the center of the cover. The top of the valve box cover shall be flush with grade and easily accessible. Valve boxes in unpaved areas shall have a 12"x12"x4" reinforced concrete pad around them.*
10. *For below-ground fitting, all fittings shall be hot-fused, no flanges or threaded fittings are allowed. For above-ground fittings, the contractor shall use soft-set type natural gas thread sealant (pipe dope).*
11. *All natural gas connections to the distribution system shall be approved by PW Utility Team prior to connection and the proper FMD personnel shall be present during the connection. For approval, designer must provide drawing detailing the location, method of connection, and load calculations proving that new line will be able to support the new and existing buildings. The contractor performing the connection shall have an up-to-date polyethylene fusion card and show this to the FMD Natural Gas Technician to perform the connection.*
12. *Before purge a natural gas line, the contractor shall provide AHA's and site specific purge plan to ROICC (or Government representative in charge of construction) for approval. Contractor performing the purging shall fulfill the certification requirements of the AHJ and purging shall only be performed by a qualified agency as per NFPA 54-17. All purging must follow CFR 49 Part 192 and ASME Purging of Pipelines and Mains. All abandoned lines shall be purged with nitrogen and be checked for percentage gas with a meter at purge point.*
13. *New gas lines located in vegetated areas, away from paved areas shall have pipeline markers indicating the presence of the lines. Contractor shall place markers at or near taps, tees, caps, and at 500' intervals along natural gas lines. Final placement of pipeline markers is subject to field conditions; Contractor shall use discretion to ensure appropriate line of sight is established with pipeline markers, gas representative may determine the need for additional pipeline marker installations.*

MATERIALS

1. *All gas pipeline products shall be Polyethylene PE2708 for distribution or PE4710 for transmission, and shall be of Standard Dimension Ratios (SDR) 11 minimum. SDR calculations or material specifications shall be submitted and approved by PW Utility Team prior to ordering material.*

MAIN LINE TIE-IN CONNECTION & BRANCH CONNECTIONS

1. *A main line tie-in shall include an HDPE or PE shut-off valve and an excess flow valve (if EFV is approved) located in valve boxes. There shall be at least 18" distance between the shut-off valve and the excess flow valve All valves shall have a 2" operating head minimum.*
2. *All gas branches of runs of over 10 feet shall have a shut off or isolation valve installed at the branch connection.*
3. *Where a pipe branch is supplying gas to a Fireplace or any other type of a gas appurtenance and the appurtenance is farther than 10 feet from the branch tee an approved gas "shut off" valve shall be installed at the branch tree to isolate gas supply to the branch pipe.*
4. *Whenever a factory-built fireplace or gas appurtenance is installed the gas "shut-off" valve shall not be concealed and shall be accessible to shut off the gas supply to the appurtenance from the exterior with the use of the gas valve key.*
5. *Where an outdoor BBQ is installed it shall be required to have access to all gas connections from under the BBQ unit and at no time shall the gas flex and service valve be hidden. An emergency shut off valve shall be installed near the adjacent building.*
6. *Where a union is used on a gas line supply branch, the branch shut off valve shall be upstream of the branch union at all times.*

REGULATOR/METER ASSEMBLY (reduces pressure for one building)

1. *A regulator/meter assembly (or building riser assemblies) shall include a PE to steel anode less transition (with epoxy coated steel, 36" long minimum and tape fastener), gas cock with lock ring, black oxide-coated dielectric union rated for natural gas, in-line fill-pot filter with proper micron size and rated for natural gas, plugged test tee with gas cock, pressure regulator, ball valves, meter, supports, plugged test tees, and earthquake valves.*

REDUCER STATION/MASTER METER STATION (reduces pressure for several buildings or a whole cantonment area/meters gas flow for whole cantonment area)

Reducer stations shall include the following components and adhere to the following requirements:

1. *Primary Reducing Station line and a secondary bypass Reducing Station line for providing maintenance to the station with continuous reduced pressure service to the area.*
2. *Two reducing valves in series on both the primary and bypass line. The reducing valves must be sized to accommodate the entire load that it is reducing the pressure for as well as a percentage to accommodate for future loads.*
3. *A meter.*

4. *A relief valve, gauge, and pressure tap on either side of reducing valves. Relief valves are not necessary if the reducing valves have built-in relief valves.*
5. *In-line fill-pot filter with proper micron size and rated for natural gas.*
6. *Below ground shut off valve before PE to steel transition. Shut-off valves to isolate reducer station lines and components.*
7. *Supports for heavy components/equipment.*
8. *Transitional flanges must be a minimum of 4" above grade and pipe risers should be primed and wrapped with grease/wax tape, bubble wrap and 20 mm gas tape.*
9. *Install a reinforced concrete pad foundation, minimum 6" thick and a minimum of 3,000 psi.*
10. *Install an 8 foot tall fence with a barbed wire top guard around the reducer station. The fence posts shall be in the concrete slab with a sleeve. Fence shall be grounded and bonded and shall have a lockable double swing gate entrance.*
11. *Install metal beam guard railing around reducer station with flared end, steel posts, notched steel blocks, and guard rail reflectors.*
12. *A master meter station requires all of the above items except for the reducing valves and bypass line.*
13. *All aboveground piping shall have yellow directional flow arrows per ASME.*

235200 BOILER REQUIREMENTS

GENERAL:

In order to meet the federal energy efficiency requirements and MCB Camp Pendleton energy reduction mandates, boilers used on Camp Pendleton facilities shall be of highest efficiency, best technology available, and meet the Federal Acquisition Regulation Subpart 23.2 for Energy and Water Efficiency and Renewable Energy, Authorizing law and regulations for FAR 23.2 are listed below:

23.201 Authorities:

- a. *Energy Policy and Conservation Act (42 U.S.C.6361(a)(1)) and Resource Conservation and Recovery Act of 1976 (42 U.S.C. 6901, et seq.).*
- b. *National Energy Conservation Policy Act (42 U.S.C.8253,8259b,8262g and 8287).*
- c. *Section 706 of Division D, Title VII of the Omnibus Appropriations Act, 2009 (Pub. L. 111-8).*
- d. *Title VI of the Clean Air Act, as amended (42 U.S.C.7671, et seq.).*
- e. *Executive Order 11912 of April 13, 1976, Delegations of Authority under the Energy Policy and Conservation Act.*
- f. *Executive Order 13423 of January 24, 2007, Strengthening Federal Environmental, Energy, and Transportation Management.*
- g. *Executive order 13514 of October 5, 2009, Federal Leadership in Environmental, Energy, and Economic Performance.*

BOILER REQUIREMENTS

1. All boilers used for heating hot water shall be fire tube/fire box type boilers *utilizing the best energy efficient technology available for this type of boiler*. The boilers must have IRI gas train and meet CSD-1 compliance.
2. *The usage of condensing boilers will be allowed as long as the following parameters are met:*
 - a. *The original design of the entire heating system should be designed to use condensing boilers. The mechanical design must not be a "fire tube/fire box" design system with a condensing boiler "plugged in" as a substitution. The implication of that would be that the distribution piping and pressures would not be adequate to support a condensing unit. The intent being to avoid constructing distribution piping with inadequate pressure to support a condensing unit.*
 - b. *The system must run at a temperature of 130-140 degrees maximum on supply, and 100-110 degrees return in a low temperature loop.*
 - c. *All condensing water heaters and boilers will have a neutralizer in the stack drain prior to entering MCBCP waste water piping.*
 - d. *The design must be for 100% occupancy.*
 - e. *The system should run at approximately 50psig operating pressure for a five story building.*
 - f. *In order to maximize energy efficient usage of the boilers, they should be set up as a series of smaller, modular units which meet total demand load; but, which can be programmed for staging individual unit activation as the demand load increases.*
 - g. *The Final Submission documents will be reviewed by FMD and the Energy Office for their compliance with the parameters listed.*
3. Domestic water boilers under 140 deg F may be fin tube water tube boilers. The boilers must have IRI gas train and meet CSD-1 compliance.
4. Any new unit (boiler, process heater, or steam generator) with a heat input rating of 1million Btu per hour or greater may require an Air Permit.
5. *When acquiring energy-consuming products listed in the ENERGY STAR Program or Federal Energy Management Program (FEMP), agencies shall purchase ENERGY STAR or FEMP-designated products.*
6. *Per Energy Star recommendations, boilers shall have an Annual Fuel Utilization Efficiency of 85% or better.*
7. *The heating hot water supply system for swimming pools' water shall have a "double wall" heat exchanger installed, instead of the standard "single wall."*

235233 LOW PRESSURE WATER HEATING BOILERS (OVER 400,000 BTU/HR OUTPUT)

Only used DDC (Direct Digital Control) System for FMS and Heating System instead of pneumatic control and with separate over ride switches for all equipment being controlled by Unity Room. All remote operator communication (by others) shall be through connection to the existing Camp Pendleton Facilities Management System (FMS) with connectivity to the

“UNITY ROOM”.

1. Boiler submittals to be approved by FMD Boiler Inspector.
2. Only install “Hurst” fire tube firebox heating boiler or equal in compliance with the enclosed Section 235233 (edited) specifications acceptable to *the government*.
3. Boiler isolation valves shall be ball valve or gate outside screw & yoke design and flanged ends valves and **be installed closer to the boiler.**
4. Boiler gas trains must comply to I.R.I gas control system with Honeywell RM-7800-L-1012 (Infrared scanner) for flame safeguard control panel. Gas train must have leakage test valves installed as per ASME CSD-1-2004 para. CF-150 (d).
5. Boiler vents (forced draft) must comply to positive pressure type for boiler stacks.
6. Ensure McDonnell & Miller Test N Check Valves Model #TC-4 is being installed on low water control piping.
7. *Provide* quick disconnect switches for on each boiler at each entrance door properly labeled for identification. If there is more than one door to the boiler room, there should be a switch located at each door as per ASME CSD-1-2004 para. CE-110 page 9 and CF-310 (d) page 21.
8. Ensure Boiler Burner Combustion Flame Safeguard system shall be provided with a **repetitive self-checking circuit.**
9. Ensure boiler control panel cabinet is remotely mounted either on the side of the boiler or on the wall away from boiler burner front, and is installed so that the alarm lights on the cabinet are located approximately 4 to 5 feet above floor.
10. Ensure two separate vent lines are being installed for gas train normally open vent valve and for gas diaphragm pressure switches/gas pressure regulator.
11. *Provide* drip legs on each boiler gas train as per CSD-1 para. CF0-140 page 17.
12. *Provide* union fitting on boiler relief valve discharge line.
13. Ensure where electrical components and devices are subject to dripping moisture/water shall be provided *in a weatherproof/driptight enclosure.*
14. *Provide* cement lined for domestic hot water storage tank instead of glass lined. (For easier weld repairs).
15. Per UPC (Uniform Plumbing Code) 603.4.4 only double wall heat exchanger *is permitted* on cement lined domestic hot water storage tank.
16. Only install Chemical Pot Feeder with “legs”, (5 gallons capacity) with maximum pressure/temperature of 200 psig/200F.
17. Ensure piping insulation and equipment are identified, labeled and marked for direction of flow.
18. Per “Closeout Procedures” ensure “Warranty Tags” are being attached on each newly installed equipment/product. Furnish with each warranty the name, address, and telephone number of the guarantor’s representative nearest to the location where the

equipment and appliances are installed. The guarantor's representative, upon request of the station representative, shall honor the warranty during the warranty period, and shall provide services prescribed by the terms of the warranty.

19. Due to the hard domestic water at Camp Pendleton, *provide* "Type K" of copper tube for all domestic and heating water above ground piping to reach a life expectancy of 20 years.
20. *Provide* a thermometer on all domestic storage tanks. The thermometer shall at all times indicate the temperature of the water in the tank at or near the outlet.
21. Provide and install "Guard Post" (4" Sch. 80 Steel Pipe filled with concrete and paint with brilliant yellow) where the gas meter and or regulator may be subjected to "vehicular damage".
22. Automatic air vent valve shall be equipped with a vent line running to the floor.
23. Ensure circ pumps are not installed overhead to facilitate repairs without using a step-ladder.
24. Ensure main gas line in the boiler room is being installed overhead to prevent trip hazard to the personnel.
25. *Provide* ½" hose bib connection in the boiler room for performing Boiler *Preventative Maintenance*.
26. Our procedures for certification of boiler are:
 - a. First witness 150% hydrostatic test of 1 ½ times of the boiler highest safety valve popping pressure or 1 ½ times of the boiler MAWP, whichever is less. (To determine if leakage causing damages have occurred during shipment/installation.)
 - b. Received documentation of boil-out of boiler for each boiler.
 - c. Received combustion tests report of boiler for each boiler.
 - d. Received documentation to show newly installed boilers have had the HHW systems chemically treated.
 - e. Witness operational tests of all boiler safety controls.
 - f. Received Boiler Manufacturer Data Report Sheet and Manual for each boiler. (Form H2/H3 for ASME Section IV) or (Form P2/P3 for ASME Section I)
27. Any new unit (boiler, process heater, or steam generator) with a heat input rating of 1 million Btu per hour or greater may require an Air Permit.
28. Chemically treated pool water shall not make contact with the boiler tubes.
29. *Where water pressure is in excess of 80 psi, an approved type pressure regulator, preceded by an adequate water strainer, shall be installed to reduce the static water pressure to 80 psi or less as per UPC 608.2.*
30. *Covers shall be provided over trip hazards to protect personal, as per OSHA 1910.22(C) requirements.*
31. *Where the word "should" is used in the manufacturer's recommendations, substitute the word "shall".*
32. *All manually operated gas shut off valves shall be of the T-handle or lever-handle type and shall be operable without the use of tools, as per CSD-1 CF-150.*

33. *The pressure differential between the relief valve set pressure and the boiler operating pressure shall be at least 10 psi or 25% of the boiler operating pressure, whichever is greater, per NBIC Appendix F, F-2000.*
34. *Eyewash stations shall be installed in all mechanical rooms containing chemical pots.*
35. *All boiler rooms over 500 square ft. containing one or more boilers having a combined fuel capacity of 1,000,000 Btu/hr or more shall have two means of egress, as per NBIC Part One, section 3.4.1.*
36. *Heating boilers shall have a minimum of 36" of unobstructed clearance around all sides and above the boiler, as per NBIC part one, section 3.3.4.a.*
37. *Boiler isolation valves shall not be used as throttling valves.*

260400 ELECTRICAL REQUIREMENTS

GENERAL

1. All electrical system construction shall conform to the most recent Unified Facilities Criteria (UFC) and Code of Federal Regulation (CFR) requirements. If the Standard sought does not appear in these requirements, then the latest edition of the following Standards shall be utilized in the order listed:
 - a. National Electrical Code.
 - b. San Diego Gas and Electric Specifications and standard construction details.
2. Before any digging or disturbing in any location, the contractor shall be responsible to coordinate with the Base Environmental Security Office for permit and /or inspection.
3. *Electrical utilities shall be installed underground in new construction projects, unless excepted by approval of the Base Public Works Electrical Engineer.* All underground conduit ducts for site and secondary power, telephone, cable and low voltage service cables shall be minimum PVC 40 concrete encased. Concrete shall have a minimum 3,000 psi compressive strength and contain red color dye added to the concrete mix.
4. All trench ground wires shall not be installed with other medium voltage class cables in conduit(s), but rather shall be installed in the duct bank concrete encasement.
5. Overhead electrical utilities shall be constructed in accordance with San Diego Gas & Electric Standards, SDG&E Section 1600 for Avian Protection.
6. The contractor shall be responsible to apply and pay costs for all new San Diego Gas & Electric (SDG&E) service requirements.
7. All wet type transformers and switches shall have less-flammable liquids. NFPA 70 and FM P7825 for less-flammable liquids having a fire point not less than 300 degrees C tested per ASTM D 92 and a dielectric strength not less than 33 kV tested per ASTM D 877. The fluid shall be a biodegradable electrical insulating and cooling liquid classified by UL and approved by FM as "less flammable". Fluid properties shall meet pour point ASTM D 97, less than -15 degree C, aquatic biodegradation EPA 712-C-98-075, 100% and trout toxicity OECD Test 203, zero mortality of EPA 600/4-90/027F, pass.
8. No live-front padmount switches or transformers will be permitted.
9. SF₆ gases are not permitted.

10. *A complete set of spare fuses shall be provided for all medium voltage oil-filled switches and transformers.*
11. *When installed within five miles of the ocean: All outdoor electrical equipment such as switchboards and panels, padmounted switches and transformer enclosures must be stainless steel NEMA 4x and comply to ANSI c.57.12.29 for coastal environments.*
12. Pad-mount transformers shall contain stainless steel bases to minimize corrosion where subject to landscape irrigation or standing water.
13. All substations and switchboard circuit breakers which are removable shall be provided with mechanical hoist; circuit breaker carts and storage cabinet in the same area as *the* substations switchboard. Where application is outdoor, carts provided shall be made of stainless steel.
14. Electrical Meters, see SECTION 220519 BASE UTILITY METER REQUIREMENTS.
15. Electrical design shall comply with Commercial building design standards and practices to allow for the traditional approach in determining the distribution system panel and feeder size/ratings based on a more conservative demand-adjusted connected load to better accommodate surges or future load growth.
16. All electrical switchboard and panelboard buses shall be copper.
17. All panelboard circuit breakers shall be bolt-on type. Include a main circuit breaker *or switch* in every electrical subpanel.
18. Electrical panel phases/loads shall be reasonably balanced within normally accepted tolerances, standards or guidelines.
19. Panel schedule shall show all connected loads per phase.
20. All service, feeder and branch circuit wiring shall be copper.
21. (MC) Metal-Clad Cable is not permitted.
22. Use steel compression connectors and couplings on EMT conduit.

All abandoned conduits and pipes shall be properly filled and capped at all vaults, hand holes, and junction areas
23. Receptacles shall be minimally rated heavy-duty, specification, commercial or premium grade.
24. Outdoor LED Luminaires shall be American-made, ARRA Compliant at least 1 year of commercial service, listed to UL 1598, tested to LM79 & LM80, have an efficacy > 50 lumens/watt, L70 life > 75,000 hours, CRI > 70, CCT < 6500 and IP rating > 54 with onboard surge protection and with a minimum 5 year light engine/ enclosure coating warranty. Color temperature range for outdoor LED lamps shall be from 4000K to 6000K. Roadway luminaries shall comply with DOE LED roadway spec version 1.0 dated Oct 2011, have area cutoff to minimize glare and/or comply with existing installed LED fixtures approved by Base Energy office/PW.
25. Light fixtures for parking lots *and canopy lighting shall be LED, induction or have 49-watt T-5 HO (High Output) fluorescent lamps and electronic ballasts that meet Base Requirements and item 24 above for LED.*

26. Wall packs shall be *LED* or induction type with individual photo or *Base EMS* control unless otherwise authorized to be (HID) High Intensity Discharge type by the Public Works Electrical Engineer specifically for high security or special illumination applications. HID installation must be approved by PW.
27. Light fixtures located in Hi-Bay applications shall be 49-watt T-5 High Output fluorescent lamps and electronic ballasts.
28. Egress Lighting Illumination Level shall be a minimum of one footcandle along the path of egress. Egress Lighting Photometric study is required.
29. *“Emergency light self-contained wall-pack or ceiling (or separate head) units shall contain LED light source for lower battery/power consumption and reduced maintenance costs.*
30. Compact fluorescent twin-tube or quad lamps shall be horizontally mounted where installed in recessed or surface downlight open-can fixtures for better, glare-free illumination.
31. Four-foot fluorescent fixtures shall be provided with 25-watt Super T-8 fluorescent lamps and electronic ballasts with NEC required quick disconnects.
32. Color temperature of fluorescent lamps shall normally be 4100 (indoors) to 5000 (outdoors) degrees Kelvin for most applications except where other color temperatures can be reasonably justified for specific purposes when color rendition is of prime importance. Color temperature for interior LED lamps shall be 3500 K to 4100 K.
33. All steel light poles shall be powder coated inside and out.
34. *All exterior light poles shall have dry-pack grout at base. All poles that are not direct bury type shall be securely tightened down on anchor bolts. Dry-pack non-shrink mortar (grout) shall be placed under the pole base plate, base casting (where applicable), and around the conduits and ground rod, and shall have a 1/2-inch diameter drain hole located at the low point to prevent water accumulations in the base. Grout shall fill all voids under the base and shall be neatly finished where exposed. Excess grout shall be cleaned from the base casting before painting and none shall show on painted surfaces. Dry-pack nonshrink mortar shall consist of a 1:3 mixture of cement and fine sand with just enough water so that the mixture will stick together when molded into a ball by hand and will not exude moisture when so pressed.*
35. *Where new conduit is specified to be installed in existing foundations, the conduit shall be installed by carefully cutting a slot in the foundation avoiding rebar reinforcement, installing the required conduit and patching the opening with grout.*
36. All system-circuited street, walkway, security and parking lot lighting fixtures shall be provided with individual fusing to locally isolate internal fault-caused loss of power from affecting the remainder of the branch circuit lighting.
37. Time switches shall be digital electronic type with battery back-up and shall contain astronomic or photocell control feature where used for operating lighting.
38. All old style BEQ lighting designs that do not contain a vestibule entry or hallway with separate localized illumination, but rather have entry directly into the sleeping room with a bright main light fixture over the sleeping area, shall incorporate a low-wattage compact fluorescent night light inside the main fluorescent light fixture that provides minimal lighting in sleeping area. The night light shall be separately switched from the main light and the

switch shall be located at the entry door. The main light switch should be located near the hallway to the bathroom to avoid accidentally switching-on the main light upon sleeping room entry.

39. All dimmer or fan speed controls shall contain a separate "on/off" switch to allow for preset dimming or fan speed without losing the adjusted setting when the lights or fan are turned "on" or "off". The separate switch is usually more durable and has a longer operational life than continually moving the slider control for switching power "on" or "off".
40. A molded case main switch may be installed in lieu of a main circuit breaker in an electrical subpanel as a disconnecting means where feeders are protected by a properly sized circuit breaker installed in the switchboard or panelboard immediately upstream of the affected subpanel. Provide a label adjacent to the main switch for identification to avoid possible confusion with the main circuit breaker that may be located elsewhere.
41. *Basewide bonding is required of all 12 Kv overhead pole line construction.*
42. *All "at and below" grade connections of bare grounding to be of the exothermic weld type of connection to include splicing and terminations.*

PHOTOVOLTAIC SYSTEM

All new Photovoltaic (PV) systems installed at Camp Pendleton shall comply with the following requirements:

1. PV system rated 30 kW and larger must have San Diego Gas & Electric (SDG&E) meter, base meter, and 3rd party California Energy Commission (CEC) approved data acquisition verification systems. Each Data Acquisition System (DAS) will come with a 5 year agreement with the respective contractor and is paid for by the project contractor. Photovoltaic System less than 30 kW will require SDG&E meter and Base meter. All meters will meet current Base specifications for Advanced Metering Infrastructure (AMI) electric meter.
2. For solar thermal systems, all arrays will include a British Thermal Unit (BTU) meter that constantly monitors solar BTU contribution to respective building, equipment or training pool. BTU meters will have communication capability to communicate in real time with Building Automation System and report back to Unity or Hub.
3. The selected site shall not contain elements that cause shading of the array during daylight hours.
4. For roof-mounted PV array, the roof dimension must be used to establish a ratio that will make the building aesthetically pleasant.
5. *The PV array surface to be desoiled by the contractor during the last half of the warranty period.*
6. Roof-mounted PV arrays shall have vertical and lateral air flow along the back surface of the modules.
7. All fixed position PV systems must have the following orientation:
 - a. The azimuth and tilt angles are equal to 195° and 33°, respectively. This is predicted to optimize the system to collect annual energy that is site specific to Camp Pendleton.
 - b. In situation where the orientation in part (a) is not a viable option, the azimuth and tilt angles can be selected from the ranges of 170° - 210° and 20° - 40°, respectively. Attempt must be made to select an orientation that is near the

optimum azimuth and tilt angles. It is predicted that approximately 3% or less reduction in annual energy collection should be achieved when the selected orientation stay within the azimuth and tilt angle ranges.

8. *All new construction shall provide signage and placards with the new PV system with regard to primary metering, sub stations of power sources and disconnects. The information on any existing signs and placards to be incorporated into the new sign/placard and all of the old signs/placards to be removed so that only the one new sign/placard remains.*

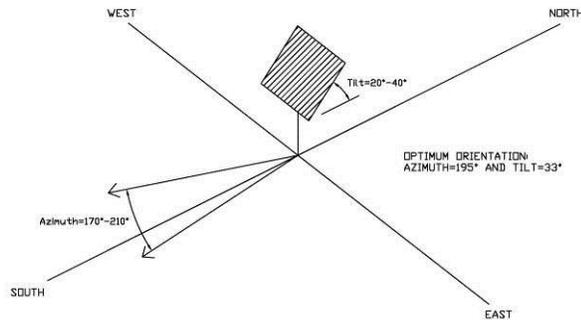


Figure 1: Array Orientation

The estimated orientation requirement is based on the analysis of a made-up 100 kW PV system situated in San Diego. PVWatt software that was provided by the National Renewable Energy Laboratory (NREL) was used to acquire the data. Below are two figures that depict PV Watt outputs for the system. Due to marine layer that is prevalent in southern California, the azimuth is observed to have been shifted.

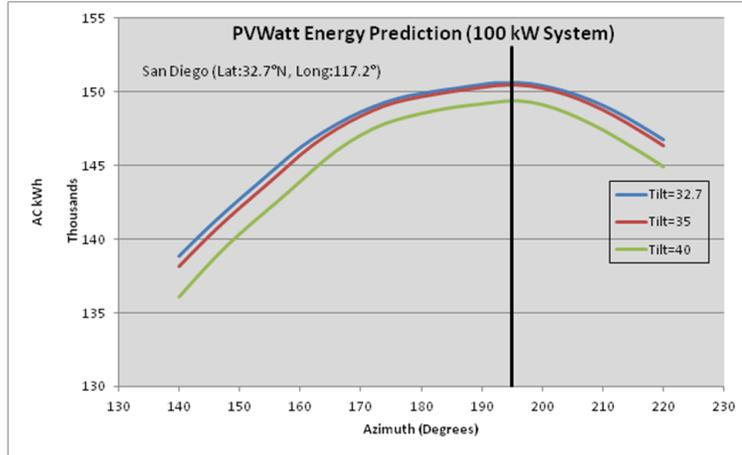


Figure 2: Annual Performance as a Function of Azimuth Angle

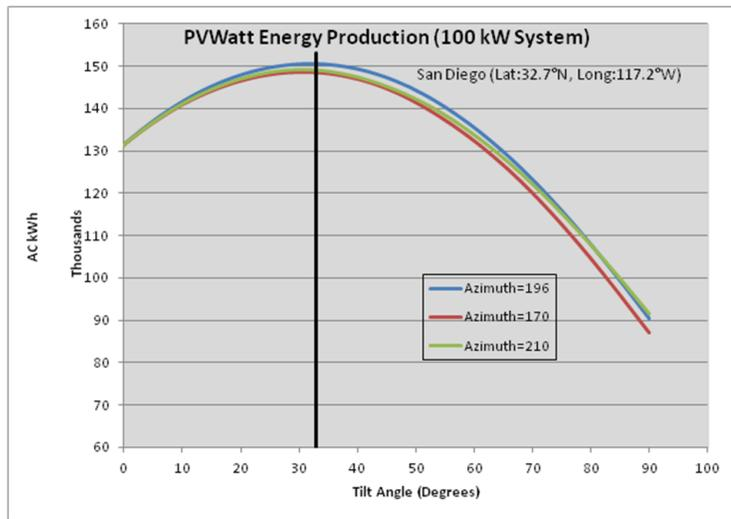


Figure 3: Annual Performance as a Function of Tilt Angle

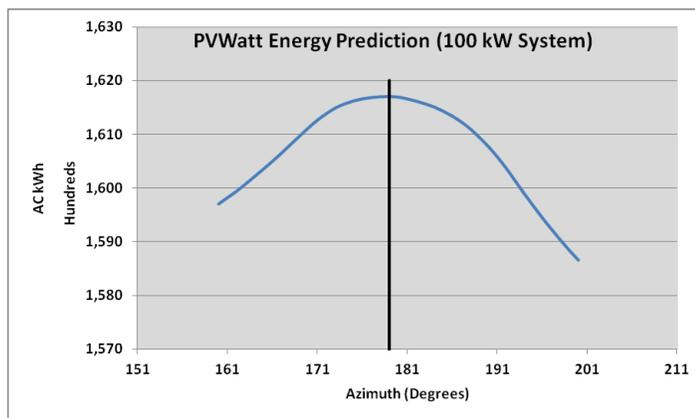


Figure 4: Made-Up System in Phoenix

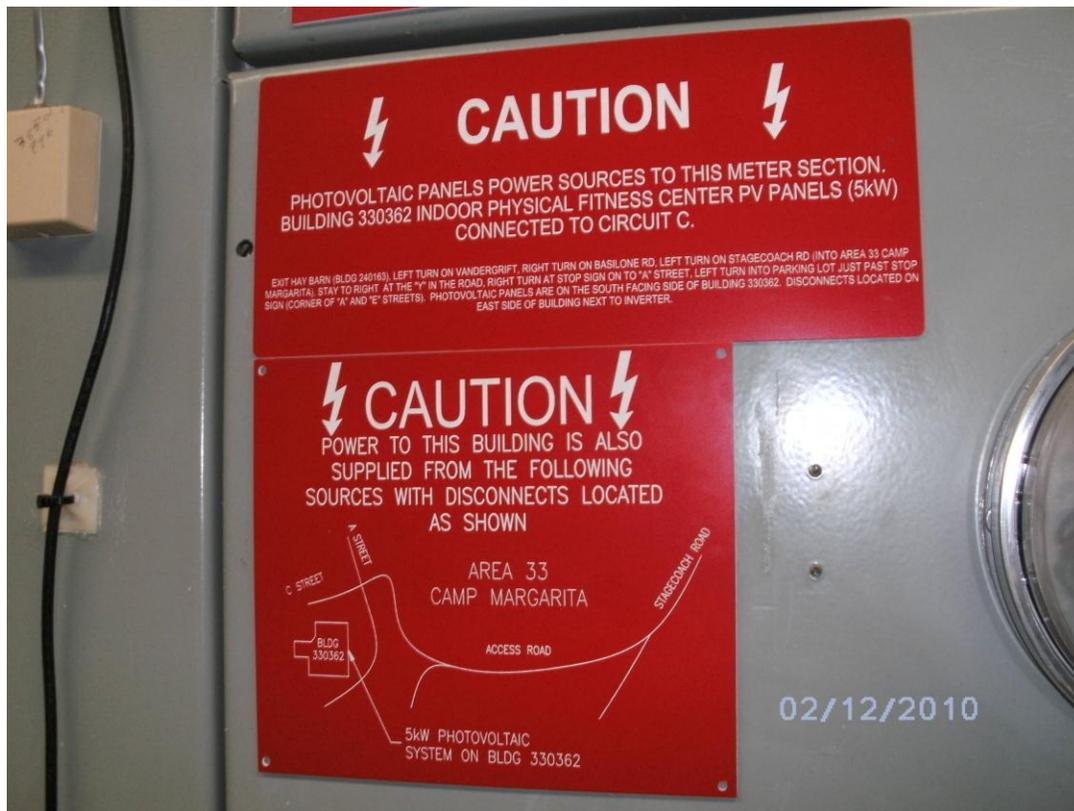
- No marine layer in Phoenix so best azimuth is dead south at ~180 degrees.

PHOTOVOLTAIC, SOLAR THERMAL, FUEL CELLS AND OTHER GENERATION TECHNOLOGIES

NOTE: Reference Photovoltaic Specs in Section 260400 Electrical Requirements

1. Currently there are no requirements in place to address the installation of certain renewable generation, co generation and solar thermal technologies aboard Base. The Energy Office has been involved in a number of installations in the last few years and has been able to include requirements during project development. With the advent of MILCON projects installing these same systems it is evident that a more structured approach with specific project requirements be available to contractors during the RFP stage to ensure that all new generating systems are functioning as intended while meeting the Camp Pendleton requirements.

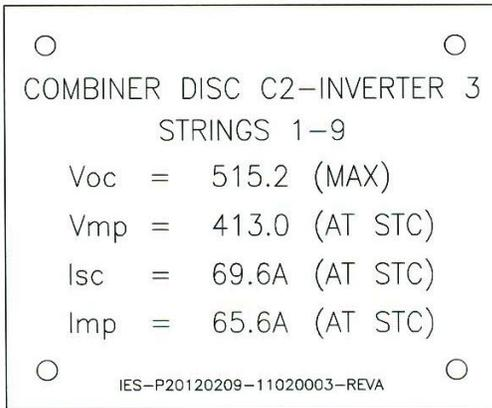
REQUIRED PHOTOVOLTAIC SIGNAGE EXAMPLES (see also SDG&E signage standards)



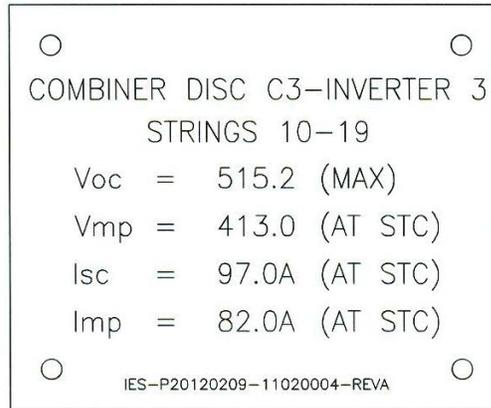
DESCRIPTION OF PLACARD:

- **FONT SIZES ARE IN INCHES FROM LARGEST TO SMALLEST AS FOLLOWS:**
 - A. 1/4 TITLE**
 - B. 1/8 CONTENT**
- **PLACARD COLOR WILL BE RED ON FRONT WITH WHITE LETTERING ENGRAVED**
- **MOUNTING HOLES ARE 1/8” DIAMETER THRU 1/4” FROM EACH EDGE TYPICAL AT ALL 4 CORNERS**
- **BREAK ALL EDGES, CHAMFER AND DEBUR**

LOCATION:
COMBINER 1



LOCATION:
COMBINER 2



REQUIRED LOCATIONS FOR SIGNAGE:

1. Combiner box w/integrated disconnect.
2. Existing switchboard near main service disconnect.
3. Main Meter, AC Disconnect, Main Switchboard or near points of interconnection.
4. CGOM
5. Inverter
6. DAS Environmental enclosure.
7. DAS Communications enclosure.

263213 DIESEL GENERATOR REQUIREMENTS

1. Generators need to be permitted through SDAPCD for the majority of the Base and SCAQMD for equipment located in the 64-area (Talega).
2. The contractor shall complete the application in the name of Camp Pendleton (CPEN) and pay for the application costs. The ES/Air Branch MUST review and approve the application prior to submitting to SDAPCD. This process takes at least 6 weeks and could take as long as, 6 months. Submit the application ASAP - even if it means submitting without knowing specific engine information, such as, engine serial numbers.
3. All new diesel engines for (CPEN) are to be Tier 3 certified, when available. The actual emission standards required for the engines depend on the size of the engine as follows:
4. All equipment greater or equal to 50 HP requires a permit from local air district. The State of California developed requirements specifically for diesel engines that required certain emission standards. These Standards have been categorized into "Tier" Standards. In the near future, all diesel engines will be meeting at least Tier 3 standards. For this reason, all new diesel equipment shall meet Tier 3 emission standards when available. This allows future flexibility for the Base to use the engine, if needed and it helps in reducing the Base's emissions, which are annually monitored and reported to the district for use in regulating the Base.
5. If the engine is used to provide emergency back-up power, then there typically is a self-imposed limit on the number of allowable non-emergency operation hours of operation (i.e. testing/maintenance usage). If the generator provides back-up power to a critical unit - it is typically 30, 50, or 52 hours. If the unit provides non-critical back-up power, then hours are limited to 20. The regulation still requires that Tier Standards are met according to the engine size. The reference that outlines these requirements can be found at: <http://www.sdapcd.org/rules/Appendix/AppenA/93115ATCM.pdf>
6. Even though there are some engine sizes that do not yet require Tier 3 Standards, the Base requires new engines to meet the most stringent standards available. In addition, the following requirements also apply:
The generator unit needs to comply with the CPEN Spill Prevention, Control, and Countermeasures (SPCC) Plan, which requires secondary containment for all fuel and fuel storage greater than 55 gallons. BMP also requires it for smaller quantities. There should not be an impact to federally listed wildlife species as a result of the project. Generally, all of the power units will be installed within the cantonment areas and adjacent to the buildings.

271300 and 271500 COX COMMUNICATIONS REQUIREMENTS

GENERAL

1. Project lead time notices to COX should be at least 6 months. Current pole applications take at least 4 months plus up to 2 months for construction. *The service can be brought in overhead or underground. The contractor shall assist the pathway and accessibility.*
2. If COX has a current active presence in the building, coordinate with COX prior to construction commencing.
3. Include COX for the Partnering Meetings *and Concept Design Workshops.*
4. Add COX contact by name in the plans and/or bid documents:

Construction Liaison, COX Communications, 1922 Avenida Del Oro, Oceanside, CA 92056
760/806-2050 Joe Griffith joe.griffith@cox.com
949/546-2466 Rey Castro rey.castro@cox.com Northern Camps
760/599-6060 Customer Service (ask for Planning)

DROP STANDARDS:

Home Run Drops (from tap to outlet)

1. Use RG-6 for pre or post wires.
2. Length not to exceed 250 feet (tap to set)
3. For drops greater than 250 feet and no more than 400 feet, use RG-11 for pre and post wires.
4. A minimum of two home run drops to any barracks room to be provided.
5. *DMX cable is not desired on the base.*

OVERVIEW:

1. Two 2" PVC conduits for roadway portions and minimum of one 2" PVC conduit to the inside MPOE.
2. Lengths no more than 500 feet between pedestals or communication rooms.
3. No more than three 90 degree sweeps between pedestals or communication rooms.
4. Backboard room sufficient for COX's equipment to feed drops being routed to that communication room. The more drops to the communication rooms, the more wall space that is required by COX.
5. *Minimum 2' x 2' backboard required depends on size conditions. Preferred 4' x 8' backboard.*
6. Provide a common box for connection interface with COX and Satellite Providers.
7. Locates for COX facilities can be handled through traditional resources: 811 and COX personnel.
8. For remodels COX requests involvement before construction begins, preferably during the base's assessment of the building. Provide requirements/specifications to include wiring/drop standards and coordination with COX.
9. *When Cox service is brought to a building, a wall mounted amplifier (size of a loaf of bread) is installed in the Comm. Room. The amplifier needs to be in an air cooled room (not air-conditioned) and have a dedicated 120v electric outlet to power a UPS supplying 89 vac to Cox's network to convert/boost signals.*
10. *The telecom closet shall have 19" width racks installed.*

271300 and 271500 STRUCTURED TELECOMMUNICATIONS CABLING and PATHWAY SYSTEM

PART 1 GENERAL

1.1 REFERENCES

The publications listed below form a part of this specification to the extent referenced. The publications are referred to within the text by the basic designation only.

- EIA/TIA-526-7 Optical Power Loss Measurements of Installed Single-Mode Fiber Cable Plant
EIA/TIA-526-14 OFSTP-14 Optical Power Loss Measurements of Installed Multimode Fiber Cable Plant
EIA/TIA-568 Commercial Building Telecommunications Wiring Standard
EIA/TIA-569 Commercial Building Standard for Telecommunications Pathways and Spaces
EIA/TIA-606 Administration Standard for the Telecommunications Infrastructure of Commercial Buildings
EIA/TIA-607 Commercial Building Ground and Bonding Requirements for Telecommunications
EIA/TIA-758 Customer Owned Outside Plant
NFPA 70 National Electrical Code
UL 497 Safety Protector for Paired Conductor Communication Circuit
UFC-3-580-1 Telecommunications Building Cabling System Planning, Design, and Estimating
UFC-3-580-10 Navy and Marine Corps (NMCI) Standard Construction Practices

1.2 DEFINITIONS

NMCI

End users/building tenants are responsible for contacting NMCI at least six months prior to project completion to order network service.

NMCI Contact: Karen Salazar STOIC Karen.Salazar@usmc.mil 760-763-4669

AREA DISTRIBUTION NODE (ADN)

A physical concentration or central location for terminating backbone cables to interconnect with local exchange carrier (LEC) equipment at the activity minimum point of presence. The ADN generally includes vendor specific components to support voice and data circuits, building surge protector assemblies, main cross connect blocks, equipment support frames, and fireproof wood backboard.

TELECOMMUNICATIONS ROOM (TR)

An enclosed architectural space for housing telecommunications equipment, cable terminations, and cross-connect cabling.

ENTRANCE FACILITY (EF)

An entrance to the building for both private and public network service cables (including antenna). This includes the entrance point at the building wall and continuing to the entrance room or space.

EQUIPMENT ROOMS (ER)

An architectural centralized space for telecommunications equipment and other building automations that provide services the occupants of the building. Equipment housed therein is considered distinct from a telecommunications use because of the nature of its complexity. Electromagnetic Compatibility shall be considered when designing this space.

1.3 SUBMITTALS

Submit the following in accordance with Section 013300, "Submittal Procedures."

SD-02 SHOP DRAWINGS

Telecommunications drawings to include T0, T1, T2, T3, T4 and T5

SD-03 PRODUCT DATA

Provide manufactures specifications on telecommunications cabling, telecommunications outlet/connector assemblies, equipment support frame, building protector assemblies, connector blocks, building entrance terminals, and other materials used.

SD-06 TEST REPORTS

Provide testing on telecommunications cable, utilizing a level III tester and a power source and light meter.

1.3.1 TELECOMMUNICATIONS DRAWINGS

Provide registered communications distribution designer (RCDD) approved drawings complete with wiring diagrams and details required to prove that the distribution system shall properly support connectivity from the telecommunications equipment room to telecommunications work area outlets. Show the entrance facility and layout of cabling and pathway runs, distribution frame, cross connect points, single point ground system, and terminating block arrangements. Drawings shall depict final telecommunications cabling configuration, including location, and terminating blocks layout at cross connect points and patch panels after telecommunications cable installation.

- a. T0 – Campus or site plan: exterior pathways and inter building backbone cable and pathways.*
- b. T1 - Layout of complete building per floor - Building Area/Serving Zone Boundaries, Backbone Systems, and Horizontal Pathways. The drawing indicates location of building areas, serving zones, vertical backbone diagrams, telecommunications rooms, access points, pathways, grounding system, and other systems that need to be viewed from the complete building perspective.*
- c. T2 - Serving Zones/Building Area Drawings - Drop Locations and Cable Identification (ID'S). Show's the building area, and the serving zone within the building. These drawings show drop locations, telecommunications rooms, access points and detail call outs for common equipment rooms and other congested areas.*
- d. T3 – Telecommunications equipment room (ER): plan views, telecommunications, and architectural, mechanical electrical and plumbing, elevations (racks and walls)*
- e. T4 - Typical Detail Drawings - Faceplate Labeling, Fire-stopping, Americans with Disabilities Act (ADA), Safety, Department of Transportation (DOT). The T4 will show detailed drawings of symbols and typical such as faceplate labeling, faceplate types, faceplate population installation procedures, detail racking, and raceways.*
- f. T5 - Schedule for cutovers*

1.4 DELIVERY AND STORAGE

Provide protection from weather, moisture, dirt, dust, and other contaminants for telecommunications cabling and pathway equipment placed in storage.

1.5 TELECOMMUNICATIONS QUALIFICATIONS

The telecommunications contractor shall be a firm which is regularly and professionally engaged in the business of the applications, installation, and testing of the specified telecommunications systems and equipment. The telecommunications contractor shall demonstrate experience in providing successful telecommunications systems within the past 3 years. Submit documentation for a minimum of three and a maximum of five successful telecommunication system installations for the telecommunications contractor.

1.5.1 INSTALLERS QUALIFICATIONS

Prior to installation, submit data of installer's experience and qualifications which shall include 3 years on projects of similar complexity. Include names and locations of two projects successfully completed using fiber optic and copper communications cabling systems. Include specific experience in installing and testing structured telecommunications distribution systems using fiber optic and copper communications cabling system

1.6 TEST PLAN

Provide a complete and detailed test plan for the telecommunications cabling system including a complete list of test equipment for the UTP and optical fiber components and accessories 30 days prior to the proposed test date. Include procedures for certification, validation, and testing. A level III tester shall be used on all projects.

1.7 RECORD DOCUMENTATION

NOTE: ANSI/TIA/EIA-606-A describes the necessary data fields and reports for hard copy, spreadsheet and electronic media as well as cable management software requirements. AC/S CIS Investigators are responsible for cable management software. Marine Corps Base Camp Pendleton is a class 4 activity; all labeling schemes will be provided by AC/S CIS Operations Department. Provide T5 drawings including documentation on cables and termination hardware in accordance with ANSI/TIA/EIA-606-A. T5 drawings shall include schedules to show information for cut-over and cable plant management, patch panel layouts and cover plate assignments, cross-connect information and connecting terminal layout as a minimum. T5 drawings shall be provided in hard copy format on electronic media using Windows based computer cable management software, all drawings will be provided in an AutoCAD and Adobe Acrobat format. Provide the following T5 drawing documentation as a minimum:

PART 2 PRODUCTS

2.1 COMPONENTS

2.1.1 PATHWAYS

Copper cabling shall be a minimum of 24-gauge solid core. Optical fiber shall be single-mode. These specifications apply in both premise and outside plant cable construction.

2.1.2 TELECOMMUNICATIONS CABLING

Copper cabling shall be a minimum of 24-gauge solid core. Optical fiber shall be single-mode. These specifications apply in both premise and outside plant cable construction.

2.1.3 BACKBONE CABLING

Solid conductors shall be multi-pair minimum Category 3, 24 AWG, formed into 25-pair binder groups covered with a thermoplastic jacket. All optical fiber in the backbone shall be minimum 12 strand single-mode optical fiber.

2.1.4 HORIZONTAL CABLING

Category 6, 24 AWG, four pair cable shall be used for all horizontal cabling.

2.1.5 EQUIPMENT SUPPORT FRAME

Shall be steel construction and treated to resist corrosion. 19-inch equipment racks shall be installed.

2.1.6 BUILDING ENTRANCE TERMINALS

Inter-building backbone cables shall be terminated on 110 type protected entrance terminals with

a splice closure. Outdoor type terminals which are mounted on the outside of buildings shall not be used, all terminals will be inside the building in the entrance facility (EF). Provide self-contained 5-pin unit supplied with a field cable stub factory connected to protector socket blocks to terminate and accept protector modules for a minimum of 25 pairs of outside cable. Building protector assembly shall have 710 interconnecting hardware for connection to interior cabling at full capacity.

2.1.6.1 PROTECTOR MODULES

Solid-state surge protectors provide protection for sensitive equipment which incorporates a fast semiconductor switch with operating voltage nearly independent of transient rise time. Otherwise, use gas tube protection modules in areas where lightning damage probability is very low, less than 5 strikes per year. Protector modules shall be in accordance with UL 497 gas tube or solid-state type 5 pin rated for the application. The gas modules shall shunt high voltage to ground, fail short, and be equipped with an external spark gap and heat coils in accordance with UL 497. Provide the number of surge protection modules equal to the number of pairs of exterior cable of the building protector assembly.

2.1.7 CONNECTOR BLOCKS

Type 110, Insulation displacement connections shall be provided for all copper cable.

2.1.8 FIBER OPTIC PATCH PANEL

Provide panel for maintenance and cross-connecting of fiber optic cables. Duplex SC panel connectors shall be provided to fill the spaces of the fiber patch panel.

2.1.9 TELECOMMUNICATIONS OUTLET BOXES

Utilize standard type 4 inches square by 2 1/8 inches deep device boxes with quad port face plates, unused ports shall be filled with blank inserts.

2.1.10 TELECOMMUNICATIONS OUTLET/CONNECTOR ASSEMBLIES

UTP jacks shall be keystone type, RJ-45, eight position rated for Category 6 service.

2.1.11 BACKBOARDS

Provide interior grade fire retardant plywood, 3/4 inch thick in 4 foot by 8 foot sheets.

2.1.12 GROUNDING AND BONDING PRODUCTS

Comply with EIA/TIA-607, and NFPA 70.

2.1.13 NAMEPLATES

Provide nameplate on door to read, "Telecommunications Room" in accordance with finishing schedule of the plans.

2.1.14 OUTSIDE CABLE PLANT

Outside plant copper wire shall have a minimum of 24-gauge, balanced twisted pair cabling that is filled core cable and meet the manufactures specification for the type of construction. Optical fiber shall be single-mode to meet the manufactures specification for the type of construction.

2.1.15 MAINTENANCE HOLES

Maintenance Holes shall be a minimum of 6'x12'x7'. Maintenance holes shall have

telecommunications on the cover. All maintenance holes shall have a ladder, cable shoes to rack the cable, 5/8" x 5 foot grounding rod and be traffic rated.

2.1.16 HAND HOLES

Hand holes shall be a minimum of 3'x 5'x 4'. Hand-holes are pull-through points and there shall be no splicing in hand-holes. Hand-holes shall have telecommunications on the cover, and the doors shall be hinged. All hand-holes shall have cable shoes to rack the cable, and be traffic rated.

2.1.17 INNERDUCT

Provide a three inch, three-chamber MaxCell inner duct or equivalent three inch, multi-celled, textile inner duct system for the placement of optical fiber cables within 4' conduit in the following quantities:

In 2-4" duct banks place 1 three inch, three-chamber MaxCell inner duct in one of the conduits
In 4-4" duct banks place 3 three inch, three-chamber MaxCell inner duct in one of the conduit
In 6-4" duct banks place 3 three inch, three-chamber MaxCell inner duct in two of the conduit
In 8-4" duct banks place 3 three inch, three-chamber MaxCell inner duct in three of the conduit.

Corrugated inner duct shall not be used.

2.1.18 SPLICE CLOSURES housing, encapsulating compound shall not be used. Closure shall be of suitable thermoplastic, or stainless steel material supplying structural strength necessary to pass the mechanical and electrical requirements in an OSP environment. Size of closure shall be determined by MCIWEST G-6. Optical Fiber Splice Closures shall be suitable to house splice organizer in a protective housing. Closure shall be of thermoplastic, or stainless steel material supplying structural strength necessary to pass the mechanical and electrical requirements in an OSP environment. Size of closure shall be determined by MCIWEST G-6.

Metallic Splice Closures shall be suitable to house a straight and butt splices, and in a protective

2.1.19 MANUFACTURER'S NAMEPLATE

Each item of equipment shall have a nameplate bearing the manufacturer's name, address, model number, and serial number securely affixed in a conspicuous place; the nameplate of the distributing agent will not be acceptable.

PART 3 EXECUTIONS

3.1 INSTALLATION

Telecommunications cabling and pathway systems, including the horizontal and backbone cable, pathway systems, telecommunications outlet/connector assemblies, and associated hardware shall be installed in accordance with EIA/TIA-568, EIA/TIA-569, NFPA 70, and UL standards as applicable. Cabling shall be connected in a star topology network. Reference UFC 3-580-01 and UFC 3-580-10.

3.1.1 HORIZONTAL CABLE

Install Category 6 telecommunications cabling utilizing the T568A standard. Use an approved insulation displacement connection (IDC) tool kit for copper cable terminations. Do not untwist Category 6 UTP cables more than one-half inch from the point of termination to maintain cable geometry. Provide a 10-foot service loop in the telecommunications room, a 3-foot above the work-area outlet in the overhead ceiling and 1-foot of excess cable in the work-area outlet box.

Do not exceed manufacturers' cable pull tensions for copper and fiber optic cables. Do not chafe or damage outer jacket materials. Use only lubricants approved by cable manufacturer. Velcro shall be the only acceptable material used to maintain cable management. When open-top wire supports ("J" hooks) are used for wire distribution in an open or dropped ceiling installation, they shall be spaced 4'-5' apart. There shall be no more than (6) CAT 6 cable drops per location when serving multiple telecommunications outlets with one conduit stubbed into the ceiling cavity. Install no more than two 90 degree bends for a single horizontal cable run. Conduits shall be a minimum of 1".

3.1.2 BACKBONE CABLE

Install backbone copper and optical fiber cable between Telecommunications Rooms. Terminate copper cable on an approved 110-type IDC connections, optical fiber shall be terminated utilizing SC connectors. The designer shall coordinate with MCIWEST G-6 for the termination locations in the Telecommunications Room.

3.1.3 OUTSIDE CABLE PLANT

Comply with EIA/TIA-758. Keep conduit minimum 6 inches away from parallel runs of electrical power equipment, flues, steam, and hot water pipes. Install conduit parallel with or at right angles to ceilings, walls, and structural members where located above accessible ceilings and where conduit is visible after completion of project. Run conduits in crawl spaces and under floor slabs as if exposed. The minimum requirement for copper is 25-pairs and for single mode optical fiber is 12-strands. Coordination with AC/S CIS will be required to get a point of connection for both cable and telecommunications pathways.

3.1.4 SERVICE ENTRANCE CONDUITS, UNDERGROUND

A minimum of two, four-inch conduits shall be provided from the point of connection to the building entrance for telecommunications. One duct will be used for optical fiber and have a 3-port cloth inter-duct like Maxcell or an equivalent product, any unused ducts shall have a ¼ inch pull rope placed in them and be tied off at both ends. Unused conduits shall be have duct plugs installed.

3.1.5 CABLE TRAY

Cable tray shall be installed in the Telecommunications Rooms so that cables can easily be routed from equipment racks and backboards to conduits, stubs and sleeves that exit the space and sufficiently supported.

3.1.6 CONDUITS

All conduits that are installed shall have a pull rope placed in them for future use; all conduits will be plugged utilizing conduit duct plugs. The minimum size of a conduit is 1-inch in horizontal pathways, 4-inches in sleeve's leaving the Telecommunications Room, 4-inch continuous conduit between telecommunications spaces and 4-icnhes for building entrance.

3.1.7 WORK AREA OUTLETS

Terminate Category 6 cable in accordance with EIA/TIA-568 wiring configuration T586A. All work area horizontal cabling shall be terminated in quad-port face plate and mounted at the same elevation as the electrical outlets. Un-used ports will have blank inserts placed in the faceplate.

3.1.8 EQUIPMENT RACK

The following clearances are required: 3' minimum clearance on all sides of the equipment rack. The telecom rack shall be located to give maximum access to all of the equipment contained in and on the rack without obstruction. The equipment rack shall contain space for a fiber optic patch panel of sufficient size to terminate all fiber optic cables entering the closet. This fiber optic

patch panel shall be mounted at the top of the rack. The telecom rack shall have T568A 110-type termination fields and placed below the fiber optic patch panel for termination of the data (blue) cable from each workstation outlet. All Cat 6 terminations shall conform to the T568A USOC wiring standard. There shall be sufficient room on the rack to mount the data equipment needed for the closet (switch, repeater hub, etc.). This equipment shall be placed below the bottom wire management panel. The telecom rack shall have horizontal/vertical cable management to keep all patch cables and wiring organized and neat in appearance. There shall be braced cable runways on the top of the rack and wall support kits. Equipment rack and wall mounted enclosures shall be designed with Seismic considerations in accordance with NEBS Qr-63 for Zone 4.

3.1.9 CABLE SPLICING

All splicing materials shall be provided by the telecommunications contractor.

3.1.9.1 OPTICAL FIBER

Provide Optical Fiber splicing materials for fusion methods at locations shown on the construction drawings. Optical Fiber splicing shall be in accordance with manufacturer's recommendation and shall exhibit an insertion loss not greater than 0.2 dB for fusion splices and not greater than 0.4 db for mechanical splices.

3.1.9.2 METALLIC CABLE

Multi-pair splices are insulation displacement (IDC) type splices. Provide multi-pair, fold-back, in-line, single pair, splices of a moisture resistant, two or three wire insulation displacement connector held rigidly in place to assure maximum continuity. Cables greater than 25 pairs shall be spliced using multi-pair splicing connectors, which accommodate 25 pairs of conductors at a time. Provide correct connector size to accommodate the cable gauge of the supplied cable. 710 splicing is the preferred method for MCB Camp Pendleton.

3.1.10 CONNECTION BLOCKS

Connector blocks shall be 110-type IDC and wall mounted in orderly rows and columns. Adequate vertical and horizontal wire management routing areas shall be provided between groups of blocks. Install in accordance with industry standard wire routing guides in accordance with ANSI/TIA/EIA-569-A.

3.1.11 PATCH PANELS

Patch panels shall be mounted in equipment racks with sufficient ports to accommodate the installed cable plant plus 25 percent spares. Copper cable entering a patch panel shall be secured to the panel with cable ties as recommended by the manufacturer to prevent movement of the cable. Fiber optic cable loop shall be 3 feet in length provided as recommended by the manufacturer. The outer jacket of each cable entering a patch panel shall be secured to the panel to prevent movement of the fibers within the panel, using clamps or brackets specifically manufactured for that purpose.

3.1.12 PENETRATIONS

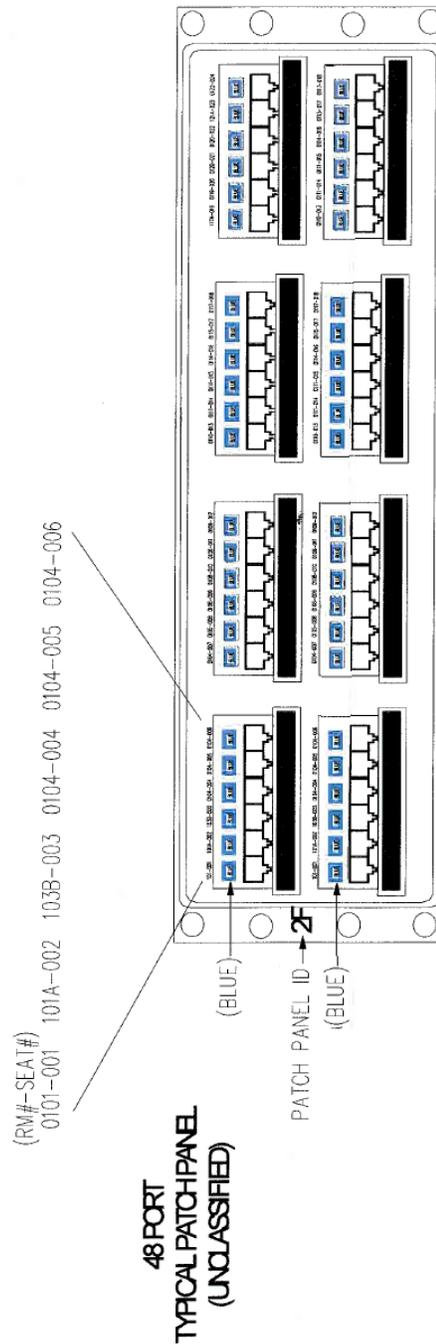
Caulk and seal cable access penetrations in walls, ceilings and other parts of the building. Seal openings around electrical penetrations through fire resistance-rated wall, partitions, floors, or ceilings.

3.1.13 LABELING

The system shall be labeled utilizing the NMCI wiring standard. At the workstation, voice ports will be labeled "V" to the top left of the top port (gray insert) and data ports shall be labeled "D1" to the left of the bottom port (blue insert) and "D2" to the right (blue insert). In the case of faceplates with ports side by side, the "V" and "D" shall be on top of the ports and the number of the port shall be placed at the bottom of the faceplate. Labels shall be placed on the sides of the 110 block/panel to mark each 4 pair CAT 6 cable. All labeling shall be provided by a label making

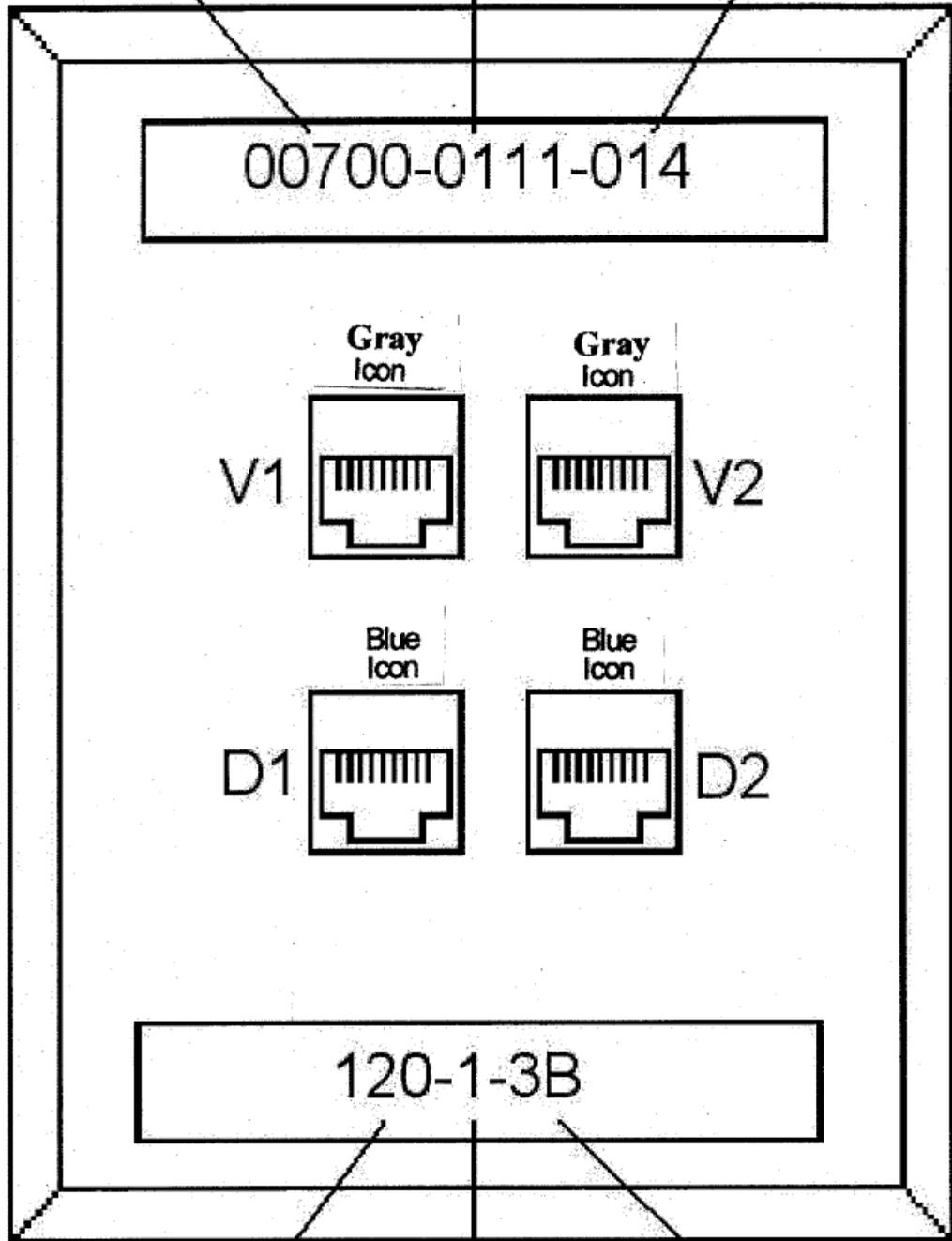
machine utilizing thermal transfer and shall be black text on white backing, self-adhesive laminated label tapes. The font size of the labels shall be appropriate for the part it pertains too.

3.1.13.1 EXAMPLE OF THE WORK-AREA LABELING SCHEME.



3.1.13.2 EXAMPLE OF THE PATCH-PANEL LABELING SCHEME

Building Number-Room Number-Drop(Seat) Number



Closet Number-Rack Number-Patch Panel

3.1.13.3 CABLE TAG INSTALLATION

Verify labeling standard requirements with MCIWEST G-6. Label in accordance with ANSI/TIA/EIA-606-A. Install cable tags for each telecommunications cable or wire located in maintenance-holes, hand-holes, and vaults including each splice. Tag only new wire and cable provided by this contract. Tag new wire and cable provided under this contract and existing wire and cable that are indicated to have splices and terminations provided by this contract. The labeling of telecommunications cable tag identifiers shall be as indicated in accordance with ANSI/TIA/EIA-606-A. Tag legend shall be as indicated. Do not provide handwritten letters. Install cable tags so that they are clearly visible without disturbing any cabling or wiring in the manholes, hand-holes, and vaults.

3.2 TESTING

3.2.1 TELECOMMUNICATIONS CABLE TESTING

Perform telecommunications cabling inspection, verification, and performance tests in accordance with EIA/TIA-568. Level III testers shall be used on all Category 6 cable, and a power source and light meter shall be used on optical fiber. Test results shall be provided in a pdf format, so that they are non-editable. 2 copies on paper and 4 electronic copies of the test reports shall be provided.

3.3 CONTRACTOR DAMAGE

Promptly repair indicated utility lines or systems damaged during site preparation and construction. Damages to lines or systems not indicated, by as-builts provided or not identified by third party locating services, which are caused by contractor operations, shall be treated as Changes under the terms of the Contract Clauses. When Contractor is advised in writing of the location of a non-indicated line or system, such notice shall provide that portion of the line or system with "indicated" status in determining liability for damages. In every event, immediately notify the MCIWEST G-6 Operations Department of damage. Compounds and tape are not acceptable substitutes for heat shrinkable end caps. Cable, which is not sealed in the specified manner at all times, will be rejected.

3.4 GROUNDING

Designer should verify the existence of grounding facilities. It is essential that all grounding facilities, new and existing, conform to ANSI-J-STD-607.

3.4.1 TELECOMMUNICATIONS MAIN GROUNDING BAR (TMGB)

The TMGB is the hub of the basic telecommunications grounding and bonding system providing a common point of connection for ground from outside cable to the building and equipment. Establish a TMGB where the OSP cables enter the building. All pathways, equipment racks, and metallic components shall be connected to the TMGB.

3.5 TELECOMMUNICATIONS ROOM (TR)

The telecommunications room shall be designed in accordance with UFC 3-580-10 Chapter 2-4.1 thru 2-4.9. The default starting size for the telecommunications room is 10' x 8'.

271400 TELECOMMUNICATIONS BUILDING REQUIREMENTS

(Cabling Systems, Planning, Design, and Estimating Classified Information Infrastructure)
Assistant Chief of Staff, Communications and Information System Department is recommending that building requirements for future Protected Distribution Systems Design as follow:

1. National Security Telecommunications and Information Systems Security Instruction (NSTISSI) No. 7003, Protective Distribution Systems (PDS), provides guidance for the protection of wire line and optical fiber PDS to transmit unencrypted classified National Security Information (NSI). This instruction is effective upon receipt, and supersedes NACSI No. 4009, Protected Distribution Systems, dated 30 December 1998 and Appendix K, NACSEM 5203, Guidelines for facility Design and RED/BLACK Installation, dated 30 June 1982. Please check with your agency for applicable implementing documents.
2. The major differences between this revision and the previous version are the identification of installation and physical security practices clarification of certain exempted applications from the approval process, the inclusion of government contractors in the scope of this publication, and the inclusion of detailed installation requirements.

2-1 Classified Information Infrastructure Space Design requirements

This instruction stipulates approval authority, standards, and guidance for the design, installation, and maintenance of Protected Distribution Systems (PDS). This instruction incorporates a philosophy of "risk management" in lieu of the "risk avoidance" philosophy employed in the previous document. Absent specific facts, unique to each facility, suggesting greater or lesser risks, these standards shall be applied. However, sensible risk management practice dictates each facility must be evaluated on its own risks and vulnerabilities based on factors such as location, physical security, environment, access controls, personnel security requirements, etc. The overall security afforded by PDS is the result of a layered approach incorporating various protection techniques. The emphasis is placed on "detection" of attempted penetration in lieu of "prevention" of penetration. Criteria called out are based on threat or risk analysis relative to the location of the PDS. This generally results in reduced requirements and cost savings during installation and maintenance of PDS. The decision as to what extent the guidance provided in ANNEX B is followed ultimately rests with the department or agency Approval Authority.

SECTION III -SCOPE

This instruction applies to U.S. Government departments and agencies and their contractors and vendors who use, or are contemplating the use of a PDS to protect the transmission of unencrypted classified National Security information (NSI). This instruction Protective Distribution Systems 13 Dec 1996 3

2-1-2 Controlled Access Area (CAA)

- (a) A physical area (e.g. building, room, etc) which is under physical control and to which only personnel, cleared to the level of information being processed, are authorized unrestricted access. All other individuals are either escorted by authorized personal or are under continuous surveillance. A CAA shall comply with the CAA physical requirements of Section 4 with in a CAA, a PDS will not be required for classified information processed at or below the classification level to which access to the CAA is controlled. While unprotected cables may run with in a CAA, they will not run outside the perimeter of the CAA. Safeguarding and storage of magnetic and hardcopy media will be in accordance with REF (b).
- (b) Doors: The access door to the area shall be substantially constructed of wood, metal or solid material. If Double doors are installed, an astragal will be installed on active leaf of the door.
- (c) Locks: The locks shall meet FF-L-2890 Specifications requirements, for Camp Pendleton. CAA doors will use XO-9 Locks.
- (d) Walls, floor and roof: The walls, floor, and roof construction shall be of permanent construction materials (i.e. plaster, gypsum, wallboard, metal panels, hardwood, plywood, or other materials. Offering resistance to and evidence of unauthorized entry into area. Wall shall be

extended from true floor to true ceiling with permanent materials or 18-gauge expanded steel screen. If the walls cannot be extended, then an intrusion detection system shall be installed to monitor the space above the terminal.

- (e) Windows: All windows which might reasonably afford visual observation of classified activities within the facility shall be made opaque or equipped with blinds, drapes or other coverings. Windows less than 18 feet above the ground measured from bottom of window, or are easily accessible by means of objects directly beneath the windows, will be locked at all times. The locking mechanism and window construction shall be such as to provide indications, of any attempt of forced entry. If the construction is inadequate to provide said indication, then protective coverings, such as bars, need to places over the windows. The protection provided to the windows need be no stronger than the strength of the contiguous walls. Windows containing climate control units (e.g. air conditioners) must be secured in a manner to provide indications of any attempt at forces entry.
- (f) Openings: Utility openings such as ducts and vent shall be kept at less than man-passable (96 square inches). Openings larger than 96 square inches shall be hardened per Military Handbook 1013/1B

2-1-3 Restricted Access Area (RAA)

- (a) A physical area (e.g., building, room, etc) that is under physical control and to which only personnel cleared to level of the information being processed are authorized unrestricted access. Authorized personnel escort all other personnel. A RAA shall comply with RAA physical requirements section 4. Safeguarding and storage of magnetic and hard copy media will be in accordance with IA 5239-22.
- (b) Doors: The access door to the area shall be a security deadbolt lock with a one inch throw, with cylinder which meets the requirements of Underwriters Laboratories inc. UL-437 standard key lock, 7th edition dated 4 Aug 2000. The hinge pins of out swing doors shall be pinned brazed, or spot weld to prevent removal. Doors other than access doors shall be secured from the inside (for example, by a dead bolt lock, panic dead bolt lock, or rigid wood or metal bar which extends across the width of the door, or by any other means that will prevent entry from the outside)
- (c) Locks: The locks shall meet FF-L-2890 Specifications, UL-437 Key Cylinder High Security dead bolt with a 1 inch throw, are requirements, for Camp Pendleton, we use the UL-437 Schlage Primus or Everest due to lock smith having the ability and training to R-KEY locks. This should include blank keys for every facility.
- (d) Walls, floor and roof: The walls and floor construction shall be of permanent construction materials (i.e. plaster gypsum wallboard, hardwood, wood, plywood, or other materials) offering resistance to and evidence of unauthorized entry into area.
- (e) Windows: All windows which might reasonably afford visual observation of classified activities within the facility shall be made opaque or equipped with blinds, drapes, or other coverings. Windows that are less than 18 feet above the ground measured from bottom of the window, or are easily accessible by means of object directly beneath the windows will be locked at all times. The locking mechanism shall be such to provide indications of any attempt to forces entry, key lock. Windows containing climate control units (i.e. air conditioners) must be secured in a manner to provide indications of any attempt at forces entry.
- (f) Opening: No stipulations.

2-1-4 Protected Distribution Systems (PDS) Installation and Design

(a) The system of carriers (conduits, ducts, etc) that are used to distribute National Security Information.

1. A PDS must originate in a SR or CAA
2. A PDS must terminate in a SR, CAA, or RAA
3. A lock box must be used to terminate in a RAA
4. A Workstations must be protected in a RAA
5. A PDS may traverse but not terminate in a LAA
6. A PDS may not traverse or terminate in a UAA

(b) The Certification Authority validates all areas described in the PDS approval request except SR, CAA or RAA does not protect magnetic media, follow SECNAVINST 5510.36

1. Category II PDS
 - a. Replaces the "Hardened" PDS, Hardened is now a type of carrier for a Category II PDS
 - b. Most common Category of PDS
2. There are 5 types of Category II carriers
 - Hardened
 - Buried
 - Suspended
 - Alarmed
 - Continuously Viewed

(c) Protected Distribution System Design

1. Most common type of carrier inside buildings
2. The carrier must be constructed from metallic conduit, such a EMT
3. Armored cable and flexible spiral wound conduit cannot be used
4. Joints must be sealed with epoxy

(d) Buried PDS

1. Man holes and hand holes must be sealed (welded), locked with PDS lock and inspectable, or alarmed
2. The carrier should enter the building from underground
3. Carriers traversing crawlspaces require rigid steel pipe and/or other additional measures
4. If the carrier enters the side of the building, metal conduit or plastic conduit encased in concrete must be used

(e) Suspended Carrier

1. Uncommon
2. Used between buildings in close proximity when a buried carrier is not possible or cost effective
3. The carrier must be 5 meters high with no poles
4. The ends of carrier must terminate in Secure Room or CAA
5. Area traversed must be owned/leased by U.S.

(f) Alarmed Carrier

Requires alarm test but no visual inspection

1. Subject to false alarms
2. Used when an IDS is already installed in the facility

3. Used for a PDS installed out of view, such as above false ceilings and below false floors
4. Two types of Alarmed Carriers approved:
 - a. Volumetric IDS, Area surrounding entire length of PDS must be covered.
 - b. Fiber Optic Intrusion Detection System (FOIDS) by Fiber SenSys or Interceptor

(g) Continuously Viewed Carrier

1. Uncommon
2. Used when the area is already monitored by a guard or a camera monitoring system is in place
3. The carrier must be in metal or plastic conduit
4. Must be viewed 24/7

(h) Installation

1. The PDS carrier must be installed in view
 - Except Alarmed carriers
 - Generally installed just below false ceiling
 - May not be installed above false ceiling, behind furniture or in walls
2. The carrier should be marked at distances less than 3 meters, should not use the red markings
3. The PDS is routed across hallway below the ceiling
4. Also routed along hallway wall below ceiling



(i) Pull boxes and drops boxes.

1. Boxes must be continuous metal
2. No knockouts or pre-punched knockouts
3. Covers must be welded or sealed with epoxy
4. No removable hinges
 - Hinges with exposed ends are not allowed, even with epoxy
5. Lock boxes may be used for re-entry into pull boxes or for terminations in an RAA
6. Lock boxes must meet requirements of pull box
7. Must have permanently secured locking hardware
 - No screws
 - A locking tab protruding through a slot in the door is the best type
8. In a RAA, the network cable must be secured in the lock box

(j) Pull boxes and drop boxes.

1. Good Example
 - Hidden Hinge
 - No knockouts
 - Tap protruding though slot

- McKinstry Enclosures *or approved equal.*



No longer available

- Good Example
 - Hidden Hinge
 - No knockouts
 - External Tab
- Performance Metal Fabricators 9930-805-CB-series, *or approved equal.*



“Joints must be sealed around all mating surfaces”

- Non-locking pull boxes and condulets must be bonded around all mating surfaces



(k) Physical Security RAA Locks

- ASSA
 - V6000 series locks, *or approved equal.*
- CA POC:



- Medeco Maxum series, *or approved equal.*



(I) Pull boxes and lock box locks

1. The only lock currently available that meets the PDS lock specification is the S&G 8077.
2. National Stock Number for bulk purchase (24) of 8077-102 is
 - 5340 00 285 6523Unified Facilities Criteria (UFC) Protected Distribution Systems for Classified Information Infrastructure 21400

PDS CONDUIT INSTALLATION

PDS Design, Installation, and Certification Guidance

1. The references listed in UFC-3-580-10 will be adhered to when Protected Distribution Systems are included on designs for new facilities that will require secure space modifications for processing up to secret information. Any questions or concerns pertaining to design, hardware, or technology should be brought up the attention of Certified Tempest Technical Authority (CTTA) for Marine Corps Base, Camp Pendleton, Communications and Information Systems G-6. All commands will adhere to and acknowledge these procedures and processes.
2. SECTION III -SCOPE
This instruction applies to U.S. Government departments and agencies and their contractors and vendors who use, or are contemplating the use of a PDS to protect the transmission of unencrypted classified National Security information (NSI). This instruction Protective Distribution Systems 13 Dec 1996 3
 - a. Physical Security
 1. A PDS must originate in a SR or CAA
 2. A PDS must terminate in a SR, CAA, or RAA
 - A lock box must be used to terminate in a RAA
 - Workstations must be protected in a RAA
 3. A PDS may traverse but not terminate in a LAA
 4. A PDS may not traverse or terminate in a UAA
 5. The Certification Authority validates all areas described in the PDS approval request except a SR
 6. CAA or RAA does not protect magnetic media, follow SECNAVINST 5510.36

Please direct questions to the Communications Information Systems at **(760) 763-1975**

275116 & 211313 FIRE PROTECTION and SECURITY REQUIREMENTS

1.0 FIRE ALARM

- 1.1 All alarm initiating devices shall be addressable. All components shall be individually attached to or contain an addressable device. All devices shall be easily accessible.
- 1.2 In Section D4010, Fire Alarm and Detection System. All Devices requiring a key to access equipment and reset devices will be keyed alike with a CAT 60 key.

- 1.3 Type THWN/THHN insulated wire is not acceptable for underground wiring of fire alarm circuits. Provide type THW or XHHW for wiring in wet locations.
- 1.4 Surface boxes, when provided for surface mounted manual pull stations, shall be the station manufacturer's approved back box. Back box finish shall match station finish. Surface boxes shall have smooth side surfaces devoid of any knockouts. The surface boxes shall closely match the exterior contour of the manual pull stations.
- 1.5 A building floor plan shall be located and permanently mounted next to the FACP. The floor plan shall be at a minimum laminated, show all initiating devices, all room numbers/names, and device addresses.
- 1.6 If a Mass Notification System (MNS) is required, the system shall be combined with the fire alarm.
 - 1.6.1 LED text signs are not required as part of the MNS system.
 - 1.6.2 Provide clear strobes marked with the word "ALERT" for shared use by the building's combination MNS/FA.
 - 1.6.3 A means to initiate prerecorded MNS messages at the buildings MNS/FA panel will not be required. "However, the FA/MNS panel must have the capability to provide at least eight pre-recorded messages."
- 1.7 The FACP must have the capability to silence fire alarm audible signals including water-flow signals.
- 1.8 The Digital Alarm Communication Receiver (DACR) located at the Joint Emergency Communications Center is a Radionics/Bosch D6600. The receiving station dispatch software is GE MasterMind Monitoring Software. The preferred mode of fire alarm signal transmission is Contact ID. The primary and backup phone numbers will be made available during the pre-final inspection. The fire alarm control panel shall be programmed with primary and backup phone numbers.
 - 1.8.1 The DACR shall receive a distinct description for each type of initiating device.
- 1.9 The phone lines must be installed in conduit from the DACT location to the telephone backboard location.
- 1.10. All site specific programming, software, and pass codes must be provided to the base prior to final acceptance of the fire alarm system.
- 1.11. The FA/MNS system batteries must provide 60 hours of standby power followed by 15 minutes of alarm power.

2.0 Fire Sprinkler

- 2.1 Provide locks and chains on back flow preventer in lieu of tamper switches.
- 2.2 Locate FDC facing the street so it is easily accessible to the Fire Department.
- 2.3 Shotgun risers must be provided eliminating the alarm check valve and retard chamber style.
- 2.4 All exposed steel piping that is used for water fire demand shall be painted in the industry standard color "red" to signify fire systems and include a backflow device.

3.0 KNOX Box

1. Provide all KNOX Boxes *model #3275 recessed mounted with hinged door.*
2. Exact size and location for installation and ordering shall be coordinated with Camp Pendleton Fire Department.
3. *Provide master keys and fire alarm keys in knox box.*
4. *Provide knox box even if there is a 24 duty desk inside the facility.*
5. *Base Fire Dep. has an order form for the knox boxes.*
6. *Mount knox boxes on outside of building near front entrance not higher than 6'*

4.0 FIRE ACCESS LANE

The minimum inside turning radius for any fire access lane shall be **37 feet**. All fire lanes shall be 20' wide all weather paving with continuous 13'-6' vertical clearance.

PHYSICAL SECURITY REQUIREMENTS for MASS NOTIFICATION SYSTEM

MCO 5530.14A, Chapter 1, Page 1-10, Section 1010.

PROJECT PLANNING. All plans for construction, MILCON, and facility sustainment, repair, and modernization (FSRM) must incorporate physical security, AT, and FP features, in accordance with references.

DODI 5200.08, "Security of DOD Installations and Resources," December 10, 2005

DODI 2000.16, "DOD Antiterrorism (AT) Standards," October 2, 2006

UFC 4-010-01, "DOD Minimum Antiterrorism Standards for Buildings," February 9, 2012

UFC 4-021-01, "Design and O&M: Mass Notification Systems," January 1, 2010

MCO P11000.5G

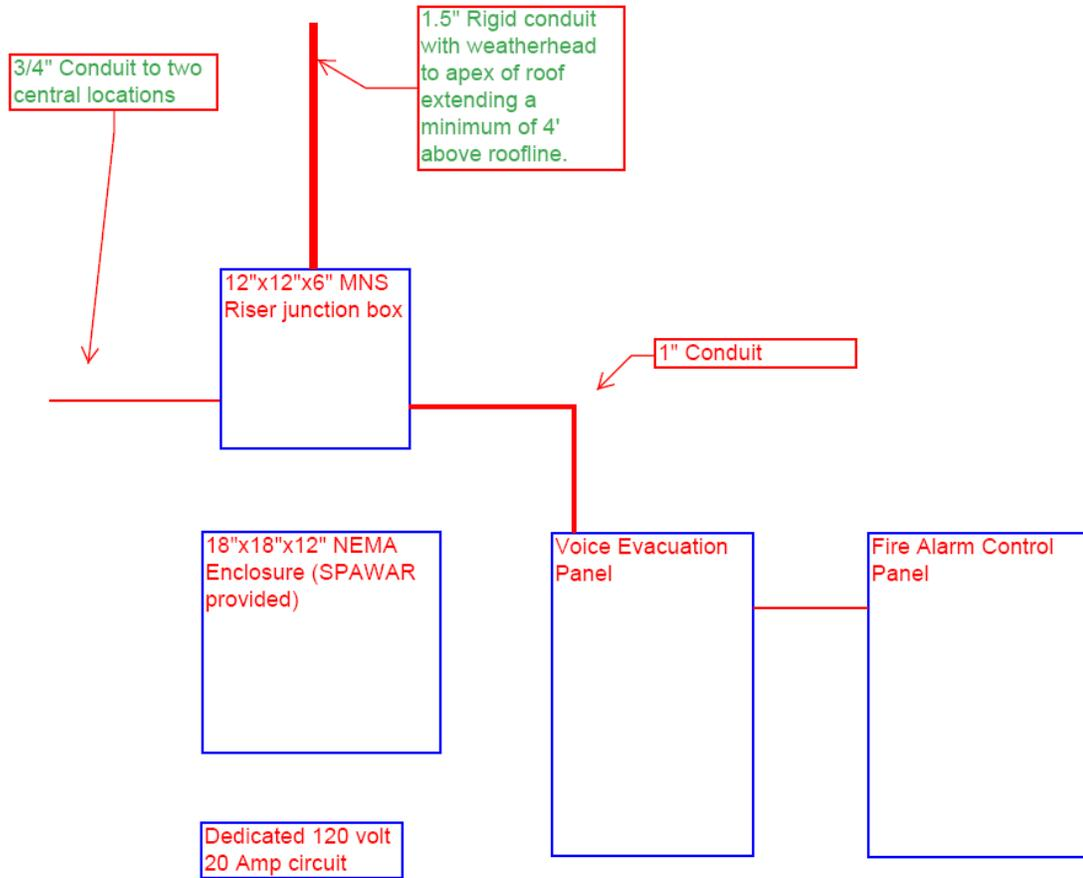
MCO P11000.12C

MCO 5530.14.A "MARINE CORPS PHYSICAL SECURITY PROGRAM MANUAL"

SECNAV M-5510.36 "Department of the Navy Information Security Program"

1. USMC Mass Notification System (MNS) utilizes the WAVES – Wireless Audio Visual Alerting Emergency System. Equipment should be Cooper Notification, SGIS or approved equal.
2. The Voice Panel (Cooper Notification ACU-340 or approved equal) connects to the Fire Alarm Control Panel (FACP). The combination Fire/VOICE Evacuation Panel is to be capable of passing live and pre-recorded audio. The system is to have an Auxiliary Line Level Audio Input and integration package available to connect to the Radio Transceiver. The Fire/VOICE Evacuation System must be installed stand-alone as part of the project.
3. The MNS Radio Transceiver (Cooper Notification TRX-401 or approved equal) links the building back to the Central Control Station at PMO and also connects to the ACU (see diagram). This wireless link back to the PMO has an RF cable to an external antenna. This system delivers all audio messages from the Base Station(s) to the respective alerting areas and facilities. It has a battery back-up (UPS-901 or approved equal) and is installed within 15 cable feet of the Voice Panel. The MNS Radio Transceiver and the Fiberglass NEMA Enclosure (SPAWAR provides) measures approx. 18" x 18" x 12" and requires a 110/220 VAC terminated to a 20 amp breaker.
4. Provide a 1.5" diameter rigid conduit run from a 12" x 12" x 6" junction box near the install location of the MNS Radio Transceiver out to the apex of the roof with a weather head termination a minimum of 4 feet above the roofline for the external antenna.
5. Two local speakers are to be connected directly to the MNS Radio Transceiver. A ¾" conduit is to run from the MNS Radio Transceiver location (12" x 12" x 6" junction box) to two central locations of the facility (duty room, administration room, command area, central hallway, day lounge, etc.) The conduit should be routed to the speaker mounting areas with a flush mounted 4x4x4 EMT box with (decorative) cover or to a location above a suspended acoustical ceiling (well marked for MNS). All dedicated conduit runs for the MNS Antenna and speakers are to have a pull string and shall be adequately marked.
6. Provide a 1" conduit from 12" x 12" x 6" junction box to the Fire/VOICE Evacuation Panel.

7. *It is preferred that the company installing the Fire System and voice capable speakers and strobes (strobes to be marked with "ALERT") be activated by the FACP as well as the MNS. Combination speaker/strobes are preferred for a cleaner installation.*
8. *All plans for MILCON and FSRM construction must be reviewed by the Provost Marshal or designated representative, and the installation Security Officer during the design process, all subsequent design review phases, and the final (100%) drawings.*
9. *All construction projects, to include MILCON and FSRM projects will be reviewed by the installation physical security chief and Antiterrorism Officer (ATO) and verified by Security Division (PS) and CMC (I&L) during validation, to ensure physical security and force protection requirements have been addressed.*
10. *Contract for bid will not be processed without documentation of design review by security and AT representatives.*
11. *In those instances where construction projects require Electronic Security Systems (ESS), (including Intrusion Detection, Mass Notification Systems (MNS), Closed Circuit Television (CCTV), etc.) commands must ensure that the installation physical security chief forwards a request for support and/or cost estimates to Security Division (PS). This will provide notification of a requirement and allow sufficient time for planning and funding. Security Division (PS) manages a centrally funded program that provides security services and equipment to the installations. These systems and equipment are considered collateral equipment and cannot be funded with MILCON funds but can be included in the MILCON project contract for contracting efficiency provided the funding is separate and distinct from MILCON funds.*
12. *Commands must ensure that infrastructure requirements are coordinated with and reviewed by installation communications and information management and Public Works offices.*
13. *Submit an electronic furniture floor plan (required for mass notification and intrusion detection systems).*
 - a. *HQMC funded projects 1 to 3 years out.*
 - b. *Site funded projects as soon as user identifies areas requiring IDS.*
 - c. *No later than 50% design review. (Meeting with Physical Security and end user is required)*



Vault and Secure Room (Open Storage Area) Construction Standards

MCO 5530.14A, Chapter 7, Section 7006, Page 7-23

1. Vault
 - a. Floor and Walls. Eight inches of reinforced concrete to meet current structural standards. Walls will extend to the underside of the roof slab.
 - b. Roof. Monolithic reinforced concrete slab, with the thickness determined by structural requirements, but no less than the floors and walls.
 - c. Ceiling. The roof or ceiling will be reinforced concrete of a thickness to be determined by structural requirements, but not less than the floors end walls.
 - d. Doors. Vault door and frame units will conform to Federal Specification AA-D-2757, Class 8 vault door, or Federal Specification AA-D-600, Class 5, vault door. Doors will be equipped with a built-in GSA-approved combination lock meeting Fed Spec FF-L-2740.
2. Secure Room
 - a. Walls, Floor, and Roof. Walls, floor, and roof construction will be of permanent construction materials; plaster, gypsum wallboard, metal panels, hardboard, wood, plywood, or other materials offering resistance to, and evidence of unauthorized entry into the area. Walls will extend to the true ceiling with permanent construction materials and 18-gauge expanded steel screen on one face.

- b. Ceiling. Ceilings will be constructed of plaster, gypsum, wallboard material, hardwood, or any other acceptable material.
- c. Doors. The access doors to the room will be substantially constructed of wood, metal, or other solid material and equipped with a built-in GSA-approved combination lock meeting Federal Specification FF-L-2740. For open storage areas approved under previous standards, the lock may be a previously approved GSA combination lock until the door has been retrofitted with a lock meeting Fed Spec FF-L-2740. When double doors are used an astragal will be installed on the active leaf of the door. The hinge pins of the out-swinging doors will be peened, brazed, spot-welded, or equipped with a hinge secure pin to prevent removal. Doors other than access doors shall be secured from the interior (e.g., by a dead bolt lock, panic dead bolt lock, rigid wood or metal bar that extends across the width of the door, or by any other means that will prevent entry from the exterior). Key operated locks that can be accessed from the exterior side of the door are not authorized. A balanced magnetic switch meeting Underwriters Laboratory (UL) 634 standards will protect each perimeter door.
- d. Windows. All windows that might reasonably afford visual observation of classified activities within the facility will be made opaque or equipped with blinds, drapes, or other coverings. Windows located less than 18 feet above the ground (measured from the bottom of the window), or that are easily accessible by means of objects directly beneath the windows will be constructed from, or covered with, materials which provide protection from forced entry. The windows will be protected with an IDS, either independently or with motion detection sensors in the space. Window protection does not need be stronger than the contiguous walls.
- e. Openings. Utility openings such as ducts and vents will be kept at less than man-passable (96 square inches) opening. Openings larger than 96 square inches will be hardened per reference (q).

(q) MIL-HDBK-1013/1A, "Military Handbook Design Guidelines for Physical Security of Facilities," October 9, 1987 Armories

Point of Contact: telephone number **760-725-9454**

312100 UTILITY TRENCH DETAIL

Utility trenches shall conform to **SDRSD G24** and **G25** as required. *The utility trench work must be a two-step process:*

1. *First, the contractor must sawcut A/C pavement, excavate, install the pipe, and backfill while fulfilling other necessary procedures as specified on the drawings.*
2. *Second, the contractor must create a "T" section by cutting the trench edges to the depth of the existing asphalt concrete and to a width as specified on the drawings. If the existing asphalt-concrete depth is greater than 8" thick, the contractor will be allowed to grind to 4" depth and patch, keeping the minimum width of the trench edges.*

334000 STORMWATER

REFERENCES

All stormwater facilities shall conform to the most recent Unified Facilities Criteria (UFC) and Code of Federal Regulations (CFR) requirements. *The following references shall be used to design stormwater facilities at Camp Pendleton:*

1. *Energy Independence and Security Act (EISA), Section 438 (2007)*

2. *Technical Guidance on Implementing the Stormwater Runoff Requirements for Federal Projects under Section 438 of the Energy Independence and Security Act (EPA 841-B-09-001)*
3. *UFC 3-210-10, Low Impact Development*
4. *California Stormwater Quality Association (CASQA) Best Management Practice (BMP) Handbooks, latest edition [New Development and Redevelopment; Municipal; Industrial; Construction]*
5. *California Construction General Permit (Order 2009-0009-DWQ, NPDES No. CAS000002)*
6. *UFC 3-200-10n, Civil Engineering*

If the standard sought does not appear in the above requirements, then the latest edition of the following standards shall be used in the order listed. If a conflict exists, the Camp Pendleton Requirements have primacy.

7. *San Diego County Drainage Design Manual*
8. *San Diego County Hydrology Manual*
9. *San Diego County Standard Urban Stormwater Mitigation Plan (SUSMP)*
10. *UFC 3-230-17FA, Drainage in Areas other than Airfields*
11. *San Diego County Regional Standard Drawings*
12. *Standard Specifications for Public Works Construction (SSPWC or Greenbook)*
13. *CALTRANS, Standard Specifications and Construction Details, Stormwater Design Guidelines*
14. *Federal Highway Administration Urban Drainage Design Manual, Hydraulic Engineering Circular No. 22*

SUMMARY OF REQUIREMENTS

1. *Conceptual Overview*
A number of overlapping stormwater regulatory and engineering requirements apply to Camp Pendleton projects. Many of the regulations, policies and National Pollutant Discharge Elimination System (NPDES) permits require the use of Low Impact Development (LID) or Green Infrastructure techniques to manage stormwater. Basic principles of LID include managing stormwater on-site, as close as possible to the intaining pre-development hydrology using natural, passive drainage systems that mimic nature by allowing for maximum infiltration, filtration through vegetation, interception by plants or trees, evaporation and slow release of stormwater. Additional principles of LID include maintaining existing soils, contours, vegetation and natural channels, disconnection and minimization of impervious surfaces, designing the site with multiple, decentralized Best Management Practices (BMP), and minimizing compaction during construction. LID techniques are typically used to manage the stormwater from the smaller, more frequent storms, with the goal of reducing pollutant loads, improving water quality of receiving waters and preventing damage from erosion. In addition, traditional flood control measures must also be employed to protect people and property from large,

infrequent and potentially damaging flood events. Combining LID and flood control techniques ensures that both water quality and quantity are addressed during site design.

2. Regulatory Specifics

The Energy Independence and Security Act (EISA) Section 438 requires development or redevelopment projects involving a Federal facility with a footprint (area of soil) that exceeds 5000 square feet to use site planning, design, construction and maintenance strategies for the property to maintain or restore, to the maximum extent technically e-development hydrology of the property with regard to temperature, rate, volume and duration of flow. This can be achieved with LID techniques using the 95th percentile storm, or via a site-specific hydrologic analysis using continuous simulation modeling or other tools. The Department of Defense policy on implementing EISA (dated January 19, 2010) defines “pre-development” as “pre-project.” The Department of Navy LID Policy (dated 2007, and often referred to as the Penn Memo) established a goal of no net increase in sediment or nutrient loading for major construction and renovation projects, and this goal was incorporated into UFC 3-210-10. LID design may be used to meet Leadership in Energy and Environmental Design (LEED) stormwater credits which are also required by Department of Navy policy.

Similar LID requirements appear in California NPDES stormwater permits. The California General Construction Permit requires LID techniques be implemented for all projects which are under construction as of 2 Sep 2012. Documentation of LID design, including water balance calculations, must be submitted as part of the construction permit application process. California has also incorporated LID requirements in to the Large and Small Municipal Separate Storm Sewer (MS4) Permits. The state has provided notice that military installations will be required to enroll in the Small MS4 program when the upcoming final, revised Small MS4 permit is adopted. Implementation of LID techniques according to the requirements of this CPR will assist Camp Pendleton in complying with the Small MS4 permit when formal designation occurs. San Diego County is designated as a large MS4, and has developed much written guidance for stormwater management and design to comply with their permit obligations. While Camp Pendleton is not required to comply with County standards, much of the design information is useful as guidance. As stormwater regulations continue to increase, LID BMPs will likely be considered the state of the art in stormwater management.

DEFINITIONS

1. *Best Management Practices (BMP) – Structural and nonstructural methods of treating stormwater to prevent pollution.*
2. *Pre-development Hydrology – Pre-project hydrologic conditions of temperature, rate, volume and duration of stormwater flow.*
3. *95th Percentile storm – The storm event whose precipitation total is greater than or equal to 95 percent of all 24-hour storms on an annual basis.*
4. *2-year storm – The largest amount of rainfall expected over a specified duration occurring during a 2-year interval.*
5. *10-year storm – The largest amount of rainfall expected over a specified duration occurring during a 10-year interval.*
6. *Run-on – Stormwater which drains into a project area from off-site.*
7. *Engineered Soil Media – A specified mixture of sand, soil and organic compost.*

8. *Disconnection of impervious surfaces – Disconnecting paved areas from the stormwater system by directing surface runoff into infiltration BMPs or other means of reuse. Disconnecting roof areas by directing roof gutter downspouts to landscaping areas or infiltration BMPs rather than connecting directly into stormwater pipes.*

Contractors may request a copy of the CPEN Illustrated Guide to Stormwater Terminology for more information regarding specific BMPs (such as basins, bioretention areas, bioswales, cisterns, permeable pavement, buffers, etc.); inlet and outlet structures; pipes, culverts and headwalls; engineered channels; manholes and junctions; flow control structures; and energy dissipaters.

SUBMITTALS

1. Design Submittals
The following design submittals shall be provided to Public Works, divided into sections and in accordance with Section 013300. Larger submittals can be submitted on a data disk in PDF format. Electronic files must be organized with bookmarks or hyperlinks to simplify viewing.

Stormwater Report

The Stormwater Report will consist of the following three sections. Calculations shall include upstream contributing drainage system.

1. **Flood Control**
 - a. Hydrology and Hydraulics - *This section should follow the typical format in the San Diego County Manuals, which includes a cover page, table of contents, project discussion (boundary conditions, Manning's "n" value used, description of existing and proposed conditions, and summary tables), existing condition hydrology calculations, existing condition hydrology map, proposed condition hydrology calculations, proposed condition hydrology map, line hydraulics, water surface elevation calculations, inlet calculations, channel calculations, and energy dissipator calculations.*
 - b. Hydrograph and Flood Routing - *This section must be submitted for projects which include a flood control basin. The report should follow the format of the San Diego County Manuals, which includes a cover page, table of contents, project discussion (boundary conditions, description of existing and proposed conditions, and summary tables), existing condition hydrograph calculations, existing condition hydrology map, proposed condition hydrograph calculations, proposed condition hydrology map, outlet structure hydraulics, and emergency spillway calculations.*
2. **EISA 438 and Water Quality**
 - a. EISA 438 Design - *This section must be submitted for projects subject to EISA requirements. The summary should include an explanation/justification of LID design and supporting calculations and drawings. This section should include a summary of how the requirements of EISA 438 are being achieved. If EISA 438 option 1 is used, then the report must show that the 95th percentile storm is being retained on site. If EISA 438 option 2 is used, then the report must show that post-development condition does not increase flow rates, volume, duration or temperature above the pre-development condition. For projects where LID has been deemed technically infeasible, a waiver is subject to EISA requirements and must be approved by Public Works.*
 - b. Water Quality Design – *This section should follow the format of the San Diego County Standard Urban Stormwater Mitigation Plan (SUSMP). The facility's pollutants of concern should be identified and the clearly addressed through various BMP facilities. Each BMP facility must have design calculations showing proper sizing and acceptable O&M requirements. This section should include shop drawings for manufactured treatment and/or detention BMPs, and accessory equipment, including principal*

dimensions, filter placement, location of fittings and unit foundation. Include data to verify center of gravity with the unit empty and filled with water. Submit design flow calculations for manufactured treatment and/or detention BMPs, and include specification for type of media or filter. Submit manufacturer's certifications/qualifications, instructions, and operations and maintenance requirements.

- c. Geotechnical Engineering - Site-specific geotechnical investigation shall be attached to the Water Quality Report. Geotechnical investigation must include sufficient borings, in-situ infiltration testing and/or laboratory soil characterization in order to adequately characterize surface soil and subsoil properties in each area of the site, and should address the potential presence of an impermeable layer. These soil properties must be used in LID design, as well as in Construction Stormwater Permit risk determination (if permit is required).

3. Schematic Stormwater Design and Cost Estimate

- a. Integrated Site Plan – The schematic stormwater site plan should graphically illustrate the overall stormwater concept for the project. This plan shall be a product of the Concept Design Workshop and shall be interdisciplinary. Its purpose is to integrate the architectural, landscape, and engineering designs as they relate to stormwater and overall site design. The plan shall include: all roof runoff locations and type (downspout, sheet flow, etc.), all surface and subsurface flows (indicate if sheet flow, channelized, piped, etc.), locations and types of infiltration areas and all general LID BMPs, and basic design concepts (formal and informal areas, educational/information opportunities, etc.). The plan should refer to and complement the Flood Control and Water Quality Sections. The plan shall incorporate the recommendations of Public Works' camp-by-camp drainage studies if available.
- b. Cost Estimate – A cost estimate of the stormwater facilities should accompany the schematic. The cost should include construction costs as well as ongoing maintenance costs, such as the price of filters for manufactured devices.

Closeout Submittals

Closeout documents must be submitted in accordance with Section 017830, and must include the following elements:

- a. Operation and Maintenance manuals for all stormwater BMPs, plus manufacturer's specifications and warranty for manufactured treatment/detention BMPs;
- b. Pre-operational and in-service test results for manufactured treatment/detention BMPs, including inspection reports from the maintenance period and photographs taken during the respective inspection;
- c. Pre-operational and in-service infiltration test results for infiltration BMPs;
- d. Warranty inspection reports and photographs for stormwater facilities.
- e. Construction Permit documents (if permit is required): redlined Stormwater Pollution Prevention Plan (SWPPP), and all permit-required submittals, including inspection and sampling records, exceedance reports, Notice of Intent, Notice of Intent Acceptance Letter, Certification Statements, Notice of Termination, Notice of Termination Acceptance Letter, Annual Report.

334001 STORMWATER DESIGN STANDARDS

STORMWATER DESIGN

The San Diego County Hydrology Manual and the County of San Diego Drainage Design Manual shall be used for stormwater design, including the required design storm duration/frequency, methodology, and capacity, except as provided below.

1. Water Quality, Water Quantity and Low Impact Development
Camp Pendleton is included on the isopluvial maps necessary to follow the County of San Diego procedures, and the 85th percentile storm should be used for water quality

(treatment control) design. If there is a pollutant of concern associated with the project, then water quality BMPs must remove the pollutant to a high level (above 75%). All other pollutants should be removed to the maximum extent practicable, but should at a minimum remove pollutants at a medium level (above 50%). EISA requires the 95th percentile storm. For water quantity design, EISA 438 must be followed, and is primarily implemented via LID. The 95th percentile depth is 1.5", which was calculated using data from the MCAS Pendleton rain gage. Site specific calculation of the 95th percentile event is acceptable, but must be reviewed and approved by Public Works. EISA 438 option 2 requires that the hydrographs of the pre-development condition and the post-development condition match. Special attention should be given to the EISA 438 requirement for volume and duration since these are highly dependent upon soil conditions. See CASQA Stormwater Best Management Practice Handbook for New Development and Redevelopment for additional siting and design considerations. Run-on shall be routed around, through or under site, or detained upstream so that LID design may be limited to runoff generated on-site.

2. Flood Control

Flood control basins shall be designed such that the storage volume and the flow control outlet structure, at a minimum, manage increases in the peak discharge rates for both the 2-year and 10-year storm events. If the site will affect critical facilities or major roadways downstream, then the site should detain the 100-year storm event in addition to the 2-year and 10-year storm events. Flood control basins shall be sited upstream of eas where possible, to intercept water entering the camps and protect critical facilities from flooding. Inlets on roadways shall be designed to comply with the Federal Highway Administration Urban Drainage Design Manual, Hydraulic Engineering Circular No. 22, latest edition, in order to ensure minimum spread.

If there is a conflict between EISA, LEED, Department of Defense/Department of Navy LID Policies, County of San Diego standards or State of California regulations, then the more stringent design requirement will be used.

334002 STORMWATER COLLECTION/CONVEYANCE SYSTEM

CAPACITY, SLOPE, RADIUS, ALIGNMENT, SETBACK, COVER

1. The County of San Diego Hydrology Manual and the County of San Diego Drainage Design Manual shall be used to determine the design standards for pipe capacity. Minimum pipe diameter shall be 6 inches. Minimum pipe diameter for main lines shall be 24 inches. Minimum pipe diameter for laterals shall be 18 inches. Pipe capacity shall not decrease in the direction of flow. Minimum bend radius shall be 22.5 feet. Minimum longitudinal pipe slope shall be above 0.5% and minimum velocity shall be 2.5 ft/sec. Slope less than 0.5% is allowable for engineered channels. Side slope for earthen channels shall not be steeper than 3H:1V. Stormwater pipe must not pass under buildings and must be set back a minimum of 10 ft from building foundations. Minimum pipe cover shall be 12 inches. All pipes shall be designed with sufficient cover to bear surface loads. Stormwater pipes shall have a 4 ft horizontal separation distance and a 1 ft vertical separation distance from potable water pipes and wastewater pipes, with potable water pipes on top.

CONVEYANCE

- 1.. Stormwater shall be conveyed to the next downstream stormwater facility, if existing, or to a nearby drainage channel or creek. If stormwater is released to the street, the designer must show that the gutter, if existing, has capacity. Where downstream capacity of existing stormwater pipe or engineered channel within the project boundary is insufficient to convey the design flow, the downstream capacity shall be increased. This

does not apply to natural channels. Where downstream engineered conveyances are damaged or unable to pass design flows, these conveyances shall be repaired or replaced. In the event that the downstream undersized or damaged stormwater facility is located outside of the project boundary, the boundary can be amended to correct the drainage problem, but Public Works shall decide the appropriate course of action and obtain required environmental approvals. If existing pipes cannot adequately convey increased post-construction peak flood flows, then the site must detain to the preconstruction level. If downstream channels will be damaged by increased peak flows, then the site must detain to the preconstruction level. Off-site run-on shall be included in the site design. Run-on may either be detained upstream or routed around or through the site drainage system. Existing natural channels should be preserved wherever possible. Additional requirements related to natural channels can be found in the project's environmental documentation.

PIPE MATERIAL

1. All stormwater piping outside of cantonment areas (such as undeveloped areas susceptible to wild fires) shall be Reinforced Concrete Pipe (RCP). Stormwater piping within cantonment areas shall be RCP or corrugated high density polyethylene (HDPE) pipe. Underdrains shall be constructed of perforated plastic drain pipe, constructed within a washed gravel layer. Underground detention structures may be corrugated metal pipe (CMP), RCP or HDPE. CMP may be used for risers. Galvanized metal pipes shall be avoided, however if necessary, galvanized pipes with protective coating may be used (per CNRSW policy dated 27 Apr 2006). All pipe materials shall have a minimum service life of 60 years. Service life of CMP shall be confirmed by Geotechnical Report using resistivity tests of the soil in which the pipe shall be placed.

CHANNEL MATERIAL

1. Vegetated or rock-lined channels are preferred. If not possible, engineered channels may be constructed of concrete. Asphalt channels are prohibited.

UTILITY LOCATION

1. Tracer tape shall be installed on stormwater pipes to enable future underground utility location. Stormwater pipe tape shall be green with the words, "CAUTION: BURIED STORM DRAIN LINE BELOW", in black ink. The tape shall be installed 6" to 12" below grade in the excavation ditch and should conform to the following standards:
 - NTSB-PSS-73-1
 - GSA Public Buildings Service Guide
 - American Gas Association 72-D-56
 - API RP 1109
 - OSHA 1926.956 (c) (1)
 - APWA Uniform Color Code
 - DOT Office of Pipeline Safety USAS B31.8
 - Federal Gas Safety Regulations S 192-321 (e)

CULVERTS

1. Concrete arch or box culverts shall be used in natural channels to allow maximum flows to pass unobstructed. Metal arches are also acceptable. One or more round, box or arch culverts may be used in small engineered channels. Elliptical culverts are allowable when existing conditions do not allow the installation of circular culverts.

HEADWALLS

1. *All culvert entrances and exits will be installed with concrete headwalls. Headwalls with flared wingwalls, headwalls with parallel wingwalls and mitered-end headwalls are allowable. Straight headwalls are prohibited. Concrete apron slabs are allowed in conjunction with headwalls.*

ENERGY DISSIPATION

1. *Energy dissipators shall be designed and sized to reduce the scouring potential of stormwater at the design flow rate at the inlet and outlet structures. The use of gabions is not desirable and must be approved by Public Works on a limited case by case basis. For pipes which discharge to a vegetated channel, outlet velocity should not exceed 5 ft/sec. If the outlet velocity exceeds 5 ft/sec, erosion protection must be implemented.*

MANHOLES AND JUNCTIONS

1. *Manhole cover shall be inscribed with the words "STORMWATER" or "STORM DRAIN" in order to delineate between storm sewer manholes and sanitary sewer manholes. Design of manholes and junction boxes shall comply with County of San Diego standards. Junction angles should be 45 degrees or less. Manholes should be placed at mainline junctions, at changes in horizontal or vertical alignment of pipe, and at the following intervals: every 300 feet for pipes of diameter 24 inches or less; every 400 feet for pipes of diameter 24 to 48 inches; every 500 feet for pipes of diameter greater than 48 inches in diameter.*

INLET AND OUTLET STRUCTURES

1. *Water shall be released at grade. Waterfall pipe outlets are prohibited. Grate-top drop inlets, curb inlets, box-top inlets, surface linear inlets and riser outlets are allowable. Open-pipe inlets and outlets must be accompanied by a headwall. Outlet structures may be designed with weir plates, orifices or gates to produce the design discharge flow rate. Grate inlet covers must use "bicycle proof" design where appropriate. In landscaped areas or vegetated BMPs, elevated brass atrium or beehive-style grates may be used to prevent mulch from blocking inlets and outlets. Detention basins and infiltration basins shall be designed with an emergency overflow to limit damage to the basin and to downstream facilities.*

DOWNSPOUT

1. *Stormwater from downspouts (roof drains) shall be controlled and routed away from the building to a nearby stormwater BMP or landscaped area. The route from the downspout to the stormwater BMP can be aboveground or underground. The route should not cross over or drain onto a sidewalk, walkway or patio area. Downspouts should not be directly connected to the conveyance system (pipes, catch basins, etc) unless the conveyance discharges to a stormwater BMP."*

334003 GEOTECHNICAL CONSIDERATIONS FOR STORMWATER

SOIL PROPERTIES

1. *Where existing soil properties do not provide sufficient infiltration rates, infiltration BMPs may be designed using imported engineered soil media and/or underdrains. Engineered soil must be specifically developed to be sufficiently permeable to infiltrate runoff at a design rate of 1 to 5 inches per hour and have sufficient moisture retention to support healthy, vigorous plant growth. Engineered soils shall be a mixture of 85-88% sand, 8-*

12% fines and 3-5% organic matter. Design infiltration rate and soil mix may be modified based upon site conditions and targeted pollutant(s) and must be tested to meet above objectives. Engineered soil must have a Phosphorus Index less than or equal to 30. Where infiltration BMPs will be used, consideration must be given to the potential presence of subsurface impermeable layers and the relative likelihood that infiltrated water may migrate to alternate pathways such as structures, roadways, or utility trenches, and the site shall be designed to avoid damage to those facilities.

SLOPE PROTECTION

1. A slope of 3H:1V is preferred for hillside cuts within cantonment areas, however a slope of 2H:1V is allowable. If a steeper slope is proposed, a geotechnical engineering analysis must be provided to justify that the recommended slope will be sufficiently stabilized. Water shall be intercepted at the top of slope and conveyed safely down the slope by means of a concrete brow ditch. Outlet will be placed beyond the toe of slope so as to avoid eroding the toe of slope.

PERMANENT STABILIZATION

1. Permanent stabilization and establishment of vegetation must be demonstrated prior to termination of construction permit (if permit is required) and prior to contract closeout.

EXTERIOR FOUNDATION

1. Finished grade shall slope away from exterior foundations at a minimum of 2% to maintain positive drainage to a stormwater facility.

334004 STORMWATER BEST MANAGEMENT PRACTICES (BMP)

ACCEPTABLE BMPS

1. The following table contains a complete listing of BMPs which will be allowed for each type of facility. Specific restrictions on the use of each type of BMP are detailed below the table. Public Works may approve BMPs that are functionally equivalent to those in the table on a case-by-case basis.

PROHIBITED BMPS

1. BMPs not listed in the table are prohibited. Prohibited BMPs include Green Roofs, Infiltration Wells and Injection Wells. Any BMP which would require an individual discharge or drilling permit is prohibited.

FACILITY CATEGORY	ALLOWABLE BMP	
Administrative and Instructional Facilities: Offices, Classrooms, Schools, Child Development Centers	Bioswale/Bioreten-tion Area	Detention Basin
	Permeable Pavement	Vegetated/Riparian Buffer
	Cistern	Manufactured Treatment BMPs
	Infiltration Trench or Basin	Manufactured Detention BMPs
Lodging Facilities or Quarters: Bachelor Enlisted Quarters, Bachelor Officer Quarters, Temporary Lodging	Bioswale	Detention Basin
	Bioretention Area	Vegetated/Riparian Buffer

	<i>Permeable Pavement</i>	<i>Manufactured Treatment BMPs</i>
	<i>Infiltration Trench or Basin</i>	<i>Manufactured Detention BMPs</i>
Light Industrial Facilities: <i>Gas Stations, Tactical Vehicle Maintenance and Storage, Armories, Wash Racks</i>	<i>Detention Basin</i>	<i>Vegetated/Riparian Buffer</i>
	<i>Manufactured Treatment BMPs</i>	<i>Catch Basin Hydrocarbon Filters</i>
Medical and Dental Clinics	<i>Bioswale</i>	<i>Detention Basin</i>
	<i>Bioretention Area</i>	<i>Vegetated/Riparian Buffer</i>
	<i>Permeable Pavement</i>	<i>Manufactured Treatment BMPs</i>
	<i>Infiltration Trench or Basin</i>	<i>Manufactured Detention BMPs</i>
High Volume Parking Lots: <i>More than 50 Parking Spaces</i>	<i>Bioswale/Bioretention Area</i>	<i>Detention Basin</i>
	<i>Permeable Pavement</i>	<i>Catch Basin Hydrocarbon Filters</i>
	<i>Vegetated/Riparian Buffer</i>	<i>Manufactured Treatment BMPs</i>
	<i>Infiltration Trench or Basin</i>	<i>Manufactured Detention BMPs</i>
Low Volume Parking Lots: <i>50 Parking Spaces or Less</i>	<i>Bioswale</i>	<i>Detention Basin</i>
	<i>Bioretention Area</i>	<i>Vegetated/Riparian Buffer</i>
	<i>Permeable Pavement</i>	<i>Manufactured Detention BMPs</i>
	<i>Infiltration Trench or Basin</i>	<i>Manufactured Treatment BMPs</i>
Recreational Facilities: <i>Fitness Centers, Golf Courses, Equine Facilities, Movie Theaters, Bowling Centers, Skeet and Trap Areas</i>	<i>Bioswale</i>	<i>Detention Basin</i>
	<i>Bioretention Area</i>	<i>Vegetated/Riparian Buffer</i>
	<i>Permeable Pavement</i>	<i>Manufactured Treatment BMPs</i>
	<i>Infiltration Trench or Basin</i>	<i>Manufactured Detention BMPs</i>
Retail Facilities: <i>Exchange, Home Center, Garden Center , Mini Exchanges, Apparel or other Shops</i>	<i>Bioswale</i>	<i>Detention Basin</i>
	<i>Bioretention Area</i>	<i>Vegetated/Riparian Buffer</i>
	<i>Permeable Pavement</i>	<i>Manufactured Treatment BMPs</i>
Food Service Establishments: <i>Restaurants, Dining Halls, Vendors</i>	<i>Infiltration Trench or Basin</i>	<i>Manufactured Detention BMPs</i>
	<i>Bioswale</i>	<i>Detention Basin</i>
	<i>Bioretention Area</i>	--
	<i>Permeable Pavement</i>	<i>Manufactured Treatment BMPs</i>
Exterior Common Areas: <i>Muster Areas, Parade Decks, Plazas, Sidewalks</i>	<i>Vegetated/Riparian Buffer</i>	<i>Manufactured Detention BMPs</i>
	<i>Bioswale</i>	<i>Detention Basin</i>
	<i>Bioretention Area</i>	<i>Vegetated/Riparian Buffer</i>

	Permeable Pavement	Manufactured Treatment BMPs
	Infiltration Trench or Basin	Manufactured Detention BMPs
Training Facilities within Cantonment Areas: Rappel Towers, Obstacle Courses	Bioswale	Detention Basin
	Bioretention Area	Vegetated/Riparian Buffer
	Infiltration Trench or Basin	--

BMP SPECIFICS

1. **Infiltration BMPs** include the following: **Bioswales; Bioretention Areas; Permeable Pavement; Infiltration Trench; Infiltration Basin.** Infiltration BMPs are preferred unless site conditions do not allow their use. In order to prevent siltation and clogging of the soil voids, Infiltration BMPs shall be protected from sediment-laden inflows, and located such that runoff from bare soil areas, including training roads, cannot enter the BMP. Berms or curbs shall be used to control entry of runoff to infiltration BMP.

Vegetated swales and filter strips may also be used to pre-treat, collect sediment, and slow water movement into bioswales, bioretention areas, permeable pavement, infiltration trenches, and infiltration basins. Infiltration BMPs should treat runoff from impervious areas only. Infiltration BMPs should not be used in industrial areas, in areas where hazardous materials are handled or stored, or where spills or leaks are likely to occur. The San Diego Regional Water Quality Control Board requires 10 ft of vertical separation between the bottom of the BMP's infiltration zone and groundwater.

2. **Permeable Pavement:** Permeable Pavement includes pavers, permeable asphalt and pervious concrete. Permeable pavement may be used in parking spaces, with traditional pavement in traveling lanes. For low volume parking lots (50 parking spaces or less), permeable pavement may be used in the traveling lanes. It may also be used in plazas, sidewalks and parade decks. Permeable pavement may not be used in high vehicular traffic areas or tactical vehicle parking areas. All requirements applying to infiltration BMPs also apply to permeable pavement.
3. **Detention Basin:** May be used as part of a system of BMPs, or for flood control purposes. A basin alone does not qualify as LID.
4. **Stormwater Wetland/Pond:** Due to the large land area required, and potential natural resources concerns, constructed wetlands and ponds must be approved by Public Works on a case by case basis.
5. **Vegetated Buffer or Riparian Buffer:** Vegetated buffer areas (filter strips) may be planted, or existing vegetated areas may be maintained, to slow down and filter runoff and prevent erosion. A riparian buffer is the naturally vegetated corridor along a stream. Existing riparian buffers shall be preserved whenever possible. Buffers shall not be placed in terrain that is too steep and/or in an area with an excessively large tributary area that will cause erosive flows.
6. **Cistern (rain barrel):** Cisterns may be used to capture and reuse rainwater from building roofs. The use of a cistern requires approval by Public Works and will be determined on a case-by-case basis in the following limited circumstances: Cisterns will only be used where there will be a continuing, on-site use for water; where the cistern

can serve a dual educational/public awareness purpose; and where the project sponsor has committed to use of the cistern. The design of cisterns shall provide a visible reminder of water conservation/stormwater goals. Cisterns may be underground or aboveground. Some level of minimum treatment may be required, depending upon the planned re-use.

7. **General LID BMPs:** General LID practices include disconnected downspouts, disconnected and minimized impervious surfaces, maintaining existing soils, contours, vegetation and natural channels, and use of vegetated buffers. These BMPs are desirable at all types of facilities.
8. **Manufactured Treatment BMPs:** Manufactured treatment BMPs consist of filters, cartridges, separators, media or inserts, used individually or in combination, and housed within an underground vault or manhole, used for the purpose of treating stormwater and removing pollutants prior to discharge. The specific type of treatment unit must be designed to treat the pollutants expected to be generated at the facility. These units may be used in the following circumstances: where permanent site activities will be industrial or commercial in nature; or where site conditions do not allow the use of infiltration BMPs. Manufactured treatment BMPs are less desirable than other BMPs and shall be avoided wherever possible. Small, individual catch basin hydrocarbon filters may only be used in high volume parking lots and industrial facilities.
9. **Manufactured Detention BMPs:** Manufactured detention BMPs, consisting of underground concrete, HDPE or CMP pipe galleries or chambers, may only be used at sites with extreme space limitations. Due to the difficulty of accessing these underground detention systems for maintenance, manufactured detention BMPs must be preceded by a pretreatment BMP designed to remove sediment, spills and any other pollutant of concern at the site. Manholes shall be included at 100 ft intervals, junctions or other reasonable locations to allow for maintenance of underground detention systems. Underground detention shall not be used at industrial facilities.
10. **BMP SITING, DESIGN AND CONSTRUCTION REQUIREMENTS**

BMPs shall be integrated into other functional components of the site, such as the landscaping and infrastructure, without impeding or significantly affecting their function. Stormwater shall not be allowed to accumulate at building foundations. BMPs will be customized to adapt to the physical constraints of the site, such as available open space, facility use and function, degree of soil compaction, microclimate, and the location of sewers, utilities, and the groundwater table. Infiltration BMPs, permeable pavement and detention basins should not be sited on hillside slopes. Public Works may approve on a case-by-case basis if documentation of appropriate site-specific soil characteristics is provided. BMPs will be designed to intercept and/or treat stormwater near the source. BMPs will be designed to meet the stormwater management objectives of a specific site. This includes addressing pollutants of concern of the specific site, as well as addressing pollutants of concern (impairments) in nearby water bodies. BMPs will be designed to minimize concentrated flows to reduce downstream erosion and maintain surface hydrology.

Storm drains shall not be sited downslope of, or immediately adjacent to, loading docks, garbage dumpsters or hazardous materials/waste storage areas unless appropriate treatment and/or containment are provided. Storm drains shall be stenciled using the approved Camp Pendleton storm drain stencil. Restaurants shall provide a janitorial area with sanitary sewer floor drain and grease interceptor for washing floor mats and disposing of mop water. For indoor maintenance or industrial areas, trench drains are not desirable, however if required, shall be dead-end containment trenches only, and shall not be connected to the sanitary sewer or to the storm drain system. Parking structure floor drains shall be connected to the sanitary sewer system.

Proper construction sequencing shall be used such that Infiltration BMPs shall not be installed until the drainage area has been stabilized, so as to prevent damage/siltation of BMP during construction. Similarly, proper construction sequencing shall be used such that site soils in the vicinity of infiltration BMPs do not become compacted during construction.

334005 MANUFACTURED TREATMENT AND DETENTION BMPS

1. **ACCEPTABLE MANUFACTURED BMPS:** Where no other BMP options are feasible, manufactured BMPs may be selected. Manufactured BMPs shall conform to the following requirements. Manufactured treatment systems must be capable of removing the specified pollutants to a high efficiency. Manufactured systems shall be designed to be as simple as possible, with a minimum number of components. The system shall not include moving parts. Replacement parts, such as filters or media, shall be commercially available. Plan drawings for the specific model shall be provided. Selected system must be functionally equivalent to existing systems on base so as to minimize maintenance requirements. Manufactured underground detention systems must be properly designed for aboveground structural loads.
2. **PROHIBITED MANUFACTURED BMPS:** Proprietary/manufactured systems which would obligate the Government to obtain replacement parts or services from a single vendor are prohibited. Systems requiring a pump are prohibited. Systems requiring the use of chemicals are prohibited. Systems requiring maintenance more than twice per year are prohibited. Systems requiring permit- required confined space entry for maintenance shall be avoided unless absolutely necessary. Limited exceptions for industrial facilities must be approved by Public Works
3. **MANUFACTURER/INSTALLER'S QUALIFICATIONS**
Prior to installation, the contractor shall submit proof of manufacturer/installer's experience and qualifications which shall include three years on projects of similar complexity. Documentation must include names and locations of two projects successfully completed and proven to perform as specified.
4. **DELIVERY, STORAGE, AND HANDLING**
Manufactured unit materials shall be inspected for damage upon delivery. Materials stored on-site shall be housed in an enclosure or under protective coverings. Materials shall not be stored directly on the ground.
5. **INSTALLATION**
Manufactured unit and accessory equipment shall be installed in accordance with manufacturer's recommendations. Unit shall be leveled and anti-flotation ballast shall be installed to prevent hydrostatic uplift and ensure unit stability. Each item of equipment shall have a nameplate bearing the manufacturer's name, address, model name and number, and serial number securely affixed in a conspicuous place. The nameplate of the distributing agent will not be acceptable. Cartridges/ filters/media shall not be installed until the drainage area is clean and stabilized.

334006 WARRANTY, TESTING AND INSPECTION OF STORMWATER FACILITIES

WARRANTY

1. Provide one-year warranty on all stormwater facilities, including LID features and manufactured treatment/detention systems, as well as all landscaped areas. The warranty period shall be for 365 calendar days. The warranty period shall begin on the Basic Occupancy Date (BOD) of the contract, or for projects with a construction permit,

the warranty period shall begin upon acceptance and approval of the Notice of Termination by the Regional Water Quality Control Board, whichever occurs later.

2. *The following stormwater facility maintenance activities shall be completed prior to BOD: trash and debris removal, sediment removal, weed/brush removal, cartridge, media and/or filter replacement, street sweeping and/or vacuuming of pavement areas, system flushing or other maintenance required for proper function of the BMP. All impermeable surfaces shall be clean and free of dirt and debris. All catch basins, manholes and pipes shall be free of dirt and sediments. Erosion damage shall be repaired during maintenance period. For manufactured BMPs with a separate one-year warranty, cartridge, media and/or filter replacement and other provided maintenance shall be as directed by the manufacturer and at a minimum, mandatory at the end of the warranty period.*
3. *Stormwater facility warranty maintenance shall be integrated with Landscape Maintenance for all vegetated BMPs. Landscape maintenance contractor shall be familiar with the design and function of the specific stormwater measure(s) to ensure proper function of stormwater BMPs. Chemical applications are prohibited. Landscape Maintenance Log shall be used to document all landscape maintenance actions in vegetated BMPs during the warranty period. Refer to BEAP Section 3.6 D LANDSCAPE GUIDELINES, Maintenance and Establishment Period.*

FIELD QUALITY CONTROL TESTING AND INSPECTIONS

1. *The Contracting Officer shall witness field tests and conduct field inspections specified in this section. The Contractor shall perform field tests and provide labor, equipment, and incidentals required for testing. The contractor shall produce evidence, when required, that each item of work has been constructed in accordance with the drawings and specifications. The contractor shall submit written documentation of results, including photographs, after each quality control test or inspection.*
2. *Pre-operational and in-service tests shall be conducted to ensure proper installation and functioning of stormwater BMPs. For manufactured treatment/detention BMPs, the manufacturer's service representative is required to be present and certify successful completion of tests. For infiltration BMPs, pre-operational and in-service tests shall consist of in-situ infiltration testing or other verification of design infiltration rate. Pre-operational tests shall be conducted prior to BOD. In-service tests shall be conducted at the 11 month warranty site walk. Test results shall be documented.*
3. *During the warranty period, the contractor shall conduct a minimum of two physical inspections of each stormwater facility, including all BMPs. The first stormwater facility inspection shall be conducted after a significant storm event or at the end of the rainy season. The second stormwater facility inspection will be conducted near the end of the warranty period, preferably after a significant storm event or at the end of the rainy season. Landscape warranty inspections will be conducted concurrently for vegetated BMPs. Corrective actions required as a result of inspections shall be completed during the warranty period, and coordinated with the ROICC Office and Facilities Maintenance Department Quality Assurance inspector. Inspection results shall be documented and photographed.*

334007 SPECIAL CONSIDERATIONS FOR STORMWATER

MAINTENANCE AND ACCESS

1. *Site design should minimize long-term maintenance costs. See CASQA Stormwater Best Management Practice Handbooks for maintenance considerations. Site design shall*

include maintenance access points which allow maintenance personnel and heavy equipment safe access to stormwater collection and conveyance system, including BMPs, basins and manholes/junctions. Some underground structures may require multiple manholes in order to provide maintenance access for personnel and/or equipment such as vacuum trucks. Maximum pumping height and distance shall be considered for BMPs requiring maintenance by vacuum truck. Access ramp and entry road must be provided for flood control basins. Forebays should be designed as sediment cleanouts to reduce maintenance of basins

2. *Vault doors/manholes and access ladders shall be installed in all underground manufactured treatment vaults. Each door shall be equipped with a recessed lifting handle and a locking latch or other means to securely close.*

SAFETY

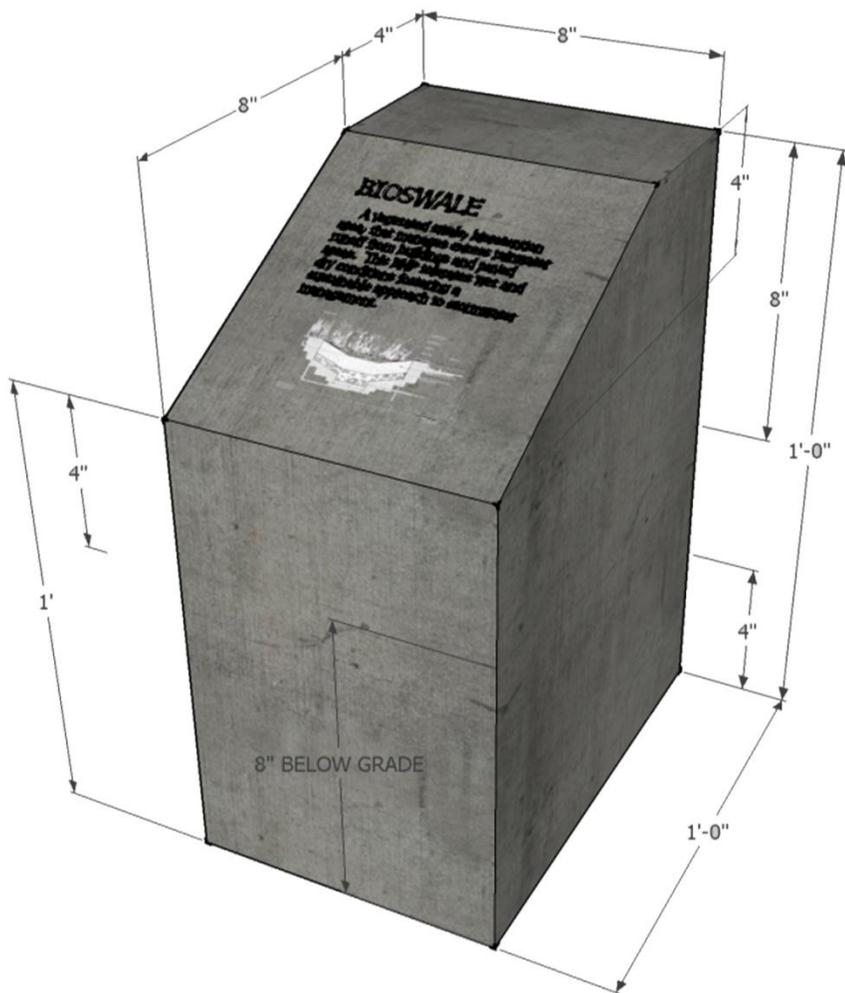
1. *Roadside conveyances should be designed with appropriate separation or physical barrier so as to minimize the possibility of vehicle accidents. Metal debris rack, fencing or other protective measures should be provided for stormwater facilities located in areas likely to be frequented by pedestrians. Rack should be sized to maintain pipe capacity while preventing access to pedestrians. Standing water has the potential to harbor mosquitoes, therefore stormwater facilities must be designed to infiltrate or drain completely within 72 hours.*

PHYSICAL SECURITY

1. *Provide security barriers at all locations where perimeter security fences must cross drainage channels or culverts to prevent access by intruders. Designs must comply with UFC 4-010-01, DoD Minimum Antiterrorism Standards For Buildings and UFC 4-010-02, DoD Minimum Antiterrorism Standoff Distances For Buildings. When conflicts arise between LID/EISA and UFC 4-010-01 or 4-010-02, UFCs 4-010-01 and 4-010-02 take precedence.*

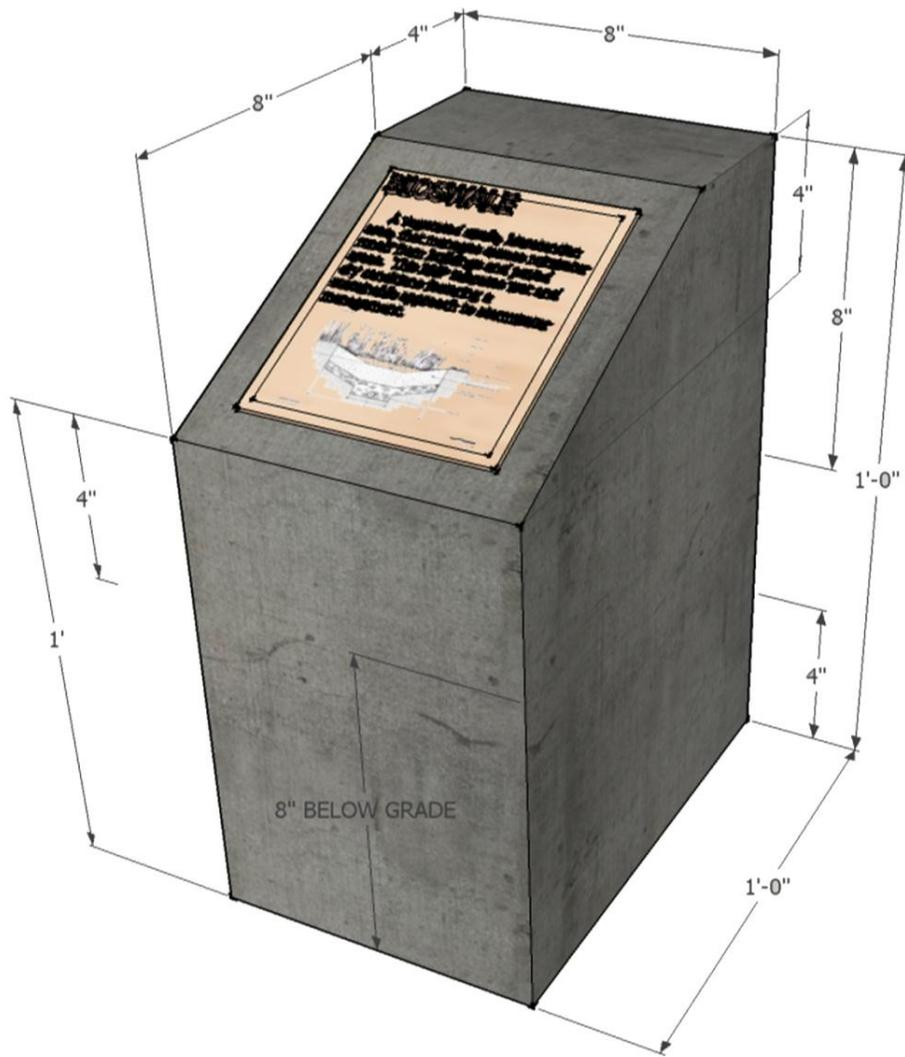
SIGNAGE

1. Required Signage
Signage prohibiting tactical or recreational vehicle use shall be installed near applicable BMPs. Signs shall be constructed of durable exterior materials and shall be warrantied for a period of at least five years. Signs shall be designed in accordance with the recommendations in the Base Exterior Architecture Plan and shall conform to any other base signage requirements from the Facility Maintenance Department.
2. Optional Signage
An interpretive sign covering the key site LID components may be installed where the sign can serve a dual educational/public awareness purpose. Interpretive signs may be used to meet LEED requirements. The use and content of an interpretive sign requires approval by Public Works and will be determined on a case by case basis. Interpretive sign shall be placed in high foot traffic areas, at an appropriate viewing location, either indoors or outdoors. Outdoor signs shall be constructed of durable exterior materials and shall be warrantied for a period of at least five years. Interpretive signs shall be limited to the following options:



BMP SIGNAGE DETAIL

ENGRAVED BMP SIGNAGE



COPPER PLAQUE BMP SIGNAGE

334008 BASE EXTERIOR ARCHITECTURE PLAN (BEAP) CONSIDERATIONS FOR STORMWATER BMPs

LANDSCAPE AND PLANTING DESIGN

1. All landscape areas shall conform to the BEAP unless specifically outlined otherwise in this document. Plants play a very important role in natural drainage patterns, and landscape-based stormwater treatment (vegetated BMPs) is encouraged as an effective, aesthetic, and relatively simple way to achieve LID goals. Plants can be used to aid in infiltration and evapotranspiration, sedimentation, pollutant trapping, phytoremediation, and soil stabilization. Given these varying and important functions, each planting plan shall be carefully designed and shall be site and BMP specific with the long term goal of naturalization. Ability to tolerate heat, coastal conditions, flooding and wind should also be considered.

SITE DESIGN

1. *The design intent shall be to integrate vegetated BMPs into the greater site and landscape design. The intent of vegetated BMPs is to mimic natural systems. Techniques to achieve this include natural contour grading, diversity of species, and full coverage of slopes. Having a cross disciplinary team (landscape architect, civil engineer and architect, etc.) involved from conceptual planning through design and construction will ensure a more unified design. Existing vegetation shall be maintained where possible to serve as a buffer.*

PLANT SELECTION

1. *The Camp Pendleton Approved Plant list was developed using plants with characteristics such as drought-tolerance, lack of invasive potential, and minimal maintenance demands, and which are suitable in the different micro-climates and low soil fertility found on Camp Pendleton. Plants used in vegetated BMPs must meet these criteria, and also must tolerate periodic inundation, be adapted to well-drained soils, have phytoremediation capabilities, and not have invasive roots. Observation of the surrounding natural landscape, design that mimics plant communities, biodiversity, and overall durability should drive the planting design. Not every species is appropriate for every site.*
2. *Vegetated BMP area shall contain an appropriate mix of trees, shrubs and herbaceous perennial ground cover. Containerized plants or plugs shall be used in vegetated BMP areas. Seeding is unreliable due to the fluctuating water levels that are typical in BMPs, and should therefore not be used in inundation areas or in the flow pathway. Plant spacing shall be dense in order to achieve quick soil coverage. A density of one tree or shrub per 50 square feet of vegetated BMP areas is the desired average, with herbaceous perennials between. Additional details on plant spacing may be found in the request for proposal. A mix of at least three species in each category shall be used in order to avoid the development of monoculture. Trees shall be kept to the periphery of the planting area and be placed so as to provide shade for the greater landscape as necessary. All plants should be placed in order to function properly in terms of filtration and retention, but also should be integrated into the aesthetics of the site design. Full coverage of ground cover must be achieved by end of warranty period.*

IRRIGATION

1. *Permanent, automatic, below-ground irrigation is required in all landscaped areas and bioretention facilities. Irrigation shall conform to current BEAP and CPR standards. Temporary aboveground irrigation systems may be used for seeded or hydroseeded areas as approved by the Public Works Department. Irrigation systems must be designed to minimize water use, avoid overwatering, and prevent underdrain discharges during dry weather. Spray heads must be positioned to avoid direct spray into outlet structures or onto paved surfaces.*
2. *Vegetated BMPs may need to be irrigated more than once a day. Irrigation schedules shall be designed to operate in a series of short cycles, rather than one longer cycle. This aids in water penetration and minimizes run-off. Irrigation controls shall allow separate zone control of times and durations of irrigation for vegetated BMPs vs. other landscape areas. Contractor shall confer with Public Works Department to determine if recycled wastewater is available at project site and if it will be allowed in vegetated BMPs.*

FERTILIZATION

1. *Due to the potential for conveying nutrients to storm drains, no fertilizer should be added to vegetated BMPs or landscape areas that drain into them. Compost tea, available from various nurseries and garden supply retailers, may be applied at a recommended rate of 5 gallons mixed with 15 gallons of water per acre.*
2. *Compost tea can be applied up to two weeks prior to planting and once per year between March and June. Application is not recommended when temperatures are below 50 F or above 90 F or when rain is forecast in the next 48 hours. Additional applications may be needed to correct nutrient deficiencies.*

MULCH

1. *Mulch is required for the purpose of retaining moisture, preventing erosion and minimizing weed growth. Rock mulch (gravel) shall be used in the flow path of stormwater and where complete plant cover is not expected. When using organic mulch in vegetated BMPs, aged mulch, also called composted mulch, shall be used to reduce the tendency to float into overflow inlets during intense storms. Organic mulch may be used in the ponding areas. Organic mulch shall not be used in the primary flow path of stormwater. Mulch shall be at least 3 inches thick to prevent weed growth.*

WEED CONTROL

1. *During the maintenance period, weeds should be controlled primarily by manual methods and soil amendment. In response to problem areas or threatening invasions, corn gluten, white vinegar, vinegar-based products, or non-selective natural herbicides may be used. Weed fabric should not be used in vegetated BMPs.*

PEST AND DISEASE CONTROL

1. *Synthetic pesticides should not be used on bioretention facilities. Beneficial nematodes and non-toxic controls may be used.*

REFERENCE STANDARDS

COUNTY OF SAN DIEGO STANDARDS – MOST CURRENT EDITION

1. Concretes Structures
2. Drainage Systems: Details D-30 to D-34 shall be used only as reference details for overall dimensions. Wing- walls shall be required for all the headwalls as indicated in Detail D-40.
3. General Surface Improvements: Detail G-36 will not be used.
 - a. Sprinkler Irrigation Systems
 - b. Traffic Control Plans
 - c. Sewerage Systems: Pending review from the PWD Utility Team.
 - d. Water Systems: Pending review from the PWD Utility Team.
 - e. The contractors shall delete the “County of San Diego” name when the standard details are used as part of the drawings and specifications.

STATE OF CALIFORNIA MANUAL OF TRAFFIC CONTROLS

1. Construction and Maintenance Work Zones

CALTRANS STANDARDS SPECIFICATIONS – MOST CURRENT EDITION

1. Grading Sections
2. Sub-bases and Bases Sections
3. Surfacing and Pavements Sections
4. Drainage Facilities Sections
5. Right of Way and Traffic Control Facilities Sections
6. Materials Sections
 - a. The Caltrans Standard Specifications are only applicable in their technical or engineering value, not in “measurements, and payment” related to the to specific agency requirements.
 - b. If conflict between these standard specifications and others requirements in the Camp Pendleton Requirements, the Camp Pendleton requirements prevail.

STANDARDS PLANS – STATE OF CALIFORNIA, DEPARTMENT OF TRANSPORTATION – MOST CURRENT EDITION

1. Pavement Markers, Traffic Lines and Pavement Markings: All Plans.
2. Excavation and Backfill: Miscellaneous Details, Concrete Pipe Culverts, Cast-In-Place Reinforced Concrete Box and Arch Culverts, and Metal/ Plastics Culverts.
3. Portable Concrete Barrier: All Plans.
4. Object Markers, Delineators, Channelizers and Barricades.
5. Concrete Barrier Type 60 Series: All Plans.
6. Metal Beam Guard Railing: Standard Railing Sections: All Plans
 - a. All Posts and Separators to be Typical Layout for Embankments
 - b. Typical Layout for Embankments
 - c. Typical Layout for Structures
 - d. Typical Layout for Fixed Objects
 - e. End Anchorage and Rail Tensioning Assembly
 - f. Connection Details and Transition Railing to Bridge Railings, Abutments and Wall
 - g. Terminal System End Treatment
 - h. All the posts and separators between the Beam Guard Railing and the Post to be galvanized steel to avoid damage during wild fires.
7. Three Beam Barrier: All Plans
 - a. Standard Barrier Sections
 - b. At Fixed Objects and on Bridge
 - c. End Anchorage, End Treatment and Emergency Passageway
 - d. Connections to Bridge Railings, Abutments, Walls and Barrier
 - e. Transition Railings
 - f. All the posts and separators between the Beam Guard Railing and the Post to be galvanized steel to avoid damage during wild fires.
8. Crash Cushions: All Plans
9. Steel Crib Walls: Construction Details, and Design Data
10. Drainage Inlets, Steel Pipe Inlets, Concrete Pipe Inlets, and Grates:
 - a. Drainage Inlets Details
 - b. Steel Pipe Inlets Details
 - c. Concrete Pipe Inlets – Ladder and Trash Rack Details
 - d. Grate Details
 - e. Bicycle Proof Grate Details
11. Concrete Pipe – Direct Design Method: All Plans
12. Box Culverts: All Plans. All Box Culverts shall include Wing Walls at Both Ends
13. Pipe and Arch Culvert – End Walls and Warped Wing Walls: All Plans
14. Pipe Down-drains, Anchorage Systems and Over-side Drains: All Plans
15. Construction Loads on Culverts and Strut Details: All Plans
16. Pipe Head Walls, End Walls, and Wing Walls - Pipe Culvert Head Walls, End Walls, and

- Wing Walls: Types A, B & C.
17. Flared End Sections – Metal and Plastic Flared End Sections
 18. Pipe Coupling and Joint Details: All Plans
 19. Slotted and Grated Line Drains: All Plans
 20. Retaining Walls: All Plans

POINT OF CONTACTS INFORMATION

Installation	Utilities	Point of Contacts (POC)
Government owned utilities are as follows:		
MCB Camp Pendleton	Water, Sewer, Electric, Gas, Steam, Facilities, Stormwater	Facilities Maintenance Department (760) 725-3139 or (760) 725-3558
MCB Camp Pendleton	Maintenance Systems, others not listed	Liaison Office (760)725-3638
Telecommunications, Phones, Energy, GIS and Security are as follows:		
MCB Camp Pendleton	Base Comm. Info System	(760) 725-6222 or (760) 763-5628
MCB Camp Pendleton	Base Energy Management	(760) 725-0567 or (760) 725-0566
MCB Camp Pendleton	GIS Support	(760) 763-1891 or (760) 725-6281
MCB Camp Pendleton	Security	(760) 725-0819 or (760) 725-0818
Private utility companies that the A-E shall coordinate are as follows:		
	Gas and Electric	San Diego Gas & Electric
	Petroleum Product	Southern Counties Gas
	Cable TV	Cox Cablevision
	Telephone	Pacific Bell

BEAP ADDENDA

- **CHAPTER 3.5** **ARCHITECTURAL REQUIREMENTS**
- **CHAPTER 3.5C2** **USE OF SKYLIGHTS VS. CLERESTORY WINDOWS**
- **CHAPTER 3.5C** **WINDOW SET BACKS**
- **CHAPTER 3.5C3e** **BIRD DETERRENT**
- **CHAPTER 3.5C4e** **BUILDING APPURTENANCES**
- **CHAPTER 3.6D** **LANDSCAPE GUIDELINES**
- **CHAPTER 3.6H8** **EROSION CONTROL**
- **CHAPTER 3.10** **SIGNAGE (GENERAL & ANCILLARY STRUCTURES)**
- **CHAPTER 3.10D1b** **SECONDARY ENTRY GATE SIGNS**
- **CHAPTER 3.10D2** **CANTONMENT IDENTIFICATION ENTRY SIGNS**
- **CHAPTER 3.16** **TRASH ENCLOSURES-TRASH & RECYCLING CONTAINERS**
- **CHAPTER 3.17** **ABOVE GROUND STORAGE TANK**
- **CHAPTER 8.2A5** **EXTERIOR FOUNDATION DETAIL**
- **CHAPTER 8.9** **BUILT-IN BBQ UNITS**
- **CHAPTER 8.9E5** **HOT CHARCOAL CONTAINER**
- **CHAPTER 8.9I5/16** **BOLLARD**
- **CHAPTER 12D8** **FLAGPOLE**
- **CHAPTER 11.2** **SUBMITTAL MATRIX**
- **APPENDIX A BASEWIDE COLOR AND APPENDIX B COLOR BOARD LAYOUT**

CHAPTER 3.5

ARCHITECTURAL REQUIREMENTS

GENERAL

1. Provide details for transition conditions from existing to new construction components (pavement, roof, pipe, walls, etc).

PLUMBING

1. Water use is designed to 100% occupancy load.
2. Flush valves on toilets and urinals, and faucets at lavatories to be manually operated. Toilet valves can be dual flush and lavatory faucets can be self metering for water conservation.

PLUMBING and COMMUNICATIONS

1. All conduits and pipes should be properly capped at all vaults, hand holes, and junction areas. (Note: There have been repeated problems with conduits abandoned in place that were not properly cap or plugged resulting in rooms flooding).

DOORS and HARDWARE

1. All steel doors shall be Level 3, Extra heavy duty, seamless construction, flush top and vertical stiffeners as defined in the Steel Door Institute manual. The doors and frames shall have reinforced backing for closers, strikes, hinges, locks and latch-sets.
2. All architectural door hardware shall be grade 1 heavy duty as defined in the American National Standards Institute, Inc. (ANSI) and the Builders Hardware Manufacturers Association, Inc. (BHMA).
3. For all Camp Pendleton BEQ's, door hardware shall be the "vertical-swipe" feature Electro-Magnetic (Smart Card or Electronic Card) Programmable Locks, (Kaba Solataire locks- or approved equal) Matching, existing card key system for Camp Pendleton, *is preferred*. Provide card key type access units for *BEQs and* specialized entries as required by the program. Provide alkaline battery powered, magnetic stripe keycard locksets that are ANSI/BHMA A156.13, Series 1000, Grade 1, mortise sets....tamper resistant, UL listed with 25 mm (1 inch) throw deadbolt, 19 mm (3/4 inch) backset.
4. (submit hardware specifications) for approval by Public Works and ROICC prior to purchase and installation.
5. The latch bolt and dead bolt shall be operated simultaneously by rotating inside knob, except at ADA Room lever.
Locks shall be operated only by a correctly encoded cardkey. Use of a newly issued keycard automatically rekeys the lock and voids the previous keycard. Locks shall have memory that is capable of recording up to **140 entries** into each room, identification of the keycard used to access the room, the date and time of entry.
6. System shall be capable of accepting a minimum of **12 keycard** access levels, security auditing and computer interfacing with the existing or new management systems. On-site service shall be provided within **3 hours** from request within the first **12 months** of occupancy.

7. Provide a **5-year** parts and labor warranty.

MASONRY BLOCK

1. *CMU precision block shall be used at all soffit and wall connections.*
2. *Termite control in the soil or under the slab in new construction is not necessary for buildings constructed with CMU.*

SHADE STRUCTURES

1. *The color of the underside of the roof should be white.*
2. *Following the BEAP:*
 - a. *The length of the roof overhang should be a minimum of 1' with a minimum 8" fascia.*
 - b. *Provide gutters and downspouts.*
 - c. *The roof pitch is 4:12 or minimum 3:12 to match adjacent building roof pitch.*
3. *The caps on the top of the CMU columns should be 18"x18" concrete precast, or approved by Public Works.*
4. *The CMU columns should be 16"x16".*
5. *The color of the structural members should be per DOR to match adjacent buildings.*

ROOFING AND EAVES

1. *PVC, TPO, EPDM, or any single ply roofing materials have a scrim that acts as a reinforcement to the product. A product that claims to have 60 mil. thickness shall have a minimum coverage over the scrim of at least 28 mil.*
2. *PVC roof materials shall be free of stress cracks and tears, prior to and post-installation.*
3. *All single ply, should have a probe test completed by the manufacturer prior to turnover. for all single ply, not just PVC.*
4. *All roof- skylights shall be mounted on a curb at least 4" above roof plane.*
5. *Roofing transition shall be secured with positive drainage and material.*
6. *Standing Seam Metal Roofing (SSMR): Provide details for eaves, ridges, hips and gutters with closure.*
7. *Provide overflow drains with inlet details to scupper on low pitch new or renovation roof work.*
8. *Rigid insulation is required on roofs unless approved otherwise by Public Works.*
9. *Hi-Temp UV resistant Self Adhesive membranes are required at all ridges, valleys, and shall be extended to a minimum distance of 18" each side of the ridge or valley line. Underlayment is required. All penetrations such as skylights or tubes, and curbs shall be fully covered and sealed with self adhesive membrane. Crickets are required at all skylights or tubes, curbs and conditions where roofs slope toward walls. Counter flashing is required at all points where the roof transitions to a wall; all such conditions require*

counter flashing. Counter flashing is required to be let into the CMU and fully sealed. Flashed diversion channels are required when water drains to the back side of a wall to slow the flow of water and redirect to a valley. NRCA compliance is required, but does not limit the requirements within this section.

10. Sealants shall be silicone and color matched to be approved by Public Works.
11. The best warranty available in the industry to be provided for each roofing type.

SEALANTS FOR STANDING SEAM ROOFS

Where standing seam metal roofing is cut, and forms a junction with other roof members (louvers, etc.), the following issues must be addressed:

1. Sealant, or caulking is never a substitute for proper flashing detailing.
2. All sealants should be UV reflective to a standard level comparable to the roof surface on which they are being used.
3. Where a manufacturer's recommended application of a sealant calls for two coats, two coats must be applied.
4. Acceptable sealant types are TREMCO Tremprime Silicone Metal Sealer, or approved equal. The following sealants are not recommended, but may be acceptable, only if a minimum of two coats of application can be verified: Tremprime non-porous Primer, Vulkem Primer #171, Tremprime Multi-surface Urethane Primer, Vulkem Primer #191, Vulkem Primer #191 Low-VOC.
5. No attic or interior system supports (suspended ceiling grids, piping supports, etc.) should ever have their fasteners drilled through the standing seam metal roofing. Care must be exercised to make sure that any drilling is done through the bottom flutes of a roof deck; and that the screws used to fasten are not longer than the dimension from the bottom to top flutes of the deck. Any penetration of these fasteners through the standing seam roof surface is unacceptable.

METAL ARCHITECTURAL ELEMENTS (AWNINGS, SHADE STRUCTURES ETC.)

1. Prior to the powder coating, the galvanized steel must have an appropriate SSPC-SPG sweep blast to etch the Galv.
2. Prebake items in oven at 410 F, apply outgas forgiving epoxy primer.
3. Apply a "Super Durable" polyester top-coat finish in the approved color.

WINDOW BLINDS/SHADES

1. All roll down blinds/shades shall not make contact with any part of the window hardware when the blind/shade is lowered or raised.
2. Solar shading roll down screens are preferred over mini-blinds.

SHOWER

1. *All glass shower doors are prohibited. Plastic shower doors are acceptable.*
2. *Shower valves to be non institutional thermostatic type.*
3. *Shower head shall be of the swivel type with an adjustable spray pattern and FIP threaded connection into a MIP threaded shower arm.*
4. *Shower curtain shall drop to 1-1/2 inches below the shower dam top edge.*
5. *Towel racks shall not be placed in any location where they come in contact with the opening of bathroom or toilet room doors.*
6. *Direction of shower head flow should not be out of the shower.*
7. *Control lever should not be on back inside wall, rather on side so the water temperature can be regulated without entry.*

LAUNDRY

1. *All washer machine laundry trays shall have only a drain pipe outlet hole and two inlet holes for the hot & cold water supply pipes. The tray shall be constructed of plastic non-corroding material. All metal laundry trays shall be prohibited.*
2. *Attach numbering labels to all laundry washers and dryers. Provide numbers next to circuit breakers that coordinate w/numbers on washers and dryers.*
3. *If the project square footage allows, it is preferred that heavy duty commercial grade washers and dryers be provided.*
4. *Laundry room s.f. and quantities of units to comply with current HQMC standard.*
5. *Dryer Vent Duct:*
 - a. *Should not be longer than 25' straight run.*
 - b. *A run with up to a 45 degree bend should not be longer than 22.5'*
 - c. *A run with a bend 45 degree to 90 degree should not be longer than 20'*
 - d. *Dryer vent shall not be routed to public walkways.*
6. *Per IMC 504, clothes dryer transition ducts attached to the backs of the dryers to be rigid metal or at a minimum 0.4mm thick flexible metal. Transition ducts of flexible foil or plastics is not allowed (these are combustibile and not safe or durable).*

ATTIC

1. *Access Hatch to the roof surface is not desired until UFC 3-600-01, 2-9 Roof Access is changed.*
2. *All attic spaces shall have adequate maintenance access from within the building.*
3. *Attic spaces to be insulated to allow temperature to remain less than 10 degrees Fahrenheit over exterior ambient temperature.*
4. *All attic areas must be ventilated naturally.*

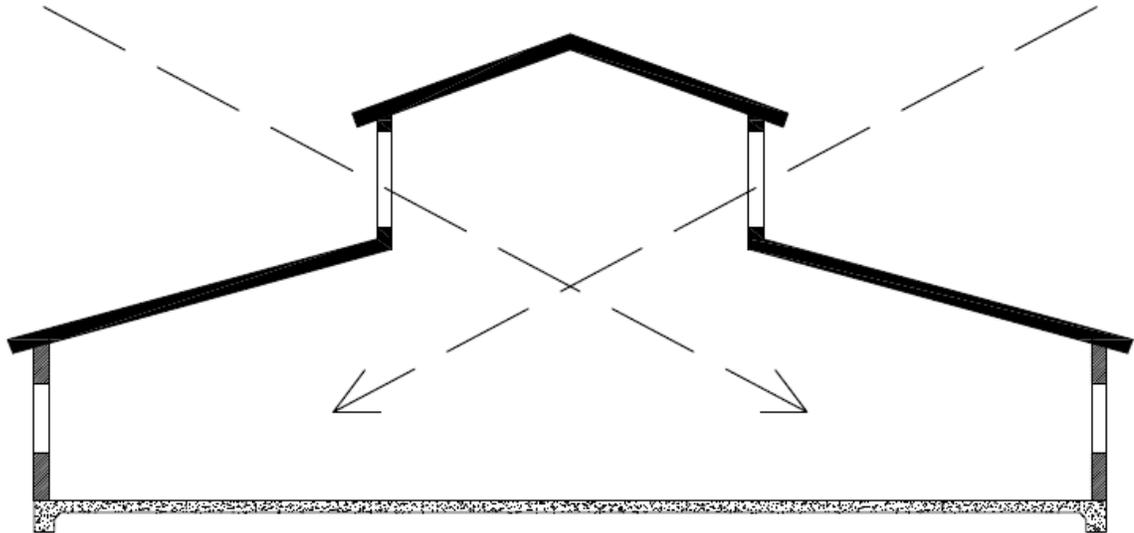
LIGHTNING PROTECTION

1. *Camp Pendleton is not in a weather zone that gets a significant amount of lightning (such as the Midwest, East Coast or Southern States). Lightning protection is not necessary or desired unless:*
 - a. *The building or structure is a tower and is fabricated out of metal (such as a paraloft).*
 - b. *The building or structure houses or stores hazardous materials or explosives.*

CHAPTER 3.5C2

USE OF SKYLIGHTS VS. CLERESTORY WINDOWS

The use of multiple skylights, or sunlight-reflective tube style roof openings, in new or renovation construction of long span buildings is discouraged. Multiple roof penetrations are not desired due to the increased risk of roof leakage. The preferred method of achieving interior day lighting is through the design and usage of clerestory windows when standard height windows do not provide adequate daylighting to interior spaces due to building size, configuration, etc. This simple change should be incorporated early in the process for new roof construction design.



See the attached sketch.

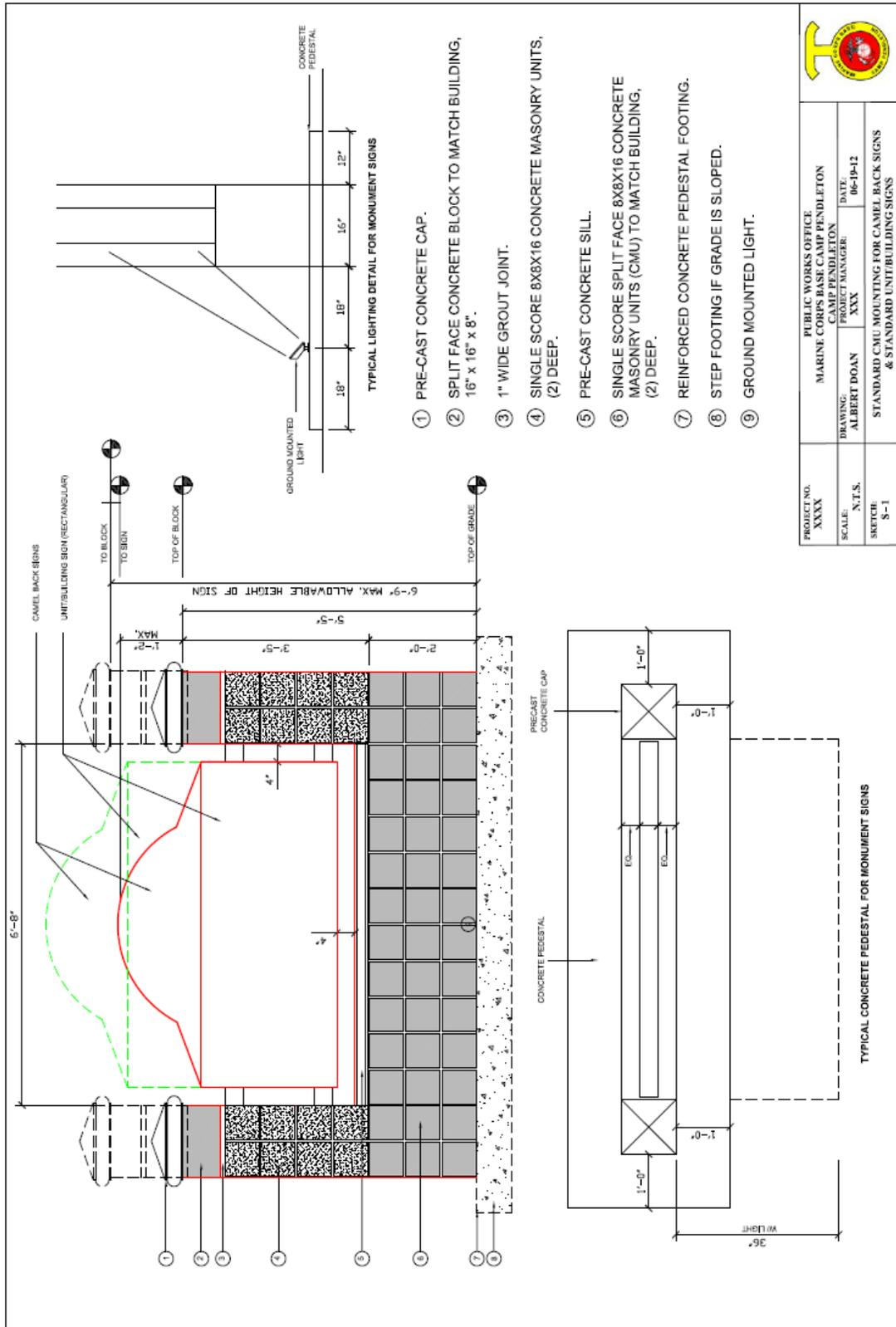
SIMPLE CLERESTORY WINDOWS IN LONG SPAN BUILDINGS ALLOW LIGHT TO PENETRATE DEEP INTO THE SPACES

CHAPTER 3.5C

FIGURE 3.5-11

1. *Provide kerf cut set back 1" from the face of exterior CMU header and precast sill. Kerf to be min 1/4" deep.*
2. *Window frame to be set back 2"- 4" from the face of exterior CMU.*

**CHAPTER 3.10 SIGNAGE
BUILDING MONUMENT SIGN**



PROJECT NO. XXXX	PUBLIC WORKS OFFICE MARINE CORPS BASE CAMP PENDLETON	
SCALE: N.T.S.	DRAWING ALBERT DOAN	PROJECT MANAGER XXX
SKETCH S-1	DATE 06-19-12	
STANDARD CMU MOUNTING FOR CAMEL BACK SIGNS & STANDARD UNIT/BUILDING SIGNS		

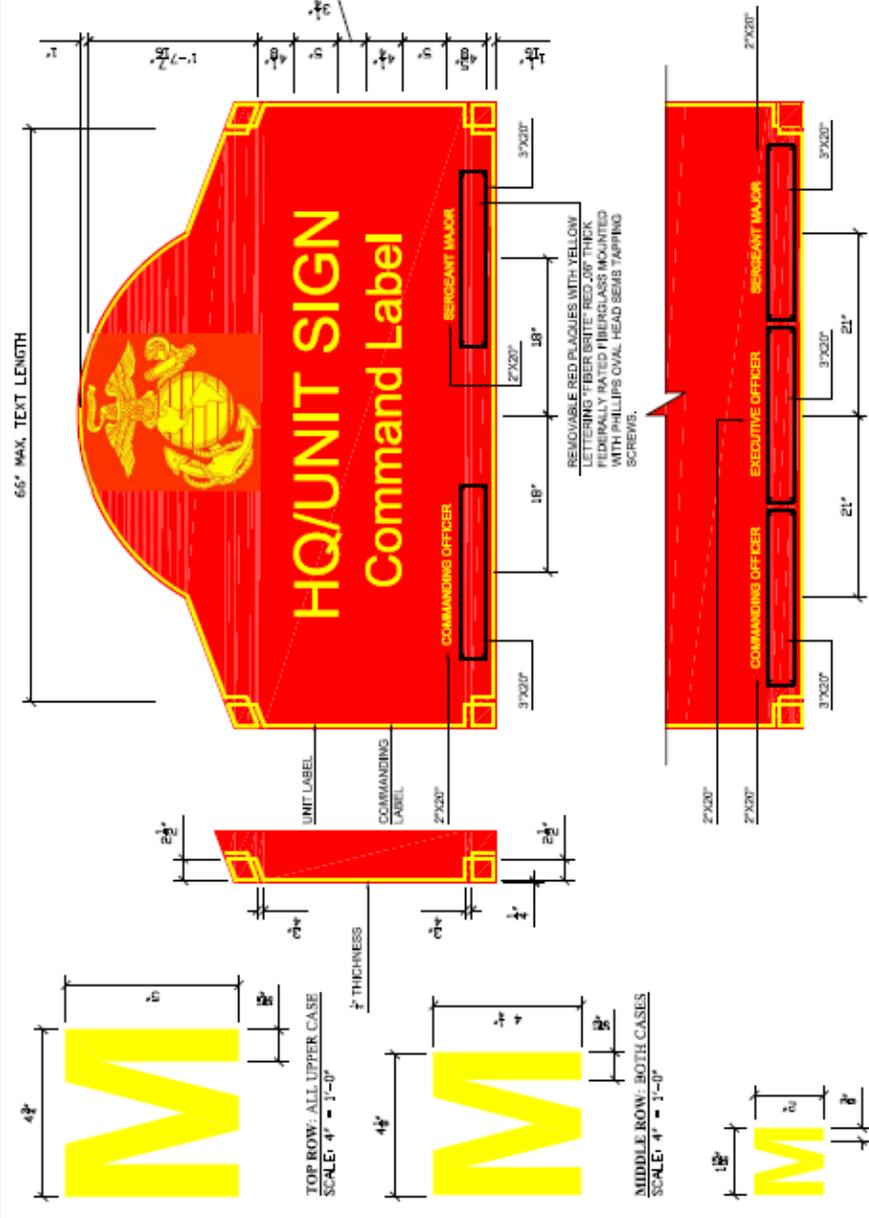


HQ/UNIT MONUMENT SIGN STANDARDS:

1. THIS TYPE OF SIGN RESERVED FOR BATTALION AND ABOVE.
2. EGA 18" WILL VARY DEPENDING ON AMOUNT OF TEXT.
3. LETTERING SIZES VARY FROM APPROX. 2" HIGH TO 5" HIGH DEPENDING ON AMOUNT OF TEXT.
4. CAMEL BACK SIGNS TO BE IN CIMU MONUMENT.
5. TYPICAL SIGN MOUNTING PER MCB CAMP PENDLETON BEAP DETAIL 8.7 A-7 (GALVANIZED METAL BRACKET) & DETAIL 8.7 A-10.
6. THE SIGN FACE TO BE CONSTRUCTED WITH A 0.125 (1/8") THICK ALUMINUM BASE.
7. PROVIDE SIGNAGE GRAPHICS ON BOTH SIDES OF SIGN
8. ALL SIGNS/LOCATIONS TO BE APPROVED BY CP SIGN SHOP BEFORE FABRICATION/INSTALLATION.
9. HQ AND UNIT MONUMENT SIGNS
THE SIGN FACE IS RED WITH YELLOW LETTERS.
RED SIGN FACE:
MANUFAC: ARLON VINYL FILM
TYPE : PRESSURE SENSITIVE VINYL
GRADE : ENGINEER GRADE
SERIES : 2400-2450 REFLECTA-CAL
COLOR : 01 RED
YELLOW LETTERING: BORDER AND EGA
MANUFAC: ARLON VINYL FILM
TYPE : PRESSURE SENSITIVE VINYL
SERIES : 2100 HIGH PERFORMANCE
COLOR : 008 YELLOW
FRONT: HELVETICA BOLD
LETTERING: ALL LETTERING TO BE CENTERED ON SIGN

THE SIGN FACE IS BLUE WITH WHITE LETTERS.
BLUE SIGN FACE:
MANUFAC: ARLON VINYL FILM
TYPE : PRESSURE SENSITIVE VINYL
GRADE : ENGINEER GRADE
SERIES : 2400-2450 REFLECTA-CAL
COLOR : 05 BLUE
WHITE LETTERING:
MANUFAC: ARLON VINYL FILM
TYPE : PRESSURE SENSITIVE VINYL
SERIES : 2100 HIGH PERFORMANCE
COLOR : 002 WHITE
FONT : HELVETICA BOLD
LETTERING : ALL LETTERING TO BE CENTERED ON SIGN

9. MEDICAL/DENTAL MONUMENT SIGNS
THE SIGN FACE IS BLUE WITH WHITE LETTERS.
BLUE SIGN FACE:
MANUFAC: ARLON VINYL FILM
TYPE : PRESSURE SENSITIVE VINYL
GRADE : ENGINEER GRADE
SERIES : 2400-2450 REFLECTA-CAL
COLOR : 05 BLUE
WHITE LETTERING:
MANUFAC: ARLON VINYL FILM
TYPE : PRESSURE SENSITIVE VINYL
SERIES : 2100 HIGH PERFORMANCE
COLOR : 002 WHITE
FONT : HELVETICA BOLD
LETTERING : ALL LETTERING TO BE CENTERED ON SIGN



PROJECT NO. XXXX	PUBLIC WORKS OFFICE MARINE CORPS BASE CAMP PENDLETON
SCALE: 1" = 1'-0"	PREPARED BY: ALBERT DOAN
SKETCH: S-2	DATE: 04-20-12
STANDARD LETTERING FOR HQ/ UNIT MONUMENT SIGN	

**STANDARD LETTERING FOR HQ/ UNIT
MONUMENT SIGN**
SCALE: 4" = 1'-0"

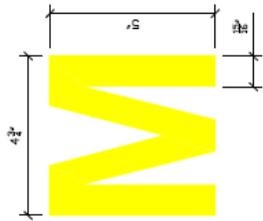
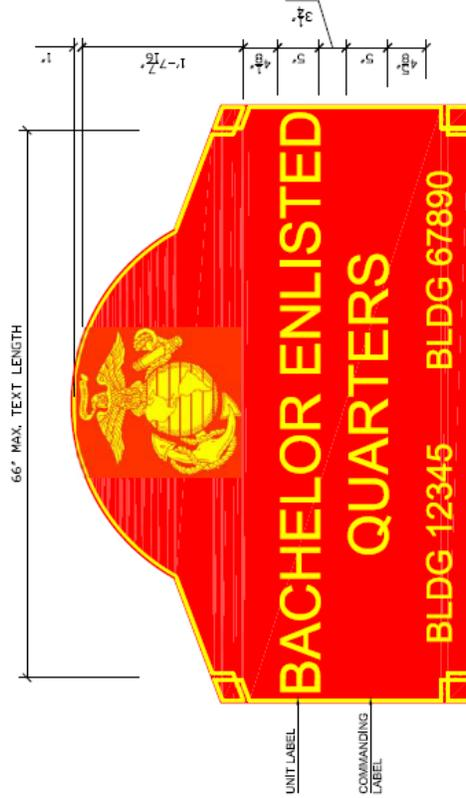
BEQ SIGN STANDARDS:

1. EGA 18" WILL VARY DEPENDING ON AMOUNT OF TEXT.
2. LETTERING SIZES VARY FROM APPROX. 2" HIGH TO 5" HIGH DEPENDING ON AMOUNT OF TEXT.
3. CAMEL BACK SIGNS TO BE IN CMU MONUMENT.
4. TYPICAL SIGN MOUNTING PER MCB CAMP PENDLETON BEAP DETAIL 6.7 A-7 (GALVANIZED METAL OR ALUMINUM BRACKETS) & DETAIL 6.7 A-10.
5. FOR BEQs IN A CAMPUS SETTING, LOCATE SIGN AT STREET AT POINTS OF ENTRY TO THE CAMPUS. INCLUDE THE BLDG NUMBERS OF BEQ BLDGS IN PROXIMITY TO THAT ENTRY POINT.
6. PROVIDE SIGNAGE GRAPHICS ON BOTH SIDES OF SIGN.
7. ALL SIGNS/ LOCATIONS TO BE APPROVED BY CP SIGN SHOP BEFORE FABRICATION/ INSTALLATION.
8. THE SIGN TO BE 0.125 (1/8") THICK ALUMINUM.
9. BEQ MONUMENT SIGNS
THE SIGN FACE IS RED WITH YELLOW LETTERS.

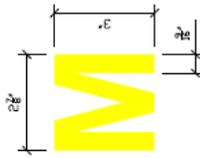
RED SIGN FACE:
 MANUFAC: ARLON VINYL FILM
 TYPE : PRESSURE SENSITIVE VINYL
 GRADE : ENGINEER GRADE
 SERIES : 2400-2450 REFLECTA-CAL
 COLOR : 01 RED

YELLOW LETTERING: BORDER AND EGA
 MANUFAC: ARLON VINYL FILM
 TYPE : PRESSURE SENSITIVE VINYL
 SERIES : 2100 HIGH PERFORMANCE
 COLOR : 008 YELLOW

FONT : HELVETICA BOLD
 LETTERING : ALL LETTERING TO BE CENTERED ON SIGN



TOP ROW: ALL UPPER CASE
 SCALE: 4" = 1'-0"



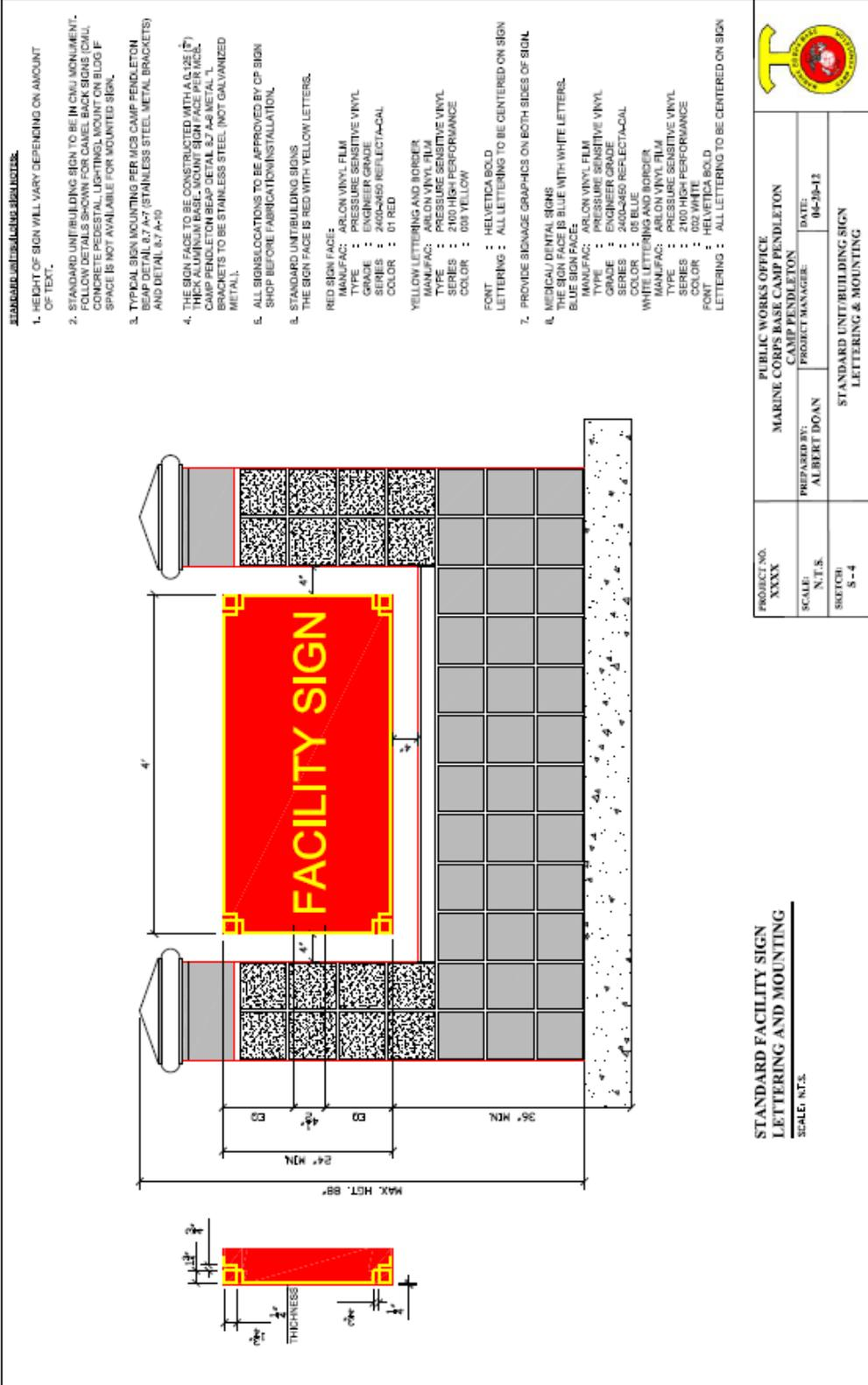
LOWER ROW: ALL UPPER CASE
 SCALE: 4" = 1'-0"

STANDARD LETTERING FOR BEQ MONUMENT SIGN

SCALE: 1" = 1'-0"

PROJECT NO. XXXX	PUBLIC WORKS OFFICE MARINE CORPS BASE CAMP PENDLETON CAMP PENDLETON
SCALE: 1" = 1'-0"	PREPARED BY: ALBERT DOAN
SKETCH: S-3	DATE: 04-20-12
STANDARD LETTERING FOR BEQ MONUMENT SIGN	





NUMBER IDENTIFICATION SIGNS of ANCILLARY STRUCTURES

1. Ancillary Structures include but are not limited to:
 - a. Trash Enclosures
 - b. Utility Boxes
 - c. Bleachers/Viewing Stands
 - d. Basketball Courts
 - e. Bus Shelters
 - f. Training Towers
 - g. Valve covers, Manholes, etc.

GENERAL:

1. A number identification sign is desired for each ancillary structure, however, if there is more than one access point (i.e. a trash enclosure that could be approached by trash trucks or emergency vehicles from opposite sides or a bus shelter that is approached from opposite sides), then two or more sets of numbers may be required.
2. All signs and their locations to be approved by Camp Pendleton Sign Shop before fabrication and/or installation.
3. Construction Manager to obtain ancillary structure numbers from Real Property Accounting Lead located in Building 220102T at 760-763-7832
4. Number Font: Helvetica Bold
5. Sign Material Specifications:

VINYL LETTERS:

1. Type: Pressure Sensitive Vinyl
Series: 2100 High Performance
Color: 006 Yellow, 002 White, 003 Black

Sign Backing:

1. Type: Federally Rated Fiberglass
Thickness: .06"
Color: *White for all Marine Corps structures and blue for all NAVFAC structures*

Individual Metal Numbers:

1. Type: Bronze Anodized Aluminum
Size: 6" high
Ref: MCB Camp Pendleton BEAP 26 July 2010
*Building ID Signage for multi-story shall typically be mounted at the second floor deck level, and be illuminated per BEAP section 3.10011.
Mounting the light fixture below the numbers, to up light them, is preferred.*

UTILITY BOXES

Locate identification number signs on the upper right hand corner on the front of the utility box. The number identification sign will be individual 3" yellow vinyl numbers.



Photo 1: Utility Box

BUS SHELTERS

Number identification signs to be mounted on ends of bus shelter so that signs are easily visible from traffic approaching from both sides. The number identification sign will be individual 3" white vinyl numbers. (Photo 2)



Photo 2: Bus Shelter

TRASH ENCLOSURES:

Locate identification number signs on the upper corner of an outside wall closest to the accessible side of the enclosure. The sign will be 6" black vinyl numbers on an 8" x 24" white fiberglass backing. The sign will be mounted onto the block wall of the trash enclosure with anchoring screws (Photo 3). Do not locate signs inside the trash enclosure (photo 4).



Photo 3: Correct Sign Placement for Trash Enclosure



Photo 4: Incorrect Sign Placement for Trash Enclosure

BASKETBALL COURTS

Number Identification Signs to be mounted on both ends of the fence near the basketball backboard/poles. The signs will be 6" black vinyl numbers on an 8" x 24" white fiberglass backing. The signs to be mounted on the fence with vandal proof hardware. (Photo 5).

If a fence is not available, the number identification sign is to be mounted vertically on the poles of the backstop with bottom of last number at 7'-0" high. The number identification sign will be individual 3" white vinyl numbers (Photo 6).



Photo 5: Sign on Fence of Basketball Court



Photo 6: Sign on pole of backstop (numbers in photo are not properly mounted at 7' high)

RANGE STRUCTURES

Open Air Structures: Number Identification Signs to be mounted vertically on support poles or on an easily accessible overhang. The number identification sign will be individual 3" white vinyl numbers (Photo 7).

Concrete Block Structures: The sign will be 6" black vinyl numbers on an 8" x 24" white fiberglass backing. The sign will be mounted onto the block wall of the structure with anchoring screws (Photo 8).



Photo 7: Range Open Air Structure

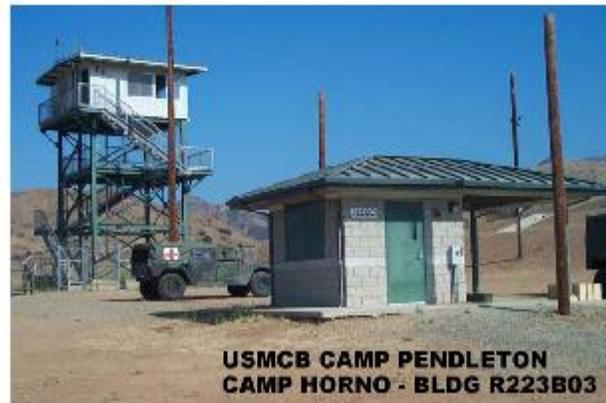


Photo 8: Range Concrete Block Structure

BLEACHERS/VIEWING STANDS

Number identification signs to be mounted vertically on support poles (individual 3" white vinyl numbers) or on an easily accessible overhang (6" black vinyl numbers on an 8" x 24" white fiberglass backing). (Photos 9 and 10)



Photo 9: Sign on road accessible side of bleachers



Photo 10: Sign on overhang

TOWERS

The sign will be 6" black vinyl numbers on an 8" x 24" white fiberglass backing. The sign will be mounted on to the structure with anchoring screws (Photo 11).

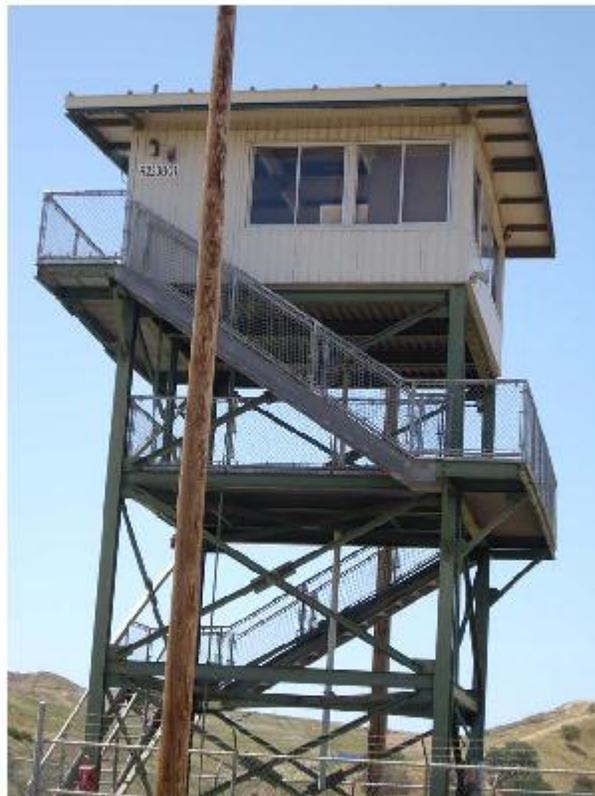


Photo 11: Sign on accessible side of tower

BEQ SHADE STRUCTURE

Locate Number Identification Sign on an easily accessible side of the structure. Sign to be made up of 6" high individual bronze anodized aluminum characters in Helvetica Bold font per the MCB Camp Pendleton BEAP. Numbers to be in contrast with background (photo12)



Photo 12: Number Identification Sign on BEQ shade structure

NAVFAC ANCILLARY STRUCTURES

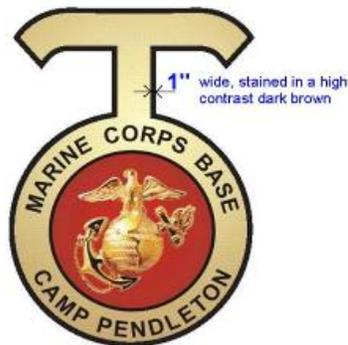
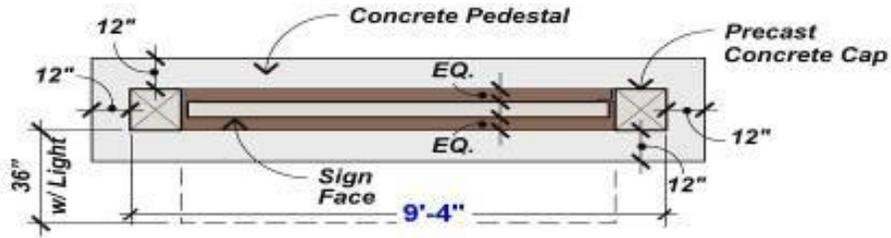
Locate identification number signs on the upper corner of an outside wall. The sign will be 6" white vinyl numbers on an 8" x 24" blue fiberglass backing. The sign will be mounted onto the structure with anchoring screws. (Photo 13)



Photo 13: NAVFAC Ancillary Structure

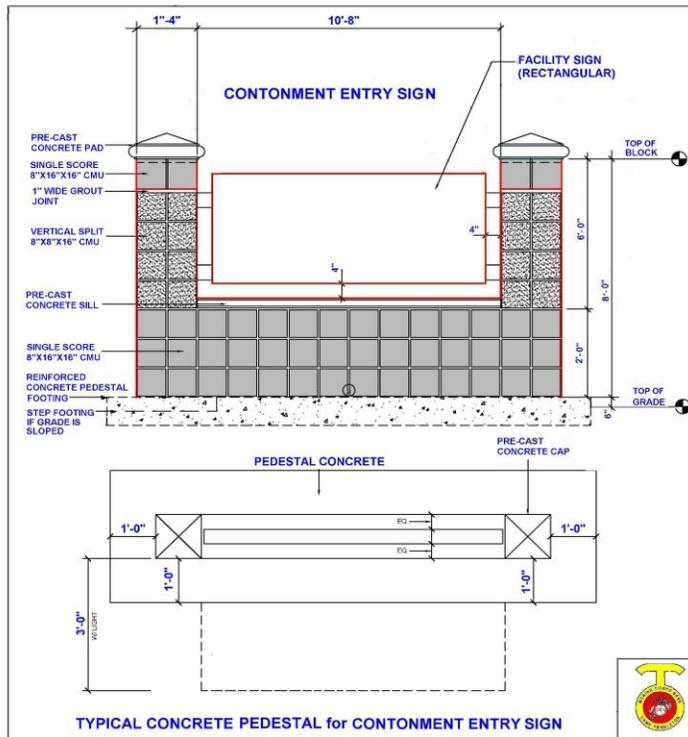
CHAPTER 3.10D1b SECONDARY ENTRY GATE SIGNS

Precast concrete cap 16"x16" (min.)



CHAPTER 3.10D2 CANTONMENT IDENTIFICATION ENTRY SIGNS

Construct a 2x6 inch “tongue and groove” wood material sign face with a **solid or opaque stain** background and yellow letters.



CHAPTER 3.16 TRASH ENCLOSURES-TRASH & RECYCLING CONTAINERS

These standards provide information and resources for designing solid waste (non-hazardous) and recycling enclosures that will be used by building occupants. The coordinated design of trash enclosures will enhance the function and appearances of the base exterior, reinforce the design theme, reduce maintenance requirements, and support solid waste and recycling regulations and directives at Camp Pendleton.

3.16 A. OBSERVATIONS

There is variation in the design, layout, detail and recycling capabilities of trash enclosures at Camp Pendleton. The general observations include:

- There is little or no design coordination between existing trash enclosures and no overall uniformity in the design and layout of trash enclosures.
- Trash enclosures must meet AT/FP requirements, display similar materials as approved for on-base use, be durable, and require minimal maintenance (Figure 3.16-1).



Figure 3.16-1: Trash enclosure in the Del Mar (21) Area.



Figure 3.16-2: Unenclosed dumpsters located in the parking lot at Chappo (22) Area.

3.16 B. TRASH ENCLOSURE OBJECTIVES

The goal for trash enclosure design is to create a uniform design supportive of the overall base design theme and related to each other by compatibility of material, color, form and design detail. The location of trash enclosures has a significant visual impact and must be addressed as part of an overall building design and incorporated in site planning.

3.16 C. Trash Enclosure Guidelines

1. Location and Materials

- a. Locate trash enclosures to be inconspicuous such that their presence does not detract from the overall design focus and layout of the surrounding area (Figures 3.16-2 and 3.16-3).
- b. Avoid locating trash enclosures along major circulation or use areas (Figure 3.16-3). Trash enclosures are to be directly accessible by way of a paved service drive or parking lot with adequate overhead clearance for collection vehicles (Figure 3.16-4).



Figure 3.16-3: Unenclosed dumpsters in Edson Range located along main road through cantonment.



Figure 3.16-4: Enclosure wall around dumpsters along a Service road.

- c. Driveways or aisles shall provide unobstructed access for collection vehicles and personnel and provide at least the minimum clearance required by the collection methods and vehicles utilized by the designated collector.
- d. Provide vertical clearance above trash enclosures free of overhead obstructions as required by the collection methods and vehicles utilized by the designated collector.
- e. Consider the location and orientation of trash enclosures as related to AT/FP requirements and the design of its surrounding environment. AT/FP requirements restrict the location of dumpsters to outside the designated unobstructed space from inhabited buildings, billeting and primary gathering areas. In addition, they should face away from structures.
- f. Refer to current UFC 4-010-01, Design: DoD Minimum Antiterrorism Standards for Buildings, for Standoff Distances.

2. Access

All enclosures are required to have direct access for *front loading* collection trucks. Direct access means the collection truck can drive directly up to the bin, and insert the forks into the sides of the bin without the driver having to get out of the truck to move the bin (Figure 3.16-4).

- a. Vehicular path of travel shall have minimal conflict with on-site vehicle and pedestrian circulation patterns.
- b. Driveways and drive aisles leading to enclosures shall be minimum 18 feet wide.
- c. Provide sufficient area for front-end loader collection truck turning radius.
- d. Provide a minimum 50 foot straight approach for access to stationary (no wheels) bins.
- e. Design trash enclosure so each bin can be removed and replaced without having to take out other bins, to avoid stacking, and to maximize access.
- f. For each trash enclosure containing three bins, two bins shall be designated for solid waste (nonhazardous), and one bin shall be for recycling (Figure 3.16-5). At the enclosure opening, the solid waste bins shall be on the left side, and the recycling bin shall be on the right side.
- g. If wheeling (i.e., manually pushing) bins from enclosure to a truck collection area is anticipated, provide minimum ten foot wide concrete pathway with slope less than two percent.



Figure 3.16-5: Solid waste and recycling bins shall be placed within an enclosure.



Figure 3.16-6: Wooden rails are not allowed within an enclosure.

3. Trash Enclosure Design

- a. Enclosures shall be built to accommodate three trash bins. See Detail 8.9 L-2.
- b. Incorporate plantings to buffer the visual impact of screen walls. Provide a minimum three foot clearance on each side between screen walls and dumpsters to allow adequate pedestrian and truck access.
- c. Storm water shall be prevented from running into the enclosure. There shall be no storm drain or wastewater connections within the enclosure.
- d. Trash storage areas shall be paved with an impervious concrete surface.
- e. All dumpsters are to be placed on concrete pads with aprons large enough to encompass the bearing points of the service vehicle.
- f. Construct enclosure walls from concrete masonry units. Color should match nearby buildings and screen walls.
- g. Construct a concrete apron extending 10 feet from the enclosure pad the width of the enclosure opening. The enclosure base shall be six inches of concrete over two inches of aggregate base rock. The builder shall provide evidence that construction specs are engineered to withstand up to 20,000 pounds of direct force from a single truck axle.
- h. Wooden rails (Figure 3.16-6) or bollards are not permitted within the enclosure. Instead, an eight inch wide by six inch high concrete curb (at inside perimeter of walls) shall be installed to prevent bins from touching the back and side walls.
- i. The enclosure will not have gates.
- j. 3' high steel bollards shall be installed to protect impacts to each wing wall of the enclosure.

TRASH and RECYCLING CONTAINERS

- Each new building constructed on the Base shall have a CMU enclosure with trash and recycling containers. Comply with the Base Exterior Architecture Plan (BEAP) for enclosure requirements. Trash and recycling containers to be included in the construction budget and purchased and installed by the General Contractor. Size and quantity to be determined during initial design phase of project.

2. TRASH CONTAINER

SIZE	*A	B	C	D	E
6 YD	72"	66"	50"	69"	41.5"

*Add 4" per side (A) for sleeve width

3. 6 YD HUMPBACK w/ 12 GA BOTTOM

SERIAL #: 357736 – 357831
 GSA SCHEDULE: #GS-07F-5512P
 MFG PART #40-9007
 COLOR: Marine Corp Green
 LABEL: Stencil per special instructions
 (Contact: Camp Pendleton Recycling Center Mgr. 760-725-4982)

**4. SPLIT RECYCLING CONTAINER
 (Split: ½ cans/bottles and ½ paper/cardboard)**

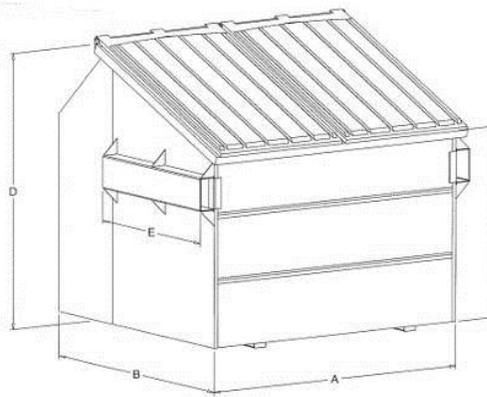
SIZE	FRONT HEIGHT	BACK HEIGHT	WIDTH	LENGTH
	C**	D**	B	*A
4 YD	46"	57"	50.5"	72"

*Add 4" per side (A) for sleeve width

**Casters add 8" to height

5. 9107-1 4 YD PITCH TOP SPLIT UNIT w/ 12 GA BOTTOM

SERIAL #: 327467 - 327487
 GSA SCHEDULE: #GS-07F-5512P (Some options are not on GSA)
 MFG PART #40-9007
 COLOR: ½ White and ½ Blue
 LABEL: Stencil Per Special Instructions
 (Contact: Camp Pendleton Recycling Center Mgr. 760-725-4982)



CHAPTER 3.17 ABOVE GROUND STORAGE TANK

Above Ground Storage Tanks (AST's) are commonly used to store gasoline, diesel fuel, oils, lubricants, and other liquids. AST's refer to both permanent, fixed tanks, as well as portable containers 55 gallons or greater in size. Above Ground Storage Tanks (AST) often have a blighting impact on Base appearance. AST's will benefit from more complete screening than is offered by chain link fence. The coordinated design of AST screened enclosures will enhance the function, appearance of the base exterior, and reinforce the design theme.

3.17 A. Observations

There is a great diversity in the size, configuration, detail, and screening methods of AST's at Camp Pendleton. The general observations include:

- a. There is no overall uniformity in the design of screening AST enclosures (Figures 3.17-1 to 3).
- b. AST screening should display similar materials as approved for on-base use, be durable, and require minimal maintenance.



Figure 3.17-1: Typical AST.



Figure 3.17-2: Bollards surrounding AST in Talega (64) Area.

3.17 B. Objectives

The goal for AST screening enclosure design is to create a uniform design supportive of the overall base design theme and related to each other by compatibility of material, color, form and design detail. Objectives are as follows:

- a. Screen unsightly AST's from view.
- b. Standardize screening elements. The design of all AST screened enclosures should achieve unity of appearance through repetitive use of colors, materials and common details.

- c. Visual disorder will be further alleviated by the use of standard screening elements and details.
- d. All screen material should be durable and low maintenance. High quality temporary screens should also be capable of being easily removed and relocated.
- e. Carefully consider the location of AST's as related to AT/FP criteria and the appearance and design of its surrounding environment. AST's shall not be located within required AT/FP standoff distances.
- f. In new project areas, identify locations where screening is needed and describe conditions and requirements. Prepare a map showing the location of all existing screening. Note type of screen, condition and guideline conformance or nonconformance.
- g. Storage of liquids in AST's requires containment controls that can hold the contents of the AST plus a safety factor (usually 110 percent of the tank capacity). These secondary containment areas may collect storm water from rain events. Do not disrupt containment areas with planting.
Remove dirt, leaves, trash, and weeds from the containment area.
- h. Barrier posts or other means shall be provided to protect tanks from vehicular damage. The tank shall be labeled with the product name and 'no smoking' signs shall be affixed. Tanks shall be adequately grounded or bonded to prevent the accumulation of static electricity.
- i. Locate tanks so as not to restrict circulation, or reduce the number of required parking spaces or vehicle back up space. Adequate space should be available to allow for access to the dispensing mechanism by users without interfering with other circulation needs (Figure 3.17-4).



Figure 3.17-3: AST at the Naval Hospital (27) Area, Unscreened from view.



Figure 3.17-4: Unobstructed access to AST.

3.17 C. SCREENING GUIDELINES

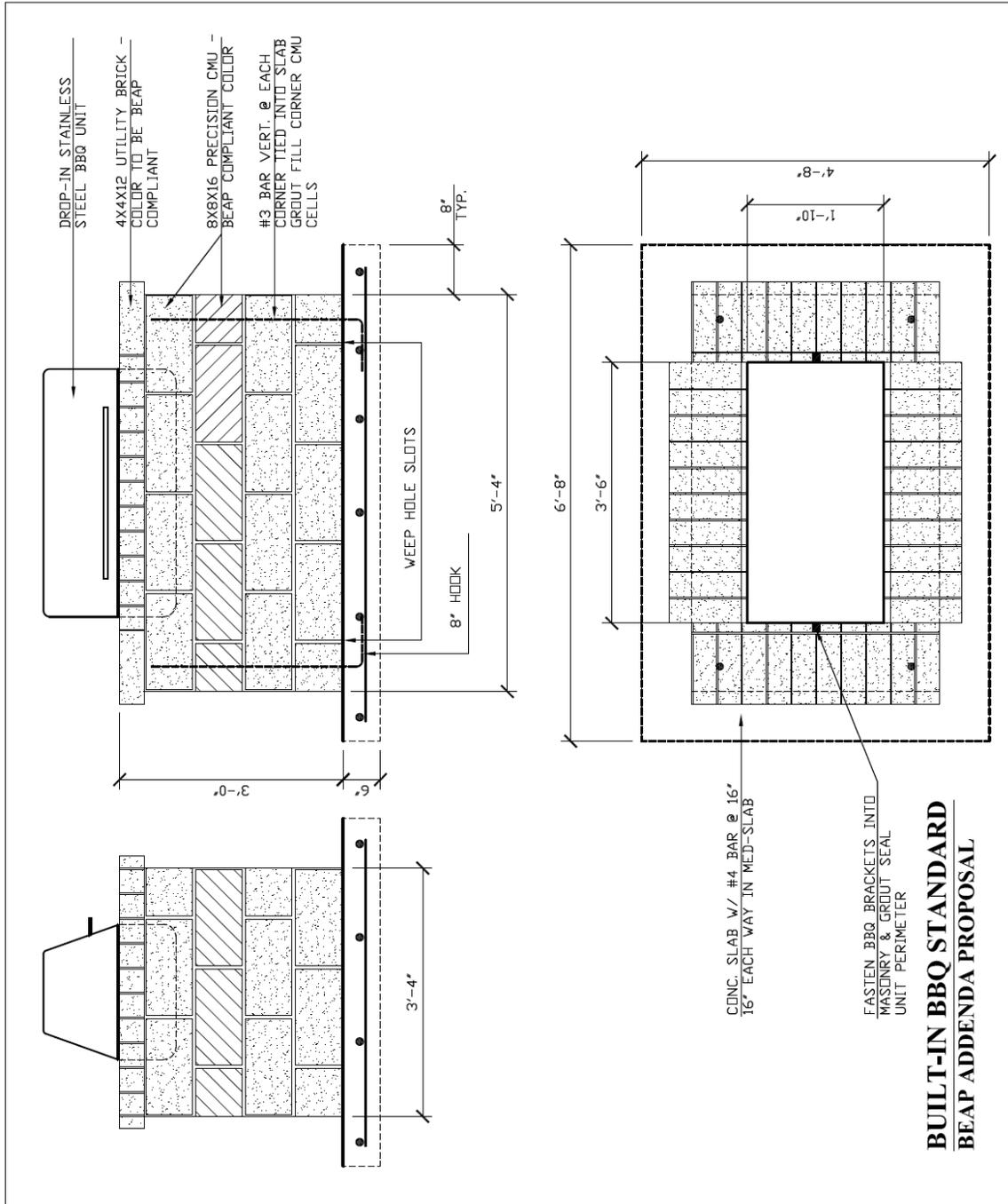
1. FENCES

- a. Use fences where safety and security are needed, such as around electrical substations and where partial view blockage is desirable, such as at service courts and materials storage areas.
- b. Construct screen fences (Figure 3.17-5).
- c. Augment fences with landscaping where screening is desired and irrigation is feasible (see Section 3.6–Landscaping). Landscape planting includes trees only. Shrub planting and hedges are not allowed. Do not use fence slats.

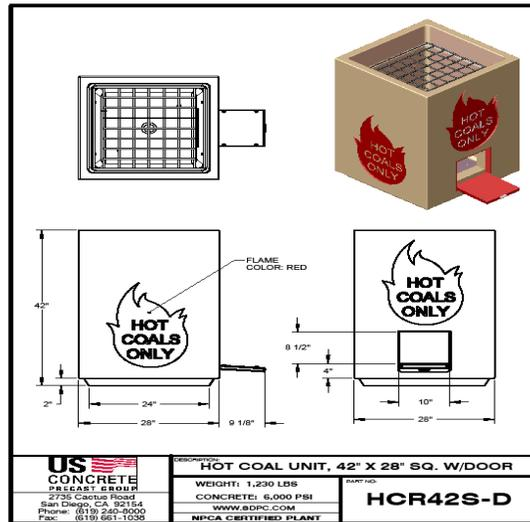


Figure 3.17-5

SELF-HELP BBQ AND CMU COUNTER SURROUND



CHAPTER 8.9E5 HOT CHARCOAL CONTAINER



CHAPTER 8.2A5 DOWNSPOUT and EXTERIOR FOUNDATION

1. Top of any exterior foundation details shall extend above the elevation of the street gutter at point of discharge at the inlet of an approved drainage device a min. 12" plus 2%.
2. Stormwater from downspouts shall be controlled and routed away from the building to a nearby stormwater conveyance system (i.e. storm drain, detention/retention basin, swale, etc.) the route from the downspout to the stormwater conveyance system can be underground or above ground. The route should not cross over or drain onto a sidewalk, walkway or concrete patio area.
3. See also stormwater design standards & storm collection/conveyance systems section.

CHAPTER 8.9I5/16 BOLLARD

1. Bollard color to be yellow.

CHAPTER 11.2 SUBMITTAL MATRIX (SEE PAGE 131)

1. Items 1-4 Submittal requirement for concept design workshop should be 11"x17" (not 8 1/2" x 11").
2. Final architectural building renderings to include building exterior, floor plan and interior, arranged on one board. (perspective drawing graphically)

CHAPTER 12D8 FLAGPOLE

- a. Provide flagpoles that are round, tapered, anodized aluminum **65 feet** high with a hinged base for ease of maintenance. See section 8.9.

CHAPTER 11.2 SUBMITTAL MATRIX

Marine Corps Base Camp Pendleton

11.2 Submittal Matrix

Submittal Requirements Matrix	Concept Design Development Submittal		Construction Document Submittal		Special Notes
	No. of Sets	Set Size	No. of Sets	Set Size	
1. Site Analysis	10	8-1/2" x 11"			
2. Site Plan	10	8-1/2" x 11"	10	Full Size: 24" x 36" Half Size: 11" x 17"	Refer to Chapter 10 for a checklist of minimum information required.
2a. Stormwater Design	10	8-1/2" x 11"	10	Full Size: 24" x 36" Half Size: 11" x 17"	Refer to Chapter 10 for a checklist of minimum information required.
3. Floor Plans	10	8-1/2" x 11"			
4. Rendered Elevations	10	8-1/2" x 11"			Keyed to Color Board
5. Materials Boards:	5	16" x 20"			Provide Title Block per Section 11.6 in the upper right corner of Board. Key to a colored rendering of the buildings' elevation.
5a. Building Color & Material Boards					
5b. Architectural Site Elements					
5c. Photographs of Plant Material					
6. Landscape Plans			10	1/2 size	
7. Architecture Plans			10	1/2 size	
8. Structural Plans			10	1/2 size	
9. Mechanical & Plumbing Plans			10	1/2 size	
10. Electrical Plans			10	1/2 size	
11. Fire Protection Plan			10	1/2 size	If required by code analysis.
12. Project Manual			1		Prepared according to the latest edition in one of the following formats: - Specsintact (Navy) - AIA - CSI
13. Project Cost Estimate			5		
14. Title 24 Energy			3		
15. Erosion Control Plan			10	1/2 size	
16. Geotechnical Report			3		Prepared by a California Licensed Civil Engineer.
17. Review Period for Submittals	21 days		21 days		Provide written response to the government design review per the NAVFAC SW A/E Guide.

APPENDIX A BASEWIDE COLOR

Appendix A

Color Board / Building Materials - Basewide & Rehabilitation

<i>BASEWIDE COLOR STANDARDS - NEW AND EXISTING</i>	
<i>ARCHITECTURAL ELEMENTS</i>	<i>MATERIAL DESCRIPTION</i>
<i>Exterior Walls</i>	<i>Concrete Block-Precision/Split Face</i> - ORCO-Gray RCP-Natural ANGELUS-Warm Gray - ORCO-Cool Gray RCP-Castle Gray ANGELUS-Cool Gray - ORCO-Sourdough RCP-La Paz ANGELUS-Champagne <i>Concrete Block Accent Colors-Precision/Split Face</i> - ORCO-Red Brown RCP- Chestnut ANGELUS-Sienna Brown - ORCO-Black 250 RCP-Charcoal ANGELUS-Slate - ORCO-Wheat RCP-Pueblo ANGELUS-Shoreline
<i>Exterior Finishes for Existing Buildings</i>	<i>Concrete plaster building wall-PANTONE 7528, PANTONE 7536</i>
<i>Roofing</i>	<i>Galvanized metal standing seam roofing with a factory applied Fluor Polymer Coating System resin finish: Color - PANTONE 188</i>
<i>Exterior Doors and Door Frames</i> <i>Window Frames</i> <i>Metal Accent/Trim</i>	<i>All windows and doors-aluminum with a factory applied Fluor Polymer Coating System resin finish of:</i> - PANTONE 405 - PANTONE 188 - PANTONE 7 BLACK 7C
<i>Galvanized Downspouts</i>	<i>Color to match dominant color of building</i>
<i>Gutters and Flashings</i>	<i>Color - PANTONE 188</i>
<i>Handrails and Guardrails</i>	<i>Hot dip galvanized steel</i>
<i>Door Hardware</i>	<i>#304 Stainless Steel, #4 Finish</i>
<i>Site Wall Cap</i>	<i>Saddleback or Peaked</i>

A-2

Color Board Notes:

1. Refer to BEAP - Chapter 3 for additional guidance on the correct application of these standards.
2. The use of scored concrete masonry units (CMU) is acceptable. Use of 4" high block is acceptable.
3. To promote a creative exterior appearance, the final articulation of approved CMU colors & textures is at the discretion of the designer of record; except that one course of precision CMU shall be used adjacent to all finished grades, hardscape, and where "through the wall" penetrations, louvers, and vents occur.
4. CMU mix: Approximate percentages should be as follows: 40% split face and 60% precision block. This is graphically shown in Chapter 3.5a "Exterior Walls" of the BEAP.
5. Use factory applied Fluor Polymer Coating System for all exterior metal & aluminum finishes.
6. Minimize the use of field painted colors & finishes.
7. Guard rails shall be designed for minimal maintenance; use hot-dipped galvanized steel at hand and guardrails.
8. Use finish colors #1 and #2 for exteriors on existing buildings.
9. Downspouts shall match dominant building background color.
10. All deviations from the BEAP shall be reviewed and approved by the Camp Pendleton Public Works Officer during the Concept Development Phase (See BEAP Appendix G for application for exceptions form).

DEPARTMENT OF THE NAVY
MARINE CORPS BASE

NAVAL FACILITIES ENGINEERING COMMAND
PUBLIC WORKS OFFICE CAMP PENDLETON

REVISIONS

APPR	DATE	PREP BY	DESCRIPTION (DATE & SIGN BLOCK)

BASE EXTERIOR ARCHITECTURE PLAN

CMU - COLORS & TEXTURES

(All color samples shown are available in both Precision and Splitface)

PRECISION



(A) ORCO - Gray
RCP - Natural
ANGELUS - Warm Gray

PRECISION



(B) ORCO - Gray (Cool Gray)
RCP - Castle Gray
ANGELUS - Cool Gray

PRECISION



(C) ORCO - Sourdough
RCP - La Paz
ANGELUS - Champagne

SPLITFACE



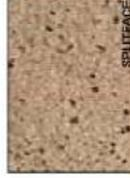
(D) ORCO - Red Brown
RCP - Chestnut
ANGELUS - Siema Brown

SPLITFACE



(E) ORCO - Black 250
RCP - Charcoal
ANGELUS - Slate
(Used as accent, up to 5%)

SPLITFACE



(F) ORCO - Wheat
RCP - Pueblo
ANGELUS - Shoreline

EXTERIOR COLOR & MATERIAL STANDARDS

Notes:

- Refer to BEAP - Chapter 3 for additional guidance on the correct application of these standards.
- The use of scored concrete masonry units (CMU) is acceptable. Use of high block is acceptable.
- To provide a consistent exterior appearance, the final articulation of CMU color and texture at the exterior of the building or project, except that one course of precision CMU shall be used adjacent to all finished grades, hardscape, and where "through the wall" penetrations, louvers, and vents occur.
- CMU mix: Approximate percentages should be as follows: 40% split face and 60% precision block. This is graphically shown in Chapter 3.5a "Exterior Walls" of the BEAP.
- Use factory applied Fluor Polymer Coating System for all exterior metal & aluminum finishes.
- Minimize the use of field painted colors & finishes.
- Guard rails shall be designed for minimal maintenance; use hot-dipped galvanized steel at hand and guardrails.
- Use finish colors #1 and #2 for exteriors on existing buildings.
- Downspouts shall match dominant building background color.
- All deviations from the BEAP shall be reviewed and approved by the Camp Pendleton Public Works Officer during the Concept Development Phase (See BEAP Appendix G for application for exceptions).

FINISH COLORS

EXISTING BUILDING WALLS

(1) PANTONE 7528 **(2) PANTONE 7536**




(3) PANTONE 188
Metal Roof
Doors/Frames
Window Frames



NEW OR EXISTING METAL COMPONENTS

(4) PANTONE 405
Doors/Frames
Window Frames



(5) PANTONE 7
Black 7C
Doors/Frames
Window Frames



DOOR HARDWARE / SITE WALL CAP



DOOR HARDWARE FINISH
#304 St. Steel
#4 Finish



PRECAST WALL CAP
Style:
Saddleback/Peaked
Natural Gray

16" 14 1/2"

18 1/2" 22"

APPENDIX B COLOR BOARD LAYOUT-BASEWIDE & REHABILITATION-RANGES

Marine Corps Base Camp Pendleton

Color Board / Building Materials - Ranges

RANGE COLOR STANDARDS - NEW AND EXISTING	
ARCHITECTURAL ELEMENTS	MATERIAL DESCRIPTION
All Standing Seam Metal Roofs / Doors and Frames	Color - PANTONE 5535 U
Bleachers / Quonsets	Off-White High Reflectance Ceramic Paint (Per Individual Vendor)
Windows / Soffits / Sheds	Color - PANTONE Warm Gray 2U
Tower Base Structures	Color - PANTONE 424 U
Tower Cabins / Bleacher Cover / Sheds	Color - PANTONE 427 C
Exterior Walls	Concrete Block - Precision C.M.U. - ANGELUS-Warm Gray ORCO-Gray RCP-Natural

Color Board Notes:

1. Refer to BEAP - Chapter 3 for additional guidance on the correct application of these standards.
2. The use of scored concrete masonry units (CMU) is acceptable. Use of 4" high block is acceptable. Precision block is preferred.
3. To promote a creative exterior appearance, the final articulation of approved CMU colors & textures is at the discretion of the designer of record; except that one course of precision CMU shall be used adjacent to all finished grades, hardscape, and where "through the wall" penetrations, louvers, and vents occur.
4. Use factory applied Fluor Polymer Coating System for all exterior metal & aluminum finishes.
5. Minimize the use of field painted colors & finishes.
6. Guard rails shall be designed for minimal maintenance; use hot-dipped galvanized steel at hand and guardrails.
7. Downspouts shall match dominant building background color.
8. All deviations from the BEAP shall be reviewed and approved by the Camp Pendleton Public Works Officer during the Concept Development Phase (See BEAP Appendix G for Application for Exceptions).
9. Roof color shall have an SRE of 29 minimum.

APPENDIX B NEW RANGES COLOR BOARD

DEPARTMENT OF THE NAVY
MARINE CORPS BASE

NAVAL FACILITIES ENGINEERING COMMAND
PUBLIC WORKS OFFICE
CAMP PENDLETON

BASE EXTERIOR ARCHITECTURE PLAN

RANGES EXTERIOR COLOR & MATERIAL STANDARDS

DATED: OCTOBER 28, 2011

Notes:

1. Refer to BEAP - Chapter 3 for additional guidance on the correct application of these standards.
2. The use of scored concrete masonry units (CMU) is acceptable. Use of 4" high block is acceptable. Precision block is preferred.
3. To promote a creative exterior appearance, the final articulation of approved CMU colors & textures is at the discretion of the designer of record; except that one course of precision CMU shall be used adjacent to all finished grades, handscapes, and where "through the wall" penetrations, louvers, and vents occur.
4. Use factory applied Fluor Polymer Coating System for all exterior metal & aluminum finishes.
5. Minimize the use of field painted colors & finishes.
6. Guard rails shall be designed for minimal maintenance; use hot-dipped galvanized steel at hand and guardrails.
7. Downspouts shall match dominant building background color.
8. All deviations from the BEAP shall be reviewed and approved by the Camp Pendleton Public Works Office during the Concept Development Phase (See BEAP Appendix G for Application for Exceptions).
9. Roof color shall have an SRE of 29 minimum.




<div style="background-color: #555; width: 40px; height: 40px; margin: 0 auto; margin-bottom: 5px;"></div> <p>(A) PANTONE # 5535 U All Standing Seam Metal Roofs / Doors and Frames</p>	<div style="background-color: #fff; width: 40px; height: 40px; margin: 0 auto; margin-bottom: 5px;"></div> <p>(B) Off-White High Reflectance Ceramic Paint (Per Indiv. Vendor) Bleachers / Quonsets</p>	<div style="background-color: #ccc; width: 40px; height: 40px; margin: 0 auto; margin-bottom: 5px;"></div> <p>(C) PANTONE # Warm Gray 2U Windows / Soffits / Sheds</p>
<div style="background-color: #444; width: 40px; height: 40px; margin: 0 auto; margin-bottom: 5px;"></div> <p>(D) PANTONE # 424 U Tower Base Structures</p>	<div style="background-color: #eee; width: 40px; height: 40px; margin: 0 auto; margin-bottom: 5px;"></div> <p>(E) PANTONE # 427 C Tower Cabins / Bleacher Cover / Sheds</p>	<div style="background-color: #aaa; width: 40px; height: 40px; margin: 0 auto; margin-bottom: 5px;"></div> <p>(F) PRECISION C.M.U. Angelus - Warm Gray ORCO - Gray RCP - Natural</p>

12" 10 1/2" 14 1/2" 16"

MARINE CORP LOGO EAGLE/GLOBE/ANCHOR



PMS STANDARD COLORS

Designation Band:	Old Glory Blue	PMS 280
Letters, Borders and Rope:	Yellow	PMS 136
	-when metallic is used: Bronze	PMS 873
Background:	Scarlet	PMS 200
	Or	Marine Corps Scarlet PMS 185
Device:		
Eagle, Globe, Anchor, Scroll	Gold Brown	PMS 471
	-when metallic is used: Bronze	PMS 874
Shading and Details	Black	PMS 1

Colors provided by:
Institute of Heraldry
www.tioh.hqda.pentagon.mil

3.6D LANDSCAPE GUIDELINES

3. Plant Installations

c. **Maintenance and Establishment Period:** All Landscape Contractors are required to provide a 365 day (1 year) maintenance and establishment warranty period on installed landscapes. A temporary sign is to be provided and located on site to notify users that the site is under warranty. This sign is to include: dates of warranty period, company providing landscape maintenance, contact number to report landscape issues. It should be located in a centralized, clearly visible location and should be durable enough to last through the warranty period. A landscape maintenance checklist and seasonal irrigation schedules shall be included with the Operations and Maintenance Support Information (OMSI) package and provided to the Camp Pendleton Public Works Department (PWD). The Landscape maintenance checklist should outline the frequency and types of tasks to be performed during the maintenance period. The irrigation schedule should outline seasonal and microclimate specific irrigation needs and estimated establishment period. Maintenance logs/reports are to be provided to the PWD at the 6 month and 1 year warranty walks. Proper establishment is critical to the ultimate success of the landscape. At a minimum, the following maintenance tasks are required:

- No vegetation shall be planted near or around backflow devices, hydrants, or any equipment that requires routine maintenance.
- Weeding and Cultivating: The entire site shall be kept free of weeds, noxious grasses, clods, trash and debris on a monthly basis. Hand remove all weeds larger than 3 inches tall or wide. Apply pre-emergent as required.
- Plant Replacement: During the maintenance period, plants which die or are in unhealthy or badly impaired condition shall be replaced by the Landscape Contractor within 1 month after unsatisfactory condition is evident. If plants are replaced during the maintenance period, then the 365 day maintenance period for those plants shall restart at the date of installation and acceptance of the replacement plants.
- Pruning: Prune all plant material as needed and as appropriate on a monthly basis. Remove all dead, diseased or unsightly growth. Pruning is required when necessary to provide horizontal and/or vertical sight line clearances. Prune back groundcover and shrubs overhanging curbs, sidewalks or parking lots. Do not shear plants or create vertical edges; prune them in a manner that enhances the natural form, shape and size. Prune all trees to encourage upward growth and a high branching structure (ultimately, a minimum vertical clearance of 6' in pedestrian areas and 9' in parking/street areas is required for all trees other than those specifically chosen as multi-trunk or low branching specimens for screening). Remove all sucker growth. Tree stakes shall be removed at the end of the maintenance period (Figures 3.6-34-a and 3.6-34-b).
- Mulch and Erosion Repair: Replace mulch that has been washed or knocked out of place. Smooth finish surface of mulch. Repair any erosion damage and provide permanent solution to address cause of erosion.

- *Irrigation Adjustment and Repair: Make irrigation system inspections on the entire system for proper operation and coverage on a monthly basis. Repair and clean/flush as necessary to keep the system in proper, full operation. Adjust spray nozzles to obtain optimum coverage and minimum overspray on hardscape elements, into drains or stormwater facilities. Seasonally adjust irrigation controllers for frequency and cycle length.*



Figure 3.6-34-a Tree stakes grown into tree.



Figure 3.6-34-b Tree stakes broken and girdling tree.

4. Edging

When used at Camp Pendleton, landscape edging must reinforce a durable and easily maintained site design. It should be used when a more formal aesthetic is desired and/or when it reduces maintenance (Figure 3.6-35-c and 3.6-35-f). Designs should not rely exclusively on edging patterns, but should have strong planting and paving concepts. Mulch (organic or inorganic) should not dominate a site. Informal planting design and thoughtful choice of materials can eliminate the need for edging.

- *When used, a 6-inch (6") concrete mow strip is required. In limited circumstances, commercial grade steel, or aluminum edging may be approved by the PWD. This edging shall be brown or black in color to coordinate with mulch (not green) and 4-inch (4") minimum. Redwood, faux-wood (Trex or equivalent), and plastic edgings are prohibited (Figures 3.6-35-a, 3.6-35-b, 3.6-35-d).*
- *Provide a 6-inch (6") concrete mow strip between grass/planted areas and specialized surfaces such as running tracks, exercise stations, horseshoe pits, volley ball courts, etc.*
- *Provide a 6-inch (6") concrete curb edging along the sides of asphalt walkways and parking lots.*



Figure 3.6-35-a Redwood edging warping



Figure 3.6-35-b Trex edging trip hazard



Figure 3.6-35-c Concrete edging used for formal design. Figure 3.6-35-d Wood edging used at edge of asphalt.

5. Ground Cover & Mulch

ALL AREAS DISTURBED DURING CONSTRUCTION SHALL RECEIVE PERMANENT COVER to retain moisture, reduce erosion, and suppress weed growth and seed germination. Permanent cover shall be achieved through a combination of inorganic mulch and planting.

- Inorganic Mulch:* Includes any type of rock (cobble, gravel, disintegrated granite (DG), glass, or rubber chips. Rock mulch shall be minimum three inches (3") thick. Disintegrated granite (DG) shall be four inches (4") thick. Finish grade of mulch shall be 1" below adjacent paving. Weed fabric shall be installed below inorganic mulch. Color shall be coordinated with adjacent sites and building materials.
- Planting (Container Plants with Organic Mulch):* Container plants shall be minimum 1 gallon. Use of smaller containers, such as 4" pots or plugs, may be approved by the PWD on a case-by-case basis, for example, in large bioretention areas where seeding is not viable or practical. Where container plants are intended as permanent ground cover, organic mulch may be used in limited circumstances as temporary cover until plants reach their ultimate size.

Organic mulches include any material of natural origin that decomposes naturally, such as bark chips, grass clippings, straw, leaves, compost, rice hulls, saw dust or gorilla hair. Since they decay over time, they are temporary. As they decay, they provide nutrients.

These temporary mulches will perform the various functions of mulch for approximately 1-2 years. If not replaced, they will lose effectiveness after this period. Organic mulches are generally flammable, some more than others.

The following criteria must be met and clearly noted on plans in order to use organic mulch in this capacity:

- i. Planting beds must have permanent, conventional spray irrigation with full coverage able to keep mulch damp and address fire concerns.*
- ii. Plant quantities, species, and spacing should provide complete ground coverage within one to two years (Figures 3.6-35-e and 3.6-35-f).*
- iii. Mulch must be high quality, absent of trash or construction waste and filtered to remove large pieces over 4 inches long/wide.*
- iv. Planting beds adjacent to natural open space or identified as part of a brush management zone SHALL NOT use organic mulch due to extreme fire danger. Gorilla hair mulch is particularly flammable and must be approved by the PWD on a case by case basis. Refer to the BEAP Brush Management guidelines (3.6 H-9). These areas should be carefully planned and planted with fire resistant species and shall use inorganic mulch.*



Figure 3.6-35-e Full plant cover will not be achieved. mulch/edging.



Figure 3.6-35-f Acceptable use of organic mulch/edging.



Figure 3.6-35-g Example of 100% vegetative cover.

Figure 3.6-35-h Example of poor vegetative cover.

- **Planting (HydroSeeding):** HydroSeeding, sometimes called hydraulic mulch seeding, is a planting process in which a slurry containing seed, hydro seeding mulch, fertilizer and a tackifier (bonding agent) is sprayed onto the ground. HydroSeeding can be an economical and effective way to achieve plant cover over large areas and may be acceptable as a restoration technique. However, inappropriately specified or poorly applied hydroseed is likely to fail and unsuccessful hydroseed applications will not be accepted by the PWD.
 - i. Use personnel or subcontractors certified and trained in the proper procedures for mixing and application of hydroseed/hydromulch as defined by the manufacturers/suppliers specifications and verified by the DOR.
 - ii. Hydroseeding shall NOT be used in areas receiving concentrated flow or on slopes greater than 3:1 unless used in combination with other stabilization techniques.
 - iii. Hydroseeding is not appropriate in highly pedestrian trafficked areas unless species are traffic tolerant and protected until established.
 - iv. Seed mixes must be site specific. Spaces in or adjacent to natural areas and/or intended to be re-vegetated as native scrub should use the Environmental Security approved seed mix as a starting point and should consult with the Environmental Security Department to address specific habitat concerns. Slope planting should focus on long term erosion control and root mass. In populated areas, species should be tolerant of some foot traffic and periodic mowing and are not required to be purely native. Seed rates must be referenced by Pure Live Seed vs. bulk pounds, and native seed must be sourced within 2 counties from Camp Pendleton. Seed mix must contain both fast establishing annuals and permanent, long-lived perennials with substantial root mass.
 - v. Hydroseed should be applied between November and January. Application of hydroseed outside of this planting window greatly reduces the chance of successful establishment, especially with native plants. If necessary, and in general to minimize the period during which a cut or filled surface remains exposed, species that provide rapid short term coverage should be used in combination with species that provide long term permanent coverage. Mowing and re-application of permanent species will likely be necessary during the planting window.

- vi. *Hydroseed shall be irrigated. Permanent, below ground spray irrigation with full head to head coverage is required for most sites within cantonment areas. Above ground, temporary spray irrigation may be approved for Range projects and on a case by case basis for Cantonment Areas, by the PWD. Temporary irrigation must be left in place for 1 year and must be removed at the end of this year. Irrigation with a water truck is generally not successful and will only be approved if no other alternative is available. Non-irrigated hydroseed is rarely successful and will only be approved in extreme circumstances, and when applied/re-applied during the planting window.*
- vii. *Hydroseed shall be applied from two opposing directions to soil surface to achieve optimum soil surface coverage. Rough surfaces (rocky terrain, cat tracks and ripped soils) may require higher application rates to achieve 100% cover. Seedbed shall be prepared according to planting preparation specifications. A two step application is optimal. Hydraulic mulch must be capable of maintaining integrity for minimum 9 Months.*
- viii. *Hydroseed on slopes shall be applied to geotechnically stable slopes that have been designed and constructed to divert runoff away from the face of the slope. Slope interruption devices or water diversion techniques are required when slope lengths exceed 100 feet (30 m). Slopes greater than 3:1, and in excess of fifteen feet in vertical height, shall be planted with shrubs having a one gallon minimum size or trees having a five gallon minimum size. The maximum spacing for shrubs and trees shall be ten feet on center each way.*
- ix. *Permanent plant cover must be established within the 1 year maintenance/establishment period. Establishment will be reviewed at the 6 month and 1 year walks by a government representative. For native species, plants should average 4" tall and 2-4 perennial plants should be present per square foot. Annual species should also be present. At 1 year, coverage of 70%, as compared to the native background plants must be achieved. For turf grass and other non-natives, a minimum of 85% cover is required. If these establishment rates are not achieved at either walk, the contractor is required to re-seed and the maintenance/establishment period for these areas will restart.*



Figure 3.6-35-i Example of well established hydroseeded. Figure 3.6-35-j Example of failed hydroseeded.

3.6 E Irrigation

25. Valve Boxes: Valve boxes should be chosen to blend in with surrounding ground cover. Concrete valve boxes are preferred. For reclaimed water, purple valve boxes must be used. When plastic valve boxes are specified for potable water use, specify tan colored valve boxes when boxes will be located in wood or rock mulch areas. All valve box covers shall have identification label or number attached or engraved to the top of the cover.



Figure 3.6-40-a Green valve boxes in tan gravel.



Figure 3.6-40-b Green valve boxes in organic mulch.

TABLE OF CONTENT
INTERIOR DESIGN STANDARDS FOR CAMP PENDLETON

Division Section	INTERIOR DESIGN STANDARDS	Page
1	<i>PHILOSOPHY</i>	161
2	<i>ACHIEVING THE PHILOSOPHY</i>	161
3	<i>INTERIOR FINISHES</i>	162
4	<i>REPLACEMENT</i>	162
5	<i>INTERIOR DESIGN SPECIFICATION GUIDANCE</i>	163
6	<i>PHOTOGRAPHS: GOOD EXAMPLES</i>	176
7	<i>PHOTOGRAPHS: LESSONS LEARNED</i>	181

1. PHILOSOPHY:

Function

- a. The interior design package should meet or exceed the functional efficiency of the space for the tasks performed.
- b. End users continually move throughout the Base and to other locations due to changes in duties and missions. The goal is to provide an interiors package that reflects the MCB Camp Pendleton standard and should not reflect the specific taste of the current end user or interior designer. By designing to the standard, the space can accommodate the needs of many end users as they move from building to building.
- c. The interiors package should be maintainable, adaptable, functional and durable.

Marine Proof

- a. Think muddy boots, sharp things, big young high energy Marines.
- b. Interiors to be masculine in nature and create a sense of unity
- c. Marines will NOT clean finishes or FF&E (Furniture, Fixtures and Equipment)
- d. O & M Funds for repair or replacement is limited so make design selections accordingly

Timeless Design

- a. A sense of "classic style" and timelessness is encouraged.
- b. Marine Corps motto: "the Few, the Proud, the Marines". The interior design concept shall reflect a proud, military culture.
- c. Produce interiors that Marines will be proud to live and work in.
- d. Designs need to last for a minimum 20-30 years because there are no dollars for repair or replacement.

2. ACHIEVING THE PHILOSOPHY:

FF&E

REQUIRED

- a. Interiors are to commensurate with the rank or level of the individual user (see Figure 1)
- b. Classic medium to medium dark stains of wood for furniture is desirable for higher ranks, such as cherry, walnut or mahogany.
- c. FF&E selections are to be visually appealing to a **male dominated** Marine demographic (think heavy duty: it should LOOK and BE heavy duty yet with a sense of style ...no skinny/minimalist looking furniture).
- d. Patterns and colors of FF&E should hide soiling (medium to dark colors and heavy patterning)
- e. Provide modesty panels on all desks.
- f. Provide cable management at all work areas.
- g. Work surfaces and table top surfaces may be light in color when light reflectance is important, however, wood grain or a small pattern is preferred for soil hiding capabilities
- h. FF&E to be zero to low maintenance making it less expensive to maintain
- i. FF&E to be sustainable, recyclable and environmentally friendly.

PROHIBITED

- j. Style should NOT be ultra modern, trendy or minimalist
- k. Black/Espresso and/or white wood is NOT acceptable for FF&E
- l. Solid fabrics and light colored fabrics are not acceptable (even if they are commercial grade).
- m. Workstations should NOT have low/credenza height work surfaces. Maintain industry standard of 29"-30" high work surfaces.
- n. Binder bins should NOT be hung on panels that are less than 60" high.

- o. Mesh chair backs on office seating should NOT be white or light in color. The oils from hands make the mesh look soiled/dirty. The chairs will NOT be cleaned, so choosing a color that hides soiling is important.
- p. Mesh backs on task chairs should NOT be used at a high use area such as the check in desk at a BEQ Community Center, a control desk at a Fitness Center, etc. The mesh will fail quickly due to the high number of people pulling on the top of the chair as they move in and out of the desk area. A cellular type plastic backed task chair is a better solution.

3. INTERIOR FINISHES

REQUIRED

- a. Patterns and colors of SID (Structural Interior Design) should hide soiling (medium to dark colors and heavy patterning)
- b. Finishes to be zero to low maintenance making it less expensive to maintain
- c. Finishes to be sustainable, recyclable and environmentally friendly

PROHIBITED

- d. Matte sealed concrete flooring should NOT be used except in utility rooms such as electric rooms, mechanical rooms, telephone equipment rooms and in some maintenance work bays. Polished concrete, epoxy, shiny sealer/stained concrete and terrazzo floors are acceptable types of concrete floors for all other areas where a concrete floor is the best solution.
- e. Do NOT use floor tiles that have a surface color/finish that is not integral throughout the body of the tile.
- f. Wall covering should NOT be used (some wall coverings used as artwork/graphics depicting Marines is acceptable).
- g. Black/Esspresso and/or white wood is NOT acceptable for interior building finishes

Required Procedure for FF&E and SID Packages

- a. BEQ FF&E to follow the guidance in the Department of Navy "Policy for Procurement of Bachelor Enlisted Quarters (BEQ) Furniture, Furnishings and Equipment (FF&E) dated AUG 20, 2010.
- b. Follow "Best of Breed" criteria for BEQ complexes
- c. FF&E to comply with NAVFAC Performance criteria.
- d. Follow criteria in the CPR Specification Guidance
- e. All FF&E and SID packages to involve the end user and the Project Leader from Public Works Dept.
- f. The FINAL FF&E and SID packages to be signed off by the Project Leader at Public Works Dept.
- g. Public Works Dept to receive FF&E and SID submittal packages.

4. REPLACEMENT:

1. Replacement and Maintenance

- a. To maintain consistency in the interior design, replacement of an FF&E item or SID interior finish shall duplicate what is currently installed.
- b. If an FF&E item or SID interior finish has been discontinued, alternate items are to be approved by Public Works Department and/or the Director of Billeting for BEQ's.

5. INTERIOR DESIGN SPECIFICATION GUIDANCE

03 35 00	Concrete Finishing
07 08 00	Commissioning of Moisture Protection
09 29 00	Gypsum Board
09 30 00	Tiling

09 65 00	Resilient Flooring
09 66 00	Terrazzo Flooring
09 67 00	Fluid Applied Flooring
09 72 00	Wall Coverings
09 90 00	<i>Paints and Coatings</i>
10 14 00	Signage
10 21 00	Compartments and Cubicles
10 22 10	Partitions
10 26 00	Wall and Door Protection
10 28 00	<i>Toilet, Bath and Laundry Accessories</i>
10 43 00	Emergency Aid Specialties
10 50 00	Storage Specialties
12 10 00	Art
12 21 00	Window Blinds
12 36 00	Countertops
12 41 00	<i>Office Accessories</i>
12 45 00	<i>Bedroom Furnishings</i>
12 48 00	Rugs and Mats
12 51 00	Office Furniture
12 52 00	Seating
12 56 00	Institutional Furniture
12 59 00	Systems Furniture
12 93 00	<i>Site Furnishings</i>
22 42 00	Plumbing Fixtures
41 23 00	<i>Lifting Devices</i>

03 35 00 CONCRETE FINISHING

03 35 00 Sealed Concrete

There is no single sealer which can accommodate all types of projects. There are two main types of sealers: surface sealers (acrylic, epoxy, and urethane) and penetrating sealers (silicone-based). Be sure to specify the type of shine desired: level of sheen or matte. There are more concrete sealers than those mentioned here. The selection of a concrete sealer should be based on the specific need and the desired sheen.

Surface Sealers

1. Surface sealers are the most common sealers used since they protect the surface, also preventing any foreign object to pass through; to include rust, oils, salts, water, urine and other stains and chemicals. A stain or color can be applied with the sealer.
 - a. **Acrylic**
An acrylic concrete sealer is softer compared to the other types. However, this is more suitable for external applications due to its resistance to UV rays. This also lets moisture present in the concrete flow out.
 - b. **Epoxy**
An epoxy concrete sealer is stronger compared to an acrylic sealer. However, it does not allow moisture to escape. Epoxy sealers offer a shiny, clear finish. Epoxy sealers entail more surface preparation and higher costs.
 - c. **Urethane**
A urethane concrete sealer turns out as the strongest yet the most expensive among the types of concrete sealer. Urethane sealers are usually meant for industrial uses.

Penetrating Sealers

1. Penetrating sealers are oftentimes silicon-based. They infiltrate a surface and react to free lime, forming calcium silicate. This process makes it seem like the capillaries and pores are filled with cement. Through this, the concrete will be stronger and water won't migrate to it. This sealer will produce a matte finish.

03 35 43 Polished Concrete Finishing

1. When providing a polished concrete finish, use a multi-step dry mechanical process. Both products and installation shall conform to the manufacturer guidelines. These requirements shall include but are not limited to a lithium silicate densifier, a dry grind process for installation, and a predetermined gloss level:
 - a. Low Gloss – 30-40
 - b. Medium Gloss – 41-60
 - c. High Gloss – 61 & higher
2. All imperfections in existing slab must be addressed and repaired. Best efforts should be made to mitigate the appearance of all imperfections. Inspect the existing substrate and document unsatisfactory conditions in writing. Verify that surfaces and site conditions are ready to receive work. Correct unacceptable conditions prior to installation of System. Commencement of work constitutes acceptance of substrate conditions
3. Polishing aids are required for stain protection.
4. Floor protection is required after installation of polish system and is to remain through the end of construction.
5. Maintenance Data: Provide manufacturer's instructions for maintenance of installed work, including methods and frequency recommended for maintaining optimum condition under intended use. These instructions should contain precautions against cleaning products and methods, which may be detrimental to finishes and performance.
6. Installer must be experienced and factory-trained in the installation and experienced in performing specified work similar in design, products and scope of this project, with a documented track record of successful, in-service performance and with sufficient production capabilities, facilities and personnel to produce specified work. Installer must provide written documentation from the manufacturer confirming the Installer's accreditation and training
7. Mock-Up: Before performing the work in this section, an adequate number of on-site mock-ups must be installed for review and approval. These mock-ups should be installed using the same Installer personnel who will perform work. Approved mock-ups may become part of completed work, if undisturbed at time of substantial completion.
8. Close areas to traffic during and after Polished Concrete System application for a time period recommended by the manufacturer.
9. Existing concrete must be cured for a sufficient time period recommended by manufacturer before the application can begin.
10. Where new or existing concrete is not within specified tolerances a polishable cementitious topping may be installed. Chosen topping must be approved before installation. If moisture tests results exceed recommended limits refer to topical moisture mitigation system recommendations.

11. Must protect existing concrete from contamination by petroleum, oil, hydraulic fluid, acid and acidic detergents, paint and other liquid dripping from trades and equipment working over these substrates. If construction equipment must be used on these substrates, drape all components that may drip fluids.
12. Polished concrete flooring should not be confused with sealed concrete flooring. Polished concrete flooring holds up well on the Base, is easy to maintain and is aesthetically pleasing, unlike sealed concrete (penetrating sealer) which can be hard to clean and looks like raw concrete. A stain or color can be applied. Polished concrete flooring is not suitable for areas that have a high likelihood of standing water as it becomes very slippery when wet. Polished concrete will impact the construction schedule because it will require several days to install/grind and must be coordinated with the contractor at the very beginning of the project.

07 08 00 COMMISSIONING OF MOISTURE PROTECTION

07 08 00 Moisture Testing for Concrete Slabs

1. When installing a finished flooring over a concrete slab, provide a moisture mitigation systems suited to treat areas of new concrete that may still be damp or have very high moisture readings as well as existing concrete to receive all types of flooring where the level of moisture emissions from the slab exceeds the maximum allowed by the manufacturer of the finished floor covering. The moisture testing should be completed using the standard RH Testing Method per ASTM F2170 and the System should be able to handle up to 98% RH (relative humidity sensor).

09 29 00 GYPSUM BOARD

09 29 00 Mildew Resistant Gypsum Board Ceiling

1. Mildew and mold resistant gypsum board should be used for ceilings in areas with high moisture content such as shower rooms and BEQ bathrooms.
2. A gypsum board ceiling is required for all telephone equipment rooms. This type of ceiling will prevent dust and other debris from contacting the telephone service equipment. Gypsum board ceilings are not required for mechanical equipment rooms or electrical rooms.

09 30 00 TILING

09 30 31 Ceramic Tile

1. Ceramic tile is acceptable on wall surfaces, but it is not durable enough for floor surfaces. Floor surfaces on the Base take a high level of abuse. Where a tile floor is called for, a better solution would be porcelain tile where the color is integral through the entire tile or quarry tile (for back of house kitchen areas).

09 65 00 RESILIENT FLOORING

09 65 13 Resilient Base and Accessories

1. Resilient floor base and accessories to be rubber (not vinyl) and to be 6" in height. Light colors are not acceptable as they show dirt, wear/tear and scuff marks.

09 65 19 Vinyl Composition Tile

1. Although the industry is now producing resilient tile flooring with bio-content and other sustainable attributes, the material requires buffing and does not have the longevity of other resilient flooring materials.
2. Vinyl composition tile should only be used in small areas where there is no possibility of moisture problems in the substrate/concrete slab; or there is no other alternative due to budget constraints.

09 65 19 Luxury Vinyl Tile

1. Luxury vinyl tile is desired by the Base. It provides a high degree of durability, is low maintenance and provides soil hiding patterns. Luxury vinyl tile should be 3mm gauge.

09 65 43 Linoleum Flooring

1. Although the sustainable attributes are highly desirable, the durability of the material and the adhesive has not stood the test of time aboard the Base. When resilient flooring is called for, an alternate to linoleum is desired.

09 66 00 TERRAZZO FLOORING

09 66 13 Portland Cement Terrazzo Flooring

09 66 16 Terrazzo Floor Tile

09 66 23 Resinous Matrix Terrazzo Flooring

09 66 33 Conductive Terrazzo Flooring

1. The industry offers many varieties of terrazzo flooring. It is recommended that the interior designer research the types of terrazzo flooring available and select the best type for the end use. Terrazzo flooring should not be confused with polished concrete flooring, sealed concrete flooring or epoxy flooring. Terrazzo flooring holds up well on the Base, is easy to maintain and is aesthetically pleasing, unlike matte sealed concrete which is hard to clean and looks like raw concrete.

09 67 00 FLUID APPLIED FLOORING

09 67 13 Elastomeric Liquid Flooring

09 67 16 Epoxy Marble Chip Flooring

09 67 19 Magnesium-Oxychloride Flooring

09 67 23 Resinous Flooring

09 67 26 Quartz Flooring

09 67 66 Fluid-Applied Athletic Flooring

1. The industry offers many varieties of what is commonly referred to as "Epoxy" flooring. It is recommended that the interior designer research the types of epoxy flooring available and select the best type for the end use. Epoxy flooring should not be confused with

polished concrete flooring, sealed concrete flooring or terrazzo flooring. Some epoxy flooring holds up well on the Base, is easy to maintain and is aesthetically pleasing, unlike matte sealed concrete which is hard to clean and looks like raw concrete. Not all epoxy flooring is durable enough for use on the Base. Some relatively new installations have been failing/peeling up. The material should be a "poured on" application and not "rolled on". Also, the number of layers of the epoxy system should match the durability of the end use.

09 72 00 WALL COVERINGS

1. Wall coverings require maintenance/repair/replacement. *In general*, wall covering is not desired. If wall protection is necessary, another type of material such as diamond metal plate, corner guards, chair rails or tile wainscots are required. Some wall coverings used as artwork/graphics depicting Marines is acceptable when located appropriately (*i.e. out of reach from public/human contact*). *Decorative wallcoverings in low traffic/higher end command suites may be acceptable with approval from PWD.*
2. *Wall covering shall not be applied within the sides of a finished window opening.*

09 90 00 PAINT AND COATINGS

09 91 23 Interior Painting

1. Interior paint to be applied over a minimum Level 3 wall finish. Interior paint to be velvet or eggshell finish unless the area being painted is subject to moisture, such as restrooms and shower rooms, or requires a high degree of clean ability such as a commercial kitchen. These areas shall have semi-gloss.
2. Red paint is a common color used for accent walls. Be aware that in some applications sunlight/artificial light reflecting off of the red paint onto an adjacent light colored wall will make the light colored wall appear pink. The use of accent walls are highly encouraged, but be aware of the location of light sources so that reflections do not create an undesirable effect.

10 14 00 SIGNAGE

10 14 16 Plaques

Interior room identification:

1. Sustainable materials
2. Comply with ADA, ABA and UFC 3-120-10 Interior Design (dated 1 July 2007)
3. Signs to be designed in conjunction with the Comprehensive Interior Design Package.
4. Finishes should be durable (Marine-proof) and outlast the longevity of the building
5. Require zero to low maintenance making them less expensive to maintain
6. Sign package to coordinate with architecture/design of the building.
7. BEQ Individual Living Unit door signs to be 8.5" x 11" printer paper interchangeable.

8. Administrative and other building interior signs to have interchangeable slide in labels under a clear panel strip.
9. Some of the older facilities on the Base have room signs above the door that are mounted perpendicular to the wall. When the facility is renovated, interior room identification signs must be provided that comply with numbers 1-8 above (for purposes of ADA), however, if the end user desires, the perpendicular mounted signs can be provided in addition.

10 21 00 COMPARTMENTS AND CUBICLES

10 21 13 Toilet Compartments

1. Toilet compartment partitions of phenolic, high density plastic (HDP) or solid surface type materials provide the best durability and longevity for Marine environments. Stainless steel or painted metal compartment panels are prone to rusting and plastic laminate compartment panels are prone to de-lamination; and both are prone to scratching/abuse. Graffiti is common (written and scratched) and the partitions need to be highly durable and repairable.

10 22 10 PARTITIONS

10 22 19 Demountable Partitions

1. Demountable interior partitions are considered FF&E and not construction. As an FF&E item, the quality can be controlled by the BVD process. Interior glazing becomes less expensive than traditional interior glazed partitions. There is flexibility in reconfiguring the space without using construction dollars.

10 26 00 WALL AND DOOR PROTECTION

10 26 13 Corner Guards

1. Heavy Duty corner guards either of stainless steel or PVC material to coordinate with surrounding walls on all exterior corners throughout the interiors of all buildings will provide a durable, maintenance free wall finish to gypsum board wall construction. Heavy duty corner guards benefit all building types across the Base from industrial and BEQs to command post/headquarters and administrative buildings. Marines often carry large gear bags throughout all types of buildings and the walls, especially the corners suffer the abuse.

10 28 00 TOILET, BATH AND LAUNDRY ACCESSORIES

10 28 13 TOILET ACCESSORIES

1. *Open front toilet seats to be provided for all toilets.*

10 43 00 EMERGENCY AID SPECIALTIES

10 43 13 Defibrillator Cabinets

1. Defibrillators are proven to save the life of people in cardiac arrest. Defibrillators can be provided at obvious points in a building near a fire extinguisher/one per floor.

10 50 00 STORAGE SPECIALTIES

10 51 26 Recycled Plastic Lockers and

10 51 29 Phenolic Lockers

1. Painted steel lockers are not as durable as recycled plastic or phenolic lockers. Steel lockers rust easily when located in areas with heavy moisture such as shower rooms and training tanks. Recycled plastic or phenolic lockers should have adequate ventilation openings.

10 51 53 Locker Room Benches

1. Seating and/or benches in an area that has lockers and/or showers is desired. Careful attention should be paid that the seating material will not rust or corrode or be damaged easily when located in areas with heavy moisture.

10 55 00 Postal Specialties

1. Provide 6 sets of keys for all FF&E that is lockable such as file cabinets, overhead binder storage, etc. The keys should be presented to the end user in a key box with labels indentifying each key.

12 10 00 ART

12 11 00 Murals

12 12 00 Wall Decorations

12 14 00 Sculptures

12 17 00 Art Glass

1. The use of artwork is encouraged on the Base. Creativity in the display of artwork is also encouraged. Alternatives to a framed and matted piece of art or photograph should be considered. Of all the armed forces, the Marines are the branch that passionately celebrates the history of their missions, their leadership and their background. Historical photographs as well as photographs of present day missions are welcome artwork themes. The use of original artwork from local artists is highly encouraged.

12 21 00 WINDOW BLINDS

12 21 23 Roll-Down Blinds and

12 21 26 Black-Out Blinds

1. Traditional mini blinds break easily and are noisy when a breeze comes through an open window. A roll-down blind system/solar shade system provides a mesh fabric and manually operated chain drive hardware mounted at the window in a channel system. This type of window treatment is much more durable and, when paired with a black out shade, provides filtered sunlight or total black out conditions.

12 36 00 COUNTERTOPS

12 36 61 Solid Surface Countertops

1. Solid surface material provides a durable, repairable countertop surface. Plastic laminate countertops are not durable for a Marine environment. When used in a bathroom, a solid surface integral sink makes the lavatory easy to clean. Porcelain coated cast iron is not permitted.

12 41 00 OFFICE ACCESSORIES

12 41 13 Computer Keyboard Trays/Drawers

1. A computer keyboard tray/drawer is to be provided at each workstation and desk to comply with ADA. Some end users do not use the keyboard tray/drawer, so a type needs to be specified that is capable of being completely pushed/moved out of the way of the end users knees without any tools or special instructions.

12 45 00 BEDROOM FURNISHINGS

12 45 13 Bed Linens

1. FF&E packages to include mattress covers that prevent bed bugs.
2. A washable, durable blanket in lieu of a fitted bed cap or bedspread desired.

12 48 00 RUG AND MATS

12 48 13 Entrance Mats

1. Entrance mats are to be provided at both the interior and exterior of all entrances to buildings.

12 48 43 Chair Mats

1. Chair mats are useful to extend the life of carpet at workstations and desk areas. Chair mats should be provided at all carpeted workstation and desk areas and should be extra heavy duty to withstand the weight of big Marines. The chair mats should withstand a weight of at least 300 pounds and should have a warranty of at least 5 years or more.

12 51 00 OFFICE FURNITURE

12 51 16 Case Goods

1. Style should be classic and timeless
2. Interiors should match the rank or level of the individual user
3. Classic medium to medium dark stains of wood for furniture is desirable for higher ranks, such as cherry, walnut or mahogany.
4. Patterns and colors should hide soiling

5. Should visually appeal to a male dominated Marine demographic (think heavy duty: it should LOOK and BE heavy duty yet with a sense of style ...no skinny/minimalist looking furniture).
6. Low, credenza height returns are not acceptable. Maintain industry standard of 29"-30" high work surfaces.
7. Provide modesty panels on all desks.
8. Work surfaces and table top surfaces may be light in color when light reflectance is important (such as in some training rooms), however, wood grain is preferred for soil hiding capabilities
9. Require zero to low maintenance making them less expensive to maintain
10. Sustainable, recyclable and environmentally friendly
11. Public Works Department Project Leader to sign off on all FF&E and SID packages
12. Style should not be ultra modern, trendy or minimalist
13. Black/Esspresso and/or white wood are NOT acceptable for FF&E or interior building finishes.
14. All case goods (new and replacement) to comply with NAVFAC performance criteria.

12 52 00 SEATING

12 52 19 Upholstered Seating

1. Upholstered seating should not be white or light in color. The oils from hands make the fabric look soiled/dirty. The seating will not be cleaned, so choosing a color that hides soiling is important.
2. Choose fabrics that are dark in color and/or heavily patterned to hide soiling. Engineered fabric systems with an integral moisture barrier that promises permanent resistance to stains and spills is desirable for some applications.

12 52 23 Office Seating

1. Chair backs on office seating should not be white or light in color. The oils from hands make the fabric mesh/rubber mesh/textile fabric look soiled/dirty. The chairs will not be cleaned, so choosing a color that hides soiling is important.
2. Choose a seat fabric that is dark in color and/or heavily patterned to hide soiling. Engineered fabric systems with an integral moisture barrier that promises permanent resistance to stains and spills is desirable for some applications.
3. All seating (new and replacement) to comply with NAVFAC performance criteria

12 56 00 INSTITUTIONAL FURNITURE

12 56 43 Dormitory Furniture

1. Superior quality, solid wood construction with lockable compartments for storage of large gear/packs
2. Ability to secure room and personal belongings.
3. FF&E that appeals to the new Y generation Marine demographic nationwide.
4. FF&E should be space planned with the USMC approved furniture standard.
5. Color and texture introduced to create visually pleasing, stimulating environments.
6. Longer warranties will save Marine Corp dollars
7. FF&E to be coordinated with the design of the building
8. Style should not be ultra modern, trendy or minimalist
9. Black/Espresso and/or white wood are NOT acceptable for FF&E or interior building finishes.
10. All dormitory furniture (new and replacement) to comply with NAVFAC performance criteria.

12 59 00 SYSTEMS FURNITURE

12 59 13 Panel Hung Component System Furniture

1. Workstations should NOT have low/credenza height work surfaces. Maintain industry standard of 29"-30" high work surfaces.
2. Binder bins should NOT be hung on panels that are less than 60" high
3. Style should not be ultra modern, trendy or minimalist
4. Black/Espresso and/or white wood are NOT acceptable for FF&E or interior building finishes.
5. All systems furniture (new and replacement) to comply with NAVFAC performance criteria.

12 93 00 SITE FURNISHINGS

12 93 43 Site Seating and Tables

1. The use of outdoor spaces is encouraged by placing suitable seating and tables in gathering areas.
2. The outdoor furniture should be made of materials that do not require painting or ongoing maintenance.
3. The outdoor furniture should be Marine proof (i.e. heavy duty, scaled to comfortably accommodate large people) and it should be bolted to the ground to prevent vandalism or moving to other areas. Outdoor furnishings located on a balcony or secured private patio area need not be bolted to the ground.

22 42 00 PLUMBING FIXTURES

22 42 23 Showers

1. Wrap solid surfacing material from shower surround all the way to adjacent door frames and walls to prevent drywall damage from moisture.
2. Shower pans to be prefabricated solid surface and extend up wall behind solid surface shower surround wall panels ensuring a water tight condition.

22 42 39 Faucets

1. Water savings is important to the Base. Faucets with batteries that regulate the duration of water requires replacement of the battery; *which might not happen depending on funding or manpower available*. Self metering faucets are acceptable.

41 23 00 LIFTING DEVICES

41 23 23 Fork Lifts

1. **Definition of GME Garrison Mobile Equipment:**
Per Marine Corps Order P11240.106B:
 - a. *GME consists of commercially available owned, leased and otherwise controlled passenger carrying vehicles, cargo vehicles, and material handling equipment, engineer equipment and railway rolling stock. The term passenger carrying includes sedans, station wagons, ambulances, buses, sport utility vehicles (SUVs), and passenger vans. GME fleet managers operate their GME fleets in support of transportation and maintenance requirements at Marine Corps activities. They will not use their GME fleet for tactical purposes, nor will they deploy GME assets. The essential characteristic that clearly identifies GME is wheels or tracks. Equipment similar to GME that does not move on its own power and/or is not wheeled or tracked equipment is not GME. (Example: A forklift is GME; a non-motorized pallet jack is FF&E.*
2. **Centralized Equipment Pool:**
Per MCIWESTO 11240.3:
 - a. *Pooling of equipment, both physically and administratively, to the maximum extent possible is essential to economize effort, maximize service facilities, and ensure effective use of GME. The Fleet Site Managers and GME Responsible Officers (RO's) will establish centralized GME pools and sub pools based on mission, distance, economy, effectiveness, functionality, and other factors. Site Mangers will establish a consolidated equipment pool to provide general support to many users and refrain from assigning assets for the exclusive use by one section or individual.*
3. **Official Use of GME:**
 - a. *GME are for Official Use Only. Determination of "Official Use" will be in strict compliance with the statutory regulations, DoD 4500.36-R, MCO P11240.106B and the policies of MCIWESTO 11240.3. Only military and civilian personnel are allowed to operate GME. They will not use government vehicles to conduct personal business or engage in activities of a personal nature. Official use does not include stopping at the commissary, mess hall, exchange, or fast food restaurants, etc. GME*

will not be authorized for transporting personnel over any part of the route between their domicile and work location.

- b. GME will not be assigned to an individual or billet unless specifically authorized, in writing, by headquarters Marine Corps (HQMC).*

4. Requesting of any type of GME:

The following steps need to be taken when a unit decides that they need GME assigned on a permanent basis:

- a. Complete the Vehicle / Equipment Assignment Justification Form (on following page) and submit it to the unit major command (i.e. MLG, DIV).*
- b. The major command should review their currently assigned GME to see if they can reassign equipment internally to accommodate that new requirement.*
- c. If the new requirement cannot be accommodated internally, the major command will forward the request with their recommendations to the Regional Inventory Manager Southwest Regional Fleet Transportation sharon.augusto@usmc.mil 760-725-3583. The request will then be considered with the Site Manager for that base.*
- d. Processing will include an analysis of vehicles currently assigned to the respective major command. SWRFT looks for possibilities to increase the efficiency of assets currently assigned to the command. If it is not possible to utilize current assets to meet the new or changed vehicle requirement, SWRFT will then consider reassignment of vehicles within the Camp Pendleton fleet and the SWRFT Region fleet. Increasing SWRFT's inventory is not an option without specific authorization from Headquarters Marine Corps.*
- e. If the requested equipment is USMC owned and has been approved for procurement, the request will be included with the annual HQMC Procurement Priority List submitted for each base. This submission usually occurs during the July-August timeframe. HQMC will then decide what will be purchased and provide the most benefit for the entire Marine Corps considering available procurement funding. Note: The items purchased will arrive in the following year at the earliest. It's recommended that in the planning phase of any warehouse modernization/improvement programs that requires additional material handling equipment (MHE), that the additional MHE requirements be identified during that stage to allow time for the procurement process.*

5. Warehouse Modernization Program:

- a. **All GME is centrally managed at the HQMC level.** SWRFT is responsible for the HQMC authorized Table of Equipment (T/E) for GME. Any equipment that will be bought, either through the Warehouse Modernization program or through HQMC utilizing Procurement, Marine Corps funding, will need to go through the SWRFT Inventory office before the purchase to properly manage the inventory and the T/E allowances.*
- b. GME for MCCS (Marine Corps Community Services) projects will not follow the procedure above but will need to be coordinated through MCCS management.*



VEHICLE / EQUIPMENT ASSIGNMENT JUSTIFICATION (Class B - Full Time Assignment to Support Daily Requirements)

References: DoD 4500.36-R and MCO P11240.106 govern Garrison Mobile Equipment (GME) and require the adequate justification of Class B assigned GME. Instructions: Only complete forms will be accepted. This completed form is required to justify retaining currently assigned GME, request new/additional GME, and to request a change in GME type (i.e. 12-pax van to 7-pax van, 10k forklift to 6k forklift, etc.).

Responsible Officer (RO) Name		RO Phone #		Date	
Command/Activity		JON (if applicable)		SWRFT Dept ID	
Justification for:		New GME		Change GME	
Tag / ID #		Est. Annual Miles / Hours		Usual # Passengers	
Description of GME required to accomplish mission (7- pax van, pickup truck, 4k forklift, etc.):					
Special equipment required to accomplish mission (lift gate, tow hitch, ladder rack, etc.)					
Justification for GME Class B assignment (Explain in detail why this GME is required):					
Explain why currently assigned equipment, POV, pooled GME, or bus service cannot be utilized:					
Signature of Responsible Officer		Date		Signature of Authorizing Official	
				(This MUST be an Official authorized to commit funding for GME support.)	

**BASE INTERIORS PROGRAM RANK CHART
FURNITURE LEVELS**

MILITARY OFFICERS					
NAVY	MARINE CORPS		EQUIVALENT GS LEVEL	FURNITURE LEVEL	NOTES
Fleet Admiral - 5 Star	FADM	General - 4 Star	Senior Executive Level	Tier I	Same as Level A in Garrison Property Policy Manual
Admiral - 4 Star	ADM	Lieutenant General - 3 Star			
Vice Admiral - 3 Star	VADM	Major General - 2 Star	GS-16, 17, 18		
Rear Admiral Upper Half - 2 Star	RADM	Brigadier General - 1 Star			
Rear Admiral Lower Half - 1 Star	RADM	Colonel	GS-15		
Captain	CAPT	Lieutenant Colonel	GS-13-14	Tier II	Same as Level B in Garrison Property Policy Manual
Commander	CDR	Major			
Lieutenant Commander	LCDR	Captain	GS-12	Tier III	Same as Level C in Garrison Property Policy Manual
Lieutenant	LT	First Lieutenant	GS-10-11		
Lieutenant Junior Grade	LTJG	Second Lieutenant	GS-8-9		
Ensign	ENS		GS-7		
COMMISSIONED OFFICERS					
NAVY	MARINE CORPS		EQUIVALENT GS LEVEL	FURNITURE LEVEL	NOTES
Chief Warrant Officer 5	CW05	Chief Warrant Officer 5	GS-9-9	Tier III	Same as Level C in Garrison Property Policy Manual
Chief Warrant Officer 4	CW04	Chief Warrant Officer 4			
Chief Warrant Officer 3	CW03	Chief Warrant Officer 3			
Chief Warrant Officer 2	CW02	Chief Warrant Officer 2	GS-7		
Chief Warrant Officer	CW01	Chief Warrant Officer 1			
ENLISTED					
NAVY	MARINE CORPS		EQUIVALENT GS LEVEL	FURNITURE LEVEL	NOTES
Master, Chief Petty Officer of the Navy	MCP ON	Sergeant Major of the Marine Corps	GS-6	Tier III	Same as Level C in Garrison Property Policy Manual
Master Chief Petty Officer	MCP O	Sergeant Major			
Senior Chief Petty Officer	SCPO	Master Gunnery Sergeant			
Chief Petty Officer	CPO	First Sergeant			
Petty Officer 1 st Class	PO1	Master Sergeant			
Petty Officer 2 nd Class	PO2	Gunnery Sergeant	GS-5		
Petty Officer 3 rd Class	PO3	Staff Sergeant	GS-4		
Seaman	SN	Sergeant			
Seaman Apprentice	SA	Corporal			
Seaman Recruit	SR	Lance Corporal			
		Private First Class	GS-1-3		
		Private			
		Private (no insignia)			
		Pvt			
		Midshipman			

5.FF&E RANK CHART: Level of FF&E based on Military Rank or Civilian GS Level
Figure 1

6. PHOTOGRAPHS: GOOD EXAMPLES

Soil hiding color, pattern and texture

 <p>Darker colored patterned fabrics and flooring will help to hide soiling and wear.</p>	 <p>Darker colored patterned carpet helps to hide soiling and wear.</p>
 <p>Darker colored patterned fabrics to hide soiling.</p>	 <p>Patterned flooring in entry ways and high traffic areas help to hide dirt and wear.</p>

GOOD EXAMPLES
Commensurate with rank office Suites.



Manager's Office



General's Office



Command Deck mess area



Command Deck reception area

GOOD EXAMPLES Meeting Spaces



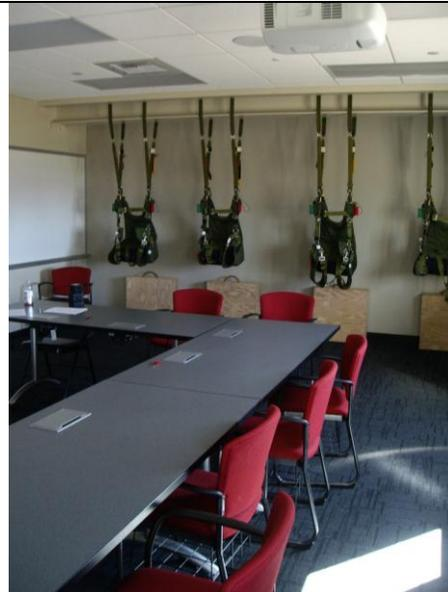
Public areas to have furniture that is attractive, vandal proof, secured to the ground, sturdy and sized appropriately for marines.



Business center can double as casual meeting spaces.



Conference centers to include AV/Media equipment.



Training spaces can be customized to accommodate the instruction of specific skills.

GOOD EXAMPLES
Creative Interior Features



Interior signage to coordinate with interior design concept.



Solid surface window sills create a durable surface that is easy to clean and requires zero maintenance.



Interior glass partitions allow light to penetrate into interior spaces creating a more pleasant work environment.



A variation in ceiling heights creates a more dynamic space.



A contemporary version of a Command Board.



Artwork does not have to be a framed poster.

GOOD EXAMPLES
Work Stations



A typical 8x8 u-shape workstation is successful in many applications.



A wardrobe or locker is to be included in all workstations.



Shared workstations can be designed to meet the needs/use of the space.



Workstation components can be applied to private offices to help maximize storage.

7. PHOTOGRAPHS: LESSONS LEARNED



Mesh chair backs do not hold up in high use areas such as a check in desk.



Mesh chair backs are acceptable for many applications but the lighter fabric colors show soiling at the top of the chair from oil/dirt from hands.



Solid, light colored fabrics will show soiling. This credenza unit will be used as a foot rest; coffee cup/drink lay down area, etc. The fabric will get stained and will not get cleaned or replaced due to limited funds.



White furniture will not hide soiling and will readily show scratches and wear. Wood grain or a darker color is a better choice.

LESSONS LEARNED
Office Furniture



The small scale and color of this furniture is too feminine for marines.



Marines do not want to crawl under their desk to get to their bookshelves.



The scale of this furniture is too small and minimalist for marines.



This storage cabinet is too big for binders but too small for wardrobe.

LESSONS LEARNED
Cable Management



Coordinate electrical to avoid running cables across top of carpet.



Wire/cable management to be provided.
Modesty panels to be provided.

LESSONS LEARNED
Interior Design Features



Dark paint finishes will show scratches and dings. Corner guards are required at all corners throughout a project.



Long corridors need creative design ideas to create interest and make them visually appealing. This design falls short.



Keep it simple-Utilizing several wood grain plastic laminate finishes does not add any value to the design.

OMSI - OPERATION AND MAINTENANCE SUPPORT INFORMATION

At the completion of a building project, the contractor is required to submit an OMSI (Operation and Maintenance Support Information binder(s))to the government. The OMSI will be kept on file with FMD (Facilities and Maintenance Department) to assist in maintaining the building. Below is a checklist to aid in the assembly of the OMSI binder(s). In addition to the hard copy binder(s), an electronic version to be provided on a CD.

CHECK LIST BY: Sunnee Lavulavu	DEPT: FMD-Facilities Maintenance Dept.	PHONE: 760-725-3485	DATE: APRIL 2012
OMSI- OPERATION AND MAINTENANCE SUPPORT INFORMATION CHECKLIST			
		DOCUMENT FORMAT	
A	BINDER	3 ring binder, clear pockets on front binder, water & grease resistant, hold 8.5 x 11 sheets, high quality paper, dividers with heavy duty paper with plastic reinforced holes and integrated tab. Each numbered section to have its own tab. Each sub section within each section to be separated with a divider.	
B	COVER	Appropriate title (PART I, II, III), Building #, Project title, Activity & Bldg number, Contract Number, prepared by:, and Volume number	
C	Electronic Format	Adobe Acrobat 9.0/PDF file, replicates hard copies, indexed by Part I (Facility Information), Part II (Primary Systems Information), etc. PDF is bookmarked and has capacity to search keywords/product name/equipment etc. including asbuilts to be bookmarked. Computerized Maintenance Management System (CMMS) data can be imported into Maximo CMMS. Excel format for Part I number B equipment and warranty tags listing. Provide a CD of the completed OMSI along with the binder.	
	SECTION	PART I – FACILITY INFORMATION AND SYSTEM DESCRIPTION	
1	Facility Information & System Description	Detail the overall dimensions of the facility, # of floors, foundation type, expected # of occupants, facility category code/building type. <u>Photographs marked up and labeled</u> to show key components and the overall facility appearance. <u>A copy of final "Completion Certification."</u>	
2	Basis of Design	Show basic design scope of work, assumptions, original intention of the design A/E, final copy of "Design Quality Control Report Certification"	
3	Safety Hazard	List of all the residual hazards identified in the requirement hazard analysis prepared by the design A/E. Provide recommended safeguards for each identified hazard.	
4	Floor Plans	Legible 11x17 floor plans, clear room numbers, function of space, facility dimensions (NOT instruction, references, frame number etc.)	
5	Utility Connections and Cutoff Plan	Utility site plans floor plans that indicate the main interior and exterior connection and cutoff points for ALL UTILITIES in their designated colors (sewer=green, water=blue, gas=yellow, red=power, orange=comm. Etc). Including photovoltaic, hydrocarbon chambers, disconnects, splice box. Indicate room #, panel #, circuit breaker, valve #, etc. explaining how & what the connection or cutoff is controlling.	OMSI – PAGE 1

6	Equipment Warranty Tags & Guarantors Local Representative	Provide sample of the tag with each warranty name, address, tel. # of guarantor rep nearest to the location, date of acceptance QC signature blank until final/BOD. Letter from the guarantor honoring the warranty during the warranty period. Tag shall be durable, oil & water resistant tag with copper wire and water proofed.	
7	Extended Warranty Information	List and copies of all warranties for products, equipment, components, and subcomponents that exceed one year. Cross reference the list to warranty copies in Part III (Product Data), each warranty listed indicates applicable specifications sections, duration, start date, end date and point of contact, list of references ALL specific O&M procedure that must be performed to keep warranty valid.	
8	Equipment and Warranty Tags listing	EXCEL Table that lists the major equipment shown in the design: equipment schedules and written warranties for equipment/product provided, Photovoltaic, hydrocarbon chambers, bioclean box filters... Show item descriptions, warranty information, locations model numbers name and # of manufactures, suppliers & KTR	
9	HVAC Filters	Table that lists quantity, type size, and location of each HVAC filter	
10	Floor Covering, Wall surfaces, Ceiling surfaces	Table that lists by room #, area, type of finish. Table will include a facility summary of total area for each type of space and floor, wall, and ceiling finish	
11	Windows	Table that lists by room #, area, type of window, window size, # of each size and type and special features. Facility summary of total of each type and size of window	
12	Light Fixtures	Table that lists by room #, type of light fixture, # of lights fixtures, type of bulbs or tubes, and # of bulbs/tubes. Facility summary of total # of fixtures of each type and # of bulbs/tube of each type.	
13	Plumbing fixtures	Table that list by room #, # and type of plumbing & bathroom plumbing fixtures. (sink, toilets, urinals, showers and drinking fountains)	
14	Roofing	Total area of each type of roof surface and system. Name of roofing product & system with manufacture, supplier, installer, address and phone numbers. Recommended inspection, maintenance, and repair schedule that details checkpoints, frequencies and prohibit practices for each type of roof. List roof structural load limits. Location of roof warranty	
	SECTION	PART II – PRIMARY SYSTEMS INFORMATION	
1	Primary Systems Information	Interfaces of equipment, connections and material flow within the system, throughout each section “caution and warning” related to that section. Also include equipment that will require annual certification in each system. For example the cranes at all maintenance bay require annual certification.	
2	Domestic Water pressure boosting systems	Highlight or cloud  system installed with components, pumps, connection, additional loads to system, product data, etc. Each operation shall have the following: OPERATION: System description, start-up and shutdown procedures, Normal and Emergency operating	OMSI – PAGE 2

		<p>Instruction, System Flow Diagrams, Diagrammatic Plans, Field Test Reports, Operator Servicing Requirements, Valve Lists and special requirements.</p> <p>PREVENTATIVE MAINTENACE: procedure, schedule, task card for each individual maintenance task identified on the PM plan and schedule. Detailed PM procedures, safety instruction and precautions, req'd skill level, number of personnel needed, frequency, special tools needed, parts needed and estimated time req'd to complete task. Lubrication schedule indicating types, grades and capacities.</p> <p>TROUBLESHOOTING GUIDES AND DIAGNOSTIC TECHNIQUES: Step by step for isolation system malfunctions, sequential instructions, checks and tests to be performed, determine of cause, remedial measures to bring condition to operating condition. Identify special test equipment req'd to perform the procedures. Start the troubleshooting guide at the system level and proceed to a level where detailed manufacturer procedures for equipment and components can be referenced. Clear reference to repair procedures included in PART II (product data).</p>	
3	Plumbing Systems	<p>Including temp. Actuated thermostatic water missing valves, chlorinator, storm drain and irrigation. Highlight or cloud ☁ system installed with components, pumps, connection, additional loads to system, product data, etc. Each operation shall have the following:</p> <p>OPERATION: System description, start-up and shutdown procedures, Normal and Emergency operating Instruction, System Flow Diagrams, Diagrammatic Plans, Field Test Reports, Operator Servicing Requirements, Valve Lists and special requirements.</p> <p>PREVENTATIVE MAINTENACE: procedure, schedule, task card for each individual maintenance task identified on the PM plan and schedule. Detailed PM procedures, safety instruction and precautions, req'd skill level, number of personnel needed, frequency, special tools needed, parts needed and estimated time req'd to complete task. Lubrication schedule indicating types, grades and capacities.</p> <p>TROUBLESHOOTING GUIDES AND DIAGNOSTIC TECHNIQUES: Step by step for isolation system malfunctions, sequential instructions, checks and tests to be performed, determine of cause, remedial measures to bring condition to operating condition. Identify special test equipment req'd to perform the procedures. Start the troubleshooting guide at the system level and proceed to a level where detailed manufacturer procedures for equipment and components can be referenced. Clear reference to repair procedures included in PART II (product data).</p>	
4	HVAC System	<p>Include chiller, boilers, heat pumps, air handler, exhaust fans, fan coils units, VAV, heat recovery wheels, hydronic systems, control valves and BFP. Highlight system installed with components, pumps, connection, additional loads to system, product data, etc. Each operation shall have the following:</p> <p>OPERATION: System description, start-up and shutdown procedures, Normal and Emergency operating Instruction, System Flow Diagrams, Diagrammatic Plans, Field Test Reports, Operator Servicing Requirements, Valve Lists and special requirements.</p> <p>PREVENTATIVE MAINTENACE: procedure, schedule, task card for each individual maintenance task identified on the PM plan and schedule. Detailed PM procedures, safety instruction and precautions, req'd skill level, number of personnel needed, frequency, special tools needed, parts needed and estimated time req'd to complete task.</p>	OMSI – PAGE 3

		<p>Lubrication schedule indicating types, grades and capacities.</p> <p>TROUBLESHOOTING GUIDES AND DIAGNOSTIC TECHNIQUES: Step by step for isolation system malfunctions, sequential instructions, checks and tests to be performed, determine of cause, remedial measures to bring condition to operating condition. Identify special test equipment req'd to perform the procedures. Start the troubleshooting guide at the system level and proceed to a level where detailed manufacturer procedures for equipment and components can be referenced. Clear reference to repair procedures included in PART II (product data).</p>	
5	DDC/Space Temperature Controls	<p>Highlight or cloud  system installed with components, pumps, connection, additional loads to system, product data, etc. Each operation shall have the following:</p> <p>OPERATION: System description, start-up and shutdown procedures, Normal and Emergency operating Instruction, System Flow Diagrams, Diagrammatic Plans, Field Test Reports, Operator Servicing Requirements, Valve Lists and special requirements.</p> <p>PREVENTATIVE MAINTENACE: procedure, schedule, task card for each individual maintenance task identified on the PM plan and schedule. Detailed PM procedures, safety instruction and precautions, req'd skill level, number of personnel needed, frequency, special tools needed, parts needed and estimated time req'd to complete task. Lubrication schedule indicating types, grades and capacities.</p> <p>TROUBLESHOOTING GUIDES AND DIAGNOSTIC TECHNIQUES: Step by step for isolation system malfunctions, sequential instructions, checks and tests to be performed, determine of cause, remedial measures to bring condition to operating condition. Identify special test equipment req'd to perform the procedures. Start the troubleshooting guide at the system level and proceed to a level where detailed manufacturer procedures for equipment and components can be referenced. Clear reference to repair procedures included in PART II (product data).</p>	
6	Electrical Systems	<p>Including transformers, diesel electric generators, ATS, switchgear, HV switches, VFD, frequency converters, photovoltaic, communication, energy saving equipment and data. Highlight or cloud  system installed with components, pumps, connection, additional loads to system, product data, etc. Each operation shall have the following:</p> <p>OPERATION: System description, start-up and shutdown procedures, Normal and Emergency operating Instruction, System Flow Diagrams, Diagrammatic Plans, Field Test Reports, Operator Servicing Requirements, Valve Lists and special requirements.</p> <p>PREVENTATIVE MAINTENACE: procedure, schedule, task card for each individual maintenance task identified on the PM plan and schedule. Detailed PM procedures, safety instruction and precautions, req'd skill level, number of personnel needed, frequency, special tools needed, parts needed and estimated time req'd to complete task. Lubrication schedule indicating types, grades and capacities.</p> <p>TROUBLESHOOTING GUIDES AND DIAGNOSTIC TECHNIQUES: Step by step for isolation system malfunctions, sequential instructions, checks and tests to be performed, determine of cause, remedial measures to bring condition to operating condition. Identify special test equipment req'd to perform the procedures. Start the troubleshooting guide at the system level and proceed to a level where detailed manufacturer procedures for</p>	OMSI – PAGE 4

		equipment and components can be referenced. Clear reference to repair procedures included in PART II (product data).	
7	Fire Protection Systems and Fire alarm and detections systems	<p>Highlight or cloud  system installed with components, pumps, connection, additional loads to system, product data, etc. Each operation shall have the following:</p> <p>OPERATION: System description, start-up and shutdown procedures, Normal and Emergency operating Instruction, System Flow Diagrams, Diagrammatic Plans, Field Test Reports, Operator Servicing Requirements, Valve Lists and special requirements.</p> <p>PREVENTATIVE MAINTENACE: procedure, schedule, task card for each individual maintenance task identified on the PM plan and schedule. Detailed PM procedures, safety instruction and precautions, req'd skill level, number of personnel needed, frequency, special tools needed, parts needed and estimated time req'd to complete task. Lubrication schedule indicating types, grades and capacities.</p> <p>TROUBLESHOOTING GUIDES AND DIAGNOSTIC TECHNIQUES: Step by step for isolation system malfunctions, sequential instructions, checks and tests to be performed, determine of cause, remedial measures to bring condition to operating condition. Identify special test equipment req'd to perform the procedures. Start the troubleshooting guide at the system level and proceed to a level where detailed manufacturer procedures for equipment and components can be referenced. Clear reference to repair procedures included in PART II (product data).</p>	
8	Site mechanical utilities	<p>Including cathodic protection, hydrocarbon filter, bioclean trash filters, hydroup flow filter and any oil/water separator. Highlight system installed with components, pumps, connection, additional loads to system, product data, etc. Each operation shall have the following:</p> <p>OPERATION: System description, start-up and shutdown procedures, Normal and Emergency operating Instruction, System Flow Diagrams, Diagrammatic Plans, Field Test Reports, Operator Servicing Requirements, Valve Lists and special requirements.</p> <p>PREVENTATIVE MAINTENACE: procedure, schedule, task card for each individual maintenance task identified on the PM plan and schedule. Detailed PM procedures, safety instruction and precautions, req'd skill level, number of personnel needed, frequency, special tools needed, parts needed and estimated time req'd to complete task. Lubrication schedule indicating types, grades and capacities.</p> <p>TROUBLESHOOTING GUIDES AND DIAGNOSTIC TECHNIQUES: Step by step for isolation system malfunctions, sequential instructions, checks and tests to be performed, determine of cause, remedial measures to bring condition to operating condition. Identify special test equipment req'd to perform the procedures. Start the troubleshooting guide at the system level and proceed to a level where detailed manufacturer procedures for equipment and components can be referenced. Clear reference to repair procedures included in PART II (product data).</p>	
9	Site electrical utilities	<p>Including substations, transformers pad mounted switchgear, all PV converter boxes, disconnects, vaults, poles. Highlight or cloud  system installed with components, pumps, connection, additional loads to system, product</p>	OMSI – PAGE 5

		<p>data, etc. Each operation shall have the following:</p> <p>OPERATION: System description, start-up and shutdown procedures, Normal and Emergency operating Instruction, System Flow Diagrams, Diagrammatic Plans, Field Test Reports, Operator Servicing Requirements, Valve Lists and special requirements.</p> <p>PREVENTATIVE MAINTENACE: procedure, schedule, task card for each individual maintenance task identified on the PM plan and schedule. Detailed PM procedures, safety instruction and precautions, req'd skill level, number of personnel needed, frequency, special tools needed, parts needed and estimated time req'd to complete task. Lubrication schedule indicating types, grades and capacities.</p> <p>TROUBLESHOOTING GUIDES AND DIAGNOSTIC TECHNIQUES: Step by step for isolation system malfunctions, sequential instructions, checks and tests to be performed, determine of cause, remedial measures to bring condition to operating condition. Identify special test equipment req'd to perform the procedures. Start the troubleshooting guide at the system level and proceed to a level where detailed manufacturer procedures for equipment and components can be referenced. Clear reference to repair procedures included in PART II (product data).</p>	
10	Wastewater pump stations	<p>Including alarm points, stand alone, or unity connection, lift station. Highlight or cloud  system installed with components, pumps, connection, additional loads to system, product data, etc. Each operation shall have the following:</p> <p>OPERATION: System description, start-up and shutdown procedures, Normal and Emergency operating Instruction, System Flow Diagrams, Diagrammatic Plans, Field Test Reports, Operator Servicing Requirements, Valve Lists and special requirements.</p> <p>PREVENTATIVE MAINTENACE: procedure, schedule, task card for each individual maintenance task identified on the PM plan and schedule. Detailed PM procedures, safety instruction and precautions, req'd skill level, number of personnel needed, frequency, special tools needed, parts needed and estimated time req'd to complete task. Lubrication schedule indicating types, grades and capacities.</p> <p>TROUBLESHOOTING GUIDES AND DIAGNOSTIC TECHNIQUES: Step by step for isolation system malfunctions, sequential instructions, checks and tests to be performed, determine of cause, remedial measures to bring condition to operating condition. Identify special test equipment req'd to perform the procedures. Start the troubleshooting guide at the system level and proceed to a level where detailed manufacturer procedures for equipment and components can be referenced. Clear reference to repair procedures included in PART III (product data).</p>	
	SECTION	PART III - PRODUCT DATA/CONSTRUCTION SUBMITTALS	
1	Construction Submittals	Asbuilts, CD's, Asbuilt product, materials, equipment. Construction submittal register, O&M data, materials, equipment, data sheets, test reports, warranties, equipment certificates, open rework list, shop drawings and training CD's with POC information and attendance sheet.	OMSI – PAGE 6

**SAN DIEGO NORTHERN RAILWAY
REQUIREMENTS FOR THE INSTALLATION OF
PIPELINES ON RAILROAD RIGHT-OF-WAY**

PART 1- GENERAL

Preface

These requirements govern the installation of all pipelines by third-parties within the railroad right-of-way. All pipelines crossing railroad right-of-way shall be encased in a larger pipe or conduit called the "casing pipe" for their entire length. Pipelines shall be installed by boring or jacking, if practicable, and when practicable shall be located in a manner such that they cross tracks perpendicularly. Design of pipelines shall be such that their construction does not interfere with railroad operations. Inspection and maintenance of pipelines shall not interfere with railroad operations. Note that operations within the right-of-way are subject to the Federal Railroad Administration and SDNR's Roadway Worker Protection rules and regulations as well as the rules and regulations for contractors working in SDNR's right-of-way.

Reference Standards

Pipelines shall comply with all local, State, and Federal codes, specifications, standards, and recommended practices, in addition to standards and recommended practices specific to the railroad industry.

The following references shall apply:

- A. Standard Specifications for Public Works Construction
- B. State of California Construction Safety Orders
- C. California Civil Code, Section 182
- D. American Welding Society
- E. Occupational Safety and Health Administration
- F. American Association of State Highway and Transportation Officials
- G. American National Standards Institute
- H. American Railway Engineering and Maintenance of Way Association
- I. California Public Utilities Commission General Orders 26-D and 118
- J. Federal Railroad Administration Roadway Worker Protection Rules
- K. SDNR Engineering Standards

PART 2 - PIPELINES FOR FLAMMABLE SUBSTANCES

Steel Carrier Pipe

Pipelines that carry oil, liquefied petroleum gas, and other flammable liquid products shall be of steel and conform to the requirements of the current ANSI B 31.4 Liquid Transportation Systems for Hydrocarbons, Liquid Petroleum Gas, Anhydrous Ammonia, and Alcohols, and other applicable ANSI codes, except that the maximum allowable stress for design of steel pipe shall not exceed the following percentages of the specified minimum yield strength (multiplied by longitudinal joint factor) of the pipe as defined in the above codes:

- 1. Seventy two percent (72%) for oil pipelines.
- 2. Fifty percent (50%) for pipelines carrying condensate, natural gasoline, natural gas liquids, liquefied petroleum gas, and other liquid petroleum products.
- 3. Sixty percent (60%) for gas pipelines.

Pipe shall be laid with sufficient slack such that it is not in tension.

Casing Pipe

Casing pipe shall be of steel and of leakproof construction, capable of withstanding railway loading. The inside diameter of the casing pipe shall be at least 2 inches greater than the largest outside diameter of the carrier pipe, joints, or couplings for carrier pipe less than 6 inches in diameter and at least 4 inches greater for carrier pipe 6 inches and over in diameter. It shall, in all cases, be great enough to allow the carrier pipe to be removed subsequently without disturbing the casing pipe or roadbed. All joints or couplings, supports, insulators, or centering devices for the carrier pipe within a casing in the railroad right-of-way shall be taken into account when determining the proper casing size.

When casing is installed without the benefit of a protective coating or the protective coating is not cathodically protected, the wall thickness shall be increased to the nearest standard size which is a minimum of 0.063 inches greater than the thickness required, except for diameters under 12 ¼ inches.

Steel pipe shall have a specified minimum yield strength, S.M.Y.S., of at least 35,000 psi.

Table 1. Minimum Wall Thickness for Steel Casing Pipe for E80 Loading

NOMINAL DIAMETER (Inches)	WHEN COATED OR CATHODICALLY PROTECTED - NOMINAL THICKNESS (Inches)	WHEN NOT COATED OR CATHODICALLY PROTECTED - NOMINAL THICKNESS (Inches)
12 ¼ and under	0.188	0.188
14	0.188	0.250
16	0.219	0.281
18	0.250	0.312
20 and 22	0.281	0.344
24	0.312	0.375
26	0.344	0.406
28	0.375	0.438
30	0.406	0.469
32	0.438	0.500
34 and 36	0.469	0.531
38	0.500	0.562
40	0.531	0.594
42	0.562	0.625
44 and 46	0.594	0.656
48	0.625	0.688
50	0.656	0.719
52	0.688	0.750
54	0.719	0.781
56 and 58	0.750	0.812
60	0.781	0.844
62	0.812	0.875
64	0.844	0.906
66 and 68	0.875	0.938
70	0.906	0.969
72	0.938	1.000

Casing pipe shall be constructed as to prevent leakage of any substance from the casing throughout its length.

Casing pipe under railroad tracks and across railroad right-of-way shall not be less than 6 feet from top of lowest railroad rail to the top of the casing at its closest point (Figure 1). On portions of the right-of-way

where casing is not directly beneath any track, the depth from the ground surface or from bottom of ditches to the top of the casing shall not be less than 4 feet (Figure 1). Ends of the casing pipe shall be suitably sealed.

Vent Pipes

Casing pipe shall be properly vented. Vent pipes shall be of sufficient diameter, but in no case less than 2 inches in diameter. Vent pipes shall be attached near the end of the casing pipe and project through the ground surface and shall be outside the railroad right-of-way. Vent pipes shall not extend less than 4 feet above ground surface. Top of vent pipe shall be fitted with a turned-down elbow properly screened, or a relief valve. Vents in locations subject to high water shall be extended above the maximum elevation of high water and shall be supported and protected in a manner that meets SDNR's approval. Vent pipes shall be no closer than 4 feet (vertically) from aerial electric wires.

Shut-Off Valves

Accessible emergency shut-off valves shall be installed within effective distances each side of the railroad as mutually agreed to by SDNR and the pipeline company. These valves should be marked with signs for identification. Where pipelines are provided with automatic control stations at locations and within distances approved by SDNR, no additional valves shall be required.

Carrier Pipe Inspection and Testing

ANSI codes current at the time of construction of the pipeline shall govern the inspection and testing of the facility within the railroad right-of-way except:

1. One hundred percent (100%) of all steel pipe field welds shall be inspected by radiographic examination and such welds shall be inspected for one hundred percent (100%) of the circumference of the pipe.
2. The proof testing of the strength of the carrier pipe shall be in accordance with ANSI requirements.

Approval of Plans

Plans for the proposed installation shall be submitted to and shall be approved by SDNR before construction commences. Plans shall be drawn to scale showing the relation of the proposed pipeline to the railroad tracks, angle of crossing, location of valves, railroad survey stations, right-of-way lines and the arrangement of the tracks and railroad facilities. Plans should also show a cross section (or sections) from field surveys, showing pipe in relation to the actual profile of ground and tracks.

The Contractor shall complete and submit the *Proposed Pipeline Crossing Information Form* included herein under Table 3.

PART 3 - PIPELINES FOR NON-FLAMMABLE SUBSTANCES

Carrier Pipe

Carrier pipe and joints shall be of acceptable material and construction as approved by SDNR. The pipe shall be laid with sufficient slack so that it is not in tension. Acceptable plastic carrier pipe materials include Polyvinyl Chloride (PVC), Acrylonitrile Butadiene Styrene (ABS), Polyethylene (PE), Polybutylene (PB), Cellulose Acetate Butyrate (CAB), and Styrene Rubber (SR). Thermoset types include Reinforced Plastic Mortar (RPM), Reinforced Thermosetting Resin (RTR), and Fiberglass Reinforced Plastic (FRP).

Plastic pipe material shall be resistant to the chemicals with which contact can be anticipated. Plastic carrier pipe shall not be utilized where there is potential for contact with petroleum contaminated soils or other non-polar organic compounds that may be present in surrounding areas.

Design shall consider differential settlement of attachments, longitudinal bending, shear loadings due to uneven settlement of pipe bedding, temperature induced stresses, ground movement due to seasonal variations in moisture content (i.e. expansive clays), seismic ground movement, and potential for ground cover surface erosion.

The plastic pipe material must be compatible with the type of product conveyed and the temperature range anticipated for the transported materials and surrounding environment. The maximum allowable operating pressure is 100 psi. Plastic carrier pipe design and installation shall conform to the ANSI B31.3 specifications and/or the following specifications (Table 2):

Table 2

Specification Number	Carrier Pipe Properties
ANSI / AWWA C900-89	Polyvinyl Chloride (PVC) pressure pipe, 4 in. through 12 in. for water distribution
ANSI / AWWA C901-96	Polyethylene (PE) pressure pipe and tubing, ½ in. through 3 in. for water service
ANSI / AWWA C902-88	Polybutylene (PB) pressure pipe and tubing, ½ in. through 3 in. for water service
ANSI / AWWA C905-88	PVC water transmission pipe, nominal diameters 14 in. through 36 in.
ANSI / AWWA C906-90	PE pressure pipe and fittings, 4 in. through 63 in. for water distribution
ANSI / AWWA C907-90	PVC pressure fitting for water, 4 in. through 8 in.
ANSI / AWWA C950-95	Fiberglass pressure pipe

Codes, specifications, and regulations current at the time of constructing the pipeline shall govern the installation of the facility within the railroad right-of-way. The proof testing of the strength of the carrier pipe shall be in accordance with ANSI requirements.

Steel Casing Pipe

Requirements shall be the same as for steel casing for pipelines carrying flammable substances.

Shut-Off Valves

Requirements for shut-off valves shall be the same as for pipelines carrying flammable substances.

Approval of Plans

Requirements for the approval of plans shall be the same as for pipelines carrying flammable substances.

PART 4 - ALL CASING INSTALLATIONS

Casing Submittals

The contractor will provide a mill certificate of compliance for steel casing.

Casing Installation Plan Submittal

The contractor shall submit a Casing Installation Plan to SDNR for approval prior to performing any work. Indicate locations of jacking and receiving pits relative to the track. Describe method of jacking and

boring including method of grouting annular space between casing and excavated soil. For directional boring/drilling, submit complete specifications for the machine to be used including:

1. Operating and maximum pressures of liquid at the drilling head
2. Water volume
3. Type of reamer or cutting tool and size of holes/nozzles on the head, and method of head control

Handling of Material

Casing and ancillary items shall be handled in such a manner as not to damage the Material. Damage to the casing, lining, or coating, if any, shall be repaired to the satisfaction of SDNR. Casing shall not be dropped to or dragged over the ground, but shall be handled with rolling slings on skids or with cranes. Bent or otherwise damaged casing or ancillary items shall not be used.

Excavation

Excavation shall be performed in accordance with NCTD Standard Specification Section 02160 Excavation Support System. Jacking and receiving pits shall be at least 25' clear of the nearest track centerline.

Jacking and Boring, Jacking and Tunneling

The jacking and boring method consists of pushing the casing into the earth with a boring auger rotating inside the casing, which removes the spoil. The front of the pipe shall be provided with mechanical arrangements or devices that prevent the auger from leading the casing so that no unsupported excavation is ahead of the casing.

The jacking and tunneling method consists of pushing the casing into the earth with jacks and excavation being performed by worker(s) using handheld tools from within the jacking shield at the head of the casing.

Jacking and boring, and/or jacking and tunneling shall not be used in sandy, loose, or otherwise unstable soils or where boulders are anticipated. The use of water or slurry under pressure (jetting) or puddling shall not be permitted to facilitate boring, pushing, or jacking operations. Water or slurry used to lubricate the cutter and pipe is acceptable.

In all operations, the annular space between the casing and the soil shall be grouted. Such grout shall contain at least 8 sacks of cement per cubic yard of material. The hole diameter resulting from bored or tunneled installations shall not exceed the outside diameter of the casing by more than 1.5 inches for casings of less than 12 inches in outside diameter and by 2 inches for casings of greater than 12 inches in outside diameter. For casings with drainage culvert carrier pipes, the annular space between the casing and the carrier pipe shall be grouted. Such grout shall contain at least 8 sacks of cement per cubic yard of Material.

Should the operation be abandoned before completion, the annular space between the casing and excavated soil shall be grouted as specified above. In addition, the complete inside of the casing shall be grouted. Such grout shall contain at least 2 sacks of cement per cubic yard of material.

Operations shall be stopped for the passage of trains. The Contractor shall employ methods to prevent loss of the excavation face as approved in advance by the SDNR.

Operations shall be stopped if ground displacement is detected. The Contractor shall develop a remediation plan that is approved by SDNR before resuming operations. The Contractor is liable for all damage resulting from ground displacement. Should the track displace, corrective action shall be taken by the SDNR forces or the contractor as approved by SDNR. SDNR expenses shall be reimbursed by the Contractor.

Casing installation under track shall be progressed on a continuous basis without stoppage (except for adding casing sections) until the leading edge of the pipe has reached the receiving pit.

For casings with carrier pipes that are other than drain culvert pipes, the annular space between the casing and carrier pipe at the casing ends shall be sealed with a concrete bulkhead with a thickness equal to annular space or 6" which ever is greater.

Directional Boring and Drilling

This method consists of utilizing specialized drilling equipment and boring a small diameter pilot hole along the desired horizontal and vertical alignment, using a mechanical cutting head with high-pressure bentonite slurry to remove the cuttings. Bore pits at either end of the installation are not necessarily required with this method. The drill string is advanced with the bentonite slurry pumped through the drill string to the cutting head and then forced back along the drill string, carrying the cuttings back to the surface for removal. After the cutting head reaches the far side of the crossing, it is removed and a reamer (with a diameter wider than the cutting head) is attached to the lead end of the drill string. The casing is attached to the reamer and the casing is then pulled back into its final position. Methods that excavate the soil by means of jetting of fluid or slurry are not allowed. Directional boring/drilling may be used for casings 12" or less in diameter.

Slurry use shall be kept to a minimum and shall only be used for head lubrication and/or spoils return. The Contractor shall calculate anticipated slurry use and shall monitor actual slurry use during the boring operation in order to determine the slurry loss into the surrounding soil. Slurry shall be bentonite slurry. The bentonite slurry shall seal the annular space between the casing and the excavated soil with a minimum return of 95%.

Bore stems or cutting tools that become immovable under the track shall be abandoned in place. Should the operation be abandoned before completion, the complete inside of the casing shall be grouted. Such grout shall contain at least 2 sacks of cement per cubic yard of Material.

Operations shall be stopped if ground displacement is detected. The Contractor shall develop a remediation plan that is approved by SDNR before resuming operations. The Contractor is liable for all damage resulting from ground displacement. Should the track displace, corrective action shall be taken by the SDNR forces or the Contractor as approved by SDNR. SDNR expenses shall be reimbursed by the contractor.

Table 3 – Proposed Pipeline Crossing Information Form – to be completed and submitted to SDNR

	CARRIER PIPE	CASING PIPE
Contents to be handled		
Outside Diameter		
Pipe Material		
Specification and Grade of Pipe Material		
Wall Thickness		
Actual Working Pressure		
Type of Joint		
Coating		
Method of Installation		
Vents: Number: Size: Height Above Ground: Subject to Immersion: Yes / No		
Seals: Both Ends: One End: Type:		
Bury: Top of Rail to Top of Casing: Ft. In.		
Bury (Not beneath tracks): Ft. In.		
Bury (Roadway Ditches): Ft. In.		
Type, Size, and Spacing of Insulators of Supports:		
Distance: Centerline of Track to Face of Jacking/Receiving Pits: Ft. In.		
Bury: Base of Rail to Bottom of Jacking/Receiving Pits: Ft. In.		
Cathodic Protection: Yes / No		

Proposed Pipeline Crossing Information Form

					Carrier Pipe	Casing Pipe
Contents to be handled						
Outside Diameter						
Pipe Material						
Specification and Grade of Pipe Material						
Wall Thickness						
Actual Working Pressure						
Type of Joint						
Coating						
Method of Installation						
Vents						
Number		Size		Height Above Ground		Subject to Immersion
Seals						
Both Ends		One End		Type		
Bury						
Top of Rail to Top of Casing					Ft.	In.
Not beneath tracks					Ft.	In.
Roadway Ditches					Ft.	In.
Base of Rail to Bottom of Jacking/Receiving Pits					Ft.	In.
Distance from Centerline of Track to Face of Jacking/Receiving Pits					Ft.	In.
Type, Size, and Spacing of Insulators of Supports						
Cathodic Protection						

Note: This form can be completed by the Contractor but can only be submitted to NCTD by the Public Works Project Leader. Per MCB/NCTD Protocol dated 1994 as amended.

Three Mile Pit Rules

1. Three Mile Pit operating hours are Monday through Friday from 0800 to 1600 daily. Three Mile Pit will be closed on all Federal Holidays.
2. Three Mile Pit is only permitted to accept **clean** fill dirt, **uncontaminated** concrete, **fully cured** asphalt, rock, clay and clay products, brick, stone, tile, and ceramics. **All other materials are prohibited** from disposal at Three Mile Pit.
3. Loads that contain prohibited material (common examples include: dry wall, electrical wiring, wood, trash, concrete "washout" waste, sludge, and drilling mud) will **NOT** be accepted at Three Mile Pit.
4. Concrete must have been "cured" for a period of one year before it can be disposed of at Three Mile Pit. Rebar can **NOT** extend more than 6 inches from the concrete.
5. Three Mile Pit will **NOT** accept in process bituminous mixes; asphalt must be "fully cured" before it can be accepted.
6. Three Mile Pit will **NOT** accept inert debris greater than 36 inches in any dimension.
7. The Three Mile Pit manager is required to conduct random load checks of vehicles utilizing the site.
8. Speed limit on the Three Mile Pit access road is 15 mph. 5 mph when passing dismantled troops. Drivers will exercise caution at all times when passing troops and/or military vehicles utilizing "Afghan Village" or the Kilo II training area.
9. All vehicles will be weighed at the Scale House and are subject to load inspection.
10. The vehicle driver will complete the "landfill use permit" and give it to the scale operator along with the company name and where the load came from.
11. Violation of Three Mile Pit Rules can result in a warning and/or a suspension of disposal privilege for the offending party.

Present Purpose.

The Three Mile Pit is a site restoration project. The primary purpose of the Three Mile Pit Contractor is to operate and manage an Inert Debris Engineered Fill Operation (IDEFO) for Camp Pendleton. Inert debris (primarily asphalt & concrete) will be disposed of in accordance with California Code of Regulations, Titles 14, 22, and 27. The goal is to restore Three Mile Pit to the original topography and return a pristine environment back to the Marines in support of their training mission.

Definitions from CCR, Title 14

Definitions:

"Inert Debris Engineered Fill Operation" means a disposal activity exceeding one year in duration in which fully cured asphalt, uncontaminated concrete (including steel reinforcing rods embedded in the concrete), brick, ceramics, clay and clay products, which may be mixed with rock and soil, are spread on land in lifts and compacted under controlled conditions to achieve a uniform and dense mass which is capable of supporting structural loading as necessary, and having other characteristics appropriate for an end use approved by all governmental agencies having jurisdiction where an engineered fill is required to facilitate productive use of the land.

"Fully Cured Asphalt" means that the material must be at ambient temperature, be substantially hardened and be inelastic.

"Site Restoration" means removing unprocessed or processed solid waste and recyclable material from the site to allow reuse of the property.