

U S DEPARTMENT OF COMMERCE  
CHARLES SAWYER, *Secretary*  
COAST AND GEODETIC SURVEY  
LEO OTIS COLBERT, *Director*

---

*Special Publication No 249*

---

TOPOGRAPHIC  
MANUAL  
PART II  
PHOTOGRAMMETRY

*by*

LIEUTENANT COMMANDER L W Swanson  
*U S Coast and Geodetic Survey*



UNITED STATES  
GOVERNMENT PRINTING OFFICE  
WASHINGTON 1949

---

For sale by the Superintendent of Documents U S Government Printing Office Washington 25 D C  
Price \$3 25 (Buclram)

## PREFACE

The Coast and Geodetic Survey is preparing a new topographic manual in which are stated the general requirements of the Bureau for topographic surveys and for photogrammetry. This manual is one of a series covering the various operations of the Bureau. The new manual is being published in two parts—Part I will contain the requirements and detailed instructions for field topographic surveys, including planetable surveys without using aerial photographs and photogrammetric field surveys made for the compilation of maps from aerial photographs, when available, Part I will supersede Special Publication No 144, Topographic Manual, and all prior instructions for field photogrammetric surveys. Part II contains the requirements and detailed procedures for all photogrammetric operations except photogrammetric field surveys.

Part II is published first because the need for this part of the Topographic Manual is more urgent. The requirements of Part II supersede all prior instructions on the pertinent subjects, including the preliminary lithographic issues of some separate chapters.

The subject matter in Part II is identified by a decimal numbering system and all referencing is by these numbers. The reader should understand the significance of these numbers. Each chapter, of which there are nine, is divided into not more than nine sections. Each section is subdivided into not more than nine subjects and each subject into not more than nine numbered headings. The first digit of a number identifies the chapter, the second digit the section, the third digit the subject, and the fourth the heading. For example, **1317**, Review Section, is the **seventh** heading under the **first** subject in the **third** section of chapter **1**, entitled Preliminary Office Procedures. The illustrations and tables are also identified by an unusual numbering system, whereby they are numbered consecutively within each chapter, for example, figure 67 is the seventh figure in the sixth chapter.

Part II of the Topographic Manual has been prepared under the direction of Captain K. T. Adams, Chief, Division of Photogrammetry. Much valuable advice and assistance have been received from personnel of the Baltimore and Tampa Photogrammetric Offices and the Washington Office. Many personnel contributed to the actual compilation of the text, but special credit is due the following personnel of the Washington Office of the Division of Photogrammetry: to Mr. G. C. Tewinkel who wrote Chapter 3, Photogrammetric Theory, and Chapter 6, Stereoscopic Plotting Instruments, and who assisted with other parts of the manual, to Mr. Ralph Moore Berry who wrote Chapter 2, Aerial Photography, and to Mr. Bennett G. Jones for the preparation of Chapter 7, Records and Reports, Chapter 8, Washington Office Completion, and Chapter 9, Miscellaneous, and for reviewing the entire manuscript.

# CONTENTS

## CHAPTER 1—PRELIMINARY OFFICE PROCEDURES

	Page
11 General statement	1
12 Requirements for map accuracy	2
121 National Standards of Map Accuracy	
122 Coast and Geodetic Survey map accuracy	
13 Outline of operations	5
131 Photogrammetric office organization	
132 Photogrammetric office	
14 Equipment and instruments for photogrammetric offices	13
141 Instruments	
142 Furniture	
143 Ratio reflecting projectors	
144 Stereoscopes	
15 Project planning—photogrammetric offices and field parties	30
151 Project instructions for topography and planimetry	
152 Coordination of parties	
153 Project layouts and graphic indexes	
154 Project source material	
155 Classified data	
156 Ordering photographs	
157 Photographs for field work	
158 Adequacy of photography	
159 Control planning	

## CHAPTER 2—AERIAL PHOTOGRAPHY

21 General statement	57
211 Coast and Geodetic Survey use of aerial photographs	
212 Season and weather	
22 Cameras and materials	59
221 Lens requirements	
222 Single-lens cameras	
223 The nine-lens camera	
224 The Trimetrogon Camera	
225 Film	
226 Filters	
23 Airplanes, instruments, and accessories	77
231 Airplane and flight personnel	
232 Operation	
233 Instruments for aerial photography	
24 General instructions for aerial photography	88
25 Flight planning	95
26 Laboratory processing and records	97
261 Laboratory processing	
262 Inspection and indexing	
263 Types of reproductions	
264 Printing equipment	

## CHAPTER 3—PHOTOGRAMMETRIC THEORY

31 Optical principles	100
311 The function of a lens	
312 The idea of light rays	
313 The lens-pinhole analogy	
314 Snell's law of refraction	
315 The simple lens law	
316 Nodal points	
317 Magnification	
318 Lens aberration	
319 The aerial camera lens	
32 The vertical aerial photograph	107
321 Comparison of a photograph with a map	
322 Scale, focal length, and flying height	
323 Relief displacement	
324 The theory of flight planning	
325 Theory of radial plotting	
326 Parallax and elevations	
327 Analytic problems	
33 Stereoscopy	109
331 The human eye	
332 The sensation of relief	
333 Deformations in the stereoscopic model	
334 Instructions for orienting photographs for stereoscopic viewing and for stereoscopic training	
335 The floating mark	
34 The near-vertical photograph	107
341 Definitions and nomenclature	
342 Some geometric principles	
343 Tilt displacement	
344 The effect of tilt on scale	
345 Summary of the effects of tilt	
346 Analytic problems involving tilt	
347 Application of solid analytic geometry	
35 Tilt determination	188
351 The displacement method	
352 The scale point method	
353 Other methods of tilt determination	

	Page
36 Rectification	199
361 Condition of sharp definition	362 Focal length of a rectifier lens
362 Focal length of a rectifier lens	363 The paral-
363 The paral-	lelogram principle
364 Derivation of formulas	365 Simplification of the formulas
365 Simplification of the formulas	366 The use of component angles
366 The use of component angles	367 Application to the rectifier of the Coast and
367 Application to the rectifier of the Coast and	Geodetic Survey
37 Horizontal and oblique photographs	224
371 The horizontal photograph	372 Curvature and refraction
372 Curvature and refraction	373 The high oblique
373 The high oblique	photograph
374 The low oblique photograph	375 The perspective (Canadian) grid

#### CHAPTER 4—RADIAL-PLOT PROCEDURES

41 General procedures	254
411 Preparation of office photographs	412 Determination of the average scale of photo-
412 Determination of the average scale of photo-	graphs
413 Projection and grid construction	414 Control station data
414 Control station data	415 Plot-
415 Plot-	ting control stations on map manuscripts
416 Plotting control on base grids or base	projections
42 Radial-plot assembly of nine-lens photographs with hand templets	281
421 Displacements and distortions on photographs affecting the assembly of radial plots	
422 Pass points on nine-lens photographs	423 Azimuth lines on nine-lens photographs
423 Azimuth lines on nine-lens photographs	424 Hand templets for nine-lens photographs
424 Hand templets for nine-lens photographs	425 Assembling the radial plot with
425 Assembling the radial plot with	hand templets
43 Radial-plot assembly of single-lens photographs with hand templets	296
431 Correction for paper distortion of single-lens photographs	
44 Radial-plot assembly of single-lens photographs with mechanical templets	298
441 Spider-templet method	442 Slotted templet method
45 Direct radial plotting	306
46 Radial-plot completion	307
461 Identifying photo (topo) points and photo-hydro points on photographs	462 Mark-
462 Mark-	ing detail points on photographs
463 Locating points on map manuscripts	464 Estab-
464 Estab-	lishing photogrammetric points for mapping with the Reading Plotter

#### CHAPTER 5—MAP MANUSCRIPT DELINEATION

51 Character of the drafting	316
511 Use of instruments	512 Inks
512 Inks	513 Lettering
513 Lettering	514 Symbols and abbreviations
52 Photograph interpretation	320
521 Field inspection for interpretation of photographs	522 Stereoscopic observation of
522 Stereoscopic observation of	aerial photographs
523 Characteristics of photographic detail	
53 Orientation and adjustment for delineation	326
531 Manual orientation and adjustment	532 Mechanical orientation and adjustment
54 Delineation of map manuscripts	329
541 General statement	542 Delineation of alongshore areas
542 Delineation of alongshore areas	543 Delineation of phys-
543 Delineation of phys-	ical features
544 Delineation of cultural features	545 Delineation of boundaries
545 Delineation of boundaries	546 Delineation of control
546 Delineation of control	547 Tide corrections
547 Tide corrections	548 Preparation of manuscript for
548 Preparation of manuscript for	filing
55 Three-point sextant fixes	400
551 General information	552 Plotting three point fix positions
56 Scaling of positions	402
561 Scales	562 Correction for scale error of the projection
57 Discrepancy overlay	404
571 Preparation of the discrepancy overlay	572 Discrepancies on shoreline manuscripts
58 Photogrammetric office review of the map manuscript and its associated data	405
581 Review of the map manuscript	582 Review of the discrepancy overlay
582 Review of the discrepancy overlay	583 Review
583 Review	of the reports and records
59 Map manuscript completion	411
591 The procedures of map manuscript compilation	

CHAPTER 6—STEREOSCOPIC PLOTTING INSTRUMENTS

	Page
61 Resume of current instruments	442
62 The nine-lens method	445
621 The nine-lens aerial camera	622
624 The Reading Plotters	623
63 The multiplex projector	461
631 Control for multiplex mapping	632
632 Manuscript assembly from multiplex compilations	632
64 The stereoplanigraph	466

CHAPTER 7—RECORDS AND REPORTS

71 Records and reports for photogrammetric mapping	470
711 Control records and reports	712
712 Photographs	713
713 Nautical chart data	714
714 Special reports	715
715 Map manuscripts and accompanying data	716
716 Cost and progress reports	717
717 Statistical data	718
718 Season's report	718
72 The Descriptive Report	479
721 Sequence of contents	722
722 Cover Form 504	723
723 Data Record, Form T-1	724
724 Field-inspection report	725
725 Photogrammetric-plot report	726
726 Compilation report	727
727 Field-edit report	727

CHAPTER 8—WASHINGTON OFFICE REVIEW  
and  
COMPLETION

81 General statement	497
811 Outline of procedures	497
82 Routing and disposal of photogrammetric records	498
821 Preliminary	822
822 Division files	823
823 Photogrammetric records	823
83 Office inspection	504
84 Washington Office review	505
841 General statement	842
842 Map manuscript and descriptive report study	843
843 Cartographic comparison	844
844 Preparation for smooth drafting	845
845 Geographic names	846
846 Hydrography	847
847 Review report and registration	847
85 Smooth drafting and publication	512
851 General statement	852
852 Preparation of reproduction copy	853
853 Planimetric maps	854
854 Shoreline surveys	855
855 Topographic maps	856
856 Verification of drafting	857
857 Proof edit	857
86 Project completion	515
87 Records of published maps	515
871 Record of published maps	872
872 Standards	873
873 Map indexes	873
88 Map revision	517
881 General statement	882
882 Revisions of limited extent	883
883 Extensive revisions of standard accuracy	884
884 Extensive revisions of less than standard accuracy	885
885 New map manuscripts of less than standard accuracy	885

CHAPTER 9—MISCELLANEOUS

91 Coordination of photogrammetric and hydrographic surveys	519
911 General statement	912
912 Advantages and limitations	913
913 Procedures	914
914 Photohydro stations	915
915 Alongshore and offshore features	915
92 Trimetrogon mapping	526
921 The Wilson photoalidade	922
922 Sketchmasters	923
923 The rectoblique plotter	923
93 The Schneider stereoscope	534
94 Reference books	535
941 Ground surveys	942
942 Photogrammetry	943
943 Cartography	944
944 Miscellaneous	944

## ILLUSTRATIONS

Figure	Page
11 Organization chart of a large photogrammetric office	6
12 Drafting instruments	16
13 Metric scale	19
14 Foot scale	19
15 Latitude and longitude scale	20
16 Beam compass in use	21
17 Plywood drawing board	22
18 Utility table for field office use	23
19 Photograph rack	24
110 Plotting table	25
111 Ratio reflecting projector	26
112 Lens stereoscope	27
113 Mirror stereoscope	28
114 Principle of mirror stereoscope	28
115 Prism stereoscope	29
116 F 71 Fairchild stereoscope	30
117 Planimetric map layout	38
118 Graphic project index	40
119 Key to data stamped on single-lens aerial photographs	46
120 Field photograph chart	48
121 Field data stamp	49
122 Bridging with cross flights to control intermediate multiplex strips	55
21 Weather map	60
22 K-17 camera with 12-inch lens	63
23 Fairchild cartographic camera	64
24 Inner cone of cartographic camera	65
25 K-20 camera	66
26 Nine-lens camera	68
27 Diagram of the nine lens camera	70
28 Nine-lens negative	71
29 Spectral distribution of daylight	75
210 U S Coast Guard PB-1G airplane No 77254	78
211 Duration of minimum solar altitude	91
31 Refraction of a ray of light	101
32 Image formation with a simple lens	102
33 The perspective relation of the various forms of a photograph	109
34 Acceptable arrangement of points for determining the approximate scale of a photograph	111
35 Nomograph for determining photograph scale from a map	112
36 The magnitude and direction of relief displacement	115
37 The usual overlapping arrangement of aerial photographs	122
38 The principle of graphic resection as used in radial plotting	128
39 The principle of graphic intersection as used in radial plotting	129
310 The principle of absolute stereoscopic parallax	132
311 How difference in parallax can be measured with dividers	134
312 The relation of parallax difference to relief displacement	136
313 Horizontal cross section of the right eye	140

Figure	Page
3 14 Principle of stereoscopic photographs	143
3 15 Taking condition and also the 'ideal condition' for viewing	144
3 16 Deformation caused by a shortened eye base	145
3 17 Deformation caused by an increase in viewing distance	146
3 18 Deformation caused by a lateral movement of the eyes	147
3 19 Deformation caused by a separation of photographs	148
3 20 Effect of eye base not being parallel to azimuth line	149
3 21 Condition in taking equally tilted photographs	149
3 22 Deformation caused by equal tilt or by unequal flying height	149
3 23 Deformation caused by unequal tilt	150
3 24 Stereograms	153
3 25 Stereogram made from a pair of aerial photographs	154
3 26 The principle of the "floating mark"	156
3 27 Stereogram showing "floating marks"	156
3 28 Nomenclature of the near-vertical photograph	158
3 29 Geometry of the near-vertical photograph	159
3 30 The inclination of any line	162
3 31 The amount of tilt displacement	165
3 32 Effect of tilt and relief on radial lines	168
3 33 Example of combined tilt and relief displacements	169
3 34 The scale at any image	170
3 35 Scale point construction	172
3 36 Analytic geometry of the tilted photograph	175
3 37 Coordinate transformation	177
3 38 Nadir point relations	180
3 39 Solid analytic geometry of the aerial photograph	184
3 40 Sketch showing typical displacement pattern due to tilt, scale and moderate relief	190
3 41 Example of scale point method of tilt determination	193
3 42 Elements of rectification	200
3 43 The Schemppflug condition	202
3 44 The focal length of a rectifier lens	203
3 45 The parallelogram principle	205
3 46 Theoretical and practical rectification	206
3 47 Constants of the transforming printer	212
3 48 Gumbal mechanism of the rectifier of the Coast and Geodetic Survey	214
3 49 Relations of component tilt angles	214
3 50 Relief displacement computer	217
3 51 Graph of the lens settings	220
3 52 Graph of the linear settings of easel	220
3 53 Graph of the angular settings	221
3 54 Graph of corrections to the Y-settings	222
3 55 Nomogram for determining the position of the nadir point after rectification	223
3 56 The Wilson photoalidade	225
3 57 Geometry of the horizontal photograph	226
3 58 Graphic determination of horizontal and vertical angles to an object using a horizontal photograph	227
3 59 Graphic determination of elevation difference	228
3 60 Geometry of the high oblique photograph	238

Figure	Page	
3 61	Horizontal and vertical angles from an oblique photograph	240
3 62	Horizontal angle from an oblique photograph	241
3 63	Vertical angle from an oblique photograph	244
3 64	Adjustment of the horizon line	247
3 65	Construction of the perspective grid	250
3 66	Theory of the perspective grid	252
4 1	A nine-lens photograph	255
4 2	Identification cards for a triangulation station and a substitute station	259
4 3	Preliminary plot for determining average scale of photographs	263
4 4a	The projection and the grids on a map manuscript	271
4 4b	Full size detail of the projection and the grids on a map manuscript	272
4 5	Form M-2388-12, Control Station Data	273
4 6	Plotting by <i>dms</i> and <i>dps</i>	277
4 7	Graph for determining the distance from the principal point to the midpoint	283
4 8	The distribution of pass points for the radial plot assembly of a single flight strip of nine-lens photographs	285
4 9	The distribution of pass points on two nine-lens photographs in a flight strip for an areal plot	285
4 10	Carrying azimuths forward with substitute centers pricked in the direction of the azimuths	286
4 11	Carrying azimuths forward with substitute centers normal to the azimuths	286
4 12	Calibration templet	287
4 13	Plotting templet	288
4 14	Final radial-plot assembly for a map manuscript	294
4 15	Map manuscript with pass points and radial centers	295
4 16a	Master templet—camera "O"	297
4 16b	Master templet—ratio prints only	297
4 17	Spider-templet parts and the tools for their assembly	300
4 18	Assembled spider templet	301
4 19	Radial-plot assembly with spider templets	302
4 20	A slotted templet	304
4 21	Radial-plot assembly with slotted templets	306
4 22	The selection of detail points	312
5 1	Coast and Geodetic Survey freehand lettering for use on map manuscripts	319
5 2	The correct and incorrect shadow orientation of a pair of photographs	321
5 3	Manual orientation and adjustment for delineation	327
5 4	Orientation of lettering	336
5 5	Placement of lettering	337
5 6a	Alongshore physical features on a shoreline manuscript	340
5 6b	Alongshore physical features on a planimetric or topographic manuscript	341
5 7	Planes of reference for rocks	346
5 8	Hachures	362
5 9	Displacement of a building along a road	373
5 10	The subdivision of 24-mile tracts into townships	383
5 10a	Diagram of a township illustrating the method of numbering sections	383
5 11	An original corner	388
5 12	An accepted corner	388
5 13	Township and range designations	390
5 14	A monumented bench mark	395



Figure	Page
5 15 A monumented vertical angle bench mark	395
5 16 A non-monumented bench mark	396
5 17 Tidal bench marks	396
5 18 Form M-2617-12, Tide Computation	398
5 19 The Sular-Lockerbie scale	403
5 20 Form T-2, photogrammetric office review	406
5 21 Symbols and abbreviations	414
5 22 Symbols and abbreviations	415
5 23 Symbols and abbreviations	416
5 24 Symbols and abbreviations	417
5 25 Symbols and abbreviations	418
5 26 Symbols and abbreviations	419
5 27 Symbols and abbreviations	420
5 28 Symbols and abbreviations	421
5 29 Symbols and abbreviations	422
5 30 Symbols and abbreviations	423
5 31 Symbols and abbreviations	424
5 32 Symbols and abbreviations	425
5 33 Symbols and abbreviations	426
5 34 Symbols and abbreviations	427
5 35 Symbols and abbreviations	428
5 36 Symbols and abbreviations	429
5 37 Symbols and abbreviations	430
5 38 Symbols and abbreviations	431
5 39 Symbols and abbreviations	432
5 40 Symbols and abbreviations	433
5 41 Symbols and abbreviations	434
5 42 Symbols and abbreviations	435
5 43 Symbols and abbreviations	436
5 44 Symbols and abbreviations	437
5 45 Symbols and abbreviations	438
5 46 Symbols and abbreviations	439
5 47 Symbols and abbreviations	440
5 48 Lettering and symbol guide	441
6 1 Diagram of the transforming printer	447
6 2 The rectifying camera	450
6 3 Reading Plotter, Model A	452
6 4 Elevation-parallax generator mechanism	454
6 5 The stereoscope-pantograph mechanism	454
6 6 Reading Plotter, Model B	456
6 7 Multiplex apparatus	462
6 8 Stereoplanigraph	467
7 1 Form 504 Descriptive Report Cover	483
7 2 Form T-1, Data Record	485
9 1 Relative arrangement of trimetrogon cameras	526
9 2 Relative arrangement of trimetrogon photographs	527
9 3 Utilized coverage of trimetrogon photographs	527
9 4 Principle of a sketchmaster	530

Figure		Page
95	Vertical sketchmaster	531
96	Oblique sketchmaster	532
97	The rectoblique plotter	533
98	The Schneider stereoscope	534

## T A B L E S

Table		Page
11	Relative map scales	3
12	Steel pen points	17
13	Chronological outline of field party and photogrammetric office operations for photogrammetric mapping	36
14	Classification of control	51
21	Nine-lens camera data	67
22	Nine lens photograph coverage data	67
23	Pressure-altitude equivalents	83
31	Elevation corrections for curvature and refraction	235
32	Elevation corrections for curvature and refraction	235
33	The dip of the apparent horizon	236
34	Depression of the shoreline at different distances from the camera	237
41	Scale factors	265
42	Projection and grid-line intervals	270
43	Tolerable combinations of tilt with relief and scale	282
51	Tolerance equivalents	331
71	Records and Reports	471

# Topographic Manual

## PART II

---

### CHAPTER 1 PRELIMINARY OFFICE PROCEDURES

#### 11 GENERAL STATEMENT

Long before the development of the airplane made it practicable to obtain suitable aerial photographs, a highly efficient system of combined operations for coastal surveys had been evolved in which the planetable furnished the positions of alongshore hydrographic signals as well as large-scale surveys of the shoreline and the adjacent topography needed on the nautical charts

In 1891, R. M. Bache, an officer of the Coast and Geodetic Survey, advocated the use of a captive balloon for photographic surveys of the coast. His recommendation was justly rejected by a committee appointed to study it, because the cost of taking the photographs and reducing them to maps would have been considerably greater than the efficient planetable methods then used.

Officers of the Coast and Geodetic Survey did use terrestrial photographic survey methods with success on the Alaska-Canada boundary surveys in 1894. These methods proved of great value in the mountainous area where weather limited the field season.

The use of aerial photographs in map revision in World War I was followed with much interest, and in 1918-19 a study was made of photographs of Atlantic City, New Jersey, taken by the Army Air Service. From these studies it was concluded that the photographs would require rectification or restitution based on a dense ground control in order to meet the accuracy requirements of the Coast and Geodetic Survey, but that the photographs would be very valuable for areas of much detail, such as cities and harbors and for revision surveys. Later in 1919, the Navy, at the request of this Bureau, took experimental photographs of the waters adjacent to Key West, Florida, with the hope that coral heads, shoals, and dangers to navigation would be visible on them, and could, perhaps, be located through their use. Although some of the shoals were visible on the photographs, others were not. It was concluded that photographs could not be depended on for this purpose, except in very shallow waters.

In 1920, a strip of photographs of the New Jersey coast from Cape May to Sandy Hook was taken by the Army Air Service. These photographs were used with marked economy and efficiency in revising the 1:80,000-scale coast charts. The chart of Annapolis, Maryland, also, was revised from photographs taken by the Naval Air Service.

The Navy photographed the Mississippi Delta for the Coast and Geodetic Survey in 1921-22. The resulting maps were much more complete and satisfactory than could have been made by ground surveys without exorbitant cost. This project is described in Special Publication No. 105, Aerial Survey of the Mississippi Delta.

In 1925, the Navy also photographed the shoreline of Lake Okeechobee, Florida. This project was satisfactorily completed, but, because of difficulties in scheduling the photography with the ground surveys, did not prove economical as a combined-operations project.

The Army Air Corps in 1927-28 photographed the east coast of Florida and the Ten Thousand Islands on the southwest coast of Florida, using three-lens and four-lens cameras. Planimetric maps, compiled from these photographs by radial-line methods, were reproduced by photolithography. This proved so efficient and satisfactory that air photographic surveying operations have been continuous since then.

Experimental surveys indicated that multi-lens cameras would meet the exacting standards of accuracy required for coastal surveys with considerably less control than single-lens cameras. A nine-lens camera, specially designed for Coast and Geodetic Survey requirements by O. S. Reading, was built by the Fairchild Aerial Camera Corporation in 1935. A rectifying camera and the Reading Plotter for the nine-lens photographs have been built since then. The Coast and Geodetic Survey is also using a precision wide-angle single-lens camera and multiplex plotting equipment. Comparative surveys with both types of equipment are now in progress.

The following maps and charts are produced by the Coast and Geodetic Survey in their entirety, or in part, from single-lens and multi-lens aerial photographs: (a) planimetric and (b) topographic maps, (c) airport obstruction plans, and (d) aeronautical instrument approach and landing charts. Aerial photographs are also used for the periodic revision of nautical and aeronautical charts and for triangulation reconnaissance.

Aerial photographs are used by the Government and private industry as a basis for the construction of many special-purpose maps, such as those for the assessment of county and city taxes, for soil conservation and crop rotation, for transcontinental and local highway planning, for transcontinental pipe, telephone, and power line layouts, for timber inventory, for geological purposes, for war needs, and for various types of reconnaissance.

## 12 REQUIREMENTS FOR MAP ACCURACY

Certain standards of map accuracy have been established for maps published by agencies of the Federal Government. These standards of accuracy have been prepared by representatives of the various departments and approved by the Chief Examiner, Surveying and Mapping, Bureau of the Budget. It is required by the Coast and Geodetic Survey that topographic maps, planimetric maps, and shoreline surveys produced by it meet these standards.

In addition to the National Standards of Map Accuracy, the Coast and Geodetic Survey has established its own requirements for the *horizontal* accuracy of topographic maps, planimetric maps, and shoreline surveys as regards alongshore features.

### 121 NATIONAL STANDARDS OF MAP ACCURACY

1. *Horizontal accuracy*—For maps published at scales larger than 1:20,000, not more than 10 percent of the points tested shall be in error by more than 1/30 inch, measured at the publication scale, for maps published at scales of 1:20,000 or smaller, this tolerance is 1/50 inch. (See table 1.1.) These limits of accuracy shall apply in all cases to positions of *well-defined* points only. Well-defined points are those that are easily visible or recoverable on the ground, as the following monuments or markers, such as bench marks and

TABLE 11—Relative map scales

	<i>Publication scale larger than 1 20,000</i>	<i>Publication scale 1 20,000 and smaller</i>
<i>Prescribed accuracy</i>	1/30"	1/50"

<i>Manuscript scale</i>	<i>Publication scale</i>		
	1 10,000	1 12,000	1 15,000
1 5,000	1/15" = 0 0667" = 1 69 mm	2/25" = 0 08" = 2 03 mm	1/10" = 0 1" = 2 54 mm
1 8 500	0 0392" = 0 996 mm	0 047" = 1 194 mm	0 0588" = 1 49 mm
1 10 000	1/30" = 0 0333" = 0 84 mm	1/25" = 0 04" = 1 02 mm	1/20" = 0 05" = 1 27 mm

<i>Manuscript scale</i>	<i>Publication scale</i>			
	1 20,000	1 24,000	1 31 680	1 62,500
1 5,000	2/25" = 0 08" = 2 03 mm			
1 8,500	0 047" = 1 194 mm	0 0564" = 1 43 mm	0 0745" = 1 89 mm	0 147" = 3 73 mm
1 10 000	1/25" = 0 04" = 1 02 mm	0 048" = 1 22 mm	0 0634" = 1 61 mm	0 125" = 3 18 mm
1 20,000	1/50" = 0 02" = 0 51 mm	0 024" = 0 61 mm	0 0317" = 0 81 mm	0 0625" = 1 59 mm
1 24,000		0 02" = 0 51 mm	0 0264" = 0 67 mm	0 052" = 1 32 mm

property boundary monuments, intersections of roads, railroads, etc., corners of large buildings or structures (or center points of small buildings), etc. In general what is well-defined is also determined by what can be plotted at the scale of the map within 1/100 inch. Thus while the intersection of two road or property lines meeting at right angles would come within a sensible interpretation, identification of the intersection of such lines meeting at an acute angle would obviously not be practicable within 1/100 inch. Similarly, features not identifiable on the ground within these limits are not to be considered as test points within the limits quoted, even though their positions may be scaled closely upon the map. In this class would be included timber lines, soil boundaries, etc.

2 *Vertical accuracy*, as applied to contour maps at all publication scales, shall be such that not more than 10 percent of the elevations tested shall be in error more than one-half the contour interval. In checking elevations taken from the map, the apparent vertical error may be decreased by assuming a horizontal displacement within the permissible horizontal error for a map of that scale.

3 The accuracy of any map may be tested by comparing the positions or elevations of points on it with corresponding positions or elevations determined by a survey of higher accuracy. Tests shall be made by the producing agency, which shall also determine which of its maps are to be tested and the extent of such testing.

4 Published maps meeting these accuracy requirements shall note this fact in their legends as follows: "This map complies with the National Standards of Map Accuracy requirements."

5 Published maps whose errors exceed those aforesaid shall omit from their legends all mention of standard accuracy.

6 When a published map is a considerable enlargement of a map drawing (manuscript) or of a published map, that fact shall be stated in the legend, for example, "This map is an enlargement of a 1:20,000-scale map drawing," or "This map is an enlargement of a 1:24,000-scale published map."

7 To facilitate ready interchange and use of basic information for map construction among all Federal map making agencies, manuscript maps and published maps, wherever economically feasible and consistent with the uses to which the map is to be put, shall conform to latitude and longitude boundaries, being 15 minutes of latitude and longitude, or 7½ minutes, or 3¾ minutes in size.

## 122 COAST AND GEODETIC SURVEY MAP ACCURACY

All photo (topo) stations, including landmarks, fixed aids to navigation, etc., shall be located within 0.3 mm (0.01 inch) of the correct geographic position as *measured on the manuscript*. All photo-hydro stations and well-defined points of detail shall be located within 0.5 mm (0.02 inch) of the correct geographic position as *measured on the manuscript*. Well-defined points are those which are easily visible or recoverable on the ground, and shall include parts of features, such as corners of piers, pinnacle rocks, etc.

In the special case where multiplex compilation is at some scale larger than 1:10,000 for reduction to a 1:10,000-scale manuscript, the final manuscript scale shall control the accuracy specifications. Where a manuscript is compiled at 1:10,000 to furnish shoreline features at 1:10,000 and is compiled for further reductions to furnish topographic features at a scale smaller than 1:10,000, the accuracy specifications for alongshore features shall apply at the larger scale, that is, 1:10,000.

Horizontal accuracy requirements for interior features on planimetric manuscripts, topographic manuscripts, and shoreline surveys shall conform to the National Standards of Map Accuracy. In this case, the accuracy requirements refer to the published scale and not the manuscript scale.

No point shall be more than 20 mm (0.075 inch) from its true geographic position.

The vertical accuracy of topographic maps, planimetric maps, and shoreline surveys as regards alongshore features, i.e., heights of rocks, bridge clearances, etc., is that the heights of rocks shall be correct to the nearest foot, local conditions permitting, and that clearances of bridges up to 50 feet shall be correct within 1 foot or within two percent for clearances greater than 50 feet.

Vertical accuracy as applied to land elevations and contouring shall conform to the National Standards of Map Accuracy.

### 13 OUTLINE OF OPERATIONS

Field offices where topographic and planimetric maps are compiled from aerial photographs by graphic methods or on stereoscopic instruments, using the results of photogrammetric field surveys, are called photogrammetric field offices. In this manual they are termed simply photogrammetric offices. The person in charge of such an office is the Officer-in-Charge.

Photogrammetric field surveys include all the field operations necessary for the production of topographic and planimetric maps, among which are the horizontal and vertical control surveys, field inspection of aerial photographs, and field edit after compilation. In this manual parties making such field surveys are referred to simply as field parties, and the offices of such field parties are called field offices. The person in charge of a field party is the Chief of Party. The subparties, each of which is composed of several surveying units, are supervised and their work is coordinated by the field supervisor. A subparty chief is in charge of each subparty, and a unit chief is in charge of each surveying unit.

The operations performed at a photogrammetric office vary with the permanence and the size of the office, but are the same for similar methods of compilation.

Permanent photogrammetric offices are staffed and equipped to handle the office compilation of any assigned project.

Temporary photogrammetric offices are often organized for one definite project, and are staffed and equipped with a view to the completion of that project within an estimated period. These temporary photogrammetric offices are often combined field and photogrammetric offices in that both the field surveys and the office compilation are done by one party.

Whatever the party organization is, close coordination of field surveys and office compilation is essential.

#### 131 PHOTGRAMMETRIC OFFICE ORGANIZATION

The organization of photogrammetric offices cannot be standardized because of varying conditions, but experience has proved some general features of organization to be very advantageous.

In small photogrammetric offices with not more than 15 employees there should be one supervisor-in-charge to assist the Officer-in-Charge. Besides administering the affairs of such an office, the Officer-in-Charge personally plans and supervises its work. Such small

offices should be staffed with personnel proficient in all phases of office procedure except for the phase dealing with stereoscopic mapping. The importance of individual versatility cannot be overemphasized. To obtain this versatility, the average grade of the employees will tend to be somewhat higher than in larger offices which contain several sections with procedures similar to assembly-line production. This does not imply that employees should review each other's work—on the contrary, the review should be done by the Officer-in-Charge or the supervisor-in-charge, possibly with the assistance of one experienced and competent photogrammetrist.

Figure 11 is an organization chart of a large office. The small volume and uneven flow of data do not warrant separate radial-plot and review sections in a small office.

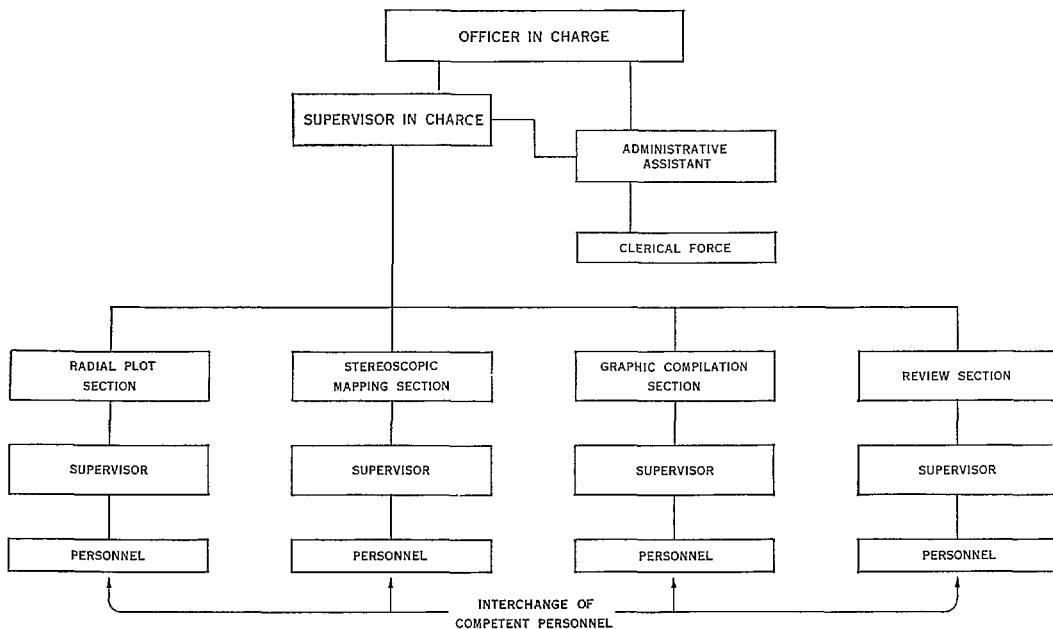

FIGURE 11—Organization chart of a large photogrammetric office

### 1311 *Supervision by the Officer-in-Charge*

The Officer-in-Charge shall supervise and correlate the work of his office. The administration of his office and its coordination with field parties are his full responsibility. By personal inspection he shall assure himself that the sections of his office are performing their operations in accordance with the requirements of the various manuals and the project instructions. Final decisions as to the adequacy of existing control, the location of new control, the limits of the various radial plots, and the selection of the working scale are made by him. Intimate knowledge of the instructions, requirements, and methods are necessary for efficient and harmonious office operations. He should frequently examine all phases of the work of each section, and, if at all practicable, inspect each radial plot and each stereoscopic instrument plot in its final stage. He should be qualified to review the completed map manuscripts, and his partial review of a selected number of them is recommended. He approves a completed map manuscript and its associated data by his signature in the corresponding Descriptive Report.



The Officer-in-Charge should plan the work of the office so that commitments are completed on time, so that all assignments are taken up as soon as the field data are received, so that no partly completed map manuscripts are laid aside, and so that there is a steady flow of results to the Washington Office. All general instructions issued by him should be in writing to avoid confusion and contradictory oral instructions from supervisors.

### *1312 Supervisor-in-Charge*

The supervisor-in-charge is the technical assistant to the Officer-in-Charge. He is responsible for the work and for the assembling of all available control data, prior surveys and local surveys, photographs, diapositives, base grids or projections, map grids or projections, and other information.

With the supervisors of the radial-plot and the stereoscopic mapping sections he shall plan the radial and stereoscopic instrument plots and shall approve their final adjustments. He shall make daily inspections of each section's work and keep himself so informed that he can substitute for any section supervisor without advance notice. Frequent inspections should be made of each employee's work. All incoming and outgoing map manuscripts, reports, and related material shall have his approval.

The successful coordination between field parties and the photogrammetric office depends, to a great extent, on the supervisor-in-charge. He can arrange, or rearrange, office production and procedure to give the greatest possible assistance to the field parties.

### *1313 Administrative Assistant and Clerical Force*

Photogrammetric offices require an administrative assistant who shall relieve the Officer-in-Charge and the supervisor-in-charge of minor administrative matters so that they can devote their full energy to the technical management of the photogrammetric office.

The administrative assistant shall take care of the accounts and routine correspondence, reports and records, shall purchase the supplies, and shall do any other routine duties that may be delegated to him by the Officer-in-Charge or the supervisor-in-charge. Technical reports and records written or compiled by the various sections shall be typed and prepared by him for transmittal to the Washington Office.

Large offices require clerical assistants who have their work assigned and supervised by the administrative assistant.

### *1314 Radial-Plot Section*

The basic accuracy of the map manuscripts produced in a photogrammetric office by graphic methods is the responsibility of the radial-plot section—that is, assuming that the field surveys are complete and accurate within plotting limitations. To attain this accuracy, the radial-plot section must comply with the requirements of this manual, the supervisor must be competent, and the personnel must be trained to do accurate work. The personnel should be experienced compilers or experienced field topographers so that each employee fully realizes and appreciates the importance of this phase of the work. This is definitely not the section for new employees or for those unaccustomed to using photographs in mapping.

When the personnel of this section is insufficient for the work on hand, the most competent personnel should be transferred temporarily from the graphic compilation or

review sections, conversely, the personnel of the radial-plot section should be sufficiently competent so that in slack times they can be transferred temporarily to the graphic compilation or review sections

#### A SUPERVISOR OF RADIAL-PLOT SECTION

The duties and responsibilities of the supervisor of the radial-plot section are as follows

- (a) The basic accuracy of all the products of this section
- (b) The construction and maintenance of indexes of photographs and control
- (c) The study of existing control
- (d) The determination of the scale of the photographs
- (e) All procedures connected with plotting the control on the map projections or grids
- (f) Computations
- (g) The preparation of the required reports
- (h) The availability of controlled map manuscripts when needed for delineation
- (i) The supervision and functioning of this section

The supervisor shall notify the supervisor-in-charge of any additional control requirements, the adequacy and accuracy of related field surveys, the working scale, and the area of radial plots, and shall report any personnel problems that arise

#### B PERSONNEL

The personnel of this section must be thoroughly trained in all phases of photograph preparation and the procedures for laying and adjusting the radial plots, and must be imbued with the requirements for exactness in all phases of the work. In addition, they must have at least a general understanding of photogrammetric field surveys and a thorough knowledge of compilation. They should be proficient in the use of stereoscopes, accurate and neat in all operations, and have personal pride in the results. They should systematically use the filing systems set up for the numerous control data, field data, and photographs in use, this will avoid data being mislaid and perhaps lost, and will certainly save time.

The many and varied duties of the personnel of this section are as follows

- (a) Sorting, inspecting, and indexing photographs
- (b) Checking the completeness of existing control data
- (c) Indexing control data
- (d) Preparing photographs
- (e) Determining the scale of the photographs
- (f) Constructing map manuscripts after the receipt of the map projections and grids
- (g) Constructing templates
- (h) Laying radial plots
- (i) Transferring photogrammetric points determined by the radial plot
- (j) Locating photo (topo) points, photo-hydro points, and such essential detail points as the supervisor may direct
- (k) Checking the agreement of photogrammetric points on adjoining map manuscripts
- (l) Recording data for Descriptive Reports
- (m) Computing
- (n) Continuous filing of source material

#### *1315 Stereoscopic Mapping Section*

There are several different kinds of stereoscopic mapping instruments used by the Coast and Geodetic Survey for the compilation of maps from aerial photographs

The stereoscopic mapping section compiles maps with one or several different kinds of instruments. The accuracy of mapping with these instruments depends on the kind used, the aerial camera, the character of the photography, the base-altitude ratio, the character of the terrain, the photographic materials, the character of the control, and the ability of the operator.

It is the responsibility of this section to determine the adequacy of the supplied photographic materials and the adequacy of the control, and to ascertain that the personnel are properly trained.

The function of this section is the operation of the instruments assigned for the accurate determination of photogrammetric points, hypsometry, or planimetry from aerial photographs and for the drawing and inking of this information. The extent and detail of this procedure shall be according to the project instructions for either planimetric, topographic, or shoreline manuscripts, and each shall comply with the requirements of this manual for its own kind and scale.

#### A SUPERVISOR OF STEREOSCOPIC MAPPING SECTION

The supervisor of the stereoscopic mapping section directly supervises and assists the personnel in the orientation and adjustment of the photography to the horizontal and vertical control and approves the final adjustment prior to the plotting of photogrammetric points, hypsometry, or planimetry. He is responsible for the mechanical care of the instruments in his section and for the testing and training of adaptable personnel to operate these instruments, to interpret photographs, and to complete the map manuscripts or required photogrammetric information. It is his responsibility to see that these operations are carried out according to the project instructions and the requirements of this manual.

#### B PERSONNEL

The personnel in this section operate the stereoscopic mapping instruments and therefore must have good stereoscopic vision. Personnel of other sections with satisfactory stereoscopic vision should be given the opportunity to train to become operators of these instruments. They must develop acute stereoscopic vision and be able to apply this to the accurate determination of elevation differences from photographs. These operators must be proficient in photograph interpretation and map delineation, accurate in all operations, and familiar with the project instructions, and should be familiar with the special needs and practices of the Coast and Geodetic Survey regarding shoreline, hydrographic, and aeronautical details.

The many duties of the personnel of this section pertaining to stereoscopic mapping instruments are as follows:

- (a) All procedures connected with the construction of quadrangle manuscripts including the plotting of control after the receipt of the projections from the Washington Office
- (b) All procedures connected with the transfer of control to the instrument sheets
- (c) The mechanical operation of these instruments
- (d) The adjustment and orientation of photographs to the horizontal and vertical control
- (e) The plotting of photogrammetric control
- (f) The drawing of planimetry and hypsometry from photographs
- (g) The assembly and inking on quadrangle manuscripts of the information that has been plotted and drawn
- (h) The upkeep of the indexes within this section

*1316 Graphic Compilation Section*

The accuracy of a completed map manuscript cannot, as a rule, be better than the basic accuracy of the radial plot. In fact, unless the photographs are used with proper care, accuracy, and understanding, this basic accuracy will be reduced. This is not necessarily due to errors or carelessness in delineation, but is often due to the necessity of slightly displacing certain topographic features in order to show them legibly.

The function of this section is the transfer of the selected topographic features and information from the photographs to the map manuscripts. The extent and detail of this procedure shall be according to the project instructions for either planimetric, topographic, or shoreline manuscripts, and each shall comply with the requirements of this manual for its own type and scale.

**A SUPERVISOR OF GRAPHIC COMPILATION SECTION**

The supervisor is responsible for the delineation in his section—for its accuracy, completeness of detail, and symbol usage. By constant supervision he shall assure himself that this delineation complies with project instructions, the special needs and practices of the Bureau, and the requirements of this manual. His other duties are as follows:

- (a) Training new personnel in the geometry of aerial photographs in compiling procedures and in drafting techniques
- (b) Training, advising and assisting personnel in the interpretation of photographs
- (c) Instructing personnel in the particular needs of the Coast and Geodetic Survey regarding the required hydrographic and aeronautical information, nautical and aeronautical chart practices, and shoreline detail
- (d) Training personnel in the importance and use of stereoscopes and the identification and transfer of photo (topo) points, photo-hydro points and detail points
- (e) Training, advising, and assisting in map delineation
- (f) Assigning map manuscripts
- (g) Seeing that field photographs and related data are used to the fullest degree
- (h) Observing that proper notations and discrepancy overlays are kept by each compiler
- (i) Supervising the writing of Descriptive Reports
- (j) Supervising corrections resulting from the review

Since the new personnel of the office are assigned to this section, various problems will arise. Personal knowledge of the competency, attitude, and progress of each compiler will be advantageous to the Officer-in-Charge.

**B PERSONNEL**

The graphic compilation section is composed of employees with varying degrees of experience and training—from new employees who require constant supervision to experienced photogrammetrists who require little supervision. Even experienced draftsmen who have not used permanent plastic ink on plastic sheeting are at first apt to be discouraged, therefore, because drafting is such a necessary and an important step in the compilation of map manuscripts, the compiler must be skilled in the use of small drafting instruments.

Inasmuch as most of the information to be delineated is taken from photographs, it is imperative that the compilers know the characteristics of aerial photographs and become proficient in their interpretation. In order to complete map manuscripts efficiently, the compilers must also be skilled in the use of metal protractors, stereoscopes, projectors, and precision pantographs, must be thoroughly familiar with the project instructions and the

special needs and practices of the Coast and Geodetic Survey regarding shoreline, hydrographic, and aeronautical details, and must know how to delineate accurately

The personnel of this section do the assigned compiling, including topographic, planimetric, and shoreline manuscripts as well as the miscellaneous drafting needed in an office of this type. A discrepancy overlay is kept continuously during the delineation of each map manuscript, and notes are kept on which the written Descriptive Report is based. After each map manuscript and its Descriptive Report have been reviewed, the map manuscript shall be corrected item by item by the original compiler so that he may note and thereafter avoid repeated errors and omissions.

### *1317 Review Section*

Even though supervision and accumulated photogrammetric experience do increase quality, map manuscripts need to be reviewed. The purpose of the review is to ensure that the map manuscript is complete, accurate, neat, legible, and complies with the project instructions and the requirements of this manual—that the discrepancies have been properly noted, and that the Descriptive Report is complete and satisfactorily explains any questionable areas, data, or unusual methods used. After the reviewer has approved the Descriptive Report, the completed map manuscript and all its associated data and reports are ready for the approval of the Officer-in-Charge before being forwarded to the Washington Office.

#### **A SUPERVISOR OF REVIEW SECTION**

The supervisor of the review section is responsible for the review of the map manuscripts and the accompanying reports and data. He should supervise this section so that any criticism resulting from the reviews is made diplomatically, to the end that his section is regarded by the personnel of the stereoscopic mapping and graphic compilation sections as an aid to them through their supervisor. Tactless and unintelligent handling of reviews can cause tension and anxiety among the stereoscopic instrument operators and the compilers.

The supervisor shall have full knowledge of the project instructions, the requirements of this manual, and the special practices of the Coast and Geodetic Survey regarding shoreline, hydrographic, and aeronautical information. Also, he must be intimately familiar with photograph usage and field data. With this knowledge and with judgment in the use of accuracy and reproduction tolerances, he will keep a steady flow of completed map manuscripts on their way to the Washington Office.

#### **B PERSONNEL**

The personnel of the review section should be sufficiently numerous to avoid any accumulation of unreviewed map manuscripts. After a map manuscript has been completed in the stereoscopic mapping section or the graphic compilation section, its review should be taken up and completed without any unnecessary delay. When necessary, competent photogrammetrists from other sections can be temporarily transferred to this section to keep the reviews current.

This personnel shall make an impersonal review of the map manuscripts, the Descriptive Reports, and all accompanying data. A review overlay indicating errors and omissions is to be prepared for each map manuscript.

**132 PHOTOGAMMETRIC OFFICE**

The selection of quarters for a photogrammetric office is important for the morale and efficiency of the employees and the quality of their work. If possible, the office should be located in a federal building, otherwise, rented space is the alternative. In federal buildings janitor service, heat, light, and water are usually furnished. These same accommodations and the required garage space should be included in the lease for any rented quarters, if practicable.

The office should be located in an area free from industrial dirt and smoke, with access to transportation and restaurants. North frontage is the most desirable, as it permits the natural light to penetrate deeply into the rooms without allowing direct sunlight on the drafting tables. There should be no nearby tall buildings to decrease the natural light.

The quarters required for a photogrammetric office are determined by its size and organization. If field surveys are a part of the duties of the organization or if field parties use the quarters, their needs should be considered. It is difficult for them to operate freely from an office located in the heart of a city.

The layout of a photogrammetric office will depend on the available space. The work should be arranged functionally, with the employees of each section grouped together and the several sections organized according to the flow of work. Provision should be made for a dark room, a work shop, a stock room, and administrative offices as are required to meet the needs of the office. Either air conditioning or humidifying equipment to decrease dimensional change in the photographs and the various sheetings is desirable.

The photogrammetric office should have such facilities and be so equipped that the individual employee does not work under strain, thus reducing to a minimum the complaints about the physical plant and its equipment. Every effort should be made to secure adequate ventilation and sanitary drinking and toilet facilities. The quarters must be heated properly by equipment of sufficient capacity. Many man-hours have been lost in "warm" climates because of inadequate heating systems. Drafty buildings of cheap open construction should be avoided. Efficient photogrammetric work cannot be done by employees who are cold or physically uncomfortable. A system of indirect lighting or fluorescent lamps which will eliminate shadows and give near-daylight conditions is needed to supplement natural light on dull gray days and at night. This is important so that work can be continued without interruption during the day or during night shifts, which are sometimes necessary. Any electric company has a specialist who will be glad to aid in solving lighting problems. With modern developments improperly lighted photogrammetric quarters are inexcusable. Because of the amount of electric equipment used, three-phase current should be available. Several electric outlets are necessary for each multiplex unit, and each photogrammetrist needs at least one outlet that can be connected to his table.

Security shall be provided for classified material, such as photographs, plans, and maps. Ample storage space is needed for field instruments, working tools, and equipment connected with the office. Space for the storage of skiffs, outboard motors, small boat equipment, stadia rods, and similar equipment should be on the ground floor.

Since photogrammetric parties cannot operate efficiently without proper transportation for their field and administrative work, garage facilities for the automotive equipment of the office should be an integral part of the quarters. If this is not possible, garage space conveniently located with reference to the office should be obtained—at any rate arrangements should be made so that the equipment is not parked on the street.

## 14 EQUIPMENT AND INSTRUMENTS FOR PHOTOGRAMMETRIC OFFICES

Certain equipment and instruments are necessary and should be on hand for the successful completion of the operations assigned a photogrammetric office. The condition and the adequacy of these instruments should be checked periodically. As types of photography and the methods of making maps from them vary considerably, additional instruments and equipment are required at various times and may be obtained from the Washington Office.

It is the responsibility of the Officer-in-Charge to foresee the requirements of his office and to be certain that the necessary instruments and equipment are available prior to their actual need.

Although photogrammetric offices may not have field parties attached to them, they should have a certain minimum of the instruments and equipment needed for small routine horizontal and vertical control surveys.

### 141 INSTRUMENTS

A photogrammetric office shall have a sufficient number of plotting and drafting instruments for general office use as well as a sufficient supply of small drafting instruments so that the necessary number and types can be issued to each photogrammetrist. The small instruments that are not issued to individuals should be kept in the best possible repair in a locked cabinet. All such instruments should be scrupulously cleaned of rust and corrosion and covered with a light protective film of oil. Instruments for general office use, such as beam compasses, protractors, and lettering sets should be kept in a cabinet that is convenient and available to all employees. One employee should be given the responsibility of their upkeep and care.

The tension in bow-spring or spring-adjusted instruments should be almost completely relieved when the instruments are not in use.

Each photogrammetrist is entrusted with the custody of the instruments issued to him and is responsible for their upkeep.

Detailed descriptions of plotting and drafting instruments and their care and use may be found in section 48, Special Publication No. 143, Hydrographic Manual, or in instrument catalogs. The following is a list of the plotting and the drafting instruments used in the compilation of map manuscripts from aerial photographs.

#### BEAMS, FOR BEAM COMPASSES

9-inch	30-inch
12-inch	40-inch
18 inch	48 inch
24-inch	

#### DIVIDERS

Bow-spring large
<sup>1</sup> Bow-spring small
<sup>1</sup> Hairspring
Proportional
Spacing

#### ERASING MACHINES

#### FIXTURES, FOR BEAM COMPASSES

<sup>1</sup> These instruments are generally issued to each photogrammetrist. However, this specified list should not be held too rigidly as many skilled photogrammetrists can use other instruments to good advantage.

**\* FRENCH CURVES**

Dietzgen No 13  
 Do 18  
 Do 20  
 Keuffel & Esser No 12  
 Do 26

**\* GLASSES**

Engraver's  
 Magnifying  
 Triplet, 10-power

**INSTRUMENTS, DRAWING SET****LETTERING SETS**

Leroy—consisting of the following

Scriber  
 Pen points Nos 00 (fine) through 3 (heavy)  
 Templets Nos 3240-100 CL (small)  
 Do 3240-120 CL  
 Do 3240-140 CL  
 Do 3240-175 CL  
 Do 3240-200 CL  
 Do 3240-240 CL (large)

Wrico—consisting of the following

Pens Nos 2 (heavy) through 7 (fine)  
 Templets Nos VCN 140 SCN 140 (small)  
 Do VCN 175 SCN 175  
 Do VN 240 SN 240  
 Do VN 350 SN 350  
 Do VN 500 SN 500  
 Do VC 240 SC 240  
 Do VC 350 SC 350  
 Do VC 500 SC 500 (large)

**LIGHT TABLES****MAP MEASURES****PANTOGRAPHES****\* PENCILS**

Colored wax—black, yellow, and red  
 Drawing, H through 6H  
 Mechanical—black, red, and blue lead  
 Writing, HB through 3B

**\* PENHOLDERS****\* PEN POINTS****PENS**

Bow-spring  
<sup>1</sup> Contour  
 Double curve  
<sup>1</sup> Drop bow-spring  
 Railroad  
<sup>1</sup> Ruling 4½-inch and 5½-inch

**\* PRICKERS****PROJECTORS, RATIO REFLECTING****PROTRACTORS**

Celluloid circular  
 Celluloid circular, 3-arm  
 Metal, 3-arm

<sup>1</sup> - These instruments are generally issued to each photogrammetrist. However this specified list should not be held to rigidly as many skilled photogrammetrists can use other instruments to good advantage.  
 - The selection of the type and number of these instruments is left to the individual.



## SCALES

- Architect's, 12-inch
- Engineer's, 12-inch
- <sup>1</sup>Foot, 1 10,000 and 1 20,000
- Latitude and longitude
- Lockerbie diagonal, 1 10,000 and 1 20,000
- Meter bar
- <sup>1</sup>Quarter-meter
- Topographic

## SCRAPERS

- <sup>1</sup>Round
- <sup>1</sup>Flat

## STEREOSCOPIES

- Lens
- Mirror
- Prism
- The F 71 Fairchild

## STRAIGHTEDGES

- <sup>1</sup>6-inch
- <sup>2</sup>18-inch
- <sup>2</sup>24-inch
- 48-inch
- 60-inch

## TRIANGLES

- <sup>1</sup>4-inch, 30° by 60°
- <sup>1</sup>4-inch, 45°
- <sup>1</sup>12-inch, 30° by 60°
- <sup>1</sup>12-inch, 45°
- Various other sizes

## DRAFTING MACHINES

The instruments listed above have not been described in detail, but a few brief comments on the care and use of some of them are justifiable

*1411 Drafting Pens*

## A RULING PENS

Practically all the employees in a photogrammetric office use ruling pens to draw straight and curved lines of even weight and thickness. These pens are always guided by the edge of a triangle, straightedge, french curve, or similar instrument. The ruling pens are usually  $4\frac{1}{2}$  or  $5\frac{1}{2}$  inches in length (*F* and *G* in fig 1.2). They are made of excellent quality carbon steel and are of the spring-blade type (one blade springs away from the other when not held closed by a thumbscrew). This type of pen has been found to retain its setting better than the type with one blade hinged.

When used for inking on plastic sheeting with plastic ink, some of these pens leave a small "bead" of ink at the beginning and the end of a line which then has to be scraped to its proper width. This can be remedied by slightly straightening the spring blade to make its convexity approximately that of the straight blade. This brings the ribs of the two blades more nearly parallel, dispersing the same volume of ink over a greater area and thus retarding the flow of ink. The straightening of this blade has to be done with extreme

<sup>1</sup> - These instruments are generally issued to each photogrammetrist. However, this specified list should not be held too rigidly as many skilled photogrammetrists can use other instruments to good advantage.

The selection of the type and number of these instruments is left to the individual.

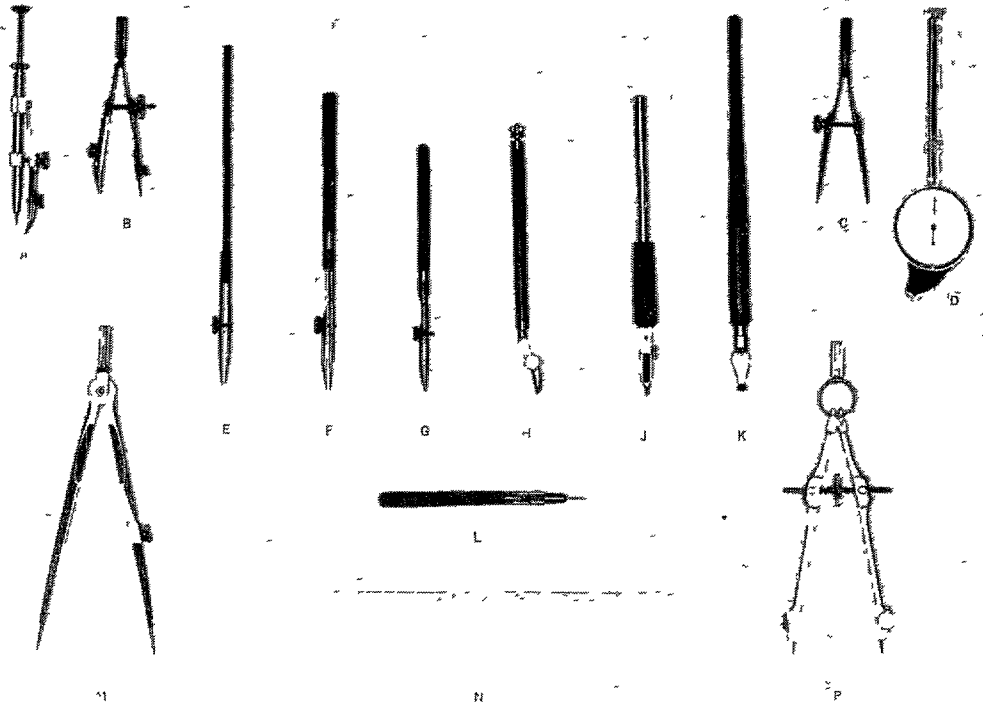

FIGURE 12—Drafting instruments A Drop bow spring pen B Bow spring pen C Bow spring dividers, small D Map measure E, F, and G Ruling pens H Contour pen J Barch Payzant pen K Speedball pen L Pricker M Hair spring dividers N Straightedge P Bow spring dividers, large

care, as the steel is tempered and somewhat brittle and the blade is likely to be broken. As this will lengthen the spring blade a little, the two blades should afterward be evened in length and then sharpened. The blades should not be marred during this straightening. Detail pens are on the market that are similar to *E* in figure 12 with the same taper to each blade. This type pen seldom leaves a bead.

Permanent plastic ink has a very corrosive effect on drafting instruments with which it comes in contact. All types of pens must be cleaned frequently during use and must never be put away without first being cleaned thoroughly, otherwise the ink will corrode them beyond usefulness in a relatively short time.

A ruling pen that has become dull or one whose nibs have become uneven may be sharpened on a fine oilstone if extreme care is used. To restore the nibs to their original parabolic shape or evenness, the blades should be brought into light contact while the pen is held in a vertical plane and whetted with a back-and-forth motion through an angle of about  $120^\circ$ . To sharpen the pen, the outside surface of each nib is held nearly flat on the surface of the oilstone and whetted with a rotary motion to conform to the shape of the nib, care being taken not to alter the parabolic shape of the ends. The edges should not be too sharp or they will cut the sheeting. The bur should be removed from the inside of the blades by using a piece of leather or emery polishing paper.

During the sharpening procedure, the pen should be frequently examined so that the sharpening is stopped when the reflecting or bright spot has vanished from the end or drawing surface. The blades should not be sharp enough to cut plastic sheeting when tested by drawing a line, without ink, across it. If oversharpened, the first operation—that of restoring the nibs to their original parabolic shape—should be repeated. When tested with ink on plastic sheeting, the pen should be capable of drawing clean sharp lines down to a fine hairline. If these fine lines are ragged or broken, the pen is not perfectly sharpened.

Contour, drop bow-spring, bow-spring, double curve, and railroad pens should be similarly sharpened.

Emery polishing paper is also used to polish these and other small metal drafting instruments.

### B CONTOUR PENS

The contour pen (*H* in fig 12) is used to ink wandering curved lines, such as contour lines. In both workmanship and material it is of the same high quality as the ruling pens, can be used very satisfactorily with plastic ink on plastic sheeting, and requires the same scrupulous care.

### C DROP BOW-SPRING PENS OR PENCILS

The drop-spring pen (*A* in fig 12) is the most convenient instrument in the photogrammetric office for drawing small circles for the identification of control and photogrammetric points. One leg holding either a pen or a pencil revolves around the other stationary leg ending in a pointed pin. This pin is placed in the pricked point and the pen or the pencil is lowered onto the drawing surface and then rotated to draw the circle. Circles can be varied in size from almost a dot to 2 centimeters (0.8 inch) in diameter. If the circle is not concentric with the center point, the instrument should be repaired or replaced.

### 1412 Drafting and Lettering Pens

Although individual preferences vary somewhat, an experienced draftsman knows with which make and type of drafting and lettering pens he can obtain the best results. Several types and makes of steel pen points are listed in table 12.

TABLE 12—Steel pen points

Make	All purpose crow quill	Flexible points			Heavy work		Stiff points
	Fine	Fine	Extra fine	Fine	Medium	Extra fine	
Esterbrook	62	354	355	356	357	358	
Gillott	659	291	290	170	303	404	
Hunt	102	103	100	99	22	56	104

Crow-quill penholders, such as Esterbrook No. 32 or L. & C. Hardtmuth Inc. No. 106B, will be required for pen points Nos. 62, 659, 102, and 104. Penholders of medium size, such as Esterbrook No. 35, are used for the other pen points.

For neat freehand lettering some photogrammetrists prefer either a Barch-Payzant or a Speedball pen (*J* and *K* in fig 1 2) These pens give uniformity of line width and density Barch-Payzant pens Nos 5, 6, 7, and 8 are of considerable use in any photogrammetric office The most practicable types of Speedball pens for a photogrammetric office are Nos 2, 3, 4, 5, and 6 in styles A and B With either type of lettering pen, the line width decreases as the number increases

### 1413 Lettering Sets

Two types of mechanical lettering sets, manufactured under the trade names of *Wrico* and *Leroy*, are furnished the photogrammetric offices While they are not generally used in delineating map manuscripts, they are used for titles, progress sketches, and miscellaneous lettering The pens should be thoroughly cleaned immediately after use and before the ink hardens in the small orifices of the pen points Cleaning fluids are manufactured for both types of pens, however, either soapy water or household ammonia is excellent If household ammonia is used, the pens should be rinsed thoroughly with water afterward and dried so that the metal will not corrode

### 1414 Dividers

#### A BOW-SPRING AND HAIRSPRING DIVIDERS

Small bow-spring and hairspring dividers are the two types of ordinary dividers most commonly used in a photogrammetric office Small bow-spring dividers (*C* in fig 1 2) are probably used more often because they are better adapted for measuring the many short distances used in identifying control on photographs They are used to measure distances to approximately 2 centimeters (0.8 inch) These 3½-inch bow-spring dividers are constructed from a single piece of spring steel, except for the threaded spindle, handle, and screws The legs are pointed and are connected by a threaded spindle The thumbscrew on the spindle is used to adjust them to the desired setting As there is considerable spring against the thumbscrew, the legs should be compressed with the fingers while the dividers are being approximately set, this avoids excessive wear on the threads and speeds the operation

For measuring distances from 2 to approximately 15 centimeters, 6-inch hairspring dividers (*M* in fig 1 2) can be used They have two separate legs of stainless steel hinged at the top by a friction pivot joint One leg is fitted with a hairspring and thumbscrew to provide a fine adjustment of approximately 5 millimeters in making final settings These dividers are set at the correct friction by skilled instrument makers, and it is inadvisable for photogrammetrists to attempt adjustment When dividers become loose at the friction joint or otherwise unserviceable, they should be returned to the Washington Office for adjustments or repairs

The points of both the small bow-spring and hairspring dividers should be kept even in length and sharp First they should be made of even length by placing the legs together and lightly grinding them back and forth on an oilstone, while holding the dividers vertically Then each point should be sharpened Bow-spring points are round but hairspring points are circular on the outside and flat on the inside In sharpening the circular points, resulting flat surfaces must be avoided, and the length of the legs should not be shortened These instruments can be preserved in their original condition for a long time by sharpening them periodically on emery polishing paper

Large bow-spring dividers (*P* in fig 12) are useful where the distances are too long to be measured by small bow-spring dividers. Both points are removable. This instrument can be used to measure distances from approximately 1 to 10 centimeters

**B SPACING DIVIDERS**

Spacing dividers are specially constructed with multiple legs so arranged as to subdivide the total distance spanned into a number of equal parts. The size most frequently used is about 6 inches long and contains 11 points consecutively numbered 0 to 10. With these dividers distances up to 9 inches may be divided into 10 equal parts. Where photographs of relatively flat terrain are not at the same scale as the map projection and a projector is not available, these spacing dividers are extremely useful to aid in adjusting the photographs to the map projection.

**C. PROPORTIONAL DIVIDERS**

Proportional dividers are of some use in enlarging or reducing detail between map manuscripts of different scales. They are also of some limited use in transferring changes and additions from large-scale plans to the map manuscripts.

*1415 Scales*

Most scales used by the Coast and Geodetic Survey for constructing projections and for plotting control stations are graduated in the metric system.

The meter bar is a scale 1 meter in length. It is used in constructing projections, in scaling distances, and in other operations involving comparatively long distances. All meter bars now acquired are tested for accuracy and calibrated by the National Bureau of Standards, the allowable error being 0.1 mm for any distance. Those furnished are graduated on one side at a scale of 1:10,000 and on the reverse side at a scale of 1:20,000. This same bar may be used for other scales by applying a simple ratio to the distance to be scaled. For example, a 10,000-meter distance on a 1:40,000-scale map will equal 5,000 meters on the 1:20,000 scale of the meter bar, or similarly, 2,500 meters on the 1:10,000 scale.

The length of a meter bar is divided into equal spaces representing 100 meters each at the scale of the bar. The width of the bar is divided into 10 equal spaces by numbered parallel lines. At the left end of the bar one 100-meter space is subdivided by 10 parallel diagonal lines in such a way that distances to tenths of a meter may be scaled.

Quarter-meter scales (fig 13), similar to the meter bar but only a quarter meter in length, at scales of 1:10,000 and 1:20,000 are used by most employees. These are not

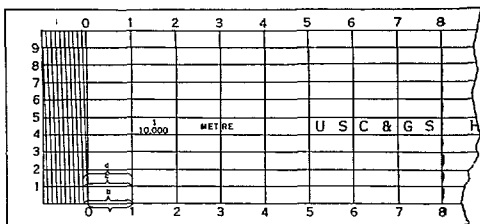

FIGURE 13—Metric scale  $a = 1000$  meters  $b = 1100$  meters  $c = 1110$  meters  $d = 1115$  meters

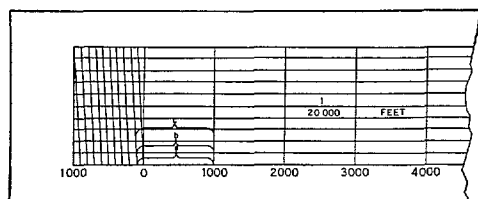

FIGURE 14—Foot scale  $a = 1100$  feet  $b = 1110$  feet  $c = 1125$  feet

tested for accuracy before being issued from the Washington Office and should be compared with a meter bar of known accuracy before use

Foot scales (fig 14) are similar to meter bars in construction, scale, and use but the lengths and the values of the subdivided spaces naturally differ. The smallest direct reading is 10 feet, but one-foot distances can be interpolated between the parallel horizontal lines as illustrated. These scales are used in plotting control points or other data whose coordinates are in feet.

Latitude and longitude scales (fig 15) are similar in appearance to triangular engineer's scales and are constructed so that any one of the three edges may be placed in close contact with the paper. They are designed particularly for use at scales of either 1:10,000 or 1:20,000 for plotting or scaling geographic positions in seconds without having to convert the seconds into meters. Their chief advantage is in plotting and checking positions on sheets that contain some distortion. Each rule contains six scales—one for use in plotting latitude, and five for use in plotting longitude at various latitudes. Each scale is slightly longer than 1 minute of arc at a scale of 1:10,000 and is divided into 60 main divisions, each division being further subdivided into 5 divisions. It is thus possible to plot 0.2 second of arc directly from the divisions and to interpolate to 0.05 second. Small magnifying glasses are provided which can be attached to the scale and slid along the rule to any desired position.

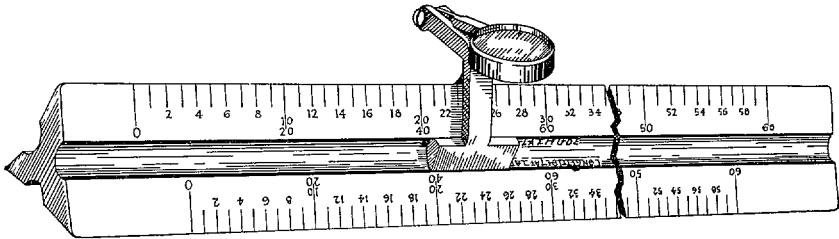

FIGURE 15—Latitude and longitude scale

A topographic scale is similar in appearance to a triangular engineer's scale. It has the following six different scales:

Scales	Smallest direct readings
Meter (1:20,000) -----	100 meters
Centimeter -----	0.05 centimeter
Foot (1:10,000) -----	200 feet
Foot (1:20,000) -----	500 feet
Foot (1:62,500) -----	1000 feet
Inch -----	0.02 inch

The topographic scale is used for general use in photogrammetric offices and is excellent for field use. With it, surveying units are rarely without an appropriate scale for unexpected field needs.

### 1416 Straightedges

Straightedges (*N* in fig 12), usually of stainless steel with one edge beveled, are furnished to photogrammetric offices in various lengths from 6 to 72 inches. Each photogrammetrist needs a 6-inch and an 18- or 24-inch straightedge.

Straightedges should be tested for straightness and examined to ensure that no burs are on them to scratch the object they are used on or to make defects in the lines drawn with them. A defective straightedge shall be returned to the Washington Office.

When not in use long straightedges should be kept in canvas cases or other suitable containers, short straightedges should be wrapped in tissue paper, and all should be stored where they will be protected from moisture. When necessary, they should be cleaned with soap and water or benzine and then thoroughly dried.

#### 1417 Protractors

Circular celluloid and metal three-arm protractors, graduated in degrees, are instruments with which horizontal angles can be plotted or scaled on plane surfaces. These horizontal angles are used in plotting directions and in forming three-point fixes so that positions can be plotted graphically. Protractors and their use are described in detail in subject 453 of Special Publication No. 143, Hydrographic Manual.

#### 1418 Beam Compasses

Beam compasses (fig. 16) are used to measure distances that are too long to be measured accurately with ordinary dividers. They are indispensable in making projections, and positions can usually be plotted more accurately with them than with dividers.

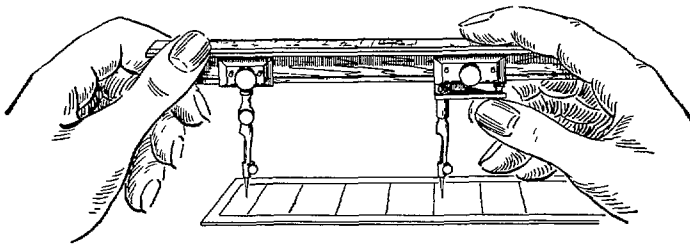

FIGURE 16.—Beam compass in use

The beam compass issued by the Coast and Geodetic Survey consists of a light rigid bar of wood and two compass fixtures which slide on the bar. Each fixture may be clamped at any desired point by means of a thumbscrew on the side of the fixture. One of the fixtures embodies a hairspring device so that minute adjustments can be made parallel to the bar. These bars are obtainable in lengths from 12 to 60 inches in multiples of 6 inches, but in photogrammetric work a 9-inch bar is the most convenient length, the 12-inch bar should be cut to about this length. Needle points are generally used in both fixtures, but a pencil point or ruling pen may be fitted into the socket of either fixture. The points should be kept sharp.

In setting a distance on a beam compass by reference to a metal scale, a light touch and extreme care should be used so as not to deface the graduations of the scale.

1419 Miscellaneous Items

The following miscellaneous items are not considered instruments, but photogrammetrists find continual need and use for them

- <sup>3</sup> Azimuth liners
- Emery polishing paper, grade 4/0
- Erasers, blade knife, rubber, and steel
- Erasing shields
- Hones
- Oilstones, fine
- Paperweights
- Pencil pointers, emery
- Tapes, clear cellulose and drafting
- Thumbtacks

142 FURNITURE

As the types and the quantities of furniture needed in a photogrammetric office vary because of the different conditions under which the work is done, no complete standardized list is applicable. However, regardless of the size or the permanence of the office, the

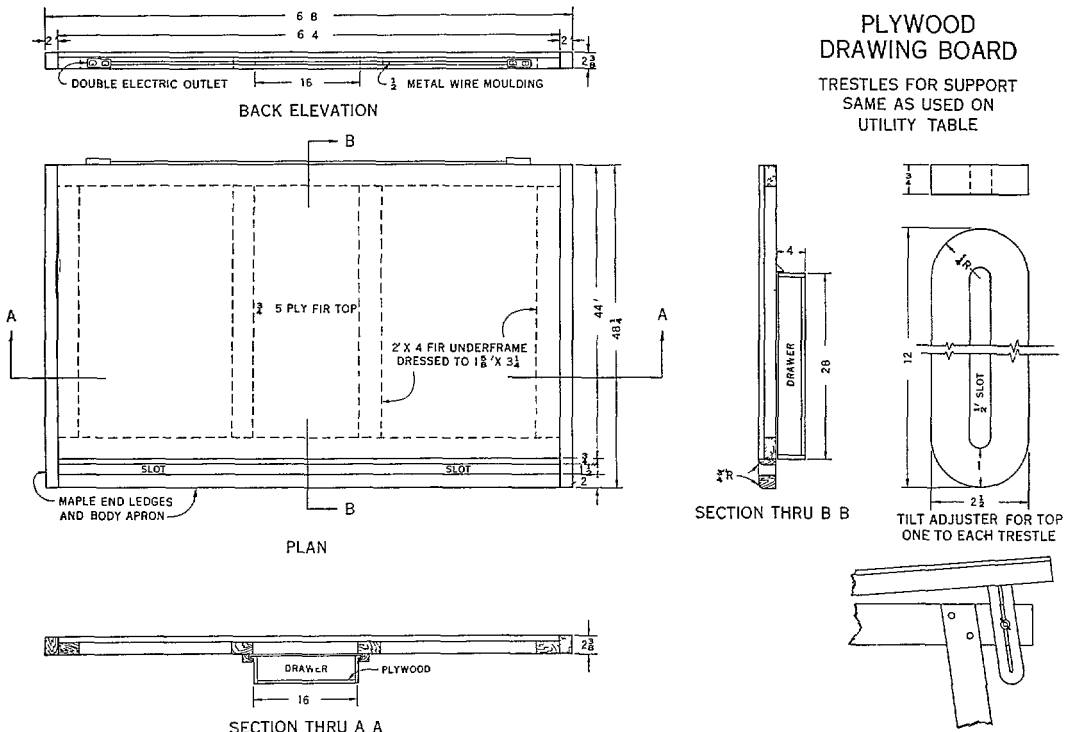

FIGURE 17—Plywood drawing board

<sup>3</sup> An azimuth liner is made of plate glass, lucite, or other similar transparent material that will not easily warp or twist. The material should be approximately 1/10 inch thick, 4 inches wide, and in appropriate lengths according to the method of establishing azimuths and according to the various sizes of photographs. A pin centered about one half inch from one of the ends is driven through the material until it protrudes approximately one twentieth of an inch on the opposite side. A fine straight line is then centrally etched from this point for the entire length of the liner with holes one fifth of an inch in diameter centered at 1 inch intervals on this etched line.



standardization of some types of furniture is advantageous in maintaining a systematic production and high quality output without loss of or damage to essential records or material. Items, such as the radial-plot table, drawing boards, photograph racks, and cabinets, should be kept clean and in such physical condition that photographs and plastic sheeting will not be soiled, torn, or scratched.

1421 *Drawing Boards*

Each photogrammetrist probably has a preference for one particular type of the various drawing boards. Those made of white pine strips are among the best. The strips are glued together and dovetailed maple cleats underneath, normal to the strips, allow the wood to contract or expand.

Another well-liked board is a wooden frame with a plate glass inset for the drawing surface. Such a board has some advantages, but it is comparatively expensive and the plate glass is apt to be broken.

The plywood drawing board shown in figure 17 has been successfully used at photogrammetric offices. It is sturdy, it can be shipped or moved easily, and its surface stays flat. The electric outlets on the back edge of the board are convenient and eliminate many drop or extension cords.

The utility drawing board (fig 18) is especially useful for field parties that move their headquarters frequently. These boards should be sandpapered properly and given several coats of shellac, being lightly rubbed down with very fine sandpaper after each coat.

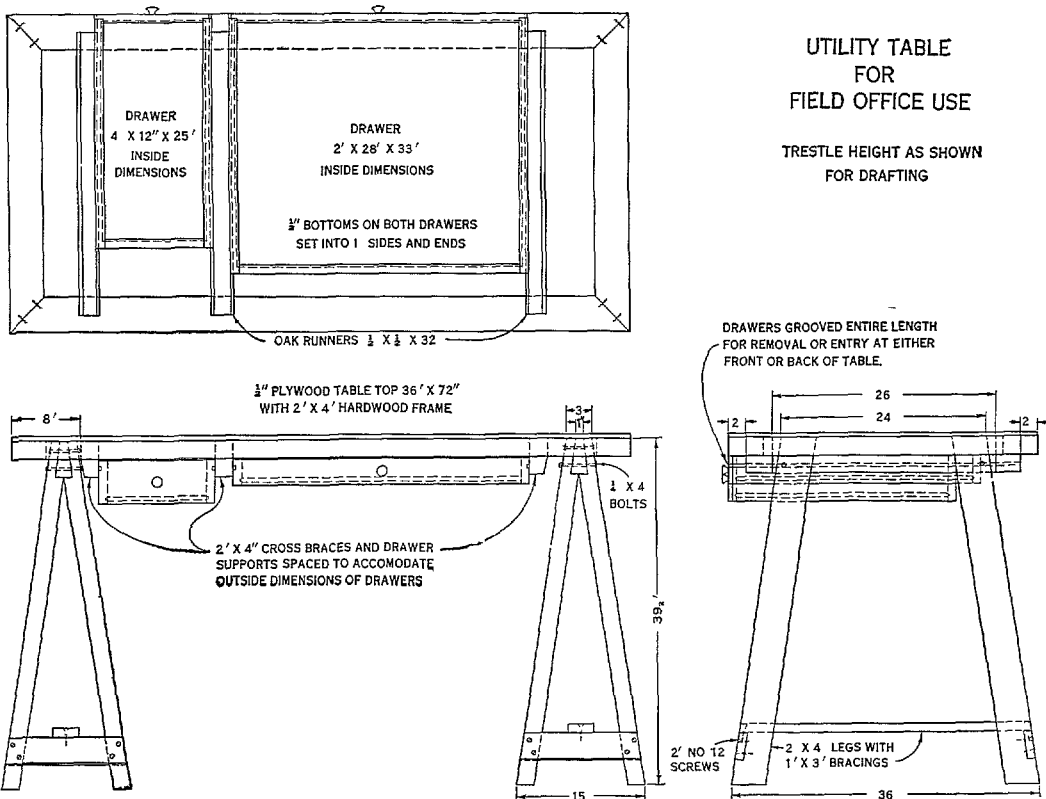

FIGURE 18—Utility table for field office use

1422 *Drafting Lights*

Natural light and artificial overhead or indirect lighting equipment must be supplemented by individual drafting lights. Light-weight adjustable light fixtures using two 15-watt 18-inch fluorescent lamps are excellent. These or similar adequate fixtures are needed to provide each photogrammetrist with proper lighting.

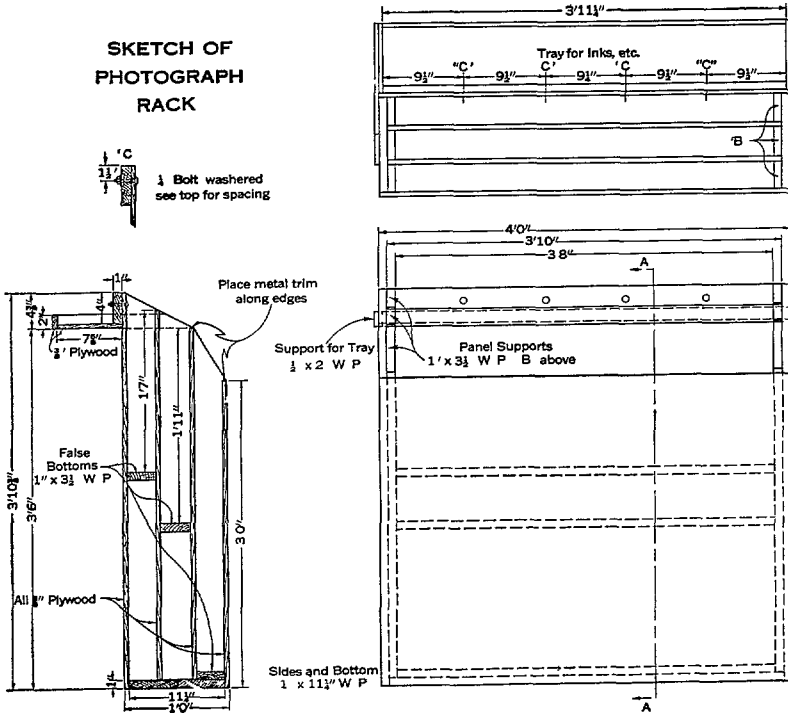

FIGURE 19—Photograph rack

1423 *Photograph Racks*

To ensure that photographs are properly cared for, each photogrammetrist should have a photograph rack. The cost of duplicating one ruined nine-lens photograph alone will pay for this rack. (See fig 19) Here all types of photographs—mounted or unmounted nine-lens, and single-lens of all sizes—plans, maps, and other data can be stored. The rack can be placed either to the right or left of the board, and inks can be kept in the tray so sheets and photographs can be moved freely on the drawing board without risk of upsetting ink bottles.

The photograph rack should be finished in the same way the drawing boards are.

1424 *Radial-Plot Table*

The ordinary drawing board is not large enough or strong enough to accommodate radial plots laid by any of the templet methods.

Some extremely large plots have been laid using base grids on various materials (aluminum, plywood, masonite, and plastics) laid directly on the floor. The result may

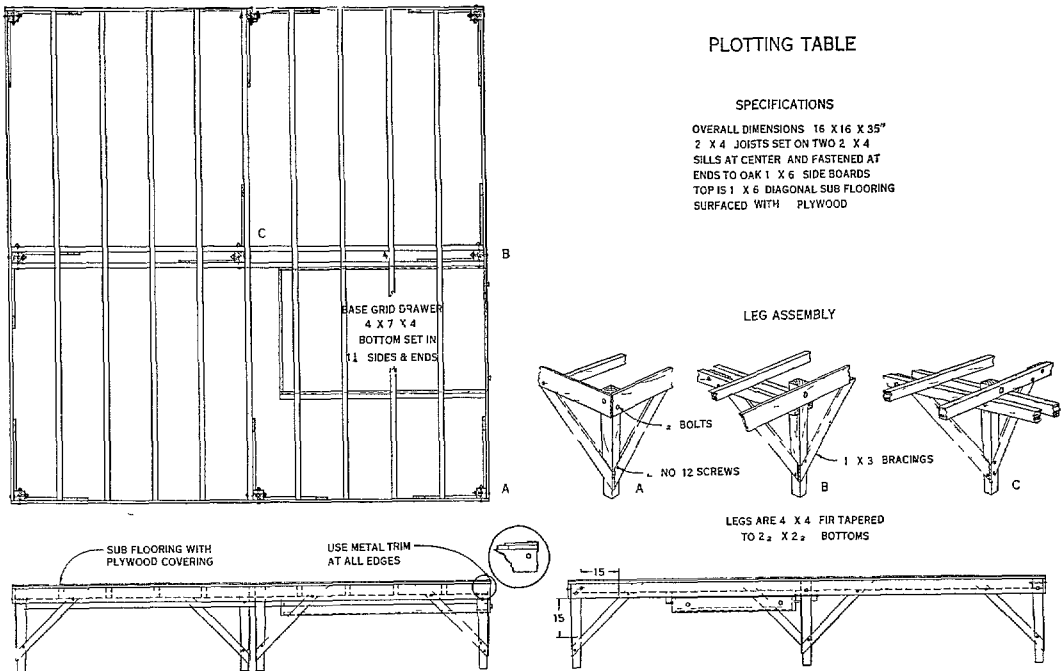

FIGURE 1 10 —Plotting table

be accurate, but the procedure is not satisfactory and should not be used, except in an emergency, because of the inevitable dirt and dust

Any radial-plot table must contain certain constructional details. It should be extremely sturdy, have an inflexible surface capable of supporting the weight and the movement of several persons, and should be large enough to meet the expected needs of the photogrammetric office. For most radial plots laid by the Coast and Geodetic Survey, the table shown in figure 1 10 is adequate. The height may be varied as desired. Standard sizes of plywood can be used for the table top which should be painted with white enamel so that the lines and the figures on the transparent base grids and projections can be seen easily. Also it is occasionally desirable to construct a base grid or projection directly on the enameled surface.

### 1425 Cabinets

For the efficient operation of a photogrammetric office arrangements must be made for the orderly and systematic filing of all data, related materials, and supplies. Adequate cabinets must be available in which to file photographs, projections, grids, map manuscripts, copies of current and prior surveys and maps, horizontal and vertical control data, stationery, forms and like supplies, and small instruments.

Nine-lens photographs should be filed in cabinets large enough so that the edges of the photographs will not be torn or mutilated when they are being filed or removed for use. Unmounted nine-lens photographs should be filed flat, but mounted nine-lens photographs should be filed vertically.

Smaller cabinets should be provided for trimmed nine-lens photographs and enlarged single-lens photographs. Letter files are excellent for contact single-lens photographs.

These photographs should be filed vertically for accessibility and should be pressed tightly together to keep them from curling or warping

Standard metal chart cabinets are excellent for projections, grids, map manuscripts, maps, and surveys. Grids or projections that are too large to be filed flat in these cabinets should be placed in a large drawer like that shown in figure 1 10

### 143 RATIO REFLECTING PROJECTORS

The delineation of radial-controlled map manuscripts is often expedited by using ratio projectors. With one of these instruments the detail of a photograph can be reduced or enlarged as desired to the exact scale of a map manuscript.

The Coast and Geodetic Survey uses overhead ratio reflecting projectors. Those built in the Bureau are designed so that metal-mounted nine-lens photographs can be placed in the photograph holders. The commercial instruments are designed for single-lens photographs, but unmounted nine-lens photographs can be used in them. Although mechanically different, both types of machines are the same in principle.

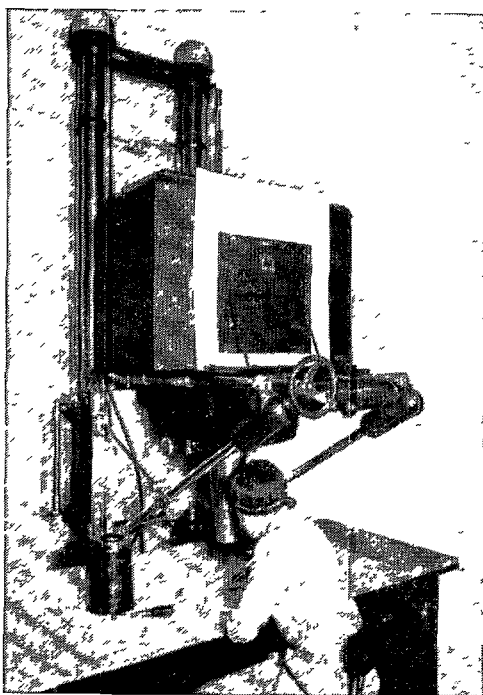

FIGURE 1 11—Ratio reflecting projector

A ratio reflecting projector (see fig 1 11) consists of a stationary horizontal table and a movable upper assembly, or lamphouse unit, containing a vertical photograph holder, bellows, lens, lights, and a front-surface mirror inclined at an angle of  $45^\circ$  to both the horizontal table and the vertical copy holder. This arrangement of the lens and the mirror with reference to the vertical photograph holder results in the projection of a direct image on the horizontal table. Sharp focus and correct magnification of the image are obtained.

by moving the lamphouse unit vertically and by moving the lens along its axis. All parts are moved manually on the projectors built by the Bureau. On commercial machines the lamphouse unit is moved electrically. Two 500- or 750-watt 120-volt T-20 projection lamps with mirror reflectors provide the illumination. To avoid overheating the photographic prints, the lamphouse unit is ventilated by means of an electric blower.

The lenses used in ratio projectors are generally of the symmetrical type rather than the type used in aerial cameras—that is, the image can be enlarged or reduced by raising or lowering the lenses. Additional lenses of various focal lengths may be substituted for the original projection lens if it is necessary to extend the range of magnification or reduction.

Square grids of fine lines ruled on metal-mounted paper large enough to fill the usable field of the projector are furnished for checking the accuracy of the projector and for use in its adjustment.

#### 144 STEREOSCOPES

A stereoscope is an optical instrument through the use of which a mental image of three dimensions can be obtained from a pair of photographs or diagrams. Overlapping pairs of vertical aerial photographs usually meet the special requirements for viewing with a stereoscope.

Several types of stereoscopes used in the Coast and Geodetic Survey are described in this section.

##### *1441 . Lens Stereoscope*

The simple lens stereoscope shown in figure 1 12 consists of two matched lenses mounted on a folding frame for field use. A similar device mounted on an adjustable nonfolding stand is used in the office.

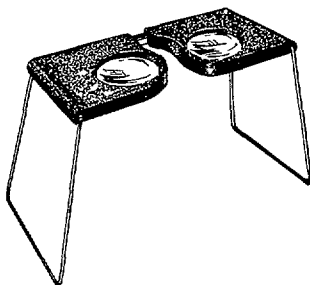

FIGURE 1 12 —Lens stereoscope

The lens stereoscope is a convenient and simple device for obtaining a clear magnified stereoscopic view from a pair of single-lens photographs. It is particularly useful in identifying images accurately in field inspection and in radial plotting. The impression of relative depth is exaggerated sufficiently, although not so much as with a small mirror stereoscope. In using both the field and office types, the photographs have to overlap each other to be viewed, giving a clear view of a strip approximately  $2\frac{1}{2}$  by 9 inches. A means is provided for adjusting the interocular distance of each type. The focus of the field type is fixed although that of the office type may be altered.

1442 *Mirror Stereoscope*

The mirror stereoscope (fig 1 13) used mostly by the Coast and Geodetic Survey is of wood construction and of sufficient size to view single-lens ratio prints or nine-lens photographs trimmed for field use. The over-all dimensions of the instrument are  $7\frac{1}{2}$  by  $8\frac{1}{2}$  by  $30\frac{3}{4}$  inches and those of the carrying case are 9 by 11 by 32 inches. The instrument is sturdy, light in weight, portable, easy to use, and yields a brilliant image with a large coverage. It has electric lighting fixtures, front surface mirrors, and may be equipped with simple lenses. The relief impression is greatly exaggerated, perhaps more so than in any other stereoscope of the Coast and Geodetic Survey. It is particularly useful in the field as well as in compilation offices and is used repeatedly by the operators of stereoscopic plotting instruments because of the clarity with which topographic detail can be interpreted. Images are reduced and the relief effect is exaggerated because of the long viewing distance necessary to avoid overlapping the photographs.

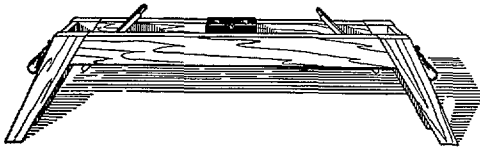

FIGURE 1 13—Mirror stereoscope

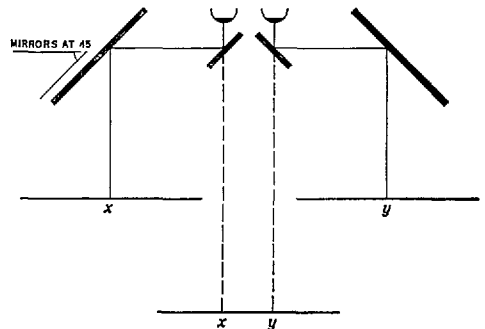

FIGURE 1 14—Principle of mirror stereoscope

A mirror stereoscope consists of two small mirrors about  $2\frac{1}{4}$  inches between centers, and two large mirrors, all set at  $45^\circ$  as shown in figure 1 14. Light from the separate images  $x$  and  $y$  is thus conducted by reflection to the separate eyes as though it emanated from  $x'$  and  $y'$ , giving the desired stereoscopic impression. Convergence and accommodation are not critical considerations in this instrument because the object separation  $xy$  can be adjusted.

Front surface mirrors eliminate the occurrence of troublesome "ghost" images, and little illumination is lost as compared to that lost using ordinary mirrors. Inasmuch as the front surfaces consist of a very thin evaporated metallic film, they are easily marred and their reflective power may be permanently reduced from finger prints on them. They should be protected from dirt and excessive handling and be cleaned by washing gently with cotton soaked in a solution of water and alphasol.

A simple lens may be placed between the eye and the small mirror to improve noticeably the clarity, brilliance, and eye comfort and to yield a slightly larger image. The focal length should be equal to or greater than the path of light from the lens to the photograph. In this instrument the focal length is 20 inches, or the power is 2 diopters.

1443 *Prism Stereoscope*

The prism stereoscope (fig 1 15) is a large instrument specially built for viewing nine-lens photographs. It is particularly suitable for image identification in radial plotting.

and the delineation of map features in compilation because it presents a clear magnified image of sufficient relief impression. It is large enough to accommodate nine-lens photographs without having to overlap them. The stereoscope has a small field of view, however, it is mounted on a carriage of parallel movement that can be moved freely so the entire overlap area can be seen without changing the orientation of the photographs. The instrument has two sets of eyepieces—one with a two-power magnification having a field of about 4 inches, and the other with a four-power magnification having a field of about 2 inches. Each eyepiece can be focused separately, and the interocular distance can be adjusted. An adjustment is also provided on some instruments for slightly changing the magnification or scale of either photograph.

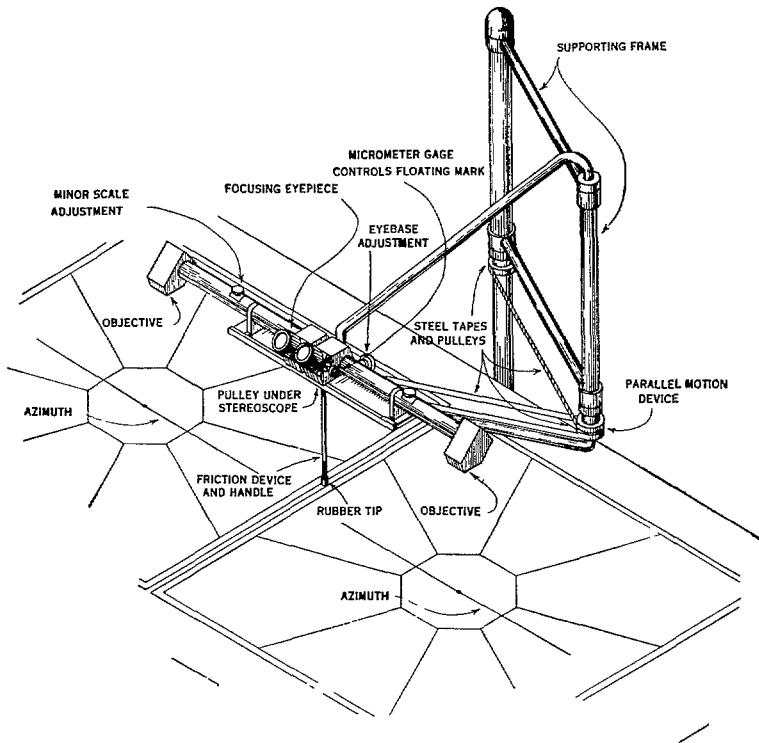

FIGURE 115—Prism stereoscope

The prism stereoscope resembles a mirror stereoscope in principle.<sup>11</sup> The reflections are performed by the internal reflecting surfaces of prisms instead of mirrors. A rather complicated telescopic system of lenses is used to magnify the image, and the optical system is enclosed to keep out dust and stray light.

A small prism stereoscope that has recently become available and which is excellent for field use is described in chapter 9.

#### 1444 *The F 71 Fairchild Stereoscope*

The F 71 Fairchild stereoscope (fig 116) is a mirror-type stereoscope—front surface mirrors are used for the outer reflecting surfaces, and prisms are used at the inner

surfaces. Simple lenses are included to facilitate vision. The instrument is designed primarily for use with 9- by 9-inch photographs, the common overlap of two such photographs can be viewed in its entirety with but a slight movement of the head and with no movement of either the photographs or the stereoscope. The total viewing distance is about 12 inches.

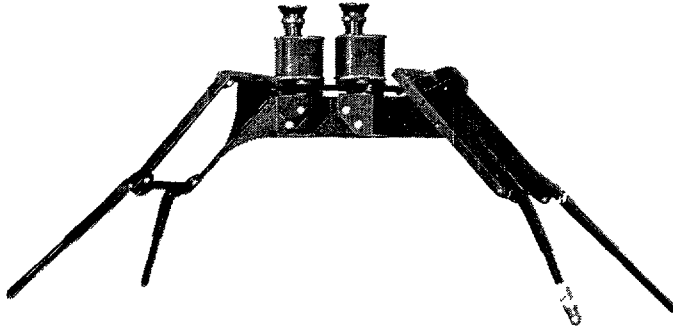

FIGURE 1 16—F 71 Fairchild stereoscope

Four-power binoculars that have a field of view  $1\frac{1}{2}$  inches in diameter are also furnished. The interocular distance of these binoculars can be readily changed, and each eyepiece can be focused separately by a screw adjustment. The binoculars are held in position by spring pins but can be rotated out of position. They can be removed altogether by simply compressing the spring pins.

Handles are provided on the stereoscope in an effort to overcome the tendency to touch the mirrors while moving it. Protector pads are furnished to prevent injury to the mirrors during transportation. The instrument stands on legs that can be folded for packing into a convenient case. The length of one of the legs can be adjusted by a simple knurled nut.

A very bright, clear image is obtained with or without the binoculars. The binoculars create a small amount of parallax distortion which tends to make a level area appear to slope slightly downward at the outer edges, but this may not be objectionable if they are used principally for picking points and/or identifying control. Use without the binoculars results in sufficient helpful relief exaggeration.

## 15 PROJECT PLANNING—PHOTOGRAMMETRIC OFFICES AND FIELD PARTIES

The photogrammetric surveys of the Coast and Geodetic Survey for the production of both planimetric and topographic maps are confined to the coastal areas and the shores of navigable waters of the United States and its possessions, and their primary purpose is to furnish shoreline and hydrographic control for hydrographic surveys and detailed topographic information for nautical charts. The surveys are arranged areally in projects that depend on the requirements of this Bureau for their location and limits and for the types and the scales of the resulting maps. Each project is identified by a code number, such as Ph-12(46), Ph-15(47), etc., in which the letters Ph stand for Photogrammetry, the next number indicates the consecutive number of the project, and the number in parentheses indicates the year the project was initiated. A project may be subdivided into smaller parts with each identified by a capital letter appended to the project code number, such as Ph-12A(46) and Ph-12B(46).



There are normally three separate and distinct phases to each photogrammetric project—(1) the aerial photography, (2) the required field or ground surveys, and (3) the compilation at the photogrammetric offices of the map manuscripts from the photographs and the related field surveys. In special cases phases (2) and (3) may be assigned to and accomplished by the same Officer-in-Charge and party personnel. When the phases of a project need to be distinguished—especially in identifying project instructions—the code number is followed by the word “Aerial,” “Field,” or “Office.”

Each project is defined by areal limits. The sizes of the projects vary from those that are small, specialized, and of short duration to those that require several seasons. Several projects, the field surveys of which are done by one or more field parties, may be assigned to one photogrammetric office for office processing. Large projects are usually planned for seasonal field work so that field parties operate in the north during the warm part of the year and shift southward to another project during winter until work can be resumed again in the north.

The areas to be mapped are selected and the project plans are made to satisfy primarily the nautical chart needs of the Bureau. But after such an area has been selected, the over-all federal economy and the map requirements of other agencies and of the public are considered. In all cases, special emphasis is placed on the data required for hydrographic surveys and nautical charts, such as the mean high-water line in detail, the aids to navigation and landmarks for charts, control stations for hydrographic surveys, offshore features visible on the photographs, Coast Pilot revision data, and bridge clearances.

The three types of maps produced by photogrammetric methods are as follows:

(a) *Topographic maps* with contours are required for nautical charts where the coastal area is not flat, they are made of other coastal areas where planimetric maps are required but where topographic maps are nonexistent or are obsolete because of age or scale. In the latter case, topographic maps are made by the Coast and Geodetic Survey in the interests of public economy.

The topographic maps comply with accepted standards as to map content and with the National Mapping Standards for a publication scale of 1:24,000 as to accuracy. They extend inland from the shore to include the limits of the first tier of 7½-minute quadrangles along the coast. The map manuscripts include the special data required for hydrographic surveys and for nautical charts.

These maps are published and distributed by the Geological Survey of the Department of the Interior. The map manuscripts are forwarded to the Geological Survey for publication at some production stage after compilation and review and prior to printing.

(b) *Planimetric maps* are complete as to planimetry—the horizontal representation of features—but they contain no contours or representation of relief. They are made where contours are not required [see (a) above]. Their limits are similar to the limits of topographic map projects. Planimetric maps comply with the National Standards of Map Accuracy as to accuracy of horizontal position. They are generally compiled and published at the scales of 1:20,000 or 1:10,000 with a few city areas at 1:5,000. The published maps, in one color only (black), are distributed by the Coast and Geodetic Survey.

(c) *Shoreline surveys* are essentially planimetric maps restricted in extent to the shoreline and a narrow zone (generally only a few hundred meters in width) immediately adjacent thereto. They are not published for distribution but a copy of each shoreline manuscript is printed and permanently filed in the Archives of the Bureau. Photographic reproductions of this file copy are furnished to those requesting copies.

The term “shoreline survey” is used instead of “shoreline map” because the coverage is limited and the surveys are not published as maps. Shoreline surveys are also made by planetable, in which case they are often limited to the shoreline with most interior details omitted.

Shoreline surveys are made where neither planimetric nor topographic maps are needed, as, for example, where the data on recent maps are generally adequate for nautical charts but shoreline at a larger scale with hydrographic control is required for contemporary hydrographic surveys or for a new large-scale chart.

## 151 PROJECT INSTRUCTIONS FOR TOPOGRAPHY AND PLANIMETRY

Project instructions, to supplement the published manuals, are written in the Washington Office and issued for each photogrammetric project. These instructions deal with the following general subjects: general, horizontal control, field inspection, hydrographic data, vertical control, contouring, compilation, field edit, and records. The details of the instructions vary from specific to general, depending on the locality and the nature of terrain and whether prior surveys have been made by the Coast and Geodetic Survey.

After operations have been started on a project, supplemental instructions are sometimes required to modify or supplement the original instructions. These are issued as additional facts come to the attention of the Officer-in-Charge or the Washington Office. They are identified by adding the code "Sup 1," "Sup 2," etc., to the code number identifying the project, thus, the second supplemental set of instructions for field surveys on a project might be identified as Ph-12(46)Field-Sup 2. In all correspondence, all Descriptive Reports, season's reports, special reports, and transmission of data, which refer to the operations of the projects, reference shall be made to the complete code number identifying the applicable project instructions or supplemental instructions.

The Officer-in-Charge shall acknowledge the receipt of all project instructions and supplemental instructions. He is required to make a careful study of them as soon as the instructions and the accompanying data are received. He should report immediately to the Washington Office any revisions of the requirements which he recommends, any parts of the instructions which are not clearly understood, or any subjects relative to the project about which he desires more complete or additional information. The Officer-in-Charge is urged, if the progress of operations discloses the need therefor, to make specific recommendations for amendments to the original instructions or for a change of procedure or methods of operation for the successful completion of the project.

### *1511 General Instructions*

The general part of the instructions specifies the types of map manuscripts to be produced and their scales, the project area, the section in which operations are to begin, and the desired direction of progress.

Where there are prior Coast and Geodetic Survey planimetric or topographic maps within a project, the extent and methods of revision are defined. Where adequate and up-to-date surveys or maps by other government or local agencies are available within a project, special instructions will cover the use and examination of these. Junctions that are to be made with prior surveys will be designated.

When special coordination between field parties and a photogrammetric office is needed to handle records or to maintain a continuous flow of data from one to the other, special instructions are included.

Consultation and cooperation with officials of other organizations may be required.

Registry numbers are assigned to the various map manuscripts.

For cost accounting purposes, or otherwise where justified, a project may be subdivided into smaller parts.

### *1512 Instructions for Horizontal Control*

A known deficiency of control within a project will be disclosed, and the areas that are inadequately controlled will be indicated in the project instructions. They will also

specify whether or not all control stations within the limits of a project are to be searched for and identified on the photographs. However, if there is a plethora of control, minimum spacing of the recovered and identified control stations will be specified. On some projects the Washington Office may indicate on the horizontal control layout or triangulation diagram, the control which must be either recovered or replaced by new control and the approximate placement of additional control. All this control must be identified adequately. The horizontal control layouts, triangulation diagrams, copies of all geodetic positions, and descriptions of stations will be forwarded with the project instructions.

The instructions may specify the map manuscripts, or the percentage of map manuscripts, within a project that are to be tested for horizontal accuracy and may specify that certain existing horizontal control be withheld for that purpose.

Unless otherwise specified in the project instructions, all triangulation shall comply with the requirements of Special Publication No 145, Manual of Second- and Third-Order Triangulation and Traverse<sup>4</sup>, as supplemented by section 22 of Special Publication No 143, Hydrographic Manual.

All third-order traverse shall comply with the requirements described in this manual, unless otherwise specified by project instructions. Where geodetic control of other organizations is known to exist within the project area, special instructions will be included for its use.

#### *1513 Instructions for Field Inspection*

The instructions specify the field-inspection operations that are to be completed within a project. A thorough inspection of shoreline and alongshore detail is always required.

Any areas where certain phases of field inspection are to be omitted will be defined.

Regardless of the type of survey or map to be produced, the field inspection shall be made in accordance with the requirements in this manual, except as amended by the project instructions.

#### *1514 Instructions for Hydrographic Data*

The project instructions specify if photogrammetric surveys are to furnish control data for new basic hydrographic surveys. Where contemporary hydrographic surveys are not contemplated, the project instructions will specify the amount of hydrographic control to be established and its spacing.

If advance information prior to the routine completion of the project map manuscripts is required for immediate use in chart correction, the requirements and the methods of forwarding the data will be specified.

The instructions will specify whether or not information is to be submitted for the revision of the Coast Pilot in the project area. Coast pilot reports, when required, shall comply with the requirements of section 91 of Special Publication No 143, Hydrographic Manual.

All hydrographic data shall comply with the requirements of this manual and the Hydrographic Manual, except as amended by project instructions.

#### *1515 Instructions for Vertical Control*

Where topographic maps are to be compiled, the descriptions and the elevations of bench marks established within the project area by this Bureau and the U. S. Geological

<sup>4</sup> The requirements for triangulation are being superseded by Special Publication No 247, Manual of Triangulation and at a later date the requirements for traverse will be issued in a separate manual.

Survey and those of any other organizations that are on file in the Washington Office will accompany the instructions. Level diagrams showing the various level lines will be furnished when they are available. Additional vertical control found by the field party within the project area, but for which no data were furnished with the project instructions, is to be reported to the Washington Office with full details before use.

The instructions will specify the methods to be used in determining supplemental elevations and their distribution throughout the project area. Where the elevations are for use in stereoscopic instrument mapping, a layout showing the required placement of the vertical control points will accompany the instructions. A photogrammetric office may be required to indicate on the field photographs, or mosaics of them, approximately where supplemental elevations are needed to control multiplex models most efficiently.

Coast and Geodetic Survey vertical control will be established and all control will be recovered and identified in accordance with this manual, except as amended by project instructions.

#### *1516 Instructions for Contouring*

Where topographic maps are to be compiled, the method or methods of contouring to be used and the contour interval are specified.

Where field methods are to be used, the instructions state whether the contouring is to be done directly on the photographs or on specially prepared lithographic copies of planimetric manuscripts. Any improved field methods will also be described.

Contouring in photogrammetric offices is done by stereophotogrammetric methods. Special instructions will describe any new procedures for contouring by such methods.

Contouring by field or office methods shall be done in accordance with the requirements in this manual, except as amended by project instructions.

#### *1517 Instructions for Compilation*

The compilation method required by the instructions for the various map manuscripts depends on the type of terrain and the Coast and Geodetic Survey's immediate requirements within the project limits.

Where shoreline and topographic manuscripts are to be made of the same area, the instructions will clarify the procedures to be followed so that no duplication of effort will ensue. All shoreline surveys are to be smooth-drafted, and all planimetric and topographic manuscripts are to be compilation-drafted, unless otherwise specified in the project instructions.

When special symbols or compilation procedures are required that differ from those described in this manual, detailed instructions will be issued regarding the desired changes.

#### *1518 Instructions for Field Edit*

The instructions specify the thoroughness with which all phases of field edit are to be made. This will be done to ensure that the planimetric and topographic manuscripts are complete and comply with the accepted standards for national mapping, including the National Standards of Map Accuracy and any special requirements of the Coast and Geodetic Survey.

Any phases of field surveys that have been omitted or slighted intentionally prior to compilation will be completed during field edit.

Horizontal and vertical accuracy tests will be specifically prescribed either in the original instructions or in correspondence with the Chief of Party

All field edit shall be according to the requirements in this manual, except as amended by project instructions

### *1519 Instructions for Reports and Records*

Various reports and records are required in connection with the photogrammetric surveys of any project. These reports and records shall be submitted to the Washington Office according to chapter 7 of this manual, except as amended by project instructions

## 152 COORDINATION OF PARTIES

So that the field and office phases of the work involved in any project will be properly coordinated, the photogrammetric office and the field party must keep each other informed as to their progress and immediate and future needs. After a project has been assigned to a photogrammetric office, continual correspondence with the field party is necessary to inform it of details, such as map manuscript grouping or plotting areas, adequacy and placement of vertical control if plotting instruments are to be used for contouring, and placement of additional horizontal control. Copies of each transmitting letter and each letter asking for field work of any importance should be forwarded to the Washington Office.

Table 1.3 lists chronologically the interdependent operations, or work phases of a project involving the Washington Office, photogrammetric offices, and field parties. This chronology shall be followed unless the project instructions specify exceptions. Variations that are sometimes specified are as follows:

(a) Phase 1(f) may occasionally be assigned to the photogrammetric office, in which case it becomes part of phase 2.

(b) Where contouring is done by field methods, it is sometimes necessary to perform phases 6 and 7 simultaneously with phase 8 in order not to delay the work of the photogrammetric office. In such case the photogrammetric office must complete the final operations in phase 8 after receipt of field inspection and contouring.

(c) If authorized, clarification and classification of detail may be postponed until field edit (phase 11) instead of being accomplished during field inspection (phase 7) when circumstances make this necessary in order to expedite compilation (phase 8). This increases the work of the photogrammetric office and is not so satisfactory as having a complete and independent field inspection.

(d) Boundary lines of political significance and of reservations should always be recovered in the field and shown on the field photographs and should not be left to be done as part of phase 11, except where a boundary line has to be "surveyed in" (i.e., run down by planetable), or where political boundary lines follow public land lines where monuments are to be located by photogrammetric methods.

(e) The same work phases are required for shoreline surveys and planimetric maps, except that additional vertical control and phase 6 are omitted.

## 153 PROJECT LAYOUTS AND GRAPHIC INDEXES

Project limits, determined by the requirements of the Coast and Geodetic Survey, are indicated graphically on charts or maps of the area. The map limits are then laid out within the project limits to conform as nearly as practicable to the 15-minute quadrangle map system of the United States. From this layout or copies of it additional operational plans and graphic indexes are made.

TABLE 13—Chronological outline of field party and photogrammetric office operations for photogrammetric mapping

FIELD PARTY	PHOTOGRAMMETRIC OFFICE	WASHINGTON OFFICE
		1 (a) Project layouts (b) Horizontal and vertical control indexes (c) Project instructions for aerial photography (d) Project instructions for field surveys (e) Project instructions for office compilation (f) Photograph control analysis and layouts of additional required ground stations (g) Accumulation of pertinent data, such as graphic indexes, photographs, etc
<sup>6</sup> 2 (a) Assembly and indexing of all data forwarded from the Washington Office (b) Preparation of field photographs	2 (a) Assembly and indexing of all data forwarded from the Washington Office (b) Preparation of office photographs	
3 (a) Recovery of horizontal stations and their marking on field photographs (b) Horizontal control surveys and marking the newly established horizontal stations on field photographs		
	4 (a) Determination of radial plot areas (b) Requests to field for any additional control which may be required (c) Radial plot	
5 (a) Recovery of vertical stations and their marking on field photographs (b) Vertical control surveys and marking the newly established vertical stations on field photographs		
6 Contouring } 7 Field inspection } may be combined		
	8 (a) Graphic compilation of map manuscripts (b) Compilation and contouring by stereoscopic instruments	
	9 Review and correction of map manuscripts	
		10 Inspection and reproduction of map manuscripts for field edit
11 Field edit and accuracy tests	11 Revision of the manuscripts after field completion	
		12 (a) Final review (b) Smooth drawings
		13 Reproduction

<sup>6</sup> Whenever a photogrammetric office is supervising the field operations, this work is to be done in the photogrammetric office and not by the field parties

All layouts and graphic indexes of photogrammetric projects are made in the Washington Office by the Division of Photogrammetry. Copies of the various layouts and indexes are forwarded with the project instructions so that photogrammetric offices and field parties can carry out effectively and systematically the required operations.

The layouts and indexes made in the Washington Office for each project, as discussed under subsequent headings, vary somewhat as to format and scale, depending on the type of project, the amount of detail to be shown, and the maps available for making them. The map layouts, horizontal control indexes, and photograph indexes are often combined into one project index. This index is made on topographic quadrangles where these are available and photographic copies, at a reduced scale, are forwarded to the field parties and photogrammetric offices. Where no maps exist for the project area, the diagram is made on a mosaic, or on a specially prepared reconnaissance sketch.

### *1531 Shoreline Survey Layouts*

The scale and sheet limits of shoreline surveys are generally the same as specified for planimetric maps, in 1532, except little attention is paid to quadrangle limits. However, the projections shall rarely, if ever, be skewed.

### *1532 Planimetric Map Layouts*

To conform to the quadrangle map system of the United States, planimetric maps at the scale of 1:10,000 will generally be laid out to embrace  $3\frac{3}{4}$  minutes of latitude and  $7\frac{1}{2}$  minutes of longitude or vice versa, at the scale of 1:20,000 they will generally embrace  $7\frac{1}{2}$  minutes of latitude and 15 minutes of longitude or vice versa. (See fig. 117.) However, where the coastline is very irregular, is indented by bays, rivers, and other bodies of water, or includes off-lying islands, such layouts are not always practicable, and the limits must be adapted to the configuration of the land, but they must not be skewed.

The field compilation scales and the publication scales of planimetric maps of the coastal areas of the United States are usually the same as the scales of the hydrographic surveys of the adjacent waters—generally 1:10,000 or 1:20,000 and exceptionally 1:5,000.

### *1533 Topographic Map Layouts*

The topographic maps of the United States are laid out to constitute a topographic atlas. For this purpose quadrangles bounded by parallels of latitude and meridians of longitude are used as the subdivisions of the country. Where an area, whatever its size, is subdivided, it is divided into quarters.

The compilation scale for coastal topographic maps is rarely smaller than 1:20,000, and in many areas the high-water line and adjacent areas are surveyed and compiled on a scale of 1:10,000 or larger, depending on the requirements of the corresponding hydrographic surveys and the nautical charts. These maps are published at a scale that provides a reduction from the compilation scale, but rarely at a scale smaller than 1:31,680 (1 inch = a half mile).

Figure 118 shows a project layout of standard  $7\frac{1}{2}$ -minute topographic maps.

U S COAST AND GEODETIC SURVEY

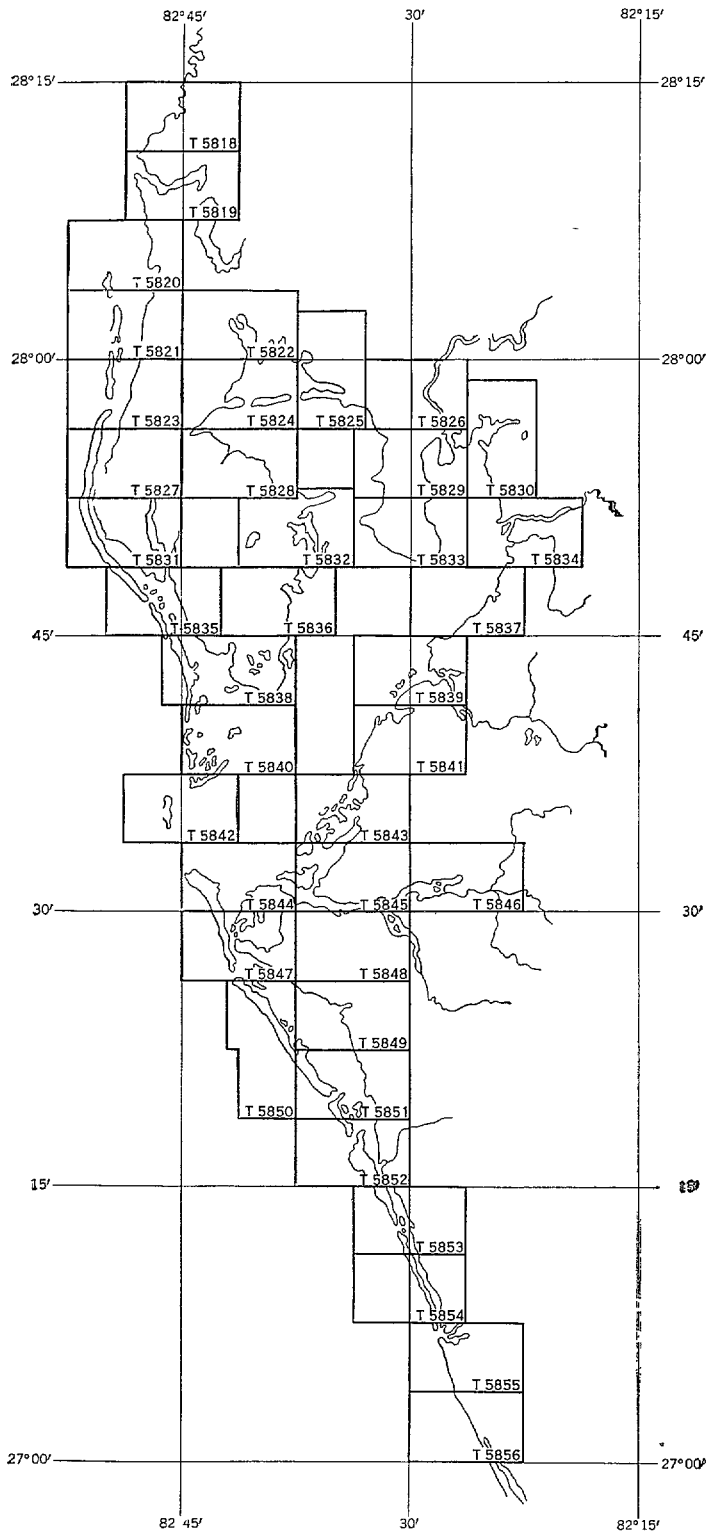

FIGURE 1 17 —Planimetric map layout



### 1534 Registry Numbers

A registry number is assigned by the Washington Office to each map in order to facilitate the correct and quick identification of that map. These numbers are assigned when a project is planned and are shown within the respective map limits on the project layouts. Such a number (T-8401) consists of the capital letter *T* (serving to distinguish between topographic and hydrographic surveys, the numbers of the latter beginning with *H*) followed by a hyphen and a four- or five-digit number. This number has no geographic or calendar significance. When a map is divided into two or more parts for delineation, each part shall be identified by the same registry number followed by a brief code to indicate the individual part of the total subdivisions, as T-8401( $\frac{N}{2}$ ), which would be the northern half of T-8401.

The assigned registry number is shown in 12-point lettering as part of the manuscript title which appears in the lower righthand corner of each map manuscript.

Map manuscripts shall be referred to by their registry numbers in all records, Descriptive Reports, and correspondence. In Descriptive Reports and all special reports and records that are retained permanently all references to registered maps, except those of the specific project, shall be by registry number followed by the year date in parenthesis, as T-8401 (1947).

### 1535 Names of Topographic Maps

Each standard topographic quadrangle map in the United States is named for a prominent geographic feature on that map. The United States Geological Survey is the authority for these names. Provisional names have already been assigned to most of the 15-minute quadrangles in this country but not to the 7½-minute quadrangles.

As it is not always practicable to select the most appropriate name for a quadrangle before it is mapped, the provisional names are often changed after the more accurate and detailed information resulting from the survey is available. For instance, the survey will sometimes prove that the feature for which the provisional name was selected is actually outside the limits of the map. Therefore, the names of topographic maps are selected by the Geological Survey during the final office edit stage. No recommendations for quadrangle names are ordinarily required from the field parties. Only in a case where there is doubt as to the most appropriate name or in a case where there is no apparent name will this Bureau be asked to make a recommendation. In such a case the field-edit party will be specifically instructed to investigate the situation and make the recommendation.

### 1536 Graphic Photograph Indexes

For each project, graphic indexes of aerial photography are made in the Washington Office. These indexes are used to locate and identify individual photographs and to determine whether the project area has been adequately covered by photographs according to the instructions and specifications. The adequacy of overlap of nine-lens photographs can generally be determined from a carefully prepared photograph index. On the other hand the adequacy of overlap of single-lens photographs shall always be determined by laying out contact prints as a mosaic. Where the photography is inadequate for any reason, the index can be used as a flight map on which to show the required reflights. In addition to the standard photograph indexes, a special index at a reduced scale (small enough to be

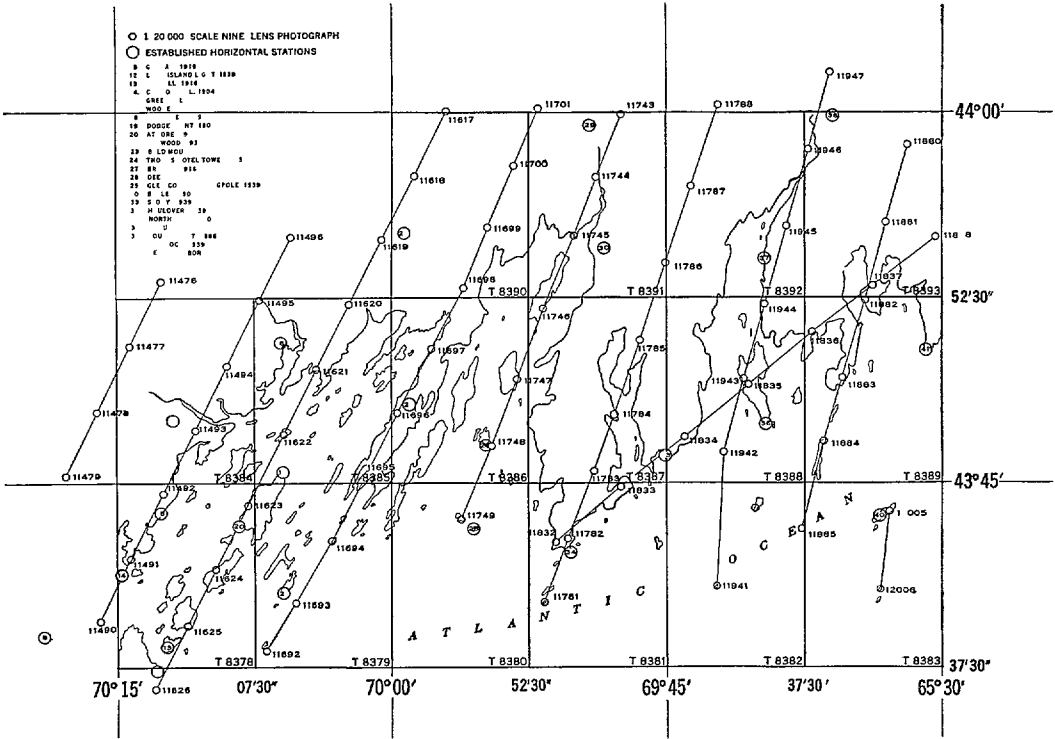

FIGURE 1 18 —Graphic project index

bound conveniently with project instructions) showing only the map layout, and possibly the aerial photography, for a particular project is useful

Nine-lens photographs can be indexed best on a copy of the map layout of a project (See fig 1 18) Where possible, each exposure is located by comparing the detail on the photographs to the topography on the map Where this cannot be done, as many photographs as possible are located individually The remaining photographs are spaced between the former and adjusted to the few topographic features along the estimated flight lines A templet indicating the area covered by a single photograph is often used for this purpose and is excellent for checking the adequacy of the forward and side lap To determine the size of the templet to represent a photograph on a map, the dimensions of the photograph are multiplied by the ratio of its scale to the scale of the map, for example,

$$35\ 4'' \times \frac{10,000}{62,500} = 5\ 66''$$

The dimensions of a nine-lens photograph are 35 4 by 35 4 inches, so the corresponding templates are made 5 66 by 5 66 inches in size for a photograph scale of 1 10,000 and a map scale of 1 62,500 Where great accuracy is required, the exact scale of the photography must be determined and used instead of the scale specified in the project instructions

After the map position of the center of a photograph is located and marked by a small circle as accurately as possible, the number of the photograph is shown alongside it The flight lines are also shown graphically

The index of single-lens photography will generally be a reduced reproduction of a mosaic of the actual photographs. To make such an index, the photographs are laid to form a shingle mosaic which is then photographed and reproduced at a reduced scale (usually about 1 mile to the inch) suitable for index purposes.

In addition to these project photograph indexes the Coast and Geodetic Survey has completely indexed all photographs in its files on sheets 18 by 24 inches, each including 1° of latitude and longitude in the United States, and 1° of latitude by 2° of longitude in Alaska.

### *1537 Graphic Horizontal Control Indexes*

Graphic horizontal control indexes include both triangulation and traverse stations and show as completely as possible all the available horizontal control that is likely to be useful in planning the photography and in controlling the aerial photographs of a project, including any control established by other agencies, such as the Corps of Engineers, the Geological Survey, or various State geodetic surveys. Some horizontal control stations may be omitted in certain local areas where the control is extremely dense. Newly established control stations are added in the photogrammetric and field offices.

A part of such an index is shown in figure 1 18. Each station on the index is referenced by number to the station name which is included in a typed list in some convenient place on the index.

It does not follow that any horizontal control station shown on these indexes may be used in connection with the establishment of additional geodetic control because some of them may not be sufficiently accurate for this purpose, and some may not be adjusted to the North American 1927 datum.

Copies of triangulation diagrams showing Coast and Geodetic Survey triangulation stations adjusted on the North American 1927 datum will ordinarily be forwarded with the project instructions. These diagrams show all stations, the main scheme lines that have been observed, and the station names. They are referred to constantly in photogrammetric offices. State maps showing this horizontal control are at a scale of about 1 800,000 and are references for interior control, the scale of the diagrams of the coastal areas is approximately 1 120,000.

### *1538 Graphic Vertical Control Indexes*

To avoid unnecessary confusion, vertical control should generally not be included on the horizontal control indexes, separate graphic vertical control indexes should be made. The systematic recovery of bench marks in the field is facilitated by these indexes, and they are used in the photogrammetric office to check the completeness of this phase of the field work.

Graphic indexes of the vertical control established by this Bureau are made by the Division of Geodesy. As these indexes are at a relatively small scale, the positions of the bench marks cannot be shown—only the level lines are shown. The principal level lines are named, as Fort Pierce - Punta Gorda (indicating that the line was run between these two localities). Where many lines are concentrated within a small area, that area is given a suitable name and the lines within that area are numbered.

The Division of Photogrammetry will generally prepare for each project a special graphic index on large-scale maps or mosaics showing the positions of the bench marks. In addition to the bench marks established by the Coast and Geodetic Survey, those of the

Geological Survey and State geodetic surveys that are tied to the federal net are shown. If such an index is not prepared by the Division of Photogrammetry, it shall be prepared by the field party and copies of it shall be furnished to the photogrammetric office.

### *1539 Graphic Project Indexes*

A graphic project index is an integration of the project map layout, photograph index, and horizontal control index. It is furnished by the Washington Office for each project, generally at the scale of 2 miles to the inch. Because this index is in constant use, it should be cloth-backed. The Washington Office will furnish on request cloth-backed copies of any index prepared there.

Where special vertical control indexes are lacking, recovered bench marks can be indicated on this graphic project index from which supplemental levels can then be planned.

For field parties and photogrammetric offices this index is important and necessary to show graphically the relationship of the various work phases to each other—their plan for execution, progress, and completion. It can also be used by field parties to indicate the following:

- (a) Receipt of field photographs
- (b) Recovery of horizontal control
- (c) Distribution of control on each photograph
- (d) Assignment of field surveys by map limits to subparty chiefs
- (e) Transmittal of all field data for each map manuscript

Photogrammetric offices can also use this index to indicate the following graphically:

- (a) Receipt of office photographs
- (b) Receipt of control data and identified stations from field party
- (c) Determination of the adequacy of the control with reference to the photographs and the map limits
- (d) Placement of additional required control
- (e) Location of radial-plot limits
- (f) Assignment of map manuscripts for delineation
- (g) Completion and transmittal of map manuscripts
- (h) Indication of junctions

A graphic project index is shown in part in figure 1 18. Field and photogrammetric offices can indicate the receipts of their respective field and office photographs by filling the proper small photograph circles with ink. When a control station is recovered and identified, its circle is also filled with ink, however, this ink must be translucent in order not to obliterate the key number.

Approximations in the locations of the horizontal control stations and the photograph centers should be allowed for in determining the need for additional horizontal control or its placement.

### **154 PROJECT SOURCE MATERIAL**

The Washington Office furnishes certain source material or data for each project to supplement the project instructions and to ensure that the same information is available to the Washington Office, the photogrammetric offices, and the field parties. Copies of the following source material are usually furnished: geographic positions or coordinates and descriptions of horizontal control, descriptions and elevations of vertical control, maps, charts, and surveys of the area, and any other available data useful in carrying out the

instructions Some of these data must be further indexed and cataloged by the photogrammetric offices and field parties so that all employees can make full and systematic use of them

Adequate index systems are necessary for the efficient operation of photogrammetric offices and field parties Their use reduces the time spent in locating misplaced material and ensures that all available source material and data are used

#### *1541 Photograph Card Indexes*

Photogrammetric offices and field parties should keep a record of each photograph and diapositive received A card index is most satisfactory for this purpose Photogrammetric offices should have separate files for office and field photographs Only one file—for field photographs—is needed by a field party See 1572 regarding the numbering of field photographs

A card is made for each nine-lens photograph when it is received from the Washington Office, giving the photograph number, date of receipt, project number, and any other information desired by the Officer-in-Charge Further transmittals of the photographs should be recorded, giving the dates and destinations If there are several prints of the same nine-lens photograph, these may be individually identified by numbers suffixed to the photograph numbers, such as 12722-1, 12722-2, 12722-3, etc

Card indexes should be kept for single-lens photographs and diapositives, but it is not always necessary to number each duplicate print It is suggested that the photographs and diapositives for a single map be grouped on a card, however, any system of indexing may be used that will provide a satisfactory record

#### *1542 Control Records*

Photogrammetric and field offices repeatedly use the geographic positions or coordinates and descriptions of the horizontal control stations and the descriptions and elevations of the vertical control stations in a project area These data must be filed systematically for easy reference

The Coast and Geodetic Survey publishes geographic positions and coordinates on sheets approximately 5 by 8 inches in size, indexed alphabetically by States For office use these can be filed in ring binders of suitable size entitled as follows

Project Ph-9 (46)  
Geographic Positions  
C & G S Triangulation and Traverse  
Florida

---

Project Ph-9 (46)  
Coordinates  
C & G S Triangulation and Traverse  
Florida

The alphabetical indexes of the positions should be requested from the Washington Office if they do not accompany the data

Descriptions of these horizontal control stations are published on both sides of letter-size paper The original descriptions and all subsequent recovery information available are included They are grouped by areas and issued in numbered pamphlets with a title

to identify the area, such as "No 424, Florida Keys, South Miami to Tavernier" Each pamphlet is indexed by the Washington Office

For use in photogrammetric offices the pamphlets and their indexes can be filed in ring binders of suitable sizes entitled as follows

Project Ph-9 (46)  
Descriptions  
Triangulation and Traverse  
Florida

For field party use descriptions should be obtained in duplicate and cut up so that the description of each station can be pasted onto a blank 5-by 8-inch card Field recovery data can then be recorded on these same cards, thus keeping together all recovery information about each station These cards are filed by map numbers in wooden boxes marked as follows

Project Ph-9 (46)  
Horizontal Control Descriptions  
Map Nos T-5800 - T-5850  
Florida

The descriptions and elevations of vertical control are published in the same manner as the descriptions of horizontal control They are generally arranged in the consecutive order of the bench marks along the line of levels Lines are grouped together by areas and issued in pamphlets These bench marks must be indexed—by the photogrammetric offices if this is not done by the Washington Office Vertical control data should be filed in the same way recommended for horizontal control descriptions

Tidal bench mark data are issued by States in published indexed pamphlets, usable as issued

Horizontal and vertical control data furnished by the Washington Office for stations established by other government agencies, such as the Corps of Engineers, Geological Survey, and various State geodetic surveys, vary in format, but should be filed and indexed systematically for most efficient use

#### *1543 Map Records*

After a project has been assigned to a field or photogrammetric office and the instructions and map layouts have been received, a separate manila folder identified by registry number should be made for each map in the project All information and data relating to each individual map shall be placed in such a folder and filed for reference and use

#### *1544 Maps and Prior Surveys*

Copies of maps and prior surveys of a project area which are believed to be useful in connection with the project will be furnished to photogrammetric offices and field parties by the Washington Office The project instructions will specify what basic use can be made of these maps and surveys Such source material is usually limited to copies of maps, surveys, and plans of the Coast and Geodetic Survey, Geological Survey, Corps of Engineers, Bureau of Land Management, Department of Agriculture, and Post Office Department Copies of maps showing the boundaries of political subdivisions and incorporated places, specially prepared by the Census Bureau, are also furnished

The field party must be alert to its responsibility to discover locally maps, blueprints, or copies of surveys that may serve as source material and which are unknown to the Washington Office. Where the use of such data requires an amendment to the project instructions, the Washington Office should be informed of the potential value of the new data with a recommendation as to its use.

Any such maps or copies of surveys used by the field party in connection with a project shall be forwarded with other field data to the office compiling the project.

All such map and survey data must be filed for ready accessibility and use. Field parties rarely have chart cases or filing cabinets large enough for filing such maps. They can often be bound together for use in the field in covers made of heavy boat sheet or drawing paper. Although photogrammetric offices have filing accommodations for such material, it is better for any such material in active use to be bound as above and not filed so that its use will not be overlooked.

### 155 CLASSIFIED DATA

The term "Classified Data" or "Classified Information" means official information—generally in the form of photographs, plans, or maps—the security protection of which is necessary for the national welfare. Classified data may be TOP SECRET, SECRET, CONFIDENTIAL, or RESTRICTED, depending on the degree of protection necessary to safeguard it.

Coastal mapping projects often include military reservations or other areas, or installations within these reservations or areas, the existence of which may be classified, or information about which may be classified. In such instances certain of the photographs, plans, or maps furnished by the Washington Office will be classified. Further, the photogrammetric field parties may obtain classified source material for a project. Classified material will ordinarily be designated as "RESTRICTED" or "CONFIDENTIAL". Occasionally such material may be designated "SECRET", TOP SECRET material probably will never be used.

All classified material submitted to the custody of a field party or photogrammetric office shall be safeguarded in accordance with Department of Commerce Administrative Order 207-2 dated 14 December 1948, and published in Part 2 of the Department of Commerce "Manual of Orders". A field party or office handling such material shall have a copy of Administrative Order 207-2 and shall safeguard all classified material in accordance with that order. The regulations contained therein are in considerable detail. They are summarized below.

1 No person is entitled to knowledge, or possession, of classified information solely by virtue of his office or position. Such information will be entrusted only to those individuals whose official duties require such knowledge or possession.

2 In working with classified information, the handling of SECRET and CONFIDENTIAL material will be held to the absolute minimum. Only that portion of such material necessary for appropriate official action shall be released to any employee. When not in actual use by, or under the direct observation of, an authorized employee, it shall be filed from view. During field surveys when it is necessary to discuss classified information with persons outside the Bureau, SECRET or CONFIDENTIAL information shall only be discussed with or shown to the official in charge of the particular reservation or area, or his authorized representative. Restricted information shall only be discussed with or shown to officials of the executive branch of the Government.

3 Classified information shall not be released to individuals outside the Bureau except on written authority obtained through the Washington Office.

4 When transmitted, SECRET and CONFIDENTIAL material shall be enclosed in opaque inner and outer covers. The inner cover shall be sealed and plainly marked with the assigned classification, the outer cover shall be sealed and addressed with no indication of the assigned classification. For SECRET material, a receipt shall be attached to the inner cover or to the material itself, to be signed by the addressee and returned to the sender. Receipts are not necessary for CONFIDENTIAL material but may be used if the sender deems it necessary. RESTRICTED material may be enclosed in one cover only.

5 SECRET and CONFIDENTIAL material shall be transmitted by registered mail.

6 In photogrammetric offices SECRET and CONFIDENTIAL material shall be filed in metal field cabinets with combination locks, or in steel lock-bar and padlock-equipped cabinets, when not in use. When mobile field parties have such material, it shall be locked up when not in use, and shall be forwarded to the photogrammetric office or the Washington Office as soon as the necessary field work has been completed.

156 ORDERING PHOTOGRAPHS

To order aerial photographs properly, the identifying marks on nine-lens and single-lens photographs must be understood.

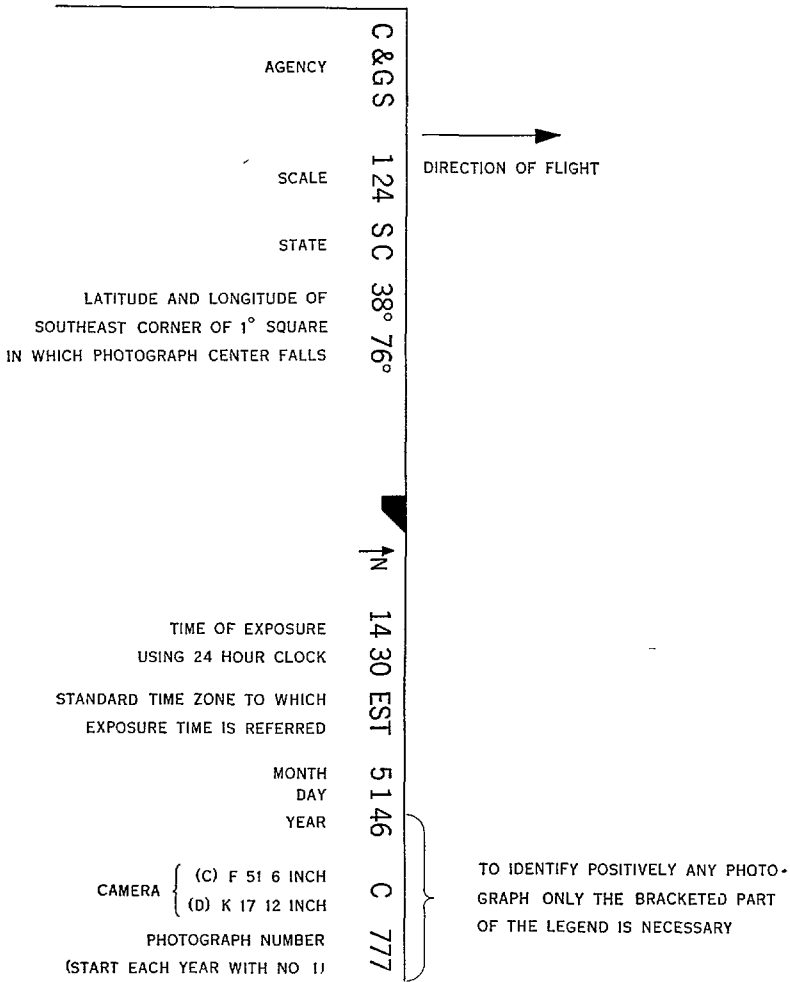

FIGURE 1 19 —Key to data stamped on single lens aerial photographs



Nine-lens photographs are numbered consecutively without reference to year, date, or scale so that any photograph is uniquely identified solely by its number. With reference to the direction of flight this number is in the forward right-hand corner of each photograph in chamber no. 7.

Each single-lens photograph has an identifying code legend (fig. 1.19) across its forward edge in the direction of flight. The last three parts of this code—year, camera letter, and photograph number—are essential for the identification of any single-lens photograph.

The code letters for the various cameras are

	<i>Code letter</i>
Original nine-lens camera (all photographs prior to September 1, 1945) .....	A
Rebuilt nine-lens camera (all photographs after September 1, 1945) .....	B
Fairchild F-51—6" Metrogon lens .....	C
Fairchild K-17—12" lens .....	D
Fairchild K-17—40" lens .....	G
Fairchild K-17—6" Metrogon lens .....	J
Fairchild Cartographic—6" Metrogon lens .....	O

Camera "G" was borrowed for experimental photography and is no longer used. See 22 for descriptions of the cameras listed here.

Form L-1-5, Photogrammetric Laboratory, in duplicate, is used in ordering all photographs, including rectified nine-lens and single-lens photographs and diapositives.

In using this form, the type of photograph must be indicated. For nine-lens photographs the type of paper and whether the photographs are to be mounted must be stated. The single-lens photographs must be identified by the three parts of the code number, the type of paper and whether contact or ratio prints are wanted must be indicated. For ratio prints a ratio less than unity (as 0.95) signifies a reduction, and a ratio more than unity (as 2.05) signifies an enlargement.

Photographs should be ordered as soon as the need for them is definitely known, and the date they are needed should be given on the form. When certain photographs are urgently needed, they should be ordered on a separate form to receive prompt attention and not included on the same form with a large order which may take considerable time to complete.

## 157 PHOTOGRAPHS FOR FIELD WORK

### *1571 Field Photographic Charts*

To use field photographs most advantageously, a chart showing the phases of operation to be executed on the different photographs is excellent. This chart helps ensure the systematic completion of the various field operations for an entire map and shows the photograph junctions to be made on adjoining maps.

Figure 1.20 shows a typical field photograph chart, only a sketch is necessary. Such charts or sketches are particularly helpful where planetable contouring is done on photographs. The charts can best be made by the field party when the photographs are prepared for field work.

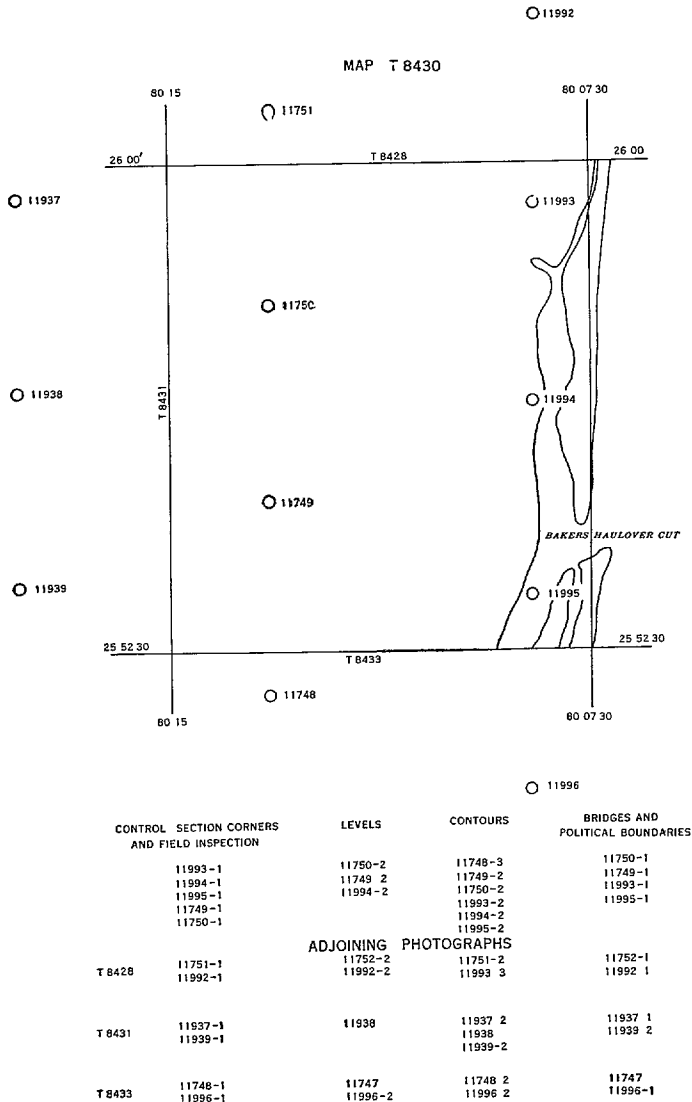

FIGURE 1 20 —Field photograph chart

### 1572 Field Photograph Preparation

Generally one print of each photograph within a project is forwarded to a field party with the project instructions or soon thereafter. With these photographs and instructions, the Officer-in-Charge can determine the most suitable usage and the most economical number of prints of each photograph that will be required to execute the assigned field operations efficiently. Nine-lens photographs are costly, and duplicate prints must be ordered with conservatism, on the contrary, there should be no hesitancy in ordering as many copies of single-lens photographs as are needed.

Where practicable, the field work of each map should be complete in itself—that is, any one photographic print should contain field work for only one map. The limits of the area to be worked in the field on each photograph should be outlined in light red pigment.

ink with the number of adjoining photographs in the margins. Map limits with their latitude and longitude should be inked in yellow pigment ink as accurately as possible on all photographs on which they fall. To allow for possible discrepancies in the location of the map limits, a narrow zone of overlap should be provided, a light red line should be shown outside the yellow line to indicate this overlap. No such factor of safety need be allowed for photograph junctions within the limits of a map, therefore the lines indicating working area limits must be accurately transferred to other photographs to avoid leaving any area unsurveyed.

If planetable contouring is to be done on photographs in the field, the drainage and ridge lines should be previously inked under a stereoscope. Only experienced photogrammetrists shall be assigned to this duty. The drainage lines should be in white pigment ink and the ridge lines in red waterproof drawing ink.

For the convenience of the unit chiefs the azimuths of adjoining photographs along the line of flight should be established and inked on the field photographs. This will facilitate orienting the photographs properly for stereoscopic study in the field.

Where nine-lens photographs are to be used on planetables, they should be trimmed to fit the planetable boards and to facilitate handling. This may be done by centering a templet of clear acetate sheeting the size of the planetable over the working area of the photograph. Because photograph coverage is practically never symmetrical with the map layout, many of the photographs will not be cut symmetrically about their centers, therefore each print should be trimmed only after its usage has been determined and the net working area inked. The edges of the trimmed nine-lens photographs should be reinforced by a border of 1½- or 2-inch gummed paper tape on the back of the photographs.

When a nine-lens field photograph is trimmed, the photograph number must be replaced. Each nine-lens photograph is identified by stamping its number in the four corners on the face of the photograph—all numbers oriented to be read when the south side of the photograph is toward the user. The map number shall be stamped on the face of the photograph in the middle of the northern edge. Red fountain pen ink used on a stamp is satisfactory. The ink will adhere better to the photographs if spaces are erased with a pencil eraser before the numbers are stamped. A numbering stamp that has had an alphabet strip substituted for the last number strip is convenient.

Photo No	Print No	of	.
Date	Time		.
Tide Mean Range			
Stage		above MLW	
For map No (s)			.
Field Work by			.
( ) Recovery	( ) F Insp		
( ) Levels	( ) Topo	( )	
Started	Completed		
Examined and Approved			

FIGURE 1 21 —Field data stamp

The stamp in figure 1 21 is stamped on the middle of the back of each photograph by the Washington Office with the date and time information supplied, other pertinent information is to be supplied by the field party. When field data are recorded on more than one print of a particular photograph, the first print is designated "1," the second "2," etc., and the number of prints of that photograph on which field data are recorded is indicated on

the first line of the field data record (figure 1 21), as for example, "Photo No 11748-2, print No 2 of 3" When two or more prints of a field photograph are issued but data are recorded on only one, the extra prints are not designated as stated above

### 158 ADEQUACY OF PHOTOGRAPHY

General specifications for aerial photography are given in chapter 2, and the laboratory processes are mentioned

The Washington Office inspects the photograph coverage for its adequacy and the photographs for developing and printing imperfections Supplemental instructions will be written for additional photography to take care of any known deficiencies Photographs that do not conform to the specifications will generally only be furnished when they are sufficiently satisfactory for their proposed use

Any imperfections in the photographs or photograph coverage that will adversely affect the field or office compilation of maps should be reported to the Washington Office, however, it must be understood that the ideal from the view of the photogrammetrist cannot always be obtained, and consequently, imperfections in the photography must occasionally be compensated by extra work by the field parties or in the photogrammetric office

### 159 CONTROL PLANNING

*Control* is a collective term for a system of marks or objects on the earth whose horizontal positions and/or elevations have been determined A *control point* is the image on a photograph, or the mark or symbol on a map, corresponding to a *control station* which is a specific mark or object on the ground whose position and/or elevation has been determined or is to be determined

Table 1 4 shows the relation of the various control terms Each term has a meaning which excludes all other terms in the same vertical column Generally the terms are classified with respect to the method used for determining the position or elevation "Station" and "point" have restrictive meanings—the former is an object or mark on the ground, and the latter is an image, mark, or point on a photograph or map Therefore, for each station there is a corresponding point

A triangulation station is an object, whose geographic position has been determined by angular methods with geodetic instruments It must be located with first-, second-, or third-order accuracy (see pp 1 to 5, Special Publication No 145) A triangulation station may be especially marked or monumented or it may be a conspicuous natural or man-made object

A traverse station differs from a triangulation station principally in that its position is determined from another known point by linear measurements controlled in azimuth by angular measurements, instead of by angular methods solely

A topographic station is a definite object on the surface of the earth, whose geographic position has been determined by graphic methods, usually by planetable or photogrammetric methods

Classed also as topographic stations are those located by geodetic methods *but with less than third-order accuracy*, as stations located by (a) theodolite three-point fix without a check angle, (b) unclosed traverse, (c) a combination of traverse and triangulation, (d) any method that depends in part on floating or movable objects, (e) any method that depends on solar azimuths and (f) no-check intersection stations when the methods of observation do not indicate third-order or higher accuracy

Table 14—Classification of control

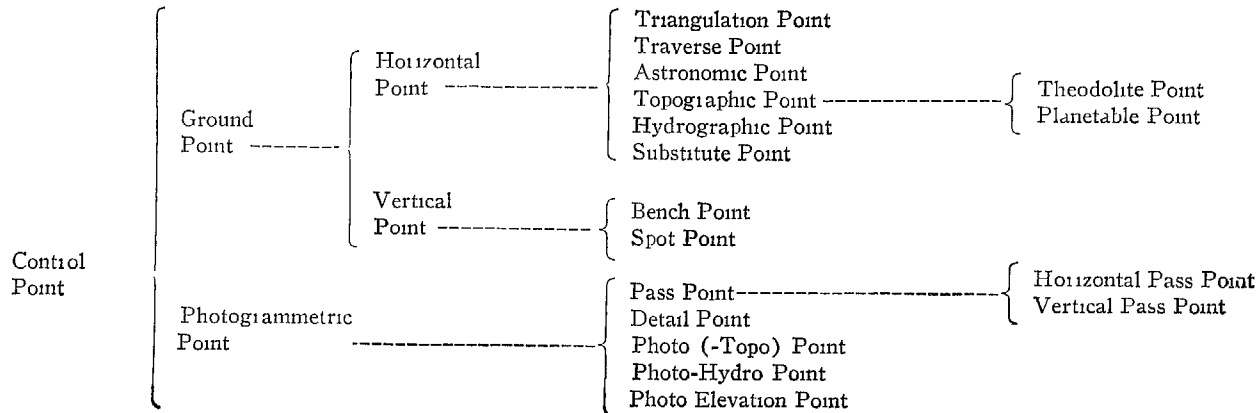
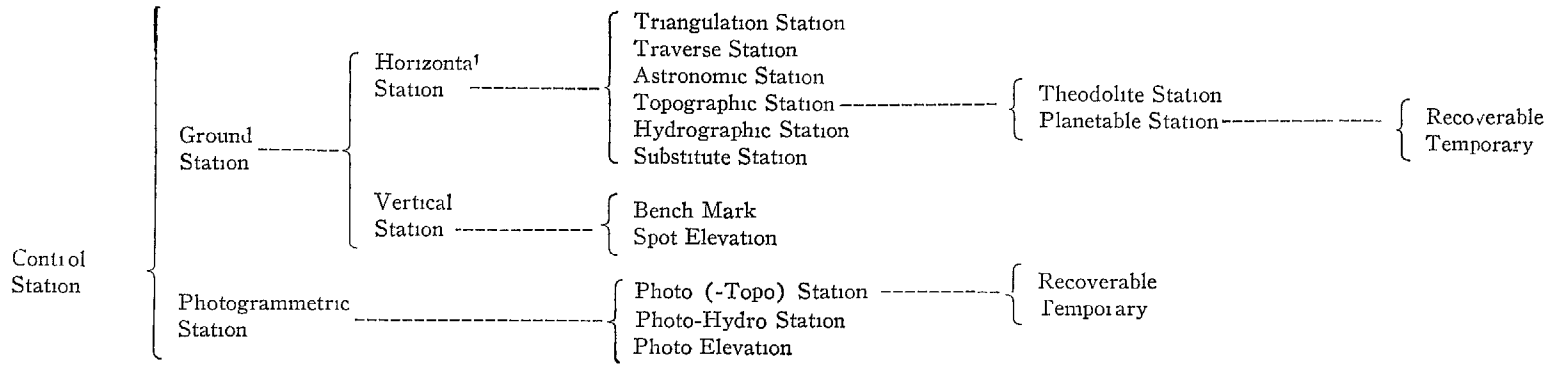

A topographic station may be recoverable, if it is marked by a standard station mark or is a conspicuous natural or artificial object, or it may be temporary

Descriptions are written of recoverable topographic stations

Control stations constitute the framework on which a map compiled from aerial photographs is fixed in its correct geographic position, azimuth, level datum, and scale with reference to the earth. Before the location and establishment of this control can be adequately planned, the Coast and Geodetic Survey requirements for control must be known and understood. Therefore, the purpose of the following headings is to state in general terms the control requirements for mapping by photogrammetric and field methods so that the accuracy of the completed maps meets the accuracy requirements of the Coast and Geodetic Survey and the National Standards of Map Accuracy.

The control station requirements within a project vary considerably, depending on the map specifications, the photogrammetric plotting method, and the terrain. In general the number of control stations required increases as the accuracy of the map is increased.

The control requirements for a mapping project are usually determined in the Washington Office, but in some cases the project instructions may specify that the control requirements be planned in the photogrammetric office. Regardless of how carefully the control is planned prior to beginning the surveys, some changes are usually necessary as the work progresses. Often several control stations can be established more economically in practical locations favorable to surveying than one station can be established in a location most favorable to theoretical photogrammetry. Thus, after field work has been started, the field party and photogrammetric office must cooperate fully in making such adjustments to control plans as will promote the highest possible efficiency in field work in keeping with the accuracy standards. This cooperation is necessary since field conditions will never be quite the same as they are visualized when the work is originally planned in the office.

The Washington Office forwards the necessary layouts, specifications, positions and descriptions of control, and indexes to the field parties with the project instructions. Vertical and horizontal stations just beyond the project limits may be used in controlling the photography or in establishing additional control and will be furnished with the control data for the project. These data are intended to be complete, but they should be carefully checked for completeness and the Washington Office should be informed of any deficiency.

### *1591 Horizontal Control Requirements for Hand-Templet Radial Plots*

Minimum ground control requirements for photogrammetric mapping are discussed under subsequent headings. These requirements are stated in general terms, for many variations are usually possible in planning the control for a specific project. Therefore, the requirements as stated herein are neither the bare minimum that might be acceptable in extreme circumstances nor do they represent the desirable number of stations where control is plentiful.

In the following discussion of requirements, the term "control stations" should be interpreted as meaning "*stations exactly identified on the aerial photographs*". This should be obvious but is sometimes overlooked.

For one strip of single-lens or nine-lens photographs not overlapped by adjacent strips, two stations—one on each side of the flight line, and preferably three to provide a fix—are needed at each end of the strip. These stations should be in the overlap of the first and second photograph at each end of the strip. Additional stations are needed along

the flight line so that at least one is within every third to fifth photograph along the flight, and three stations to provide a fix are desirable about every eighth or tenth photograph. The stations along the flight should be distributed so that alternate stations are on opposite sides of the flight line.

Control stations should not be close to the flight line. A control station close to the flight line fixes the azimuth but does not control the distance, or spacing, of the photographs along the line. Such a station will provide control for both the azimuth and distance only where it is nearly opposite the center of a photograph. A control station halfway between photograph centers should be distant from the flight line at least one-fourth the distance between photograph centers, otherwise, the intersections will be too flat.

Where it is impracticable to establish or to identify a needed control station, field parties should always try to provide single cuts or azimuths to features identified on the photographs. An azimuth observed from a known station to an object identified on the photographs provides control for the radial plot in one direction and a judicious use of azimuths often will compensate for an omitted control station. Azimuths normal to the flight line control the distance or spacing of photographs along the flight and those parallel to the flight line control the azimuth of the plot. This use of azimuths also applies to radial plotting with mechanical templates.

In planning control for larger areas involving several parallel flight strips, the outer strips require about the same control as a single flight strip does. The ends of alternate strips should be controlled by one or two stations and, throughout the radial-plot area, alternate strips should be controlled by one station every five or six photographs along the flight line.

Three-point fixes for certain photographs in a flight strip have purposely been omitted as a requirement. Such fixes are not essential, but they are desirable, and where a plethora of control exists they should be provided at the ends of flight strips where two stations are called for in the preceding paragraphs, and occasionally along flight strips, about every eighth to tenth photograph. For an areal plot all control stations except those in the outer strips should preferably be in the overlap between flight strips.

Where the coastline is very irregular, and particularly where many off-lying islands are to be mapped, the preceding specifications must be qualified, in fact, no theoretical requirements are likely to be adequate. However, the following facts may be helpful in planning control for such areas.

(a) Where the center of a photograph is in the water, the radial plot cannot be carried through that photograph and the flight line must be considered as broken into segments, each segment will require control as discussed in preceding paragraphs. Where the center of a photograph is in water very close to land, it may be considered an exception to the general statement.

(b) A balanced radial plot requires pass points on both sides of the flight line. Where most of one side of a flight line is over water for any appreciable distance additional control will be necessary to strengthen the plot.

(c) Where a relatively small isolated island is covered by two or three photographs in a strip, a minimum of three control points should be provided. Theoretically, the plot of two or three photographs can be based on two stations, but a third is needed as a check. Occasionally, a small isolated island is covered by a single photograph. Such a photograph can be rectified and used to compile details accurately in one datum plane, as, for example, the shoreline, but this requires a minimum of three control points whose horizontal positions and elevations are known, and these must not be on a line with one another.

The horizontal control requirements are the same for hand-templet radial plots for single-lens and nine-lens photographs, but the areal density of the stations is hardly comparable because of the difference in size of the photographs.

*1592 Horizontal Control Requirements for Mechanical-Templet Radial Plots*

Mechanical templets are almost never used in radial plots of nine-lens photographs because the extremely long arms of the spider templets tend to bend, and with slotted templets the studs tend to cut into the sides of the slots and to bind the templets. Therefore this discussion applies only to single-lens photography.

Mechanical templets are most advantageous in radial plots of areas covered by parallel flight strips with satisfactory forward and side lap. Generally it is not practicable to use mechanical templets in plotting single flight strips or where adjacent strips do not allow the pricking of pass points in the common overlap between flights. For single strips the same number of horizontal stations is required for hand-templet and mechanical-templet radial plotting, but a more logical adjustment can be made with hand templets.

A mechanical-templet plot is sufficiently rigid only within the area bounded by control, thus there should be horizontal stations at the limits or just outside the limits of the radial-plot area. This horizontal control should be supplemented by a sufficient number of horizontal stations within these limits so that the assembled templet plot cannot be moved appreciably.

For a mechanical-templet plot of single-lens photography where the area is covered with parallel flight strips of adequate overlap the minimum requirements for control are: The periphery of the area must be controlled by a horizontal station in the end or next to the end photograph of every other flight strip and by a horizontal station in about every fifth photograph in the two outer flight strips. The interior is adequately controlled by a horizontal station in about every sixth to eighth photograph of each alternate flight strip. For a mechanical-templet plot all control stations except those in the outer flight strips should preferably be in the overlap between flight strips.

*1593 Horizontal Control Requirements for Multiplex Bridging*

With the multiplex, photographs are plotted and compiled in single flight strips of six or more photographs per strip or unit, depending on the length of the multiplex bar and the number of projectors available. One horizontal station is required in the overlap area of both the first pair and the last pair of photographs of multiplex strips, however, two stations are preferable.

In general, multiplex bridging between horizontal ground control stations should not exceed eight to ten photographs or projectors. In some instances, as illustrated in figure 1 22, the establishment of additional ground control can be avoided by taking cross strips of photographs between the existing control stations. These cross strips are then bridged on the multiplex and points are established to control the main strips of photographs. In figure 1 22, each of the long parallel strips of photographs must be bridged in three sections of eight to ten photographs each, thus requiring additional traverse or triangulation. In this case the additional control will not be required if two cross strips of photographs are taken as illustrated.

Occasionally, when the cost of establishing control is high or the area to be mapped is relatively unimportant, it is justifiable to leave an inner strip partly controlled where it is between controlled strips.

To compile maps with well-defined points of detail located within 0.5 mm (0.02 inch) of their true position at the scale of the map manuscript (not the multiplex instrument sheet), the multiplex strip should not exceed eight to ten projectors between horizontal stations.



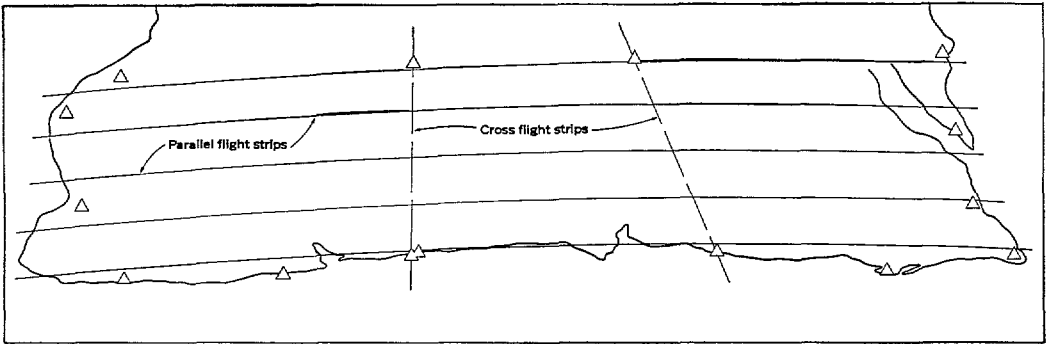

FIGURE 1 22—Bridging with cross flights to control intermediate multiplex strips

Occasionally, a well-controlled mechanical templet plot is used to break down the horizontal control and to provide horizontal pass points for the multiplex, but this is not general practice for mapping of standard accuracy and shall not be done without authority from the Washington Office

Along irregular coastlines with many off-lying islands the water areas are often so large and so distributed as to make impracticable the orientation of multiplex models, or for that matter, radial plots with single-lens photographs. Such areas require additional control and are sometimes compiled from a combination of single-lens compilation and planetable surveys.

#### 1594 Vertical Control Requirements for Planetable Contouring on Photographs

The extent of spirit or trigonometric leveling required prior to planetable contouring directly on photographs depends on the type of terrain and on the experience of the personnel of the topographic party. To determine the elevations of points which may be used as starting points for the planetable, the level lines should be run along roads and railroads within the project area and along those that lie most nearly along project and map limits. Elevations are determined of points that can be positively identified on the photographs. The locations and elevations of the points are clearly indicated on the photographs in permanent ink.

A level line should not be duplicated along the adjoining map limits, wherever possible, it should be run for common use on adjoining maps.

The line spacing generally does not need to be closer than  $1\frac{1}{2}$  miles, but the topographer should space the lines in the interior of a map where they will be of most advantage in the contouring. The identifiable elevations should be established along the level lines at about half-mile intervals or as frequently as is required for the most economical progress of the work of the topographer. The frequency often depends on the type of terrain—for example, where there are steep hills and ravines—and on the availability of well-defined points on the photograph.

In flat terrain where contours are widely spaced, economy can be gained when contouring by planetable by spacing the level lines somewhat closer and by determining elevations every third or quarter mile along each line, such a close network of elevations allows the planetable man to restrict his operations to the vicinity of each contour—he can follow each contour instead of making a complete survey of an area.

*1595 Vertical Control Requirements for Multiplex Contouring*

For accurate contouring by multiplex, a vertical station that can be positively identified on the photographs is required in each of the four corners of each stereoscopic model. In ideal photography a point in the corner of one photograph should also be in the corners of three other overlapping photographs and in the middle of the sides of two other photographs. Therefore, the theoretical minimum number of elevations for a large area is slightly more than one per model. This theoretical minimum must be increased, however, where there is improper "stagger" of the photographs in the adjoining flights, crab of the camera, or insufficient overlap, any one of these may require the establishment of control for each model independent of adjoining models.

Because of unfavorable field conditions, it is occasionally expedient to determine elevations of stations in only three of the four corners of a model, however, this is poor practice inasmuch as the multiplex operator's difficulties are increased and the probable accuracy is decreased. Where elevations are bridged in multiplex work, the accuracy decreases rapidly.

The placement of the vertical stations for multiplex mapping is critical, and each station must be at or near the point selected on the photographs. There is not the same great latitude of choice as there is in mapping with the Reading Plotter. Indexes showing the required elevations are prepared by either the Washington Office or the photogrammetric office and are forwarded to the field party. Any substituted control point must fulfill the minimum requirements for multiplex control.

Since level lines or trigonometric levels have to be run to the points specified for vertical stations (many of which are at some distance from accessible roads or railroads), additional elevations should be identified along the lines where little extra work is involved, especially where they will strengthen the control of a model.

*1596 Vertical Control Requirements for Contouring with the Reading Plotter*

The density and placement of vertical control for contouring from nine-lens photographs with the Reading Plotter can be stated only in the most general terms. The exact placement of stations is not so critical as with smaller photographs. The required density of vertical control depends to a considerable degree on the exactness with which the nine-lens camera can be calibrated. The recently established Ohio Calibration Area, mentioned in chapter 6, permits a more exact calibration than was previously possible and this will undoubtedly result in a decrease in the number of vertical control stations needed.

For 10-foot or 20-foot contour intervals in developed areas, lines of levels are usually run approximately along each flight line, and also about halfway between and parallel to flight lines. Elevations are established and identified on the photographs at about 1-mile intervals along these lines.

For 50-foot or 100-foot contour intervals in rugged terrain, an elevation is required about every 3 to 4 miles throughout the area to be contoured. These elevations should be distributed so that some are on the higher terrain and some in the lower parts. The water surface provides adequate vertical control along tidal shorelines.

## CHAPTER 2. AERIAL PHOTOGRAPHY

### 21 GENERAL STATEMENT

This chapter describes the equipment, methods, and procedures for aerial photography for large-scale coastal mapping. The subject is treated in general terms for the information of Bureau personnel using photographs. This chapter is neither a treatise on the intricate subject of aerial photography nor an operating manual for flight crews or laboratory technicians. Specific and detailed instructions are provided for operating personnel in the form of project or special instructions as needed.

Aerial photography and photogrammetry—the science of making measurements from photographs—have developed into a major industry since World War I, and photographs are now used in some manner in practically all mapping. Many types of maps are necessary in a diverse industrial civilization and aerial photographic equipment has been developed to meet the needs of each specific type of mapping. No one type of aerial camera or photogrammetric equipment is adequate for all mapping purposes. The nine-lens camera of the Coast and Geodetic Survey was designed specifically for large-scale coastal mapping, but other cameras are also used by the Bureau.

Aerial photographs for mapping must be taken with proper equipment and in such manner as to meet the requirements of the specific type of map. The cost of aerial photography is generally only about two percent of the total cost of producing a map. Consequently, it is nearly always more economical to take new photographs than to attempt to use existing photographs that are not exactly suitable for the purpose because of either age or type. This fact is often misunderstood but is supported conclusively by the experience and cost analyses of mapping agencies over a period of years. For example, normal-angle photographs taken for land use studies or other purposes are generally not suitable for stereoscopic contouring and the cost of new photography with the proper type of camera is saved many times over by the reduction in cost of ground control surveys. Furthermore, when photographs of the proper type are several years old, new photographs may cost less than the ground surveys required to map new features which do not appear on the older photographs.

Aerial photographs taken by the Coast and Geodetic Survey are distributed to other federal agencies, State and local governments, and private organizations and individuals at the cost of reproduction insofar as the laboratory facilities of the Bureau permit. Photographs of classified areas cannot be furnished without specific authorization from the National Military Establishment in each instance. Either contact prints or ratio prints are furnished from single-lens negatives, but nine-lens prints are furnished at the original negative scale only. Information concerning prices and availability of photographs can be obtained from the Director, U. S. Coast and Geodetic Survey, Washington 25, D. C.

#### 211 COAST AND GEODETIC SURVEY USE OF AERIAL PHOTOGRAPHS

Aerial photographs are used by the Bureau in producing accurate large-scale base maps of the coastline as required for nautical charting, in revising nautical charts, in compiling and revising aeronautical Instrument Approach and Landing Charts and Airport Obstruction Plans, and for triangulation reconnaissance in Alaska.

##### *2111 Coastal Mapping*

Accurate large-scale base maps of the coasts of the United States and its possessions are compiled from vertical aerial photographs supplemented by ground surveys. These

may be topographic, planimetric, or shoreline maps as described in 15. Most of the aerial photographs for this mapping are taken with the nine-lens camera at scale 1 10,000 or 1 20,000, although 1 30,000 scale photographs are used in some parts of Alaska. Single-lens photographs at contact scales from 1 5,000 to 1 40,000 are also used.

#### *2112 Nautical Chart Revision*

The shoreline and land details on nautical charts must be frequently revised because of continual changes in the coastline, and photographs of changeable areas are taken periodically for this purpose. Furthermore, photographic missions are constantly alert to notice natural or cultural changes along the coast and to photograph these areas for chart revision. It is neither practicable nor necessary to make new field surveys for each revision of a nautical chart. The maps mentioned in 2111 serve as base maps for revision purposes for a number of years before an area must be completely remapped, map details generally can be revised from the photographs in the office by holding to unchanged features on the base map, although limited field-inspection surveys are often necessary to clarify the photographic detail. Thus, nautical chart maintenance requires that the coast be adequately mapped at a comparatively large scale, and that it be remapped at intervals ranging from 5 to 20 years, depending on the frequency and magnitude of natural and cultural changes. In the interim, the charts are corrected from revision photographs and limited field inspection as often as necessary.

#### *2113 Airport Plans and Charts*

Aerial photographs are used in the production and maintenance of aeronautical Instrument Approach and Landing Charts and Airport Obstruction Plans. Obstructions and dangers to navigation are identified on the photographs in the field, and then practically all details shown on the charts and plans are compiled from the photographs in the office. Either nine-lens or single-lens photographs are used for this purpose.

#### *2114 Reconnaissance*

In parts of Alaska, where available maps are at small scales and are inadequate in many instances for either office planning or field surveys, nine-lens photographs are taken prior to any field work, and mosaics or preliminary planimetric maps are compiled from these for use in planning and executing triangulation and hydrography. For triangulation purposes, the mosaics are reproduced at scales of 1 60,000 to 1 100,000. These mosaics are based on uncontrolled or semicontrolled radial plots which serve to maintain a certain consistency in scale and orientation in the mosaics. Preliminary planimetric maps are often made to provide shoreline and other map information for use in hydrographic surveys or combined operations. Upon completion of the triangulation and field inspection of the photographs, the same nine-lens photographs are used in compiling accurate maps of the coast.

### **212 SEASON AND WEATHER**

Aerial photographs must be taken under optimum weather conditions when the visibility is high and the cloud coverage is 10 percent or less. Furthermore, the terrain must be comparatively free of snow, and photography of wooded areas must be taken when the trees are not in full leaf. In continental United States, aerial photography is generally limited to that time of day when the solar altitude is not less than 30° so that the light is

bright enough for proper exposure and so that the shadows are not inconveniently long. Dark shadows on steep slopes or bluffs can completely obscure details on the photographs. The duration of the acceptable solar altitude for photography varies with the season and the latitude, but the most suitable time for photography is often limited to 4 to 6 hours per day.

### *2121 Weather*

Weather is the most important single factor in aerial photography and photography should be planned to take advantage of the best seasonal conditions in any given locality. An exhaustive study of Weather Bureau records for a 37-year period was made by the Agricultural Adjustment Administration of the Department of Agriculture, and it was found that favorable weather for aerial photography varied from an average of 3 days per month in northeastern United States to 15 days or more in southwestern United States. These findings are recorded on a map of the United States which shows graphically the average number of days per month in which weather suitable for aerial photography can be expected in any part of the country. This map and a supplemental table showing weather variations from month to month are available for use in planning aerial photography. The map is reproduced as figure 21 by courtesy of the Department of Agriculture.

### *2122 Photography in Alaska*

Aerial photography is particularly difficult in Alaska because of the prevalent bad weather, and in some areas—the Aleutian Islands, for example—suitable weather is a great rarity. Because of the high latitude the desirable solar altitude for photography is limited to a few weeks in the summer season. This condition is further aggravated by the fact that most of the coastline is precipitous and photographs of it must be taken when the sun is relatively high or the shoreline is obscured by shadows.

Because suitable weather is so infrequent, the requirement for continental United States that photography must be taken when the solar altitude is more than 30° must be relaxed, and photographs are taken whenever the light intensity will permit. Shadows on northern slopes are sometimes reduced by taking the photographs under a light overcast, but this restricts the altitude of the photography and is only occasionally practicable.

Weather reporting facilities are comparatively meager and forecasting for photography is difficult. This factor and the scarcity of suitable airplane servicing and base facilities make it imperative that long-range airplanes be used for aerial photography. A PB-1G (B-17) airplane furnished by the Coast Guard is used for all Coast and Geodetic Survey aerial photography (see also 231).

The nine-lens camera is particularly advantageous for coastal mapping in Alaska because it provides the greatest coverage at a large scale in the extremely limited time available for aerial photography.

## 22 CAMERAS AND MATERIALS

An aerial mapping camera is an intricate instrument designed for a specific purpose and differs radically from cameras made for press photography, portraiture, reproduction, or other uses.

For mapping purposes the perspective of light rays entering the camera lens must be reproduced in the camera without distortion, or the distortion must be exactly known and compensated for in the subsequent map compilation procedures. Therefore, the lens must

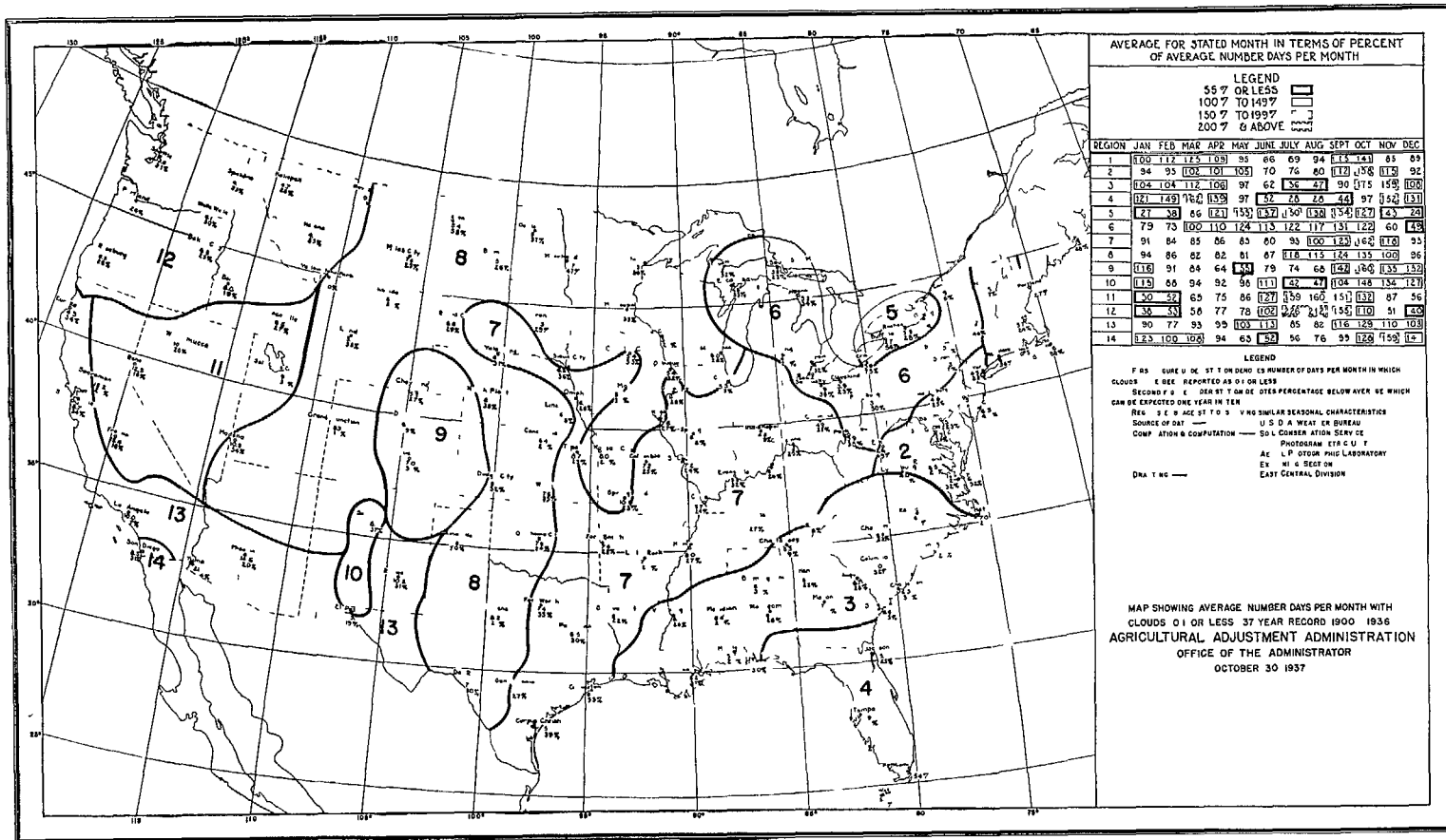

Figure 2.1 — Weather map

have high resolution and minimum distortion, and the camera must be accurately and rigidly built to withstand the vibration and temperature changes encountered in operation. The lens is usually mounted at a fixed distance from the film, where it is focused for best average resolution of distant details throughout the film area. The lens is tested photographically in several positions before it is finally mounted. The construction of single-lens and multiple-lens mapping cameras is discussed in some detail in **2222** and **2232**. For best results the camera is electrically operated and exposures are made automatically at any selected time interval. An aerial camera is equipped with an exposure counter and level indicator, and it is mounted in such a way that it can be rotated to compensate for crab, and leveled in two directions at each exposure. Shutters are of the between-the-lens type which exposes the entire film area simultaneously. In multiple-lens cameras the shutters must be exactly synchronized for simultaneous exposure.

Roll film is generally used in lengths that permit many exposures on one roll, and most cameras are equipped with interchangeable film holders so that film rolls can be changed in the air. Much effort has been devoted to reducing film distortion, but it is perhaps the weakest link in the entire photogrammetric procedure. Film is used in this country for reasons of economy and convenience but in several European countries there is a tendency to revert to plate cameras for aerial photography to be used in the most accurate large-scale mapping, particularly where control is to be "bridged" on precise stereoscopic plotting instruments.

## 221 LENS REQUIREMENTS

The most important characteristics of lenses for aerial mapping cameras are (a) *high resolving power*, (b) *relatively large aperture*, (c) *low distortion*, (d) *flat image field*, (e) *wide angular coverage* (f) *color correction*. Some of the characteristics tend to be mutually exclusive and in the best lenses so far designed no one characteristic is fully attained without some sacrifice in others. Consequently, the design of a lens is usually a compromise between the several desirable factors.

(a) *High resolving power* is essential to provide sharply defined images of natural and cultural features at relatively small scales so that these features can be correctly identified and mapped. This is more difficult to attain in an aerial lens because of the large aperture required and the relatively wide field of view.

(b) *Relatively large apertures* are essential because of the short exposure required—the airplane is generally moving at a speed of more than 100 miles per hour and short exposure intervals are necessary to avoid blurred images due to movement of the airplane and vibration of the camera.

(c) *Low distortion* is necessary in order to retain the true perspective mentioned in **22**. Unfortunately, this fact limits the angular field of the lens since distortion increases and resolution decreases as the field of view is enlarged.

(d) *Flat image field*. The lens must focus all details on a plane surface in order to retain the correct perspective and to give sharp images throughout the whole photograph. As the angular coverage of a lens is increased it becomes more difficult to focus images in one plane.

(e) *Wide angular field*. The cost of photogrammetric mapping is generally directly proportional to the number of photographs required to cover an area, consequently, photogrammetrists have tried for many years to get the field of view increased in mapping cameras. This has been attempted in two ways, by increasing the field of view of a single-lens camera, and by using multiple-lens cameras. The present *wide-angle* lens of

the "metrogon" type with an angular field of about  $93^\circ$  represents a workable compromise in lens design, wherein the resolution is somewhat less and the distortion is greater than in a normal lens which has an angular field of about  $60^\circ$ . The amount of distortion in a wide-angle lens is not sufficient to affect planimetric mapping but does affect stereoscopic contouring and is compensated for at some stage in the office procedures. For some uses compensation is attained through the lens of the diapositive printer, and in some instruments the photograph is projected through a lens of similar distortion characteristics, and in others the principal distance of the plotting instrument projectors is varied in accordance with the distortion characteristics of the aerial lens.

(f) *Color correction* An aerial lens must be corrected for chromatic aberration, that is, it must focus all colors in the same plane to attain good resolution of details.

## 222 SINGLE-LENS CAMERAS

The single-lens cameras owned by the Bureau and those of other agencies whose photographs are used by the Bureau for coastal mapping are discussed in this section. For large-scale mapping purposes, single-lens cameras may be divided into two general classes, (1) the K-17 type with interchangeable lens cones discussed in **2221**, and (2) the precision type designed particularly for stereoscopic contouring. Several different types of precision cameras are manufactured in the United States, one of which is the Fairchild Cartographic Camera described in **2222**.

The Coast and Geodetic Survey uses the following single-lens cameras

K-17 camera with 6-inch and 12-inch cones (see **2221**)

Fairchild Cartographic (precision camera with 6-inch metrogon lens) (see **2222**)

Fairchild F-51 (precision camera with 6-inch metrogon lens) (see **2223**)

K-20 cameras (see **2224**)

The K-17 camera is used for mapping by graphic methods and for chart revision purposes. The cartographic camera is used for photography to be used for stereoscopic contouring with the multiplex or stereoplanigraph and for other general purposes. The F-51 camera has been superseded by the cartographic camera except for purposes involving the special grid discussed in **2223**.

### 2221 K-17 Camera

The K-17 camera manufactured by the Fairchild Camera and Instrument Corporation has been widely used for mapping in recent years and was the standard military mapping camera during the war (see fig 22). The camera is electrically operated and fully automatic. It is of proved mechanical design and construction, and is an excellent general purpose mapping camera applicable to most mapping, with the possible exception of accurate stereoscopic contouring. The K-17 camera is built to use interchangeable lens cones of different focal lengths. It takes standard 9- by 9-inch photographs and the film magazines are interchangeable so that it can be loaded in the air. The usual magazine capacity is 250 exposures but the manufacturer can supply a magazine with a capacity of approximately 500 exposures.

The camera is accurately constructed but, because the fiducial marks are on the film magazines and the lens cones are interchangeable, the focal distance and the relationship between the lens axis and the fiducial marks are not maintained so exactly as in the "precision" cameras, such as the Fairchild Cartographic Camera discussed in **2222**.



The Coast and Geodetic Survey operates K-17 cameras with 6-inch and 12-inch cones. The 6-inch lens is a "Metrogon" and is generally used for planimetric mapping and revision surveys in open areas where the compilation scale is 1:20,000 or smaller. The 12-inch lens is an "Aerostigmat" of superb resolution and is used for large-scale planimetric mapping of congested areas, as in harbors, where definition of detail is extremely important and where ground control is generally abundant.

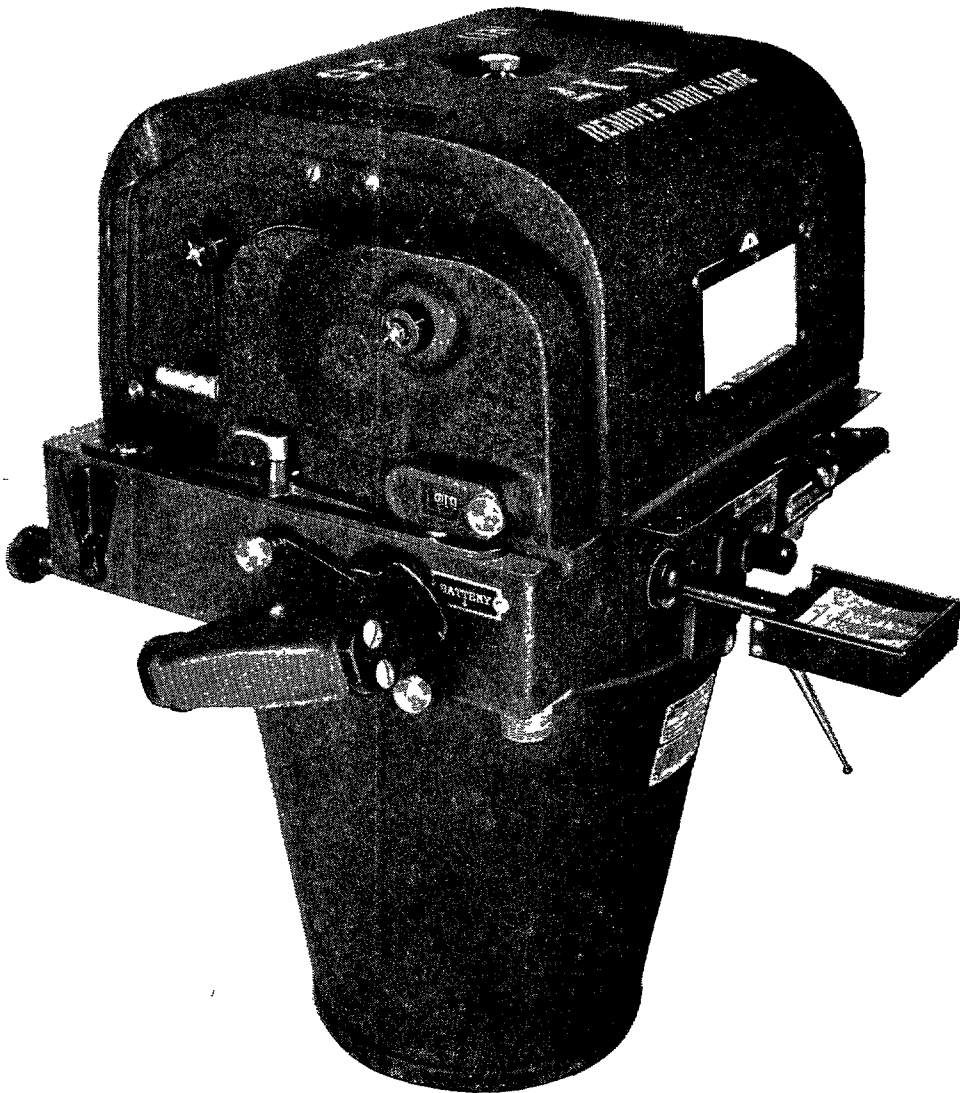

FIGURE 22 —K-17 camera with 12 inch lens

*2222 The Fairchild "Cartographic" Camera*

The Fairchild "cartographic" camera was developed from the basic design of the K-17, with modifications which make it a "precision" camera in all respects

The outstanding precision features are

(a) The lens and the film plane are mounted on one casting, known as the "inner cone" This inner cone is mounted inside the camera body but is a separate part and, if the camera is disassembled, the lens and film plane are undisturbed

(b) The axis of the lens is fixed in a position exactly perpendicular to the film plane and its intersection with the film plane (principal point) is indicated by the intersection of lines connecting fiducial marks on the edge of the film frame

(c) The fiducial marks, which are in the film plane, are secured to the inner cone and their relationship to the lens is therefore not disturbed when the camera is disassembled

(d) Lines drawn to connect opposite fiducial marks intersect at an angle of  $90^\circ$  plus or minus 1 minute and they indicate the position of the principal point with a probable error not exceeding 0.0005 inch

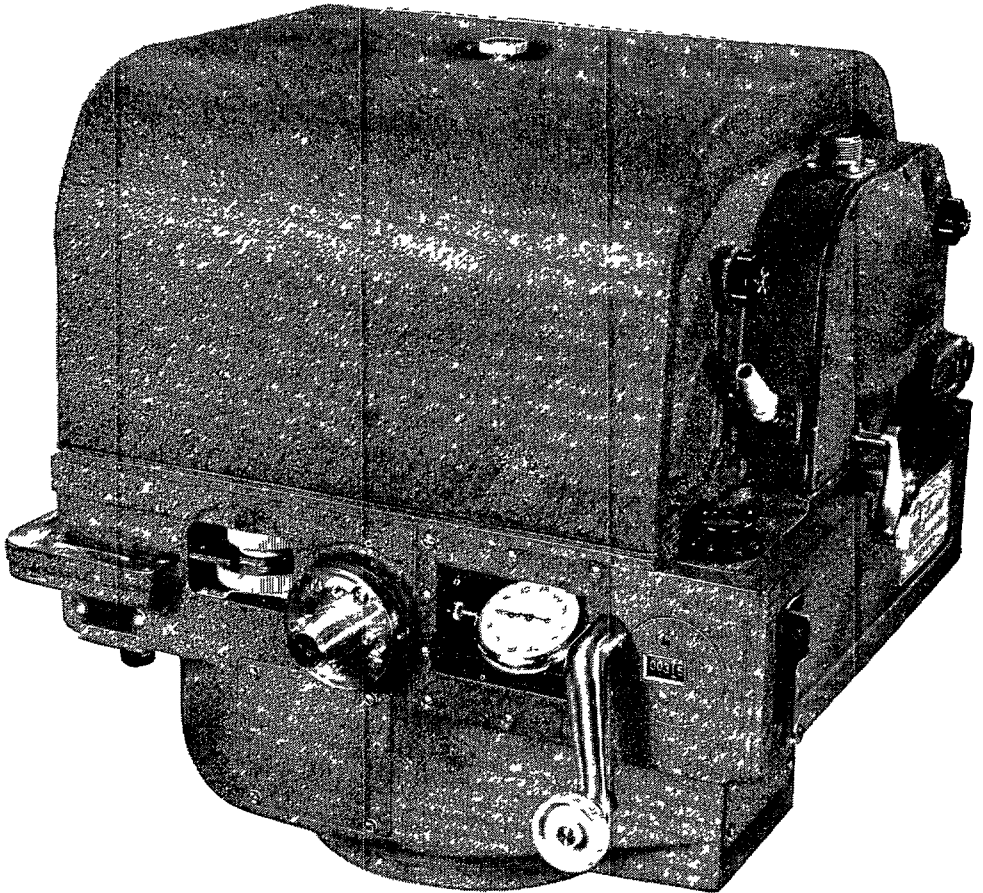

FIGURE 23 —Fairchild cartographic camera

(e) The focal plane is determined by the machined surfaces of the four fiducial marks that are securely screwed and doweled to the edges of the inner cone. The film moves between the focal plane and a vacuum back in the magazine. This back is a casting whose surface is machined flat within 0.0005 inch. At the instant of exposure the film is held flat against the back by vacuum and forced against the fiducial marks, so that it is exactly placed in the focal plane at this instant. After exposure the vacuum ceases and the pressure of the vacuum back is released to permit the film to move freely. The vacuum back casting is specially heat-treated and has deep ribs on the back to keep it flat in spite of the stresses caused by temperature changes and normal operation.

(f) The between-the-lens shutter can be removed for cleaning and adjustment without removing the lens elements from the inner cone.

Roll film is used to take 9- by 9-inch photographs. It is loaded in interchangeable magazines, each with a capacity of 250 exposures. One of the principal differences between this camera and the K-17 camera is that the fiducial marks in the "cartographic" camera are rigidly attached to the inner cone and are independent of the magazine, whereas in the K-17 the fiducial marks are in the magazine and thus their relationship to the lens is not necessarily constant.

The manufacturer will supply this camera with any one of several lenses of different focal lengths. The one owned by the Coast and Geodetic Survey is equipped with a Bausch and Lomb metrogon lens of 6-inch focal length. This camera is now used almost exclusively for single-lens mapping photography requiring a 6-inch lens. It is used for all photography for contouring by the multiplex or the stereoplanigraph and is often used for photography for use in mapping by graphic methods.

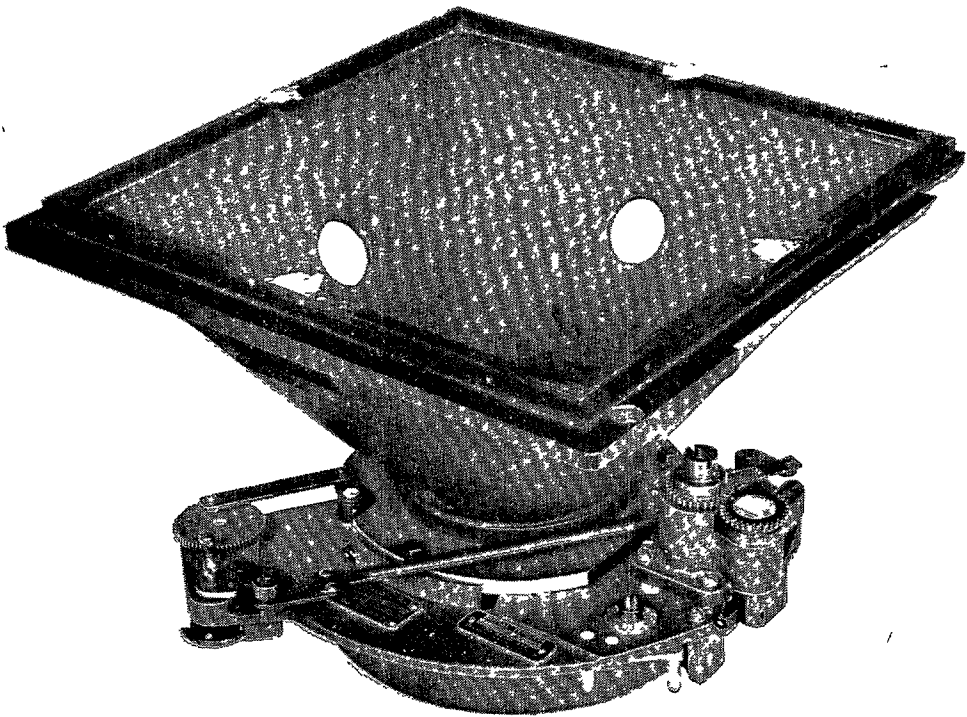

FIGURE 24—Inner cone of cartographic camera

*2223 F-51 Camera*

The F-51 camera was one of the first film aerial cameras built to meet the requirements for a precision camera. It is equipped with a 6-inch metrogon lens and can be loaded with 9½-inch film in rolls to take up to 400 exposures without reloading. It does not have interchangeable magazines. The camera of this type used by the Coast and Geodetic Survey has been modified by the addition of a ruled glass plate in front of the film at the focal plane which registers a rectangular grid or 'reseau' on the negative at every exposure. This reseau, accurately ruled at 1-centimeter intervals, permits measurement of coordinates on the film independently of film or paper distortion. This camera has been largely superseded for mapping purposes by the cartographic camera but it is used when coordinates are to be measured accurately as, for example, in research into the general and local effects of film distortion.

*2224 Cameras for Oblique Photography*

The use of oblique photographs by the Bureau is now limited to (1) Aerial obliques of harbor areas and of airports for special studies relative to landmarks for nautical charts and the charting of waterfront details, and to the selection and charting of obstructions to air navigation. (2) Terrestrial horizontal or near-horizontal photographs used in establishing vertical control in Alaska for use in stereoscopic contouring with vertical photographs, this use is experimental. The photographs are taken from ground stations with a phototheodolite or from shipboard with a hand-held K-20 camera. Aerial obliques can also be used for this purpose. (See 37)

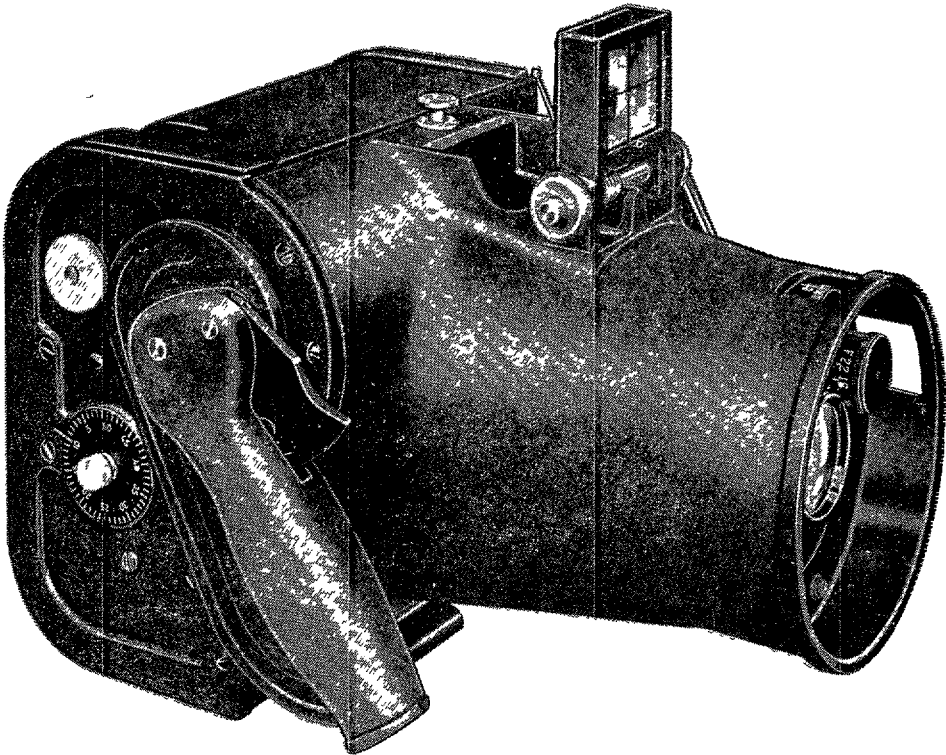

FIGURE 25 —K-20 camera

Aerial obliques, (1) above, are taken with the K-17 camera with either the 6-inch or 12-inch lens (see 2221) The horizontal or near horizontal photographs, (2) above, are taken with a phototheodolite or with the K-20 camera If results from the K-20 camera are promising and the methods are continued, a more "precise" camera will probably be purchased or built for the purpose

The K-20 camera (fig 25) takes 50 pictures, 4 by 5 inches in size, on a 20-foot roll of film Film is advanced and the shutter is rewound manually by advancing the winding handle forward through an arc of about 80° and returning it to its original position This camera is usually equipped with a 6¾-inch focal length  $f/4.5$  anastigmatic lens fixed to focus on distant objects The film is held flat at the moment of exposure by vacuum created by a spring-operated piston The lens is not calibrated, its focal length may vary appreciably from the value marked, and the position of the principal point is not indicated by fiducial marks or other means

## 223 THE NINE-LENS CAMERA

### 2231 Introduction

The nine-lens camera was designed by Captain O S Reading of the Bureau to meet the specific requirements of coastal mapping The principal objectives in the design were to obtain as great a coverage as practicable per photograph at the relatively large scales (1 10,000 to 1 20,000) required for detailed mapping of the coast and alongshore features

TABLE 2 1—Nine Lens Camera Data

Focal length 8.24 inches (209.7 mm), field 130° × 130° square  
 Net weight 306 pounds (140 kg), gross weight with all equipment for photography 750 pounds (340 kg)  
 Size of camera 29 inches (74 cm) wide, 27 inches (67 cm) fore and aft, 31 inches (79 cm) high  
 Size of film 23 inches (58 cm) by 200 feet (61 meters) (100 exposures plus leader)  
 Size of composite photographs 35.4 inches (90 cm) square

TABLE 2 2—Coverage Data

Scale	1 10,000	1 15,840	1 20,000	1 31,680
Width of strip				
Statute miles -----	5.6	8.8	11.2	17.7
(Kilometers) -----	(9.0)	(14.2)	(18.0)	(28.5)
Altitude above ground				
Feet -----	6,875	10,890	13,750	21,780
(Meters) -----	(2,095)	(3,319)	(4,191)	(6,639)
Area covered whole photo				
Sq statute miles -----	31.2	78.3	124	313
(Sq kilometers) -----	(80.8)	(202.8)	(321.1)	(810.7)
Area per photo overlapped				
80% × 60% Sq stat miles -----	2.5	6.3	10	25
(Sq kilometers) -----	(6.5)	(16.3)	(25.9)	(64.8)
80% × 30% Sq stat miles -----	4.4	10.9	17.5	44
(Sq kilometers) -----	(11.4)	(28.2)	(45.3)	(113.9)
60% × 60% Sq stat miles -----	5.0	12.5	20	50
(Sq kilometers) -----	(12.9)	(32.4)	(51.8)	(129.5)
60% × 30% Sq stat miles -----	8.7	21.9	35	88
(Sq kilometers) -----	(22.5)	(56.7)	(90.6)	(227.9)
66% × 33% Sq stat miles -----	7.0	17.8	28.5	71
(Sq kilometers) -----	(18.1)	(46.1)	(73.8)	(183.9)
Statute miles (kilometers) of strip per loading				
80% overlap -----	112	177	223	354
-----	(180.2)	(284.8)	(358.9)	(569.7)
66% overlap -----	190	300	380	602
-----	(305.8)	(482.8)	(611.6)	(968.8)
60% overlap -----	223	354	447	708
-----	(358.9)	(569.7)	(719.4)	(1139.4)

such as rocks, small piers, and aids to navigation. The camera is illustrated in figures 26 and 27, and pertinent data are given in tables 21 and 22.

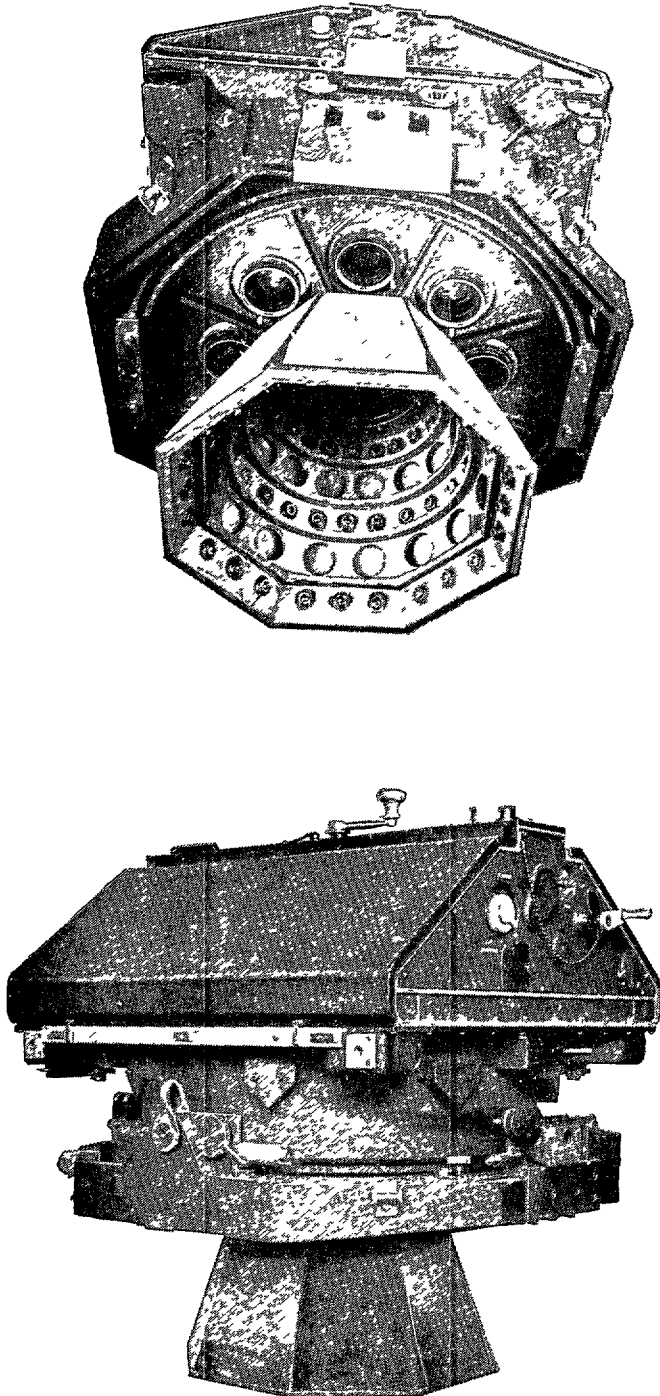

FIGURE 26—Nine lens camera

Large (wide-angle) photographs are especially advantageous for coastal mapping where the shoreline is broken and irregular with many indentations and off-lying islands, inasmuch as the water areas can be more readily spanned with large photographs and the ground control problem is thereby simplified. This fact has been recognized and multiple-lens cameras have been used since the inception of photogrammetry in coastal mapping. Three-, four-, and five-lens cameras were used prior to the nine-lens camera.

The design of the nine-lens camera and transforming printer was started in 1933. The camera and printer were manufactured by the Fairchild Aerial Camera Corporation of New York, the camera being delivered in 1935 and the transforming printer in January 1936.

The first test flight of the nine-lens camera was made at Wright Field, Dayton, Ohio, in November 1936. The camera operated satisfactorily and was used continually thereafter until the airplane carrying it crashed in 1943. The critical adjustments of the lenses and mirrors (see 2232) proved to be remarkably stable under flight conditions. The test flight and subsequent photography were made possible by the U. S. Army Air Force providing a B-10-B Martin bomber for this purpose. The bomb-bay doors were removed and a temporary plywood floor and a sliding hatch were installed for mounting the camera.

The first mapping project with the nine-lens camera covered about 1200 square miles in the northern Chesapeake Bay area, it was photographed in May 1937 at the scale of 1:10,000. This project is illustrative of the practical use of the camera for coastal mapping. The 1200 square miles to be compiled on 50 maps at the scale of 1:10,000 were covered by 380 photographs, overlapped 60 percent both along the flight and between the flight lines, or an average of 7.6 photographs per map.

A total of 323 7½-minute topographic quadrangles covering approximately 15,000 square miles were produced by the Coast and Geodetic Survey as part of the war mapping program, and practically all these were compiled from nine-lens photographs.

The camera has been used for photography of coastal areas continually since 1937, and has been particularly effective in Alaska where photographic weather and ground control are at a premium. In recent years it has been carried in a B-17 airplane provided by the Coast Guard.

The airplane carrying the nine-lens camera crashed on Adak Island in the Aleutian Islands, Alaska, in July 1943 with the loss of all but two members of the crew. However, the camera was salvaged and rebuilt by the Fairchild Camera and Instrument Corporation and was recommissioned in September 1945. Although the principal features of the design were unchanged, a number of improvements were made when the camera was rebuilt, the most important of these was the addition of 40 fiducial marks to facilitate the measurement and compensation of film distortion during transforming printing and the checking of the composite prints.

A rectifying camera and a stereoscopic plotting instrument for contouring from nine-lens photographs were designed by Captain Reading and built between 1938 and 1943. These instruments are described in chapter 6.

A special calibration area for nine-lens photographs was established near McClure, Ohio, in 1947. Photographs of this area are taken at the beginning and end of each season for use in testing and adjusting the mirrors and lenses as discussed in chapter 6. The area is a 5-mile square in which 80 accurately located and permanently monumented control stations have been established, each station being especially marked so as to be visible on the aerial photographs.

2232 *Description of the Nine-Lens Camera*

The nine lenses are arranged on a central mount with all axes parallel so that the nine separate images are exposed simultaneously on one piece of film. The wide coverage is obtained by combining a single vertical view from the central lens with oblique views taken through the other eight lenses which are arranged in an octagonal pattern about the central lens. The fields of the eight outer lenses are deflected  $38^\circ$  from the central axis by stainless steel mirrors secured on a hollow stainless steel cone in front of the lenses. In making a print, the aerial negative is placed in a special transforming printer and, by nine separate exposures on one piece of paper, the original relationship between central and wing chambers is reconstructed and the nine images are recombined to form a single composite print which has the geometrical characteristics of a single-lens photograph with an angular coverage of  $130^\circ$  and a focal length of 210 millimeters. Prints are 354 inches square.

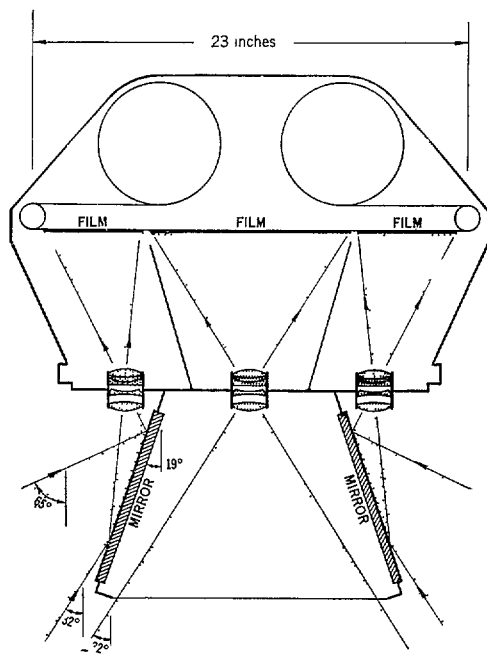

FIGURE 27 —Diagram of the nine lens camera

The mirrors of the camera are of stainless steel about  $5/16$ -inch thick, with reflecting surfaces of an evaporated metallic film. The mirrors are attached to the camera cone by means of nine tapped bolt holes in the back of each mirror. The body of the camera, the cone, the mirrors, and the nuts and bolts that hold the mirrors were all made from the same steel ingot, so as to equalize the effect of temperature changes. Careful measurements made before and after a season's operation have proved that this arrangement is highly stable and satisfactory.

Once each winter some of the mirrors are replaced by extra mirrors that have been resurfaced. The replacement of a mirror involves a series of accurate measurements and delicate adjustments that are performed at a special laboratory at Gaithersburg, Maryland. The adjustments involve setting optical collimators within tolerances of 5 seconds with a theodolite, adjusting the positions of lenses and mirrors within tolerances



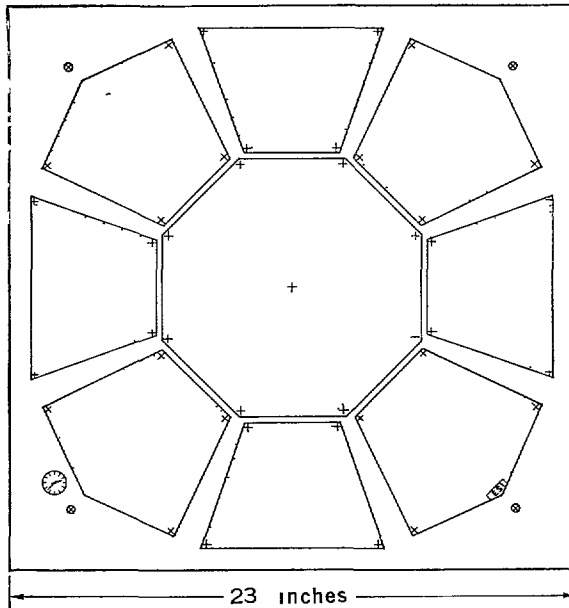

FIGURE 2 8 —Nine lens negative

of 0 001 inch as seen in a microscope, and flattening the mirrors within six wave lengths of light as seen with an interferometer arrangement. Whenever a mirror is replaced, the orientation and flatness of each of the other mirrors and the position of each lens are also checked and adjusted if necessary.

The mirrors of the camera are inclined  $19^\circ$  from the vertical so as to produce an oblique photograph having a tilt of  $38^\circ$ . The oblique views of the negative contain an overlap about  $\frac{1}{8}$ -inch wide all the way around so that, in printing, each view can be adjusted and masked to fit the other views without creating gaps. The separated exposures on the negative are not arranged as might at first be expected because (see fig 27) the rays of light from the lower left ( $32^\circ$ ) for the center octagon pass through the center lens and continue in the same general direction to the upper *right* side of the negative, whereas rays from this same bundle of light that form the edge of the oblique view are interrupted by a mirror and are reflected to the *left* side of the negative. Moreover, the oblique negative views are inverted relative to the center octagon because of the mirror reflection. The camera is provided with 45 fiducial marks that are projected onto the surface of the film at the instant of exposure by means of tiny targets, lenses, and lights. One cross marks the principal point, and one cross appears in the picture area at each of the four corners of the eight oblique views, in each of the eight corners of the center octagon, and outside the picture area in the four corners of the negative film.

The camera is suspended from a hand-operated crank hoist in the aircraft during take-offs and landings, but during photography a floor hatch is opened and the camera is lowered to a tiltable camera mount so that no part of the airplane obstructs the view. A viewfinder is attached to the camera and is used in determining and correcting for the crab of the airplane and for setting an intervalometer. The image of a traveling grid can be seen in the field of view of the viewfinder and the speed of the grid can be controlled so that the grid lines travel across the field at the same rate as images on the ground. Setting the speed of the grid also sets the intervalometer which automatically starts, at the proper

time intervals, a series of mechanical and electrical camera operations which include opening the lens shutters, releasing the film vacuum, winding and metering the film, and reapplying the film vacuum. The intervalometer also actuates lights on the camera, on the pilot's instrument panel, and on the navigator's instrument board for a period of 5 seconds before an exposure is made, ceasing at the moment of exposure. A second light on the camera flashes when the exposure is made to indicate that the shutters have operated, and a third light is illuminated as the film is being transported, and goes out when the proper amount of new film has moved into place. The vacuum is supplied by a pump run by an electric motor from the airplane's electric system. The camera lights and shutter solenoids are also operated from the plane's electric circuit. The camera is equipped with a visual vacuum gage that indicates the pressure on the film at the focal plane. Level bubbles are provided with which to level the camera in both directions.

The photographic airplane is equipped with a Norden bombsight, automatic pilot, astro-compass and flux gate compass to assist the navigator in flying straight courses during photography and in obtaining the proper forward and side laps. The aircraft in use at the present time is also equipped with radar and radio and manned with competent Coast Guard operators.

The transforming printer (fig 61) is the instrument by means of which the negative from the nine-lens aerial camera, consisting of one vertical and eight oblique photographs on one piece of film 23 inches square, is projected onto a single piece of photographic paper, to make a composite photograph 35 inches square. The resulting transformed photograph is equivalent geometrically to what might be taken with a single-lens camera whose angular field of view is equal to that of all nine lenses of the nine-lens camera ( $130^\circ$  by  $130^\circ$ ). The transforming printer is described in chapter 6.

## 224 THE TRIMETROGON CAMERA

The trimetrogon camera is a recent multiple-lens camera designed particularly for aerial photography for use in small-scale and reconnaissance mapping. It is not used in connection with large-scale coastal mapping but it is mentioned here because of its importance and because of the general interest regarding it. It is used principally for photography for use in aeronautical charts of previously unmapped areas. The development and use of this camera during World War II for rapid mapping of vast unmapped areas of the world as required in that war is one of the most interesting stories in photogrammetry or cartography. Over 15 million square miles were photographed in all parts of the globe during the war, and the trimetrogon system is still in extensive use for photography for use in the compilation of reconnaissance and other small-scale maps necessary for military preparedness. (See 92)

The trimetrogon camera consists of three K-17 cameras rigidly mounted together as a unit and operated as a single camera. One camera axis is vertical and the other two are at  $60^\circ$  right and left across the line of flight. The cameras are equipped with 6-inch metrogon-type lenses and the total field of view is  $180^\circ$ , that is, from horizon to horizon across the line of flight. The oblique photographs are not transformed, as with the nine-lens camera. Planimetry is compiled from these photographs by graphic methods, using special instruments designed for radial plotting and compiling from the oblique photographs. Contouring is done with the aid of the Wilson photoalidade. (See 37 and 921)

## 225. AERIAL PHOTOGRAPHIC FILM

Although many types of photographic films are available, only a very few are suitable for aerial photography and, to meet the needs of the photogrammetric operations of the Coast and Geodetic Survey, only a relatively high-speed, fine-grain, panchromatic film is used. Typical of this class is the super XX film manufactured by Eastman Kodak Company.

The mechanical limitations of photographing from an airplane flying at high speeds and the necessity for easy identification of all images in the photography, place rather stringent restrictions on color sensitivity, speed, and grain. Complete color sensitivity is required to render the correct tones of the landscape and to permit the use of filters to penetrate haze and in some cases to vary the contrasts between colored features. The film must be fairly fast in order to permit exposures between 1/100 and 1/250 of a second through filters and still obtain negatives of satisfactory density. Exposures slower than the above cannot be used because images would be blurred because of the movement of the airplane. The grain must be fine because many of the photographs are enlarged before use and a coarse grain would make it impossible to distinguish the small details.

### 2251 Color Sensitivity

In manufacturing photographic film it is possible, by certain processes, to vary the range of colors to which the film will be sensitive. A normal film emulsion is sensitive to only the blue color region of the spectrum. On this type of film, red and green have little or no effect and, in the positive print, appear very dark. By special treatment, it is possible to make the film sensitive to light throughout the entire region of the visible spectrum, including red. This type of film, known as *panchromatic*, gives a fairly satisfactory reproduction in appropriate black and white tones of all the colors and is the type generally used for aerial photography. Because it is sensitive to all colors, it must be processed in total darkness or with only very short exposures to faint green light or fogging will result.

### 2252 Film Speed

The *speed* of a film is a time measure of its ability to record minimum usable negative density. The film is said to be *fast* or *high-speed* when it will record this density with a very short exposure, and *slow* when it requires a comparatively long exposure. Film for aerial photography must be fairly high-speed because the forward motion of the plane, vibration of the camera, and some other considerations require the use of very short exposures. The speed of a film is fixed by the manufacturing process, but a panchromatic film is generally faster than other types because it is sensitive to light from the entire visible spectrum and hence can make use of all the available light, whereas in nonpanchromatic types the red portion and perhaps some of the green portion of the incident light is not effective because the film is not sensitive to it.

### 2253 Grain

Upon casual examination, a developed photographic negative gives the impression of being homogeneous. This is only an appearance, however, and, upon examination under magnification, a negative will appear to be composed of minute silver particles and will have an appearance similar to a half-tone illustration which, although appearing to be homogeneous when viewed from a normal distance, is actually made of many minute dark

spots which vary in size and give the impression of variance in tone. This characteristic of being made up of many minute particles is called grain and is one of the most troublesome problems in aerial photography. The size of the particles has a marked influence on the ability of the emulsion to resolve fine details—the finer the size of the particle, the greater the ability to resolve and vice versa. Here, as in many other problems in photogrammetry, some of the conditions which are desired are mutually exclusive. In general, the graininess of an emulsion varies in proportion to its speed—high-speed film being composed of very large particles and a slow film having very fine particles. It is impossible to obtain extremely high speed and extremely fine particle size in one film, but in the panchromatic film used in aerial photography, a reasonably satisfactory compromise has been reached wherein the film speed is sufficiently fast to permit the short exposures required and the grain has been kept finer than the minimum resolution conditions that are imposed by lens design, camera vibration, airplane motion, etc., if the photographs are not to be enlarged more than four diameters.

#### 2254 Selection Criteria

In general, the possibilities in the selection of a film to be used for a specific project are not very great because in the design of a film which will meet the criteria set forth for color sensitivity, speed, and grain, the film manufacturers have practically standardized on a single type of panchromatic film whose color sensitivity is such as to render a satisfactory interpretation of colors in terms of black and white tones. This film has sufficient sensitivity in the red part of the visible spectrum to permit the use of haze-penetrating filters of deep yellow, orange, or even red color, of sufficient speed to permit exposures at about 1/200 second even at the aperture of  $f/6.3$  of the wide-angle lenses, and graininess such as to permit the resolution of 50 or more lines per millimeter, which is in excess of the average resolving power of most aerial lenses.

Special conditions may make desirable the use of other than the standard film but the limitations of other types should be considered carefully. For example, it is known that the maximum penetration of haze is achieved by using only the dark red and infrared region of the spectrum. This requires the use of a film that is specially sensitive to the infrared region and this sensitivity is achieved at some sacrifice in speed and at a considerable increase in grain. The resulting photographs show a remarkable resolution of distant details but color tone is quite distorted. Green foliage appears in very light, almost white, tones, and water appears almost black. This latter characteristic can sometimes be used to advantage in order to obtain a very distinct outline of the water's edge on a beach or marsh under conditions where it might otherwise be rather indefinite.

It is probable that, with further development, color film, with which objects can be photographed approximately in their natural colors, will be used increasingly in aerial photography. At present it is very slow in speed and has comparatively poor resolution which, in conjunction with its high cost, difficulty in processing, and lack of a suitable means of making multiple copies at reasonable costs, have combined to restrict its use to military intelligence and certain other very special applications.

#### 226 FILTERS FOR AERIAL PHOTOGRAPHY

Filters are extensively used in vertical aerial photography for mapping purposes. In Coast and Geodetic Survey work, two types serve almost all purposes—the "Minus Blue" (*yellow*) and the 25A (*red*).

A filter consists of a colored disk that is interposed in front of the camera lens for the purpose of restricting the color of the light entering the camera. By this means, colored terrain objects are reproduced in improved shades of black and white, and the resolution of images is increased to some extent when photographing through atmospheric haze. Such filters are generally constructed of colored optical glass or of thin sheets of colored gelatin cemented between two pieces of clear glass. They must be flat, with no curvature that affects focus or distorts the optical image at the film plane, and the two faces must be parallel so that the relationship between the principal point and the recorded terrain details is not disturbed. The usual requirements for mapping photography are that both surfaces shall be flat within one interference fringe and parallel within 10 seconds of arc. For durability and general optical quality, solid colored glass filters are preferable to filters of colored gelatin cemented between glasses.

### 2261 Light and Color

A practical conception of the nature of light is that of a harmonic vibration, with wave lengths varying throughout a certain range within which the sensation of color varies progressively in imperceptible gradations from violet and blue through green, yellow, and orange to red as the wave length increases. These wave lengths are very short and, for convenience, are expressed in special units, either the *millimicron* (0.000001

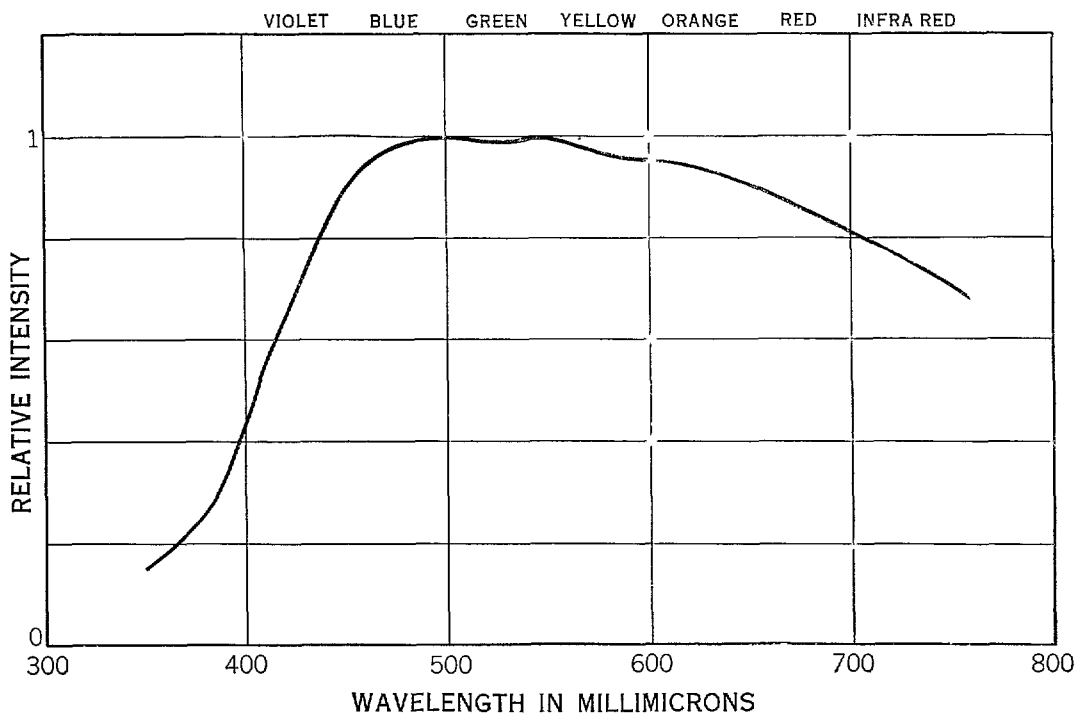

FIGURE 2.9—Spectral distribution of daylight

mm) or the *angstrom unit* (one tenth of a millimicron) The approximate wave lengths of the various colors are

	<i>Millimicrons</i>
Violet -----	400-450
Blue -----	450-500
Green -----	500-550
Yellow -----	550-600
Orange -----	600-650
Red -----	650-700
Infrared -----	Over 700

Average daylight is made up of a blend of all the above colors in approximately the distribution indicated in figure 29

### 2262 *Types of Filters*

A filter transmits light of its own color and absorbs light of other colors The apparent color of a filter may be the result of blending several related colors—for example, the usual yellow filter generally does not transmit blue light (hence is sometimes called a “minus blue” filter) but transmits rather completely the rest of the visible spectrum, including green and red in addition to yellow This type of filter is used to improve tone renditions of colored objects Most photographic film, even some panchromatic types, is more sensitive to blue light than to other colors, hence, blue objects tend to photograph in lighter shades than they appear to the eye and tone renditions are distorted A yellow filter reduces differentially the amount of blue light falling on the film and at the same time transmits a high percentage of the remaining colors This permits the other colors to register their proper densities on the negative without overemphasizing blue

A more important consideration in aerial photography is that atmospheric haze (not to be confused with fog or smoke) tends to diffuse light of the shorter wave lengths but has less effect on colors of longer wave length, progressively decreasing for green, yellow, orange, and red For this reason, filters are used in aerial photography to obtain photographs taken only with the longer wave lengths of light To obtain this result either the yellow or the red filter may be used, depending on the amount of light available

### 2263 *Filter Factors*

Filters always obstruct light transmission through the optical system of a camera and withhold part of the incident light This restricts the use of filters to those whose transmission losses will not require exposures that are longer than practicable in aerial photography where other unrelated conditions require relatively short exposures The amount of light withheld in proportion to the total available is dependent on the spectral transmission of the filter—the greater the spectral range that is transmitted, the smaller is the percentage of light that is unavailable at the film To compensate for this partial loss of light due to the use of a filter, an increase in exposure is required This increase in exposure is usually indicated by a “filter factor” which is a factor by which the exposure required without filter must be multiplied when a particular filter is introduced into the system For the usual panchromatic emulsions used in aerial photography, the factor for a “minus blue” filter is 2.0 and for a 25A filter is 4.0

### 2264 *Filters for Infrared Film*

When the maximum penetration of atmospheric haze is desired, infrared photography gives the best results. Film is available which is particularly sensitive to dark red light and a portion of the spectrum, known as infrared, beyond the visible range of wave lengths. This film is also somewhat sensitive to blue light. A special filter is used in front of the lens, which excludes all the blue light and most of the red light and transmits only the longer wavelengths of red and the adjacent infrared region of the spectrum. By this means, photographs are taken with only the extremely long wave lengths of light which are not as susceptible to diffusion and scattering by the particles which constitute atmospheric haze, resulting in sharper pictures of distant details, unobscured by intervening haze. This characteristic is particularly valuable for high oblique photography or photography with the camera axis horizontal, as in terrestrial photogrammetry where the phototheodolite is used, because a sharper definition of distant features and the horizon results. Photographs taken with this film have characteristic distortions of color tones which require special experience for interpretation. In prints the sky appears practically black, but clouds retain their characteristic brilliant white appearance. Green foliage, particularly of deciduous plants, reflects a large amount of incident infrared light and hence appears almost white, whereas bodies of water appear dark.

The filter used is comparatively dense but, due to the greater sensitivity of the film, the exposures required are comparable to those used in conventional aerial photography.

## 23 AIRPLANE INSTRUMENTS AND ACCESSORIES

### 231 AIRPLANES AND FLIGHT PERSONNEL

In the Coast and Geodetic Survey aerial photography is normally taken by Bureau personnel rather than obtained through contract with commercial companies. A cooperative agreement has been in effect for a number of years between the U. S. Coast Guard and this Bureau whereby a Coast Guard airplane and flight crew are placed at the disposal of the Coast and Geodetic Survey, the latter providing the photographic equipment, navigator, and photographer. This arrangement has been of mutual advantage in that photographic flying experience has been obtained by Coast Guard personnel and the Coast and Geodetic Survey has avoided the expense of procuring and maintaining a single aircraft.

#### 2311 *Airplane in Use*

For a number of years a Coast Guard PB-Y flying boat, succeeded by a PB-Y-5A amphibious flying boat, was used for nine-lens photography and for photography in Alaska. A Grumman JRF-5 amphibious flying boat and later a specially outfitted Beechcraft SNB were used for single-lens photography.

In 1949 a PB-1G(B-17) airplane is being used for both nine-lens and single-lens photography. The PB-1G is a version of the Boeing B-17 or "Flying Fortress", it has four engines and landing wheels and won renown during World War II as a bombing airplane. The PB-1G cruises at 180 miles per hour, has a maximum altitude for photography of 30,000 feet, and a cruising range of 7 to 9 hours.

Of the aircraft mentioned above, the PB-1G is by far the most satisfactory from the standpoint of photographic operations. This airplane, in present use for all photographic flying, is a large bombing plane, stripped of armor and armament, which has large

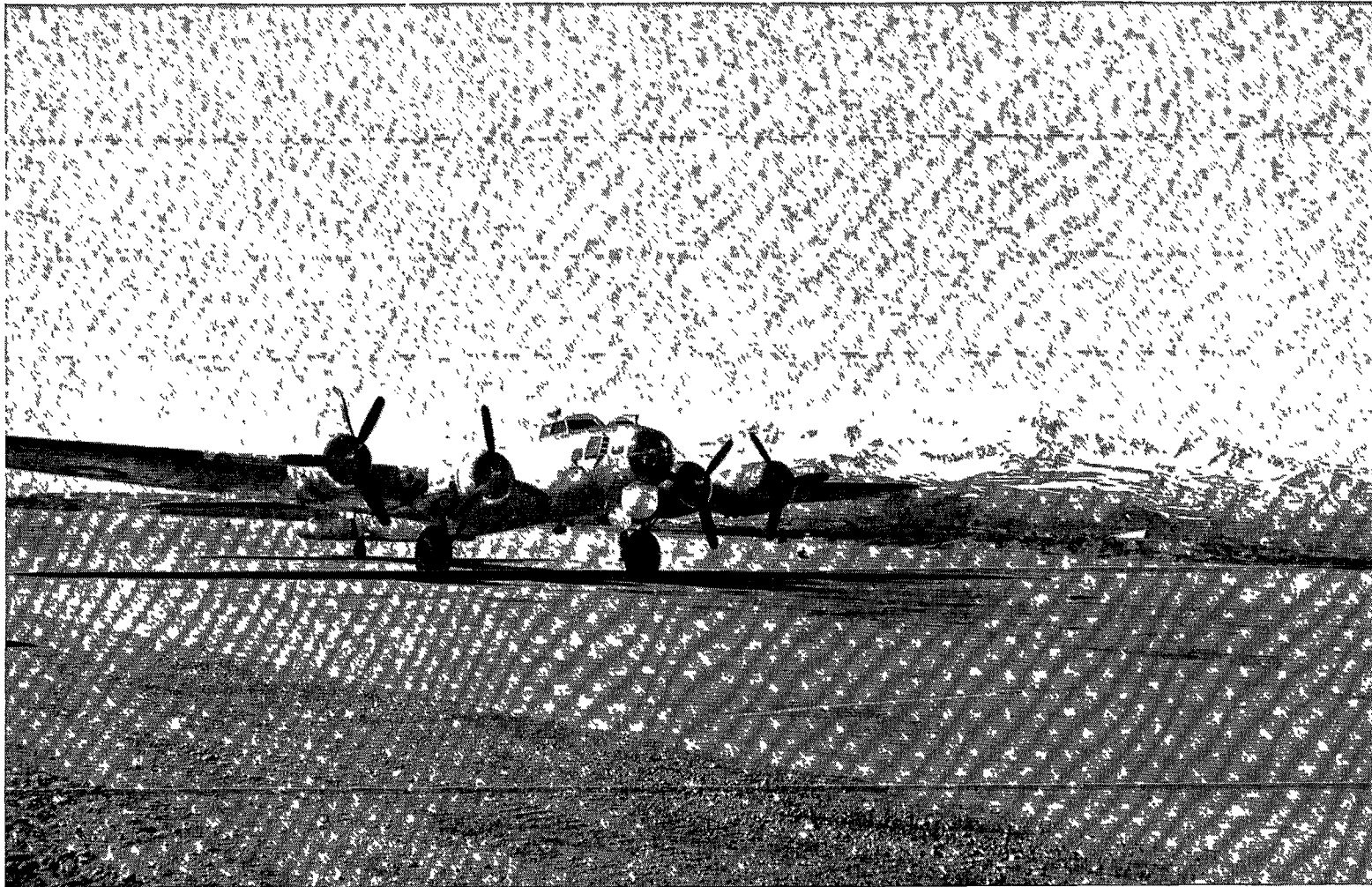

FIGURE 2 10 —U S Coast Guard PB-1G airplane No 77254



capacity, high speed, rate of climb, and ceiling, good stability, unusually long cruising radius, complete instrumental equipment, including a Loran navigating installation and radar, and excellent visibility for the navigator, all of which make it a superb aircraft for aerial photography. It is particularly well suited for operations in Alaska where long distances must be traveled between bases or between base and working ground and where mountainous terrain requires high-altitude flying. In such territory, the additional safety provided by four engines is a comforting feature.

### 2312 *Flight Personnel*

Personnel furnished by the Coast Guard varies somewhat with the type of airplane but always includes a pilot, radio operator, and essential maintenance personnel. The operation of the aircraft is, of course, under the regulations of the Coast Guard and all matters of flight policy are decided by the pilot, who is the Commanding Officer. However, unless prohibited by regulations, photographic flights are undertaken at times and in localities designated by the Coast and Geodetic Survey. The photographic navigator is generally a commissioned officer of the Coast and Geodetic Survey who has been specially trained for the purpose, and who is a qualified pilot who has been through naval flight school and generally is a designated naval aviator. Because of this training he is acquainted with the problems incidental to aircraft operations and is able to cooperate intelligently with the flight personnel to the end that photographic operations are coordinated and accomplished efficiently. It is the function of the navigator to plan the day-to-day operations of the mission, to consult with the pilot on the most expeditious means of accomplishing the desired photography and, during actual operations, he is responsible for the actual navigation of the aircraft during aerial photography and for the direction of the photographer's activities, telling him when to start and stop photography, checking drift and interval between exposures, etc., to see that the photographs comply with the specifications. Insofar as the Coast and Geodetic Survey is concerned, he is the Chief of Party and is responsible for carrying out assigned photographic projects. The aerial photographer is a Civil Service employee of the Coast and Geodetic Survey who has been especially trained in the maintenance and operation of aerial cameras—particularly the nine-lens camera—and associated equipment, and in the handling and processing of aerial film. He is responsible for the numerous camera operational details required to produce aerial negatives of satisfactory quality. This includes the proper settings for exposure, interval, drift, and leveling of the camera at the moment of exposure, development of test exposures, and making recommendations to the aerial photographic laboratory as to details of processing to obtain the optimum results.

### 232 FLIGHT OPERATION

The PB-1G airplane (see 2311) has been modified and specially equipped for aerial photography. A single-lens camera and the nine-lens camera are installed and can be operated simultaneously. A special photographic hatch already in the radio compartment is used for the single-lens camera. Special windows have been provided in the fuselage to permit taking oblique photographs. For the nine-lens camera, the ball turret has been removed and a special mounting placed in the hatch. A hand-operated winch is installed over the opening to hoist the camera aboard and handle it while it is being placed in the mount. Vacuum for the single-lens camera is provided from the vacuum line installed for the navigating instruments of the airplane. A special electrically-driven pump provides vacuum for the nine-lens camera.

The navigator is stationed in the bombardier's compartment which is in the plastic nose of the plane. Unusually good visibility is provided in almost all directions. Equipment at this station includes outside air thermometer, sensitive altimeter, flux gate compass repeater, air speed indicator, bombsight, auto pilot, and two astro-compasses specially mounted to serve as sighting devices for checking coverage and overlap between adjacent flight lines. A microphone and a headphone permit communication with any member of the crew.

The photographer's station is at the cameras where he is provided with viewfinder, drift sight, intervalometer, and communication facilities.

The pilot, of course, has all the flight controls and the necessary instruments for operation and navigation.

Prior to a photographic flight, the pilot and navigator discuss the general plan of operation and the photographer is instructed as to which camera is to be used, the number of flight lines, etc. When the airplane has been serviced and is ready, the pilot takes charge, takes the plane off the ground, and flies it to proper altitude and to the general vicinity of the photography. Altimeter corrections are computed by the navigator and furnished to the pilot for use in attaining correct altitude.

Upon reaching the project area, the pilot connects the plane to the automatic pilot, and transfers control to the navigator who can navigate the plane from his station by means of control buttons on the automatic pilot, which is connected to the bombsight.

The navigator locates his position and actually flies the plane to the correct position for the start of a photographic line. The plane must be placed in approximate heading and position several miles before the start of the line to permit adjustment for drift, heading, and position. The heading is furnished by the flux gate compass if the line is defined by direction on the flight diagram. Drift is determined by observation through the bombsight, applied to the compass heading for true direction, and furnished to the photographer who must set the proper drift angle on the camera mount to eliminate "crabbed" pictures. Using the bombsight, the navigator determines the position of the flight line with respect to landmarks shown on the flight diagram or determined by the sighting devices for overlap from a previous parallel flight. The position and direction of the flight line are refined and corrected by the navigator who has control of the plane and the instruments to indicate heading and position.

When the plane is on correct course, the navigator tells the photographer to stand by to start photography. The photographer has in the meantime checked the equipment for operation, set off drift, and checked the time interval. When the plane is in position, the navigator directs the photographer to start photography. The photographer usually has the camera set for automatic operation at a predetermined interval by the intervalometer. So that the camera may be manually leveled at the moment of exposure, a warning light that is connected into the intervalometer circuit lights up for 5 seconds before each exposure. A light also flashes at the navigator's station to indicate each exposure and to warn him not to make any course or altitude correction during the interval that the light is on. The nine-lens camera has a special intervalometer connected to a telescopic viewfinder and drift sight. The reticle consists of a traveling grid which is moved across the field by a variable-speed motor. The rate of travel is synchronized with the motion of the ground image. The device actuates the camera automatically at the correct time interval to give the desired end lap. End lap is selected and set in the intervalometer at any desired percentage. The camera continues to operate, automatically winding film and tripping the shutter until the photographer stops the mechanism when

advised by the navigator that the end of the flight line has been reached. The photographer must be constantly alert to level the camera at exposure and to note that the vacuum is being properly applied, that the film-winding mechanism and intervalometer are functioning properly, and from time to time he must check the drift angle and ground track in the sight so that adjustments may be made for crab and interval if the wind changes.

When the day's operation is completed, the flight diagrams are checked, the rolls of exposed film are numbered and, if deemed necessary, test exposures are developed in the field to check exposure, operation of the camera, etc.

### 233 INSTRUMENTS FOR AERIAL PHOTOGRAPHY

Although high-quality aerial photography is dependent in a large degree on the personal alertness and skill of pilot, navigator, and photographer, the successful accomplishment of aerial photography is materially assisted by the use of numerous instruments, some of which are part of the normal navigating equipment of the airplane and others which are specially provided for the purpose.

#### 2331 *Compass*

Flight lines are frequently flown in accordance with designated landmarks indicated on a previously prepared flight map. But in many instances, notably in the case of area coverage where numerous parallel lines are to be flown, or in areas where landmarks are nonexistent or have not been charted, the use of a compass will permit the flight lines to be flown in the proper direction. Three corrections must be applied to a compass reading before it can be assumed to indicate a correct direction: (a) correction for *declination* of the magnetic meridian, (b) correction for *calibration* of the individual instrument due to inaccuracies in construction and graduation or to local attractions caused by the proximity of magnetic materials or electric currents, and (c) correction for *drift* necessitated by the fact that the fiducial axis of the compass is aligned with the longitudinal axis of the airplane and is not parallel to the actual line of flight of the airplane. Compasses in general use today are of two types: (a) the *magnetic needle* type and (b) the Flux Gate type. The magnetic needle type of compass, which has been used on some of the smaller photographic airplanes, is similar in principle and application to the surveyor's compass and the various types of marine compass. It consists essentially of a magnetic element that is freely suspended at its center of gravity in such manner that it will rotate and assume a position parallel to the lines of force of the earth's magnetic field. A graduated scale of some type is affixed to the magnetic element so that the heading of the aircraft with respect to the magnetic needle is indicated in degrees. The motion of this type of instrument is physical and is induced by the force of the earth's magnetic field acting on the magnet, the slight torque resulting therefrom swinging the needle about its finely balanced pivot until it reaches the point where it is parallel to the field and no torque is acting on it. In this type of instrument, the sensitive element and the entire mechanism are located on the instrument panel. This location necessitates large and varying calibration corrections because it is close to the electric system of the airplane and many extraneous metal objects which attract it. Because of its delicate suspension, the needle has a tendency to swing with the various motions of the plane and to oscillate and hence it must be read at its average position during these variations. It is also subject to "turning error" when the airplane is banked during turns because the vertical component of the earth's magnetic field tends to rotate the dial and give false readings.

The Flux Gate compass with which the PB-1G airplane is equipped operates on a fundamentally different principle, although it indicates the aircraft's heading with respect to the earth's magnetic field. The Flux Gate system comprises several elements, namely, the Flux Gate transmitter, the amplifier, the master indicator, and several remote indicating repeaters. The Flux Gate transmitter consists of an azimuth-sensitive element which is gyroscopically stabilized in a horizontal position, so that, despite tips, tilts, and inclinations of the aircraft during flight, it is sensitive only to the horizontal component of the earth's magnetic field. This element does not rotate but is sensitive to azimuth because of variations in its orientation with respect to the earth's magnetic field. The result is that the compass, under all normal conditions of flight, does not oscillate due to plane motion and does not give erroneous indications due to turning or other acceleration. The azimuth-sensitive element itself consists of three equal arms forming a triangle, each arm having a core of high-permeability alloy, and each provided with an exciting winding and a pick-up winding. In use, the exciting winding is energized from an outside alternating current source and when so energized a voltage is induced in the pick-up winding, which voltage is a function not only of the original current but also of the earth's magnetic field. The voltage in the azimuth-sensitive unit is influenced by the earth's magnetic field and is a function of the unit's orientation with respect thereto and, because each of the three arms is oriented differently, differential voltages result which interpret the orientation of the unit to the master indicator. These three voltages are fed into the master indicator which has electric devices which analyze them and cause a motor to drive the master indicator pointer around a graduated azimuth scale to a position where the electric input is balanced and the orientation of the transmitter unit with respect to the earth's magnetic field is indicated. This indication is the magnetic heading of the airplane. This reading is available at the master indicator and can also be repeated at several electrically controlled remote indicators variously placed where needed in the aircraft.

The Flux Gate unit is generally located on a wing or in some other rather remote part of the airplane where it is as isolated as possible from other magnetic or electric influences which might tend to give false indications. The instrument has internal arrangements for compensation for magnetic declination and local deviation.

### 2332 *Altimeter*

To take photographs at the scale required, the altitude of the airplane above the ground must be controlled within rather close limits. The *altimeter* normally indicates the altitude above mean sea level and must be corrected for the average elevation of the terrain being photographed. The elevation of the terrain is usually determined from existing maps or by estimation. The altimeter is a type of aneroid barometer which is actuated by the static air pressure but which is calibrated to indicate altitudes in feet above mean sea level. The calibration is based on the relation between air pressure and altitude in an ideal atmosphere—in the United States usually from the table of the U. S. Standard Atmosphere,<sup>1</sup> which presumes a sea level pressure of 760 mm (29.921 inches) of mercury and a temperature at sea level of 15° C (59° F). The air pressure in this table decreases with increase in altitude in accordance with a logarithmic variation mathematically derived, but based on certain physical elements, such as the density of air at standard pressure and temperature, which have been determined experimentally. In

<sup>1</sup> National Advisory Committee for Aeronautics, Report No. 218, 1942.

this mathematical derivation, the temperature is assumed to decrease approximately 3.6° F for every 1000-foot increase in elevation. A few values for selected altitudes from the table of U. S. Standard Atmosphere are given in table 2.3.

TABLE 2.3—Pressure—altitude equivalents

Altitude	Barometric pressure	Air temperature
<i>feet</i>	<i>inches of Hg</i>	<i>degrees F</i>
0	29.92	59.0
500	29.38	57.2
1,000	28.86	55.4
2,000	27.82	51.9
3,000	26.81	48.3
4,000	25.84	44.7
5,000	24.89	41.2
10,000	20.58	23.3
15,000	16.88	5.5
20,000	13.75	-12.3
25,000	11.10	-30.2
30,000	8.88	-48.0

As the standard conditions assumed in the table seldom obtain exactly in actual practice, readings must be corrected for the two factors that cause the largest corrections—variation from standard sea level pressure, and variation from standard air temperature. It is a well-known fact that the atmospheric pressure at sea level can, and does, vary considerably from day to day with variations in weather conditions. This variation causes an altimeter at sea level to indicate elevations that vary with the barometric pressure. The magnitude of this variation is of the order of  $\pm 500$  feet. Provision is made on sensitive aircraft altimeters to correct for this variation. There are two ways of determining the required correction. The simplest method is to set the altimeter to indicate true elevation while the airplane is still on the ground, if the elevation of the airport is known—the barometric pressure need not be known at all. This method is undesirable owing to the fact that the barometric pressure is seldom uniform over any large area and that any setting so obtained becomes increasingly unreliable as the distance from the base where the setting was made increases. But corrections can be made in flight. At numerous airports and weather stations in continental United States and some parts of Alaska the barometric pressure is continually observed and aircraft in flight can obtain the necessary data by radio to correct their altimeters for the pressure at the point of observation. The altimeter has an auxiliary dial graduated in atmospheric pressure units that can be rotated by means of an external knob. To make the correction the auxiliary dial is rotated until it indicates the observed sea level barometric pressure as reported from the ground. It must be emphasized again that corrections of this type become increasingly unreliable as the distance from the point of observation increases.

Altimeter readings must also be corrected for variation of the atmospheric temperature from the standard assumed in the table. The density of air decreases with increase in temperature and vice versa. To correct theoretically for air temperature, the temperature of the entire column of air between ground and aircraft should be known. In aerial photography readings of outside air temperature are made at 2000-foot intervals during ascent to photographic altitude. The average of these readings gives an approximate

average air temperature Various tables and special computers are available for the determination of this correction, and the instructions which accompany them should be followed These corrections are usually arranged so that, when applied to an observed altitude, the corrected or "true" altitude will be obtained In aerial photography certain specified altitudes must be flown as accurately as possible and the table must be used in reverse to obtain a correction to the theoretical reading of the altimeter, which corrected indication, when attained, will actually be that required for the desired photograph scale

Other corrections, such as for humidity, gravity acceleration, etc., are theoretically required but in ordinary practice are omitted because of their small magnitudes, which are generally less than observational errors in the system

### *2333 Air Thermometer*

To correct aneroid altimeter readings for average outside temperature (**2332**) a special thermometer with a sensitive element is used which is mounted where it is directly exposed to the outside air but with a direct reading dial on the instrument panel at the navigator's station

### *2334 Drift Sight*

Photographic flight strips must be parallel and the edges of the individual photographs in each flight should form continuous straight lines without offsets at the corners where the photographs overlap To attain this, the fore-and-aft axis of the aerial camera must be kept parallel with the flight line Because a moving aircraft must head into a cross wind in order to proceed in a given direction, the axis of the airplane is seldom parallel to the line of flight—it is generally at an angle whose amount depends on the direction and force of the cross wind In order to place the camera parallel to the line of flight, the angle between the aircraft heading and the true course made good must be determined, and the camera must be rotated in its mount by this same angle In the PB-1G, drift is determined with the bombsight (**2336**) Drift can be checked by the photographer with the drift-sight device combined with the viewfinder of the camera Rotation of the viewfinder so that the apparent ground motion is parallel to a series of lines engraved on the viewing screen, automatically rotates the camera the correct amount The type B-3 drift sight, formerly used with the solar navigator (**2337**), is provided with gyroscopic stabilization and a rotating objective prism arranged so that the exact ground track of the airplane can be very accurately determined and so that it can be projected forward and the point towards which the airplane is proceeding determined some distance ahead In this device an attempt is made to isolate the instrument from the normal oscillations and variations in attitude that are inherent in any aircraft during flight This is achieved by providing a reticle which is not rigidly attached to the instrument, but which is suspended pendulously, with a gyroscope incorporated The pendulous suspension tends to maintain the reticle in a horizontal plane and the gyroscope restricts it from responding to the random impulses given to it by the accelerations of the aircraft Precession of the gyroscope, which is a long-period motion, is corrected by the pendulous mount which will not permit the gyroscope to respond The terrain below does not have a jerky random motion with respect to the reticle in this instrument—instead, regardless of the accelerations of the plane, the reticle appears to be in direct contact with the ground, thus permitting the ground to be tracked and the drift angle to be determined rather accurately When the drift angle is determined with this instrument by observation of the ground beneath the plane, a prism in front of the objective

lens can be tilted to project the ground track line forward so that the destination can be observed accurately. This is very helpful in aerial photography where flight lines have to be accurately flown with reference to landmarks. This navigational aid indicates sufficiently in advance the airplane's track with reference to landmarks ahead so that changes in course can be made in time to correct the direction and placement of flight lines.

### 2335 *Automatic Pilot*

The automatic pilot is a device that is connected to the controls of the airplane to maintain straight line flight at a constant altitude with automatic correction for pitch and roll. This result is accomplished through a gyroscopic control mechanism which transmits electric signals which are interpreted, resulting in appropriate corrective motions to the control surfaces of the airplane. The corrections to deviations from straight and level flight are practically instantaneous under average air conditions. The use of the automatic pilot results in straighter flight lines with photographs with less tilt than is possible through manual piloting.

The automatic pilot itself does not steer the airplane onto a preselected heading or ground track, but it does maintain, within the limits of a gyroscopic device, the heading to which the plane has been otherwise directed.

The automatic pilot is connected with the bombsight so that the navigator can control the airplane, controlling azimuth manually, while the automatic pilot maintains altitude and corrects for pitch and roll.

### 2336 *Bombsight*

The Norden bombsight on the PB-1G is a complicated gyroscopic device designed to permit the evaluation of and proper compensation for all the various ballistic factors involved in the solution of the problem of dropping a bomb from a moving airplane and hitting a target on the ground. Some of these factors are involved in placing an airplane on a photographic flight line and the instrument is used to good advantage in this simplification of the general case.

The drift angle can be set in the bombsight and, by means of a movable telescope, the exact direction in which the airplane is traveling can be projected ahead and the line of flight can be aligned with targets or landmarks that have been previously selected as control points for a photographic flight line. It is also possible, by means of a variable-speed motor, to point the telescope at a distant point on the flight line and keep it continuously pointing at it in spite of the forward motion of the plane. Thus it is possible to determine the exact ground track of the airplane and the time of arrival over the point.

Photographic flight lines are followed in one of two ways, either by passing over a specific landmark while making good a specific true course, or by keeping on range two or more landmarks whose ground positions determine the direction of the flight line. In the first case, the airplane is placed on course by compass or by some other azimuth-indicating device with due allowance for drift. The bombsight is then used to determine the relation of the ground track to the preselected landmark, and the position of the airplane in flight is changed until, when on the given course, the projected flight line as indicated by the bombsight passes through the landmark. In the second case, the airplane is placed on an approximate heading and, by means of the projected line of flight furnished by the bombsight, the direction and position of the line of flight are adjusted until it is apparent that the plane will fly over both landmarks as required.

A major advantage of the bombsight is that it is interconnected with the automatic pilot (see 2335) in such way that the airplane can be controlled in direction by the bombsight and the course can be adjusted directly by the photographic navigator to the end that the flight line is positioned exactly, without any action whatsoever by the pilot. In other words, during the initial approach and while on the photographic flight line the airplane is actually under the control of the navigator—not the pilot.

### 2337 *Solar Pilot Director*

The *solar pilot director*, or *solar navigator* as it is sometimes called, is a device for maintaining an airplane on any desired course by reference to the sun. Such a course is referenced to the true meridian, without reference to the earth's magnetic field, and is compensated for drift. This instrument is not used in the PB-1G but has been used in other planes for single-lens photography.

The solar navigator consists essentially of a small equatorially-mounted telescope and mirror which are driven by a clock at a rate equal to the average motion of the sun, and in whose focal plane are two parallel photoelectric plates separated by a central strip of non-sensitive material. Leads from the photoelectric plates connect to the two sides of a galvanometer-type indicator which is installed on the instrument panel of the airplane where it is readily visible to the pilot. The telescope and associated parts are mounted in the top of the airplane in the center of an opening cut through the hull of the plane, which opening is protected by a hemispherical plastic dome where the sun's rays from any direction are unobstructed. The device is located at the center of a horizontal graduated circle which indicates the actual course of the airplane and with reference to which the desired course may be set. The axis containing the telescope is tilted to correspond to the latitude and, under certain conditions, the telescope may be inclined for declination. Rotation about the equatorial axis is by a clock set for Greenwich time. The longitude correction to time is set into the clock by rotating the entire mechanism by the hour angle corresponding to the longitudinal difference from Greenwich.

In flight, the airplane is steered by compass to within  $10^\circ$  of the desired course where the solar navigator begins to function. The sun's rays enter the telescope obliquely and are concentrated on one of the photosensitive plates, and the photoelectric action produces a current which causes a deflection of the indicator on the instrument panel. This indicator is so set that it shows the direction toward which the plane must be turned to approach the true course. As long as the plane is on true course, the sun's rays are concentrated directly in the center of the telescope field and do not strike either photosensitive plate. Since no current is produced in that event, the indicator is not deflected and the needle remains straight up, indicating that the plane is "on course." The control obtained through this instrument is visual and corrections for "off course" indications must be applied manually by the pilot. The instrument, therefore, is not similar in any way to an automatic pilot, but merely furnishes visually a continuous solar azimuth observation which is transmitted electrically to the pilot by means of the indicator dial.

The instrument is always used in conjunction with a gyroscopically stabilized B-3 (Pioneer) drift sight (see 2334) by which the course made good can be projected ahead. The rotating part of the drift sight is connected to the azimuth-sensitive part of the solar navigator by autosyn motors, so that the established angle of drift is automatically set in the solar navigator head at a point above the azimuth circle, so that true azimuths are indicated and flown automatically when the drift is correctly set. This instrument is most



useful in flying lines over areas that are devoid of landmarks and identifying features or where there are no maps that can be used to locate the flight lines with reference to landmarks. With this instrument it is possible to fly flight lines very nearly in the desired direction, and with its associated drift sight to position the flight lines and determine ground speed readily.

### 2338 *Intervalometer*

If aerial photographs are to be effective for mapping they must be flown in strips in such manner that the centers of the immediately preceding and following photographs will fall just within the limits of the photograph being taken. In other words, as generally stated, the forward overlap must be a little more than 50 percent. (See section 2421 for end-lap specifications.)

During aerial photography photographs are properly spaced by timing the interval between exposures. It is readily apparent that the time required between exposures is a function of the angular field of the camera, the flying height of the airplane, and the ground speed of the airplane. Once the camera has been selected and the scale determined, two of these variables have been fixed, and the photographic navigator has only to determine the ground speed of the airplane. Ground speed cannot be determined directly from air speed because it is also a function of the direction and force of the wind at photographic altitude. The ground speed itself is generally not actually measured—instead, the time that elapses while the airplane is traveling an angular distance equal to the angle between adjacent photograph centers is measured. This is done with the bombsight, the B-3 drift sight, or with the camera viewfinder, with any one of which it is possible to observe a ground object as it passes across the field of view and to determine the time that it takes to pass a given number of degrees.

Most aerial cameras are equipped to be operated electrically and an electric impulse trips the shutter, winds the shutter for the next exposure, and advances the roll of film so that it is in position for the next exposure. It is possible to operate such cameras manually, using a stop watch to space the exposures. However, an *intervalometer* is usually used to furnish these electric impulses to the camera automatically, at any desired interval that is set on its dial. The photographer is then free to check drift, overlap, position of flight lines, and general operation of the camera without having to concentrate on timing the exposures.

### 2339 *Miscellaneous Equipment*

In addition to the navigating instruments and photographic equipment, the airplane should be provided with an interphone system so that pilot, navigator, and photographer can converse freely and thereby obtain a maximum of coordination with a minimum loss of time.

For personal comfort and efficiency, it is quite necessary that the airplane be provided with an efficient heating system since photographs are generally taken at comparatively high altitudes where temperatures would otherwise be very uncomfortable to operating personnel with attendant loss of efficiency.

Oxygen should be available in all photographic airplanes because operations are generally at 10,000 feet or higher and oxygen is generally considered desirable for personnel at these altitudes.

## 24 GENERAL INSTRUCTIONS FOR AERIAL PHOTOGRAPHY

Project instructions accompanied by flight maps are prepared by the Washington Office for aerial photography. The project instructions include specifications for all those phases of aerial photography that vary from project to project, such as the camera to be used, the altitude, etc. This section includes the general instructions which shall apply to all projects unless otherwise stated in the project instructions.

### 241 FLYING FOR AERIAL PHOTOGRAPHY

#### *2411 Placement of Flight Lines*

Flight lines shall be placed as indicated on the flight maps except where local conditions make it impracticable to fly the lines exactly as shown on the maps. The exception applies particularly to photography in Alaska where the available maps are sometimes not suitable for flight maps. In such regions, the flight maps may be considered as indications of the coverage desired and, if the specified lines cannot be followed exactly, coverage may be obtained in the most feasible manner, adhering to the requirements for end lap and side lap.

Where clear weather is the exception, and it is necessary to photograph through openings in the clouds, the direction of the lines may be changed to take advantage of the clear areas, planning to return later to photograph the omitted areas. This should not be done, however, unless it is reasonably certain that the gaps can be photographed later to cover the area completely.

On every flight line the airplane shall be at altitude and on course at least 2 minutes before taking the first photograph. This provides a minimum time for steadying on course and attaining the level flight necessary for satisfactory photography.

#### *2412 Scale and Altitude*

The flight altitude above sea level will be specified in the project instructions. This altitude shall be attained by reference to a suitable sensitive altimeter, corrected for local station pressure when practicable, and for the average temperature of the air column. Radio reports shall be used for this purpose when available during long flights. The temperature of the air should be noted at every 2,000 feet of altitude while climbing. If a continuous gradual decrease in temperature is noted, the average of sea-level and flight-altitude temperatures may be used, but if not, the average of all temperatures must be used to obtain a satisfactory correction. (See **2332**.)

The altimeter index correction shall be checked on the ground at frequent intervals by setting the station pressure dial to the correct value and comparing the altitude reading with the elevation of the airport.

#### *2413 Tilt*

Every effort shall be made by navigator, pilot, and photographer to avoid tilted photographs. Flight lines shall be started sufficiently in advance of the first photograph to align the airplane on course and position and to avoid any but minor corrections to position or altitude during actual photography. The photographer shall make every effort to level the camera as exactly as possible at the moment of exposure.

2414 *Turns*

So far as practicable, flights shall be made on straight courses, except where otherwise indicated on the flight maps. Where the course of a flight line changes a greater number of degrees than permissible, a 180° turn shall be made and the airplane shall be flown back far enough to turn and allow a period of at least 2 minutes for steadying on the new course before reaching the position for the next photograph. This is essential for the proper regulation of overlap and crab and to avoid possibility of excessive tilt. The automatic pilot (2335) shall be used to fly photographic flight lines. The permissible minor corrections to course during photography should be started about 2 seconds after the camera warning light has gone out so that there will be as much time as practicable for steadying down before the next exposure, no correction to course or altitude shall be made while the light warning that a photograph is to be taken is lighted.

(a) *Nine-lens*.—The course of a flight line shall not be changed more than 15° for 1 10,000 scale photography or more than 30° for 1 20,000 scale photography.

(b) *Single-lens*.—The course of a flight line shall not be changed more than 5°.

## 242 PHOTOGRAPH COVERAGE

The desired coverage is indicated on the flight maps. If the map base is inaccurate, deviation from the outlined pattern of flight lines and *pin*-points is authorized, but the indicated area shall be adequately covered, applying the following principles:

(a) The coast shall be photographed in straight flights, as nearly over the shoreline as practicable, while complying with the requirements regarding turns (2414) and ensuring that the centers of very few photographs are above water areas. To avoid numerous turns or breaks in the flight line, it is satisfactory if the shoreline appears not farther seaward from the centers of the photographs than the center of a wing print on nine-lens photographs or than about three fourths of the distance to the edge of single-lens photographs, in areas where the coast is low and flat or gently sloping. Where the coast is rugged, and bordered by steep slopes or bluffs, it is essential that photographs be centered over, or very nearly over, the shoreline, or, where the shoreline is one side of a waterway, that it appears not more than halfway out in the wing print of nine-lens photographs or three fourths the distance out on single-lens photographs of a flight along the other side of the waterway. Where the coast is broken and indented, the navigator must have the photographer *pin-point* each exposure along the approximately straight flight lines, instead of using a regular interval, so that the photographs can be centered over the land, so far as practicable, with all parts of the coast appearing in at least two photographs. The navigator shall use the bombsight or other suitable device to enable him to expose *pin points* with suitable overlap along flight lines. As an island or peninsula is approached, it should be practicable to estimate whether two, three, or four exposures will be necessary to obtain views of both slopes of hills, but the overlap should seldom exceed 80 percent unless the slopes are very steep and high and should never be less than 55 percent.

(b) It is important that every detail of the shoreline appears clearly in at least two photographs. A careful watch must be kept, and places that do not appear should be marked on the navigator's chart immediately as they are noticed and *pin-pointed* at a later time. Shoreline may not appear satisfactorily on two photographs because of being hidden by steep bluffs, because of being on peninsulas or points projecting seaward too far from the photograph centers (see a), or from other causes. When taking *pin points* the requirement for turns (see 2414) must be complied with.

(c) The terrain shall also be watched to make sure that the bottoms of the valleys and all slopes appear on at least two photographs. *When using the nine-lens camera* and the flight strip approaches a volcanic cone, an isolated peak, or sharp ridge much higher than the adjacent terrain, or a deep narrow valley transverse to the flight, *the automatic regular interval shall be abandoned* and photographs shall be taken at the shortest interval that the winding cycle and re-establishment of the vacuum will permit, until the terrain beneath the camera is again at the general level.

(d) If a flight line crosses the shoreline it is essential that the first and last photographs over land, be so positioned that their centers are over or very close to the shore (see also 2441(e)).

### 2421 *End Lap*

The end lap (overlap in line of flight) shall be as follows

(a) *Nine-lens*—Successive exposures along the line of flight shall overlap approximately 67 percent. If relief exceeds approximately 5 percent of the flying height, or if the terrain is rough with steep slopes or bluffs, the end lap shall be increased to approximately 80 percent computed at the average terrain elevation. The regular interval shall be abandoned while crossing a mountain or deep transverse valley. Photographs of such terrain shall be taken as often as the camera cycle of operation will permit.

(b) *Single-lens*—End lap on single-lens photographs shall be 60 percent with a tolerance of  $\pm 5$  percent. Where terrain relief exceeds approximately 5 percent of the flying height so that for the highest terrain there is an effective decrease in the flying height above the ground, the nominal timing interval shall be decreased to give overlap not less than 55 percent for the highest terrain.

### 2422 *Side Lap*

The side lap (overlap of adjoining flight lines) shall be in accordance with the following provisions, to be measured on the net width of the strips, deducting offsets caused by crab (see 2423)

(a) *Nine-lens*—Side lap shall average 60 percent with a tolerance of  $\pm 10$  percent. Spacing of lines must be reduced in areas of pronounced relief so that the side lap is not less than 60 percent for the average terrain nor less than 10 percent for the highest points such as isolated peaks. If mountain ranges are parallel to the flight lines, additional strips may be required to provide usable stereoscopic coverage.

(b) *Single-lens*—Side lap between adjacent flights shall be 30 percent with a tolerance of 15 percent. This nominal side lap shall be increased for terrain with pronounced relief so that the minimum side lap for the highest terrain on any particular flight strip shall be 10 percent. Requirements for side lap are to be applied when area coverage is specified or in the determination of necessity for reflight where actual flights do not correspond to the requirements of the flight map. The flight lines indicated on the map should be followed where side lap in excess of these requirements is indicated.

### 2423 *Crab*

If the photographs in any flight are crabbed in excess of  $10^\circ$  from the direction of the flight line as indicated by the principal points of consecutive photographs, the line shall be reflown.

## 243 PHOTOGRAPHY

Photographs for use in mapping must be of the highest quality obtainable with the equipment used and under the conditions prescribed in the specifications and instructions. This requires constant attention and effort by navigator and photographer to ensure perfect functioning of equipment at all times, and a continuing endeavor to devise improvements in procedures, methods, materials, and equipment so that all photography secured by the Bureau will be of optimum quality and utility.

### 2431 *Photographic Quality*

Except as approved for special conditions, as when photographing airports or harbors for revision, photographs shall not be taken for mapping with the nine-lens camera when the visibility of the terrain from photographic altitude is less than 15 miles in a direction toward the sun, or with a single-lens camera when less than 10 miles. There shall be less than 10 percent of clouds or cloud shadows in the area photographed, except that this limit may be waived in order to complete an area, providing additional photographs are taken of the obscured places to show all the terrain clearly on at least two photographs. In the United States photographs shall not be taken when the sun is less than  $30^\circ$  above the horizon. These requirements cannot be strictly followed in Alaska, where photographs should be taken whenever the light is sufficient to obtain negatives of satisfactory density.

2432 Solar Altitude Diagram

Various tables and charts are available for determining the time and duration of solar altitude above the minimum of 30° prescribed in 2431. Figure 2 11 is convenient for

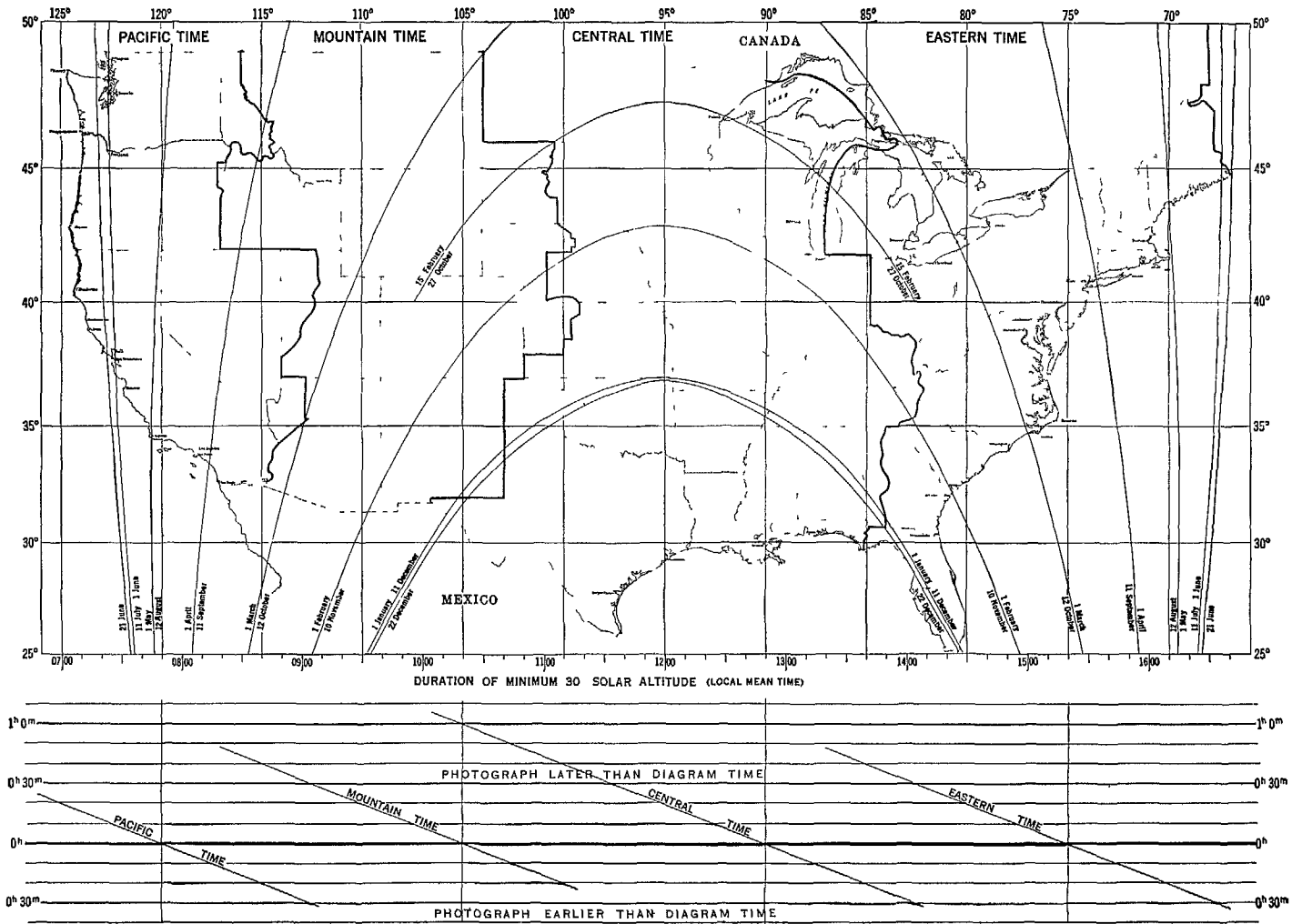

FIGURE 2 11 —Duration of Minimum Solar Altitude

determining the time and duration of solar altitude in the United States. It consists of a map of the United States on which has been superimposed a series of curves indicating the duration of solar altitude in excess of  $30^\circ$  at various dates and latitudes. The latitude scale of the curves is the latitude scale of the map. The time scale of the curves is horizontal but is not related to longitude. To use the diagram, plot on the map the position of the area to be photographed and draw a horizontal line through this position. Estimate by interpolation the position of a curve for the date of the proposed photography. Drop verticals from the intersections of this estimated curve with the horizontal line already drawn through the location of photography. The intersections of these verticals with the time scale at the bottom of the diagram indicate the times between which the sun is above an altitude of  $30^\circ$ .

The times given are local mean time. They must be corrected for difference in longitude between the site of photography and the meridian of the standard time zone. The correction is found by dropping a vertical from the map position of the photography to the correction diagram at the bottom of the map. This vertical line will intersect the diagonal line for the appropriate standard time zone. A horizontal line is drawn through this intersection to the edges of the map. The intersections of this horizontal line with the vertical time scales at the edges of the map indicate the proper correction to make to change local time to standard time, and the proper sign of the correction is indicated by the notes, *Photograph earlier than diagram time*, or *Photograph later than diagram time*. The diagram is constructed for use with standard time. If daylight-saving time is used, the appropriate correction for it must also be made.

#### 2433 Test Exposures

At least one negative of each day's photography should be developed as soon as practicable after the flight to check for exposure and functioning of the camera. If necessary, additional exposures shall be developed, varying the time and/or the developer until a satisfactory development has been obtained. Complete data regarding the development and the flight shall be entered in the photographic flight log. Standard time shall be used and the time meridian shall be noted in the log. Three copies of each photographic flight log shall be made. The original copy shall be retained by the navigator, one copy shall be attached to the can containing the film, and the other copy shall be forwarded to the Washington Office with the transmitting letter by separate mail. The index diagram on the back of the flight log should indicate any areas for which the coverage is questionable. Such areas will be indexed as soon as practicable after development of the film in the Office, and the navigator will be notified by radio where coverage is unsatisfactory when the airplane has not departed from the area.

In addition to the requirements for exposures developed in the field, three exposures (not to be used for mapping) are to be made at the beginning, and three at the end of each roll of single-lens film to allow for irregularities in machine development. Two exposures (not to be used for mapping) of nine-lens film at each end of the roll are sufficient for this purpose.

When photographing airports or revision areas of a few photographs each, two exposures for special test development should be made after each area is photographed, but the excess exposures for machine development as required in the preceding paragraph shall be taken only at the beginning and end of each roll. The beginning and end of photography likely to require special development shall be indicated by extra prick marks on the film and by notes in the photographic flight log.

Additional test exposures shall be made whenever opportunity offers, (as soon as practicable after arriving at a new project with terrain that differs markedly from that previously photographed) until the limiting light conditions under which satisfactory negatives can be taken, as well as the optimum exposures, have been determined. In Alaska, for example, suitable weather is so rare that the instructions authorize photography when the sun is less than  $30^{\circ}$  above the horizon. Although the apertures of the camera are opened to compensate for the weaker light, there may be areas on the northerly slopes of mountains, etc., in which shadows are so dark that they obscure detail. If opportunity offers during cloudy but bright or high overcast weather, it may be practicable to rephotograph such areas at larger scales from below the clouds. If the apertures of the lenses of the nine-lens camera are opened to  $f/68$  and exposures are made at less than 6,000 feet above the terrain, very useful images ordinarily will be obtained in cloudy but bright weather. Similarly, photographs of white sand beach show better detail when made in such weather or when the sun is quite low in the afternoon. The light meter readings for both optimum and minimum usable exposures for the various types of terrain are to be obtained by test exposures for each locality of extensive photography.

#### 244 CAMERA MAINTENANCE

Aerial cameras are precision optical surveying instruments and require the care that is used in handling and operating any similar instrument. Lenses and filters should be protected from damage and kept clean. No moving part should be forced to move—investigate any lack of proper freedom of motion and remove the cause. Avoid occasion for rough handling and do not place cameras where they may be knocked over or otherwise damaged. Daily routine inspection should be made to discover incipient causes of malfunctioning or breakdown.

##### *2441 Special Handling and Operation of Nine-Lens Camera*

The following instructions apply to maintenance and operation of the nine-lens camera, although some parts are applicable to single-lens cameras also.

(a) The camera, mirrors, lenses, and lens filters shall be inspected and cleaned *as soon as practicable after each photographic flight*. Salt spray or other corrosive solutions will destroy the evaporated aluminum coating of the mirrors if allowed to remain on them for long intervals. When not in use the entire camera, particularly the mirror and lens assembly, shall be kept covered with the special covers provided. The cleanliness of mirrors, filters, and lenses, the operation of the shutters and recording lamps, the setting of the lens stops, the winding of the watch, and records on the data card shall be inspected and attended to before each photographic flight.

(b) *Ample time* shall be allowed for inspection and maintenance, and the camera should be *handled slowly, gently, and carefully at all times*. Any shock or jar to the camera may disturb its adjustment and make accurate mapping from the subsequent photographs difficult or impossible. Both photographer and navigator shall be responsible for the care and maintenance of the camera.

(c) If the airplane has been standing in the rain or very damp foggy weather, it is desirable that its interior be dried out by portable heating or other devices if practicable. Shutter and other camera failures may result from excessive moisture freezing at photographic altitudes. The shutters should be operated (without winding the film) about every 2000 feet while climbing in temperatures below  $35^{\circ}$  F.

(d) The intervalometer of the nine-lens camera is operated by gearing which must finish its cycle to function. It is, therefore, necessary to use a special procedure at the beginning and end of photographic flights with automatically regulated exposure intervals to avoid poor coverage. The camera operator is on the same interphone circuit with the pilot and navigator. He will thus be able to judge when the airplane has reached photographic altitude from the conversation between navigator and pilot. He will then make a preliminary adjustment of the camera and take two exposures to assure that the

camera is functioning properly and to use up film which has been exposed to the distorting effects of varying temperature and humidity during the climb. He will stop the intervalometer about 4 seconds before it makes the third exposure. He will then be able to take the first exposure on automatic operation about 4 seconds after receiving the order to do so from the navigator. When completing a strip on automatic operation, the navigator will order the photographer to "Stop camera after next exposure." After that exposure has been made, the photographer will switch off the intervalometer 4 seconds before the next exposure. This shall be done by switching off the intervalometer motor the instant the 5-second signal light starts its flash.

(e) When approaching the shore at the end of a strip on automatic interval operation, the navigator will watch his camera exposure signal, and, if the last exposure does not fall within half a mile of the shore, another exposure shall be made as near the shore as practicable. If the winding cycle and restoration of the vacuum are not completed while the camera is still over the land, or there are steep slopes near shore, this exposure shall be taken over the water, but as near land as practicable. The order to the photographer will be, "Stand by for a pin-point," followed by *Take it* at the proper instant, or *Take a pin-point when ready* which will mean to make an exposure as soon as the vacuum gage indicates that the film is flat at the end of the winding cycle. When receiving either order, the camera operator should immediately shut off the intervalometer motor while mentally noting the time interval remaining until the next automatic exposure would have occurred. After the pin-point, or pin-points, have been taken and the winding cycles completed, he should then turn on the intervalometer motor and run it until the 5-second signal lamp starts to flash, thus placing the camera on the 4-second "stand by" position. The foregoing procedure is necessary in order to avoid a double or blurred exposure due to an undesired automatic *trip* which might occur before the film is sucked flat if the intervalometer is allowed to run while taking a pin-point. The procedure also assures that a photographic strip using automatically regulated intervals can be started in about 4 seconds after the order is received rather than after the longer interval which might otherwise be required for the camera to complete its cycle.

The foregoing applies particularly to the operation of the nine-lens camera but similar precautions are to be observed with other camera and intervalometer combinations when necessary to insure correct placement of the exposures without vacuum failure.

#### 245 FILM SHIPMENT

Film for mapping photographs shall be forwarded to the Washington Office for processing as soon as practicable after exposure, by railway express on government bill of lading if in the United States, or by air express, or the most rapid available transportation, if in Alaska. The transmitting letter shall contain a copy of the photographic flight log.

#### 246 REPORTS

(a) Changes of base of the aircraft and the limits of large areas photographed, shall be reported for operations in Alaska by routine radio at the end of the interval of good weather during which the photography is accomplished.

(b) Reports on the progress of photography and conditions encountered shall be made by air mail weekly.

(c) On the completion of the season, the navigator shall submit a Season's Report covering the operations, the work accomplished, the conditions affecting the progress and quality of the work, and recommendations for changes in procedure or instruments for similar work in the future.

#### 247 SPECIAL PHOTOGRAPHS

If the Supervisors of the U. S. Coast and Geodetic Survey Districts, or officials of the U. S. Coast Guard, or proper military or naval authorities contacted in the course



of the operations, desire special photographs, limited numbers of them may be taken if to do so will not interfere materially with the progress of the work. Requests which cannot be complied with without delaying regular assignments shall be referred to the Director by telegram.

## 25 FLIGHT PLANNING

The aerial photography for each photogrammetric mapping project is planned in accordance with the type of map to be produced, the characteristics of the area, and the method of compilation to be used. Specific instructions accompanied by flight maps are then issued by the Washington Office for the photography. The first step in flight planning is to select the aerial camera to be used. Theoretical considerations are given in **324**, the available cameras are described in **222** and **223**, and the selection of a camera for a particular kind of mapping is discussed in **251**.

### 251 SELECTION OF CAMERA

The nine-lens camera is preferable for practically all basic mapping of the coast (see **2111**) regardless of the type of map, with the possible exception of large-scale mapping of congested city waterfront areas where control is plentiful and the delineation of details must be limited to a narrow angle of view because of the height and congestion of buildings. Stereoscopic plotting instruments for nine-lens photographs are now in use and such photographs may be used for graphic plotting of planimetric maps or stereoscopic contouring. However, the laboratory output of nine-lens photographs is now limited by the fact that there is only one transforming printer. Many more photographs can be taken in a short period than can be processed in the laboratory in months, and pending the acquisition of a second transforming camera the nine-lens camera is used for practically all mapping photography in Alaska but in the United States for only an occasional area where the ground control is sparse or the control problem is particularly difficult. Consequently, much of the photography for coastal mapping in the United States is now taken with single-lens cameras.

The Fairchild cartographic camera with 6-inch metrogon lens is used for all photography for stereoscopic contouring with the multiplex or stereoplanigraph.

The Fairchild cartographic camera or the K-17 camera with 6-inch metrogon lens is used for photography to be used for planimetric mapping and for topographic mapping where contouring is by planetable, and where the compilation scale is 1:20,000 or smaller, except in congested harbor or city areas. The photographs are taken at a scale of 1:30,000 or 1:40,000 and enlarged to 1:20,000 for use in field inspection, planetable contouring, and compilation by radial-line methods. A 6-inch camera is also sometimes used for photography for 1:10,000 scale mapping of relatively open areas where control is an important consideration and details are not congested.

The K-17 camera with a 12-inch normal-angle lens is used for photography for planimetric mapping of harbor or city areas where control is plentiful and culture is congested. In these circumstances the definition of details is much more important than the coverage per photograph.

The cartographic camera is also used to a limited extent to take single-lens photographs for stereoscopic contouring of islands in Alaska at contour intervals of 50 or 100 feet. The flight altitude preferable for stereoscopic contouring is sometimes too high for the required

definition of shoreline details, so two sets of photographs are often taken—one set of complete coverage at high altitude for the contouring and a second set of the shoreline at lower altitude. In some cases, these shoreline photographs are taken with the K-17 camera with 12-inch lens.

## 252 FLIGHT MAPS

Flight maps are prepared for each aerial photographic project. The flight lines are drawn on the best available maps at a scale of about 1 inch to 2 miles, or approximately 1:125,000. At this scale, the coastline and adjacent topography can be seen in sufficient detail for the navigator's use in following the lines and the map is small enough to be handled conveniently in the airplane.

Up-to-date topographic maps or nautical charts, where available, are reduced photographically as necessary to provide flight maps at the scale of 1:125,000. Where large-scale maps or charts are not available, flight lines are necessarily laid out on small-scale maps or charts, and where the coastline or adjacent topographic features on these small-scale maps are incomplete or generalized, the flight lines cannot always be followed exactly and at times the maps must be considered merely as an indication of the coverage desired.

Most coastal mapping is of a zone adjacent to the coastline, and flight lines are necessarily arranged to parallel the coast. But where an inland area or a coastal area with considerable depth normal to the coast is to be photographed, the lines may be arranged in a north-south or an east-west direction.

The flight lines are carefully planned and laid out to provide photographic coverage of the shoreline and alongshore details, and at the same time to facilitate the photogrammetric plotting with reference to available ground control. All shoreline and alongshore details must appear on a minimum of two photographs. The coastline is rarely straight for any great distance and, consequently, flight lines are often short and broken, rather than long and straight.

The available ground control is diagrammed and preliminary plans for any needed supplemental control are made concurrently with the flight plans so that the flight lines can be laid out to utilize the control to the best advantage and to limit the supplemental control, and to facilitate the photogrammetric plots. In some areas control points are available just beyond the project limits and the photography is extended to include that control, and flight lines can sometimes be arranged so that a control station is midway between two flight lines and thus serves to control both.

Generally, there is a greater density of ground control stations along the shore than in any other part of a project area. Radial plots are stronger where the flight nearest the coastline is well inside of these shoreline stations rather than immediately over them. Consequently, where the coast is flat or gently sloping, the flight line nearest to the shore is placed well inside of the control, but so that no part of the shoreline or alongshore details is farther than halfway out on the wings of nine-lens photographs or three fourths of the distance from the center to the edge of single-lens photographs. This flight-line placement, where practicable, assures adequate definition of shoreline details and at the same time strengthens the photogrammetric plots. Along precipitous coasts, one flight line must be vertically above or just inshore from the shoreline, otherwise some shoreline details would be hidden by displacement of the alongshore bluff or cliff. For such conditions, additional flight lines are often specified so as to provide both for the photographic definition of details and for a strong geometric arrangement of the photogrammetric plots. Along some precipitous coasts, flight lines or single photographs are deliberately laid out over water areas for the sole purpose of obtaining adequate views of the shoreline.

Flight lines are actually spaced to comply with the side-lap requirements for the specific project and they are laid out on maps by use of the following formulas

$$W = \frac{w}{f} \times H \quad \text{and}$$

$$A = W(1 - s)$$

where  $w$ =width of photograph negative (usually 9 inches for single-lens),  $f$ =focal length of camera (in same unit as  $w$ ),  $H$ =flying height above average terrain,  $W$ =ground length of one side of square area covered by a single photograph (in same unit as  $H$ ),  $s$ =side lap (expressed in percentage), and  $A$ =ground spacing of flight lines (in same unit as  $W$ ) which is converted to map distance by applying the map scale

Insofar as practicable, flight lines are positioned so that they pass over major topographic features that can be recognized and used by the navigator to fly them exactly as indicated on the map

## 26 LABORATORY PROCESSING AND RECORDS

All aerial film is now processed in the Aerial Photographic Laboratory of the Division of Photogrammetry at Washington, D C

Each completed roll of film is shipped to Washington by the aerial photographic mission, properly identified on the outside of the can with a serial number which indicates its sequence and the letter designating the camera with which it was taken Accompanying this film is a copy of the "Photographic Flight Log" (Form No M-2621-12) on which are listed data noted by the navigator-at the time of exposure Included are the date of photography, time of day, location, approximate number of exposures, camera designation, and various navigational data such as compass heading, drift angle, altimeter readings, and factors which affect processing, such as exposure meter readings, visibility, occurrence of clouds, and the exposure times used Remarks are also included concerning the character of the terrain and about any test negatives that have been developed in the field

### 261 LABORATORY PROCESSING

From the data furnished on the Photographic Flight Log, a proper development is selected which will give the most effective rendition of details Development of aerial roll film requires special equipment because of the sizes and quantities of film involved Nine-lens film is processed in special large tanks through which the film is drawn by cranking it back and forth between spools of suitable length and diameter After development, the film is cut into separate exposures and thoroughly washed, and then placed on open plastic screen frames to dry naturally without any artificial treatment that might tend to distort the film

Single-lens film is processed in a specially designed motor-driven machine The film is wound back and forth between two vertical spools that are completely immersed in the solution The winding is done by an electric motor that automatically reverses the direction of movement each time the end of the film is reached The film is fixed and washed in the same machine and, after it has been washed, it is placed on a special drying machine that draws the film around the periphery of a cylindrical drum in the center of which a fan is placed The fan forces air outward from the center against the film and prevents damaging contact of the film against the surface of the drum while the film is wet and soft.

After having been dried, the film is returned to the original spool on which it was received and stored in the can. Single-lens film is not cut into individual exposures, the entire roll usually being stored intact.

## 262 INSPECTION AND INDEXING

After processing, all film is inspected for photographic quality, proper functioning of the camera, etc. It is indexed and carefully checked for overlap and placement of flight lines against the flight map furnished with the instructions for the photography. A report is prepared for each project or major subdivision of a photographic mission, so that the flight crew can be apprised of the outcome of their work and whether or not it complies with the specifications and instructions.

Nine-lens film is indexed on map bases by direct examination of the aerial negatives—prints are not made specially for indexing. The positions of the centers of photographs are spotted on the index base and numbers of the exposures are taken directly from the negatives where they are photographically recorded from the counter on the camera. Single-lens photographs are usually indexed from a preliminary set of contact prints specially printed for the purpose, and overlap and placement of flight lines are usually checked at the same time. If a fairly large area with a number of parallel flight lines has been photographed, a "shingle mosaic" index is usually prepared from this set of contact prints. Photographic copies of the mosaic serve as detailed indexes from which to select photographs of any part of the area. On single-lens film the exposure number, camera designation, date of photography, and other specific data are stamped by hand on each negative (see 156) with a rubber stamp. This information appears on every print subsequently made.

Smooth indexes at the scale of 1:250,000 are prepared on special map bases which normally cover 1° of latitude and 1° of longitude—for the higher latitudes of Alaska each index may include 2° or 3° of longitude. On these bases each line of photographs is shown, with the centers of the individual photographs indicated by dots, with numbers shown at convenient intervals, so that it is possible to select the exact print, or prints, to include any area. Separate indexes on the same bases are maintained for single-lens and nine-lens photography. Each index also lists the numbers and dates of the photographs that are indexed on it, together with the designation of the aerial camera used and the scales, so that appropriate selection may be made for any available coverage.

In addition to the index maps, master log books are kept which list each exposure by number, date, and camera designation, and in which are recorded such specific data as time of day, project number, area, and remarks about any peculiarities of any specific exposures. These log books provide a means of identifying any photograph solely by its number, which is impossible on the indexes unless the approximate area is known, and they often contain specific data which are helpful to the map compiler.

## 263 TYPES OF PHOTOGRAPHS

Requests for Bureau use for all aerial photographs from negatives owned by the Coast and Geodetic Survey are filled in the Aerial Photographic Laboratory, and, insofar as laboratory facilities permit, requisitions or orders for photographs from other federal agencies, State and local governments, and private organizations or individuals will be filled at the discretion of the Bureau.

The types of photographic prints furnished are

- (a) From nine-lens negatives
  - 1 Transformed prints on matte paper for field use
  - 2 Transformed prints on waterproof paper for radial plotting
  - 3 Transformed prints mounted on aluminum sheeting for high accuracy plotting
  - 4 Rectified prints mounted on aluminum sheeting for use on the Reading Plotter
- (b) From single-lens negatives
  - 1 Contact prints on matte paper for field use
  - 2 Ratio prints (enlargements) on matte paper for field use
  - 3 Ratio prints on waterproof paper for radial plotting
  - 4 Rectified prints for controlled mosaics and other special uses
  - 5 Diapositive prints (positive prints on glass) (a) 64 cm by 64 cm for multiplex mapping, and (b) 247 cm by 247 cm for mapping on the stereoplanigraph

## 264 PRINTING EQUIPMENT

Transformed prints from nine-lens negatives are made on a special transforming printer in which the nine separate images are optically projected and printed on one piece of photographic paper, with the junctions of the images matched and the original oblique wing chambers restituted to form component parts of a single wide-angle photograph (see 223 and 622). This printer reconstructs the angle of the oblique views and by oblique projection with differential enlargement transforms them into the plane of the center chamber. This requires a close calibration of the camera and the use of a number of minor corrective motions on the transforming printer to compensate for slight deviations of the adjustments of the nine-lens camera.

If the camera axis was not truly vertical at exposure, nine-lens transformed prints, like single-lens prints, have displacements due to tilt of the camera axis. If the airplane did not fly at constant altitude during a flight, the photographs do not have the same scale. For some processes, particularly contouring with the Reading Plotter, the photographs must be at the same scale and with tilt eliminated. This is achieved by printing from the original tilted *print* through a large projector, or rectifying camera, specially constructed for use with nine-lens photographs, in which it is possible to tilt the copy board, lens, and tilted print as desired and vary the projection distance by setting scales to precomputed positions so that the resultant projection print is at the desired scale and is the equivalent of an untilted photograph (see 623). Rectification of single-lens negatives is achieved by direct projection from the *negative* onto the copy board of a Zeiss SEG-4 automatic focus rectifier. On this rectifier the copy board, lens, and film holder have coordinated motions that automatically maintain correct adjustment for focus. The film is projected and varied by trial until the image is visually corrected.

Ratio prints (enlargements or reductions from the original size) are made by projection of the negatives in a Saltzman precision projector on which any desired ratio within the limits of the instrument is obtained by setting the lens and film holder to their proper distances by setting to precomputed positions on scales.

Diapositive plates (positive prints on flat glass) are made for multiplex mapping by reduction in a special multiplex diapositive printer which reproduces from the original negative at the exact reduction desired. In this printer the lens system is designed to compensate for inherent distortion in the metrogon lens (see 631). Diapositive plates for the stereoplanigraph are produced either by direct contact printing from the original negative or by 1:1 ratio projection printing in the Saltzman projector.

## CHAPTER 3. PHOTOGRAMMETRIC THEORY

This chapter deals with the theoretical principles that form the basis of many of the practices used in photogrammetry. The purpose is to explain to the photogrammetrist the fundamental reasons underlying his activities, to give him a well-founded basis for understanding the entire field of photogrammetry, to impress on him that the practice and theory of photogrammetry are far from being fully exploited, and to encourage him to study further into the many problems.

The theory is explained largely by simple mathematics. The mathematical approach is necessary because a photograph is a practical application of geometry which requires solutions involving graphic construction or algebra, trigonometry, and analytic geometry. As stated by Professor Earl Church, "Mathematical analysis provides an effective means of teaching the fundamental theory of photogrammetry." In fact, without the tool of mathematics, one's understanding of photogrammetry might be cumbersome and limited.

An attempt is made to employ the simplest analysis practicable so that the text can be understood by the high school graduate. The reader must have an introductory knowledge of trigonometry, further mathematical background is helpful but not essential.

This chapter contains more material than is generally utilized in practice. The considerations that are involved in making planimetric maps from vertical photographs are in sections 31, 32, 33, and part of 34. The material through section 36 affects the making of topographic maps. Section 37 consists of an introduction to the use of horizontal and oblique photographs.

### 31. OPTICAL PRINCIPLES

Geometric optics is discussed here with sufficient completeness for the understanding and development of subsequent principles of photogrammetry. The subject is considered more fully in the Manual of Photogrammetry (American Society of Photogrammetry) and in the Fundamentals of Optical Engineering<sup>1</sup>. A more thorough knowledge of optics is required for the design of optical instruments and for many research problems.

#### 311 THE FUNCTION OF A LENS

Photogrammetric mapping depends on the use of lenses for many of the various steps for taking the original photographs, for ratio printing, for transforming or rectifying, for reproducing photolithographic plates, and for aiding the human eye in viewing photographs and maps. In each of the steps except the last one, the lens forms a real image of predictable dimensions on a plane surface located in a definite position. In the last step the lens operation is such that when it is used in conjunction with the human eye, a real image is formed on the retina (331).

#### 312 THE IDEA OF LIGHT RAYS

In photography the object is considered as being composed of a group of many minute points. Each object point is regarded a source of illumination, projecting rays of light in all directions in divergent and radiating straight lines. Every point not in the object (such as the pinhole of a pinhole camera) lies in the path of one ray of light from each object point. Every *area* not in the object (such as the opening of a camera lens) lies in the paths of *many* of the divergent rays of light from each object point. The rays from a single object point to a lens form a cone of rays having the lens for its base and the object

<sup>1</sup> Jacobs, Donald H., Fundamentals of Optical Engineering, pp. 1-90

point for its apex. The rays of this cone are deflected by the lens in a systematic manner so that they reunite in a single, definite, distinct point called the image. The cones of rays from all the other object points also simultaneously converge into their respective distinct image points without interfering with one another.

### 313 THE LENS-PINHOLE ANALOGY

A photograph made with a small pinhole aperture having no glass parts is a criterion for the geometric performance of a lens. The obvious objection to the use of a pinhole camera is the long time that is required (5 minutes is not unusual) for the small amount of light to cause the necessary change in the photographic film. The exposure time supposedly could be shortened by employing a larger pinhole, but this results in a lack of image sharpness (resolving power or definition). If a pinhole can be regarded as admitting but one ray of light from each object point, then a larger hole would admit many divergent rays which would continue to diverge until intercepted by a screen or film. The image of the object point would then consist of an illuminated area instead of a single point. A lens is used to cause the cone of rays to converge to a point image at the same place where the image would be formed by a small pinhole. Hence, a lens is a device that causes sharp images to be formed in the identical positions obtainable with a pinhole, and at the same time admits a sufficient amount of light in a very short time to sensitize photographic film.

### 314. SNELL'S LAW OF REFRACTION

Snell's law for the refraction (deflection) of a ray of light on passing from one transparent material or medium, such as air, into another medium, such as glass, can be expressed in part by the equation

$$\frac{\sin i}{\sin r} = n \quad (314A)$$

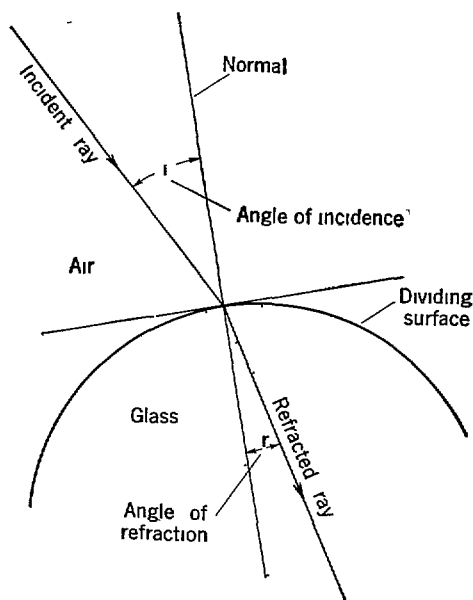

FIGURE 31—Refraction of a ray of light

which  $i$  (fig 3 1) is the angle of incidence measured from the incoming ray to the line (normal) that is perpendicular to the dividing surface between the two mediums at the point of contact,  $r$  is the angle of retraction measured from the outgoing ray to the normal, and  $n$  is the index of refraction of the second medium divided by the index of the first (The index for air is one ) The index is a constant value for the same two mediums for all pairs of values of  $i$  and  $r$  The law also states that the incident ray, the normal, and the refracted ray lie in the same plane The value  $n$  can also be expressed as the velocity of light in the incident medium divided by the velocity of light in the refracted medium The principle of refraction is the basis for the design and the operation of all lenses

315 THE SIMPLE LENS LAW

A symmetrical double convex lens is perhaps the simplest type of photographic lens, reading glass, and magnifier It is considered here because of simplicity of illustration, but the reader should realize that there are a multiple of possible shapes and complexities which in practice frequently enter into the design and construction of a lens to be used for such

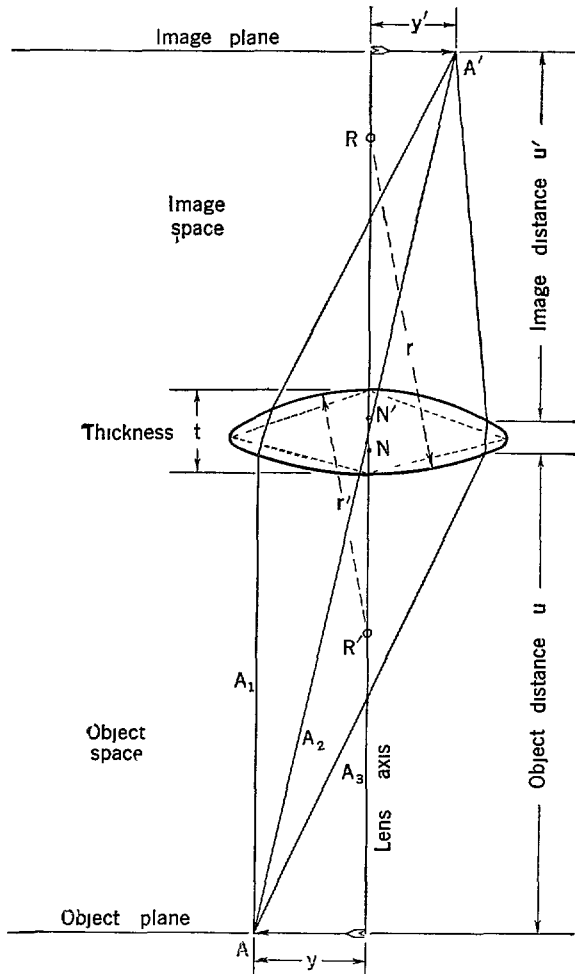

FIGURE 3 2—Image formation with a simple lens



comparatively simple purposes. A lens is a piece, or a combination of pieces, of glass or other transparent material shaped so as to bend rays of light systematically in a desired manner by means of refraction. A double convex lens may be visualized (see fig. 32) as operating somewhat as if it were composed in cross section of two glass wedge prisms placed with their thicker edges together. A wedge prism deflects a traversing ray of light toward its thicker side in accordance with Snell's law. It is practicable to grind a lens surface either spherical or plane, and it is extremely difficult to grind any other regular surface.

Figure 32 shows a sectional view of a double convex lens. The part of the figure below the lens is here called the object space, and that part above the lens is called the image space. (In most enlarging cameras the system is inverted.) Light rays are regarded as originating in the object space, as at  $A$ , and passing upward through the lens to the image space. The object  $A$  is the source or apex of a cone of light rays of which only three are indicated,  $A_1$ ,  $A_2$ , and  $A_3$ . The point  $R$  is the center of the sphere of which the first or lower lens surface is a part.  $R'$  is the center of the sphere which contains the second lens surface. The radii of the spheres are  $r$  and  $r'$ , respectively, and are not necessarily equal. The line  $RR'$  connecting the centers of the spheres is called the lens axis. The two nodal points  $N$  and  $N'$  are discussed in 316, but for the present they are considered as being so close together that they can be regarded as a single point at the center of the lens. The distance  $u$  from  $A$  to the lens is called the object distance and is always measured parallel to the lens axis. Similarly  $u'$  is the image distance from the lens to the image, measured parallel to the lens axis. It should be apparent that the distance  $u'$  from the lens to the reintersection  $A'$  of any two rays of the cone of rays is a definitely fixed quantity. The value can be computed somewhat like a traverse in surveying, using Snell's law to obtain angles of deflection and using the quantities  $n$ ,  $y$ ,  $u$ ,  $t$ ,  $r$ , and  $r'$  as known values. If  $y$  and  $t$  are small relative to both  $u$  and  $u'$ , it can be shown that

$$\frac{1}{u} + \frac{1}{u'} = (n-1) \left[ \frac{1}{r} + \frac{1}{r'} - \frac{t(n-1)}{nr'r'} \right] \quad (315A)$$

(No attempt is made to set up a convention as to algebraic signs. Hence  $r$ ,  $r'$ ,  $u$ , and  $u'$  are all regarded as positive values, and the formula as it stands does not then apply to any other than a double convex lens.)

The relation is derived from figure 32, using only geometry, trigonometry, and algebra. It should be noted that the value  $y$  does not appear in the equation, and that all the terms of the right side of the equation are constant values related only to the shape of the lens and the index of refraction of the glass.

Where the lens thickness  $t$  is very small, the relation is expressed more simply

$$\frac{1}{u} + \frac{1}{u'} = (n-1) \left( \frac{1}{r} + \frac{1}{r'} \right). \quad (315B)$$

Equation 315A is often used for approximate computations. It may be further simplified to its most common form by representing the entire right side by the term  $\frac{1}{f}$ , or

$$\frac{1}{u} + \frac{1}{u'} = \frac{1}{f} \quad (315C)$$

This equation is variously known as the simple lens law, the thin lens formula, and the conjugate foci law.

The quantity  $f$  in equation 315C is the focal length of the lens—a value which is determined by the shape of the lens and the kind of glass. Where the object distance  $u$  is very

large (100 or more times the image distance) the first term of equation 315C is essentially equal to zero, whence  $u' = f$ . For this reason an aerial mapping camera has a fixed cone which supports the lens at a constant distance  $f$  from the film. This principle also provides a quick method for a rough determination of the focal length of a lens: a lens and a screen are supported so that the screen (such as a piece of white paper) is perpendicular to the lens axis and so that a sharp image of a distant object (the sun, or a building across the street) is formed on the screen, the distance from the lens to the screen is the focal length.

Equation 315C can be rearranged by algebra to yield the following useful forms

$$u = \frac{u'f}{u' - f}, \quad (315D)$$

$$u' = \frac{uf}{u - f}, \quad (315E)$$

$$f = \frac{uu'}{u + u'} \quad (315F)$$

*Example 1* A photographic lens of 10-inch focal length is placed 60 inches from a copy board. Compute the proper distance at which the film should be placed to obtain sharp focus images.

Solution Using equation 315E,

$$u' = \frac{60 \times 10}{60 - 10} = 12 \text{ inches}$$

*Example 2* A lens that is supported at a distance of 10 feet from a target forms a sharp image of the target on a white screen 8 inches away. Compute the focal length of the lens.

Solution 10 feet = 120 inches. Using equation 315F,

$$f = \frac{120 \times 8}{120 + 8} = 7.5 \text{ inches}$$

### 316 NODAL POINTS

The development of the simple lens law was based on the assumption that the lens thickness  $t$  was a small value. In practice, however, a lens is composed of several variously spaced elements each of which has a thickness that cannot be ignored. Hence, the lens center is not a valid point from which to measure the object and image distances  $u$  and  $u'$  for use in equation 315C. Instead, two points  $N$  and  $N'$ , called nodal points, (see fig. 3.2) on the lens axis are used. Their positions relative to some definite lens surface or to some part of the lens mounting are usually determined experimentally and can be computed. The two points are so located that if the object distance is measured from one of them and if the distance to the sharp-focus image is measured from the other, then equation 315C is valid, even for a complicated lens assembly of several elements considered just like a simple lens. Incidentally, if a lens is rotated about its image nodal point, the image positions remain stationary.

The nodal points are sometimes reversed from their seemingly logical order, and sometimes they lie entirely outside the lens assembly. The nodal points of a simple symmetrical convex lens are usually situated about one-third the thickness of the lens inside the respective front and rear surfaces. The image nodal point of a telephoto lens is usually located in front of the lens assembly, thus enabling the use of a long focal-length lens with a relatively short camera assembly.

### 317 MAGNIFICATION

The term magnification has two specific definitions of importance.

1. Lateral linear magnification, or simply linear magnification, is the term which is usually associated with photography. It is defined in optics as a lateral dimension  $y'$  in

the image (see fig 32) divided by the corresponding dimension  $y$  in the object where the object dimension is in a plane perpendicular to the lens axis, or

$$m = \frac{y'}{y} \quad (317A)$$

From the similar triangles in the figure, it is apparent that the equation can also be expressed

$$m = \frac{u'}{u} \quad (317B)$$

Where the object and image are of equal size,  $m$  equals one, where the image is larger than the object, as in photographic enlargement, then  $m$  is greater than one, and where the image is smaller than the object, as in an aerial photograph,  $m$  is less than one

Equation 317B is frequently combined with 315D and 315E by algebraic substitution to yield the following useful forms

$$u = f \left( 1 + \frac{1}{m} \right), \quad (317C)$$

$$u' = f(1 + m) \quad (317D)$$

*Example* The focal length of a photographic enlarger is 10 inches. Compute the distances from the negative to the lens and from the lens to the easel to yield a sharp-focus enlargement of  $2\frac{1}{2}$  diameters

*Solution*  $m = 2.5$  Using equations 317C and 317D,

$$u = 10 \left( 1 + \frac{1}{2.5} \right) = 14 \text{ inches}$$

Fourteen inches is the distance from the negative to the lens (the negative is the object in this application)

$$u' = 10(1 + 2.5) = 35 \text{ inches}$$

2 Angular magnification applies to seeing and is used with reference to certain optical instruments where the object and image distances are not readily measurable. Angular magnification refers to the size an object *seems* to have to the eye using an optical device, contrasted with the apparent size when not using the device. For a simple magnifier the magnification  $M$  can be expressed as

$$M \text{ (in diameters)} = \frac{10}{f \text{ (in inches)}} \quad (317E)$$

where  $f$  is the focal length of a magnifier lens in inches and the magnifier is placed at the distance  $f$  from the object. Magnification is also expressed in diopters

$$M \text{ (in diopters)} = \frac{1}{f \text{ (in meters)}} \quad (317F)$$

*Example* Find the focal length of a magnifier lens that will create an apparent magnification of four diameters

*Solution*  $f = 2.5$  inches. From equation 317E,

$$f = \frac{10}{M} = \frac{10}{4} = 2.5 \text{ inches}$$

### 318 LENS ABERRATION

Lens aberration is the failure of a lens to produce a perfect image in correct position. The various types of aberrations may be divided into two principal categories (1) those

that cause lack of image definition, and (2) those that cause image distortion. The underlying reasons for the inability of a lens to duplicate the theoretical performance of an ideal pinhole are

(a) Image rays passing through different parts of a spherical-surface glass lens do not intersect at a point

(b) Even if image rays did intersect at a point, image positions do not change uniformly with changes in object positions

(c) The white light used in aerial photography is composed of all the colors, whereas the index of refraction of glass is different for each of the colors (dispersion)

(d) Lens manufacture is limited to the use of spherical surfaces

(e) Lens manufacture is limited to the use of a relatively small group of refractive materials

Lens aberration can be combated by the lens designer by altering several variables. The designer may choose

(a) The number of elements

(b) The radius of curvature of the surface of each element

(c) The thickness of each element

(d) The spacing of the elements

(e) The arrangements of the elements

(f) The index of refraction of the glass of each element—the angular deflection through which a ray of light is bent upon entering the glass

(g) The dispersive power of the glass of each element—the relative width of the spectral band into which glass spreads a beam of white light (a characteristic which is somewhat independent from index of refraction)

(h) The diameter of each element

(i) The placement and sizes of stops or traps for stray light

### 319 THE AERIAL CAMERA LENS

The aerial camera lens is perhaps the ultimate in lens design and places the greatest demands on the lens designer. Four features are of great importance: (a) sharp image definition (resolving power), (b) small distortion, (c) high speed, and (d) wide angular coverage. It can be said that the features are all mutually inconsistent, as the accomplishment of any one feature imposes obstacles against the realization of each of the others.

Image definition (resolving power) is expressed as the maximum number of lines per millimeter that a lens is capable of reproducing under laboratory conditions. A typical number is 50 lines per millimeter at the center of the angular field, decreasing to 20 lines near the edge. This is consistent with the grain of the photographic emulsion, aircraft motion, and camera vibration. Image definition is considered of very great importance.

Lens distortion can be made essentially zero with narrow angular fields and slow lens speeds. Characteristic amounts for a wide angle lens are zero at the center of the field, +0.05 mm at half the angular field, and -0.10 mm near the edge of the field. Lens distortion usually does not affect the compilation of planimetric maps but is highly important in the determination of elevations from photographs.

Lens speed is expressed in terms of the  $f/$  number in the formula

$$f/\text{ number} = \frac{\text{focal length}}{\text{lens diameter}}$$

*Example* If a camera lens has a focal length of 6 inches and if the largest effective stop opening is  $1\frac{1}{4}$  inches, then  $f/\text{no} = \frac{6}{1.25} = 4.8$  and the lens speed is said to be  $f/4.8$ .

Hence, lens speed is definitely related to lens diameter which controls the amount of light available for sensitizing the photographic material. A small  $f/$  number indicates a

large diameter and a fast lens. The use of a large-diameter lens as related to the focal length is often associated with troublesome lens aberrations. A speed of  $f/6.3$  is common for an aerial camera lens. Slower speeds are scarcely usable because of high aircraft speeds and the necessarily short exposure time.

Angular coverage affects the cost of ground control as the cost is nearly proportional to the number of photographs. Also, because map requirements and physical limitations fix the flight altitude, the only remaining device for reducing the number of photographs is to increase the angular coverage of each photograph by increasing the angular coverage of the camera lens. Many amateur cameras have a total angular coverage of  $50^\circ$ . The aerial camera lens of about the year 1935 had a coverage of about  $70^\circ$ . The present wide-angle lens has an angular coverage of about  $90^\circ$ . Experimental work is now in progress to produce a lens of  $120^\circ$ .

An aerial camera lens is designed to function well under a certain specific condition—at an infinitely great object distance. It would probably perform very poorly under any other condition. Similarly, lenses are designed for other specific uses and operating conditions, such as for a ratio printer. Varying emphasis is placed on the different lens characteristics, with speed and angular field usually being less important for stationary cameras than for aerial cameras.

The National Bureau of Standards is prepared to test any lens to determine its optical characteristics under specific laboratory conditions. A report is made of the findings as to resolving power, angular field, distortion, focal length, and back focal length (the distance from the rear lens surface to the image plane).

## 32 THE VERTICAL AERIAL PHOTOGRAPH

A vertical aerial photograph is a photograph taken from an aircraft with the lens axis of the camera in vertical alignment or as nearly vertical as practicable. This section considers photographs in which there is *no* deviation of the lens axis from the vertical—photographs that are not tilted at all.

### 321 COMPARISON OF A PHOTOGRAPH WITH A MAP

A photograph is a perspective projection. Consider any array of points. If a line passes through each point and also through a single common point, then the group of lines is a perspective group of lines and the common point is called a perspective center. If a plane intersects the group of lines, a distinct point is determined in the plane where each of the lines intersects it. This second group of points is related perspectively to the first group of points through the perspective center. The second group is called a plane perspective projection of the first group, or simply a perspective projection. Obviously, an aerial photograph fits this description of a perspective (see 312 and 313). Ground objects correspond to the first group of points, the pinhole, or the image nodal point of the lens, corresponds to the perspective center, and the photographic images correspond to the second group of points. A photograph is a record of the perspective bundle of light rays on an intersecting plane and hence is called a perspective projection, in contrast to an orthogonal projection.

A few well-established mathematical principles of projectivities are particularly noteworthy in their applications to all photographs, vertical and oblique.

(a) Only one image exists on a photograph for each object point.

(b) Any straight line in the object appears as a straight line on any photograph. A road is considered a straight object line if no curves are in it and if it is of constant slope. If a line is drawn

on one photograph connecting two images of equal elevation, and if a line is drawn connecting the corresponding two images on any other photograph, then each of the two lines also passes through all the same intermediate corresponding images whose objects are of that same elevation

(c) If a series of at least four images lie on a line in one photograph, and if the corresponding images lie on a line in any other photograph, then there exists a very definite harmonic relation between the two systems of line segments. The development of this idea is beyond the scope of this writing.

(d) A photograph that has been properly copied, recopied, ratio printed, and/or properly rectified is still theoretically a simple perspective projection. The same arrangement of images might be obtained on an original photograph taken from the same perspective center with a proper focal length camera and with a proper camera inclination.

A large-scale map can be regarded as an orthogonal projection. A small area of the earth's surface (such as usually appears on a vertical aerial photograph) can be considered as having an imaginary flat datum plane or reference plane, earth curvature being regarded as negligible. A point on the datum plane vertically beneath an elevated object is said to be the *orthogonal* projection of the object, the word orthogonal implying that the line of projection is orthogonal (perpendicular) to the plane of reference. If all prominent objects in an area are thus projected onto their datum plane, and then this plane is shrunk or reduced uniformly until it is a desired size or scale, the result is called a map.

It is the function of the photogrammetrist to construct orthogonal views from perspective views or, more specifically, to make maps from photographs.

The vertical aerial photograph is preferred for map making because it resembles a map more closely than does a photograph taken with any other inclination of the camera axis, and because the theory and practice of map making from vertical photographs is comparatively simple.

The comparison of a photograph with a map reveals that many photographic images are not in their correct relative positions, whence the images are said to be displaced. The displacement may be attributed to several component factors, some of which result directly from the fact that a photograph is a perspective. The component displacements are due to

- (a) Flying height (scale)
- (b) Elevations of the objects
- (c) Tilt of the aerial camera
- (d) Uneven film and paper shrinkage
- (e) Lens distortion

Conversely, a photograph and the map would be identical if

- (a) The photograph were exposed from exactly the correct flying height
- (b) All objects were of equal elevation
- (c) The plane of the film were exactly parallel to the datum plane
- (d) The photographic materials were dimensionally stable, such as glass plates for the camera and metal-mounted prints
- (e) The lenses of the camera and the printer were both free from optical distortion

If the photogrammetrist understands how these factors operate, he should be able to apply more intelligently the various techniques used in making accurate maps from photographs. The last two items are discussed in 4213 and 318, respectively.

## 322 SCALE, FOCAL LENGTH, AND FLYING HEIGHT

### 3221 *The Scale of a Map*

The scale of a map is a numerical fraction that indicates the relation of dimensions, shown on the map to the corresponding actual dimensions of the part of the earth's surface depicted. The same principle is employed in stating the scale of a patent model, a work of

sculpture, or a mechanical drawing. For example, a patent model may be one-fourth scale which means that the model is one-fourth the actual size of the machine or that the actual machine is four times the size of the model. Furthermore, each and every item on the actual machine is four times as large as the corresponding item of the model. Similarly, if the scale of a map is 1/40,000 it implies that the map is one forty-thousandth the size of the ground it represents and that the ground is 40,000 times the size of the map. The fraction is called the *representative fraction* (R F) and is also written 1/40,000, to be read as "one to forty-thousand." It is obviously implied that each and every feature, such as a factory building, is 40,000 times as large as it appears on the map (except where the map feature is so small that it is represented by a standard symbol). The expression is often

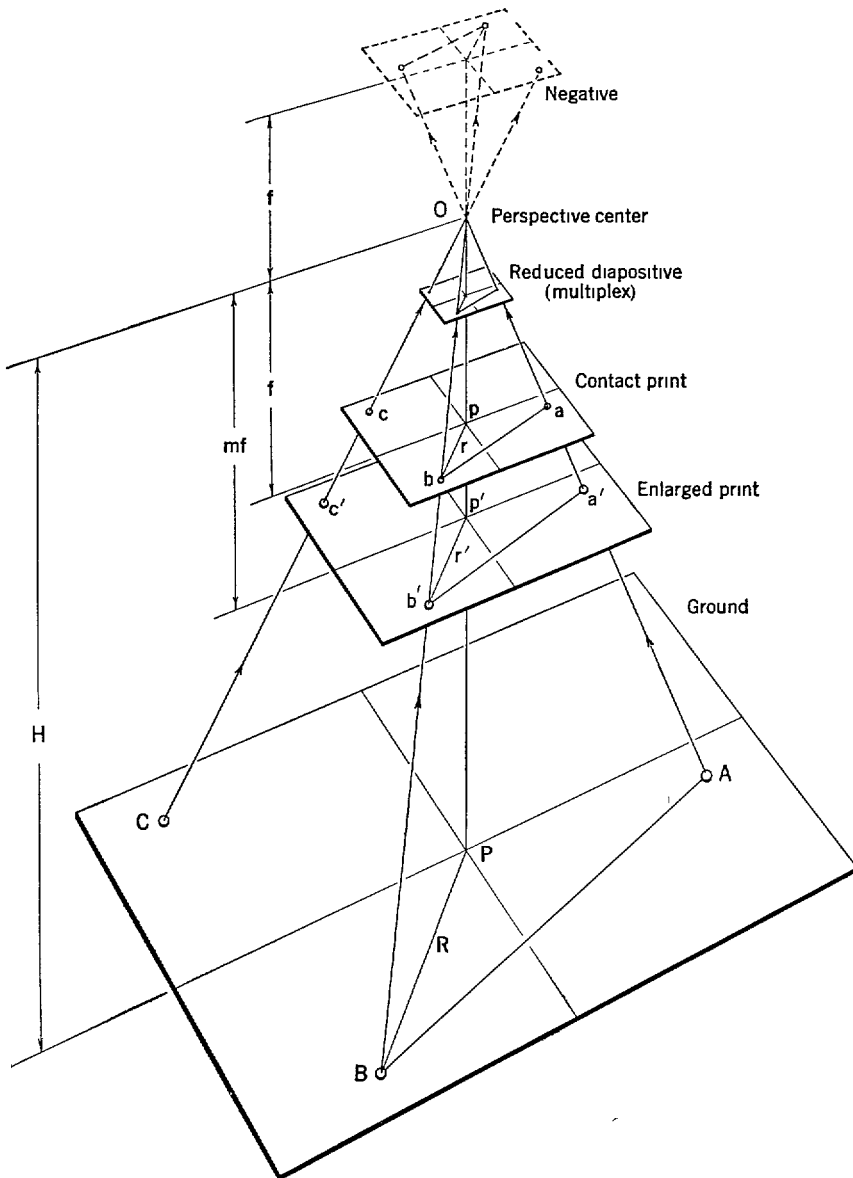

FIGURE 33—The perspective relation of the various forms of a photograph

shortened in conversation to "40,000 scale" or "40,000-scale map" to mean a map having the scale of 1 40,000

The scale of a map can be expressed algebraically as

$$S = \frac{ab}{AB} \quad (3221A)$$

where the scale  $S$  is usually (but not necessarily) in the form of a representative fraction having the numerator *one*,  $AB$  is the distance between the two objects  $A$  and  $B$  on the earth's surface (see fig 3 3) and  $ab$  is the distance on the map between the two corresponding points  $a$  and  $b$ . It is important that the values of  $AB$  and  $ab$  be expressed in the same units of measurement. To ensure that  $S$  has the numerator *one*, the expression can be rearranged to the form

$$S = \frac{1}{\frac{AB}{ab}} \text{ or } 1 \frac{AB}{ab} \quad (3221B)$$

which is frequently a more useful expression

*Example* What is the scale of a map if the distance between two points is 3 inches on the map and it is known that the two points are 1 mile apart on the ground?

*Solution* Express the ground distance in inches

$$\begin{aligned} 1 \text{ mile} &= 5280 \text{ feet} \\ &= 63,360 \text{ inches} \\ S &= 1 \frac{AB}{ab} = 1 \frac{3}{63,360} \\ &= 1 \frac{1}{21,120} \text{ or } \frac{1}{21,120} \end{aligned}$$

Because a photograph is usually not a map, it does not have a scale, strictly speaking, but rather it has many different scales. Due to the resemblance of a photograph to a map, however, it is customary to express the average or apparent photograph scale in the same manner as for a map.

The scale of a map is said to be large or small with regard to the relative value of the scale fraction. For example, the scale 1 20,000 is larger than the scale 1 30,000 because if they are changed to decimal form,  $1 \frac{1}{20,000} = 0.000050$  and  $1 \frac{1}{30,000} = 0.000033$ . The decimal form is used occasionally in certain computations.

### 3222 Scale Relations of a Photograph

Equations 317A and 317B are recalled and written in the combined form

$$m = \frac{y'}{y} = \frac{u'}{u} \quad (3222A)$$

The derivation was based on optics, similar triangles, and the implications that the object and image dimensions  $y$  and  $y'$  were parallel lines and also that they lay in planes perpendicular to the lens axis (see fig 3 2).

Figure 3 3 illustrates the relationship of a vertical aerial photograph to the ground where the perspective center is at  $O$  and the camera has a focal length of  $f$ . The camera unit and the negative are shown from  $O$  upward. Inasmuch as the contact print is used so universally, it is represented at a distance  $f$  below  $O$ , in its correct theoretical position. (A print that is identical to a contact print can be produced with a ratio printer at a ratio or magnification of  $m = 1$ .) The line  $Opp'P$  is the lens axis and it is truly vertical. The



point  $p$  is the principal point of the contact print and the point is usually located at the geometric center of the photograph. The ground plane  $ABC$  is truly horizontal, and also the plane  $abc$  of the contact print is horizontal. It is not necessary to consider further the part of the figure above  $O$  and hence it will not be shown on subsequent diagrams.

It is apparent in figure 3.3 that  $ab$  corresponds to  $y'$  in equation 3222A, also  $AB$  corresponds to  $y$ ,  $f$  corresponds to  $u'$ ,  $H$  to  $u$ , and  $S$  to  $m$ , or

$$S = \frac{ab}{AB} = \frac{f}{H} \quad (3222B)$$

The same relation can be obtained independently from equation 3222A by observing that the triangles  $Oab$  and  $OAB$  are similar, that their altitudes are  $f$  and  $H$ , respectively, and that equation 3222A applies.

In equation 3222B,  $H$  is used to designate the distance from the reference plane to the perspective center. In practice,  $H$  always designates the flying height of the aircraft above sea level, which is identical to assuming that the reference plane is always the sea level datum plane. As many objects occur at elevations other than sea level, it is convenient to use  $h$  as the elevation of the reference plane  $ABC$  above sea level. Then the object distance  $OP$  is the difference  $H - h$  and equation 3222B is re-written in the form

$$S = \frac{ab}{AB} = \frac{f}{H - h} \quad (3222C)$$

This dual equation can be used in many ways. Wherever  $S$  is involved, all other terms must be expressed in the same units of measurement.

The first part of equation 3222C is identical to equation 3221A and can be used in the same way as illustrated in the example in 3221. Where the object points  $A$  and  $B$  have different elevations, the equations do not apply exactly but, nevertheless, they are frequently used for determining an approximate scale value by letting  $h$  be the average elevation of two objects. Where the best value of the approximate scale of a photograph is desired, it is preferable to use the average scale obtained by measuring two relatively long lines that intersect near their midpoints (see fig. 3.4) at about right angles near the principal point.

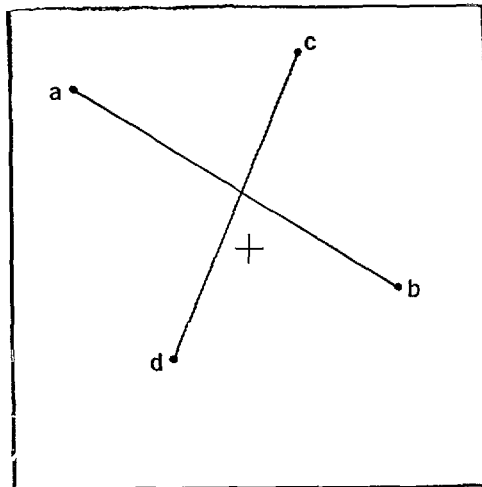

FIGURE 3.4—Acceptable arrangement of points for determining the approximate scale of a photograph

*Example 1* The lengths of two lines on a photograph, as *ab* and *cd* in figure 34, are measured as 4152 mm and 3597 mm, respectively. The ground distances *AB* and *CD* between the corresponding objects are known to be 28,263 feet and 23,580 feet, respectively. Find the scale of the photograph.

*Solution* Changing all distances to meters

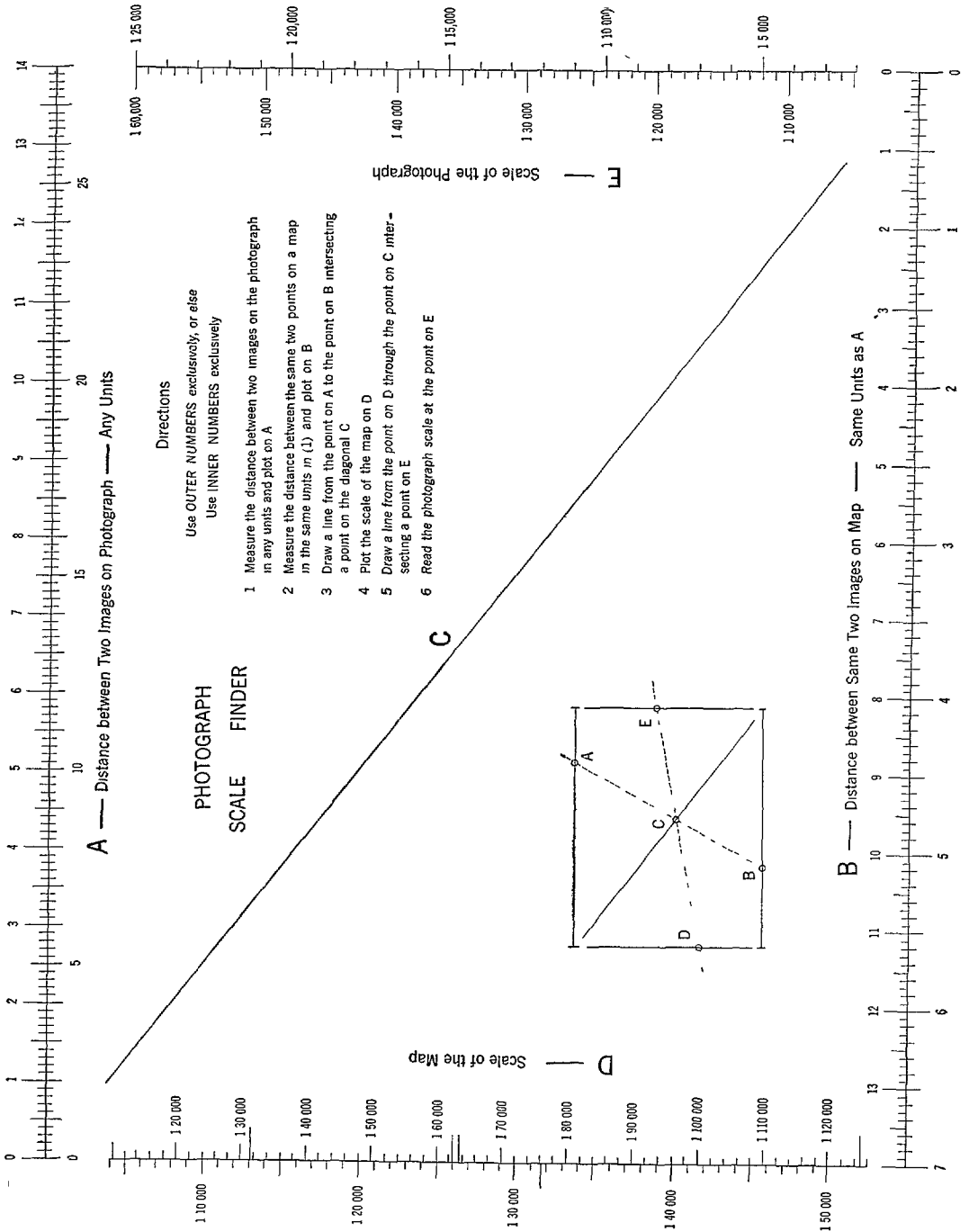

FIGURE 35 —Nomograph for determining photograph scale from a map

$$\begin{aligned} ab &= 0.4152 \text{ m} & cd &= 0.3597 \text{ m} \\ AB &= 28,263 \times 0.30480 = 8614.6 \text{ m} \\ CD &= 23,580 \times 0.30480 = 7187.2 \text{ m} \end{aligned}$$

$$\text{Scale of } ab = 1 \frac{AB}{ab} = 1 (8614.6 - 0.4152) = 1 \text{ 20,748}$$

$$\text{Scale of } cd = 1 \frac{CD}{cd} = 1 (7187.2 - 0.3597) = 1 \text{ 19,981}$$

The scale of the photograph is the average of the two scale numbers, or 1 20,364

*Example 2* The distance between two points on a photograph is 5.11 inches. The distance between the corresponding two points is 285 inches on a map whose scale is 1 40,000. What is the scale of the photograph?

*Solution* Inasmuch as distances between corresponding points on maps of different scales are proportional to the values of the representative scale fractions of the maps,

$$\begin{aligned} \frac{S}{1} &= \frac{5.11}{285} \\ \frac{1}{40,000} & \\ S &= \frac{1}{40,000} \times \frac{5.11}{285} = \frac{1}{40,000 \times 285} \\ & \qquad \qquad \qquad \frac{5.11}{5.11} \\ S &= \frac{1}{22,309} \text{ or } 1 \text{ 22,309} \end{aligned}$$

A nomograph (see fig. 35) can be used if problems similar to *example 2* are to be solved repeatedly. The nomograph is available in the Washington Office.

*Example 3* The focal length of a photograph is 210 mm, the distance between two images is 322.7 mm, and the flying height is 14,000 feet above sea level. If the two objects were at an elevation of 1000 feet, what is the ground distance between them in feet?

*Solution* From the second part of equation 3222C,

$$AB = ab \frac{H-h}{f} = 322.7 (14,000 - 1,000) \div 210 = 19,977 \text{ feet}$$

The unit of measurement of  $AB$  is the same as that of  $(H-h)$  if the unit of  $ab$  is that of  $f$ . The two sets of units need not be the same in the type of problem that utilizes only the last two parts of equation 3222C.

### 3223 Ratio Print, Definition

Figure 33 illustrates the fundamentally correct relation between a ratio print and the contact print. A ratio print is an enlarged or reduced copy of the magnification ratio  $m$  produced by optical-photographic methods from a negative of focal length  $f$ , the print being exactly equivalent to that which could have been made originally from the same perspective center with a camera of focal length  $mf$ . It might be argued that the ratio print could have been obtained equally well with the same camera but from a different perspective center of elevation  $H - m$ . This is true only if all the objects are of equal elevation. The principle is discussed more fully in 3232 and 3241.

The scale of a ratio print of an aerial photograph therefore depends on only the flying height of the aerial camera and the subsequent ratio of enlargement, and is independent from the focal length of the aerial camera. Various practical limitations affect the freedom of choice of flying height, focal length, and ratio of enlargement. These topics are discussed more fully in 324.

### 3224 Displacement of Images Due to Scale

Images are displaced due to a scale difference along lines that pass through the principal point of a truly vertical photograph. In other words, the angular arrangement of the

images relative to the photograph center is not disturbed in any manner by ratio printing or by an error in flying height. The principle is obvious and no proof is cited.

The amount of displacement  $d_s$ , due to a difference in scale alone is defined as (see fig 3 3)

$$d_s = r' - r \quad (3224A)$$

and can be expressed as

$$d_s = r(m - 1) = r'(1 - \frac{1}{m}) \quad (3224B)$$

where  $r$  is the distance from the principal point to the image on a given photograph,  $r'$  is the corresponding distance on a ratio print (or on a map if there is no relief), and  $m$  is the scale  $S'$  of the ratio print or map divided by the scale  $S$  of the given print,  $m = S' - S$

Equation 3224A can be derived from figure 3 3. Although the planes of the contact print and the ratio print are used, the procedure is identical for any other two planes. Consider the points  $b$  and  $b'$ . Triangles  $Opb$  and  $Op'b'$  are similar because their sides are respectively parallel. Then the corresponding sides are proportional. Specifically,

$$\frac{pb}{p'b'} = \frac{Op}{Op'}$$

But  $pb = r$ ,  $p'b' = r'$ ,  $Op = f$ ,  $Op' = mf$ . Then

$$\frac{r}{r'} = \frac{f}{mf} = \frac{1}{m}$$

$$r = \frac{r'}{m}$$

$$r' = rm$$

Substituting  $rm$  for  $r'$  in equation 3224A,

$$d_s = rm - r = r(m - 1)$$

The second part of equation 3224B is obtained by substituting  $(r' - m)$  for  $r$

*Example* The scale of a photograph is 1/19,750. What is the displacement due to the scale alone of an image 250 mm from the center relative to a 1/20,000-scale map?

Solution  $m = S - S' = (1/19,750) - (1/20,000) = 1.0127$   
 $d_s = r(m - 1) = 250(1.0127 - 1) = 3.18 \text{ mm}$

### 323 RELIEF DISPLACEMENT

The discussion of relief displacement considers the effect that the varying elevation of the terrain has on the relative positions of images on a photograph. The effect is due entirely to the fact that a photograph is a perspective projection. The corresponding orthogonal or map position for an image is cited for comparison. Relief displacement is evident on photographs in the form of a "lean" or "overhang" of tall objects, such as buildings, tall stacks, and mountains.

#### 3231 Direction of Relief Displacement

An image is displaced due to the elevation of the object along a line that passes through the principal point, if the photograph is not tilted. The angular arrangement of images relative to the center of the photograph is not disturbed in any manner by the elevations of the objects if there is no tilt.

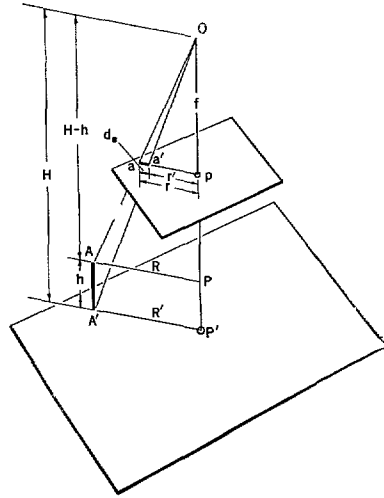

FIGURE 3.6—The magnitude and direction of relief displacement

In figure 3.6 is shown a vertical object  $AA'$  whose top has an elevation  $h$ , and the image  $aa'$  on a photograph of focal length  $f$  taken from the perspective center  $O$  at a flying height  $H$  above the datum plane. The base  $A'$  of the elevated object lies in the datum plane,  $p$  is the principal point and  $OpPP'$  is the vertical lens axis. The point  $a'$  is the image of the base of the object, and  $a$  is the displaced image of the top of the object. It is to be shown that the displaced image  $a$  lies on the radial line  $pa'$  that passes through the principal point and the image of the base.

The plane  $OP'A'A$  is a vertical plane because it contains at least the one vertical line  $OP'$ . It also contains the object line  $AA'$ . The points  $a$ ,  $a'$ , and  $p$  each lie in the vertical plane because they lie on the straight-line image rays  $OA$ ,  $OA'$ ,  $OP'$ , respectively. The points  $a$ ,  $a'$ , and  $p$  also lie in the plane of the photograph by definition. Hence, the line  $aa'p$  must be a straight line because it is the line of intersection of two planes. Therefore,  $a$  lies on the line  $pa'$  and  $a$  is said to be displaced radially from  $p$  and  $a'$  due to the elevation  $h$  of the object. It can be considered that  $a'$  is the proper map position for the feature. In practice the elevated object might be a hilltop whose base position is not indicated but is obtained by the radial line method (see 325).

3232 Amount of Relief Displacement

The amount of displacement  $d_e$  of an image due to the elevation of the object is defined as (see fig. 3.6)

$$d_e = r - r'$$

which can also be expressed algebraically as

$$d_e = \frac{r h}{H}, \tag{3232A}$$

$$d_e = \frac{r' h}{H - h}. \tag{3232B}$$

From the similar triangles  $Opa$  and  $OPA$ ,

$$\frac{ap}{Op} = \frac{AP}{OP}$$

or

$$\frac{r}{f} = \frac{R}{H-h}$$

$$r(H-h) = Rf$$

where  $r$ ,  $f$ ,  $R$ , and  $H$  are as denoted in the figure. Similarly, from the similar triangles  $Opa'$  and  $OP'A'$ ,

$$\frac{r'}{f} = \frac{R}{H}$$

$$r'H = Rf$$

Equating the two equal expressions,

$$r(H-h) = r'H$$

$$r = \frac{r'H}{H-h}$$

$$r' = \frac{r(H-h)}{H}$$

Substituting for  $r'$  in the definition,

$$d_e = r \left[ \frac{H-h}{H} \right] = r \left[ 1 - \frac{H-h}{H} \right]$$

$$d_e = r \left[ \frac{H - (H-h)}{H} \right] = \frac{rh}{H} \quad (3232A)$$

Similarly, equation 3232B is obtained by substituting for  $r$  in the definition

Equation 3232A is sometimes solved for  $h$  to give an equation for the determination of elevations

$$h = \frac{d_e H}{r} \quad (3232C)$$

Equation 3232A is used in planning photogrammetric mapping to determine the amount of displacement to be expected with regard to its effect upon map compilation. Equation 3232B is used in the rectification of photographs for displacing a map position of a feature so that the displaced position is the correct location of the image of the elevated object on a photograph of specified flying height and of zero tilt.

Equation 3232B is also used in flight planning to determine the percentage of overlap needed in photographs over rugged terrain. Equation 3232A is often used as an approximation for the latter application because it is easier to compute. Extensive graphs have been compiled for use in repeated solutions of equation 3232B (fig 3 50). Equation 3232C is used for rough determinations of elevations where a map, such as a radial plot, is available from which to determine the element  $r'$ , from which  $d_e$  may be found by applying the definition.

*Example 1* How much will an 800-foot hilltop be displaced if it appears 5 inches from the principal point and the flying height is 14,000 feet?

Solution

$$d_o = \frac{r'h}{H} = 5 \times 800 \div 14,000 = 0.286 \text{ inches}$$

If  $h$  is in the same unit as  $H$ , the unit of  $d_o$  will be the same as that of  $r$ , but the two sets of units need not be the same

*Example 2* In a radial plot a feature is 360 mm from the principal point. The elevation of the object is 270 feet. How much and in what direction should the position of the feature be moved on a rectification templet if the flying height is 12,000 feet?

Solution

$$d_o = \frac{r'h}{H-h} = 360 \times 270 \div (12,000 - 270)$$

$$d_o = 8.29 \text{ mm}$$

The position of the feature should be moved 8.29 mm outward along the line that passes through the feature and the principal point

### 324 THE THEORY OF FLIGHT PLANNING

The planning and execution of aerial photography are discussed in chapter 2, whereas some of the mathematical or theoretical problems underlying the practice—particularly those problems that are readily explained by the foregoing principles of the vertical photograph—are included under this subject. This subject discusses the choice of cameras, as regards angular coverage and focal length, the selection of flight heights, and the determination of such items as the overlap of photographs, the time interval between exposures, and the distance between flight strips.

#### 3241 Some Factors Affecting the Selection of Flying Height

The cost of photogrammetric mapping is roughly proportional to the number of photographs used and increases as the number of photographs required to cover an area increases. Consequently, aerial photographs are usually taken at as high an altitude as practicable and consistent with the particular map specifications.

A number of different cameras of different focal lengths and angular fields have been developed to meet specific mapping requirements (see chapter 2). Nevertheless, the selection of a value for the flying height is always a compromise of a large number of factors. Some of these factors are of a theoretical nature and are discussed here, namely, (a) the scale of the photograph with reference to the accuracy requirements of the map, (b) the limit of enlargement with regard to image definition, and (c) the effect of the angular field of view of the lens and camera unit.

The relation of scale, focal length, and flying height was shown in 3222 to be

$$S = \frac{f}{H - h} \quad (3222C)$$

where  $S$  is the value of the scale of a photograph usually expressed as a representative fraction having one for its numerator,  $H$  is the flying height above sea level,  $f$  is the focal length of the aerial camera, and  $h$  is the average elevation of the terrain above sea level. It is evident from the equation that a larger scale of aerial photography can be obtained by (a) selecting a camera of a long focal length, (b) selecting a low flying height, (c) enlarging the photographs in the laboratory, which is theoretically equivalent to selecting a camera of longer focal length (see 3223), or (d) using a combination of some, or all, of the three possibilities.

Although high altitude photographs are desirable for economy, the maximum flying height is limited by several factors, an important one of these is the quality of image definition required on the photographs. Mapping standards, including accuracy specifications (see 12), specify the contents or the details to be shown on a map at a given scale and the accuracy with which those details must be located. The images of ground details to be mapped must be clearly visible on the photographs and at the same time the photographs must possess such constant geometric properties that the positions of the features can be located with the required accuracy.

The clarity of images of features on aerial photographs is largely a function of the scale of the photographs. With a camera of a given focal length, there is a maximum flying height beyond which the images of map features are no longer clearly visible to the unaided eye. The maximum practical flying height is obviously different for maps of different scales because the choice of the types of map features to be shown is governed to a large degree by the scale of the final map. A photographic negative and the contact print are usually of such quality that small images are present that cannot be seen with the unaided eye, but which are visible on a photographic enlargement. Thus it is sometimes permissible to choose a comparatively great flying height and use ratio prints (enlargements) instead of contact prints in the map compilation. The accepted limit of enlargement for single-lens photographs of the Coast and Geodetic Survey is about 3 diameters, but the enlargement is often limited to 2 diameters and is rarely as great as 4 diameters. At about 3 diameters enlargement, the loss in the sharpness of images due to the graininess of the emulsion and various other reasons is noticeable to the unaided eye, and greater enlargement is of little or no benefit in graphic compilation.

In some instances a mapping project is photographed twice—once at a low altitude for the compilation of details and again at a high altitude for the purpose of establishing photogrammetric control points between widely spaced ground control stations to be used as control for the lower altitude photographs. A sufficient number of clear images can generally be identified on the high altitude, small-scale photographs to provide pass points for the control breakdown by means of a radial plot or stereoscopic plotting instrument, points located by the small-scale photographs are used for a further control breakdown and for the compilation of detail. By this solution it is sometimes possible to compile a map with a smaller number of ground control stations without sacrificing image definition, but the solution is rather limited in its practicable application.

The angular field of view of an aerial camera is another variable that should be considered in planning aerial photography. Inasmuch as flying height and focal length are quite rigidly fixed by the specifications of the scale of photography, the angular field of view is yet another means by which it is possible to reduce the number of photographs. An increase in the angular field of view in the design of an aerial camera causes a corresponding increase in the area of terrain shown in each photograph, and thus decreases correspondingly the number of photographs required to cover a given area.

At the present time, lenses for aerial photography for accurate mapping are limited to an angular field of view of slightly more than 90 degrees. In the use of the 6-inch wide-angle lens with a 9- by 9-inch negative, the total area covered is somewhat reduced because the entire circular field is not included on the negative, but the *effective* area, so far as the number of required photographs is concerned, is *not* reduced because the effective shape of the photograph must be considered as rectangular (a square is the largest rectangle that can be inscribed in a circle) and the corners of the 9- by 9-inch mask include the outer rim of the possible circular photograph. Wide-angle lenses having an



angular field of 90 degrees are also made in focal lengths of 5.2 and 4 inches. Where these shorter focal length lenses are used with standard 9-inch film, most or all of the field of view of the lens is included on the film. This fact is sometimes considered as an advantage for stereoscopic contouring because the flight lines can be planned so as to give a slightly longer base length by considering the area as rectangular with the longer dimension in the direction of flight which, of course, slightly increases the required number of photographs. However, for many purposes, the 6-inch focal length is preferred and it is generally believed that only a small amount of the useful field of view is lost due to the 9-inch film size because image definition on photographs taken with wide-angle lenses is usually quite poor near the outer edges of the field.

Research is constantly endeavoring to increase the angular coverage of lenses for aerial photography. One improvement, which shows promise of completion, is the development of a wider-angle lens (about 120°) that compresses the image area by optical distortion onto the standard 9-inch film. The photograph will then be restored to an undistorted condition by laboratory projection through a special lens of opposite distortion characteristics.

The Coast and Geodetic Survey has developed the nine-lens camera (see chapter 2) to solve the problem of obtaining a large angular field of view. The resulting composite photograph is a 35.4-inch square, and its dimensions are nearly four times as large as a 9-by-9-inch photograph, thus each nine-lens photograph covers about the same area as 16 single-lens photographs without overlap at the *same scale*. The field of view subtended by opposite corners of the photograph is more than 140 degrees. The nine-lens camera was designed for relatively large-scale mapping—that is, 1:10,000 to 1:30,000. Consequently, the focal length is approximately 8¼ inches and the film is 23 by 23 inches. If the *same area* were to be covered with a 6-inch camera using 9-by-9-inch film, it would be necessary to fly very much higher and a smaller scale would be obtained. For example, if the nine-lens camera is flown at 14,000 feet, an area about 11 miles square can be photographed at 1:20,000 scale. To cover the same area the 6-inch camera would have to be flown at an altitude of 40,000 feet (which is impractical for domestic mapping at the present time) and a scale of 1:80,000 would be obtained which theoretically might be enlarged 4 diameters to be equal to the scale of the corresponding nine-lens photograph, but these conditions of flying height and enlargement are generally not satisfactory for large-scale mapping.

Two other facts about wide-angle photography are. (a) it is possible to encounter large ground radial distances, such as  $R$  in **3232**, and (b) photographs can be taken at greater ground intervals, such as base length  $B$  in **3261** for each pair of photographs. These two features are discussed next.

Considerable difficulty is encountered in the graphic compilation of planimetric maps where there are large relief displacements. Consequently, aerial photography for use in planimetric mapping is often planned so that the relief displacements will be as small as practicable. If control is not a major consideration, relief displacement can be reduced by using a camera with a comparatively narrow angular field and by selecting a comparatively long focal length, thus reducing the area covered by each photograph at a given flight altitude. Furthermore, once the angular coverage and focal length are determined, relief displacements can be further decreased by increasing the flight altitude so far as this is consistent with the map to be compiled. Actually, the decision is usually a compromise of factors considered in the following paragraphs.

It was shown in **3232** that

$$d_e = \frac{rh}{H} \quad (3232.1)$$

where  $d_e$  is relief displacement,  $r$  is the radial distance from the center of the photograph to the image of the top of an object, and  $H$  is the flying height of the aircraft. It was also pointed out in the derivation that

$$\frac{r}{R} = \frac{f}{H-h} \text{ or } r = \frac{Rf}{H-h}$$

where  $R$  is the horizontal ground distance from the point vertically beneath the camera to the object, and  $f$  is the focal length of the aerial camera. It was shown in 3223 that a ratio print of magnification  $m$  and focal length  $f$  is exactly equivalent to a contact print made with a camera of focal length  $mf$  from the same point in space. The following relation is obtained by substituting these quantities in equation 3232A

$$d_e = \frac{Rmfh}{H(H-h)}$$

Inasmuch as  $h$  is usually very small relative to  $H$ ,  $h$  can be neglected in the denominator without materially affecting the value of  $d_e$ , and a more simplified expression is obtained for this analysis

$$d_e = \frac{Rmfh}{H^2}. \quad (3241A)$$

In view of the fact that the product  $mf$  is the equivalent focal length of a ratio print, then  $\frac{mf}{H}$  is the scale  $S$  of the ratio print and

$$d_e = \frac{RhS}{H} \quad (3241B)$$

A study of equations 3241A and 3241B indicates that the amount of image displacement  $d_e$  on any photograph ( $m = 1$  for a contact print), is increased if  $R$ ,  $m$ ,  $f$ ,  $h$ , or  $S$  is increased, and that the displacement is decreased if  $H$  is increased. Thus the flight planner can alter the values of any of these terms except  $h$  within certain practical limits to satisfy best a particular mapping program. Obviously, the most effective means for reducing relief displacement is to increase the value of  $H$  because that term is squared. The maximum possible value of  $R$  is not only affected by  $f$  and  $H$ , but also by the angular coverage of the camera. Values of  $m$ ,  $f$ , and  $H$  are chosen so as to yield the desired scale of the planimetric map for graphic compilation. Inasmuch as  $m$  is a constant factor limited in practice to about three, then only  $f$  and  $H$  can be changed, but they must be changed in the same ratio to maintain a given value of  $S$ . For example, if it is decided to double a given flying height, then the product of magnification and focal length ( $mf$ ) must also be doubled to obtain the scale value. The present values of  $m$  and  $f$  are, of course, limited to the focal lengths of the available aerial cameras and the acceptable ratios of enlargement.

Large relief displacements are necessary for compiling topographic maps from aerial photographs, in contrast to planimetric maps where small displacements are preferred. A study of equation 3241A indicates that the most effective method for increasing the displacement is to decrease the flying height. Consequently the prescribed flying height for topographic mapping is usually stated as a numerical factor times the required contour interval. The factor varies from 200, where comparatively crude methods are to be used, to 2,000, where the most precise stereoscopic plotting instruments are to be used. However, decreasing flying height increases the number of photographs, a fact which is doubly important economically in topographic mapping because an object of known elevation is required in each of the four corners of each overlap area.

A difference in elevation, such as 20 feet, corresponds to a very small difference (parallax) in the relative positions of pairs of corresponding images on two overlapping photographs. Consequently, any effort that results in a greater parallax difference also improves the accuracy in drawing contour lines stereoscopically. It already has been pointed out that radial distances and base lengths are effectively increased by wide-angle cameras, and it is shown in 3264 that parallax difference is directly related to relief displacement. Thus, parallax differences are increased as the angular coverage of the camera is increased and as the flying height is decreased. Thus, for stereoscopic contouring, an increase in angular coverage permits an increase in the flying height with a consequent decrease in the number of photographs and a decrease in the cost of mapping—provided image definition is maintained.

### 3242 *Photograph Spacing and Related Topics*

It is presumed that the three elements—flying height, focal length, and scale—have all been determined and the formulas derived herein are based on the known value of the scale of the aerial negative. Obviously, the values selected for any two of the elements fix the value of the third element by virtue of equation 3222C,  $S = \frac{f}{H - h}$ .

The length  $u$  and the width  $w$  (see fig. 37) of the negative of the aerial camera must be known for the study, where  $u$  is considered as the dimension of the photograph measured parallel to the direction of flight. (The word *format* has been frequently used to mean the shape and size of the negative of a particular photogrammetric camera.) Most of the newer aerial cameras produce square photographs, whence  $u$  and  $w$  are equal, and perhaps the two terms could be represented by a single letter. However, there are exceptions, and here the two terms are considered as being different so as to derive expressions that are applicable to all types of cameras. Also, the value of  $u$  is not necessarily larger than that of  $w$ . For example, the 7-inch dimension of the former 7- by 9-inch photograph was customarily oriented parallel to the line of flight for planimetric mapping, but the 9-inch dimension was kept parallel to the flight line for topographic mapping because greater parallax differences were thus created which increased the accuracy with which heights could be determined. The symbols  $U$  and  $W$  are used here to represent the ground distances that correspond to  $u$  and  $w$  respectively.

Aerial photographs for mapping purposes are taken so that there is ample overlap in both directions. The overlap is required to afford stereoscopic vision and to furnish common images which are used to "tie" the photographs together to form a continuous accurate map. The overlap in the direction of flight is called *forward lap* and that perpendicular to the line of flight is called *side lap*. The overlap in both directions is usually stated in terms of percentage. Thus, a forward lap of 60 percent indicates that each photograph overlaps the next one in the same flight line a linear amount equal to 60 percent of its  $u$  dimension. The letter  $e$  (for end) is used here to designate the percentage or fraction of forward lap, and  $s$  is used for the side lap. Thus, if the side lap is 20 percent, then  $s = 20\% = 0.2$ .

A forward lap of 60 percent is almost always used. There are a few exceptions, especially in the use of the nine-lens camera in extremely rugged terrain where a value of 80 percent or greater is sometimes selected to minimize relief displacements and hidden areas. It is quite important that the forward lap for topographic mapping with single-lens photographs be maintained within 55 to 65 percent because as long a base length as prac-

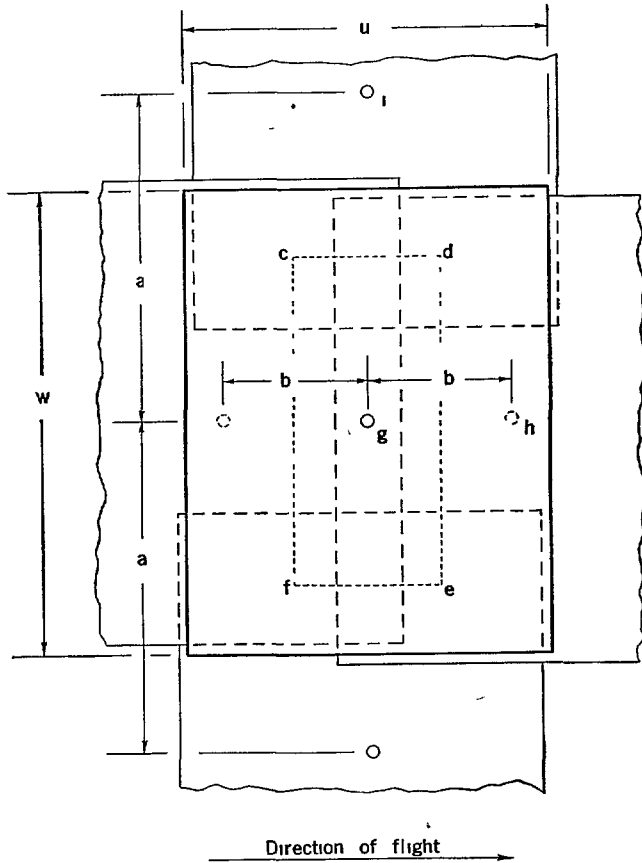

FIGURE 37—The usual overlapping arrangement of aerial photographs

ticable is required, and a still lesser forward lap (51 to 54 percent) necessitates the use of the edge of the photograph where the definition is not so good. The values for the side lap vary greatly due to special considerations, but the Coast and Geodetic Survey ordinarily uses 30 per cent for single-lens photographs and 60 percent for nine-lens photographs.

*Base length* is the distance between the centers of two photographs in line of flight. The symbol  $B$  is used to represent the ground dimension, and  $b$  to represent the corresponding distance on the photographs. The distance  $b$  is also approximately equal to the distance between the principal point of a photograph and one of the conjugate principal points in line of flight, where the latter point is the apparent position on a given photograph of the image of the principal point of an overlapping photograph. *Base width* is the perpendicular distance between two lines of flight, and the letters  $A$  and  $a$  are used here to represent the distances on the ground and on the photograph, respectively. It is quite obvious from figure 37 that

$$b = u(1 - e) \tag{3242A}$$

$$a = w(1 - s) \tag{3242B}$$

Then from equation 3221A,

$$B = u(1 - e) \frac{1}{S} \tag{3242C}$$

$$A = w(1 - s) \frac{1}{S} \tag{3242D}$$

where  $\frac{1}{S}$  is the denominator of the known representative scale fraction for the aerial negative and contact print. For example, if the scale  $S$  is 1/20,000, then  $\frac{1}{S}$  is the whole number 20,000. It is desirable to express  $B$  and  $A$  in units of statute miles, whereas it is convenient to measure  $u$  and  $w$  either in inches or millimeters. Thus, equations 3242C and 3242D are rewritten so as to incorporate the change in units of measurement.

$$B \text{ (in miles)} = \frac{(u \text{ in inches}) (1 - e) \frac{1}{S}}{63,360} \quad (3242E)$$

$$A \text{ (in miles)} = \frac{(w \text{ in inches}) (1 - s) \frac{1}{S}}{63,360} \quad (3242F)$$

$$B \text{ (in miles)} = \frac{(u \text{ in mm}) (1 - e) \frac{1}{S}}{1,609,350} \quad (3242G)$$

$$A \text{ (in miles)} = \frac{(w \text{ in mm}) (1 - s) \frac{1}{S}}{1,609,350} \quad (3242H)$$

*Example 1* Determine the ground distances between exposures and between flight strips for 9- by 9-inch photographs at a scale of 1/24,000 where the forward lap is 60 percent and the side lap is 30 percent.

*Solution* Applying equations 3242E and 3242F,

$$B = \frac{9 \times (1 - 0.6) \times 24,000}{63,360} = 1.36 \text{ miles between exposures}$$

$$A = \frac{9 \times (1 - 0.3) \times 24,000}{63,360} = 2.39 \text{ miles between strips}$$

The values for  $U$ ,  $W$ ,  $B$ , and  $A$  are used in planning flights for aerial photography and for laying out the flight lines on the best map available for the information of the aerial navigator and photographer. These dimensions are frequently used for making a small paper or celluloid templet corresponding to the size and shape of the photograph at the scale of the flight map. The dimensions  $u_m$ ,  $w_m$ ,  $b_m$ , and  $a_m$  at the scale of the flight map can be determined in either of two ways. (a) If there is a graphic scale on the margin of the flight map, the map dimensions of the templet can be scaled from the graphic scale with a pair of dividers from the known values of  $U$ ,  $W$ ,  $B$ , and  $A$  in miles, or (b) The following equation can be used for computing the flight map dimensions of the templet from the known values  $u$ ,  $w$ ,  $b$ , and  $a$ .

$$w_m = \frac{w \times \frac{1}{S_p}}{\frac{1}{S_m}} \quad (3242I)$$

in which  $S_p$  is the scale of the aerial negative and  $S_m$  is the scale of the flight map. The other dimensions are obtained by substituting the corresponding values in place of  $w$  in the same equation. The equation is the inverse of that used in *example 2* in 3222.

*Example 2* Determine the distances between exposures and between flight strips and the dimensions of the area covered by a single photograph for a flight map of 1 40,000 scale for the conditions of *example 1*

Solution By equations 3242*A* and 3242*B*,

$$b = 9 \times (1 - 0.6) = 3.6 \text{ inches}$$

$$a = 9 \times (1 - 0.3) = 6.3 \text{ inches}$$

Then applying equation 3242*I*,

$$b_m = \frac{3.6 \times 24,000}{40,000} = 2.16 \text{ inches}$$

$$a_m = \frac{6.3 \times 24,000}{40,000} = 3.78 \text{ inches}$$

Inasmuch as  $u$  and  $w$  are each 9 inches,

$$u_m = w_m = \frac{9 \times 24,000}{40,000} = 5.4 \text{ inches}$$

The theoretical number  $N$  of photographs required to cover a given project area is given by the expression

$$N = \frac{\text{Area of project}}{AB} \quad (3242J)$$

The expression is of analytical importance although it may be of little practical value. Consider the area  $cdef$  in figure 37 where the line  $de$  is halfway between the photograph centers  $g$  and  $h$ , and the line  $cd$  is halfway between the centers  $g$  and  $i$ , etc. This area can be considered as the net area of the one photograph, inasmuch as the sum of the net areas of all the photographs would be equal to the total area, disregarding the irregularities at the edges of the area. It can be shown that  $cd$  is equal to  $b$  and  $de$  is equal to  $a$ . Thence,  $AB$  is the net ground area shown by a single photograph, which is related to the values  $u$ ,  $w$ ,  $e$ ,  $s$ ,  $S$ ,  $a$ , and  $b$  in accordance with equations 3242*A*, *B*, *C*, and *D*.

It is to be noted in equation 3242*J* that the number of photographs can be reduced by an increase in the value of  $AB$ , which, in turn, can be increased either by increasing  $u$  and  $w$  or by decreasing  $S$  (equations 3242*C*, 3242*D*, and 3222*B*). The values of  $u$  and  $w$  can be increased with the use of a wide-angle lens where the focal length remains fixed.

The value of  $S$  can be decreased by decreasing the value of  $f$  in  $S = \frac{f}{H}$ , or by increasing the value of  $H$ . In practice, a combination of both methods is used. A wide-angle lens is used along with a shorter focal length so that the photograph is of the same dimensions as before to enable the use of a standard film width, but the photograph is of smaller scale to include greater ground area.

The time interval between exposures is obviously related to the ground base length  $B$  and the velocity  $V$  of the aircraft. This interval is required to determine whether or not enough time elapses between exposures for the camera to rewind and be ready for the next exposure. The working value of the interval is affected greatly by winds and is determined by the photographer during flight for each strip by using the viewfinder and a stop watch. A practical minimum interval is about 20 seconds, and a good working minimum is 30 seconds. The theoretical interval  $\tau$  can be computed for planning purposes from

$$\tau \text{ (in seconds)} = \frac{B \text{ (in miles)} \times 3600}{V \text{ (in statute miles per hour)}} \quad (3242K)$$

Aircraft velocities are usually stated in miles per hour, but occasionally they are given in knots, for which the constant 3126, instead of 3600, must be used in equation 3242*K*.

*Example 3* Determine the interval for *example 1* if the aircraft speed is 120 miles per hour

Solution Applying equation 3242K,

$$i = \frac{1.36 \times 3600}{120} = 40.8 \text{ seconds}$$

The distance through which an image point moves while the shutter of the aerial camera is open for exposure is sometimes required for flight planning in order to determine whether or not the movement is sufficiently great to damage image definition. Thus, it might be found necessary to specify a maximum exposure that should not be exceeded in taking the photographs. From the facts that the resolution of the film and lens is probably no greater than 50 lines per millimeter, and that the value is usually 20 to 25 lines per millimeter in practice, it is reasonable that a movement of 0.02 mm has little or no effect on image definition, and that twice as much, or 0.04 mm, might be somewhat objectionable for photographs that are to be enlarged.

Image definition is generally satisfactory if it is at least 5 lines per millimeter for the scale at which the photograph is to be viewed during the map compilation procedure. Thus, if a photograph is to be used only as a contact print without optical magnification, then the minimum resolution should be 5 lines per millimeter, if the photograph is to be enlarged 3 diameters for use in radial plotting, the resolution on the negative should be 15 lines per millimeter, and if the photograph is to be viewed with the stereoplanigraph at a magnification of 5 diameters, then the resolution on the negative should be 25 lines per millimeter. This analysis is not affected by the use of a magnifier for identification of control and pass points in the preparation of photographs for radial plotting because the final plotting accuracy is no greater than the graphic construction of the radial lines, which is done with the naked eye, and which is subject to an error of at least  $\pm 0.1$  mm.

Consequently, the movement of the image during exposure should not be greater than that which will result in a value for image resolution greater than 0.2 mm at the scale at which the photograph is to be viewed.

The magnitude of the image movement  $j$  in millimeters for a basic exposure of  $\frac{1}{100}$  of a second is given by

$$j = 4.47VS \quad (3242L)$$

where  $V$  is the velocity of the aircraft in miles per hour and  $S$  is the scale of the aerial camera negative. The value for any other exposure value can be obtained by multiplying by the proper factor.

*Example 4* Determine the image movement for the conditions of *examples 1* and *3* for exposures of  $\frac{1}{50}$ ,  $\frac{1}{100}$ , and  $\frac{1}{200}$  of a second.

Solution

$$j \text{ for } \frac{1}{100} \text{ second} = 4.47 \times 120 \times \frac{1}{24,000} = 0.022 \text{ mm}$$

$$j \text{ for } \frac{1}{50} \text{ second} = 2 \times 0.022 = 0.044 \text{ mm}$$

$$j \text{ for } \frac{1}{200} \text{ second} = 0.5 \times 0.022 = 0.011 \text{ mm}$$

Special problems are sometimes encountered in flight planning relative to the amount of side lap and flight spacing for areas where there is rugged terrain. Images of very high objects located midway between two flight strips sometimes do not fall within the limits

of the photographs of either flight because of relief displacement where the overlap and spacing are planned on the basis of the elevation of the lower terrain of the area. It is usually satisfactory if the effective overlap for high objects is as low as 5 percent where a greater value is specified for the side lap in lower terrain. Formulas are now derived for determining (1) the distance between flight strips that will assure a given minimum side lap for specific elevations and (2) the highest elevation for which there will be assured a given minimum side lap for a given set of flight conditions.

The term  $\frac{f}{H-h}$  is substituted for  $S$  (equation 3222C) in equation 3242D.

$$A = \frac{w(1-s)(H-h)}{f} \quad (3242M)$$

Here  $A$  is the distance between flight strips,  $s$  is the desired minimum side lap,  $H$  is the flying height above sea level that has already been determined as preferable for the photography,  $h$  is the elevation of the highest terrain in the area, and  $f$  is the focal length of the camera. The solution for the element  $h$  yields

$$h = H - \frac{Af}{w(1-s)} \quad (3242N)$$

*Example 5* What is the highest ground elevation in *example 1* at which there will be a side lap of 5 percent if the camera focal length is 6 inches?

*Solution* *Example 1* was computed as though the terrain elevation were at sea level, whence from equation 3222C,  $H$  is 12,000 feet. Then, applying equation 3242N,

$$h = 12,000 - \frac{2.39 \times 5280 \times 6}{9(1-0.05)} = 3144 \text{ feet}$$

*Example 6* What should be the ground flight spacing that will assure a 5 percent side lap in *example 1* for terrain 5,000 feet in elevation where a 6-inch camera is used?

*Solution* As in *example 5*, the flying height is 12,000 feet, and from equation 3242M,

$$A = \frac{9(1-0.05)(12,000-5,000)}{6 \times 5280} = 1.89 \text{ miles}$$

Relief displacement of images of high objects in the line of flight is usually not objectionable because the forward lap is so large that if the flight is planned so as to provide sufficient side lap, then the forward lap will be adequate.

### 325 THEORY OF RADIAL PLOTTING

The theory of radial plotting is based on well-known principles of mathematics and surveying, as well as on certain geometrical characteristics of aerial photographs. The theoretical fundamentals are introduced here, but no attempt is made to outline the practical procedures. Specific and detailed instructions for radial plotting are in chapter 4.

#### 3251 The Radial Assumption

It is assumed in radial plotting that image displacements due to all sources, such as relief, scale, tilt, lens, film, and paper, occur in radial directions from a specified radial center so that the angular arrangement of the images on a photograph as measured at this radial center are correct. An angle at the principal point subtended by any two images on a *truly vertical* photograph is equal to the horizontal angle at the ground point  $P$  (see fig. 33) subtended by the corresponding two objects. This fact is quite obvious because (1) a hori-



zontal angle is defined as the dihedral angle between two vertical planes, (2) the ground principal point  $P$  is vertically beneath the perspective center  $O$  and the photograph principal point  $p$ , if the photograph is not tilted, and (3) equal horizontal angles are subtended by any two objects at *any* point on the vertical line  $OP$ . A dihedral angle is the opening between two intersecting planes measured in a third plane that is perpendicular to the line of intersection of the first two planes. Dihedral angles are measured in ground surveying with a transit or a theodolite inasmuch as the horizontal plane of the instrument is leveled according to the indication of level bubbles, and the cross hair of the telescope is free to sweep in a truly vertical plane. Thus a horizontal angle measured at  $P$  on the ground between two objects with a transit is a dihedral angle between the two vertical planes that contain the two objects and that intersect in a vertical line through  $P$ . Moreover, the angle at  $p$  on a truly vertical photograph is also the dihedral angle between the same two vertical planes because the plane of the photograph is truly horizontal.

The radial assumption is sometimes referred to as the principal point assumption where vertical photographs are implied because image displacements are toward or away from the principal point. It was noted in **3224** and **3231** that differences in the scales of photographs and the elevations of objects do not affect the angular arrangements of images about the principal point of a truly vertical photograph. It might also have been pointed out in **317** that lens distortion does not seriously affect the angular arrangement of images about the principal point so far as radial plotting is concerned. The foregoing principles are facts rather than assumptions.

The only image displacements that do not comply with the foregoing principles are those displacements that are due to tilt and to the instability of photographic materials. In terms of the explanation at the end of the previous paragraph, if a photograph is tilted, the photograph perpendicular  $pO$  (see fig 33) is not a vertical line, and angles measured at  $p$  between pairs of images are not dihedral angles because the plane of the photograph is not horizontal. Hence, the angles measured at  $p$  on a tilted photograph are not equal to the corresponding angles on the ground. However, most vertical photographs are tilted so slightly that the radial assumption can generally be assumed to be valid for practical purposes. This is discussed further in **34**, and practical methods are also discussed in chapter 4 for minimizing the effects of tilt. Paper and film shrinkage are controlled by the use of proper materials and also by special corrections. (See chapter 4.)

Horizontal angles can also be obtained from oblique and horizontal photographs and utilized as in radial plotting, but such angles are obtained indirectly by certain graphic constructions or by special instruments. (See **37**.)

### 3252 *Graphic Resection*

Graphic resection is the solution by graphic methods of the three-point problem in surveying by which is determined the position of the point of observation by means of horizontal angles observed between three or more points of known position. It can be shown that each problem ordinarily has a unique solution. The solution in plane surveying is often performed by computation. In hydrography the problem is solved by plotting the position with a three-arm protractor on which are set the horizontal angles measured by sextant. (See Special Publication No 143, Hydrographic Manual, subject **333**.)

Graphic resection can be performed (see fig 38) by (a) plotting the positions of three control stations on a map projection, (b) constructing the observed angles on a transparent sheet (templet) showing merely the three lines of indefinite length radiating from a common

center, and (c) superposing the templet on the map projection and adjusting the templet so that each radial line passes through its respective control point. The adjusted position not only defines the position of the observer on the map projection but also defines the orientation of the templet.

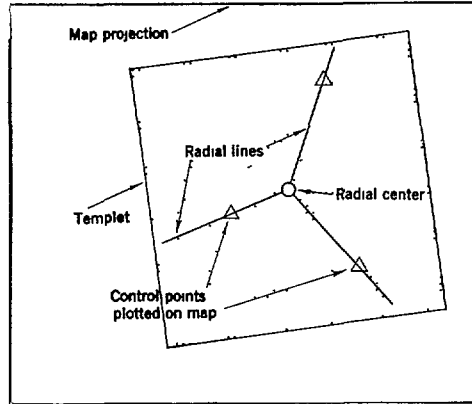

FIGURE 3 8 —The principle of graphic resection as used in radial plotting

*Exercise* The photogrammetrist should satisfy himself that there is only one solution for a given three-point problem—that there is only one position and orientation of the templet such that all rays pass exactly through the respective plotted positions. This can be done by placing three points anywhere (except the indeterminate arrangement, which is explained later) on a sheet of paper, constructing a transparent templet of any three radiating lines having no relation to the three points, superposing the templet on the three points, adjusting the position of the templet to fit the three points, marking the center position, and then removing and readjusting the templet to prove that two independently determined solutions result in the same location for the center of the templet.

Graphic resection is obviously applicable to photogrammetry. By this method the position of the principal point and the geographic orientation of a vertical aerial photograph can be determined from the horizontal angles subtended by the images of three points of known position. Moreover, the templet can be traced directly from the photograph without actually measuring the angles.

Resection is also called a “three-point fix” because the point of observation is “fixed” by the angles subtended by the three points. The strength of a fix refers to the relative change in the determined position that can occur before the solution appears to be in error. The strength of a fix is affected by the relative arrangement of the control points. For example, if the principal point of a radial templet is at the center of the equilateral triangle formed by the control points, then the templet cannot be moved in any direction without causing at least one of the rays to miss its control point. This is the strongest fix. But where all three control points are on one side of the templet, it is sometimes possible to shift and rotate the templet an appreciable amount before any one of the rays misses its control point.

Resection is indeterminate where the three control points and point of observation (the center of the templet in radial plotting) all lie on the circumference of the same circle. This feature is an application of the theorem in geometry that states that the magnitude of the angle subtended by a chord of a circle at some point of the circumference is invariant with respect to the location of the point on the circle. Thus, where the positions of the three control points and the position of the principal point of a radial templet lie on a

common circle, then the templet can be fitted to the three points in innumerable positions because the three chords determined by the three points subtend equal angles at the templet center regardless of where the radial center is placed on the circle of the three points. Moreover, where the principal point and the three control points lie *approximately* on the same circle, there are often a number of positions for the templet center that seem to give equally satisfactory solutions to the resection problem. In radial plotting, the indeterminate case and the case of a weak fix are usually solved by the use of a fourth control point, which obviously must not lie on or near the circle of the other points. (See also 425.)

The problem of graphic resection is based on a minimum of three control points but there is theoretically no limit to the maximum number of points that can be used. The use of more than three points provides a check on the solution and generally improves the strength and accuracy of graphic resection. In radial plotting, there are usually more than three points, although some or all of them might have been determined previously by graphic intersection (see 3253) rather than by ground surveying.

### 3253 Graphic Intersection

Graphic intersection is the solution by graphic methods of the problem in mathematics and surveying that determines the position of a point by means of directions measured at two points of known position to the unknown point. It is equivalent to the trigonometric solution of any triangle where two angles and the included side are given. The resulting position of the intersected point can be obtained by graphic construction as well as by computation.

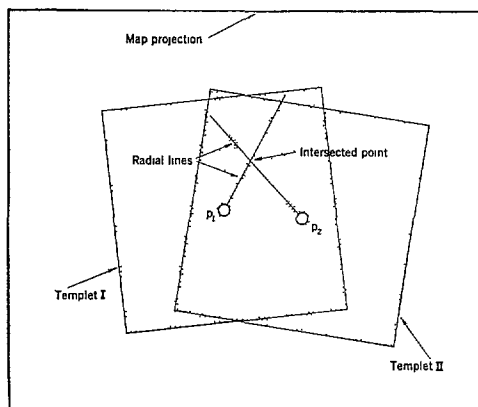

FIGURE 39—The principle of graphic intersection as used in radial plotting

In radial plotting, the two points of known position ( $p_1$  and  $p_2$  in figure 39) are the radial centers of two templates (I and II) that have been fixed in both position and orientation by prior graphic resection. The two angles are in the form of two radial lines of indefinite length, one traced on each templet through the corresponding image on each of the two photographs. The intersection of the two radial lines is the position of the image on the map sheet and the intersected point is properly related to the plotted control points that previously determined the problems of resection. All lines other than the two intersecting rays have purposely been omitted from the figure. In practice, each templet usually contains many rays, and the problems of resection and intersection are solved simultaneously. Intersections are usually formed by more than two rays to check the procedure. (The common azimuth line  $p_1p_2$  is not shown in the figure.)

*3254 Principle of the Azimuth Line*

The azimuth line is of practical importance in radial plotting. An azimuth line is the radial line on a photograph or templet that also passes through the position of the radial center of an overlapping photograph or templet. An azimuth line of a photograph is determined by the radial center and the conjugate radial center. A conjugate radial center is the position on a photograph of the radial center of an overlapping photograph. Obviously, a conjugate center can only occur where the overlap is more than 50 percent. In practice, the conjugate radial center, which determines the azimuth line, is readily located by the use of a stereoscope. Obviously, an azimuth line on one photograph is duplicated on the overlapping photograph because each line connects the same two corresponding images. Inasmuch as each azimuth line is radial from its own center, and also passes through the other center, the azimuth line is a common line of the two photographs. Thus, in the adjustment of the radial templates, all common azimuth lines should be collinear, or lie one on top of the other, except where there is excessively large tilt in either photograph.

The presence and use of the azimuth lines in radial plotting, together with the principles of resection and intersection, enable one to construct a rigid and accurate system of graphic triangles to determine the map positions of images. Azimuth lines can be compared to backsights and foresights in planetable or transit traverse surveying.

*3255 The Radial Plot and Its Extension*

It is significant that the problems of intersection and resection and the use of azimuth lines are independent of the scales of the photographs and the elevations of the objects if the photographs are truly vertical. Furthermore, the intersected position is in its correct map position regardless of where the photographic image might have been along the radial line.

Theoretically, only two control points are needed in any radial plot, but in practice many more points are required to maintain map accuracy specifications. It is significant, however, that every templet need not be resected or fixed from ground control points. If any two overlapping templates are assembled without control points so that their common azimuth lines coincide, then any intersected positions are related correctly to one another, but the scale and geographic orientation of the intersected positions are not known. These two templates can be placed at any distance apart as long as their azimuth lines coincide and their separation fixes the scale of the intersected positions. Other adjoining overlapping templates can be added to the initial pair in an unending sequence and the scale of the assembly or plot will theoretically be that of the first pair. If intersections for any two horizontal control points occur anywhere in the assembly, then the scale can be determined by comparing the radial-plot distance with a known ground distance between corresponding points. Also, if the control points are plotted on a map projection or grid, then the scale of the plot can be expanded or contracted by reassembling the plot so that the templates are moved only along their common azimuth lines until the intersected control points are at the required separation. Then both the scale and the orientation of the plot are those of the map projection if the two intersected control points coincide with the respective plotted control positions. Templates can then be added to the plot with or without additional control and the radial plot is said to be "extended." The number of templates that can be added without additional control is obviously limited by accuracy considerations. This topic is discussed further in 42.

The applications of the principles of radial plotting thus enable the photogrammetrist to construct or compile a planimetric map (orthogonal projection) from two or more vertical photographs (perspective projections). The map positions for *all* the photographic images of significance can be determined from the photographs because there is theoretically no limit to the number of photograph images that can be intersected.

### 326 PARALLAX AND ELEVATIONS

*Parallax* is a measurable linear dimension that is related to the elevation of an object, and which exists for each pair of corresponding images on two overlapping photographs. Parallax difference is the principal element used in determining elevations from photographs and is the principal cause of stereoscopic vision. As might be expected from the general definition of the word, parallax is the apparent change in position of an object as observed from two different points (perspective centers). In practice the total parallax is sometimes considered as resolved into two perpendicular components, one of which is called *x*-parallax, which is related to elevations, and the other is called *y*-parallax, which is a hindrance to stereoscopic vision.

#### 3261 Stereoscopic Parallax

Absolute stereoscopic parallax  $p$  is defined as

$$p = x - x' \quad (3261A)$$

(see the small diagram of figure 3 10) for the images of an object on two overlapping untilted vertical photographs of equal focal lengths and equal flying heights where  $x$  and  $x'$  are the abscissas of the images as explained in the next paragraph. The parallax  $p$  is related to the elevation of the object  $h$ , the distance between the perspective centers  $B$  (air base), the focal length of the photographs  $f$ , and the flying height  $H$ , as shown by the equations

$$p = \frac{Bf}{H - h} \quad (3261B)$$

$$h = H - \frac{Bf}{p} \quad (3261C)$$

Consider two photographs, I and II, (see fig 3 10) without tilt taken from  $O$  and  $O'$  a distance  $B$  apart having equal focal lengths  $f$ , and equal flying heights  $H$ . The points  $a$  and  $a'$  are images on the separate photographs of the common object  $A$  of elevation  $h$  above some datum plane. Let  $x$  and  $y$  and  $x'$  and  $y'$  be the rectangular coordinates of  $a$  and  $a'$ , respectively, where the  $x$ -axes are chosen parallel to the air base  $OO'$  with  $+x$  to the right and the origin at the nadir points  $n$  and  $n'$ . (On an untilted photograph, the nadir point coincides with the principal point. See 341. The nadir points are used for convenience in symbolization.)

The ground nadir points  $N$  and  $N'$  are also of elevation  $h$  and are vertically beneath  $O$  and  $O'$ , respectively. Then the plane  $OO'N'N$  is vertical. Let  $A_1$  be the orthogonal projection of  $A$  in the plane  $OO'N'N$  and let  $a_1$  and  $a'_1$  be the images of  $A_1$ . The lines  $aa_1$ ,  $a'a'_1$ , and  $AA_1$  are mutually parallel because the photographs are not tilted. Also  $x = na_1$  and  $x' = n'a'_1$  are the abscissas of the images  $a$  and  $a'$ .

The insert shows the two triangles  $Ona_1$  and  $O'n'a'_1$  placed with their common side  $f$  in coincidence. Then the distance  $a_1a'_1 = p$  is defined as the absolute stereoscopic parallax for the pair of images, and equation 3261A follows. The image  $a'$  frequently occurs to the

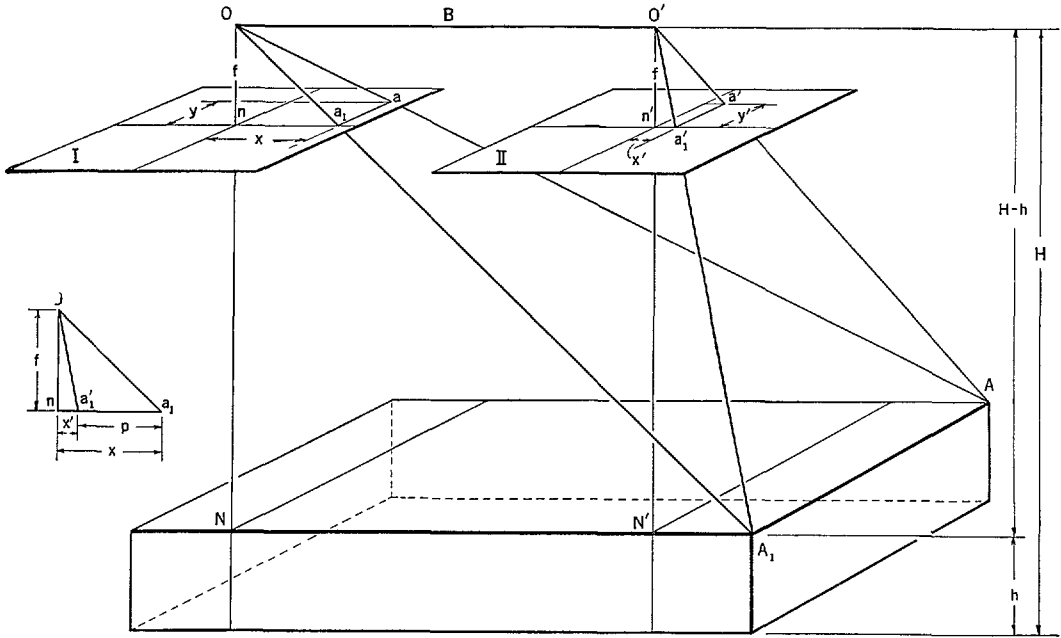

FIGURE 310—The principle of absolute stereoscopic parallax

left of  $n'$  on photograph II where the algebraic sign of  $x'$  becomes negative and the usual convention as to signs is observed

Consider triangle  $Oa_1a'_1$  of the small diagram, and triangle  $OA_1O'$  of the main figure. The line  $a_1a'_1$  is parallel to  $OO'$  because the photographs are not tilted and because the two flying heights  $ON$  and  $O'N'$  are equal. Line  $Oa_1$  of the insert is parallel to  $OA_1$  because the former was constructed parallel to  $Oa_1$  of the main figure where it is a part of  $OA_1$ . Similarly,  $Oa'_1$  of the insert is parallel to  $O'A_1$ . Therefore, the two triangles are similar because their sides are respectively parallel, and consequently their corresponding dimensions are proportional. (The corresponding altitudes of the two triangles are considered as corresponding dimensions, the altitude of triangle  $Oa_1a'_1$  in the insert is  $f$ , and that for triangle  $OA_1O'$  is  $H - h$ ) Then the relations can be written,

$$\frac{a_1a'_1}{OO'} = \frac{On}{ON}$$

$$\frac{p}{B} = \frac{f}{H - h}$$

from which equations 3261B and C are obtained by rearranging the terms algebraically

Equation 3261B indicates that the parallax value varies only with the four elements  $f$ ,  $B$ ,  $H$ , and  $h$ . No term is present that has to do with *where* the images appear on the photographs, and hence parallax is entirely independent of the location of the object as long as there is an image of the object on each photograph. Also, for a given pair of untilted photographs,  $f$ ,  $B$ , and  $H$  are of fixed values and the value of parallax  $p$  depends entirely on the one remaining variable term, namely, the elevation  $h$  of the object

*Example* The image of a hilltop on one photograph has an  $r$ -coordinate of + 50 mm and on another photograph - 40 mm. The focal length of the photographs is + 150 mm, the flying height is 12,500 feet, and the distance between the exposures is 7200 feet. Find the elevation of the hill

Solution

$$p = x - x' = 50 - (-40) = 90 \text{ mm}$$

$$h = H - \frac{Bf}{p} = 12,500 - \left(7200 \times \frac{150}{90}\right) = 500 \text{ feet}$$

This method of determining elevations is not employed much because it is more convenient to measure and to use *differences* in parallax. Absolute stereoscopic parallax is the basis for the parallax-difference relations

### 3262 Elevation Difference from Parallax Difference

The difference in elevation  $\Delta h$  of two objects is related to the difference in parallax  $\Delta p$  by the following equations in which  $H$  is the difference between the elevations of the camera and of the lower object

$$\Delta h = \frac{\Delta p H}{b + \Delta p} \quad (3262A)$$

$$\Delta p = \frac{b \Delta h}{H - \Delta h} \quad (3262B)$$

Let  $h_1$  and  $h_2$  be the elevations of the two objects and let their difference in elevation be  $\Delta h = h_2 - h_1$ . Also let  $p_1$  and  $p_2$  be the parallaxes of the two pairs of images in accordance with equation 3261B, and let the difference in parallax be  $\Delta p = p_2 - p_1$ . From equation 3261C,

$$h_1 = H - \frac{Bf}{p_1} \quad \text{and} \quad h_2 = H - \frac{Bf}{p_2}$$

Then,

$$\Delta h = \left(H - \frac{Bf}{p_2}\right) - \left(H - \frac{Bf}{p_1}\right) = Bf \left(\frac{1}{p_1} - \frac{1}{p_2}\right)$$

$$\Delta h = \frac{Bf(p_2 - p_1)}{p_1 p_2} = \frac{Bf}{p_1} \times \frac{\Delta p}{p_2}$$

Because  $\frac{Bf}{p_1} = H - h$  from equation 3261C, and because  $p_2 = p_1 + \Delta p$ , then,

$$\Delta h = \frac{\Delta p (H - h_1)}{p_1 + \Delta p}$$

This formula is general and exact, there having been imposed no approximations nor special conditions

Suppose that the lower object is at sea level so that  $h_1 = 0$ , or else the equivalent supposition that  $H$  is measured from the lower point upward to the perspective centers

Then from equation 3261B,  $p_1 = \frac{Bf}{H}$  or  $\frac{p_1}{B} = \frac{f}{H}$ , and according to equation 3222B,  $p_1$

is the photographic image of the air base  $B$  at the scale  $\frac{f}{H}$ . The letter  $b$  can then be used logically in place of  $p_1$ , and equation 3262A is the result. Equation 3262B is obtained from 3262A by algebraic rearrangement of the terms

Equation 3262A is widely used where elevations are determined from photographs without the use of a precise stereoscopic plotting instrument. The equation is exact only where  $H$  is measured from one of the objects, but if  $H$  is not known exactly, the effect is not serious in practice because the value is known sufficiently close that any resulting errors are insignificant. The value of  $b$  is frequently obtained by taking the average of the two distances from the principal point to the apparent position of the other principal point (the

distance between the principal point and the conjugate principal point) If the terrain at the conjugate principal point is not at elevation  $h_1$  or  $h_2$ , then the value  $b$  is in error because of relief displacement The value  $b$  can also be measured conveniently from an accompanying radial plot that was assembled at or near the scale of the photographs A small error in  $b$  is not critical because the total value is comparatively large and because the errors due to tilt are apt to be much larger If the value  $\Delta p$  is relatively small, it can be eliminated from the denominator of equation 3262A to facilitate slide rule computation

The value  $\Delta p$  in the numerator is extremely critical Because of the small value of  $\Delta p$ , a small actual error is a relatively large percentage of the total value, and the resulting elevation is affected in the same proportion

*Example* The distance between the principal point and the conjugate principal point is 84.7 mm on one photograph and 86.1 mm on the other The parallax difference for the pairs of images at the base and the top of a tall stack measures 1.22 mm If the flying height is 14,000 feet above the ground, what is the height of the stack?

*Solution*

$$b = \frac{1}{2}(84.7 + 86.1) = 85.4 \text{ mm}$$

$$\Delta h = 1.22 \times 14,000 \div (85.4 + 1.22) = 197 \text{ feet}$$

The value  $\Delta p$  can be measured with a parallax measuring stereoscope (stereocomparator) (see chapter 6), or it can be measured with ordinary drafting instruments, as follows

- (1) Lay the two photographs alongside each other (see fig. 3.11) so that the four principal points and conjugate principal points are all in the same straight line, and so that the separation of the photographs is any convenient distance
- (2) Set a pair of dividers (or a beam compass) to span the distance between one pair of corresponding images, as  $a$  and  $a'$
- (3) Construct through one of the other images  $c$  a segment of the line  $cc'$  that joins these two images, such as the segment  $ca''$
- (4) Transfer the dividers to the second pair of images so that one end of the dividers is at one of the other images  $c'$  and the other end of the dividers is on the line segment, as at  $a''$
- (5) Then the distance  $ca''$  is the difference in parallax which can be measured by any convenient method for use in equation 3262A

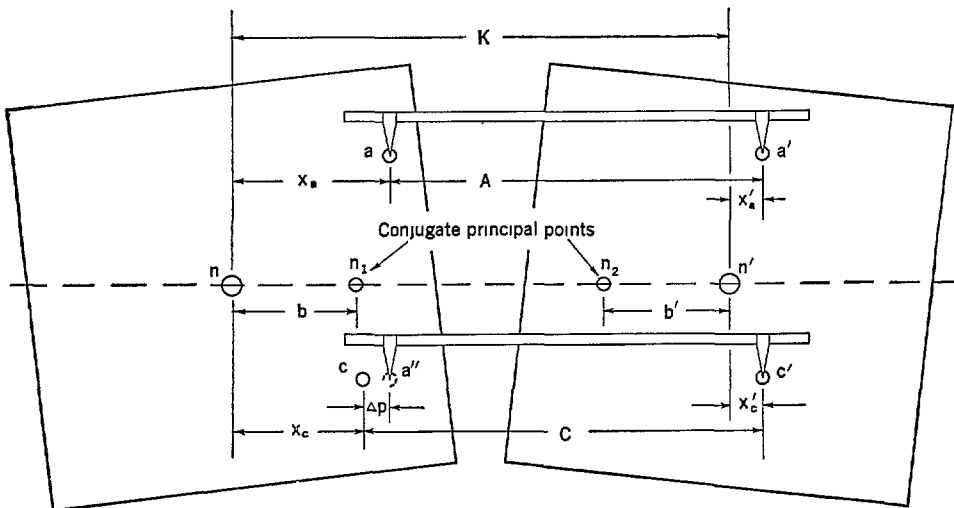

FIGURE 3.11—How difference in parallax can be measured with dividers



The proof of this method consists of the addition and subtraction of certain distances to show that  $ca'' = \Delta p$ . With reference to figure 3 11,

$$\begin{aligned} A &= K - r_a + r_{a'} = K - (r_a - r_{a'}) = K - p_a \\ C &= K - r_c + r_{c'} = K - (r_c - r_{c'}) = K - p_c \\ ca'' &= C - A = (K - p_c) - (K - p_a) = p_a - p_c = \Delta p \end{aligned}$$

Great caution must be exercised in determining elevations by these methods, principally because the formulas were derived assuming a complete absence of tilt. The accuracy of the elevation difference in the example is normally about  $\pm 15$  feet where the two images ( $a$  and  $c$  in figure 3 11) are less than about 1 inch apart. But errors may increase very rapidly as the distance becomes greater between the images for which the difference in elevation is being determined. Logical corrections can be made if there exist enough known elevations to indicate the trend of the errors. The complete mathematical consideration of the effect of tilt is difficult, but the problem is easily solved with stereoscopic plotting instruments.

### 3263 *Y-Parallax*

*Y*-parallax is defined as

$$p_y = y - y'$$

in the manner similar to the definition of stereoscopic parallax (3261). *Y*-parallax is zero and nonexistent if the two photographs are not tilted, are of equal focal length, and of equal flying height. A failure in the observance of any one of these three conditions causes the value of *y*-parallax to be other than zero. Hence, the presence of *y*-parallax indicates that one or more of the three conditions has been violated, furthermore *y*-parallax can be used as a means for measuring and/or correcting the photographs. The development of the relation of *y*-parallax to tilt, focal length difference, and flying height difference is beyond the scope of this manual. *Y*-parallax can also be created by the failure to orient photographs correctly for viewing with a stereoscope. When using tilted (not truly vertical) photographs in simple stereoscopic instruments, *y*-parallax is removed for visual purposes in each local area either by shifting one of the floating dots in the *y*-direction, or by shifting one of the photographs. *Y*-parallax caused by tilt and scale can be eliminated for the entire area of overlap either by first rectifying one or both of the photographs, or by the equivalent operation of tilting one of the photographs for viewing, which is practiced on many precise stereoscopic plotting instruments.

The absence of *y*-parallax under ideal conditions can be shown by considering figure 3 10. In the similar triangles  $OAA_1$  and  $Oaa_1$ ,

$$\frac{aa_1}{AA_1} = \frac{f}{H - h}$$

In the similar triangles  $O'AA_1$  and  $O'a'a_1$ ,

$$\frac{a'a_1}{AA_1} = \frac{f}{H - h}$$

Hence,  $aa_1 = a'a_1$ . Because  $y = aa_1$  and  $y' = a'a_1$ , then  $y = y'$  and  $y - y' = 0$ .

### 3264 *Relation Between Parallax Difference and Relief Displacement*

Difference in parallax is also equal to the sum of the projections of the relief displacements on the azimuth line. For example, the parallax difference for the image of an

elevated object (fig 3 12) is equal to the distance  $b'c'$  which is composed of the sum of the orthogonal projections  $a'b'$  and  $a'c'$  of the relief displacements  $ab$  and  $ac$  on the azimuth line  $nn'$ . The principle is noteworthy for two reasons (a) the relation between parallax and relief displacement is vividly demonstrated, and (b) a basis is laid for considering the orientation of a pair of photographs that will cause maximum stereoscopic sensation (see 3335).

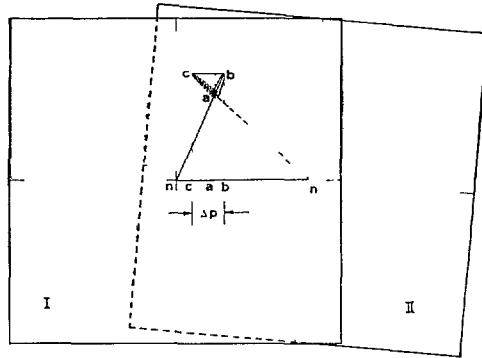

FIGURE 3 12—The relation of parallax difference to relief displacement

The figure shows two overlapping photographs as though they were printed on transparent material. The photographs are not tilted and have equal focal lengths and equal flying heights. The ground objects  $N, N'$ , and the base  $A$  of the figure all have zero elevation. Hence the photographs can be superposed so that the corresponding principal points and conjugate principal points and the images of the base of the object all coincide. The image of the top of the object is at  $b$  on photograph I and at  $c$  on photograph II. Then the relief displacement of the object is the distance  $ab$  on photograph I and  $ac$  on photograph II. The projection lines  $aa', bb',$  and  $cc'$  are all perpendicular to the azimuth line  $nn'$ . It is to be shown that the difference in parallax  $\Delta p$  for the images of the top and the bottom of the object is equal to the sum of the projections  $a'b'$  and  $a'c'$ . By equation 3261A,

$$\begin{aligned} p_a &= x_a - x_a' \\ p_{bc} &= x_b - x_c' \\ \Delta p &= p_{bc} - p_a = x_b - x_c' - x_a + x_a' \end{aligned}$$

But  $x_a = na'$  and  $x_b = nb'$ . Also  $x_a' = -n'a'$  and  $x_c' = -n'c'$ , where the negative signs result from the fact that these coordinate values are measured to the left of their origin  $n'$  in the usual negative geometric sense. Then, by substitution,

$$\begin{aligned} \Delta p &= nb' - (-n'c') - na' + (-n'a') \\ \Delta p &= nb' + n'c' - na' - n'a' \\ \Delta p &= (nb' - na') + (n'c' - n'a') = a'b' + a'c' \end{aligned}$$

Although the method of proof is not entirely general, it can also be shown in a similar manner that the principle is valid for any two pairs of images.

### 327 ANALYTIC PROBLEMS

Two problems exist that are fundamental to theoretical photogrammetry and that are related to untilted photographs (1) to find the *exact* flying height where the camera focal length, the horizontal distance between two ground stations, and the elevations of the two stations are known, and (2) the inverse, to find the *exact* ground distance between two

stations where the camera focal length, the elevations of the two stations, and the exact flying height are known. The existence of the problems is due to the fact that equation 3222C  $\left(\frac{ab}{AB} = \frac{f}{H-h}\right)$  does not apply where the two objects have different elevations. The solutions have little or no direct application in practical photogrammetry, but they are used in an exact method of tilt determination. The two topics are considered in reverse order for convenience. The analysis is based on rectangular plane coordinates of images on a photograph measured with an accurate measuring device, such as a comparator. The accuracy of the final values is exactly consistent with the accuracy of the initial measurements, and is entirely independent from discrepancies which ordinarily result from graphic construction, or analytic approximations which sometimes occur when problems of this nature are encountered.

Equation 3222C was based on the assumption that the objects  $A$  and  $B$  were of equal elevation. If the objects are not of equal elevation, the average elevation for the value of  $h$  in the equation does not yield the correct result. Furthermore, the application of relief displacement to either or both images introduces graphic errors and is not adaptable to tilted photographs. An average value for  $h$  is frequently used in practice inasmuch as the error is not serious if the elevation difference is less than about one percent of the flying height.

#### 3271 To Find the Exact Ground Distance

Let the two elevations of two objects on the ground be  $h_A$  and  $h_B$ , and let the coordinates of the corresponding photograph images be  $x_a, y_a, x_b,$  and  $y_b$ . The origin for the coordinates is the principal point (also the nadir point) and the reference axes can have any convenient orientation. It is customary to let the fiducial marks determine the axes, with the  $+x$ -direction being that of the general direction of flight. It is assumed that the flying height  $H$  and the focal length  $f$  are known. Let  $X_A, Y_A, X_B,$  and  $Y_B$  be the plane coordinates of the ground objects  $A$  and  $B$  such that the ground coordinate axes are parallel, respectively, to the photograph coordinate axes, but which are in no way related to any geographic system of plane coordinates. Then from equation 3222C

$$X_A = \frac{x_a (H - h_A)}{f} \quad (3271A)$$

where  $x_a$  and  $X_A$  correspond to  $ab$  and  $AB$ , respectively, of the original equation. Here only one elevation is encountered, and a horizontal datum distance is obtained from the ground nadir to the object—a distance that is independent of elevation. Similarly,

$$Y_A = y_a \frac{H - h_A}{f}$$

$$X_B = x_b \frac{H - h_B}{f}$$

$$Y_B = y_b \frac{H - h_B}{f}.$$

Then the horizontal distance  $AB$  between the two objects can be obtained from the four horizontal ground coordinates, as in analytic geometry, from the relation

$$AB = \sqrt{(X_A - X_B)^2 + (Y_A - Y_B)^2} \quad (3271B)$$

or 
$$AB = \sqrt{\Delta X^2 + \Delta Y^2}.$$

*Example* The data and computation are arranged below in tabular form. The flying height is 14,000 feet and the focal length is 200 mm. The problem is to find the exact ground distance between the objects *A* and *B*.

Solution

Measured data					Computation						
	<i>x</i> , mm	<i>y</i> , mm		<i>h</i> , ft	<i>H</i> - <i>h</i>	( <i>H</i> - <i>h</i> ) - <i>f</i>	<i>X</i>	<i>Y</i>	Δ <i>X</i>	Δ <i>Y</i>	<i>AB</i>
<i>a</i>	+200	+150	<i>A</i>	500	13500	67.5	+13500	+10125	+33500	+28875	44227
<i>b</i>	-320	-300	<i>B</i>	1500	12500	62.5	-20000	-18750	-----	-----	-----

The exact ground distance is 44,227 feet

If this problem had been computed by the method or equation 3222*C* directly

$$ab = \sqrt{(x_a - x_b)^2 + (y_a - y_b)^2} = 687.68 \text{ mm}$$

$$\text{Average } h = \frac{1}{2} (1500 + 500) = 1000$$

$$AB = \frac{ab(H - h)}{f} = \frac{687.68(14,000 - 1000)}{200} = 44,699 \text{ feet, which is in error 472 feet}$$

### 3272 To Find the Exact Flying Height

The exact flying height is determined by a method of successive approximation which yields a result that is exactly consistent with the given data. The indirect method is used because (1) it is just as short as a direct solution, and (2) it is a type of solution that is very similar to that used where tilt is considered (see 346) for which there is no choice of methods.

The method consists of (1) obtaining a logical trial value of the flying height from whatever source is convenient, (2) using this value with equations 3261*A* and *B* to obtain a corresponding trial ground distance between two objects of known separation, (3) adjusting the trial flying height value in accordance with the distance error, and (4) repeating steps (2) and (3) until the trial ground distance is correct to any desired limit of error.

The initial trial flying height *H<sub>t</sub>* can be the value reported by the aerial photographer, or it can be computed from equation 3222*C* using the average value of *h<sub>m</sub>*.

$$H_t = h_m + f \frac{AB}{ab}$$

where *ab* can be scaled from the photograph, or computed from the photograph coordinates using

$$ab = \sqrt{(x_a - x_b)^2 + (y_a - y_b)^2}$$

Let the trial ground distance be (*AB*)<sub>*t*</sub> as obtained by equations 3271*A* and *B* using *H<sub>t</sub>*. Then a logical, better value *H* can be found from the following relation for which no derivation is given

$$H = h_m + (H_t - h_m) \frac{AB}{(AB)_t} \tag{3272}$$

Here, only the variable altitude (*H<sub>t</sub>* - *h<sub>m</sub>*) of the aircraft above the mean ground elevation is corrected. If too great a value for *H<sub>t</sub>* had been used, then (*AB*)<sub>*t*</sub> would also be too large, hence, in equation 3272, the ratio (*AB*)<sub>*t*</sub> would tend to make the new value *H* smaller than *H<sub>t</sub>*, which is as desired. This value for *H* will result in the correct value for *AB* if the elevation difference is not extreme. In the following example, a second adjustment of *H* is required because of the large elevation difference.

Example Given

	r in mm	y in mm		h in ft
a	+ 200	+ 150	A	500
b	- 320	- 300	B	1500

Also,  $f = 200$  mm and  $AB = 44,227$  feet Find the exact flying height

Solution As in **3271**,  $ab = 687\ 68$  mm

$$\begin{aligned} \text{Trial flying height } H_t &= 1000 + (200) (44,227) - 687\ 68 \\ &= 1000 + 12,863 \\ &= 13,863 \text{ feet} \end{aligned}$$

Using  $H_t = 13,863$ ,  $(AB)_t$  is computed

	r	y		h	$H_t - h$	$(H_t - h) - f$	X	Y	$\Delta X$	$\Delta Y$	$(AB)_t$
a	+200	+150	A	500	13363	66 815	+13363	+10022	+33144	+28566	43755
b	-320	-300	B	1500	12363	61 815	-19781	-18544	-----	-----	-----

As  $(AB)_t$  is not equal to the given value for  $AB$ ,  $H_t$  is adjusted

$$H = 1000 + (13863 - 1000) (44227) - 43755 = 1000 + 13002 = 14002$$

Using  $H = 14002$ ,  $AB$  is again computed

	x	y		h	$H - h$	$(H - h) - f$	X	Y	$\Delta X$	$\Delta Y$	$AB$
a	-----	-----	A	-----	13502	67 510	+13502	+10127	+33505	+28880	44234
b	-----	-----	B	-----	12502	62 510	-20003	-18753	-----	-----	-----

As the value  $AB$  is still in error, another adjustment is required

$$H = 1000 + (14002 - 1000) (44227) - (44234) = 1000 + 13000 = 14000$$

Using  $H = 14,000$  in the third computation gives values exactly like those in the solution to the example in **3271**, showing that 14,000 feet is the exact flying height because it results in the correct ground distance

### 33 STEREOSCOPY

Stereoscopy is the science and art that deals with vision with two eyes that results in a mental sensation of three dimensions. An attempt is made in this section to explain the basis of stereoscopy as related to the mechanical operation of the eyes. An explanation is given for the exaggerated idea of heights one obtains when he views a pair of aerial photographs with a stereoscope, and why the degree of exaggeration is different under various viewing conditions. The relation of relief displacement and parallax difference to stereoscopic perception is shown. Suggestions and stereograms are included for training one to view photographs stereoscopically, and instructions are given for orienting a pair of photographs for viewing with a stereoscope.

#### 331 THE HUMAN EYE

A review of the facts and a few comments concerning the mechanical structure of the human eye may be helpful in understanding the operation of the eyes in using stereoscopic as well as other optical instruments. Figure 3 13 is a diagram showing a horizontal section through the right eye (see footnote in **31**). Light enters through a thin membrane called the *cornea*, passes through the liquid *aqueous humor*, proceeds through a capsule of jelly-

like material misleadingly referred to as the crystalline lens, traverses the jelly-like *vitreous humor*, and is finally brought to a focus to form a real image on the *retina*. A fine network of light-sensitive nerve ends on the retina transmit their sensations to the mind by way of the *optic nerve*. The index of refraction of each of the optical substances is about the same as for water, with that of the lens being somewhat greater. Each of the substances through which the light passes is an integral part of the optical lens system of the eye.

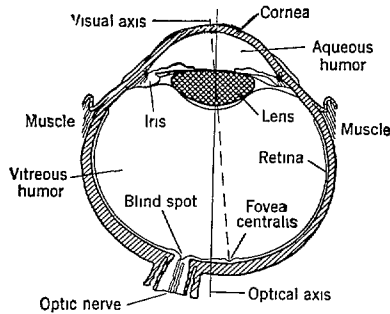

FIGURE 3 13 —Horizontal cross section of the right eye

The aperture stop for the eye is an adjustable diaphragm known as the *iris*. It opens and closes automatically, contracting under brilliant illumination and expanding under dim light, thus changing the size of the opening (the *pupil*) through which light enters the eye. The maximum size of the pupil is regarded as about 8 mm, which places a practical limit on the largest size that is needed for aperture stops of eyepieces for optical instruments. The property of changing the size of the pupil is known as *adaptation*. Thus, the iris tends to control the brightness of the retinal image regardless of the brightness of the illumination of the object, and for this reason the eye is not an accurate light meter.

Most of the refraction of light in being brought to focus on the retina occurs at the first surface of the cornea. A change in focus to adjust the eye for different object distances is made by the lens whose shape is changed automatically by muscular action. This ability is known as *accommodation*. The range and speed of accommodation usually decreases with age, the explanation being that the eye lens tissues become less pliable so that a change in shape becomes difficult or impossible. It is also argued that accommodation is assisted by a change in the shape of the eyeball so as to increase or decrease the image distance.

The retina is a sensitive screen on which the image is formed. The ends of the nerve fibers consist of microscopic structures known as *rods* and *cones*. The visual center of the retina, the *fovea centralis*, in most individuals consists exclusively of cones. Outside this center, rods occur in increasing numbers and cones in decreasing proportion. The cones seem to be associated with acute daylight vision, for in order to study an object closely, the eye automatically rotates to bring the image onto the fovea where the cones are closely packed. The rods appear to be associated with night vision and dim illumination. The field of distinct vision in daylight is surprisingly small—about  $1^\circ$  in angular extent—whereas the rest of the visual field is used something like a finder for selecting images which are to be brought onto the fovea for closer examination. Thus, in reading, the eye shifts from word to word bringing each in turn onto the fovea, the action being accomplished by a rotation of the eyeballs in their sockets through the action of the eye muscles.

The cones in the fovea vary in size from about 0.0015 to 0.0050 mm in diameter. The cones in the outer regions are much larger. These dimensions set a physiological limit to the fineness of detail that can be distinguished, because a cone is fully sensitized if light is incident on any part of it. The cones thus tend to limit resolution or visual acuity in the same way that grain does in a photographic emulsion, although at times the eye performs much better than one should expect from these considerations. The normal eye working under favorable conditions is capable of aligning two fine lines with an error usually less than 10 or 12 seconds of angle. This *vernier acuity* is inexplicably as low as two seconds in some individuals. The limit of *stereoscopic acuity* corresponds closely to that of vernier acuity. The size of the retinal image in meters can be obtained from the relation

$$y = 0.015 \frac{Y}{L}$$

where  $Y$  is the dimension in the object corresponding to  $y$ , and  $L$  is the distance from the eye to the object. The focal length of the lens of the eye for distant vision is considered as being about 21 mm and changes to about 19 mm for normal reading distance.

The two eyes are capable of rotating in their sockets simultaneously and also, to a lesser extent, separately. This independent horizontal rotation is known as *convergence* which enables the centering of both retinal images on their respective fovea for objects far and near. The independent vertical rotation is normally very slight but becomes noticeably developed in operators of stereoscopic instruments. The eyes can thus become somewhat *tolerant* to a lack of vertical alignment of a pair of images.

The elements accommodation and convergence are somehow linked together in normal vision. When the eyes converge on an object so as to place the retinal images on their respective fovea, the eyes also automatically accommodate so as to form a sharp image. Thus, the convergence of the eye might be compared to a range finder that automatically notifies the accommodation element what distance to use in focusing. The photogrammetrist, however, sometimes needs to interrupt this relationship between convergence and accommodation so that his eyes will diverge as in distant vision but will accommodate for ordinary reading distance. This is done in examining a stereoscopic pair of photographs without the aid of a stereoscope and is often done to some extent continuously by operators of stereoscopes and stereoscopic instruments.

If the eye is suddenly exposed to light, an appreciable time elapses before there is a mental response. When the light is extinguished, there is again a time lag before the sensation stops. If the light appears and disappears with increasing rapidity, a critical frequency is eventually reached at which the light source appears to be constant in brightness. The critical frequency varies from about 10 to 40 cycles per second depending to a large extent on the brightness of the object. This characteristic is known as *flicker sensitivity* or *persistence of vision*. It is the basis for the use of flicker spectacles in stereoscopic observations, and also for motion pictures and the stroboscope.

The lens muscles and the rotating muscles of the eye are usually relaxed if a distant object is being viewed. Effort is spent in the design of optical instruments to deliver image rays to the eye in such a way that they appear to come from infinity (parallel light) in order to lessen the element of eye fatigue. It is usually possible to obtain a slightly larger image by placing a magnifier closer to the object to cause the object rays to diverge somewhat as though coming from the usual reading distance, but the eye muscles are then in tension and are subject to fatigue if they are subjected to long operating conditions. From this consideration, an optical aid such as a reading glass, magnifier, lens stereoscope, or

eyepiece should be used so that the distance from the glass to the subject is equal to the focal length of the lens for maximum eye comfort

The eye as an optical instrument can be compared to a modern aerial camera. The eye, as explained above, has a clear angular field of only about  $1^\circ$ , whereas current aerial cameras have fields of view of  $90^\circ$ . The resolution of the eye retina is about one minute at the fovea and decreases rapidly for other parts of the retina, whereas that of a common wide-angle camera is about one-half minute over nearly all the angular field of view. The maximum speed of the eye is about  $f/2.5$  whereas that of a current wide-angle lens is  $f/6.3$ . Whereas the retina is sensitive only to the usual visual range of colors, photographic emulsions can be made sensitive also to invisible infrared and ultraviolet light. The eye might be affected by any of the aberrations common to lenses and might require correction in the form of spectacles. Some of the aberration difficulties encountered in lenses are partly solved in the eye by the use of a curved or bowl-shaped image screen or retina. The eye, of course, possesses the element of fatigue which tends to reduce greatly its efficiency of operation in every respect.

### 332. THE SENSATION OF RELIEF

Normal vision includes the sensation that some objects are nearer the observer than others. The phenomenon is frequently referred to as depth perception. The greatest single element affecting the perception of depth lies in the fact that one observes an object with two eyes which are separated a fixed distance and which act somewhat like a range finder.

Vision, as indicated previously, is purely a mental sensation. The retinal image is transmitted to the mind by means of nerve connections, to produce a mental picture of the object. The retinal image conforms to the rules of perspective projection and is regarded as a perspective view, with the pupil as the perspective center. Owing to the fact that the pupils of the eyes are separated, the perspectives thus formed are usually not identical. The mind receives the two slightly different views and responds with a mental impression of three dimensions which is called a *stereoscopic model*. Just how the mind performs this function is perhaps a mystery, and need not be considered further here. It is sufficient to know that the mind has learned to accept the different images and interpret them as resembling a solid replica of the object. It is further realized that sufficient geometric data are contained in the two perspective views obtained from perspective centers which are separated by a fixed interpupillary distance, so that the object could be reconstructed in three dimensions.

The stereoscopic sensation can also be created artificially by impressing on the two retinas proper perspective views (photographs) in such a manner as to simulate the natural conditions of observing the object itself. This can be done in any of a number of different ways of observing two different overlapping photographs separately, such as (a) without any optical aid, (b) with a stereoscope of the lens, mirror, or prism type described in 144, (c) with spectacles of complementary filters as in viewing anaglyphs, the multiplex, and certain three-dimensional movies, (d) with polaroid spectacles of opposite alignment as in viewing vectographs and three-dimensional movies in color, (e) with synchronized flicker spectacles as used in certain stereoscopic instruments, or (f) with a vertical lenticular grating as used in certain novelties and advertising displays. The function of each of these methods is identical, namely, to transmit to each retina separately a different perspective view as made by photography from two different camera stations.



One should bear in mind that every photograph possesses a unique center of perspective—a point in space off the surface of the photograph a distance equal to the principal distance and on a line perpendicular to the plane of the photograph at the principal point. If one eye is placed at the perspective center of a photograph, the images appear to be in exactly the same relationship as they would appear if the object itself were viewed from the point at which the photograph was taken. A second photograph of the same object, taken from a different point and observed with the other eye placed at its perspective center, completes the necessary condition to cause the same solid mental impression that might have been experienced if the eyes themselves had occupied the original camera stations.

Figure 3 14 illustrates the principles of artificial stereoscopic impression. Suppose the left eye to be at the point  $O$  and the right eye at  $O'$ , and consider that a cube  $I-L$  is observed. If two sheets,  $p$  and  $p'$ , of transparent material, such as glass, are placed in the same plane between the eyes and the object, the points  $i$  and  $i'$ , for example, both appear to coincide with the object point  $I$ . If the cube is removed the points  $i$  and  $i'$  continue to appear to coincide at the original position  $I$  in space. Similarly, each of the corners of the cube remain to be visualized by virtue of the fact that corresponding pairs of image points like  $i$  and  $i'$  appear to be in coincidence. Thus, two systems of points and lines on the transparent sheets repeat on the respective retinas the same image positions that were experienced when the cube itself was being viewed. The mental processes interpret these two impressions in the same manner as they did with the original object—a solid of three equal dimensions.

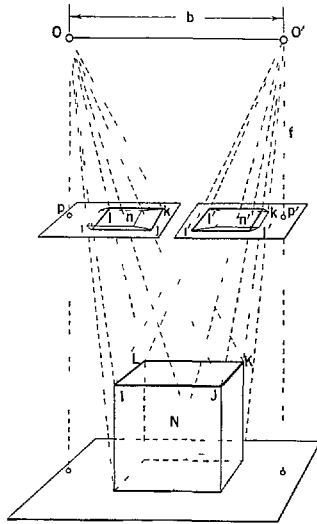

FIGURE 3 14—Principle of stereoscopic photographs

The transparent sheets,  $p$  and  $p'$ , are identical to photographs (contact prints) with their perspective points at  $O$  and  $O'$  and having focal lengths  $Op$  and  $O'p'$ . If the contact prints of pairs of photographs are observed in their proper orientation with the eyes placed at the two respective points of perspective, then the mind interprets the view in its true three-dimensional form as with the cube and the transparent sheets, with the added convenience of realistic and helpful shading. Ordinary overlapping aerial photographs usually furnish satisfactory pairs for obtaining a three-dimensional view of the terrain with its hills, mountains, valleys, and cultural features.

333 DEFORMATIONS IN THE STEREOSCOPIC MODEL<sup>2</sup>

Section 332 illustrates the manner in which two photographs can be viewed to yield a relatively true stereoscopic model. The conditions are assumed, for convenience, to be ideal. The term *ideal conditions* is used here to mean that the two planes of the negatives of the stereoscopic pair of photographs are in the same plane at the time of exposure, and also that the photographs are viewed with each pupil at the perspective center of its respective photograph—a feat usually impossible to perform in practice. The present discussion deals with effects of using photographs in a manner other than the ideal. It has been observed, and is illustrated here, that the stereoscopic model is deformed in shape when the ideal conditions are not observed and different types of deformations result from the different manners of violating the ideal conditions. The causes of the various types of deformations are outlined as follows:

1 Manner of taking (noncoplanar photographs caused by conditions present at time photographs were made)

11 Camera axes parallel but inclined, or unequal flying height

12 Camera axes not parallel (camera tilt, axes convergent or divergent)

2 Manner of viewing

21 Change in eye base

22 Change in viewing distance

23 Movement of head

24 Separation of the photographs

25 Orientation of the photographs

The above causes are discussed separately, beginning with the second group because they are simpler to demonstrate. The effects are illustrated by considering a transparent square (fig. 3 15) located a convenient distance in front of the eyes and midway between them, and in which the plane of the square, extended, also contains the eye base  $OO'$ . A square is used instead of a cube because of its simplicity in illustration, and because each element of the cube can be considered in a like manner to obtain similar general results.

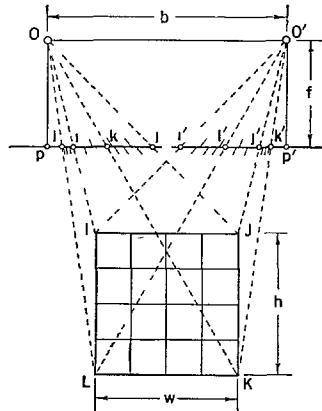

FIGURE 3 15—Taking condition and also the "ideal condition" for viewing

The lines  $p_j$  and  $i'p'$  represent the two picture planes, being in the same plane and at a principal distance  $f$  from the perspective centers  $O$  and  $O'$ , which are a distance  $b$  apart. The points on  $p_j$  and  $i'p'$  then correspond to points on photographs made from  $O$  and  $O'$ .

<sup>2</sup> Clerc, L. P., *Photography theory and practice*, pp. 506-532,  
 ———, *Applications de la photographie*, chap. 5.

with focal lengths  $f$ . If such photographs are viewed in the manner indicated, then the original square  $I-L$  is sensed, having the width  $w$  and height  $h$ . This assumes the ideal viewing conditions. The separate deformation diagrams are obtained by using these same points,  $i$  to  $j$ , and  $i'$  to  $j'$ , changing their relative positions as a unit with respect to  $O, O'$ , and reprojecting the lines  $O_i, O'_i$ , etc., representing paths of light, to obtain the intersections of corresponding pairs of lines which yield the points in the deformed figures. The principle is that the image positions in the picture planes of the ideal case impress positions on the retinas which are identical to the impressions derived from viewing the original square, whereas any change in the picture planes results in different image positions on the retinas, which correspond to impressions as might have been derived from some figure different from the original square.

### 3331 *Eye Base and Interocular Distance*

The distance between the cameras that take a pair of stereoscopic photographs and the distance between the eyes of the observer affect only the *scale* of the stereoscopic model and do not deform the model in any other way, if the photographs are viewed in the ideal manner. The only difference between figure 3 15 and figure 3 16 is that the distance between  $O$  and  $O'$  is changed from  $b$  to  $\frac{3}{4}b$ , respectively. The viewing distance is maintained, as are all the relative positions of points in the picture planes. The diagrams are placed so that each pupil occupies the correct perspective center.

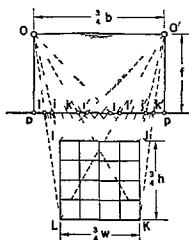

FIGURE 3 16—Deformation caused by a shortened eye base

It is quite obvious from the projection lines that the retinal impressions correspond to those that would have been caused by a square reduced to three-quarter size and brought closer to the observer, but changed in no other way—that is, all lines, angles, and distances would appear to be relatively the same as in the original. Consequently, in viewing a stereoscopic pair of aerial photographs in the proper manner, a scale model of the terrain appears, the ratio of which is equal to the eye base length divided by the camera air base length, the model appears nearer the observer in the same ratio, but the dimensions and angles all appear to be relatively true. This consideration also leads to the conclusion that two individuals with different eye bases perceive a stereoscopic model differing only slightly in scale, which is related directly to the individual eye bases.

### 3332 *Viewing Distance*

If a stereoscopic pair of photographs is viewed at an actual or a virtual distance that is different from the principal distance of the photographs, then the depth of the stereoscopic model is changed relative to lateral dimensions in the same proportion as the two

distances, but no other angular or dimensional deformations occur. This is illustrated in figure 3.17, which differs from figure 3.15 only in that the viewing distances  $O_p$  and  $O'p'$  are both changed to  $2f$ . By reprojecting the lines from the new positions of  $O$  and  $O'$  through the original picture point positions, a true rectangle is obtained whose width  $w$  is equal to that of the square, but whose height is twice that of the square. The effect is commonly referred to as relief exaggeration and is sometimes produced intentionally by using a mirror stereoscope of long viewing distance to inspect photographs of low-relief areas when delineating drainage. This cause is sometimes confused with a similar exaggeration due to photograph separation (see 3334).

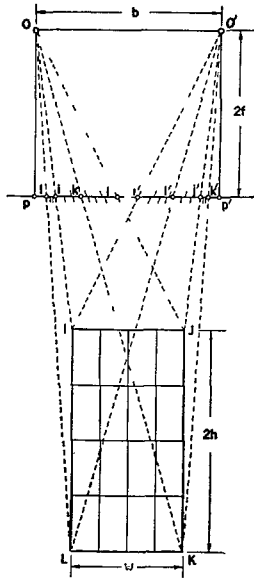

FIGURE 3.17 —Deformation caused by an increase in viewing distance

Because photographic enlargement or optical magnification also has the effect of increasing the principal distance, enlargement correspondingly decreases the relative exaggeration of depth or relief. Optical magnification, such as in the stereoplanigraph, increases the ability to make accurate measurements because of the enlarged detail, but the magnification also has the effect of flattening the appearance of the model. Conversely, decreasing the principal distance of a photograph increases the mental sensation of relief. For example, if a pair of multiplex diapositives, which are about one-fifth the size of the photographs, are viewed with an ordinary stereoscope, the relief seems to be extremely exaggerated. However, the ability to measure the apparent differences in heights is reduced because of the smallness of the photographic detail.

The effect of viewing distance can be demonstrated by observing a given pair of photographs with different types of stereoscopes. If one can view the images of a pair of overlapping photographs stereoscopically without a stereoscope, he can demonstrate the effect of viewing distance to himself by merely holding the photographs at different distances from the eyes. Perhaps the most vivid demonstration of the effect of viewing distance is in conjunction with the multiplex—the appearance of the relief is accentuated by moving the eyes vertically away from the platen.

3333 *Lateral Shift of the Eyes*

If a stereoscopic pair of vertical photographs is viewed with the eyes of the observer shifted laterally from the perspective centers, all the other viewing conditions being properly observed, then the images of elevated objects appear to lean from their true vertical positions toward the observer without changing the apparent dimensions of the images. The effect is illustrated in figure 3 18 which only differs from figure 3 15 in that the points of observation are  $O_2$  and  $O'_2$  rather than the perspective centers  $O_1$  and  $O_1$ . By reprojecting the lines from  $O_2$  and  $O'_2$  through the original image positions  $i, j, k$ , etc., a rhombus is formed instead of a square, in which the width and height are equal to those dimensions of the original square. This effect, and that of relief exaggeration, can be most vividly demonstrated by means of the multiplex apparatus. By elevating the head about 4 feet above the tracing table, the relief of the model appears to be tremendously exaggerated. Then if the head is swayed from side to side, the tops of elevated objects appear to sway, always pointing toward the observer.

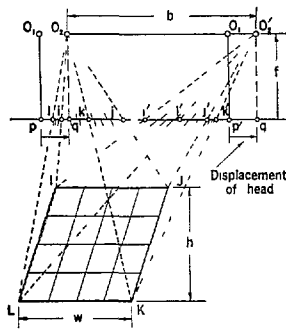

FIGURE 3 18—Deformation caused by a lateral movement of the eyes

3334 *Separation of the Photographs*

If a stereoscopic pair of photographs are separated so that the distance between perspective centers is greater than the eye base of the observer, the other viewing conditions being maintained in the correct relationship, then the height of an elevated object seems to be exaggerated and the base of the object seems to be enlarged relative to its top. In figure 3 19, the photographs are separated so that the points of perspective are moved from  $O_1$  to  $O_1'$  and from  $O_2$  to  $O_2'$ . The resulting figure is a trapezoid much larger than the original square, with the base enlarged more than the top. This is perhaps the most common type of image distortion because it is practically impossible to view two aerial photographs without separating them. The effect is usually thought of merely as relief exaggeration inasmuch as the trapezoidal effect is seldom detected.

It is necessary to separate two photographs to view them stereoscopically. For example, if two photographs are placed in a mirror stereoscope, they are separated or spaced so that an *image* on the right photograph appears at the center of vision for the right eye, and the corresponding *image* of the left photograph appears at the center of vision of the left eye, because that is the most comfortable position for viewing. The eyeballs then turn a small amount in their sockets so as to converge comfortably on the common images, so to speak, but the convergence is slight and approaches parallel vision or even divergence. However, if the photographs were to be viewed according to the "ideal con-

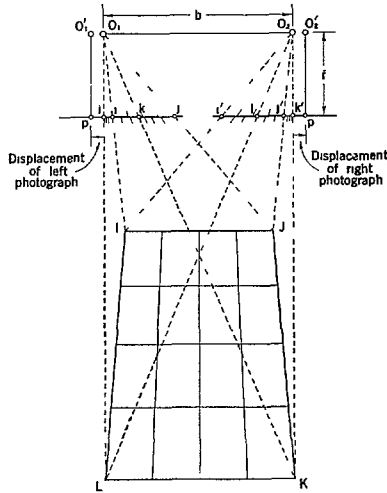

FIGURE 3 19 —Deformation caused by separation of photographs

ditions" that have been set up, then the photographs would have to be placed so that the *principal point* of the right photograph appeared at the center of vision of the right eye and the *principal point* of the left photograph appeared at the center of vision of the left eye. But this, obviously, is a physical impossibility if one is to focus his attention on pairs of common images rather than on different principal points. Consequently, photograph separation is an extremely common phenomenon. Moreover, the analysis of the effects of photograph separation serves as the only logical explanation of the cause of relief exaggeration where the viewing distance is equal to the focal length of the photographs.

3335 *Orientation of the Photographs*

The full mental sensation of relief is appreciated only if the photographs are oriented so that their common azimuth line is parallel to the eye base.

It is demonstrated in 3264 that parallax is a dimensional quantity associated with the elevation of the object and with the azimuth line direction of a pair of photographs. It is also shown that there is no element associated with elevation that is in a direction perpendicular to the azimuth line. Difference in parallax is shown to be equal to the length of a segment of a line parallel to the azimuth line. It is further shown in 335 that the mental perception of relief is caused by a linear separation parallel to the eye base, and any separation perpendicular to the eye base is called *y-parallax*, or lack of correspondence, and causes a confused image. Thus, *y-parallax* gives no sensation of relief.

In figure 3 20 the parallax difference is  $cc' = aa'$  which is the dimension that causes the stereoscopic impression of the elevation of the image. Suppose the eye base is inclined at an angle  $\theta$  to the azimuth line. Then the dimension  $bb'$  is the only dimension that is available to the eyes to cause the stereoscopic impression.

The segment  $bb'$  is the projection of  $aa'$  on a line parallel to the eye base, and by trigonometry,

$$bb' = aa' \cos \theta$$

If the eye base is parallel to the azimuth line  $\theta = 0^\circ$ ,  $\cos \theta = 1$ ,  $bb' = aa'$ , and the total parallax difference is available for the mind to interpret as difference in elevation.

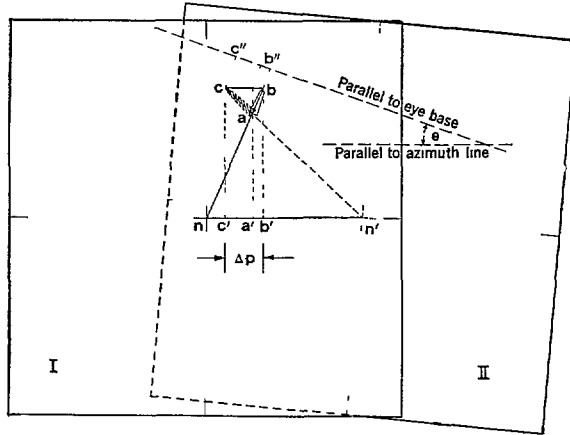

FIGURE 3 20—Effect of eye base not being parallel to azimuth line

But if  $\theta$  is any angle between  $0^\circ$  and  $90^\circ$ ,  $bb'$  is less than  $aa'$ , and the resulting impression of elevation difference is correspondingly less. If  $\theta = 180^\circ$ ,  $\cos \theta = -1$ ,  $bb' = -aa'$ , and the relief sensation is correspondingly negative, or pseudoscopic, so that hills appear as depressions and streams seem to flow along the tops of sharp ridges.

3336 Parallel Tilted Photographs

A stereoscopic pair of photographs is now considered in which the taking cameras are inclined an equal amount so that the image planes are not in the same plane but are in parallel planes. Figure 3 21 shows the square and the image positions of its intersections in much the same manner as figure 3 15, except for the inclination of the image planes or photographs.

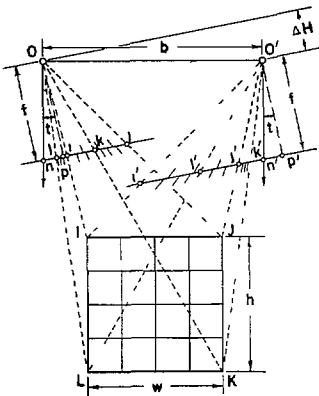

FIGURE 3 21—Condition in taking equally tilted photographs

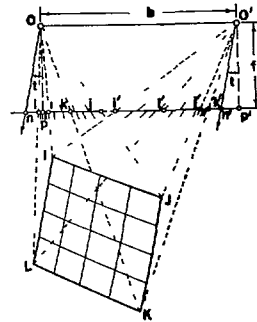

FIGURE 3 22—Deformation caused by equal tilt or by unequal flying height

However, nearly all photographs, whether they are inclined (tilted) or not, are placed in a common plane, such as on a table top, to be viewed stereoscopically. Such is the condition illustrated in figure 3 22 in which the pictures are viewed seemingly in the correct manner but the image positions relative to  $p$  and  $p'$  are those obtained in figure 3 21. The reprojection of lines through these points results in a distorted rhombus. It is apparent from figure 3 21 that this effect can also be caused by using two aerial photographs having

no tilt but taken at different flying heights. However, the simple figures shown here do not illustrate all the discrepancies that occur in a three-dimensional stereoscopic model. Mr. Clerc (see footnote in 333) shows that a flat surface is warped into a cylinder whose axis lies on a parabola. Moreover, if the camera axes are not in the vertical plane that contains the air base, the effect differs from that shown here, and is not entirely equivalent to a change in flying height. Y-parallax is also present throughout the model, whence it is sometimes possible to view stereoscopically only a small part of the overlap area with one setting, thence to shift one of the photographs a small amount for viewing a different part of the area.

### 3337 Unequally Tilted Photographs

If the photographs of a stereoscopic pair are tilted different amounts, the image is noticeably deformed in a somewhat irregular manner. In figure 3 23, the left photograph image positions  $i, j, k,$  and  $l$  are those obtained from the untilted condition shown in figure 3 15, and the left photograph image positions  $i', j', k',$  and  $l'$  are those obtained in the tilted plane of figure 3 21. The effects due to tilt of the aerial camera are dealt with more completely in contemporary instructions for the operation of stereoscopic plotting instruments, in which the model is said to be "warped" and an application of tilt and flying height differences are used to "flatten" the stereoscopic model. As in 3336, the complete effect is not illustrated by the simple figures shown here, and the effect is accompanied by the presence of y-parallax throughout the model.

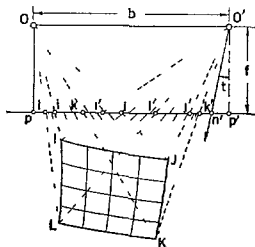

FIGURE 3 23 —Deformation caused by unequal tilt

### 3338 Combined Deformations

Many of the deformations of the stereoscopic model occur simultaneously and it is scarcely possible to isolate any one of the effects in practice. The most predominant distortion is that caused by the separation of the photographs for viewing and the resulting relief exaggeration. This is a desirable effect in many instances and is often complemented with an elongated viewing distance. The other deformations are usually not apparent unless an attempt is made to measure the stereoscopic model in a stereoscopic plotting instrument.

The creation of an undistorted stereoscopic model is usually attempted only in the use of precise stereoscopic plotting equipment. First, it is virtually impossible to view two photographic prints without separating their principal points greater than the interocular distance because of the wide common overlap of the photographs and also because of the inability of the eyes to function well under such a condition of divergence. Second, relief exaggeration is usually desirable as an aid to identification and interpretation because without exaggeration the terrain appears to be quite flat. In most stereoscopic plotting instruments, relief exaggeration due to viewing distance is desirable, but the other deformations cannot be tolerated and are eliminated to produce an undistorted map.



### 334. INSTRUCTIONS FOR ORIENTING PHOTOGRAPHS FOR STEREOSCOPIC VIEWING AND FOR STEREOSCOPIC TRAINING

A procedure for orienting a pair of vertical aerial photographs to be viewed with a stereoscope is presented in a series of three steps, and then a number of general remarks are made which may be helpful in initial training

1 Lay one photograph on the other so that the common detail of the overlap area is superposed. Then the line from the center of one photograph to the center of the other represents the azimuth or flight line. Sometimes it is convenient to draw the azimuth lines on each of the photographs (see 3254 and 4113)

2 Orient the pair of superposed photographs under the stereoscope so that the azimuth line is parallel to the eye base line of the instrument

3 Separate the photographs in the direction of the azimuth line, keeping the left photograph of the superposed pair on the left side of the stereoscope and not rotating either photograph

The amount of separation of the photographs depends on personal preference, on the particular type of stereoscope being used, and on the ability of the operator to allow his eyes to diverge. The separation for the simple lens stereoscope is only 2 or 3 inches, whereas the separation for the large prism stereoscope made for nine-lens photographs is about 3 feet. The difference in the interocular distances of two operators usually has very little to do with the amount of separation of the photographs. Therefore, the separation of the photographs and the separation of the lenses (if a lens stereoscope is used) are adjusted for the comfort of the individual. The ability to separate the photographs farther is improved by experience with little or no thought on the part of the photogrammetrist. To facilitate the separation of the photographs, place the index finger of the right hand on a prominent image in the overlap area of the right photograph and the index finger of the left hand on the corresponding image of the left photograph, look into the stereoscope to see the two index fingers separately, shift the two photographs parallel to the azimuth line until the index fingers appear as though they were superposed, withdraw the fingers and observe the prominent image instead, if necessary, move one of the photographs toward or away so as to make the two images exactly coincide to form a single clear stereoscopic model. Practice will remove the necessity for using the fingers, only the images having to be used.

Where azimuth lines have been placed on the photographs, the two lines should appear as a single line parallel to the eye base if the photographs are oriented correctly. Thus, the photographs can be oriented while they are being viewed in the stereoscope merely by observing the azimuth lines, and pushing the photographs closer together or farther apart until a pair of images come together to form a single stereoscopic image. Another method to assure that photographs with azimuth lines are oriented correctly is to place a straightedge on the two photographs under the stereoscope so that the two azimuth lines are in the same straight line, and so that the straightedge is parallel to the eye base of the instrument. The straightedge can be removed as soon as stereoscopic vision is obtained. The straightedge method is not strictly applicable to a mirror stereoscope if the mirrors are not oriented exactly. A method for a fine orientation of two photographs where the azimuth lines are not drawn is to rotate the right photograph about its own center until the images at the center of the left photograph are in stereoscopic coincidence and then to rotate the left photograph about its center until images at the center of the right photograph are in coincidence. Repeat if necessary.

It is often necessary to view two photographs with a relatively small mirror or prism stereoscope where the photographs must overlap each other and where the stereoscope must rest on the photographs. This is particularly true in field work where enlarged single-lens

photographs, or trimmed nine-lens photographs, are used. Under these circumstances it is particularly difficult for the beginner to orient the photographs for viewing, and it sometimes causes serious discomfort and eyestrain to orient them while looking through the stereoscope. A recommended procedure under such conditions is first to orient the photographs before viewing them, and then to place the stereoscope over them in position as follows:

1 Locate the positions of the conjugate centers by direct comparison of the photographic images near the centers, mark the centers, and draw the azimuth lines between them lightly with a pencil. Any definite images within a half-inch of the principal points are entirely satisfactory for this purpose.

2 Pin the left photograph to the viewing table with a thumbtack at the center, and rotate the photograph until the azimuth line is aligned parallel to the desired orientation of the stereoscope, with the conjugate center on the right. Presumably, the azimuth line will usually be aligned parallel to the near edge of the table.

3 Place the center of the right photograph on the azimuth line and separate the two photographs a fixed distance that has been determined previously, or until the separation of any pair of conjugate images is equal to the separation of the objectives of the stereoscope (or of the centers of the large mirrors if a mirror stereoscope is used). If one is using a specific stereoscope for the first time, the distance can be adjusted by trial for comfortably viewing a pair of small photographs (if they are available) and this distance can be measured and recorded for future reference, and used for setting the separation of the photographs.

4 Pin the right photograph to the table with a thumbtack at its center and rotate the photograph into its approximate orientation.

5 Place a straightedge across the centers of the two photographs and rotate either or both until the azimuth lines are exactly on the same straight line. Put paper weights on the edges of the photographs to hold them flat, and remove the straightedge.

6 Place the stereoscope on the photographs with its eye base parallel to the azimuth line, and view the model. The edge of one photograph must be rolled up to examine the part of the model where the photographs overlap. One end of the stereoscope can usually be adjusted to remove any *y*-parallax or error of alignment without moving either photograph.

If the photographs are of equal scale and without tilt, the observer can examine any part of the area of overlap without difficulty. Inasmuch as the photographs are usually tilted a small amount, the images near the edges of the overlap area tend to have *y*-parallax and appear confused. One of the photographs should then be shifted perpendicular to the flight line to remove the *y*-parallax and cause image coincidence in local areas of the overlap. The constant presence of *y*-parallax contributes to eye fatigue and to the lack of appreciation of the smaller differences in elevation. Dizziness is also sometimes caused by failure to remove *y*-parallax completely.

It is perhaps obvious in step 2 that the two photographs can be oriented as a unit in a stereoscope in two ways differing by  $180^\circ$ . The particular orientation is usually determined by one or both of the facts that (a) one wishes to write or draw lines on one of the photographs, which accordingly should be placed to the right of the observer, and (b) shadows in the photographs should fall toward the observer for a more realistic stereoscopic model.

The mirror type of stereoscope is perhaps the easiest one to use, and therefore the best one for a beginner to practice on because the photographs can be completely separated and weighted down, and there are no moving parts. Optical divergence can be practiced after coincidence has been obtained by slowly separating the photographs while viewing them stereoscopically. The simple lens stereoscope is somewhat more difficult to use because the photographs must always be overlapped and held in position while being viewed, in addition to the facts that the lenses should be placed at a convenient viewing distance from the photographs and also separated a convenient distance.

All the overlap area of two aerial photographs cannot be viewed at one time with a simple lens stereoscope because the photographs must be overlapped somewhat. A large part

of the remaining area can be seen by placing the other photograph on top. Even then it is not always possible to see a strip in the center of the overlap area, whence the edge of the top photograph must be curled upward with one hand to remove it from obstructing the view of the picture underneath. In viewing enlarged or nine-lens photographs with any stereoscope other than the large office mirror and prism types, it is almost always necessary to curl up one side of one of the photographs.

It is not uncommon for a beginner to experience a headache from using a stereoscope. This is usually a temporary condition that is not serious although a night's rest may be required to remove it. The probable explanation is that certain eye muscles are used an unaccustomed amount in a comparatively short time. Stereoscopic viewing is not harmful to the eyes, in many instances it is regarded as beneficial exercise. The ability to use a stereoscope to fullest advantage is usually developed only by intensive practice. Stereoscopic viewing of aerial photographs is a skill which, like many others, may be extremely difficult to acquire at first, but which becomes almost automatic and simple with repeated practice.

To view two photographs stereoscopically without a stereoscope is a feat that can usually be cultivated although it is very difficult or impossible for some individuals to

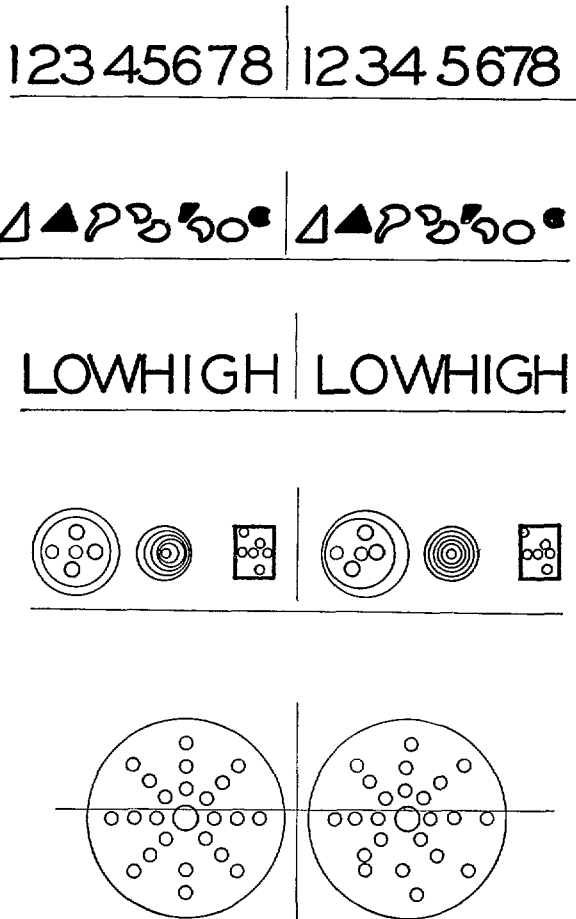

FIGURE 3 24—Stereograms



FIGURE 3 25 —Stereogram made from a pair of aerial photographs

perform It is seldom necessary for one in the Coast and Geodetic Survey to develop this skill It is almost impossible to view enlarged or nine-lens photographs without a stereoscope, and at least a pocket-type stereoscope is available to use with single-lens photographs However, the direct viewing of prepared diagrams is excellent practice for beginners who wish to develop greater flexibility and ease in the use of the stereoscope

In viewing a pair of photographs without a stereoscope one must interrupt the usual relation between the convergence and accommodation characteristics of the eyes, because where the eyes ordinarily converge on the same point in reading, here they must diverge so that each eye sees a different one of two images separated 2 inches or more One can usually train himself with stereograms (line drawings constructed as stereoscopic pairs) several of which are shown in figures 3 24, 3 25, and 3 27 Copies of these figures will be furnished by the Washington Office on request, and the stereograms can be cut in two for training purposes The training is probably somewhat easier if the stereogram consists of a single contrasting figure, and it is helpful if an azimuth line appears for orienting purposes It is usually easier at first to view the stereograms at arm's length and separated only about an inch If the images do not appear as a single image, look at some object across the room or out of the window, looking over the top of the stereograms, and then lower the eyes to the figures After several trials at most, the stereograms should appear as a single diagram Actually three images may be seen, of which the center one is the desired stereoscopic image and the others are extraneous If the diagrams can be seen stereoscopically at arm's length, then the diagrams can be brought slowly closer to the eyes and also slowly separated a greater distance After some practice it should become possible to view the stereograms immediately at a distance of 10 inches and separated 2 inches or more, and to substitute aerial photographs for the stereograms Spectacles of short focal length can sometimes be used satisfactorily by those who find it extremely difficult to view the photographs without any aid Dime-store spectacles of two, three, or four diopters can be used at a 10-inch viewing distance to enable the eyes to diverge quite naturally, but it is usually not comfortable to wear the glasses to look at anything else

### 335 THE FLOATING MARK

A stereoscopic plotting instrument is equipped with a floating mark, also referred to as floating dot or wandering mark It is used both as an index mark, or tracing mark, and also as a device for measuring the apparent heights of images in the stereoscopic model The shape of the mark is often that of a very small round black dot, but marks shaped like a "V", "T", a luminous dot formed by a light source beneath a pinhole aperture as in the multiplex, or a grid over the entire overlap area are also used The floating mark is usually composed of two targets, one for each eye The targets are often etched on pieces of glass and either placed in contact with the photographs as  $n$  and  $n'$  in figures 3 14 and 3 26, or located as reticles somewhere else in an optical system so that they *seem* to be in contact with the photographs The mind responds to the marks in much the same manner as it does to other points and lines in the figure, interpreting them as a single mark in space in the stereoscopic model

It is evident that if  $n$  in figure 3 26 is moved closer to  $n'$  in the direction parallel to the eye base  $OO'$ , such as are  $r$  and  $r'$ , then the apparent position in space will move upward with respect to the rest of the model Thus, the horizontal displacement of  $n$  with respect to  $n'$  parallel to the eye base or flight line can be used as a measure of height or depth It

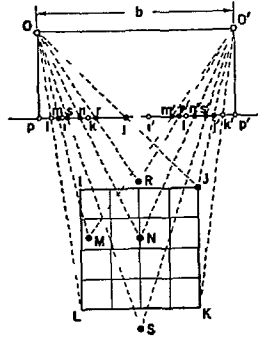

FIGURE 3 26 —The principle of the “floating mark”

is obvious that this displacement is identical to parallax difference as discussed in 3264 where the relation to ground elevation is demonstrated

It is noteworthy that if  $n$  and  $n'$  are not on a line parallel to the eye base, the lines  $On$  and  $O'n'$  fail to intersect at any common point in space. Thus, in stereoscopic viewing, the dots appear as two distinct dots, or else a dot of confusion, indicating a separation in a direction perpendicular to the eye base. This is commonly referred to as  $y$ -parallax because it appears to occur also when the *images* are separated in the  $y$ -direction even though the dots are not

The floating marks can, of course, be moved about the photographs horizontally as a pair, such as  $m$  and  $m'$  of figure 3 26 without appearing to change the elevation of  $M$ , provided the line joining the points is parallel to the eye base. If the left mark is placed in coincidence with the image  $j$ , and the right mark is placed in coincidence with the image  $j'$ , then it is obvious that the object mark will also appear to be in coincidence with the object  $J$  in the model. Thus, the floating marks can be moved about as a pair on the photograph to coincide with image points and appear to move horizontally from point to point in the model. Then, with the added ability to change the separation of the marks on the photographs, the mental impression of the fused mark is that of a pointer moving freely in the three dimensions of the stereoscopic space model. A stereoscopic plotting instrument is a result of the application of the principle of the floating mark wherein the mark can be regarded as a “pointer” which is used to trace out planimetric detail and to measure differences in elevation

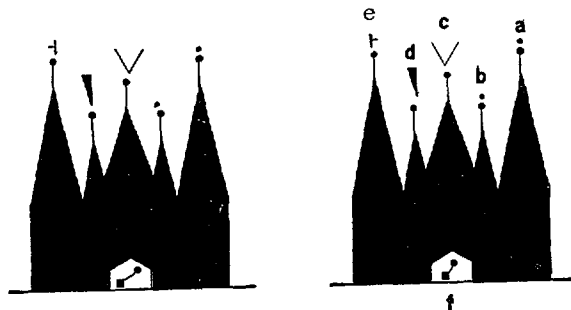

FIGURE 3 27 —Stereogram showing “floating marks”

In figure 3 27 is shown a stereogram in which the floating mark  $a$  appears to lie in the plane of the figure, marks  $b$  and  $d$  appear to be to the rear of the figure, marks  $c$  and  $e$  appear

to be in front of the figure, the rectangular part of mark  $f$  is in the rear whereas the round portion is in front. It is to be noted that the only differences in the respective marks that result in depth differences are the relative separations of each pair. For example, because the pair of marks at  $b$  are farther apart than the pair of marks at  $a$ , then  $b$  appears to be farther away.

### 34 THE NEAR-VERTICAL PHOTOGRAPH

A near-vertical photograph is one that is taken with the camera axis nearly vertical but not exactly vertical—one that was intended to be truly vertical but was not quite vertical because of unavoidable circumstances. The term distinguishes between a photograph that is only slightly tilted and an oblique photograph which is purposely tilted a comparatively large amount. A near-vertical photograph is generally tilted less than  $5^\circ$  but there is no sharp line of demarcation. Oblique photographs are discussed separately in **37** although many of the principles of this section apply to obliques as well as to near-verticals.

The uneven characteristics of the atmosphere (winds, air pockets, etc.) are the underlying causes of tilted photographs because the aircraft is prevented from proceeding in straight level flight by the constantly changing atmospheric conditions. The fluid in the level vials of an aerial camera is affected by inertia forces created by slight changes in the direction of flight. Thus there is no exact indication available for determining horizontal and vertical directions for leveling an aerial camera. Also, ordinary human error prevents the photographer from holding the camera exactly vertical for each exposure. Special navigating devices together with an experienced and cooperative photographic crew tend to reduce the degree of tilt. No practicable device has yet been perfected for either the complete removal or an accurate indication of the tilt of an aerial photograph, although the problem has been solved in special instances by using auxiliary horizon cameras. Domestic photographs for mapping are often required to have less than  $3^\circ$  of tilt. Usually about 90 percent of all mapping photographs are tilted less than  $2^\circ$ , and 50 percent are tilted less than  $1^\circ$ . About 75 percent of the nine-lens photographs are tilted less than  $1^\circ$ .

The purpose of this section is to consider the effects of tilt on aerial photographs and the principles applicable to making maps from near-vertical photographs. It is shown in **32** that horizontal positions and elevations can be obtained from the images on truly vertical photographs by means of relatively simple procedures. The theoretical principles of this section form a basis for altering the procedures of mapping from vertical photographs so that acceptable maps can also be obtained from near-verticals.

#### 341 DEFINITIONS AND NOMENCLATURE

The geometric center  $p$  (see fig. 328) of a photograph is called the *principal point*. It is usually indicated either by a mark at the center of a photograph or by *fiducial marks* at the edges, which marks can be connected by lines that intersect at the principal point. The *photograph perpendicular*  $pO$  is a line perpendicular to the plane of the photograph at the principal point. The photograph perpendicular coincides with the lens axis. The *ground principal point*  $P$  is the point where the photograph perpendicular intersects the ground. The *perspective center*  $O$  lies on the photograph perpendicular a distance  $f$  from the principal point. The distance  $f$  is known both as the *focal length* and as the *principal distance* of the photograph. The use of the term principal distance implies that the distance  $Op$  is a value different from the focal length of the aerial camera, a value altered by ratio printing or by the shrinkage of photographic materials. The symbol  $f$  is used to represent the quantity in

either case It is helpful to regard each photograph as having definitely associated with it a photograph perpendicular, a focal length, and a perspective center

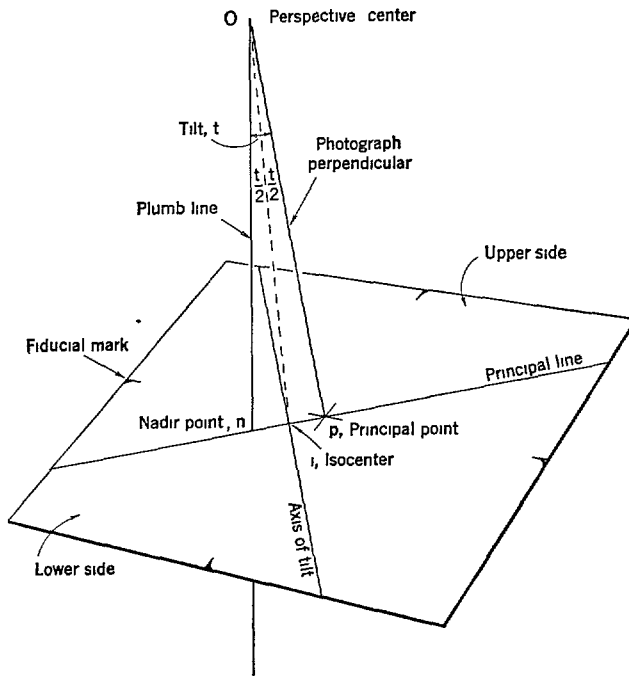

FIGURE 3 28 —Nomenclature of the near vertical photograph

The *plumb line* is a truly vertical line that passes through the perspective center  $O$  The point  $n$  where the plumb line intersects the plane of the photograph is called the *nadir point* The *ground nadir point*  $N$  is the point where the plumb line intersects the ground The *principal line* is the line  $pn$  extended, on the photograph that passes through the principal point and the nadir point It may help to think of the principal line as the path along which a marble would roll on being released at the principal point The plane  $npO$  formed by the photograph perpendicular and the plumb line is the *principal plane* Obviously, the principal plane is a vertical plane The principal line can be defined also as the intersection of the principal plane and the plane of the photograph The tilt  $t$  of the photograph is the angle  $pOn$  measured at the perspective center between the photograph perpendicular and the plumb line The tilt angle can also be defined as the dihedral angle  $wvw'$  (see fig 3 29) between the plane of the photograph and a horizontal plane (It is to be noted that tilt is here considered only as the resultant or total tilt, with no reference to such component tilt angles as  $t_{ip}$ ,  $t_{ln}$ , etc ) If the tilt  $t$  is zero, then the nadir and principal points coincide and the photograph perpendicular coincides with the plumb line

An *equivalent vertical photograph* (see fig 3 29) is a vertical photograph that has the same perspective center and focal length as a specific tilted photograph The line of intersection of the tilted photograph plane and the equivalent vertical photograph plane is the *axis of tilt* The *isocenter*  $i$  is the point of intersection of the principal line and the axis of tilt The *ground isocenter* is the point where the line  $O_i$  connecting the perspective center and the isocenter intersects the ground



The upper side of a photograph is the raised side of a tilted contact print. The axis of tilt is customarily regarded as the dividing line between the upper and lower sides, although in 346 it is more convenient to regard the horizontal line through the nadir point as the dividing line.

342. SOME GEOMETRIC PRINCIPLES

A few geometric principles are derived in somewhat the same manner as theorems in plane geometry.

3421 *The Isocenter Line Bisects the Tilt Angle*

The tilt angle  $t$  at the perspective center is bisected by the line to the isocenter. In figure 3 29, the line  $O_i$  bisects the angle  $pOn'$  or angles  $n'O_i$  and  $pO_i$  are equal.

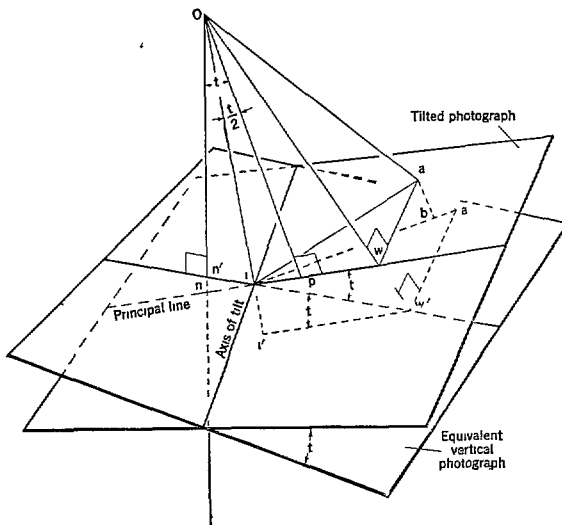

FIGURE 3 29—Geometry of the near vertical photograph

The customary nomenclature is observed in the figure with  $n'$  being the intersection of the plumb line with the equivalent vertical photograph. Then  $n'$  is the principal point of the equivalent vertical photograph whose focal length is  $On' = Op = f$  by definition. Consider the two triangles  $On'i$  and  $Op_i$ . They are right triangles because  $Op$  is the photograph perpendicular of the tilted photograph, and  $On'$  is the photograph perpendicular of the equivalent vertical. Inasmuch as the sides  $O_i$  of the triangles are identical, then the two triangles are congruent because two sides and one angle are respectively equal. Consequently, angles  $n'O_i = pO_i = \frac{t}{2}$ .

3422 *Distances to the Nadir Point and Isocenter*

The distance from the principal point to the nadir point is equal to the focal length multiplied by the tangent of the angle of tilt. The distance from the principal point to

the isocenter is equal to the focal length multiplied by the tangent of half the angle of tilt. The statements are expressed algebraically as

$$pn = f \tan t \quad (3422A)$$

$$pi = f \tan \frac{t}{2} \quad (3422B)$$

In figure 329, triangle  $Opn$  is a right triangle with the right angle at  $p$ . By trigonometry,

$$\tan t = \frac{pn}{Op} = \frac{pn}{f}$$

from which equation 3422A is obtained by rearranging the terms. Similarly, equation 3422B is obtained from the right triangle  $Op_i$ .

It should be noted that for many practical uses of near vertical photographs  $pi$  can be regarded as one-half of  $pn$ . Also,

$$pn \approx f \sin t$$

because the sine and tangent functions are nearly equal for small angles. These approximations are not valid where the tilt angle is larger than about  $5^\circ$  and therefore should not be used with oblique photographs, nor for research work on near verticals.

A few other facts are of interest. In right triangle  $Opn$ ,

$$On = \frac{f}{\cos t} = f \sec t \quad (3422C)$$

In the right triangle  $On'i$ , the right angle is at  $n'$ , and

$$n'i = f \tan \frac{t}{2}.$$

In the right triangle  $nn'i$ , the right angle is at  $n'$ , angle  $nn'i = t$ , and

$$\cos t = \frac{n'i}{ni}$$

$$ni = \frac{n'i}{\cos t} = f \tan \frac{t}{2} \sec t$$

*Example 1* If the calibrated focal length of an aerial camera is 800 inches and the tilt is  $5^\circ$ , what are the distances from the principal point to the nadir point and to the isocenter?

*Solution*

$$\begin{aligned} pn &= 800 \tan 5^\circ = 800 \times 0.0875 = 0.700 \text{ inches} \\ pi &= 800 \tan 2^\circ 30' = 800 \times 0.0437 = 0.350 \text{ inches} \end{aligned}$$

(Note that  $pi$  is half of  $pn$ . Also if the sine values 0.0872 and 0.0436 are used in place of the tangents, the results are not changed materially.)

*Example 2* An oblique photograph has a focal length of 150.0 mm and a tilt of  $60^\circ$ . Find the distances from the principal point to the nadir point and to the isocenter.

*Solution*

$$\begin{aligned} pn &= 150.0 \tan 60^\circ = 150.0 \times 1.732 = 259.8 \text{ mm} \\ pi &= 150.0 \tan 30^\circ = 150.0 \times 0.5774 = 86.61 \text{ mm} \end{aligned}$$

(Note that the approximations referred to in *example 1* are far from being correct in *example 2*.)

3423 *Horizontal Angles Exist at the Isocenter*

The angle subtended at the isocenter by any two images is equal to the horizontal angle subtended at the ground isocenter by the corresponding two objects if the ground isocenter and the two objects are all at the same elevation

An equivalent vertical photograph of flat terrain is identical to a map, and all angles on that photograph are equal to the corresponding ground horizontal angles. Therefore, it is valid to consider the equivalent vertical photograph instead of the ground in proving the theorem. In figure 3 29 let  $a$  be any image on the tilted photograph whose principal point is  $p$ , perspective center is  $O$ , and whose isocenter is at  $i$ . Let  $w$  be the orthogonal projection of  $a$  on the principal line so that  $aw$  is perpendicular to  $wi$ . Let  $a'$  and  $w'$  be the positions of the images of the same two objects  $A$  and  $W$  (not shown) on the equivalent vertical photograph. In other words,  $a'$  is on the line  $Oa$  extended, and  $w'$  is on the line  $ow$  extended. It is to be shown that angles  $aww$  and  $a'w'w'$  are equal.

The lines  $aw$  and  $a'w'$  are parallel because they lie in the common plane  $Oa'w'$  which is parallel to the line of intersection (axis of tilt) of the two photograph planes. Triangles  $Owa$  and  $Ow'a'$  are similar because their sides are respectively parallel. Then the sides are proportional, or

$$\frac{wa}{w'a'} = \frac{Ow}{Ow'} \tag{3423A}$$

Construct the line  $w'i'$  parallel to  $wi$  and let  $i'$  be the intersection of  $w'i'$  with  $Oi$  extended. Then the triangles  $Owi$  and  $Ow'i'$  are also similar and

$$\frac{wi}{w'i'} = \frac{Ow}{Ow'} \tag{3423B}$$

By equating the left sides of equations 3423A and B,

$$\frac{wa}{w'a'} = \frac{wi}{w'i'} \tag{3423C}$$

But  $w'i' = w'i$  because (1) angle  $w'i'w' = w'iw' = t$ , inasmuch as  $wi$  and  $w'i'$  are parallel, (2) angle  $w'i'O = w'iO$  for the same reason, (3) in the right triangle  $Opi$ ,

$$\text{angle } piO = 90^\circ - \frac{t}{2} = w'iO = w'i'i ,$$

(4) in triangle  $w'i'i$ ,

$$\text{angle } w'i'i = 180^\circ - t (90^\circ - \frac{t}{2}) = 90^\circ - \frac{t}{2} = w'i'i ,$$

then (5) the triangle  $w'i'i$  is isosceles and the two sides are equal that are opposite the two equal angles. Substituting  $w'i$  for  $w'i'$  in equation 3423C and rearranging the proportion algebraically

$$\frac{wa}{wi} = \frac{w'a'}{w'i}$$

In the right triangle  $aww$ ,  $\tan aww = \frac{wa}{wi}$ . Similarly,  $\tan a'w'w' = \frac{w'a'}{w'i}$ , or

$$\tan aww = \tan a'w'w'$$

and two angles are equal

The proof is not a general one because the second image  $w$  was assumed to lie on the principal line. However, the angle between any two images can be regarded as the sum or the difference of the two angles between the image lines and the principal line. Inasmuch as these principal angles are equal to corresponding horizontal angles, then their sums or differences are also equal, and the proof is valid in any instance.

### 3424 The Inclination of any Line

The inclination  $t'$  of any line on a photograph relative to the horizontal can be determined by means of the expression

$$\sin t' = \sin t \cos \theta \quad (3424A)$$

where  $t$  is the tilt of the photograph and  $\theta$  is the acute angle in the plane of the photograph between the given line and the principal line.

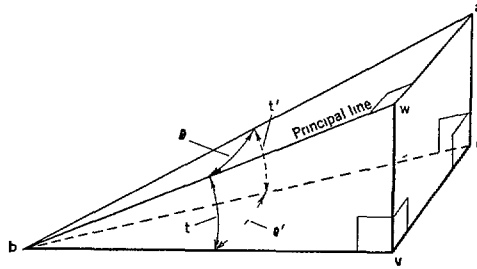

FIGURE 330.—The inclination of any line

Figure 330 shows a part of a tilted photograph  $abvw$  whose principal plane is  $bvw$  and whose tilt is the angle  $wbv = t$ . The plane  $bcw$  is a horizontal plane. Point  $a$  is any point on any line such as  $ab$  on the tilted photograph, and  $b$  is the point of intersection of the line  $ab$  and the principal line. The point  $c$  is the orthogonal projection of  $a$  on the horizontal plane,  $w$  is the orthogonal projection of  $a$  on the vertical principal plane, and  $v$  is the orthogonal projection of  $w$  on the horizontal plane. Then planes  $abc$  and  $acvw$  are vertical planes. The angle  $t' = abc$  is the inclination of the line  $ab$  with the horizontal and the angle  $\theta$  is the acute angle formed in the plane of the photograph by the intersection of the line  $ab$  and the principal line  $bw$ . By plane trigonometry, in the right triangle  $acb$ ,

$$\sin t' = \frac{ac}{ab}. \quad (3424a)$$

In the right triangle  $bvw$ ,

$$\sin t = \frac{vw}{bw}.$$

Owing to the fact that  $vw = ac$  by construction,

$$\sin t = \frac{ac}{bw}.$$

$$ac = bw \sin t$$

In right triangle  $awb$ ,

$$\cos \theta = \frac{bw}{ab}.$$

$$ab = \frac{bw}{\cos \theta}.$$

By substitution for  $ac$  and  $ab$  in equation 3424a,

$$\sin t' = \frac{bw \sin t}{\frac{bw}{\cos \theta}} = \sin t \cos \theta \quad (3424A)$$

It is of interest to note that if angle  $cbv = \theta$  in the horizontal plane ( $\theta'$  is also the horizontal and dihedral angle between the two vertical planes  $bvw$  and  $abc$ ), then it can be shown in a similar manner that

$$\tan t' = \tan t \cos \theta' \quad (3424B)$$

$$\tan \theta = \tan \theta' \cos t \quad (3424C)$$

Obviously, equations 3424A, B, and C could have been derived by the use of principles of spherical trigonometry in a somewhat more direct manner

In equation 3424A if the angle  $\theta$  is zero, then the inclination is simply  $t$  which leads to the generalization that on a photograph every line that is parallel to the principal line has the same inclination  $t$  as the principal line. If  $\theta$  is  $90^\circ$ , then the inclination is zero, and it can be said that every line that is perpendicular to the principal line, or parallel to the axis of tilt, is a truly horizontal line. Also, all lines that intersect the principal line at equal angles  $\theta$  are parallel and have the equal inclinations  $t'$ . It should be noted that any line that passes through the nadir point of a photograph can be considered as the principal line of a photograph having a tilt  $t'$ , so far as images on that line are concerned.

*Example 1* What is the inclination of a line through the isocenter that makes an angle of  $40^\circ$  with the principal line of a photograph tilted  $2^\circ$ ?

Solution

$$\sin t' = \sin 2^\circ \cos 40^\circ = 0.03490 \times 0.76604 = 0.02673$$

$$t' = 1^\circ 32'$$

*Example 2* A rectifying camera shows that the horizontal angle between the principal plane and a radial line through one of the fiducial marks is  $57^\circ$ . What is the corresponding angle in the plane of the photograph if the photograph principal line was tilted at an angle of  $5^\circ$ ?

Solution Angle  $\theta'$  is given and  $\theta$  is required. From equation 3424C,

$$\tan \theta = \tan \theta' \cos t$$

$$= \tan 57^\circ \cos 5^\circ = 1.5399 \times 0.99619 = 1.5340$$

$$= 56^\circ 54'$$

Computations involving equations like 3424A are frequently used in an approximate manner to simplify the procedure with little or no loss of accuracy where the values of  $t$  or  $t'$  are small. This is done by using the value of the angle in minutes rather than the tangent or sine function, because in small angles these functions change at a rate that is very nearly proportional to the angle itself. The error involved is usually less than 1 minute if the tilt angle is less than  $5^\circ$ . The approximate equation is then identical for 3424A and B

$$t' \approx t \cos \theta \quad (3424D)$$

*Example 3* Solve *example 1* using the approximate formula

Solution

$$t' = 2^\circ \times \cos 40^\circ$$

$$= 120 \text{ minutes} \times 0.76604 = 91.9 \text{ minutes}$$

$$\text{or } 1^\circ 32' \text{ to the nearest minute}$$

## 343 TILT DISPLACEMENT

Tilt displacement is the linear difference in the position of an image on a tilted photograph relative to the corresponding position on the equivalent vertical photograph. In figure 3 29 the tilt displacement  $d_t$  of any image  $a$  due to the tilt  $t$  is defined as

$$d_t = ia' - ia$$

The algebraic sign of  $d_t$  is always considered as positive

## 3431 Direction of Tilt Displacement

The displacement of any image due to tilt occurs along the line that passes through the image and the isocenter. Accordingly, it is often stated that tilt displacement is radial from the isocenter.

In figure 3 29, consider that the tilted photograph is rotated about its axis of tilt so that the tilted plane lies in the plane of the equivalent vertical photograph. The line  $ia$  will lie on the line  $ia'$  because angles  $awv$  and  $a'vw'$  are equal (3432). Then the points  $a$ ,  $a'$ , and  $i$  will all lie on the same straight line and the displacement  $d_t = ia' - ia = ba'$  will be a segment of this line.

The figure illustrates an image on the *upper* side of the photograph where the image  $a$  on the tilted photograph appears closer to the isocenter than does  $a'$  on the equivalent vertical photograph. Accordingly, an image on the upper side of a tilted photograph is said to be displaced *inward* toward the isocenter. It is also evident that any image that lies on the *lower* side of the tilted photograph is displaced *outward* from the isocenter. The direction of tilt displacement is independent of the elevation of the object because tilt displacement is defined relative to the image position on the equivalent vertical photograph, which image may or may not have been subject to previous relief displacement.

## 3432 Amount of Tilt Displacement

The amount of tilt displacement  $d_t$  can be expressed as

$$d_t = \frac{r^2}{\frac{f}{\sin t} - r} \quad (3432A)$$

where  $r$  is the radial distance from the isocenter to an image on a tilted photograph considered as positive on the upper side and negative on the lower side,  $f$  is the focal length of the camera or the principal distance, and  $t$  is the angle of tilt.

In figure 3 31  $a$  is an image on the principal line, and the distance  $ia$  is represented by the symbol  $+i$ . The point  $b$  is located on the line  $ia'$  such that  $ib = ia$ , and the line  $ab$  is drawn through  $a$  and  $b$ . By the definition of tilt displacement of 343,  $d_t = ba'$ . Then triangle  $abv$  is isosceles by construction and the angles  $abv$  and  $bav$  are equal. The angle  $abv$  is equal to the tilt  $t$  of the photograph by definition, whence

$$\text{angle } abv = \text{angle } bav = 90^\circ - \frac{t}{2}$$

It is shown in 3423 that angle  $pvO$  is also equal to  $(90^\circ - t/2)$ , which is angle  $avO$  in figure 3 31. Then  $ab$  and  $Ov$  are parallel because the opposite interior angles  $bav$  and  $avO$  are equal. However,  $a'b$  is also parallel to  $a'v$ , and  $aa'$  is parallel to  $Oa'$  because the respective lines are common lines, or are collinear. Therefore, triangles  $aba'$  and  $Oia'$  are

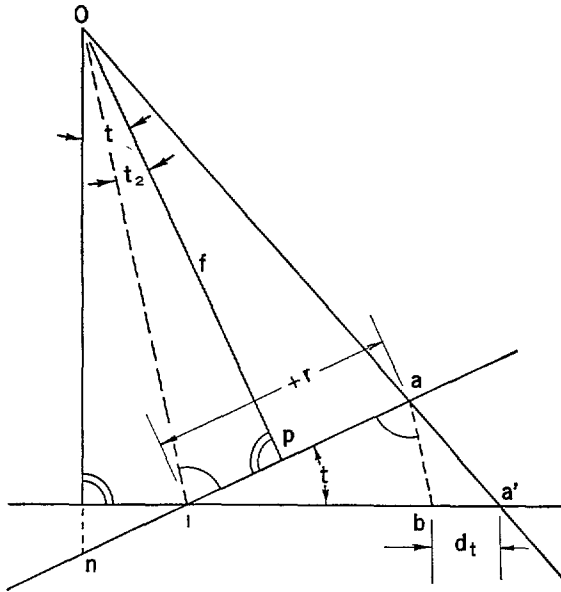

FIGURE 3 31—The amount of tilt displacement

similar and the following relations between the ratios of their corresponding sides can be expressed

$$\frac{ba'}{ia'} = \frac{ab}{O_i} \tag{3432a}$$

From figure 3 31,

$$ia' = ib + ba' = r + d_t$$

In the right triangle  $O_i p_i$ , it is evident from trigonometry that

$$O_i = f \sec t/2$$

Also it can be shown by plane trigonometry that in the isosceles triangle  $aub$ ,

$$ab = 2 r \sin t/2$$

Then by substitution in equation 3432a,

$$\frac{d_t}{r + d_t} = \frac{2 r \sin \frac{t}{2}}{f \sec \frac{t}{2}}$$

$$d_t = \frac{r(r + d_t) 2 \sin \frac{t}{2} \cos \frac{t}{2}}{f}$$

Inasmuch as in plane trigonometry  $\sin X = 2 \sin \frac{X}{2} \cos \frac{X}{2}$  for any angle  $X$ ,

$$d_t = r (r + d_t) \frac{\sin t}{f}.$$

The solution of this equation by algebra for  $d_t$  yields equation 3432A. The solution for  $\sin t$  yields

$$\sin t = \frac{fd_t}{r(r + d_t)}. \quad (3432B)$$

It can be shown that the solution for the displacement of an image on the lower side of a photograph results in relations identical to equations 3432A and B where  $+r$  is replaced by  $-r$ .

The equations are frequently simplified for practical approximations to the forms

$$d_t \approx \frac{r^2 \sin t}{f} \quad (3432C)$$

$$\sin t \approx \frac{fd_t}{r^2} \quad (3432D)$$

because  $d_t$  is usually so small relative to  $r$  that  $d_t$  can be ignored in  $(r + d_t)$  without seriously affecting the results. In the two latter equations, the displacements on the upper and lower sides are regarded as being equal, which is not quite true. Obviously, the algebraic sign of  $r$  is of no consequence in 3432C and D. (See also fig. 47.)

It is of interest to note that tilt displacement varies approximately as the square of the radial distance on a tilted photograph (equation 3432C) whereas relief displacement varies as the first power of the radial distance on an untilted photograph (equation 3232A). Equations 3432B and D furnish a means for tilt determination based on the value of  $d_t$  of an image. Although the equations express the radial displacement for images on the principal line, the equations are also valid for any image on the photograph if the inclination  $t'$  (3424) of the line from  $i$  to the image is used in place of  $t$ .

*Example 1* Compute the displacement due to a tilt of  $3^\circ$  for an image on the principal line 4 inches from the axis of tilt on the upper side of a photograph whose focal length is 6 inches.

*Solution* Using equation 3432A,

$$d_t = \frac{4 \times 4}{\frac{6}{\sin 3^\circ} - 4} = 0.1446 \text{ inch}$$

*Example 2* Solve *example 1* using the simplified equation.

*Solution*

$$d_t = 4 \times 4 \times 0.05234 - 6 = 0.1396 \text{ inch}$$

*Example 3* What is the displacement of an image on the lower side of a nine-lens photograph if the image is on the principal line, the focal length is 200 mm, the tilt is  $2^\circ$ , and the radial distance is 350 mm?

*Solution*

$$d_t = \frac{(-350)(-350)}{(200 - 0.03490) - (-350)} = 20.15 \text{ mm}$$

(The approximate equation gives 21.38 mm.)

*Example 4* Solve *example 3* if the radial line makes an angle of  $40^\circ$  with the principal line.

*Solution* From equation 3324A,

$$\sin t' = \sin 2^\circ \cos 40^\circ = 0.03490 \times 0.76604 = 0.02673$$

$$d_t = \frac{(-350)(-350)}{(200 - 0.02673) - (-350)} = 15.64 \text{ mm}$$

*Example 5* The tilt displacement for the image on the upper side of a nine-lens photograph is found by measurement to be 25.2 mm. The distance from the isocenter to the image is 319 mm and



the angle between the radial line and the principal line is  $17^\circ$ . Find the tilt of the photograph if the focal length is 210 mm.

Solution. The inclination of the radial line can be found by equation 3432B

$$\sin t' = \frac{210 \times 25.2}{319(319 + 25.2)} = 0.0482$$

Because  $\sin t' = \sin t \cos \theta$ , by equation 3424A,

$$\sin t = \sin t' - \cos \theta$$

$$\sin t = \sin t' - \cos 17^\circ = 0.0482 - 0.956 = 0.0504$$

$$t = 2^\circ 53'$$

### 3433 Direction of Relief Displacement on a Tilted Photograph

The extension of the line-image of a vertical line-object passes through the nadir point. It is frequently expressed that relief displacement is always radial from the nadir point.

In figure 36, the extension of the line  $aa'$  of the object line  $AA'$  passes through  $p$ , the principal point of the vertical photograph. If the photograph is tilted in any manner, the nadir point  $n$  replaces  $p$  and lies on the vertical line  $OP$  or  $ON$ . The line  $A'O$  lies in the vertical plane  $OnPA'A$  and hence the point  $a'$  does also. The line  $aa'n$  is a continuous straight line because it is the intersection of the vertical plane and the inclined plane of the photograph. The initial statement is then proved.

Thus, tall straight objects, such as the vertical edges of buildings and the centerlines of stacks, project images on a photograph all of which appear to radiate from the nadir point regardless of the amount of tilt. This principle might be used as a method for tilt determination in certain special cases.

### 3434 Tilt and Relief Displacements Combined

There is no common point on a photograph from which all images are displaced radially from their equivalent map positions if there is a combination of tilt and relief. Although correct horizontal angles are subtended at the principal point if there is no tilt, and at the isocenter of a tilted photograph if there is no relief, no such central point exists if there is both tilt and relief.

A part of a tilted photograph is shown in figure 332 where  $a$  and  $b$  are the images of the bottom and top of an elevated object. The line  $ab$ , extended, passes through the nadir point  $n$  as explained in 3433. Let the equivalent vertical photograph be superposed on the tilted one so that the common isocenter and axis of tilt coincide. Then  $n'$  represents the position of the principal point and the nadir point of the equivalent vertical photograph and the relation of  $n$  and  $n'$  is identical to that shown in figure 329. The distance  $m'$  is always less than  $m$  but the difference is exaggerated in figure 332—for a near-vertical photograph  $m'$  and  $m$  are practically equal. The images  $a'$  and  $b'$  represent the bottom and top of the same object as  $a$  and  $b$ , respectively. The line  $a'b'$ , extended, also passes through its nadir point  $n'$ .

The point  $a'$  is the correct map position for both the top and bottom of the object and is therefore also the correct map position for the image  $b$  of the tilted photograph. The image  $b$  accordingly can be subjected to two component displacements to bring it to its map position  $a'$ —one due to tilt from  $b$  to  $b'$  toward the isocenter a distance in accordance with 3432 and a second due to elevation from  $b'$  to  $a'$  toward the nadir point  $n'$  in accordance with 3232. The resultant displacement  $ba'$  can generally be extended to inter-

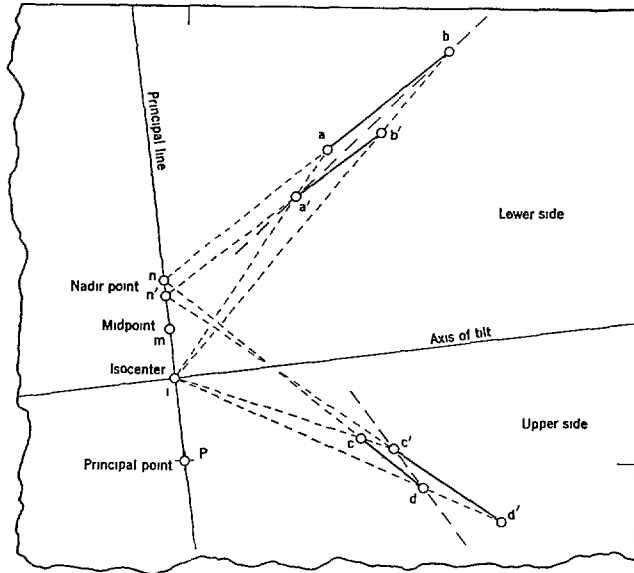

FIGURE 3 32 —Effect of tilt and relief on radial lines

sect perhaps the principal line at some point. Obviously, if  $a$  and  $b$  had been in a different part of the photograph, or if the relief displacement  $ab$  were of different amount, the line  $ba'$  would intersect the principal line at some point different than shown here. Consider in a similar manner two other images  $c$  and  $d$  on the upper side of the photograph where the tilt displacements are inward and where  $c'$  is the final map position of the elevated object and the line  $c'd$  might conceivably be parallel to the principal line. It is quite obvious that the intersection of the lines  $a'b$  and  $c'd$  would not lie on the line of displacement for any third pair of images of an elevated object. The cited facts are sufficient to verify the original statement, and no strict mathematical proof is given.

It can be shown that a point  $m$  (the midpoint) midway between the isocenter and nadir point is usually the best practical compromise for a common radial center from which to obtain most nearly correct horizontal angles from a near-vertical photograph. Because the points  $i$  and  $n$  are relatively close together, the error in assuming that the resultant line of displacement passes through the midpoint is not a serious error, for example, a line  $md$  of the figure is usually sufficiently near a line  $mc'$  as to cause little or no difficulty.

The manner of image displacement for combined tilt and relief is demonstrated in 351 and also by the following numerical example.

*Example* An image  $a_1$  appears on a photograph as shown in figure 3 33 where the focal length is 8 inches and the tilt is  $2^\circ 40'$ . The object is 1,000 feet above sea level and the flying height is 15,000 feet. Find the equivalent map position of a point at sea level vertically beneath the object.

*Solution* It is first necessary to determine the location of the image on the untilted photograph by applying the tilt displacement as a correction. The tilt displacement can be computed from equations 3432A and 3424A

$$d_t = \frac{r^2}{t \sin t'} - r = \frac{r^2}{f \sin t \cos \theta} - r$$

The distances  $pi$  and  $pn$  are computed by equations 3422A and B and  $i$  and  $n$  are located on the photograph.

The distance  $r = ia_1 = 5.11$  inches and

$$\text{angle } \theta = \rho ia_1 = 51^\circ 28'$$

are obtained from the photograph with a scale and protractor, respectively. The algebraic sign of  $r$  is plus because  $a_1$  is on the upper side of the photograph. Then

$$d_t = \frac{5.11 \times 5.11}{\frac{8}{(0.04653 \times 0.62297)} - 5.11} = 0.096 \text{ inch}$$

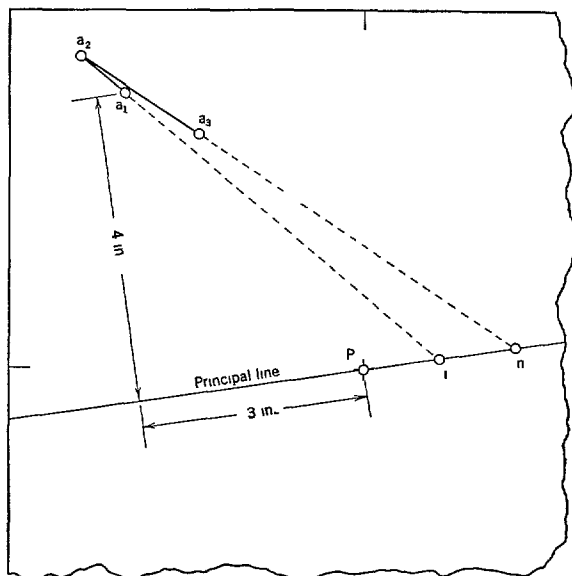

FIGURE 3.33 —Example of combined tilt and relief displacements

It is next necessary to determine the location of the image of the base of the object by applying relief displacement to the image  $a_2$  on the equivalent vertical photograph. The relief displacement can be computed from equation 3232A

$$d_o = rh/H$$

The distance  $r = na_2 = 5.33$  inches is scaled from the photograph. Then

$$d_o = 5.33 \times 1000 / 15000 = 0.355 \text{ inch}$$

Therefore the equivalent map position of the base point  $a$  is located by measuring (1) a distance 0.096 inch from the image  $a_1$  outward along the line through the isocenter, and thence (2) a distance 0.355 inch inward toward the nadir point. It should be noted that a line through the initial image  $a_1$  and the final position  $a$  does not pass through the principal point, isocenter, nadir point, or midpoint.

### 344 THE EFFECT OF TILT ON SCALE

The determination of scale by equation 3221A produces differing and erroneous values where the images are displaced because of tilt. It is noteworthy that the scale at a single

point on a photograph is expressed by equation 3222A,  $S = \frac{f}{H}$ . This discussion considers

the effect of tilt on the scale value as a basis for understanding the scale point method of tilt determination and the general effect of tilt on a photograph.

3441 *Rate of Scale Change Due to Tilt*

The rate of change in scale due to tilt is constant along any line on a photograph. For example, if, due to tilt, the scale fraction  $S = 1/20,000 = 0.00005$  changes 0.000001 for two images 1 inch apart, then everywhere along the line that joins the two images (and every line parallel to it), the scale fraction changes the same amount in a distance of 1 inch. The important idea is that the scale changes at an unvarying rate rather than at some changing rate.

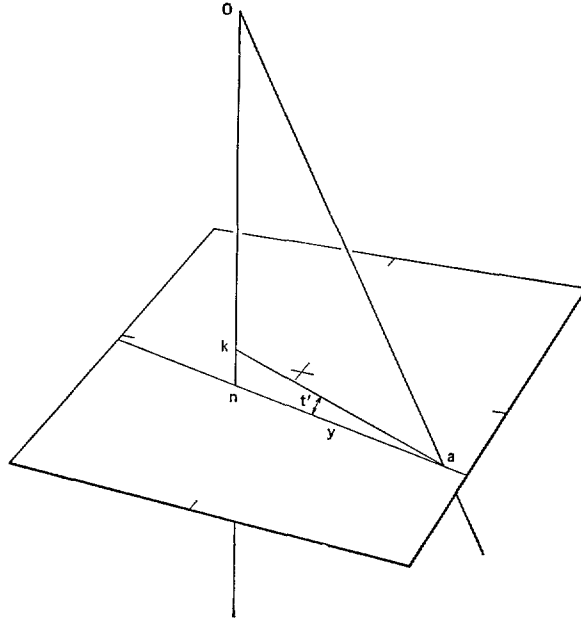

FIGURE 3.34—The scale at any image

In figure 3.34,  $a$  is any image on the upper side of the tilted photograph whose perspective center is  $O$ , nadir point is  $n$ , and whose tilt is  $t$ . Line  $na$  is a line on the photograph through the image and the nadir point. The inclination of the line  $na$  is  $t'$  as explained in 3424. Line  $ak$  is a horizontal line through  $a$  that intersects the plumb line at  $k$ . Then  $ak$  is perpendicular to  $On$  and angle  $nka$  is  $t'$ . The image  $a$  can be considered as lying also in an untilted photograph whose focal length is  $Ok$ . The scale of this vertical photograph and of the image  $a$  in particular is expressed by equation 3222B in which relief is not considered

$$S = \frac{Ok}{H}.$$

But  $Ok = On - nk$ , and in the right triangle  $nka$ ,  $nk = na \sin t'$ . Let  $f' = On$  and  $y = na$ . Then  $Ok = f' - y \sin t'$  and

$$S = \frac{f' - y \sin t'}{H} \quad (3441A)$$

$$S = \frac{f'}{H} - \frac{\sin t'}{H} y$$

In this form,  $y$  is the only term that is related to the position of the image on the photograph. On any particular photograph,  $f'$ ,  $t'$ , and  $H$  are fixed or constant quantities for all

images along the line  $na$ , whereas  $S$  and  $y$  are the only variable quantities. The rate of change in scale  $\frac{dS}{dy}$  with respect to a change in the position element  $y$  can then be derived by algebra or by differential calculus

$$\frac{dS}{dy} = \frac{-\sin t'}{H} \quad (3441B)$$

This shows that the rate of change is constant because each term on the right side is constant. The negative sign indicates that a change in the position of  $y$  in the direction  $na$  toward the upper side produces a decrease in the scale  $S$ . If the image lies on the lower side from  $n$ , then  $na$  is considered negative and the equation remains valid.

If the line  $na$  should coincide with the principal line, then  $t' = t$ ,  $\sin t$  would be maximum, and  $\frac{dS}{dy}$  would be maximum for the photograph. Inasmuch as every line of a system of parallel lines on a photograph has an equal inclination with the horizontal, then the rate of scale change along each of them is also equal. It is again evident that the scale is smaller on the upper side of a photograph, or that the detail is smaller or compressed, whereas the scale on the lower side is greater and the detail is larger or expanded.

An important by-product of the proof is a simple relation for finding the tilt of a photograph. Assuming that the line  $na$  coincides with the principal line, equation 3441B can be rearranged by algebra to the form

$$\sin t = H \frac{dS}{dy} \quad (3441C)$$

where  $\frac{dS}{dy}$  is the rate of change of scale on the principal line or on a line parallel to the principal line, and where the negative sign has been dropped. This relation is one of the foundations of the Anderson's scale point method of tilt determination.

*Example 1* Two images that are 22.0 inches apart are known to have the scales 0.0000524 and 0.0000617. Find the rate of change of scale along the line joining the two images.

Solution

$$\begin{aligned} \frac{dS}{dy} &= \frac{\text{total change in scale}}{\text{distance in which the change took place}} \\ \frac{dS}{dy} &= \frac{0.0000617 - 0.0000524}{22.0} = \frac{0.0000093}{22.0} \\ \frac{dS}{dy} &= 0.000000423 \text{ per inch} \end{aligned}$$

*Example 2* Find the tilt of the photograph of example 1 if the flying height is 14,000 feet and if the line joining the two images is parallel to the principal line.

Solution Because  $\sin t = H \frac{dS}{dy}$ ,

$$\begin{aligned} \sin t &= 14000 \times 12 \times 0.000000423 = 0.0711 \\ t &= 4^{\circ}05' \end{aligned}$$

*Example 3* The maximum rate of change in scale is found to be  $3.814 \times 10^{-6}$  from scale numbers (see example in 3442) where  $ab$  and  $y$  are measured in millimeters and  $AB$  is measured in feet for use in  $S = \frac{ab}{AB}$  without conversion. Find the tilt of the photograph if the flying height is 12,900 feet above the average ground elevation.

Solution

$$\begin{aligned} \sin t &= 12,900 \times 3.814 \times 10^{-6} = 0.0492 \\ t &= 2^{\circ}49' \end{aligned}$$

\* Anderson, Ralph O., Applied Photogrammetry, 1946

## 3442 The Scale Point

A scale point is a point on a photograph where the scale is known

The location of the scale point and the value of the scale at that point can be determined by a method of Mr Anderson (see footnote in 3441) Consider two ground objects of equal elevation whose distance apart is known The line drawn through the images of these objects is called a scale-check line and the images are scale-check points The apparent value of the scale of the scale-check line on a photograph can be computed from equation 3221A,  $S = \frac{ab}{AB}$  where  $ab$  is measured on the photograph The point on the line at which this scale value is valid can be found by the following graphic construction (see figure 3 35) (1) construct a perpendicular from the isocenter to the scale-check line, (2) the scale point is as far, but in the opposite direction, from the midpoint of the scale-check line as is the foot of the dropped perpendicular In figure 3 35  $ab$  is the scale-check line,  $ic$  is the dropped perpendicular,  $d$  is the midpoint of the scale-check line, and  $S$  is the scale point It is noteworthy that the scale point can also be located with a pair of dividers without finding the midpoint because  $ac = bS$  and  $aS = bc$

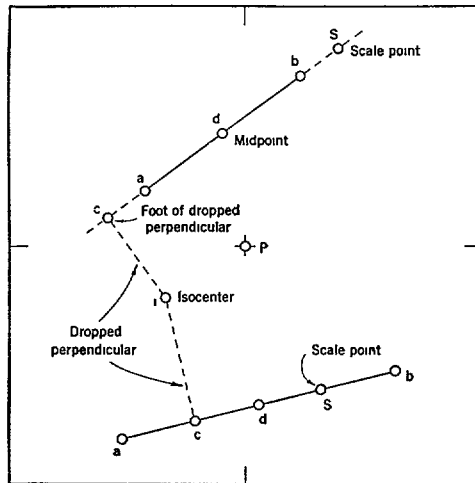

FIGURE 3 35 —Scale point construction

The location and the evaluation of the scale point constitute a basis for the Anderson method of tilt determination The procedure is convenient, relatively accurate, and not difficult to learn The principle is not derived here mathematically because it is an empirical solution A careful study shows that the method is more nearly correct theoretically where (a) the tilt is small, (b) the scale-check line is short, and (c) the dropped perpendicular falls near the end of the scale-check line On single-lens photographs the errors in graphic construction are usually greater than the theoretical error, on nine-lens photographs the reverse is often true The use of the principal point instead of the isocenter introduces a relatively small error where used with near-verticals and the error is smaller on nine-lens than on single-lens photographs The method is based on objects of equal elevation so that a difference in elevation necessitates the application of a relief displacement correction to one or both images The principal line, the maximum rate of change of scale, and the tilt of the photograph can be determined from three scale points

*Example* Two objects are 11,927 feet apart and the distance between the images on a photograph is measured as 742 inches after one of the images is displaced for the elevation difference of the objects. Find the scale value at the scale point.

Solution

$$S = \frac{ab}{AB}$$

$$S = 742 - (11,927 \times 12) = 0.00005184$$

For convenience in connection with this type of work only, the scale value is frequently obtained without changing the numerator and denominator to the same units, as

$$S = 742 - 11,927 = 0.00062212 \text{ inches per foot}$$

Thus  $ab$  can be expressed in millimeters without complicating the problem. The result is further simplified by using the equivalent notation

$$S = 62,212 \times 10^{-8} \text{ inches per foot}$$

In practice the notation is omitted and the number 62,212 is called the scale number.

### 345. SUMMARY OF THE EFFECTS OF TILT

An area on a tilted photograph has an incorrect shape because each of the many points of the boundary of an area is subjected to a different tilt displacement because of the different angles  $\theta$  relative to the principal line and the different radial distances  $r$ . The image of a square level field might be shown as an irregular quadrilateral because of tilt alone, whereas a combination with elevation differences can distort the shape still further. Areas on near-vertical photographs can nevertheless be compiled economically into correct shapes on a map through the use of radial-plotting methods. Tilt alone does not change a straight line into a curved line—if a line is straight on the equivalent vertical photograph it will also appear straight on the tilted one and vice versa. Straight roads are often shown as curved lines on photographs but this is due to elevation differences and relief displacements.

It has already been pointed out that correct horizontal angles do not exist on a tilted photograph of rough terrain. However, angles that are almost correct can be obtained from near-vertical photographs for radial plotting. Angles are usually more nearly correct if the point midway between the isocenter and nadir point is used as the radial center. This is discussed further in 421. The general effect of tilt on radial plotting is to cause small errors in the solutions of the problems of graphic resection and intersection.

The scale of the details of a tilted photograph is not a constant—the upper side is compressed and the lower side is expanded. Occasionally the size (and shape) of a field near the edge of a nine-lens photograph appears greatly different from its size (and shape) near the center of an adjacent photograph, even where the tilt is moderate. Consequently, the photogrammetrist is urged to use only the central portion of a photograph for map compilation. It is also noteworthy that the different dimensions of a feature on a tilted photograph are of different scales because they are of different inclinations (3424) and have different  $y$ -values which affect scale according to equation 3441A. Moreover, a dimension not perpendicular to the principal line has a constantly changing scale throughout its length.

Elevations are not correct if they are obtained directly from tilted photographs. This is the most pronounced and most serious effect of tilt, true even for the usual near-verticals. This applies to both methods (3232 and 3262) for elevation determination. The reason for the alarming error is that tilt displacement is frequently several times the magnitude of the relief displacement of an image, which displacement the photogrammetrist is often unable to isolate without special instruments. Also, the tilt displacement can be negative

or positive, depending on where the image lies with respect to the axis of tilt. The amount of tilt displacement varies approximately as the *square* of the radial distance whereas relief displacement varies only as the *first* power and the two displacements are entirely independent. Intricate stereoscopic plotting instruments (multiplex, stereoplanigraph, etc.) and rectifying cameras are developed primarily to counteract the effects of tilt. Also, simple stereoscopic plotting instruments require an abundance of vertical control to discern and correct the effects of tilt. The stereoscopic model obtained from a pair of tilted photographs using a simple stereoscope is warped in an irregular pattern usually radically different from any other model formed by any other pair.

The assembly of a photograph mosaic is made difficult by the presence of tilt in near-verticals. The reasons are those already mentioned regarding shape and scale. The effects of both tilt and relief are sometimes roughly minimized by approximate rectification.

Tilt in photographs causes  $y$ -parallax (**3263** and **334**) which is a hindrance to the stereoscopic viewing of the photographs. The presence of  $y$ -parallax is sometimes used in the detection and/or computation of tilt of an aerial photograph. The systematic removal of  $y$ -parallax is used to remove the effect of tilt and for the orientation of a pair of photographs in many stereoscopic plotting instruments.

### 346 ANALYTIC PROBLEMS INVOLVING TILT

It is possible to determine ground distances accurately by computation from a tilted photograph in much the same manner as from a vertical photograph (see **327**). A computation that neglects no variable and assumes no untrue condition at all can be performed in a logical and straightforward manner for the determination of exactly consistent horizontal ground distances from the measurements of the coordinates of the images on a tilted photograph. The results of such computations are limited in accuracy only by the accuracy of measurement of the coordinate distances—if the coordinates are correct to five significant digits, then the ground distances are of equal accuracy. The method is not used to a great extent, but it demonstrates that it *can* be done and that there *is* a rigid mathematical relation between the images on a photograph and the ground dimensions. The theory is interesting and educational because its simplicity tends to unveil the mysteries of tilt. This section completes the derivation of the four fundamental problems in photogrammetry of which two were shown in **327**. The four principles are a basis for one of the methods of tilt determination.

A method of determining the exact ground distance between two objects of known elevation is considered first. The coordinates are considered for initial simplicity to be those of a particular required system. Next, a method is demonstrated for transforming a system of coordinates from the usual system to the required system. Finally, the inverse problem is shown for finding the exact flying height of the camera from two ground stations whose elevations and distance apart are known. The application of these principles is valid for any degree of tilt and any elevation difference.

#### 3461 To Find the Exact Ground Distance

The horizontal ground distance between two objects of known elevation can be accurately computed from the coordinates of the two images on a photograph where the following data are known: flying height, focal length, angle of tilt, and the orientation of



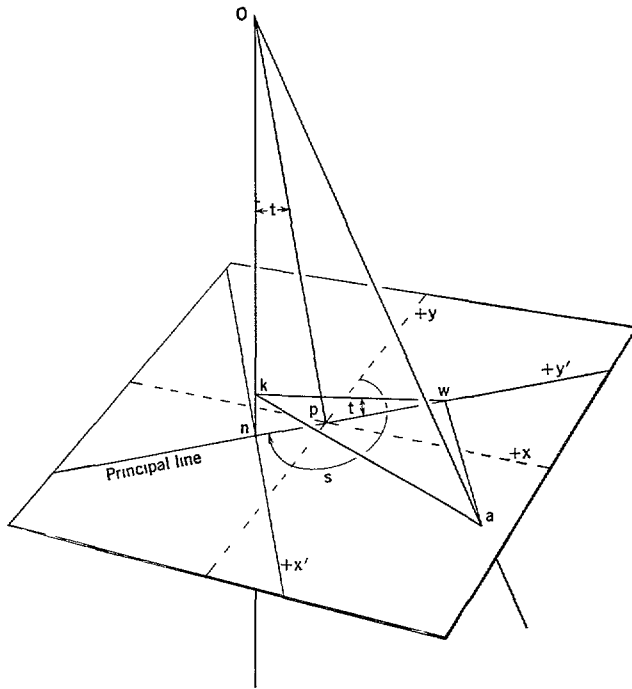

FIGURE 336—Analytic geometry of the tilted photograph

the principal line on the photograph. It is assumed for convenience in introducing the procedure that the image coordinates are given relative to the nadir point as the origin and the upper end of the principal line as the positive  $y$ -axis. If the coordinates are given otherwise, they can be transformed to this system as explained in 3462.

In figure 336,  $a$  is any image on a tilted photograph and  $w$  is the orthogonal projection of  $a$  on the principal line. Then  $aw$  is the  $x'$ -coordinate and  $nw$  is the  $y'$ -coordinate of the image, where the prime is used to denote this special coordinate system. The line  $aw$  is a horizontal line because it is perpendicular to the principal line. The line  $wk$  is constructed perpendicular to the vertical line  $On$  and hence,  $wk$  is also horizontal. The image  $a$  and the triangle  $kwa$  can be considered as part of an untilted photograph whose perspective center is  $O$  and whose focal length is  $Ok$ . In the right triangle  $wkn$ ,

$$nk = nw \sin t = y' \sin t, \text{ and}$$

$$Ok = On - nk$$

Then,

$$Ok = f \sec t - y' \sin t = f'$$

where  $f'$  is used to represent the complete expression. From equation 3222C for a vertical photograph,

$$X = x' \frac{H - h}{f} \tag{3461A}$$

where  $h$  is the elevation of the object,  $H$  is the flying height, and  $X$  is the horizontal ground distance that corresponds to  $x'$ . The coordinate  $X$  is merely a convenient coordi-

nate distance associated with this one photograph—it is not a State coordinate nor is it of any other type of geographic coordinate system. Then also,

$$Y = wk \frac{H - h}{f'}$$

In the right triangle  $wkn$ ,  $wk = y' \cos t$ . Then

$$Y = y' \cos t \frac{H - h}{f'} \tag{3461B}$$

Thus, horizontal coordinates are expressed for a ground object. The coordinates for a second object can be determined from the same equations using the appropriate values for  $h$ ,  $x'$ ,  $y'$ , and  $f'$ . The horizontal ground distance between the two objects is expressed by equation 3271B in terms of the coordinates

$$AB = \sqrt{(X_A - X_B)^2 + (Y_A - Y_B)^2}$$

Thus, the horizontal ground distance is obtained by a method where the tilt and elevation differences have been taken fully into account

*Example* Find the exact ground distance between the two objects *A* and *B* if the given data are

	$r'$ in mm	$y'$ in mm		$h$ in ft
<i>a</i>	-279.83	+89.29	<i>A</i>	120
<i>b</i>	+376.08	+176.76	<i>B</i>	90

$f = 209.5$  mm  
 $t = 1^\circ 41'$   
 $H = 13,897$  feet

Solution From tables,  $\sin t = 0.02938$   
 $\cos t = 0.99957$   
 $f \sec t = 209.59$  mm

	$y' \cos t$	$y' \sin t$	$f'$
<i>a</i>	+89.25	+2.62	206.97
<i>b</i>	+176.68	+5.19	204.40

	$H - h$	$\frac{H - h}{f'}$	$X$	$Y$	$\Delta X$	$\Delta Y$	$AB$
<i>A</i>	13777	66.565	-18627	+5941	-44030	-5994	44436
<i>B</i>	13807	67.549	+25403	+11935			

The answer is  $AB = 44441$  feet

Sample computation

$$y' \cos t = +89.29 \times 0.99957 = +89.25 \text{ mm}$$

$$y' \sin t = +89.29 \times 0.02938 = +2.62 \text{ mm}$$

$$f' = f \sec t - y' \sin t = 209.59 - (+2.62) = 206.97 \text{ mm}$$

(If  $y'$  is negative,  $y' \sin t$  is accordingly added to  $f \sec t$ )

$$H - h = 13897 - 120 = 13777 \text{ feet}$$

$$\frac{H - h}{f'} = \frac{13777}{206.97} = 66.565$$

$$X = x' \frac{H - h}{f'} = (-279.83) \times 66.565 = -18627 \text{ feet}$$

$$Y = y' \cos t \frac{H - h}{f'} = (+89.25) \times 66.565 = +5941 \text{ feet}$$

$$\Delta X = X_A - X_B = (-18627) - (+25403) = -44030 \text{ feet}$$

$$AB = \sqrt{\Delta X^2 + \Delta Y^2} = \sqrt{44030^2 + 5994^2} = 44436 \text{ feet}$$

3462 *Coordinate Transformation*

The coordinates of images can be transformed arithmetically into the particular system assumed in 3461 from any original system of measurement. The particular system has the nadir point as origin and the upper end of the principal line as the positive  $y$ -axis. The system for coordinate measurement usually has the principal point as origin and a line through one of the fiducial marks as one of the axes. The nadir point and principal line usually are not determined before the coordinates are measured. Coordinates in the particular system could be remeasured, but the arithmetic transformation is shorter and more practicable. The transformation consists of a rotation and a translation which are expressed by the equations:

$$x' = -x \cos s + y \sin s \tag{3462A}$$

$$y' = -x \sin s - y \cos s + f \tan t \tag{3462B}$$

Here  $x'$  and  $y'$  are the desired new coordinates and  $x$  and  $y$  are the originally measured coordinates. The angle  $s$  is the *swing* (see figs 3 36 and 3 37) defined as the angle at the principal point measured clockwise from the  $+y$ -axis of the original system to the nadir point. The value  $f \tan t$  is the distance  $pn$  that, after rotation, must be added to all the  $y'$ -coordinates to translate the origin from  $p$  to  $n$ .

Care should be exercised to avoid confusing this definition of swing with the same word used in multiplex work—the two terms have entirely different meanings. In analytic photogrammetry, swing is an angle that denotes the orientation of the principal line on a photograph and hence the direction of the photograph inclination. In multiplex work, swing denotes a horizontal angular orientation of one photograph (diapositive) relative to an adjoining photograph and is not related to the tilt of either photograph.

The derivation of these equations closely resembles the derivation of the formulas for the rotation of the axes in plane analytic geometry. These equations are not exactly like those of analytic geometry because (a) values are expressed here for  $x'$  and  $y'$  in terms of  $x$  and  $y$  whereas the inverse expressions are usually given in analytic geometry, (b) here the angle  $s$  is the angle from the  $+y$ -axis to the  $-y'$ -axis, whereas the angle in geometry is considered from the  $+x$ -axis to the  $+x'$ -axis, (c) here the positive value of

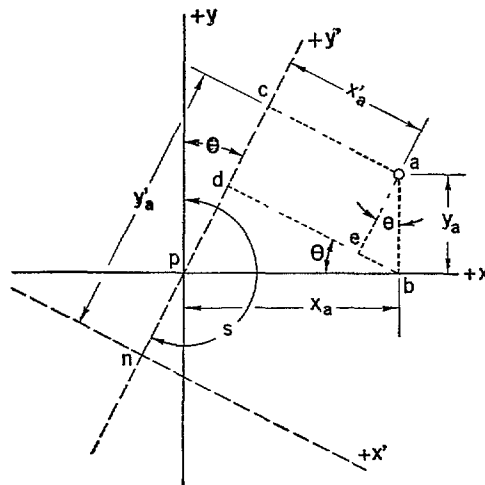

FIGURE 3 37—Coordinate transformation

the angle  $s$  is taken as clockwise to conform with the conventional practice in surveying, whereas in mathematics positive angles are considered counterclockwise, and ( $d$ ) a translation of the origin from the principal point to the nadir point is incorporated in this problem by adding the term  $f \tan t$  to the  $y'$ -coordinate

Let the point  $a$  in figure 3 37 represent an image on a photograph whose initial axes are considered to be the  $x$ - and  $y$ -axes as shown. Let  $x_a$  and  $y_a$  be the measured coordinates of  $a$  relative to these axes, and let  $f$  be the focal length of the photograph. Suppose that at a later time the tilt  $t$  and the swing  $s$  of the photograph had been determined and that the nadir point  $n$  was located in the position as indicated. Then the line  $np$ , extended, is to be the new  $y'$ -axis with  $n$  as the origin, the  $+y'$  end of the  $y'$ -axis is on the upper side of the photograph or in the direction from  $n$  to  $p$ , and the new  $+x'$ -axis is to the right of the  $y'$ -axis as observed at  $n$ .

By construction, the line  $ab$  is perpendicular to the  $x$ -axis,  $ac$  and  $bd$  are perpendicular to the  $y'$ -axis, and  $ae$  is perpendicular to  $bd$ . The angle at  $p$  from the  $+y$ -axis to the  $+y'$ -axis is denoted by the symbol  $\theta$ . Because of the facts that

$$\begin{aligned}\text{angle } s &= \text{angle } ypy' + \text{angle } y'pn, \\ \text{angle } \theta &= \text{angle } ypy' \\ \text{angle } y'pn &= 180^\circ,\end{aligned}$$

then  $\text{angle } s = \theta + 180^\circ$  or  $\theta = s - 180^\circ$ . This relation is valid for all values of  $s$ , but  $\theta$  is negative or counterclockwise if  $s$  is less than  $180^\circ$ . The angles  $bae$  and  $pbd$  are each equal to the angle  $\theta$  because of the perpendicular lines in the construction.

The rectangular coordinates of the image  $a$  in the  $xy$ -system are

$$\begin{aligned}x_a &= pb \\ y_a &= ab\end{aligned}$$

The coordinates of  $a$  in the rotated and translated  $x'y'$ -system are,

$$\begin{aligned}x_a' &= de = bd - be & (3462C) \\ y_a' &= nc = cd + dp + pn & (3462D)\end{aligned}$$

In the right triangle  $pdb$ ,

$$\begin{aligned}bd &= pb \cos \theta = x_a \cos \theta \\ dp &= pb \sin \theta = x_a \sin \theta,\end{aligned}$$

and in the right triangle  $aeb$ ,

$$\begin{aligned}ae &= ab \cos \theta = y_a \cos \theta = cd \\ be &= ab \sin \theta = y_a \sin \theta\end{aligned}$$

It is shown in 3422 that  $pn = f \tan t$ . Then by substitution in equations 3462C and D

$$\begin{aligned}x_a' &= x_a \cos \theta - y_a \sin \theta & (3462E) \\ y_a' &= x_a \sin \theta + y_a \cos \theta + f \tan t & (3462F)\end{aligned}$$

Inasmuch as  $\theta = s - 180^\circ$ , by means of the trigonometric formulas for the sine and cosine of the difference of two angles,

$$\begin{aligned}\sin \theta &= \sin (s - 180^\circ) = \sin s \cos 180^\circ - \cos s \sin 180^\circ \\ \cos \theta &= \cos (s - 180^\circ) = \cos s \cos 180^\circ + \sin s \sin 180^\circ\end{aligned}$$

But  $\sin 180^\circ = 0$  and  $\cos 180^\circ = -1$ , whence

$$\begin{aligned}\sin \theta &= -\sin s \\ \cos \theta &= -\cos s\end{aligned}$$

and the substitution of these terms in equations 3462E and F results in equations 3462A and B. The derivation of these equations is not perfectly general inasmuch as it is based on the special case where  $a$  is in the first quadrant and  $n$  is in the third quadrant of the  $x$ - $y$ -system, but the equations are valid also for all other locations of  $a$  and  $n$ , and the derivation can be performed in a similar manner for any other arrangement of the positions of the two points.

The inverse forms of equations 3462A and B which express  $x$  and  $y$  in terms of  $x'$  and  $y'$  are sometimes useful in research. The equations can be derived by a geometric method similar to that above, or by an algebraic solution considering equations 3462A and B as two simultaneous linear equations in two unknowns,  $x$  and  $y$ . The steps of the derivation are not shown, but the resulting equations are

$$x = -x' \cos s - (y' - f \tan t) \sin s \tag{3462G}$$

$$y = x' \sin s - (y' - f \tan t) \cos s \tag{3462H}$$

*Example* Compute the  $x'$ - and  $y'$ -coordinates from the following data

	$x$	$y$	$f = 209.5 \text{ mm}$
$a$	-289.5	-37.9	$t = 1^\circ 41'$
$b$	+274.2	+308.9	$s = 156^\circ 00'$

*Solution* From tables,

$$\sin s = +0.40674$$

$$\cos s = -0.91355$$

$$\tan t = 0.02939$$

$$f \tan t = 6.16 \text{ mm}$$

	$-x \cos s$	$+y \sin s$	$-x \sin s$	$-y \cos s$	$x'$	$y$
$a$	-264.47	-15.42	+117.75	-34.62	-279.89	+89.29
$b$	+250.50	+125.64	-111.53	+282.20	+376.14	+176.83

*Sample computation*

$$x' = -(-289.5)(-0.91355) + (-37.9)(+0.40674) = -264.47 - 15.42 = 279.89 \text{ mm}$$

$$y' = -(-289.5)(+0.40674) - (-37.9)(-0.91355) + 6.16 = +117.75 - 34.62 + 6.16 = 89.29 \text{ mm.}$$

### 3463 Relation of Tilt, Swing, and Nadir Point

The location of the nadir point is related to the tilt and the swing of a photograph through several useful expressions. The values  $x_n$  and  $y_n$  are the rectangular coordinates and  $\rho_n$  and  $s$  are the polar coordinates of the nadir point relative to the principal point as origin and one of the fiducial axes as the  $+x$ -axis (Polar coordinates are two numbers that define the location of a point, of which one number is the radial distance from an origin or pole to the point and the other number is the angle measured from a given reference line or polar axis to the radial line through the point.) The following equations are obvious (see fig. 338)

$$pn = \sqrt{x_n^2 + y_n^2} \quad (3463A)$$

From equation 3422A,

$$\tan t = \frac{pn}{f} \quad (3463B)$$

$$\tan s = \frac{x_n}{y_n} \quad (3463C)$$

The algebraic signs of the numerator and denominator denote the proper quadrant in exactly the same manner as in trigonometry

$$\sin s = \frac{x_n}{pn} \quad (3463D)$$

$$\cos s = \frac{y_n}{pn} \quad (3463E)$$

The algebraic signs of  $\sin s$  and  $\cos s$  are the same as for  $x_n$  and  $y_n$ , respectively

The resultant tilt  $t$  is often considered as composed of the two right-angle component tilts  $x$ -tilt,  $t_x$ , and  $y$ -tilt,  $t_y$ . The  $x$ -tilt is defined as the angular inclination of the  $x$ -axis to the horizontal. The  $x$ -tilt is then related to the  $y$ -coordinate  $y_n$  of the nadir point and hence to the cosine function of the angle  $s$ . Substitution in equation 3424A shows that

$$\sin t_x = \sin t \cos s \quad (3463F)$$

where  $t_x$  corresponds exactly to  $t'$  and  $s$  corresponds exactly to  $\theta$  measured in the plane of the photograph

Similarly,

$$\sin t_y = \sin t \sin s \quad (3463G)$$

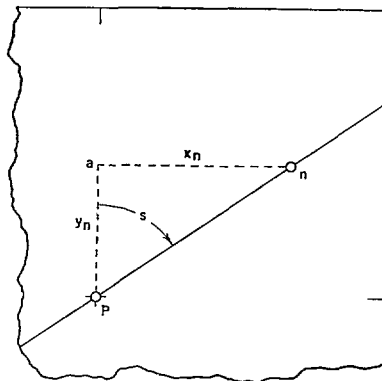

FIGURE 3 38 —Nadir point relations

Because  $\tan t = \frac{pn}{f}$ , substitution of equations 3463D and E in equations 3463F and

G shows that

$$\sin t_x = \frac{y_n}{f} \cos t \quad (3463H)$$

$$\sin t_y = \frac{x_n}{f} \cos t \quad (3463I)$$

Equation 3463H might seem to be in error in view of the similarity to the method used for deriving  $\tan t = \frac{pn}{f}$  in 3422. One is tempted to write  $\tan t_x = \frac{y_n}{f}$ , but this is not true because the angle  $pOa$  whose tangent is  $\frac{y_n}{f}$  lies in an inclined plane, whereas  $t_x$  is an angle measured in the vertical plane that contains the plum line  $On$ . By the companion definition to tilt,  $t_x$  is the angle formed between the  $x$ -axis and the horizontal plane, and equation 3424A applies.

Squaring both sides of equations 3463F and G and adding them results in

$$\sin^2 t_x + \sin^2 t_y = \sin^2 t \cos^2 s + \sin^2 t \sin^2 s = \sin^2 t (\cos^2 s + \sin^2 s)$$

The term in parentheses is identically equal to one by trigonometry, whence

$$\sin^2 t = \sin^2 t_x + \sin^2 t_y \quad (3463J)$$

By substituting in equation 3463C for the expressions for  $x_n$  and  $y_n$  from equations 3463H and I,

$$\tan s = \frac{\sin t_y}{\sin t_x} \quad (3463K)$$

Thus the tilt of a photograph can be expressed by two different methods of notation (1) tilt and swing and (2)  $x$ -tilt and  $y$ -tilt. Equations 3463J and K express  $t$  and  $s$  in terms of  $t_x$  and  $t_y$ , whereas equations 3463F and G express  $t_x$  and  $t_y$  in terms of  $t$  and  $s$ .

*Example 1* Determine the resultant tilt, swing,  $x$ -tilt and  $y$ -tilt of a photograph whose focal length is 152.2 mm where the  $x$ - and  $y$ -coordinates of the nadir point are known to be +9.23 mm and -3.67 mm, respectively.

Solution

$$\begin{aligned} pn &= \sqrt{9.23^2 + 3.67^2} = 9.933 \text{ mm} \\ \tan t &= \frac{9.933}{152.2} = 0.06526 \\ t &= 3^\circ 44' \\ \tan s &= \frac{+9.23}{-3.67} = -2.5150 \\ s &= 111^\circ 41' \\ \sin t_x &= \frac{-3.67}{152.2} \cos 3^\circ 44' = -0.02411 \times 0.99788 = -0.02406 \\ t_x &= 1^\circ 22' 7'' \\ \sin t_y &= \frac{+9.23}{152.2} \times 0.99788 = +0.06052 \\ t_y &= +3^\circ 28' 1'' \end{aligned}$$

The algebraic signs of the angles  $t_x$  and  $t_y$  correspond to the signs of the coordinates  $y_n$  and  $x_n$ , respectively. The direction of the inclination (clockwise or counterclockwise) depends on the point of view (which end of the axis) and the position of the nadir point as indicated by the signs of  $x_n$  and  $y_n$  (the nadir point is always lower than the principal point).

*Example 2* What are the  $x$ -tilt and  $y$ -tilt of a photograph where the resultant tilt and swing are  $2^\circ 11' 0''$  and  $287^\circ 19'$ , respectively?

Solution

$$\begin{aligned}\sin t_x &= \sin 2^\circ 11' 0 \cos 287^\circ 19' \\ &= 0.03810 (+0.29765) = +0.01134 \\ t_x &= 0^\circ 39' 0 \\ \sin t_y &= \sin 2^\circ 11' 0 \sin 287^\circ 19' \\ &= 0.03810 (-0.95467) = -0.03637 \\ t_y &= -2^\circ 05' 1\end{aligned}$$

The algebraic signs of the angles indicate the quadrant in which the nadir point lies

### 3464 To Find the Exact Flying Height

The method for obtaining the exact flying height of a tilted photograph is demonstrated with an example only. The known data are considered as being (a) the focal length, tilt, and swing of the photograph, (b) the elevations of two objects and the horizontal distance between them, and (c) the coordinates of the images of the two objects. The procedure is one of successive approximations very similar to that of 3272. The scheme for observing the tilt is that of 3461 together with coordinate transformation (see 3462).

*Example* Find the flying height correct to the nearest foot from the given data. The flying height was supposed to have been 7000 feet.

Given

	<i>x</i>	<i>y</i>		<i>h</i>	<i>f</i> = 209.70 mm
<i>a</i>	-353.59	+220.79	<i>A</i>	107	<i>t</i> = 4°09'0
<i>b</i>	+231.09	+363.83	<i>B</i>	1611	<i>s</i> = 251°06'
					<i>AB</i> = 17144 feet

Solution From tables,  $\tan t = 0.07256$      $\sin s = -0.94609$   
 $\sin t = 0.07237$      $\cos s = -0.32392$   
 $\cos t = 0.99738$

Initial constants  $pn = f \tan t = 15.22$  mm  
 $On = f \sec t = 210.25$  mm

Transformation and "analytic rectification"

	$-x \cos s$	$+y \sin s$	$-x \sin s$	$-y \cos s$	$x'$	$y'$	$y' \cos t$	$y' \sin t$	$f'$
<i>a</i>	-114.53	-208.89	-334.53	+71.52	-323.42	-247.79	-247.14	-17.93	228.18
<i>b</i>	+74.85	-344.22	+218.63	+117.85	-269.37	+351.70	+350.78	+25.45	184.80

The computation up to this point is final and is not repeated in the successive approximations.

Using  $H = 7000$ , the following computation for the distance  $AB$  is the same as in 3272 where  $f' = f \sec t - y' \sin t$  is used in place of  $f$ ,  $X = x' \frac{(H-h)}{f'}$  and  $Y = y' \cos t \frac{(H-h)}{f'}$

	$(H-h)$	$\frac{(H-h)}{f'}$	$X$	$Y$	$\Delta X$	$\Delta Y$	$AB$
<i>A</i>	6893	30.209	-9770	-7466	-1915	-17695	17798
<i>B</i>	5389	29.161	-7855	+10229			

The value for  $AB$  is in error because the assumed value of  $H$  was not correct. The flying height is accordingly adjusted using equation 3272

$$\begin{aligned}H &= h_m + (H_t - h_m) \frac{AB}{(AB)_t} \\ h_m &= \frac{1}{2} (107 + 1611) = 859 \\ H &= 859 + (7000 - 859) \frac{(17144 - 17798)}{17798} = 6774 \text{ feet}\end{aligned}$$



The following is the computation for  $AB$  using the adjusted value for the flying height

	$H - h$	$\frac{H - h}{f'}$	$X$	$Y$	$\Delta X$	$\Delta Y$	$AB$
$A$	6667	29 218	- 9450	- 7221	- 1924	- 17021	17130
$B$	5163	27 938	- 7526	+ 9800			

The value  $AB$  is still not correct,  $H$  is again adjusted and the computation is repeated

$$H = 859 + (6774 - 859) (17144) - (17130) = 6779 \text{ feet}$$

	$H - h$	$\frac{H - h}{f'}$	$X$	$Y$	$\Delta X$	$\Delta Y$	$AB$
$A$	6672	29 240	- 9457	- 7226	- 1924	- 17036	17144
$B$	5168	27 965	- 7533	+ 9810			

The fact that the value  $AB$  for the length of the line is exactly correct shows that the corresponding flying height value of 6779 feet is also exactly correct

### 347 APPLICATION OF SOLID ANALYTIC GEOMETRY<sup>4</sup>

The principles of solid analytic geometry are sometimes very useful in the study of advanced problems of photogrammetry. A few of those mathematical fundamentals that are applicable to aerial photographs are briefly reviewed here. No attempt is made to show proofs of the principles because they are usually direct applications of derivations which are contained in many current textbooks on analytic geometry.

A tilted aerial photograph (figure 339) is considered on which appear the images  $a, b,$  and  $c$  of three ground objects  $A, B,$  and  $C$ . The ground objects can be regarded as control stations for which are known the  $X$ - and  $Y$ -coordinates with respect to some oriented geographic system, and also the elevations  $Z$  relative to a recognized horizontal plane, such as sea level. The geographic coordinates of the object  $A$  are symbolized here as  $X_A', Y_A',$  and  $Z_A'$ , and similarly for the other objects. The perspective center  $O$  of the photograph is also considered as having geographic coordinates  $X_o', Y_o', Z_o'$  in the same ground system. The latter values are also spoken of as the three position elements of space resection (3534). It is convenient in most problems to regard  $O$  as the origin of the system of ground coordinates, whence the new coordinate values for the objects  $O, A, B,$  and  $C$  will be different from the original geographic values as defined by the equations of translation

$$\begin{aligned} X_o &= Y_o = Z_o = 0 \\ X_A &= X_A' - X_o', \text{ etc.}, \end{aligned} \tag{347A}$$

in which  $X_A, Y_A,$  and  $Z_A$  represent the coordinates of the object  $A$  referred to the new origin  $O$ . It is perhaps evident that the  $Z$ 's will be negative, which is reasonable if upward is to be considered as the positive  $Z$ -direction.

*Example 1* If the coordinates of an object are given as  $X' = 2,527,931,$   $Y' = 864,921,$  and  $Z' = 621$  feet, and the coordinates of the camera at the instant of exposure are  $2,532,869, 860,177,$  and  $10,124$  feet, find the coordinates of the station referred to the camera station.

Solution  $X = 2,527,931 - 2,531,869 = - 3938$  feet  
 $Y = 864,921 - 860,177 = + 4744$  feet  
 $Z = 621 - 10,124 = - 9503$  feet

<sup>4</sup> Church, Earl, Theory of Photogrammetry, 1948, pp 10-23

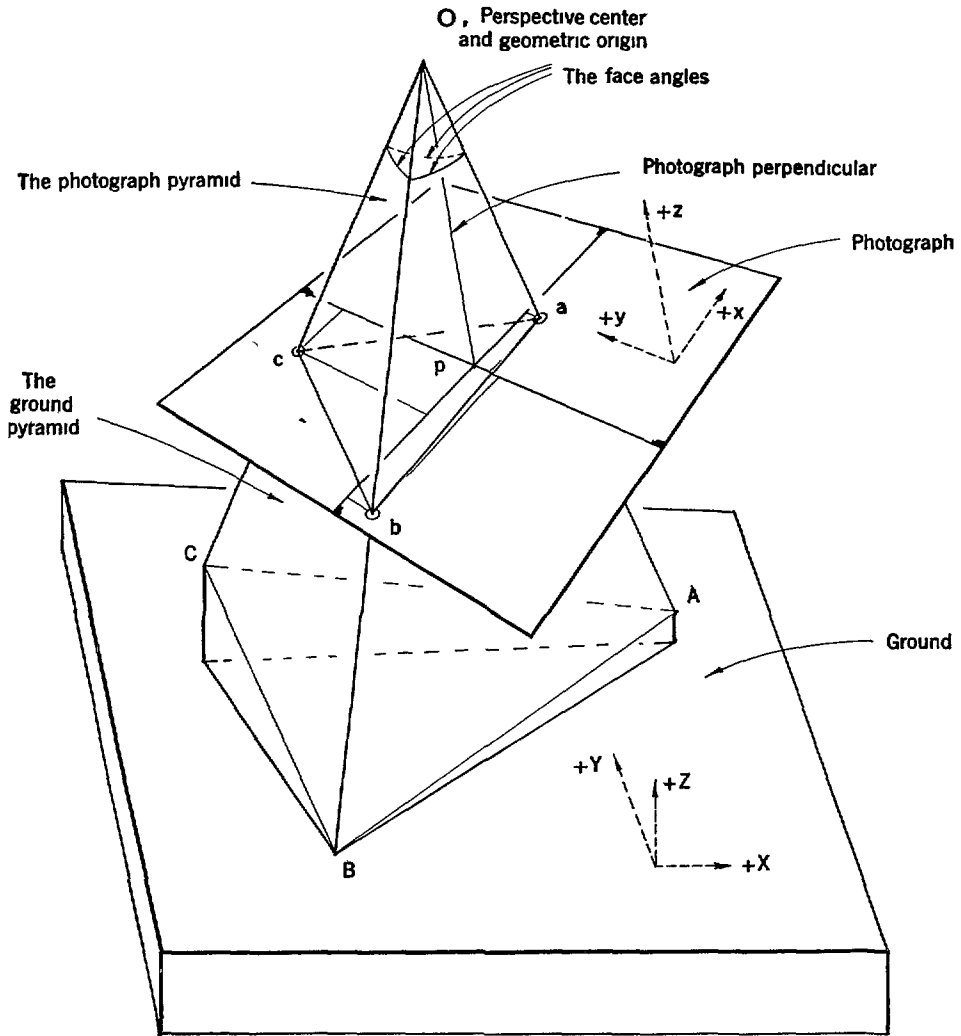

FIGURE 3 39 —Solid analytic geometry of the aerial photograph

The shortest distance between any two points whose space coordinates are known is given by

$$D = \sqrt{\Delta X^2 + \Delta Y^2 + \Delta Z^2} \tag{347B}$$

where  $\Delta$  signifies *difference*. For example,

$$\Delta X_{AB} = X_A - X_B$$

As a special case of equation 347B, the slope distance from  $O$  to  $A$  can be expressed as

$$D_{OA} = \sqrt{X_A^2 + Y_A^2 + Z_A^2}$$

because the coordinates of  $O$  are each zero

The photograph image coordinate system is also referred to the perspective center as its origin. Capital letters are used to symbolize all points, distances, angles, etc., that are referred to the ground system of coordinates, or that are normally considered as belong-

ing in that system, and lower-case letters are used to designate those elements that are referred to the photograph coordinate system. The  $x$ - and  $y$ -axes are considered as being lines at right angles through the perspective center and parallel to the respective axes of the photograph. Inasmuch as the photograph might be tilted, the axes might be inclined lines rather than horizontal lines. The coordinate axes of the photograph can be *any* two perpendicular lines that lie on the photograph and intersect at the principal point. It is customary, however, to let the fiducial marks of the photograph determine the axes, and to choose as the  $x$ -axis the fiducial axis that is more nearly parallel to the flight line with  $+x$  in the direction of flight. The  $z$ -axis is considered as coinciding with the photograph perpendicular, which is not vertical if the photograph is tilted. In view of the facts that  $+z$  is considered as the upward direction, and the distance  $Op$  is the focal length  $f$  of the aerial camera, the  $z$ -coordinate of every image has the value  $-f$ . It should be evident that the  $x$ - and  $y$ -coordinates of the images with respect to  $O$  are identical, respectively, to the photograph coordinates of the images measured with respect to the principal point  $p$  as the origin. As an application of equation 347B, the distance  $d$  from  $O$  to the image  $a$  is

$$d = \sqrt{x_a^2 + y_a^2 + z_a^2}$$

*Example 2* Compute the distance between the perspective center and the image whose coordinates are  $x = +94.87$  mm and  $y = -102.41$  mm, where the camera focal length was 98.17 mm.

Solution:

$$d = \sqrt{94.87^2 + 102.41^2 + 98.17^2} = 170.66 \text{ mm}$$

In plane surveying it is possible to indicate completely the direction of a line with a single angular value, such as the azimuth of the line. In solid geometry, however, *three* angles are required to completely specify the direction of a line in space. The angles are customarily taken as the smaller of the two that a line makes with the positive end of the  $x$ -axis,  $y$ -axis, and the  $z$ -axis. These angles are called direction angles. If a given line does not intersect an axis, the direction angle is the angle between the axis and an intersecting line which is parallel to the given line. It is seldom necessary, however, to determine or consider the values of the angles. The cosines of the direction angles—*direction cosines*—completely specify the direction of a line in space because the cosines of angles between  $0^\circ$  and  $90^\circ$  are positive, the cosines of angles between  $90^\circ$  and  $180^\circ$  are negative, and all direction angles are less than  $180^\circ$ . The Greek letters  $\alpha$ ,  $\beta$ , and  $\gamma$  are usually employed to designate the angles a line makes with the  $x$ -,  $y$ -, and  $z$ -axis, respectively. The letters  $l$ ,  $m$ , and  $n$  are used here to designate the cosines of the three direction angles, respectively, or

$$\begin{aligned} l &= \cos \alpha \\ m &= \cos \beta \\ n &= \cos \gamma \end{aligned} \tag{347C}$$

Similarly, the letter  $L$  is used to designate the cosine of the angle that a given line makes with the  $X$ -axis in the ground coordinate system. The three direction cosines of a line are related in that the sum of their squares is equal to one

$$l^2 + m^2 + n^2 = 1$$

The values of the direction cosines can be determined by means of the relations from analytic geometry

$$l = \frac{\Delta x}{d}, m = \frac{\Delta y}{d}, n = \frac{\Delta z}{d} \tag{347D}$$

in which  $d$  is the distance expressed in equation 347B. In photogrammetry, however, most

of the lines that are considered are object rays that pass through the perspective center or origin, whence the relations are usually of the form

$$l = \frac{x}{d}, m = \frac{y}{d}, n = \frac{z}{d} \quad (347E)$$

The algebraic sign of a direction cosine is the same as that of the related coordinate value, or numerator, because  $d$  is always considered as positive

*Example 3* Determine the three direction cosines of the line from the perspective center to the image point of *example 2*

Solution From *example 2*,  $d = 170.66$  mm

$$\begin{aligned} l &= \frac{+94.87}{170.66} = +0.55590 \\ m &= \frac{-102.41}{170.66} = -0.60008 \\ n &= \frac{-98.17}{170.66} = -0.57524 \end{aligned}$$

The cosine of the angle  $\theta$  between two intersecting lines whose direction cosines are  $l_1, m_1, n_1$ , and  $l_2, m_2, n_2$  is given by the relation

$$\cos \theta = l_1 l_2 + m_1 m_2 + n_1 n_2 \quad (347F)$$

*Example 4* The direction cosines of a line are  $-0.35107$ ,  $+0.28780$ , and  $-0.89103$ . Determine the angle between this line and the line of *example 3*

Solution Equation 347F is applied

$$\begin{aligned} \cos \theta &= (+0.55590)(-0.35107) + (-0.60008)(+0.28780) + \\ &\quad (-0.57524)(-0.89103) = +0.14469 \\ \theta &= 81^\circ 40' 8 \end{aligned}$$

At least two equations are required to completely specify the position and direction of a line in space. The equations of a line in terms of the known coordinates  $x_1, y_1, z_1$  and  $x_2, y_2, z_2$  of two points on the line are expressed as

$$\frac{x - x_1}{x_2 - x_1} = \frac{y - y_1}{y_2 - y_1} = \frac{z - z_1}{z_2 - z_1} \quad (347G)$$

which can be written as two independent equations, and in which the  $x, y$ , and  $z$  terms that have no subscripts are the variables. The equations of a line in terms of the coordinates of one point on the line and the direction cosines of the line are

$$\frac{x - x_1}{l} = \frac{y - y_1}{m} = \frac{z - z_1}{n} \quad (347H)$$

If the line passes through the origin, then the equations are simply

$$\frac{x}{l} = \frac{y}{m} = \frac{z}{n} \quad (347I)$$

*Example 5* Write the equations for the line of *example 2*

Solution

$$\frac{x}{0.55590} = \frac{y}{-0.60008} = \frac{z}{-0.57524}$$

The first two parts, and the first and third parts, are combined algebraically so as to be in the form

$$\begin{aligned} 0.60008x + 0.55590y &= 0 \\ 0.57524x + 0.55590z &= 0 \end{aligned}$$

The equation formed by combining the second and third parts can be used in place of either of those shown, but only two of the three possible equations are needed and the third one is a repetition of the mathematical facts implied by the first two

The equation of a plane in space consists of a single, simple, linear equation in three unknowns of the general form

$$ax + by + cz = d$$

where  $a$ ,  $b$ ,  $c$ , and  $d$  are constant values

If two lines intersect, or if a line and a plane intersect, the coordinates of the point of intersection can be determined by a simultaneous solution of all the equations involved. The solution by means of substitution is usually the most applicable.

Inasmuch as the photographic system of coordinates and the ground system of coordinates are two independent systems whose origins are at the same point, the orientation of the photographic system is completely specified if there are stated the three direction cosines of each of the three ground axes in terms of the photographic system. These nine cosines are sometimes spoken of as the elements of space orientation. If  $u_1$ ,  $v_1$ , and  $w_1$  are the direction cosines of the  $X$ -axis in the  $xyz$ -system of coordinates, and  $u_2$ ,  $v_2$ , and  $w_2$  are the direction cosines of the  $Y$ -axis in the  $xyz$ -system, and similarly for the  $Z$ -axis, the nine values can be tabulated in a square array called a matrix,

$$\begin{pmatrix} u_1 & v_1 & w_1 \\ u_2 & v_2 & w_2 \\ u_3 & v_3 & w_3 \end{pmatrix} \tag{347J}$$

Then  $u_1$ ,  $u_2$ , and  $u_3$  are also the three direction cosines of the  $x$ -axis in the  $XYZ$ -system, and similarly for the other axes. It should be evident that  $w_3$  is the cosine of the angle of tilt because it is the cosine of the angle between the  $z$ -axis (the photograph perpendicular) and the  $Z$ -axis (the plumb line), or

$$\cos t = w_3 \tag{347K}$$

It may not be so evident, but it is nevertheless true, that

$$\tan s = \frac{-u_3}{-v_3} \tag{347L}$$

$$\tan \alpha_{NP} = \frac{-w_1}{-w_2} \tag{347M}$$

in which  $s$  is the swing as defined in 3462 and  $\alpha_{NP}$  is the geographic azimuth of the principal plane in the direction from the nadir point toward the principal point.

*Example 6* The orientation elements for a photograph are expressed as

$$\begin{pmatrix} +0.21090 & -0.97510 & +0.06847 \\ +0.97679 & +0.21291 & +0.02346 \\ -0.03745 & +0.06194 & +0.99738 \end{pmatrix} .$$

What is the tilt, swing, and the azimuth of the principal plane?

Solution

$$\cos t = 0.99738, \quad t = 4^\circ 09' 0''$$

$$\tan s = \frac{-(-0.03745)}{-(+0.06194)} = \frac{+0.03745}{-0.06194} = -0.6046, \quad s = 148^\circ 50'$$

$$\tan \alpha_{NP} = \frac{-(+0.06847)}{-(+0.02346)} = \frac{-0.06847}{-0.02346} = +2.919, \quad \alpha_{NP} = 251^\circ 05'$$

The nine direction cosines of the matrix are not totally independent values. The sum of the squares of the elements of any row or any column of the matrix is equal to one. The sum of the products of corresponding elements of any two columns or any two rows is zero, or more specifically,

$$u_1u_2 + v_1v_2 + w_1w_2 = 0$$

The value of the determinant of the matrix is either  $+1$  or  $-1$ . The nine elements can be determined in the solution of the problem of space orientation (353) which follows the solution of the space resection problem.

The elements of the matrix are also the elements of a linear orthogonal transformation because they enable one to compute the coordinates of a point in either system from the given coordinates of the same point in the other system. This characteristic constitutes perhaps the chief mathematical significance of this matrix. If  $X$ ,  $Y$ , and  $Z$  are known for a point, and if the elements of the matrix are known, then

$$x = Xu_1 + Yu_2 + Zu_3 \quad (347N)$$

and similarly for the other coordinates. Conversely, if  $x$ ,  $y$ , and  $z$  are known, then, for example,

$$Y = xu_2 + yv_2 + zw_2 \quad (347P)$$

and similarly for the other coordinates. These relations closely resemble the rotation equations of plane analytic geometry (3462).

*Example 7* Using the coordinates of the photographic image given in *example 2*, and the orientation elements of *example 6*, compute the  $X$ -coordinate of the image in the geographic system.

*Solution* Applying equation 347P to the  $X$ -coordinate

$$X = xu_1 + yv_1 + zw_1$$

$$X = (+94.87)(+0.21090) + (-102.41)(-0.97510) + (-98.17)(+0.06847)$$

$$X = +113.15 \text{ mm}$$

Relations like 347N and P are also valid with respect to the direction cosines of the same line in the two systems, or

$$m = Lv_1 + Mv_2 + Nv_3, \text{ etc} \quad (347Q)$$

Equations 347Q are extremely significant. The problem of space resection (3534) enables one to determine the values of  $L$ ,  $M$ , and  $N$  for three lines from the origin to the ground. It has been shown that  $l$ ,  $m$ , and  $n$  can be determined for any line from the photograph coordinates alone without any form of ground control. Then with the relations 347Q, the values of each of the elements of the matrix can be regarded as unknowns, and their values can be solved by simple linear simultaneous equations in three unknowns.

The three face angles (see fig. 339) of the pyramid  $Oabc$  formed by the perspective center and the lines to three image points on the photograph are equal, respectively, to the three face angles of the pyramid  $OABC$  formed by the same perspective point and the lines to the three ground objects, *regardless of the magnitude and direction of the tilt* of the photograph, or the values of  $t$ ,  $s$ , and  $\alpha_{NP}$ . The statement should be evident from the figure because the lines forming the face angles are collinear in the two pyramids, or the faces of the pyramids are in mutual contact at the top of the ground pyramid. The statement implies that the respective values for  $k$  and  $K$ , the cosines of the face angles of the pyramids (equation 347F), are equal, although the values of the  $l$ 's,  $m$ 's, and  $n$ 's are not equal respectively to the values of the  $L$ 's,  $M$ 's, and  $N$ 's for the same two lines. This principle is the basis for the solution of the space resection problem of Professor Church (3534) (see footnote in 347).

### 35 TILT DETERMINATION

Two practical methods are presented for finding the tilt, swing, and flying height of a near-vertical photograph and other methods are discussed. The Displacement Method is a rapid approximate one useful for large photographs only, and is based on the appearance

of the tilt displacements exhibited in a radial plot. The Scale Point Method is applicable to all near-vertical photographs and is a semigraphic solution of comparatively high accuracy. The Space Resection Method is a precise one that utilizes the principles of solid analytic geometry. The latter methods are only recommended for use where exact results are important and the large expenditure of computation time required is warranted.

Equations can be written showing the relation of tilt, swing, and flying height to the coordinates of images of objects of known position and elevation, but the equations are so involved that they are not solvable by any simple direct method. Consequently, a solution is usually based on some assumption of a near-truth, or else is performed by a system of successive approximations, or both. This is not a particularly strange situation. For example, if it were not for trigonometric tables, the seemingly simple task of finding the angle that corresponds to a known value of the sine function would require a rather involved solution using several terms of an infinite series rather than a direct solution. The solution for tilt by the Displacement Method requires that the position of the principal line be estimated from the appearance of the displacements, the Scale Point Method not only requires a second or third solution but it is also based on a nonrigid method for the location of the scale point, and the other methods are purely ones of successive approximations.

Any method of tilt determination is based on ground control in one form or another because the tilt angle is referred to the normal to the earth's spheroid, and the flying height is a function of a ground distance. Theoretically the determination of the three elements requires the consideration of at least three images of objects whose relative positions and elevations are known. Quite accurate equivalent data are sometimes obtainable by means of horizon cameras and a statoscope.

The relative location of the three ground control stations is of importance in somewhat the same manner as the location of control in graphic resection or the three-point problem. The strongest solution exists where the three control points form a large equilateral triangle symmetrical with respect to the nadir point. No solution exists if the three points lie on the same straight line. The Displacement Method does not rely directly on ground control stations but uses the many points derived by a controlled radial plot. The Scale Point Method requires from three to six ground control stations. The analytical methods use only three ground control stations but they can usually be adapted to use any larger number.

### 351 THE DISPLACEMENT METHOD

The Displacement Method of tilt determination is an approximate one well-adapted to large photographs where there are numerous points whose positions and elevations are known. The control need be nothing more than photogrammetric points determined by a radial plot, where the points are at sea level or where their elevations can be determined within 20 feet from any source whatsoever. The transparent hand templates that were used in a previously made radial plot are used in the solution. The map positions of the photogrammetric points are then in the form of small needle holes on the radial lines of the template.

The holes in the templates denote true map positions at the scale of the map projection on which the plot was assembled. If the template is placed back on the photograph, with their centers coinciding, there is a noticeable variation in the distances between the photograph positions and the template positions (See fig. 340.) These distances are called displacements. Each displacement is a summation or resultant of the three independent component displacements due to relief, scale, and tilt, assuming, of course, that paper, film,

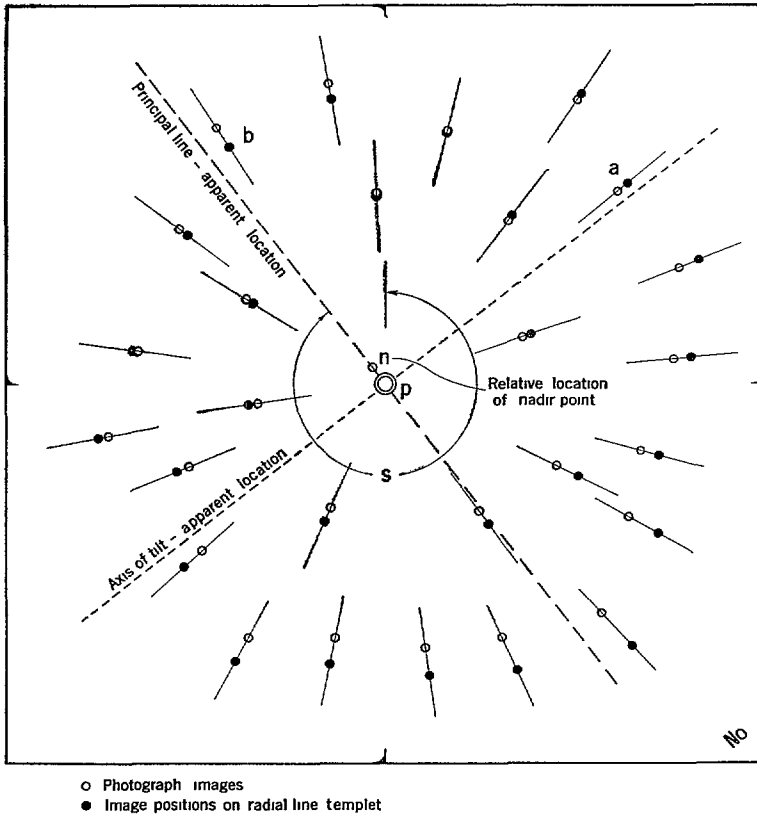

FIGURE 340—Sketch showing typical displacement pattern due to tilt, scale, and moderate relief

and templet shrinkages are small enough to be ignored. The procedure is to remove systematically the first two component displacements to exhibit the tilt displacement which can then be measured. It is shown in 3432 how tilt displacement and the distance to the isocenter are specifically related to the tilt of a photograph.

The accuracy of the method is something of the order of  $\pm 10$  minutes of tilt,  $\pm 10^\circ$  of swing, and  $\pm 1.5$  percent in flying height. The sources of error are chiefly in the radial-plot positions, in measuring and laying off distances, and in the fact that the principal point is used in place of the isocenter.

The procedure is outlined in a series of steps:

*1 To find the swing angle*—If the relief displacements and the scale difference are not relatively great, the position of the principal line can be ascertained by observation to within about  $10^\circ$  without any computations or measurements. If the relief and scale components are large with respect to the tilt components, then the relief corrections must be applied to several points on the templet (as shown in step 2) before the swing angle can be determined. Along the principal line the displacements due to tilt are largest. The photograph images appear beyond the templet positions on the lower side and nearer the center than the templet positions on the upper side of a tilted photograph. The axis of tilt is perpendicular to the principal line and, for these purposes, it is considered as passing through the principal point. The displacements of objects of equal elevation lying on the axis of tilt on opposite sides of the principal point are either outward on both sides or they are inward on both sides. Thus the principal line can be drawn on the photograph or the templet. The nadir point is located on the lower side of the principal line—the side on which the images are displaced outward due to tilt. The distance to the nadir point cannot be determined yet. The swing angle as defined in 3462 can be



measured with a protractor, if desired. The  $+y$ -axis of a nine-lens photograph is considered as the side away from the observer when the number is in the lower right-hand corner.

2 *Relief displacement*—Select a photogrammetric point  $a$  on or near the axis of tilt 250 mm or more from the center and where the ground elevation is known. Correct the templet position of the point by displacing it *outward* a distance  $d_o$  in accordance with equation 3232B

$$d_o = \frac{r'h}{H_t - h}$$

Here  $H_t$  is the theoretical flying height that would have been necessary to make a photograph having the same datum scale as that of the templet or map sheet. The value of  $H_t$  can be found from equation 3222B,  $H_t = \frac{f}{S}$ , where  $S$  is the scale of the map and templet.

3 *Scale factor*—The displacement apparent between the corrected templet position and the photograph position is due entirely to scale, because tilt displacement is nonexistent on the axis of tilt. Measure the radial distance  $r_p$  from the center of the photograph to the image, and measure the corresponding radial distance  $r_t$  from the center of the templet to the needle hole that has been corrected for relief by step 2. Then compute the magnification  $m$  from the equation

$$m = \frac{r_t}{r_p}$$

which is the magnification factor required to change photograph distances to equal templet distances. It is also a divisor for changing a corrected templet radial distance to the corresponding equivalent vertical photograph distance.

4 *Flying height*—If it is desired, the actual flying height  $H_p$  of the photograph can be obtained from

$$H_p = mH_t$$

5 *The tilt*—Select another photogrammetric point  $b$  on or near the principal line 250 mm or more from the center where the ground elevation is known. Correct the templet position for the elevation in the same manner as in step 2. Then further correct the new corrected position for scale by (a) measuring the radial distance  $r_t$  from the center of the templet to the corrected position of the image, (b) computing the scale-corrected radial distance  $r_t'$  from the relation

$$r_t' = \frac{r_t}{m}$$

and (c) measuring off this corrected radial distance to locate a new point on the templet that corresponds to the photograph image position which point is now free from the effects of relief and scale. With the templet centered on the photograph, measure the remaining displacement  $d_t$  between the doubly-corrected templet position and the photograph image position. Also measure the radial distance  $r$  from the center of the photograph to the image. Assign a plus or minus sign to  $r$  according to whether the image is on the upper or lower side of the photograph, respectively—images are displaced inward on the upper side. Solve for the tilt of the photograph by substitution in equation 3432B

$$\sin t = \frac{fd_t}{r(1 + d_t)}$$

The approximate equation 3432D is usually of sufficient accuracy in which case the algebraic sign of  $r$  is not required

$$\sin t = \frac{fd_t}{r^2}$$

This completes the procedure.

*Example* The focal length of a photograph is 200 mm and the scale of a radial plot is 1/20,000. An image  $a$  (see fig. 340) near the apparent axis of tilt is 350 mm from the photograph center, the corresponding distance on the templet is 360 mm, and the object has an elevation of 100 feet. Another image  $b$  is on the lower side of the photograph near the apparent principal line 370 mm from the center, the templet distance is 350 mm, and the elevation of the object is 300 feet. What is the magnification ratio, the flying height, and the tilt of the photograph?

*Solution* Theoretical flying height of the templet and the radial plot is

$$H = \frac{200 \text{ mm}}{\frac{1}{20,000}} = 13,123 \text{ feet}$$

Relief displacement for  $a$ ,

$$d_a = \frac{360 \times 100}{13,123 - 100} = 2.8 \text{ mm}$$

Corrected radial distance for  $a$  on the templet,

$$r_t = 360 + 2.8 = 362.8 \text{ mm.}$$

Magnification ratio,

$$m = \frac{362.8}{350} = 1.03657$$

Flying height,

$$H_f = 13,123 \times 1.03657 = 13,503 \text{ feet above sea level}$$

Relief displacement for image  $b$ ,

$$d_b = \frac{350 \times 300}{13,123 - 300} = 8.2 \text{ mm}$$

Corrected radial distance for  $b$  for relief,

$$r_t = 350 + 8.2 = 358.2 \text{ mm}$$

Corrected radial distance for  $b$  for scale,

$$r_t' = \frac{358.2}{1.03657} = 345.6 \text{ mm}$$

Displacement of  $b$  due to tilt alone,

$$d_t = 370 - 345.6 = 24.4 \text{ mm}$$

Tilt of the photograph,

$$\sin t = \frac{24.4 \times 200}{(-370)(-370 + 24.4)} = 0.03816$$

$$t = 2^{\circ}11'$$

Using the approximate equation,

$$\sin t = \frac{24.4 \times 200}{370 \times 370} = 0.03565$$

$$t = 2^{\circ}03'$$

### 352 THE SCALE POINT METHOD

The scale point method of tilt determination is an approximate one which yields good results for small tilts and small elevation differences. This method is a variation of the "Anderson Method," which is named after R. O. Anderson (see footnote in 344) who developed it. This variation of the method is presented because it is sufficiently accurate and it is comparatively easy to understand in view of the geometric principles developed in section 34. Three scale-check lines are required—lines on the ground whose lengths are known and whose terminal elevations are known. The scale-check lines can consist of from three to six points of known relative positions and elevations.

The procedure utilizes the ideas of scale points, dropped perpendiculars, and rate of change in scale which were discussed in 344. The system is based on the absence of relief, which requires that the images be corrected by displacement of the images (3232), or by a method called "equivalent elevations" devised by Mr. Anderson, which is not presented here. Because of the fact that the rate of change in scale is uniform along any line, linear interpolation can be employed to find the scale at any point on a line through two points of known scale. If there are three scale points not on a line, then it is possible to find the scale at any other point on the photograph by not more than two interpolations. Also, if there are three scale points not on a line, by interpolation there can be located between the two points of largest and smallest values, a point that has the same value as the point of intermediate scale value. The line joining the intermediate point and the interpolated point is called a line of equal scale. But a line of equal or unvarying scale is parallel to the axis of tilt and perpendicular to the principal line. The principal line is then the perpendicular to the line of equal scale that passes through the principal point.

Any line that is perpendicular to the principal line is a line of equal scale, and the point of intersection of a perpendicular through a scale point with the principal line has

the same scale as the scale point. Thus, two or more scale points can be located on the principal line by merely dropping perpendiculars to it from other scale points. Then the rate of change of scale  $\frac{dS}{dy}$  can be determined by dividing the difference in the scale values of two points on the principal line by the distance between them. The relation of the tilt to the rate of change in scale is shown by equation 3441C.

Experience indicates that the accuracy of the results for nine-lens photographs is about  $\pm 3$  minutes in tilt,  $\pm 5^\circ$  in swing, and  $\pm 1$  percent in flying height, and that for single-lens 9- by 9-inch photographs it is about  $\pm 10$  minutes in tilt,  $\pm 10^\circ$  in swing, and  $\pm 1.5$  percent in flying height, although the proponents of the Anderson Method claim much better results. The errors are due principally to unavoidable discrepancies in measuring distances on the photographs, to differential shrinkage in the photographic materials, to the graphic construction, and to the theoretical approximations of the method. The first two causes of error are by far the most important.

The procedure is outlined by a series of steps and is illustrated with an example.

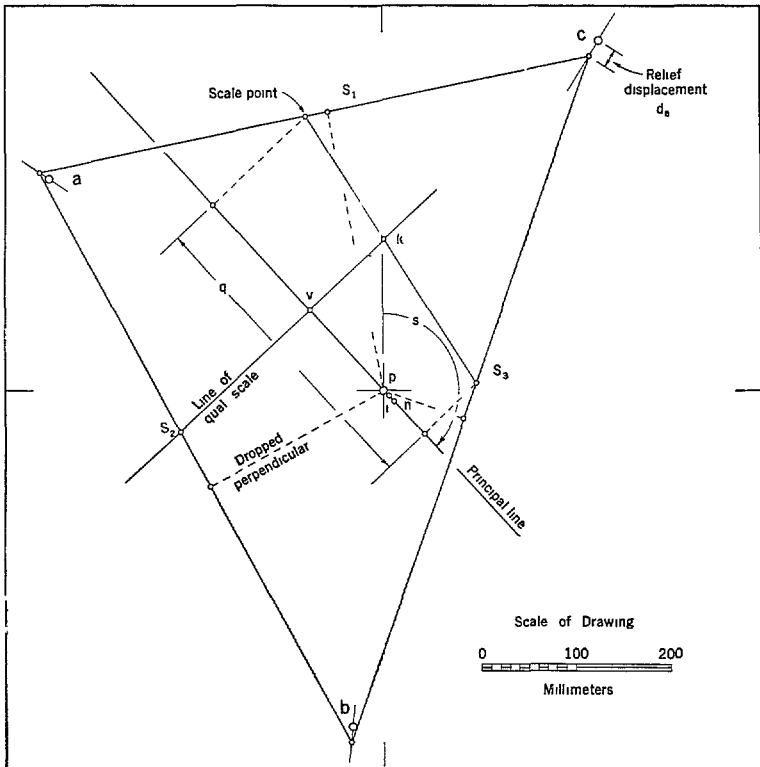

FIGURE 3 41 —Example of scale point method of tilt determination

1 Select three scale-check lines that are spaced somewhat uniformly about the center of the photograph. Record the ground length  $AB$  (see fig 3 41) for each scale-check line and the elevation  $h$  at each end of each scale-check line.

2 Select a datum elevation midway between the stations of highest and lowest elevations. (If the elevation differences are relatively small—less than 200 feet—select the elevation of the station of

intermediate elevation as the datum elevation) Displace each of the images toward or away from the principal point  $p$  a distance  $d_o$

$$d_o = \frac{rh}{H}$$

where  $r$  is the radial distance from the principal point to an image of one end of a scale-check line,  $h$  is the difference in elevation between the datum elevation and the elevation of the end of the scale-check line, and  $H$  is the best known value for the flying height

3 Measure and record the photograph length  $ab$  of each scale-check line after the ends have been displaced for their elevations

4 Compute a scale number  $S$  for each line

$$S = \frac{ab}{AB}$$

Designate the scale numbers  $S_1$ ,  $S_2$ , and  $S_3$  in increasing order of the magnitudes of their numbers It is more convenient to divide the scaled distance number  $ab$  in whatever units it is measured by the ground distance number  $AB$  in whatever units it is given, without any conversion of units, and to move the decimal point in the quotient by applying the notation  $\times 10^{-6}$ , or whatever other power is appropriate Each of the scale numbers is then a whole number of five digits having a common multiplier This is a logical short cut that does not affect the result

5 Determine the position of the scale point graphically for each of the scale-check lines using the dropped perpendicular method explained in 3442 Label the scale points  $S_1$ ,  $S_2$ , and  $S_3$  according to step 4

6 Draw the line  $S_1S_2$  and measure its length  $l$

7 Compute by direct proportion the distance from  $S_1$  to  $k$  on the line  $S_1S_3$  such that the scale value at  $k$  is equal to  $S$ .

$$S_1k = \frac{l(S_2 - S_1)}{S_3 - S_1}$$

8 Locate the point  $k$  and draw the line  $S_2k$  This is a line of equal scale

9 Construct a line through the principal point  $p$  perpendicular to the line of equal scale This is the principal line The angle of swing can be measured now if it is required, using the definition in 3462.

10 Construct perpendiculars from  $S_2$  and  $S_3$  to the principal line and measure the distance  $q$  between them

11 Compute the angle of tilt

$$\sin t = \frac{H(S_3 - S_1)}{q} \times 10^{-6}$$

This is a form of equation 3441C where

$$\frac{dS}{dy} = \frac{S_3 - S_1}{q}$$

12 Determine the distances  $pn$  and  $pv$  to the nadir point and the isocenter, respectively, and locate them on the principal line so that  $n$  is on the side of  $p$  having the greater scale value These approximate equations can be used

$$pn \approx f \sin t$$

$$pv \approx \frac{1}{2} pn$$

13 If a more nearly correct value for the flying height is desired, the scale number at the isocenter of the photograph is needed Measure the distance  $v_i$  on the principal line from the line of equal scale to the isocenter Compute the scale at the isocenter from

$$S_v = S_2 \pm (v_i) \frac{dS}{dy} = S_2 \pm (v_i) \frac{S_3 - S_1}{q}$$

The algebraic sign is positive if the scale numbers increase in the direction from  $v$  to  $i$  as indicated by the relative positions of the scale points

14 Compute the flying height from

$$H = \frac{f}{S_v} \times 10^6$$

The flying height is then in the same units as the ground distances. The logic of this step should be noted—the scale at the isocenter is also the scale of the equivalent vertical photograph.

15 A second solution should always be performed as a check if for no other reason. Subsequent solutions are not necessary if the results of two solutions differ by less than five minutes in tilt. The following changes should be observed in the second and subsequent solutions:

(a) Use the nadir point instead of the principal point for measuring the radial distances and making the displacements in step 2.

(b) Use the isocenter instead of the principal point as the origin for the dropped perpendiculars in step 5.

(c) Use the value of  $H$  from step 14 for computing the relief displacements of step 2.

*Example* (See figure 3.41) The given data include the image coordinates on a nine-lens photograph. It is suggested that the student perform the solution independently.

Given Three connected scale-check lines forming a triangle

Lengths	$AB = 22166$ feet	Elevations	$A = 107$ feet
	$BC = 23510$		$B = 0$
	$CA = 20589$		$C = 611$

Focal length = 209.7 mm  
 Estimated flying height = 6875 feet

Image coordinates (usually not measured but given here in the event the reader wishes to plot the points and perform the solution)

	$x$	$y$
$a$	-353.59 mm	+220.79 mm
$b$	-33.20	-355.02
$c$	+231.09	+363.83

*Solution* The graphic construction can be performed on the face of the photograph, on an overlay, or on the back of the photograph by pricking the four salient points through the paper.

STEP 2 Mid elevation datum = 305 feet

Flying height above datum = 6875 - 305 = 6570 feet

	$r$	$h$	$d_a = \frac{rh}{H}$
$a$	416.9 mm	-198 ft	-12.6 mm
$b$	356.6	-305	-16.6
$c$	431.0	+306	+20.1

The displacements were made as shown:  $a$  and  $b$  outward and  $c$  inward. The scale points were then located graphically.

STEPS 3 AND 4

	$d$	$S \times 10^{-6}$
$ab$	683.6	30840 $S_2$
$bc$	762.3	32425 $S_3$
$ca$	596.7	28981 $S_1$

$S_3 - S_1 = 3444$   
 $S_2 - S_1 = 1859$

$S_2 = 683.6 - 22166 = 30840 \times 10^{-6}$

STEP 6  $S_1 S_3 = j = 334.0$  mm

STEP 7  $S_1 h = 334.0 \times 1859 - 3444 = 180.3$  mm

STEP 10  $q = 332.9$  mm

STEP 11  $\sin t = 10^{-6} \times 6570 \times 3444 - 332.9 = 0.06797$   
 $t = 3^\circ 53' 8''$

STEP 12  $pn = 209.7 \times 0.06797 = 14.25$  mm  
 $p_1 = 0.5 \times 14.25 = 7.13$  mm

The following steps are usually not required.

STEP 13  $v_1 = 104.6$  mm

$S_1 = 30840 + (104.6 \times 10.35) = 31922$

where  $(S_3 - S_1) - q = 10.35$

STEP 14  $H = 209.7 - (31922 \times 10^{-6}) = 6569$  feet above datum  
 $H = 6569 + 305 = 6874$  feet above sea level

This completes the initial solution. A second solution resulted in the values

$$\begin{aligned}t &= 4^{\circ}01'2, \\H &= 6880 \text{ feet}\end{aligned}$$

The correct values are known to be  $t = 4^{\circ}09'0$  and  $H = 6791$  feet. The errors are quite characteristic of this method.

### 353 OTHER METHODS OF TILT DETERMINATION

The literature on the subject of photogrammetry contains numerous methods of tilt determination. Outstanding among the many methods—because of their extremely fundamental mathematical approach and the complete absence of numerical approximations—are those devised by Professor Earl Church of Syracuse University. These methods are not presented in detail here because to do so would merely be a repetition of published material. These methods are not used very much in mapping because of the long time required to make the necessary computations and the lack of experience in applying them, but the methods *are* used in research work where the results of a study must not be affected by any inaccuracies of the methods used. Most of these methods yield results that are exactly consistent with the accuracy of the given data. If one were to streamline the methods for more rapid computation, he would possibly arrive at some approximation comparable in accuracy to the Scale Point Method.

The Church methods were possibly developed not only as devices for teaching the mathematical behavior of photogrammetric procedures, but also with the thought that (a) the methods might be employed for the extension, bridging, and distribution of control with an accuracy equivalent to that of the most precise stereoscopic plotting instrument, (b) accurate rectification data and pass points could be computed, and (c) rectified photographs could be compiled with a comparatively simple instrument. So far as known by this writer, no large mapping project has been completed in this manner.

The Church methods are based on the coordinate measurements of certain images on the photographs. To be most accurate, the photographs should presumably be taken with a glass plate camera, and a complete analysis should be made of the lens characteristics so as to be able to apply distortion corrections to the coordinate measurements. It seems apparent that a comparator would be required with which the coordinates could be measured within a tolerance of  $\pm 0.01$  mm *while the images were being viewed stereoscopically*. The methods would then enable the photogrammetrist to compute all the positions and elevations that are ordinarily obtained by radial plotting, multiplex apparatus, or stereoplanigraph.

#### 3531 Scale Data from Two Photographs

Of significance is a bulletin entitled *Determination of Scale Data for Two Aerial Photographs from One Control Line and Three Additional Elevations* by Professor Church. The control line is considered as being determined by two ground stations whose elevations and the horizontal distance between them are known. The scale data for a photograph consist of the tilt, swing, and flying height, or other equivalent related factors such as  $x$ -tilt,  $y$ -tilt, and scale. The method is one of successive approximations that results in any desired degree of tolerance. The type of computation consists of repeated solutions of the fundamental problems shown in 3271, 3272, and 3461 to 3464, together with the solutions of four simultaneous linear equations in four unknowns. The first four problems are computed about ten times and the simultaneous equations about three times. The solution is rather long, but none of the operations is very involved. The solution also yields the correct ground distances between the additional points of known elevations.

### 3531A *Special Case if Distance is Unknown*

It is interesting to note that the method (3531) can still be performed without the known ground distance, which can be assumed to be a logical value, or even any round number, such as 10,000. The resulting flying heights and distances would thence be in error in the same proportion that the assumed distance was in error, all of which could be corrected later when the required correct information is obtained, or when two horizontal control points are eventually encountered in the same flight line. Thus the *exact* tilt and a *relative* flying height of each one of a strip of photographs can be determined by this method if only the elevations of five well-distributed objects in each overlap area are known, such points consisting possibly of sea level objects along an irregular shoreline.

### 3531B *Adaptation to a Single Photograph*

The writer has adapted this same type of solution to a single photograph using three control lines, connected or disconnected. Obviously, the solution is very much shorter than that of 3531. The adaptation consists of about six solutions of the fundamental problems and three solutions of simultaneous equations in two unknowns. This method is perhaps the shortest and simplest precise one to date for finding the three elements of the scale data from a single photograph.

### 3532 *A Simplified Method*

Professor Church has also developed a *Precise Determination of the Tilt of An Aerial Photograph, (Simplified Method)* which is somewhat similar to 3531B, but which is an extremely brief computation resulting from the many short cuts employed. The method enables one to determine directly the  $x$ -tilt and  $y$ -tilt from which the resultant tilt can be evaluated if needed. The exact flying height is not determined in the solution, but obviously it could be computed, if needed after the tilt data are known. Successive approximations are not used in the method—it is assumed that the initial solution of the simultaneous equations in two unknowns yields a result of sufficient accuracy.

### 3533 *Tilt Data from Elevations Alone*

Another type of solution of the problem 3531A was introduced by Professor Church in Photogrammetric Engineering for September 1947. The required ground control consists only of four well-distributed *vertical* control points in each model. The computation is performed for two photographs simultaneously and yields the tilt data for both photographs. The method of solution uses the principles of direction cosines. This solution is somewhat shorter than 3531A and yields the same data but is somewhat more complex in theory.

### 3534 *The Complete Space Solutions*

A complete solution of the aerial photograph consists of determining six elements, three of which are linear and three are angular—the  $X$  and  $Y$  geographic position coordinates of the camera perspective center at the instant of exposure, the  $Z$  position coordinate (exact flying height), the tilt and swing elements of the photograph, and a geographic orientation element which is expressed as the azimuth of the principal plane. All these can be determined with the use of a solution presented by Professor Church in a bulletin entitled *Revised Geometry of the Aerial Photograph*. The solution itself is divided into

two parts—Space Resection and Space Orientation, in addition to other solutions for utilizing the determined data. By the first part it is possible to determine the three linear position elements by successive approximations, using the cosines of the face angles of the photographic pyramid, which angles are not affected by the tilt of the photograph (see 347). The required data consist of geographic plane coordinate positions and elevations of three well-distributed stations. The solution is based on fundamental principles of the solid analytic geometry of lines, planes, and angles, and in the second part are used the principles of the transformation of coordinates in a three-dimensional system as applied to a rotation of the axes. The formulas for determining the coefficients of the simultaneous equations are derived by partial differential calculus. The second part of the computation—space orientation—is direct and consists of only the solution of three simultaneous equations in three unknowns, the coefficients for which are all determined in Space Resection. The complete solution is not so long as might be expected—it is considerably shorter than that of 3531 or 3533. The computation can readily be placed on a single page form on which is sufficient space for three adjustments to the successive approximations and the complete solutions of all the simultaneous equations in three unknowns. The computation can be performed without an understanding of the fundamental principles. A by-product of the computations is a list of nine direction cosines in a convenient form for use in further computations, such as those of 3534A and B.

#### *3534A Space Intersection*

The geographic coordinates and the elevation can be determined for any object whose image appears in the overlap area of two photographs for which the solutions of 3534 have been completed. The method is described and illustrated in the bulletin referred to in 3534. The solution is short and direct.

#### *3534B Space Intersection, Elevations Known*

The geographic coordinates can be determined for any object of known elevation if the image appears on a single photograph for which the solutions of 3534 have been completed. This method is described in the same reference indicated in 3534. The solution is more direct and shorter than that in 3534A.

#### *3534C Control Extension*

A method is also described in the bulletin referred to in 3534 by which it is possible to continue to determine the elements of space resection and space orientation throughout a strip of photographs where the ground control occurs only in the overlap area of the first two. The computation is somewhat long, and it is indicated that the solution is not necessarily practical. The solution does serve as a mathematical justification for similar optical-graphical solutions with stereoscopic plotting instruments. The solution is greatly simplified if known vertical control points are strategically located in each overlap area. The solution is then quite comparable to the instrumental procedures in which an elevation is required in each of the four corners of each overlap area. In fact, small-scale and reconnaissance maps are about the only types of maps that can be made from photographs by any known method without ground control.



3535 *A Method by Professor Marsten Morse*

A direct method for the determination of the tilt data for a single photograph has been devised by Professor Marsten Morse of Princeton University, but it has not been published. The method requires one horizontal control point at or near the center of the photograph in addition to the usual three well-distributed horizontal and vertical control points of nearly equal elevation. The solution is very easily adapted to a larger number of outer control points. In practice the results are not seriously affected if the central point is approximately one-half inch from the principal point, or if the other control points are not exactly of equal elevation. If there is a difference in elevation such that the difference in relief displacement might influence the tilt determination, then some of the images can be displaced for relief. The  $X$  and  $Y$  ground coordinates of the control stations in any system are required as are the coordinates of the images on the photograph. The method is based on the differences in the ratios of the areas of the central triangles formed by the images relative to those formed by the ground stations. The computation is quite short and extremely methodical. The solution is exact if the special conditions exist, and the error is perhaps of the order of 10 minutes if the conditions are only approximately met.

36. RECTIFICATION<sup>5</sup>

Rectification is the operation by which tilt displacements are removed from tilted photographs. In other words, simple rectification produces from a tilted photograph one which would have been obtained from the same perspective center if the camera had not been tilted. However, the word is more often used to imply also a simultaneous change in photographic scale, in which case a photograph is produced that would have been obtained from the same perspective center with an untilted camera having a different focal length.

A rectifying camera (rectifier) is a photographic instrument used to perform rectification. It resembles an enlarging camera with special means provided for tilting the negative, lens, and easel, in addition to the usual means for varying the two optical distances. Accordingly, there are five separate motions on a rectifying camera which can be varied independently and which are designated as follows (see figure 3 42)

- 1 Inclination of the negative,  $N$
- 2 Inclination of the easel,  $S$
- 3 Inclination or cant of the lens,  $c$
- 4 Distance from the lens to the negative on the line of centers,  $Lp$ , or on the optical axis,  $Le$
- 5 Distance from the lens to the easel on the line of centers,  $LP$ , or on the optical axis,  $LE$

The five variable quantities are rigidly and uniquely related to four constant quantities for a given photograph in order (a) to obtain a geometrically true perspective photograph having no tilt and having a desired scale, and (b) to maintain sharp image definition over the entire photograph. The constant quantities are

- 1 Tilt of the aerial camera,  $t$
- 2 Desired magnification ratio,  $m$
- 3 Focal length of the aerial camera,  $f$
- 4 Focal length of the rectifier lens,  $g$

<sup>5</sup> Hotine, M., *Surveying from Air Photographs*, chapter 5

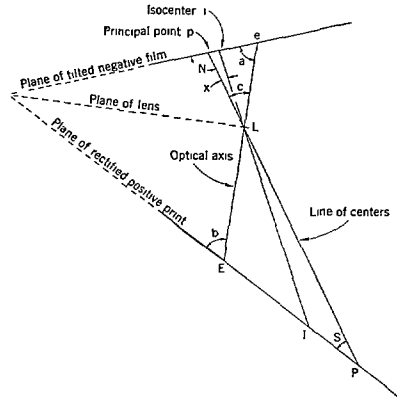

FIGURE 3 42—Elements of rectification

The relation of the five variables to the four constants that will maintain the correct optical and geometric conditions are given by the following algebraic equations whose derivations are shown in 364.

$$\cos b = \frac{g \sin t}{f} \quad (36A)$$

$$\cos a = \frac{g \sin t}{mf} \quad (36B)$$

$$\tan x = \tan \frac{a+b}{2} \tan^2 \frac{t}{2} \quad (36C)$$

$$N = \frac{a+b}{2} + x \quad (36D)$$

$$S = \frac{a+b}{2} - x \quad (36E)$$

$$c = N - a \quad (\text{Also } c = b - S) \quad (36F)$$

$$Lp = \frac{g \sin (a+b)}{\sin N \cos b} \quad (36G)$$

$$LP = \frac{g \sin (a+b)}{\sin S \cos a} \quad (36H)$$

$$Le = \frac{g \sin (a+b)}{\sin a \cos b} \quad (36I)$$

$$LE = \frac{g \sin (a+b)}{\sin b \cos a} \quad (36J)$$

$$pe = \frac{f}{\sin t} \left( \frac{\sin b}{\sin a} - \cos t \right) \quad (36K)$$

Rectifiers produced by different manufacturers do not necessarily use the same reference axes. Accordingly, the five settings do not always involve the same quantities although the *relative* positions and inclinations of all the elements are the same, respectively. The five settings given by equations 36D, E, F, G, and H refer to the line of centers or the principal point line as the reference line. The line of centers is maintained vertical in the rectifier of the Coast and Geodetic Survey and is the principal reference line. However,

the optical axis is often used as the line of reference for which the settings are given by equations  $36A, B, I, J,$  and  $K$ . In a similar manner other systems can be employed, such as

- (a) One in which the negative plane is maintained vertical
- (b) One in which all the settings are referred to the horizontal easel plane
- (c) A rectifying projector that uses oblique photographs in a vertical position with a mirror for projecting a rectified positive image onto a horizontal drafting surface
- (d) A camera for photographing a map in horizontal position to cause it to resemble an oblique view

The rigid maintenance of the foregoing relations can be regarded as *precise* rectification such as must be observed for making photographs to be used for drawing contours with a stereoscopic plotting instrument. Obviously, the conditions must be observed in the design of rectifying instruments.

If the values of  $t$  and  $m$  are not known, precise rectification can also be performed in a graphic manner using successive adjustments of the settings leading eventually to properly related settings together with a satisfactory fitting of images to predetermined positions.

Approximate rectification is used to some extent in connection with the making of mosaics and radial plotting. Sometimes no effort is made to determine the settings, but arbitrary adjustments are made until the images fit prescribed positions and image sharpness is maintained visually by canting the lens and using a small lens opening.

An automatic rectifying camera is one that coordinates the various motions of the instrument by mechanical devices so that when one setting is made, the other settings are adjusted simultaneously to maintain the correct optical and geometric conditions. A manually operated rectifying camera is one in which the motions are not interconnected in any manner and each of the motions must be set individually to maintain the desired conditions. The rectifier of the Coast and Geodetic Survey that is used for nine-lens photographs is essentially manually operated although it has an automatic focusing mechanism for the condition of no tilt.

The word "transformation" is frequently used synonymously with rectification. Rectification is truly an optical method for systematically changing the positions and orientations of lines between images so that all straight lines are reproduced as straight lines, which is called "linear transformation" in mathematics. General usage, however, has confined the meaning of transformation to the special procedure of rectifying an oblique view into a fixed or predetermined orientation. Consequently, the transformer of the Coast and Geodetic Survey is the instrument for mechanically changing the original film of the nine-lens camera (which consists of one near-vertical photograph and eight oblique photographs) into one composite near-vertical photograph, and a rectifier is used to change the near-vertical photograph to a true-vertical photograph by a second and entirely separate photographic step.

The remainder of this section is devoted to the consideration of the theory of rectification, the derivation of the equations already given, and to the applications of the theory to the nine-lens equipment of the Coast and Geodetic Survey.

### 361. CONDITION OF SHARP DEFINITION

Sharp image definition is one of the two conditions that must be maintained in precise rectification. It is to be shown that if one image is in sharp focus in an optical system, then all images are in sharp focus if the planes of the object, the image and the lens intersect on a common line. (Parallel planes are considered as intersecting on a common line at infinity.) This is known as the Schempflug condition.

If an optical image is to be in sharp focus, the sum of the reciprocals of the object and image distances must be equal to a specified constant which is the reciprocal of the focal length of the lens (see 315) Inasmuch as a lens has a single focal length, the condition for two or more images to be in sharp focus simultaneously is that the sum of the reciprocals of the object and image distances must be equal for each object-image pair The object and image distances are measured on, or parallel to, the lens axis

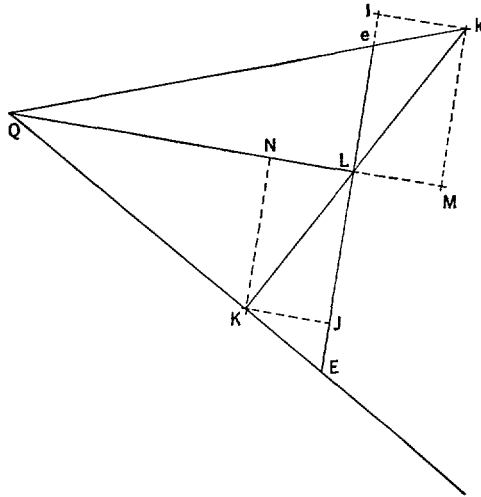

FIGURE 3 43 —The Schemppflug condition

In Figure 3 43,  $QK$  represents the object plane,  $Qk$  represents the image plane, and  $QL$  represents the lens plane where each of the planes is perpendicular to the plane of the page The lens axis  $eLE$  is perpendicular to  $QL$  Let  $e$  be the sharp focus image of  $E$  and let  $k$  lie in the image plane and on the line  $KL$  extended It is to be shown that  $k$  is also the sharp focus image of any point  $K$  in the object plane if the three planes intersect in a line at  $Q$

Construct  $kj$  perpendicular to  $Le$  extended,  $kM$  perpendicular to  $QL$  extended,  $KJ$  perpendicular to  $LE$ , and  $KN$  perpendicular to  $QL$  Then the object distance for  $K$  is  $JL$  and the corresponding image distance for  $k$  is  $jL$  and the proof consists in showing that

$$\frac{1}{jL} + \frac{1}{jL} = \frac{1}{eL} + \frac{1}{EL} \tag{361A}$$

which assures that  $k$  is the sharp focus image of  $K$  if  $e$  is the sharp focus image of  $E$

In the similar right triangles  $QLe$  and  $QMk$ ,

$$\frac{QM}{kM} = \frac{QL}{eL} \tag{361B}$$

and in the similar right triangles  $QLE$  and  $QNK$ ,

$$\frac{QN}{KN} = \frac{QL}{EL} \tag{361C}$$

Adding equations 361B and C,

$$\frac{QM}{kM} + \frac{QN}{KN} = \frac{QL}{eL} + \frac{QL}{EL}.$$

But,

$$kM = jL, KN = JL, QM = QL + LM, QN = QL - LN,$$

Then by substitution,

$$\begin{aligned} \frac{QL + LM}{jL} + \frac{QL - LN}{JL} &= \frac{QL}{eL} + \frac{QL}{EL} \\ \frac{QL}{jL} + \frac{LM}{jL} + \frac{QL}{JL} - \frac{LN}{JL} &= \frac{QL}{eL} + \frac{QL}{EL}. \end{aligned} \tag{361D}$$

But in the similar right triangles  $Ljk$  and  $LJK$ ,

$$\frac{jk}{jL} = \frac{JK}{JL}.$$

By construction  $jk = LM$  and  $JK = LN$ , and

$$\frac{LM}{jL} = \frac{LN}{JL}.$$

Equation 361D then becomes

$$\frac{QL}{jL} + \frac{QL}{JL} = \frac{QL}{eL} + \frac{QL}{EL}. \tag{361E}$$

Equation 361A results from 361E by dividing each term by  $QL$ , and the principle is proved

It is also quite obvious that the object distance is not changed if  $K$  lies anywhere on the line that is perpendicular to both  $QK$  and  $LK$  at  $K$ . Hence the proof is valid for all object positions in the object plane

### 362. FOCAL LENGTH OF A RECTIFIER LENS

The focal length  $g$  of a lens that is used in a rectifier is a definite dimension in the geometric diagram of the rectifier if the condition for sharp focus exists (see 361). The value can be exhibited by geometric construction (figure 344) where  $TV = g$  is the

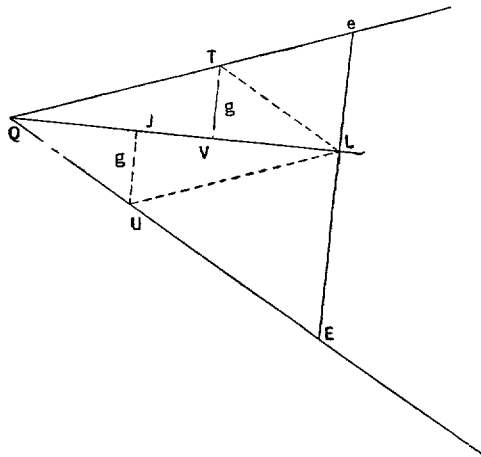

FIGURE 344—The focal length of a rectifier lens

required dimension and the focal length of the rectifier lens,  $TV$  is perpendicular to  $QL$ , and  $LT$  is parallel to  $QE$ . The principle is used in the derivation of rectification formulas.

The line  $LU$  is constructed parallel to  $Qe$ , and  $UJ$  is constructed perpendicular to  $QL$ . (The point  $T$  is called the horizon point or the image of the horizon on the negative film of a tilted photograph where the line  $QE$  is the horizontal ground surface. The point  $U$  is analogous to  $T$ .)

It is necessary to show that the distance  $TV$  is the quantity whose reciprocal is always equal to the sum of the reciprocals of the object and image distances because this relation assures the condition of sharp focus.

$$\frac{1}{TV} = \frac{1}{eL} + \frac{1}{EL}. \quad (362A)$$

It should be kept in mind that the dimensions  $eL$  and  $EL$  are variable, but so long as they satisfy the simple lens law,  $TV$  is the required length.

In the similar right triangles  $QLe$  and  $QVT$ ,

$$\frac{QV}{TV} = \frac{QL}{eL}. \quad (362B)$$

And in the similar right triangles  $QLE$  and  $QJU$ ,

$$\frac{QJ}{UJ} = \frac{QL}{EL}. \quad (362C)$$

Adding 362B and C,

$$\frac{QV}{TV} + \frac{QJ}{UJ} = \frac{QL}{eL} + \frac{QL}{EL}. \quad (362D)$$

But triangles  $QVT$  and  $LJU$  are congruent because they are similar right triangles and because  $QT = LU$  by construction. Then  $TV = UJ$ , and equation 362D becomes

$$\frac{QK + QJ}{TV} = \frac{QL}{eL} + \frac{QL}{EL}. \quad (362E)$$

Line  $QV = LJ$  because they are also corresponding sides of the congruent triangles  $QVT$  and  $LJU$ . Then  $QV + QJ = QL$ , and

$$\frac{QL}{TV} = \frac{QL}{eL} + \frac{QL}{EL}. \quad (362F)$$

Equation 362A is derived by dividing each side of 362F by  $QL$ . The principle is then proved.

### 363 THE PARALLELOGRAM PRINCIPLE

If a line intersects the sides, or their extensions, of a parallelogram, the points of intersection remain in a straight line under any *angular* deformation of the parallelogram. The principle is exemplified in the common pantograph, and is of prime importance in the theory of rectification.

Let  $QTLU$  (see fig. 3.45) be a parallelogram. Let  $kLK$  be any line that intersects the sides of the parallelogram at the points  $k, L, L, K$ , where  $L$  occupies the dual role of being a point on both of the sides  $TL$  and  $UL$ . (Although the theorem is perfectly general, the proof is cited for this special application only.) The point  $L$  can be considered as the position of the lens of a rectifier,  $K$  any image point on the easel plane, and  $k$  the corresponding object point in the negative plane. The theorem states that if the three points  $k, L$ , and

$K$  are on a line and if the angle at  $Q$ , for example, is changed along with other necessary angular changes without altering any of the lengths of the lines other than  $KL$  and  $kL$ , then the three points will remain on a line. Hence, under these conditions, a ray of light from  $k'$  through a lens point  $L'$  will always intersect the plane  $QK$  at exactly the same position  $K$ . Such an angular change might well be made to accommodate any convenient dimension  $g$  (362) which would change only the angular relations of points on the negative, lens, and easel planes without disturbing their positions relative to the point  $Q$ .

In the figure the angle  $a$  at  $Q$  is changed by the amount  $d$  so that  $k$  is moved to  $k'$ ,  $L$  to  $L'$ , etc. The principle is proved by showing that the line  $KLk'$  is a straight line because the angle at  $L'$  between  $K$  and  $k'$  is  $180^\circ$ .

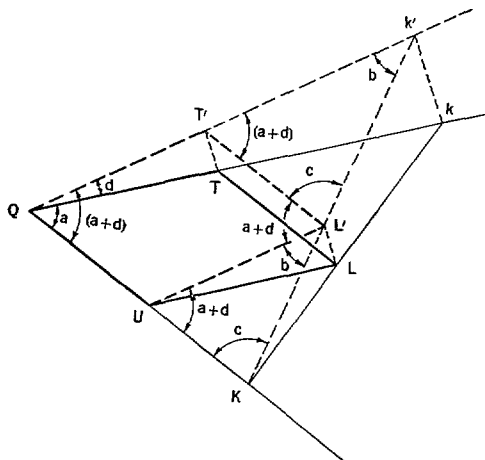

FIGURE 3.45 —The parallelogram principle

Triangles  $kTL$  and  $LUK$  are similar because their sides are respectively parallel due to the parallelogram construction. The quadrilateral  $QT'L'U$  is also a parallelogram because the lengths of its sides are not changed from those of the original parallelogram. The line  $QT'k'$  also remains a straight line because it is a side, extended, of the original parallelogram. Then

$$\text{angle } k'QK = k'T'L' = L'UK = T'L'U = a + d$$

because they are corresponding angles formed by systems of parallel lines. Triangles  $k'T'L'$  and  $L'UK$  are then also similar because the ratios of two pairs of their sides have not been changed from those of the original triangles, and because the included angles are equal. Let

$$\begin{aligned} \text{angle } b &= T'k'L' = UL'K \\ \text{angle } c &= L'KU = k'L'T' \end{aligned}$$

Then the sum of the angles at  $L' = a + b + c + d$

which is exactly the same as the sum of the angles of triangle  $k'T'L'$  or  $180^\circ$ . Hence the line  $KLk'$  is a straight line and the proof is complete.

It should be noted, incidentally, that  $k$  and  $k'$  lie on the arc of a circle whose center is at  $Q$ , which relation also exists for the points  $L$  and  $L'$ , and  $T$  and  $T'$ .

364 DERIVATION OF FORMULAS

The geometry of the problem of rectification is demonstrated with reference to figure 3 46A and B The theoretical analysis shown by figure 3 46A indicates what must be accomplished by the practical optical step illustrated in figure 3 46B This analysis yields the rectification equations 36A to K by using the principles of the preceding sections

A - The light rays are directed back through the lens in exactly the opposite directions as at the time of exposure and the points K, P, I, N are obviously in their correct rectified positions, but an impractical short focal length  $g$  is required at O to give sharp focus

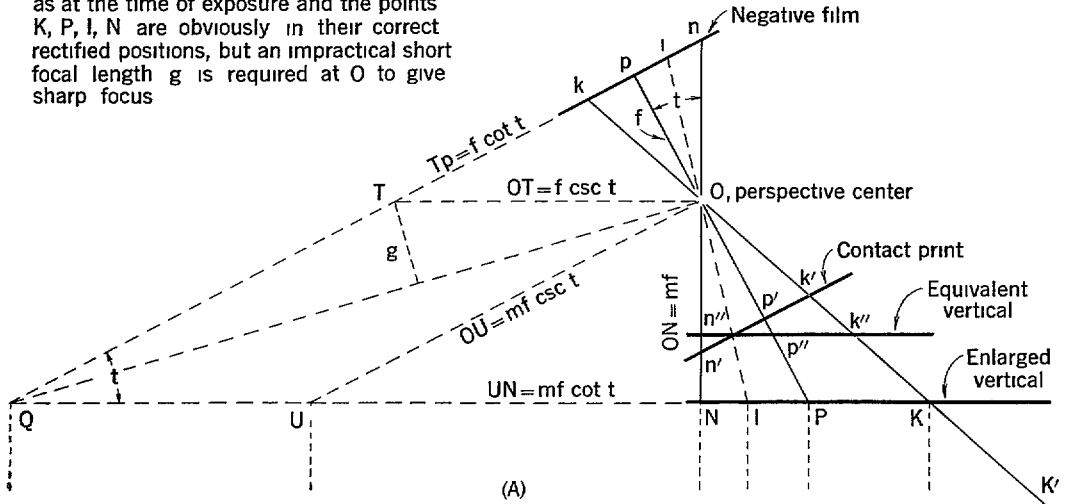

B - A more convenient value for  $g$  may be used by merely "opening" the planes, which retains exactly the same positions K, P, I, N and also retains sharp focus

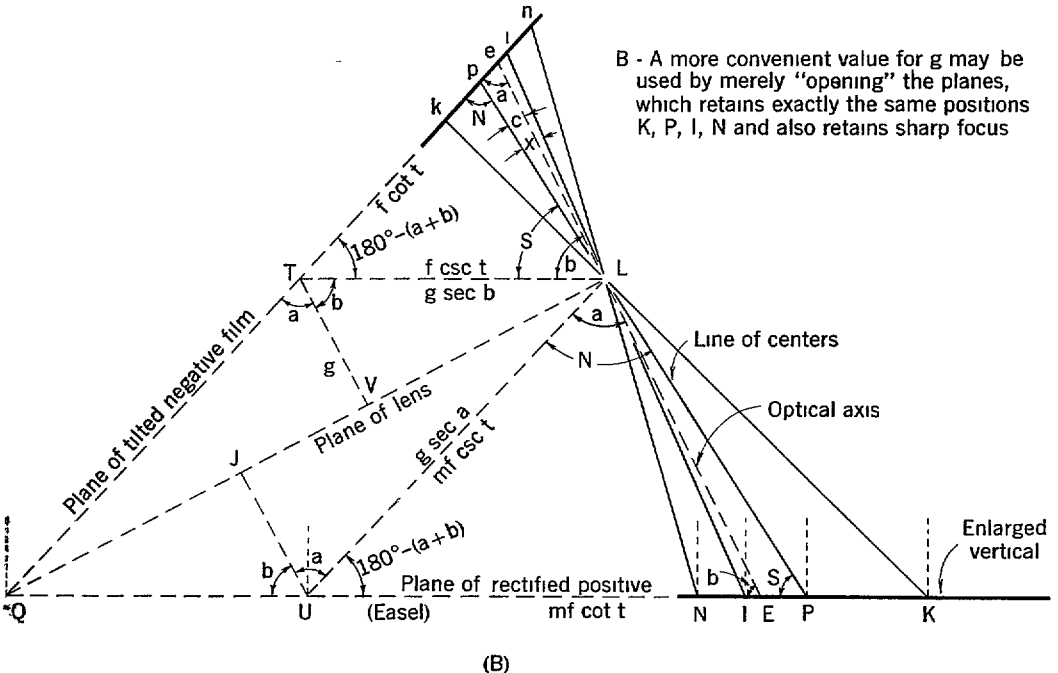

FIGURE 3 46 —Theoretical and practical rectification



Let  $K'$  be any object point on the ground acting as a source of a light ray passing through the aerial camera lens at  $O$  (focal length  $Op = f$ ) to the image point  $k$  on the tilted negative film. Figure 3 46A shows the lens point and the film in the same angular orientation they had at the moment of exposure where the line  $QK$  is a truly horizontal line. In rectification the image points like  $k$  are illuminated and thus projected through  $O$  in the direction of  $K'$  but intercepted by sensitive photographic paper at the easel plane  $QK$ . Let  $n$  represent the nadir point on the negative, and the angle of tilt is  $pOn = t$ . The position of the image on either a contact print or on a one-to-one ratio print can be represented by  $k'$  where  $Op' = f$  in the same manner that is used in 3221. The position of the image  $k''$  is on an *untilted* photograph made at  $O$  with a camera of the same focal length, and this photograph plane is the equivalent vertical photograph.

The point  $K$  is then the correct position of the image of  $K'$  on an untilted photograph taken at  $O$  with a camera of focal length  $ON = mf$ , where  $m$  is the necessary factor of magnification to create the equality. It is this image position  $K$  that must be produced and maintained for each image by rectification. In other words, if all the negative images like  $k$  are transformed into new positions like  $K$ , then rectification will be correct and complete so far as the *positions* of images are concerned.

Figure 3 46A illustrates what might be called "geometric" rectification. It indicates the final product but does not necessarily show how it is to be obtained "optically" in practice. In most cases it would not be physically possible to duplicate a system like the figure by an optical method. The short focal length  $g$  required for creating sharp focus at  $K$  might prove to be impracticable from the standpoint of optical design for the necessary angular coverage. For example, the aerial camera lens at  $O$  is usually as short a focal length and as wide an angle as it is possible to design, but to satisfy the condition of sharp focus in figure 3 46A would require a focal length shorter even than  $f$  and an angle wider than that of the taking camera. However, it is shown in 363 that if the angle at  $Q$  is allowed to change as in figure 3 46B, the rectifier lens focal length  $g$  also changes, the positions of the negative points  $k$ ,  $p$ ,  $v$ , and  $n$  remain fixed with respect to  $Q$ , the dimensions of the parallelogram  $QTLU$  remain constant, the positions of the image points on the easel occur at  $K$ ,  $P$ ,  $I$ , and  $N$ , the exact places which they would occupy by geometric rectification, and furthermore, all the images are also in sharp focus (361).

The discussion has considered only those points that lie on the principal line, but the principles are valid for all points anywhere on the negative and easel planes. It is indicated in 361 that the condition for sharp focus is valid for all points. It is also pointed out in 3424 that any point on a photograph can be considered as lying on a line through the principal point, and this line can be regarded just like a principal line but of a photograph having a different but definite tilt  $t'$ . Thus, without formal proof, it is evident that if the correct geometric and optical conditions for rectification exist on the principal line, then they also exist over the entire area of the photograph.

The construction and symbols in the figures are the same as used in the foregoing headings. In the right triangle  $TpO$  of figure 3 46A,

$$Tp = f \cot t \quad (364A)$$

$$TO = f - \sin t = f \csc t \quad (364B)$$

In the right triangle  $UNO$ ,

$$UN = mf \cot t \quad (364C)$$

$$UO = mf \csc t. \quad (364D)$$

In the right triangle  $TVL$  of figure 3 46B

$$\cos b = \frac{TV}{TL} = \frac{g}{f \csc t} = \frac{g \sin t}{f} \quad (36A)$$

and in the right triangle  $UJL$ ,

$$\cos a = \frac{UJ}{UL} = \frac{g}{mf \csc t} = \frac{g \sin t}{mf} \quad (36B)$$

because the dimensions of the sides of the parallelogram are respectively equal in the two figures

In the oblique triangle  $eLT$ , angle  $eLT = b$ , and by the law of sines of trigonometry,

$$\frac{eL}{\sin [180^\circ - (a + b)]} = \frac{LT}{\sin a} \quad (364E)$$

Because it is evident from equation 36A that  $LT = g \sec b$ , and because in trigonometry the sine of an angle is equal to the sine of the complementary angle, and if equation 364E is solved for  $eL$ ,

$$eL = \frac{g \sec b \sin (a + b)}{\sin a} = \frac{g \sin (a + b)}{\sin a \cos b} \quad (36J)$$

Equation 36J is derived in a similar manner from the oblique triangle  $ULE$

The offset  $pe$  is required if the optical axis is used as the primary line of reference Obviously,

$$pe = Te - Tp \quad (364F)$$

Inasmuch as  $TL = f \csc t$ , by the application of the law of sines to the oblique triangle  $eLT$ ,

$$\frac{Te}{\sin b} = \frac{TL}{\sin a} \quad (364G)$$

$$Te = \frac{f \csc t \sin b}{\sin a} = \frac{f \sin b}{\sin t \sin a} \quad (364H)$$

Substituting equation 364A and H in F,

$$pe = \frac{f \sin b}{\sin t \sin a} - f \cot t = \frac{f}{\sin t} \left( \frac{\sin b}{\sin a} - \cos t \right) \quad (36K)$$

This completes the derivation of the settings relative to the optical axis  $eLE$  It remains to be shown what they are with respect to the line of centers  $pLP$

Expressions for the angles  $N$  and  $S$  can be derived directly from the oblique triangle  $pLT$ , figure 3 46B From one of the standard (but seldom used) trigonometric solutions of an oblique triangle where two sides and the included angle are known,

$$\tan N = \frac{TL \sin pTL}{pT - TL \cos pTL} \quad (364I)$$

$$\tan N = \frac{(f \csc t) \sin [180^\circ - (a + b)]}{f \cot t - (f \csc t) \cos [180^\circ - (a + b)]} \quad (364J)$$

$$\tan N = \frac{\sin (a + b)}{\cos t + \cos (a + b)} \quad (364K)$$

In a similar manner in the same triangle,

$$\tan S = \frac{\sin (a+b)}{\sec t + \cos (a+b)} \quad (364L)$$

These equations, however, are not used in practice. A method employed by Mr Hotine (see footnote in 36) is used which introduces an auxiliary angle  $x$  such that

$$N = \frac{a+b}{2} + x \quad (36D)$$

$$S = \frac{a+b}{2} - x \quad (36E)$$

From equation 36D,

$$x = N - \frac{a+b}{2}. \quad (364M)$$

The tangent function of each side of equation 364M is expressed and that for the right is expanded as the tangent of the difference of two angles

$$\tan x = \frac{\tan N - \tan \left( \frac{a+b}{2} \right)}{1 + \tan N \tan \left( \frac{a+b}{2} \right)}. \quad (364N)$$

By trigonometry,

$$\tan \left( \frac{a+b}{2} \right) = \frac{\sin (a+b)}{1 + \cos (a+b)} \quad (364P)$$

Expressions 364K and P are substituted in N and the resulting expression is simplified to

$$\tan x = \frac{[\sin (a+b)] (1 - \cos t)}{[1 + \cos (a+b)] (1 + \cos t)} \quad (364Q)$$

Since from trigonometry,

$$\frac{1 - \cos t}{1 + \cos t} = \tan^2 \frac{t}{2}, \quad (364R)$$

$$\tan x = \tan \left( \frac{a+b}{2} \right) \tan^2 \frac{t}{2}. \quad (36C)$$

The cant  $c$  of the lens is

$$c = N - a \quad (36F)$$

because in the triangle  $eLp$ ,  $N$  is the exterior angle which is equal to the sum of the two opposite interior angles  $a$  and  $c$

It is now possible to express the optical distances  $pL$  and  $PL$  on the line of centers. The angles  $N$  and  $S$  are now obtainable, and  $pL$  and  $PL$  in the oblique triangles  $pLT$  and  $PLU$  can be expressed in exactly the same manner as for equations 36I and 36J

$$pL = \frac{g \sin (a+b)}{\sin N \cos b} \quad (36G)$$

$$PL = \frac{g \sin (a+b)}{\sin S \cos a}. \quad (36H)$$

The derivations of the equations are now complete for the settings of a rectifier in either of

two systems. The expressions are both necessary and sufficient to ensure proper geometric rectification as well as the condition of over-all sharp definition.

It is significant that the auxiliary angle  $x$  is directly associated with the isocenter of the photograph although the angle may not have been selected with this fact in mind. The value  $x$  is the angle formed at the lens point between the lines to the principal point and to the isocenter of the negative where the conditions of sharp focus and correct geometry are fulfilled. This fact can be proved by solving the oblique triangle  $pL_i$  for the side  $p_i$  using only the relations already determined for the angles and the side  $pL$ , thus showing that  $p_i = f \tan \frac{t}{2}$ , an expression identical to equation 3322B. The proof is not shown.

*Example 1* A photograph of focal length 200 mm is tilted  $3^\circ$  and needs to be reduced to 0.9 size. If the photograph is rectified with a lens of 600 mm focal length, what are the settings of the instrument relative to the optical axis? (These values are typical of the Coast and Geodetic Survey rectifier)

Solution

$$\cos b = 600 \sin 3^\circ - 200 = 0.15702$$

$$b = 80^\circ 58'0$$

$$\cos a = (600 \sin 3^\circ) - (200 \times 0.9) = 0.17447$$

$$a = 79^\circ 57'1$$

$$eL = (600 \sin 160^\circ 55'1) - (\sin 79^\circ 57'1 \cos 80^\circ 58'0) \\ = (600 \times 0.32692) - (0.98467 \times 0.15702) = 1268.7 \text{ mm}$$

$$EL = (600 \sin 160^\circ 55'1) - (\sin 80^\circ 58'0 \cos 79^\circ 57'1) \\ = 1138.4 \text{ mm}$$

$$pe = (200 - \sin 3^\circ) [(\sin 80^\circ 58'0 - \sin 79^\circ 57'1) - \cos 3^\circ] \\ = (200 - 0.05234) [(0.98760 - 0.98467) - 0.99863] = 16.62 \text{ mm}$$

*Example 2* Solve *example 1* for the settings referred to the line of centers. Solution The computations for the angles  $a$  and  $b$  are identical to those in *example 1*

$$\tan i = \tan 80^\circ 27'6 \tan^2 1^\circ 30' \\ = 5.9503 \times 0.02619 \times 0.02619 = 0.00408$$

$$i = 0^\circ 14'0$$

$$N = 80^\circ 27'6 + 0^\circ 14'0 = 80^\circ 41'6$$

$$S = 80^\circ 27'6 - 0^\circ 14'0 = 80^\circ 13'6$$

$$c = 80^\circ 41'6 - 79^\circ 57'1 = 0^\circ 44'5$$

$$pL = \frac{600 \sin 160^\circ 55'1}{\sin 80^\circ 41'6 \cos 80^\circ 58'0} = 1265.9 \text{ mm}$$

$$PL = \frac{600 \sin 160^\circ 55'1}{\sin 80^\circ 13'6 \cos 79^\circ 57'1} = 1140.8 \text{ mm}$$

### 365 SIMPLIFICATION OF THE FORMULAS

The perfectly general equations derived in 364 can be simplified by applying them to certain special cases, which might also result in a simplification of the design of a rectifier.

If no scale change is required ( $m = 1$ ) the formulas become in their original order of presentation

$$\cos a = \cos b = \frac{g \sin t}{f}$$

$$\tan x = \tan a \tan^2 \frac{t}{2}$$

$$N = a + x$$

$$S = a - x$$

$$c = x$$

$$Lp = \frac{2g \sin a}{\sin(a + x)}$$

(Equations 365A)

$$LP = \frac{2g \sin a}{\sin (a - x)}$$

$$Le = LE = 2g$$

$$pe = f \tan \frac{t}{2} (= p_i)$$

Thus, with reference to the optical axis, the angles of inclination of the negative and the easel are equal, the two optical distances are each equal to twice the lens focal length ( $2g$ ), and the offset distance is such that the isocenter is placed on the optical axis

If, in addition to there being no change in scale, the focal length of the rectifier lens is equal to that of the aerial camera lens ( $g = f$ ), then the relations are simplified further

$$a = b = 90^\circ - t$$

$$\tan x = \cot t \tan^2 \frac{t}{2}$$

$$N = a + x = 90^\circ - t + x$$

$$S = a - x = 90^\circ - t - x \quad (\text{Equations } 365B)$$

$$c = x$$

$$LP = \frac{2f \cos t}{\cos (t - x)}$$

$$Lp = \frac{2f \cos t}{\cos (t + x)}$$

$$Le = LE = 2f$$

$$pe = f \tan \frac{t}{2}$$

The Coast and Geodetic Survey transforming printer (figure 347), by use of which composite prints are made from for the nine-lens film, is an example of these simplifications in which, roughly,

$$g = f = 210 \text{ mm}$$

$$t = 38^\circ$$

$$m = 1$$

$$a = b = 90^\circ - 38^\circ = 52^\circ$$

$$Le = LE = 2 \times 210 = 420 \text{ mm}$$

$$pe = 210 \times \tan 19^\circ = 72 \text{ mm}$$

Rectification can be performed in a series of steps or stages instead of the single stage discussed so far. For example, if the enlargement or reduction is performed with a ratio printer independent of tilt, and then the ratioed print rectified with  $m = 1$ , the instrument and equations are simplified. Also, in equation 36A where  $\cos b = \frac{g \sin t}{f}$ , it is entirely possible for  $\cos b$  to have a value greater than one, which is impossible mathematically and photographically. (A similar situation might exist for  $\cos a$  in equation 36B.) Such might happen if  $g$  is much larger than  $f$  and if  $t$  is large (as in an oblique photograph) so that  $\sin t$  is a large fraction. Furthermore, rectification becomes somewhat difficult from the standpoint of illumination and photography if  $\cos b$  or  $\cos a$  is greater than about 0.7. One method for avoiding these difficulties is to rectify two or more times successively, each time for only a part of the tilt angle  $t$ .

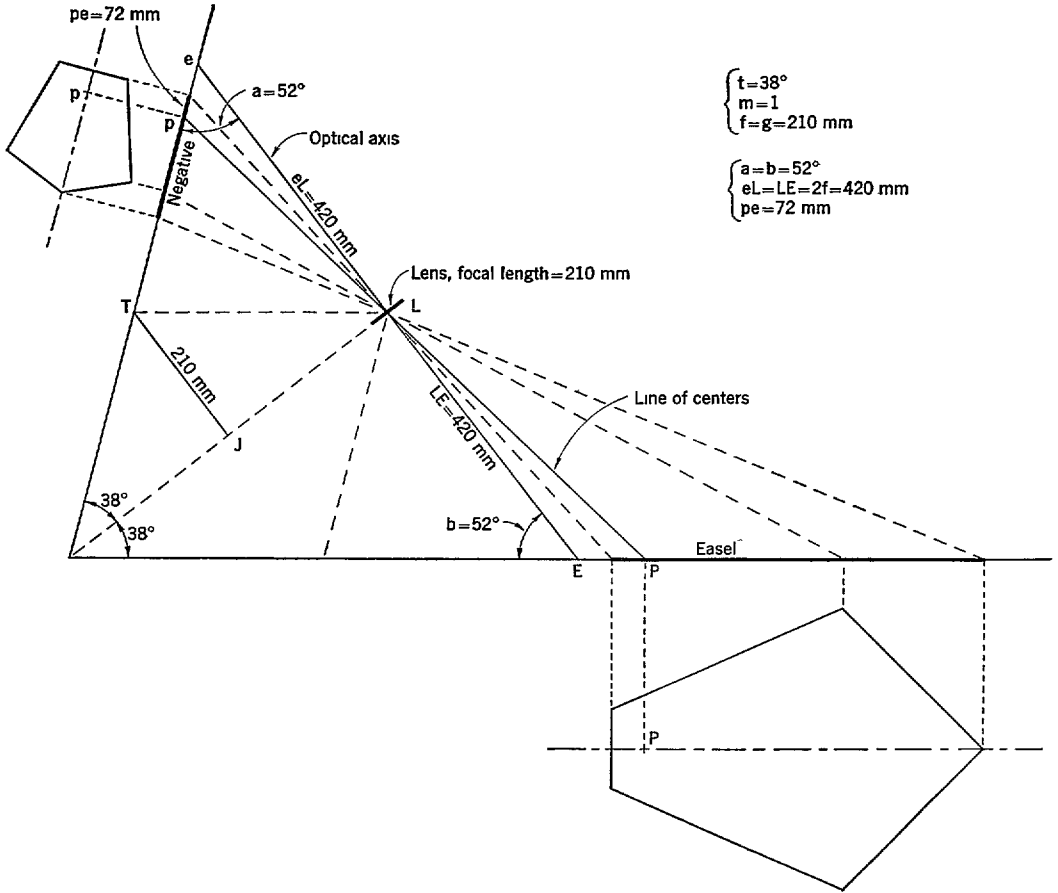

FIGURE 3 47—Constants of the transforming printer

Three general principles apply to rectification by stages where the ratios and the tilts can be combined in any desired manner

1 The resultant ratio  $m$  of the final stage is equal to the product of the ratios  $m_1, m_2, \dots$ , etc., performed by each of the stages

$$m = m_1 m_2 m_3 \dots m_n \tag{365C}$$

2 The resultant tilt  $t$  performed by all the stages is equal to the sum of the tilts  $t_1, t_2, \dots, t_n$  of each of the stages

$$t = t_1 + t_2 + t_3 + \dots + t_n \tag{365D}$$

3 In each stage, the negative needs to be in a slightly different position because after the first stage, the original principal point is not a valid reference point from which to measure either the computed offset distance  $p_1e$  nor the subsequent *cant* angles  $c$ . Therefore, for the second stage  $p_1$  is located a distance  $pp_1$  toward  $n$  from  $p$ , and  $p_1$  is used as though it were the principal point, for the third stage  $p_2$  is located a distance  $p_1p_2$  toward  $n$ , etc, where

$$pp_1 = m_1 f \tan \frac{t_1}{2}$$

$$p_1p_2 = m_1 m_2 f \tan \frac{t_2}{2}$$

$$p_2p_3 = m_1 m_2 m_3 f \tan \frac{t_3}{2}, \text{ etc} \tag{Equations 365E}$$

The settings for each stage are then computed with the standard equations using the proper  $t_n$  for that stage, and using  $f$  as usual in the first stage,  $m_1f$  in place of  $f$  for the second stage,  $m_1m_2f$  in place of  $f$  for computing the third stage, etc

Obviously, it might be easier to perform the ratio printing operation by itself as an initial or final stage. If the ratio operation is performed as an initial stage, then  $m_1f$  must be used in place of  $f$  in the computation of the settings of each of the subsequent stages with  $m_2 = m_3 = \dots = m_n = 1$ . The ratio operation is done initially or finally according as  $m_1f$  or  $f$  yields the smaller value for  $\cos b$  in equation 36*A*.

An odd number of stages results in an ordinary positive photographic print, whereas an even number of stages results in a negative print unless a reversal photographic process is employed. It is possible to use negative-toned prints with contour plotting instruments but not desirable because of the peculiar effect of the reversed shadow tones. An increase in the number of stages usually results in some loss of photographic definition, an increase in the "grain" effect, and an increase in the contrast of light and dark tones.

A proof is not given for the principles cited. The relations are evident on considering that each stage produces a photograph equivalent to some photograph taken from  $O$  (fig 346*A*) with a camera of a different but definite total length  $m_1f$ ,  $m_1m_2f$ , etc.

The use of the formulas of 36 is limited in practice to the design of rectifiers, to a basic reference guide in rectifying procedures, and to determining the settings for unusual cases. Where repeated rectifications are performed over a small range of values of tilt  $t$  and scale changes  $m$ , for the same camera focal length  $f$ , and for the same rectifier lens focal length  $g$ , then the variation in the required settings also covers a small range of values. These values frequently are approximately linear variations relative to  $t$  and/or  $m$ . For example, the Coast and Geodetic Survey rectifying camera is used repeatedly for tilts between  $0^\circ$  and  $2^\circ$  and ratios between 0.98 and 1.02, and the values  $f$  and  $g$  are fixed constants. Within this range of values the equations show that

$$S = 90^\circ - 2.96 t$$

where the greatest error is equivalent to about 20 seconds in the value of  $t$ , which is insignificant. The fact was discovered by computing many settings, plotting the settings on graph paper, and noting that the curve was almost a straight line through the origin, and that the tangent of the angle between the line and the  $x$ -axis was 2.96.

### 366 THE USE OF COMPONENT ANGLES

The angular settings for a rectifying camera were derived with reference to the principal plane of the photograph. Inasmuch as the principal plane can occur at any orientation whatsoever with respect to the fiducial marks or the edges of the photograph, it was tacitly assumed in 36 that the photograph would be rotated so that its principal plane would coincide with the principal plane of the rectifier. However, it is not always practicable to construct a rectifier to permit such a rotation. An alternative arrangement is to support each of the planes of the rectifier in a set of gimbals (figure 348) so that each plane can be inclined in any direction. Each plane is then associated with a primary and a secondary axis which intersect at a right angle, and the inclination of each plane is then the resultant of the two component inclinations of the axes. Graduated arcs can be located at the two bearing points of the axes for setting, reading, and recording the angles of inclination. The rectifier of the Coast and Geodetic Survey is constructed on this principle, with the line of centers vertical. This mechanism has many other applications, one of which is utilized in the multiplex projector.

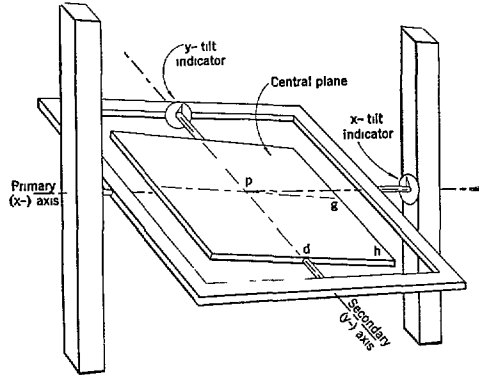

FIGURE 3 48 —Gimbal mechanism of the rectifier of the Coast and Geodetic Survey

It is frequently preferable in practice to use the complementary angles  $N' = 90^\circ - N$  and  $S' = 90^\circ - S$  rather than the angles  $N$  and  $S$ , because the former are usually small angles which are easier to manipulate. Then, in figure 3 46B,  $N'$ ,  $S'$ , and  $c$  are the inclinations of the negative, easel, and lens, respectively, relative to the horizontal.

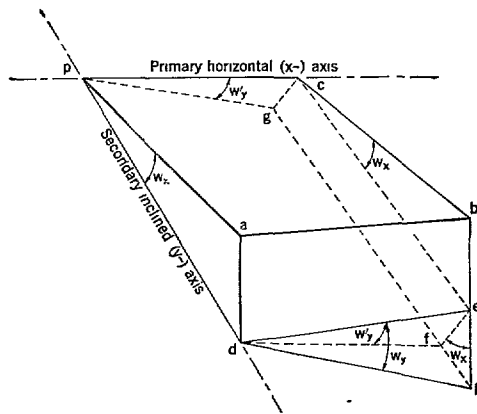

FIGURE 3 49 —Relations of component tilt angles

Let the primary and secondary axes figure 3 49 be called the  $x$ - and  $y$ -axis respectively. Let  $w_x$  be the angle of inclination of the  $y$ -axis relative to the horizontal, which is (1) the angular rotation of the central plane of the gimbal mechanism about the  $x$ -axis, (2) the  $x$ -tilt of the plane by definition, and (3) the angle measured by the  $x$ -tilt indicator. (The letter  $w$  is used here to represent any one of the angles  $N'$ ,  $S'$ ,  $c$ , or  $t$ .) Also, let  $w_y$  be the angle of inclination of the  $x$ -axis of the central plane of the gimbal mechanism relative to the horizontal. This angle is defined as the  $y$ -tilt of the plane and is not measured directly by an indicator. Let  $w'_y$  be the angular rotation of the central plane about the secondary and inclined  $y$ -axis which angle is measured directly by the  $y$ -tilt indicator, so-called. It is obvious that a photograph might occupy the central plane with the fiducial axes coinciding with the axes of rotation. Then from equations 3 463F and G,

$$\sin w_x = \sin w \cos s \tag{366A}$$

$$\sin w_y = \sin w \sin s \tag{366B}$$



where  $s$  is the swing angle. But the use of the gumbal mechanism prevents the direct recording of the true  $y$ -tilt  $w_y$  relative to the horizontal plane because the graduated arc of the  $y$ -axis measures the angle of rotation about the  $y$ -axis which is inclined at an angle  $w_x$  rather than being horizontal.

The relation between the theoretical angle  $w_y$  and the indicator angle  $w_y'$  is now considered. Figure 3 49 is a section of figure 3 48 where the letters  $p$ ,  $d$ ,  $h$ , and  $g$  refer to corresponding parts and  $p$  is the principal point of the central plane, which point always remains on both the axes. Plane  $pabc$  is the central plane in its initial horizontal position. Plane  $pdec$  represents the original plane after an inclination  $w_x$  about the primary  $x$ -axis  $pc$  is applied. Plane  $pdfg$  represents the original plane after an additional inclination  $w_y'$  about the secondary inclined axis  $pd$  is applied. Plane  $cbehfg$  is a vertical plane constructed perpendicular to the primary axis at  $c$ . Plane  $pad$  is a vertical plane constructed perpendicular to the primary axis at  $p$ . Plane  $abehd$  is a vertical plane constructed perpendicular to both  $cbehfg$  and  $pad$ . Plane  $def$  is an inclined plane that is perpendicular to the secondary axis at  $d$ . It should be noted that the deflection (angle  $feh$ ) of plane  $def$  from the vertical is equal to the inclination  $w_x$  of the secondary axis. The angle  $edh$  or  $w_y$  is the vertical angle between the line  $de$  and the final position of the plane. Since  $de$  is parallel to  $pc$  by construction,  $w_y$  is the actual inclination of the  $x$ -axis from the horizontal, or the  $y$ -tilt. And angles  $edf$  and  $cpg$  are each equal to the indicated angle of rotation  $w_y'$ .

By applying equation 3424C,

$$\tan w_y' = \tan w_y \cos w_x \quad (366C)$$

where  $w_y'$  in plane  $edf$  corresponds to  $\theta$  of the inclined plane,  $w_y$  in plane  $edh$  corresponds to  $\theta'$  of the reference plane, and  $w_x$  corresponds to  $t$ , the angle between the two planes. The relation can also be obtained directly from figure 3 49.

*Example* Compute the component settings for the complementary angles if (from example 2 in 364)

$$\begin{aligned} N &= 80^\circ 41'6 \\ S &= 80^\circ 13'6 \\ c &= 0^\circ 44'5 \\ s \text{ (swing)} &= 232^\circ 15' \end{aligned}$$

Solution

$$\begin{aligned} N' &= 90^\circ - 80^\circ 41'6 = 9^\circ 18'4 \\ S' &= 90^\circ - 80^\circ 13'6 = 9^\circ 46'4 \end{aligned}$$

Applying equations 366A, B, and C, respectively

$$\begin{aligned} \sin N'_x &= \sin 9^\circ 18'4 \cos 232^\circ 15' = (0.16167) (-0.61222) = -0.09898 \\ N'_x &= -5^\circ 40'8 \end{aligned}$$

The algebraic sign of the angle indicates the direction of rotation. The actual meaning of the sign depends on the relative location of the indicator on the rectifier, and on the direction of rotation that is considered positive.

$$\begin{aligned} \sin N_y' &= \sin 9^\circ 18'4 \sin 232^\circ 15' = (0.16167) (-0.79069) = -0.12783 \\ N_y' &= -7^\circ 20'7 \\ \tan N_y'' &= \tan -7^\circ 20'7 \cos -5^\circ 40'8 = (-0.12890) (+0.99509) = -0.12827 \\ N_y'' &= -7^\circ 18'6 \\ \sin S'_x &= \sin 9^\circ 46'4 \cos 232^\circ 15' = (0.16976) (-0.6122) = -0.10393 \\ S'_x &= -5^\circ 58'1 \\ \sin S_y' &= \sin 9^\circ 46'4 \sin 232^\circ 15' = (0.16976) (-0.79069) = -0.13423 \\ S_y' &= -7^\circ 42'9 \\ \tan S_y'' &= \tan -7^\circ 42'9 \cos -5^\circ 58'1 = (-0.13546) (+0.99458) = -0.13473 \\ S_y'' &= -7^\circ 40'4 \end{aligned}$$

$$\begin{aligned} \sin c_x &= \sin 0^\circ 44'5 \cos 232^\circ 15' = (0.01295) (-0.61222) = -0.00793 \\ c_x &= -0^\circ 27'3 \\ \sin c_y &= \sin 0^\circ 44'5 \sin 232^\circ 15' = (0.01295) (-0.79069) = -0.01024 \\ c_y &= -0^\circ 35'2 \\ \tan c_{y'} &= \tan -0^\circ 35'2 \cos -0^\circ 27'3 = (-0.01024) (+0.99997) = -0.01024 \\ c_{y'} &= -0^\circ 35'2 \end{aligned}$$

An approximate solution can be obtained for this type of problem which may yield results of sufficient accuracy, as suggested in 3424. The approximate solution is not recommended in this problem because some of the angles are greater than  $5^\circ$ . Nevertheless, the computation is performed to demonstrate the principle and the magnitude of the errors

$$\begin{aligned} N' &= 9^\circ 18'4 = 558'4 \\ S' &= 9^\circ 46'4 = 586'4 \\ N_s' &= N' \cos s = 558'4 \cos 232^\circ 15' = 558'4 (-0.61222) \\ N_{s'} &= 341'9 = 5^\circ 41'9 \\ N_{y'} &= N' \sin s = 558'4 (-0.79069) = -441'5 = -7^\circ 21'5 \\ N_{y''} &= N_{y'} \cos N_s' = -441'5 (0.99506) = -439'3 = -7^\circ 19'3 \end{aligned}$$

The correction to the  $y$ -component is frequently ignored in the approximate solution

$$\begin{aligned} S_s' &= 586'4 (-0.61222) = -359'0 = 5^\circ 59'0 \\ S_{y'} &= 586'4 (-0.79069) = -463'7 = -7^\circ 43'7 \\ S_{y''} &= -463'7 \cos -5^\circ 59'0 = -463'7 (0.99455) = -461'1 = -7^\circ 41'1 \\ c_x &= 44'5 (-0.61222) = -0^\circ 27'2 \\ c_y &= 44'5 (-0.79069) = -0^\circ 35'2 \end{aligned}$$

### 367 APPLICATION TO THE RECTIFIER OF THE COAST AND GEODETIC SURVEY

The application of the theory to the rectifier of the Coast and Geodetic Survey has resulted in a number of logical time-saving short cuts which have evolved quite naturally from the repeated use of the instrument. However, the system has grown from the initial application of fundamental principles. The result is a series of simple manipulations that, although not theoretically exact, perform well enough between certain limits of application so that the final map accuracy does not suffer. A close maintenance of the theoretical condition is considered necessary to retain the geometric and optical qualities of the photograph (values of relief displacements and parallaxes, definition of images) so that adequate results can be derived from the subsequent use of a mechanical map plotting instrument. Although this discussion refers to a specific problem, it serves as an example in the application of rather complicated theoretical principles to simplified practical procedures, as well as a discussion on rectification.

A method was devised that did not require the determination of the tilt, swing, and flying height or scale of each photograph, because such a procedure is extremely laborious. Yet these very quantities are usually required for making the settings of a rectifier. Instead, the method involves the use of a rectification templet on the easel of the rectifier. The  $x$ - and  $y$ -tilts of each of the planes, and the optical distances, are varied until the projections of the images of a photograph in the negative plane fit their respective templet positions on the easel. The final correlated settings and the "fit" of the images to the templet are obtained by a system of optical-graphic successive approximations, requiring only a small amount of time, knowledge, and mental arithmetic. The settings of the instrument are adjusted so as to satisfy the many conditions for precise rectification through the use of empirical relationships based on the theoretical equations. A record of the final adjusted settings furnishes the necessary data for computing the tilt, swing, flying height or scale, and the position of the nadir point.

A rectification templet is a templet that shows the positions of several images as they would appear on a photograph having a desired scale and tilt. Such a templet can be constructed if the positions and elevations of several objects are known and if the relative map position of the principal point is known. All the required positions at a desired scale can be obtained by radial plotting. A radial plot using transparent hand templates is always made prior to rectification in the procedure for making a topographic map from nine-lens photographs in the Coast and Geodetic Survey. Also the transparent hand radial templet furnishes the required positions in the form of needle holes left after the completion of the plot, and these positions are at the same scale as the plot. The elevations of the objects can be determined from ground surveys, existing maps, or objects at sea level can be selected. Vertical control must be available in one form or another in order for it to be possible to perform rectification or to compile a contour line from photographs. Precise rectification is rarely performed for any purpose other than for the drawing of contours. The radial templet can easily be converted into a rectification templet because the only difference is that, for the latter, the images are displaced from their map positions due to the elevations of the objects. The needle-hole positions thus require displacements radially outward from the principal point in accordance with equation 3232B,

$$d_e = \frac{r'h}{H - h'}$$

in which  $H$  is the theoretical flying height necessary to produce the scale of the templet and plot. (See fig 3 50) The procedure for determining and measuring the displacements is described more fully in 3671. It is of importance here that sufficient data are available to permit the making of a rectification templet easily and correctly

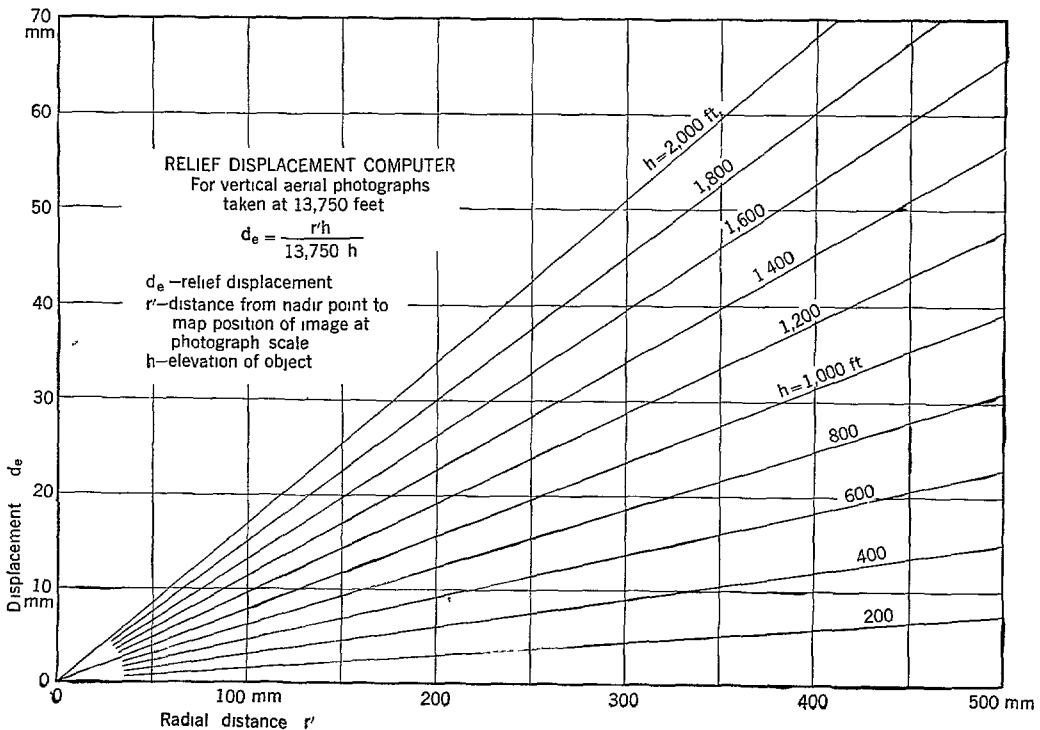

FIGURE 3 50 —Relief displacement computer

The use of nonrectified photographs in making a radial plot for rectification purposes is a practice that is entirely justified although it might seem at first that the step is inconsistent or inaccurate. Firstly, the positions of the needle holes are surprisingly accurate because the tilts of the nine-lens photographs are usually so small (the average tilt is about 40 minutes and a tilt of  $2^\circ$  is rarely encountered) that the effects on the directions of radial lines are well within the accuracy of the graphic construction of the templets. If a badly tilted photograph is encountered, the fact is readily apparent and the templet is (*a*) disregarded, (*b*) a new templet is made using the midpoint (3434) as the radial center, or (*c*) the photograph is approximately rectified. Secondly, inasmuch as the directions of the tilts from photograph to photograph are usually unrelated, the result is a tendency for the errors in one templet to nullify those of another. Thirdly, most intersections in radial plotting are composed of about six radial lines which tends further to nullify the effect of an error in any one of the radial lines. Fourthly, a superabundance of points (usually 20 or more) are used in rectification instead of the minimum of three points, and the average best fit is obtained, consistent with the observance of the correct geometric relations in the rectifier. Fifthly, the operators of the plotting instruments can immediately detect improper rectification because it is then not possible to "horizontalize" the stereoscopic model to fit vertical control points. If a photograph is found to be improperly rectified, the magnitude and direction of the apparent discrepancies are noted and the photograph is rectified again with added corrections. Consequently, these five reasons are ample assurance that the photographs are correctly rectified regardless of the fact that slightly tilted photographs are used in the radial plot.

An operator of a rectifier soon learns which motions to adjust to make a photograph fit a templet. It is done initially by operating only the two angular motions of the easel and the one linear motion of the lens with all the other motions set for the condition of no tilt and a 1:1 ratio. After a good "fit" is obtained, a record of the settings is made and these settings are distributed and adjusted so that the angular readings of the negative plane are each 6% less than those of the easel, and so that the linear setting of the easel from its 1:1 position is 2% of the change in the lens position. The directions of the angular rotations are such that the planes of the negative and the easel intersect properly. The angular settings of the lens were found to be of little or no significance. These relations were determined by plotting graphically the precise computed settings over a given range of values. (See figs 3 51, 3 52, 3 53 and 3 54.) These proportions were found to result in an error of less than 1 minute of air camera tilt if no adjusted angular setting of the rectifier were greater than about  $6^\circ$  and if the linear setting of the lens were not greater than about 10 mm. After the initial adjustment of the settings, it is usually necessary to alter them somewhat to recover the "fit", after which the settings must be readjusted, this procedure being repeated until no further adjustment improves the fit of the points.

If the settings lie beyond those limits for which the given proportions are valid, then either the graphs of the settings must be consulted to determine the proper relations, or new computations must be made. The graphs, however, cover the entire range of the instrument for photographs of 210 mm focal length, and the original graphs are constructed large enough to read the smallest division that can be set on the rectifier. The graphs shown here are obviously reduced in size for publication. It is of importance here that it is possible to set the rectifier to fit a templet without knowing the tilt, and nevertheless to adjust the settings so as to perform theoretically precise rectification.

The final adjusted settings of the rectifier are a unique indication of the tilt, swing, and flying height or scale of the photograph. In fact, the two tilt components of just one of the planes and the one optical distance for the lens are the only three quantities required for determining the photographic elements. For example, the angles  $N_x'$  and  $N_y''$  indicate simultaneously the swing of the photograph and the resultant inclination  $N$  of the negative plane through equations 366A and 366B. The position of the lens indicates the magnification performed. Then there is only one value of the photograph resultant tilt  $t$  that can give rise to such values according to equations 36A, B, D, and 364K. These values are most easily solved by means of graphs. Figure 3 55 shows a graph made from theoretically exact computed data based on the constant values of  $f$  and  $g$ , which graph indicates the location of the nadir point directly for purposes of plotting it on the photograph for use on the Reading Plotter, as well as the resultant tilt and swing of the original photograph. The value of  $pn$  can be corrected by multiplying it by  $m$  before being plotted. The value of  $m$  can be obtained from figure 3 52 from the setting of the lens.

Thus, the complete procedure of rectification can be performed simply, quickly, and accurately.

### 3671 *The Graphs of the Rectifier Settings*

The graphs of the rectifier settings are vividly informative. They are a result of computing equations 36A to H using 209.5 mm for  $f$ , 600.7 mm for  $g$ , over a range of values for  $m$  from 0.9 to 1.1 by increments of 0.1, and over a range of values for  $t$  from  $0^\circ$  to  $8^\circ$  by increments of  $1^\circ$ .

The relief displacement computer (fig. 3 50) is constructed on metric graph paper with the horizontal  $r'$  dimension at full scale. The graph shown here is for a flying height of 13,750 feet only, or for a scale of 1:20,000 if it is associated with the nine-lens camera. A completed transparent radial line templet is superposed on the computer with the principal point set at the zero-zero point  $p$ , and with the needle hole position on the horizontal line  $pr'$ . The operator traces upward from the needle hole on the nearest vertical line until he reaches the elevation  $h$  of the object, whence he reads the displacement in millimeters at the edge of the graph at an exaggerated scale. It is to be noted that the  $h$  lines of the graph are straight lines because  $d_e$  varies directly as  $r'$ .

Figure 3 51 shows how the linear setting of the lens varies with respect to the magnification. The line is a curved line because (1) from equation 317C, the setting ( $u - 2g$ ) is

$$(u - 2g) = g \left( \frac{1}{m} - 1 \right),$$

whence the setting varies as the reciprocal of the magnification less one, and (2) the lens setting is measured from the principal point whereas the factor  $m$  is effective at the isocenter. The instrument was constructed to record the departure of the lens position from the 1:1 position rather than the total distance  $pL$ . A positive setting indicates an upward motion of the lens and a value of  $m$  greater than one because the instrument is constructed in a vertical position with the easel at the base. A small tilt of the aerial camera has a relatively small effect on the setting, but the effect increases rapidly with the larger tilt angles. The curvature of the graph is slight and closely approximates a straight line for a short distance such as from  $m = 0.98$  to  $m = 1.02$ .

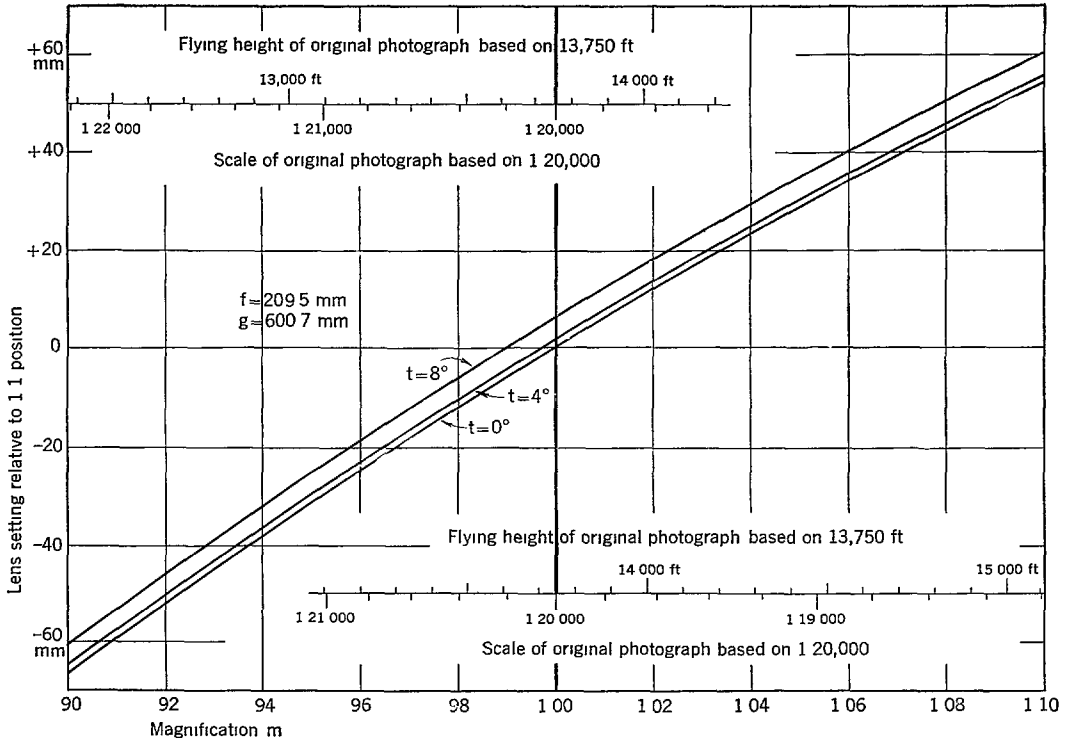

FIGURE 3 51 —Graph of the lens settings

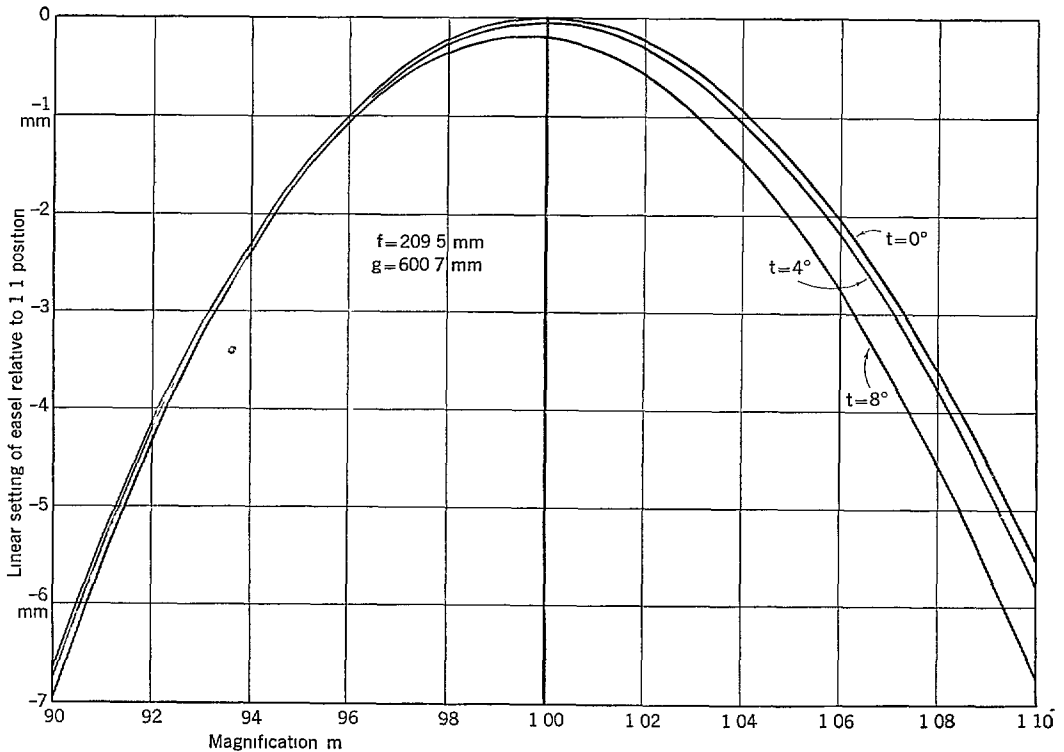

FIGURE 3 52 —Graph of the linear settings of easel

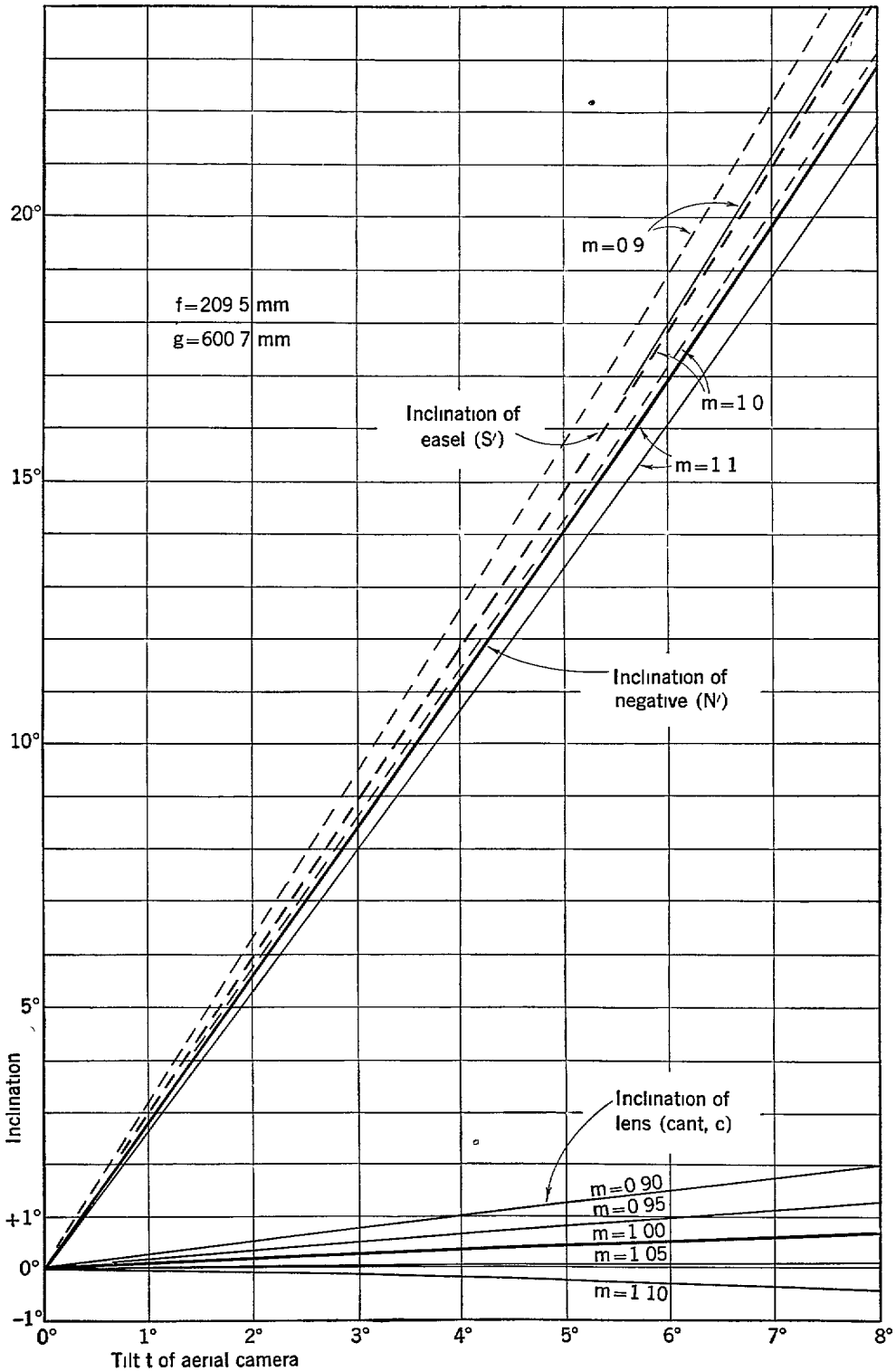

FIGURE 3 53—Graph of the angular settings

The change of the position of the easel (fig 3 52) varies a small amount with a small change in  $m$  as compared to the change in the lens position. The position of the easel is always lower (negative in algebraic sense) than the 1 1 position because the position of the negative plane is fixed and the sum of the object and image distances for any lens is minimum when  $m = 1$ . The curve is not quite symmetrical with respect to the line  $m = 1$  and the effects of tilt are small, increasing with  $m$ .

The angular settings of the easel ( $S$ ) and the negative plane ( $N$ ) (fig 3 53) are so nearly equal for small tilts that they overlap in a confusing manner. The settings vary principally with the tilt  $t$  of the aerial camera and are reduced slightly with an increase in the value of the magnification factor  $m$ . The lines are slightly curved, being essentially straight lines for tilts less than  $3^\circ$ .

The cant  $c$  of the lens (fig 3 53) is small, being only  $1^\circ 07'$  at the maximum range of the instrument for a reduction of 10 9. It is to be noted that the cant is not zero for all values of  $t$  when  $m = 1$ , and that the value is even negative under certain conditions, or opposite direction to the inclination of the other planes. For tilts of  $3^\circ$  and less the cant is but a few minutes, which is of no practical consequence.

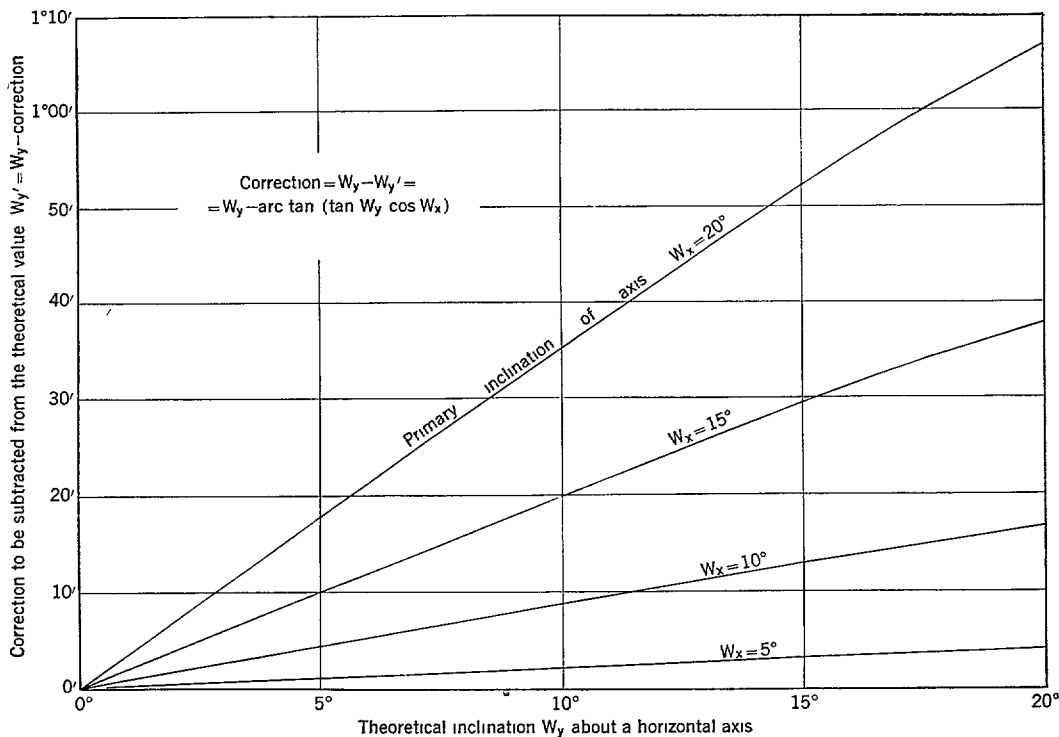

FIGURE 3 54 —Graph of corrections to the Y settings

The lines showing the correction to the secondary rotation (fig 3 54) are but slightly curved even for the entire range of the instrument, which shows that the correction is very nearly proportional to the size of the angles. For inclinations less than  $6^\circ$ , the correction is scarcely significant because 3 minutes in the value of  $N$  is roughly equivalent to 1 minute in  $t$ .



Figure 3 55 is a graph that saves a great deal of computation for the position of the nadir point, which is required for the operation of the stereoscopic plotting instrument. The figure shows but one quadrant whereas the original graph shows all four quadrants at a much larger scale and for but about half of the range of the instrument ( $10^\circ$ ). The nadir point position is thus located on the graph in the same relative position where it must be plotted on the photograph because the photograph is always placed in the rectifier in the same orientation. The curved lines are not true circles inasmuch as they incorporate all the corrections except that caused by  $m$  not being unity. This effect of  $m$  is not significant because (1) the effect of  $m$  on the  $N$  angles is not great (fig 3 53), (2) the angles  $N$  usually encountered are small, and (3) the value of  $m$  usually differs only slightly from one. If the value of  $pn$  taken from the graph is multiplied by the factor  $m$ , the product differs from the correct value of  $pn$  by less than 0.1 mm. This final correction is so small that it is usually not applied.

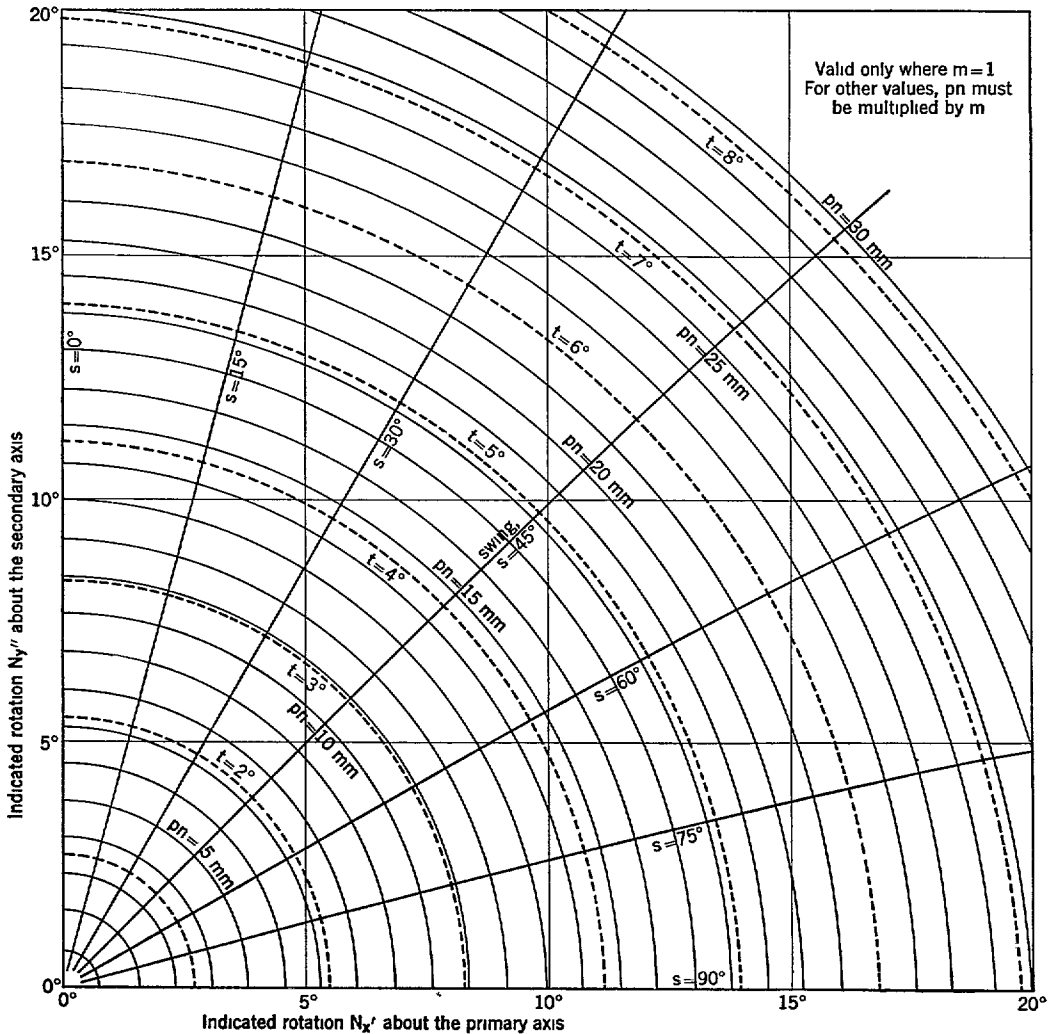

FIGURE 3 55 —Nomogram for determining the position of the nadir point after rectification

### 37. HORIZONTAL AND OBLIQUE PHOTOGRAPHS<sup>6</sup>

A horizontal photograph is one taken with a camera whose axis was horizontal at the instant of exposure. Horizontal photographs are usually taken with a special camera (phototheodolite or camera transit) supported on a tripod on the ground. Near horizontal photographs are sometimes taken from the deck of a ship but they are almost never taken from an airplane.

An oblique photograph is one taken with a camera whose axis was intentionally inclined at an angle between the horizontal and the vertical at the instant of exposure. Oblique photographs are usually taken from an airplane, but sometimes they are taken from the ground in the same manner as horizontal photographs. There is no sharp line of demarcation between an oblique photograph and a near-vertical one, but it might be said that an oblique photograph usually is tilted more than  $5^\circ$  from the vertical. A near-horizontal photograph is considered as an oblique photograph.

A high oblique photograph is one on which the image of the horizon appears, and a low oblique photograph is one on which it does not appear.

Trimetrogon photography consists of overlapping sets of three photographs exposed simultaneously, each set containing one vertical and two high obliques—one to the right and one to the left of the vertical. The resulting photographic coverage is from horizon to horizon normal to the line of flight. The trimetrogon system is an outstanding application of the geometric principles of oblique photographs. The term *metrogon* refers to the use of camera lenses bearing that trade name.

Horizontal and oblique photographs are sometimes taken by the Coast and Geodetic Survey to supplement vertical photographs, to assist in establishing supplementary control for use with vertical photographs, to assist in the identification of control stations, and to furnish a pictorial record of landfalls. Trimetrogon photographs are used infrequently in this Bureau.

The methods described herein for oblique photographs are based on the article by Mr. R. M. Wilson<sup>6</sup>.

A horizontal or oblique photograph is a graphic record of horizontal and vertical angles that might have been observed at the camera station with a transit or theodolite. These angles can be measured from the photograph with an accuracy of about 1 minute of arc or better. The angles can then be used in various ways to determine the positions and elevations of features for mapping purposes.

#### 371 THE HORIZONTAL PHOTOGRAPH

A horizontal photograph is usually obtained with a phototheodolite or a camera transit which consists essentially of a surveying camera mounted on a tripod with a means provided for leveling the camera axis. Horizontal and vertical circles are often incorporated for pointing the camera in any desired and measurable direction, and a level bubble perpendicular to the camera axis is usually also included. The horizontal and vertical angles can be obtained from the photographs by graphic methods, or by a special instrument called a photoalidade (fig. 356), phototransit, or photogoniometer. The horizontal photograph has many applications in map making and a study of the principles provides a foundation for considering the oblique photograph.

<sup>6</sup> Wilson, R. M., Oblique photographs for the surveyor. Photogrammetric Engineering, vol. VIII, no. 1, 1942.

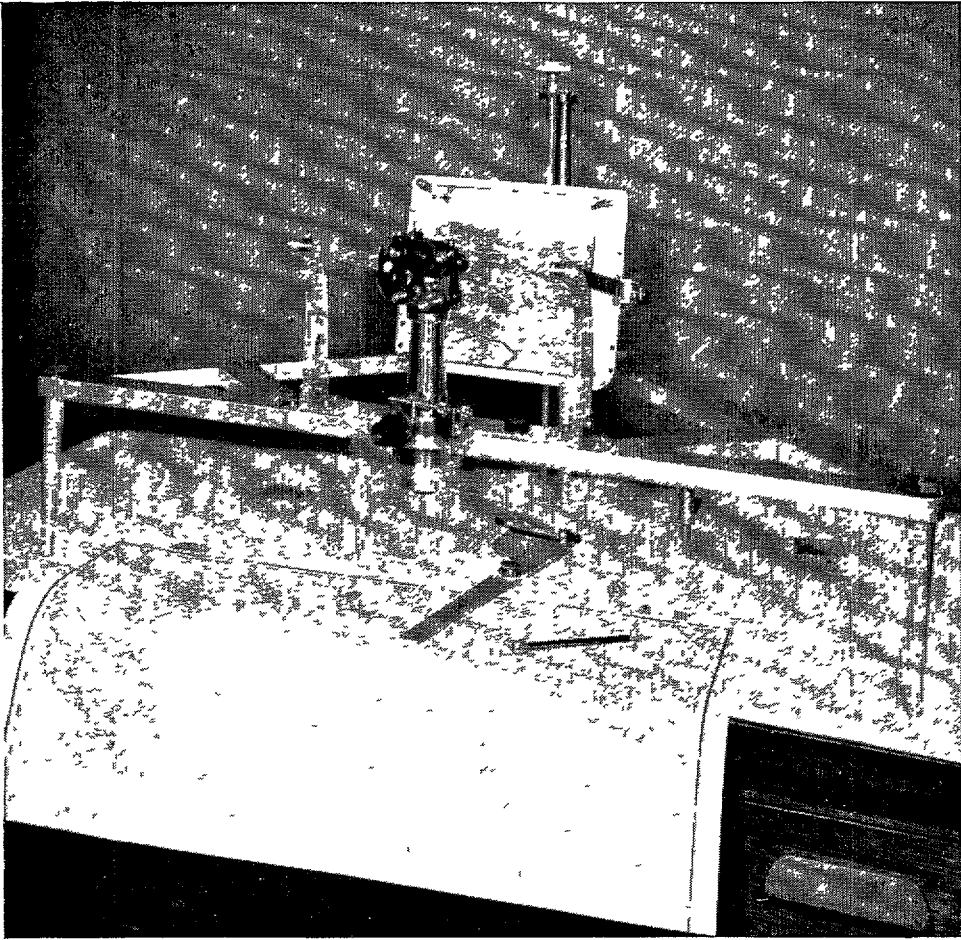

FIGURE 3 56 —The Wilson photoalidade

### 3711 Nomenclature and Geometry

Figure 3 57 shows a positive print of a horizontal photograph with the image  $a$  and the fiducial marks  $b$ ,  $c$ ,  $d$  and  $e$ . A line on the photograph connecting the fiducial marks  $bc$  represents a truly horizontal line at the same level as the camera station or the original perspective center. This line is logically called the *horizon line* because it represents the true horizon. Obviously, the horizon line passes through the same images as would be swept by the crosshairs of a leveled transit or theodolite that occupied the same station. The line  $de$  connecting the other two fiducial marks represents a truly vertical line and intersects the horizon line at the principal point of the photograph on the axis of the camera lens. It is obvious also that any line perpendicular to the horizon line is a truly vertical line and that it passes through the same images as would be swept by the crosshairs of a transit as the telescope is rotated through a vertical angle.

The perspective center of the photograph is  $O$  on the line perpendicular to the plane of the photograph at the principal point and a distance  $f$  from  $p$ , where  $f$  is the focal length of the camera. The line  $aa'$  is constructed perpendicular to the horizon line and the lines  $Op$ ,  $Oa$ , and  $Oa'$  are drawn. Then the angle  $\theta = pOa'$  is the horizontal angle between the

vertical plane  $Opd$  and the object, the same angle that would be measured with a transit. Moreover the horizontal angle between any other object and the object of  $\alpha$  might be expressed as the sum (or difference) of the angles which lines such as  $Oa'$  make with the camera axis  $Op$ .

The angle  $\alpha = aOa'$  is the vertical angle between the horizontal plane that contains the horizon line and the object, the same angle of elevation (or depression) that would be measured with a transit.

### 3712 Graphic Determination of Horizontal Angles

Horizontal angles between objects can be determined graphically with a relatively simple procedure. Figure 3 58 shows the same photograph as in figure 3 57, but as it might appear if laid on a table. Suppose the line  $pO$  is constructed perpendicular to the horizon line and of length  $f$ . Also let  $aa'$  be constructed perpendicular to the horizon line and the line  $Oa'$  be drawn. Then the angle  $pOa' = \theta$ , a true horizontal angle as described in 3711. The operation might be visualized as equivalent to rotating triangle  $pOa'$  of figure 3 57 about the line  $pa'$  downward until the line  $pO$  lies in the plane of the photograph.

Thus, any horizontal angle can be obtained graphically from a horizontal photograph by the following steps:

- 1 Fasten the photograph to a drawing board
- 2 Construct the horizon line, locating the principal point  $p$ , and construct a line perpendicular to the horizon line at  $p$
- 3 Locate the perspective center  $O$  a distance  $f$  from  $p$  and on the constructed perpendicular of (2)
- 4 Construct another perpendicular from each image to the horizon line and connect the perspective center  $O$  with the foot of each perpendicular
- 5 Then the angle between any two of these lines is the horizontal angle at the camera station subtended by the corresponding objects

The horizontal angles are usually employed graphically in the form of a templet with a system of rays or radial lines radiating from  $O$  for determining the horizontal posi-

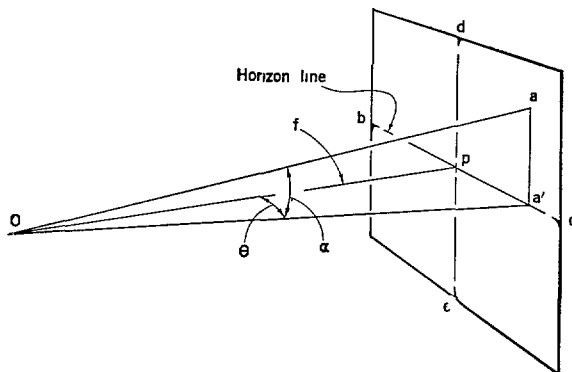

FIGURE 3 57—Geometry of the horizontal photograph

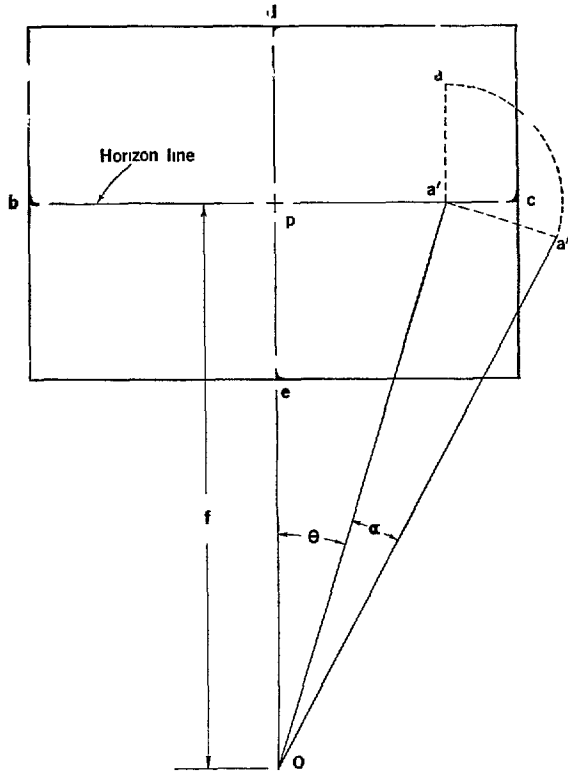

FIGURE 3 58—Graphic determination of horizontal and vertical angles to an object using a horizontal photograph

tions of objects as in a radial plot. The templet is constructed by superposing on the photograph, after the first step, a transparent drafting medium and performing all the graphic construction on the templet. The templet differs from the usual templet of the radial line method only in that the rays form only a limited angular coverage about the perspective center rather than a 360° coverage about the principal point of a vertical aerial photograph. Horizontal control points can thus be utilized and the graphic solutions of resection and intersection performed in a manner similar to 3252 and 3253.

Templets covering the full circle are also frequently made from a series of horizontal photographs taken from the same camera station in panoramic fashion so that there is some overlap between adjacent photographs. The templet is constructed by either of two methods: (a) the ray of a common image near the edge of one photograph is used as the first image ray of the adjacent photograph, or (b) the pointing of the camera axis is recorded by reading the horizontal circle of the camera transit for each exposure and the photograph perpendiculars on the templet are constructed with these same angles.

The angles can also be determined with the photoalidade (fig 3 56) and can be determined numerically or traced graphically onto a templet. Such an instrument is constructed so as to duplicate the geometry of original transit observations. The accuracy of such a device depends on the definition of the photographic image and the distortion characteristics of the lens and of the photographic materials. Accordingly, glass plates are frequently used for horizontal photographs, the glass plate negatives are frequently used directly on the instrument, and the camera lenses are usually narrow angle and slow, but

possess very high resolving power and very low distortion. The angular accuracy of a sharply defined image is usually about 1 minute or better.

### 3713 Graphic Determination of Vertical Angles

Vertical angles to objects can also be obtained from horizontal photographs by a simple graphic procedure. In figure 3 58 construct  $a'a''$  perpendicular to  $Oa'$  and equal in length to  $aa'$ . Then in the right triangle  $Oa'a''$ , angle  $a'Oa''$  is the vertical angle of elevation  $\alpha$  equal to the corresponding angle  $aOa'$  of figure 3 57. The angle can be measured with a protractor if desired, but it is more accurate to determine the angle from the relation

$$\tan \alpha = \frac{aa'}{Oa'} \quad (3713A)$$

in which  $aa'$  and  $Oa'$  are measured, the quotient computed, and the angle obtained from tables. Inasmuch as the tangent function of the angle is used to determine the elevation of the object, the angle itself need not be determined.

The measuring and computing can be eliminated by constructing the point  $a''$  on the radial templet for use after the radial plot is laid. In figure 3 59,  $O_1$  and  $O_2$  are the perspective centers of two horizontal templets laid in a simple radial plot to fit control. The point  $A$  is intersected by the radial lines of the respective templets, the radials being constructed as in 3712. The line  $Ab_1$  is constructed perpendicular to  $O_1A$  and intersects  $O_1a''$  (extended) at  $b$ . Then  $Ab_1 = \Delta h_1$  represents the difference in elevation between the object and the camera station at the same scale as the radial plot—the scale at which the horizontal control points are plotted.

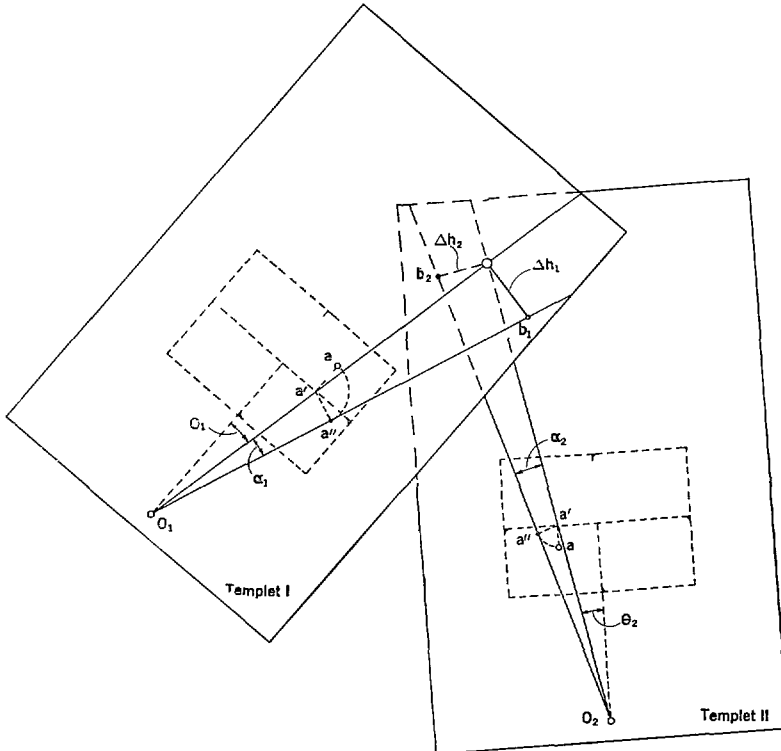

FIGURE 3 59—Graphic determination of elevation difference

The justification of this procedure is quite obvious because the difference in elevation  $\Delta h_1$  is

$$\Delta h_1 = M \tan \alpha_1 \quad (3713B)$$

where  $M$  is the horizontal ground distance from the camera station to the object. In the similar right triangles  $O_1Ab_1$  and  $O_1a'a''$ ,

$$\frac{Ab_1}{a'a''} = \frac{O_1A}{O_1a'}$$

$$Ab_1 = O_1A \frac{a'a''}{O_1a'}$$

But  $Ab_1 = \Delta h_1$  and  $O_1A = m$  at the scale of the radial plot, and the fraction is  $\tan \alpha_1$  by construction. Then equation 3713B is obtained by substitution. The result might also be checked in a similar manner from the other templet.

A computational method of determining elevations is more accurate and somewhat more practical than the graphic method. If the letter  $y$  is used to represent the photographic dimension  $aa'$  and if  $m$  represents  $Oa'$ , then by substitution in equation 3713A,

$$\tan \alpha = \frac{y}{m} \quad (3713C)$$

and equation 3713B can then be expressed as

$$\Delta h = \frac{My}{m}. \quad (3713D)$$

The difference of elevation can be computed using this equation in which  $M$  can be scaled from a published map or from a radial plot that is made either with the horizontal photographs or with a separate set of vertical photographs. The dimension  $y$  can be scaled directly from the photograph and  $m$  can be scaled from a graphic construction as  $Oa'$  in figure 3 58.

The dimension  $m$  can also be computed with some added accuracy and without the construction of figure 3 58. Let  $x$  represent the distance  $pa'$ . Inasmuch as triangle  $Opa'$  is a right triangle with  $Op = f$ ,

$$m = Oa' = \sqrt{x^2 + f^2}$$

If this expression is substituted in equation 3713D,

$$\Delta h = \frac{My}{\sqrt{x^2 + f^2}} \quad (3713E)$$

Thus  $\Delta h$  can be computed with a minimum of graphic construction with the three scaled quantities  $x$ ,  $y$ , and  $M$ . The graphic step consists only of constructing  $aa'$  perpendicular to the horizon line.

Vertical angles, also, can be measured with greater accuracy with a photoalidade, or similar instrument, than they can be determined graphically. The photoalidade, like a transit, indicates the vertical angle on a vertical circle. To determine accurate elevations, it is usually necessary to measure the vertical angle with all possible accuracy because (a)  $\tan \alpha$  is the weakest term in equation 3713B, (b) the distance  $M$  is usually a large quantity that can be measured with relatively great accuracy, and (c) the difference in elevation is usually a relatively small quantity.

A practical procedure is outlined for obtaining the desired elevation for any image on a *horizontal* photograph where at least one image can be identified whose elevation is known and where the elevation of the camera station is not known. Corrections for earth curvature and atmospheric refraction (372) are incorporated, an angle of elevation is considered as positive, and an angle of depression is considered as negative.

1 Measure the distance  $M$  from the camera station to the vertical control station and to the desired object by using a radial plot, or by any other available means.

2 Adjust the elevation of the vertical control station by subtracting from it the curvature and refraction correction as shown by table 32 or 33.

3 Compute the difference in elevation between the vertical control station and the horizon line by equation 3713B,  $D$  or  $E$ , or by the graphic method.

4 Determine the elevation of the horizon line (which is also the elevation of the camera station) by adding algebraically the difference in elevation to the adjusted elevation of the control station. Check by using another vertical control station, if available. (If the elevation of the camera is known as by leveling, steps 1 to 4 are not required.)

5 Compute the difference in elevation between the horizon line and the object, in the same manner as step 3.

6 Determine the observed elevation of the object by adding algebraically the difference in elevation of (5) to the elevation of the horizon line.

7 Correct the observed elevation by adding to it a curvature and refraction correction from table 32 or 33. Check the final elevation by using another photograph, if available.

*Example* The distance from a phototheodolite station to an object of known elevation (in this example a boulder on the shore at the water's edge) is 7,540 feet, and the distance to a mountain peak is 9,860 feet, as determined from a radial plot. The angle of depression to the boulder is measured on the photograph to be  $2^{\circ} 17'$ , and the angle of elevation to the peak is  $3^{\circ} 24'$ . What is the elevation of the peak?

Solution

Elevation  $h_1'$  of boulder corrected for curvature and refraction

$$h_1' = h_1 - c = 0 - 1.2 = -1.2 \text{ feet}$$

Difference in elevation  $\Delta h_1$ , boulder to theodolite

$$h_1 = M \tan \alpha = 7540 \tan 2^{\circ} 17' = 7540 \times 0.03987 = 300.6 \text{ feet}$$

Elevation  $h_0$  of phototheodolite

$$h_0 = h_1' + \Delta h_1 = -1.2 + 300.6 = 299.4 \text{ feet}$$

Difference in elevation  $\Delta h_2$ , phototheodolite to peak

$$\Delta h_2 = M \tan \alpha = 9860 \tan 3^{\circ} 24' = 9860 \times 0.05941 = 585.8 \text{ feet}$$

$$\text{Elevation } h_2' \text{ of peak } h_2' = h_0 + \Delta h_2 = 299.4 + 585.8 = 885.2 \text{ feet}$$

Elevation  $h_2$  of peak corrected for curvature and refraction

$h_2 = h_2' + c = 885.2 + 2.1 = 887.3$  feet above the water surface. (The elevation can be referenced to mean sea level by means of tide tables as discussed in 3714.)

### 3714 *Horizontal Photographs for Coastal Surveys*

With reference to 3713, horizontal photographs taken with a phototheodolite are sometimes used to obtain supplemental vertical control stations for stereoscopic contouring with vertical aerial photographs.

In this application of photogrammetry, the height of the instrument (the height of the camera station) is usually known and each individual photograph, or panorama of several photographs, taken from a camera station, includes an object of known elevation or a section



of tidal shoreline. A panorama is a series of two or more photographs taken with a side lap of at least 1 inch so that the photographs can be joined by common pass points in the overlap and thus used as a unit in measuring angles in the office. The two objects of known elevation, or sections of tidal shoreline, must be near the two ends of the panorama, and where the panorama includes the entire horizon, three objects spaced 90° to 120° apart are necessary. The procedure described in **3713** is applicable with the changes discussed under this heading.

The camera station and objects of known elevation included in the panorama are identified on the vertical aerial photographs in the field. The camera station, objects of known elevation, and objects for which elevations are to be determined, are located by a radial plot of the vertical aerial photographs in the office. Distances from the camera station to the objects are then scaled from the radial plot as in step 1 of **3713**.

With reference to step 2 of **3713**, any identifiable point on the shoreline and at the water surface, or referenced vertically to the water surface, will serve as a vertical control station, provided its elevation is corrected to the reference datum. The date and time for each camera station are recorded, and points at the tidal water surface can be referenced to mean-high water or mean-sea level by means of concurrent tide observations, when these are made, or by means of the predicted tide tables. The reference datum for topographic mapping is mean-sea level and in the following example elevations are computed with reference to mean-sea level. However, it is sometimes convenient to compute all the elevations with reference to mean-high water and later convert them to mean-sea level.

With reference to steps 3 and 4 of **3713**, and to the preceding paragraph, vertical control stations are theoretically unnecessary if the elevation of the camera is known because the phototheodolite is leveled for each exposure. However, such stations are usually included in each panorama as a check on the leveling of the instrument. These stations of known elevations are then used in the office computation to check the accuracy of the horizon line as indicated by the fiducial marks and to correct the position of the line if necessary.

The elevations of objects visible in the horizontal photographs are then determined by steps 5 to 7 of **3713**. All elevations are usually determined first with reference to mean-high water and later converted to mean-sea level. Elevations to be used to control the contouring are determined from at least two camera stations and preferably from three.

*Example* Consider that a photograph was taken at a recorded time and date with a phototheodolite having a focal length of 179.7 mm, the elevation of the lens being 273 feet above the tidal water surface as determined by trigonometric leveling. The camera station is considered as having been identified and marked on a vertical aerial photograph supplied for that purpose as well as for field inspection. The problem is to determine in the office the elevation relative to mean sea level of a particular object from measurements relative to the image on the horizontal photograph.

*Solution* Distances to the image are measured on the horizontal photograph: the image is 517 mm above the horizon line ( $y$  or  $aa'$  in fig. 357). And 74.2 mm to the left of the principal line ( $x$  or  $pa'$  in fig. 357). The camera station and the object are located in horizontal position by means of a radial plot of vertical aerial photographs and the distance  $M$  between them is scaled from the plot— $M = 4,190$  meters. From the Tide Table for the particular area and time, it is determined that the water surface was 27 feet below mean sea level. The apparent difference in elevation between the camera and the object is thus determined by using equation 3713E

$$\Delta h = \frac{4190 \times 517}{\sqrt{74.2^2 + 179.7^2}} = 111.4 \text{ meters} = 365.5 \text{ feet}$$

The correction for curvature and refraction from table 33 for 4,190 meters distance is 3.9 feet. Therefore, the mean sea level elevation of the object is equal to the height of the instrument minus the

tide correction plus the computed height difference  $\Delta h$  plus the correction  $c$  for curvature and refraction

$h = 273 - 27 + 365.5 + 3.9 = 645$  feet above mean sea level (If the photoalidade had been used instead of the graphic method, the angle  $\alpha$  would have been measured for the image directly, and the equation 3313B would have been used in place of 3313E, but the rest of the determination would have been identical)

### *3715 Near-Horizontal Photographs for Coastal Surveys*

With reference to **3713** and **3714**, near-horizontal photographs taken with a hand-held surveying camera from aboard ship are also used to obtain supplemental vertical control stations for stereoscopic contouring with vertical aerial photographs

In this application, each individual photograph includes the shoreline and the skyline. Several overlapping photographs are frequently taken in a set, but only a few photographs are included in each set to avoid the effect of ship drift. Since the photographs are near-horizontal instead of truly horizontal photographs, the shoreline in each photograph is used as a reference to establish the true horizon line. The height of the camera above the water surface, the date, the time, and the approximate height of swells are recorded for each panorama. The horizontal position of the camera at each set is determined by a three-point sextant fix with check angle.

The horizontal position of the camera at each set can also be determined, but with somewhat less accuracy, in the office by graphic resection, using angles to shore objects as determined from the near-horizontal photographs. In this case the shore objects must be identified on both the near-horizontal photographs and the vertical aerial photographs. The objects must then be located in horizontal position by means of a radial plot of the vertical aerial photographs.

With reference to step 1 of **3713**, the horizontal positions of the shoreline reference points that are used to establish the horizon line, the reference objects that are observed in taking the sextant fixes, and all objects whose elevations are to be determined from the near-horizontal photographs, are determined by means of the radial plot of vertical aerial photographs. The camera stations are plotted on the base sheet or manuscript by using the sextant fixes or by means of templates as discussed in the preceding paragraph, and distances from each camera station to the objects are then scaled from the base sheet or manuscript.

The office procedure differs from steps 2 to 4 inclusive of **3713**, because these are near-horizontal photographs and the true horizon must be established by reference to the shoreline. For this purpose, two shoreline images on each photograph, one near each edge, must be selected. These images must be at the water surface or referenced thereto. The true horizon line (the intersection of the horizontal plane through the camera station with the photograph) is established by measuring upward from the images of two or more shoreline images a distance that represents the elevation of the camera station, with corrections being made for curvature and refraction.

Elevations of objects visible on the photographs are then determined by steps 5 to 7 inclusive of **3713**. The elevations thus computed refer to the water surface and must be converted to mean sea level by means of concurrent tide observations or predicted tide tables.

It is sometimes preferable to establish the true horizon line with reference to mean-high water. This can be done by referencing the shoreline reference points and the camera station to mean-high water instead of to the water surface. In fact, where the shoreline

is well defined, the office photogrammetrist will often select shoreline reference points at mean-high water rather than exactly at the water surface

The method discussed here is very similar to the sextant method described in Special Publication No 143, Hydrographic Manual, Subject 382. A more detailed analysis follows.

The elevation of the camera  $H$  was shown in 3713 to be equal to the elevation  $h$  of a station minus the curvature and refraction correction  $c$  plus the computed elevation difference  $\Delta h$  between the camera and the station, or

$$H = h - c + \Delta h \quad (3715A)$$

Equation 3713E is a convenient expression for  $\Delta H$ ,

$$\Delta h = \frac{My}{\sqrt{x^2 + f^2}} \quad (3715B)$$

where  $M$  is the horizontal ground distance from the camera to the station,  $y$  is the vertical distance on the horizontal photograph from the image of the station to the horizon line,  $x$  is the horizontal distance from the image to the principal line, and  $f$  is the focal length of the camera. By substituting equation 3715B in A and solving the resulting expression for  $y$ ,

$$y = \frac{(H - h + c) \sqrt{x^2 + f^2}}{M}.$$

In the special case where the control station is an object on the shoreline (at the water surface),  $h$  is considered to be zero, and

$$y = \frac{(H + c) \sqrt{x^2 + f^2}}{M} \quad (3715C)$$

In this expression,  $H$  and  $f$  are known,  $M$  can be scaled from the map manuscript or base grid,  $c$  can be obtained from table 3 1 or 3 2 based on the value of  $M$ ,  $x$  can be scaled from the photograph, whence  $y$  can be computed. If this solution is performed for two shoreline objects, one near each of the margins of the photograph, the  $y$ -distances can be scaled upward from the images to establish two points on the true horizon line. The derivations of these expressions were based on the assumption of a truly horizontal photograph. However, the system can be used also on near-horizontal photographs with little difficulty if the camera axis is within  $5^\circ$  of being horizontal.

A similar method is used in a more direct manner with the photoalidade where corresponding depression angles from the horizon line down to shoreline images are obtained directly from an appropriate table and set in the instrument.

By substituting from equation 3713B for  $\Delta h$  in equation 3715A, and solving for  $\tan \alpha$ ,

$$\tan \alpha = \frac{H - h + c}{M}.$$

The value of  $h$  is zero for shoreline objects, whence the term is again omitted for this special case. Inasmuch as  $\alpha$  is a small angle because the ship is a large distance  $M$  offshore relative to the value of  $H$ , the tangent of  $\alpha$  is essentially proportional to the angle itself.

$$\tan \alpha = 0.000291 \alpha \text{ (in minutes)}$$

This angle is also called the *depression* of the shoreline. Then, by substitution, the depression angle  $D$  is

$$D \text{ (in minutes)} = \frac{H + c}{0.000291 M} = \frac{3436 (H + c)}{M}$$

where  $H$ ,  $c$  and  $M$  are expressed in the same units of measurement. Inasmuch as it is customary to measure  $H$  and  $c$  in feet and convenient to scale  $M$  in meters,

$$D \text{ (in minutes)} = \frac{1047 (H + c) \text{ (both in feet)}}{M \text{ (in meters)}} \quad (3715D)$$

Table 3 4 is based on this equation

Thus the true horizon of a near-horizontal photograph can be set on the horizontal plane of vision of the photoalidade by observing two marginal shoreline objects with the proper depression angle set on the vertical circle and orienting the photograph so that each image is seen on the horizontal crosshair, the dip angles being taken from the table with respect to the values of  $H$  and  $M$ . The method is independent of the size of the depression angle  $T$  of the photograph, which was not true for the graphical method. Once the true horizon is established, vertical angles to objects can be determined graphically or with the photoalidade, and elevations can be computed.

### 372 CURVATURE AND REFRACTION

Earth curvature and atmospheric refraction have a significant effect on the elevations obtained from horizontal and oblique photographs. The error is related chiefly to the distance from the camera station to the object, and is customarily obtained from tables of corrections. The effect is such as to increase the observed elevation.

$$h = h' + c$$

where  $h$  is the correct elevation,  $h'$  is the observed elevation, and  $c$  is the combined correction for curvature and refraction. Conversely, the elevation of a vertical control station must be diminished by the amount of the correction before being used for determining the elevation of the horizon line on the photograph.

Table 3 1 gives the combined corrections for intervals of 1,000 feet based on the usual relation<sup>7</sup>

$$c \text{ (in feet)} = 0.574 M^2 \text{ (in miles)} \quad (372A)$$

By conversion of units,

$$c \text{ (in feet)} = 20.59 \times M^2 \text{ (in feet)} \times 10^{-9} \quad (372B)$$

$$c \text{ (in feet)} = 0.2216 M^2 \text{ (in meters)} \times 10^{-6} \quad (372C)$$

<sup>7</sup> Special Publication No. 145, Manual of Second and Third Order Triangulation and Traverse, U. S. Coast and Geodetic Survey, 1935, page 21.

TABLE 3 1—Elevation corrections for curvature and refraction

Distance <i>M</i> in thousands of feet	Correction <i>c</i> in feet	Distance <i>M</i> in thousands of feet	Correction <i>c</i> in feet	Distance <i>M</i> in thousands of feet	Correction <i>c</i> in feet
1	0	31	19 8	61	76 6
2	1	32	21 1	62	79 1
3	2	33	22 4	63	81 7
4	3	34	23 8	64	84 3
5	5	35	25 2	65	87 0
6	7	36	26 7	66	89 7
7	10	37	28 2	67	92 4
8	13	38	29 7	68	95 2
9	17	39	31 3	69	98 0
10	21	40	32 9	70	100 9
11	2 5	41	34 6	71	103 8
12	3 0	42	36 3	72	106 7
13	3 5	43	38 1	73	109 7
14	4 0	44	39 9	74	112 8
15	4 6	45	41 7	75	115 8
16	5 3	46	43 6	76	118 9
17	6 0	47	45 5	77	122 1
18	6 7	48	47 4	78	125 3
19	7 4	49	49 4	79	128 5
20	8 2	50	51 5	80	131 8
21	9 1	51	53 6	81	135 1
22	10 0	52	55 7	82	138 4
23	10 9	53	57 8	83	141 8
24	11 9	54	60 0	84	145 3
25	12 9	55	62 3	85	148 8
26	13 9	56	64 6	86	152 3
27	15 0	57	66 9	87	155 8
28	16 1	58	69 3	88	159 4
29	17 3	59	71 7	89	163 1
30	18 5	60	74 1	90	166 8

$$c \text{ (in feet)} = 20.59 M^2 \text{ (in feet)} \times 10^{-9}$$

TABLE 3 2—Elevation corrections for curvature and refraction

Distance <i>M</i> in meters	Correction <i>c</i> in feet	Distance <i>M</i> in meters	Correction <i>c</i> in feet	Distance <i>M</i> in meters	Correction <i>c</i> in feet
500	1	10,500	24 4	20,500	93 1
1,000	2	11,000	26 8	21,000	97 7
1,500	5	11,500	29 3	21,500	102 4
2,000	9	12,000	31 9	22,000	107 3
2,500	14	12,500	34 6	22,500	112 2
3,000	2 0	13,000	37 4	23,000	117 2
3,500	2 7	13,500	40 4	23,500	122 4
4,000	3 5	14,000	43 4	24,000	127 6
4,500	4 5	14,500	46 6	24,500	133 0
5,000	5 5	15,000	49 8	25,000	138 5
5,500	6 7	15,500	53 2	25,500	144 1
6,000	8 0	16,000	56 7	26,000	149 8
6,500	9 4	16,500	60 3	26,500	155 6
7,000	10 9	17,000	64 0	27,000	161 5
7,500	12 5	17,500	67 9	27,500	167 6
8,000	14 2	18,000	71 8	28,000	173 7
8,500	16 0	18,500	75 8	28,500	180 0
9,000	18 0	19,000	80 0	29,000	186 4
9,500	20 0	19,500	84 2	29,500	192 8
10,000	22 2	20,000	88 6	30,000	199 4

$$-c \text{ (in feet)} = 0.2216 M^2 \text{ (in meters)} \times 10^{-4}$$

Where the camera station is elevated above a water surface (or flat land) whose image constitutes the apparent horizon on a horizontal photograph, then there is a distinct difference between this apparent horizon and the horizon indicated by the fiducial marks. This difference is the *DIP* angle and is caused by the elevation of the camera, earth curvature, and atmospheric refraction. The dip angle can be expressed as a function of the elevation of the camera <sup>8 9</sup>

$$Dip \text{ (in seconds)} = 58.82 \sqrt{H \text{ (in feet)}} \quad (372D)$$

An approximate formula is frequently of sufficient practical accuracy

$$Dip \text{ (in minutes)} = \sqrt{H \text{ (in feet)}} \quad (372E)$$

The last two formulas are used more often with oblique aerial photographs than with horizontal photographs. Dip angles are tabulated in table 3.3 based on equation 372D.

TABLE 3.3—The dip of the apparent horizon

Flying height <i>H</i> in thousands of feet	<i>DIP</i> angle	Flying height <i>H</i> in thousands of feet	<i>DIP</i> angle
	° / "		° / "
1	0 31 00	21	2 22 04
2	0 43 50	22	2 25 24
3	0 53 42	23	2 28 41
4	1 02 00	24	2 31 52
5	1 09 19	25	2 35 00
6	1 15 56	26	2 38 05
7	1 22 01	27	2 41 05
8	1 27 41	28	2 44 02
9	1 33 00	29	2 46 56
10	1 38 02	30	2 49 48
11	1 42 49	31	2 52 36
12	1 47 24	32	2 55 22
13	1 51 57	33	2 58 04
14	1 56 00	34	3 00 46
15	2 00 04	35	3 03 24
16	2 04 00	36	3 06 01
17	2 07 49	37	3 08 34
18	2 11 31	38	3 11 06
19	2 15 08	39	3 13 36
20	2 18 38	40	3 16 04

$$Dip \text{ (in seconds)} = 58.82 \sqrt{H \text{ (in feet)}}$$

The depression of the shoreline at different distances from an elevated point of observation is shown in table 3.4 which values are also corrected for curvature and refraction.

<sup>8</sup> Special Publication No. 143, Hydrographic Manual, U. S. Coast and Geodetic Survey, 3362, page 228

<sup>9</sup> American Society of Photogrammetry, Manual of Photogrammetry, 1944, page 579

TABLE 3 4—*Depression of the shoreline at different distances from the camera*

Distance <i>M</i> to land in meters	Height <i>H</i> of camera above sea in feet							
	5	10	15	20	25	30	35	40
	<i>D</i> in minutes							
500	11	21	32	42	52	63	73	84
600	9	18	26	35	44	52	61	70
700	8	15	23	30	38	45	53	60
800	7	13	20	26	33	39	46	53
900	6	12	18	23	29	35	41	47
1,000	5	11	16	21	26	32	37	42
1,100	5	10	15	19	24	29	34	38
1,200	5	9	13	18	22	26	31	35
1,300	4	8	12	16	20	24	28	33
1,400	4	8	12	15	19	23	27	30
1,500	4	7	11	14	18	21	25	28
1,600	4	7	10	13	17	20	23	27
1,700	3	7	10	13	16	19	22	25
1,800	3	6	9	12	15	18	21	24
1,900	3	6	9	11	14	17	20	22
2,000	3	6	8	11	14	16	19	21
2,500	3	5	7	9	11	13	15	17
3,000	2	4	6	8	9	11	13	15
3,500	2	4	5	7	8	10	11	13
4,000	2	4	5	6	7	9	10	11
5,000	2	3	4	5	6	7	8	10
6,000	2	3	4	5	6	7	8	8
7,000	2	3	4	5	5	6	7	8
8,000	2	3	4	4	5	6	6	7
9,000	2	3	4	4	5	6	6	7
10,000	2	3	4	4	5	5	6	7

$$D \text{ (in minutes)} = \frac{10.47 (H + c) \text{ (in feet)}}{M \text{ (in meters)}}$$

### 373 THE HIGH OBLIQUE PHOTOGRAPH

The chief advantages in the use of high oblique photographs in mapping consist of the facts that a very large area is shown in each photograph and that the tilt and swing can be determined from the image of the horizon line and a knowledge of the flying height with a relatively small amount of effort. High oblique photographs are usually employed in making small scale or reconnaissance maps or for special purposes such as control identification and military interpretation. Several methods and instruments are available for use in compiling the detail from oblique photographs onto a map manuscript, some of which are mentioned briefly here. The principal problems concerning high oblique photographs that are discussed here are the determination of the tilt data, two graphic methods for the determination of horizontal angles from the photographs, the graphic determination of vertical angles, and the construction of the perspective (Canadian) grid.

#### 3731 Determination of Tilt Data

The determination of the tilt data for a high oblique photograph consists in locating the apparent horizon line and the principle line, computing the apparent depression angle of the photograph perpendicular (camera axis), correcting the depression angle for angle of

dip, and locating the true horizon line. The flying height as indicated by the flight records is considered as being correct for the determination of horizontal angles and for the initial determination of vertical angles because a moderate error in the assumed flying height causes a very small error in the location of the true horizon line. The assumed flying height might require an adjustment later for use in determining elevation. It is assumed here that the apparent horizon is a clearly visible, slightly curved line extending from one side of the photograph to the other (figs 3 60 and 3 61). The apparent horizon is the image of the apparent junction of the earth and sky where the surface of the earth consists essentially of a plain or water. The apparent horizon *line* is the straight line that is tangent to the curved line. The principal point is at the intersection of the two lines that join opposite pairs of fiducial marks. The principal line is the perpendicular to the apparent horizon line that passes through the principal point. The orientation of the apparent horizon line is such that its departure from the curved horizon is equal at equal distances from the principal line. The tangent line is usually not parallel to the edge of the photograph.

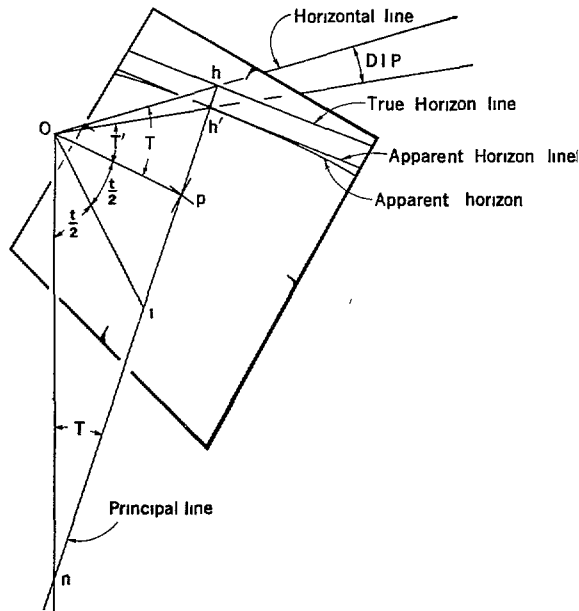

FIGURE 3 60—Geometry of the high oblique photograph

The apparent depression  $T'$  of the photograph perpendicular is the angle  $h'O p$  in the right triangle  $h'O p$  in which

$$\tan T' = \frac{h'p}{Op} = \frac{h'p}{f} \tag{3731A}$$

where  $Op$  is the focal length of the camera. Thus the apparent depression angle  $T'$  can be determined by measuring the distance  $h'p$  from the apparent horizon to the principal point, dividing by the focal length, and obtaining the angle from trigonometric tables.

The *dip* of the horizon was discussed in 372. The number of minutes of dip is merely equal to the square root of the flying height in feet, or the dip can be determined



directly from table 3.3 The true depression angle of the photograph is then the sum of the apparent depression and the dip

$$T = T' + dip \quad (3731B)$$

In the right triangle  $hpO$ ,  $T$  and  $f$  are known, whence,

$$ph = f \tan T \quad (3731C)$$

Thus the distance  $ph$  from the principal point to the true horizon line can be computed and the point  $h$  can be plotted on the photograph. The true horizon line is then the line through  $h$  that is parallel to the apparent horizon line. This completes the determination of the tilt data, and equations 3731A, B, C, and 372C are in common usage.

It should be noted that the inclination  $T$  of the oblique photograph and the tilt  $t$  are complementary angles

$$T + t = 90^\circ \quad (3731D)$$

The distances from the principal point to the nadir point and the isocenter were shown previously to be

$$pn = f \tan t \quad (3422A)$$

$$pi = f \tan \frac{t}{2} \quad (3422B)$$

However, the isocenter is more often located on oblique photographs by determining the distance from  $h$  in terms of  $T$

$$hi = \frac{f}{\cos T} = f \sec T, \quad (3731E)$$

which is now derived. In the right triangle  $Op h$ ,

$$\cos T = \frac{Op}{Oh}, \quad Oh = f \sec T$$

In triangle  $hOi$ ,

$$\text{angle } hOi = T + \frac{t}{2} = 90^\circ - t + \frac{t}{2} = 90^\circ - \frac{t}{2}.$$

In the right triangle  $Op i$ ,

$$\text{angle } hiO = 90^\circ - \frac{t}{2}$$

because the sum of the angles of any triangle is  $180^\circ$ . Hence, the angles  $hOi$  and  $hiO$  of triangle  $hOi$  are equal, the triangle is isosceles and the sides opposite the equal angles are equal, or

$$hO = hi = f \sec T,$$

and equation 3731E is verified

A possible alternative equation for locating the nadir point is

$$hn = \frac{Oh}{\sin T} = f \sec T \csc T, \tag{3731F}$$

which follows directly from the right triangle  $hOn$ . Also,

$$pn = \frac{f}{\tan T} \tag{3731G}$$

from equations 3731D and 3422A

3732 *Graphic Determination of Horizontal Angles*

Horizontal angles at the perspective center subtended by objects can be obtained from oblique aerial photographs by graphic construction by either of two methods. Let  $a$  (fig 3 61) be the image of an object  $A$  on an oblique photograph for which the true horizon line has already been located by the procedure of 3731.

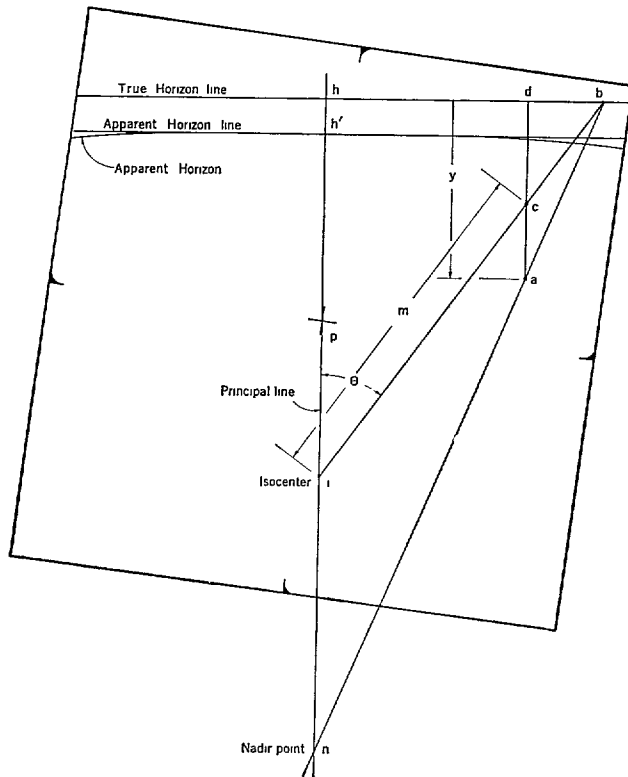

FIGURE 3 61—Horizontal and vertical angles from an oblique photograph

*First Method*—Locate the nadir point  $n$  and the isocenter  $i$  (3731). Construct a line from  $n$  through  $a$  so that it intersects the true horizon line at  $b$ . Draw the line  $ib$ . The angle  $\theta = \angle ibn$  is the correct horizontal angle at the perspective center between the principal plane of the photograph and the object  $A$ . This angle is equal to the horizontal angle that might have been measured with a transit or theodolite at  $O$  or  $N$  (fig 3 62) between the objects  $A$  and  $P$ . The horizontal angle between any two objects can be determined by proceeding in the same manner for both images, for which the correct horizontal angle is the angle at  $i$  subtended by the two points like  $b$  on the horizon line.

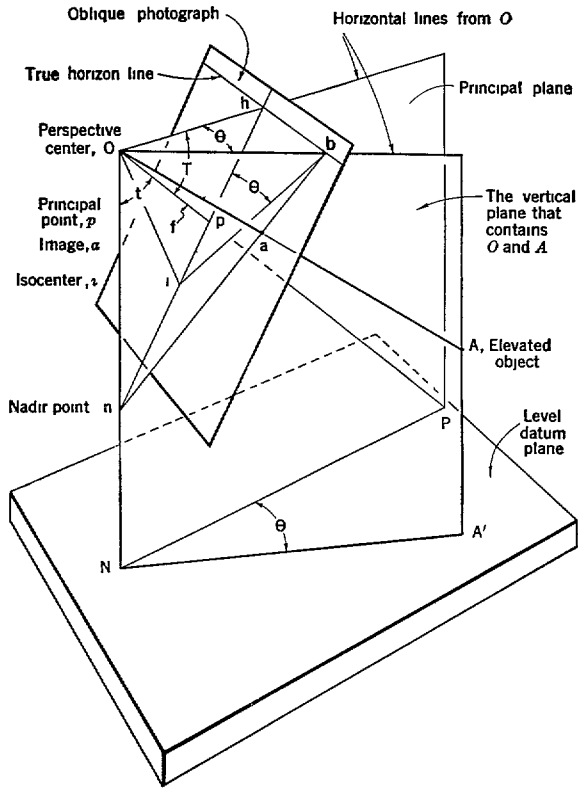

FIGURE 3 62—Horizontal angle from an oblique photograph

This method is the principal fundamental that underlies the trimetrogon procedure of photogrammetric mapping. In particular, the rectoblque plotter is an instrument that provides a direct mechanical solution of the *First Method*. Horizontal angles can also be determined from oblique photographs with the photoalidade, which instrument is more costly than the rectoblque plotter.

By the use of the graphic methods for determining horizontal angles, it is possible to construct a line or ray for each significant image on an oblique photograph and the lines radiate correctly from  $O$  or  $N$  although the point  $i$  is used in the construction. The rays might be in the form of lines on a transparent material, or slots in steel arms, and such an assembly of rays is called a radial templet in either case. A radial templet made from an oblique photograph differs in appearance from a templet from a vertical photograph because the rays of the oblique photograph radiate in one general direction from the radial center rather than throughout a full circle. However, in trimetrogon mapping, three cameras are used to take photographs simultaneously in which two of the cameras are used to take oblique photographs to the right and left of the aircraft, and the third camera is used to take a photograph vertically downward. There is a strip of overlap between the center photograph and each of the obliques, in addition to the fact that the relative orientations of the cameras may be accurately known. Inasmuch as each of the three cameras has in effect a common perspective center  $O$ , then a single templet can be constructed to incorporate the rays from all three photographs. Templets from several trimetrogon sets can then be assembled and adjusted to fit ground control as in radial plotting with vertical

photographs (325 and 425) The assembled radial plot indicates the correct positions of objects by the intersections of corresponding rays from the various templates, and the plot also indicates the correct position of each perspective (radial) center and the orientation of the principal line of each oblique template Templates from oblique photographs alone can, of course, be used without incorporating other templates with them

Figure 3 62 illustrates the basis for the procedure The angle  $\theta$  at  $N$  subtended by the objects  $A$  and  $P$  is the horizontal angle that might have been measured with a ground surveying instrument The point  $N$  is the ground nadir point vertically beneath the perspective center  $O$  Then the angle  $\theta$  is also the angle  $hOb$  at  $O$  where the planes  $ONP$  and  $ONA$  are vertical planes But the angle  $hOb$  is equal to angle  $hnb$  because, in the right triangle  $Ohb$ ,

$$\tan \theta = \tan hOb = \frac{hb}{hO},$$

and in the right triangle  $ihb$ ,

$$\tan hnb = \frac{hb}{hi}$$

But it is shown in 3731 that  $hi = hO$ , whence  $\tan hnb = \tan \theta$ , and angle  $hnb = \theta$  Thus, the *First Method* is justified

*Second Method*—A second method can be used where the nadir point  $N$  falls an inconveniently long distance off the photograph, which occurs if the angle of depression  $T$  is small (less than  $25^\circ$ ) The procedure is as follows (fig 3 61) (1) locate the isocenter  $i$ , (2) set a pair of proportional dividers so that one pair of points spans the distance  $hp$  when the other pair of points are set to span the distance  $hi$ , (3) drop a perpendicular line  $ad$  from the image to the horizon line, (4) locate the point  $c$  on  $ad$  with the proportional dividers so that  $\frac{dc}{da} = \frac{hp}{hi}$ , and draw the line  $ic$  Then the angle  $huc = \theta$  is the same correct angle as determined by the *First Method* If proportional dividers are not available, the distance  $dc$  can be computed from

$$dc = da \sin T$$

where  $da$  is measured, the angle  $T$  having been determined in the location of the true horizon line (3731), and the point  $c$  can be plotted

In figure 3 63, let  $ad$  be perpendicular to the horizon line, and let  $c$  be the intersection of  $ib$  with  $da$  The proof of the *First Method* shows that  $\theta$  is the angle  $icb$  makes with the principal line The right triangles  $adb$  and  $cdb$  are similar, respectively, to triangles  $nbn$  and  $ihn$  because their sides are parallel (or collinear) Then the lengths of their sides can be placed in the following proportions

$$\frac{da}{hn} = \frac{bd}{bh} \text{ and } \frac{dc}{hi} = \frac{bd}{bh}$$

Equating the left members and rearranging the proportion algebraically,

$$\begin{aligned} \frac{dc}{hi} &= \frac{da}{hn} \\ \frac{dc}{da} &= \frac{hi}{hn} \end{aligned} \tag{3732A}$$

In the right triangle  $hpO$ ,

$$\sin T = \frac{hp}{hO},$$

$$hO = \frac{hp}{\sin T} = hi, \tag{3732B}$$

inasmuch as  $hO$  and  $hn$  are equal. In the right triangle  $hOn$ ,

$$\text{angle } hnO = T$$

$$\sin T = \frac{hO}{hn}, \quad hn = \frac{hO}{\sin T} = \frac{hn}{\sin T}. \quad (3732C)$$

Substituting equations 3732B and C in A,

$$\frac{dc}{da} = \frac{\frac{hp}{\sin T}}{\frac{hn}{\sin T}} = \frac{hp}{hn} = \sin T,$$

which justified the *Second Method*. It is significant that, from equations 3732B and C,

$$\frac{hn}{hn} = \frac{hp}{hi} = \sin T$$

### 3733 Graphic Determination of Vertical Angles

Vertical angles to objects can be determined from oblique photographs by graphic construction. The vertical angles are in the form of angles of depression from the true horizon downward to the object. The tangent of the vertical angle of depression for any image such as  $a$  (fig. 361) is obtained as follows: (1) construct  $ad$  perpendicular to the true horizon line  $hd$ , (2) locate the point  $c$  on  $ad$  by either the *First* or *Second Method* of 3732, (3) measure the lengths of  $ad$  and  $ic$ , and (4) compute the tangent of the angle using the formula

$$\tan \alpha = \frac{ad \cos T}{ic} \quad (3733A)$$

The angle  $\alpha$  itself is usually not required because its tangent is only used for subsequent elevation determination. Inasmuch as the symbol  $y$  has been used for the length  $ad$ , and the symbol  $m$  for the length  $ic$ , the equation can be expressed as

$$\tan \alpha = \frac{y \cos T}{m} \quad (3733B)$$

(Note that equation 3733A is a general form of the special equation 3713C in which  $T$  is zero.)

The graphic determination of vertical angles is seldom performed in practice—the photoalidade is almost always used for this purpose. The graphic procedure is apt to be somewhat inaccurate because a small error in the measurement of the value of  $y$  causes an objectionably large error in the elevation of the object, whereas the instrumental procedure results in an angle as nearly correct as can be obtained from the photograph. Moreover, the instrumental method is faster and adjustments for the use of ground control can be readily applied.

In figure 363 is shown the image  $a$  of the object  $A$  and the vertical angle of depression  $\alpha$  that might have been measured at  $O$  with a transit or theodolite. The points  $b$ ,  $d$ , and  $c$  are determined by construction as in the *Second Method* of 3732. The line  $ae$  is constructed so that it is perpendicular to the line  $Ob$ . Then the angle  $\alpha$  is the angle  $eOa$  and

$$\tan \alpha = \frac{ae}{Oe} \quad (3733C)$$

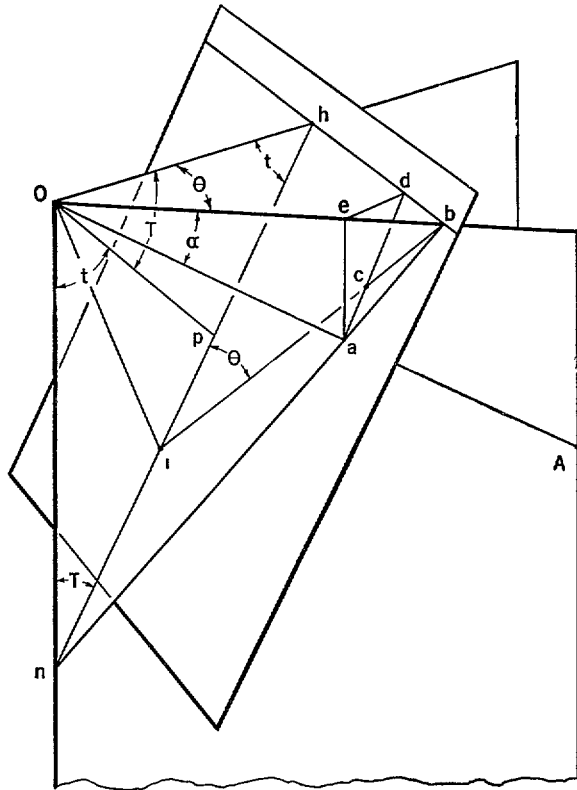

FIGURE 3 63 —Vertical angle from an oblique photograph

Let  $aed$  be a plane constructed through  $a$  and  $d$  parallel to the principal plane  $nOh$ . Lines  $ad$  and  $nh$  are parallel because they are both perpendicular to the horizon line  $hb$  and both lie in the plane of the photograph. Lines  $ae$  and  $nO$  are parallel because they are lines of intersection of the vertical transverse plane  $Obn$  with the two parallel planes  $aed$  and  $nOh$ . Also lines  $ed$  and  $Oh$  are parallel because they are lines of intersection of the horizontal transverse plane  $Ohb$  with the two parallel planes  $aed$  and  $nOh$ . Therefore, triangle  $aed$  is similar to the right triangle  $nOh$ , angle  $aed = 90^\circ$  and angle  $ead = T$ . Then in the right triangle  $aed$ ,

$$ae = ad \cos T = y \cos T \tag{3733D}$$

The figures  $Ohdbe$  and  $ihdbc$  are congruent or equal because  $hu = hO$ , angle  $hnb =$  angle  $hob$ ,  $h$ ,  $d$ , and  $b$  are common points, and  $di$  and  $de$  are both perpendicular to  $hd$ . Thus,

$$Oc = ic = m$$

Equation 3733B is derived by substituting equations C and D in A

### 3734 Elevations from Oblique Photographs

The elevation  $h$  of an object can be determined from oblique photographs by the use of the equation

$$h = H - \frac{My \cos T}{m} + c \tag{3734A}$$

where  $H$  is the flying height of the aircraft,  $M$  is the horizontal ground distance from the camera station ( $O$  or  $N$ ) to the object,  $y$ ,  $T$ , and  $m$  are values determined in **3732** and **3733**; and  $c$  is the correction for curvature and refraction that is discussed in **372**. The factor  $\frac{y \cos T}{m}$  is the tangent of the vertical angle of depression derived in **3733**, for which  $\tan \alpha$  might well be substituted inasmuch as  $\alpha$  might be measured with a photoalidade

$$h = H - M \tan \alpha + c \quad (3734B)$$

The value  $M \tan \alpha$  is obviously the vertical distance from the horizon plane downward to the object by plane trigonometry. The inverse of equation *3734B* gives the flying height of the aircraft in terms of the known elevation of a ground control point

$$H = h + M \tan \alpha - c \quad (3734C)$$

The value of  $M$  in any of these equations can be obtained from a radial plot using two or more templets constructed graphically from the oblique photographs using one of the methods of **3731**.

The values for elevations of objects will not be very accurate if these equations are used without adjusting the values of  $H$  and  $T$  and the orientation of the principal line to fit at least three well-distributed ground control stations not in a straight line (**3735**).

### 3735 Adjustment of Tilt Data to Fit Control

Elevations determined graphically from high oblique photographs are frequently in error due to two principal causes, namely, (1) the horizon line may have been incorrectly located because it is often not sufficiently distinct, and (2) the assumed flying height may be in error. Neither of these sources of error causes much difficulty insofar as horizontal angles and radial distances are concerned, but the errors are very important where elevations are to be determined. A method for adjusting the horizon line and the value of the flying height was developed by Mr R. M. Wilson (see footnote in **37**) but a later method has been devised by the trimetrogon group of the Geological Survey in connection with the operation of the photoalidade, and this later method is presented here. The complete theory and application are fully explained in a forthcoming publication<sup>10</sup>. The method is applicable to both graphic and instrumental operations where there are three or more well-distributed control stations not in a straight line on a photograph. The elevations of the control stations must be known, but horizontal positions are sufficiently accurate if they are the result of a radial plot made from the same oblique photographs using a trial horizon line. The method is applicable to both high and low oblique photographs. Although the instrumental method is much simpler, more direct, and more accurate, the graphic method is presented here because of its application to the uses of the Coast and Geodetic Survey.

The graphic procedure is begun by making a templet from the oblique photograph using the second method of **3732** based on a logical location of the horizon line, and fitting the templet to the control points that have been plotted on a control sheet or projection. Equation *3734C* is used to determine the apparent values of the flying height  $H'$  at each of the control points, and the values of  $m$ ,  $M$ , and  $y$  are measured on the photograph or on the controlled templet. The three apparent values of the flying height usually differ from one another, indicating that the horizon line was incorrectly positioned. The

<sup>10</sup> Reconnaissance Mapping with Trimetrogon Photographs, U. S. Air Force, forthcoming publication  
837982°—50—17

three values can also be considered as the heights at three points of a sloping plane in space. The slope of the plane is caused by the erroneous horizon line—the plane should be horizontal, hence the three heights should be equal. Moreover, the correct height of the sloping plane is at the perspective center. The isocenter on the templet is effectively the perspective center and radial center because of the graphic construction.

The height of the radial center of the sloping plane is determined by graphic interpolation from the three heights by the same method that was used with scale points in tilt determination (352). The three heights are designated  $H_1'$ ,  $H_2'$  and  $H_3'$ , where the first is the smallest of the three values and the last is the largest. The graphic interpolation is performed on the radial templet as follows (see fig. 364):

- 1 Connect the two control points that have the largest and smallest height values with a line and measure its length  $H_1'H_3'$ .
- 2 Locate a point  $k_1$  on the line so that this point has the height value  $H_2'$ , where

$$H_1'k_1 = H_1'H_3' \frac{H_2' - H_1'}{H_3' - H_1'} \quad (3735A)$$

- 3 Construct a line through the radial center parallel to the line through the points  $H_2'$  and  $k_1'$ , and designate the point of intersection with the line  $H_1'H_3'$  by  $k_2'$ .
- 4 Measure the distance from  $H_1'$  to  $k_2'$  and apply the proper algebraic sign—if  $k_2'$  is the same direction from  $H_1'$  as  $H_3'$  is, the sign is plus.
- 5 Compute the height of the radial center.

$$H = H_1' + (H_3' - H_1') \frac{H_1'k_2}{H_1'H_3'} \quad (3735B)$$

The apparent error  $\Delta H$  in each of the computed heights is then determined by subtraction:

$$\Delta H = H' - H \quad (3735C)$$

The required change  $\Delta y$  in the position of the horizon line at each of three points on the photograph can then be computed by using the equation:

$$\Delta y = \frac{m \Delta H}{M \cos T} \quad (3735D)$$

The increment  $\Delta y$  is applied where the perpendicular from the image intersects the horizon line that is constructed during the preparation of the templet.

Equation 3735D is derived from equation 3734A. Solving for  $H$ ,

$$H = \frac{M \cos T}{m} v + h - c$$

Applying differential calculus, regarding  $H$  and  $y$  as variables,

$$dH = \frac{M \cos T}{m} dy$$

If  $\Delta H$  and  $\Delta y$  are small changes in the values of  $H$  and  $y$ , they can be substituted for  $dH$  and  $dy$ , and the solution for  $\Delta y$  results in equation 3735D.

The method, using three control stations, is illustrated with a numerical example and figure 364. The given data are stated in the tabulation. It is assumed that a radial templet has been made from an oblique photograph, using a logical position for the horizon line and a logical value for the flying height, that the second method of 3732 was used, and that the vertical angles have been constructed graphically according to 3733. It is also assumed that the radial templet has been adjusted to fit plotted positions of the control points as



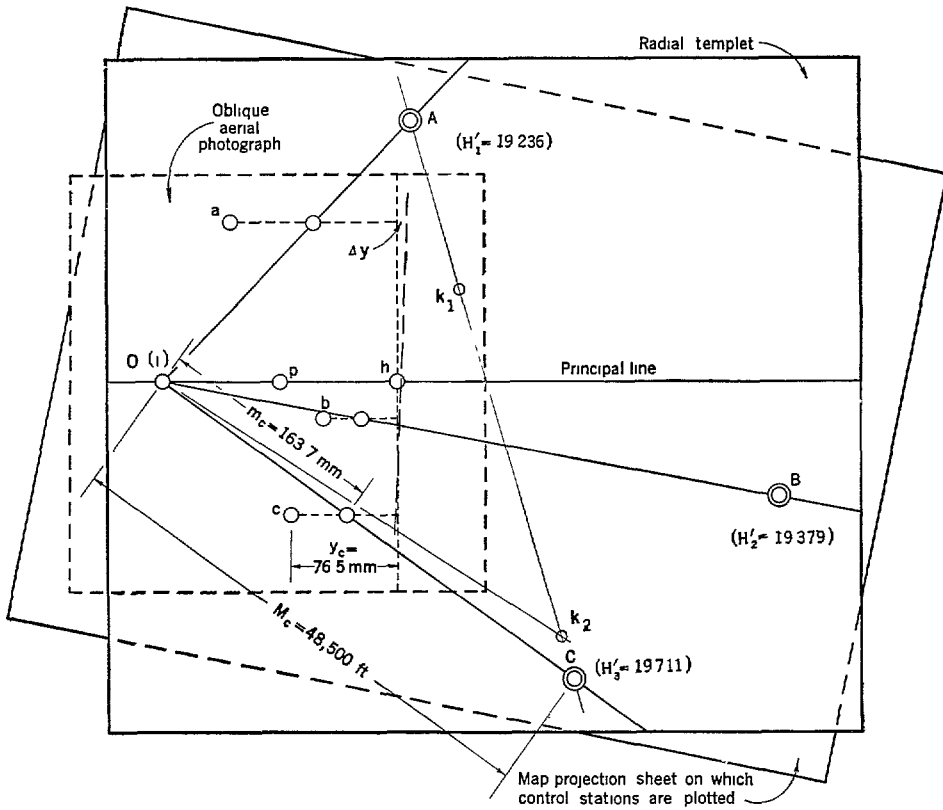

FIGURE 3 64 —Adjustment of the horizon line

shown in the figure. The values of the  $y$ 's,  $m$ 's,  $M$ 's,  $H_1'H_3'$ ,  $H_1'k_1$ , and  $H_1'k_2$  are scaled from the photograph itself and from the templet as it lies on the control sheet. The scale of the control sheet is applied to the scaled values of the  $M$ 's, and the values of the  $c$ 's are taken from table 3 2 and based on the corresponding values of  $M$ .

$f = 150 \text{ mm}$

$T = 29^\circ 20'$

$\cos T = 0.87178$

	$M$	$y$	$m$	$\frac{My \cos T}{m}$	$h$	$c$	$H'$
	<i>feet</i>	<i>mm</i>	<i>mm</i>	<i>feet</i>	<i>feet</i>	<i>feet</i>	<i>feet</i>
A	28,290	114.3	163.4	17,252	2,000	-16	19,236
B	61,000	-41.4	152.3	14,456	5,000	-77	19,379
C	48,500	76.5	163.7	19,759	0	-48	19,711

$H_1'H_3' = 262.0 \text{ mm}$

$H_1'k_1 = 262.0 \times \frac{19379 - 19236}{19711 - 19236} = 78.9 \text{ mm}$

$H_1'k_2 = +199.5 \text{ mm}$

$H = 19236 + (19711 - 19236) \frac{199.5}{262.0} = 19598 \text{ feet}$

	$\Delta H$	$\Delta y$	New $y$	$\frac{My \cos T}{m}$	$H$
	<i>Feet</i>	<i>mm</i>	<i>mm</i>	<i>Feet</i>	<i>Feet</i>
<i>A</i>	+ 362	+ 2.4	116.7	17588	19572
<i>B</i>	+ 219	+ 0.6	42.0	14644	19567
<i>C</i>	- 113	- 0.4	76.1	19626	19578

Sample computations

$$\Delta H = 19598 - 19236 = + 362 \text{ feet}$$

$$\Delta y = \frac{163.4 \times 362}{28,290 \times 0.87178} = 2.4 \text{ mm}$$

In the initial computation,

$$\frac{My \cos T}{m} = \frac{28,290 \times 114.3 \times 0.87178}{163.4} = 17,252 \text{ feet}$$

$$H' = 17252 + 2000 - 15 = 19,236 \text{ feet}$$

In the final computation,

$$\frac{My \cos T}{m} = \frac{28,290 \times 116.7 \times 0.87050}{163.4} = 17,588 \text{ feet}$$

(After applying the  $\Delta y$  corrections to the photograph, the value of  $T$  is redetermined as in **3731**. The new value of  $T$  is  $29^\circ 29'$  whose cosine is 0.87050.)

$$H = 18,588 + 2000 - 16 = 19,572 \text{ feet}$$

Thus the horizon line is adjusted so that the three final values of  $H$  are almost equal. The average of the final values is considered to be a better value of  $H$  than 19,598 which was determined by graphic interpolation.

The general method is even easier to apply in the operation of the photoalidade. Differentiating equation 3734C with respect to the variables  $H$  and  $\alpha$  and solving for  $d\alpha$ ,

$$dH = M \sec^2 \alpha d\alpha$$

$$d\alpha = \frac{dH \cos^2 \alpha}{M}$$

Inasmuch as 1 minute of arc is equivalent to 0.000291 radians, the reciprocal of which is 3436, a small change  $\Delta\alpha$  can be expressed as

$$\Delta\alpha \text{ (in minutes)} = \frac{3436 \cos^2 \alpha \Delta H}{M} \quad (3735E)$$

This equation can be solved with a slide rule with sufficient accuracy. Moreover, the values of  $\cos^2 \alpha$  can be tabulated for each  $1^\circ$  of arc to avoid the use of a more bulky table.

To use the data,  $\Delta\alpha$  is added to the original value of  $\alpha$ , the sum of the two is set on the vertical circle of the photoalidade, the platen is inclined to change  $T$  until the image of the particular control station is on the crosshair, the telescope is raised until the reading on the vertical circle is zero, and a mark is made on the photograph where the crosshair seems to lie. This mark is one point on the corrected horizon line. The procedure is repeated for one or more other control points, locating two or more points on the photograph. The platen is then reoriented and the photograph is adjusted in swing to conform to the new horizon line. This completes the adjustment except for testing and checking the operation.

### 374 THE LOW OBLIQUE PHOTOGRAPH

Low oblique photographs which do not contain an image of the horizon are seldom used because of the difficulty in determining the tilt data, which is comparatively easy to obtain for a high oblique photograph

Like the tilt determination for near-vertical photographs, three well-distributed ground control stations are required to obtain the tilt data for a low oblique in which both the relative positions and elevations of the control stations are known. A tentative position for the true horizon line is selected and the computation of **3735** is made. Due to the fact that the tentative horizon line can be greatly in error, the resulting corrections are apt to be large and inaccurate, and a second, or even third, computation of **3735** is made using the adjusted location of the horizon line for each new computation. Otherwise, the procedure for using low oblique photographs is just the same as outlined for high obliques. Needless to say, the graphic methods have largely been replaced by the use of the photoalidade

In contrast to the procedure of using low oblique photographs, the tilt data can usually be determined for a high oblique photograph from the photograph itself so that horizontal positions of objects can be obtained by radial plotting with satisfactory accuracy without *any* vertical control and with only an occasional horizontal control station

### 375 THE PERSPECTIVE (CANADIAN) GRID <sup>11</sup>

A planimetric map of terrain of low relief can be compiled from an oblique aerial photograph by the use of a perspective grid. The perspective grid is a system of lines that is constructed for an oblique photograph where the lines represent corresponding lines of an imaginary rectangular grid on the ground. The grid can only be used where the area to be mapped is relatively flat because no accurate correction for relief displacement is applicable. The perspective grid is usually drawn on a transparent plastic sheet and superposed on the photograph, and the map is compiled by transferring photographic details to a rectangular (planimetric) grid by eye, estimating the position of each item of detail relative to the sides of the square in which it lies. (The use of the perspective grid for mapping large areas has been replaced by the use of the oblique sketchmaster. This instrument consists principally of a half-silvered prism by means of which it is possible for one to see the oblique photograph and the corresponding planimetric map at the same time, so that the photograph seems to be rectified and superposed correctly on the map. The operator is thus able to trace the photograph detail directly onto the map sheet.)

The rectangular grid on the ground is purely imaginary and a separate grid is constructed with respect to the values of the inclination  $T$  and the flying height  $H$  of each photograph. The grid spacing of the imaginary ground grid can be chosen to serve best the needs of compilation. The ground grid is always oriented so that one of the longitudinal grid lines is in the principal plane of the photograph. The accuracy of the grid is dependent on the accuracy of the value of  $H$  which can be adjusted to fit horizontal control, and the accuracy is usually not affected by a small error in the identification of the horizon line. Perspective grids are usually employed for relatively small-scale mapping, such as 1:60,000 or smaller. Perspective grids are customarily used only with high oblique photographs, but they can be used with low oblique photographs if sufficient control is available for the location and adjustment of the horizon line by some method such as **3735**.

<sup>11</sup> Topographical Survey Bulletin No. 62, Department of Interior, Dominion of Canada

In describing the construction of a perspective grid, it is assumed that an approximate value of  $H$  is known, that the value of  $T$  has been determined and the true horizon line has been located as in 3731. The subsequent steps are as follows (fig 3 65)

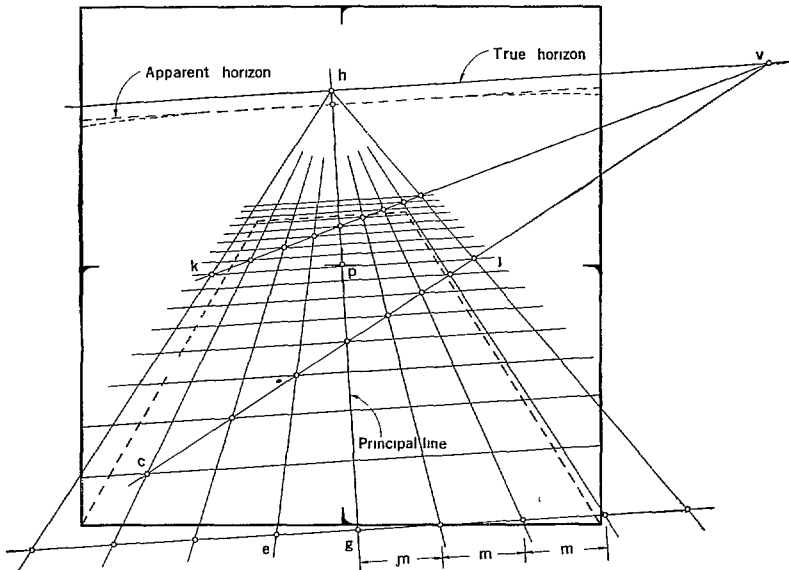

FIGURE 3 65 —Construction of the perspective grid

1 Select a convenient interval  $M$  for the imaginary ground grid, such as 1,000, 2,000, 5,000 feet, or 1,000 meters. Where a grid is being made for the first time, one may not know what interval to use. Hence, some one interval should be tried and changed later if it is found that the spaces of the perspective grid are too large to permit accurate compiling, or that the grid lines are so close together that they interfere with the plotting of detail.

2 Select a convenient interval  $m$  to be laid off on the line  $ge$ , such as 1 inch, one-half inch or 1 centimeter. The value of  $m$  should be some even division of a scale such that the point  $g$  (step 3) will lie about at the lower edge of the photograph. If  $g$  is closer to  $p$  than the edge of the photograph, some inaccuracy may result, whereas if  $g$  is very far below the edge of the photograph, the drafting operations are somewhat unwieldy.

3 Compute the distance  $hg$  from the relation

$$hg = \frac{mH}{M \cos T} \quad (375A)$$

4 Plot the point  $g$  on the principal line, construct the line  $ge$  perpendicular to  $hg$ , and lay off the intervals  $m$  on the line  $ge$  both to the right and to the left of  $g$ . The intervals can be accurately laid off by laying a scale on the line and marking the appropriate points opposite the divisions of the scale, whereas to lay off the intervals with a pair of dividers is apt to result in an accumulation of error.

5 Draw a line from each interval mark like  $e$  to the point  $h$ . These lines correspond to the imaginary longitudinal grid lines that are parallel to the principal plane. The point  $h$  is called the vanishing point for the longitudinal lines.

6 Compute the distance  $hv$  from the relation

$$hv = \frac{f}{\cos T} \quad (375B)$$

Plot the location of the point  $v$  on the horizon line either to the right or to the left of  $h$ . The point  $v$  is the vanishing point for all the grid diagonals that can be drawn from the left foreground to the right background, or vice versa.

7 Construct a random straight line  $vc$  diagonally across the photograph. It is usually convenient to draw  $vc$  approximately to the opposite lower corner of the photograph. It is not necessary to draw the line through  $\beta$ ,  $g$ , nor any other specific point. The line  $vc$  then represents a 45°-diagonal line across the grid, and the intersection with each line of step 5 is a grid intersection.

8 Construct lines parallel to the horizon line through each intersection on the line  $vc$ . These lines represent the imaginary transverse ground grid lines that are perpendicular to the principal plane. If more lines are desired above the point like  $j$ , construct another line  $vk$  to a grid intersection at the opposite end of the last transverse line. Then more transverse lines can be constructed through the intersections of  $vk$  with the longitudinal lines. This completes the construction of the perspective grid.

9 With the perspective grid traced on a transparent material, lay the grid on the photograph so that the points  $h$  and  $\beta$  coincide. Then construct a separate rectangular planimetric grid to represent a map of the imaginary ground grid—ordinary graph paper will usually suffice. A grid square of the planimetric grid should be about the same size as the largest grid space of the perspective grid, and there is ordinarily no reason for the squares to be much larger than that. The scale of the planimetric grid is obviously

$$S = \frac{m'}{M} \quad (375C)$$

where  $m'$  is the distance between two adjacent lines of the planimetric grid.

10 Draw the map detail on the planimetric grid, estimating the position of each feature within its corresponding square. Ordinarily, the usable area of a high oblique photograph consists approximately of a trapezoid (dotted line in the figure) whose base is the lower edge of the photograph, whose other parallel side is a transverse line a short distance (1 inch) above the principal point, and whose non-parallel sides extend from the lower corners of the photograph toward  $h$ . The transferred detail represents a planimetric map of the photographic detail.

11 The perspective grid can be adjusted to fit horizontal ground control if the images of two ground control stations can be identified on the photograph. The two images can be transferred from the photograph to the planimetric grid and ground distance measured, applying the scale of equation 375C. The correct flying height  $H$  of the camera is then given by the equation

$$H = \frac{H'D}{D'}$$

in which  $H'$  is the trial value of the flying height that was used in the initial determination of the tilt data and in the construction of the grid,  $D$  is the known horizontal distance between the two ground points, and  $D'$  is the corresponding distance obtained from the perspective grid. Another perspective grid should then be constructed using the value of  $H$ .

12 A perspective grid constructed for one photograph can frequently be used also with other photographs in the same area because small changes in the values of  $H$  and  $T$  do not seriously affect the accuracy of the compilation. Consequently, it is sometimes possible to construct a set of perspective grids where the values of  $H$  and  $T$  differ by appropriate intervals, such as 200 feet for  $H$ , and 30 minutes for  $T$ .

13 A map can be compiled by assembling the compilations of the separate photographs. It should be obvious that the planimetric grid for one photograph will differ from that of another photograph inasmuch as the principal planes of the two photographs are not related in any way and no attempt is made to have a grid intersection of one photograph coincide with that of another photograph. The scale of the planimetric grids is the only characteristic that is common to them. Consequently, the detail could be transferred in step 10 to a translucent sheet that overlaps the planimetric grid, instead of being transferred to the grid itself.

14 To assist in maintaining the proper angular relationship of the compilation from one photograph to that of another, a straight random line can be drawn on one photograph extending from the utilized area across an area of detail that is compiled from an adjoining photograph, and the line compiled onto both the planimetric grids along with the photographic detail. Because a straight line in flat terrain appears as a straight line on any photograph of it, then the images through which the line passes must be on the same line on the assembly of the separate planimetric compilations. Images of unmistakable identification can be selected through which to draw the line, although the images may lie outside the area of compilation.

Figure 3 65 is an example of the construction of a perspective grid. The focal length of the camera is 200 mm, the angle of inclination  $T$  is  $22^\circ 06'$ , and the computation is based on a flying height of 10,000 feet. A ground grid interval  $M$  of 5,000 feet, and a photograph interval  $m$  of 20 mm were selected. Then  $hg$  is computed from equation 375A

$$hg = \frac{10,000 \times 20}{5,000 \times 0.92653} = 43.17 \text{ mm}$$

The point  $g$  is located 43.16 mm from  $h$  on the principal line,  $ge$  is constructed perpendicular to the principal line, and the intervals of 20 mm each are laid off with a metric scale in contact with the line  $ge$ . The distance  $hv$  is computed from equation 375B

$$hv = \frac{200}{0.92653} = 215.86 \text{ mm}^\circ$$

The remainder of the construction is performed as outlined.

The theory of the perspective grid is illustrated by figure 3 66. The theory is based on the well-known principle of perspective drawing, that parallel lines in an object are shown in the drawing as intersecting at a common point, called the vanishing point. More specifically, parallel *horizontal* lines are shown as intersecting at a vanishing point on the image of the horizon on a perspective drawing. The transverse lines constitute a special case in which the vanishing point on the horizon line is an infinite distance to the right (or left) and therefore the transverse lines are drawn parallel to the horizon line on the perspective grid.

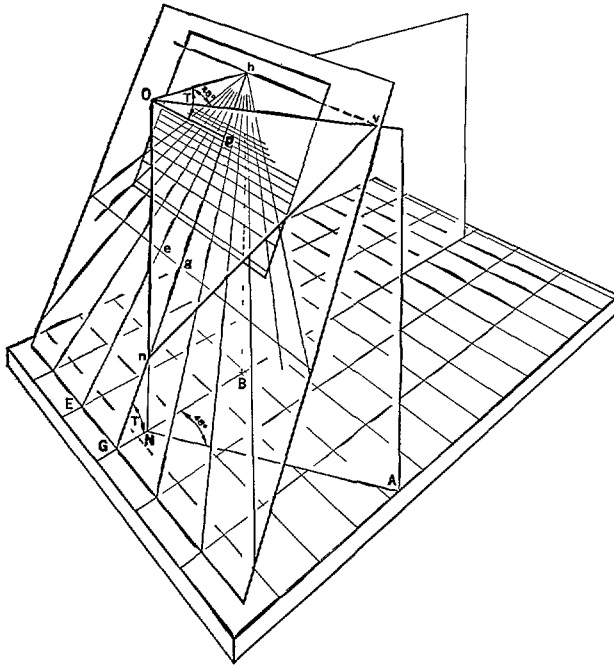

FIGURE 3 66—Theory of the perspective grid

The images of a pair of extended parallel straight lines in the object space, such as the rails of a railway, are shown on any tilted photograph as two intersecting straight lines, unless the lines are perpendicular to the principal plane of the photograph. This is evident in view of equation 3441A,

$$S = \frac{f \sec t - y \sin t}{H}$$

in which  $t = 90^\circ - T$ , which indicates that the scale at points on a photograph becomes smaller as the  $y$ -distance from the nadir point toward the horizon becomes greater, whence the distance between the two lines diminishes as the  $y$ -dimension increases. The images of the two rails will intersect if the distance between them is zero, which occurs when the numerator of the right side of the equation is zero, or when

$$y \sin t = f \sec t$$

In the right triangle  $Opn$  of the figure,  $f$  is the distance from  $O$  to  $p$ , angle  $pOn = t$ , and  $On = f \sec t$ . However, angle  $Ohn$  of the right triangle  $hOn$  is also equal to  $t$  and  $y \sin t$  is equal to  $On$  if  $y = np$ . Therefore, at  $h$  and also at any other point on the horizon line, the scale is zero, and any pair of horizontal parallel lines must intersect on the horizon line. The principal line by definition is perpendicular to the horizon line and the intersection of the two is therefore fixed, but the principal line is also the image of one of the longitudinal lines of the imaginary ground grid. The image of any other longitudinal line must then intersect the image of the first one on the horizon line at  $h$ , whence the images of all the longitudinal lines will intersect at  $h$ .

The plane  $vhG$  is the plane of the photograph extended until it reaches the ground. Then there are two points on the image of each ground longitudinal line. One point at  $h$ , and the other point at the intersection, such as  $E$ , with the oblique plane and the ground line. Therefore the image of each longitudinal line on the perspective is determined, but a practical method for graphic construction is not yet derived.

By construction, the transverse lines at  $G$  and  $g$  are both parallel to the horizon line. Triangles  $hGE$  and  $hge$  are similar, and the following relation of the ratios of the corresponding sides can be expressed

$$\frac{hg}{hG} = \frac{ge}{GE}$$

But  $ge = m$ ,  $GE = M$ , and in the right triangle  $hBG$ ,

$$hG = hB \sec T = H \sec T$$

Then equation 375A is derived by substitution and by solving for the element  $hg$ , which enables a practical construction of the images of the longitudinal lines.

One set of diagonals of the ground grid squares is a set of parallel lines whose images must also intersect at a single point on the horizon line. If a point can be found where one of the set of diagonal lines meets the horizon line, that point will also be the vanishing point for all the diagonal lines of the set. The line  $NA$  is constructed parallel to one set of diagonals and the angle  $BNA$  is therefore  $45^\circ$ . The point of intersection of the image of the line  $NA$  with the horizon line of the photograph will necessarily be the intersection of the vertical plane that contains  $O$ ,  $N$ , and  $A$  with the horizon line. Whence the angle  $hOv$  is also  $45^\circ$ , and triangle  $Ohv$  is a right isosceles triangle with the right angle at  $h$  by construction. Therefore, the distance  $hv$  is equal to the distance  $hO$  which was shown to be equal to  $f \sec T$  following the derivation of equation 3731E.

## CHAPTER 4. RADIAL-PLOT PROCEDURES

This chapter includes detailed instructions for assembling a radial plot with vertical aerial photographs and the prior preparation of the photographs and the map manuscripts. Although the images on a vertical photograph are distorted because of relief and because of tilt, such a photograph is a nearly perfect record of directions from its radial center (usually assumed to be the principal point) to all images on the photograph. In radial plotting this fact is utilized to establish by graphic resection and intersection the relative positions of photograph centers and photogrammetric points. This procedure is known as radial plotting (see 42) and, in a general way, may be compared to graphic triangulation with a planetable. The purpose of a radial plot is to locate, with reference to one another, a number of points to control the surrounding map details during their delineation from the photographs.

An uncontrolled radial plot is made without reference to ground control, in which case the distances and directions between points established by the plot are relatively correct, but the scale ratio is only approximately known and neither geographic position nor orientation is known. To establish the exact scale ratio, the true orientation, and the positions in terms of geographic or ground coordinates, the plot must be referenced to ground control.

The use of the principal point as the radial center is an approximation, acceptable for accurate radial plotting only where differences in relief are less than 10 percent of the flight altitude and the tilt of the aerial camera is less than  $3^\circ$ , otherwise the midpoint, isocenter, or nadir point must be used as the radial center, as explained in chapter 3.

Radial plots of single-lens photographs are generally made by hand-templet or mechanical-templet methods, but may also be made by the direct method. Nine-lens photographs are plotted by the direct method or by hand templates—not by mechanical templates.

### 41 GENERAL PROCEDURES

Certain basic steps of procedure are common to the templet methods and must be followed to produce maps that meet the required standards of accuracy. In each step, accuracy is required to prevent an accumulation of error exceeding the specified tolerances. The methods, materials, and accuracies required in these basic steps are described in this section.

#### 411 PREPARATION OF OFFICE PHOTOGRAPHS

Single-lens and nine-lens office photographs are prepared in the same basic way for graphic and mechanical radial plots, except for the distribution and density of photogrammetric points and the dissimilarities of the two types of photographs.

##### 4111 *Indexing and Checking Photographs*

After the photographs have been checked against the transmitting letter and indexed properly (see 1541), each shall be inspected, with special attention given to nine-lens and ratio photographs.

An occasional photograph may be flat, indefinite, and characterless or may have too great a range of contrast. All unsatisfactory photographs shall be returned to the Washington Office with the imperfections plainly noted. The photographic laboratory will make improved prints, if possible.

##### 4112 *Radial Centers on Photographs*

The *radial center* is the point from which radials originate and may be the principal point, substitute center, nadir point, midpoint, or isocenter. (Throughout this chapter the



principal point is used as the radial center, unless otherwise stated ) Whichever point is to be used as the radial center shall be pricked and encircled with two concentric circles, 6 and 10 mm in diameter, in washable ink (see fig 5 42)

A small white cross marks the principal point on a nine-lens photograph Where this cross blends with the photograph detail so that it is invisible, the principal point has to be located by resection To do this, opposite wing chamber lines (see fig 4 1) are connected with a straightedge and a short line is drawn with a chisel-edged pencil along the straight-edge in the approximate center of the photograph Three such lines from different chamber lines will intersect at the approximate principal point and check the position

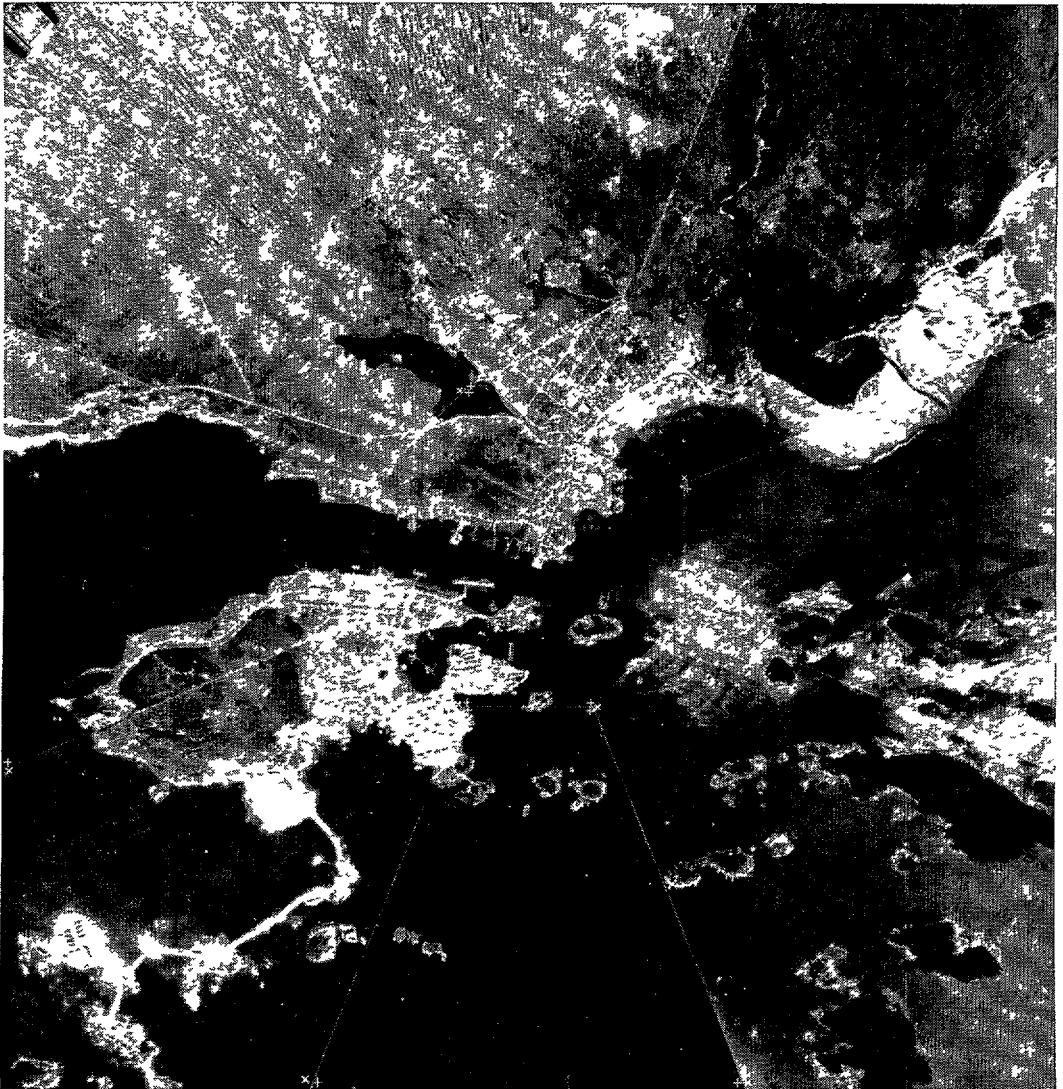

FIGURE 4 1—A nine lens photograph

On a single-lens photograph with the fiducial marks imaged on the four sides, the principal point is located at the intersection of lines joining these marks

If the conjugate center (see 4113) of a principal point cannot be accurately identified or the azimuth on adjacent photographs cannot be determined reliably, a substitute center should be used in lieu of the radial center. A *substitute center* is a readily identifiable point not more than 3 mm from the principal point and is used in lieu of the principal point where the latter cannot be accurately transferred to adjoining photographs

If photographs tilted 3° or more have to be used, either the isocenter or the midpoint must be used as the radial center. (See 3434 and 4212.)

#### 4113 Azimuth Lines on Photographs

An *azimuth line* is a radial from the radial center of a photograph to a conjugate radial center—that is, to the radial center of an overlapping photograph. Azimuth lines are used in a radial plot to assist in carrying forward an accurate azimuth from one photograph to another and to orient adjacent photographs during the assembly of a radial plot by holding common azimuth lines in coincidence

There are two methods of establishing azimuth lines—that is, (a) by establishing conjugate centers and then drawing the azimuth line between the radial center and conjugate center, and (b) by establishing the azimuth line without the conjugate center

(a) The image (or position with reference to surrounding detail) on one photograph of the radial center on an overlapping photograph is called the *conjugate center*. Where conjugate centers can be established accurately they furnish the most ready means of drawing the azimuth lines on the photographs. Because they must be marked with extreme accuracy, a magnifying glass and a stereoscope should be used in pricking them

Conjugate centers should be concentrically encircled with two concentric circles, 6 and 10 mm in diameter, using washable ink (see fig 5 42)

Where the radial center is on sharp identifiable detail, its conjugate centers can be pricked direct, otherwise its conjugate centers must be determined by using either a stereoscope or reference points

An experienced operator with considerable concentration can transfer the radial center direct while using a stereoscope, although this is a difficult procedure. Two photographs are adjusted to form a stereoscopic model (see chapter 3). When this model is adjusted perfectly and viewed stereoscopically, a pinhole marking the radial center of one photograph can be seen on the overlapping photograph and can be pricked direct. This is the conjugate center. Accurate pricking under the stereoscope requires that the photographic details around the point be clear and well-defined, otherwise exact correspondence cannot be established. In using this method, a stereoscopic check should be made after the conjugate center has been encircled. The circles can then be checked under the stereoscope to see that they are horizontal and on or near the ground

In a less difficult and more accurate stereoscopic method two small pieces of clear plastic approximately 0.2 mm thick are used. Two concentric circles 5 and 15 mm in diameter are finely etched on each piece of plastic, with a black dot at the exact center of one and a pinhole at the center of the other. After the two photographs have been adjusted and oriented as a stereoscopic model, the plastic with the dot is placed etched side down on the left photograph and the dot is superposed exactly over the radial center. Photographic detail within the larger circle is viewed through the stereoscope, and the photographs are readjusted to perfect the orientation. The second plastic with the pinhole is placed on the overlapping or right photograph and moved about until both circles and the dot and pinhole fuse and appear to rest exactly on the surface of the ground. When the right plastic is moved to the left, the circles will seem to rise and float above the ground, conversely, but less noticeably, the circles will seem to sink into the ground as the right plastic is moved to the right. When the operator is satisfied that the detail within the smaller circle and the dot and pinhole are perfectly fused and that the circles are apparently resting on the surface of the ground, a pinpoint is pricked through the pinhole into the photograph. This position of the conjugate center should be immediately verified by the operator

In determining conjugate centers by using reference points, only those points near the radial center and in approximately the same horizontal plane are selected if their images are identifiable on all appli-

cable photographs Three reference points are required for a position check and a fourth is recommended Distances are measured from the reference points to the radial center and transferred to the overlapping photographs where they are swung as arcs with a chisel-edged pencil point in a bow-spring compass The intersection of these arcs is the conjugate center on that photograph This method should be used with precaution as it is only applicable in flat terrain Further precaution is suggested with nine-lens photographs, because there are apt to be variable scale discrepancies where little tilt is combined with slight differences in elevation between the radial center and reference points

Where the scale differences of overlapping photographs appreciably affect the reference distances and especially in a water area where the reference points are along the shore, conjugate centers can be determined by using directions to reference points, instead of distances To use this method, the reference points and the radial centers must lie in the same horizontal plane A small piece of clear plastic sheeting is temporarily taped over the radial center of a photograph so that it lies flat and is secure With a sharp pricker the radial center is pricked in this templet and fine radial lines are etched through at least four nearby reference points surrounding the center This templet is then removed and oriented on an overlapping photograph so that the etched radials bisect their respective reference points Then the hole in the templet is over the conjugate center

The conjugate centers having been marked, fine azimuth lines are drawn from the radial center through all conjugate centers on each photograph The respective azimuth lines on overlapping photographs should be accurately compared and checked under a stereoscope to see that they pass through identical detail Generally all the conjugate centers cannot be accurately established or pricked Where this occurs it is generally better to leave them off and to establish the azimuth lines by other methods

(b) To establish an azimuth line without the use of conjugate centers on a pair of overlapping photographs, the two photographs are first placed side by side If an azimuth liner is used, it is placed on the photographs with the etched line next to the photographs and is held in position with the etched line bisecting the two radial centers while the photographs are rotated until the etched line passes through identical detail on both photographs One common point of detail is not sufficient, there must be several, spaced throughout the entire length of overlap After this adjustment has been completed, several points are pricked through the holes in the azimuth liner, and then a line is drawn with a chisel-edged pencil along a straightedge through these points on the photographs Before moving the photographs, these pencil lines should be checked by inspection to see that they pass through identical detail on both photographs If they are correct, the lines are then ruled in red permanent ink

The same general procedure is followed if a straightedge is used Because a straightedge is not transparent, it is much more difficult to be sure that its edge passes through identical detail on both photographs

Using this method with either an azimuth liner or a straightedge, azimuth lines can even be established accurately in cases where the overlap is insufficient to show the conjugate center or where a radial center is in the water After the azimuth lines have been inked they should be checked under the stereoscope

Azimuth lines can also be established direct by using azimuth liners with a stereoscope A pair of overlapping photographs is oriented under a stereoscope with the line between the two radial centers approximately parallel to the eyebase of the stereoscope One end of an azimuth liner is pinned down over the radial center of the left photograph, and while the stereoscopic model is being viewed, the liner is rotated around this center until the other end passes as nearly as possible through the conjugate center corresponding to the radial center of the right photograph This procedure is repeated on the right photograph with another azimuth liner The positions of the two azimuth liners are then meticulously adjusted until the full length of each etched line passes through identical detail in the model This azimuth line is then transferred to the two photographs Before the photographs are removed or disturbed, the azimuth line should be checked (See also 6244d)

This method is very convenient as both photographic images are viewed simultaneously Either method, however, is satisfactory where well-defined points of detail appear along the azimuth line and the work is done with accuracy If the photographs are to be used in a scale plot, the positions of the conjugate centers should be established at the same time

On photographs with considerable tilt or with tilt and relief, it may not be possible to adjust the photographs so that common points of detail lie along the etched line of the azimuth liner while it is held bisecting the radial centers In such cases an approximate azimuth line is drawn and an appropriate notation is made on the photographs

*4114 Horizontal Points on Photographs*

*Horizontal points* are used to fix the position and orientation of a photograph or a series of photographs with reference to known horizontal stations, in order that natural and artificial features imaged on the photographs may be represented on a plane surface in their true latitude and longitude

Each horizontal control point and each substitute point for horizontal control is indicated by a fine point pricked on the field photograph. Each point is surrounded by a triangle 30 mm on a side and is exactly identified by a fine ink leader terminating about 0.5 mm from the prick mark, with the station name lettered at its opposite end. (See fig 5 41.)

The accuracy of the identification of a horizontal point on an office photograph depends on the original accuracy of the field identification. Because an error in marking<sup>1</sup> a horizontal point on a photograph has the same effect as an error in plotting a horizontal station on a map manuscript, the field personnel spare no effort to attain the required accuracy of the field operations—that is, the making of points within 0.15 mm of their true positions. These field operations are referenced on field photographs and recorded on Form No M-2226-12, Control Station Identification. This form, or identification card, is completed for each horizontal station, referencing each station to a definite field photograph. The probable accuracy of identification and the necessary identification information, usually including a sketch, are included on each card. (See fig 4 2.)

Before horizontal points are marked on office photographs, all the information originating with the field personnel should be carefully studied. Any point whose identification is classified as doubtful (not positively identified within 0.15 mm of its true location) on an identification card and any additional points the photogrammetrist considers of doubtful identity shall be noted as such on the office photographs.

A horizontal point should be marked first on the clearest photograph on which it appears, or on the office photograph of the same number as the field photograph on which it was marked. With the use of a stereoscope this point may then be transferred to the other photographs in the descending order of their definition. The transferred points should always be checked against the information furnished on the identification card, using a magnifying glass or thread counter.

Each horizontal point shall be inked in washable ink on the office photographs in accordance with figure 5 41.

Substitute stations are often identified by the field personnel to serve in lieu of near-by horizontal stations. A substitute station is always a well-defined object which can be pricked direct on the photograph. This substitute point on the photograph is the photographic image of the substitute station. A substitute station is, in fact, a temporary horizontal station whose position has been determined from a measured distance and direction from the nearby horizontal station, which is not identified on the photographs. Because substitute stations can be accurately identified on photographs, they can often be held more rigidly during the assembly of the radial plot than can horizontal stations that are identified on the photographs by other methods.

The identification card for a substitute point (fig 4 2) includes a sketch showing the substitute station, the horizontal station, and the azimuth station. Information to plot or to compute its geographic position and any other pertinent detail that will aid in its direct identification on photographs are also included.

<sup>1</sup>In this manual the word *marking* when applied to control points is used as an inclusive term to include the steps—identification, pricking, and inking—that are used to locate a control point on a photograph.

### CONTROL STATION IDENTIFICATION

STATION BROWN, 1936 MAP NO T-8527  
 STATE Florida COUNTY Monroe PHOTO No C-5635(46)  
 IDENTIFIED BY BFL DATE 7-15-46 PROJECT No Ph-15(46)  
 ACCURACY OF IDENTIFICATION Positive  
 CHIEF OF PARTY J A Doe

REMARKS A = Fence corner  
B =  $\frac{1}{2}$  road intersection  
C = Lone bush  
D =  $\frac{1}{2}$  road normal to station  
Sta. to A = 37.3 m (122.4 ft)  
B = 41.1 m (134.8 ft)  
C = 28.0 m (91.9 ft)  
D = 28.8 m (94.5 ft) E = 28.3 m (92.9 ft)  
A to C = 62.2 m (204.1 ft)

INFORMATION REQUIRED FOR SUBSTITUTE STATION  
 INST STA. \_\_\_\_\_ AZ STA. \_\_\_\_\_  
 $\angle$  TO STATION \_\_\_\_\_ R DISTANCE { FT \_\_\_\_\_  
 \_\_\_\_\_ L DISTANCE { M \_\_\_\_\_

M 2226 12

SKETCH

### CONTROL STATION IDENTIFICATION

STATION MUD, 1930 MAP NO T-5971  
 STATE Florida COUNTY Monroe PHOTO No C 5782 (46)  
 IDENTIFIED BY BFL DATE 6-11-46 PROJECT No Ph-15(46)  
 ACCURACY OF IDENTIFICATION Positive  
 CHIEF OF PARTY J A Doe

REMARKS substitute station is the  
 $\frac{1}{2}$  of Road Intersection.

INFORMATION REQUIRED FOR SUBSTITUTE STATION  
 INST STA. MUD, 1930 AZ STA. MUD Az Mk  
 $\angle$  TO STATION 36°12'20" R DISTANCE { FT 211.3  
36°12'30" X DISTANCE { M 64.4

M 2226 12

SKETCH

FIGURE 4 2—Identification cards for a 'triangulation station and a substitute station

Any one of three methods is used to mark horizontal points on office photographs

(1) Using measurements from reference stations to the horizontal station

The information on the identification card of the horizontal station is used in marking a horizontal point on office photographs from reference measurements. This card includes a sketch of the horizontal station in relation to its identifiable reference stations, the ground measurements between the horizontal station and its reference stations, and the ground measurements between two reference stations. After the reference stations have been transferred from the field photograph to the office photograph and lettered to agree with the identification card, the local scale factor of the photograph is determined. The scales of the photographs in a project differ from one another, and the scale of any one photograph may vary considerably within its limits because of displacements, tilt, and distortion. These differences must be taken into account by determining the scale factor of the photograph at each horizontal point and applying this factor to the field measurements before they are used. The scale factor is determined by the following equation

$$\frac{\text{Photograph distance}}{\text{Ground distance}} = \text{Scale factor}$$

If the distance measured on the ground between two points of detail that can be unmistakably identified on a photograph is 71.3 meters and the corresponding distance measured on the photograph is 65.8 meters, the scale factor to be used in this part of the photograph is  $65.8 \div 71.3 = 0.92$

The reference measurements on the identification card are multiplied by the scale factor and the resulting values are used to swing arcs from the respective reference points. These arcs should intersect at a point which is the horizontal point. Where arcs do not intersect at a point, the distances should be checked. If no error is found, preference should be given to the shortest distances and to the arcs swung from the clearest and best-defined reference points.

Bow-spring dividers may be used to swing the arcs, if that part of the photograph is protected during the procedure with a temporary covering, such as cellulose tape, which is immediately removed after the horizontal point is pricked. (If cellulose tape is used, its adhesiveness should first be reduced by rubbing so that the tape can be removed without marring the surface of the photograph.) A bow-spring pencil may be used if the arc distances are checked with bow-spring dividers before the arcs are penciled.

(2) Marking direct

When the horizontal station is a natural or cultural object visible on the photograph it will be marked directly by the field party on the field photograph and the statement "marked direct" will be entered in the remarks column on the station identification card. The station is marked directly on the office photograph using a stereoscope and studying all information furnished by the field party, either on the field photograph or on the station identification card, so that no mistake will be made regarding the identity of the station.

The station identification card will include a plan-view sketch of the station and adjacent detail if there is any likelihood of the station being confused with some other nearby object. No sketch will be made on the station identification card if the station and adjacent cultural or physical details are quite clear on the photograph. Sketches are more often necessary for direct identification on photographs at scale 1:20,000 or smaller than on photographs at scale 1:10,000 or larger because more details are visible on the latter. Sketches are not made for stations on isolated prominent objects with no surrounding details, such as prominent objects in water areas.

Intersection stations on mountain peaks are an exception to the above. Such stations are ordinarily not visited. They are marked directly by the field party and each station identification card includes a profile sketch of the peak or a horizontal photograph of the peak to assist in the exact office identification of the point observed.

The ground position of an elevated horizontal point is marked on the office photographs if it is visible. Where the ground position is not marked, "(Elev)" should be inked alongside the point so that it will not be held during the delineation of the adjacent ground detail.

(3) Substitute stations

The substitute station is marked directly on the office photograph using a stereoscope and studying the sketch and data on the station identification card.

4115 *Pass Points on Photographs*

Pass points that can be marked direct with the same accuracy as horizontal points—that is, within 0.15 mm of their true location—are the only photogrammetric points necessary for the assembly of a main radial plot. Their positions are determined during a radial-plot assembly and are used in radial plotting for progressing from one photograph to another in line of flight and from one strip to another. These points are also used to control the photographs while detail points for use in map delineation are being located. Pass points are selected only for their value during the photogrammetric procedure of making maps and are not necessarily identifiable on the ground. For their distribution on photographs, see 422 (nine-lens photographs) and see 43 (single-lens photographs).

Each pass point must be carefully selected. Each point must be sharp and well-defined, with its image similar in size, shape, and definition on all overlapping photographs on which it is to be pricked. Images of low objects or structures that cast a negligible shadow are commonly selected. Each pass point is circled on office photographs in washable ink with a 6 mm circle (see fig. 5.42).

Typical images that can be used as pass points are grouped in the descending order of their preference of selection, however, there is little difference in preference of selection within each group.

## GROUP 1

(All images in this group must be unobscured by shadows, trees, etc. Intersection angles must be between 60° and 120°.)

- (a) Corners of cultivated fields of distinctive vegetation
- (b) Fence corners. It is generally a narrow strip of vegetation along the fence that makes the fence intersections sharp and well-defined (e.g. low-trimmed hedge corners)
- (c) A small bush in a clearing
- (d) Intersections of narrow and straight drainage ditches, such as mosquito control ditches, in marsh
- (e) Corners of wharves, piers, bulkheads, and sea walls
- (f) Paved airfield runway intersections and corners

## GROUP 2

(a) Road, lane, and trail intersections. Many of these intersecting at angles between 60° and 120° should be included in Group 1, however, as they are often obscured by shadows, trees, etc., and cannot then be exactly identified, they are generally classified in Group 2.

- (b) Beacons
- (c) Small alongshore rocks that are bare on all photographs used.
- (d) Intersections of sloughs in marsh
- (e) Intersections of wide or irregular drainage ditches
- (f) Intersections of ditches and natural drainage with roads, trails, and lanes

## GROUP 3

(a) Trees. To many who do not work with photographs, an isolated tree appears to make an excellent image because the dark spot stands out on the photograph and is readily identified. However, because the shadow of a tree and the image of the tree itself often blend, it is difficult for the photogrammetrist to pick out the actual trunk on all photographs. At times lone cedar and poplar trees are exceptions to this group and are classified in Group 2.

## GROUP 4

- (a) Bridges
- (b) Jetties. The inshore end of a jetty should be pricked if possible, as the offshore end is often obscured by breakers.
- (c) Buildings. Only small and low buildings are recommended, and these are only recommended when images in the other groups are not available.

4116 *Photo (-topo) Points and Photo-hydro Points*

Photo (-topo) points and photo-hydro points are defined and discussed in detail in section 46, Radial-plot Completion. Photo (-topo) points are located during the main radial plot because of the higher accuracy requirement (122), whereas photo-hydro points and detail points are usually left to be located during compilation. Photo (-topo) points may be substituted for pass points wherever they are properly situated for that purpose. Refer to 6244 for special points to be located by the main radial plot for manuscripts to be compiled on the Reading plotters, see also 461 and 5462.

4117 *Transfer of Points to Adjoining Photographs*

The transfer of horizontal points, pass points and photo (-topo) points to adjoining photographs must be accurate—that is, within 0.15 mm of the true location. The use of a stereoscope is necessary to attain this accuracy. The same methods are used as in pricking conjugate centers (4113). All pertinent information should be used to verify the identification and the transfer.

The identification and transfer of all points need not be checked by another photogrammetrist. The photogrammetrist who identifies the points, however, should have another photogrammetrist verify the transfer of any points, whose accuracy is doubtful (see 4251 and 4252).

## 412 DETERMINATION OF THE AVERAGE SCALE OF PHOTOGRAPHS

In mapping, the average scale of the vertical aerial photographs in a flight must be determined. This is particularly true where maps are compiled from photographs assembled by means of a radial plot. By constructing the projection to the average scale of the photographs, or by enlarging or reducing the photographs to a desired working scale, compilation and delineation of map manuscripts are facilitated.

Where a radial plot is assembled for each map, a different projection scale can be used for each manuscript, if necessary. Where a radial plot is assembled for several maps simultaneously, all maps involved in the plot must be at the same scale. The scale of photographs in the same flight is generally fairly uniform, but it may vary considerably between different flights—particularly when the flights have been made on different days.

Where a plotting unit involves two or more flights, the projections are made to the average scale of all flights if the average scale variation between flights is not more than 2 percent in areas of congested detail, as in harbor or city areas, and not more than 5 percent in open areas. Where there are large scale variations, the projections are often made to the scale of that flight from which will be delineated the largest area or the more congested area, considering at the same time the length of each flight involved and the variation in scale within each flight. If a ratio reflecting projector is available for use during delineation, the difficulties caused by scale variations are reduced and the same projection scale can be used over larger areas.

The average scale of the photographs in one flight or in a part of a flight is determined by assembling a preliminary plot for that specific purpose. (See fig 43.) A series of five or six photographs in a flight, with the first and last photographs fixed, or partly controlled, is satisfactory for such a scale plot. Where a partly controlled photograph is used, it should be controlled by more than one station so that several scale distances can be determined. After the radial centers, conjugate centers, and horizontal points have been marked on these photographs, a sufficient number of pass points must be added to bridge the distance between horizontal points. These pass points also indicate any badly



tilted photograph in the flight. Figure 4-8 shows a satisfactory distribution of pass points. These pass points should be selected so they form two irregular lines at approximately equal distances on each side of and parallel to the azimuth of the flight.

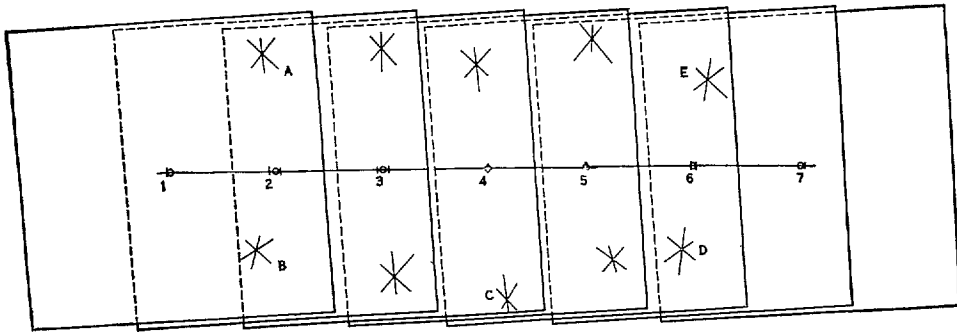

SCALE PLOT

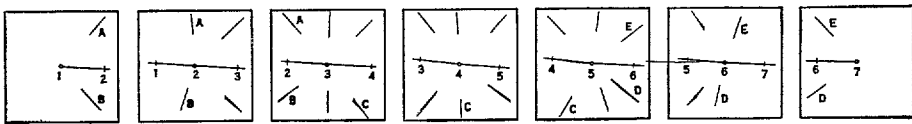

HAND TEMPLATES

FIGURE 4-3—Preliminary plot for determining average scale of photographs

For scale plots, a hand template is made of each photograph (see 4243). Radial centers and conjugate centers, radials through all horizontal points and pass points, and the azimuth lines are shown on the templates. (In figure 4-3 the conjugate centers are indicated by a tick instead of by the standard symbol.) Photograph numbers are placed by the radial and conjugate centers, and horizontal station names are placed alongside their radials.

After the templates have been made, the scale plot is assembled. The first template, or template No. 1, is taped to the plotting table after it has been oriented so that the extended flight will be within the table limits and will be conveniently placed. Template No. 2 is laid over template No. 1 so that their common azimuth lines are superposed. Template No. 2 is then moved along this azimuth to adjust the base length so that it will be an average of the distances between radial and conjugate centers as shown on the two templates.

Similarly, template No. 3 is laid so that its azimuth line is superposed on the corresponding azimuth line of template No. 2, and the base length adjusted so as to be an average of the base length as shown separately on templates No. 2 and No. 3. This procedure is continued until all the templates are laid—each base length on the template plot being an average of the two base distances shown on the two corresponding templates. This adjustment of base distances makes the scale of the plot approximately equal to the average scale of all the photographs. Due to this adjustment, there will be triangles of error at some of the horizontal points and pass points.

The scale plot is a graphic determination of the average scale of a strip of photographs, obtained by adjusting the distances between the radial centers and the conjugate centers. Obviously these distances are influenced not only by the flying height of the aerial camera but also by the tilt of the aerial camera and the elevation differences of the

objects of the images at the principal points. If there were no tilt and no elevation differences, each radial center and its one or two conjugate centers would be superposed in the plot almost exactly, the only discrepancy being that which is due to differences in flying height and that discrepancy is usually relatively very small. But tilt alone, or elevation differences alone, may cause these distances to be noticeably unequal. Hence, the procedure is one of averaging these various inequalities in an effort to obtain the best *average* condition throughout the strip. It is accordingly helpful to note such large relief differences discovered while preparing the photographs and any large tilt discovered while assembling the templates, so as not to allow the adjustment of the templates to be greatly influenced by irregular discrepancies.

The scale plot may also be assembled by tracing directly onto a transparent tracing medium (preferably plastic sheeting) the same information as was traced on each template. To do this, the first photograph is placed under the tracing and so oriented that the flight will not extend beyond the sheet. Then the radial center and all the conjugate centers, the radials to horizontal points and pass points, and the azimuth line are traced from this photograph onto the tracing. The next photograph is oriented under the tracing with its azimuth line coinciding with the azimuth line on the tracing from the first photograph. If the radial centers and conjugate centers on the photograph and the common centers shown on the tracing medium do not coincide, the azimuth line is held while any distance discrepancy is averaged between the centers. This procedure is continued for each succeeding photograph throughout the entire series that has been selected for scale determination. There will be triangles of error at some of the horizontal points and pass points. The most probable position of each control point is then marked in its triangle.

After the scale plot has been completed by either method, the distances between the horizontal points are inked and compared with the corresponding true distances to determine the scale of the plot—that is, the average scale of the photographs, according to the formula

Average scale of the photographs =  $\frac{\text{Scale plot distance } (a)}{\text{True distance } (b)}$  [(*a*) and (*b*) must be in the same unit of measure]

The scale plot distances may be measured with any convenient scale. They are measured generally in meters or millimeters where the true distances are given in meters.

True distances between many horizontal stations can be found in the lists of geographic positions published by the Coast and Geodetic Survey. Any distances that are not given may be computed with sufficient accuracy from plane right triangles using the differences in latitude and longitude of the two horizontal stations for the two sides of the triangle. The lengths of these sides are determined by multiplying the differences of latitude and longitude in minutes and seconds by the values in meters for 1 minute and 1 second of latitude and longitude taken at the middle latitude of the two stations involved. Their values are found in Special Publication No. 5, "The Polyconic Projection Tables." The plane distance is then found by taking the square root of the sum of the squares of these two sides, i. e., Plane distance =  $\sqrt{(\text{difference in latitude})^2 + (\text{difference in longitude})^2}$ . This method of determining plane distances is illustrated by the following example:

	Latitude	Longitude
Horizontal station C.....	28° 12' 59"994	82° 42' 50"103
Horizontal station B.....	28 03 57 774	82 34 25 560
	<hr style="width: 50%; margin: 0 auto;"/> 9' 02"220	<hr style="width: 50%; margin: 0 auto;"/> 8' 24"543
Middle latitude.....	28° 08' 28"884	

*Latitude computation*

$$\begin{aligned}
 1' &= 1846\ 95\ \text{m} \\
 1'' &= 30\ 783\ \text{m} \\
 1846\ 95\ \text{m} \times 9' &= 16622\ 55\ \text{m} \\
 30\ 783\ \text{m} \times 2''22 &= 68\ 34\ \text{m} \\
 \hline
 &16690\ 89\ \text{m}
 \end{aligned}$$

*Longitude computation*

$$\begin{aligned}
 1' &= 1637\ 3\ \text{m} \\
 1'' &= 27\ 288\ \text{m} \\
 1637\ 3\ \text{m} \times 8' &= 13098\ 4\ \text{m} \\
 27\ 288\ \text{m} \times 24''543 &= 669\ 73\ \text{m} \\
 \hline
 &13768\ 13\ \text{m}
 \end{aligned}$$

True distance =  $\sqrt{16691^2 + 13768^2}$  or 21636 m

The computation may also be made on Form M-2501-11—Approximate Azimuth and Distance Computation

Where the scale for a distance varies greatly from others within the same scale plot, it should be investigated for possible error. If no error is discovered and the average has been determined from only three photographs, that scale should be disregarded.

The average scale ratio of the photographs and the scale ratio selected for the projection or the grid will generally be an odd ratio, as, for example, 1/20,833. However, in drawing the projection and in plotting the ground control points, an even ratio scale will be used, as, for example, a 1/20,000 scale meter bar. Therefore each distance taken from the projection tables or the control computations must be multiplied by a scale factor before it is set on the even-ratio plotting scale. This scale factor is obtained from the formula

$$\begin{aligned}
 \text{Scale factor} &= \frac{\text{Projection scale ratio}}{\text{Plotting scale ratio}} \\
 \text{as, } \frac{1/20\ 833}{1/20,000} &= \frac{20,000}{20,833} = 0\ 960
 \end{aligned}$$

The scale factor is used much more than the average scale and generally is obtained directly without computing the average scale.

1 Scale plot distances are measured as ground distances by using an even ratio measuring scale, as, for example, a 1/20,000 meter bar

2 The scale factor then equals

$$\begin{aligned}
 &\frac{\text{Scale plot ground distance}}{\text{True ground distance}} \\
 \text{as, } \frac{28\ 445\ \text{meters}}{29,630\ \text{meters}} &= 0\ 960
 \end{aligned}$$

3 Average scale then equals 0.960 × the measuring scale ratio,

$$\text{as, } 0\ 960 \times \frac{1}{20,000} = \frac{1}{20,833}$$

TABLE 41—Scale factors

LINE	SCALE PLOT DISTANCE	TRUE DISTANCE	SCALE FACTOR
	<i>m</i>	<i>m</i>	
A to B	11,698	12,210	0.958
A to C	15,240	15,825	.963
A to D	24,790	25,876	.958
A to E	28,445	29,630	.960
B to C	20,710	21,636	.957
B to D	26,620	27,671	.962
B to E	26,125	27,072	.965
C to D	10,975	11,420	.961
C to E	18,695	19,596	.954
D to E	10,031	10,395	.965
Average scale factor -----			0.960
Average scale -----			$\frac{1}{20,833}$

Table 41 shows the scale factor for each line in figure 43. For convenience these horizontal points are named *A*, *B*, *C*, *D*, and *E*.

All the distances between pairs of horizontal points whose positions are derived from three or more photographs should be used for determining the average scale factor of this section of the radial plot. For example, each of the seven photographs (fig. 43) is used at least once in determining the distances *AC*, *AD*, *AE*, *BC*, *BD*, and *BE*. Five photographs are used for determining each of the distances *CD* and *CE*, while only three photographs are involved in determining each of the distances *AB* and *DE*.

Where published accurate large-scale maps or charts are available, "true distances" may be scaled from them with sufficient accuracy for use in determining the average scale factor of the photographs. Topographic features, such as road intersections, corners of docks, prominent offshore rocks, and islets whose positions have not changed between the date of the maps and the date of the new photographs are satisfactory for this purpose. To be certain that the best average scale factor is determined, several distances should be used and any scale factors that differ radically from the average should be disregarded.

#### 413 PROJECTION AND GRID CONSTRUCTION

Topographic features of the earth's surface are delineated on plane surfaces and are referred to projections or grids so that the features are represented with reference to each other as nearly as practicable as they are in nature.

The polyconic projection has been adopted by this Bureau for all original surveys. All topographic and planimetric maps and shoreline surveys shall be plotted and delineated on this projection, unless otherwise specified in the project instructions.

In this polyconic projection the central meridian is a straight line, all other meridians being curved. The parallels are represented by arcs of nonconcentric circles whose centers all lie in the extension of the central meridian and whose radii are determined by the length of the elements of cones that are tangent at the respective parallels.

This polyconic projection, its inherent accuracy, construction, etc., are treated in detail in the following publications: Special Publication No. 143, *Hydrographic Manual* (subject 732), Special Publication No. 5, *Tables for Polyconic Projection of Maps and Lengths of Terrestrial Arcs of Meridian and Parallels* (commonly known by its short title, "The Polyconic Projection Tables"), and Special Publication No. 68, *Elements of Map Projection*.

A grid is composed of two sets of equally spaced straight lines which intersect at right angles. A map grid is a grid drawn on a plane surface and used as a rectangular coordinate system for plotting positions and for scaling distances and directions in surveying and mapping. A map grid is not necessarily based on a map projection.

For each State of the United States, plane coordinate systems have been devised by the Coast and Geodetic Survey so that geodetic survey data can be used by methods involving only the formulas and computations used in plane surveying. The larger States had to be divided into two or more zones for each of which a separate grid was adopted to attain the desired accuracy. The criterion was that the geodetic (true) length and the grid length should nowhere differ by more than 1 part in 10,000—an accuracy quite adequate for most land surveys. Within the continental United States the grid or grids of the plane coordinate systems of the area involved shall be shown on all topographic, planimetric, and shoreline survey map manuscripts.

The Coast and Geodetic Survey computes and publishes the coordinates, on the appropriate State coordinate system, of all triangulation and traverse stations that have been adjusted on the North American Datum of 1927.

The State coordinate systems are described in the following publications: Serial No 624, Computation of Traverse by Plane Coordinates, Special Publication No 193, Manual of Plane Coordinate Computation, Special Publication No 194, Manual of Traverse Computation on the Lambert Grid, Special Publication No 195, Manual of Traverse Computation on the Transverse Mercator Grid, and Special Publication No 235, The State Coordinate Systems

In Alaska and other areas beyond the continental United States two grids are available (a) the Universal Transverse Mercator Grid which was developed by the Department of the Army and whose formulas and tables are published in Army Map Service Technical Manual No 7, Volumes I and II, and (b) a coordinate system based on projections for the World Aeronautical Charts as computed and published for the Department of the Air Force by the Coast and Geodetic Survey

Computations on the World Aeronautical Chart system are exactly comparable to the methods used for those State coordinate systems based on the Lambert Conformal Conic projection. The necessary constants may be obtained from World Aeronautical Charts Projection Tables, Aeronautical Chart Service, 1948, Volume II. Coordinates are derived by the following formulas:

$$y = R_b - R \cos \theta$$

$$x = X_0 + R \sin \theta \text{ (observe sign of } \theta \text{)}$$

$$\theta = l \text{ where } \Delta\lambda = \text{longitude from central meridian}$$

$$l = \text{Projection constant (from table)}$$

$$R_b = \text{Radius at latitude of arbitrary origin (from table)}$$

$$R = \text{Radius at latitude of point being computed (from table)}$$

$$X_0 = \text{value arbitrarily assigned to central meridian to avoid negative coordinates within radial-plot area}$$

#### 4131 *Projection and Grid Sheetings*

Several types of safety low-shrinkage plastic sheeting, matted or grained on one side, are suitable for map projections and grids. Cellulose acetate and vinylite are generally used by the Coast and Geodetic Survey. Either material can be procured in sheets 40 inches wide and 50 or 60 inches long or in rolls 40 inches wide and 50 or 100 feet long.

Base grids or base projections are drawn on vinylite sheeting about 0.009 inch thick. Vinylite has a relatively low coefficient of expansion and its freedom from distortion makes it a very suitable material for use in radial plots. It is not so suitable for map manuscripts, however, because of its brittleness. At low temperatures it will often crack or break, especially where its surface has been crinkled at any time.

Map projections and map grids are drawn on low-shrinkage acetate sheeting about 0.009 inch thick. This sheeting is not so stable in dimensions as vinylite, but it is less brittle.

Sheeting in rolls sets in this shape and acquires a curling tendency which is practically impossible to eliminate. Therefore, projections and grids should be constructed on sheets shipped flat by the manufacturer which have no such tendency to curl. When rolled sheeting has to be substituted it should be cut in sheets and laid flat to season for several days before use. All projections and grid sheets should be filed or stored flat.

Sheeting not in use should never be held down with weights of any kind, because changes in temperature and humidity will make the sheeting pucker or buckle around the weight.

All projections and grids furnished by the Washington Office are ruled on sheeting that has been properly seasoned and cared for prior to shipment.

*4132 Ruling Machine Projections and Grids*

The projection ruling machine at the Washington Office of the Coast and Geodetic Survey is a precision instrument on which accurate and uniform projections and grids can be constructed and checked in a fraction of the time required by hand methods. All projections and grids on plastic sheeting or similar distortionless mediums should be ruled on this machine, so far as practicable.

The maximum rectangular projection or grid that can be drawn on the machine is limited to  $38\frac{1}{2}$  by  $56\frac{1}{2}$  inches, although the size of the sheet may be 42 by 60 inches, and in special cases a projection can be ruled on a sheet size 46 by 65 inches. The above dimensions are for cases where the projection lines approximately parallel the sheet edges, where a skewed projection or grid is to be ruled, the distance between the diagonally opposite corners of the sheet must not exceed the above values when measured parallel to the projection lines.

Requests for machine-ruled projections or grids should be forwarded to the Washington Office at least 3 weeks prior to the desired delivery date. Each request must indicate the project number, the assigned map registry number, the scale, and the medium on which the projection or grid is desired. Where project layouts and registry numbers are not available in the Washington Office, a rough sketch must be furnished showing the sheet limits by latitude and longitude, the scale, and the orientation of the projection if it is not parallel with the sheet edges. A polyconic projection is always made unless some other projection is specified.

The polyconic projection is ruled in black permanent plastic ink. Grids of the State coordinate system, when ruled on a sheet with a polyconic projection, are ruled in colored permanent plastic ink, each grid represented is in a different color—the first, red, the second, green, and the third, purple.

All projections and grids ruled in the Washington Office are checked there, and the only additional check needed is between adjoining projections and grids. This check is very important and shall always be done. Each grid is plainly marked with the name of the State and zone or the local system if located outside the continental United States. The latitudes and longitudes of the projection and the coordinate values of each grid are also given. The date the projection was ruled and checked and the operator's initials are shown in the lower right-hand corner of each sheet.

*4133 Hand-Constructed Projections and Grids*

Base grids and projections constructed directly on the enameled surface of the plotting table obviously cannot be made on the projection ruling machine, but must be ruled by hand. The procedures of construction are described in the references listed in subject **413**.

The hand construction of a grid or a projection is facilitated and made more accurate by waxing small pieces of clear cellulose tape with a wax crayon (preferably black) and sticking the tape to the sheeting at the places where the measurements will fall. Each subsequent measurement made with a beam compass is then etched as a short arc through the wax. The intersections of the arcs in the wax are very sharp and clear. The waxed tape should not be removed until after the projection or grid has been checked.

Neither pens nor pencils should be used in a beam compass when making a projection.

All projection lines or grid lines should be penciled with a 2H or 3H pencil before inking.

*4134 Base Grids*

The sole function of a base grid is to provide a continuous grid for a radial plot involving several map manuscripts, particularly when the east-west dimension of the plot is considerable. The map manuscripts cannot be joined together for this purpose if the east-west extent of the plot is great because each is an individual polyconic projection. Any grid with the scale factor constant in all directions will serve the purpose. The various State grid zones are used for this purpose in the United States. In Alaska and other areas where there is no grid that approximates the conditions met by the State grid, either of two other systems may be used.

(1) The Universal Transverse Mercator Grid recently adopted by the Department of the Army, or

(2) The World Aeronautical Chart System computed by the Coast and Geodetic Survey for the Department of the Air Force

The Universal Transverse Mercator Grid can be computed with coordinates in meters from tables published by the Army Map Service. However, because of the large east-west extent of the grid zone, the angle between the geographic north and the grid north is in excess of the maximum tilt that can be set on the spline of the projection ruling machine, and it is therefore impossible to produce it on the machine.

Projection tables have been computed for the purpose of providing drafting coordinates for the construction of the standard Lambert Conformal Conic projection for the World Aeronautical Chart series. These tables are computed to ten decimal places and can be used to compute local independent plane coordinate systems at any latitude and with the central meridian at any conveniently selected longitude. By this means it is possible to compute plane coordinates of geographic intersections or geographic positions of plane coordinate intersections on a coordinate system selected with its central meridian near the center of a project and whose grid lines will not be excessively tilted with respect to the geographic meridian. (See 413.)

The main radial plot of a group of manuscripts should be assembled and adjusted on a base grid or grids. These base grids are on sheets used only for the radial plot. Map manuscripts on which detail is delineated are additional sheets. Base grids are preferred to base projections because, as previously explained, grids at the same scale can be accurately joined together in east-west and north-south directions, and because the same grid can be used over and over again in different parts of an area simply by changing the values of the  $Y$ - and  $X$ -coordinates (the distances which fix the position of a point on a grid). (It will be noted that the order of terms  $Y$ - and  $X$ -coordinates is used. This is done to keep the terms in the same order of usage as the terms which they represent—latitude and longitude.) Base grids should be constructed with such an accuracy that they will join without measurable error.

Base grids at standard scales may be constructed on the enameled surface of the plotting table. To construct such a grid, the straight central  $Y$ - or  $X$ -coordinate is drawn the entire length of the plotting table, using a 60-inch straightedge with a theodolite to give a line of sight or an extra long and rigid beam compass.

To construct the straight central  $Y$ - and  $X$ -coordinates with a beam compass, prick two points  $A$  and  $B$  the same distance from opposite edges of the table so that a line connecting the two will be approximately parallel to the table ends and approximately centered.

With the beam compass construct intersecting sets of arcs of equal radii from the points  $A$  and  $B$ . Construct sufficient intersections so that three or more points will be within the length of the straightedge used to draw the line. When drawing the line, overlap at least two intersection points as the straightedge is moved along to the next posi-

tion for continuing the line to its full length. Thus a straight line is constructed perpendicular to the line that would connect points *A* and *B*. It is well to prick each intersection with a fine needle point prior to drawing any part of the line. If the work is done with care, using sharp instruments and chisel-point pencils, the straightedge should bisect all the points.

To construct the straight line between points *A* and *B* select two of the intersecting arcs constructed to draw the first line and call these *C* and *D*. Intersecting arcs of equal radius should be constructed from these points. Points *A* and *B* and the intersection of the arcs constructed from *C* and *D* should fall in the straight line *AB*. This line is drawn similar to the line *CD* by having the straightedge bisect three or more points before drawing any section of the line. The grid can then be completed from these two perpendicular straight lines.

Base grids at standard scales of 1:10,000 or 1:20,000 are ruled with black permanent plastic ink, base grids at other scales are ruled with black nonpermanent plastic ink.

#### 4135 Map Projections

A map projection is the projection upon which the map is compiled. The polyconic projection is always used. A grid of the State coordinate systems is shown on the same sheet.

All map projections, if practicable, shall be ruled on the projection ruling machine. They shall be inked in black permanent plastic ink.

#### 4136 The Projection and the Grids on Map Manuscripts

On a map manuscript the projection intervals between meridians and parallels and the grid intervals to be shown depend on the scale and shall be according to the following table.

Table 42—Projection and grid line intervals

Scale of map manuscript	Projection line interval	Grid line interval (State coordinate system)
1:2,000 and larger	Every 5 seconds	500 feet
1:2,001 to 1:3,000	Every 10 seconds	1,000 feet
1:3,001 to 1:6,000	Every 15 seconds	2,000 feet
1:6,001 to 1:12,500	Every 30 seconds	5,000 feet
1:12,501 to 1:25,000	Every minute	10,000 feet
1:25,001 to 1:60,000	Every even minute	20,000 feet

Where fractions of minutes form the limits or junctions of a map manuscript, such as on 3¼- or 7½-minute map manuscripts, these fractional meridians and parallels shall always be drawn regardless of the scale.

Projection lines and grid ticks should be inked in 0.15 mm line widths in black permanent plastic ink.

After a map projection has been received from the Washington Office and the projection and the grid junctions with adjoining sheets have been checked, the grid intersections, the grid data, and the projection data are immediately inked. This should be done under



the supervision of either the supervisor of the radial-plot section or the supervisor of the stereoscopic mapping section, depending on which section will use the projection

The grid intersections for a State coordinate system are shown on each map manuscript by two ticks 1 cm long at right angles to each other, forming a cross at the point of intersection. The point where each grid line intersects the border meridians and parallels shall be marked by a tick 5 mm long from the border projection line outward. Ticks of the same coordinate value can be connected with straight lines to form the grid.

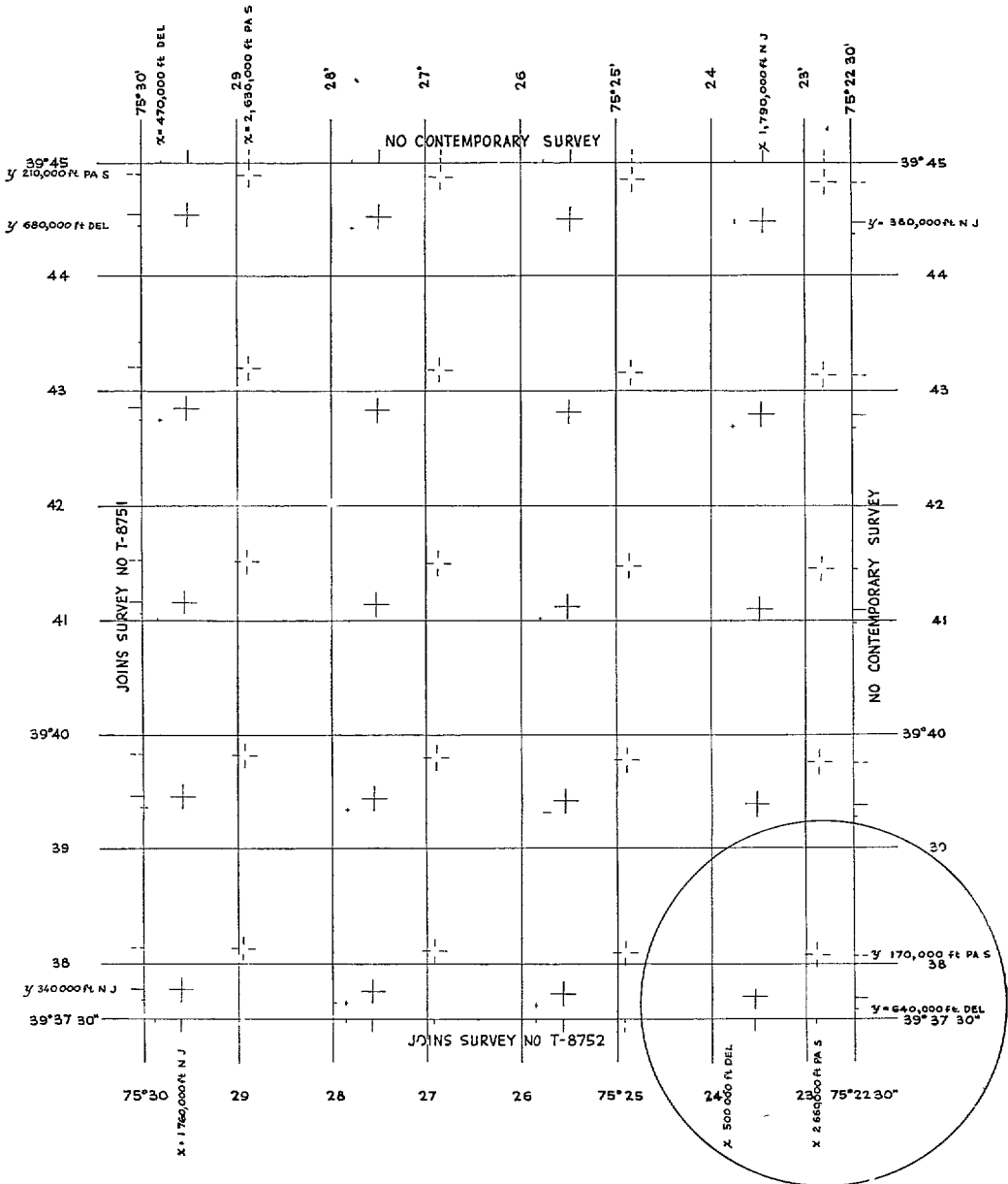

FIGURE 4 4a —The projection and the grids on a map manuscript†

On map manuscripts where there are overlapping grids of the State coordinate system, the ticks of each grid shall be indicated by different symbols in black permanent plastic ink—first, in solid lines, second, in short dashed lines, and third, in lines broken at the point of intersection (See fig 4 4)

The numbers representing grid and projection values shall be drawn in black permanent plastic ink in vertical figures with the projection digits 10-point and the grid digits 8-point in accordance with figure 4 4b (See 513.) Degree, minute, and second symbols must follow their respective numbers Degree symbols should be 1 0 mm in diameter, and minute and second symbols 1 0 mm long, all centered on line with the tops of the numbers Grid numbers (with no zeros omitted) and the name of the State and zone are shown at diagonally opposite corners on the manuscript, where only one grid is shown the numbers and designations shall be placed in the southwest and northeast corners Where two or more grids are shown the numbers and designations of the principal grid shall be placed in the southwest and northeast corners and the numbers and designations of the other grids shall be placed in the southeast and northwest corners (See figures 4 4a and 4 4b)

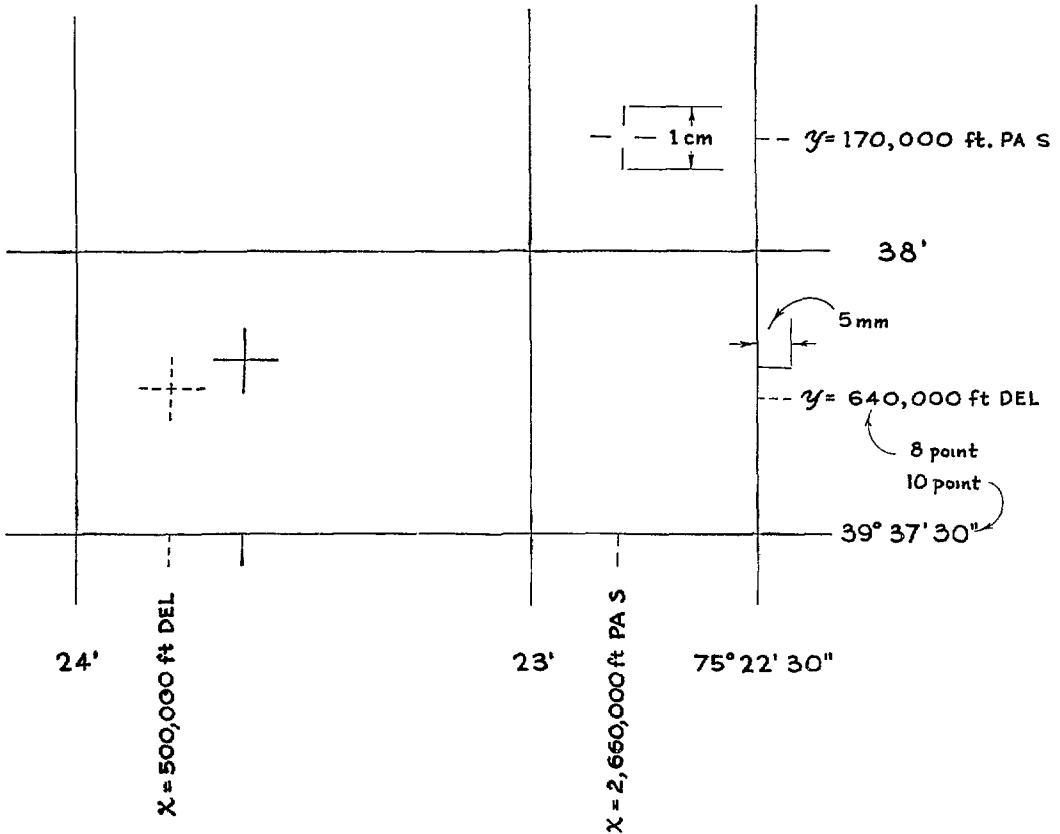

FIGURE 4 4b—Full size detail of the projection and the grids on a map manuscript

Regardless of the projection line interval or the scale, the degrees of latitude and longitude shall be shown at the border parallels and meridians For scales of 1 25 000 and larger they shall be repeated where the minutes are multiples of 5, and for scales



The geographic position data of triangulation stations and traverse stations are furnished on Form 28B, Geographic Positions. For each station the latitude and longitude in degrees, minutes, and seconds are given, as well as the distances and azimuths to adjacent observed stations. The seconds of latitude and longitude are also often given in meters and these are known as the *dms* (meridional differences) and *dps* (parallel differences), respectively, of the station. Thus, if station QUARRY is in latitude  $26^{\circ} 19' 02''392$  N (73.6 meters), longitude  $80^{\circ} 05' 30''382$  W (842.7 meters), its *dm* is 73.6 meters north of the 19-minute parallel, and its *dp* is 842.7 meters west of the 5-minute meridian.

Seconds can be converted into meters simply by multiplying them by the respective meter values of 1 second of the meridional or the parallel arc at the latitude of the station. To determine the *dm* and *dp* of station QUARRY, its latitude in degrees and minutes is found in Special Publication No. 5, "The Polyconic Projection Tables", and by interpolation the meter length of 1 second of meridional arc at latitude  $26^{\circ} 19' 02''392$  is found to be 30.775 meters. This value is multiplied by the number of seconds of latitude north of the 19-minute parallel, as

$$30.775 \text{ m} \times 02''392 = 73.6 \text{ m (} dm \text{)}$$

The distances in meters that the station is south of the nearest minute parallel and east of the nearest minute meridian are called "back distances", or the back *dm* and back *dp*. They are computed for use as a check in plotting, and to detect any error in the projection graticule or any distortion in the sheet.

The seconds of latitude north of the 19-minute parallel are subtracted from 60 (number of seconds in a minute), and multiplied by the meter value of 1 second to give the back distance, as

$$30.775 \text{ m} \times 57''608 = 1772.9 \text{ m (back } dm \text{)}$$

Similarly by interpolation the value of 1 second of parallel arc at latitude  $26^{\circ} 19' 02''392$  is 27.733 meters. This value is multiplied by the number of seconds of longitude west of the 5-minute meridian, as

$$27.733 \text{ m} \times 30''382 = 842.7 \text{ m (} dp \text{)}$$

The seconds of longitude west of the 5-minute meridian are subtracted from 60 (number of seconds in a minute), and multiplied by the meter value of 1 second to give the back distance, as

$$27.733 \text{ m} \times 29''618 = 821.4 \text{ m (back } dp \text{)}$$

Some triangulation stations that are identified to control photographs have not yet been adjusted on the North American Datum of 1927—the available geographic positions are on the North American Datum. The booklet, "Datum Differences", has been published by this Bureau so that stations on the North American Datum can be converted to the North American Datum of 1927. In this booklet the datum differences are given in both meters and seconds.

To convert the geographic position of a station from the North American Datum to the North American Datum of 1927, convert the seconds of arc into meters and then apply the datum correction with the correct algebraic sign as given in the tables in "Datum Differences".

Topographic stations whose geographic positions are known and which are to be used for radial-plot control shall also be listed on Form M-2388-12, Control Station Data. Their *dms* and *dps* are practically always given, but these should be corrected for datum and scale where necessary.

#### 4142 Data for Plotting by Coordinates

The plane coordinate positions on the State coordinate systems of Coast and Geodetic Survey stations, and of other stations whose positions are on file, are published on Form 709, Plane Coordinates. All plane coordinate positions published by this Bureau are on the North American Datum of 1927. The *Y*- and *X*-coordinates are given in feet and hundredths of feet for each station, with an azimuth to at least one other station. The State, projection, and zone are also given.

The origin of each State coordinate system is placed so that all coordinate values are positive. *Y*-coordinates increase progressively northward, *X*-coordinates increase progressively eastward. For various map scales there is a required grid interval (see table 4.2).

The coordinates need be entered on Form M-2388-12, Control Station Data, only when they are to be used in plotting a station, then they are entered similarly to *dms* and *dps*. For example, for map grid intervals of 10,000 feet the parts of the coordinates which exceed the nearest multiple of 10,000 are the forward differences, to be plotted north and east of the appropriate grid lines, and total coordinate values subtracted from the next higher multiple of 10,000 are the back differences to be plotted south and west of the appropriate grid lines. The coordinate differences must be corrected for any scale factor and then plotted directly in feet.

#### 4143 Data for Plotting Substitute Stations

Where substitute stations have been identified by the field party and referenced to control stations by a measured distance and an angle, the position of the substitute station may be plotted directly using this measured distance and angle, provided the projection or grid is not so distorted that its position cannot be plotted within 0.15 mm of its true location.

Form M-2226-12 contains the following data which are needed to plot substitute stations:

- (a) Name of control station (instrument station)
- (b) Name of azimuth station (initial)
- (c) Angle to substitute station measured to the right or left of azimuth station (initial)
- (d) Distance in meters (and in feet)

In using azimuths, the observed angle between the azimuth station (initial) and the substitute station can be added to or subtracted from the azimuth of the initial line (control station to azimuth station) to obtain the azimuth to the substitute station, for example,

Azimuth from control station to azimuth station (initial) -----	230° 10' 30"
Angle left from azimuth station -----	25 33
Azimuth from control station to substitute station -----	204° 37' 30"

Angles measured to the right of the azimuth station (initial) are added to the azimuth of the initial line, and angles measured to the left of the azimuth station (initial) are subtracted from the azimuth of the initial line.

Where the azimuth from the control station to the azimuth station (initial) is not known but the position of the initial station can be plotted on the sheet, the measured angle can be plotted without computation. Where the initial station cannot be plotted on the sheet, the necessary azimuth may be computed on Form M-2501-11—Approximate Azimuth and Distance Computation—in lieu of the more exact computation on Form 662, Inverse Position Computation, or on Form 662a, Inverse Position Computation (by calculating machine).

The distance measurement is multiplied by the scale factor of the map on which it is to be plotted, the distance in feet is converted to meters as a check.

Substitute stations referenced by a measured distance and a sun azimuth should be plotted in the same manner. Observations of the sun for azimuth are recorded on Form 266, Observations of Sun for Azimuth and Time, and they are computed on Form 269, Computation of Azimuth and Longitude, or on Form 269b, Computation of Azimuth and Longitude (by calculating machine).

Where a substitute station is referenced to a control station by a traverse involving two or more angle stations its geographic position or plane coordinates shall be computed and shall be tabulated on Form M-2388-12, Control Station Data.

All computations to determine the positions of substitute stations shall be checked prior to plotting. These computations are to be filed in the data folder of the map within whose limits the positions plot.

#### 4144 *Data from Adjoining Photogrammetric Surveys*

Many radial plots adjoin other radial plots or prior photogrammetric surveys. Each may be adequately controlled within itself according to specific control requirements, and in many cases each may use the same horizontal stations along a common junction area. In addition, previously located pass points and photo points are used to ensure a satisfactory junction of the topographic features.

### 415 PLOTTING CONTROL STATIONS ON MAP MANUSCRIPTS

There are several classes of horizontal control stations that are plotted on map manuscripts. The position of each plotted station is identified on a map manuscript by its appropriate symbol, name, and date (see fig. 541) which are inked in black permanent plastic ink. The actual pricked point is identified with a black wax crayon or ink (see 4151).

Horizontal control stations plotted on map manuscripts are divided, according to the method of location and the accuracy of position determination, into the following classes:

(a) The first class consists of control stations of third-order accuracy or better that are located by triangulation, traverse, or three-point fixes. The positions of all such stations that are to be shown within the limits of each map are to be plotted by *dms* and *dps* (see 4151) or coordinates (see 4153) and shown on the map manuscripts, whether or not they all are to be used to control the photographs. "Lost" stations are to be omitted.

Each such station shall be symbolized by an equilateral triangle (45 mm on each side) symmetrically placed around the pricked point, with the base of the triangle normal to the meridian and the apex pointing north.

(b) The second class consists of substitute stations used for photogrammetric control. Only those substitute stations that are to be used to control the photographs shall be plotted on the map manuscript before the radial plot is assembled.

Substitute stations located by one angle and a distance may be plotted by measuring the distance along an azimuth line determined by plotting the angle with a metal protractor, or by using its computed

latitude and longitude or plane coordinates. The positions of those stations located by two or more angles and measured distances shall be computed by latitude and longitude or by plane coordinates and then plotted (see 4151 and 4153).

Each such station shall be symbolized as illustrated in fig 541. Substitute station names are not inked on the map manuscript unless misidentification is possible.

(c) The third class consists of topographic, three-point fix, and photo stations, and pass points. Any of these that are used to control the photographs and are of the required accuracy shall be plotted on the map manuscript.

This class will generally be plotted by transfer, they will be plotted by *dms* and *dps* or coordinates only where this is necessary. They shall be symbolized as illustrated in fig 542.

All control stations must be plotted with the greatest accuracy, because any inaccuracies in their positions may result in errors in the radial plot. Each control station should be plotted within 0.15 mm of its correct position. Before the positions are pricked with a fine needle, this accuracy shall be checked.

In plotting positions bow-spring dividers of appropriate size and beam compasses in good mechanical shape with sharp and even points should be used, the scales and metal protractors must be accurate and should be tested before use.

Arcs should be scribed through an area of black wax crayon on clear cellulose tape in order not to mar or scratch the surface of the map manuscript (see 4133 and fig. 46). The tape is removed after the plotting of the station has been checked.

#### 4151 Plotting by Dms and Dps

The most accurate method of plotting control points is by *dms* and *dps* or by coordinates with a beam compass and/or dividers as described. This method is used where the ultimate in accuracy is needed.

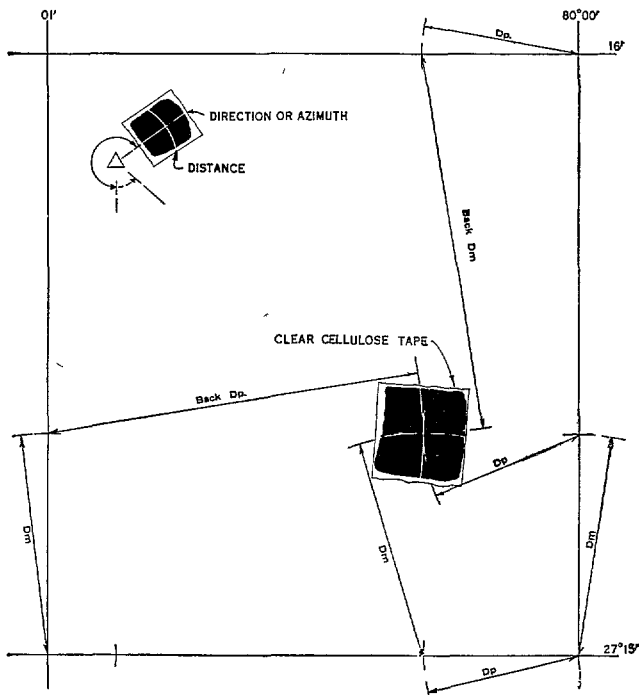

FIGURE 46—Plotting by *dms* and *dps*

To plot the geographic position of a control point on a map manuscript, the projection quadrilateral within which the control point falls is first identified, and then the point is plotted, as in figure 4 6, from the information on Form M-2388-12, Control Station Data.

The  $dm$  is set on a recommended instrument (see 415) and plotted twice, northward from the south parallel of the quadrilateral, once from a point adjacent to but not at the east meridian intersection, and again from a point adjacent to but not at the west meridian intersection. This distance is lightly etched as an arc across the east meridian and the west meridian. With a second instrument the  $dp$  is similarly plotted twice from points on the east meridian slightly offset from the parallel and meridian intersections. This  $dp$  distance is lightly etched as an arc across the north and south parallels of the quadrilateral.

A piece of clear cellulose tape marked with black wax crayon is placed at the approximate position of the control point within the quadrilateral. From the intersection of the etched arcs with the south parallel and east meridian, arcs of the  $dm$  and  $dp$ , respectively, are scribed through the area of wax crayon. Then similarly, arcs of the back  $dm$  and back  $dp$  are swung and scribed from the north parallel and west meridian.

Where the projection is accurate and without distortion within the quadrilateral, the scribed arcs intersect in a fine point. Where there is distortion, a small quadrilateral of error is formed by the scribed arcs. The position of the point should be proportioned within this small quadrilateral of error.

If the projection has expanded or contracted, the dimensions of the quadrilateral should be measured and the  $dms$  and  $dps$  adjusted for scale error before plotting them. The scribed arcs will then intersect in a fine point, eliminating the quadrilateral of error.

After the plotting has been checked and the point pricked, the cellulose tape may be removed.

For illustration purposes in figure 4 6 long arcs are shown crossing the parallels and meridians. Actually, in practice, short fine etched lines crossing the parallels and meridians should mark the  $dms$  and  $dps$ .

For projections ruled on the projection ruling machine any point on a projection line is as correct as the intersections of the parallels and meridians.

#### *4152 Plotting with Latitude and Longitude Scales*

Latitude and longitude scales are designed particularly for use at scales of 1 10,000 or 1 20,000 for plotting or scaling geographic positions by seconds without having to convert the seconds into meters. They are also recommended for use in checking plotted points. These scales are used diagonally across the projection lines and plotting is performed by a proportional process in which any distortion in the manuscript is automatically compensated for. An experienced operator can use these scales somewhat faster than the beam compass or dividers, but the principal economy in time occurs when distortion in the manuscript would make an adjustment of the values in meters necessary when plotting with a meter bar.

Points should be plotted adjacent to the edge of the scale by pricking a small hole in the manuscript with a fine needle point. Best results are obtained by tilting the needle slightly away from the edge of the scale, so that the needle point and the scale divisions are not obscured by the shaft of the needle.

For scaling seconds of latitude of a plotted position, place the scale diagonally across the projection so that the latitude edge bisects the station point, and the 0- and 60-second marks at the ends of the scale coincide with the lower and upper minute lines of latitude. The value in seconds is read directly from the scale. A similar procedure is followed for



seconds of longitude, except that the edge bearing the longitude scale corresponding to the latitude of the locality must be used and the ends of the scale, of course, made to coincide with the lines of longitude

To plot a position it is necessary to plot the correct latitude twice near the meridians east and west of the station and, laying a straightedge bisecting the two points to etch a line along the straightedge through black wax crayon on clear cellulose tape placed in the approximate position of the station

The value in seconds of longitude is then plotted twice near the adjacent parallels and a line is etched along the straightedge bisecting the two points. The correct position is at the intersection of these two lines. Instead of plotting two points for longitude, the scale may be placed diagonally across the sheet so that the ends of the scale coincide with the minutes of longitude and so adjusted that the scale crosses the latitude line at the correct position for pricking the longitude directly on this line

#### 4153 *Plotting by Coordinates*

To plot a control point by coordinates, the grid square within which the point falls is first identified. The coordinates of the southwest corner of a square identify it. If control point WAGON has the coordinate values of  $Y = 723,263.65$  and  $X = 802,993.35$ , at the scale of 1:20,000 the coordinates of the southwest corner of the square in which the point falls are  $Y = 720,000$  and  $X = 800,000$ . From these grid lines the  $Y$ - and  $X$ -grid differences are plotted

A control point is plotted by coordinates in the same way one is plotted by *dms* and *dps*. (See 4151.)

The  $Y$ -grid difference (3,263.65) of WAGON is plotted north from points on  $Y$ -grid line 720,000 slightly offset from the grid line intersections. This distance is lightly etched as an arc across the  $X$ -grid lines 800,000 and 810,000. The  $X$ -grid difference (2,993.35) is plotted east from points on  $X$ -grid line 800,000 slightly offset from the grid line intersections. This distance is lightly etched as an arc across the  $Y$ -grid lines 720,000 and 730,000. From the intersection of the etched arcs with the grid lines, the forward and back  $Y$ - and  $X$ -distances are etched through an area of black wax crayon on a small piece of clear cellulose tape. Control point WAGON is pricked at the intersection of these arcs after its position has been checked

#### 4154 *Plotting by Azimuth or Angle and Distance*

When plotting azimuths (geodetic or grid) or angles, a metal protractor should be used whose accuracy has been verified on a test plate furnished for that purpose (see 4533 in Special Publication No. 143, Hydrographic Manual). Geodetic azimuths published as part of the geographic position data are always reckoned clockwise from the south through  $360^\circ$

To plot a point by angle and distance, not only the point at which the angle was measured but also the station used as an initial must be within the limits of the map manuscript, or the azimuth between the two must be plotted from the station at which the angle was measured. The transparent center piece of the protractor is accurately centered over the point at which the angle was measured. The fixed arm of the protractor is rotated until it passes through the initial point, and either the right or left movable arm (according to the direction the angle was measured as shown on Form M-2226-12) is set at the desired angle. The direction to the new point can then be etched with a pricker along the fiducial

edge of the arm, making a fine line through the black wax crayon previously placed on the clear cellulose tape on the map manuscript at the approximate position of the point. Before the line is etched, the position of the protractor should be checked to see that it is properly centered over the point at which the angle was measured and that the fixed arm passes through the initial point. The measured distance is then etched as an arc crossing the direction line, using a bow-spring divider or a beam compass.

To plot a control point by a geodetic azimuth and distance, the azimuth is plotted clockwise from the south, referred to a north-south line established for that purpose through the point of origin.

To plot a grid azimuth and distance, the procedure is similar except that a grid is used instead of a projection.

The plotted positions of these points should be checked before the points are pricked.

#### *4155 Plotting by Transfer*

Where graphic control sheets are available at the same scale as a map manuscript, the points on the control sheet that are to be used in controlling photographs or that are to be shown on the map manuscript shall be plotted by transfer.

The method of transfer described in **416** is used. The map manuscript is superposed on the control sheet with the corresponding projection or grid lines in coincidence. The points are transferred by pricking them on the map manuscript and then marking them with the appropriate symbol.

Where the projection or grid lines on the two sheets will not coincide because of distortion, and the difference is too large to be accurately taken care of by this method or where the sheets are at different scales, the points should be scaled and replotted, using a scale factor determined between the two sheets.

### **416 PLOTTING CONTROL ON BASE GRIDS OR BASE PROJECTIONS**

All control points used to control the radial plot may be plotted on the base grids or base projections by transferring them from the map manuscripts. Whenever possible, base grids shall be used instead of base projections (see **4134**).

Map and base grids for the same area are constructed at the same scale, usually with no measurable differences between the two large enough to be evidenced square by square, however, a map grid should be immediately checked against its base grid so that work will not be done where the differences are larger than the plotting accuracy requirements allow.

If a base grid constructed on a plotting table is used, the table should be cleaned and the new grid values for the radial-plot area should be assigned and inked.

If base grids ruled on vinylite sheeting are to be used, a sufficient number of sheets should be assembled to ensure that the radial-plot area is amply covered. The grid line junctions should be perfect—at least one straight line should be superposed on a *Y*- or *X*-grid line (depending on the sheet assembly) of each adjoining base grid. The grid lines across the junctions should be checked with a long straightedge. Grid values for the radial-plot area shall be assigned and inked on each sheet.

A map manuscript is superposed on its base grid with the corresponding grid lines in coincidence. If all the grid lines are in coincidence, the map manuscript is fastened in place. Then the control points are pricked with a sharp pricker vertically through their positions on the map manuscripts into the base grid. After all the control points have been systematically pricked square by square, approximately half of the map manuscript can

be unfastened. Then that part of the map manuscript can be rolled back and forth while each pricked hole in the base grid is accurately identified and inked. The points on the other half of the map manuscript are later similarly identified and inked.

If all the grid lines are not coincident, the map manuscript should be adjusted on the base grid so that individual corresponding squares are held coincident while their control points are pricked. It is doubtful that further adjustments will be necessary, however, if they are necessary, the squares should be accurately subdivided and superposed section by section as the points are pricked.

In inking control points on base grids, each point should be encircled and the pricked point clearly identified with black wax crayon or ink. Triangulation points should be distinguished by triangles, and substitute points by squares, around the circles. The name of each point should be lettered and points of doubtful accuracy indicated. See also 6244 for special requirements for base grids for use with the Reading Plotter.

Before a map manuscript is superposed on its base grid, all operations involved in the construction of each should have been checked. The transfer of the control points through to the base grid and their marking should be checked before the map manuscript is unfastened and removed. Where the grids are not identical, this checking must be done section by section as the transfer was done and obviously with the map manuscript unfastened.

A record of the checking shall be made and filed in the map folder for each map.

## 42 RADIAL-PLOT ASSEMBLY OF NINE-LENS PHOTOGRAPHS WITH HAND TEMPLETS

The hand-templet method is used entirely in the radial-plot assembly of nine-lens photographs.

Because certain characteristics are inherent in nine-lens photographs, special procedures must be followed in assembling radial plots in order to ensure results that will meet the accuracy required by the Coast and Geodetic Survey and the National Standards of Map Accuracy.

### 421 DISPLACEMENTS AND DISTORTIONS ON PHOTOGRAPHS AFFECTING THE ASSEMBLY OF RADIAL PLOTS

Displacements and distortions of images affecting the accuracy of radial directions of vertical nine-lens photographs are as follows: tilt, relief and scale, and transformer displacements and paper distortions. These displacements and distortions must be dealt with before the assembly of a radial plot.

Displacements and distortions caused by aberrations in the optical elements and those caused by the adjustments of the optical systems are too small to affect the accuracy of radial directions of office nine-lens photographs.

#### 4211 *Correction for Effect of Tilt*

The most vivid indications of the presence of tilt in aerial photographs are apparent during the assembly of a radial plot of transparent templets in the form of relative image displacements. The presence of tilt may sometimes be detected from the photograph index or from the radial plot by the offset of a single photograph center from the general course of a continuous flight line or by an increase (or decrease) in the distance between photograph centers followed by a corresponding decrease (or increase). Tilt can some-

times be detected during the preparation of the photographs for radial plotting by the fact that common azimuth lines of an overlapping pair of photographs do not pass through the corresponding images. This discrepancy, however, may also be created by the transformer displacements discussed in 4213.

Where the photograph scale is near the radial-plot scale and where the relief differences in the area are small, a tilt of  $2^\circ$  can generally be tolerated without seriously affecting the radial plot. (A method of determining the approximate amount of tilt is explained in chapter 3.) The following table shows other combinations of tilt with relief and scale which may be tolerated.

TABLE 43—*Tolerable combinations of tilt with relief and scale*

Tilt	Relief and scale (combination which can be tolerated) in percent of flying height	
	Radial center	
	Principal point	Midpoint
<i>Degrees</i>	<i>Percent</i>	<i>Percent</i>
1 -----	10	25
1½ -----	5½	20
2 -----	3	15
3 -----	0	7

If the combination of elements is more severe than indicated for use of the principal point and thereby great enough to affect radial directions severely, the templet should be redrawn using the midpoint (4212) as the radial center.

The criterion used in determining the values in table 43 is an assumed maximum tolerance of 0.3 mm lateral error in any radial direction.

#### 4212 Relief and Tilt Displacements

On truly vertical photographs radial directions are not changed because of relief displacements. These directions radiate from the nadir point, which in this case is also the principal point.

Where tilt and relief displacements are both present, there is no one origin from which all radial directions are correct, but a point (called the midpoint) approximately halfway between the nadir point and isocenter is used as the origin of radials. The positions of the nadir point and isocenter relative to the tilt are shown in chapter 3, and in that chapter is demonstrated a method for the determination of tilt by an analysis of tilt displacements. This method should be followed by photogrammetrists until they have become familiar with tilt displacements.

It has been noted that, after the photogrammetrist has followed this method a few times, he may make the allowances for relief and scale displacement mentally without any computation and thus derive a very logical value for the tilt displacement (or the tilt angle itself). This is especially true where images at sea level can be used. The accompanying graph (fig. 47) may then be consulted for the distance from the midpoint to the principal point. An error of 1 or 2 mm in the distance has little or no appreciable effect. The direction of the midpoint from the principal point is toward the images which show maximum outward displacement because of tilt.

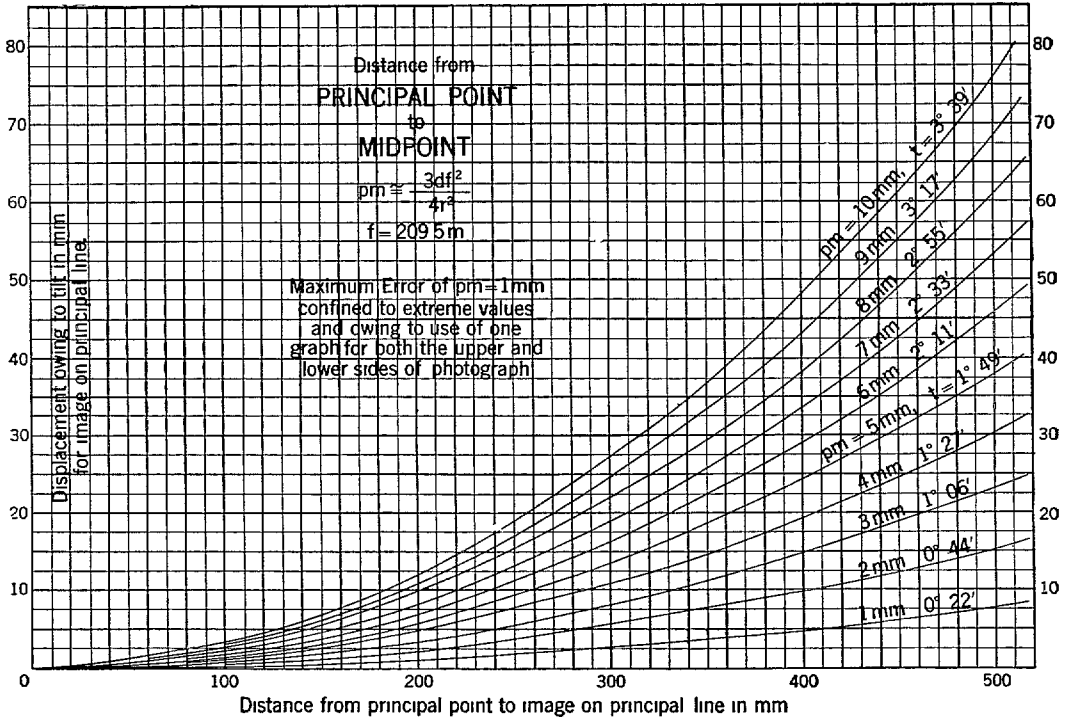

FIGURE 47—Graph for determining the distance from the principal point to the midpoint

4213 Paper Distortions and Transformer Displacements

Radial directions on nine-lens photographs are subject to errors due to paper distortion and transformation

Ordinarily paper distortions are greater across the gram of the paper than with the grain. This differential distortion is generally not greater than 3.0 mm and rarely greater than 4.5 mm along the neat limits of one side of a photograph.

In transforming a photograph, all negative distortions may not be adequately corrected because film distortions can amount to as much as 0.2 mm in radial direction and are difficult to detect. If they are detectable they are indicated by the failure of details to match along the wing junction lines, however, small differences in match along these lines do not necessarily indicate distortions in radial direction.

These distortions and displacements shall in all cases be analyzed and corrected as necessary when making the templates for radial plotting. The analysis and correction can be made readily by use of a calibration photograph and/or transparent templet furnished by the Washington Office (see 4242).

Nine-lens photographs taken since September 1945 have white fiducial marks in the four corners of each wing chamber and in the corners of the central octagon. The principal point also appears as a small white cross at the center of the photograph. The fiducial marks are exposed on the film in the aerial camera at the moment the aerial photograph is exposed.

Certain variations may occur during the transforming procedure which may change the appearance of the photograph or the positions of the fiducial marks relative to one another. These variations do not necessarily lower the value of the photograph in making a radial plot. In spite of the variations, the fiducial marks continue to be not only indicators of

discrepancies but also a means for correcting those discrepancies (see 4242). Some of the variations are enumerated and discussed as follows

(a) As the nine chambers of a single photograph are printed one at a time on different portions of the same sheet of photographic paper, the fiducial marks on any print as compared to the calibration print are likely to have slightly different positions in the different chamber margins. However, because the fiducial marks are on the film itself, they have a fixed relation to photographic detail in the same chamber

(b) The fiducial marks of each chamber and those of adjacent chambers do not join to form symmetrical figures (this is due to the accumulations of many small errors)

(c) The outer fiducial marks on any print, as compared to the calibration print, may be different distances from the principal point. This is true from chamber to chamber as well as from photograph to photograph

(d) The boundary lines between the chambers are due to the photographic masks used in the transformer printer and have no necessary relation to the fiducial marks or to the photographic detail. However, the relation of the positions of the chamber boundary lines relative to the fiducial marks usually remains fairly constant because of the mechanical construction of the printer

#### 422 PASS POINTS ON NINE-LENS PHOTOGRAPHS

In assembling a radial plot, only a few pass points (4115) should be pricked on the photographs. A reasonably regular pattern of points is desirable, a rigid pattern cannot be adhered to because of the variable forward and side laps of the photographs and the configuration of the land. Usually, however, when all requirements for the selection of points have been fulfilled, there will be a pass point every 6 or 8 inches. Azimuth lines, cross azimuths, and the approximate positions of the conjugate centers on these azimuths should be transferred to each photograph to aid the photogrammetrist in determining the spacing and the distribution of these points

With nine-lens photographs it is desirable to have at least one or two pass points in each chamber—preferably not too near the wing junction lines. These points are used to control each chamber so that additional photogrammetric points can be accurately located during compilation (see 46). For a check on the position of a pass point, at least three radials must intersect in a point to form a strong intersection. It is frequently essential and desirable that the intersection be formed by four or five radials, to add certainty to the intersection, to extend the radial plot, and to contribute to the accuracy of the plot as a whole.

Nine-lens photographs generally are taken with a considerable forward lap (66 to 80 percent) and side lap (60 percent). This results in an excessive number of radials that can be used in locating pass points. Therefore, in radial plotting nine-lens photographs, an effort should be made to avoid unnecessary radials in order to reduce the time and labor involved in marking the points on the photographs. Generally, radials from photographs beyond the adjacent flight strips and radials from photographs in line of flight but beyond the adjacent photographs are unnecessary and may be omitted. However, this statement is not intended to preclude the use of radials from distant photographs where they will strengthen the location of a particular point.

To eliminate these unnecessary radials systematically, a concentric circle should be inked around the principal point on each photograph, and only those pass points that fall within or tangent to this circle should be pricked. (This circle in no way affects the pricking of horizontal points.) The supervisor-in-charge of the radial-plot section should determine the size of this circle. Generally a circle 38 cm in radius is satisfactory. If the overlap is less than is generally required, a circle with a radius of 44 cm should be used, which only eliminates the corners. Where the overlap is greater, the size of the circle should be reduced to eliminate radials from photographs beyond adjacent flight strips.

4221 *Pass Points on Single Flights*

For a single flight of nine-lens photographs six pass points should be selected for each photograph—three on each side of the radial center and approximately on a line normal to the flight line at that point. After the pass points have been transferred to overlapping photographs the pattern of pass points on each photograph should resemble figure 48. Because of water areas the pass points cannot always be selected to conform to this pattern, however, the symmetry of the pass points on opposite sides of the flight line should be as close as practicable. Points should not be selected closer than 2 inches from an azimuth line.

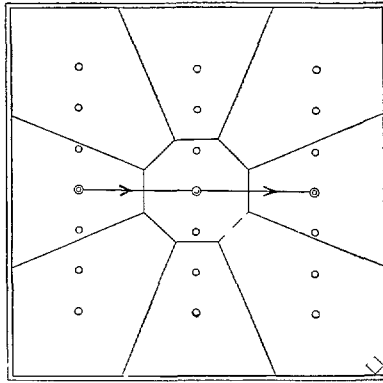

FIGURE 48—The distribution of pass points for the radial plot assembly of a single flight strip of nine lens photographs

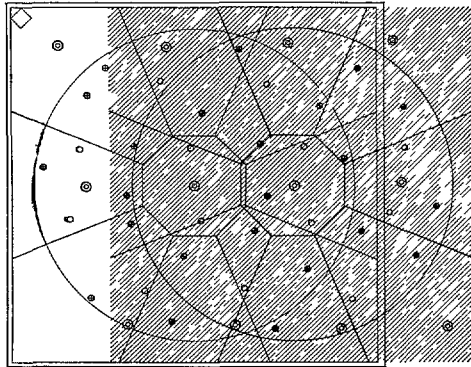

FIGURE 49—The distribution of pass points on two nine lens photographs in a flight strip for an areal plot

4222 *Pass Points for an Areal Plot*

No definite pattern can be followed for pricking pass points on nine-lens photographs for an areal plot. The stagger of photographs on adjacent flights, the irregular flight lines, and the irregular spacing of the photographs make this impossible. However, approximately fifteen pass points should be pricked on each photograph. These should be distributed somewhat evenly within the inked circle on each photograph.

If all the conjugate centers are approximately located before the pass points are pricked, a more adequate distribution can be made. Two points should be pricked within the center chamber of each photograph—one on each side of the flight azimuth and near a

line which might be drawn at right angles to the azimuth line at the radial center. All chambers on each photograph should be controlled, therefore, additional points should be pricked wherever they are necessary.

Figure 49 shows the distribution of pass points on two nine-lens photographs in a flight strip for an areal plot. The photographs for this area have a forward lap of 67 to 75 percent and a side lap of 55 to 60 percent. The additional pass points necessary to control each chamber are indicated by encircled X's.

#### 423 AZIMUTH LINES ON NINE-LENS PHOTOGRAPHS

Azimuth lines are ordinarily plotted on nine-lens photographs as stated in 4113 but occasionally substitute centers are used in lieu of those methods. These substitute centers are solely for plotting the azimuth lines and are not used as the origin of other radials, they are selected as follows:

(a) Prick an identifiable point in the direction of the azimuth line to the conjugate center concerned (See fig. 410). If this is done, relief displacement will be in the direction of the azimuth and will not affect its accuracy.

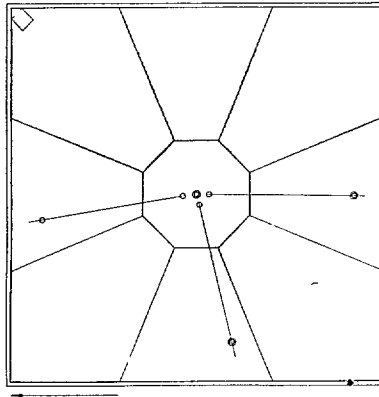

FIGURE 410—Carrying azimuths forward with substitute centers pricked in the direction of the azimuths

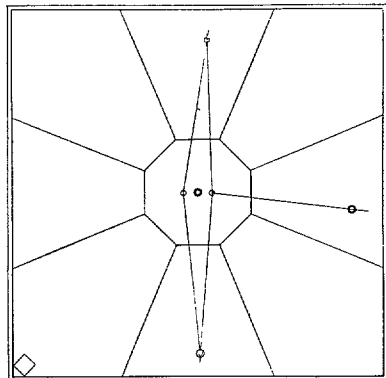

FIGURE 411—Carrying azimuths forward with substitute centers normal to the azimuths

(b) If an identifiable point is not available on the azimuth line, prick two points—one on each side of the principal point (normal to the azimuth concerned) and equally spaced from the principal point (See fig. 411). The azimuth lines are then drawn to both points, and appreciable displacement errors can be balanced out. This latitude is allowable because these points are not used as radial centers during the radial-plot assembly with hand templates.



## 424 HAND TEMPLATES FOR NINE-LENS PHOTOGRAPHS

*4241 Transparent Sheets for Templates*

Flat transparent vinylite sheets are recommended for making templates for nine-lens radial plots. Because of the rigid accuracy requirements for the assembly of radial plots, this plastic is particularly desirable owing to its characteristic of low differential shrinkage even in large sheets.

Thin vinylite sheets (about 0.005 inch thick) are almost free of any distortion for 2 years under ordinary varying conditions of room temperature and humidity. The objection to the brittleness of vinylite can be disregarded because templates are not continually handled and folded.

Vinylite sheets polished on both sides should be purchased in 36- by 36- by 0.005-inch standard size sheets. Whenever cellulose acetate sheets of a clear low-shrinkage type are to be used, they should be purchased in the same dimensions. Plastic templet material should never be ordered in rolls.

*4242 Preparation of Plotting Templates from a Calibration Photograph*

A calibration photograph is taken over the Ohio Calibration Area after each overhaul of the nine-lens camera, and again just prior to the next overhaul of the camera. The calibration area contains many control stations and the transformed prints of calibration photographs are made to agree with the plotted positions of the control stations by adjustments of the transforming printer. The residual errors of the calibration prints are within the limits of control identification and graphic plotting—usually within 0.1 mm.

The fiducial marks on all photographs taken prior to a new overhaul should have the same positions relative to one another as on the calibration photograph. Where this is not the case, distortions are still indicated and their discrepancies are corrected by means of the fiducial marks.

Metal-mounted calibration prints and/or calibration templates (figure 4.12) will be furnished each photogrammetric office and shall be used in the preparation of templates for radial plotting. The series of photographs to which each calibration print and/or templet applies will be stated in the transmitting letter or in a separate letter.

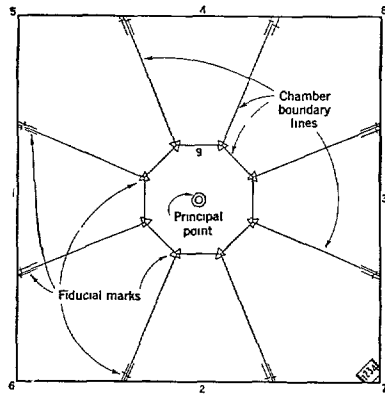

FIGURE 4.12—Calibration templet

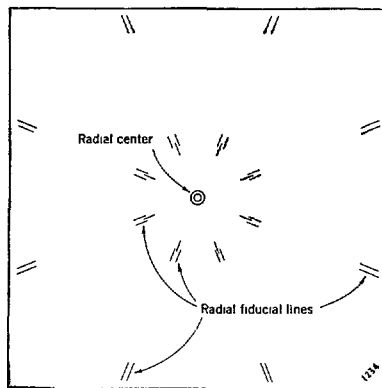

FIGURE 4 13 —Plotting templet

If not already furnished, a calibration templet of transparent vinylite shall be carefully traced from the calibration photograph showing all the fiducial marks, the principal point, the chamber boundaries, and the numbered corner. Each photograph to be used in a radial plot shall be inspected for discrepancies by superposing the calibration templet on it. Discrepancies between the positions of the fiducial marks on the templet and those on any other photograph are indicators of errors due to either the transforming procedure or paper shrinkage, or both.

The fiducial marks shall be utilized wherever the discrepancies are large enough to affect the accuracy of the radial plot seriously. Before the plotting templet has any lines drawn on it, it shall be superposed on either the calibration photograph or the calibration templet. Radial lines shall then be carefully traced onto the plotting templet through the fiducial marks. (See fig 4 13.) They may be traced in a colored ink to differentiate them from the other radial lines.

Instead of tracing radials on the plotting templet, as discussed in the preceding paragraph, each plotting templet, in turn, may be taped to the calibration templet and the cross marking the principal point of the calibration templet transferred onto the plotting templet. The pair of templates may then be used for correcting radials as stated in 4243.

#### 4243 Orientation and Adjustment of Plotting Templates

The radial fiducial lines on the plotting templates may be utilized in either of two ways:

(a) Center the plotting templet on a photograph and, working one chamber at a time, orient the templet so that a fiducial line coincides with the corresponding fiducial mark on the photograph. Draw radials through all photogrammetric points that are on or near the same direction as the fiducial mark and also in the same chamber. For drawing radials to other points in the same chamber, rotate the templet slightly so as to subdivide the total angular error proportionally between its two fiducial marks. For drawing radials to points in another chamber, first rotate the templet so as to make the corresponding fiducial marks of that chamber coincide. Use only the fiducial marks of the chamber which contains the photogrammetric detail, adjusting separately for each chamber.

(b) A somewhat more rapid and practicable method may also be used. Center and orient the templet as before. If the two outer fiducial marks of a chamber do not coincide simultaneously, decenter the templet radially to or from that chamber until the two pairs of marks do coincide. Draw all the radials for points in that chamber. Readjust similarly for the next chamber, using only the fiducial marks of the chamber being traced.

Transforming errors in the center chamber are indicated by the fiducial marks in the corners of that chamber. A simple rotation of the center chamber is the most probable

error This can be corrected for with one setting of the plotting templet, which is rotated the amount indicated by the displacement of the parts or segments of the center chamber fiducial marks

Almost all paper prints (other than metal-mounted) are distorted sufficiently to require radial corrections The described methods correct for paper distortions as well as for transforming errors

It is not practicable to make all the nine-lens photographs for radial plotting as accurately as the calibration prints are made For this reason, many of the prints for radial plotting will contain small transforming errors However, these need not affect the radial plots as the methods described here and in 4242 provide the means for eliminating them

All unusual difficulties shall be noted in the Descriptive Report and shall also be reported to the Washington Office by letter This includes abnormally large photograph discrepancies and the failure of templets to fit plotted control stations after all precautions have been taken If there is sufficient time, a reprinting may be requested unless the original print bears a note explaining that the unusual condition cannot be corrected

#### *4244 Inking Photographic Information on Templets*

After a templet has been oriented on a photograph, the photographic information is inked in black nonpermanent ink on the templet (see 512 regarding inks for this purpose)

Radials should be inked as fine as possible—certainly not wider than 0.15 mm They must be straight, must bisect the points indicated on the photograph, and must radiate from the radial center of the photograph Any radial that does not meet these requirements should immediately be removed and re-inked Because of the templet adjustments that are necessarily made to correct transformer displacements and paper distortions (4243), a check should be made of those adjustments by a photogrammetrist other than the one who inked the photographic information on the templets

Radials to photogrammetric and horizontal points should be approximately 8 cm in length, balanced on both sides of the point Horizontal points, with the exception of topographic points and hydrographic points, should be indicated by a triangle at the end of each radial At least one radial should be named Each topographic or photogrammetric point used for control should be indicated by a circle

Azimuth lines and cross azimuths are inked from the radial center 3 to 5 cm beyond the conjugate centers The proper photograph number should appear in at least one place on each azimuth line

Any notations made on the photograph indicating the doubtful identification of a point or azimuth line shall also be noted on the templet

Each templet should be numbered in one corner (corresponding with the photograph) and also near the radial center

Radial-plotting templets to be used in connection with the Reading Plotter require a somewhat different treatment as stated in chapter 6

#### **425 ASSEMBLING THE RADIAL PLOT WITH HAND TEMPLETS**

In assembling a radial plot, the hand templets are oriented by means of horizontal points on the base grid (see 416) to form graphic triangulation Adjustments necessary to eliminate any error of closure on ground control are made during the actual assembly of

the templates by adjusting the individual templates and by checking all discrepancies for mistakes and blunders

The orientation of a template with three or more control points by means of horizontal points is a graphic solution of the three-point problem. The theory of the three-point problem is analyzed in **3252** of this manual and more completely in subject 333 in Special Publication No 143, Hydrographic Manual

In assembling a radial plot, the templates are laid in the order of their strength—beginning with those templates that contain the largest number of well-distributed positively identified horizontal points, thence using templates having strong three-point fixes, and eventually using templates having weak three-point fixes and little or no control. Photogrammetrists who have not assembled a radial plot with hand templates may have difficulty in selecting the most strongly fixed templates. The orientation of these templates affects the orientation of adjoining templates whose azimuth lines are held or adjusted to them.

The following several types of three-point fixes are listed in the order of their strength

(1) The strongest fix is where the radial center is centered inside an equilateral triangle formed by three horizontal points and where these points are as near the outer limits of the photograph as clarity of photographic detail will allow accurate identification. The shape of the triangle may vary and the fix still be strong if no angle at the radial center is less than approximately  $60^\circ$ —the nearer the angles equal one another the stronger will be the fix. The accuracy of the orientation of the template diminishes as any one point approaches the radial center.

(2) When a template has horizontal points on only half of it, the relative positions of the three horizontal points and the radial center determine the strength of the fix. Weak or indeterminate fixes must be avoided. When the radial center plots in an arc and does not appreciably disturb the relation of the radials to the horizontal points on the base grid, the fix is weak, conversely, when a slight movement of the radial center moves the radials away from one or more of the horizontal points, the fix is strong.

The fix is stronger the nearer the sum of the two angles of the radials to the horizontal points approaches  $180^\circ$  and the nearer the angles equal each other. Neither of the angles should be less than  $45^\circ$ . The points should also be far enough away from the radial center so that radials to pass points at the delineation limits of the photograph are correct in radial direction when the template is oriented.

Whenever more than three points are available they should all be used to check the position and the orientation of a template.

Not all radial plots can be started from three-point fixes, although such fixes will be more frequent when nine-lens photographs are used (see **159**). It is entirely practicable to lay a radial plot between horizontal points without the benefit of three-point fixes. This is discussed in section **43**.

#### *4251 Horizontal Points Not Held During the Radial-Plot Assembly*

It is highly improbable that horizontal points of third-order or higher accuracy contain inaccuracies which can be detected by radial-plot methods, unless blunders have been made in the observations, computations, or identification. Of course, where the records definitely indicate an error in position sufficiently large to be plottable at the scale of the map manuscript, the position must be corrected before plotting on the base grid or manuscript, or that horizontal point must be ignored. Horizontal points of third-order accuracy or better established by other bureaus or agencies that are suspected of error shall be treated in the same manner as those established by the Coast and Geodetic Survey.

All horizontal points identified "positive" by the field party shall be used in radial-plot assemblies, unless there is a plethora of such points and the project instructions authorize

that some may be withheld and used in checking the accuracy of completed maps. If the preliminary procedures are within the required accuracies, it should be possible to hold all these points during a radial-plot assembly. Where some horizontal points cannot be held, every effort should be made to isolate the trouble. If misidentification is suspected at certain control stations, the field party shall be requested to furnish new identification for those stations. Similarly, if an error in the location of a substitute station or other error in the control survey is suspected, the field party shall be requested to make the necessary resurvey to furnish an accurate location. If it can be assumed that a station, or group of stations, has been correctly identified, including the measurements for the substitute stations, etc., and it is suspected that the geographic positions (determined by another field party prior to the present photogrammetric field party) are in error, all the facts shall be reported immediately to the Washington Office so that the condition can be investigated before the radial plot is completed. Any such points and the facts concerning them should be noted in detail in the Descriptive Report and on the identification card for each station involved.

Where horizontal points identified "doubtful" by the field personnel cannot be held and are not necessary to control a radial plot, they should be ignored. That a "doubtful" point was not held should be noted on the appropriate identification card.

Ideally, a completed radial plot should hold all the positively identified horizontal points exactly, common azimuth lines should exactly coincide, and the directions to photogrammetric points should intersect in points. This ideal is rarely attained completely in practice because of small inherent errors in the photographs which cannot be exactly corrected and because of small human errors. Thus, the photogrammetrist must use judgment in adjusting the templates. All accurately located and positively identified control should generally be held exactly even though this causes slight triangles of error at the photogrammetric points and slight lack of coincidence along azimuth lines. However, in some cases, the plot is improved by shading some of the control points—that is, by permitting some of the radials to miss their horizontal points by small amounts (0.1 to 0.2 mm).

With spider or slotted templates slight errors are averaged out automatically by mechanical adjustments.

#### *4252 Preliminary Radial-Plot Assembly*

Radial plots vary considerably and the procedures in laying them need not be exactly the same in every case. However, a preliminary assembly of the templates of a radial plot is usually made prior to the main radial plot. This preliminary plot is made solely to isolate errors in field and office work which are then corrected prior to laying the main radial plot. During the assembly of this preliminary plot, most of the errors, omissions, and difficulties can be isolated and corrected. Following the preliminary plot, the main radial plot is laid, as discussed in 4253.

The preliminary plot is assembled without reference to a projection or grid. The plot is started with any two templates, usually two near the center of the area. These two templates are assembled by holding the common azimuth line and assuming the length of the base which fixes the scale of the plot. The plot is then developed outward from these first two templates by holding the azimuth lines and resecting all points located with the templates already laid. Under ideal conditions, all azimuth lines will coincide and all directions to photogrammetric points will intersect in points. Departures from the ideal

indicate errors which may be corrected before laying the main radial plot. Even with this preliminary plot it is usually necessary to lay the main radial plot twice. (See 4253.)

Common errors made in preparing photographs and templets, and procedures to be followed in finding and correcting these errors are as follows:

(a) Errors affecting horizontal points

- (1) Incorrect relation of a State grid to a projection on a map manuscript
- (2) Incorrect marking of horizontal points
- (3) Incorrect conversion of seconds of a geographic position to meters
- (4) Incorrect grid differences due to ruling
- (5) Incorrect datum correction or datum correction not applied to the horizontal point values
- (6) Incorrect scale factor or scale factor not applied to the horizontal point values
- (7) Incorrect plotting of horizontal points
- (8) Incorrect transfer of horizontal points to the base grid
- (9) Incorrect assembly of base grid

The marking of horizontal points on office photographs should be checked against the identification cards and the field inspection photographs.

A complete check should be made of the computations on the control data forms.

A check should be made of the plotting of horizontal points on the map manuscripts and their transfer to the base grid.

The relation of the State grid to the projection on the map manuscripts should be checked.

(b) Incorrect plotting of azimuth lines and cross azimuths. The transfer of the azimuth lines and conjugate centers should be checked.

(c) Photogrammetric points incorrectly identified or omitted on overlapping photographs. Each photograph should be checked.

(d) Errors affecting templets

- (1) Incorrect construction
- (2) Templet distortions

The templets should be checked against the calibration templet and against the photograph.

(e) Errors caused by tilt

When common azimuth lines are superposed, it is possible that a horizontal or photogrammetric point cannot be accurately intersected when all other horizontal or photogrammetric points are accurately intersected. An error, such as one of those listed in (a) and (c), may be the cause.

If the horizontal points and photogrammetric points cannot be held when common azimuth lines are superposed but can be held by slipping from the azimuth, the error is possibly caused by the incorrect plotting of azimuth lines.

The photograph is probably tilted if common azimuths are held and the radials on a templet cannot be made to intersect horizontal points, photogrammetric points, and cross azimuths on both sides of the flight line, if the scale of the templet appears to be larger on one side than on the other, and if the azimuths do not cut identical detail.

#### *4253 Final Radial-Plot Assembly*

It is usually necessary to lay the main radial plot at least twice. The first lay-down will serve to isolate errors not found by the preliminary plot, discussed in 4252, and will serve to shorten the time interval required for the final main radial plot. It is necessary that the final main radial plot be laid quickly and positions of photogrammetric points and photograph centers transferred immediately to the map manuscripts because of possible changes in dimensions of the material, due to varying temperature and humidity. In the

first lay-down notes should be made of the order of laying templets, so that the same order may be followed when the final plot is assembled. If practicable, the same employee should assemble the preliminary plot and both the main radial plots.

To assemble the main radial plot, the templets are laid on the base grid beginning with those with the strongest fixes (see 425). Working between two fixed templets on the best controlled flight strip, the partly controlled adjoining photographs are laid and then the intermediate templets are laid. Each templet is accurately oriented by superposing common azimuth lines and by meticulously adjusting the templets so that the radials bisect the horizontal points and pass point intersections formed by previously laid templets. Any remaining discrepancies or omissions on a templet are immediately corrected and then the templet is re-laid. After a templet is accurately oriented it is smoothed and secured with Scotch masking or cellulose tape. Wherever possible, photographs that are difficult to orient because of apparent large tilt displacements should be omitted in the assembly of the radial plot. Where they are necessary, their tilt should be computed (if sufficient data are available) and a new templet should be made.

The final radial plot is assembled in the same manner. With the knowledge that the templets and base grid are complete and correct and with other information learned from the first plot, each templet is laid with extreme precision and considerable speed. Because the method of securing templets with tape is not perfect, all final radial plots should be assembled and the control points transferred to the map manuscripts in the same day. Rather than assemble a plot over two days, an extended day should be planned. Templets needing slight adjustments for a more precise orientation are discovered when adjacent templets are being laid and are adjusted before these adjacent templets are finally laid.

A few radials that do not hold to the ground control or intersect at photogrammetric points may remain even in the final radial plot assembly. These radials and the station points that determine them must be corrected, or specifically marked, or removed from the office photographs during the final radial plot assembly so that they will not cause erroneous orientation of the photographs in the subsequent location of photogrammetric points as described in 463. Occasionally a photograph is not used in the final radial plot assembly because of excessive tilt, such a photograph must be specifically marked so that it will not be used, or will be used with caution, for the subsequent location of photogrammetric points.

Figure 4 14 shows the final radial-plot assembly for a map manuscript comprising land and water areas. The pass points and radial centers are ready to be transferred to the map manuscript.

#### *4254 Transfer of Pass Points and Radial Centers*

When the radial-plot assembly is complete or a sufficient portion can be worked on without interfering with the completion of the assembly, positions of the pass points and radial centers determined by the assembly should be transferred to the map manuscripts.

Because of the thickness of the templets, care must be taken to avoid errors caused by parallax. Each pass point whose position is determined by three or more radials intersecting in a point should have this point of intersection pricked with a fine needle on the top templet. The photogrammetrist pricking these points should observe and prick each point from a vertical position and then identify it with a concentrically inked circle.

After the pass points and radial centers have been marked on the top templets, each map manuscript should be superposed on the templet assembly with its grid lines registered over the corresponding base grid lines. If there are no distortional or scale differences in

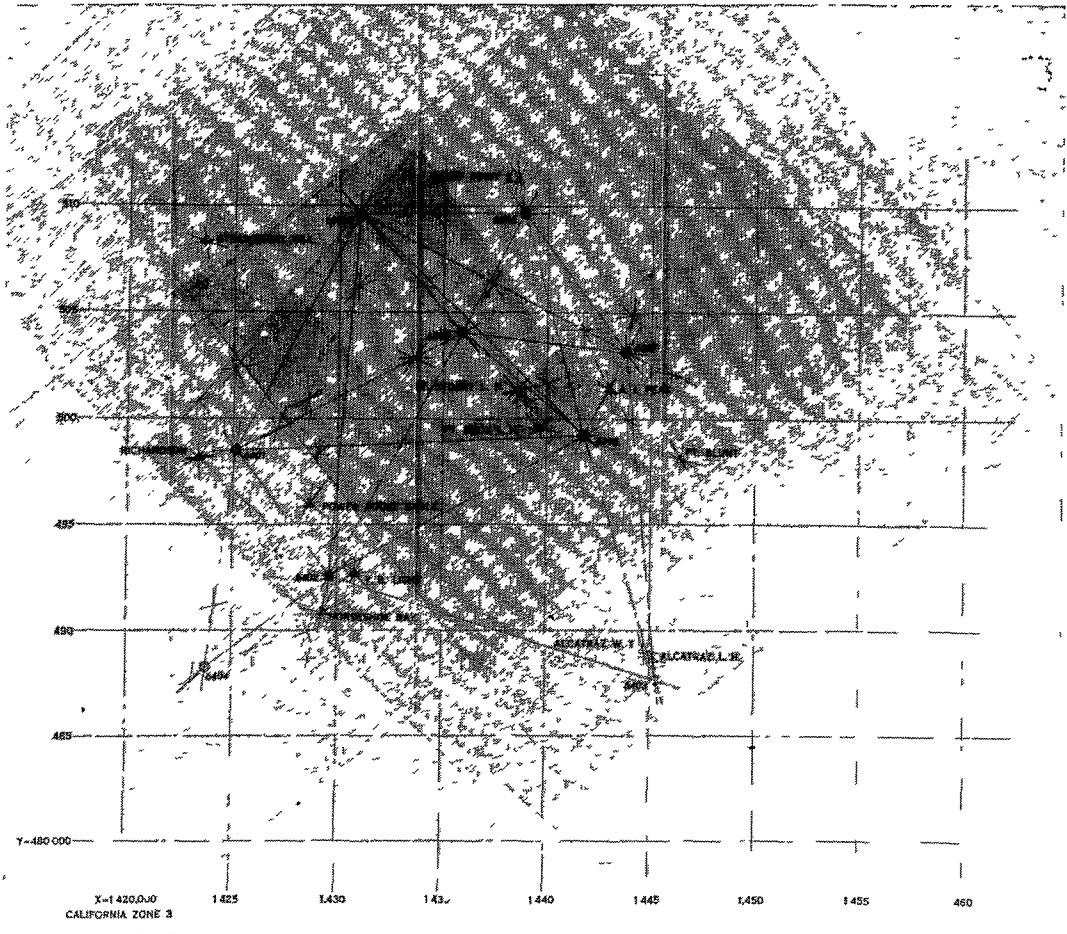

FIGURE 4 14 —Final radial plot assembly for a map manuscript

the sheetings, the grid lines and horizontal points on the base grid and map manuscript should be in coincidence. Then the pass points and radial centers within the limits of the map should be pricked on the map manuscript and identified by freehand penciled circles. When all the pass points and radial centers have been transferred, the map manuscript is removed and the pricked points are inked on the back in accordance with figure 5 42. If there are distortional or scale differences, the same method of transfer should be followed as is described in 416.

Many photogrammetrists prefer to prick the grid intersections and to ink some grid lines on the top templates to aid in obtaining a more accurate register between the map manuscript and base grid.

After the pass points and radial centers have been transferred and checked on each map manuscript, those beyond the map limits of each map manuscript are transferred to it from adjoining map manuscripts. This assures that each pass point or radial center is transferred from the radial plot only once. Thus, two or more positions for the same point will never be pricked.



Figure 4 15 shows a map manuscript with the positions of the pass points and the radial centers transferred from the radial-plot assembly in figure 4 14 This map manuscript is now ready for the location of detail points

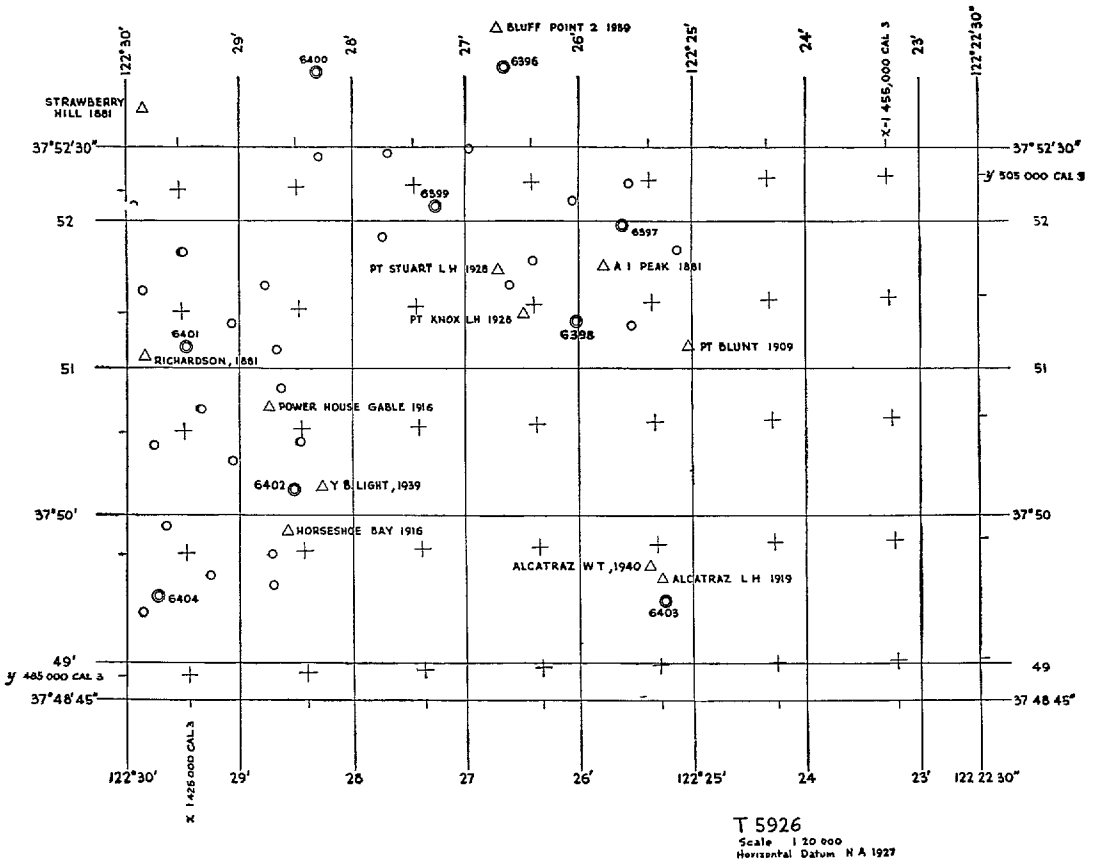

FIGURE 4 15—Map manuscript with pass points and radial centers

To make rectified nine-lens prints for use on the Reading Plotter the control points, pass points, and centers must be pricked on the templates For this reason a somewhat different procedure from the above is used for radial plots to be used in conjunction with the Reading Plotter This different procedure and the different symbolization required are described more fully in chapter 6 The radial plot is laid and the positions of the points pricked in the top templates just as previously described Then all control and pass points and all radial centers are drilled through all the templates and the base grid or projection, using a No 80 drill in a special chuck The drill must be started exactly in the pricked point and held vertically (a jig is being developed to insure verticality during drilling) After all points have been drilled the plot is disassembled, the map manuscript is placed beneath the base grid or projection and the points are pricked through the base sheet into the manuscript in accordance with the third paragraph of this heading

This method of transferring points is also permissible and applicable to radial plots made for purposes other than for use with the Reading Plotter, particularly small template plots covering one or two manuscripts which may be laid directly on the manuscript projections without the use of base grids or base projections

### 43 RADIAL-PLOT ASSEMBLY OF SINGLE-LENS PHOTOGRAPHS WITH HAND TEMPLETS

The hand-templet method is used for the radial-plot assembly of single-lens photographs (either contact prints or ratio prints) comprising single flight strips or several parallel strips covering small areas. Where a comparatively small number of photographs is involved, the hand-templet method is practicable and provides a ready means of analyzing discrepancies and of adjusting the templets between ground control. Conversely, where there are many photographs to be laid between control, the hand-templet method becomes impracticable and mechanical-templet methods are preferable. In coastal mapping a project is often broken into many small areas by the indentations of bays and inlets and by islands. Under these circumstances, each of the small areas of the project has to be controlled and its radial plot assembled separately, hand-templet methods are practicable and often preferable (see 1591 and 1592).

With only a few deviations the same procedures for assembling radial plots with hand templets are followed for both nine-lens and single-lens photography. (See section 42.) These deviations are due to the difference in size of nine-lens and single-lens photographs and the differences between the multiple-lens and the single-lens cameras.

Three-point fixes for starting a radial plot, or section thereof, will not be available with single-lens photographs so often as with nine-lens photographs. Thus, it will be necessary for the photogrammetrist to plot short strips of photographs between control points without a fix from which to start. This can be done quite readily by making a preliminary assembly of the strip, taping the templets together, and then superposing the single strip of templets over the projection and noting the distance closure relative to the control points. The strip of templets must then be reassembled until the correct distance between the control points is obtained, after which it may be placed in position.

The single-lens photographs shall be checked for paper distortion and the templets corrected as stated in subject 431.

The side lap of single-lens photography is generally not sufficient to permit cross azimuths between adjacent flights. The flights are tied together by horizontal points and photogrammetric points in the side lap.

A minimum of six pass points should be pricked on each photograph. These should be distributed with three on each side of the flight line—in the area of the side lap with adjacent flights and opposite the radial center and the conjugate centers. On 9- by 9-inch photographs, two to four additional pass points should be pricked. These additional points should be far enough away from the flight lines so that strong positions will be determined by the intersecting radials. With reference to subject 422, there will not be an excessive number of radials when plotting single-lens photographs as the side lap and the end lap are generally less than with nine-lens photographs.

The templets should only be large enough to show the necessary photogrammetric information. By keeping to this minimum, unnecessary thickness of templet material is eliminated.

#### 431 CORRECTION FOR PAPER DISTORTION OF SINGLE-LENS PHOTOGRAPHS

Special fiducial marks for correction of paper and film distortion of single-lens prints made for radial-plotting purposes shall be used together with a master templet for correcting the radial lines prior to radial plotting. The special fiducial marks consist of notches in the focal plane frame of the camera (fig 4 16a), or short radials near the margins of

the print (fig 4 16b) at approximately  $22\frac{1}{2}^\circ$  intervals. Master templets printed on metal showing the correct positions of these fiducial marks will be furnished by the Washington Office. The method of correcting radials for paper distortion is similar to that employed with nine-lens photographs.

All the fiducial marks and the center cross of the master templet are traced on a thin vinylite sheet which is called a *guide* templet. This guide templet is taped to the underneath side of the sheet of plastic that is to become the plotting templet. One or two fiducial marks are also traced from the guide templet to the plotting templet, so that the two templets can be accurately reassembled at any later time. The combined templets are next laid in contact with the photograph and registered in position by means of the fiducial marks and the principal point. The combined templet is then rotated on the principal point until the fiducial marks for any one sector coincide, after which radial lines for that sector are traced, and similarly for each successive sector. If the special fiducial marks for a sector do not exactly coincide, the error is subdivided as explained in 4243a. This method is continued until all the radial lines in all the 16 sectors have been drawn. The guide templet can then be removed and used again for the succeeding photographs. The guide templet should be checked periodically with the master templet to detect any distortion that would necessitate the preparation of a new guide templet. The following precautions must be taken, however, in tracing and using the guide templet. *The guide templet must be marked when traced from the master templet and oriented on the photograph in a specific orientation as indicated (fig 4 16a) by the relative shapes of the 4 original fiducial marks (which show at the center of each side of the photograph) and which are exactly the same on the master templet as on the photograph and as indicated by the fiducial mark with double ticks in fig 4 16b.* This correct orientation is essential because the special fiducial marks may not have been inserted at exactly the same intervals around the margin and consequently corresponding marks on the guide templet and the photograph must be used together or the amount of paper or film distortion will not be correctly indicated.

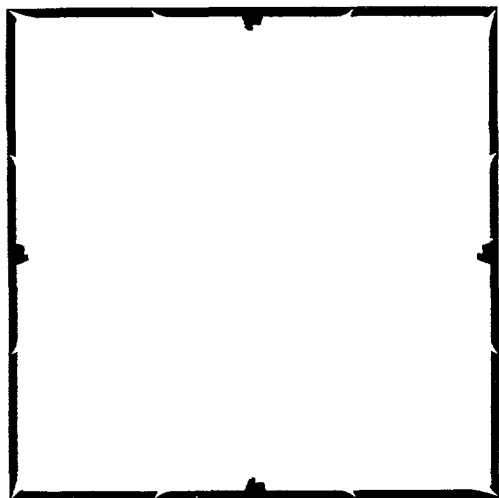

FIGURE 4 16a —Master Templet—Camera "O"

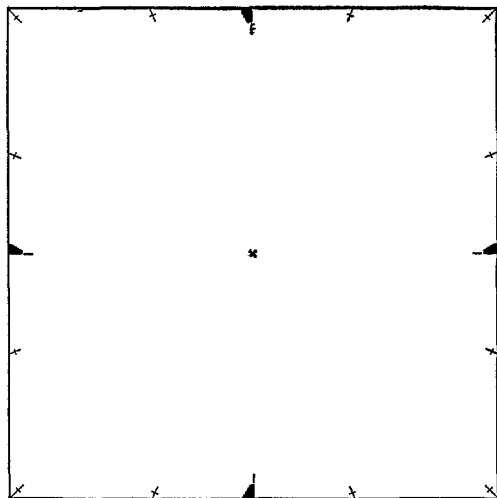

FIGURE 4 16b —Master Templet—Ratio Prints only

Special fiducial marks have been placed in cameras "D" and "O" and will be placed in other single-lens cameras used extensively by the Bureau, they will appear as notches extending into the otherwise black margin, with photographic detail in the notches

These are the marks illustrated in figure 4 16a which extend into the black margin of the figure. The principal point will be found, as previously, at the intersection of the lines joining the original camera fiducial marks. Having these new marks in the aerial camera will facilitate correcting the radials for distortion of the film as well as the paper.

When the special fiducial marks have not been placed in an aerial camera, they will be placed on ratio prints in the Washington Office but will not be placed on contact prints. In this case, a special glass plate containing these marks is placed in the negative holder of the ratio printer when the ratio prints are made. These special fiducial marks are short radial lines with ticks just inside the margin of figure 4 16b. The mark for orienting the guide templet has double ticks as illustrated at the top center of the figure. A center cross will also be placed on the ratio prints in this case as illustrated in figure 4 16b, and this center cross shall be used as the principal point in drawing the radials, but with the following precaution:

*The position of the center cross relative to the exact principal point as defined by the camera fiducial marks shall be checked for each photograph. If the position of the cross differs from the true principal point by more than  $2m$  millimeters where  $m$  is the ratio of enlargement, the photograph should be returned to the Washington Office for reprinting. The original camera fiducial marks which appear on the photograph but do not appear on the master templet (fig 4 16b), shall not be used for paper distortion corrections.*

Where the special fiducial marks have been placed in the aerial camera, the master templet will be identified with the same letter as the aerial camera, for example camera "D" or camera "O", and may be used for correcting paper distortion of all photographs taken with that specific camera. When the special fiducial marks are placed on ratio prints in the Washington Office, the master templet will be designated "Ratio prints only", and may be used for all ratio prints having special fiducial marks like those on the master templet regardless of what aerial camera was used for taking the photographs. The master templates will ordinarily be furnished for 2 or  $2\frac{1}{2}$  diameter enlargements and will have radials from their centers to the special fiducial marks, so that they can be used with photographs the same size or smaller than the master templates.

Shrinkage in photographic paper is extremely unpredictable. The shrinkage is subject to a large number of factors that produce an unsymmetrical shrinkage pattern which is usually not the same in magnitude nor direction for any two photographs. Cellulose acetate and posit type (cellulose acetate impregnated) paper have the same general shrinkage characteristics as paper, but with a lesser magnitude.

#### 44 RADIAL-PLOT ASSEMBLY OF SINGLE-LENS PHOTOGRAPHS WITH MECHANICAL TEMPLATES

The mechanical-templet method is generally used by the Coast and Geodetic Survey for radial plotting single-lens photographs (either contact prints or ratio prints) of relatively large areas where the distribution of horizontal control is such that the hand-templet method is impracticable. The method has been particularly useful in the preparation of relatively small-scale maps (1:125,000, for example) from a large number of photographs at a comparatively large scale, such as 1:20,000. No exhaustive tests have

been made by the Coast and Geodetic Survey to compare the accuracy of plotting between hand templets and mechanical templets. Hand templets are considered somewhat more accurate and are used almost exclusively for coastal mapping, which is usually done at a comparatively large scale, that is, 1:20,000 or larger. However, this does not imply that mechanical templets shall never be used for coastal mapping. The control requirements for mechanical templets are stated under heading 1592. The same photographic displacements and distortions have to be dealt with in mechanical-templet plots as are discussed in 421 and 431 for hand templets. For precise work the photographs must be checked for paper distortion and the templets corrected accordingly. Such corrections require that a hand templet first be made from which the mechanical templet is made.

Unlike hand-templet plots, all azimuth lines must be carried forward from the radial center because the mechanics of the method make it impossible to use more than one point near the center of the photograph. If the principal point cannot be identified on overlapping photographs, a substitute center is selected and used for both the radial center and the construction of azimuth lines.

There are two types of mechanical templets—spider and slotted. (The Coast and Geodetic Survey uses the spider-templet method.) The general methods of assembly are the same. Spider templets are constructed of assembled slotted metal arms. Slotted templets are constructed of rigid material in sheet form, such as 4-ply Bristol board or thin metal or plastic sheeting. The distortions of the materials used for both templets are so small that they can be disregarded.

#### 441 SPIDER-TEMPLET METHOD

The method of assembling radial plots with spider templets is economical because the templets are constructed of various parts (fig. 4-17) which can be unassembled and re-used. A slot in a metal arm replaces each radial on a hand templet. A metal stud fits into the slot with a small clearance so that the stud slides freely in the radial direction. The tolerance of the bearing surfaces is as small as machining practices will permit (0.002 inch).

The elasticity of the arms limits the size photograph that can be used without seriously affecting the mapping accuracy. This same elasticity takes up small angular discrepancies caused by tilt and small unavoidable inaccuracies acquired during the preliminary preparation of the photographs, the construction of the templets, and the plotting of control points. Large errors are immediately apparent if the templets fail to fit together without being forced into position.

##### *4411 Preparation of Office Photographs*

The office photographs are prepared as in subject 411. In addition, short radials are inked through the horizontal points and the pass points on each photograph (see 4244). Care and judgment must be exercised in the selection of pass points so as to prevent interference of the metal arms with the azimuth arms and with those to control stations and to the other pass points. The trial use of metal arms when the pass points are being selected is an aid in preventing arm interferences.

Six pass points are pricked on each photograph. These should be evenly distributed—three on each side of the flight line and opposite the photograph centers—in the side lap

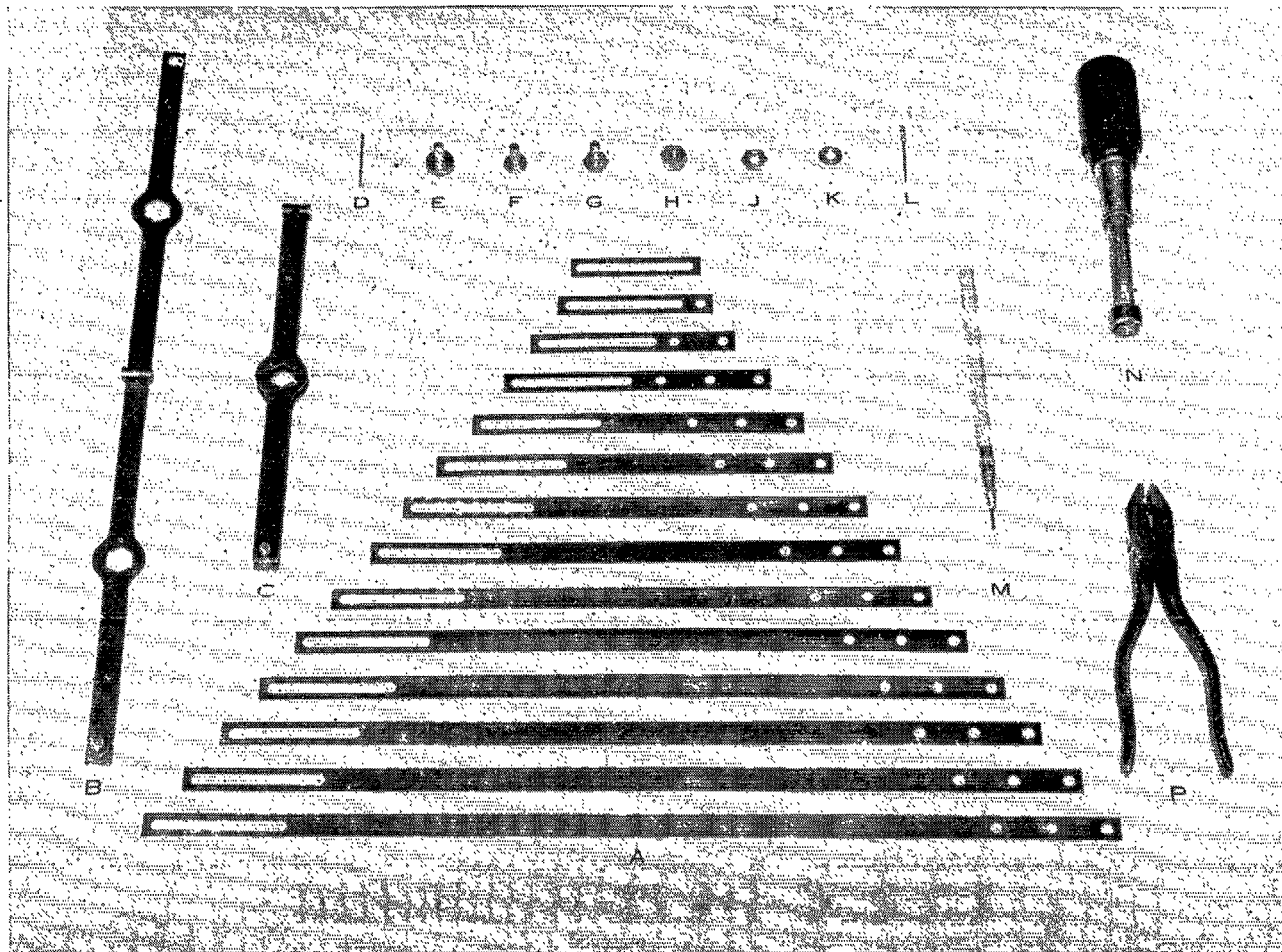

FIGURE 4.17.—Spider-templet parts and the tools for their assembly.

of adjacent flights. On 9- by 9-inch photographs one or two additional points can be pricked. On ratio photographs of approximately two diameters (18- by 18-inch), two to four additional points are recommended. (See fig. 4 18.) Care must be taken to prick these additional points far enough from the radial center and the azimuth lines to avoid interference between the metal arms. Judgment should be used as to whether or not any of these points are pricked in the side lap. When additional points are pricked, five cuts can be resorted to, instead of six, for some of the six required pass points on a photograph.

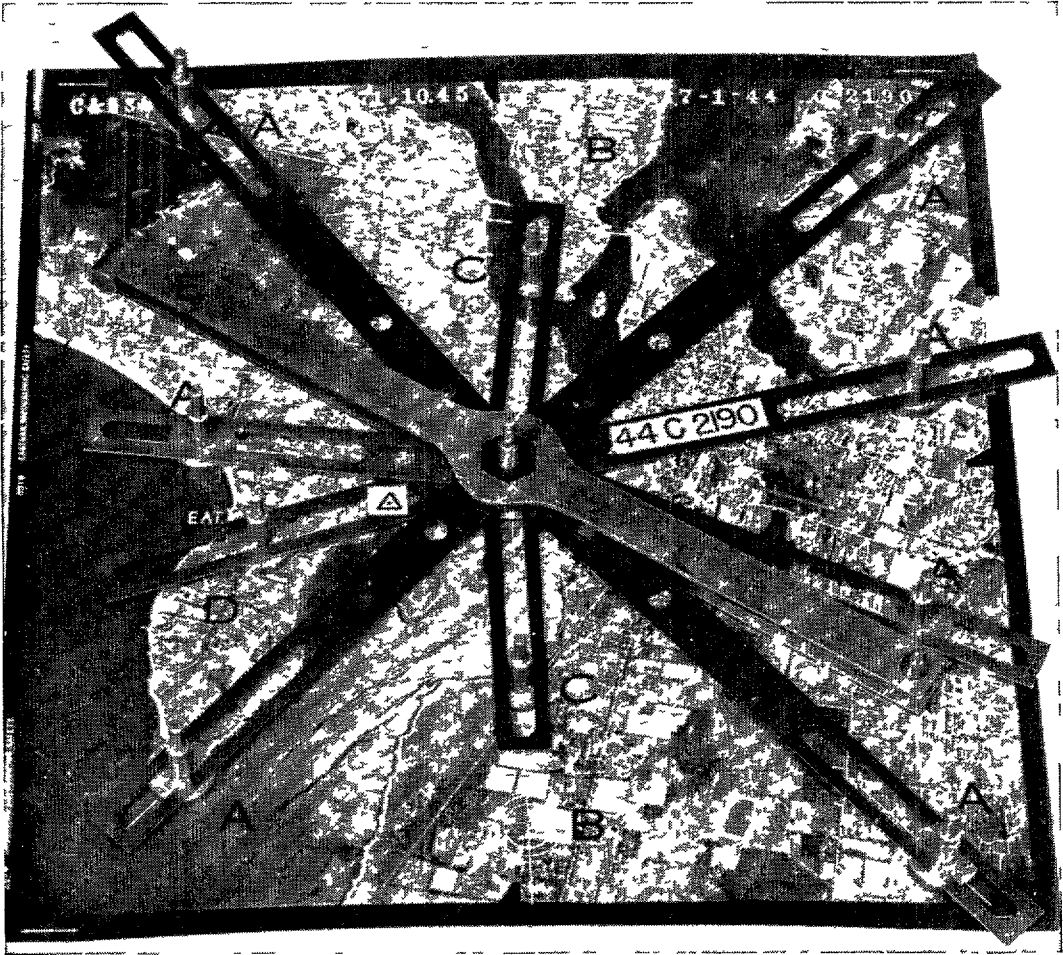

FIGURE 4 18 — Assembled spider templet

Irregularities frequently arise which affect the choice of pass points, such as

- (a) The presence of horizontal points in varying positions with respect to the overlap areas and azimuth lines
- (b) The stagger (or lack of it) of the photographs in the adjacent flight strips
- (c) The varying relative width of the side lap area
- (d) The presence or absence of suitable images for pass points
- (e) The special requirements of the particular project

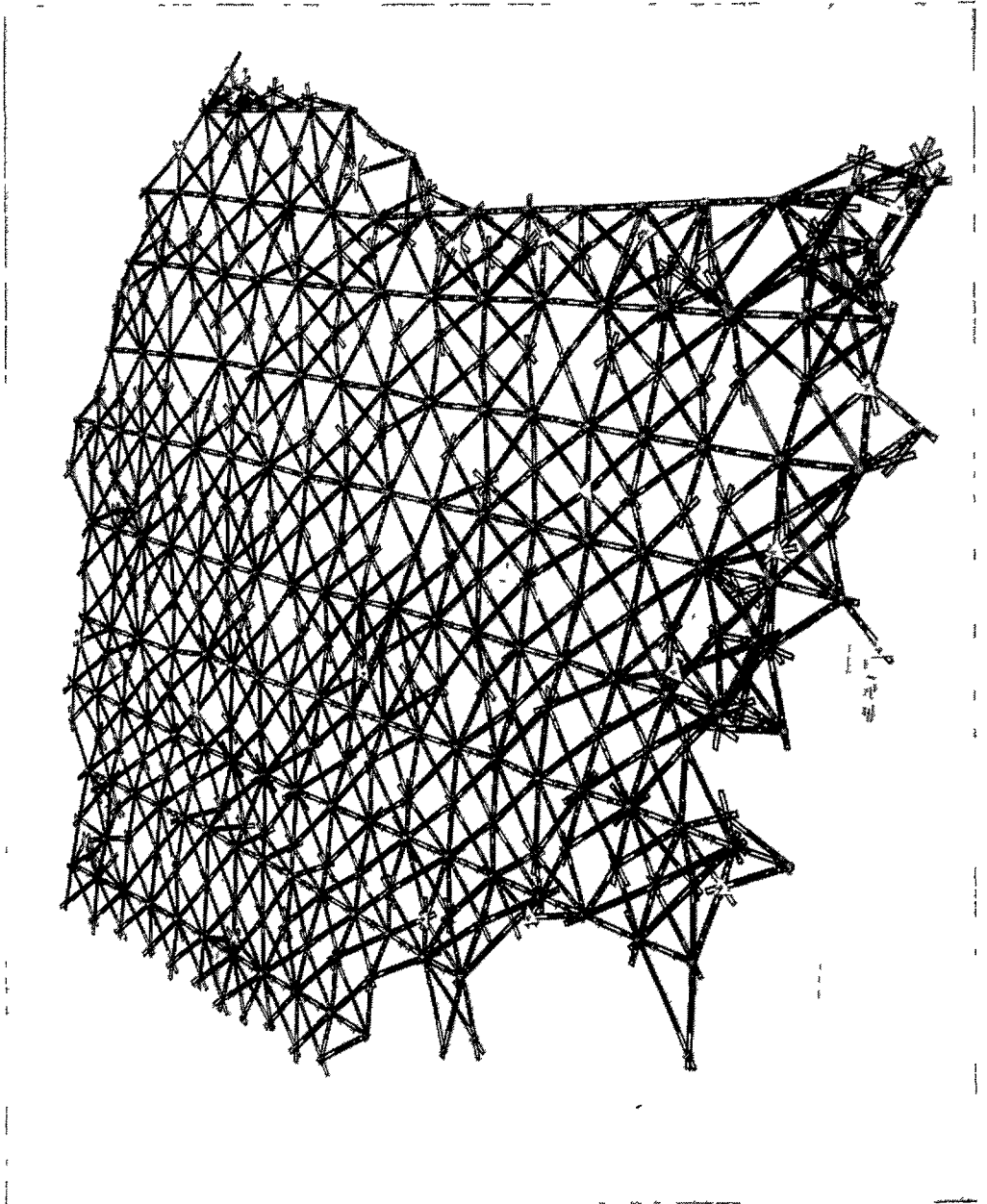

FIGURE 4 19.—Radial plot assembly with spider templets

#### 4412 Construction of Spider Templets

To construct a spider templet of a photograph, the photograph is placed on a special composition mounting board. A pin inserted in a hex bolt (see fig 4 17) is driven through the radial center until the head of the pin holds the stud firmly to the photograph. A tack hammer may be used, but the end of the handle of the socket wrench is preferred. In the same manner pins and studs are fixed on the azimuth lines a little beyond the



mid-point and on the radial lines through the circled points. The pin is never driven inside the circle, as to do so would destroy the image of the point. It is placed on the radial line just outside the circle. The selection of the location of a pin is based on the necessity of having the eventual radial position fall within the length of the slot in the arm. If the image is that of an elevated object or if the scale of the photograph is larger than that of the plot, the pin is placed toward the center of the photograph. If the scale of the photograph is smaller than that of the plot and if there is no appreciable elevation of the object, the pin is placed away from the center of the photograph. When the studs are all pinned in place, the lower half of the tension wrench is placed on the photograph over the hex base of the center bolt. Slotted steel arms are placed over the hex bolt and the studs, beginning with the azimuth arms and ending with the longest arm on the templet. After all the arms are in position, a hex washer and then two round washers are placed on the hex bolt, and the upper half of the tension wrench is folded over the templet, holding the hex washer firmly in place. A hex nut is then screwed to the top of the bolt, and tightened very firmly with the socket wrench. While the nut is being tightened, an equal force is exerted on the tension wrench in a counterclockwise direction so that no torque is transmitted to the radial arms. If any arms are binding on their studs, the nut should be loosened and retightened until the templet appears correct. The photograph number is shown on each templet, as are all horizontal points. Numbers can be written on Scotch drafting tape, and stuck on each templet near the radial center so that they can be read from the south or the east. The templet and the tension wrench are then raised from the photograph, the wrench taken off the templet, the studs and pins removed from the photograph, and the templet again oriented over the photograph. A careful inspection is made to see that each radial line on the photograph bisects the slot in its metal arm. This is a final check on the accuracy of the templet assembly.

Only a few templets lying in the best controlled area are constructed at the beginning of a plot, and these templets are assembled before any more are made. This is done to assure that the arms are generally of correct length (especially the azimuth arms) so that a large number of templets will not require reconstruction.

Interference between arms to horizontal points and to azimuth lines is rather common. Where this occurs it is necessary to decide which is more important to the radial plot—the azimuth line or the horizontal point. Generally the arm to the horizontal point should be retained. If there is a plethora of horizontal points or the marking or the plotting of the point is questionable, the azimuth arm is retained. In this case the horizontal point can be used as a check on the radial plot.

#### *4413 Assembling a Radial Plot with Slide Templets*

The manuscript projections and base grids are constructed on plastic sheeting as described in subject 413. Occasionally, however, a base grid is not used and the plot is assembled directly on the manuscript projection. Horizontal points are plotted in the usual manner, but each must be indicated with a large cross made by scratching two lines each about 1 cm in length at right angles to each other through the plotted point and filling the scratched lines with India ink or a grease pencil. This practice is necessary to retain the plotted position because the pins make large holes in the sheeting and destroy a pricked point or a small cross. The positions must also be shown with inked circles slightly larger than the base of a stud so that the position of the stud may be checked after the pin and the stud are in place. The base grid or the manuscript projection, is

laid on large composition boards placed on the plotting table. A pin inserted in a stud is carefully driven vertically through each of the horizontal points. The position of the stud is checked by means of the inked circle to ensure that the pin has been driven vertically and that it has not drifted to one side.

The best-controlled small area is laid first, beginning, if possible, with a templet controlled by two or more horizontal points. The area is extended until the next control is reached and is then adjusted by stretching or squeezing to fit this control. Adjacent templates can then be laid. The plot is assembled across flight and in flight, with little or no consideration of flight lines and with particular attention to control distribution. A graphic flight line photo index should be available while the templates are being assembled. While the radial plot is being assembled and adjusted to the control, each templet is tapped and the studs rotated in an effort to eliminate or distribute all strains and to cause each templet to lie flat without binding. Any arm or templet that cannot be relieved of unusual strain without transmitting this strain to other arms or templates should be removed, checked, and any errors corrected before again being fitted to the assembly. Large errors in the plotting or marking of horizontal points and pass points are readily seen; small unavoidable errors are taken up in the spring of the metal arms.

After the templates have been assembled and the best possible adjustment has been achieved, the positions of the radial centers and the pass points are transferred to the sheeting by inserting the special needle through the holes in the bolts and the studs. The length of this fine-pointed tool is adjusted so that a very small hole is pricked in the sheeting when the tool is pressed to its limiting position. A short pencil line is then drawn, pointing to each radial center and each pass point. Photograph numbers are written in pencil alongside the radial centers at the ends of each flight strip and at irregularities in any strip. Then the entire assembly of templates is removed and the radial centers and the pass points are marked with the appropriate symbols. Each photograph is oriented beneath the sheeting and inspected to check that all points have been marked and that each falls on a radial line on

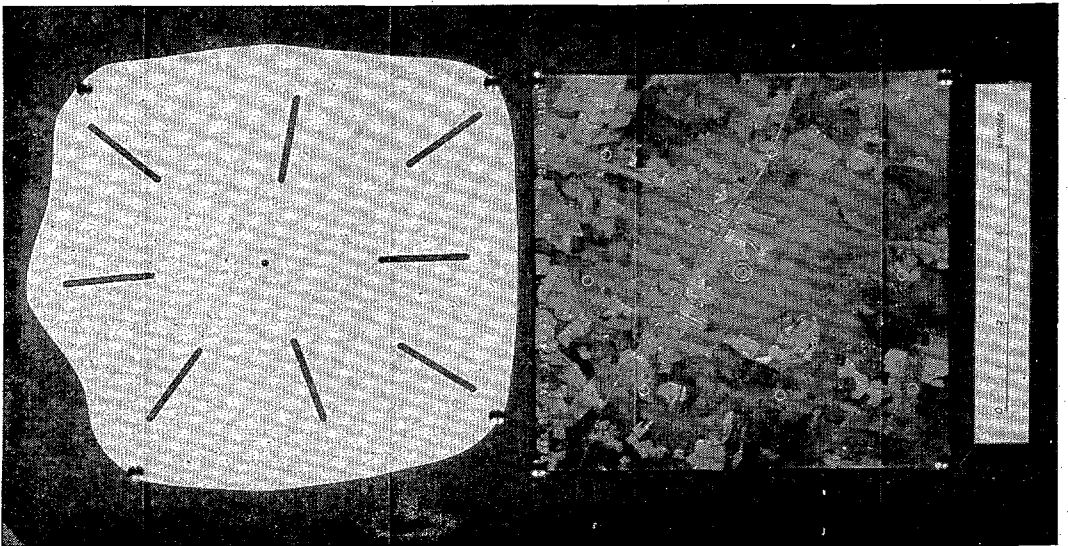

FIGURE 4.20.—A slotted templet.

the photograph. If any fail to do this, it indicates either that a templet loosened during the adjustment of the radial plot, or that one of the radial arms was the wrong length and caused mechanical binding to induce a local error. If either case exists, the cause must be found, corrected, and the radial plot re-laid to the nearest horizontal points. If the assembly is made on the map manuscript, the circles and the photograph numbers should be inscribed with blue permanent plastic ink on the back of the sheeting. Then the front surface should be washed with soap and water to remove the oil, dirt, etc., resulting from the metal templates and pencil marks. If the assembly is laid on a base grid, the points must be transferred to the map manuscript and marked as described in 4254.

#### 442 SLOTTED-TEMPLET METHOD

In the slotted-templet method of assembling radial plots, a radial slot replaces each radial on a hand templet and a round hole replaces the radial center. A stud similar to that used with spider templates fits into the slot so as to slide freely in the radial direction. The tolerance between the stud and the slot is approximately 0.002 mm.

##### *4421 Preparation of Office Photographs*

Slotted templates require the same preparation of office photographs as spider templates require (4411), except that the distribution of pass points is not so critical because there is less interference between the slots than between the metal arms. The points, however, have to be far enough apart or staggered so that their slots will not weaken the rigidity of any templet.

##### *4422 Construction of Slotted Templates*

Slotted templates should be made of a rigid smooth-surfaced sheeting that will not easily warp or bend and whose slots will not be indented by the studs when a slight pressure is exerted. Four-ply Bristol board is generally satisfactory. By waxing this board, friction and possible distortions caused by variations in humidity are reduced. The excess material on each templet is trimmed, reducing templet interference from sharp corners and friction.

For small areas and limited numbers of templates a portable hand slotter is satisfactory. In making a templet with a hand slotter, a photograph is taped face up on the sheeting and the radial center, pass points, horizontal points, and azimuth lines are vertically pricked through the photograph onto the sheeting. The photograph is then removed and the points are circled with pencil. The photograph number, horizontal points, and one azimuth line are identified. The center hole of the templet is then punched, preferably with a punch equipped with a retractable center point. The center hole of the templet is then placed over a metal stud of the same diameter. The templet is rotated on this stud, which slides in a groove of the slot cutter, and is pushed in or out until the center of the die is over a pricked point. The slot is then punched in the templet.

When a scale change is desired between the photograph and the templet, this correction has to be made graphically by drawing radials through the points and by proportionally extending or reducing the radials. Templet cutters have been constructed that can be automatically set to take care of scale changes. One of these cutters and its operation are described on pages 394 to 396 in the Manual of Photogrammetry (American Society of Photogrammetry).

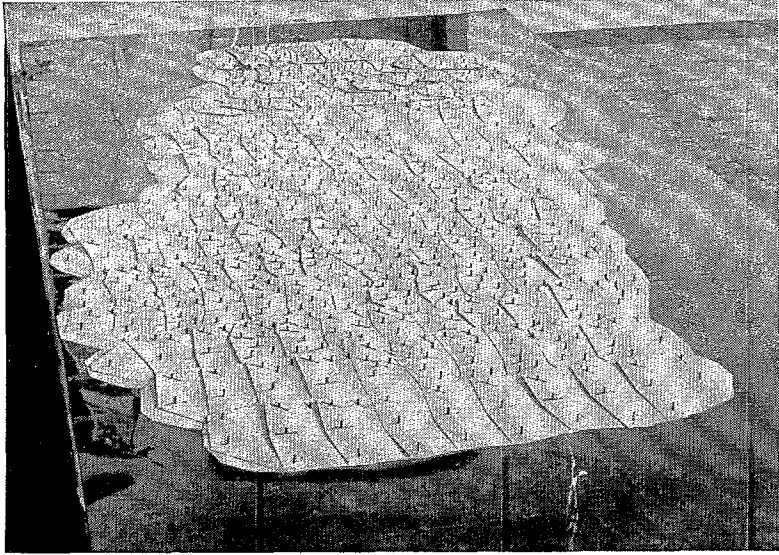

FIGURE 4.21.—Radial-plot assembly with slotted templets (Courtesy Soil Conservation Service).

#### 4423. *Assembling a Radial Plot with Slotted Templets*

The method of assembling a radial plot with slotted templets is similar to that of spider templets (4413). One possible difficulty, however, with slotted templets is that, as opaque sheeting is generally used for the templets, one cannot see the plotting sheet without taking up the templets. Consequently it is not quite so easy to detect the omission of horizontal points, slight errors in the plotting of horizontal points, and small errors in centering the studs which result in causing the studs to indent or cut into the sides of the slots. These difficulties are evidently not too important as slotted templets have been used just as extensively as, or possibly more extensively than, spider templets and with excellent results.

As with the spider templets, slotted templets provide a mechanical adjustment of the plot between ground control, and, because of the slight tolerance between slots and studs (442) and because of the fact that the paper can give slightly to the studs, the small and inevitable errors in radial directions tend to balance out.

### 45. DIRECT RADIAL PLOTTING

In direct radial plotting, the transparent map manuscript or the transparent plotting sheet is placed over each photograph and the radials are traced directly onto the manuscript. Thus, the radial plot is developed directly onto the transparent sheet without the use of templets. This method is older than the templet method and has been largely superseded by the latter, as templets afford a more ready means of adjusting the plot between ground control points.

Where adjustments are required in direct radial plotting, it is necessary to erase the radials and redraw them. The method, however, is applicable in many cases, as, for example, in the rapid plotting of single strips where exact positions and refined adjustments are not necessary, and for small accurate plots where ample control is available and little adjustment is required.

The instructions in this section are for accurate plotting by the direct method. This method of radial plotting may be used with either single-lens or nine-lens photographs.

As maps are laid out without regard for control, it may at times be advantageous to do the radial plotting on a vinylite grid laid out to use the control to best advantage and to disregard the individual map limits.

The general procedures for preparing the photographs, map manuscripts, and/or grids are the same as those described in section 41. Mounted nine-lens photographs are required for most accurate results, as distortions and transforming errors cannot be dealt with otherwise. The selection and placement of pass points are the same for nine-lens photographs as those described in subject 422. They are less critical for single-lens photographs than for the mechanical templet methods (4411) because there are no arms or slots to interfere. Azimuth lines are established as in subject 423.

The photographs are laid in the order of their strength—from those with strong three-point fixes to those with less control (see 425). As each photograph is placed under the transparent plotting sheet or manuscript, it is oriented so that the radials on the photograph bisect the circles of the horizontal stations marked on this sheet. Generally, each photograph is fastened to the table with tape in order to keep it stationary and the plotting sheet is moved around over the photographs and thus adjusted into position in a manner similar to the adjustment of the vinylite templates to the base grid in the hand-templet method (see 4253). After the photograph is correctly oriented, a radial is drawn on this sheet through each pass point and along each azimuth line. In order to keep the graphic error as small as possible, these lines should be as fine as practicable without unduly retarding the work.

Radials are inked through the horizontal points that have been marked on the photographs. Great care should be taken to draw a radial accurately through each marked point. The lines themselves should not be wider than 0.15 mm. Where the terrain is flat and the radial plot is to be assembled at the scale of the photographs, the radials need not extend more than 1 inch on each side of each point. In mountainous areas these radials must be slightly longer.

Chisel-edged colored pencil lead (Scripto) is suggested for drawing radials on the transparent plotting sheet. Different colors may be used for different flights. These lines can be easily removed with a damp soapy cloth. Waterproof drawing ink is recommended for the radials drawn from photographs whose positions and orientations are rigidly fixed by control stations.

Errors can be found easily and corrected if the strongest fixed photographs have been plotted first. A failure of the azimuth lines to be coincident indicates error. Photographs that are partly controlled or are without control will nearly always require some adjustment in order to get as good intersections as possible. This is usually obtained by replotting until a smooth adjustment is obtained of both azimuth and distance between fixed photographs.

If a plotting sheet has been used in lieu of the map manuscript the pass points and radial centers should be transferred to the map manuscript (see 416). The points are inked in accordance with figure 5-42.

#### 46 RADIAL-PLOT COMPLETION

Generally, only photo (-topo) points and those pass points that are required for the development of the plot between ground control are determined by the main radial plot. The

primary function of the main radial plot is to fix the position and orientation of each photograph accurately. After the main radial plot has been completed, it is still necessary to locate a large number of photogrammetric points. These include such points as detail points and photo-hydro points. These additional points are located by direct radial plotting on the individual manuscripts in accordance with the instructions in this section.

Detail points forming the main pattern for map delineation and photo points shall be selected, identified, and located on the map manuscripts under the supervision of the supervisor of the radial-plot section or the supervisor of the compilation section. With this supervision any photogrammetrist assigned the delineation of a map manuscript or a member of the radial-plot section can do this important work.

These points shall be inked in accordance with figure 5 42.

#### 461 IDENTIFYING PHOTO (TOPO) POINTS AND PHOTO HYDRO POINTS ON PHOTOGRAPHS

Photo (topo) points<sup>2</sup> and photo-hydro points are the images of recoverable control stations whose horizontal positions are determined by photogrammetric methods. These stations are selected or established by the field personnel and are indicated on the field photographs for location by the radial plot. They are for use in controlling future surveys of this Bureau.

Only photo (-topo) points that are located by the main radial-plot assembly are already marked on the office photographs (4116), the others are marked at this time. They are transferred from the field photographs to the office photographs. This transfer should always be made with the aid of a stereoscope (4117).

Each point must be indicated on at least three office photographs and preferably on four. A sketch showing the map limits and photograph centers is helpful in determining which photographs should be used so that the radials from them will form acceptable angles of intersections on the map manuscript (see 463).

The substitute station method (see 4114) results in a more accurate location of a photo station or photo-hydro station because it permits placing the station in its most favorable and useful ground position without the necessity of its being coincident with an identifiable point of ground detail. Identification of this type of station differs from the identification of stations to be used to control the photogrammetric compilation because, in this case, (a) the direction and distance are measured from the *substitute station* to the *station* to be located and (b) the azimuth may be referred to any recognizable and identified point of topographic detail, even though no geographic position is available for it, inasmuch as its position may be determined by the radial plot if it is identified properly on the photographs.

The identification of photo stations and photo-hydro stations as shown on the field photographs by the field parties shall not be permanently obliterated by the use of permanent ink during compilation. Where the photogrammetrist finds it desirable to ink circles on field photographs for compilation purposes, he shall use a water soluble ink and shall later remove it with a damp cloth, leaving the field photograph as originally submitted by the field party. This is important because field photographs are forwarded to the hydrographic parties to aid in the recovery of the photo stations and photo-hydro stations.

<sup>2</sup> For the sake of clarity the term photo (topo) point is used occasionally in this manual in most instances however it has been shortened to photo point and this latter term is the one more generally used. It is hoped that photo point will be eventually used in all instances.

The all inclusive term photogrammetric point is never abbreviated as such an abbreviation might conceivably cause confusion with the term photo point.

These photographs will, of course, be useless if the field-identified stations and details surrounding them have been obliterated by the office photogrammetrist

### 4611 Photo Points

Photo stations are recoverable stations on the surface of the earth whose horizontal positions have been determined by photogrammetric methods. They are established to provide control for future revision surveys. These stations may be natural or artificial objects, standard topographic marks specially set for this purpose, other standard Coast and Geodetic Survey marks (such as bench marks), and marks of other agencies not tied to the Federal control net.

The names of these stations are lettered by the field personnel on the field photographs and on all the necessary forms. In addition to Form 524 (see chapter 7) an identification card may be furnished for some stations. If Form 524 contains all the necessary information an identification card is not furnished. Form 567 (see chapter 7) is always furnished for landmarks and fixed aids to navigation.

These photo stations, together with the horizontal control stations already established by ground methods, provide the recoverable control at the required 1-mile interval along the shores of navigable waters.

Photo points are images of these stations. They shall be identified on the photographs by the same methods as other horizontal points except for the inking of the points (see fig 5 41) and shall be marked within 0.15 mm of their true position.

Besides the points of monumented stations and other objects located for the control of future surveys, the following also are photo points:

#### A FIXED AIDS TO NAVIGATION

Fixed aids to navigation are specially established to aid the mariner in navigating the adjacent waters. All permanent fixed aids to navigation (substantial structures such as those of steel and masonry) should be located by triangulation. Where for any reason this is impracticable, they shall be located by radial-plot methods along with the semi-permanent fixed aids. Regardless of which method of location is used, the field personnel are required to mark as many permanent and semi-permanent fixed aids on the photographs as possible. The permanent fixed aids located by triangulation shall be used to control radial-plot assemblies. The field parties shall be notified of all those permanent aids that cannot be held during the radial-plot assembly and their positions shall be investigated.

Form 524 is prepared by the field parties and forwarded for all those aids to navigation that are to be located by radial-plot methods. They are identified by the same symbols as topographic points (see fig 5 41) with the official name or number lettered alongside each symbol. This name or number is obtained from the field photographs or Form 524 and should be checked against the Light List.

#### B LANDMARKS

Landmarks on charts are used to aid in navigating adjacent areas. They are objects that are prominent as viewed from seaward. They can generally be identified directly on the field photographs although reference measurements are usually furnished also.

Each object that is identified as a landmark on the field photographs and for which Forms 524 and 567 have been prepared shall have its geographic position determined by radial-plot methods. The geographic position shall also be determined by radial-plot methods for these objects identified as landmarks and for which only Form 567 has been prepared and there is no adequate geographic position. In this instance Form 524 is not to be prepared by the photogrammetric office. Each landmark is named—generally the proper name or description of the object—and identified by the same symbols as topographic points.

## C AZIMUTH MARK POINTS

An azimuth mark is a marked station established in connection with a triangulation station in order to provide a starting azimuth for other surveys. The geodetic azimuth from the triangulation station to the azimuth mark is determined during the triangulation. The distance from the triangulation mark to the azimuth mark generally is determined only approximately. An azimuth mark point is the image of an azimuth mark on a photograph. Field personnel are required to identify all azimuth marks on the field photographs and to designate them by the names that are stamped on the azimuth marks.

The identified azimuth point is located by the radial plot. After the azimuth point is located, it should be checked by plotting the geodetic azimuth from the adjoining triangulation station. Where the adjoining triangulation station has been identified and used to control the plot, this check on the accuracy of location of the azimuth point is also a check on the accuracy of identification of the triangulation point, provided no office plotting errors are involved.

*4612 Photo-Hydro Points*

A photo-hydro station is a permanent or semipermanent station (usually some cultural or natural feature) located photogrammetrically for the control of subsequent hydrographic surveys. Photo-hydro stations are similar to photo (topo) stations with these exceptions. They (1) are not necessarily so permanent, but may be recoverable for only 1 or 2 years, (2) are spaced more closely, (3) are located only when hydrography is planned in the relatively near future, (4) are not described on Form 524, but are described on the field photographs, and (5) are generally not shown on the published maps. Photo-hydro stations are selected by the photogrammetric field party. Features recommended for use as photo-hydro stations are

(a) Such cultural features as stacks, tanks, towers, corners and ends of piers, corners and ends of sea walls, prominent cupolas, road intersections, fence or ditch intersections, or ends of jetties

(b) Such physical features as small detached rocks (which may be near or a considerable distance from the shore), distinctive pinnacle rocks, or ends and forks of narrow sloughs

A photo-hydro point is the image on the photograph of a photo-hydro station. Each photo-hydro point is identified on the field photographs by a fine pricked point indicated by a fine ink leader and a reference number of three digits. Field parties are authorized to number photo-hydro stations from 001 to 999 inclusive. It is possible that there may be omissions in the consecutive numbering of the photo-hydro stations on a project or subproject. This may occur when the Officer-in-Charge assigns blocks of numbers to separate field inspection parties operating at the same time, as, 001 to 399 to subparty A, 400 to 799 to subparty B, and 800 to 999 to subparty C. A new series of numbers 001 to 999 will be started on each project and will be repeated as often as is necessary. A brief description of each station is written directly on a field photograph by the field inspector. Only those features are selected for photo-hydro stations that—

(a) Can be positively identified without question on the photographs

(b) Can be recovered by the hydrographer within a period of 2 years, unless this time limit is changed by the project instructions

The office photogrammetrist shall strictly adhere to the following instructions

(1) The identification of photo-hydro points on office photographs and their transfer to overlapping photographs shall be done with a stereoscope

(2) The field identification of photo-hydro stations shall be examined stereoscopically for adequacy and the identification and marking of photo-hydro points on office photographs shall be done with extreme care. Any photo-hydro station which the photogrammetrist does not feel reasonably certain can be located within 0.5 mm of correct position



on the manuscript shall be rejected, and an accuracy of location of 0.3 mm is preferred. A station may be rejected because of error in the field identification, inability to mark the points accurately on the office photographs, or for other reasons. Where a station is rejected, a note to that effect shall be made on the field photograph immediately adjacent to the station number and in a different color ink.

(3) The identification of photo-hydro stations shall not be obliterated by the inking of circles or shoreline for compilation purposes (see 461). This is important, as field photographs will be forwarded to the hydrographic parties to aid in the recovery of the photo-hydro stations. The photographs will, of course, be useless if the station points have been obliterated by the office photogrammetrist.

In some instances the project instructions will require the selection and the identification of photo-hydro stations by the photogrammetric offices without field inspection. In this case the office photogrammetrist must endeavor to select objects which will meet the following conditions. This work shall be done with the aid of a stereoscope.

(1) The objects must be definite and recoverable by the hydrographic party.

(2) The objects must be spaced and situated so as to be of maximum use for hydrographic control.

(3) The objects must be in accessible places that can be reached by boat. On an exposed rocky coast, for example, objects clear on the photographs, such as pinnacles, may be useless because they cannot be reached by boat or cannot be approached after a boat landing is made.

(4) The objects must be visible from seaward or be subject to marking so as to be visible from seaward.

#### 462 MARKING DETAIL POINTS ON PHOTOGRAPHS

If an aerial photograph of absolutely flat land without any elevated objects were to exact scale and without any tilt whatsoever, the photograph would be equivalent to an orthogonal projection (see 321) of ground details. All the details could then be copied directly from the photograph onto the map manuscript by adjustment to two or three control points for the scale and orientation of the photograph. However, as most photographs vary in scale because of tilt and relief of the ground, it is necessary to detail from the photograph by comparatively small sections—the sizes of the sections depending on the magnitude of the deficiencies in the photographs. That is, when the tilt is slight, and the variation in relief is slight, comparatively large parts of the photograph can be detailed from one adjustment to the map manuscript, but where any one of these deficiencies is exaggerated or accentuated, the size of the part of the photograph that is to be detailed from one adjustment becomes smaller and smaller.

Detail points are selected by office personnel and are used for adjusting photographs to map manuscripts during delineation procedures. Great care must be used in determining the distribution of these points and in marking them, as the geographic position of 90 percent of the well-defined detail on a map manuscript must be correct within 0.5 mm (0.02 inch) of its true position to meet the Coast and Geodetic Survey requirements. These points should be selected near important detail at the same elevation as the detail and, at the same time, should form a convenient framework for adjusting and tracing all the detail from the photographs. They should be marked on the photographs with pass-point accuracy where there are ample well-defined images on the photographs. Conversely, in wooded areas where few, if any, well-identified points are available, they will have to be

indicated as accurately as practicable Their transfer to the various photographs is generally made with the aid of a stereoscope (4117)

The high-water line and immediate alongshore areas are of first importance to the Coast and Geodetic Survey Detail in these areas should be given first consideration for the distribution of detail points for map delineation In addition detail points should be distributed along such linear topographic detail as drainage lines, stream junctions, ridge crests, bluffs, roads, railroads, road intersections, etc

The required density of detail points depends on the topography and the closeness of the scale of the photograph to the scale of the map manuscript A ratio reflecting projector

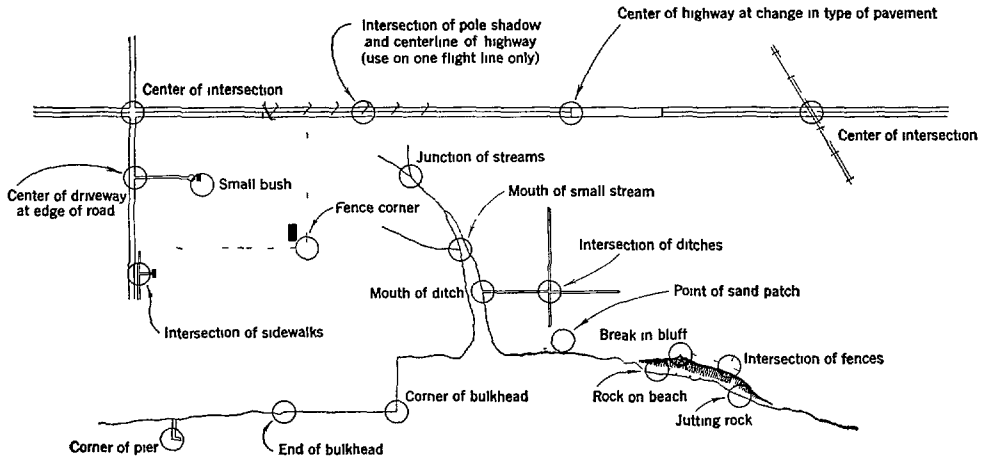

(a) Recommended

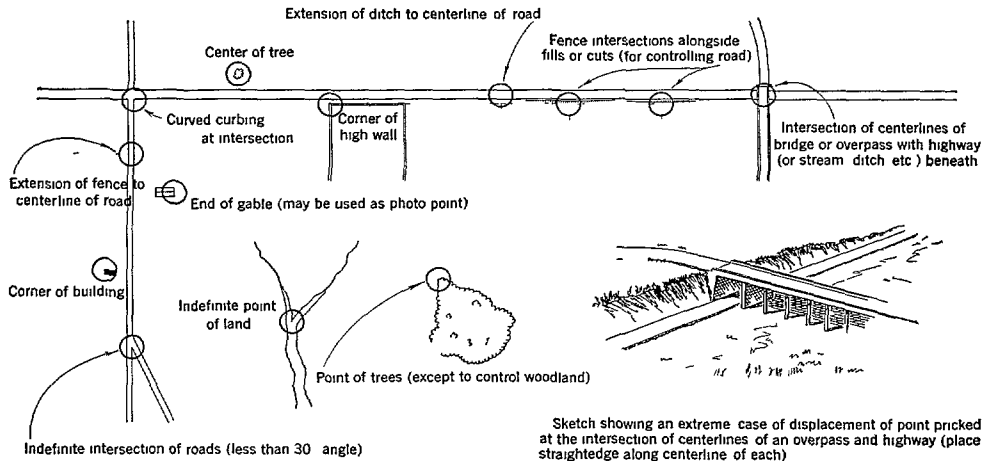

(b) Not recommended

In general detail points should be at the same elevation as the topographic feature being delineated When necessary and especially in precipitous or wooded areas points that would ordinarily be considered too indefinite may be used Often small distinct points that are not readily identifiable may be seen on photographs These may be used as detail points if they are at the same elevation as the topographic feature being delineated

FIGURE 4 22 —The selection of detail points

can be used to compensate for scale differences. There is no way, however, to compensate for displacement due to relief. Consequently, a small amount of proportioning is still sometimes necessary. The judgment required for adequately spacing the points comes from experience gained from delineating map manuscripts. In flat marsh areas the points may be widely spaced. Where there are discrepancies in the distance between points and the trouble is only scale, the ratio reflecting projector shall be used to correct these discrepancies—the number of detail points need not be increased. As the terrain becomes more rugged, however, points should be spaced closer together at sharp breaks in the terrain and in accordance with change in grade, etc.

Each point must be marked on at least three office photographs and preferably on four. A sketch showing the map manuscript limits and the photograph centers is helpful in determining which photographs should be used so that the radials from them will form acceptable angles of intersection on the map manuscript (see 463).

The discrepancy in distance between the two detail points on a photograph and the same points on a map manuscript should not, generally, exceed 1.0 mm. Wherever necessary, additional detail points shall be added in order to reduce a greater discrepancy to this amount or less. In less important areas that are void of cultural features or void of shoreline that is closely approached by vessels, more latitude is allowed in the adjustment of the distance discrepancies greater than 1.0 mm.

It is important that a detail point have very nearly the same elevation as the near-by features that are to be delineated. This may be demonstrated by computing the elevation which might cause a given relief displacement. In the following examples for nine-lens photographs, 0.02 inch (which is the maximum amount of displacement allowed well-defined points of detail on map manuscripts) is used for the relief displacement. The conclusions show the maximum differences in elevations at 6 inches from the radial center that can be tolerated between two objects in the immediate area of a detail point so that the delineation within this area is within the required accuracy. Any greater differences in elevation at this distance from the radial center would necessitate the selection of more detail points.

Formula (see 3232)

$$h = \frac{d_e \times H}{r}$$

In this formula,

- $h$  = difference in elevation (in feet)
- $d_e$  = relief displacement (in inches)
- $H$  = flying height (in feet)
- $r$  = distance from radial center (in inches)

#### Examples

1 10,000-scale nine-lens photograph

$$h = \frac{0.02 \times 6,875}{6}$$

$$h = 22.9 \text{ feet}$$

1 20,000-scale nine-lens photograph

$$h = \frac{0.02 \times 13,750}{6}$$

$$h = 45.8 \text{ feet}$$

## 463 LOCATING POINTS ON MAP MANUSCRIPTS

The accuracy of location of photogrammetric points on map manuscripts must be such as to meet these standards

(a) The National Standards of Map Accuracy as discussed in section 12 The National Standards of Map Accuracy apply to the positions of points on the published map and thus the reduction from manuscript scale to publication scale may be taken into account

(b) Coast and Geodetic Survey standards, which require that all photo stations shall be located within 0.3 mm (0.012 inch) and all photo-hydro stations shall be located within 0.5 mm (0.02 inch) of correct geographic position *on the manuscript*

Thus the Coast and Geodetic Survey standards for photogrammetric station accuracy are somewhat higher than the National Standards of Map Accuracy This is because these photogrammetric stations are used to control hydrographic surveys at the same scale as the photogrammetric manuscript and to provide the positions of landmarks and aids to navigation on nautical charts

The graphic method of locating photo points and detail points on map manuscripts is the same for nine-lens and single-lens photographs regardless of the method of radial-plot assembly

Radial lines should first be inked on each photograph so that they bisect each horizontal point and pass point These lines should be approximately 5 to 8 cm in length and should not be greater than 0.15 mm in width Pigment ink is generally preferred as it can be removed if desired

A photograph is then placed under a map manuscript with its radial center in coincidence with the corresponding position on the manuscript The map manuscript (or the photograph) is oriented about this center until the horizontal points and pass points are bisected by their respective radials on the photograph Radials are then ruled on the map manuscript, bisecting the points to be located The radials (0.1 mm wide) are generally no longer than 3 cm Mechanical pencils with colored lead are very satisfactory The colored lines made with this lead can easily be removed with a damp cloth

The location of each point is determined by the intersection of three or more radials at a point The angles of intersection of two of these radials should be between 30° and 150° Theoretically, the nearer the angle approaches 90°, the stronger will be the location of the point Additional radials serve as checks

A photogrammetric point whose radials do not intersect in a single point should not be accepted Instead, the identification of this point should be checked on each photograph If the point is too indefinite to be accurately transferred from photograph to photograph with a stereoscope or is not identified within the accuracy requirements, it should be deleted Sometimes small areas will be covered by only two photographs This will occur more often with single-lens photographs than with nine-lens photographs because of the difference in side lap In this case photogrammetric points must be located by two directions only and the identification and marking of the points must be done with extreme care, as errors in preparation of the photographs will not be indicated by two-direction intersections Photogrammetric points located by only two intersections should be designated on the manuscript by green circles—in the case of detail points or pass points, green circles should be substituted for the blue circles specified in figure 5.42 in the case of photo (-topo) points and photo-hydro points, 3 mm green circles should be drawn around the black station circles

Because of transformer errors and paper distortion in nine-lens photographs and paper distortion in large ratio prints of single-lens photographs, these photographs often cannot be oriented under the manuscript so that all the main radial-plot pass points and the ground control points can be held at the same time. Where this occurs, the photogrammetrist must remember that these distortions have been corrected and compensated for in the main radial plot. Therefore, he shall follow this procedure:

(a) He shall hold the position of the center of the photograph as determined by the main radial plot.

(b) He shall rotate the photograph under the manuscript so as to hold those main radial-plot pass points that lie in the direction of the particular detail points that are to be located. Thus, one photograph might be divided into four or more segments and rotated to hold all the main radial-plot pass points in one segment at a time while tracing the radials to the detail points in that segment (see **4253**).

#### **464 ESTABLISHING PHOTOGAMMETRIC POINTS FOR MAPPING WITH THE READING PLOTTER**

The requirements for radial plots for use with the Reading Plotter are different than stated in this chapter as regards the number and arrangement of photogrammetric points and the symbolization on office photographs, templates, and base grids or base projections. These requirements are stated in **6244**. All radial plots for the Reading Plotter are made with metal-mounted photographs.

## CHAPTER 5 MAP MANUSCRIPT DELINEATION

A delineated map manuscript is the most accurate stage of map construction, no copy can be of greater accuracy. Its distinction lies in its completeness and accuracy of position rather than in its appearance.

The portrayal of features on a map manuscript is necessarily abbreviated because the manuscript is very small relative to the ground area portrayed. The selection of the topographic and hydrographic information to be taken from aerial photographs and the delineation of this information in correct position on a map manuscript require a knowledge of the principles of photogrammetry, the ability to interpret the photographs correctly, and the ability to draw the various symbols accurately for the features they represent. The accuracy of a map manuscript must comply with required standards, otherwise it becomes misleading and valueless for its specific purpose.

Before attempting to delineate a map manuscript, a new photogrammetrist should practice using plastic inks and drafting map symbols and freehand lettering. This is essential because of the special requirements of the Coast and Geodetic Survey and because of the difficulty in drafting on plastic sheeting with permanent plastic inks.

All planimetric and topographic manuscripts shall be compilation drafted, unless project instructions state otherwise. All shoreline manuscripts shall be smooth compilation drafted, unless project instructions state otherwise (see 51).

Compilation-drafted map manuscripts must be complete, accurate, and legible, but since they are completely redrafted for publication, extreme refinements in drafting are not required. These manuscripts must contain complete information for the smooth draftsman, but certain of the symbols may be simplified (see figs 5 21 through 5 47). Smooth compilation-drafted manuscripts are not redrawn prior to reproduction and printing, therefore, they must be comparatively finished drawings ready for reproduction.

### 51 CHARACTER OF THE DRAFTING

A compilation-drafted map manuscript must be *accurate, legible, and neat*.

1 *Accuracy*—The accuracy attained by the personnel in the radial-plot section can be lost during the delineation of the map manuscript if the photogrammetrists are not experienced in drafting, if they do not exercise painstaking care, and if they do not have the “habit” of accuracy.

2 *Legibility*—Clear-cut opaque lines and minimum space tolerances are required for reproduction. Each photogrammetrist engaged in drafting a map manuscript must realize that photographic copies, rather than the original manuscript, will generally be used and read by others.

Each photogrammetrist is not expected to be familiar with reproduction routine or requirements, but it is necessary that each manuscript is of such character that it, and its photographic reproductions, can be read accurately. All lines, symbols, and lettering must be opaque, and minimum reproduction space tolerances must be observed. Where the maps are to be reproduced in color, it should be possible to make color separation plates directly from blue-line prints of the manuscripts without redrafting or adjusting any part of the manuscript.

3 *Neatness*—Clean, well-proportioned map manuscripts distinguish the work of experienced photogrammetrists.

The character of the drafting on a smooth compilation-drafted map manuscript has certain refinements relative to a compilation-drafted map manuscript. The smooth com-

pilation-drafted manuscript is more legible because the symbols are not so abbreviated and because specific line widths and gages are observed. A smooth compilation-drafted manuscript should be extremely neat, clean, and well-proportioned in all respects as it is the final drawing.

### 511 USE OF INSTRUMENTS

The drafting instruments essential to photogrammetric offices are listed and described in subject 141. Their methods of use for drafting on plastic sheeting are described herewith.

#### 5111 Drafting Pens

For drafting on plastic sheeting, ruling pens, contour pens, and drop bow-spring pens should be filled so that the permanent plastic ink stands approximately one-eighth of an inch deep from the point when the pen is held in a vertical position. No ink should be left on the outside of the blades.

Most of the difficulties encountered while drafting with plastic ink can be attributed to the following causes:

*a The type of pen*—The ruling pen should be the type described in 1411A. The contour pen is described in 1411B. The drop bow-spring pen is described in 1411C. All three types should be sharp and clean.

*b The position of the pen*—Ruling pens should be held in a position approximately vertical to the sheeting with the blades parallel with the direction of the lines. Any slight inclination of the pen should be in the direction in which the line is being inked. Contour and drop bow-spring pens must be held vertically, they must not lean. A rather light touch is required with the contour pen so that it can rotate freely without undue friction.

*c The improper control of width of lines*—The thumbscrew alone does not control the width of the line. Slow movement of the pen, excess ink, and dirty plastic sheeting tend to increase the line width. Excess pressure on the sheeting will cut the sheeting, thus clogging the pen and causing an uneven flow of ink. Too much pressure on the blades of a ruling pen against a triangle or similar instrument will cause a line of uneven width.

*d The properties of permanent plastic ink*—(See 512)

#### 5112 Steel Pen Points

Where steel pen points are used with plastic inks on plastic sheetings, the drafting technique is somewhat different from that used with waterproof drawing ink—that is, the pen is held more nearly vertical.

Those inexperienced in inking on plastic sheeting have a tendency to exert too much pressure on the pen point in an effort to make the ink flow. This produces varying line widths. The nibs should never be spread to make a wider line, a larger pen point should be used. With a light uniform pressure the ink should flow off the point.

The experienced draftsman knows with which make and type of pen he can obtain the best results. However, the crow-quill pen is believed to be the best all-purpose pen for general delineation. Hunt No. 104 is perhaps best for fine or minute detail and descriptive notes.

The best results are obtained with points that have been kept clean and free from an accumulation of dried ink and minute particles (such as lint) that are easily caught between the nibs. When a pen point has proved to be satisfactory it should be given the same care as other small drafting instruments.

A pen point can be "inked" with another pen used for that specific purpose, or it can be dipped and the ink lightly wiped from the back of the point. Only a small amount of ink is desirable. In general the ink should only come up to the air hole in the point.

## 512 INKS

Permanent plastic ink is used to draft all map manuscripts as it has a rather permanent bond and does not rub off easily. It will chip, however, if used too heavily. The ink flows more evenly and makes a firmer bond on plastic sheeting that is free of grease, fingerprints, and dirt. Ink smears or blots must be removed immediately and completely as this ink tends to stain plastic sheeting. Any of this stain that is not completely removed will photograph. The ink should also be removed from all instruments and celluloid triangles and curves. A cloth, wet or dry, with acetate ink on it must not be left on or near a map manuscript of acetate or other plastic, if this is done and the manuscript is covered with a dust cover overnight or for a few days, it will severely curl or buckle the manuscript.

Because of the density and the drying properties of permanent plastic ink, only a small amount (see 5111) should be put in a pen at any one time. This ink dries rather rapidly and becomes too thick and gummy to flow. Because of these qualities it should be issued in either  $\frac{1}{2}$ - or 1-ounce bottles. To keep the ink at the proper consistency, special thinners are used for different colored and black inks.

Craftint permanent inks are the most satisfactory for use on plastics that are available at this time and are used exclusively.

Craftint No. 150 black permanent plastic ink with No. 150 thinner shall be used in preference to other Craftint inks for all work to be permanently inked in black. This ink is available in three grades: light, medium, and heavy. The medium grade is generally used.

Craftint No. 111 ink with the No. 111 thinner is used for colors other than black. The No. 111 inks can be cleaned off with the No. 111 thinner or solvent. For this reason, the No. 111 inks are preferable for radial lines on templates. They produce a sharp line which can be wiped off with the No. 111 solvent and the template re-used. Manuscripts on which Craftint No. 111 inks have been used must not be cleaned with ammonia. They may be washed lightly with soap and water. The photogrammetrist will generally need two mixtures of each color of the No. 111 ink, each mixture with slightly different amounts of thinner. A comparatively thick ink will be needed for use in ruling pens and a thinner mixture for use with crow-quill pens.

Craftint inks may be purchased directly from the Craftint Manufacturing Company, Cleveland 10, Ohio.

The colored plastic inks formerly prepared in the Washington Office are no longer used.

The Government Printing Office is now experimenting with permanent plastic inks in black and in colors. It is expected that these inks will soon be available to all government agencies. Trial of these inks in the Washington Office indicates that they are superior to any other plastic inks. A supply of these inks will be furnished to each photogrammetric office, with instructions for their use, as soon as they are available. It is expected that the Government Printing Office inks will eventually supersede all other permanent plastic inks for map manuscript delineation.

Johnson's "Snow White" white ink and Weber's Cadmium Yellow pigment ink are the most satisfactory inks for accentuating photographic detail and for inking azimuth lines on photographs. A cloth dampened with water can be used to remove these inks and other pigment inks without marring the photographic detail. These inks may be purchased directly from Johnston's Snow White Products, P O Box 207, Mumford, New York and F Weber Co, 1220 Buttonwood Street, Philadelphia 23, Pennsylvania.

Certain symbols, as specified in this manual, must be drawn in non-permanent ink so that they can be removed from the manuscripts at some stage of map production. These



symbols shall be drawn either in waterproof drawing ink or in one of the non-permanent plastic inks

The colors of ink to be used for the drafting of planimetric, shoreline, and topographic manuscripts are specified in section 54

513 LETTERING

Lettering on map manuscripts shall be plain Gothic—that is, single strokes of even width Capitals and lower-case letters, both vertical and inclined, shall be used (see fig 5 1)

**FREEHAND LETTERING  
FOR USE ON  
MAP MANUSCRIPTS**

**VERTICAL**

**INCLINED**



FIGURE 5 1—Coast and Geodetic Survey freehand lettering for use on map manuscripts

In general, lettering shall be done freehand with guide lines either placed under, or lightly penciled on, the map manuscript The shape, proportions, and strokes of each letter should be known, and a sense of proper spacing should be acquired by each photogrammetrist so that legible balanced words and sentences can be made with speed and ease It is not intended that exact letter sizes shall be used on map manuscripts, and measurements certainly shall not be made to ascertain that the letters are a certain size, however, the following sizes serve as a guide for more uniform lettering on all map manuscripts

<i>Control stations</i> .....	6-point capital letters
<i>Road objectives</i> .....	6-point capital letters
<i>Descriptive notes</i> .....	6 point capital and lowercase letters
<i>Grid data</i> .....	8-point capital letters
<i>Joins Survey No T-</i> .....	8-point capital letters
<i>No contemporary survey</i> .....	8-point capital letters
<i>Projection data</i> .....	10-point capital letters
<i>Geographic names</i> .....	6- to 30-point capital letters
<i>Manuscript title block</i> .....	(see fig 5 46)

Descriptive terms and their modifiers that are simply type-identifying or explanatory, and which are in no sense proper names, shall not be capitalized. Examples that occur frequently are canal, ditch, mud, pile, bulkhead, ruins, cemetery, etc. All such terms and legends shall begin with a lower-case letter and any preceding modifiers shall begin with lower-case letters. Abbreviations of such terms and modifiers should generally begin with lower-case letters, although discretion must be used with abbreviations, inasmuch as usage has established capitalization for some abbreviations, such as (a) abbreviations of directions, N, E, etc., (b) abbreviations of colors, B, G, R, etc., (c) where the first letter of each of two or more words is used, PO, LSS, PD, etc., and others. This paragraph is to be complied with, even where it is in conflict with examples elsewhere in the text and in the illustrations. The nonabbreviated words and terms in figure 5 45 should be followed but the capitalization of the abbreviations should be used with discretion.

#### 514 SYMBOLS AND ABBREVIATIONS

The symbols and abbreviations for use on photogrammetric manuscripts are reproduced in figures 5 21 through 5 47.

As both topographic and planimetric manuscripts are generally not available to the public until they have been redrafted and published, many abbreviated symbols are used on them. With practice these symbols can be easily read or interpreted.

Shoreline manuscripts are generally not redrafted prior to public use, therefore, their symbols must be complete.

The use of the required symbols and abbreviations is particularly important as confusion often results where they are not used or where symbols are drawn so poorly as to permit misinterpretation.

#### 52 PHOTOGRAPH INTERPRETATION

Photograph interpretation involves the recognition of physical and cultural features from their images on aerial photographs. The accuracy of interpretation is affected by a number of factors, such as the angle of the photograph (oblique or vertical), the season, the scale, the weather, and the development and printing. Experience is essential to understand these factors and to acquire the ability to interpret and to read the photographs accurately. Even then, considerable care and common sense must be exercised or erroneous conclusions may be reached.

Only the most general guidance can be offered for photograph interpretation, because the variation in color tones, ranging from black through shades of gray to white, depends on the amount of light reflected from the physical and cultural features. Where a great deal of light is reflected, that area on the photograph is light-colored, where the light is scattered or absorbed, that area on the photograph appears dark. For example, water will range from black to white or light gray on photographs.

Shadows represent areas from which little or no light is reflected. Often relief features, such as ridges and canyons, are outlined by shadows so that the form of the terrain is vividly presented.

Because only a general interpretation can be made of small-scale photographs of unfamiliar territory, an inexperienced photogrammetrist should be trained with large-scale photographs of familiar territory containing prominent cultural features that can be easily recognized, such as fences, power line towers, sidewalks, and houses. A photograph should be oriented for study so that the shadows fall toward the observer. (See fig 5 2)

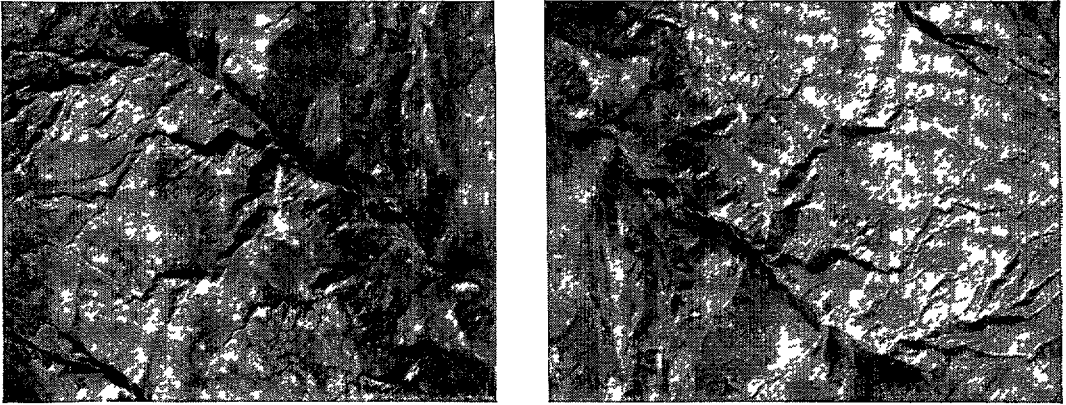

FIGURE 52—The correct and incorrect shadow orientation of the same photograph

It is frequently helpful to view part of a photograph from the direction of its perspective center in order to obtain the most vivid impression of the terrain features (The perspective center is located on the line perpendicular to the photograph at the principal point and at a distance from the surface of the photograph equal to the focal length) This method of viewing is sometimes more important than the orientation of photographs so that the shadows fall toward the observer. The practice of viewing photographs from the perspective center applies particularly to oblique photographs and to the wing sections of nine-lens photographs. This phenomenon is due to the fact that the mind is accustomed to interpreting perspective views, and a true perspective is formed on the retina of the eye if the eye is placed at the perspective center, in fact, the impression obtained is the same as the observer would get if he were looking from the aircraft at the time the photograph was taken (See also 332)

While the photogrammetrist is obtaining experience in photograph interpretation, some method of checking the results is needed to answer his questions as to problematic features, to confirm his conclusions, and to give him self-reliance. If there is opportunity for the photogrammetrist to compare the actual terrain with the photographs, direct and accurate interpretation of the features is possible. As it is not always possible for each photogrammetrist to have this field experience, field-inspected photographs are used. The photogrammetrist interprets the office photographs and compares his interpretation with the notes on the field photographs. To a lesser degree a check can also be made by comparing photographs with existing topographic maps.

## 521 FIELD INSPECTION FOR INTERPRETATION OF PHOTOGRAPHS

The Coast and Geodetic Survey generally requires a *precompilation field inspection* of photographs in order to obtain certain data that are unobtainable from the photographs alone, such as deletions, geographic names, boundaries, and land lines, and to clarify details that the photogrammetrist might misinterpret. Occasionally, manuscripts of some areas, such as Alaska, are compiled without prior field inspection. It is the responsibility of the photogrammetric office, however, to compile the manuscript as completely and accurately as possible regardless of the amount or quality of the field inspection.

The photogrammetrist must carefully study and use all field inspection notes in his stereoscopic interpretation of the photographs. Field inspection notes are generally made

with reference to typical features or sections of the terrain, with the expectation that similar features can be interpreted in the office by analogy

Field inspection notes are usually made with reference to features that cannot be correctly interpreted by office examination of the photographs alone. For this reason, the field inspection notes should be followed by the office photogrammetrist and rarely disregarded. However, field inspectors occasionally make mistakes, and when the office photogrammetrist, after careful study of all the data, is sure that a field inspection note is in error, he may disregard it. In the latter case, he shall state the facts in the Descriptive Report and, if field-edit surveys are to be made, he shall generally refer the item to the field editor by means of a note on the discrepancy overlay.

## 522 STEREOSCOPIC OBSERVATION OF AERIAL PHOTOGRAPHS

Stereoscopic observation (see also 33) is essential for accurate photographic interpretation, therefore, all photogrammetrists must be proficient in the use of the stereoscope. Mapping projects are photographed with sufficient overlap to provide for stereoscopic observation of the entire area, and both field parties and photogrammetric offices are provided with suitable stereoscopes.

## 523 CHARACTERISTICS OF PHOTOGRAPHIC DETAIL

It is impossible to state all the characteristics of photographic details, however, some general characteristics are given in the following headings to aid in the interpretation of photographs.

### 5231 *Physical Features*

#### A RELIEF

Relief is revealed on aerial photographs by drainage, shadows, and stereoscopic examination.

Geologists state that 90 percent of the relief features of the earth have been formed almost wholly by stream action. Thus the drainage patterns formed by the stream systems are extremely important as guides to the general character of the terrain. The streams form an elaborate tributary system, branching in a manner similar to the trunk and the branches of a tree and dividing and subdividing the terrain by valleys, canyons, gorges, and gullies. The direction of flow can usually be determined by the fact that on most streams the acute angles between the main stream and its tributaries point downstream, thus revealing the general direction of the slope of the immediate terrain.

Even though drainage outlines the relief features on an aerial photograph, the terrain still appears flat and featureless if there are no shadows. Shadows aid in creating the illusion of depth by accentuating surface irregularities and slope changes which might otherwise be unnoticed. With shadows, relief features, such as ridges and canyons, are accurately outlined. In rugged areas ridges are accentuated by shadows so that the main ridge and its appendant ridges form patterns similar to those of drainage. The direction of the slope is indicated by the acute angles the appendant ridges make with the main ridge, these angles point upgrade. Although shadows emphasize the relief, they at times obscure important features or make photographic interpretation extremely difficult, and specifications for aerial photography are such as to reduce shadows so far as possible by requiring photography in the middle of the day. Therefore, the use of a stereoscope is required for obtaining the three-dimensional impression and for studying surface irregularities and slope changes.

### B DRAINAGE

Drainage is recognized by its characteristic winding and branching patterns (see 5231A) and by the vegetation concentrated along its course. Where drainage is hidden from view in woodland areas it can usually be recognized by the variation in the density of the vegetation. In cultivated land or pastures, drainage can be traced by the irregular narrow band of brush or trees along its course.

The identification of drainage should always be done with a stereoscope. Viewing the photographs pseudoscopically is frequently helpful where difficulty is encountered in identification. However, at times it is impossible to identify drainage in any other way than by field inspection.

### C VEGETATION

The appearance of vegetation depends upon the region, the season of the year, and the time of day the photographs were taken. Because of these factors it is impossible to define the photographic characteristics of vegetation to fit all cases, however, there are several general characteristics that should be recognized.

Evergreen and coniferous trees of all sizes usually appear more regular in pattern and darker in tone than other vegetation. The shadow of an individual tree tapers to a point, except on mature trees where the top is somewhat rounded. Individual crowns can often be identified in dense stands.

Deciduous trees vary in gray color tones, depending on the species and the time of year. Their shadows lack the uniformity of appearance of evergreen and coniferous trees. The top of a dense stand of deciduous trees appears flat even when examined with a stereoscope, therefore, individual trees generally cannot be identified. A definite effort is made by the Coast and Geodetic Survey to take photographs during a season when the ground is not obscured by the leaves of deciduous trees. Areas of deciduous trees, nevertheless, can be identified by their color and texture although it may not be possible to identify individual trees.

Brush is identified by its irregularity of growth and its gray tones. Practically no shadows are apparent. Even when viewed stereoscopically, the height of brush is usually negligible.

Cultivated vegetation is recognized by the regularity of various patterns. Trees, such as those in orchards and groves, are evenly spaced in rows and are generally divided into areas, in each of which the trees are of a uniform size. Cultivated crops often have regular row patterns that follow the contour of the land. Freshly plowed fields appear very dark because of the rough surface and damp soil. Fields from which crops have been harvested are light gray. Often grain and hay fields will be dotted with shocks.

### D ALONGSHORE AREAS

The alongshore area includes the shoreline and the land and water areas immediately adjacent thereto. The interpretation from aerial photographs and the mapping of physical and cultural details within the alongshore area is extremely important to the Coast and Geodetic Survey because this information is vital to the mariner. The width (normal to the shore) of this area varies according to the nature of the shore, but may be said to include the water area as far offshore as it is practicable to map rocks, aids to navigation, and other such features from photographs, and to extend inshore to cover physical and

cultural features visible from the water and thus of value to the mariner in showing him the character of the shore. This strip may be of very limited width in shore areas of deep water and precipitous bluffs or may be very wide where the gradient of the terrain is almost flat. In general the physical features of the adjacent land are indicative of the character of the alongshore areas. That is, low flat coastal areas are usually bordered by continuous beaches with gentle slopes and accompanying sand bars or shoals. Irregular rugged coastal areas with numerous bays and headlands are bordered with intermittent steep beaches and rock outcrops, and reefs and ledges may be expected in the adjacent water areas.

Shoreline is the line of contact between land and water. In tidal areas the shoreline is the mean high-water line (the line of intersection of the plane of mean high water with the ground). The mean high-water line can generally be detected on the ground and then identified on the photographs by the field inspection. The identification of the mean high-water line is, of course, much easier when the photographs are taken at the approximate time of high water. The field identification of the mean high-water line furnishes the photogrammetrist sufficient information for accurate stereoscopic interpretation in the office. The low-water line can be directly identified only when the photographs are taken at the approximate time of low water.

The mean high-water line can generally be directly identified on photographs if it coincides with a marine cliff or if the photographs were taken at the approximate time of high water, and provided the shoreline is not obscured by marine vegetation, such as mangrove, marsh, and swamp.

The exact position of the mean high-water line is very difficult to determine on gradually sloping beaches. Often two lines of slight discoloration will be seen along such beaches. The inshore line is the line of wave-washed debris. Storm waves at especially high tides build up debris well above the reach of ordinary waves and tide. This line will usually be a little more distinct than the outer line which is the mean high-water line. When this type of area is studied under a stereoscope, the change in the slope of the beach can usually be seen at the line of the storm-deposited material, and the beach appears more nearly level for a distance inshore. Along an open beach where the magnitude and force of the waves are uniform, the two lines will be approximately parallel. In some areas where the force of the waves is broken before reaching the shore, the mean high-water line and the storm-water line may nearly coincide. In other areas where the magnitude and force of the waves vary, the distance between the two lines will vary.

The mean high-water line can usually be readily identified along rocky coasts where the adjacent water is deep, as these areas are often accompanied by marine cliffs and an extremely narrow beach. Rock ledge is usually identified by its light gray color, rough texture, and surface crevices. Where this type of rocky coast is accompanied by many offshore islands, rocks, and underwater shoals, the mean high-water line and the storm-water line are generally the same and may be identified by the occasional deposits of debris.

In marsh, mangrove, and other swamp areas, the mean high-water line (the line of intersection of the plane of mean high water with the ground) is not visible on the photographs, nor can it be readily located by planetable. Therefore, in these areas the outer line of vegetation visible to the mariner at mean high water is mapped as the shoreline. This shoreline is best determined by stereoscopic observation.

Mangrove is a tropical plant that grows only in salt water. It is generally found along muddy shores, tidal estuaries, and salt marshes. It is usually dense and appears darker than most alongshore vegetation.

Marsh that is not flooded is usually distinguishable on the photographs, generally it is light gray—lighter than the adjacent water areas or the adjoining vegetation. Flooded marsh is often very difficult to interpret as various light conditions in combination with the density of growth and the season of the year cause its tone to range from very light to dark.

Most dry sand appears light-colored, wet sand is gray or even black. Gravel appears in an even tone of gray and is generally found where there is a narrow or a very small beach.

Mud may be distinguished by its flatness, by its mottled appearance, and by its characteristic branching drainage patterns.

Streams flowing across a beach are often deflected by the action of ocean currents.

Surf and breakers appear white.

Where submerged rocks can be seen in water they appear as dark irregular spots that interrupt the regular wave pattern. On photographs showing a heavy sea, rocks can usually be identified by waves breaking over them. Several successive photographs should be studied to ascertain whether the breakers are caused by rocks or by gusts of wind. If waves are observed breaking at the same point on successive photographs, an obstruction is probably the cause, but that is no indication that the obstruction uncovers at high water, or even at low water. If there is a light swell and the waves are breaking on an obstruction, the obstruction is near the surface or awash.

Patches of seaweed also appear as dark spots in the water, but their outlines change with varying wave conditions and are generally more smooth in appearance than those of rocks. Waves usually do not break where there is only seaweed.

Sand bars and shoals usually occur off sand beaches and are light-colored—the lightest tones are on those parts of the bars where there is the least depth of water. They can also be identified by breakers along their offshore sides. Bars or shoals, spits, and hooks are depositional features that point in the direction of the current. Storms can change the positions or shapes of any of these features and can obliterate any of them. Shoals may be visible in only a limited part of a photograph where the surface reflection is at a minimum.

If clear water, swamp, and marsh all appear on the same photograph, the clear water is generally darkest. Swamp is slightly lighter in tone—approaching the tone of flooded marsh—and marsh that is not flooded is the lightest in tone.

Muddy water appears light-colored. Currents can often be recognized by the color contrast between sediment-laden or muddy water and clear water.

### 5232 *Cultural Features*

#### A RURAL AREAS

All roads, unless they are bitumen surfaced, are good reflectors of light. As a result, roads generally appear as gray or white lines. Improved roads show regularity in width with long tangents, easy curves and clean-cut outlines. Unimproved roads are irregular in width with sharp curves and indefinite outlines.

Railroads have clean-cut outlines and are generally long straight lines between easement curves of considerable length. There are few reverse curves that do not have intervening tangents of several hundred feet. On large-scale photographs electric railroads can easily be identified by the power poles spaced alongside the railroad. Railroads usually appear much darker than roads.

Trails are very irregular in width and outline and meander over the terrain, appearing intermittently in heavily forested areas and frequently terminating at water crossings.

Side roads that branch from main roads generally lead to houses or other farm buildings. Most houses have some shrubbery or trees around them and, as a result, the entire outline of each house may not be distinguishable. Other farm buildings are seldom obscured by trees or shrubbery.

Fence lines are generally identified as straight dark lines because of the vegetation that grows alongside the fences. A fence itself ordinarily is not visible.

Telephone lines and branch power lines can seldom be identified except under the most favorable conditions, such as where shadows are cast by the poles on smooth-surfaced concrete roads. Trunk transmission lines constructed with steel towers can be easily identified. The towers can be clearly identified by their shadows and concrete footings.

#### B URBAN AREAS

Cities, towns, and villages with their buildings and networks of streets are not difficult to identify, and the individual units that form these networks can also be easily identified if they are not obscured by trees.

Buildings and structures are identified by their definite shapes, or outlines, and shadows. The business district is generally void of vegetation except for parks and grounds of public buildings.

Houses are generally small buildings surrounded by yards with shrubbery and shade trees. Often the entire house or a portion of it is obscured by foliage.

Churches are distinguished by their spires and shadows. Often in older city districts churches have cemeteries adjoining them.

School buildings vary in size and shape but generally have adjacent playgrounds and athletic fields.

Unusually large buildings, such as factories and warehouses, are distinguished by railroad sidings, tanks, smokestacks, stock piles, waste dumps, and parking lots. They are generally located near road, rail, or water transportation facilities.

Structures are generally distinguished by their unusual shapes and open construction.

### 53 ORIENTATION AND ADJUSTMENT FOR DELINEATION <sup>\*</sup>

Map manuscript delineation from aerial photographs by graphic methods, as discussed in chapters 4 and 5, consists of (1) the orientation and adjustment for scale of photographs by means of a network of photogrammetric points and (2) the transfer from photographs of details around these control points. This is similar to the field method of mapping by planetable in that points or objects are first located in position and then the map details sketched around or between points. In delineating from photographs, the "sketching" phase is more accurate as the photographs can be held in position by means of the detail points<sup>1</sup> and the details traced exactly in shape and position.

Delineation of the map details by the photogrammetrist must include (1) a careful study of the field and office photographs for interpretation of details, (2) the selection and location by radial-plot methods of detail points to control the delineation accurately, and (3) the actual delineation or transfer of map details from the photographs to the manuscript. It is for this reason that photogrammetrists must be thoroughly trained in photographic interpretation and Bureau needs as regards what is to be shown on the manuscript.

<sup>1</sup> During the delineation procedures all ground control points and pass points serve also as detail points but those located on elevated objects must be used with caution therefore, in this chapter all such points are called detail points.

Ⓐ Radial Plot means "radial compilation" — a cardinal rule for delineation



- POINT ON PHOTOGRAPH
- ⊙ POINT ON MAP MANUSCRIPT

Note All adjustments are made radially

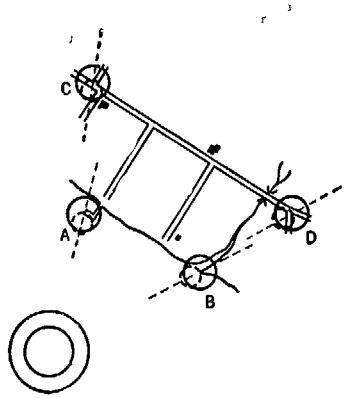

a A map manuscript is oriented over a photograph with both radial centers coincident. The detail is shown in its position on the photograph. Note the difference in scale between the photograph and the map manuscript.

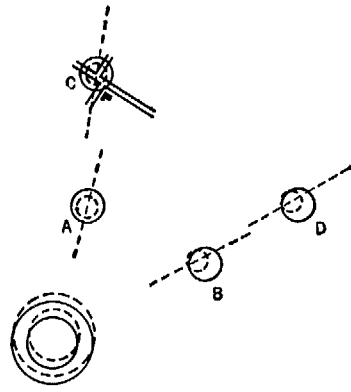

b The map manuscript is adjusted so that C is coincident and D is aligned.

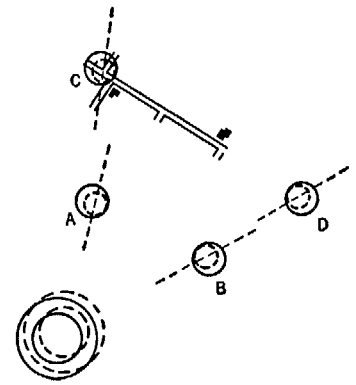

c C and D are aligned and adjusted.

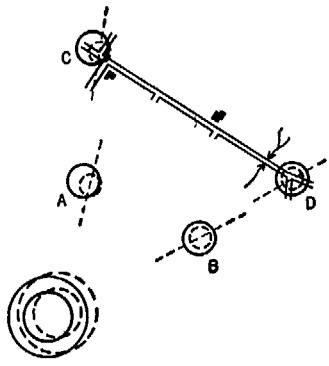

d D is coincident and C is aligned.

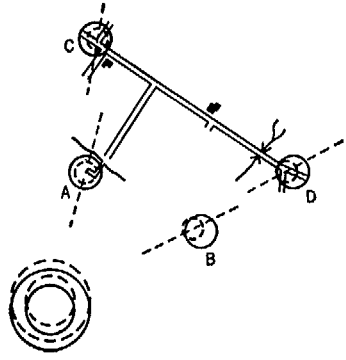

e A is coincident.

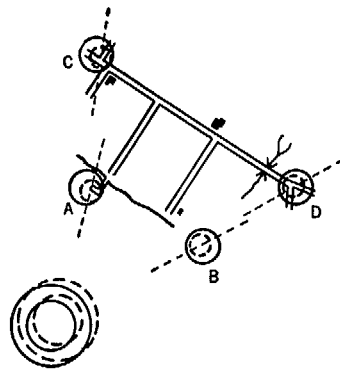

f A and B are aligned and adjusted.

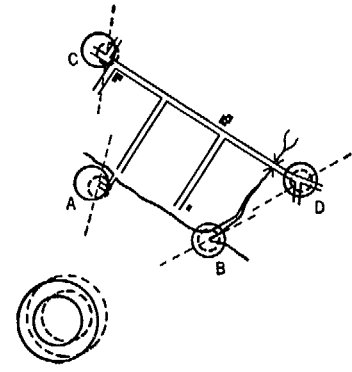

g B is coincident.

FIGURE 5-3—Manual orientation and adjustment for delineation

Only limited areas can be delineated from any one orientation of a map manuscript to a photograph, unless the terrain is flat and the photograph has no appreciable tilt or difference in scale from the map manuscript

Because of the required end lap and side lap, only the central part of each photograph shall be used for delineation. This reduces the number and magnitude of errors caused by displacement and indistinct definition.

### 531 MANUAL ORIENTATION AND ADJUSTMENT

Detail points required for delineation shall be located in accordance with **462** and **463** (see also **4253**). In selecting and locating detail points, a diagram showing the map manuscript limits and the photograph centers helps in determining which photographs should be used so that the radials will form acceptable angles of intersection on the map manuscript.

For delineating map details, the map manuscript is first placed over a photograph with the radial center of this photograph coincident with its radial center on the manuscript (See fig 5 3a). While holding the centers coincident, the map manuscript is oriented to a detail point in the area to be delineated. Generally the common detail points on the map manuscript and the photograph will be in the same relative position in a limited area around the selected point. The map manuscript may have to be slightly adjusted in a radial direction to bring the point on the photograph coincident with its position on the map manuscript (See fig 5 3b). The details in the immediate vicinity of this point are then traced. It is possible that two or three of the near-by points will also exactly coincide after one point is coincident on the photograph and the map manuscript. In such a case the detail within the area formed by these points can be delineated without further adjustment, providing there are no great differences in elevation (see **462**) within the area. If the immediately adjacent points on the map manuscript do not exactly coincide with those on the photograph, adjustments must be made. These adjustments are made by gradually moving the manuscript from detail point to detail point while constantly maintaining radial direction (See fig 5 3c through 5 3g). In important areas if the discrepancy between detail points is 10 mm or greater, an additional point or points are required to reduce this discrepancy (see **462**).

Many photogrammetrists prefer to delineate linear features, such as roads and railroads, first. When this is done, any necessary adjustments are made between pairs of detail points along the feature, as in fig 5 3b through 5 3d.

In some instances a sufficient number of detail points cannot be selected and located to reduce the adjustment to less than 10 mm between points. If such an area is relatively flat, the control may be subdivided with spacing dividers (**1414B**). The distance between two detail points is subdivided and the points of division marked in pencil on both the photograph and the map manuscript. After the photograph is radially oriented, the corresponding points on the photograph and the map manuscript are consecutively brought into coincidence for delineation.

### 532 MECHANICAL ORIENTATION AND ADJUSTMENT

Ratio reflecting projectors (see **143**) are used to enlarge or reduce photographs to the scale of the map manuscript for delineation. Only scale adjustments can be made with this machine—where relief is present, additional detail points must be selected and located as previously discussed. Where the terrain has no appreciable elevation differences and the

photograph has little tilt, all common detail points within a limited area coincide and delineation is relatively simple

A projector should be used in a darkroom to make the photographic image sharper so that more accurate work can be done. The photograph is oriented in the holder so that its image is projected on the horizontal table in a convenient position for delineation. The lens distortion of each projector must be known and the work limited to that more central part of the optical field where the distortion will not affect map accuracy. Most projectors have a cross etched on the copy glass that is projected on the tracing table to indicate the center of the optical field. The center of the photograph must be coincident with this cross where precise radials are to be traced or where the delineation requires adjustments in a radial direction, as for relief displacements. If a photograph is too large for the center and the cross to be coincident, it should be so arranged that the particular radial passes through the center of the cross.

## 54 DELINEATION OF MAP MANUSCRIPTS

The Coast and Geodetic Survey prepares three principal types of maps from aerial photographs (15) and the photogrammetrist must be familiar with the requirements for each. The requirements for the delineation of these three types of maps are stated in this section and are applicable in all cases except when deviations are authorized in the project instructions.

All map manuscripts shall be drawn with permanent plastic ink (512), regardless of the color. Shoreline manuscripts shall be delineated in black in their entirety, planimetric manuscripts and topographic manuscripts shall be delineated in various colors. All legends shall be lettered in the same color ink as specified for the symbols they describe. Descriptive notes shall be lettered in black.

All lettering relating to land features or fixed objects above mean high water shall be in vertical letters. All lettering relating to water areas and features below mean high water shall be in inclined letters. (See 513)

Elevations of rocks, regardless of reference datums, shall be in inclined figures. Spot elevations, including fourth-order trigonometric and fourth-order spirit (fly) levels, and contour elevations shall be in inclined figures. Elevations of bench marks and non-monumented recoverable points of third-order or higher accuracy shall be in vertical figures. (See 513)

### 541 GENERAL STATEMENT

Most map manuscripts are prepared by the Coast and Geodetic Survey at comparatively large scales and important coastal features can be shown with but little generalization. Even so, much detail on the photographs cannot be mapped and many irrelevant details apparent on the photographs are omitted to avoid congestion. After a manuscript is completed, there should be no necessity for reference to either the photographs or related data in order to interpret the information shown thereon. All the information should be self-explanatory.

A map manuscript is essentially a symbolized record of the physical and the cultural features of the land, but it must contain other data necessary for its proper interpretation. These additional data consist of legends, geographic names, names of control stations, contours, various explanatory notes, etc.

<sup>12</sup> The omission of the unimportant features detracts nothing from the maps value, their inclusion not only creates dangerous exaggerations of position but also clutters the map with a multitude of unnecessary detail, making it difficult for the

The line weights, widths of features, and sizes of symbols specified in the text and in the illustrations of this manual apply to all manuscripts, with the following specific exceptions *when the scale of a topographic manuscript is greater than 1 20,000, the minimum widths of roads and similar double line features and the minimum sizes of buildings and structures shall be increased by the ratio of 20,000 over the denominator of the manuscript scale For example, the specified minimum widths and sizes shall be increased 20 times on a 1 10,000 scale topographic manuscript This specification does not apply to line weights and symbols in general, the sizes of rocks awash, islets, and small features should be increased slightly but line weights and most symbols, except for the minimum widths and sizes stated above, shall be drawn the same on all manuscripts*

Topographic maps are usually smooth drafted at 1 20,000 and published at 1 24,000 or 1 25,000 Project instructions will state any unusual publication scale

Where the area of a topographic map includes one or more shoreline maps that are being concurrently compiled, the shoreline manuscripts are generally compiled at the scale of 1 10,000 Reduced scale copies (usually 1 20,000) are then made of the shoreline manuscripts so that the area covered by these manuscripts can be traced directly onto the topographic manuscript, thus eliminating duplication in compiling In such cases, the sizes of symbols on the shoreline manuscript shall be drawn according to the scale of that manuscript and not according to the reduced scale of the topographic manuscript When the photogrammetrist traces detail from a reduced shoreline manuscript, he will find some features smaller than the required sizes Keeping the exact geographic positions of such features, he shall enlarge them to the minimum size (See 5413 and 5446A )

The photogrammetrist delineating the map must be familiar with the accuracy requirements The transfer of the features from photographs to the manuscripts must be made with the utmost care to avoid inaccuracies in position To make this accurate transfer more certain, the accentuation of these features on the photographs is often essential

Each manuscript should make satisfactory junctions (see 5414) with adjacent manuscripts and maps whose accuracy meets the requirements of the National Standards of Map Accuracy

After a map manuscript has been completely delineated, a compilation report is made This report is part of the Descriptive Report (see 72) and is a summation of the procedures followed during compilation

#### 5411 Accuracy of Delineation

The procedures completed prior to delineation of the map manuscript are correct within specified limits of accuracy The combined result of these requirements and procedures is a network of photogrammetric points, each located on the map manuscript within an accuracy 0.5 mm (0.02 inch) of correct geographic position The methods prescribed for the adjustment of the photographs to these points are such that there should be no appreciable loss of accuracy in the positions of the features transferred However, the transfer of details to the manuscript must be made carefully and accurately and in accordance with the delineation requirements of 5413

Cultural features shown on map manuscripts (except shoreline surveys) are completely inspected and are either approved or revised during field edit A careful inspection (except of shoreline surveys) of drainage, wooded areas, contours, and topographic features is made in representative areas, and these features are approved or revised Field-edit surveys are made to insure compliance with all requirements and to test the completeness and accuracy of the map manuscript

Field-edit surveys are made for the special purpose of testing the maps and making the necessary revisions and additions so that the maps are complete and comply with the National Standards of Map Accuracy and with the accuracy requirements of the Coast and Geodetic Survey

The horizontal accuracy of a map manuscript is tested by determining by a ground survey of higher order the geographic positions of well-defined points of detail appearing on the manuscript and by comparing those positions with positions of the same points as scaled from the manuscript. Well-defined points as described by the National Standards of Map Accuracy are those that are easily visible or recoverable on the ground, such as the following monuments (bench marks, property boundary monuments), intersections of roads or railroads (except those intersecting at acute angles), corners of large buildings or structures, and the centers of small buildings. No point shall be more than 0.075 inch from its true geographic position.

The following table is given to clarify the horizontal accuracy requirements

TABLE 51—*Tolerance equivalents*

Map Measurements	Equivalent Ground Distances (in feet) at Various Map Scales			
	10,000	12,000	20,000	24,000
0.15 mm -----	4.9	5.9	9.8	11.8
0.02 in = 1/50 in = 0.51 mm -----	16.7	20.1	33.5	40.2
0.04 in = 1/25 in = 1.02 mm -----	33.4	40.2	66.9	80.3
0.075 in = 3/40 in = 1.905 mm -----	62.5	75.0	125.0	150.0

#### 5412 Marking on Photographs

Topographic detail on office photographs is often not clear enough for accurate transfer directly to the manuscript. This may be caused by shadows, by lack of photographic contrast, or by poor definition. The last is often found on ratio prints and in the outer parts of the wing chambers of nine-lens photographs. It is then necessary to outline or to emphasize these obscure details in ink on the photographs prior to compilation. A water soluble ink should be used in a color that contrasts with the tone of the photograph. Weber Waterproof Pigment Ink (Cadmium Yellow or Cadmium Orange) and Johnston's Snow White are both excellent for this type of work.

Where features are being inked on the photographs, care should be taken not to mar the print. The inking of an area should be done on only one of the photographs so that there will still be unmarked photographic coverage. All inking should be done with the aid of a stereoscope, as a much clearer interpretation is possible when a three-dimensional model of the terrain is seen.

The ink emphasizing features on office photographs should not be removed after compilation but should be left for review purposes. If it is necessary to ink along-shore features, detail points, etc., on field photographs for compilation purposes, water soluble ink shall be used and then subsequently removed, leaving the field photographs as they were originally submitted by the field parties. This removal of ink is important because the same field photographs are eventually forwarded to the hydrographic parties to aid in recovery of photo-hydro stations. Water soluble ink can be easily removed from the photographs with a damp cloth.

*5413 Displacement of Map Features*

No map feature should be displaced from its true position except where this is necessitated by the inclusion of more important adjacent feature, and then the displacement shall be the minimum amount practicable

The minimum road widths specified for manuscripts are often greater than the true scale width of the road, the same is true of railroads. In other instances important features may have to be drawn somewhat oversize for clarity. Thus it becomes necessary to displace other features, as, for example, a building alongside a road. The photogrammetrist must use discretion in displacing features and in no case shall a well-defined map feature be displaced more than the accuracy tolerance for the particular manuscript scale.

General instructions including the order of preference in displacing features are stated in this section, but all circumstances which might arise cannot be foreseen and, as in other phases of the work, the good judgment of the photogrammetrist and his supervisor is essential.

Map manuscripts drawn in colored inks are quite readily read. However, the photogrammetrist must endeavor to make the drawings sufficiently neat and legible so that one-color reproductions of these manuscripts can be readily read and interpreted. Prior to final printing, copies of map manuscripts are required for field edit, for nautical chart corrections, and for other purposes. The photogrammetrist must constantly bear in mind the fact that these copies are reproduced in one color only. For example, parallel lines in different colored inks might be drawn too close together and still be legible on the manuscripts but illegible on the one-color reproductions where they might merge and appear as one line.

Clear reproduction requires a minimum spacing of approximately 0.3 mm between lines and symbols, otherwise the lines and symbols will merge in reproduction. Because many of the required features as they exist on the ground do not allow this tolerance in their delineation at the scale of the map manuscript, some must be displaced.

Control stations and shoreline features shall not be displaced. In general, planimetry shall not be displaced for hypsometry.

Bridges, viaducts, overpasses, underpasses, or other important cultural landmarks should not be displaced.

Except where necessary for mapping an important shoreline feature, the centerline of a road (classes 1 through 4) shall not be displaced to obtain the required road width. The centerline of dual highways may be displaced in order to delineate the required road width for that specific class (see 5441). The centerlines of roads of all classes, except trails, along section lines shall not be displaced.

Railroads shall not be displaced for roads (classes 5 through 8) or irrigation and drainage canals and ditches.

Cultural features represented by a line symbol, such as transmission lines and pipe lines, may be displaced for roads, railroads, canals, buildings, and drainage.

Drainage may be displaced for roads (classes 1 through 5), railroads, and contours. Vegetation may be eliminated where clarity demands it.

It is only possible to itemize the preferences in the displacement of map features in a general manner. Experience in compilation practices and the comparisons of map manuscripts with published maps will aid in answering the many questions that arise during the delineation of each map manuscript.

*5414 Delineation of Junctions*

Junctions of maps in any given project shall be completed in the photogrammetric office. When the manuscripts are forwarded to the Washington Office, copies will be made and furnished the photogrammetric office for perfecting the junctions with adjoining incomplete manuscripts. Should difficulty arise in making junctions, the original manuscripts can generally be returned on request. Copies of existing maps around the borders of each topographic or planimetric map project will be furnished and an attempt shall be made to join these maps. Where it is found to be impracticable to effect a junction at the neat line (project limits) with a map at a scale of 1:62,500 or larger which was published since about 1935, then a margin of detail shall be compiled 1.25 cm to 2.5 cm beyond the neat line of the new manuscript and the situation discussed in the Descriptive Report for the benefit of the Washington Office reviewer and the field editor. In general, exact junctions cannot be made with older maps, particularly those at scales of 1:62,500 or smaller and manuscripts need not be compiled over the neat line in case of junction differences. However, such junctions shall be examined carefully and where the differences indicate the probability of error in a new topographic or planimetric manuscript that fact shall be mentioned in the Descriptive Report and referred to the field-edit party for checking.

(For the junction of control between adjoining map manuscripts, surveys, or maps, see **4254** and **463**)

Where adjoining maps or map manuscripts differ in scale, a ratio projector can be used to transfer the junction details, or photostats can be made to the desired scale. Roads, railroads, or any feature represented with straight lines shall be transferred with sufficient length to ensure that no change in azimuth occurs at the junction.

All conflicts or differences encountered in making junctions between manuscripts within a project shall be adjusted or reconciled so far as practicable during compilation and before the map manuscripts are forwarded to the Washington Office. All information as to differences that are not adjusted or reconciled during the compilation of the map manuscript shall be shown on the discrepancy overlay (see **57**) and shall be fully described in the Descriptive Report (see **72**).

The notation "Joins T-" should always be placed just outside the neat limits of each map manuscript for each junction with Coast and Geodetic Survey maps. If there is no adjoining map, the notation "No contemporary survey" shall be made. Where a junction is made with surveys of other agencies a notation such as "Joins U S G S Quadrangle" shall be made. These notations shall be made in black permanent plastic ink.

*5415 Geographic Names*

A geographic names sheet (final name standard) is prepared in the Washington Office to furnish the photogrammetric offices with the names to be shown on the map manuscripts within each project. This information about names is the result of related research by the Washington Office and by the photogrammetric field parties. The photogrammetrist shall follow the names sheet as to spelling and placement. Although the geographic names are compiled and furnished by the Washington Office, they are not to be accepted without the possibility of error. Any apparent errors in spelling or placement found during compilation shall be noted on the discrepancy overlay (see **57**) and in the Descriptive Report (see **72**). In special cases the geographic names data may be sent directly to the photogrammetric office by the field party without transmittal to the Washington Office for review, if such review would delay the completion of an urgently needed manuscript. In such cases

all established names, the disputed names that the photogrammetrist confidently believes are correct, and the new names that are beyond dispute are inked on the manuscripts in black permanent plastic ink. The disputed names—those that are questioned as to spelling, placement, or acceptability—shall be penciled on the manuscripts.

It should be understood by each photogrammetrist that no other feature on a map is so easily verified by the map user as the geographic names. Errors in the spelling and the placement of names are an indication of carelessness which reflects on the accuracy of the map as a whole.

The placement of the geographic names takes precedence over all other names and notes and they shall be lettered after completion of the planimetric and topographic delineation and prior to the other names and notes.

### *5416 Names of Features*

The names of features, such as churches, universities, colleges, high schools, public buildings and other landmark buildings, roads, and important bridges, are obtained during field inspection and lettered directly on the field photographs.

The names, symbols, and notations for the following features shall be lettered directly on the map manuscript in black permanent plastic ink after the geographic names have been inked. If the details are congested, reference numbers may be used and the names and notations lettered in the margins or in a water area.

#### **A CHURCHES**

The names of only landmark churches and churches of particular historical significance or of other special significance shall be indicated in towns and cities (including urban areas), in rural areas the names of all churches shall be shown.

The religious denomination of a church shall not be indicated unless it is an absolutely essential part of the name. If a church has no name except the denominational name, the church shall be indicated by symbol only.

#### **B SCHOOLS**

The names of all schools located outside urban areas shall be shown. Where a school is in a village or town (outside an urban area), the village or town name shall not be included in the name of the school. The names of only high schools, colleges, and universities shall be indicated in urban areas. Grade schools shall not be named unless they are of landmark value.

#### **C BRIDGES**

Large bridges shall be identified by name—where they have names. Bridges less than 500 feet in length generally need not be named, except in the rare case where a small bridge has a name with special historical significance.

#### **D POST OFFICES**

All principal post offices shall be identified by name, city sub-stations and branch post offices shall not be indicated by name.



#### E RAILROAD STATIONS

Each railroad station shall be identified by name if the name differs from the name of the community in which it is located or if the station is situated at an appreciable distance from the community of the same name

#### F PUBLIC BUILDINGS

Proper names shall be shown in all areas for all the larger and more important public buildings (other than those already discussed above), such as courthouses, customhouses, large libraries, hospitals, and large institutional buildings, where these buildings have proper names. Proper names need not be given for fire stations and such smaller public buildings

#### G LANDMARK BUILDINGS

Landmark buildings are buildings that have map significance because of size, shape, or location, particularly those buildings that because of height are important to aeronautical charts either as obstructions or landmarks and those buildings visible from the water that because of location, shape, size or height are landmarks for navigators. As to its significance as a landmark, the size of a building is relative, in an open area a small building might have landmark value, whereas in a city with numerous large buildings only the larger or higher and more outstanding have landmark value

Proper names of landmark buildings shall generally be omitted. However, proper names shall be shown for particularly large or outstanding landmark buildings outside of urban areas. Within an urban area where many landmark buildings ordinarily are mapped, proper names shall be shown for only the few very outstanding ones which have special significance because of size or height, or which have some other special local significance

#### H OTHER BUILDINGS AND STRUCTURES

Proper names of commercial or industrial buildings and structures similar to buildings shall generally be omitted. However, where such a building is a particularly prominent landmark, its proper name shall be shown. Only a few such building names shall be shown in towns and cities (including urban areas). Individual structures of a group that is named shall not be further identified

#### I HISTORICAL RUINS

Ruins of historical importance shall be indicated by name followed by the word "Ruins"

#### J PRINCIPAL ROADS AND PRINCIPAL CITY ARTERIAL STREETS

In addition to federal and State route indications, well-known and important roads and principal city arterial streets or throughways shall be identified by name. These names, however, should be kept to a minimum and within congested urban areas only one or a few through streets shall be named

#### K MISCELLANEOUS FEATURES

Cemeteries, airports, parks, stadiums, fairgrounds, race tracks, golf courses, zoos, etc., shall generally be indicated by name. However, small cemeteries may be indicated by symbol only and the photogrammetrist may omit names of small and less important features wherever the map is otherwise congested

5417 *Placement of Lettering*

Descriptive notes and geographic names must not obscure map features, but shall be placed so as to indicate clearly and without ambiguity the features designated

Geographic names should be oriented on a map manuscript so as to be read from the south in an east-west direction, or when parallel to a meridian in a south-north direction (fig 5 4) Most names should be lettered in straight lines parallel to the parallels of latitude and, if practicable, should be placed east of the feature named and on the north side of highways, railroads, etc Where it is necessary, names may be curved to follow the general curvature of the feature, but should not be lettered on reverse curves Names of broad streams should be placed within the borders of the streams Names of features should be placed so as not to touch the alongshore detail

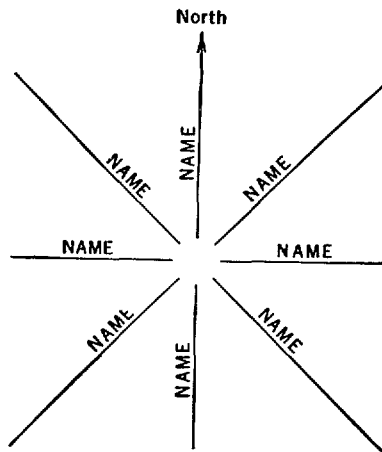
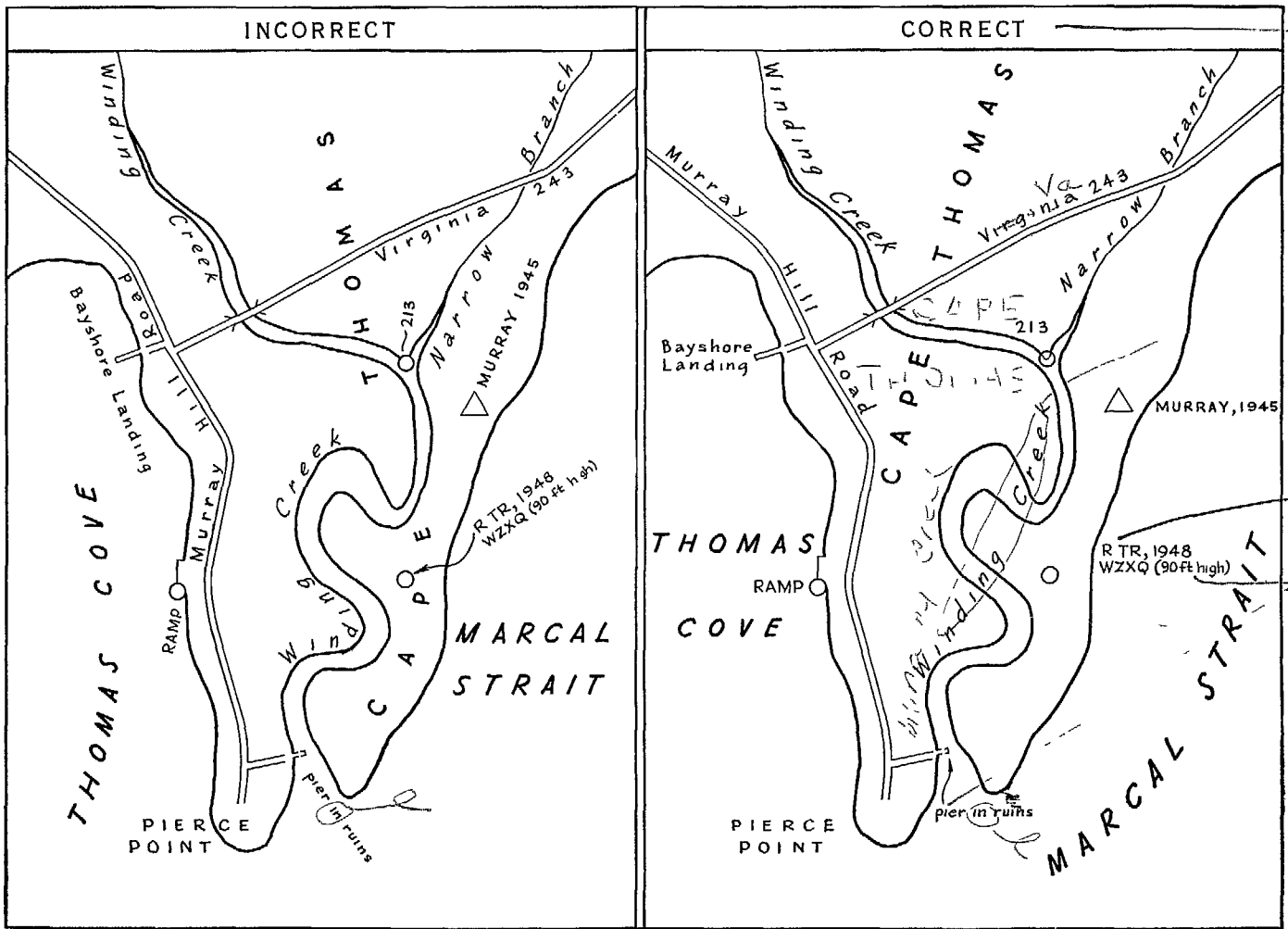

FIGURE 5 4—Orientation of lettering

Where possible, descriptive notes should be lettered in straight lines parallel to the parallels of latitude These notes should always be readable from the south Names, descriptive notes, and heights or elevations of features shall be placed as near the features to which they refer as practicable, the reproduction tolerance of 0.3 mm between lines and symbols being observed Where it is impracticable to place descriptive notes, etc, adjacent to the features they describe, the notes should be placed in the margin or in a water area and referenced to the feature by letter or number Arrows or leaders may be used occasionally but with caution—their frequent and careless use is particularly objectionable in alongshore areas because they confuse and obscure map features

Where a geographic feature has a considerable area, as an island or a bay, its name should preferably be placed in the approximate center of the area It should extend across the longest part of the feature Such names should never extend beyond the limits or even close to the limits of the named feature If a name is composed of several words, they should not be too widely separated in an attempt to extend them along the full length of the feature, instead, the full name should be repeated a second or even a third time

Periods are omitted after abbreviations on map manuscripts (See page 414)



TOPOGRAPHIC MANUAL PART II  
see pages and 11

FIGURE 5 5 — Placement of lettering

5418 *Compilation Report Notes*

The compilation section of the Descriptive Report (see 726 and 7261) supplements the map manuscript and contains information that cannot be shown graphically on the manuscript. While the photogrammetrist is delineating a map manuscript, he shall make notes, concurrently with the progress of the map, of items considered to be pertinent to a correct interpretation and review of the manuscript. This information should include the extent and the source of information supplementing the photographs, the difficulties encountered in the interpretation of the photographs, where detail is displaced to meet reproduction requirements (see 5413), information pertinent to the field edit and review of the manuscript, and information pertinent to the future use of the map (particularly in regard to its application to nautical charts) which is not evident on the manuscript. Examples are (a) Listing and discussion of source material other than the photographs and field inspection data, (b) List of places where the field data were insufficient to ensure correct interpretation of the photographs, (c) Inadequate photograph coverage or quality (d) Specific items requiring completion during the field edit (e) Specific items requiring investigation by the hydrographic party, (f) The date of shoreline location if different from the date of the photographs, (g) Items requiring immediate application to the nautical or aeronautical charts. If such notes are not made during delineation, the compilation report is reduced to a stereotyped form because of the lack of information. Memory cannot be relied on!

All notes and calculations shall be filed according to 1543

542 **DELINEATION OF ALONGSHORE AREAS**

The planimetry of alongshore areas is delineated with the same accuracy on all three types of map manuscripts. On shoreline manuscripts symbols are more generally used than legends in delineating alongshore features because these manuscripts are not redrafted. Planimetric and topographic manuscripts are redrafted, thus permitting a more general use of legends.

Field inspection requirements state that alongshore areas (5421) shall be inspected and the details clarified in the field by notes on the photographs—the completeness depending upon the circumstances and the type of shoreline. The purpose of the field inspection is to identify for the office photogrammetrist the shoreline or mean high-water line, the low-water line (where practicable), and to clarify the physical and cultural alongshore features that cannot be correctly interpreted from an office examination of the photographs alone. The field inspection information is inked on the field photographs by symbols and legends (see figs 5 21 through 5 47). Each mark on a field photograph is the result of an actual observation in the field.

It is often preferable to compile the shoreline and alongshore features directly from the field photographs. This can be done if the detail points needed to control delineation of the alongshore area are transferred from the office to the field photographs. All symbols and marks made in the office on the field photographs shall be in washable ink and shall be removed upon completion of the photogrammetric office review of the manuscript.

5421 *Shoreline (Mean High-Water Line)*

The line delineated on planimetric, shoreline, and topographic manuscripts as the *shoreline* is the mean high-water line ~~the~~ the line of intersection of the mean high-water

plane with the ground) except in areas of marsh grass, mangrove, cypress, or other similar marine vegetation, where the shoreline (mean high water) is often obscured and cannot be mapped. In these areas an *apparent shoreline* is mapped at the point where the line of vegetation is a definite line above mean high water. As this is the line that appears to the navigator as the shoreline, it is delineated as such and is located in lieu of actual mean high-water line. In nearly all cases there should be enough information to delineate this line. The unsurveyed or approximate mean high-water line symbol shall not be used to represent this apparent shoreline. The photogrammetrist should remember that the apparent shoreline represents a line of vegetation and not a fixed line on the ground. Therefore an approximation is acceptable where grass limits are rather indefinite. The scattered-grass-in-water symbol shall be used where such vegetation exists offshore from the selected apparent line referred to above. Sections of shoreline—particularly shoreline on fast land—which cannot be delineated with reasonable accuracy because they are obscured by shadows, or for other reasons, shall be approximately delineated with the dashed-line symbol specified for unsurveyed (approximate) shoreline.

The following methods of marking the field photographs and of furnishing the essential data (see figs 522 and 523) are used by the field personnel to aid the office photogrammetrist in the delineation of the shoreline.

(a) Where the shoreline is clear on the photographs and can be delineated *with certainty* from the photographs alone the shoreline will occasionally be confirmed by a short dash in red ink.

(b) Where the shoreline could be one of several lines that are faintly visible on the photographs, the correct shoreline will be identified by short dashes in red ink at necessary intervals.

(c) Where the shoreline is very irregular and bears no consistent relationship to a visible line on the photographs, the correct position of the shoreline will be indicated at frequent intervals by a broken line in red ink. In this case the frequency of the dashes on the field photographs will be greater than in (a) and (b). (The line is broken in order to allow stereoscopic inspection of the shoreline.)

(d) Where the shoreline is not visible on the photographs because of overhanging trees or shadows from trees it is located at intervals by measurements from the nearest identifiable points of detail. Short dashes in red ink delineate the shoreline at the measured points. These points are close enough together to ensure that the shoreline is correct within 0.5 mm. In many instances the overhang of trees is so slight that with care the field inspector can estimate the shoreline without reference measurements and indicate it on the photographs within 0.5 mm of its correct position.

(e) Where the shoreline is not visible on the photographs for reasons other than those stated in (d) and cannot be located by reference measurements, it is located by planetable traverse or sextant fixes.

Short planetable traverses may be plotted in water areas on the photographs or on separate low-shrinkage sheeting. The scale of the work will be indicated, and all identifiable points used to tie the traverse to a photograph will be properly cross-referenced.

Sextant fixes (see 55), though less desirable, may be substituted for planetable traverse. These fixes will be spaced at adequate intervals to permit the accurate delineation of the shoreline. The well-defined points of detail used as objects for the three-point fixes will be properly identified and cross-referenced on the photographs.

(f) Where the shoreline has changed considerably since the date of the photograph, one of the methods described in (d) and (e) will be used to determine its location. The date of this location will be given.

(g) In marsh, mangrove, cypress, or other similar areas the mean high-water line is generally obscured by vegetation. A broken line of short and long dashes on the field photographs will indicate the apparent shoreline, and ticks will indicate where fast land begins. These dashes will be in red ink. (See 5423B.)

(h) Where a detailed field inspection of the shoreline is impossible and the mean high water line cannot be accurately determined by photographic interpretation, an approximate mean high-water line (unsurveyed) will be marked on the photographs by a dashed line in red ink and indicated with the legend "approx MHWL" in inclined letters. The symbol and the legend to indicate approximate mean

high-water line will not be used to indicate apparent shoreline. If, however, a mistake was made during the field inspection and the approximate mean high-water symbol was used to indicate apparent shoreline, the office photogrammetrist shall ensure that the correct symbol—apparent shoreline—is used on the map manuscript

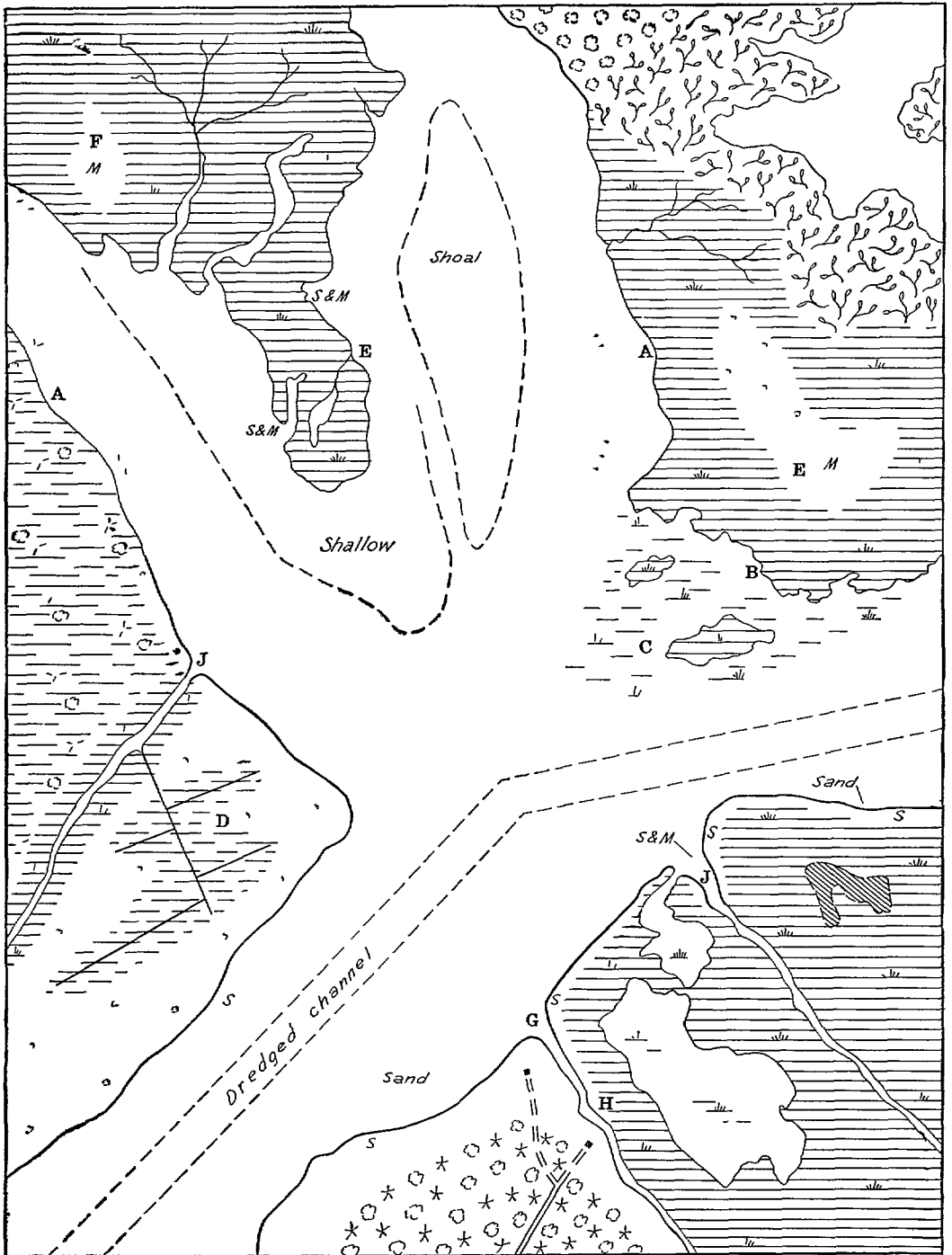

FIGURE 5 6a —Alongshore physical features on a shoreline manuscript

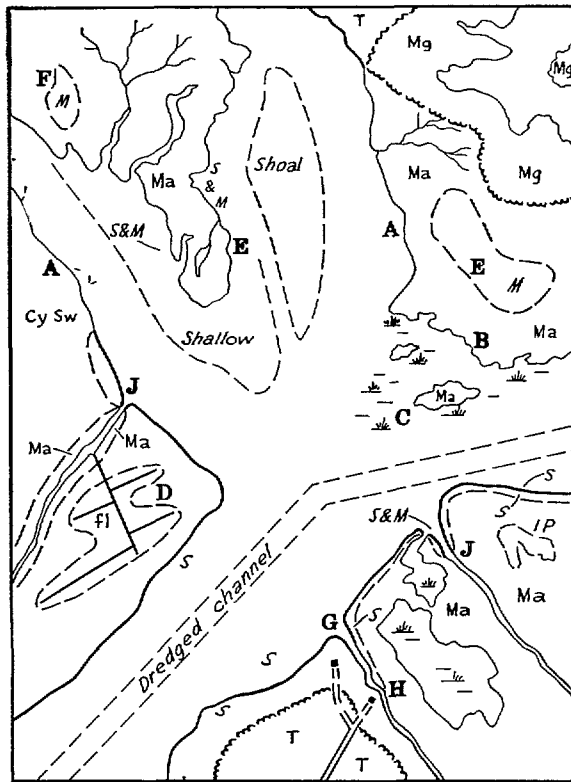

FIGURE 5 6b—Alongshore physical features on a planimetric or topographic manuscript

Shoreline on a map manuscript shall normally be a solid black line 0 012 inch wide. For rocky coasts where the shoreline is intricate, a solid black line 0 010 inch wide shall be used so that the characteristic shapes of small points and indentations can be delineated. Along relatively narrow double-line streams and canals the mean high-water line on fast land shall be a solid black line 0 008 inch wide in order to avoid having the stream appear too heavy. Approximate mean high-water line shall be a dashed black line 0 012 inch wide. Apparent shoreline shall be a solid line 0 006 inch wide. The outlines of cultural features extending into the water along the waterfront, such as piers, are delineated as a part of the shoreline in solid black, light enough in weight to contrast with the adjoining shoreline and to show the small details of the features. (See figs 5 22, 5 23, 5 27, and 5 28.)

The change in line weight from the outline of cultural features or from apparent shoreline to shoreline on fast ground (MHW) must always be abrupt. (See figs 5 6a, b and 5 22.)

#### 5422 *Low-Water Line*

The low-water line (designated as mean low-water line on the East Coast and as mean lower low water on the West Coast) shall be determined by office interpretation only when the aerial photographs have been taken at or near the time of low water.

The low-water line will be identified by field inspection under the following circumstances:

(a) Where the low-water line is not likely to be reached by a hydrographic party, as on an exposed coast or inshore from barrier reefs, the field inspector will make a special effort to sketch the approximate low-water line on the photographs

(b) Where the foreshore is steep and narrow and the approximate position of the low-water line can be indicated during the regular course of the shoreline inspection

(c) Elsewhere, the low-water line will be indicated in areas where the field inspector has an opportunity to examine it at or near the time of mean low water without appreciable delay to other phases of his work

If an underwater line is clearly visible on the photographs, as the edge of a reef or a mud bank, the field inspector will state whether this is the low-water line, a shoal line, or a reef line

The field inspector's report will, in addition, state in what general areas the low-water line has been identified exactly and in what general areas it has been identified approximately. An exact low-water line will be indicated on the photographs by a line of alternate dashes and dots in green ink. An approximate low-water line will be indicated by a dotted line in green ink.

On map manuscripts, only the dotted line is used as a symbol and is inked in permanent black ink. (See fig 5 22.) However, if a distinction is considered necessary on the map manuscript, an approximate low-water line shall be indicated by adding the legend "approx" in inclined letters to the symbol.

### 5423 *Alongshore Physical Features*

The character of the foreshore area (between the mean high-water line and the mean low-water line) shall generally be indicated on the map manuscript by symbol or legend (see fig 5 22). Symbolization shall be used where it is necessary for clarity.

The following physical features are mainly found in alongshore areas and for that reason are discussed here. Rocks, reefs, and ledges are discussed in 5424. Other physical features are discussed in subject 543.

#### A BLUFFS, CLIFFS, CREVICES, AND SCARPS

Bluffs, cliffs, crevices, and scarps are comparatively permanent features that are easily distinguished from their surrounding features. Because they are valuable to the hydrographer and to the navigator as landmarks, they will be indicated by field inspection and shown on map manuscripts. These features shall be delineated by their appropriate symbols on planimetric and shoreline manuscripts. Their symbolization by hachures (see fig 5 8) does not give the elevation above the datum plane, but only indicates the relative heights or the steepness of grade.

These features will generally be symbolized on topographic manuscripts by contours. Other symbolization shall be used only where the feature is not adequately portrayed by the contours.

#### B MARINE VEGETATION

Where marsh grass grows in water with a definite edge visible above mean high water, field inspection will indicate the definite marsh grass edge to be delineated as the apparent shoreline (see fig 5 6aA). An apparent shoreline will also be indicated where the marsh edge is less definite and is fronted by sparse grass in water (see fig 5 6aB).



Occasionally an entire area of marsh grass is flooded up to the fast land, with only scattered tops showing at mean high water—too scattered or thin to be enclosed within an apparent shoreline. In such cases the field inspector will indicate the shoreline to be delineated and the outer limits of the scattered marsh grass that are to be mapped.

All scattered grass in water outside a definite or an apparent shoreline shall be indicated by symbol on map manuscripts in accordance with figure 5.6aC in black permanent plastic ink. This symbol is open in character but shall be drafted to show the limits of the grass accurately.

Growing kelp is generally associated with rocky bottom and for that reason is important to the navigator and the hydrographer as its presence is an indication of danger. When practicable, kelp will be identified and its limits defined on the field photographs. On map manuscripts small patches are symbolized, extensive beds are outlined in black permanent plastic ink and are identified by appropriate legend in inclined letters.

### C MARSH, MANGROVE, AND OTHER SWAMP AREAS

On field photographs where correct identification demands it, these features will be indicated by legend, and their limits will be outlined.

The shoreline of marsh, mangrove, and similar areas is delineated as described in 5421.

There are places where low ground areas (not swamp) are important terrain features from a geological viewpoint and should be mapped with the special symbol in fig. 5.36. However, it is a rare case where such areas are not adequately shown when mapped as swamp. To eliminate indiscriminate use and wasted field and office effort spent in applying this distinct classification, it will be used only when called for by the project instructions.

All legends pertaining to these features shall be in vertical letters where the feature is above mean high water and shall be in inclined letters where the feature is below mean high water.

#### a Planimetric and Topographic Manuscripts

The inshore limits of marsh, swamp, and mangrove shall be indicated by a broken line, except where the adjoining features show these limits accurately and completely. This line and the necessary legend shall be inked in blue permanent plastic ink. Symbols may be used only where the legend will not sufficiently show the condition or where the area is too small to justify using a legend; these symbols shall be in black ink.

#### b Shoreline Manuscripts

These features shall be delineated in black ink. Symbols shall be used in all instances with the exception, that in large areas of marsh, swamp, or mangrove the limits may be symbolized, and the central portion indicated by a legend without the symbol.

### D SAND, GRAVEL, SAND AND GRAVEL, MUD, AND BOULDERS

These features will be identified as necessary during the field inspection and will be indicated by legend with their limits outlined by a broken line on the field photographs.

Changes in character of the shore less than 40 mm in length on the map manuscripts may be disregarded

These features shall be indicated by legend in black permanent plastic ink and in the foreshore area on all three types of map manuscripts. Symbols may be used in short stretches where a legend will not sufficiently show the condition or where the area is too small to justify the use of a legend. Generally stretches of sand, gravel, sand and gravel, or boulders 100 mm or less in length on the map manuscripts shall be symbolized, otherwise they shall be outlined with a dotted line and identified by legend (see figs 5 22 and 5 23). Wherever shown, areas of mud shall be outlined with a dotted line and indicated by legend. The outline may be omitted where the area or parts of the area are defined by another map feature. (See fig 5 6E and F)

#### E SHOALS, CHANNELS, AND BREAKERS

\* A shoal is a detached non-coral or non-rocky area which may shift position or change shape and which is a menace to surface navigation

A channel is the deeper part of a body of water that affords the best passage for navigation

Because photographic interpretation of shoals and channels can be very inaccurate, field inspection will be made whenever practicable to furnish the following information

- (a) Character of discolorations in the water areas on photographs and whether these discolorations are caused by shoals, channels, or mud-laden currents
- (b) Outlines of the features to be delineated
- (c) Where practicable the low-water line for areas that bare at low water
- (d) Heights of shoals referenced to the sounding datum

Shoals and channels indicating abrupt changes in depth and possible dangers are guides to the hydrographer, therefore, their delineation is important. But shoal indications on photographs are deceptive—mud-laden water often resembles shoal water. The nautical charts should be consulted and indications on photographs that might be interpreted as shoals, channels, reef lines, etc., should not be delineated where soundings prove their non-existence, nor should they be shown where soundings indicate gently sloping bottom. These comparisons should be made whether or not field inspection has been made of the pertinent areas.

Shoals and channels are outlined on map manuscripts by a broken line enclosing the appropriate legend which is lettered in inclined letters. (See fig 5 6)

Breakers and surf immediately along the shore are not delineated on map manuscripts. Only those breakers are shown that indicate a danger to navigation. Field inspection will generally identify such breakers; however, they may be identified from a close study of office photographs (see 5231D). Breakers are symbolized by enclosing the feature with a broken line and identifying it with the legend "Breakers" in inclined letters. (See fig 5 23)

Shoals, channels, and breakers shall be delineated on all three types of manuscripts in black permanent plastic ink

#### F TIDAL DRAINAGE

Marsh, swamp, and mangrove areas along the shore are generally traversed by a network of tidal drainage, such as sloughs. The course of this drainage is rather permanent in location and is of great assistance to the hydrographer and others traversing these areas

These areas are generally clearly defined on the aerial photographs and require few field inspection notes for interpretation of the apparent shoreline

Tidal drainage shall be delineated in black permanent plastic ink as completely as the scale of the map manuscript will permit This drainage should be double-lined where the width of the streams on the map manuscript is 0.5 mm or greater, widths less than 0.5 mm shall be single-lined

#### 5424 Rocks, Reefs, and Ledges

##### A GENERAL DEFINITIONS

The delineation of rocks, reefs, and ledges is one of the most important phases in the compilation of a map manuscript because of the importance of these features to navigation To delineate them properly, one must know the vertical datums to which water depths and heights of rocks are referred and the three general classifications of rocks, as used by the Coast and Geodetic Survey (See fig 57)

The planes of reference, some of which are also sounding datums, are as follows

(a) Mean low water (MLW) is a plane of reference, and is the sounding datum along the Atlantic and Gulf Coasts of the United States

(b) Mean lower low water (MLLW) is a plane of reference and is the sounding datum along the Pacific Coast of the United States, for Alaska, and for islands in the Pacific Ocean

(c) Mean high water (MHW) is a plane of reference used everywhere for the elevations of lighthouses, landmarks, rocks above high water, and other alongshore features on nautical charts

(d) Mean sea level is the plane of reference for topographic mapping, except for certain features of importance to navigation that are referred to MHW, such as aids to navigation, landmarks for charts, and small islands

With reference to (c) and (d), for the use of the mariner, nautical charts must show the elevations of prominent alongshore objects referred to mean high water For this reason, field parties are instructed to determine the elevations of lighthouses, landmarks, prominent pinnacle rocks, and islands above mean high water, and the heights of the structures above the ground In order that these elevations shall not be confused with mean sea level elevations, all the elevations referred to mean high water shall be shown on the photographs and on the manuscripts in parentheses, and the heights of landmarks above ground shall be indicated on both photographs and manuscripts, as "ht = "

A *ledge* is a rock formation connected with and fringing the shore The area that uncovers is represented on manuscripts by symbol and legend A *reef* is a coral elevation, or a detached rocky elevation that is dangerous to surface navigation and may or may not uncover at the sounding datum A rocky reef is detached from the shore but a coral reef may or may not be connected with the shore

The conventional definitions of the three types of rocks (including those protruding from reefs and ledges) are as follows

(a) Bare rocks are those extending above the plane of mean high water

(b) Rocks awash are those exposed at any stage of the tide between mean high water and the sounding datum or that are exactly awash at these planes

(c) Sunken rocks are those covered at the sounding datum

These conventional definitions have been modified in order that the rocks may be adequately portrayed on the final map as they would probably appear to the navigator

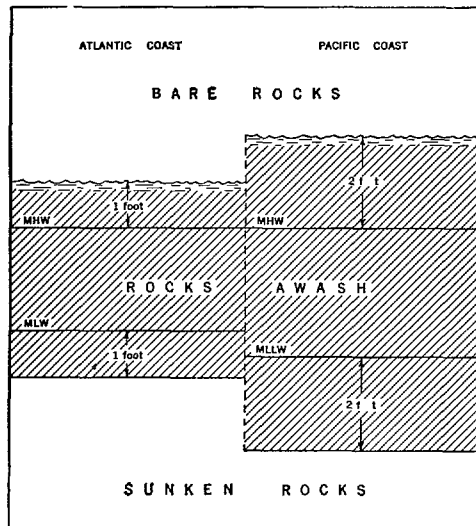

FIGURE 57—Planes of reference for rocks

(a) Bare rocks are rocks with elevations of 1 foot or more above mean high water on the Atlantic Coast and 2 feet or more on the Pacific Coast

(b) Rocks awash are rocks with their summits between 1 foot above mean high water and 1 foot below the sounding datum on the Atlantic Coast. On the Pacific Coast these limitations are 2 feet

(c) Sunken rocks are rocks with their summits more than 1 foot below the sounding datum on the Atlantic Coast and more than 2 feet below the sounding datum on the Pacific Coast

#### B FIELD INSPECTION NOTES

As rocks are difficult to detect and interpret on aerial photographs, the office photogrammetrist may expect rather detailed notes on the field photographs to aid in their delineation, unless the project instructions specifically state that this work shall be done by the hydrographic party.

Where these features are to be mapped by the photogrammetric survey and the field inspector has failed to give the elevation of a rock that is of importance to nautical charts, this shall be called to the attention of the hydrographic party in the "Notes for the Hydrographic Party" section of the Descriptive Report (see 7261).

The elevations of rocks awash, and rocks and islets above high water are primarily for nautical charts and need to be determined *only where they are of importance for charting*. Elevations will be determined for off-lying rocks, for those at the outer edges of clusters, and, generally, for those that lie along the edges of navigable channels and waterways. The foregoing statement applies both to rocks awash and to rocks and small islands above mean high water. Elevations are generally not furnished for rocks lying within the foreshore, lying close inshore along a rock-studded coast, or lying inside large groups of rocks.

In a topographic map project the elevations of islands are required as part of the hypsometry. In *addition* to the needs for nautical charts, elevations shall be determined for all islands that are between  $\frac{1}{2}$  and 1 contour interval above mean sea level, except that only an occasional elevation is required for small islands in groups. These will then be shown as spot elevations on the topographic maps. These elevations will be noted by the field inspector and shown on the manuscript by the photogrammetrist as elevations above mean

high water *They will be converted to elevations above mean sea level during the Washington Office review and processing*

Where these features adjoin the shore with little or no navigable water between them and the shore, and where they exist in groups, the field inspection will generally show the height, location, and character of the rocks in the following instances

(a) Along a rock-studded coast, the highest and the farthest offshore rocks will be identified and described

(b) Within a group of rocks or a rocky area the highest and those near the outermost limits of the area will be identified and described

(c) In a foul area of rocks, reefs and ledges, only the most prominent rocks will be identified and described or the entire area may be outlined. In the latter case descriptive notes of the general character of the area and how it is to be delineated will be furnished. The photogrammetrist will then identify the most prominent rocks and delineate the areas in accordance with field instructions

Where the field inspector uses a boat, he will endeavor to identify and furnish the following information for detached rocks and ledges of navigational importance that can be distinguished on the photographs and that he can reach with the boat equipment at his disposal

(a) The character of the feature with reference to some plane of reference (i. e., whether any of it is bare at mean high water or whether it is awash or sunken)

(b) The elevations with reference to some plane of reference of those features of most navigational importance

(c) The delineation—if the feature is large enough—of the high-water line if it bares and the delineation of the low-water line if the feature has a very gently sloping shore as a ledge

(d) Where practicable the low-water line if the feature is covered at high water but bare at low water

(e) The character of the feature, as reef or ledge

Where it is feasible with the boat equipment at the disposal of the field inspection party, detached rocks above MHW not distinguishable on the photographs will be located and described by field inspection, some detached rocks below MHW may also be located, if convenient (Detached rocks above MHW that are distant from shore and all detached rocks below MHW may be left for the attention of the hydrographic party if that is more convenient and economical.) They may be located by planetable, or by sextant

Sunken rocks will rarely be identified by field inspection because such features are seldom seen and the field party does not have the facilities for locating them

### C RULES OF APPLICATION

All rocks, reefs, and ledges shall be delineated in black permanent plastic ink. Inclined lettering shall be used for names and legends accompanying such features that are below mean high water. Vertical lettering shall be used for those above mean high water.

All rocks of individual importance that are located or identified by the field party or those that are identified in the office, using the same criteria, shall be individually symbolized. One symbol should be used for a cluster of closely grouped rocks awash.

Elevations of bare rocks must be referenced to mean high water, unless they are high enough and large enough to be contoured, in which case on topographic maps they are referenced to mean sea level. The actual shape of a bare rock shall be shown if it is more than 0.5 mm in its longest dimension on the map manuscript, otherwise it should be indicated by a dot.

Elevations of rocks awash must be referenced to mean low water or mean lower low water. They shall be symbolized by three crossed lines 2 mm in length (0.08 inch) at angles of 60°, one line of which is parallel to the lines of latitude.

Sunken rocks are those that are covered at all stages of the tide (see fig 57) They shall be symbolized by a cross of lines 2 mm in length (0.08 inch), one of which is parallel to the lines of latitude

The abbreviation "Rk" may be appended where there is risk of overlooking or mistaking the symbol

All elevations of rocks, reefs, and ledges above any datum shall be given in feet to the nearest whole foot

The elevation of a bare rock or small island above mean high water shall be shown near the feature in inclined figures in parentheses, as (5) Rocks awash at mean high water are accompanied by the note '*awash MHW*' The heights of those awash between the sounding datum and mean high water shall be shown in inclined figures in parentheses and underscored, as (5) Those awash at the sounding datum are accompanied by the note "*awash at MLW*" or "*awash at MLLW*" Elevations of rocks and small islands determined by stereophotogrammetric methods shall be in brackets as [5] or [5], instead of parentheses to distinguish these elevations from those determined by ground methods, stereophotogrammetric elevations of such features will be referred to the same datum as features determined by ground methods

Depths of sunken rocks are seldom available Where a depth has been determined, the depth referred to mean low water or mean lower low water should be noted on the map manuscript near the rock

Foul areas, whether detached or alongshore, are symbolized by a broken line enclosing the legend "Foul" and such rocks as have been accurately located in position Foul areas of wreckage, debris, or other objects shall likewise be enclosed with a broken line within which is an appropriate legend, such as "Hulks" or "Foundation remains"

Rock ledges and coral reefs that uncover at the sounding datum will be completely symbolized on all types of maps, except that where the ledge or reef area is large only the fringing limits need be symbolized with an appropriate legend in the unsymbolized area Where these limits are below the sounding datum and are furnished by field inspection or can be seen on the photographs they shall be outlined by a broken line

#### 5425 *Alongshore Cultural Features*

Certain cultural features occur only in alongshore areas Others have a special significance and specific delineation requirements where they occur in alongshore areas (see **5425B** and **5425C**) (For inshore cultural features, see **544**)

The field inspector outlines only those alongshore cultural features that require clarification and those whose shape has changed since the photographs were taken The field inspector will identify a cultural feature by appropriate legend, if there is probable doubt as to its interpretation, and by name, when it is required

On all map manuscripts, alongshore cultural features are delineated in black permanent plastic ink

#### A BREAKWATERS AND JETTIES

All breakwaters and jetties are to be shown where the scale permits If visible on the photographs or outlined by the field inspection, the underwater portions of these features shall also be delineated Breakwaters are structures to break the force of waves, jetties extend into the water, usually normal to the shore, to restrain or direct currents

On all map manuscripts breakwaters and jetties are double lines if their widths are 0.5 mm or greater, otherwise they are delineated by a single line 0.010 inch wide. Submerged parts, if they are known, are delineated by a broken line. (See fig. 5.28.)

Legends for submerged breakwaters and jetties shall be lettered in inclined letters, vertical letters shall be used for those not submerged.

#### B BRIDGES OVER NAVIGABLE WATER

Bridge data for all bridges over navigable water in each mapping project are furnished by the field inspection parties. The actual measurements made and the data actually collected in the field are recorded on the field photographs. This information consists of

- (a) Name of the bridge—if it has one
- (b) Character of each bridge, such as fixed or draw, and, if draw, the type
- (c) Horizontal clearance
- (d) Vertical clearance
- (e) Time of day
- (f) Date
- (g) Local information as may be required to evaluate the vertical clearance

The field party will submit a tabular report of the bridges within the limits of each map. This is a part of the field inspection report.

The field measurements shall not be evaluated in the photogrammetric office. However, field corrections referring the vertical clearances to the plane of mean high water shall be verified.

The name of the bridge (see **5416C**), the character and/or type, and the horizontal and vertical clearances shall be lettered on the map manuscript. The measurements to be used are the field data, corrected to the appropriate plane of reference.

Bridges over navigable waters shall be drawn to scale on map manuscripts where space permits, otherwise they shall be symbolized according to the type of bridge (see fig. 5.29). Where the scale permits, all the bridge foundation piers within the water areas shall be located and delineated. This also includes main piers on land of important bridges, as the San Francisco Bay Bridge, where they can be shown without crowding other features. Fenders and piling at the draw spans shall also be shown.

#### C BUILDINGS

The general delineation requirements for buildings are discussed in **5446**, however, specific requirements for buildings for nautical charts are repeated here for the convenience of the photogrammetrist. These buildings shall be classified, delineated, and named in accordance with **5446**.

In urban areas all buildings shall be delineated in the narrow zone immediately along the waterfront for nautical chart purposes, the only exception being that when the waterfront buildings are congested the minor ones such as garages and small outbuildings shall be omitted. All buildings on piers shall be delineated. Generally, this zone need extend only from the shore back to the nearest street, railroad, or other natural limiting line. The depth of this zone of waterfront buildings need never be more than 200 to 300 meters. Outside urban areas the building requirements for topographic and planimetric maps are practically identical with those for nautical charts, with this exception—a small isolated building along the shore shall be shown regardless of the fact that the requirements for topographic and planimetric maps may permit its omission.

All buildings on piers shall be delineated

Vertical lettering shall be used for all legends referring to buildings

When planimetric or shoreline manuscripts are being made concurrently with topographic maps of the same area, the alongshore buildings in urban areas may be omitted from the topographic maps

#### D CANALS AND DITCHES

All navigation canals and their locks will be indicated by field inspection and shall be delineated (see fig 5 25) Main drainage and irrigation canals shall also be delineated The extent to which feeder ditches and laterals are mapped will depend on the density of cultural features in the area Generally only canals and main ditches shall be shown along roads The field inspector will identify the canals and main line ditches in a system and indicate the general character of the others He will state whether they are for irrigation or drainage and whether they are generally perennial or intermittent When field inspection has not been made prior to delineation, the photogrammetrist shall delineate the canals and the main ditches and those serving as important landmarks in areas of very sparse culture Where an area has a complex system of canals and ditches, the entire area shall be examined by the supervisor prior to the delineation and a policy determined regarding the omission of the small feeders and the laterals

Where the scale of a map manuscript is large enough, canal locks will be delineated as they exist Where the scale is not large enough and canal locks must be symbolized, the symbol indicating the upper and lower gates will be correctly positioned and the legend "Lks" will be used (See fig 5 29)

In marshy areas where the purpose of canals or ditches is to drain water, all shall be shown as perennial In arid areas where the purpose of canals or ditches is to supply water, all shall be shown as perennial

No distinction by symbol shall be made between canals and ditches, any distinction between them shall be made by legend (See fig 5 25)

Inclined lettering shall be used for all legends referring to canals and ditches

#### E DAMS

The field party will identify dams on the field photographs and indicate the type—whether earthen or masonry—and give the specific name of the dam, if any

The actual shapes of dams and their spillways shall be delineated if the scale of the map manuscript permits On all map manuscripts, masonry dams shall be drafted with radiating lines following the general fall of the dams Earthen dams shall be delineated by hachures on both planimetric and shoreline manuscripts and by contours on topographic manuscripts

Dams shall be symbolized (see fig 5 29) if their actual shapes cannot be delineated

#### F DOLPHINS, PILING, SUBMERGED PILING, FENDERS, STUMPS, AND SNAGS

Dolphins (clusters of piling), piling, submerged piling, etc, are identified on field photographs during field inspection These features, with the exception of fenders, shall be symbolized on map manuscripts in accordance with figures 5 27 and 5 28 and shall be indicated by appropriate legends Fender structures shall be delineated to scale when the scale of the map manuscript is large enough

Legends pertaining to dolphins, piling, and fenders shall be in vertical letters Inclined lettering shall be used for legends for submerged piling, stumps, and snags



**G DRY DOCKS, FLOATING DOCKS, AND PATENT SLIPS (MARINE RAILWAYS)**

Dry docks, floating docks, and patent slips are identified on field photographs during field inspection. They shall be delineated in their actual shape on all map manuscripts if the scale is large enough, otherwise they shall be symbolized according to figure 5 27. A legend may be used if there is any question as to identity. This legend shall be in inclined letters for floating docks and in vertical letters for dry docks and for patent slips.

**II FERRY SLIPS**

The field inspector will identify ferry slips and indicate the route names at each terminus.

The actual shapes of ferry slips shall be delineated if the scale permits, otherwise they shall be symbolized (fig 5 29). The route names shall be lettered in vertical letters at each terminus, as 'Fy-Sandy Point to Matapeake''

**I FISH STAKES, FISH TRAPS, AND DUCK BLINDS**

Fish stakes, fish traps, and duck blinds that are fairly permanent or are dangerous to navigation will be indicated on the field photographs. Fish trap areas marked only by buoys shall not be shown.

If the scale of the map manuscript is large enough, the actual shapes of fish traps and duck blinds shall be drafted. Where symbols are used, the sides of the symbols should never be drafted smaller than 0.6 mm (0.025 inch). Fish stakes shall always be symbolized. (See fig 5 28.)

Vertical lettering shall be used for any legends pertaining to these features.

**J LEVEES, DIKES, AND SPOIL BANKS**

All levees, dikes, and spoil banks will be identified on the field photographs during field inspection.

Levees, dikes, and spoil banks shall be represented by hachures on planimetric and shoreline manuscripts. (See 5432F.) On topographic manuscripts these features shall be delineated in accordance with 5432D. Hachures shall not be used to outline spoil areas that do not have distinct banks, such areas may be outlined with the symbol for area enclosures (fig 5 40) if their limits are not indicated by other features such as the shoreline, marsh, etc.

**K OBSTRUCTIONS**

Obstructions of any kind not specifically mentioned in this manual shall be symbolized in outline (with a broken line) on all manuscripts. They shall be accompanied by a note as to the nature of the obstruction if it is known, otherwise they shall be accompanied by the legend "Obstr" (See fig 5 23.)

**L OVERHEAD AND SUBMERGED CABLES AND SUBMERGED PIPE LINES**

During field inspection, the vertical clearances of all cables, wires, or other suspended objects over navigable waters will be measured to an estimated mean high water. The measurements will be made from the lowest point of the catenary to the water surface. Where this point is not over the center of the navigable channel, a second measurement

will be made from the water surface to the cable at the channel centerline. The temperature will also be given. Generally the towers supporting overhead transmission, telephone, telegraph, or other cables over navigable waters will be identified on the field photographs (See 5444)

Clearance measurements are not required over narrow or shallow streams which are navigable only by skiffs or small boats.

The information, as lettered on the field photographs, is transferred to the map manuscripts, or tabulated in the Descriptive Report, and the positions of the towers are symbolized where identified (see fig 5 30). The field measurements need not be evaluated in the photogrammetric office.

Where poles are used to support cables or wires over infrequently used and unimportant navigable waterways, the poles are generally not located as stations. The cables are delineated as shown in figure 5 30.

The shore ends of submerged cables and submerged pipe lines are identified or located on the field photographs and shall be indicated on map manuscripts and accompanied by appropriate legends (See fig 5 30).

Vertical lettering shall be used for legends for overhead cables or wires. Inclined lettering shall be used for legends for submerged cables and submerged pipe lines.

#### M PIERS AND WHARVES

Piers are structures that extend from shore into navigable water to be used for landings. Wharves are structures built along the shore whose faces generally parallel the shore, so that vessels may lie alongside to receive or discharge cargo, passengers, etc. These terms are *not* to be confused with docks which are waterways between two piers or projecting wharves or are cuts into the land for the reception of ships.

Dilapidated piers and the underwater remains where piers have been removed will be drawn in complete outline on field inspection photographs. Floats and barges alongside piers or wharves will be carefully noted. The numbers or names of all important piers and wharves will be given.

The outlines of piers and wharves extending off the shore are delineated as a part of the shoreline in a solid line, light enough in weight to contrast with the adjoining shoreline and to show the small details of the features (See fig 5 27).

All buildings on piers shall be delineated.

Vertical lettering shall be used for all piers and wharves.

The names and numbers of all important piers and wharves shall be shown on all manuscripts.

#### N SEA WALLS AND BULKHEADS

Sea walls and bulkheads are structures built to prevent encroachments of the sea or to enclose a water area to be filled. They are identified on the field inspection photographs, and notes are made if any are in ruins or if any are not located in coincidence with the shoreline.

On the map manuscripts extensive sea walls and bulkheads shall be delineated. Where their positions are in coincidence with the position of the shoreline, they shall be delineated as part of the shoreline (5421). Where they have deteriorated and are in ruins, their remains shall be indicated by legend in vertical letters (See fig 5 28).

**O WRECKS**

Wrecks will be identified on the field inspection photographs. Their heights and appearances relative to the planes of reference are given as for rocks (see 5424).

Where the scale of the map manuscript permits, wrecks shall be delineated to scale if they are larger than 20 mm (0.08 inch); otherwise they shall be symbolized in accordance with figure 523. Bare wrecks shall be delineated in a solid line. Wrecks awash shall be delineated in broken lines. Sunken wrecks shall be shown by symbol. The area covered by several sunken wrecks shall be outlined with a broken line. All wrecks shall be accompanied by the legend "Wk" in inclined letters.

**P LANDMARKS AND AIDS TO NAVIGATION**

All fixed aids to navigation and landmarks for charts shall be delineated. They shall be symbolized as triangulation or topographic stations depending upon the accuracy of location. The names shall be shown as specified in 546. The height above ground and elevation above mean high water will be furnished by field parties and shall be delineated for each landmark as illustrated in figs. 541 and 543. The height above ground and elevation above mean high water shall also be listed on form 567 after the description in the column headed "Description."

*5426 Delineation Within Control Symbols*

Important shoreline detail inside a control station symbol is drawn with a solid black line 0.006 inch in weight, however, this line must never obscure the point that represents the station (see fig. 543).

**543 DELINEATION OF PHYSICAL FEATURES**

This section contains instructions for delineation of drainage, relief, and natural ground cover not included in 542.

*a Planimetric Manuscripts*

The drainage and natural features, except for contours and elevations, are completely delineated on planimetric manuscripts. Because of their relatively large scale, legends are freely used instead of or to supplement symbolization. Alongshore bluffs, levees, and dikes are symbolized by hachures, estimated elevations of alongshore bluffs are given, but otherwise elevations are omitted. Other relief is rarely indicated and then only by hachures, where the feature has landmark value.

*b Shoreline Manuscripts*

A shoreline survey is treated as a planimetric map except that the land area covered is limited to a narrow zone bordering the shoreline.

*c Topographic Manuscripts*

The drainage, the relief, and the natural features are completely delineated on topographic manuscripts so far as is consistent with the scale.

*5431 Water Features*

This section includes water features, such as flowing streams, lakes, ponds, and features which indicate some degree of wetness, such as intermittent streams, marshes, and glaciers. For shoreline and associated alongshore features see 542.

Natural drainage features to be mapped are streams, lakes, ponds, marshes, swamps, springs, glaciers, and washes. The pattern formed by these drainage features is extremely important as it is a guide to the general character of the topography. Therefore the accurate compilation of the drainage net cannot be too strongly emphasized. The completeness of the field inspection of these features depends on the conditions encountered in the field and type of map manuscript that is to be produced.

Drainage features shall be delineated on the map manuscript in black permanent plastic ink and shall be delineated as completely as the scale of the map manuscript permits. Practically all drainage should be delineated on the map manuscripts, as it constitutes a controlling element for all topography and serves as a natural skeleton for the construction of the contours. Where the drainage includes a complex system with many short tributaries the very short ones may be omitted. The photogrammetrist, however, can only delineate drainage that is clearly discernible on the photographs. Frequently the course of drainage can be followed only partly in the stereoscopic model. Where streams or other drainage features are indistinguishable, probable drainage should be indicated and shown on the discrepancy overlay for completion by the field-edit party.

When topographic maps are contoured by planetable, drainage that is *not* unmistakably clear on the photographs is identified and inked on the field photographs during contouring. In this respect drainage is furnished to the photogrammetrist, but office equipment and facilities warrant further study to check and to refine the field delineation.

#### A RIVERS AND STREAMS

Nonnavigable rivers and streams that *can* be unmistakably delineated with the aid of a stereoscope will not be completely inked on the field photographs by the field party. The completion of the interpretation and the delineation are left for the photogrammetrist. He shall delineate the shore of such rivers and streams as it would appear at the normal river stage. The normal stage is defined as the water level which remains nearly stationary for the greater part of the year (9 to 11 months for most streams), thus excluding all high-water stages of relatively short duration resulting from periodic or seasonal floods and all low-water stages resulting from periods of exceptional drought.

Broad rivers are often a perplexing problem to the photogrammetrist because of their periodic fluctuations. The width often varies considerably, depending on the stage of the river. Navigable rivers that fall in this category are thoroughly field-inspected and their shorelines shall be delineated accordingly (see 5421).

Narrow streams delineated with one line occasionally split into two branches that subsequently rejoin to leave an island between the two branches. Such features should be explained by appropriate notes to prevent misinterpretation by the map user.

Streams with a width on the map manuscript of 0.5 mm or more shall be delineated by a double line symbol, those of lesser width by a single line symbol. Where the width changes from one category to the other, the appropriate change from a single line to double lines and vice versa shall be made. (See fig 5 25.)

The shoreline of nonnavigable rivers or streams shall be shown by a line 0.008 inch wide. (See figs 5 6G and H and 5 25.)

#### a Perennial Streams

A perennial stream is one that flows most of the time but that may occasionally dry up. It is represented by a single solid line or a double solid line (see fig 5 25). This symbol indicates where

running water may usually be found. It is possible that a stream may have been dry at the time the photographs were taken, but the field party classified it as perennial. If there is any doubt as to the classification of an important stream, verification should be requested on the discrepancy overlay (see 57)

### **b Intermittent Streams**

An intermittent stream is one that is dry most of the time. It is symbolized by a series of one-dash-and-three-dots (see fig 5 25), either single-lined or double-lined.

### **c Disappearing Streams**

Streams in limestone and lava areas often sink underground and continue in subterranean channels. The points of disappearance and reappearance of such streams shall be accurately delineated and accompanied with appropriate notes, such as "Stream goes underground" or "Stream reappears"

### **d Braided Streams**

A braided stream is one where the normal flow of water does not fill the stream bed, but is carried in a number of small channels, thus dividing the bed into a number of islands or sand bars. These channels should be delineated by the photogrammetrist from the office photographs. Where they are not distinguishable the inner channels may be symbolized within the accurately delineated outer channel limits. (See fig 5 25)

## **B LAKES AND PONDS**

### **a Natural and Artificial Lakes and Ponds**

The shorelines of navigable lakes are thoroughly field-inspected and should be delineated accordingly (see 5421). The shorelines of lakes and ponds whose water levels rise and fall should be delineated at the normal stage of water. The normal stage is usually defined on the ground by a line of permanent vegetation which is generally easy to identify on the photographs.

Lake and pond shorelines are delineated in the same manner as other shoreline (see fig 5 26)

### **b Intermittent Lakes and Ponds**

(Poor See def for Intermittent Stream above)  
The quantity of water in an intermittent lake or pond and the temporary water limits shall be ignored. The permanent boundary (berm) shall be symbolized with a dashed line. The enclosed area shall be filled with diagonal hatched lines on shoreline map manuscripts. On planimetric and topographic map manuscripts this enclosed area shall be identified with the legend *IP*. The berm line of a cypress island or a marsh island shall be similarly delineated with the appropriate symbol within the island. (See fig 5 26)

## **C CRANBERRY BOGS AND SALT EVAPORATORS**

Cranberry bogs and salt evaporators that are larger than 30 by 30 mm in area on the map manuscript shall be delineated in their correct shape. Only the major separations shall be shown. (See fig 5 36)

## **D MARSHES AND SWAMPS**

Fresh and salt marsh shall be indicated in the same manner—no distinction shall be made between them. Marsh or swamp land is defined as land that is generally wet and spongy, but not necessarily covered with water, and land that is not suitable for cultivation until it has been drained. (See fig 5 36)

On topographic and planimetric map manuscripts the limits of inland swamp and the inshore limits of marsh and mangrove are to be delineated by a dashed blue line and the

character indicated by a legend, not symbolized. Some symbolization, however, is permissible where it is essential for clarity.

On shoreline map manuscripts where the marsh area is small or where the manuscript covers only a small area of marsh immediately adjacent to a main shoreline, the marsh shall generally be completely symbolized. But where the marsh area is large, the marsh symbol shall clearly define the limits of the area, but may be omitted in the central part where the character may be indicated by the word "marsh". These are general instructions that should be applied by the photogrammetrist and his supervisor in taking into consideration the final appearance of the manuscript.

Woodland cover in swamps shall be symbolized or indicated with a legend according to the requirements for the specific type of map manuscript. If symbols are used, a combination of water lining and woodland symbols shall be used. (See **5433** and fig 5 36)

#### E SPRINGS

Important springs that are to be shown on the map will be identified in the field, as they cannot ordinarily be identified from the photographs alone.

Whether or not a spring is shown on the map manuscript depends on its relative importance as a part of the water resources of the area. Thus, springs should be shown in arid areas, where they are of vital importance and their omission might be serious to those depending on the map, they should generally be omitted from well-watered areas. The names of springs in arid areas and of conspicuous springs in well-watered areas should be given, accompanied by notes as to whether the springs are intermittent, alkali, undrinkable, hot springs, sulphur, medicinal, or geysers. (See fig 5 26)

On topographic map manuscripts the elevations of springs should be given.

#### F GLACIERS AND PERMANENT SNOW OR ICE FIELDS

Glaciers and permanent snow or ice fields shall be outlined with a fine dashed line and indicated by legend. Moraines in glacial country shall be shown by scattered dots. (See fig 5 26)

On topographic map manuscripts glaciers will be further indicated by form lines. Greater accuracy in delineating glaciers is not warranted because of their constant, although slow, change. Snow or ice fields are to be contoured with about the same accuracy as the surrounding terrain.

#### G WASHES

Washes are deposits of loose, eroded surface material, such as sand, gravel, and other rock debris, transported by running water, or they are the dry beds of intermittent streams, often found in the bottoms of ravines or canyons.

Washes can generally be recognized on the photographs without field identification.

The limits of washes shall be indicated by a fine dashed line, with the perennial and the intermittent streams delineated within the area of the wash. Washes of 1.3 mm width or less are to be delineated as intermittent streams. (See fig 5 25)

#### H MISCELLANEOUS PHYSICAL FEATURES

All physical features that must be delineated on map manuscripts are not individually discussed in this manual nor is there a symbol for every feature to be mapped. The

limits of areal features not otherwise symbolized, such as clay pans and dry lakes, which are of sufficient importance to be mapped, shall be indicated by a fine dashed line with an appropriate legend. Descriptive notes may be added if required for clarity. The purpose is to convey to the smooth draftsman, and eventually to the map user, sufficient information for ready identification.

### 5432 Relief

Relief, or the configuration of the ground, is normally represented on topographic maps by contours, approximate contours, or form lines with occasional hachures, or other symbols. It may be surveyed by field methods or may be mapped by stereoscopic instruments.

Index contours, intermediate contours, supplemental contours, and form lines and their required elevations shall be delineated on topographic map manuscripts in accordance with figure 5 38 in brown permanent plastic ink.

Planimetric maps and shoreline surveys do not show relief, except for cliffs or bluffs, dikes, levees, cuts and fills, etc., that are shown by hachures. Elevations must be given for alongshore cliffs and bluffs.

#### A CONTOURS

Contours are commonly used to show topographic relief. A contour is a line on a map representing an imaginary line on the ground that passes through points of equal elevation. Contours and ground elevations shown on the map manuscripts must be in agreement. Contours indicate the elevation of the earth's surface and by their shapes and spacing indicate the shapes of relief features, such as hills and valleys. Contours are relatively far apart for gentle slopes with the distance between them decreasing as the slopes become steeper.

Closed contours indicate a hill or a depression. A depression is identified by ticks normal to the contour and extending toward the depression. (See fig 5 38.) The elevation of the lowest point of the depression shall generally be indicated.

Contours never split, nor do they cross one another, except in the rare instance of an overhanging cliff. A contour in nature never ends abruptly—it either joins itself, thus surrounding the feature, or begins and ends at the limits of the map.

No map shall contain more than one basic contour interval. The contour interval shall be in accordance with the project instructions. The basic contour intervals for topographic mapping are 5, 10, 20, 40, and 100 feet. The intervals of 25, 50, and 100 feet will be used in Alaska when specified by project instructions.

#### a Index Contours

Certain contours usually every fifth, are emphasized and are called index contours. (Where the contour interval is 25 feet every fourth contour is an index contour.) Index contours are accentuated by a heavier line than the other contours, and are identified by frequent elevations to make reading of the contour system easier. They shall be completely delineated, they are omitted only where they cross double-line drainage features. (See figs 5 38 and 5 39.)

#### b Intermediate Contours

The contour lines between the index contours are called intermediate contours. In some instances intermediate contours may be omitted. They are always shown in comparatively flat areas and where the slopes are moderate. They must not be omitted where they are needed to define changes in slope or where their omission would result in an erroneous interpretation of the relief.

Where the slope of a contoured feature becomes so steep that the contours would merge, or run together, intermediate contours shall be *feathered-out* and selected ones omitted so that there is a space of approximately 0.3 mm between those shown. The selection of those to be dropped is arbitrary (One, two, three, or four intermediate contours may be dropped between index contours). Where a contour is dropped, its end (the last 6 to 3 mm, or the last  $\frac{1}{4}$  to  $\frac{1}{8}$  inch) shall be gradually feathered to invisibility, it shall not be merged with another contour except as stated in the next paragraph. The remaining intermediate contours shall be smoothly respaced to avoid the appearance of non-existent benching between the index contours. (See fig 5.38.)

Intermediate contours may be merged into one carrying contour on levees, spoil banks, etc. (See fig 5.38.)

The elevations of intermediate contours shall generally be omitted but may be shown when needed for clarity.

### c Supplemental Contours

Where the prescribed contour interval is inadequate to show certain significant topographic features, supplemental contours may be used. Their use will usually be provided for in the project instructions, but the specific place they are to be inserted depends on the judgment of the surveyor or the stereoscopic instrument operator.

A supplemental contour is normally a half-interval contour—although it may be a quarter-interval contour—surveyed by field methods, or mapped by stereoscopic instruments, with the same accuracy as regular contours but shown on the manuscript by a broken line. (See fig 5.38.) Supplemental contours are used on maps where the relief varies from steep to gently sloping ground in order to avoid unnecessary crowding of contours on steep slopes and at the same time avoiding too great a contour interval in the flatter areas, i.e. the contour interval specified for the map is based on the steeper slopes and supplemental contours are used to portray the flatter areas and are shown only in these areas. The contour interval and the use of supplemental contours will be specified in the project instructions.

The elevation of each supplemental contour shall be shown on the map manuscript.

### B APPROXIMATE CONTOURS

An approximate contour is a line delineated on a map to represent an imaginary line on the ground that passes through points of *estimated* equal elevation. Approximate contours are used to indicate relief where there are insufficient data to warrant the use of contour lines. Where there is any doubt as to the accuracy of relief representation, approximate contours shall be used. They are used primarily in areas where there is little or no control, so it is doubtful whether they should ever be used on maps of areas in continental United States.

Where contours are being drawn with stereoscopic instruments, approximate contours shall be used in cloud-shadowed areas, where horizontalization of a model is questionable due to a poor parallax solution, where vertical control is lacking or questionable, in heavily wooded areas or even in wooded areas where the diapositives or photographs are of such quality that the photogrammetrist is uncertain of his work. These areas shall be noted on the discrepancy overlay. They will then be checked or revised during field edit or additional control will be added for use in stereoscopic instrument revision.

Approximate contours will be retained on the manuscript until replaced by contours. In the United States this replacement will be done by the field-edit party and approximate contours will rarely, if ever, be shown on the published map. In remote areas, as in Alaska, where completion surveys are not ordinarily made, approximate contours may be shown on the published maps.

### C FORM LINES

Form lines are used to portray the general shapes of topographic features, with little or no reference to a datum plane. They are used only where the available data are not



sufficient to warrant the use of contours or approximate contours. They are rarely, if ever, used for coastal mapping within continental United States.

Form lines are sketched—they are not surveyed lines, they are based on little or no control and are intended only to give a pictorial representation of the relief.

Form lines shall be delineated in brown permanent plastic ink as dashed lines of uniform, fine weight, with the dashes being drawn in irregular lengths in accordance with figure 5 38.

#### D SPECIAL TREATMENT OF CONTOURS

Besides the engineering accuracy of the contours, they must be so shaped as to give the best possible portrayal of the terrain consistent with the scale of the published map and should indicate at a glance the general character of the country—whether flat, mountainous, gently rolling, or strikingly eroded. Attention to small details in the shaping of contours is necessary to accomplish this and to present a natural picture of the terrain. The expression of the relief is adversely influenced by such relatively small items as (a) the inclusion of details inconsistent with the scale of the map, (b) the omission of essential details, (c) over-exaggeration of small features, (d) the use of sharp or curved stream reentrants where the opposite should be used, (e) the drawing of conventional curves rather than the diversified curves normally found in nature, and (f) the drawing of angular forms where rounded forms are characteristic of the area.

Consequently, one of the principal requirements of field edit is to study the contours relative to the ground and to reshape them slightly (generally within the accuracy tolerances), wherever desirable, to improve the relief expression. This is primarily a field-edit requirement but to conserve the time of the field-edit party, the contours shall be critically examined in the office prior to the field edit and obvious changes made as discussed in the following paragraphs, which refer to planetable contouring done on aerial photographs for subsequent compilation on map manuscripts, and to contouring by means of stereoscopic instruments.

The shapes of planetable contours may be improved through stereoscopic study of the photographs in some instances. Where the contouring has been done by planetable on aerial photographs, the office photogrammetrist delineating the map manuscript shall study the shape of the terrain under the stereoscope and be alert to discover errors or inadequacies in the shaping of contours. He may make small obviously desirable changes in the contours to improve the expression of relief, but being unfamiliar with the ground he must refer uncertain areas to the field-edit party.

Where contouring has been by stereoscopic instruments, the contours shall be improved through a separate stereoscopic study of photographs by the supervisor of the stereoscopic instrument section or by a trained photogrammetrist. Errors or inadequacies in the shaping of contours can be discovered and small obviously desirable changes in the contours made to improve the expression of relief.

Whether the contouring is by planetable or by stereoscopic instrument, the shapes of the contours must represent the configuration of the relief and the contours must be accurately related to the control and the culture shown on the map manuscript.

##### a Alignment of Contours

The turns in contours that define steep drainage channels should in general, be in alignment with one another—the closer the spacing of the contours the more exact should be the alignment.

In wooded areas or areas of poor definition small drains and poorly defined drains are often

missed by the stereoscopic instrument operator. These shall be added and aligned during the stereoscopic study of the photographs.

### *b* Tops and Saddles

The contouring of the tops of mountains, ridges and hills and their connecting saddles must be given careful attention as these features are usually the most prominent and the most expressive on a manuscript. They define watersheds, often define civil boundaries and control the distribution and location of routes of communication.

### *c* Depressions

Depressions shall be symbolized by contours with ticks at the regular contour interval. The ticks are drawn normal to the contour on the downhill side. The ticks shall be approximately 0.5 mm in length and the spacing between them shall increase with departure from the center of the depression as illustrated in figure 5.38.

Where the slope of a depression is so steep that the contours become very close, the depression ticks may be reduced in length to 0.25 mm. If this shortening is not sufficient to prevent the ticks from connecting with the contours below, intermediate contours shall be omitted as necessary to achieve legibility.

The elevation of the lowest point of the depression shall generally be indicated.

Where space permits the values of both index and intermediate contours should be shown in the immediate vicinity of depressions.

Depression ticks shall not be shown along the artificial contours formed by railroad or road construction, nor shall ticks be used to indicate artificial depressions formed by dams.

### *d* Levees and Spoil Banks

In areas containing a complex system of drainage or irrigation canals and ditches with spoil banks and levees alongside them the contouring requires special attention to avoid excessive cost and an unwarranted complexity of detail on the published map. The solution is, of course, the elimination of unnecessary detail and the problem confronts both the planetable topographer and the office photogrammetrist. In such areas the contouring of canals, levees, and spoil banks (see fig. 5.40) shall be handled in accordance with the following instructions:

(a) Levees and spoil banks shall be shown by contours only where this can be done without exaggeration, i.e. without displacing the position of either the contours or other features, otherwise the levees, spoil banks, etc. shall be shown as in (b) below.

(b) Levees, spoil banks, etc., of sufficient importance to be shown, but which are too low to be represented by a contour and the higher ones which cannot be shown by contours without exaggeration or displacement as discussed in (a) above, shall be shown by a medium weight brown line (0.015 inch wide at publication scale) along the top of the feature. This line symbol is, in effect, a carrying contour. A contour approaching the levee shall be shown up to and merging with the levee symbol. The symbol shall be continuous and shall be continued uninterrupted even across short stretches where contours could adequately illustrate the condition. Where a road or railroad is on top of the levee the symbol shall be split and shown by a brown line (0.01 inch wide at publication scale) on each side of the carried feature with contour crossings shown wherever they exist, drawn at right angles to and connecting the lines of the levee symbol.

(c) Contours shall not be surveyed or delineated in canals or ditches. The contours representing the ground level outside the ditch shall be shown to the ditch or canal, turned into it for about 2.5 mm, and then dropped.

(d) Spot elevations of the tops of levees and banks shall be shown at occasional points (no more than four per mile).

(e) In contouring such areas the topographer and office photogrammetrist must understand that the principal function of contours is to show the normal slope and shape of the ground. On maps at 1:20,000-scale or smaller contours cannot show all the details of the ditches and banks and this should not be attempted to the extent that the manuscript and the published map cannot be easily read.

### e Cuts and Fills

Cuts and fills whose depths and heights, respectively are equal to or less than the contour interval will generally be omitted

Cuts or fills whose heights exceed the normal contour interval shall be indicated by a carrying contour. A contour line approaching the cut or fill shall be drawn into the symbol at the point where it becomes a part of the slope of the feature. Contour crossings shall be shown wherever they exist and shall be drawn at right angles to and connecting the carrying contours. (See fig. 539)

Ticks shall be shown on both sides of a fill symbol

### f Bridges

Where a bridge is of sufficient length (see 5443A) or importance to be shown on the map manuscript, the carrying contours used to indicate embankments or fills shall be dropped at the bridge symbol

Where small bridges are omitted, contours showing embankments or fills which run parallel to roads shall be run across the roads to represent the ends of the fills

Contours representing land slopes passing under bridges shall not be broken for the bridge symbol

### g Gravel, Sand and Gravel, and Boulder Areas

Gravel, sand and gravel, and boulder areas (see 5433B) generally will be contoured and the character of the area indicated by legend

### h Sand and Sand Dunes

Areas of sand and sand dunes that are relatively stable shall normally be contoured, although the contours may be generalized, when subject to frequent change they shall not be contoured. Where dunes have not been contoured because of their constantly changing positions they shall be symbolized and indicated by the legend "Shifting sand dunes"

## E SPOT ELEVATIONS

Checked spot elevations are elevations of less than third-order accuracy established by closed lines of trigonometric or spirit levels—for the control of planetable or stereoscopic instrument contouring. Unchecked spot elevations are those determined by unclosed lines of levels, such as, side shots from closed level lines, by precise barometric methods, and by stereoscopic instrument

More spot elevations are sometimes determined during field surveys and indicated on the field photographs than are wanted on the final map. In this case, the office photogrammetrist must select the spot elevations to be shown on the manuscript. They shall be selected to supplement the contours, to show changes in grade, to show prominent elevations and depressions not well-defined by the contours, and to show elevations of well-defined points interspersed between bench marks

Spot elevations shall be selected and shown on the manuscripts as follows:

- (a) At road intersections and on other well-defined features, interspersed between bench marks so that there will be an elevation about every mile along the roads
- (b) In areas where there are few roads or well-defined points so that generally there will be one or two elevations per square mile
- (c) On prominent high points whether or not they are well-defined by contours
- (d) On the highest points of hills, knolls, saddles, rises, or other high points where these are not well-defined by contours
- (e) In depressions that are not well-defined by contours
- (f) On important water surfaces, such as lakes and ponds
- (g) In areas where there are numerous small lakes or ponds two or three elevations on the water surface per square mile will suffice

(h) At occasional points (no more than four per mile) on spoil banks and levees in order to indicate the elevations of these features where they are symbolized by the special symbol discussed in 5432D

The office photogrammetrist shall indicate on the discrepancy overlay where additional spot elevations are required to comply with these instructions. These additional spot elevations will be obtained during the field edit.

The delineation of spot elevations on map manuscripts is described in 5467.

#### F HACHURES

Hachuring is a method of depicting approximate relief, especially used in mountainous terrain.

Hachures are lines drawn directly down a slope, at right angles to the contours, for the purpose of representing the slope of the ground—its relative height or its steepness of grade—with no indication of elevation above the datum plane. For a steep slope hachures are heavy and closely spaced, for a gentle slope they are fine and widely spaced. A hachure may run the entire length of a slope—the length of a hachure has *no* direct relation to the height of the feature. See 5473 A

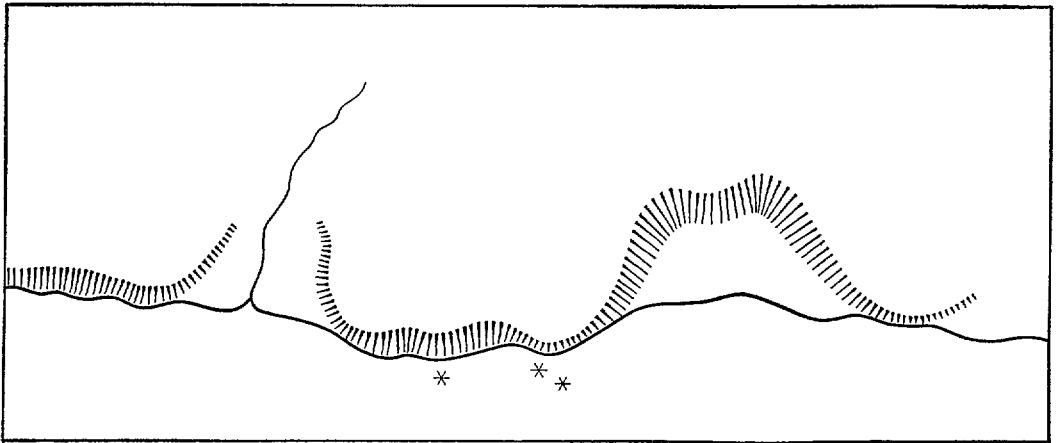

FIGURE 58—Hachures

Where a continuous line is used to indicate the top of a cut or a fill, the hachures are in the form of ticks which show that the slope descends from the line. If no line is used, the hachures are thicker and heavier at the upper end, tapering down the slope. (See fig 539.)

The Coast and Geodetic Survey uses hachures for special purposes only, for they obscure other topographic detail. The use of hachures is illustrated in figure 58, which represents a short stretch of coastline. Interpreting the hachures, on the left is a fairly steep bluff along the shore, which a little farther to the right turns inland away from the beach along a small stream. On the other side of the stream is the end of a low bluff which continues to and around a point, becoming higher and more precipitous. Just beyond the point it is lower but still steep, and then recedes inland, leaving a small beach area. Here it is higher again but not so steep. Approaching the shore again, the bluff becomes lower and steeper and finally turns inland and disappears.

### a Planimetric and Shoreline Manuscripts

Hachures shall be used on planimetric and shoreline maps only to indicate bluffs, cliffs, levees, etc., along the shore and conspicuous landmark cuts, fills, and eroded banks. These features are delineated in black permanent plastic ink in accordance with figure 5-40.

### b Topographic Manuscripts

Hachures shall be used on planimetric and shoreline maps only to indicate bluffs, cliffs, levees, etc., whose heights are less than the contour interval or to represent special landmark features that are not adequately represented by contours. They shall be delineated in black permanent plastic ink in accordance with figure 5-40.

#### 5433 Natural Ground Cover

Natural ground cover embraces vegetation, such as marsh, woods, and grass, or the bare surface of the earth, as sand, rock, etc., where there is no vegetation. This natural cover is completely pictured on aerial photographs, but for it to be correctly interpreted and shown on a map, representative areas must be identified and classified during field inspection. Then it is possible for the office photogrammetrist to classify by analogy all similar growth, including the limited classification of woodland required.

The boundaries of different types of woodland or other vegetation will generally be decided by the photogrammetrist compiling the map manuscript.

The following are general instructions for the delineation of natural ground cover on all manuscripts:

(a) Any natural ground cover that is smaller in area than 30 by 30 mm on the map manuscript may be omitted.

(b) Definite clearings for power lines, telegraph lines, fire breaks, etc., where they are approximately 20 feet or more in width shall be shown by a broken double-line symbol with the minimum width between lines as required. They shall be drawn to scale wherever the width exceeds the minimum requirement. Line clearings less than approximately 20 feet wide shall be shown as a dashed single line and shall be indicated by legend (see fig. 5-30).

(c) Cultivated fields, including fallow fields, truck gardens, flower gardens, and sugar cane, shall not be indicated in any manner.

(d) Grassland and uncultivated fields shall not be indicated in any manner.

(e) Isolated trees shall not be delineated unless they are landmarks.

(f) Scattered trees, brush, or other vegetation shall be omitted along roads, fences, and ditches that are delineated on the map manuscript.

(g) A solid row of trees, such as a windbreak, shall be delineated.

(h) All woodland cover within urban areas shall be omitted.

#### A WOODLAND

Occasional characteristic wooded areas will be classified during field inspection, with notes on the field photographs to enable the office photogrammetrist to differentiate between the several classes of woodland. It is neither necessary nor desirable for the field inspector to classify every wooded area in the field. All other similar areas can then be classified by analogy by the office photogrammetrist.

Wooded areas shall be delineated in accordance with the instructions in this manual.

### a Topographic Manuscripts

<i>Feature</i>	<i>Legend</i>	<i>Description</i>
Woods	T	<u>This class shall include woods and/or brush</u> of sufficient density or height to impede travel either pedestrian or vehicular, and to afford cover for troops In general this refers to <u>growth higher than 6 feet and dense enough so that more than 30 percent of the ground area is covered as viewed from above (on photographs) when the vegetation is in foliage</u> This class shall include (1) Logged-over or burnt over areas where new growth is well established (2) Narrow strips of trees, as along streams, in windbreaks, etc which are prominent and are landmark features in an otherwise open area but not including brush along fence rows (3) Nurseries and reforested areas
Scrub	S	Low or stunted vegetation such as cactus, sagebrush, and mesquite, occurring on poor or sandy soil, (seldom found along the coast except in the southwest), where the growth is thick enough to impede either pedestrian or vehicular travel This type of vegetation is seldom found mixed with "Woods" (T) <u>Brush too low or too scattered to be classified "Woods" (T) shall not be classified "Scrub" (S)</u>
Orchard	O	An area covered by rows of evenly spaced trees or tall brushes that were apparently planted according to plan Open ground is usually visible
Vineyard	V	An area covered by a perennial vine-like vegetation usually planted in close rows artificially supported off the ground
Mangrove	Mg	A dense growth of trees with intertwined aerial roots growing in salt water flats and swamps

All areas that do not fall into one of the above classifications shall be considered "open"

The field instructions are intentionally somewhat general—exact specifications are unwarranted, and the field and office personnel are not to waste time in indecision over whether a marginal growth should be included in one of the classifications or considered "open"

Woodland areas shall be accurately outlined on the manuscript, using a fine curlicue line, as illustrated in figure 5 37 (Note that the points are *toward* and the rounded parts of the line are *away* from the wooded areas, and that the dividing line between two wooded areas of different types is a wavy line) The outline may be omitted where the wooded area abuts some other map feature, such as a stream, railroad, road, or shoreline The outlines and the legends within the outlines shall be in green ink The woodland limits shall be positioned and shaped accurately and not generalized, inasmuch as these are often landmark features

No special woodland symbol is provided to outline mangrove or cypress swamps because it is assumed that a dashed line outlining the swamp area (see fig 5 36) will be adequate Should the occasion arise where inshore limits of flooded areas do not adequately define the limits of the actual mangrove or cypress trees, a woodland outline symbol shall be used where they are not otherwise defined by the shoreline or swamp limits (See fig 5 37)

### b Planimetric Maps

The field inspection of woodland for planimetric maps will include the classification of features required for topographic maps, and *in addition* will classify wooded areas as to the general types of trees

---

Not classified as to type

<i>Feature</i>	<i>Legend</i>	<i>Description</i>
Deciduous Trees	TH	Deciduous trees generally without reference to the hardness or softness of the wood
Evergreen Trees	TS	
Mixed Woods	TM	A mixture of deciduous and evergreen trees

Inasmuch as planimetric maps are printed in one color and the type of woodland is symbolized, large stands of special growth, such as cypress, palm, or palmetto, will be indicated by the field inspector so that the office photogrammetrist can properly symbolize them. However, where the types and/or the special growth are intermingled, a minute and inconsequential subdivision shall be avoided.

Wooded areas shall be delineated in the same manner as on topographic map manuscripts.

### **c Shoreline Manuscripts**

The field inspection is the same as for planimetric maps. Wooded areas shall be completely symbolized in black permanent plastic ink according to figure 5 37, except where the wooded area is large, in which case the symbol may be used to outline the area, thus clearly defining its limits, and may be omitted in the central area. An appropriate classification legend shall be placed in the blank area.

Where a shoreline survey is within the limits of a contemporary topographic quadrangle, the additional field inspection shall be made only for the narrow zone 200 to 300 meters wide adjacent to the shore.

### **B SAND, GRAVEL, SAND AND GRAVEL, BOULDERS, AND SAND DUNES**

Foreshore areas of sand, gravel, sand and gravel, and boulders shall be indicated by legend or symbolization (see **5423D** and figs 5 22, 5 23). Extensive interior areas of these features that are without vegetation shall be outlined and indicated by legend as in figure 5 40. This latter instruction does not apply generally to beaches, the character of which is indicated by the legend or symbolization in the foreshore area and which ordinarily is not indicated back of the shoreline. It does apply to prominent peninsulas and points composed of sand, gravel, etc., without vegetation. (See fig 5 40.) A legend shall be added to indicate the nature of the area. These features shall be delineated in black permanent plastic ink.

Sand dunes are of two types—lateral dunes (sand ridges) and crescent-shaped or horseshoe-shaped dunes (barkhans). The type of dunes in each area is indicated by field inspection. Sand dunes shall be delineated and sand areas shall be indicated by legend on all map manuscripts. The dunes shall be symbolized according to type in black permanent plastic ink. (See fig 5 40.)

### **a Topographic Manuscripts**

Gravel, sand and gravel, and boulder areas shall generally be contoured and the character of the area indicated by legend.

Where sand dunes are fairly permanent they will be contoured, although the contouring may be generalized, where subject to frequent change they will normally not be contoured. Where dunes have not been contoured by the field party because of their constantly changing positions they shall be symbolized and indicated by the legend "Shifting sand dunes."

## 544 DELINEATION OF CULTURAL FEATURES

Cultural features are man-made features, such as roads, piers, buildings, and other structures. Those that occur only in alongshore areas and those that are delineated differently when in alongshore areas are discussed in 5425.

Inshore cultural features are generally delineated in the same manner on all map manuscripts. Any differences are discussed separately under the various separate headings.

Cultural features shall be delineated to scale if the scale of the map manuscript is large enough. (See figures 5 21 through 5 47 for the minimum requirements for size, and see 5413 for the minimum space allowed between drafted lines.) Where the scale is not large enough, symbols shall be used (figures 5 21 through 5 47). Legends shall be used wherever clarity demands it—especially for those features that do not have specific symbols.

All cultural features shall be delineated in black permanent plastic ink on all map manuscripts.

## 5441 Roads and Trails

Roads and trails will be classified by the field party on field photographs for topographic and planimetric maps and shall be delineated in accordance with the following specifications (see 5441A for shoreline manuscripts).

*CLASS 1—Hard surface, heavy duty roads more than three lanes wide.* Roads that carry heavy trailer-truck traffic with a minimum of maintenance and that are four or more lanes in width. Included are dual highways which have two or more lanes on each side of a narrow parkway.

*CLASS 2—Hard surface, heavy duty roads two or three lanes wide.* Roads that carry heavy trailer-truck traffic with a minimum of maintenance and that are two or three lanes wide.

*CLASS 3—Hard surface, medium duty roads more than three lanes wide.* Roads that carry medium heavy commercial traffic in all weather but that are not designed to accommodate heavy trailer-truck traffic. Some maintenance is required from time to time. They are four or more lanes in width and include dual highways which have two or more lanes on each side of a narrow parkway.

*CLASS 4—Hard surface, medium duty roads two or three lanes wide.* Two or three lane roads that carry medium heavy commercial traffic in all weather but which are not designed to accommodate heavy trailer-truck traffic. Some maintenance is required from time to time.

*CLASS 5—Loose surface, graded and drained roads.* Roads designed to carry light traffic in all weather. Periodic maintenance is required. Included in this category are single lane roads whose surface and construction would otherwise place them in a higher category.

*CLASS 6—Improved dirt roads.* Improved roads that are not adequate to carry light traffic throughout the year. Considerable maintenance is required.

*CLASS 7—Unimproved dirt roads.* Natural surface roads, not drained or graded that are generally suitable only for light loads in dry weather. They are seldom maintained and generally without any surface improvement. Short private roads are always included in this category regardless of surface improvement.

*CLASS 8—Trails.* Important footpaths, foot trails, and pack trails are generally included in this category. Tracks which could accommodate jeeps in dry weather are also included.

Any road that has not been classified in the field shall be tentatively classified during delineation by the office photogrammetrist who shall also note on the discrepancy overlay that the road is to be properly classified during the field-edit survey.

Lane information shall be taken from field notes only, as this information is often based on posted signs and lane division strips.

Roads will generally not be classified nor lane information furnished within populated areas, except where streets serve as important connections between through routes, such as Federal and State highways, or alternate unmarked through routes.

All roads shall be identified by route numbers and names, where available.



Roads under construction shall be so indicated

Roads are to be completely delineated on map manuscripts, with the side limits in the positions they will have on the published map. The office photogrammetrist must displace, as necessary, buildings, contours, and other features alongside roads where the actual road width is less than the required minimum drafting width (5413)

All roads wider than a specified minimum shall be drafted to scale. Minimum road widths for map manuscripts compiled at the same scale at which they will be published are given in figure 5 31. The width of a road is the over-all distance between the outsides of the lines on the map manuscript.

It is to be noted that the required road widths, as specified in figure 5 31, at some map scales are considerably greater than if they were drawn to scale. For example, on a 1 10,000-scale map manuscript to be published at a 1 24,000-scale, the minimum width for a Class 1 road is 2.2 mm or 0.09 inch. This represents a width of 74 plus feet on the ground, whereas a 3-lane road might be only 30 feet wide. These minimum road widths may, at first, appear incongruous but they are specified to provide consistency in the office drafting and reproduction of the maps (See 541)

All traffic circles and clover leaves shall be delineated in their true shapes and locations, where space permits. Where it is not practicable to draw these features to scale they shall be symbolized according to figure 5 32.

The two separated parts of a dual highway shall be correctly positioned, if the drafted lines are not closer together than 0.3 mm (see 5413). Each half of a dual highway shall be treated as an individual unit for symbolization and lane information. Where the scale does not permit both sides of a dual highway to be delineated individually (in general, where the dividing parkway is less than 25 feet wide at 1 20,000-scale or less than 50 feet at 1 40,000-scale), the road shall be symbolized by three parallel lines with the center line representing the parkway and at the same time acting as a common side for the two roadways. In this case the dual highway shall be classified as a unit. Lane widths shall be in accordance with figure 5 31.

Hard-surfaced roads are occasionally only one lane wide. Such roads are symbolized as Class 5 roads with the accompanying legend, "Hard surface, 1 lane."

Roads shorter than 8 mm (0.3 inch) on 1 20,000-scale map manuscripts or 16 mm (0.6 inch) on 1 10,000-scale map manuscripts shall be omitted. This limitation shall be applied proportionally on manuscripts at other scales.

Private roads, lumber roads, etc., that only lead to fields or to woods shall generally be omitted. If they lead to camps, sawmills, places of residence, or to the shore of navigable waters, they shall be shown. Where a road follows a stream bed, both features shall be delineated, no attempt shall be made to move a road that coincides with a stream symbol. In areas of sparse culture where there are few recognizable map features, lumber roads or other accessible roads should be delineated if they are definite landmarks.

Only those trails—footpaths, foot trails, pack trails, and trails that jeeps can travel in dry weather—that have a definite origin and destination shall be delineated. Where a trail follows a stream bed, both shall be delineated—no attempt shall be made to change the alignment of either feature where they coincide. Trails on top of levees shall be omitted where the levee is symbolized.

Road classifications shall be added at junctions, at intersections, and at the points of exit from populated areas. These classifications shall be repeated wherever clarity demands it. The classification will generally be placed immediately above and parallel to the road to which it refers.

Changes in numbers of lanes shall be indicated by ticks 1.5 mm (0.06 inch) in length at right angles to the roads at the points where the changes occur. Ticks are not used where changes occur at junctions, intersections, or at points of exit from populated areas. The number of lanes of a multi-lane highway (more than two lanes) shall always be placed adjacent to such ticks.

Where roads have Federal and/or State route numbers, the numbers shall be shown at junctions, at intersections, at points of exit from populated areas, and wherever necessary for clarity. The route numbers of all roads crossing the map limits shall also be shown near the map manuscript limits. Where a road is a combination of routes, all route numbers shall be given. The names of well-known and important roads shall also be shown. The legend "Toll Rd" shall be appended to the name or number of toll roads. All names and numbers shall preferably be placed immediately above and parallel to the roads.

Roads under construction shall be delineated in the same manner as constructed roads, except that broken lines are used and the legend "Under constr" is added, if their classification is unknown the symbol for minimum width Class 5 roads shall be used (see fig. 5.31). Where construction is nearly completed and it is probable that the road will be in use by the time the map is published, it shall be symbolized as a constructed road. Proposed roads shall *not* be shown.

Road objectives shall be shown in the margins of all topographic manuscripts. A road objective symbol is an arrow pointed in the general direction of a destination with the name of, and the distance to, the destination shown thus:

ROME  
  
 61 MI

The photogrammetric office shall compile all road objectives to destinations within a map project or contemporary adjacent project. All other road objectives shall be compiled in the Washington Office. *Road objectives shall not be compiled for planimetric or shoreline manuscripts.* In no case will a road objective or the mileage thereof be determined by field inspection or field-edit parties, except on the specific instruction of the Washington Office. Road objectives shall be compiled and shown on map manuscripts as follows:

(a) Space permitting, all roads in classes 1 to 4 shall usually have a road objective showing a double destination.

(b) Class 5 roads shall usually have a road objective showing only a single destination, but in sparsely settled areas it may be advantageous to show a double destination. In congested areas road objectives for this class road shall be omitted.

(c) In very sparsely settled areas it may sometimes be desirable to show road objectives for roads of lower classifications, and in areas where few or no roads exist, objectives of trails shall be shown.

(d) Designation of destination:

- (1) A double designation shall indicate the first immediate destination and the next important destination. If a road objective has a double designation, the first or nearest destination shall be shown nearest to the neckline.
- (2) A single designation shall indicate the next immediate destination.
- (3) An immediate destination need not necessarily be the name of a populated place, but may be the route identification of a road, such as where a road terminates at another road.
- (4) Immediate destinations ordinarily will be either on an adjoining map or, where a road cuts across a corner of an adjoining map on a map which joins the latter and whose corner touches the corner of the subject map.

- (5) Where a road terminates at another road the route number of the latter shall be the destination and shall be worded thus

*5 Mi to U S 90*

(c) Mileage

- (1) The mileage to the destination shall be measured along the centerline of the main traveled route
- (2) In measuring mileage to a town or city the center of the town or city shall be regarded as the point of destination
- (3) A destination less than 10 miles distant shall be shown to the nearest tenth of a mile
- (4) A destination more than 10 miles distant shall be shown to the nearest mile
- (5) A populated place may be listed as a destination even though the road does not actually enter it, but bypasses it. The mileage to be shown shall be measured to the populated place and not to the junction of the main road with the road leading into the populated place
- (6) Mile or miles shall always be abbreviated, Mi

(f) Two roads with the same destination. Where two roads have the same destination and are close together at the neckline, an arrow shall be shown for each road, but the same note may be used for both roads where the distance to the destination is the same

#### A SHORELINE MANUSCRIPTS

On shoreline manuscripts, roads shall be limited to two classifications. (1) all roads in classes 1 to 5 shall be delineated with the symbol for class 5 roads, figure 5 31, (2) roads in classes 6 to 7 shall be delineated with the symbol for class 7, figure 5 31

Trails, class 8, shall be delineated with the trail symbol, figure 5 31

Roads wider than the specified minimum for the class 5 road symbol shall be delineated to scale

#### *5442 Railroads and Carlines*

Railroads are of two widths—standard gage and narrow gage. The field party will indicate the number of tracks, the stations, the turntables, etc., and especially note any narrow-gage lines. Abandoned and dismantled railroads and those railroads that are under construction shall also be specified. An abandoned railroad is so classified because it is entirely or almost entirely intact and because it can be put into use with a reasonable minimum of repair. A dismantled railroad is so classified because its tracks and bridges have been removed.

Railroads are delineated in black permanent plastic ink in the same manner on all types of map manuscripts (see fig. 5 33)

All surface railroads are delineated. Where railroads run underground in a city they shall be symbolized only to the tunnel entrances. The tunnel symbols or headwalls and wing walls shall be shown. Dashed lines indicating the tunnel alignment are to be omitted.

Railroads in streets or roads shall be shown by crossties properly spaced to indicate the gage. The lengths of these ties shall equal the width between the street lines, providing this width does not exceed the specified tie length for symbolizing railroads (see fig. 5 33). Where the width of a street or road exceeds the required tie length, the complete railroad symbol shall be shown. The required minimum spacing of approximately 0.3 mm between drafted lines shall be followed.

Where railroads of two different gages occupy the same roadbed, the standard gage railroad shall be symbolized and the other railroad will be shown entering and leaving the standard gage lines. If the coincidence of lines is for a considerable distance, legends shall be used to clarify the conditions as

N Gage RR on same roadbed

Where two railroads parallel each other, each shall be symbolized, but the crossties shall be staggered for distinction

*Railroad sidings*—Where the scale permits, single sidings shall be correctly positioned, making certain that the minimum spacing requirements for drafted lines is met. All sidings or spurs running to the waterfront must be clearly indicated. Sidings less than 0.3 mm (0.012 inch) in length shall be omitted. All sidings shall enter the main lines in smooth curves.

*Railroad yards*—The correct shapes of railroad yards, as marked by their limiting tracks, shall be delineated. All main lines traversing the yards shall be accurately delineated if they are distinguishable or are noted during field inspection. The other tracks shall be symbolized. If a yard has more than five parallel lines—not including the main lines—the crossties shall be staggered as indicated in figure 5.33.

*Railroad stations*—Railroad stations are to be delineated to scale and are to be correctly positioned where the station building measures 0.5 mm (0.02 inch) by 0.5 mm (0.02 inch) or more at the scale of the manuscript, otherwise the station shall be symbolized (see fig. 5.33). This symbol shall be centered across the track symbol with the long sides parallel to the crossties. See 5416E concerning the names of railroad stations.

*Railroad roundhouses and railroad turntables*—Railroad roundhouses shall be delineated to scale (fig. 5.33)—not symbolized.

Railroad turntables shall be symbolized (fig. 5.33). The diagonal line in the symbol should not connect any two tracks.

*Carlins*—A carline is any line on which light coaches or cars are generally operated as single units.

Neither surface nor elevated carlines shall be shown in streets or roads. They shall only be shown where the right of way is cross-country and where they enter or leave streets or roads.

Subways shall be omitted.

#### 5443 Bridges Other Than Over Navigable Waters, Viaducts, Overpasses and Underpasses

A *bridge* is a structure erected over a river, stream, or open body of water for the purpose of carrying railroads, roads, or foot traffic.

A *viaduct* is a structure erected over a depression, valley, or gorge, or over areas of dense culture, such as city streets, for the purpose of carrying railroads and roads. The distinction between a bridge and a viaduct is that a bridge passes over what is predominately open water and a viaduct passes over what is predominately land.

An *overpass* is a short viaduct carrying a railroad or a road over another road or railroad. The overpassing feature is generally above ground level.

An *underpass* is a short passageway permitting a road or railroad to pass under another road or railroad. The underpassing feature is generally below ground level.

#### A BRIDGES OTHER THAN OVER NAVIGABLE WATERS AND VIADUCTS

Bridges other than over navigable waters and viaducts shall be shown on all manuscripts if they are permanent structures and fulfill either of the following conditions:

(a) If they are approximately 300 feet or more in length.

(b) Regardless of length, bridges and footbridges shall be shown in areas of sparse culture where they serve as important landmarks and serve as the only means of crossing in the area.

Bridges and viaducts shall be symbolized in accordance with figure 5.32. The type of construction need not be indicated. The cross ticks of the symbol shall mark the correct locations of the end abutments.

The shoreline of a stream or river shall not be broken for the bridge symbol

Roads or railroads passing under a bridge or a viaduct shall be broken 0.5 mm from the symbol (see fig 5 32)

Railroad cross ties shall not be shown within a bridge symbol, but shall be stopped 60 mm from the end cross ticks of the bridge symbol (see fig 5 32)

#### B OVERPASSES AND UNDERPASSES

Overpasses and underpasses shall be shown wherever they exist. They shall be shown by breaking the symbol representing the underpassing feature 0.5 mm from the symbol for the overpassing feature (see fig 5 32)

Where a street or road ends at a road or railroad the symbol for the street or road shall be closed off to avoid its being mistaken for an overpass or underpass (see fig 5 32)

Where there are crossings at more than two levels, they shall be symbolized accordingly. A cloverleaf or partial cloverleaf crossing shall be drawn to scale and similarly symbolized if space and scale permit (see fig 5 32)

#### 5444 *Power Lines, Telephone Lines, and Telegraph Lines*

All trunk power transmission lines and all major cross-country telephone lines and telegraph lines shall be delineated on all map manuscripts, except in urban areas and alongside highways and railroads. The field party will indicate these lines and will state the clearances above mean high water for lines crossing navigable waterways.

All lines over navigable waterways shall be delineated—no exceptions shall be made. Clearances above mean high water shall be stated for these lines. Where the information is not available at the time of compilation, it will be obtained during the field edit.

Power lines and telephone lines shall be symbolized in black permanent plastic ink on all map manuscripts (see fig 5 30). The legends will be repeated as often as clarity demands.

#### 5445 *Stone Walls, Stone Fences, Fences, Hedges, and Crop Lines*

Extensive stone walls or fences shall be delineated in accordance with figure 5 30. Small walls around dwellings, etc., shall be omitted.

Fences (other than stone or masonry) and hedges generally will not be mapped. However, where a fence or hedge is a prominent feature in an otherwise undeveloped area, or for other reason is particularly important, it should be mapped. Where fences and hedges are delineated, they shall be shown with a broken single line and indicated by the note "fence" ("F") or "hedge" ("Hdg") (See fig 5 30).

The field party will indicate those fences or walls (permanent masonry, stone, etc.) and hedges (prominent) that are to be delineated.

In some cases the project instructions may call for the delineation of all fences and hedges, except those along roads, railroads, etc., and around dwellings, as an aid to the field-edit party or as an aid to planetable contouring where this is done on a planimetric base map. In this case the field edit will indicate the permanent stone or masonry fences and prominent hedges that are to be retained on the manuscript—that is, those that are to be mapped.

These features shall be delineated in black permanent plastic ink in accordance with figure 5 30. Wherever displacement is necessary because of congestion, these features shall be eliminated.

Crop lines (lines formed at the junction of different crops) are temporary and shall not be delineated on any map manuscripts.

### 5446 Buildings

Buildings are generally divided into two classes for the purpose of field inspection and delineation.

*Class I* includes buildings of *substantial* construction with a roof and *enclosed* sides that are designed and built for human occupancy—either as dwellings or places of employment or congregation. Included in class I are dwellings, whether or not they are occupied, apartment houses, hotels, churches, and schools regardless of size, and hospitals, buildings open to the public, shops, factories, and other industrial or commercial buildings, that are as large as or larger than the average size of dwellings in the locality. Cabins, sawmill camps, and similar small buildings—whether of permanent or temporary construction—shall be included in this category only if they can be regarded as landmark features in interior areas of sparse culture or along the shore. Filling stations and/or small shops shall be included if they are buildings of substantial construction that are approximately as large as or larger than the average size of the dwellings or other class I buildings in the locality.

*Class II* includes all buildings and similar structures of substantial construction as large as or larger than the average dwelling in the locality and that are excluded from class I. Class II buildings generally have roofs, but are not necessarily enclosed on all sides. Included in this category are barns, grandstands, railroad sheds, fruit packing sheds, large open sheds, large greenhouses, snowsheds, open-air refineries, and buildings of a similar nature.

Class II buildings that are smaller than the average dwelling in the locality shall be mapped only where they are conspicuous (landmark features) in an interior area of sparse culture or along the shore.

A *public building* is any building maintained for general public use, in contrast to private use, such as a courthouse, customhouse, post office, railroad station, church, school, etc.

A *landmark building* is one that <sup>which is</sup> is significant because of its height, <sup>size</sup> size, shape, or location, particularly one whose height makes it important to aeronautical charts either as an obstruction or as a landmark, or one visible from the water whose location, shape, size, or height makes it a landmark for navigation. As to its significance as a landmark, the size of a building is relative—in an open area a small building might have landmark value, whereas in a city with numerous large buildings only the larger or higher and most outstanding ones have landmark value.

Unless otherwise specified in the project instructions, buildings will be classified and characterized, and the required proper names and functional names given, by the field party prior to compilation, thus furnishing all data needed by the photogrammetrist in delineating, symbolizing, and naming the buildings on map manuscripts in accordance with the instructions of this manual. The field data for buildings will be recorded on the field photographs as follows:

- (a) Buildings not to be mapped will be "X-ed" out on the photographs.

(b) Where the outline of a building to be mapped is not clear, the outline will be inked on the field photographs

(c) Class II buildings will be indicated by the number "2" placed alongside them, or nearby with a leader

(d) Class I buildings will not be designated, as all buildings not designated as class II will be assumed to be class I

(e) Functional names and proper names of buildings will be recorded on the field photographs and referenced to the buildings by arrows (See 5416) Where necessary because of congestion these names may be recorded in a clear place on the field photographs, or on the back of the field photographs and referenced to the buildings by letters

Where topographic maps are to be compiled by stereoscopic instrument methods, the project instructions may omit or limit the field inspection of buildings prior to compilation, thus leaving all or part of this to field edit Under these circumstances, the photogrammetrist shall compile all the buildings visible on the photographs, drawing in open outline all those not field classified, but with their shapes and sizes in accordance with 5446B, C, and D

#### A GENERAL INSTRUCTIONS FOR BUILDING DELINEATION

Buildings and structures of both class I and II shall be delineated on all manuscripts according to these general instructions

(a) All buildings and structures discussed under this heading shall be delineated in black permanent plastic ink on all map manuscripts Specific instructions concerning naming buildings and structures are given in 5416

(b) The photogrammetrist shall adhere to the correct symbolization and line weight in order that the feature may be clearly reproduced (see 541 and 5413) Each feature must be in its correct shape, not distorted, and it must be correctly positioned and oriented

(c) All class I and class II buildings shall be mapped everywhere except in urban areas Small buildings ordinarily excluded from class I or class II but which are significant (i.e. landmark features) because of their isolation or conspicuousness in areas of sparse culture and particularly small buildings along the shore that have landmark value for navigation shall be mapped

(d) Public buildings, landmark buildings, and buildings immediately along the waterfront shall be mapped in urban areas, all other buildings in urban areas shall be omitted Even in urban areas all waterfront buildings except minor ones shall be mapped because of their importance in navigation (see 5425c) Buildings from the shoreline inland to the first street paralleling the shore or to a distance of about 300 meters, whichever is less shall be mapped Buildings on piers shall be mapped

(e) Buildings are often so dense outside urban areas that it is impossible to show each building by its prescribed symbolization This condition frequently occurs in small communities and along highways In such instances the size of the building symbol may be reduced to 0.5 by 0.5 mm or buildings may be omitted as necessary so that the remaining ones may be shown by individual symbols Care must be taken to return the general pattern of the buildings in the area The photogrammetrist shall avoid distorting the shape or exaggerating the size of such congested areas

(f) Buildings shall be retained in the following order of preference public buildings landmark buildings and structures, and dwellings

(g) Where the conventional symbol is used for a small building the center of the symbol must be in the exact geographic position of the center of the feature The only exception to this is (h) below

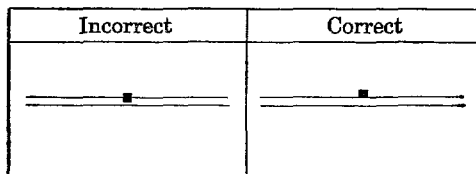

FIGURE 59—Displacement of a building along a road

(h) Where a building is so close to a road that its symbol would fall within the road symbol the building symbol shall be moved back until its edge coincides with the road symbol as illustrated in figure 59 Under no circumstances shall the symbol for the structure be moved back from the road symbol to show the true ground distance between the structure and the edge of the road

(i) Attached row houses shall be shown as one long building or "block" symbol Where attached and detached houses are intermingled, the correct number of buildings shall be shown, if possible—the length of the symbol representing the row houses being slightly decreased if necessary

(j) Where business buildings are contiguous within a block, the buildings shall be shown as a solid row A covered driveway into a building courtyard, or parking area shall not constitute a break in the building

(k) Tourist cabins of substantial size and construction shall be delineated in accordance with 5446A(e) Small, poorly constructed, and closely spaced cabins may be omitted The cabin area shall be outlined with a dashed line and the legend "TC" (tourist camp) placed within the outline

(l) Figure 543 illustrates the delineation of buildings inside station symbols and shall be followed On topographic manuscripts where a horizontal point of less than third-order accuracy—that is, a topographic photo (topo), or photo (hydro) point—is on a building, both the station symbol and the building shall be delineated This is necessary in the case of topographic manuscripts because of the fact that while the stations must be clear on the manuscript for Bureau use, they are usually omitted from the published topographic map Consequently, the buildings must be retained and the station symbols deleted during the Washington Office review or during smooth drafting The building shall be delineated on the manuscript in outline only and the outline may be broken for the station symbol, provided it is delineated in sufficient detail for completion later in the Washington Office If the building is a class II building, that fact shall be indicated by the number "2" placed alongside the building

Trailers, the temporary additions to parked trailers, and the roads in a trailer camp shall be omitted

## B DELINEATION OF CLASS I BUILDINGS

Class I buildings will generally be delineated according to their size and type The buildings of this class, except churches and schools (see 5446D), are divided by size into three categories

(1) *Small buildings* are those 0.6 by 0.6 mm or smaller at manuscript scale They shall be delineated as solid black squares 0.6 by 0.6 mm This is the minimum size at which buildings will be delineated on a map manuscript, except as discussed in 5446A(e) (See fig 534)

(2) *Large buildings* are those larger than 0.6 by 0.6 mm at manuscript scale with no dimension longer than 60 mm Their actual shapes shall be delineated in solid black (See fig 534)

(3) *Unusually large buildings* are those with at least one side longer than 60 mm at manuscript scale The actual shapes of these buildings shall be delineated in outline with the interior cross-hatched i.e., two sets of diagonal lines intersecting at approximately 90°, 45° to the side of the building (See fig 534) The lines of the cross-hatching shall be from 0.06 inch (1.5 mm) to 0.10 inch (2.5 mm) apart

Schools and churches in this category are exceptions and shall be shown in solid black

## C DELINEATION OF CLASS II STRUCTURES

The field inspection party will indicate class II buildings and structures by the number "2" alongside them or nearby with a leader Only those class II buildings as large as or larger than the average dwelling in the locality shall be shown except where they are landmarks

(1) *Small structures* are those 0.6 by 0.6 mm or smaller at manuscript scale They shall be delineated as open squares 0.6 by 0.6 mm This is the minimum size at which structures will be delineated on a map manuscript (See fig 534)

(2) *Large structures* are those larger than 0.6 by 0.6 mm at manuscript scale with no side longer than 15 mm Their actual shapes shall be delineated in outline (See fig 534)



(3) *Unusually large structures* are those with at least one side longer than 15 mm at manuscript scale. The actual shapes of these structures shall be delineated in outline and hatched in one direction at 45° to the side of the structure. (See fig 5 34.) The hatch lines shall be openly spaced, i.e. from 10 mm (0.04 inch) to 25 mm (0.10 inch) the amount of spacing depending on the size of the building. For the smaller of such structures the hatching may consist of only one line.

#### D DELINEATION OF CHURCHES AND SCHOOLS

Although churches and schools have been included in class I, they require special attention and special symbolization. They will be identified by the field party.

Churches and schools smaller than 0.6 by 0.6 mm at manuscript scale shall be represented by solid black squares 0.6 by 0.6 mm in size with the appropriate insignia in accordance with figure 5 34.

The actual shapes of churches and schools larger than 0.6 by 0.6 mm at manuscript scale shall be delineated and inked in solid black with the appropriate insignia in accordance with figure 5 34.

As many of a group of buildings constituting a college, university, school, or religious institution shall be delineated as the scale of the map permits. The school symbol shall be shown on only the administration building if this building has been identified by field inspection, otherwise the symbol shall be shown on the most prominent building of the group. The cross symbol shall be shown on the building used primarily for religious worship in a group of buildings of a religious institution. If the specific building has not been identified by field inspection, the cross symbol shall be shown on the most prominent building in the group.

Where a building is used both as a church and as a school, it shall be classified according to the predominant use. A church or a school building not in use as such shall be appropriately symbolized if it is still available for its intended purpose.

#### E RUINS

Ruins are buildings or structures that are in such a state of dilapidation or decay that they can no longer be used for their original purpose. Those that are to be mapped will be identified by the field party. Ruins within urban areas will not be mapped unless they are of historical importance. For purposes of delineation, ruins are divided by size into two classes.

(1) Ruins that are 0.6 by 0.6 mm or smaller at manuscript scale will not be mapped unless they are landmarks. Where mapped they shall be delineated as open squares 0.6 by 0.6 mm in size. They are to be identified by the word "Ruins" (See fig 5 34.)

(2) The actual shape of ruins larger than 0.6 by 0.6 mm at manuscript scale shall be outlined by a broken line. The word "Ruins" is to be clearly lettered within the feature where practicable. (See fig 5 34.)

#### F URBAN AREAS

An urban area is a continuous area of material size, occupied by a concentrated population that has attained approximately 75 percent of the ultimate maximum development and is at least 0.4 by 0.4 mile in size. It is an area laid out in a definite street pattern and contains, in part, a business or industrial district of contiguous buildings or of buildings which are of such density that their symbols would merge at publication scale. Within such an area only public, landmark, and waterfront buildings shall be mapped. The term "urban area" has no reference to political limits, legal designations, or map limits.

The limits of urban areas will be tentatively selected in the Washington Office prior to field inspection and indicated on the field inspection photographs, on a special set of photographs, or on a mosaic. The tentative urban area limits indicated on the photographs will be evaluated by the field inspector and may be revised wherever field examination indicates that the original limits do not fit the actual field conditions. In some instances

—particularly when the field inspection is under the supervision of the photogrammetric office—the selection of the urban limits may be assigned by the project instructions to the Officer-in-Charge of the photogrammetric office

### *a* The Determination in the Photogrammetric Office of the Limits of Urban Areas

For uniformity of treatment a preliminary study of areas to be mapped is necessary to determine whether or not they include urban areas. Such a study should be made by the Officer-in-Charge of the photogrammetric office with the aid of aerial photographs, city maps, and other available information.

Aerial photographs permit a comprehensive and comparative study of the project as a whole and permit an individual study of each possible urban area. The limits of an urban area are almost immediately apparent as are questionable items that may require solution by inspection in the field.

(a) The selection of urban areas shall be made in advance of the actual compilation.

(b) Each area shall be tentatively selected and outlined on prints of the photographs or on a mosaic, subject to field verification. Each possible urban area shall be studied by stereoscopic examination and outlined on the photograph in accordance with the following:

- 1 Minimum size
- 2 Degree of congestion
- 3 Arbitrary smoothing out of limits

(c) These outlines shall be transferred to the manuscript prior to the delineation of the buildings.

The establishment of the limits of an urban area is largely a matter of judgment. An urban area should usually be shown as a continuous entirety, omitting adjacent sections which do not appear to be integral parts of the major area. Thus a small suburb or development which constitutes an entirety in itself and which is disconnected from the central area or which is connected by only one or two streets ordinarily should not be regarded as a part of the central urban area but should be treated as a separate case.

In establishing the limits of urban areas the Officer-in-Charge shall bear in mind that only public landmark and waterfront buildings are shown within such areas. An urban area not only includes the congested section of a populated place but also includes contiguous street developments where the buildings, although moderately numerous, are widely spaced as compared to the more congested section. Consequently, the outline for each urban area shall be made on a somewhat general and rather broad basis. It should not be cut up and broken with many indentations in an attempt to show exactly where the building spacing changes from the congested to the more open condition. Lines bounding urban areas within which houses are omitted may be variously located—in places they may follow roads; in other places they may follow jurisdictional boundaries, and in still others they may follow railroads, canals, streams, etc.

After the selection of urban areas in accordance with the definition and the instructions in the preceding paragraphs, the area shall be outlined in the following manner:

(1) Sketch the outline around the outer limits of the urban area to include all areas in which the street system is approximately complete, provided the houses in the area are moderately numerous. Exclude areas in which the buildings are not moderately numerous even though the street system might be approximately complete; exclude undeveloped areas; exclude military posts; and exclude fingers of buildings running out along main highways. While it is preferred to have the outline coincide with streets or other linear culture features, departures are permitted where necessary.

(2) Reconstruct the outline, smoothing it out to obtain a consistent treatment around the limits of the area. Usually this final selection will be in the nature of a compromise since the inclusion or the exclusion of a particular small area of streets will depend to a degree upon comparison with adjoining small areas and the general appearance of the outline as a whole.

The following factors control the tentative selection of urban limits:

(1) Any area which otherwise comes within the definition of an urban area but which is less than approximately 0.4 by 0.4 statute mile shall not be regarded as an urban area. Unless unusual circumstances prevail, areas which conform to the definition and which are equivalent to or larger than approximately 1 by 1 statute mile shall be regarded as urban areas.

(2) The decision as to areas between 0.4 by 0.4 mile and 1 by 1 mile will depend upon circumstances and will be the prerogative of the Officer-in-Charge. Various factors will control his decision.

- (a) A large area for example covered with a definite street pattern might contain only a few blocks of dense construction with the remainder of the area containing a small number of buildings which are comparatively widely spaced. An incorrect impression would be conveyed if such an area were treated as an urban area.
- (b) Similarly it would be incorrect to apply urban limits to an isolated suburban residential development.
- (c) If a manuscript contains a large urban area, it is practicable and desirable to apply the treatment to the smaller congested areas also. In such cases it is permissible to disregard the minimum size and to apply the treatment to areas less than 0.4 by 0.4 mile. In making such departures however, careful consideration must be given to all factors.

### b Open Areas Within Urban Areas

Parks, cemeteries, industrial establishments, institutions such as colleges, schools, or hospitals military cantonments etc, with extensive open grounds shall not be regarded as part of the urban area if they are equivalent to or larger than one average block. They shall be regarded as open areas. Those smaller than one block shall be included as part of the urban area.

Undeveloped areas and areas in which the buildings are not moderately numerous, even though the street system might be moderately complete shall not be regarded as part of the urban area if they are equivalent to or larger than two average blocks. Similarly, large natural or artificial features which contain few streets and buildings shall be included in this category, very often areas of these types divide the urban area section since their retarded development materially alters the urban pattern. The areas described shall be regarded as open areas. Those smaller than the equivalent of two average blocks shall be included as part of the urban area.

Open areas shall be clearly indicated on the map manuscript and shall be treated as any other non-urban areas—all map detail shall be shown including woodland cover.

The limits of urban areas shall be delineated in black permanent plastic ink on all manuscripts (see fig 5.43)

### c TANKS

Tanks of all types shall be delineated on the map manuscript regardless of the use to which they are put—that is, whether they are water tanks, oil tanks, gas tanks, etc. Oil tanks shall be accompanied by an appropriate legend, i.e., "Oil tanks"

#### a Circular Tanks

- (1) Tanks with a diameter of 0.6 mm or less at manuscript scale shall be symbolized by a solid black circle 0.6 mm in diameter (see fig 5.34)
- (2) Tanks between 0.6 and 2.0 mm in diameter at manuscript scale shall be delineated at actual size in solid black (see fig 5.34)
- (3) Tanks larger than 2.0 mm in diameter shall be delineated in outline with the interior hatched at 45° to the bottom limit of the map manuscript (see fig 5.34)

#### b Horizontal Tanks

- (1) A small horizontal tank shall be symbolized by a single line (see fig 5.34)
- (2) Where horizontal tanks are grouped so closely that it is impossible to delineate each one and allow the minimum spacing tolerance (0.3 mm), the outside tanks shall be correctly positioned the intermediate tanks omitted as necessary and the remaining ones shown by individual symbols.
- (3) Horizontal tanks larger than 0.5 mm in width and 2.0 mm in length at manuscript scale shall be outlined and hatched at 45° to the long side of the tank.

### 5447 Airports

All airports, airfields, airstrips, etc, shall be delineated on all map manuscripts. The limits of airports will be furnished by the field party and these limits shall be shown on the

⊕ separators, fuel tanks, refueling tanks, etc

manuscript (figs 5 35 and 5 43) The outlines of runways, taxiways, parking aprons, and dispersal areas shall be completely delineated Where runways are identified by numbers painted on them, those numbers shall be shown on the map manuscripts Where there are control towers or other aids to air navigation, they shall also be delineated Where the field party has furnished notes as to the operation of the control towers, these notes may be added to the map manuscripts Use should be made of U S Coast and Geodetic Survey Airport Obstruction Plans and Profiles where these are available All airport features shall be delineated in accordance with figure 5 35 in black permanent plastic ink Airports shall be indicated by name in accordance with **5416K**

### a Topographic Manuscripts

Airports shall be contoured on topographic maps The official elevation of the airport shall be given if it has been determined, otherwise the elevations of the ends of the runways and the elevations of the intersections of the runways shall be shown if they have been furnished by the field party

5448 *Cemeteries, Fairgrounds, Golf Courses, Race Tracks, Ball Parks, Stadiums, Zoos, etc*

#### A CEMETERIES

The actual shapes of cemeteries shall be shown in outline in black permanent plastic ink on all map manuscripts Small cemeteries less than 1 5 by 1 5 mm in size at manuscript scale shall be omitted unless they constitute landmarks in sparsely settled areas All cemeteries shall be identified by the letters "Cem" unless the area is congested and the legend cannot be placed within the cemetery limits, in such a case the cross symbol shall be used (See fig 5 35 and see **5416K** for names of cemeteries)

With the exception of churches only those buildings and mausoleums within the limits of a cemetery that are larger than 0 6 by 0 6 mm in size at manuscript scale shall be delineated

Principal entrances and exits in large cemeteries and the main roads connecting them shall be delineated All other roads shall be omitted

#### B FAIRGROUNDS, GOLF COURSES, RACE TRACKS, BALL PARKS, STADIUMS, ZOOS, ETC

The larger of these features shall generally be mapped and their limits shall be delineated on all manuscripts by dashed lines in black permanent plastic ink, according to figure 5 35 However, small features of this nature, such as tennis courts, baseball diamonds, football fields, driving ranges, and other small athletic fields and courts, shall be omitted

Permanent buildings and structures within the limits of these features shall be delineated in accordance with class I and class II buildings and structures (see **5446**) except that buildings other than dwellings smaller than 0 6 by 0 6 mm at manuscript scale shall be omitted The actual shapes of race tracks and tracks within stadiums shall be delineated

Principal entrances and exits shall be indicated Roads inside these features shall be omitted unless they are main roads traversing the feature

### 545 DELINEATION OF BOUNDARIES

A *boundary line* is a line along which two areas meet—the two areas having been distinguished at some time in their history by separate legal descriptions

In specific cases the word *boundary* is sometimes omitted, as in *State line*, sometimes the word *line* is omitted, as in *International boundary*, *county boundary*, etc The term *boundary line* is usually applied to boundaries between political territories, as the *State*

*boundary* line between two States, the *county boundary line* between two counties, etc. A boundary line between privately owned parcels of land is termed a *property line* by preference, or if a line of the United States public land surveys, it is given the particular designation of that survey system, as *section line*, *township line*, etc.

A *boundary monument* is a material object placed on or near a boundary line to preserve and identify the location of the boundary line on the ground.

The boundary lines of political divisions and subdivisions, United States public land surveys, and National and State reservations and sanctuaries shall be delineated on planimetric and topographic manuscripts.

The visible limits of certain features, such as airports, race tracks, and fairgrounds, shall be mapped on all manuscripts as specified in 5454. These limits are not legal boundaries, nor shall legal boundaries be delineated for the features discussed in 5454.

Boundaries and public land lines shall be delineated in *red* permanent plastic ink. The limits of features discussed in 5454 shall be delineated in *black* permanent plastic ink (see figs. 5 43 and 5 44).

Political boundaries, except National and State boundaries, and public land lines shall not be delineated on shoreline manuscripts. The limits of the features discussed in 5454 shall be delineated on shoreline manuscripts in black permanent plastic ink in accordance with figure 5 43. Boundary monuments that are recovered and identified by field parties within the limits of shoreline manuscripts shall be shown. In general, field parties will endeavor to recover State or national boundary monuments for shoreline surveys, but the recovery of other boundary monuments will be incidental.

The photogrammetric field party will obtain the legal descriptions of boundaries and will recover and identify boundary monuments and other marks on the field photographs. Where necessary for clarity, the field party will ink the actual boundary lines on the field photographs. Boundaries are generally recovered and identified by a special unit, and the data are submitted for a project or part of a project rather than for individual maps.

Horizontal accuracy requirements specify that not more than 10 percent of well-defined points shall be in error by more than 1/50 of an inch (40 feet on the ground) for maps published at scales of 1:20,000 or smaller. Recovered boundary monuments, original or accepted public-land survey corners, as well as boundaries or section lines that are marked by fences, roads, etc., are well-defined points and shall comply with these requirements.

#### 5451 Political Boundaries

The political boundaries to be mapped are national boundaries, State boundaries, county and parish boundaries, the first or major subdivision of the county or parish, and incorporated city limits.

Where a county or parish is subdivided into smaller political subdivisions, the boundaries of the first major subdivisions will be recovered and identified by the field parties and shall be mapped, but boundaries of any smaller subdivisions below the first subdivision, such as voting precincts or other political subdivisions, shall not be mapped.

Subdivisions of incorporated cities and towns shall not be mapped.

The field party will obtain from local and State governments the legal descriptions of political boundaries including descriptions of subsequent alterations in the original boundaries, and/or copies of official surveys or maps. Using these descriptions and surveys or maps the field party will identify boundary monuments and other pertinent marks on the field photographs, and will ink the boundary lines on the field photographs where this is necessary for clarity. Many boundaries originally were poorly described and/or marked,

and others have been wholly or partially obliterated by natural or cultural changes so that their accurate recovery and identification, or location, is extremely difficult. Consequently, the official description often has to be supplemented by information obtained from inhabitants of the area and by official signs marking the intersection of boundaries with the highways, though it must be recognized that the signs are often placed in accordance with highway maintenance and do not mark the boundary exactly. The field report on boundaries will discuss the field recovery and location in detail, and will indicate the probable accuracy of location of each boundary. The field party will locate boundaries as completely and accurately as the available information permits.

In delineating boundaries the office photogrammetrist shall study the field reports and the official descriptions to ascertain the completeness and accuracy of location. Boundaries between political divisions should be checked with the official description of each subdivision. Discrepancies in the descriptions of common boundaries are often found. It will generally be practicable to delineate the boundaries directly from the data shown on the field photographs, but, if practicable, the boundaries shall also be plotted from the official descriptions as a check against the field identification and recovery. A boundary which cannot be mapped with reasonable accuracy shall be identified with the legend "Approximate." Boundary lines not recovered and identified by the field inspection shall be referred to the field editor for identification.

Authentic boundary marks on the ground take precedence over written descriptions. Where a boundary line as located from the field identification disagrees in azimuth or distance with the official description, the boundary shall be mapped as marked on the ground, and thus shown in its actual position regardless of what the description calls for. In such instances, if it appears that the photogrammetric field survey may have made errors in the recovery and identification of the monuments or other marks, the boundary shall be referred to the field editor for further investigation.

Some political boundaries are defined by statute to follow natural features, such as streams or the divides between drainage basins. Those following bays, large rivers, etc., should be given special attention, as they may be defined as following the middle of the stream, its main current, or one of the banks.

Each boundary monument identified on the field photographs that has not been located in geographic position by ground survey methods shall be located as a photogrammetric station and shall be indicated by an open square 2 by 2 mm with the designating number placed alongside. The symbol shall be oriented with one side parallel to the direction of the boundary line. At boundary corners one side of the square may be parallel to either of the boundary lines. Boundary monuments that are located by triangulation shall be symbolized as triangulation stations.

Where two or more boundaries are coincident, the one of major importance shall be the one delineated. The following is the order of priority of political subdivisions:

- (1) National
- (2) State
- (3) County or parish
- (4) Major county subdivisions
- (5) Corporate limits

The names of political divisions ordinarily shall be shown within the limits of the divisions. If this is not practicable because of congestion of details, names may be placed outside the boundary, but each must be placed so as to indicate without ambiguity the division.

to which it applies. The names may be repeated in freehand lettering approximately 6-point in size along the boundaries wherever necessary for clarity.

#### 5452 *Reservation Boundaries*

A *reservation* is a tract of public land reserved for some special use, as for forests, Indians, national and State parks, or military or naval use.

The reservation boundaries to be mapped include the boundaries of national and State reservations, such as national forests, national parks, national monuments, Indian reservations, Coast Guard reservations, military reservations, naval reservations, bird and wildlife sanctuaries, State forests, and large State parks.

The same procedures shall be followed in mapping reservation boundaries as are followed in mapping political boundaries (see 5451).

Where two or more boundaries are coincident, the one of major importance shall be the one delineated. Reservation boundaries follow political boundaries in the following order of priority:

- (6) National reservations as bird and game reservations, forests, Indian reservations, monuments, and parks
- (7) State reservations as forests, monuments, and parks
- (8) Military reservations

The name of a reservation shall be shown within the limits of the reservation, if this is not practicable because of the congestion of detail, the name may be placed outside the boundary, but so that it indicates without ambiguity the reservation to which it applies.

#### 5453 *Public Land Surveys*

Public land surveys, instituted by the Federal Government, are rectangular surveying systems by which public land is subdivided or "sectionized" by the Bureau of Land Management (formerly known as the General Land Office). This subdivision is generally done before settlement of the land and is the basis for legal description of any part of the public land when referred to in legislation, proclamations, orders, patents (grants under "homestead" claims or other alienation of the public land), etc.

The description of public land surveys and the instructions for mapping public land lines contained in this manual are based on information in the Manual of Surveying Instructions, 1947, of the Bureau of Land Management, and the experience of the Geological Survey in mapping land lines as expressed in Geological Survey Bulletin 788, Section E and Technical Memorandum No. 67-1 of December 6, 1948.

#### A GENERAL INFORMATION

The system does not apply to the area of the thirteen original States<sup>3</sup>, nor does it apply to Maine, Vermont, Tennessee, Kentucky, and Texas. The surveys have not been completed in all the "public land" States, nor are they necessarily continuous throughout any given area.

The public land survey States where the surveys have been completed or almost completed are

Alabama	Iowa	Mississippi	Oklahoma
Arkansas	Kansas	Missouri	South Dakota
Florida	Louisiana	Nebraska	Wisconsin
Illinois	Michigan	North Dakota	
Indiana	Minnesota	Ohio	

<sup>3</sup> West Virginia was originally a part of the colony of Virginia.

Public land surveys are incomplete in the following States

Arizona	Idaho	New Mexico	Washington
California	Montana	Oregon	Wyoming
Colorado	Nevada	Utah	Territory of Alaska

The regional and public survey offices of the "public land" States along the coast from which information may be obtained are

Alabama	Secretary of State, Montgomery
California	Public Survey Office, Glendale Regional Office, San Francisco
Florida	Commissioner of Agriculture, Tallahassee
Louisiana	Register of State Lands, Baton Rouge
Mississippi	Commissioner of State Lands, Jackson
Oregon	Regional Office, Portland
Washington	Public Survey Office, Olympia
Territory of Alaska	Public Survey Office, Juneau Regional Office, Anchorage

### B A BRIEF HISTORY OF PUBLIC LAND SURVEYS

The first law governing public land surveys was enacted in 1785. That part of the Northwest Territory which became the State of Ohio was the experimental area for the development of the rectangular system, here the plans and methods were tested in a practical way. The original intent was to establish townships exactly 6 miles square, these to be divided into 36 sections, each of which was to be exactly 1 mile square. No allowance was made for the curvature of the earth and numerous complexities resulted. Successive revisions of the rules were made by acts of Congress as the surveys progressed westward. The culmination of these successive changes is the present system.

The adoption of the rectangular system marked the important transition from the surveying practices that prevailed in most of the colonial states where the land grants were defined by irregular metes-and-bounds, each depending more or less on the descriptions of the adjoining tracts known by name or survey number and mostly without common geographic location other than by reference to some well-known physical object.

Early public land surveys were made under changing systems and were generally made by contractors who used crude instruments and often worked under unfavorable field conditions. Consequently, the lines and corners are often in other than their theoretical positions. To eliminate litigation and avoid costly resurveys, the original corners as established on the ground legally stand as the true corners regardless of any irregularities in the original surveys.

Public land surveys cannot be properly mapped unless the personnel in the field and the photographic office charged with this work are familiar with the legal requirements concerning the layout and subdivision of public lands. The field parties cannot hope to recover corners and lines without a full understanding of the record concerning their original establishment nor can either the field or office personnel hope to map these surveys correctly until they have mastered the principles observed in the execution of the original surveys.

### C THE PUBLIC LAND SURVEY SYSTEM

The following discussion is intended to give a general outline of the plans and practices of the public land surveys.

All public land measurements are expressed in chains and links. A chain of 100 links is equivalent to 66 feet, and 80 chains equal one statute mile.

#### a General Information

The unit of the system is the *township*, a tract of land approximately 6 miles square. It is bounded on the east and west by true north-south lines (*meridians* referred to as *range lines*) and on the north and south by true east-west lines (*parallels* of latitude referred to as *township lines*). The township is divided into 36 *sections*, each approximately 1 mile square. The boundaries of a section are known as *section lines*.

Meridians (east and west limits of a township) converge northward to the pole, thus the width of a township decreased progressively from the south to north, the shape of a township is therefore trapezoidal, not square.



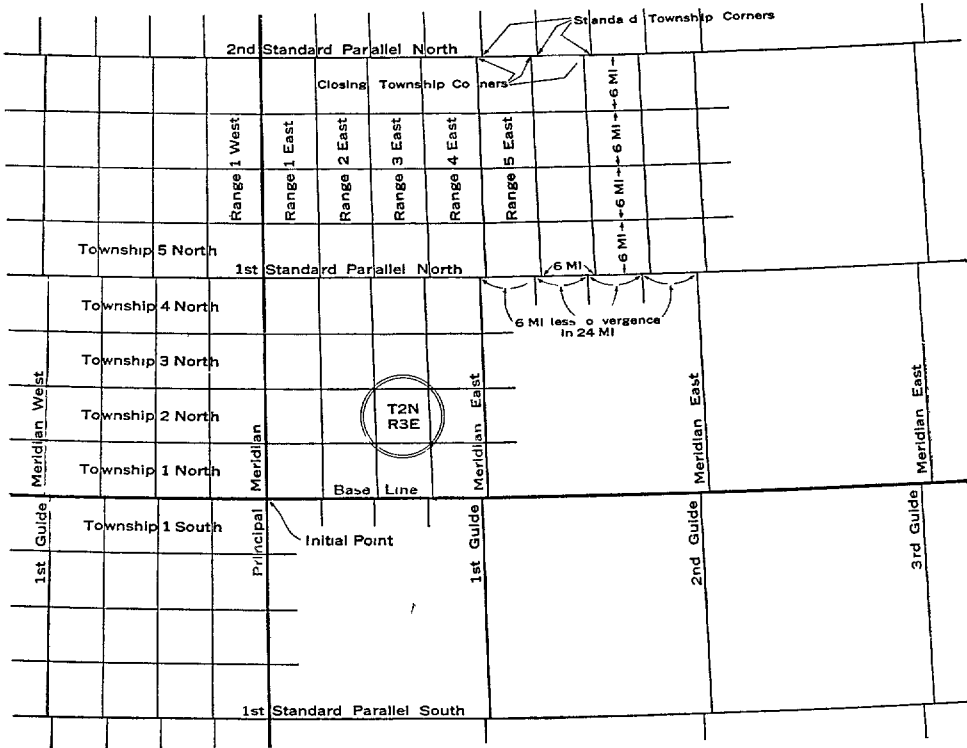

FIGURE 5 10—The subdivision of 24 mile tracts into townships

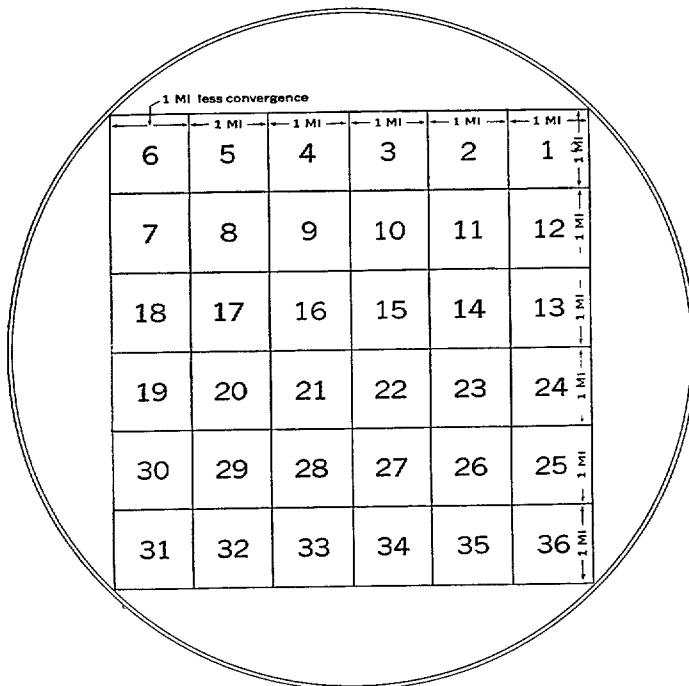

FIGURE 5 10a—Diagram of a township illustrating the method of numbering sections

In order to maintain townships as close to 6 miles square as possible the following described method of surveying has been evolved whereby systematic adjustments are made to achieve this close approximation

The township layouts are based on two *primary lines*—a *principal meridian* and a *base line* passing through an initial point. The *principal meridian* is a true north-south line (a meridian) extending both north and south of the initial point and the *base line* is a true east-west line (a parallel of latitude) extending both east and west of the initial point. These two lines constitute the axes of a system and the *initial point* constitutes the origin of that system. Many initial points were determined in the past by astronomical observations. There are now 34 systems in the United States and Alaska—each with a different principal meridian. Each principal meridian is known by a name or number which is used as a reference for any subdivision of the system.

The principal meridian is marked on the ground as a straight line, but the base line is a curved line coincident with a geographic parallel of latitude which at every point is at right angles to the meridian through that point.

### b 24-Mile Tracts

The area to be surveyed is first divided into tracts approximately 24 miles square.

*Standard parallels* (auxiliary base lines or correction lines) are extended to the east and west of the principal meridian at intervals of 24 miles north and south of the base line. Standard parallels are numbered with reference to the base line, as, for example, "Second Standard Parallel North" or "Third Standard Parallel South."

Guide meridians (true) are run *due north* at 24-mile intervals along the base line and standard parallels. Each guide meridian starts from a standard corner on the base line or on a standard parallel and ends at a closing corner on the next standard parallel (or the base line) to the north. Standard parallels are never crossed by guide meridians.

The tracts are 24 miles wide at their southern boundaries but, because the guide meridians converge, they are less than 24 miles wide at their northern boundaries. Consequently there are two sets of corners along each standard parallel—one set (standard corners) referring to the guide meridian north of the parallel and the other set (closing corners) less than 24 miles apart established by the guide meridians from the south closing on that parallel. (See fig 510.)

Guide meridians are numbered with reference to the principal meridian, as "First Guide Meridian East" or "First Guide Meridian West."

The standard distance of 24 miles between parallels and meridians is not always strictly adhered to. Thus, in many parts of the far West there are five tiers of townships (30 miles) between standard parallels and six, seven, or more ranges between guide meridians. In some places these irregularities in the spacing of the standard lines necessitate the introduction of intermediate meridians and parallels. These are designated by local names.

The offsets of the guide meridians on the standard parallels and their closing distances are of special importance, and the photogrammetrist should not fail to procure these data from the Bureau of Land Management and use them in plotting the guide meridians and standard parallels.

The meridional convergence increases proportionately to the distance from the principal meridian. Therefore the offset of the second guide meridian is double that of the first guide meridian (between the same parallels), that of the third guide meridian is three times as great and so on in proportion (the intervals being assumed to be regular). Again, the convergence increases slightly northward with the latitude. Thus the offset of a first guide meridian in latitude 50° is more than double what it is in latitude 30°. Of course the actual offsets depart somewhat from the theoretical offsets because of inaccuracies in surveying, and this makes it all the more imperative that they be noted on the plats.

It is to be borne in mind that all errors of closure in distance are deliberately placed in the last mile and are not distributed over the entire length of the line, the spacing of the corners along the line is thus not affected by the amount of the closure.

### c Townships

The 24-mile tracts are divided into *townships*, each approximately 6 miles square by *range lines* and *township (tier) lines*.

*Range lines* are laid out as true meridians at intervals of 6 miles along each standard parallel and are *extended north* to the next standard parallel. They start from standard corners placed at 6-mile

intervals by measurement along the standard parallels, and close at closing corners at their intersection with the next standard parallel to the north. Closing corners should theoretically be found at intervals of 6 miles less meridional convergence in the distance between standard parallels. The actual corners are usually not found at this theoretical spacing because errors in surveying procedure are not adjusted and the closing corners are placed where the line actually intersected in the original field survey.

*Township (tier) lines* (true parallels) join township corners at intervals of 6 miles on the principal meridian guide meridians and range lines.

Wherever practicable, the survey of townships within the 24-mile tract bounded by standard lines begins with the southwest township and continues northward until the entire west range is completed, then it goes from south to north through the next range east, etc. The procedure is to run first the east boundary of a township due north a full 6 miles, then to run its north boundary on a random or trial line from east to west, correcting back on a true line after the "falling" north or south of the north-west township corner has been determined. The closure in distance however is thrown in the last half mile at the west end of the line—that is, between the last quarter-section corner and the township corner. The result of this is to throw the meridional convergence and all irregularities arising from inaccurate surveying toward the west boundary of the township. The last quarter-section corner accordingly lies not midway in the last mile but always an even 40 chains from the mile corner east of it, whatever the distance between it and the township corner may be.

In using data to plot townships, therefore, special note should be made of the closing distances at the west ends of the latitudinal township boundaries. The accuracy of the surveys may be gauged from a comparison of the actual with the theoretical closing distances as indicated below.

<i>Latitude</i>	<i>Closing distance</i>	
	<i>Chains</i>	<i>Feet</i>
30° -----	79 58	5 252
35° -----	79 49	5 246
40° -----	79 39	5 240
45° -----	79 27	5 232
50° -----	79 14	5 223

In the northernmost tier of townships in a 24-mile tract it is further necessary to take note of the closing distances of the range lines on the standard parallel. Theoretically these distances should be as shown in the above table, but inaccuracies in the azimuth of the standard lines on the one hand and of the township lines on the other hand usually cause discrepancies. It frequently happened that the length of chain used for the one set of lines differed appreciably from that used for the other, and the closure errors may be rather large.

Townships are usually numbered with reference to the primary lines in consecutive rows (called townships) to the north and to the south beginning at the base line, and in consecutive columns (called ranges) to the east and to the west beginning at the principal meridian. Any township may be designated by its principal meridian, township and range numbers as

T3N, R2W, Tallahassee Principal Meridian

T4S, R5E, Tallahassee Principal Meridian

#### *d* Townships Subdivided into Sections

The law provides that the townships shall be subdivided into sections containing as nearly as practicable 640 acres each and that "the excess or deficiency shall be specially noted and added to or deducted from the western and northern ranges of sections or half sections in such townships, according as the error may be in running the lines from east to west or from south to north."

The south and east boundaries are normally the governing lines of subdivisional surveys.

The sections are formed by straight lines run parallel to the eastern range lines 1 mile apart and by straight east-west lines run parallel to the south township line 1 mile apart.

In the plan of subdivision of all normal townships the meridional section lines are established parallel to the east boundary or other governing line, beginning with the southeast section. This necessitates a slight correction because of the angular convergency of meridians. Meridional section lines west of the governing line are deflected to the left of the bearing of the governing line by the amount shown in

the second part of Table 2, Standard Field Tables, Bureau of Land Management, which is entered under two arguments (1) latitude and (2) distance from the governing line. Meridional section lines east of a governing boundary are given the same amount of correction for bearing, but the deflection is made to the right. The west boundary is measured a full 80 chains, its north boundary is then run east on a random or trial line, a quarter-section corner being temporarily placed at 40 chains. The "falling" north or south from the appropriate corner of the township boundary having been measured, the quarter-section corner is then shifted proportionately and set exactly midway between the section corners. In many of the older contracts these rules were not faithfully carried out, and, as a consequence, little dependence is to be placed on the position of the quarter-section corners of the latitudinal section lines. The west boundary of the next section north is then run out, and then its north boundary as before and so on through the entire east range of sections. The other ranges are taken up consecutively from east to west, each being surveyed from south to north. The range lines of the northernmost tier differ from the others in that they are connected with the corners along the township boundary and consequently are not always parallel to the east boundary nor do they measure an even 80 chains in length. Theoretically they should do so but in practice the inaccuracies in the surveying of the township exteriors on the one hand and of the section lines on the other hand, cause discrepancies. Accordingly, these lines are run first on a random or trial line parallel to the east boundary and then corrected back according to their "falling." In order to confine the irregularities in acreage to the northernmost tier of lots the excess or deficiency in measurement is thrown north of the quarter-section corner, which is consequently set not midway but an even 40 chains from the south end of the line.

In the west range of sections, again, the latitudinal lines are connected to corners along the west township boundary. Each is therefore run first on a random parallel to the south boundary of the section and then corrected back according to its "falling." Here again, in order to confine the irregularities in acreage to the westernmost range of lots the error (which normally is a deficiency equal to the meridional convergence) is thrown west of the quarter-section corner which is consequently set not midway but an even 40 chains from the east end of the line. (See fig 5 10)

### e Meander Lines

All navigable bodies of water and other important rivers and lakes are segregated from the public lands at mean high water elevation. The traverse of a margin of a permanent natural body of water is termed a *meander line*. In original surveys, meander lines are not run as boundary lines but for the purpose of defining the sinuities of the bank or shoreline and for ascertaining the quantity of land remaining after segregation of the water area.

Meander lines shall not be delineated on map manuscripts but meander corners shall be shown when recovered.

### f Land Grants, Claims, and Reservations

As previously stated, territories acquired by the Federal Government became public lands with certain exceptions. These exceptions were tracts of land title to which had been granted by a preceding sovereign authority to individuals, groups, or institutions prior to the transfer to the Federal Government. If the validity of the title to these tracts was confirmed upon investigation, the tracts were surveyed by metes and bounds for exclusion from the area of public lands at the same time that contiguous areas were surveyed for subdivision by township range, and section lines. The boundaries of the excluded tracts are shown on the plats of the public lands and their areas are generally referred to as "land grants" or simply "grants." The boundaries of grants shall be mapped.

Official public-land surveys have been executed within the boundaries of some grants as is evidenced by approved plats and field notes of the General Land office or the Bureau of Land Management. In such cases, it must be assumed that the title to the grant was not authenticated until some time subsequent to the execution of the original surveys. Such subdivisional surveys are official although they have no legal status as public-land surveys, because the authentication of title to a grant definitely excluded its area from public ownership and other disposal by the Federal Government. However the established corners and their connecting lines exist on the ground. In some cases, the owners of the grants apparently used such Land Office subdivisions for disposing of parcels of land within their tracts. This is evidenced by roads and fences following the subdivisions within a grant. In such cases, the sub-

divisions established by the public-land surveys shall be mapped as useful cultural information. Within other such grants, the roads and fences may have no relation to the corners and lines established by the subdivisional surveys, indicating that no use has been made of the subdivisions by the owners of the grants. In such cases no useful purpose is served by showing the pattern of the subdivisions and they should not be shown within the grant boundary.

In some cases large land grants have subsequently been subdivided by State, county, or private surveyors in general accord with the pattern and practice of the Federal public-land surveys. Such subdivisional corners and lines shall usually be omitted from quadrangle maps because they are not part of the public-land survey system. In exceptional cases where for some outstanding reason it appears desirable to show such subdivisions a full explanation shall be made to the Washington Office and a decision requested. If mapped, the lines of such subdivisions shall be shown by the dotted-line symbol and the map shall carry a marginal note calling attention to the unusual treatment.

Title to other irregular tracts such as mineral small-holding, and forest-entry claims, and homestead claims in Alaska has been transferred by the United States prior to the subdivision surveys. Also prior to these surveys, reservations have been established, such as the various Indian, military and lighthouse reservations, and national parks and monuments. These tracts were and are treated in the same manner as grants in the subdivision surveys, and their boundaries shall be shown by the appropriate symbols.

Grants, claims and reservations are frequently irregular in outline. Since they constitute a prior claim and are excluded from the public lands, they materially affect the pattern of the adjacent land-line network.

The procedure in the survey of the public lands is similar for the establishment of the boundaries of each type of grant, claim or reservation and the exclusion of their areas. Monuments are specified for each angle point of the tract boundary and are given serial numbers beginning with No. 1 at the initial point. Also, if the length of any course exceeds 45 chains, additional monuments are specified to be set so that no monument shall be more than 45 chains from another. Witness points are sometimes set at the intersection of the boundary line with roads, trails, streams, and other natural features, and in the survey of large grants or reservations, mile corners in addition to the angle-point monuments and the witness points are specified.

Land grants are usually identified on the land-office plats by number or name. The identification and location on the ground of the boundaries of grants, claims, and reservations is often difficult. The field engineer must have copies of all of the plats of the public-land surveys of his area including any plats or notes of dependent or independent resurveys and supplemental surveys which may modify or supersede the original surveys and plats.

The boundaries of existing reservations shall be shown by the appropriate symbol. In some cases, reservations in existence when original public-land surveys were made have since been abandoned or their boundaries changed. The land involved reverts to public-land status, and may have been subdivided later. In these cases the location of the old boundary and of the section lines established within it are shown by the section-line symbol.

#### D MAPPING OF PUBLIC-LAND SURVEY DATA

The following survey data for public-land surveys made under the jurisdiction of the Bureau of Land Management shall be shown on planimetric and topographic maps, but shall not be shown on shoreline surveys unless specifically required by the project instructions:

(a) The location and classification of all section corners that can be found by a reasonably diligent search and all quarter-section witness, and meander corners that are identified.

(b) The location and classification of all township section, and grant lines that have been run and approved by the Land Office and are not under suspension.

The project instructions will state when public-land survey data are to be mapped, and the Washington Office will either furnish the field party with the necessary plats and descriptions obtained from the Washington Office of the Bureau of Land Management or the Officer-in-Charge will request this information from the State or regional office.

### a Definitions

The following definitions are pertinent to the mapping of public-land survey data

(1) An *original corner*, or *true corner* is defined as one where the original or officially re-established monument or mark is found or its location is definitely identified by one or more original reference marks, and which agrees with the description given in the field notes or as indicated on the plats of the official survey

(2) An *accepted corner* is one which is accepted and used but for which the original markings cannot be recovered. Corners marked by pine knots, stakes, unmarked monuments, blazed trees, fence corners, mounds, etc. accepted as the correct location for the corner but which, because of the elapsed time since the original Land Office survey, could not be the original marking, fall in this class of corner.

Both true and accepted corners shall be shown on the published maps by the approved corner symbol, except where they are located in a road.

(3) A *theoretical corner* is one which has not been recovered on the ground but which has been plotted on the manuscript from land plat measurements.

### b Field Surveys

Photogrammetric field surveys made prior to the manuscript compilation will include the recovery and identification of original and accepted corners, and the identification of other ground details which indicate the positions of land lines. Where field investigation shows that the public land system in any part of the project has been resurveyed and remonumented by State or local authority and these resurveys are not recorded on the Bureau of Land Management plats, the Officer-in-Charge shall request information from the State or regional registrar of public land records (see 5453A) as to whether the resurveys shall be mapped in lieu of the original surveys. If the question is not decided by such correspondence the Officer-in-Charge shall refer the matter to the Washington Office for decision.

The field work will generally be on a project or partial project basis involving a number of maps. The identified details will be shown on the field photographs, but these will be accompanied by the Bureau of Land Management plats and notes, copies of local maps or survey notes, and identification cards. These data will be accompanied by a report, either a special report or section of the field inspection report, on the field work relative to public land lines. (See 714 and 724)

The data submitted by the field party may be conveniently itemized as follows:

- (a) The recovery and identification of original land corners
- (b) The recovery and identification of accepted land corners
- (c) The identification of cultural and natural features common to land lines or land corners, or referenced to land lines and land corners. The identification of these details will have been accomplished from local survey records to assist in applying the land lines as shown on the plats to the manuscripts. This information will be less positive and authoritative than the recovery and identification of original and accepted corners and must be used with more discretion in the photogrammetric office.
- (d) A detailed description of field work relative to public land lines and corners.

### c Delineation of Section Corners and Township Corners

Section corners and township corners and the numbering of sections shall be delineated as follows:



FIGURE 5 11—An original corner



FIGURE 5 12—An accepted corner

(a) The symbol for an *original* or *true corner* shall be either a small vertical cross representing the cross lines where four lines intersect or a "T" where three lines intersect. The symbol shall be enclosed by a 20 mm square, regardless of which symbol is used (see fig 5 11)

(b) The symbol for an *accepted corner* shall be the same as for an original or true corner except that it shall be enclosed by a 20 mm circle (see fig 5 12)

(c) No symbol shall be shown for a *theoretical corner* other than the crossing of the section lines (see fig 5 44)

(d) *Subsection corners* or *meander corners* recovered by the field party shall be plotted on the manuscript. They shall be symbolized in the same manner as section corners.

(e) Section numbers in 6-point vertical figures shall be placed in the corners of the sections adjacent to the corner symbol (see fig 5 13)

#### d Delineation of Land Lines

The relative strength or weakness of the land net depends on the proportion of recovered corners to corners not recovered as well as on the number of section lines marked by fences, roads and other cultural features.

It is the objective of the field surveys to recover a sufficient number of corners and lines to justify mapping public-land lines as reliable lines.

Recovered original or true corners and accepted corners, as well as section lines that are marked by fences, roads, etc, are well-defined and should comply with accuracy requirements for well-defined points.

Land lines shall be shown as reliable where they have been located or identified on photographs in the field or where they connect true or accepted corners that have been located or identified in the field. Land lines that are not so located and that are not defined by fences and/or roads perhaps cannot be strictly considered as well-defined, nevertheless, land lines that are a reasonably accurate reconstruction of the land net and that are believed to be in correct position on the map within the specified tolerance shall be accepted as *reliable* land lines and shall be delineated as illustrated in figure 5 44. Land lines shall be considered reliable if based on

(1) The recovery of a sufficient number of true corners or accepted corners.

(2) A satisfactory number of roads, fence lines, ditches, and similar property lines that serve as visible evidence of the position of land lines.

(3) The reconcilability of Bureau of Land Management survey notes with the topography and actual ground distances.

(d) Fifty percent or more of the line crossings of natural and cultural features as shown on the plat closely agreeing with the same crossings of the corresponding lines on the manuscript.

Land lines of a highly questionable reconstruction of the land net are classed as *unreliable* and shall be delineated as illustrated in figure 5 44. A land line net is unreliable if

(1) Few or no true or accepted corners were recovered.

(2) Little or no visible evidence of the location of section lines (roads, fence lines, ditches, and similar property lines) exists.

(3) Bureau of Land Management survey notes are irreconcilable with the topography and actual ground distances.

(4) Less than 20 to 50 percent of the line crossings of natural and cultural features as shown on the plat closely agree with the same crossings of the corresponding lines on the manuscript.

At the discretion of the Officer-in-Charge land lines may be omitted from whole or fractional townships where more than 80 percent of the line crossings of natural and cultural features as shown on the plat disagree with the same crossings on the manuscript. In this case an appropriate marginal note, on both the manuscript and the published map, shall

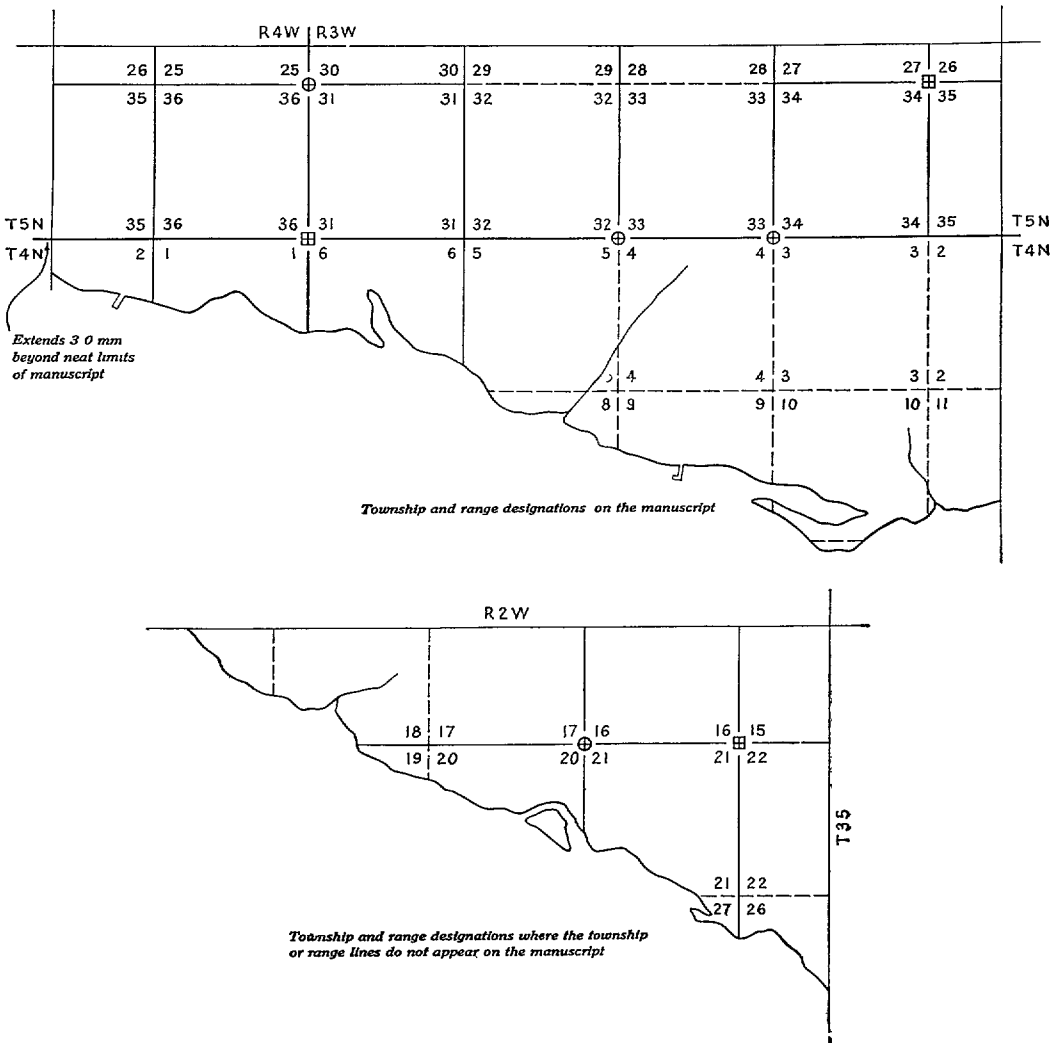

FIGURE 5 13 —Township and range designations

call attention to and explain the intentional omission. Conversely, the lines in such whole or fractional townships may be shown as unreliable at the discretion of the Officer-in-Charge, if in his opinion the disagreements between the line crossings of natural and cultural features as shown on the plat and on the map will not serve to discredit other details on the map.

Land lines shall be plotted or delineated on the manuscript after all other natural and cultural features have been delineated, including the location by photogrammetric methods of the original and accepted corners. The delineation of land lines will then be done as follows:

(a) The land lines as shown on the plats are drawn on tracing paper, tracing cloth, or some other transparent medium at the scale of the manuscript. A drafting machine or parallel arm is very convenient in making this drawing, and should be requisitioned from the Washington Office if one is not available in the photogrammetric office.

(b) The tracing described in (a) is then fitted to the manuscript by holding to the available original and accepted corners and/or lines located in the field, or identified accepted lines marked by roads.



ditches, fences hedges or crop boundaries, or where good agreement can be attained between natural and cultural features as recorded on the plats and in the field notes with corresponding features shown on the manuscript. After the best possible agreement, the land lines are copied from the tracing to the manuscript.

(c) The photogrammetrist must delineate the land lines *as they exist on the ground*. Assuming the positive recovery of a number of original or accepted corners in an area this is relatively simple where the original land survey has been made accurately. Unfortunately this is not always the case, and frequently lines shown as straight lines on the plats are not straight on the ground nor do they always follow the course indicated on the plats. Consequently, in plotting the land lines between original and accepted corners the photogrammetrist must study the supporting cultural and natural features as stated previously and must be alert to discover deviations of the actual lines from the plats. *However, the lines must be plotted between recovered and accepted corners as indicated on the plats unless other evidence supplied by the field party and the photographs is quite conclusive.*

(d) Where an additional effort to recover additional corners is necessary or desirable the matter shall be referred to the field-edit party and that section of the land line compilation left temporarily incomplete. After the field edit the delineation of the land lines shall be completed in the photogrammetric office.

(e) Only those public land monuments and lines approved by the Bureau of Land Management as evidenced by the plats shall be mapped.

(f) Land lines shall be delineated in the same manner on planimetric and topographic manuscripts in red permanent plastic ink.

(g) Township and range numbers shall be placed along the lines bounding the townships—the township numbers along the east and west limits and the range numbers along the north and south limits. If only a part of a township appears on a manuscript, the township and range numbers shall be placed along the outside limits of the manuscript. Township, range, and section numbers shall be in red permanent plastic ink. (See fig 5 13.)

(h) Numbers and names of base lines and principal meridians shall be shown on the manuscripts on which they appear.

(i) Land lines dividing sections into fractions shall not be delineated.

(j) Land lines broken at the shores of water bodies or at meander lines on the Bureau of Land Management plats shall be similarly broken on the manuscripts. They shall not be drawn across a meandered water body.

(k) Land lines shall be omitted where coincident with roads, ditches, railroads, and similar features. Land lines that are omitted shall be indicated by a note which shall include information as to whether the land line is reliable or unreliable. This information shall also be included in the Descriptive Report.

(l) Where the shoreline has changed, land lines shall be shown on the manuscript as they were originally established continuing as the case may be into or across the river, lake, or reservoir in a location that was a land area when the public land surveys were executed, except where it is evident that the original survey was erroneous.

#### 5454 *Limits of Airports, Cemeteries, Parks, etc*

The limits of airports, cemeteries, parks, playgrounds, fairgrounds, amusement parks, large public institutions, and similar features shall be delineated on all manuscripts where the delineation of the limits of such a feature will clarify or add to the value of the map, otherwise the limits of these features may be omitted. The limits of features discussed under this heading generally are apparent on the photographs or are apparent to the field inspector, who will indicate those of importance for the clarity of the map. Legal boundaries of these features are not required and shall not be mapped. (See 545 and fig 5 43.)

An airport, cemetery, park, playground, or similar feature is often so bounded by natural or physical features shown on the map that the symbolization of its limits would be superfluous. For example, where a park occupies an entire city block the limits are apparent without symbolization, and in many cases airports in developed areas have no apparent limits other than the roads, railroads, shoreline, or other features surrounding them. Where the limits are not indicated by map features it is often important that they be symbolized,

as in the case of a sod air field in any open area where there would be no indication on the map of its size or extent without symbolization of its limits, or in the case of a cemetery in an otherwise undeveloped area where its limits are necessary to indicate its extent

#### 546 DELINEATION OF CONTROL

The horizontal and vertical control stations that are to be shown on map manuscripts and the symbols for these stations are discussed under the several headings of this subject (see also 159)

The names and symbols of all horizontal stations shall be shown on *all three types* of map manuscripts unless otherwise stated herein and in black permanent plastic ink. Station names and symbols shall not obscure important map detail. Where space does not permit placing the name near the station, a reference number may be used and the name may be lettered in the margin or in a convenient open space on the manuscript. The station symbol may be broken where necessary as indicated in figure 5 43. See 5426, 5446A(1), and figure 5 43 for instructions regarding the delineation of detail within a control symbol.

Tidal bench marks are shown on all manuscripts, but without their elevations on planimetric and shoreline manuscripts, other vertical control stations are shown on topographic manuscripts only. Benchmarks and their elevations shall be shown in black permanent plastic ink.

#### 5461 Recoverable Horizontal Control Stations of Third-Order or Higher Accuracy

All recoverable horizontal control stations of third-order or higher accuracy<sup>4</sup> that are tied to the Federal net and which are in existence at the time of the field inspection—that is, all stations not reported lost after a thorough search—shall be shown on the manuscripts regardless of whether they are Coast and Geodetic Survey stations or stations of other agencies. The only exceptions permitted are stated in the following three paragraphs.

In rare instances where control stations are so numerous that the delineation of all would congest the manuscripts, the photogrammetrist, with the approval of the Officer-in-Charge of the photogrammetric office, may make a selection of stations to be shown. If such a selection is made, the omitted stations shall be designated on Form M-2388-12, which is included in each Descriptive Report.

Closely spaced stations of other agencies are also an exception—for example, where stations of the U S Engineer Corps in harbors, or where traverse stations, are so closely spaced as to congest the manuscript, about one station every 3 inches on the manuscript is sufficient and the others may be omitted. The selection of the stations to be shown on the manuscripts should be based on

- 1 Permanance
- 2 Prommence
- 3 Distribution

If no attempt has been made during field inspection to recover all triangulation stations, the stations to be shown on the manuscript shall be selected from recovery notes in accordance with the above instructions. All stations used to control the photographs shall be shown on the manuscripts.

<sup>4</sup> Stations of third order or higher accuracy include triangulation and traverse stations and those supplemental control stations located by special methods such as by three point fix or by intersection or other means when the method and observations are of at least third order accuracy (see 711)

A horizontal control station is classified as "lost" if the disk marking it is missing or has been disturbed in position and the disk cannot be replaced in its exact original position by check measurements from adjacent reference marks, where the station was a natural object, it is classified as "lost" if the original natural object has been destroyed, moved, rebuilt, or otherwise tampered with so as to discredit its geographic position. Such stations are classified as "lost" triangulation or traverse stations and are so reported on Form 526. Some such stations, however, may be recovered within close enough limits to be used to control the radial plot, in which case they are symbolized as recoverable horizontal control stations of less than third-order accuracy (see 5462). Examples are the monument is recovered at or near its original position although it has been moved, a church spire has been rebuilt on the original church in what is reported to be its original position, an aid to navigation has been rebuilt on the original foundation, the position of the chimney of a house that has burned can be determined from the foundation, etc.

A station reported as "not recovered" on Form 526 is not considered "lost" unless the recovery note shows conclusively that the station has been disturbed or destroyed. The fact that a station was not found is not in itself sufficient evidence to justify classifying it as "lost."

Recoverable horizontal control stations of third-order or higher accuracy shall be symbolized by an equilateral triangle 4.5 mm on a side symmetrically placed around the station point with the base of the triangle normal to the meridian and the apex of the triangle in a north direction. (See fig. 541.)

The station names and dates shall be lettered on the manuscript exactly as shown in the list of positions (Form 28B) except that the recovery dates shall be omitted. Where the station is a prominent object and this fact is not indicated in the station name, a descriptive name (taken from the field description) shall be shown, followed by the station name in parentheses. Where the station is an aid to navigation and the station name differs from the name in the Light List, the Light List name and/or number shall be shown, followed by the station name in parentheses (see fig. 543).

The agency designation shall be omitted for Coast and Geodetic Survey stations, but shall be shown by initials for stations established by other agencies.

#### 5462 Recoverable Horizontal Stations of Less Than Third-Order Accuracy

All recoverable horizontal stations of less than third-order accuracy<sup>5</sup> shall be symbolized by black circles 2.5 mm in diameter symmetrically placed around the station points (see fig. 541). These stations shall include marked stations and stations on prominent objects, such as landmarks and aids to navigation. (See also 5463 and 5464.)

The names and dates of these stations shall be shown exactly as listed on Form 524 except that recovery dates shall be omitted. Where a station is a prominent object and its station name is not descriptive, a descriptive name (taken from the field description) shall be shown, followed by the station name in parentheses. (In this case the descriptive name shall be added to Form 524 in red ink.)

#### 5463 Photo (Topo) Stations

Recoverable photo (topo) stations that have been located within 0.3 mm (0.012 inch) of the correct geographic position as *measured on the manuscript* and which are in exist-

<sup>5</sup> Recoverable stations of less than third order accuracy include ground and photogrammetric stations—that is stations located by traverse and triangulation methods but not meeting third order requirements such as (1) three point fixes and by intersection (2) a combination of traverse and triangulation and (3) planetable and (4) photogrammetric stations located by either radial plot or stereoscopic instruments.

ence at the time of the field inspection—that is, all newly established stations and all stations not reported lost or unrecovered after a thorough search—shall be delineated and shall be symbolized with 2.5 mm black circles. Fixed aids to navigation, landmarks, and azimuth marks that are located by photogrammetric methods are classed as photo stations.

Inaccuracies in the location of photo (topo) stations can occur in two different operations: (1) in the identification of the photographic images (see 4611) and (2) in the location of the photo (topo) stations by the radial plot. The resulting combined effect must not exceed 0.3 mm at the scale of the manuscript. The greater accuracy required in the location of photo (topo) stations is because they provide a basis for extending control for future revision surveys and because many of these stations are shown on published charts.

#### A FIXED AIDS TO NAVIGATION

The name or the number of each fixed aid to navigation should be checked against the latest issue of the Light List. Where the station name differs from the name in the Light List, the Light List name and/or number shall be shown followed by the station name in parentheses.

#### B LANDMARKS

No special notation is required or necessary on the manuscript to show that a station is a landmark and is to be charted. The fact that a station is a *landmark to be charted* is taken care of by the submittal of Form 567.

#### C AZIMUTH MARKS

Creation date  
 name as -  
 stamped on disc  
 Manual  
 other  
 mk  
 it is a  
 M  
 spelling  
 disk

Azimuth marks ordinarily are not located in geographic position by the triangulation. They are identified on the photographs by field inspection and shall be located by photogrammetric methods and shown on the manuscripts as photo stations. All the requirements for this class of station shall be met. Form 524 is required. No notation is necessary on the manuscript except the name, for example, if the triangulation station is named QUARRY, 1930, the name on the manuscript for the azimuth mark would be QUARRY AZ MK 1930. See No 474 Supplement Pungo River & Vicinity, N C Description of Triangulation Stations - Δ Yeatsville, R M 3 (AZ MK), p 13

#### 5464 Photo-Hydro Stations

Photo-hydro stations that have been selected by the field inspection party and that have been located within 0.5 mm of correct geographic position, or otherwise located as specified by the project instructions, shall be delineated on all manuscripts except as noted below.

Discrepancies in the location of photo-hydro stations (see 4612) are similar to those of photo (topo) stations except that the resulting combined effect must not exceed 0.5 mm at the scale of the manuscript.

Photo-hydro stations provide control for subsequent hydrographic surveys, however, they do not provide a basis for extending control nor are they shown on published charts or maps.

Photo-hydro points shall not be shown on a topographic manuscript when a shoreline survey is being made concurrently. Therefore, where a shoreline manuscript is being compiled and is to be reduced for the tracing of detail to a topographic manuscript the photo-

hydro points that appear on the shoreline manuscript shall not be transferred to the topographic manuscript

Photo-hydro stations shall be symbolized by circles 2.5 mm in diameter symmetrically placed around the station points (see fig 5 42)

These stations shall be shown on the manuscript identified with the reference number used by the field party and shown on the field photographs Each photo-hydro station shall be listed by number and described in the compilation report No descriptions of photo-hydro stations shall be shown on the manuscript nor shall an overlay be prepared to show the description Form 524 is not required for photo-hydro stations *Also see 4614(b) for numbering of stations.*

#### 5465 Substitute Stations

Substitute stations (see 4114) shall be symbolized by red permanent plastic ink circles 2.5 mm in diameter symmetrically placed around the station point (see fig 5 41)

The note "Sub Pt" is lettered in permanent red ink adjacent to the substitute station symbol on the manuscript The station name is used only where it is necessary to avoid confusion

These points will not be shown on the printed maps *-Removed during review*

#### 5466 Bench Marks

Bench marks existing at the time of photogrammetric field surveys—that is, bench marks not reported lost or unrecovered after a thorough search—shall be shown on topographic manuscripts These shall include bench marks of the Coast and Geodetic Survey and those of other organizations that are connected to the vertical control net Only tidal bench marks shall be shown on planimetric and shoreline manuscripts unless the project instructions state otherwise

Bench marks of other organizations that are not connected to the vertical control net of the Coast and Geodetic Survey but which are recovered and identified on the photographs in accordance with project instructions shall not be shown on the map manuscript unless specifically authorized by the project instructions

Bench marks shall be designated in accordance with their accuracy and method of location

(a) A *monumented bench mark* is a described point marked by a metal tablet whose elevation is of third-order accuracy or better

Monumented bench marks shall be symbolized by a 5 mm cross in black permanent plastic ink centered at the position of the bench mark and designated by the letters 'BM' The lines forming the cross shall be at 45° to the meridian (See fig 5 14)

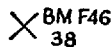

FIGURE 5 14—A monumented bench mark

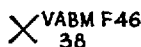

FIGURE 5 15—A monumented vertical angle bench mark

(b) A *monumented vertical angle bench mark* is a described point marked by a metal tablet whose elevation has been determined by reciprocal vertical angles

Monumented vertical angle bench marks shall be symbolized the same as monumented bench marks except they shall be designated by the letters "VABM" (see fig 5 15)

(c) A *non-monumented bench mark* (sometimes called a temporary supplementary or intermediate bench mark) is a described point not marked with a tablet but which is recoverable and whose elevation is of third-order accuracy or better. It may be marked by a chiseled cross, a nail and washer in the foot of a tree, etc.

Non-monumented bench marks shall be symbolized by the same type cross as a monumented bench mark, however, only the elevation shall be shown. (See fig 5 16)



FIGURE 5 16 —A non monumented bench mark

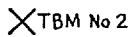

FIGURE 5 17 —Tidal bench marks

(d) A *tidal bench mark* is a described point usually marked by a metal tablet established in the vicinity of a tide station for the purpose of preserving tidal planes determined from the observations.

Tidal bench marks shall be shown on all manuscripts, but they shall be shown without elevations. The elevations of those tidal bench marks that have been connected to the Federal net and for which elevations above the Sea Level Datum of 1929 are available shall be shown on topographic manuscripts.

Only one of a group of two or more closely spaced tidal bench marks need be delineated. Where they are located with photo point accuracy, they shall be symbolized as photo points are, otherwise, they shall be symbolized as bench marks. (See fig 5 17)

Bench mark designations and elevations shall be shown in 6-point vertical lettering exactly as shown on Form 638 or 685 or in the published list except that the dates of establishment or recovery shall not be shown. The elevations shall be shown to the nearest foot, referred to the mean sea level datum. The agency designation shall be omitted from Coast and Geodetic Survey bench marks, but shall be shown by initials for bench marks established by other agencies.

### 5467 Spot Elevations

Spot elevations to be shown on topographic manuscripts are selected in accordance with **5432E**.

*Checked spot elevations* are elevations established by closed lines, including elevations determined by spirit level, stadia, and vertical angle methods.

*Unchecked spot elevations* are elevations determined by unchecked field surveys, such as side shots on stadia lines, unchecked vertical angles, and precise barometric leveling, and those elevations determined by repeated photogrammetric readings.

Spot elevations shall be shown in the following manner on topographic manuscripts (see fig 5 42)

(a) Where the spot elevation is for a well-defined point, such as a road intersection, no symbol shall be used.

(b) Where the spot elevation is for a poorly-defined point such as the top of a knoll or the low point of a depression, the position of the point shall be indicated by a 30 mm cross in brown permanent plastic ink with the lines at approximate 45° to the meridian. *Top elevs.*

(c) The elevation, to the nearest foot referred to the mean sea level datum shall be placed adjacent to the well defined point, or the symbol in 6-point inclined figures in black permanent plastic ink for checked spot elevations and in brown permanent plastic ink for unchecked spot elevations.

(d) *hacking cultural detail - distribute elevs thru areas*  
Photo elevation points are images of points whose elevations are determined by stereo-photogrammetric methods. They are read and recorded during the contouring. *36 ← brown ← under*

Photo elevation points shall be selected and delineated in the same manner as unchecked spot elevations

### 547 TIDE CORRECTIONS

A knowledge of the stage of the tide is necessary for the delineation of the shoreline and alongshore features, for the determination of the heights of rocks or shoals above the sounding datum or mean high water (see 5424), and for the determination of bridge clearances

The stage of tide at the time and date of the exposure of each photograph from which shoreline and alongshore features are delineated shall be determined with reference to the sounding datum of the area, referred to the nearest reference station or subordinate station for which tide predictions are available

Each rock or shoal for which field inspection information or stereo-photogrammetric height is furnished shall have its height determined with reference to either the sounding datum or mean high water as required by 5424C

It is required that the field party determine the vertical clearance of bridges above mean high water at the time of the field inspection. The vertical clearance with reference to the water level and the time and date are also recorded on the field photograph so that the tide correction may be applied by the office photogrammetrist and the vertical clearance above mean high water checked

For photogrammetric mapping of coastal areas, it would be most convenient to have two sets of photographs—one set taken at exactly mean high water and one set taken at exactly mean low water or mean lower low water. However, this is not economically feasible and the photographs are normally taken at any stage of the tide

#### 5471 Tide Computations

**Tide Tables** are published annually by the Coast and Geodetic Survey with all information necessary for tide corrections. Interpolated values from the Tide Tables are of sufficient accuracy for tide corrections of heights or elevations to the nearest whole foot

The predicted values of the tide may be determined by the procedure described in Special Publication No 143, Hydrographic Manual, heading 1521. A tide curve need be constructed *only* where elevations are to be determined for a considerable number of rocks. To determine the stage of tide for a few rocks, for a single photograph, for a single bridge, or for field inspection data at various dates, the method explained as follows, involving the use of Tables 1 to 3 of the Tide Tables, is more suitable and more convenient

The duration of rise or fall is determined from the difference between the time of high tide and the time of low tide which are obtained from Table 1 of the Tide Tables. The heights of high and low tide for subordinate stations are determined by multiplying the height of tide from Table 1 by the ratio of ranges from Table 2. The difference between these two heights of tide is the range of tide for the subordinate station. (See fig 5 18)

The corrected time is determined by adding algebraically the time difference as obtained from Table 2 to the time of tide as obtained from Table 1. The corrected time is used only when a subordinate station is used, that is, if the tide corrections are made for the reference station itself, there is no time difference and therefore no time correction

In finding the time interval, the required time is that recorded during field inspection. The time of high or low tide is the corrected time as previously computed. Either high or low tide is used, depending on which is closer to the required time

TIDE COMPUTATION

PROJECT NO Ph II T 8799

Time and date of exposure 1300 5 23 46 Reference station Eastport, Maine Mean range 12 3  
 Date of field inspection 7-17-46 Subordinate station Raque Island Harbor Ratio of ranges 0 7

	Time h m		Height feet	Height x Ratio of ranges		Time h m		Time h m
High tide	12 54	High tide	17 2	12 0	High tide at Ref Sta	12 54	Low tide at Ref Sta	6 53
Low tide	6 53	Low tide	-0 2	-0 1	Time difference	-0 15	Time difference	-0 15
Duration of rise or fall	6 01	Range of tide		12 1	Corrected time at Subordinate station	12 39	Corrected time at Subordinate station	6 38

	h m		feet		feet	Photo No
Time H T or L T Required time Interval	12 39 9 45 2 54	Ht H T or L T Tabular correction Stage of tide above M L V	12 0 5 7 6 3	Feature bares Stage of tide above MLW Feature above MLW	3 6 9	46 C 168
Time H T or L T Required time Interval	12 39 10 00 2 39	Ht H T or L T Tabular correction Stage of tide above MLW	12 0 4 8 7 2	Feature bares Stage of tide above MLW Feature above MLW	4 7 11	46 C 168
Time H T or L T Required time Interval	12 39 10 15 2 24	Ht H T or L T Tabular correction Stage of tide above MLW	12 0 4 1 7 9	Feature bares Stage of tide above MLW Feature above MLW	4 8 12	46 C 168
Time H T or L T Required time Interval	06 38 09 35 2 57	Ht H T or L T Tabular correction Stage of tide above MLW	-0 2 6 0 5 8	Feature bares Stage of tide above MLW Feature above MLW	0 6 6	46 C 168
Time H T or L T Required time Interval		Ht H T or L T Tabular correction Stage of tide above MLW		Feature bares Stage of tide above MLW Feature above MLW		
Time H T or L T Required time Interval		Ht H T or L T Tabular correction Stage of tide above MLW		Feature bares Stage of tide above MLW Feature above MLW		

Computed by R. E. Murray Checked by E. P. Murray

FIGURE 5 18—Form M-2617-12 Tide Computation

The correction to height is determined from Table 3 When the nearer tide is high water, subtract the correction When the nearer tide is low water, add the correction

The height that a rock bares at a particular time is furnished by the field party This height is referred to the sounding datum by correcting the field values for the height of tide at the time of observation—adding the height of tide above the sounding datum (plus values) or subtracting the height of tide below the sounding datum (minus values)

5472 Tides and Shoreline

Inasmuch as the photographs are seldom taken exactly at mean high water or mean low water it is usually necessary to determine the stage of the tide at the time of photography, and to map the shoreline and shapes of offshore features not as they appear on the photographs but as they would appear had the photographs been taken with the tide exactly at mean high water and mean low water, or mean lower low water

Where the beaches have a gradual gradient there is a great difference between the positions of the mean high-water line and the mean low-water line, that is, the foreshore is wide Where the beaches are steep there is little displacement between the mean high-water line and the mean low-water line, that is, the foreshore is narrow or practically non-existent Often these small differences cannot be shown on the manuscripts However, these same areas are often overrun with rocks and ledges, some exposed at all stages of the tide, while others may be exposed at intermediate stages between high and low water



The heights above the water surface of rocks and ledges dangerous to surface navigation are generally furnished by the field surveys as of a certain time and date. They are also sometimes determined by stereo-photogrammetric methods without field data, that is, all rocks dangerous to surface navigation and without field inspection information that are of sufficient size (approximately 20 mm in diameter) to have their elevations determined by stereo-photogrammetric methods are examined and their elevations determined. The elevations of rocks shall be referred to the datum as required in **5424**.

Tide information makes it possible for the field inspector to make a more intelligent interpretation of the high- and low-water lines. It permits the office photogrammetrist to make comparisons among photographs taken at different known stages of tide which will result in a more intelligent interpretation of the photographs and use of field data. Thus for the positioning of an accurate mean high-water line or mean low-water line and the determination of heights of rocks with reference to a known datum, the stage of tide at the time of exposure is necessary.

### *5473 Corrections Applied to Bridge Clearances*

Field requirements are such that bridge clearances are furnished the photogrammetric office corrected to the plane of mean high water as a part of the complete tabular bridge report. The field party procedure requires that

(a) The time of day and the date at which all vertical clearances are measured will be made a part of the record. Where the measurements are over open tidal waters they will subsequently be corrected to the plane of mean high water by use of the predicted tide tables.

Vertical measurements referred to the surface are susceptible to error in applying the tidal corrections. Therefore certain precautions are necessary in choosing a time to make such measurements. When practicable to do so, the field measurements will be made at or near either high or low water. Strong prevailing winds in the general direction of the stream or channel can make predicted tides erroneous to the extent of several feet. Therefore, vertical clearance measurements will usually be avoided when these conditions occur.

(b) In certain navigable rivers the height of the water surface is influenced considerably more by the volume of water flowing out of the river than by the tides, and in some navigable rivers there are no tidal effects. In such cases vertical clearance measurements will be corrected as follows:

(1) The local District Engineer will be contacted and information will be sought as to the height of the water surface with reference to the adopted mean high water plane of reference at the particular time and date the measurement was taken. On receipt of these data the vertical clearance measurements will be corrected to refer to the mean high water datum as used on the nautical charts or as adopted by the District Engineer.

(2) Where the procedure outlined in (1) cannot be followed due to inability to obtain the necessary information the vertical clearance measurements may be corrected from local information as to the relative height of the river at the time of measurement or measurements may be made to high water marks or bridge abutments, fender pilings or other objects.

The office photogrammetrist should verify the corrections applied to vertical clearance measurements made in the field. For measurements from water level to which tide corrections are to be applied, the method using Table 3 of the Tide Tables as explained in **5471** shall be used with slight variations.

The form is completed through Stage above MLW for the time and the date the vertical bridge clearance was measured in the same manner as for rocks. If the stage of tide is above the sounding datum (MLW or MLLW), the correction is added to the field measurement of the vertical clearance, thus referring the measurement to the sounding datum. The mean range of tide is then subtracted from this value to reduce the clearance to mean high water.

If the stage of tide is below the sounding datum, the amount is added subtracted from the field measurement of the vertical clearance to refer it to the sounding datum. The mean range is then subtracted from this value to refer the measurement to mean high water.

#### 548 PREPARATION OF THE MANUSCRIPT FOR FILING

After the photogrammetric office review of the manuscript, it shall be trimmed so that its over-all dimensions do not exceed 36 by 48 inches. Generally it should be trimmed so that there is a 2- to 3-inch margin beyond the neat limits of the map. After being trimmed, the manuscript shall be edged, if possible, with Scotch tape dispensed from a *Scotch Edger*.

For ready identification of the manuscript when it is filed, the registry number shall be lettered at the lower right corner of the margin of each of the longer sides in black permanent plastic ink in approximately 30-point lettering. The number will thus appear at the lower right corner and the upper left corner when either of the longer sides of the manuscript is towards the user.

### 55 THREE-POINT SEXTANT FIXES

#### 551 GENERAL INFORMATION

Sextant fixes are used by photogrammetric field parties for the location of objects not identifiable on the aerial photographs. The stations for such sextant fixes may be objects that are exactly identified on the aerial photographs. These stations are then located by the radial plot, or stereoscopic instrument, after which the sextant fixes can be plotted.

The position data for sextant fixes will be recorded on the back of the field photograph on which the stations for the three-point fix are identified. All entries and notes will be recorded so that they can be clearly understood at any future date.

Objects identified as temporary stations for a three-point fix for the purpose of locating a rock, shoreline, etc., will be plainly marked on the field photographs and each will be assigned a capital letter in alphabetical order, the letters I and O being omitted. When the alphabet is exhausted, double letters will be used—the first series being AA, BA, CA, etc. Letters with primes, as A', B', and C', will not be used. Each map is lettered individually—that is, a new alphabetic series is started for each map.

Positions will be numbered consecutively, starting with 1, on each map. The field parties will endeavor to select stations for a fix that are within the limits of the map on which the three-point fix position falls.

Photo (topo) stations and photo-hydro stations will be used for three-point fix stations wherever it is possible. They will be recorded as they are named or numbered on the photographs.

The names of the three stations of a three-point fix will be recorded vertically. *The objects will be recorded clockwise*—that is, the left object first, the center object next, and the right object last. The angles are recorded opposite the names of the left and right stations, respectively.

Supplemental angles, or cuts observed at three-point fixes are recorded below the corresponding fixes. The names of the two objects, recorded clockwise, are entered on the same line with the cut angles, as—

1	At rock bearing 3 feet at 10 13 a m	13 June 1949	
	A -----	73°42'	
	371 -----		
	376 -----	46°33'	
	376 — B -----	67°04'	Check angle
	376 — Red Nun Buoy -----	41°17'	" "

Recorded data will never be erased—all corrections will be made by crossing out the incorrect entry and making the correct one directly above or to one side in such a way that it cannot be misinterpreted. Data rejected as erroneous will be indicated by an "R" written over the entry.

### 552 PLOTTING THREE-POINT FIX POSITIONS

Three-point fix positions are plotted graphically on the map manuscript by the use of a protractor. Three types are generally used: metal three-arm, transparent celluloid, and tracing paper protractors. These protractors are described in detail in subject 453, Special Publication No. 143, Hydrographic Manual.

Most three-point fix positions should be plotted on manuscripts with the metal three-arm protractor. The use of the celluloid protractor shall be limited to where the stations are not more than 10 inches from the positions, the sum of the two angles is not less than 60° and the smaller of the two angles is not less than 20°. The use of tracing paper protractors shall be limited to plotting positions so close to the stations that one or more of the stations is obscured by either the metal or the celluloid protractor.

The three-arm protractors made of metal or celluloid have a fixed center arm and two movable arms with which the two observed angles can be set. To plot a three-point fix, the left movable arm is turned away from the fixed arm by the approximate amount of the left angle, the arm is clamped in place and the precise setting made with the tangent screw and vernier. The same procedure is followed for setting the right angle. After the angles have been set, the instrument should be held by the metal circle and the fixed arm, and centered at the estimated position of the fix. With fingers of one hand used as a guide to keep the fixed arm bisecting the center station, the protractor is moved toward or away from the stations until each arm bisects its respective station. During this operation speed may be gained by keeping the side arms at approximately equal distances from the respective stations. A prick mark or pencil mark is then made at the center of the protractor, the position thus marked representing the location of the observer at the time the angles were taken.

In using a metal protractor it will occasionally be found that one or more of the plotted control stations is obscured by the metal circle. To overcome this difficulty, the celluloid protractor may be used. Where a station is so close to the center of either of these protractors that it is obscured, a tracing paper protractor should be used.

To lay off an angle on the tracing paper protractor, the value of the angle is marked on the graduated circle and a fine straight line is drawn from the marked center through this point. The left angle is marked to the left of the zero on the scale and the right angle to the right. The fix is then plotted in the manner described above.

To plot an angle from a known position, the metal protractor is centered accurately over the position by means of the transparent centerpiece, the fixed arm is rotated until it passes through the plotted position of the initial object, and the right or left movable arm is set at the desired angle. The cuts may then be drawn along the fiducial edge of the arm with a chisel-edged pencil. Before each cut is drawn, the position of the protractor

should be checked to see that it is properly centered over the known position and that the fixed arm passes through the initial point

In plotting accuracy should be the objective. Speed will be gained with experience.

Temporary stations identified and located by radial plot for plotting sextant fixes and the positions of sextant fixes which are not permanent shall be symbolized by circles 2.5 mm in diameter in red ink on the back of the manuscript. The letter of a temporary station or the number of the plotted position shall be indicated adjacent to the circle. These may be removed from the manuscript after the review in the Washington Office.

## 56 SCALING POSITIONS

The geographic positions—that is, the latitude and longitude—are required for many points located photogrammetrically or by planetable. For convenience the latitude and longitude are given in degrees and minutes with the seconds of arc in meters. The accuracy of the positions of photo (topo) points and topographic points does not warrant the scaling of the positions of these points to tenths of meters. Therefore, the seconds in meters (*dms* and *dps*) shall be scaled and corrected for any distortion of the manuscript to the nearest meter and shall be checked with the same accuracy.

### 561 SCALES

The seconds in meters may be scaled or checked with a beam compass and metal meter scale (see 141), the Lockerbie Diagonal Scale, the Sylar-Lockerbie Scale, or a triangular centimeter scale if the scale (or a section thereof) is subdivided to 0.5 mm.

The Lockerbie Scale may be used in the following manner for scaling the *dms* and *dps* of points. The zero of the scale (the small space between the two lines at the base) can be placed over the given point and any vertical line of the scale placed in coincidence with the nearest meridian line. Without further adjustment, the seconds in meters between the point and a parallel of latitude are indicated at the place where the parallel intersects one of the diagonal lines of the scale. The same process is followed to scale the longitude except the vertical line is placed in coincidence with the nearest parallel. The seconds in meters between the point and a meridian are indicated at the place where the meridian intersects one of the diagonal lines of the scale.

The Sylar-Lockerbie Scale consists of four Lockerbie scales printed in a single diagram on the underside of a thin sheet of transparent vinylite. The center point of the scale is placed directly over the point to be scaled. The vertical line of the scale nearest a meridian is oriented parallel to that meridian. The four quantities in meters, namely forward latitude, back latitude, forward longitude, and back longitude, can all be measured at the one setting. This scale is obtainable on request from the Washington Office in two scale ratios—1:10,000 and 1:20,000. (See fig. 5-19.)

A centimeter scale with 0.5 mm subdivisions is useful for scaling the positions of stations on manuscripts at scales of 1:10,000 and 1:20,000. On these manuscripts the seconds in meters may be read directly. To do so, the centimeter scale must be held parallel with the nearest meridian for scaling latitudes and parallel with a parallel of latitude for scaling longitude, except when the manuscript is of a scale slightly smaller than 1:10,000 or 1:20,000. In the latter case, the scale is placed at a slight angle to the projection lines so that it bisects the point, the zero of the scale coincides with one meridian or parallel and the exact reading on the scale corresponding to one subdivision of the projection (at the latitude of the station) coincides with the opposite meridian or parallel.

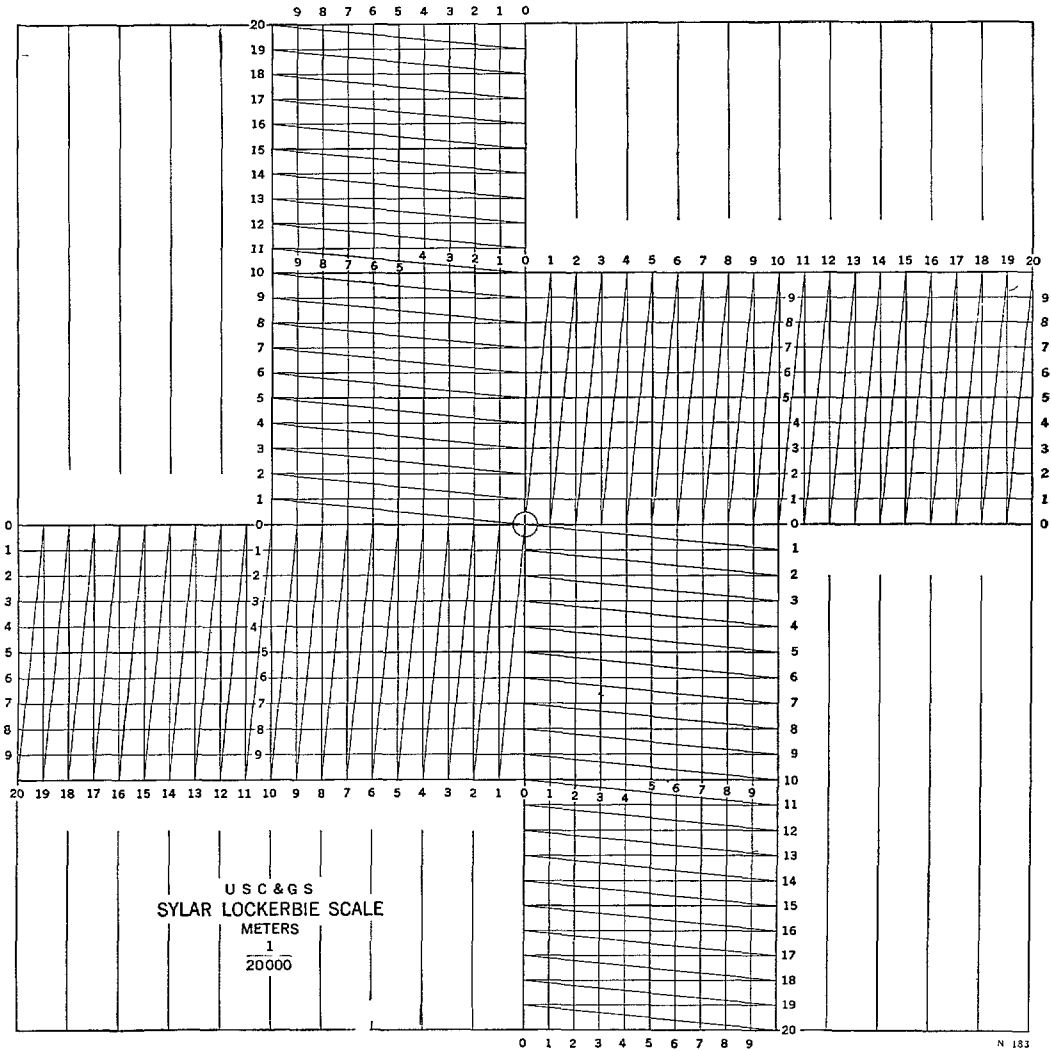

FIGURE 5 19—The Sylar Lockerbie Scale

The value of the seconds in meters of latitude or longitude of the point can then be read directly from the scale. This method compensates for the scale error of the projection and the values need not be corrected as discussed in 562

### 562 CORRECTION FOR SCALE ERROR OF THE PROJECTION

Map manuscript projections often are not exactly at even scales, such as 1 10,000 or 1 20,000. Consequently, the *dms* or *dps* scaled by the methods discussed in 561 must often be corrected for the scale difference of the manuscript projection. In scaling positions, the manuscript projection should always be checked for scale by comparing scaled distances between projection lines with the corresponding values given in Special Publication No 5, Polyconic Projection Tables

To correct distances scaled from manuscripts that are distorted or constructed at a scale slightly larger or smaller than standard scales, the following relation should be used

$$\frac{\text{Tabular value} - \text{Scaled value}}{\text{Scaled value}} = \pm \text{Correction factor}$$

Each scaled distance should be multiplied by this factor and the amount added to or subtracted from the scaled value to obtain the true value

To plot a station on a distorted manuscript or one constructed at a scale slightly larger or smaller than standard scales the following relation should be used

$$\frac{\text{Tabular value} - \text{Scaled value}}{\text{Tabular value}} = \pm \text{Distortion factor}$$

Each true value that is to be plotted on the manuscript should be multiplied by this factor and the amount added to or subtracted from the true value

### 57 DISCREPANCY OVERLAY

A discrepancy overlay is a transparent sheet, superposed upon a manuscript, on which are noted any discrepancies and inadequacies found during the process of compilation. It shall be prepared concurrently with the delineation of the manuscript.

The overlay is used to call attention to inadequacies in field surveys, and to discrepancies in photographic interpretation, in field identification, and between the field surveys and office compilation. The use of an overlay saves writing long descriptive notes. Inadequacies are noted on the overlay adjacent to the map features concerned and this provides a ready reference for field verification, field identification, or additional surveys.

A note in the office is for consultation only. It is not to be used for field work.

#### 571 PREPARATION OF THE DISCREPANCY OVERLAY

Discrepancy overlays shall be made on clear acetate sheeting. Because of the differences in the coefficients of expansion and contraction between the various plastic sheetings, intersecting ticks of the parallels and the meridians shall be shown at the corner intersections and at those intersections nearest the middle of each side of the manuscript. Full projection lines shall not be drawn on overlays.

Discrepancy overlays shall be made for all topographic and planimetric manuscripts, they shall not be made for shoreline manuscripts unless specified by project instructions.

All notes shall be made in black permanent plastic ink. These notes may be printed or written—but they must be opaque, neat, and legible. Every effort should be made to avoid unnecessary work on the overlays as they are for temporary use only. The main requirements are completeness, legibility, and opaqueness for reproduction.

All discrepancies, regardless of types, for each manuscript shall be shown on the same overlay. Examples of such discrepancies are the inability to interpret photographic detail involving physical and cultural features—drainage, relief, etc.—, discrepancies of field surveys including field inspection of control and of culture, misspelled or misapplied geographic names, discrepancies in boundaries, and inadequacies of field surveys or of office compilation—which are to be investigated and corrected during the field edit.

Discrepancy overlays are not to be construed as sheets of criticism compiled in photogrammetric offices. They are a graphic means of calling attention to all the inadequacies of the manuscript that cannot be satisfactorily compiled or corrected in the photogrammetric offices without additional help from the field. Overlays are prepared for the sole purpose of producing maps that are complete and accurate and that meet all the required Federal standards, Coast and Geodetic Survey standards, and any special or project instructions.

## 572 DISCREPANCIES ON SHORELINE MANUSCRIPTS

Discrepancy overlays shall be made for shoreline surveys only where the project instructions specify that the surveys will be field-edited. For all other shoreline surveys important discrepancies that should be cleared up by surveys at some future indefinite time shall be reported in the Descriptive Report completely and unambiguously.

### 58 PHOTOGRAMMETRIC OFFICE REVIEW OF THE MAP MANUSCRIPT AND ITS ASSOCIATED DATA

Each manuscript, with its discrepancy overlay, compilation report, and associated records, shall be reviewed in the photogrammetric office where it was compiled before being forwarded to the Washington Office. The review shall be made by a member of the review section or by a photogrammetrist assigned to do it. Similarly, each manuscript compiled in the Washington Office shall be reviewed in the section in which it was compiled before being submitted for final review and publication.

The photogrammetric office review shall be made in accordance with the detailed instructions contained in this manual, and the record of the review shall be recorded on Form T-2 (see 5811). The completed form shall be inserted in the Descriptive Report immediately after the compilation report.

The reviewer shall ensure that the manuscript, the report, and the records are complete and accurate and in accordance with the instructions and requirements prescribed in this manual so far as this is practicable with the data available. He shall have the use of any plotting sheets, computations, notes, sketches, etc., made by the photogrammetrist during the delineation of the manuscript.

Omissions and inaccuracies found during the photogrammetric office review of the manuscript and its associated data shall be noted. The correction of these omissions and inaccuracies shall be made by the photogrammetrist who delineated the manuscript so far as this is possible from the available data. These additions and corrections shall then be verified by the reviewer.

It is emphasized that the photogrammetric office review does not decrease the responsibility of the supervisor of the compilation section (whether the compilation is by graphic or stereoscopic instruments) from detailed supervision of all work in progress in his section. It shall be his responsibility to turn out adequate map manuscripts which require few, if any, corrections after the photogrammetric office review. The supervisor of the graphic compilation section shall endeavor to maintain daily contact with work in progress, particularly when it is being done by a less experienced photogrammetrist, and shall see that employees are instructed regarding errors found during review so that mistakes are not repeated.

In general, the photogrammetric office review of items indicated on Form T-2 will be final and will not be repeated in the Washington Office. The Washington Office review ordinarily will be limited to a general examination of the manuscript and the accompanying data with reference to over-all conformity with standards and policies, and to the preparation of the manuscript for smooth drafting.

### 581 REVIEW OF THE MAP MANUSCRIPT

During the review of a manuscript the reviewer will, no doubt, have to make many notations. It is recommended that a review overlay on tracing paper be used for the indication of all errors and omissions. The use of such an overlay by the reviewer eliminates the necessity of marking the manuscript. The more a manuscript is cleaned, the more likely it is

that the lines on it will not be sufficiently opaque for good reproduction. This is the first item of review—that the reviewer makes certain that everything inked on the manuscript is opaque and will reproduce satisfactorily. He must not mar the manuscript or in any way adversely affect the opaqueness of the delineated lines, letters, and figures. Furthermore, when an overlay is used the corrections can be checked or crossed out on the tracing as they are completed by the photogrammetrist. With such a record, the reviewer can ascertain that each item has been satisfactorily corrected. If the notes are made directly on the manuscript and they are deleted after being corrected, the reviewer has no ready means of checking each item that has been corrected.

### 5811 Instructions for Photogrammetric Office Review

These instructions specify what shall constitute the photogrammetric office review. The items of these review instructions are numbered with reference to the numbers shown on Form T-2, Photogrammetric Office Review.

Form T 2

#### PHOTOGRAMMETRIC OFFICE REVIEW

T

1 Projection and grids \_\_\_\_\_ 2 Title \_\_\_\_\_ 3 Manuscript number \_\_\_\_\_ 4 Manuscript size \_\_\_\_\_

##### CONTROL STATIONS

5 Horizontal control stations of third order or higher accuracy \_\_\_\_\_ 6 Recoverable horizontal stations of less than third order accuracy (topographic stations) \_\_\_\_\_ 7 Photo hydro stations \_\_\_\_\_ 8 Bench marks \_\_\_\_\_ 9 Plotting of sextant fixes \_\_\_\_\_ 10 Photogrammetric plot report \_\_\_\_\_ 11 Detail points \_\_\_\_\_

##### ALONGSHORE AREAS

(Nautical Chart Data)

12 Shoreline \_\_\_\_\_ 13 Low water line \_\_\_\_\_ 14 Rocks shoals etc \_\_\_\_\_ 15 Bridges \_\_\_\_\_ 16 Aids to navigation \_\_\_\_\_ 17 Landmark \_\_\_\_\_ 18 Other alongshore physical features \_\_\_\_\_ 19 Other alongshore cultural features \_\_\_\_\_

##### PHYSICAL FEATURES

20 Water features \_\_\_\_\_ 21 Natural ground cover \_\_\_\_\_ 22 Planetable contours \_\_\_\_\_ 23 Stereoscopic instrument contours \_\_\_\_\_ 24 Contours in general \_\_\_\_\_ 25 Spot elevations \_\_\_\_\_ 26 Other physical features \_\_\_\_\_

##### CULTURAL FEATURES

27 Roads \_\_\_\_\_ 28 Buildings \_\_\_\_\_ 29 Railroads \_\_\_\_\_ 30 Other cultural features \_\_\_\_\_

##### BOUNDARIES

31 Boundary lines \_\_\_\_\_ 32 Public land lines \_\_\_\_\_

##### MISCELLANEOUS

33 Geographic names \_\_\_\_\_ 34 Junctions \_\_\_\_\_ 35 Legibility of the manuscript \_\_\_\_\_ 36 Discrepancy overlay \_\_\_\_\_ 37 Descriptive Report \_\_\_\_\_ 38 Field inspection photographs \_\_\_\_\_ 39 Forms \_\_\_\_\_ 40 \_\_\_\_\_

R I

S p r v R w s t n U t

41 Remarks (see attached sheet)

##### FIELD COMPLETION ADDITIONS AND CORRECTIONS TO THE MANUSCRIPT

42 Additions and corrections furnished by the field completion survey have been applied to the manuscript. The manuscript is now complete except as noted under item 43.

C m p l

S p r v

43 Remarks



Form T-2, Photogrammetric Office Review, is purposely concise and is essentially a listing of the items to be covered in the photogrammetric office review with space for initialing by the reviewer to show his responsibility for each item which he completes. Inapplicable items or parts of items that are inapplicable shall be crossed out.

The instructions consist mainly of questions which the reviewer must answer to his own satisfaction before he accepts the responsibility for the completeness of the item listed on the form. The following paragraphs are numbered to conform to the numbers on Form T-2 and indicate the various items to be considered by the reviewer, the references are to the instructions contained in this manual.

1 *Projection and grids* Does the data record show responsibility for drawing and checking the projection and grids shown on the manuscript (fig 72)? Does the data record give the position of the datum station and name the State grids and their zones that are shown on the manuscript (fig 72)? Have the grid ticks and intersections been inked accurately in accordance with instructions (4136 and fig 44)? Are the projection and grid numbers correctly inked on the manuscript (4136 and fig 44)?

2 *Title* Has the map title been lettered in accordance with the instructions regarding the style of lettering and content and without superfluous information (fig 546)?

3 *Manuscript numbers* Have the manuscript numbers been lettered in such a way that they appear at the lower right corner when one is facing either of the longer edges of the sheet?

4 *Manuscript size* Are the neat limits of the manuscript in accordance with the project layout? Has the manuscript been trimmed to a maximum size of 36 by 48 inches or according to 548?

### Control Stations

5 *Horizontal control stations of third-order or higher accuracy* Does Form T-1, Data Record, show the responsibility for plotting and checking the positions of horizontal control stations (fig 72)? Have all stations existing at the time of the field survey as evident from recovery notes been shown, or have those shown in congested areas been selected in accordance with the instructions (5461)? Are the names and dates of establishment of horizontal control stations (not the recovery dates) correctly shown as listed in the published geographic positions (5461)? Is Form M-2388-12, Control Station Data (fig 45), complete checked and attached to the Descriptive Report? Where a horizontal control station is a prominent object, is the descriptive name shown on the manuscript in accordance with instructions (5461)? Where a station is an aid to navigation, is the name of the aid shown as listed in the Light List (5461)? Have Form 525 descriptions been submitted for all stations established by this survey (see Table 71)?

6 *Recoverable horizontal stations of less than third-order accuracy (topographic stations)* Have all recoverable topographic stations within the area of the manuscript been shown (4611 and 5463)? Where these stations have been plotted from computed positions or transferred from another survey sheet, has the plotting or transfer been checked? Are the fourth-order stations used for control of the radial plot or stereoscope instrument bridging listed on Form M-2388-12, and has the listing been checked (only those fourth-order stations used to control the plot or bridging shall be listed on Form M-2388-12)? Have the photo (topo) stations shown on this manuscript been accurately located as evident from accurate field identification accurate identification on the office photographs and the care with which the radial plot was done (4611 and 5463)? Are the names and years of establishment (not recovery dates) shown in accordance with instructions (5462 and 5463)? Are azimuth marks located as photo (topo) stations symbolized correctly (5463C)? Where a topographic or photo (topo) station is a prominent object, is the descriptive name shown in accordance with instructions (4611B, 5462 and 5463)? Where a station is an aid to navigation is the name of the aid shown exactly as in the Light List (4611A and 5463A)? Where stations of fourth-order accuracy have been located by triangulation methods, are the lists of directions included in the field inspection report (see 724)? Have Form 524 descriptions been prepared for all permanent fourth-order stations located by this survey (see 5462)? Have the geographic positions listed on those descriptions been checked?

7 *Photo-hydro stations (4612 and 5464)* Have the photo-hydro stations shown on the manuscript been accurately located as evident from the identification on the field photographs the identification on the office photographs and the care with which the map has been compiled? Are these stations numbered on the manuscript in accordance with the numbers shown on the field photographs? Are the descrip-

tions listed in the Descriptive Report numbered in accordance with the numbers shown on the field photographs, and are these descriptions correct in accordance with the field notes?

8 *Bench marks (5466)* Have all existing permanent bench marks as evident from the field recovery been shown in accordance with the instructions? Has each bench mark been correctly symbolized and designated as to type (fig 542)? Is each bench mark numbered according to the published list, or as listed on Form 638 or Form 685? (Dates of establishment of bench marks are not to be shown) Is the elevation of each bench mark shown to the nearest foot? Have the elevations of bench marks lettered on the manuscript been checked against the published or the field records? Is the responsibility for this checking indicated on the Data Record?

9 *Sextant fixes (55)* Have sextant fixes taken by the field party for location of map details been plotted? Are they correctly symbolized? Were the fixes adequate for accurate location of the points as evident from the records and from discussion with the photogrammetrist? Have these fixes been correctly plotted as evident from a discussion with the photogrammetrist, and possibly by replottting some of them—that is, by spot checking? Are the sextant fixes recorded on the backs of the field photographs? If not, does the field inspection report or the compilation report state where they are recorded?

10 *Photogrammetric plot report (725)* Has a report been made on the radial plot or the stereoscopic instrument bridging for this map? Is a reference to this report contained in the compilation report?

11 *Detail points (462)* If the map was compiled by graphic methods, were the detail points adequately placed with reference to the terrain features, in sufficient number, and accurately located?

### Alongshore Areas (Nautical Chart Data)

12 *Shoreline (5421)* Was field inspection adequate for interpretation of the shoreline? Was the office interpretation of shoreline from the field inspection photographs and stereoscopic study adequate? Has the shoreline been accurately delineated in sufficient detail? Was the tide computed and checked for the time and date of the photographs (547)? Has the date of location of the shoreline (mean high-water line) been entered in Form M-2618-12(4), Data Record, with an adequate segregation of sections of shoreline located at dates different from that for the rest of the area covered by the manuscript?

13 *Low-water line (5422 and fig 522)* Has the low-water line been shown where it has been interpreted by field inspection? Has the low-water line been shown where the photographs were taken at or near the time of low water? Was the tide computed and checked for the time and date of the photographs used for this delineation (547)?

14 *Rocks (5424) shoals (5423E), etc* Was field inspection adequate for interpretation of such offshore features as could be economically mapped? Have the rocks shoals, etc, been adequately interpreted and adequately located in the office? Are they symbolized correctly? Have the elevations of rocks been computed correctly from the field data? Are the elevations of rocks shown in accordance with instructions? Are the notes relative to offshore and alongshore features clear and concise? Has the excessive use of leaders and arrows been avoided, but where they have been used are they drawn so as not to obliterate or confuse the shoreline and alongshore details? Does the Descriptive Report contain a chart diagram showing the features between the high water and low water plines that have been left to be located by the hydrographic party? Has a separate copy of this diagram been included with the notes for the hydrographer?

15 *Bridges (5425B, 5425L, and 5443A)* Were the vertical clearances of bridges and cables corrected to the plane of reference by the field party? Are the bridge clearances shown correctly in accordance with field data? Are the types of bridges shown correctly? Does the Descriptive Report contain copies of any letters by the field parties concerning differences in clearance between the field measurements and clearances published by the Corps of Engineers?

16 *Aids to navigation (5461, 5462, and 5463A)* Have these been accurately located, listed on Form 567, and the listed geographic positions checked? Does the chart diagram mentioned under item 14 also show aids within the limits of this map that were not located?

17 *Landmarks (5461, 5462, and 5463B)* Have the landmarks selected by the field party been accurately located, listed on Form 567, and the listed geographic positions checked? Have the landmarks to be deleted been listed on a separate Form 567 in accordance with instructions?

18 *Other alongshore physical features (5423 and figs 522, 523, and 536)* Have areas of marsh, swamp, mangrove tidal drainage, etc, been delineated as required? Have bluffs, cliffs etc been shown? Are those that are landmarks adequately portrayed? Has the character of the foreshore been correctly symbolized or identified by legend?

19 *Other alongshore cultural features (5425)* Has the field inspection of alongshore cultural features been utilized? Are there alongshore cultural features whose office interpretation is questionable? Have they been shown in accordance with instructions (fig 528)?

### Physical Features

20 *Water features (5431)* Has all drainage discernible on the photographs and that identified by field inspection been shown? Are lakes and ponds correctly shown? Have the limits of swamp, marsh, and mangrove been delineated? Have the limits of other water features been delineated?

21 *Natural ground cover (5433D)* Was the field inspection of woodland areas adequate? Was the office interpretation of these areas from the field inspection notes adequate? Have they been correctly symbolized and classified? Have deficiencies been noted on the discrepancy overlay for completion during field edit? Are sand dunes correctly delineated (5432Dh)?

22 *Planetable contours (5432)* Have planetable contours on photographs been examined under the stereoscope as a check on the adequacy of the planetable sketching? Have minor deficiencies in expression, as stream crossings and shapes of ravines, ridges, and shoulders been corrected? Have the planetable contours been correctly delineated on the manuscript with an adequate number of detail points and proper consideration for abrupt changes in elevations and for the correction of relief displacement on the photograph? Have major deficiencies in expression been noted on the discrepancy overlay for field completion?

23 *Stereoscopic instrument contours (5432D)* Have multiplex contours been verified as to shape and for minor omissions of detail by a separate stereoscopic examination of prints of the aerial photographs? Have deficiencies in the contouring been noted on the discrepancy overlay for field completion? These deficiencies will include inadequately controlled areas, areas where the photographs were not clear, and areas where for any reason the operator is uncertain of the contour accuracy.

24 *Contours in general (5432 and figs 538 and 539)* Have the contours been delineated in accordance with the instructions as to weights of lines, contour elevations, etc? Are the contour elevations correct? Do the contours in all cases agree with the spot elevations and the bench mark elevations? Is the symbolization in accordance with instructions for ditches and levees?

25 *Spot elevations (5432E)* Have spot elevations been selected and placed in accordance with instructions? Are the spot elevations correctly symbolized and designated as to type? Have the elevations been checked against the field records and has the responsibility for this checking been shown on Form T-1, Data Record?

26 *Other physical features (543 through 5433)* Are other physical features important to the map adequately portrayed or noted?

### Cultural Features

27 *Roads (5441)* Have roads been properly symbolized and classified in accordance with field data and have they been accurately located? Have deficiencies been noted on the discrepancy overlay for completion? Are the road objectives complete and have they been lettered in accordance with instructions?

28 *Buildings (5446)* Was the field inspection adequate? Have the buildings been accurately located, correctly symbolized, and correctly classified in accordance with field data? Have known deficiencies been indicated on the discrepancy overlay for field completion? Have the functional and proper names of buildings been shown correctly in accordance with the field records and with instructions (5416)?

29 *Railroads (5442)* Have railroads been accurately located and correctly symbolized in accordance with field data?

30 *Other cultural features (5444 and 5445)* Have cross-country transmission lines, telephone lines, telegraph lines, etc., been delineated?

### Boundaries

31 *Boundary lines (545, 5451 and 5452)* Have boundary monuments identified by the field survey been accurately located and correctly symbolized? Have the boundary lines been compiled in accordance with the field reports and legal descriptions and in accordance with instructions? Have deficiencies been noted on the discrepancy overlay for field completion? Have unreliable boundary lines been so designated on the manuscript and noted on the discrepancy overlay?

32 *Public land lines (545 and 5453)* Have the original or accepted corners identified by the field party been accurately located and correctly symbolized (fig 544)? Have the land lines been developed and compiled in accordance with the field data and the public land survey plats? Have they been classi-

fied as "Reliable" or "Unreliable"? Have deficiencies been noted on the discrepancy overlay for field completion?

### Miscellaneous

33 *Geographic names (5415)* Have all geographic names on the standard geographic names sheet been transferred to the manuscript, correctly spelled and placed in accordance with the standard? Is the size of the lettering in accordance with instructions? Has the required alphabetical list of geographic names been prepared?

34 *Junctions (463 and 5414)* Have junctions been made with maps already completed in accordance with instructions? Have junction details been transferred from this manuscript to adjoining uncompleted manuscripts?

35 *Legibility of the manuscript (5 and 51)* If the manuscript is a planimetric or topographic map, is the compilation-drafting of the entire manuscript sufficiently legible so that a photographic print will be adequate for use during field edit? If it is a shoreline manuscript, is the smooth compilation-drafting adequate for reproduction without redrafting? Are the symbols, abbreviations, and lettering in accordance with the requirements of this manual?

36 *Discrepancy overlay (57 and 571)* Is the discrepancy overlay now complete and are the notes concise and at the same time specific so that those making the field edit will understand them?

37 *Descriptive Report* Is the Descriptive Report complete and adequate (72)? Is Form T 1, Data Record, complete (723)? Have references been made in the field report and compilation report to all special reports not bound with the Descriptive Report such as geographic names report, radial plot report, report on boundaries, and report on public land lines (see 72)? Has the manuscript been compared with the latest issues of the largest scale nautical chart or charts of the area, as a check against the completeness of the manuscript as to shoreline and alongshore details? In the case of shoreline surveys not to be field-edited, have the deficiencies been specifically listed in the compilation report? Have important new details shown on this manuscript, such as large piers, been specifically listed in the compilation report for immediate application to the charts? Is the Descriptive Report concise and specific and have repetitious and useless statements been avoided in accordance with the instructions for Descriptive Reports?

38 *Field inspection photographs* Have the field inspection photographs been utilized to their fullest extent? Are all the field inspection photographs needed for the field edit of the map ready for transmittal to the Washington Office with the manuscript?

39 *Forms* Are the following forms complete and ready for transmittal with the manuscript

1 Form 567

2 Form 524

3 Form M-2226-12, Station Identification Card

40 *Signatures* The reviewer shall initial all completed items on Form T-2. He shall cross out inapplicable items. The form shall then be signed by the reviewer and his supervisor.

41 *Remarks* A separate sheet of paper shall be used by the reviewer for any remarks pertinent to the review that cannot be fully covered on Form T-2. He shall sign this sheet and attach it to Form T-2. In the case of most manuscripts the reviewer will encounter items which are not complete because of inadequacies in the field data or for other reasons, and which cannot be taken care of in the photogrammetric office. These shall be specifically mentioned in the remarks. The remarks made by the reviewer shall be concise and specific, but shall furnish information derived from the photogrammetric office review that is vital to the field edit or the Washington Office review and that cannot be adequately noted on the discrepancy overlay. The remarks by the photogrammetric office reviewer shall not include a repetition of information included in the Descriptive Report or on the discrepancy overlay. If not needed, the remarks may be omitted entirely. *Remarks applicable to the content of any instruction item number shall be referenced to that item.*

42 This item as stated on Form T-2 is self-explanatory. After the correction and additions from field edit have been applied, the employee responsible for making the corrections and additions shall sign the form. The supervisor shall also sign the form after such inspection and verification of the work as he considers necessary.

43 *Additional remarks* If after applying all field-edit data any item is known to be deficient, that fact shall be specifically mentioned under Remarks item 43 on Form T-2.

### 582 REVIEW OF THE DISCREPANCY OVERLAY

Any questionable items and discrepancies found during the delineation of the map manuscript that cannot be satisfactorily adjusted during the photogrammetric review are

retained on the discrepancy overlay for final decision by the field-edit party. Any such items and discrepancies found during the review shall also be noted on the overlay.

The reviewer shall check the overlay as he reviews the manuscript to make certain that all necessary items are on the overlay and are presented clearly, explicitly, and in sufficient detail to be readily understood. He shall ascertain that no insignificant or inconsequential items are noted, as each item on the discrepancy overlay will, in all probability, require additional field work.

The reviewer shall ensure that the register marks on the overlay are correct and are sufficient for the proper orientation and positioning of the overlay on the manuscript.

### 583 REVIEW OF THE REPORTS AND RECORDS

As the photogrammetric office review progresses, each statement in the compilation report shall be considered and each paragraph shall be marked with a check when it is accepted as being correct and complete. The Data Record and Statistics of the Descriptive Report (see 72) shall also be reviewed to ensure correctness and completeness.

Where additional information or photographic interpretation has altered positive statements in the compilation report, the reviewer shall inform the photogrammetrist who delineated the manuscript and wrote the report of the irreconcilability of the manuscript and the report. The corrections to the report may be made jointly by the reviewer and the photogrammetrist to the satisfaction of both.

The reviewer shall make certain that all applicable items are included in the report and that the field report has been considered during the delineation of the manuscript and the completion of the accompanying reports and records.

He shall check the geographic names list (see 7261) against both the manuscript and the final name standard to ensure correct spelling of all names.

A check shall be made of Notes to Hydrographic Parties to ensure that only necessary, not obvious or repetitious, information is included.

The reviewer shall be sure that the scaling of landmarks, aids to navigation, and photo stations, has been checked. (This checking should be done by competent personnel of the compilation section.) He shall check their names as shown on the map manuscript against the completed Forms 524 and 567.

The reviewer shall also check the station numbers, the photograph numbers, and the descriptions of the photo-hydro stations as listed in the report against the field description and the manuscript number of each of these stations.

### 59 MAP MANUSCRIPT COMPLETION

Map manuscripts prepared from aerial photographs that have not been field inspected prior to compilation are of necessity incomplete because pertinent details are obscured by foliage, clouds, or shadows and because some map features cannot be obtained solely from the photographs. Such manuscripts may also be erroneous because of misinterpretation or misidentification of photographic detail. This last is especially applicable to the shoreline and alongshore features so important to the Coast and Geodetic Survey. Therefore it is a requirement of this Bureau, unless otherwise stated in the project instructions, that field inspection precede map manuscript compilation in order to eliminate as far as possible these inadequacies and errors from compilation. The field inspection of the photographs prior to compilation, however, does not preclude the need for field-edit surveys which comprise a final field check of the manuscript, completion and correction

of details, and horizontal and vertical accuracy tests. Field-edit surveys are made after delineation for each planimetric and topographic map and for shoreline surveys upon special instructions.

### 591 THE PROCEDURES OF MAP MANUSCRIPT COMPLETION

When completed in the photogrammetric office, the manuscript, the field inspection photographs, the discrepancy overlay, any maps or plats of the map area that have been used during the compilation, and the Descriptive Report are forwarded to the Washington Office. A preliminary examination of the manuscript is then made by an experienced member of the review section in order to call to the attention of the field-edit party any errors, discrepancies, or omissions in addition to those that have been noted by the photogrammetrist.

Upon completion of this examination photographic prints of the manuscript are made and forwarded to the field-edit party. All discrepancy notes are summarized by the reviewer on one of these prints. A copy of the Descriptive Report, all the field inspection photographs, and other pertinent records of the photogrammetric field surveys made prior to the compilation are also forwarded to the field-edit party.

One or two prints of each map manuscript—depending on the congestion of the topography—are furnished on double weight semi-matte or smooth surface paper. Planetable surveys for the purpose of investigating and checking the map, for effecting junctions with adjoining maps, for completing omitted planimetry or contours, and for vertical accuracy testing are executed on such a print. Metal-mounted planetable sheets are furnished where planetable triangulation or extensive traverses are required during field edit. All final field-edit notes, corrections, additions, and deletions are inked on one of these prints.

The field-edit report prepared for each map that is field-edited becomes a part of the Descriptive Report. This report contains statements as to the general accuracy and completeness of the map and its data as based on the field edit.

The field-edit data, all field photographs, maps, etc., pertaining to the map, and the Descriptive Report are returned directly to the photogrammetric office where the manuscript was originally compiled, except that horizontal and vertical accuracy tests are forwarded through the Washington Office for examination. In some cases project or special instructions state that *all* data are to be forwarded through the Washington Office. This is done occasionally so that the Washington Office may evaluate the adequacy of the original compilation or of the field-edit survey.

#### 5911 *Field Edit*

Field edit includes all phases of field work done on a map after compilation in order to ensure the completeness, adequacy, and accuracy of the map. It may be considered in three phases:

(1) *Field edit of the planimetry*, or the comparison of the natural and cultural features as delineated on the map manuscript with the corresponding ground detail.

During this phase of the work, deletions, additions, and corrections are made to the map manuscript by visual comparison or by actual survey methods as the circumstances require.

(2) *Field edit of the contours*. The representation of the relief by contours is compared with the actual ground detail, particularly with respect to topographic expression, and any

necessary corrections made, either by visual comparison or by actual survey methods. Some areas that cannot be contoured adequately by stereoscopic instrument may occasionally be left to be contoured during field edit.

(3) *Accuracy tests* Certain map manuscripts on each project, but not necessarily every one, are tested for vertical and horizontal accuracy. The project instructions, or special instructions at the time of field edit, will specify which maps are to be tested for accuracy.

The field-edit parties receive the field inspection photographs, the field inspection reports, the radial-plot report, and the compilation report. Any inadequacies of the field inspection are discussed in these reports. From this combined information the field-edit party is fully informed of all work done during the field inspection. Thus while it is the responsibility of the field-edit party to edit the entire manuscript, it is not necessary to repeat or check all the work of the field-inspection party. The original field inspection of the shoreline and offshore details is generally detailed and complete, therefore, the shoreline is not re-examined in its entirety during field edit but is spot checked for accuracy of interpretation and, of course, any investigation called for on the discrepancy overlay is made.

#### 5912 *Map Manuscript Correction*

The field-edit corrections will ordinarily be applied to the map manuscript in the photogrammetric office in which the manuscript was compiled and, if practicable, shall be applied by the photogrammetrist who delineated the manuscript. The manuscript shall be corrected to agree with the field-edit sheet or sheets and with the notes and instructions on these sheets or in the field-edit report.

The field editor is responsible for the final adequacy, completeness, and accuracy of each map, therefore the field-edit sheet and field-edit report shall be accepted as the final authority for correction and changes to the manuscript.

Generally the corrections will be traced or transferred directly from the field-edit sheet to the map manuscript. It is permissible, however, for the field editor to refer areas to be delineated to specified photographs on which the required detail is clearly identifiable. Areas that are to be so delineated are outlined on the field-edit sheet and are thoroughly field inspected, with detail emphasized where necessary, on the photographs. The photogrammetrist must be sure to use more than a sufficient number of control points in transferring these data. The transfer of detail of small extent may be controlled by accepted accurate detail on the map.

#### 5913 *Correction of the Descriptive Report and Accompanying Data*

Any amendments to the compilation report as a result of the field-edit corrections to the map manuscript shall be added in accordance with the instructions in chapter 7.

All accompanying records shall be corrected in accordance with the field-edit survey (see chapter 7).

#### 5914 *Verification of Field-Edit Corrections*

All corrections, additions, and deletions authorized by the field-edit party shall be verified in the photogrammetric office.

If possible, the photogrammetrist who originally reviewed the map manuscript should review the field-edit corrections.

The review in the photogrammetric office shall include the verification of the required addenda to the Descriptive Report and to the records associated with the manuscript.

# SYMBOLS AND ABBREVIATIONS







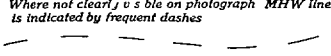
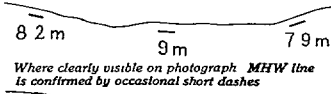
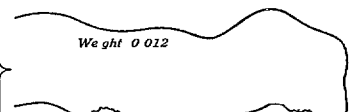
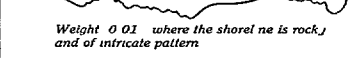
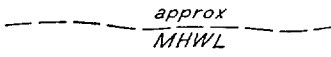
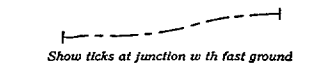

## FOR

### PHOTOGRAPHS AND MAP MANUSCRIPTS

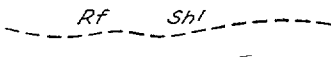
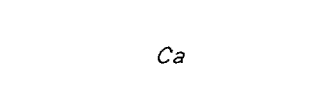
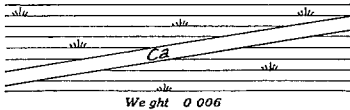
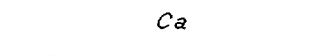
#### GENERAL REMARKS

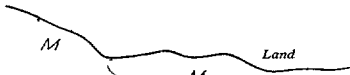
- (1) Deletions are indicated on field photographs and completion survey manuscripts by x's in green ink
- (2) The minimum space of 0.3 mm between lines and between symbols shall always be adhered to
- (3) Periods are not to be used after abbreviations in water areas on map manuscripts nor are i's and j's to be dotted in the legends notes etc *Compass - Periods are omitted after abbreviations on map manuscripts - page 236*
- (4) The details delineated along the neat limits of a manuscript for the perfecting of the junctions shall not be removed until after the completion of the photogrammetric office review
- (5) Station names numbers and dates temporarily noted on the back of a manuscript shall not be removed until after the completion of the photogrammetric office review
- (6) The front and the back of a manuscript shall not be cleaned with anything that will remove or dissolve plastic ink
- (7) The projection and the grid junctions with adjoining sheets shall be checked before any other work phase is started on the manuscript.
- (8) The grid intersections, the grid data and the projection data are inked immediately after the checking of the projections and grids
- (9) The intersections locating detail points photo hydro points, and photo (topo) points shall be checked by the supervisor of the graphic compilation section before they are removed from the manuscript
- (10) Unusual features for which no symbol is provided shall be indicated by legend.
- (11) Geographic names of features not delineated on the manuscript shall not be shown on the manuscript but they shall be discussed in the Descriptive Report This may occur for example, where the final name standard shows the name of a group of rocks which have not been inspected in the field and are not discernible on the photographs
- (12) In choosing a suitable size lettering for geographic names, the letters should not be so large and so bold that they detract from the appearance of the manuscript
- (13) In general the first letter of the first word of a descriptive note or legend shall be capitalized

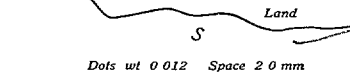

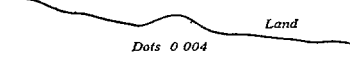
SHORELINE FEATURES		
	Indication on Field Photograph	Manuscript Symbol
<p><i>Storm Water Line</i></p> <p><b>MEAN HIGH WATER LINE</b></p>	<p>Where not clearly visible on photograph MHW line is indicated by frequent dashes</p>  <p>Where not visible on photograph the distance to the MHW line is measured from a distinct parallel line or from nearest identifiable points of detail</p> <p>8.2 m      9 m      7.9 m</p> <p>Where clearly visible on photograph MHW line is confirmed by occasional short dashes</p> 	 <p>Weight 0.012</p>  <p>Weight 0.01 where the shoreline is rocky and of intricate pattern</p>
<p><b>APPROXIMATE MEAN HIGH WATER LINE (Unsurveyed)</b></p>	<p>approx MHWL</p> 	<p>approx MHWL</p> <p>Wt 0.012 Dash 4.0 mm Space 1.0 mm</p>
<p><b>APPARENT SHORLINE</b> Offshore limit of marsh, swamp, or mangrove at mean high water</p>	 <p>Show ticks at junction with fast ground</p>	<p>Weight 0.006</p> <p>Change in line weight must be abrupt</p>
<p><i>Mean</i></p> <p><b>LOW WATER LINE</b> <i>= depth curve of zero depth</i></p>		<p>Wt of dots 0.012 Space 2.0 mm</p>
<p><i>Mean</i></p> <p><b>APPROXIMATE LOW WATER LINE</b> <i>Also awash MHW</i></p>		<p>approx</p> <p>Wt of dots 0.012 Space 2.0 mm</p>
<p><b>SHOAL, REEF, or CHANNEL LINE</b></p>	<p>Rf Shl</p> 	<p>Rf Shl</p> <p>Wt 0.006 Dash 2.0 mm Space 1.0 mm</p>
<p><b>NAVIGABLE CANAL</b> In marsh or swamp</p>	<p>Ca</p> 	 <p>Weight 0.006</p>
<p>In fast land</p>	<p>Ca</p> 	<p>Ca</p> <p>Weight 0.012</p>
<p><b>MUD</b></p>	<p>M</p> 	<p>M Land</p>  <p>Dots wt 0.012 Space 2.0 mm</p>
<p><b>SAND</b> Large areas <i>Over 10 mm long</i></p>		<p>S Land</p>  <p>Dots wt 0.012 Space 2.0 mm</p>
<p>Small areas <i>Between 4.0 mm and 10 mm long</i></p>	<p>S</p> 	<p>S Land</p>  <p>Dots 0.004</p>

3.5

3.1

1.9

2.6

→ this is wrong unless it also is the low water line

FIGURE 5 22—Symbols and abbreviations











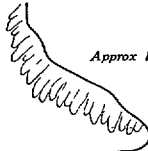

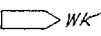



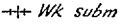

<b>SHORELINE FEATURES</b>		
	Indication on Field Photograph	Manuscript Symbol
<b>ROCK LEDGE</b>	<i>Rk Le</i>	  <i>Approx line wt 0 006'</i>
<b>CORAL</b>	<i>Co</i>	  <i>Approx line wt 0 006'</i>
<b>WRECKS</b>		
Bare at MHW	<i>Wk bare __ft at (Time and date or reference datum)</i>	(3)  <i>Wk</i>
Portion bare at MHW	<i>Wk bare __ft at (Time and date or reference datum)</i>	(2)  <i>Wk</i>
Bare at MLW	<i>Wk uncov __ft at (Time and date or reference datum)</i>	(2)  <i>Wk</i>
Bare or awash (small scale)	<i>Same as for above</i>	 <i>Wk</i> <i>nk-bare</i> <i>Wk - awash</i>
Submerged	<i>Wk subm</i>	 <i>Wk subm</i>
Number of submerged wrecks	<i>Wks subm</i>	 <i>Wks</i>  <i>Wks</i>
<b>FOUL AREAS</b>	<i>Foul</i>	 <i>Foul</i>  <i>Foul</i>
<b>OBSTRUCTION</b>	<i>Obstr</i>	 <i>Obstr</i>  <i>Obstr</i>
<b>BREAKERS</b>	<i>Breakers</i>	 <i>Breakers</i>  <i>Breakers</i>
<b>GRAVEL or BOULDERS</b>	<i>G Bid</i>	 <i>G Bid</i>  <i>G Bid</i>
<b>KELP</b>	<i>Kelp</i>	 <i>Kelp</i>  <i>Kelp</i>

FIGURE 52.—Symbols and abbreviations

SHORELINE FEATURES		
	Indication on Field Photograph	Manuscript Symbol
ROCKS		
Bare at MHW	Bare __ ft at (Time and date or reference datum)	(3) ○ ○ Dot wt 0.02 (0.5 mm) Delineate to scale with size of rock exceeds 0.5 mm
Awash	Uncov __ ft at (Time and date or reference datum)	(1) * * * Wt 0.005" Length 2.0 mm intersecting at 60°
Sunken	Rk subm	+ + + Wt 0.006" Length 2.0 mm intersecting at 90°

APPLICATION OF ROCK DATA

Incorrect	Correct
*	*
⊗	*
×	+
uncovers 6ft MLW *	*(6)
(0) MHW *	* awash MHW
(0) MLW *	* awash MLW
(1) *	* awash MHW
(Pacific coast) (2) *	* awash MHW (Pacific coast)
(1) MLW *	*(1)
1ft below MLW +	* awash MLW
(Pacific coast) 2ft below MLLW +	* awash MLLW (Pacific coast)
2ft above MHW	Rk (2)
6ft above MHW ○	○ (6)
(3) * (5)	*(5)
(3) * * (1)	* awash MHW
(4)	
(2) * * (5)	*(5) Delineate and show elevation for only the highest rock of the cluster
(3)	

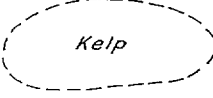
Elevations determined by stereophotogrammetric methods shall be in brackets as (6) instead of parentheses

FIGURE 5-24—Symbols and abbreviations

11

<b>DRAINAGE FEATURES</b>		
	Indication on Field Photograph	Manuscript Symbol
	<i>Delinate feature on photograph where image is not clear</i>	
<b>PERENNIAL STREAM</b> <i>(Non navigable)</i>	<i>Str</i>	 <i>Wt 0 008'' tapered toward head of stream</i>
<b>RIVER</b>	<i>R</i>	 <i>(See SHORELINE FEATURES)</i>
<b>BRAIDED STREAM</b>	<i>Str</i>	 <i>Wt 0 008 tapered toward head of stream</i>
<b>INTERMITTENT STREAM</b>	<i>I Str</i>	 <i>Wt 0 008 tapered toward head of stream Dots 0 008 Dash 4 0 mm Space 1 0 mm</i>
<b>PROBABLE DRAINAGE UNSURVEYED</b>	<i>PDU</i>	 <i>Wt 0 006 Dash 6 0 mm Space 1 0 mm</i>
<b>WASH</b>	<i>Wash</i>	 <i>Limit line wt 0 006'' Dash 2 0 mm Space 1 0 mm</i>
<b>DRAINAGE or IRRIGATION DITCH or CANAL</b>		
Single line	<i>D or Ca</i>	<i>D or Ca</i> <i>Weight 0 01</i>
Double line	<i>D or Ca</i>	 <i>Wt 0 006' Minimum overall width 0 7 mm</i>
<b>INTERMITTENT DRAINAGE or IRRIGATION DITCH or CANAL</b>		
Single line	<i>ID or ICa</i>	 <i>Wt 0 006 Dash 4 0 mm Space 1 0 mm</i>
Double line	<i>ID or ICa</i>	 <i>Wt 0 006 Dash 4 0 mm Space 1 0 mm Minimum overall width 0 7 mm</i>
<b>SLOUGH</b>		
Single line	<i>Slu</i>	 <i>Weight 0 008''</i>
Double line	<i>Slu</i>	 <i>Weight 0 006''</i>

FIGURE 5 25 —Symbols and abbreviations







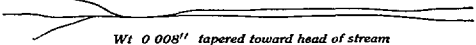
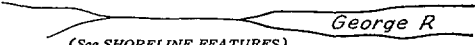
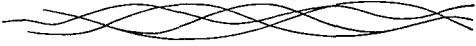
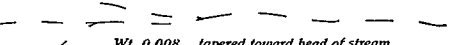
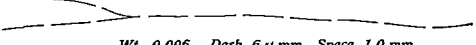
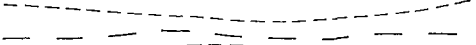
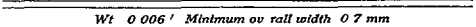
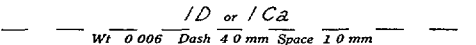
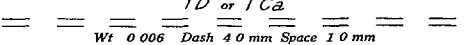
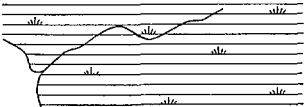
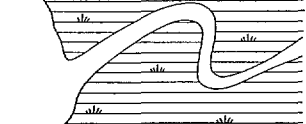





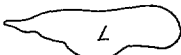





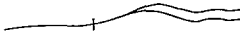

DRAINAGE FEATURES			
	Indication on Field Photograph	Manuscript Symbol	
LAKE or POND	<i>L</i> or <i>P</i>	   <p><i>Wt 0 01'' (Wt 0 006' where bordered by marsh swamp or mangrove)</i></p>	
INTERMITTENT LAKE or POND	<i>IL</i> or <i>IP</i>	   <p><i>omit hatching on topographic and planimetric manuscripts Use legend only</i></p> <p><i>Wt 0 01'' Dash 2 0 mm Space 0 5 mm</i>  <i>(Wt 0 006' where bordered by marsh swamp or mangrove)</i>  <i>Hatching wt 0 006' 1 5 mm apart 45° to bottom of manuscript</i>  <i>Temporary water limits shall not be delineated</i></p>	
SPRINGS	Spring	 Spring <p><i>Wt 0 006</i>      <i>Indicate type of spring such as hot alkali, or sulphur</i></p>	
<i>water tentacles in -ant type</i>	<p><i>Indicate type of spring such as hot alkali or sulphur</i>  <i>Show elevation of springs if for topographic manuscripts</i></p>	 Hot spring <p><i>Wt 0 006</i>      <i>Show elevation of springs on topographic manuscripts</i>  <i>Diam 1 0 mm</i>  <i>Approx to 1</i>  <i>length 2 0 mm</i></p>	
WELL	Well	 Well <p><i>Wt 0 006</i>      <i>Diameter 1 0 mm</i></p>	
FALLS			
Small	<i>Falls</i>	 <p><i>Tick wt 0 008''</i>  <i>Length 1 5 mm</i></p>	
Large	<i>Falls</i>	 <p><i>Ticks wt 0 005</i>  <i>Approx length 1 0 mm</i>  <i>Approx space 0 5 mm</i></p>	
RAPIDS			
Small	<i>Rapids</i>	 <p><i>Tick wt 0 008''</i>  <i>Length 1 5 mm</i>  <i>Minimum space 1 0 mm</i></p>	
Large	<i>Rapids</i>	 <p><i>Ticks wt 0 005'</i>  <i>Average tick length 0 8 mm</i>  <i>Average space 0 5 mm</i></p>	
PERMANENT ICE FIELD or SNOW FIELD	 <p><i>Legend</i></p> <p><i>Contoured or approximately contoured with about the same accuracy as the surrounding terrain</i></p>	 <p><i>Legend</i></p> <p><i>Blue contours with n symbol 1 m ts</i>  <i>Blue limit line wt 0 008</i>  <i>Dash 2 0 mm Space 0 5 mm</i></p>	 <p><i>Legend</i></p> <p><i>Black permanent plastic ink</i></p> <p><i>Express on lines wt 0 005''</i>  <i>Limit line wt 0 008'</i>  <i>Dash 2 0 mm Space 0 5 mm</i></p>
GLACIER	 <p><i>Glacier</i></p>	 <p><i>Glacier</i></p> <p><i>Brown dots wt 0 006'</i></p>	 <p><i>Glacier</i></p> <p><i>Dot wt 0 006</i></p>
GLACIAL MORAINE	 <p><i>Moraine</i></p>	 <p><i>Moraine</i></p> <p><i>Blue form lines wt 0 005</i>  <i>Blue limit line wt 0 008</i>  <i>Dash 2 0 mm Space 0 5 mm</i></p>	 <p><i>Moraine</i></p> <p><i>Expression lines wt 0 005</i>  <i>Limit line wt 0 008'</i>  <i>Dash 2 0 mm Space 0 5 mm</i></p>

FIGURE 5 26—Symbols and abbreviations





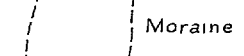



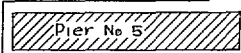

CULTURAL FEATURES		
	Indication on Field Photograph	Manuscript Symbol
PIERS Large	Give name and/or number	 <p style="text-align: right;"><i>Line weights 0.008 unless otherwise noted</i></p>
	Identify small buildings	 <p style="text-align: center;">Dock</p>  <p style="text-align: center;">Wilson Co pier</p>
Small (single line) pier or catwalk		 <p style="text-align: right;"><i>Weight 0.01'</i> <i>Minimum pier length 0.6 mm</i></p>
WHARF	Whf	
SLIP	Slip	
DRY DOCK	Dry Dk	 <p style="text-align: right;"><i>(Drawn to scale)</i></p>
FLOATING DOCK	<del>Floating Dk</del> <i>Floating Dk</i>	 <p style="text-align: right;"><i>(Drawn to scale)</i></p>
PATENT SLIP (MARINE RAILWAY)	Pat slip (Marine Ry)	 <p style="text-align: right;"><i>(Drawn to scale)</i> <i>Dash 1.0 mm Space 0.5 mm</i> <i>Track wt 0.01 Ties Wt 0.005</i> <i>Length 1.0 mm Space 2.5 mm</i></p>
RUINED PIERS	Ruined pier	 <p style="text-align: right;"><i>Dash 1.0 mm Space 0.5 mm</i></p>
PILING IN ROW	Piling	<p style="text-align: center;">piling</p>  <p style="text-align: center;">piling</p> 
DOLPHIN	Dol	Dol
PILE	Pile	Pile •
SUBMERGED PILE	<i>Subm pile</i>	<i>Subm pile</i> •
		<i>Cables Wt 0.005</i> <i>Diameter 0.6 mm</i>

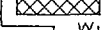
FIGURE 5 27 — Symbols and abbreviations

*CRIB - A STRUCTURE ENCLOSING A WATER INTAKE AND FILTER OFFSHORE IN A LAKE (AS ONE*



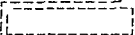







CULTURAL FEATURES		
	Indication on Field Photograph	Manuscript Symbol
<b>JETTIES</b>		
Small	Jetty	 Weight 0 01''
Large	Jetty	 Weight 0 008'
<b>GROINS</b>		
Small	Groin(s)	 Weight 0 008 Min length 0 6 mm Min spacing 0 6 mm
Large	Groin	 Weight 0 01'' Dash 1 0 mm Space 0 5 mm
<b>BREAKWATER</b>	Bkwr	 (Drawn to scale) Weight 0 008'
<b>BULKHEAD</b>	Bkhd	<div style="display: flex; align-items: center;"> <div style="margin-right: 10px;"> <p>Bkhd</p> <p>RV</p> <p>Riprap</p> <p>Se W</p> </div> <div style="font-size: 2em;">}</div> <div style="font-size: 0.8em;"> <p>Indicate character of construction</p> </div> </div>
<b>REVETMENT</b>	RV	
<b>RIPRAP</b>	Riprap	
<b>SEAWALL</b>	Se W	
		Concr Se W
		 Weight 0 008' Distinguish by legend and indicate character of construction
In ruins	Wood bkhd in ruins	 Wood bkhd in ruins Weight 0 008' Dash 1 0 mm Space 0 5 mm
<b>RAMP</b>	Ramp	 Weight 0 008' Dash 1 0 mm Space 0 5 mm
<b>FISH TRAP</b>	Fsh trap	 Fsh trap Weight 0 008' Dash 1 0 mm Space 0 5 mm
<b>NET DRYING RACK</b>	Net rack	 Net rack Weight 0 008' Dash 1 0 mm Space 0 5 mm
<b>FISHING STAKES</b>	Fsh stk	 Fsh stk Weight 0 008 Tick length 1 0 mm Space 0 8 mm
<b>DUCK BLIND</b>	Duck blind	 Duck blind W ght 0 006 Min size 0 6 mm square
<b>STUMP (visible)</b>	Stump	<div style="display: flex; align-items: center;"> <div style="margin-right: 10px;"> <p>Stumps</p> <p>Snags</p> </div> <div style="font-size: 0.8em;"> <p>Circles weight 0 005 Diameter 0 6 mm</p> </div> </div>
<b>SNAG (subm)</b>	Snag	

FIGURE 5 28—Symbols and abbreviations

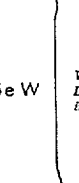
Vertical to see side of opposite p









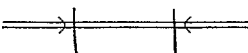

<b>CULTURAL FEATURES</b>				
	<b>Indication on Field Photograph</b>	<b>Manuscript Symbol</b>		
<b>BRIDGES</b> <i>(Over navigable waters)</i>	<i>Give type and clearances Example</i> Lift Br Horiz cl 42 5' Vert cl 9 4' closed WL Vert cl 65 8 open WL 115 PM EST 6-21-48	<i>Give type and clearances Example</i> Lift Br Horiz cl 42 Vert cl MHW Closed 8 -Open 64'		
	Fixed highway	Br	 <i>Tick weight 0 006' Wing tick length 1 0 mm 45° to road</i>	
	Fixed RR	RR Br	 <i>Omit cross ties within bridge symbol and within 6 0 mm of cross tick</i>	
	<i>Give operating regulations of bridges that can be opened Example</i> Closed 6PM to 6AM	<i>Give operating regulations of bridges that can be opened Example</i> Closed 6PM to 6AM		
	Lift	Lift br		
	Bascule	Bascule br		<i>Bridges shall be drawn to scale where possible otherwise they shall be symbolized according to the type of bridge</i>
	Pontoon	Pontoon br		
	Swing bridge or drawbridge in general	Swing br or Drawbridge		
	Foot	Ft br		<i>Weight 0 02''</i>
	<b>CULVERT</b>			
<b>FERRIES</b>				
Small	Fy			
Large	Fy-Sandy Pt to Matapeake		<i>Delineate ferry slips to scale where possible</i>	
<b>FORDS</b>				
Road	Ford <i>F110</i>			
Trail	Ford <i>F11</i>		<i>Dash 2 0 mm Space 1 0 mm</i>	
<b>DAMS</b>				
Small	Dam		<i>Weight 0 015</i>	
Masonry	Masonry dam		<i>Weight 0 015' Delineated to scale with radiating lines (wt 0 006'') as shown</i>	
Carrying road	Rd on dam		<i>Road casing increased by 0 02'' for length of dam</i>	
<b>CANAL LOCK or SLUICE GATE</b> <i>(Drainage or irrigation)</i>	Lock Sluice gate <i>flood gate</i>		<i>Tick weight 0 006'' Length 1 0 mm 45° point upstream</i>	
<b>PASSABLE LOCKS</b> <i>(Navigable)</i>	Locks		<i>Tick weight 0 006' Length 1 0 mm 45° point upstream</i>	

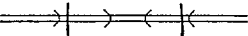
FIGURE 5 29 —Symbols and abbreviations

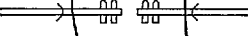

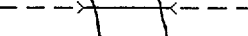
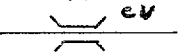
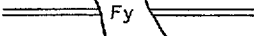
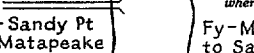
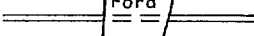
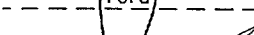

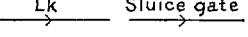
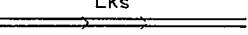

CULTURAL FEATURES		
	Indication on Field Photograph	Manuscript Symbol
TELEPHONE or TELEGRAPH LINE	Tp Line Tel Line	 <p style="text-align: center;">Tp or Tel</p> <p style="text-align: center;"><i>Wt 0 008' Dash 2 5 mm Space 1 2 mm</i></p>
POWER TRANSMISSION LINE	Transm Line	 <p style="text-align: center;">Transm</p> <p style="text-align: center;"><i>Wt 0 008' Dash 2 5 mm Space 1 2 mm Dots 0 02" shown at angle points and after every 6th dash</i></p>
FIREBREAK or OTHER LINE CLEARING	FB	 <p style="text-align: center;">FB or FB</p> <p style="text-align: center;"><i>Wt 0 008' Da h 4 0 mm Space 2 0 mm Minimum width 0 7 mm</i></p>
EXTENSIVE STONE WALL or STONE FENCE	St wall St F	 <p style="text-align: center;">St wall or St F</p> <p style="text-align: center;"><i>Line weight 0 01"</i></p>
LANDMARK FENCE or HEDGE	F Hdg	 <p style="text-align: center;">F or Hdg</p> <p style="text-align: center;"><i>Wt 0 008" Dash 4 0 mm Space 1 0 mm Delineated only where feature constitutes a landmark in an area of sparse culture</i></p>
MISCELLANEOUS LINE FEATURE or AREA <del>ENCLOSURE</del>	Legend	 <p style="text-align: center;">Legend</p> <p style="text-align: center;"><i>Wt 0 008" Dash 1 0 mm Space 0 5 mm</i></p>
CABLE CROSSINGS		<p style="text-align: center;"><i>Cable and pipeline symbol</i></p> <p style="text-align: center;"><i>Wt 0 01' Dash 1 0 mm Space. 0 5 mm</i></p>
Overhead cable with towers (located)	Ovhd cab CI 150' MHW <i>or give clearance with time and date</i>	 <p style="text-align: center;">Ovhd cab CI 150' MHW</p>
Overhead cable with poles (not located)	Ovhd cab CI 120' MHW <i>or give clearance with time and date</i>	 <p style="text-align: center;">Ovhd cab CI 120 MHW</p>
Submerged cable	 <p style="text-align: center;">Subm cab</p>	 <p style="text-align: center;">Subm cab</p>
Submerged pipeline <del>crossing</del>	 <p style="text-align: center;">Subm pipeline</p>	 <p style="text-align: center;">Subm pipeline</p>
LEADING LINE (RANGE)	Rge	 <p style="text-align: center;">Glebe Pt Rge</p> <p style="text-align: center;"><i>Weight 0 01" Dash 1 0 mm Space 1 0 mm</i></p>

FIGURE 5 30—Symbols and abbreviations

<b>CULTURAL FEATURES</b>		
	<b>Indication on Field Photograph</b>	<b>Manuscript Symbol</b>
<p style="text-align: center;"><i>Give (1) classification (2) number of lanes if other than two and (3) Federal or State route number</i></p> <p style="text-align: center;"><i>Scale permitting delineate all roads correctly positioned Road casings wt 0 008' except where noted</i></p>		
<b>ROADS</b>	<b>Class 1</b> Hard surface heavy duty four or more lanes	Rd 1 L6    Rd 1 L6D
		Rd 1 L3
		Rd 1 L3
	<b>Class 2</b> Hard surface heavy duty two or three lanes	Rd 2    Rd 2 L3
	<b>Class 3</b> Hard surface medium duty four or more lanes	Rd 3 L6    Rd 3 L6D
		Rd 3 L3
		Rd 3 L3
	<b>Class 4</b> Hard surface medium duty two or three lanes	Rd 4    Rd 4 L3
<b>Class 5</b> Loose surface graded and drained single lane hard surface streets	Rd 5    Rd 5 L1 hard surface	
<b>Class 6</b> Improved dirt road	Rd 6	
<b>Class 7</b> Unimproved dirt road private road abandoned road	Rd 7    priv    aband	
<b>Class 8</b> Important foot paths foot trails pack trails	Tr	
<b>Under construction</b>	<i>Classification and notes the same as for the finished road and add Under const</i>	

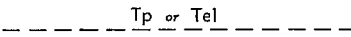
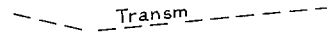
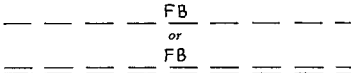
FIGURE 5 01—Symbols and abbreviations

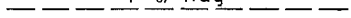

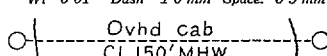
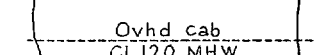
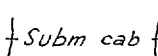
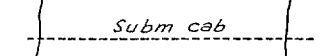
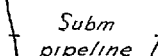
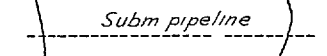
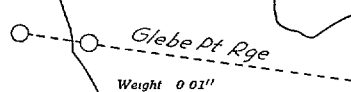







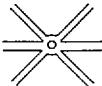

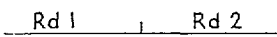
CULTURAL FEATURES		
	Indication on Field Photograph	Manuscript Symbol
TRAFFIC CIRCLE	Traffic circle	 <p><i>Actual shape scale permitting</i>                      Min. outside diam 3 0 mm                      Min. inside diam                      2 and 3 lanes 2 0 mm                      4 or more lanes 1 0 mm</p>
CLOVERLEAF <i>(11-12 m wide pass)</i> <i>(with 5 m wide pass)</i>	 <p style="text-align: center;">(Cloverleaf)</p>	 <p><i>Actual shape scale permitting</i>                      Min. outside dimension of square                      2 and 3 lanes 3 0 mm                      4 or more lanes 5 0 mm</p>
FEDERAL HIGHWAY NUMBERS	US 50	US 50
STATE HIGHWAY NUMBERS	Va 121	Va 121
CHANGE IN ROAD CLASSIFICATION		 <p style="text-align: center;">Rd 1      Rd 2</p> <p><i>Tick wt 0 008    Length 1 5 mm</i></p>
CHANGE IN NUMBER OF LANES		 <p style="text-align: center;">4 Lanes      6 Lanes</p> <p><i>Tick wt 0 008    Length 1 5 mm</i></p>
ROAD OBJECTIVES <i>(Topographic manuscripts only)</i>		<p>12 Mi to Joppa 5 4 Mi to US 90</p>  <p><i>Destination 6 pt lettering</i>  <i>Arrow line wt 0 01</i>  <i>Length varies</i>  <i>Arrowhead 1 0 mm x 3 0 mm</i></p>
GRADE CROSSING		 <p style="text-align: right;"><i>Space 0 5 mm</i></p>
UNDERPASS and OVERPASS		
DEAD END STREET <i>(Road ends)</i> <i>(Road continues)</i>		
TUNNEL	Tunnel	 <p><i>Tick wt 0 006'</i>  <i>Wing tick length 1 0 mm 45° to road</i></p>
VIADUCTS or BRIDGES <i>(Over non-navigable water)</i>	Viaduct Br	<p><i>Not symbolized if under 300 ft long</i>  <i>except in areas of very sparse culture</i></p> 
Highway		
Single RR		 <p><i>Wing tick wt 0 006'</i>  <i>Wing tick length</i>  <i>1 0 mm 45° to road</i></p>
Double RR		 <p><i>Omit cross ties within</i>  <i>bridge symbol and</i>  <i>within 5 0 mm of</i>  <i>cross tick</i></p>

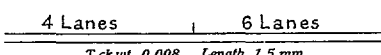
FIGURE 5 32—Symbols and abbreviations

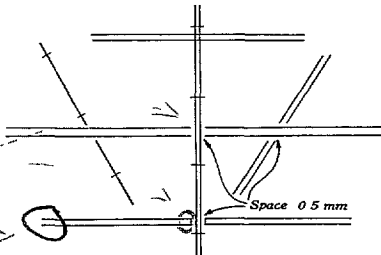
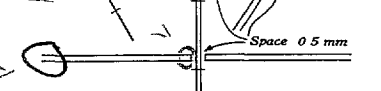
<b>CULTURAL FEATURES</b>		
	Indication on Field Photograph	Manuscript Symbol
<b>RAILROADS</b>		<i>Wt of single track 0 01 Wt of double track 0 008</i> <i>Interval between cross ties 10 mm</i> <i>Cross ties Wt 0 006" Length extends 0 3 mm beyond track</i>
Single track	RR (1)	
Double track	RR (2)	
Two different railroads side by side	<i>Distinguish by legend</i>	
Multiple track	RR (5)	<p style="text-align: center;">5 tracks</p>
Change in number of tracks	RR (3)   RR (4) <i>Place tick at change in number of tracks</i>	<p style="text-align: center;">3 tracks      4 tracks</p> <p style="text-align: center;"><i>Show main line and limit ng tracks correctly positioned</i> <i>All other tracks are symbollic</i></p>
Yard	RR Yard	
Narrow gage		<i>Tracks generalized Approx 0 8 mm between tracks</i> <i>Length of cross ties Approx 2 5 mm</i>
Single track	Narrow gage RR (1)	
Double track	Narrow gage RR (2)	
Abandoned	Aband RR	
Dismantled (RR or carline)	Dismantled RR	Dismantled RR Dash 1 2 mm Space 0 5 mm
Under construction	RR Under Const	
RR in street		
Station	RR Sta	
Roundhouse	RR Roundhouse	
Turntable	RR Turntable	
<b>CARLINE (INTERURBAN RAILWAY)</b>	Carline	<p style="text-align: center;">Interval between cross ties 5 0 mm</p> <p style="text-align: center;"><i>Shown only cross country and where not coincident with streets or roads</i></p>

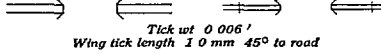
FIGURE 5 33—Symbols and abbreviations

CULTURAL FEATURES		
	Indication on Field Photograph	Manuscript Symbol
<b>CLASS 1 BUILDINGS</b>	<p><i>Outline obscured buildings or those erected after the photographs were taken make necessary deletions and classify all buildings except those in Class 1</i></p>	<p>Minimum size 0.6 by 0.6 mm</p> <p>No side exceeding 6.0 mm</p> <p>Any side exceeding 6.0 mm Line weights 0.006" Crosshatching 1.5 to 2.5 mm apart at 45° to side of building</p> <p>Insignia wt 0.005" Upright 1.5 mm Staff 1.5 mm Crosspiece 0.8 mm located 0.5 mm from top of upright Pennant 0.6 by 1.0 mm</p> <p>Elongation of staff and upright</p> <p>Change in position of staff and upright</p> <p>Central HS St Pauls Ch <i>(All schools and churches regardless of size delineated in solid black)</i></p>
Small		
Large		
Unusually large		
Schools and churches		
Central HS St Pauls Ch		
Central HS St Pauls Ch		
Central HS St Pauls Ch		
Central HS St Pauls Ch		
Central HS St Pauls Ch		
<b>CLASS 2 BUILDINGS</b>	<p>2</p> <p>2</p> <p>2</p>	<p>Minimum size 0.6 by 0.6 mm Wt 0.006"</p> <p>No side exceeding 1.5 mm Wt 0.006"</p> <p>Any side exceeding 1.5 mm Line weights 0.006" Hatching 1.0 to 2.5 mm apart at 45° to side of building</p>
Small		
Large		
Unusually large	2	Any side exceeding 1.5 mm Line weights 0.006" Hatching 1.0 to 2.5 mm apart at 45° to side of building
<b>RUINS</b>	<p>Ruins</p> <p>Ruins</p>	<p>Minimum size 0.6 by 0.6 mm Wt 0.006" <i>(Delineate only in areas of sparse culture)</i></p> <p>Any side exceeding 0.6 mm Wt 0.006" Dash 1.0 mm Space 0.5 mm</p>
Small		
Large	Ruins	Ruins
<b>CIRCULAR TANKS</b>	<p><i>Indicate material stored i.e. gas oil water vinegar etc</i></p>	<p>• Legend Minimum diameter 0.6 mm</p> <p>● Legend Diameter not exceeding 2.0 mm</p> <p>⊘ Legend Diameter exceeding 2.0 mm Line weights 0.006" Hatching 1.0 to 2.5 mm apart at 45° to bottom of manuscript</p>
Small		
Large		
Unusually large		
<b>HORIZONTAL TANKS</b>	<p><i>Indicate material stored i.e. gas oil water vinegar etc</i></p>	<p>— Legend Minimum length 1.0 mm Wt 0.008"</p> <p>≡ Legend Wt 0.008"</p> <p>⊘ Legend Exceeding 0.5 mm width and 2.0 mm length Line weights 0.006" Hatching 0.5 mm apart at 45° to long side of symbol</p>
Small		
Group		
Large		
<b>WELLS</b>	<p>Oil well</p> <p>Gas well</p> <p><i>For water well see DRAINAGE FEATURES</i></p>	<p>○ Oil well Minimum diameter 1.0 mm Wt 0.006"</p> <p>○ Gas well Minimum diameter 1.0 mm Wt 0.006"</p>
Oil		
Gas		

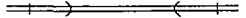
FIGURE 5 34—Symbols and abbreviations











<b>CULTURAL FEATURES</b>		
	<b>Indication on Field Photograph</b>	<b>Manuscript Symbol</b>
<b>EXCAVATIONS</b>	<i>Outline the limits of all area features</i>	
Mine	Mine	 Legend
Quarry	Quarry	 Legend
Borrow pit	Borrow pit	<i>Outlined to scale</i> Wt 0 006' Dash 1 0 mm Space 0 5 mm
Open mine or quarry	Mine Quarry	 Legend
Shaft or tunnel opening	Shaft Tunnel opening	<i>When not outlined to scale</i> Cross lines 2 5 mm Weight 0 006
<b>CEMETERIES</b>		
Small	Cem	 Legend
	Cem	<i>Square 1 2 mm Line weight 0 006'</i>
	Cem	 Cem
	Cem	<i>Minimum size 1 5 by 1 5 mm Wt 0 006'</i> Dash 1 0 mm Space 0 5 mm
	Cem	 Cem
	Cem	<i>Small cemetery with cultural boundaries</i> Cross wt 0 006 Variable size
	Cem	 Cem
	Cem	<i>Wt 0 006' Dash 1 0 mm Space 0 5 mm</i>
	Cem	 Cem
	Cem	<i>Where the legend cannot be placed within the cemetery limits use appropriately sized cross</i>
Large	Cem	 Greenwood Cem
	<i>Indicate name</i>	<i>Name large cemeteries</i> Wt 0 006' Dash 1 0 mm Space 0 5 mm Delineate principal roads within cemeteries 20 by 20 mm or larger
<b>FAIRGROUNDS, AMUSEMENT PARK, ZOO, etc</b>	Fairgrounds Amusement park Zoo	 Fairgrounds
	<i>Indicate name</i>	<i>Outline to scale</i> Wt 0 006 Dash 1 0 mm Space 0 5 mm Delineate structures in accordance with their classification Indicate name
<b>GOLF COURSE</b>	Golf course	 Golf course
	<i>Indicate name</i>	<i>Outline to scale</i> Wt 0 006 Dash 1 0 mm Space 0 5 mm Delineate structures in accordance with their classification Omnit traps and greens Indicate name
<b>BALL PARK</b>	Ball park	 Ball park
	<i>Indicate name</i>	<i>Outline to scale</i> Wt 0 006' Dash 1 0 mm Space 0 5 mm Delineate structure in accordance with its classification Indicate name
<b>STADIUM</b>	Stadium	 Stadium
	<i>Indicate name</i>	<i>Outline to scale</i> Wt 0 006 Dash 1 0 mm Space 0 5 mm Delineate structure in accordance with its classification Indicate name
<b>RACE TRACK</b>	Race track	 Race track
	<i>Indicate name</i>	<i>Outline to scale</i> Wt 0 006 Dash 1 0 mm Space 0 5 mm Delineate structures in accordance with their classification Indicate name
<b>AIRPORT</b>	<i>Give name of airport and identify location of aeronautical aids</i>	 Greenwood Field
		<i>Limits wt 0 006 Dash 1 0 mm Space 0 5 mm</i> <i>Runways and taxiways wt 0 008'</i> <i>Delineate structures according to their classification</i>

FIGURE 5 35—Symbols and abbreviations





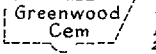
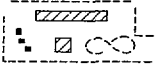
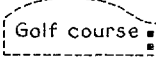

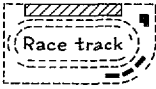
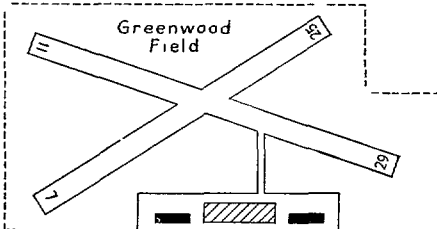

VEGETATION AND SWAMP LIMITS			
	Indication on Field Photograph	Manuscript Symbol	
		Topographic & Planimetric	Shoreline
MARSH Salt Fresh	Ma	<p><i>Outline and legend in blue permanent plastic ink Wt 0 008' Dash 2 5 mm Space 0 5 mm</i></p> 	<p><i>Black permanent plastic ink Space between lines of symbols 1 5 mm Weight 0 006''</i></p> 
		<p><i>Legend</i></p> 	
SWAMP or CYPRESS SWAMP	Sw Cy Sw		
GRASS IN WATER	Grs W		
GLADE LAND	Glade land		
LOW AREA or AREA OF SEASONAL INUNDATION	fls		
CRANBERRY BOG	CB	 <p><i>Blue permanent plastic ink Wt 0 01''</i></p>	 <p><i>Weight 0 01''</i></p>
SALT EVAPORATOR	Salt evaporator	 <p><i>Blue permanent plastic ink Wt 0 01''</i></p>	 <p><i>Weight 0 01''</i></p>

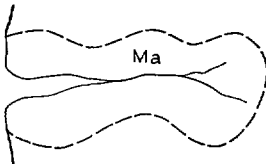
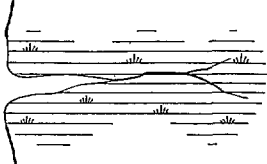
FIGURE 5 36—Symbols and abbreviations

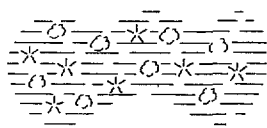
WOODLAND COVER			
	Topographic Manuscript		
	Indication on Field Photograph	Manuscript Symbol	
		<i>Classify occasional characteristic areas Outline only where necessary</i>	
WOODS	T		
SCRUB	S		
ORCHARD	O		
VINEYARD MANGROVE or OTHER LARGE STANDS OF SPECIAL GROWTH	V Mg <i>Legend</i>		
Planimetric and Shoreline Manuscript			
	Indication on Field Photograph	Manuscript Symbol	
		Planimetric	Shoreline
	<i>Classify occasional characteristic areas Outline only where necessary</i>		
DECIDUOUS TREES	TH		
EVERGREEN TREES	TS		
MIXED WOOD*	TM		
ORCHARD NURSERY VINEYARD	O Nu V		
CYPRESS*	Cy		
PALM	Palm		
PALMETTO	Palmetto		
MANGROVE	Mg		

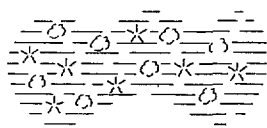
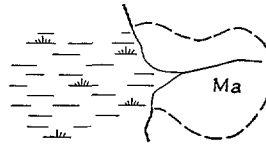
FIGURE 5 37—Symbols and abbreviations

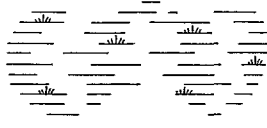
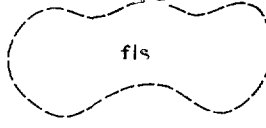
GS does not use this symbol nor do they make a distinction between Cy Sw and just plain Sw.

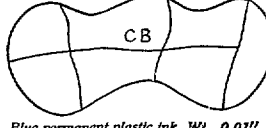
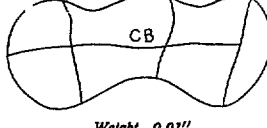
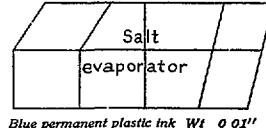
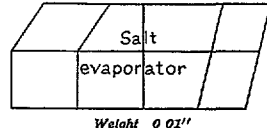

RELIEF FEATURES			
	Indication on Field Photograph	Manuscript Symbol	
		Topographic	Planimetric & Shoreline
<i>Brown waterproof ink</i> <i>Brown permanent plastic ink</i> <i>Contour elevations 6 point</i> <i>inclined numerals</i> <i>Black permanent plastic ink</i>			
<b>CONTOURS</b>			
Index			
Intermediate			
Supplemental			
Approximate Index			
Intermediate			
Form lines			
Depression			<i>Use of hachures to indicate relief is shown in figure 5 E</i>
Feathered			
Carrying (Merging)			

FIGURE 5 38—Symbols and abbreviations

<b>RELIEF FEATURES</b>			
	Indication on Field Photograph	Manuscript Symbol	
		Topographic	Planimetric & Shoreline
<b>CONTOURS (Cont d)</b>	<i>Contours in brown waterproof ink</i>	<i>Contours in brown permanent plastic ink</i>	<i>Black permanent plastic ink</i>
Crossing single line stream			
Omitted for double line stream <i>Dont omit</i>			
Turning into canal			
Under over-passing viaduct			<i>close</i>
Crossing paved or graded strip, such as roads or railroads			
<b>CUT</b> <i>illustrated with symbols</i>			
<b>FILL</b>			

FIGURE 5 39 — Symbols and abbreviations









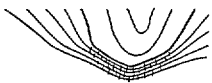
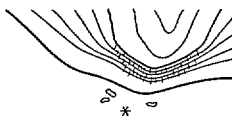

RELIEF FEATURES			
	Indication on Field Photograph	Manuscript Symbol	
		Topographic	Planimetric & Shoreline
<b>ROCKY BLUFF</b> <i>(Landmark feature)</i> <i>cliff - rocky bluff</i>	<i>Contours in brown waterproof ink</i> 	<i>Contours in brown permanent plastic ink</i>  <i>Tick wt 0 006' Length varying</i> <i>Brown plastic ink</i>	<i>Black permanent plastic ink</i>  <i>Tick wt 0 006' Length varying</i>
<b>BLUFF</b> <i>(Landmark feature)</i> <i>(Other than rocky)</i>			 <i>Hachures as shown</i> <i>Length and weight varies</i> <i>(See figure 5 8)</i>
<b>SAND DUNES</b>	<i>S dunes</i> 	<i>S dunes</i>  <i>Dots wt 0 012' Space 2 0 mm</i>	 <i>Dot weights 0 012' &amp; 0 004''</i> <i>(0 012'' dots indicate shape of crest)</i>
<b>Shifting</b>	<i>Shifting S dunes</i>	<i>Shifting S dunes</i>  <i>Dots wt 0 012' Space. 2 0 mm</i>	<i>Shifting S dunes</i>  <i>Dots wt 0 004'</i>
<b>LEVEES</b>			
<b>Contoured</b>  <b>spill</b>		 <i>Ca</i> <i>Contoured where possible without displacing either feature</i>	 <i>Ca</i> <b>spill</b>
<b>Symbolized</b>	<i>Lev</i>	<i>Lev</i> <i>Weight 0 015</i> <i>Brown permanent plastic ink</i>	
<b>Close to canal</b>		 <i>(5 contour)</i>	 <i>Ca</i>
<b>With road</b>		 <i>(5 contour)</i> <i>Rd 5</i> <i>0 01' Brown</i> <i>(15 contour cross ing)</i>	 <i>Rd 5</i>
<b>With railroad</b>	<i>RR on Lev</i>	 <i>0 01'' Brown</i>	

FIGURE 5 40—Symbols and abbreviations

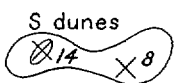
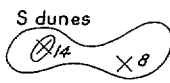

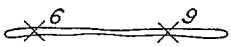
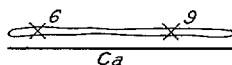
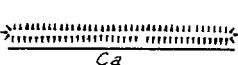

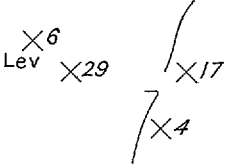
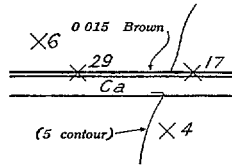
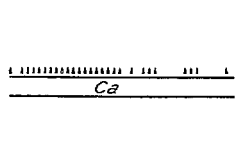
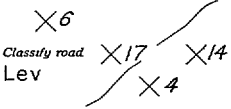
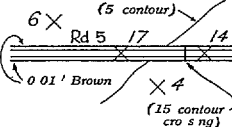
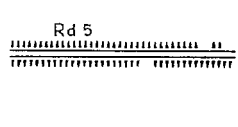
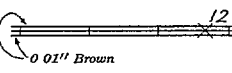
<b>CONTROL POINTS</b>			
	<b>Indication on Field Photograph</b>	<b>Indication on Office Photograph</b>	<b>Manuscript Symbol</b>
<b>HORIZONTAL POINTS</b>	<p><i>Waterproof ink Freehand symbols</i></p> <p><b>Horizontal control point of 3rd order accuracy or better</b> <i>Where same point is also a bench point add legend (BM or VABM) and elevation</i></p> 	<p><i>Washable pigment ink color to contrast with tone of photograph</i> <i>Compass circles Ruled lines</i></p> 	<p><i>Black permanent plastic ink except where others are noted</i> <i>6 point freehand lettering</i></p>  <p><i>Wt 0.008" 4.5 mm sides</i> <i>Where same point is also a bench point add legend (BM or VABM) and elevation</i></p>
	<p><b>Substitute point</b></p> 		 <p><i>(Station name used only where necessary to avoid confusion)</i> <i>Wt 0.008" 2.5 mm c rcle and note in red permanent plastic ink on back</i></p>
	<p><b>Topographic point</b> <i>Located by planetable or theodolite fix</i></p> 		 <p><i>Wt 0.008" 2.5 mm circle</i></p>
	<p><b>Azimuth point or Fixed aid to navigation</b></p> 		 <p><i>Wt 0.008" 2.5 mm circle</i> <i>Name and/or number to be shown in accordance with Light List</i></p>
	<p><b>Landmark</b></p> 		 <p><i>Wt 0.008" 2.5 mm circle</i></p>
	<b>PHOTOGRAMMETRIC POINTS</b>	<p><b>Photo (topo) point</b></p> 	
<p><b>Azimuth point or Fixed aid to navigation</b></p> 			 <p><i>Wt 0.008" 2.5 mm circle</i> <i>Name and/or number to be shown in accordance with Light List</i></p>
<p><b>Landmark</b></p> 			 <p><i>Wt 0.008" 2.5 mm c rcle</i></p>





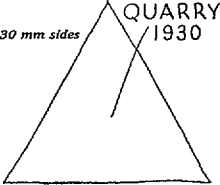
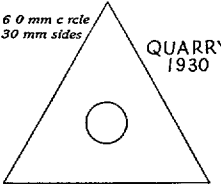
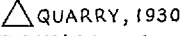
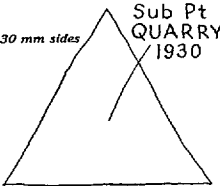
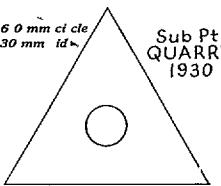

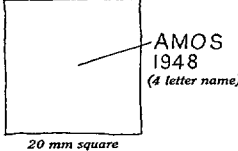
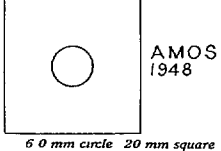
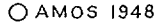
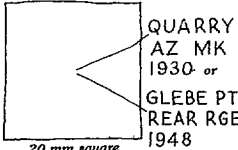
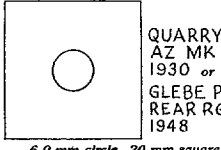
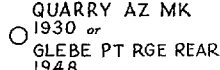
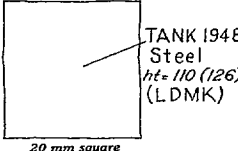
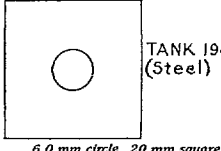
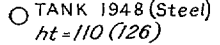
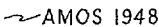
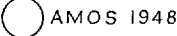
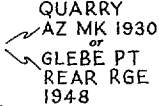
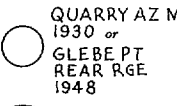
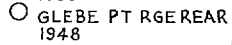
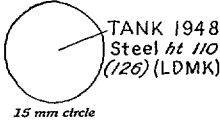
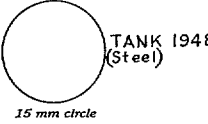
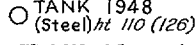
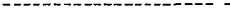
FIGURE 5 41 —Symbols and abbreviations

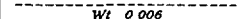
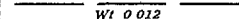
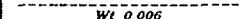
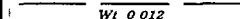
<b>CONTROL POINTS</b>			
	Indication on Field Photograph	Indication on Office Photograph	Manuscript Symbol
<b>PHOTOGRAMMETRIC POINTS (Cont d)</b>	<i>Waterproof ink. Freehand symbols</i>	<i>Washable pigment ink color to contrast with tone of photograph Compass circles Ruled lines</i>	<i>Black permanent plastic ink except where otherwise noted 6 point freehand lettering Vertical figures except where otherwise noted</i>
Photo hydro point	871 (Three digits)	871 6.0 mm circle	871 <i>Wt 0.008' 2.5 mm circle</i>
Pass point		6.0 mm circle <i>Radial line where required</i>	6.0 mm circle <i>Blue permanent plastic ink on back</i>
Detail point		4.0 mm circle	2.5 mm circle <i>Blue waterproof ink on back</i>
Radial, conjugate, and substitute centers		6.0 and 10 mm circles	6.0 and 10 mm circles <i>Blue translucent ink on back</i>
<b>VERTICAL POINTS</b>			
Monumented bench point	BM F46 38 14 <i>6.0 mm circle</i>	BM F46 38 <i>6.0 mm circle</i>	BM F46 38 <i>Symbol wt 0.008' 5.0 mm lines</i>
Non-monumented bench point	38 14 <i>6.0 mm circle</i>	38 <i>6.0 mm circle</i>	38 <i>Symbol wt 0.008' 5.0 mm lines</i>
Vertical angle bench point	VABM F46 38 14 <i>6.0 mm circle</i>	VABM F46 38 <i>6.0 mm circle</i>	VABM F46 38 <i>Symbol wt 0.008' 5.0 mm lines</i>
Tidal bench point	TBM No 2 <i>6.0 mm circle</i>	TBM No 2 <i>6.0 mm circle</i>	TBM No 2 <i>Symbol wt 0.008' 5.0 mm lines</i>
Spot point	<i>Identifiable Unidentifiable</i>		<i>Identifiable Unidentifiable</i>
Checked	48 3 <i>Symbol 4.0 mm brown Elevations Blue inclined</i>	48 3	48 <i>Symbol 3.0 mm brown Elevations Black inclined</i>
Unchecked	48 3 <i>Symbol 4.0 mm brown Elevations Brown inclined</i>	48 3	48 <i>Symbol 3.0 mm brown Elevations Brown inclined</i>
Photo elevation point (unchecked)	48 <i>Symbol 4.0 mm brown Elevations Inclined underscored</i>	48 <i>Symbol 4.0 mm brown Elevations Inclined underscored</i>	48 <i>Symbol 3.0 mm brown Elevations Brown inclined underscored</i>
<b>OTHER POINTS</b>			
Sextant fix	<i>Sextant fix angles and objects listed on back of photograph</i>		2.5 mm red permanent plastic ink circle on back of manuscript Show number of fix or name of object located Where possible symbolize located object on face of manuscript

FIGURE 5 42—Symbols and abbreviations

<b>LIMIT LINES</b>			
	Indication on Field Photograph	Topographic & Planimetric Manuscript Symbol	Shoreline Manuscript Symbol
<b>AIRPORT, PARK, CEMETERY, etc</b>  <b>URBAN AREA</b>	<i>Waterproof ink Ruled lines</i>    	<i>Black permanent plastic ink</i>   <i>Wt 0 006</i> <i>Dash 10 mm Space 0 5 mm</i>   <i>Wt 0 012</i> <i>Dash 10 mm Space 2 0 mm</i>	<i>Black permanent plastic ink</i>   <i>Wt 0 006</i> <i>Dash 10 mm Space 0 5 mm</i>   <i>Wt 0 012</i> <i>Dash 10 mm Space 2 0 mm</i> <i>Used on shoreline manuscripts only</i> <i>when specifically required by project</i> <i>instructions</i>

### STATION NAMES (SPECIAL CASES)

	Manuscript Symbol
<b>FIXED AID TO NAVIGATION</b> <i>Where also a triangulation station and the station name differs from the Light List name</i>	 GLEBE POINT LIGHT <i>Light List name first</i>  (GLEBE PT LIGHTHOUSE 1930) <i>Station name in parentheses</i>
<b>LANDMARK</b> <i>(1) Where a landmark is a triangulation station and the station name indicates it is a prominent object</i>	 MARTIN CO TANK 1947 <i>Station name first</i>  (Steel 110 ft high) <i>Data from field description in parentheses</i>
<i>(2) Where a landmark is a triangulation station and the station name does not indicate it is a prominent object</i>	 TANK Steel 110 ft high <i>Name from field description</i>  (MARTIN, 1947) <i>Station name in parentheses</i>

### STATION SYMBOLS ON MANUSCRIPT

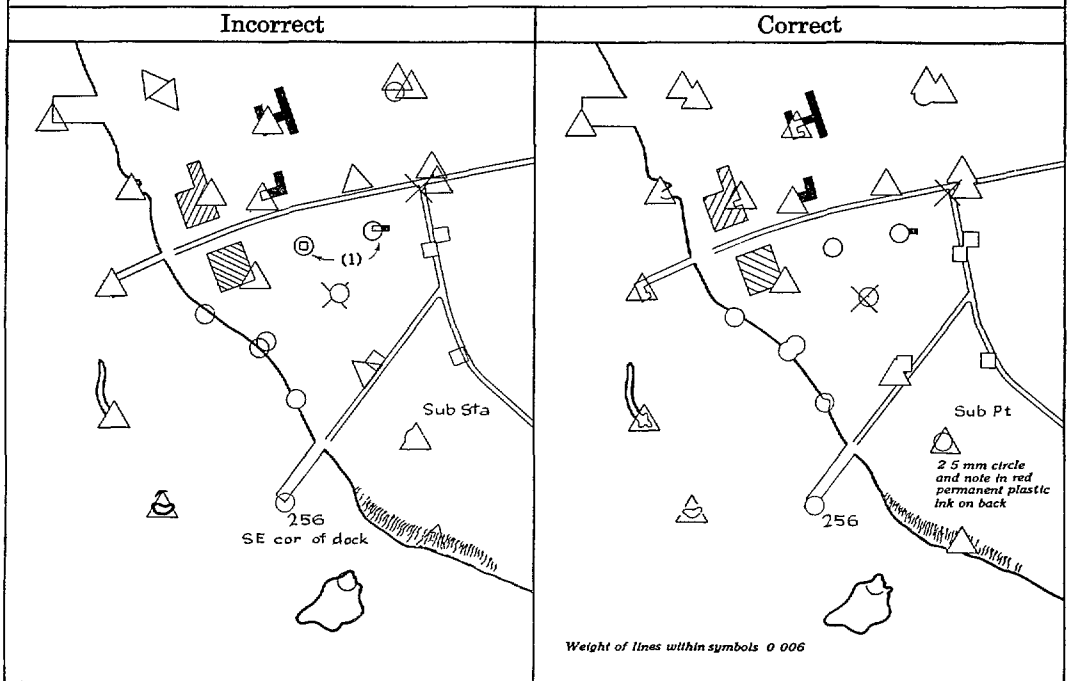

(1) Note On topographic manuscripts this symbolization is correct

FIGURE 5 43—Symbols and abbreviations

<b>BOUNDARIES</b>			
	Indication on Field Photograph	Manuscript Symbol	
		Topographic & Planimetric	Shoreline
<b>NATIONAL</b>	<i>Waterproof ink Ruled symbols</i> -----	<i>Red permanent plastic ink except where otherwise noted</i> ----- <i>Wt 0 02' Long dash 7.5 mm</i> <i>Short dash 2.0 mm Space 1.0 mm</i>	<i>Black permanent plastic ink</i> -----
<b>STATE</b>	-----	<i>Wt 0 015' Long dash 7.5 mm</i> <i>Short dash 2.0 mm Space 1.0 mm</i>	-----
<b>COUNTY or PARISH</b>	-----	<i>Wt 0 012' Long dash 7.5 mm</i> <i>Short dash 2.0 mm Space 1.0 mm</i>	-----
<b>MAJOR COUNTY SUBDIVISION (Political or Civil)</b>	-----	<i>Wt 0 011'</i> <i>Dash 5.0 mm Space 1.0 mm</i>	-----
<b>CORPORATE LIMITS</b>	-----	<i>Wt 0 008' Long dash 2.0 mm</i> <i>Short dash 1.0 mm Space 1.0 mm</i>	-----
<b>RESERVATION (National, State or Military)</b>	-----	<i>Wt 0 011' Dash 7.5 mm</i> <i>Dots 0 012' centered in 3.0 mm space</i>	-----
<b>BOUNDARY MONUMENT</b>	<input type="checkbox"/> Mon 5.0 mm square	<input type="checkbox"/> Mon <i>Wt 0 008'</i> <i>2.0 mm square</i> <i>Black permanent plastic ink</i>	<input type="checkbox"/> Mon <i>Wt 0 008'</i> <i>2.0 mm square</i>
<b>PUBLIC LAND LINES</b>			
	Indication on Field Photograph	Indication on Office Photograph	Topographic & Planimetric Manuscript Symbol
<b>*TOWNSHIP LINE</b>	<i>Waterproof ink Ruled symbols</i> -----		<i>Red permanent plastic ink</i> ----- <i>Weight 0 012''</i>
<b>Reliable</b>	-----		-----
<b>Unreliable</b>	-----		<i>Weight 0 012''</i> <i>Dash 2.5 mm Space 0.5 mm</i>
<b>SECTION LINE</b>	-----		-----
<b>Reliable</b>	-----		<i>Weight 0 006''</i>
<b>Unreliable</b>	-----		<i>Weight 0 006''</i> <i>Dash 2.5 mm Space 0.5 mm</i>
<b>LAND GRANT LINE</b>	-----		-----
<b>TRUE (ORIGINAL) RECOVERED STANDARD CORNER</b>			 <i>2.0 mm square and cross Wt 0 008'</i> <i>1.0 mm clearance between corner symbol and land line</i>
<b>ACCEPTED STANDARD CORNER</b>			 <i>2.0 mm circle and cross Wt 0 008'</i> <i>1.0 mm clearance between corner symbol and land line</i>
<b>THEORETICAL CORNER (Not recovered)</b>			

\*Includes principal meridians guide meridians base lines standard parallels and treaty lines

FIGURE 5 44—Symbols and abbreviations

# ABBREVIATIONS

*The use of abbreviations is optional. When abbreviations are used however they should be as listed although the use of capitals is not always rigidly adhered to.*

abandoned	aband	electric	elec	mean high water	MHW
aeronautical	AERO	elevation elevated elevator	elev	mean higher high water	MHHW
altitude	alt	entrance	Entr	mean low water	MLW
anchorage	Anch	embankment	emb	mean lower low water	MLLW
approximate	approx	established	estab	mean sea level	MSL
astronomical	Astro	existence doubtful	ED	mean tide level	MTL
avenue	Ave	factory	Facty	meter(s)	m
azimuth mark	Az Mk	fathom	fm	mile(s)	mi
bank	Bk	fence	F	millimeters(s)	mm
barn	Ba	ferry	Fy	minute(s)	min
bay bayou	B	firebreak	FB	mixed (woods)	M
beacon	Bn	fishing stakes	Fsh stk	monument	MON
bench mark	BM	fixed	F	mount mountain	Mt
black	B	fixed and flashing	F FI	mud	M
blue	Bu	ford	Fd	north	N
blueberry barren	BB	flagpole	FP	northeast	NE
bluff	Blf	flagstaff	FS	northwest	NW
boulder(s)	Bld	flashing	Fl	north northeast	NNE
boulevard	Bldv	flood flooded	fl	north northwest	NNW
boundary	Bdy	foot feet	ft	number	No
breakwater	BKW	gable	GAB	nursery	Nu
bridge	Br	government	Govt	obstruction	Obstr
brown	Br	grass	Grs	orchard	O
brush	B	grass in water	Grs W	overhead	OVHD
building	Bldg	gravel	G	oysters	Oys
bulkhead	Bkhd	green	G	pass passage	Pass
cable	Cab	ground	Grd	patent slip	Pat Slip
canal	Ca	harbor	Hbr	marine railway	Marine Ry
cape	C	hard	hrd	pavilion	Pav
capitol	Cap	head	Hd	peak	Pk
cathedral	Cath	hedge	Hdg	peninsula	Pen
cemetery	Cem	height	ht	photo hydro station	Photo Hydro Sta
centimeter(s)	cm	high school	HS	pilot station	PIL STA
channel	Chan	high water	HW	point	Pt
checkered	chec	higher high water	HHW	pond	P
chimney	CHY	highway	Hy	position	Pos
church	Ch	horizontal	Hor	position approximate	PA
clearance	CL	hospital	Hosp	position doubtful	PD
Coast Guard station	CG	hour(s)	hr	post office	PO
company	Co	house	Ho	power station	P Sta
concrete	concr	inch inches	in	private privately	priv
conspicuous	conspic	institute	Inst	probable drainage unsurveyed	PDU
construction	Const	intermittent pond	IP	prominent	prom
coral	Co	intermittent stream	I Str	radio	R
corner	cor	irregular	Irreg	railroad	RR
corporation	Corp	island	I	railroad station	RR Sta
correction	cor	islet	It	railway	Ry
county	Co	jetty	Jet	range	Rge
courthouse	CH	kilometer	km	red	R
cove	C	knot	kn	reef	Rf
cover(s)	cov	lagoon	Lag	reference mark	RM
cranberry bog	CB	lake	L	reflector	REF
creek	Cr	landmark	Ldmk	reservoir	Res
culvert	Cv	landing	Ldg	retaining wall	Ret W
cupola	CUP	large	lrg	river	R
customhouse	Cus Ho	latitude	lat	road	Rd
degree(s)	deg	ledge	Le	rock	Rk
described	d	levee	Lev	rocky	rky
described and marked	dm	lifesaving station	LSS	sand	S
destroyed	D	light	Lt	school	Sch
distance distant	dist	lighthouse	LH	sea wall	Se W
ditch	D	longitude	long	second(s)	sec
dock	Dk	lookout tower	LOOK TR	shells	Sh
dolphin	Dol	low water	LW	shoal	shl
doubtful	D	lower low water	LLW	slough	slu
east	E	maintained	maintd	small	sml
east northeast	ENE	mangrove	Mg	soft	sft
east northwest	ENW	marsh	Ma	Sound	Sd

FIGURE 5 45 — Symbols and abbreviations



# ABBREVIATIONS

(Continued)

south	S	tank	Tk	university	Univ
southeast	SE	telegraph	Tel	vertical	vert
southwest	SW	telephone	Tp	village	Vil
south southeast	SSE	temporary	Temp	vineyard	V
south southwest	SSW	thorofare	Thoro	visible	vis
standard	std	tourist camp	TC	volcano	Vol
standpipe	S PIPE	tower	TR	Weather Bureau signal station	WBSIG STA
station	Sta	trail	Tr	west	W
stone(s)	St	transformer station	Transf Sta	wharf	whf
strait	Str	transmission	Transm	width	w
stream	Str	triangulation	Tri	white	W
street	St	uncovered uncovers	uncov	wreck	Wk
substitute station	Sub Sta	United States Corps of Engineers	C of E	yard	yd
submerged	subm	United States Geological Survey	USGS	yellow	Y
swamp	Sw				

# MANUSCRIPT TITLE

- ① PLANIMETRIC MANUSCRIPT 12 point
- ② T-5926 12 point
- ③ SCALE 1 20,000 8 point
- ④ SAN FRANCISCO BAY 12 point
- ⑤ ALCATRAZ ISLAND TO SAUSALITO 10 point
- ⑥ POLYCONIC PROJECTION 8 point
- ⑦ CAL STATE GRID - ZONE 3 8 point
- ⑧ HORIZONTAL DATUM N A 1927 8 point

- 1 Shoreline manuscript — Planimetric manuscript — Topographic manuscript
- 2 T number
- 3 Scale
- 4 General locality
- 5 Locality or name of quadrangle on topographic manuscript
- 6 Kind of projection
- 7 State grid including zone designation
- 8 Horizontal datum

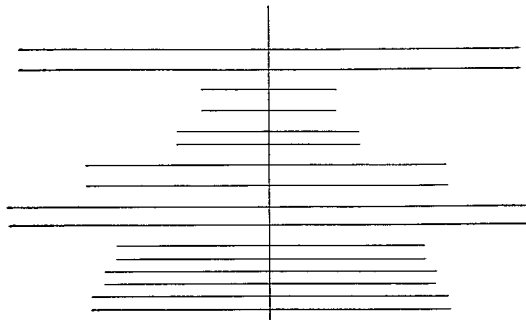

FIGURE 5 46—Symbols and abbreviations

Why  
is an  
abbrevi  
Why  
in one  
not in  
other  
US  
is work

## FREEHAND LETTERING FOR MANUSCRIPTS

### VERTICAL

6 Pt ABCDEFGHIJKLMNOPQRSTUVWXYZ Coast & Geodetic Sur  
 abcdefghijklmnopqrstuvwxyz 1234567890 & ABCDEFG

8 Pt ABCDEFGHIJKLMNOPQRSTUVWXYZ Coast &  
 abcdefghijklmnopqrstuvwxyz 1234567890 & AB

10 Pt ABCDEFGHIJKLMNOPQRSTUVWXYZ  
 abcdefghijklmnopqrstuvwxyz 1234567&

12 Pt ABCDEFGHIJKLMNOPQRSTUVWXYZ  
 abcdefghijklmnopqrstuvwxyz 8912 &

14 Pt ABCDEFGHIJKLMNOPQRSTU  
 abcdefghijklmnopqrstuvw 345 &

18 Pt. ABCDEFGHIJKLMNOPQ  
 abcdefghijklmnop 678912 &

24 Pt. ABCDEFGHIJKLM  
 abcdefghijklmnop 345&

30 Pt. NORSUVWXYZ  
 qrstuvwxyz 67890&

### INCLINED

6 Pt ABCDEFGHIJKLMNOPQRSTUVWXYZ Coast & Geodet  
 abcdefghijklmnopqrstuvwxyz 1234567890 & A B C D E F

8 Pt ABCDEFGHIJKLMNOPQRSTUVWXYZ Coast & G  
 abcdefghijklmnopqrstuvwxyz 1234567890 & ABC

10 Pt ABCDEFGHIJKLMNOPQRSTUVWXYZ  
 abcdefghijklmnopqrstuvwxyz 12345678&

12 Pt ABCDEFGHIJKLMNOPQRSTUVWXYZ  
 abcdefghijklmnopqrstuvwxyz 9123 &

14 Pt ABCDEFGHIJKLMNOPQRS  
 abcdefghijklmnopqrstuvwxy 456 &

18 Pt ABCDEFGHIJKLMNOP  
 abcdefghijklmnop 789012 &

24 Pt. ABCDEFGHIJKLM  
 abcdefghijklmno 345&

30 Pt. NORSUVWXYZ  
 qrstuvwxyz 67890&

LETTER HEIGHTS IN MILLIMETERS								
Size	6 Point	8 Point	10 Point	12 Point	14 Point	18 Point	24 Point	30 Point
Capitals	16	19	27	30	38	48	60	75
Lower Case	10	13	18	20	24	34	48	55

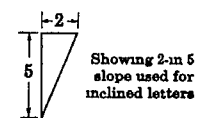
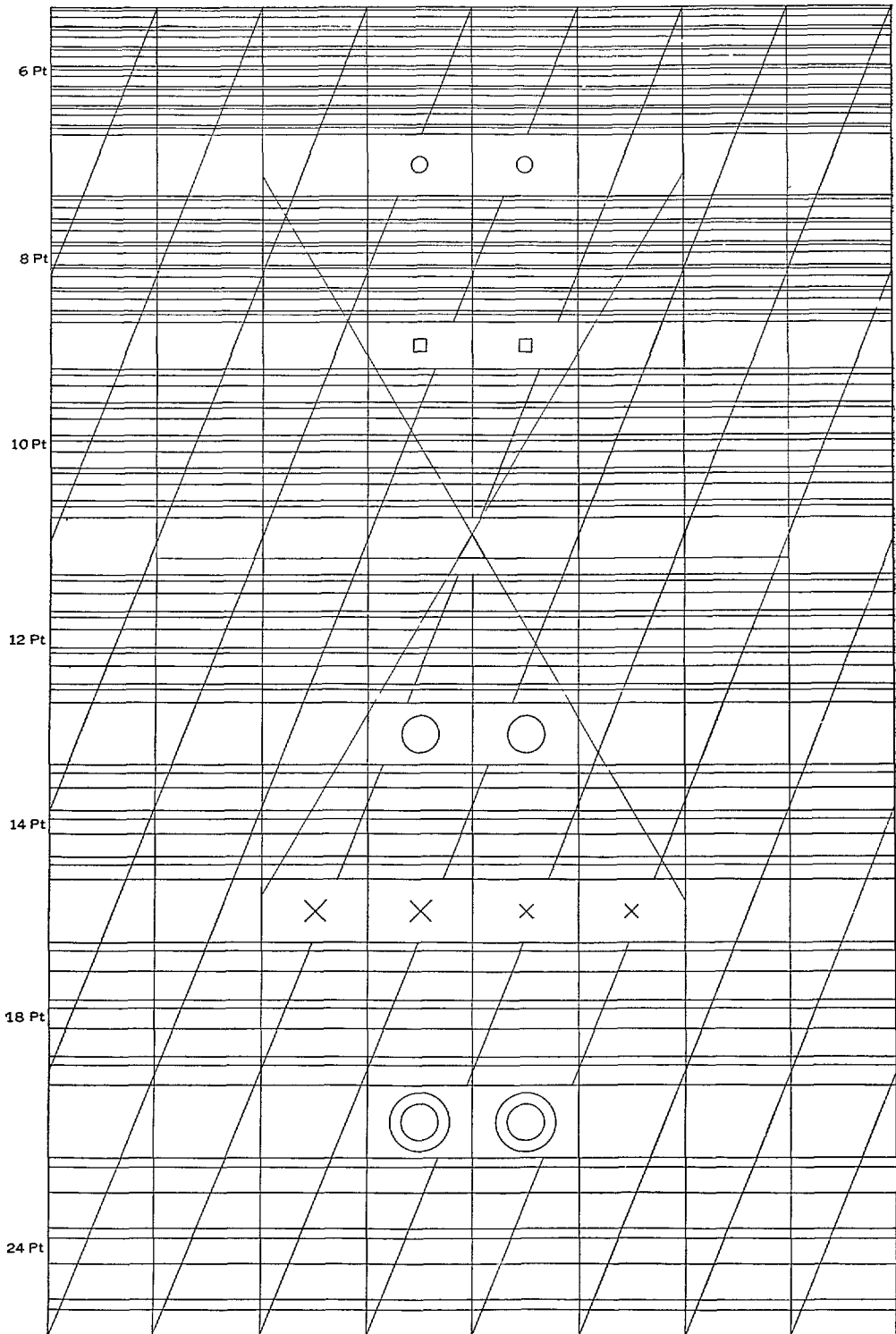

FIGURE 5 47 — Symbols and abbreviations



Copies of this guide may be ordered from the Washington Office

FIGURE 5 48 —Lettering and symbol guide

## CHAPTER 6 STEREOSCOPIC PLOTTING INSTRUMENTS

A stereoscopic plotting instrument is an optical-mechanical device for compiling topographic maps from photographs in a manner that is more direct than the usual graphic methods or the possible computational methods. Such an instrument consists essentially of a stereoscope (see 144), a floating mark (335), a device for recording the lateral motions of the mark in the form of lines on a map manuscript, and a device for setting and measuring the vertical position of the floating mark. Many different types of plotting instruments have been manufactured from time to time, but each instrument invariably contains these four parts, and the instruments differ principally in the details of construction. Some instruments are much more complicated and costly than others, and the differences in design and cost are usually related to the accuracy desired and the relative thoroughness with which the photogrammetric problem is solved. The better instruments are considered to embody a higher order of accuracy than the photographs that are used in them, and the mapping accuracy is limited by such factors as image definition, uneven aerial-camera lens distortion, instability of photographic materials, and mechanical and operational difficulties encountered in taking the photographs rather than by lack of precision of the plotting instrument.

The principal plotting instruments used by the Coast and Geodetic Survey are described in this chapter, with the requirements and specifications affecting their use. This discussion is necessarily brief and incomplete because such instruments have been used a relatively short time in the Bureau, and although they are in constant present use, their operation has not yet crystallized into a routine, instead, the methods are subject to rapid improvement and sudden change. The descriptions of these instruments are general, rather than detailed. The purpose of this chapter is to give a basic idea of the possibilities and limitations of the instruments and to describe a few of the special problems that are encountered, rather than to describe in full the mechanical details or the operational techniques.

### 61 RESUME OF CURRENT INSTRUMENTS

Stereoscopic instruments can usually be classified according to the following outline wherein are included the names of some currently used instruments

#### 1 Instruments that completely solve the photogrammetric problem

- 1 1 Perspective scanning system
  - 1 11 Optical-mechanical solution use of Porro principle
    - 1 111 Zeiss Stereoplanigraph
    - 1 112 Poivilliers Stereotopograph
  - 1 12 Optical solution
    - 1 121 Multiplex aeroprinter (Bausch & Lomb, Zeiss, Nistri, Williamson)
    - 1 122 Kelsh Plotter
- 1 2 Orthogonal scanning system space-rod mechanical solution
  - 1 21 Single step instruments
    - 1 211 Wild Autograph A5 and A6
    - 1 212 Santoni Stereocartograph
  - 1 22 Multiple step instruments
    - 1 221 Aero Service Corp (Brock & Weymoth)
    - 1 222 Reading Plotter, Coast and Geodetic Survey

#### 2 Instruments permitting a nearly complete solution

- 2 1 Photographs tiltable, simple optics, Deville-type instruments<sup>1</sup>

<sup>1</sup>Deville E. "On the use of Wheatstone Stereoscope in Photographic Surveying" *Transactions Royal Society of Canada* Vol VIII Second Series May 1902

- 211 KEK Plotter
- 212 Cook Plotter
- 213 Mahan Plotter
- 2.2 Photographs not tiltable
  - 221 Mechanical corrector
    - 2211 Nistri Stereographometer
    - 2212 Estereo-Corrector-Altimétrico, Brazil
  - 222 Graphical corrector
    - 2221 Fairchild Stereocomparagraph
    - 2222 Abrams Contour Finder
    - 2223 Zeiss Stereopantometer

“Complete solution” is used here to mean that the geometry of the photogrammetric problem is fully solved without any approximations and that an attempt is made to correct for all the known sources of error. For example, the complete solution is realized when the perspective principle, tilt, and difference in flying height of the photographs are fully recognized and accounted for, lens distortion is nullified, and distortion of photographic materials is controlled. The multiplex is the most vivid example of group 11. Film shrinkage is considered as negligible and is arrested by the use of glass diapositives, the diapositive is made in a proper ratio so that the projector lens will be at the perspective center, the lens distortion of the aerial camera is nullified in the diapositive printer, the projectors are free to be moved in all directions to accommodate for tilts and flying-height differences.

The stereoplanigraph is basically quite similar to the multiplex, full size diapositives are used, the images of the glass diapositives are projected through a duplicate of the aerial camera lens to correct for lens distortion, which is called the Porro principle, the images are projected onto separate mirrors corresponding to the multiplex tracing stand, an optical system is used to “pipe” the two views to the eyes, the mirrors are moved with reference to the diapositives by means of hand wheels, and the motions are translated mechanically to a separate drawing table called a “coordinatograph.” The Poivilliers instrument is somewhat similar, except it is claimed that the mechanism is fundamentally much more rigid and consequently of greater accuracy.

The Kelsh Plotter is almost identical to the multiplex except that full-size diapositives and only two projectors are used. The complete solution is attained in the Kelsh Plotter because the projector lens is usually at the perspective center of the diapositive. However, if the focal length of the diapositives is different from the principle distance of the projectors, the solution is exact only if the diapositives are free from tilt. The multiplex and the Kelsh Plotter employ a direct optical solution of the photographic geometry whereas in the other two instruments the solution is aided by mechanical members.

In the instruments of group 12 the Porro principle of viewing through a duplicate of the aerial camera lens is not observed, but the photographs are viewed orthogonally to a fixed plane of the instrument. For example, the line of sight determined by an image and the floating mark always passes through a fixed point (the perspective center) in the Porro system, whereas the line of sight is always perpendicular to a fixed plane in orthogonal viewing, such as where a pair of photographs is moved about beneath a fixed stereoscope. Lens distortion is then counteracted by other methods, such as by an undulated distortion plate placed over the photograph as used in the Wild instruments. Inasmuch as an optical projection is not used in this group, the intersecting optical rays are replaced by mechanical space rods to accomplish the photogrammetric solution. The single step instruments are somewhat comparable to the stereoplanigraph and stereotopo-

graph, but the American multiple step methods are radically different in that the photographs are corrected for tilt and flying-height difference by rectification in a separate photographic operation, thereby allowing the photographs to be laid flat for viewing without any further tilting provisions on the instruments. The perspective principle is observed in the Reading Plotter by the use of space rods, and in the devices of the Aero Service Corporation by graphically changing the scale of each of the contour lines by a separate step.

The better instruments of Zeiss, Wild, Porvilliers, Santoni, Nistri, and the Bausch and Lomb multiplex are designed and constructed with the idea of "bridging" between, or "extending" beyond, control points. It is not only possible to use each of the instruments for drawing contours, but also to proceed from photograph to photograph (aerotriangulation) with a limited amount of ground control. Consequently, it is sometimes advocated that some of these instruments should be used only to establish photogrammetric control points in each photograph and that the contouring and detailing should then be done on less costly devices. As a result, several of the instrument companies already named also produce a simpler instrument for detailing purposes. In the United States it has been at least suggested that the stereoplanigraph, or other equivalent instrument, be used to establish control for the multiplex, that certain multiplex instruments with proficient operators establish control for the use of other multiplex operators in detailing, that the multiplex establish control for use with the stereocomparagraph or other device, and that the Kelsh Plotter be used to establish sufficient control points for use on the KEK Plotter.

The instruments of Group 2 have been purposely simplified as compared to those of Group 1, in order to obtain instruments of practicable but limited use at a greatly reduced cost. The photogrammetric problem is not exactly solved but the resulting approximations are within acceptable limits for many purposes and the instruments can often be used where the cost of the more complex instruments would not be warranted. The use of these instruments is usually accompanied by a greater cost of ground control and a longer time for compilation than is required in the use of the more complex instruments. No attempt is made to "bridge", but sufficient control is supplied in each model by ground surveying, by radial plotting, or by a more precise stereoscopic instrument. In group 21 the photographs are not necessarily viewed from the proper perspective distance, but in many instances the error is very small and is corrected by fitting the compilation to a radial plot or other form of horizontal control. The vertical scale of the stereoscopic model is not necessarily the same as the horizontal scale, but this does not constitute any additional inconvenience—even the multiplex operator uses a conversion table to reduce the elevation readings from a metric model scale to conventional ground dimensions. No correction is usually made for lens distortion except by contouring part of the model at a time, but narrow-angle or normal-angle photographs are usually employed wherein the lens distortion is very small. Although tilting the photographs does not have the same effect when the photographs are viewed from an incorrect perspective distance, nevertheless little difficulty is encountered because the tilts are usually small, and again only a part of a model need be "leveled" at a time. It should also be noted that in each of these instruments the floating mark is not in a "real" image of the stereoscopic model due to the simple optical system, but the floating mark is in the "virtual" or imaginary model which is subject to the deformations described in 333. A redeeming feature of many of the simpler plotting instruments is that operations are restricted to a relatively small range of elevation as compared to the flying height of the aerial camera, limiting the magnitude of the errors that might become excessively large if a great height range were involved.

No provisions are made for tilting the photographs in the instruments in group 22. However the Brazilian instrument has a mechanical device for correcting the floating mark separation for the effects of tilt, paper shrinkage, and scale, the Nistri instrument affords a perspective correction to the map for relief displacement, and correction graphs are used with the instruments in 222 to show the changes of the corrections in the floating mark separation for all sources. The instruments in 222 are the simplest of all, in each of them the floating marks are in contact with the photographs, whence the deformation of the mental stereoscopic model do not influence the settings of the marks. In all except the Nistri device, the compiled map is equivalent to a tracing of one of the photographs (the one in which the floating mark is rigid) and thus the compilation is tilted in the same manner as the photograph, and the contour lines are subject to relief displacements in the same amounts as the images through which the lines pass. The compilation is a tilted perspective. The effect on the final map, however, is usually not very great because the tilts are normally small and because the compilation is usually altered later to fit horizontal control points that are obtained by radial plotting, or otherwise. In the Nistri instrument, the resulting map would be a correct orthogonal compilation if the photographs were not tilted and if lens distortion and material shrinkages were negligible. The Reading plotter is somewhat comparable to the instruments in 222, except that the position of the tracing point is continuously corrected for relief displacement and rectified metal-mounted photographs are used.

## 62 THE NINE-LENS METHOD

The Coast and Geodetic Survey uses specially developed photogrammetric mapping instruments and methods based on the nine-lens camera, in addition to using single-lens photographs. Four instruments are used in making topographic maps with the nine-lens system—namely, (1) the nine-lens aerial camera to take the photographs, (2) the transforming printer to produce a single photographic print from the aerial camera negative, (3) a rectifying camera to remove the effects of the unavoidable tilt of the aerial camera in flight, and the effects of small unavoidable errors in flying height, and (4) a stereoscopic plotting instrument (the Reading Plotter) to compile topographic map manuscripts from the transformed and rectified photographs.

The Bureau uses the special photogrammetric system to map coastal areas for which the use of current single-lens photographs has not offered a satisfactory solution. For example, three special characteristics of aerial photographs that are of economic importance in coastal mapping in such distant and undeveloped areas as Alaska are (1) each photograph should include a very large area so as to reduce the amount of ground control, especially where there are off-lying islands or irregular shoreline and where a map of a relatively narrow strip of land is all that is required, (2) the photograph should be of a sufficiently large scale and clarity so that shoreline details can be accurately identified, and (3) the photographs should be usable for drawing contour lines accurately. The Bureau also uses single-lens aerial cameras and methods because the special nine-lens equipment is fully utilized, and frequently sufficient ground control is available so that the single-lens methods are adequate. Because of their great coverage, the nine-lens photographs have been in such popular demand that, although it has been possible to take the desired number of photographs with the aerial camera, it has not been possible to produce as many prints with the transforming printer as were requested. Consequently, the camera has been arbitrarily used mostly in Alaska where its greatest advantage is gained.

The general procedure for the compilation of topographic maps by the nine-lens method is discussed briefly before the instruments themselves are described. The camera is flown

in a B-17 type aircraft through a co-operative arrangement with the U S Coast Guard. The pilots and crew are Coast Guard personnel. An officer of the Coast and Geodetic Survey acts as navigator during photographic missions and actually pilots the airplane while photographs are being taken, and a photographer of the Coast and Geodetic Survey operates the camera. The film is sent to the Washington Office for development, although a piece of film at the end of each roll, or in each part of a roll, is developed in the field to check the functioning of the camera. (See 223)

Each negative is measured in the laboratory to determine the amount of film shrinkage, and the transforming printer is adjusted to correct for it, after which a print is produced. At least once a year calibration photographs are taken of a nearly-flat test area near McClure, Ohio, where some 80 targets of known position and elevation have been established, and based on these a master metal templet is prepared for use in operating the transforming printer. Photographs to be used with the Reading Plotter are printed on metal-mounted paper to prevent paper distortion, and those to be used for graphic compilation are printed on a good grade of low-shrink paper. A radial plot is then assembled and adjusted, using transparent vinylite hand templates and the metal-mounted photographs. Positions are thus determined for objects of known elevation. If shoreline shows on the photographs, the positions of numerous sea-level objects are determined.

Rectification is performed with reference to the radial templates on which the radial-plotted positions of objects occur as needle-holes. The radial templet is converted into a rectification templet by displacing each point radially outward from the center according to its elevation. The settings of the rectifying camera are adjusted in a prescribed manner so that the images of the photographic points are projected onto their respective templet positions. The photograph is then exposed onto a second sheet of metal-mounted photographic paper. The rectified print is negative in tone and the images are reversed in relative position. This negative print can be used in the plotting instrument but not without some difficulty, preferably the print is recopied with the rectifier in which all the adjustments are set for duplication, producing the customary type of positive photographic print.

Two recopied metal-mounted overlapping prints are then used on the Reading Plotters. The photographs are properly oriented for stereoscopic vision, details are traced using the floating mark, and contour lines are likewise drawn by setting the floating mark at a pre-determined elevation and then tracing along the side of a slope so that the mark always seems to be in contact with the ground of the stereoscopic model. The map that is compiled with the plotter is then transferred to the radial plot map manuscript to complete the topographic manuscript.

## 621 THE NINE LENS AERIAL CAMERA

The nine-lens aerial camera of the Coast and Geodetic Survey is described in 223 and is illustrated in figure 26. A schematic diagram of the camera is shown in figure 27 and a diagram of the negative produced by the camera is shown in figure 28.

## 622 THE TRANSFORMING PRINTER

The transforming printer (figure 61) is the instrument with which the nine-lens aerial negative, consisting of one vertical and eight oblique exposures on one piece of film 23 inches square, is projected onto a single piece of photographic paper to make a composite photo-



graph 35 inches square The resulting transformed photograph is equivalent geometrically to a photograph taken with a single-lens camera whose angular field of view is equal to that of all nine lenses of the nine-lens camera ( $130^\circ$  by  $130^\circ$ ) Pains-taking efforts are made to reduce discrepancies from the theoretical equivalent single-lens photograph to less than 0.2 mm It should be understood that the nine-lens photograph is *not* geometrically the same as a mosaic wherein each photograph has a different point of view, nor the same as an assembly of oblique photographs that have been printed on separate pieces of paper and then fastened together

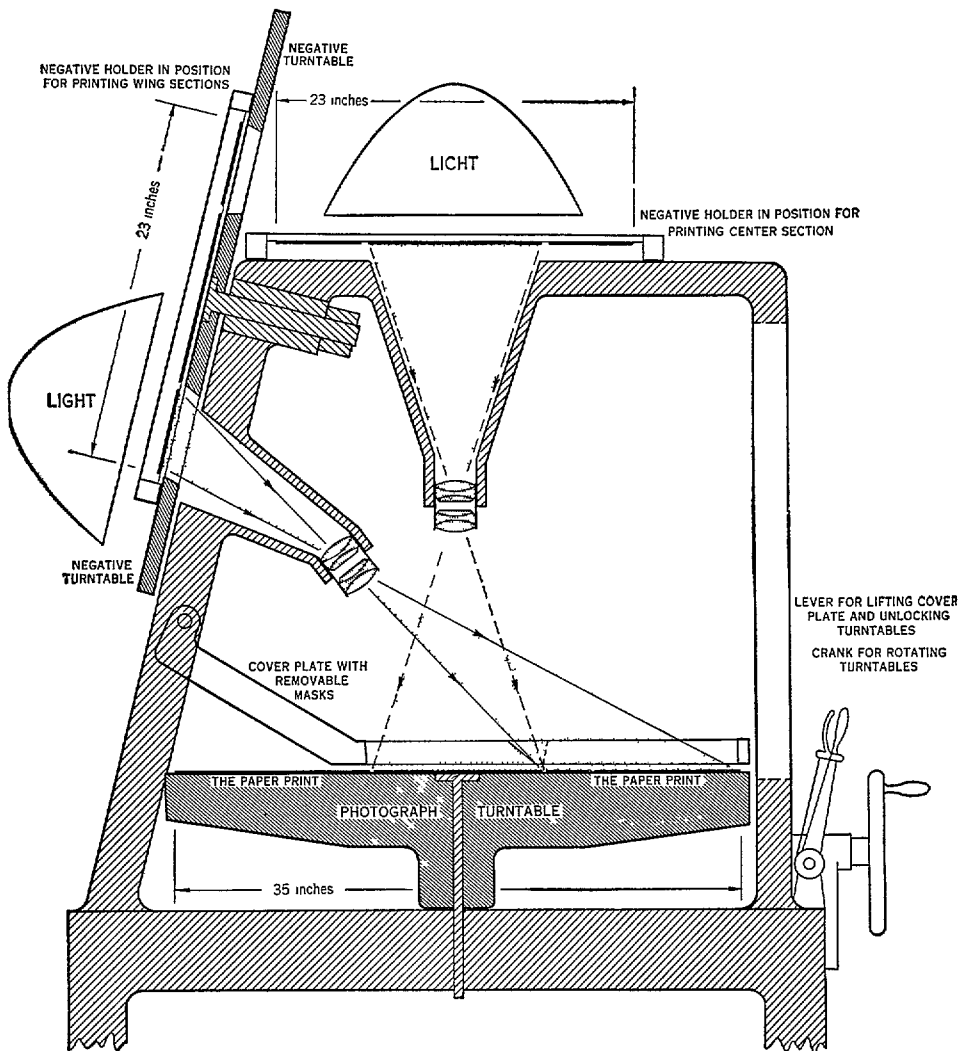

FIGURE 61—Diagram of the transforming printer

The transforming printer is a combination of an enlarging camera set at a 1:1 ratio for the center print, and a rectifying camera for the oblique sections The nine-lens negative is supported in a holder which is placed in each of two positions on the top of the printer

for printing the center section, and on the oblique negative turntable for printing the oblique sections. A partition is built around the printer so that the negative turntable and the top of the printer are on the daylight side, whereas the photograph turntable is on the darkroom side. The oblique sections are exposed one at a time, after one exposure the turntables (geared together so as to rotate synchronously and lock into position at designated intervals) are turned  $45^\circ$  (or  $90^\circ$ ) to make the next exposure. The printer is equipped with two Goerz Dagor lenses whose focal lengths are about  $8\frac{1}{4}$  inches—the same focal length as the lenses of the nine-lens camera.

Three differently shaped masks, with openings corresponding to the shapes of the corner, side, and center sections of the transformed photograph, are successively placed over the photographic paper so as to expose only the required area for each section without fogging adjacent areas of the paper. Metal-mounted photographic paper is used on the horizontal turntable if the prints are to be used on the Reading plotter, low shrink paper is used for most radial plotting for planimetric mapping, and double-weight, matte, kodabromide paper is used for making prints for field use. A vacuum pump holds the photographic paper flat on the turntable and also holds the negative tightly against the glass face of the film holder.

Several adjustments are provided on the printer to correct for film shrinkage, for the calibration constants of the aerial camera, and for the constants of the printer itself. The magnitude of each of the adjustments is indicated on a dial gage with an accuracy of 0.01 mm. The two lenses can be moved a small amount to change the relative sizes of the projected photograph, which compensates for the fact that the focal lengths of the nine lenses of the aerial camera are not exactly equal but vary through a range of about 1.5 mm. The negative turntable can be tipped slightly in two directions and translated up and down the inclined plane, and the two turntables can be rotated slightly from their locked positions. (An adjustment for translating the negative turntable in a transverse direction is included in the design of a new transforming printer.) Two operators are employed with the instrument—one to make the photographic exposure on the darkroom side and one to set the adjustments on the daylight side. Some of the corrections do not comply with the theoretical principles of rectification (36). However, the adjustments are so small that the desired image movements are obtained without affecting image definition. The lenses are usually operated at a relatively small aperture.

A negative sight is used in conjunction with the transforming printer to center the aerial film negative in the holder and to measure the shrinkage of the film. The sight consists principally of an optical device by which one can see simultaneously the principal point and the four corner collimating marks of the film, as well as small metric grids that indicate the amount and direction of shrinkage along the two diagonals of the film. The film is oriented in the holder so as to distribute the film distortion as symmetrically as possible, and the average shrinkage value is used to determine the lens setting for printing the center section.

The adjustments of the printer are made so as to cause the 41 fiducial marks to fall in their respective required positions. The negative in its holder is placed in position on the negative turntable and projected onto a master metal templet on the photograph turntable. The adjustments are then altered until all the fiducial marks of a given section fall into their correct places, and the settings are recorded on a card. The selection of the proper adjustments and the amount and direction of each are a matter of experience and judgment of the operator on the darkroom side. After all eight oblique sections have been corrected, the master templet is replaced with photographic paper and the series of

exposures is made with the proper settings as recorded. A complete adjustment to the master templet is made for every photograph that is to be used on the Reading Plotter, but for other uses a complete adjustment is made only as often as is required to keep the discrepancies at moderately small magnitudes. Residual errors in radial directions are corrected for radial plotting as described in **4213**.

The operator varies the exposure time from section to section and also shades certain parts within a section so as to produce an even-toned photograph. This 'dodging' procedure is subject to the judgment of the operator, but the exposure patterns are similar for most nine-lens photographs. A record is made of the shading diagram on a card that shows each of the nine sections with pencil lines to indicate the different areas of exposure and numbers to indicate the number of seconds of exposure in each area.

An ordinary paper print (field print) is usually produced before a print is made for radial plotting or for the Reading Plotter. The field print is not only needed for field use but it also serves as a test print both for the transformer adjustments and for the shading diagrams. If a discrepancy is evident on the field print, the operator changes the record cards accordingly before making more prints.

The master metal templet that shows the correct positions of the 41 fiducial marks is a result of a study of nine-lens photographs taken of a nearly-flat special test area near McClure, Ohio, where there are over 80 ground targets whose positions and elevations have been determined (see **2231**). A topographic map that has a contour interval of 2 feet with levels along all the roads was also made of the test area by field methods. A satisfactorily transformed print is made of the area by repeated trials with comparisons to the correct positions of the 80 images, and with stereoscopic examinations to discover deformations from a flat model. The positions of the fiducial marks in the final print are then considered as being correct, and all subsequent photographs are made to conform to these positions of the fiducial marks until the aerial camera is again adjusted, as when a mirror is replaced.

The fiducial marks on a nine-lens photograph do not necessarily form a perfectly symmetrical pattern, although it was intended that they should be as symmetrical as practicable. It is sufficient that the marks exist in each section of the negative in the same place, and that they always occur in the same relative positions in all photographs.

The lines that show the divisions of a nine-lens photograph are caused by the masks, and *these lines are in no way related to the accuracy of the photograph*. Sometimes the lines are white, indicating that the narrow strip was covered with a mask when both of the adjacent sections were printed and thus remained unexposed, and sometimes they are black, indicating that they were exposed twice—once while making each of the adjacent sections. Consequently, these mask lines are of no importance photogrammetrically.

### 623 THE RECTIFYING CAMERA

The rectifying camera (figure 62) is constructed on two levels with the lens axis vertical. The focal length of the lens is 23 inches. The instrument is large enough to accommodate the nine-lens photographs but it can be used with any type of aerial photograph except that it is limited mechanically to near-vertical photographs. It is designed to operate with the system of rectification that refers all settings to the line of centers (the principal point line). The planes of the negative, the lens, and the positive (easel) are each normally horizontal, and they can be inclined about each of two perpendicular hori-

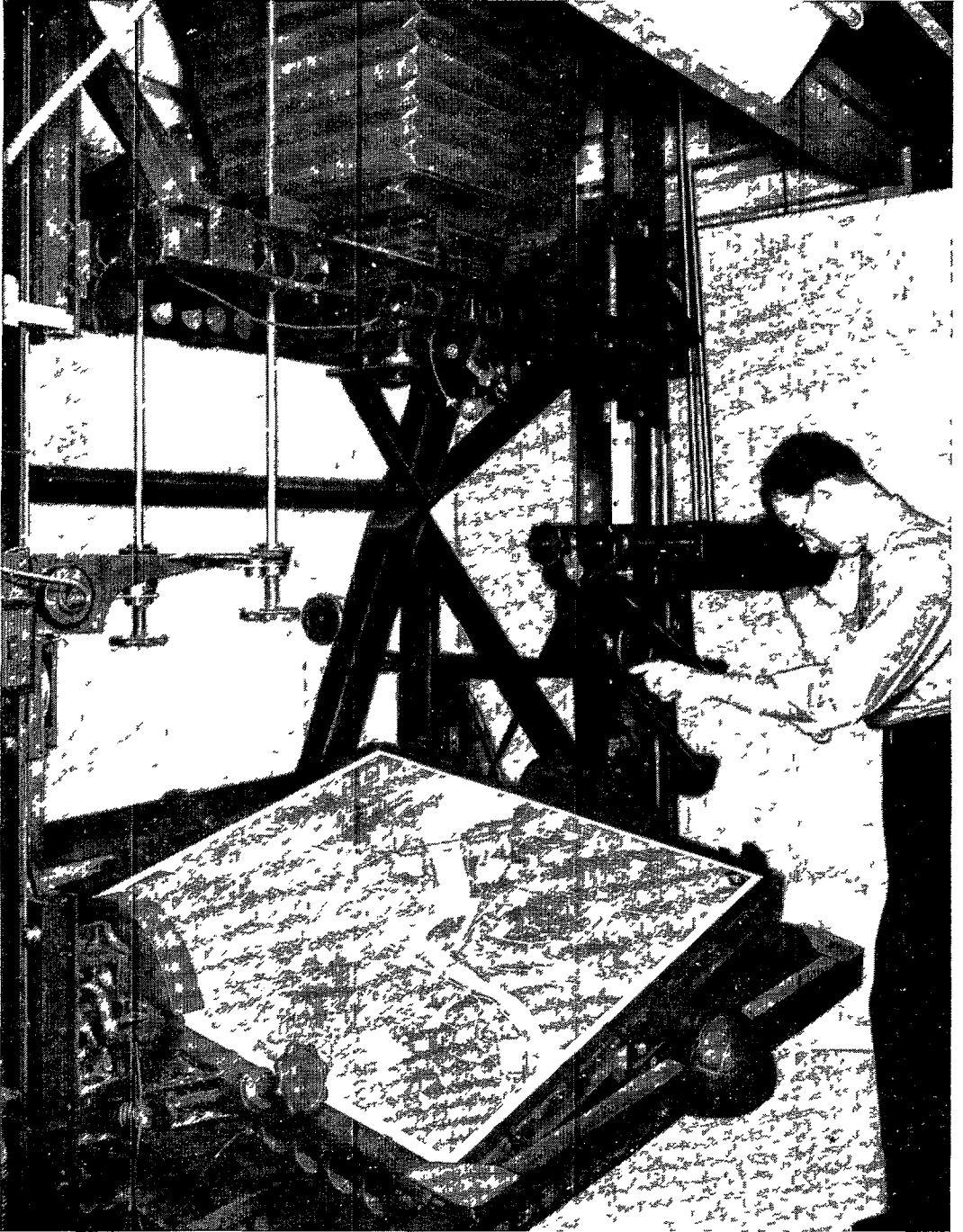

FIGURE 62—The rectifying camera

zontal axes similar to the  $x$ -tilt and  $y$ -tilt of the multiplex. Graduated circles and verniers are provided for reading each of the six angular settings to the nearest minute, and linear scales with optical sights are provided for reading the positions of the lens and the easel to the nearest 0.1 mm based on zero for a 1:1 ratio. The negative, or upper plane that holds the transformed print in position by vacuum, is illuminated with reflected light for use with the Reading Plotter because an opaque metal-mounted transformed print is used for rectification. The resulting rectified photograph is thus negative in tone and relative position, from which a positive print is made in the rectifier at a 1:1 ratio and with all the adjustments set for zero tilt. The instrument is also equipped with a focal plane glass plate and transmitted illumination for use with film. The rectifier is automatic focus but when the photographs are tilted a correction must be applied to the optical distance of the easel. All the settings can be made from the lower level, which is a photographic darkroom, as well as from the upper level, which is on the daylight side. The rectifier can be used either with computed data, or with a rectification templet, for which the settings are coordinated by means of empirical rules and graphs.

The theory and the general procedure for the operation of the rectifier, including the preparation of the rectification templet, the method of coordinating the settings, and the method of locating the nadir point of the rectified photograph from the record of the settings, are discussed in 367 and 3671.

#### 624 THE READING PLOTTERS

The Reading Plotters (figures 63 and 66) are instruments for compiling topographic maps stereoscopically from aerial photographs of equal flying height that have been rectified and whose dimensions can be as much as 36 inches square. The two instruments are very similar in basic design but they do not look very much alike. The instruments were designed and manufactured at the same time but Plotter A was the first one to be assembled and adjusted. Plotter A is described first and then the differences between the two instruments are discussed in 6242.

Any pair of rectified aerial photographs or enlargements therefrom can be used satisfactorily with the plotters although they were designed primarily for use with the nine-lens photographs. Hence the plotters are said to be independent of the focal length of the aerial camera. Photographs taken with a metrogon lens, however, probably could not be used without first correcting the photographs for lens distortion. The map scale produced by the instruments is normally the same as the datum scale of the photographs and is usually controlled entirely by a photographic scale change during rectification. It is also possible to compile correctly at a scale somewhat smaller than that of the photographs. Complete theoretical correction is accomplished mechanically for the reduction of all planimetry to the datum scale for any elevation up to half the flying height. Elevation readings are shown on an indicator graduated in equally spaced divisions of one-thousandth of the original flying height of the aerial camera, and tenths of divisions can be estimated. The relation of the indicated elevations to the original flying height is not changed by any photographic enlargement or reduction of the photographs.

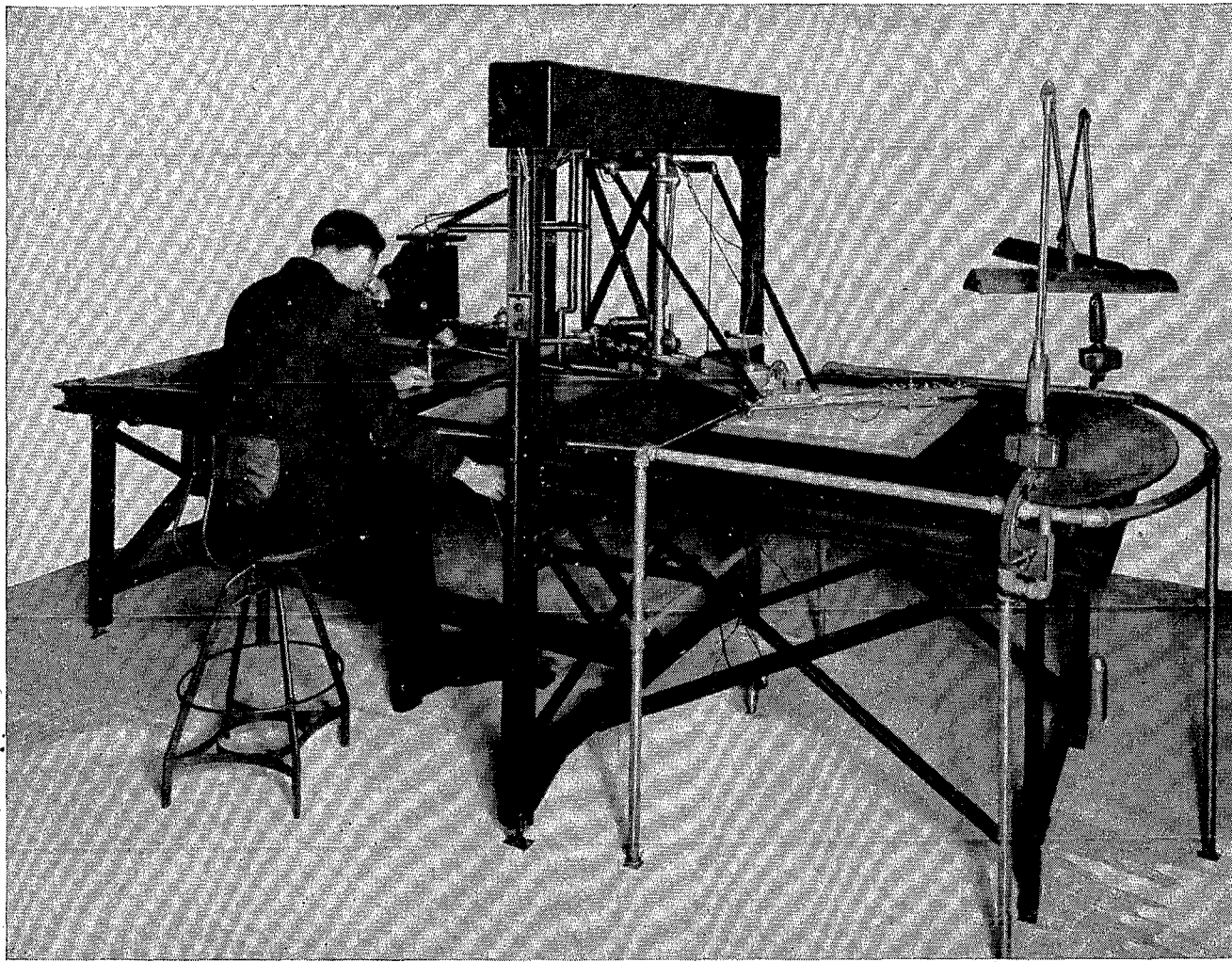

FIGURE 6.3.—Reading Plotter, Model A.

6241. *Description of Reading Plotter—Model A*

The stereoscope of Plotter *A* is suspended so that it can be moved freely above the surfaces of the photographs. The center line of the stereoscope is kept parallel to the azimuth line of the photographs by a parallel motion device similar to that illustrated in figure 1.15. The objectives of the stereoscope are about 40 inches apart and, for reasons of mechanical design, the eyepieces are not in the center of the stereoscope. The stereoscope is moved by means of a convenient handle which is held and moved like a pencil. The operator views the photographs from a seated position in daylight, seeing an area about 2 inches in diameter at a magnification of two times. Bright artificial illumination is applied to the area being viewed by means of lamps attached to the stereoscope. The instrument can be operated from either side by rotating the eyepieces 180°. The floating marks are fixed small round black dots on reticles mounted in the optical trains of the stereoscope. The operator moves the stereoscope horizontally to make the floating mark trace the images of the stereoscopic model, and the motion drives the pencil point of a pantograph correspondingly to draw the map. The floating mark is kept in contact vertically with the images of the stereoscopic model with the action of a foot wheel. The eyepieces of the stereoscope are adjustable for focus, and interocular distance, and also for convergence for the comfort of the operator.

Photographs are clamped to tables of the instrument with the nadir points at the centers of rotation, and the tables swung with slow motion screws to achieve relative orientation and clamped in position. The position of the nadir point of a photograph is determined from a graph (figure 3.55) and is based on the settings of the rectifying camera that are required to make the photograph fit the rectification templet. A base length is set in the instrument with a handwheel by which the left photograph (figure 6.3) is moved to the right or left parallel to the azimuth line until the floating mark seems to rest on an image of known elevation when the elevation is set on the indicator. The base length is set just once and clamped for a given pair of photographs. The operation of the footwheel, which causes the floating mark to rise or fall, moves the left photograph to the right or left in the same direction as the base length setting. The right photograph can be moved a limited amount in the transverse direction to remove any residual  $y$ -parallax, the magnitude of which is registered on a counter.

A rotation of the footwheel changes the length of the elevation member of a mechanical elevation-parallax computer. This change in length is transferred to the necessary parts of the plotter by steel wires and bands and is used to change (1) the reading of the elevation indicator, (2) the lengths of the arms of the pantograph mechanism to alter the plotting scale, and (3) the position of the plotting table to correspond to the change in the dimensions of the pantograph. At the same time, a change in the length of the parallax member of the mechanical computer is generated which moves the left photograph so as to change the apparent vertical position of the floating mark.

The operation of the parallax generator is fundamental. Triangle  $ABC$  (figure 6.4) and the line  $DE$  represent a mechanical linkage that is located beneath the left photograph of the plotter. A fixed right angle is at  $C$ , and a fixed distance  $BC$  represents the actual flying height  $H$  of the photographs. The dimension  $CD$  is set by the base-length handwheel and the dimension represents the photograph base  $b$ . The line  $DE$  is maintained perpendicular to  $DC$ . The dimension  $DE$ , representing the elevation  $h$  of the object, is the elevation member that is driven by the rotation of the footwheel which moves point  $E$  vertically downward from  $D$ . A change in the length of  $DE$  causes a rotation of the line  $BEA$  about the fixed point  $B$  thus causing the point  $A$  to move along the line  $CD$  extended, and generating a change in the length of the parallax member  $DA$  which is

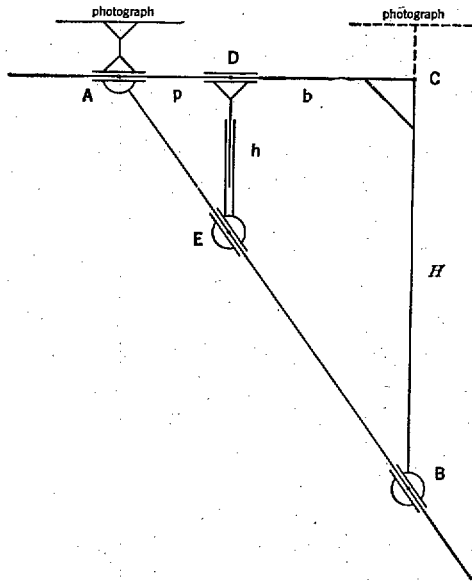

FIGURE 6.4.—Elevation-parallax generator mechanism.

represented by the letter  $p$ . Because of the similar right triangles in the figure, the ratios of the lengths of corresponding sides can be equated algebraically:

$$\frac{h}{p} = \frac{H}{b + p}$$

It is to be noted that this is the same relation that was developed in 3262 in which  $h$  and  $p$  are differences in elevation and parallax, respectively.

The photographic image of an elevated area has a larger scale than sea level shoreline because the former is closer to the camera, and as verified by the algebraic equation 3222C,  $S = f/(H-h)$ . Thus the scale  $S$  becomes larger as the elevation  $h$  becomes greater with given values of flying height  $H$  and focal length  $f$ . The sea-level or datum scale can be expressed as  $S_0 = f/H$  inasmuch as  $h$  is zero, and the scale of an area of elevation  $h$  is correspondingly  $S_1 = f/(H-h)$ . If all images are to be plotted at the common datum or sea-level scale, then all images not at sea level should be reduced in scale by the ratio

$$r = \frac{S_0}{S_1} = \frac{f/H}{f/(H-h)} = (H-h)/H \tag{6241A}$$

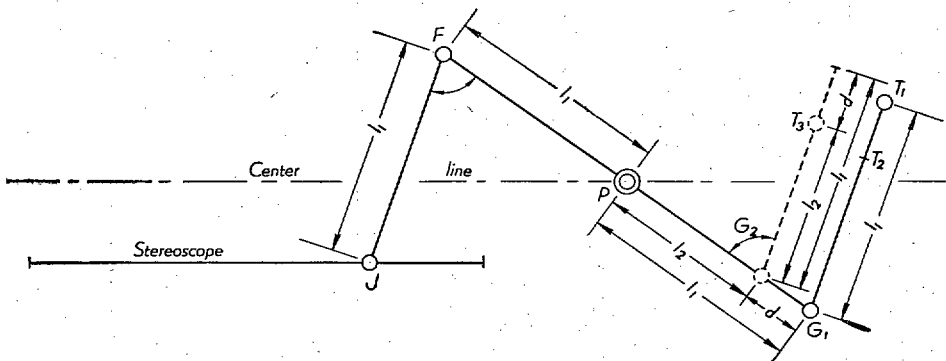

FIGURE 6.5.—The stereoscope-pantograph mechanism.



Figure 6 5 is a schematic diagram of the stereoscope-pantograph mechanism in which the stereoscope is mounted at  $J$ , the tracing pencil at  $T_1$ , a fixed pivot is at  $P$ , the lengths  $l_1$  of the arms of the stereoscope are fixed dimensions, and the lengths of the arms of the pantograph are  $l_1$  at 1:1 ratio for sea level images and  $l_2$  for images of elevated objects. It is obvious without proof that if both arms of the pantograph are shorter than those of the stereoscope, then the amount of movement of the pencil point at  $T_3$  is less than the movement of the point  $J$  of the stereoscope in a fixed proportion in any direction of movement. Thus map detail can be drawn at a smaller scale with the pantograph than is traced by the floating index mark of the stereoscope. Moreover, the ratio of reduction produced by the pantograph is related to the dimensions of the arms, or  $r = l_2/l_1$ . For accurate map compilation, this ratio should be the same as that expressed in 6241A, or

$$\frac{l_2}{l_1} = \frac{H - h}{H}$$

if  $d = l_1 - l_2$ , or  $l_2 = l_1 - d$ , by substitution,

$$\frac{l_1 - d}{l_1} = \frac{H - h}{H} \quad (6241B)$$

By the rules of algebra for ratios and proportions, 6241B can be expressed as

$$\frac{d}{l_1} = \frac{h}{H}$$

which shows that  $d$  is directly proportional to  $h$ . But the value of  $h$ , or  $DE$ , relative to  $H$ , or  $BC$ , (figure 6 4) is generated by the mechanical computer when the operation adjusts the footwheel to make the floating mark rest vertically on an image of the three-dimensional stereoscopic model. The dimension  $d$  is proportional to the magnitude of  $DE$  and the increment is translated with pulleys of proper diameters and wires from the computer to the arms of the stereoscope. Thus the scale change is correct and is continuously changed by the operator as he moves the floating mark from image to image always keeping the mark in contact vertically with each image. The vertical position of the floating mark is shown in 326 and 335 to be definitely related to the elevation of the object on the ground.

The component of the dimension  $T_1T_3$  that is parallel to the center line of the plotter (the common azimuth line of the photographs) is the distance through which the map sheet is moved so that the pencil point will remain at the same point on the map while the floating mark is made to trace the image of a vertical object such as the edge of a tall building. The component is also proportional to the height of the object above the ground, and consequently proportional to the  $h$  or  $DE$  dimension of the computer mechanism whence the component is also transferred by means of wires and pulleys. The proof of the proportionality of  $T_1T_3$  to  $h$  is not given. The relation is quite evident, however, in view of the previous proof, together with the similar triangles formed in figure 6 5, and the fact that as the floating mark is made to trace the image of a vertical object the point  $J$  is moved radially with respect to the pivot  $P$  in accordance with the relief displacement of the image on the right photograph. The motion of the pencil point at  $T_3$  along the outer arm of the pantograph, and the motion of  $G_2$  along the inner arm are such that the same angles are always maintained at  $G_1$ ,  $G_2$  and  $J$ . The mechanical arrangement of the pulleys, wires, and gears to change the pantograph scale is somewhat involved, if not ingenious, and it functions very well.

The plotter is designed and used principally by a single operator without a helper. The pencil point is raised and lowered by a solenoid operated through a switch located conveniently for the operator.

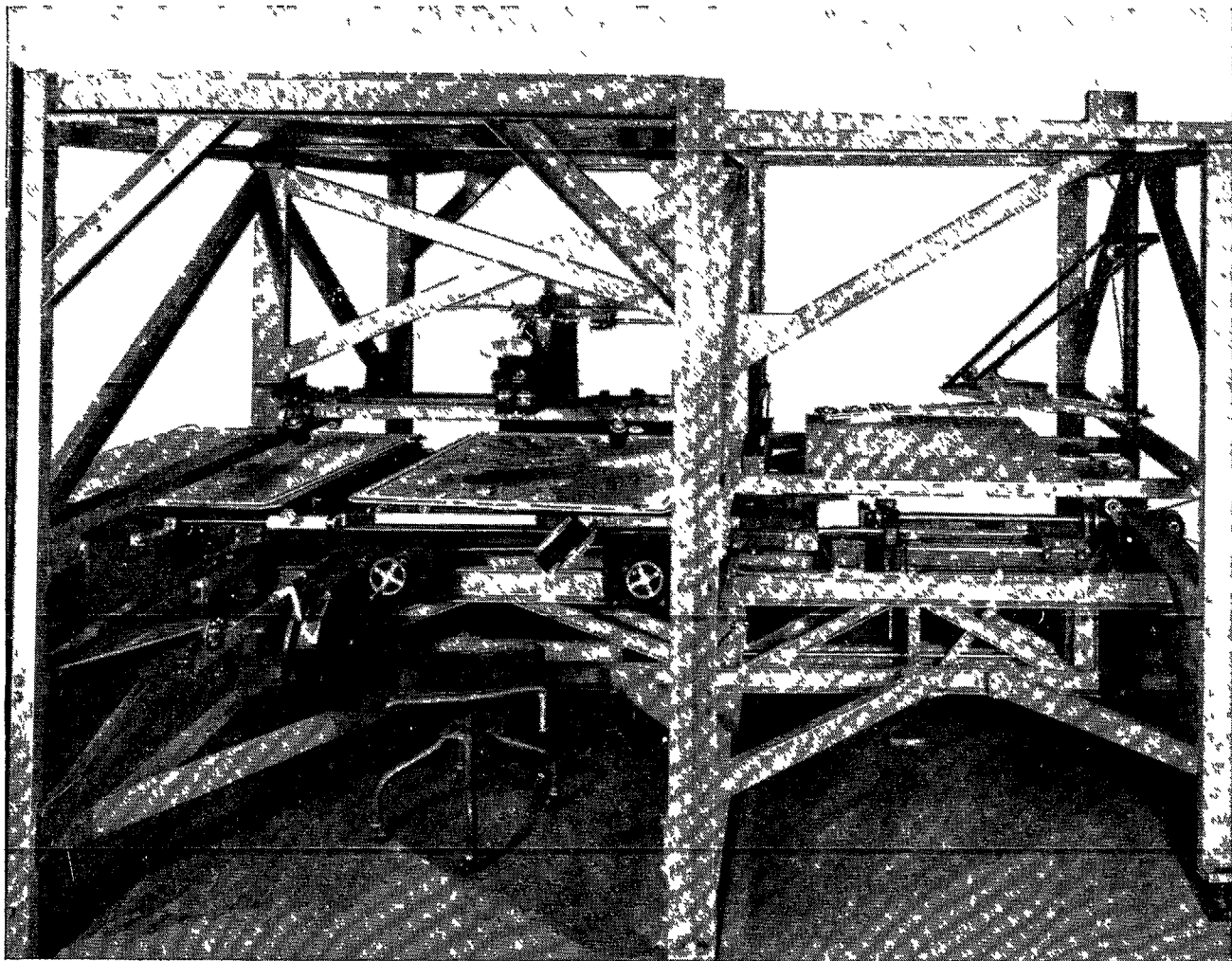

FIGURE 66—Reading Plotter Model B

*6242 Differences in the Two Models*

Plotter *B* (figure 66) is similar in basic design to plotter *A* but differs in operation. In plotter *B* the stereoscope is fixed and the photographs are moved about beneath the stereoscope with handwheels, whereas in *A* the photographs are stationary and the stereoscope is moved about with a pencil-like motion. Plotter *B* is sometimes referred to as the wheel-driven model because, like many European plotting instruments, the floating mark is seemingly moved longitudinally with a crank by the left hand and transversely with a crank by the right hand. The metal framework of plotter *B* is necessarily very rigid to minimize any deflections that might occur when the heavy photograph-table assembly is moved from one part of the instrument to another to view different parts of the photographs. The great weight of the table is quite necessary because (1) the photograph supports need to be rigid relative to each other for desired accuracy, (2) one photograph table must be movable longitudinally for elevation parallax, (3) the other photograph must be movable in the transverse direction for *y*-parallax, (4) both tables need to be moved as a unit on a carriage along a longitudinal track, (5) both tables and the carriage must be movable as a unit on a second carriage along a transverse track, and (6) the parallax-changing mechanism actuated through a stationary footwheel must be connected to the triply-moving right photograph regardless of its position or motion with respect to the stereoscope. Otherwise the functional parts of the two plotters are identical.

Due to the short time that plotter *B* has been in operation, it is not possible to compare the merits of the two instruments justly.

*6243 Control for the Reading Plotters*

The Reading plotters have functioned very satisfactorily in the two principal types of mapping for which they have been used, namely, for compiling 20-foot contours in areas near the eastern seaboard of the United States where the elevations range from sea level to about 300 feet, and 100- and 200-foot contours along the southern shore of the Alaskan Peninsula where the elevations range from sea level to 3500 feet. In both areas the flying heights were about 14,000 feet and the compilation scales were 1/20,000.

In the first area, levels were run along nearly every road to determine elevations at approximate half-mile intervals. It has been found desirable to space the level lines so that the total area is subdivided into small areas of 1½ square miles or less that have level lines on at least three sides. In developed areas it is generally practicable to place most of the required vertical control along roads. The horizontal control consisted of the existing triangulation stations which averaged about one station per photograph. The overlap was 60% in both directions. Tests indicated that the map complied with the National Standards of Map Accuracy.

On the Alaska Peninsula the vertical control consisted of ocean shoreline and the elevations of inland mountain peaks spaced 2 to 4 miles apart. The elevations were determined trigonometrically by observations from points along shore and from inland triangulation stations. The area was covered with one or two strips of photographs and usually extended only about 3 miles inland from the heads of the bays. The horizontal control consisted of identified triangulation stations spaced 4 to 8 miles apart. The side lap was 60% whereas the forward lap was frequently 80%. Inland elevations are quite necessary lest the rectification be performed erroneously from the shoreline control which might all lie on one side of a photograph, thus yielding very large errors for inland heights. Ordinarily, much less vertical control is required for mapping an island where tidal shoreline is visible on two sides of the photographs.

The accuracy of mapping with the Reading Plotters is limited by the accuracy of the nine-lens photographs and the spacing of vertical control, rather than by the accuracy of the plotting instruments, which function with a higher degree of precision than is ordinarily needed. If the discrepancies resulting from the transforming step were negligible, there would be little difficulty in accurately compiling 10-foot contours instead of 20 from 1 20,000 scale photographs and with even less vertical control. Insofar as the plotting instrument itself is concerned operators can read elevation differences of 10 foot using 1 20,000 scale photographs. The errors in transformation are evidently due largely to the differential film shrinkage that occurs between the time when the film is exposed and when it is printed. Residual errors of  $\pm 0.3$  mm (scarcely noticeable without the use of a magnifying measuring stereoscope) in the positions of some of the details sometimes occur on the transformed photographs. These errors when combined with similar errors of the other photograph of the stereoscopic pair can produce elevation discrepancies of as much as 40 feet, which can be discovered and thoroughly corrected if sufficient vertical control is available. Efforts are constantly being made to remove all obvious sources of error, to improve the precision in plotting, and to simplify the operational procedures. Meanwhile, sufficient ground control is obtained to insure correction of residual errors in the transformed photographs.

The present specifications for ground control for topographic mapping with 1 20,000 scale nine-lens photographs in Alaska may be summarized as follows:

No part of the area to be mapped shall be more than 3 miles from either tidal shoreline or a point of known elevation (vertical control point).

No part of the coastline shall be more than 4 miles and no part of the interior area to be mapped shall be more than 8 miles from a horizontal control station.

#### 6244 *Radial Plotting for the Reading Plotters*

Slightly different procedures than stated in 42 shall be used in the preparation of radial plots for topographic map compilation with the Reading Plotters. These instructions supplement and supersede in part the instructions contained in 42 for radial plots to be used *for contouring with the Reading Plotters*.

(a) The principal reasons for the additional instructions arise from the fact that both the radial templates and the metal-mounted nine-lens office photographs that are used in the preparation of the radial plots are used again in rectification and compilation. Greater accuracy in radial plotting is desired than is usually required ( $\pm 0.3$  mm) for making planimetric maps, because 0.3 mm can cause elevation discrepancies of from 15 to 50 feet in the use of the plotters. A plethora of accurately located photogrammetric points are used in rectification. Inasmuch as the photographs are copied during rectification and the copies are used on the plotter, no unnecessary marks or lines shall be left on the photographs to confuse the operator in stereoscopic compilation. As an aid in adjusting the settings of the rectifier, it is desirable that the circles on the photographs and templates be of a definite size and color so that they can be identified in the dim photographic illumination of the rectifying camera, where the images themselves cannot be seen clearly. Consequently the circles shall be correctly placed on the photographs during radial plotting so that they will not have to be changed.

(b) Metal-mounted photographs shall be used for all radial plotting for the Reading Plotters. Every care shall be exercised in the laboratory to produce transformed prints in which any discrepancies are as small as possible. A trial visual fitting of the fiducial

marks of each of the eight sections of the photograph shall be made to determine the transformer settings before a print is exposed (This is usually done only periodically for planimetric mapping and graphic compilation) For stereoscopic plotting work, the special vacuum negative film holder that presses the film tightly against the glass shall be used because pressure plates alone sometimes allow small airpockets to form between the film and the glass which cause significant discrepancies Thus, a great deal of care must be taken to produce a transformed print of exceptionally high quality

(c) Every step of photograph preparation for radial plotting shall be performed with the best stereoscope available Every point that is identified and transferred, and every azimuth line should be applied with a stereoscope—no point should be pricked without the use of the stereoscope Nearly all attempts to prepare photographs without using a stereoscope have resulted in random discrepancies up to 0.5 mm which are sometimes unnoticed in planimetric mapping but which are glaringly evident when the photographs are viewed with the Reading Plotter Hence, a stereoscope must be used in every phase of photograph preparation The K & E prismatic stereoscope (1443) is considered to be the best instrument for this work because of its magnification, bright image and large size

(d) Azimuth lines shall be applied with azimuth liners used with a stereoscope as described in 4113b Azimuth liners are strips of heavy vinylite 4 by 18 inches in size with a fine straight line scribed in the center of one side from end to end and with fine holes at intervals along the line Azimuth liners are used with the scribed line in contact with the photograph The azimuth line is transferred to a photograph by pricking through the holes in the azimuth liner and then connecting the pricked points with a fine line Azimuth liners tend to warp into curved lines with age and varying atmospheric conditions and hence must be checked frequently for straightness by laying one on the other and reversing

(e) The following points (some of which are in addition to those specified in 4115 and 4116) shall be located by the radial plot and their positions shall be shown on the base sheets, templates, and manuscripts for use in stereoscopic mapping

- 1 All vertical control points whose geographic positions are not available from geodetic computations

- 2 All photo (topo) and photo-hydro points

- 3 A series of special pass points for use in rectification shall be selected along the shore and so interspersed between the triangulation, photo (topo), and photo-hydro points that a point will be located at mean high water elevation about every 3 to 4 inches along all tidewater shorelines In creeks and sloughs less than 200 meters wide, this spacing may be considered as along the axis of the creek These points are at equal elevation (mean high water) and of known horizontal position (determined by radial plot or by ground surveying methods) The points are necessary both in the rectification of the photographs and in contouring Any point of detail that can be identified in the office can be selected for such a pass point as long as it is at mean high water as closely as can be judged by stereoscopic inspection These points shall be designated by the letter "R" on the office photographs and on the base sheets

- 4 In addition to the pass points in 3 above, other pass points shall be selected and located as necessary to make the radial plot and to provide a density of located points such that no place on the manuscript will be more than 3 or 4 inches from a point of known position (located by radial plot or by ground surveying)

(f) In the preparation of the photographs, all selected image points shall be pricked with a fine needle, preferably with a pricking device in which the needle point is approximately at right angles to the handle. All symbols, names, and legends on office photographs shall be in washable ink, preferably in black, white, or red for contrast—yellow ink is not satisfactory because it does not photograph well against the dark background of a photograph. The ruling pens and drop-bow pens should be sharpened so that they draw a reasonable fine line without cutting the photograph emulsion. This is important because it is sometimes necessary to wash off some of the symbols prior to rectification, and the emulsion might also peel off if it has been cut during inking. Azimuth lines shall not be drawn full length on the photographs, but shall be limited to a length of about 1 inch at the conjugate centers only. Furthermore, only very short radial lines for use in the preparation of the templates shall be drawn on the photographs. These lines should generally be no longer than about one-half inch. Only those notes that are essential shall be written on the photographs. Each ground control or photogrammetric point (photo-hydro, photo (topo), vertical control point, or pass point selected for rectification) shall be identified by name or number on one, and only one, photograph.

(g) Contrary to the instructions of chapter 4, ground control points and all radial plot points shall be indicated on the photographs with circles 4 mm in diameter. Photograph centers shall be shown with concentric circles 4 and 6 mm in diameter. (Note that the circles on the radial templates and base sheets as stated in (j) below are of different sizes.)

(h) Vinylite shall be used for the radial line templates. The method of correcting the radial lines for errors in transformation as described in 4242 and 4243 shall be used wherever such discrepancies exist. Craftint No 111 red ink (512) is extremely satisfactory for drawing radial lines on vinylite templates. A very fine, sharp, dense line can be drawn easily with this ink, and the line can be wiped off the template with Craftint No 111 solvent.

(i) The general procedures stated in 425 for assembling and adjusting the radial plot shall be observed except that even greater precautions should be taken if possible to obtain the very best results. A preliminary plot (4252) is considered as being extremely worthwhile. It is usually necessary to re-lay a radial plot two or three times before the best possible adjustment has been obtained. Any time spent in re-laying a plot is more than compensated for by the saving of the time in rectification and instrument compiling in the Washington Office. After the adjustment has been perfected, the positions of each intersected point shall be marked on all the templates and on the base sheets by *drilling* (not punching) a vertical hole through the complete assembly as instructed in the last two paragraphs of 4254.

After disassembly of the radial plot, the top templates shall be compared with the base sheets to see that the pin holes were drilled vertically and where a discrepancy occurs, the base sheet positions shall be made to agree with the top templates.

(j) The base sheets, templates, manuscripts, radial plot report, and all other data shall be sent to the Washington Office for use in compilation with the Reading Plotter. The points located by the radial plot shall be marked on the base sheets in *washable blue* ink according to the following instructions:

- 1 Photograph centers shall be shown by concentric circles 3 and 5 mm in diameter
- 2 All located points, control points, and photogrammetric points shall be symbolized with circles 3 mm in diameter

3 The names and/or identifying numbers of all ground control and photogrammetric points shall be shown

4 The elevation of each vertical control station shall be shown on the base sheet, but not on the templates

5 Notes may be made freely on the base sheets—difficulty in fitting to control points in the radial plot, other information that is not contained in the radial plot report, and that may be helpful to the Washington Office should be noted on the base sheets

6 Vinylite is relatively stable with regard to humidity changes, but must not be exposed to radical *temperature* changes. Thus, the base sheets and templates should not be exposed to direct sunlight nor placed close to radiators

(k) The notes and symbols on the radial templet shall be made as follows

1 The photograph number of each templet shall be shown in black ink in the corner corresponding to its location on the photograph

2 The center of a templet shall be shown with concentric red circles 3 and 5 mm in diameter. (These circles are of a different size than on the photograph (par (g) above) so that in optical projection in rectification, the pairs of circles just fit inside each other, and any eccentricity is thus immediately obvious.)

3 All ground control and photogrammetric points shall be shown with red circles 3 mm in diameter. The radial plot points shall not be identified by name or number

4 The photograph numbers of conjugate centers shall be shown in red

(l) Symbols and notes on the manuscript shall be made in accordance with the instructions given in 4254 except that the position of each vertical control point shall be indicated and symbolized on the manuscript but the elevation of the vertical control point shall be omitted. The elevations will be added in the Washington Office after contouring

## 63 THE MULTIPLEX PROJECTOR

The Coast and Geodetic Survey uses Bausch and Lomb wide-angle multiplex projector equipment (figure 67). The instruments are used in conjunction with the Fairchild cartographic camera "O" and the F-51 camera "C" (see 222)

### 631 DESCRIPTION OF MULTIPLEX EQUIPMENT

The multiplex method of mapping consists essentially of reprojecting two overlapping photographs in a darkened room so that the image rays intersect in space above a flat table top to form a visible stereoscopic model that can be measured in height and traced orthogonally onto a map sheet on the flat table top by use of a tracing stand. Lantern slide reductions (diapositives) of the aerial negatives are used in the projectors. Stereoscopic vision is accomplished by the anaglyphic principle wherein complimentary red and green filters are placed in alternate projectors, and the operator wears spectacles that contain one red lens and one green lens so that he sees only the photograph from one projector with one eye, and only the photograph from the other projector with the other eye.

The diapositives are made from the aerial film with a special reduction printer which is part of the multiplex equipment. Two important functions are accomplished with the printer. The aerial negative is photographed at an exact ratio so that the principal distance of the diapositive is equal to the corresponding fixed principal distance of the multiplex projectors (30 mm), and the distortion characteristics of the aerial camera lens are corrected by opposite distortion characteristics of the printer lens. By this method, the image light rays that are emitted by a projector have the same directions relative to each other and to the lens axis, as did the object light rays when they entered the aerial camera at the instant

of exposure. The head of the reduction printer, i.e., the part containing the lens and controlling the scale of the diapositives, must be especially built for the type and focal length of aerial-camera lens with which it is to be used. The ratio of the reduction printer can be changed a small amount by means of two knurled rings to accommodate for small differences in focal lengths of aerial-camera lenses of the same type, and for uniform shrinkage in the aerial negatives. The reduction printer of this Bureau is for use with 6-inch metregon lenses.

A projector consists essentially of a light source with condenser and cooling system, a supporting stage for the diapositive, a precise lens system, and one color filter. Each

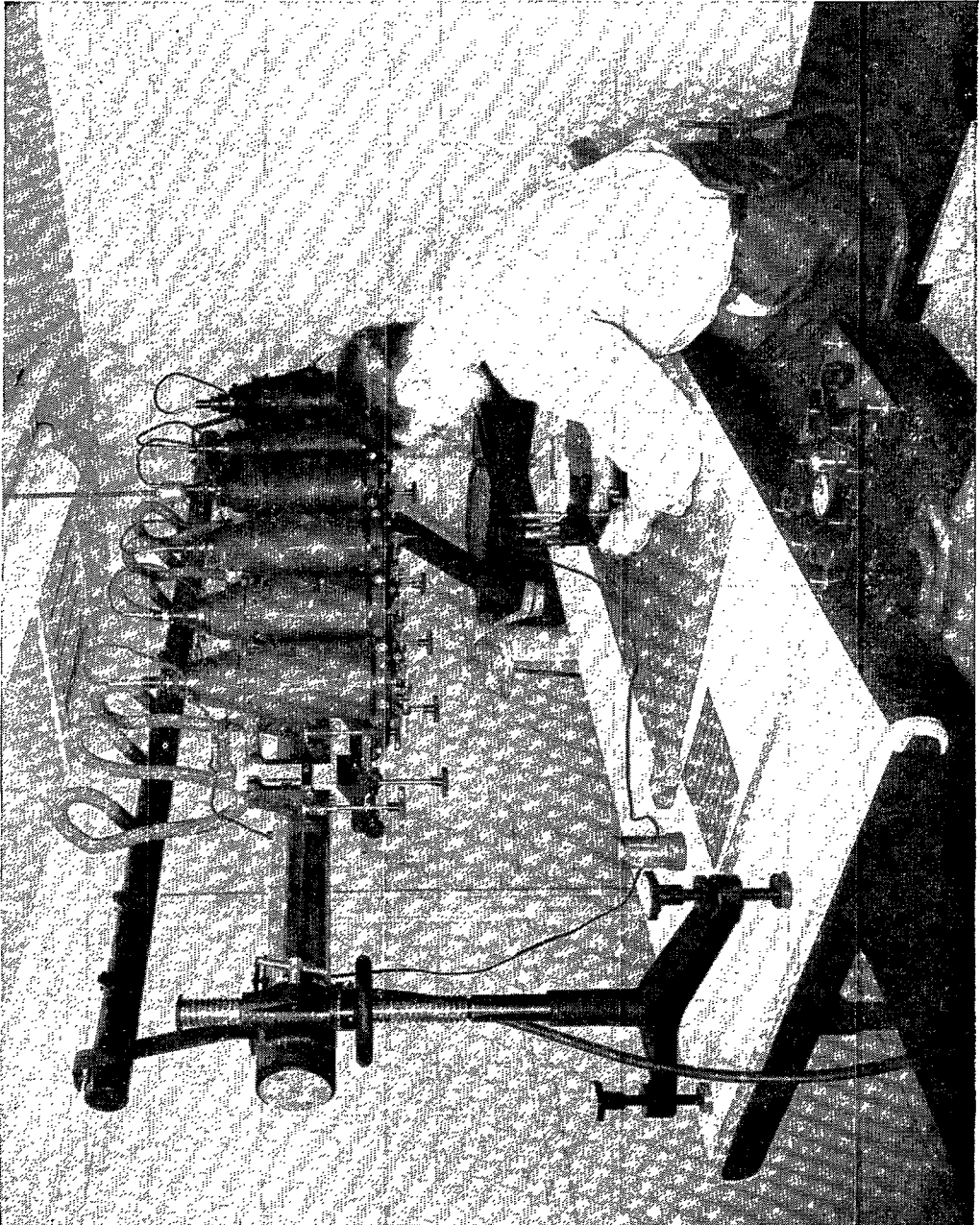

FIGURE 6.7.—Multiplex apparatus.



projector is mounted so that it can be moved linearly in the three dimensions of space, i.e., in  $x$ ,  $y$ , and  $z$  directions and can be rotated about each of these three coordinate axes. Thus, it is possible to orient two projectors relative to each other so that they have the same relative positions and orientations that the aerial camera had at the two instants of exposure.

The adjustable mounts of the projectors are supported on a bar which is itself adjustable for absolute orientation as explained in a subsequent paragraph.

Two projectors are oriented with respect to each other (relative orientation) by a methodical technique.<sup>2</sup> The details of the technique are not presented here, but the operation consists of causing all common image rays to intersect by properly adjusting the three angular rotations and two of the linear motions of at least one of the projectors. The bases of the technique are that two common image rays intersect if there is no  $y$ -parallax (3263), and the removal of  $y$ -parallax in certain critical parts of the stereoscopic model assures its removal in all of the model. If there is no  $v$ -parallax in any part of the model, then the projectors have the same orientation relative to each other as the aerial camera had at the instant of exposure. This is a logical phenomenon in view of the facts that (a) An object on the ground (a bush, for example) reflected a ray of light in a straight line through the camera lens to the film when the shutter was opened, (b) After the camera had been transported a certain distance another ray from the same object repeated the procedure from a different angle, (c) The diapositive printer and the multiplex projectors are designed to duplicate the relative directions of the light rays, (d) Hence if the pair of image rays (of the bush) are made to intersect in a point in the model, and if all the other pairs of image rays conform in the same manner (optical resection in three dimensions—see 3534A), it is reasonable to assume not only that the projectors are oriented as the cameras were, but also that the multiplex stereoscopic model is an undistorted relief model of the original terrain with the projectors corresponding to the aerial camera in its two positions.

After two projectors have been relatively oriented, a third projector can be oriented relative to the second one with the usual technique and without disturbing either of the first two projectors. The scale of the second model (formed by the second and third projectors) can be adjusted so that it is equal to that of the first model inasmuch as points in the common overlap of the two models must have the same positions and elevations. In the same way a fourth, fifth, etc., projector can be added.

The initial relative orientation of two or more projectors produces a stereoscopic model whose horizontal datum plane is not parallel to the table top and whose scale is not known. The procedure of *horizontalizing* and *scaling* the model is called *absolute orientation*. Horizontalizing the model is done by changing the inclination of the two or more projectors as a unit with adjusting screws at the ends of the supporting bar, and at the four feet of the frame that supports the bar. The adjustments are made until elevations in various parts of the model are correct. Scaling a model is done by changing the relative spacing of the projectors along the bar until the horizontal distance between two horizontal control points in the model is equal to the corresponding distance between the plotted positions of the control points on the map manuscript.

If there is horizontal control in the first and last models, the entire strip of projectors in a line of flight can be scaled, and the procedure is called *horizontal bridging*. If there is no control after the first model, the procedure is referred to as an *extension of horizontal control*. Horizontal bridging for coastal mapping is ordinarily limited to 7

projectors, but occasionally 10 projectors are used with a special double-length bar and table. Ordinarily, no *vertical control* bridging is attempted, a vertical control point is required in each of the four corners of every model.

The multiplex tracing stand consists essentially of (a) a white platen which is the image screen for producing and measuring the stereoscopic model (the image that is projected on the table top is of no significance and is not used in any way), (b) a pinhole in the center of the platen, beneath which is an electric lamp, shows as a luminous dot, or floating mark, that seems to be a part of the stereoscopic model, (c) an accurate screw adjustment by which the platen can be raised or lowered, (d) an accurate scale to indicate the height setting of the platen or floating dot within 0.01 mm, (e) a pencil point vertically beneath the pinhole for tracing the details of the model orthogonally onto the map sheet, and (f) three slick agate bearing pad supports on the tracing stand, which produce a minimum of friction when the stand is slid about horizontally on the map sheet. (The multiplex tracing stand is also used with the Cook and Kelsh plotting instruments.)

When the floating dot is at the intersection of two common image rays coming from the two projectors simultaneously, the dot seems to be in contact with the ground of the stereoscopic model at that point. Hence, to place the dot on the ground at any point is equivalent to placing the dot at the intersection of two image rays. The horizontal position of any point is then indicated by the position of the pencil point on the map, and the elevation is indicated by the vertical scale of the tracing stand. The operator can trace a road on the map by sliding the floating dot along the road in the model, raising or lowering the dot as necessary, as he traces, to keep the dot in contact vertically with the image of the road. The elevation of any point in the model can be measured in millimeters and converted to a conventional unit by applying a constant scale factor obtained from conversion tables. A contour line can be drawn by setting and locking the platen at a desired elevation, and then moving the tracing stand so that the floating dot always seems to be in contact with the ground. If when tracing a contour line along the side of a hill, the dot is not in contact with ground, it seems either to *float* above, or to *dig* into, the ground.

The multiplex operator ordinarily works with only two projectors at a time, all the other projector lamps being turned off, because a stereoscopic model is formed with but two photographs inasmuch as one has but two eyes. An operator occasionally has three projectors turned on at a time when he ties two models together, but he shades out one of the projectors while viewing the model formed by the other two.

An experienced multiplex operator usually needs about 0.7 mm vertical separation for successive contours in the stereoscopic model so as to draw the contour lines with standard map accuracy. However, he can read differences in elevation between well-defined objects in the model within 0.15 mm and can adjust the model to vertical control stations within 0.15 mm. The vertical distance from the projectors to the platen is fixed at about 360 mm for best image definition. Inasmuch as this distance represents the flying height of the aerial camera, the vertical separation places a practical limit on the flying height for a required contour interval. If  $H$  is flying height and  $c$  is contour interval, it is evident that

$$\frac{H}{360} = \frac{c}{0.7}$$

Thus, for a contour interval of 20 feet, the flying height is nearly 10,300 feet. The ratio of flying height to contour interval is

$$\frac{360}{0.7} = 514$$

or  $H = 514 c$ , or the flying height is 514 times the contour interval. To change this contouring factor is equivalent to adopting a different value for the vertical contour separation in the model in place of 0.7 mm. The character of terrain features of a given area might enable an operator to work satisfactorily within a smaller vertical separation, and sometimes more experienced operators do not require as much as 0.7 mm. In fact, many multiplex operations are based on a factor of 750, whence the operators must work within less than 0.5 mm vertical separation for a contour interval.

### 632 MANUSCRIPT PREPARATION

The scale of the multiplex model is fixed within close limits by the flying height inasmuch as the projection distance of the projectors is 360 mm for sharp focus. However, because of the small aperture of the projector lenses, images are formed through an extreme vertical range of from 270 mm to 450 mm. This is called *depth of focus* and provides for differences in elevation in parts of the model and permits a small adjustment to the compilation scale. Since 360 mm is 1.181 feet, the compilation scale  $S$  is

$$S = \frac{1.181}{H} \text{ or } 1.085 H$$

Thus, if the flying height is 10,000 feet, the map scale is 1:8500, if the flying height is 12,000 feet, the map scale is 1:10,000, nearly. Thus, the multiplex compilation scale is actually determined by the contour interval which determines the flying height. The compilation scale (1:8500 to 1:10,000 for 20-foot contours) is much larger than the map publication scale and much larger than is usually convenient for the map manuscript. Consequently, the preparation of the map manuscript from the multiplex work sheets is somewhat of a problem and the method used varies with conditions.

In this Bureau, multiplex compilation is done on transparent vinylite sheeting for two reasons, to minimize sheet distortion, and to permit the transfer of some of the shoreline and alongshore details directly from field inspection photographs to the work sheet. Field inspection is done on ratio prints at the same scale as the multiplex compilation, to facilitate the direct transfer of photo-hydro stations, rocks awash, and other small details, which might not be seen in the multiplex model, directly from the field photographs to the work sheets.

The limits of a multiplex work sheet are determined by the flight lines of the aerial photographs and may or may not conform to the desired latitude and longitude limits of the map manuscript, since the flight lines must often be laid out to parallel the coastline, rather than in accordance with the map limits. Consequently, there are from two to perhaps eight work sheets in a  $7\frac{1}{2}$  minute quadrangle. A separate work sheet is ordinarily used with each strip of six to ten photographs, although it is sometimes practicable to use a work sheet covering one-half of a quadrangle, that is,  $3\frac{3}{4}$  minutes of latitude by  $7\frac{1}{2}$  minutes of longitude, in which case two or more adjacent strips of photographs are compiled on one sheet.

#### 6321 1:20,000 Scale Manuscripts

Where the scale of the multiplex work sheets is reduced considerably, to the manuscripts, as for example, where the work sheets are at a scale of 1:10,000 or larger and the manuscripts are at a scale of 1:20,000, one of the following methods is used.

(a) A film negative of each work sheet is made at the reduced scale of 1:20,000. These film negatives are then attached to a manuscript projection ruled on transparent vinylite sheeting, the negatives being adjusted exactly to the manuscript projection. Positive photographic prints of this 1:20,000 scale composite negative are then made for use in field edit and one on vinylite is made for the *map manuscript*. After field edit, the

1 20,000 scale *manuscript* is corrected and the following copies of it are prepared by photography blue-line boards for use in smooth drafting and a lithographic print on cloth-mounted paper for registry in the Bureau archives The multiplex work sheets are completed for all manuscript details prior to preparation of the composite negative, with the exception of some of the marginal lettering and notes which can be conveniently added to the manuscript at the time the field-edit corrections are applied The multiplex work sheets are drawn in pencil—only those details are inked that need to be clarified and those that are faint and might not photograph clearly After a map has been reviewed and registered in the Bureau archives, the work sheets are discarded, but the manuscript is retained in a semi-permanent file

(b) The manuscript mentioned in (a) is printed in one color only and consequently does not conform to the specifications of 54 In some cases a one-color manuscript may not be acceptable and the project instructions may specify that all manuscript details, including marginal notes, be inked in color on the work sheets, which become semi-permanent records A preliminary composite negative of the work sheets is made as described in (a), with somewhat less care being used in fitting the negative sections to the projection, and from this field-edit prints are made After field edit, the work sheets are corrected and a second composite negative at scale 1 20,000 is made as described in (a) from which the blue-line boards are made for smooth drafting and a lithographic print on cloth-mounted paper for registry in the Bureau archives

#### 6322 1 10,000 Scale Manuscripts

In some instances, particularly where the coastline is intricate and involved with many off-lying rocks, topographic manuscripts at 1 10,000 scale may be required for Bureau purposes In this case each 7½ minute quadrangle manuscript consists of two sheets, each 3¾ minutes in latitude by 7½ minutes in longitude The manuscripts are prepared as follows

(a) If the multiplex work sheets cannot be in the form of one-half quadrangle units because of the arrangement of flight lines, details from each work sheet are *traced* in ink onto the manuscript projection The work sheets are left in pencil except insofar as inking is necessary for clarity and to avoid loss of details during multiplex compilation Each of the large-scale manuscript sheets is reproduced photographically and copies are printed at 1 20,000 or 1 10,000 scale for use in field edit After field edit the manuscripts are corrected and 1 20,000 scale negatives are made from which blue-line boards are made for use in smooth drafting, 1 10,000 scale lithograph copies are also made for Bureau use and registry in the Bureau archives

(b) In some instances only shoreline and alongshore features are required at the 1 10,000 scale, in which case a 1 20,000 scale quadrangle manuscript is also prepared from a composite negative as stated in 6321a This saves the time required to trace the interior details from the work sheet to the 1 10,000 scale manuscripts but results in three manuscripts for each quadrangle one quadrangle manuscript at scale 1 20,000 and two half quadrangle sheets at scale 1 10,000 which latter show only the alongshore details

(c) In some instances the arrangement of flight lines permits multiplex compilation directly on the 1 10,000 scale manuscript sheets and separate work sheets are not required, thus eliminating the tracing step mentioned in 6322 (a)

#### 64 THE STEREOPLANIGRAPH

The Bureau uses one Zeiss stereoplanigraph (figure 68) for topographic mapping The instrument has been adapted for use with photographs taken with 6-inch metronom

cameras. The stereoplanigraph has been satisfactorily used for various special, as well as routine, applications. Its extreme versatility and accuracy make it applicable in a large variety of circumstances.

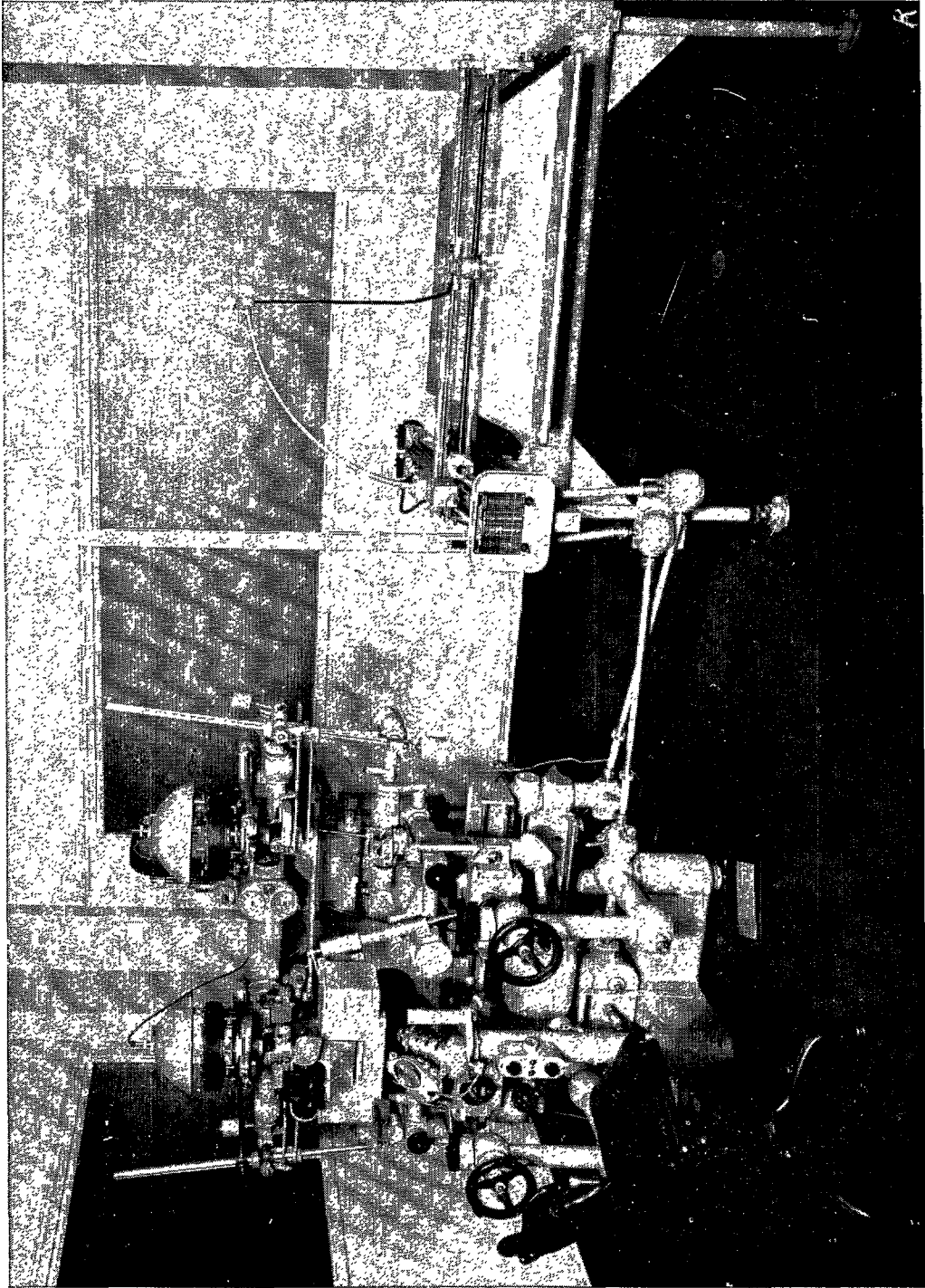

FIGURE 6.8.—Stereoplanigraph.

The stereoplanigraph is surprisingly similar to the multiplex in its basic operation despite the great difference in appearance. The diapositives are full size, being contact prints (or 1:1 projections) from the aerial film onto 3/16-inch glass plates. The instrument has only two projectors. The diapositives are mounted at prescribed distances from the lenses, the distances being slightly variable for different metrogon lenses used. The diapositives are illuminated with simple small electric lamps that are automatically moved about over the local areas being viewed. The projector lenses are duplicates of the aerial camera lens. Consequently, the emergent image rays are projected in the same relative directions that the object rays had on entering the aerial camera lens. The emergent image rays are parallel rays that do not come to focus, but an auxiliary lens is mounted below the projector lens so that the image rays are brought to sharp focus at the point of viewing. The focal distance of the auxiliary lens is changed automatically by a mechanism that changes the separation of the elements.

Instead of a platen as used in the multiplex, the stereoplanigraph has for each of its projectors a steel mirror with a black dot at its center and the auxiliary lens operates so that the dot is always at the sharp-focus position of the projected image. The mirror reflects the light rays from one projector into a complicated optical system through which the eye sees the photograph and the dot as though they were superposed. A second mirror and optical system function similarly for the other projector and the other eye. Thus, stereoscopic vision is created in a fully lighted room as though one were to look at the two diapositives with a simple stereoscope having a magnification of 5 diameters. The images are very bright and clear because of the full-size diapositives and because a mirror is used instead of the diffusion screen (top) of the platen that is used in the multiplex.

The two projectors are a fixed distance apart. The scale of the model is fixed by the projection distance, which can be varied over a comparatively large range. The floating dot is caused to seem to rise or fall with a rotation of a footwheel that raises and lowers the pair of projectors as a unit relative to the mirrors and the dots. The dot is caused to seem to move toward and away from the operator with a handwheel on the right that moves the pair of projectors as a unit. The dot is caused to move to the right and left with a left handwheel that moves the mirrors and dots as a unit.

The horizontal motion of the dot relative to the model is transmitted by gears, couplings, and screws from the handwheels to a pencil point on a plotting table which is called a coordinatograph. At one place in the train of gears is a special gear box where different sizes of gears can be inserted to change the ratio of movement of the pencil point relative to the movement of the floating dot in the model. Thus, any desired scale of drawing can be obtained by a proper combination of projection distance and choice of gears from a ratio of 1:10 to 5:1 relative to the scale of the photographs.

The relative orientation of two diapositives in the projectors is performed by a technique exactly analogous to the multiplex technique. The model is horizontalized by using common inclinations of the two projectors. The scale of the model is adjusted by varying the projection distance until two horizontal control points are plotted at the correct distance apart on the coordinatograph.

Bridging or control extension can be performed by replacing the first diapositive of a strip of photographs with the third one, reversing the optical system with a single motion of a knob, and repeating relative orientation by moving only the projector in which is the third photograph. Subsequently, the second diapositive can be replaced with the fourth, etc.

The accuracy of the stereoplanigraph is considered to be equal to, or greater than, the photographs. The instrument is generally regarded as being at least three times as accurate as the multiplex. On this basis, equivalent contouring can presumably be done at a flying height of three times that generally used with the multiplex (or about 1500 times the contour interval), and bridging can be done three times as far (or about 30 photographs). Inasmuch as our experience with the instrument is relatively meager and control points have been sufficiently close together, extreme flying altitudes and long instrumental bridging have not been attempted.

## CHAPTER 7 RECORDS AND REPORTS

This chapter is devoted primarily to the preparation of records and reports which originate in photogrammetric offices, that is, during the map compilation stage, or which must be completed at that stage. To complete the record, however, all records and reports for photogrammetric mapping are listed in Table 7 1, and some pertinent explanations are included in Section 71, instructions for the preparation of Field Inspection Reports are included in Section 72, The Descriptive Report

The necessity for clear and comprehensive but concise records and reports of the field surveys and of the office operations in photogrammetric mapping cannot be over-emphasized. No matter how complete and satisfactory the field work and the office compilation are, the value of a map manuscript is impaired if the records and reports are incomplete, unintelligible, or inadequate in any respect

Each map is usually the product of the combined work of two or more field parties, a photogrammetric office, and the Washington Office. Consequently, if the combined records and reports are to be adequate, the person responsible for each operation must see that his records and reports are complete and correct, are properly cross-referenced, and are submitted in accordance with the instructions

All records and reports that apply specifically to one map manuscript, or to a group of two or more map manuscripts, shall show clearly the registry number, or numbers, of the maps to which they apply, and shall also show the project or sub-project number

Additional instructions for records and reports originating with photogrammetric field survey parties will be found in **Volume I** of the Topographic Manual

### 71 RECORDS AND REPORTS FOR PHOTOGRAMMETRIC MAPPING

The records and reports required for photogrammetric mapping are listed in Table 7 1. This table shall be consulted by photogrammetric offices and field parties before preparing records and reports for transmittal. Records and reports are discussed briefly in subsequent headings of 71 and detailed instructions for the preparation of Descriptive Reports are contained in Section 72



TABLE 7 1—Records and Reports

Name of record or report	Origin <sup>1</sup>	Where completed <sup>1</sup>	Accompanies data for compilation <sup>2</sup>	Forwarded directly to Washington Office <sup>3</sup>
1 Monumented horizontal and vertical control of third order or higher accuracy <sup>4</sup> -----	II			X
(a) <i>Triangulation</i>				
In all cases where the method of repetitions is used				
Form 24a List of Directions				
Form 25 Computation of Triangles				
Form 27 Position Computation (or Form 26a or Form 738)				
Form 28B Geographic Positions (or Form 709)				
Form 250 Observations of Horizontal Angles				
Form 525 Description of Triangulation Station				
Form 526 Recovery Note Triangulation Station				
Sketch on transparency				
And, when applicable				
Form 26a Position Computation machine (replacing Form 27)				
Form 251a Observations of Horizontal Directions (replacing Form 250 when direction instrument is used)				
Form 274 Sketch Book				
Form 470 Abstract of Directions				
Form 655 Computation of 3 point problem				
Form 662 Inverse Position Computation				
Form 709 Plane Coordinates (replacing Form 28B)				
Form 738 Computation of Coordinates (replacing Form 27)				
(b) <i>Traverses</i>				
Form 27 Position Computation (or Form 26a or Form 738)				
Form 28B Geographic Positions (or Form 709)				
Form 250 Observations of Horizontal Angles (or Form 251a)				
Form 525 Description of Triangulation Station (for all new permanently marked traverse stations)				
Form 526 Recovery Note				
Form 590 Traverse Measurements				
And when applicable				
Form 251a Observations of Horizontal Directions (replacing Form 250 when direction instrument is used)				
Form 274 Sketch Book				
Form 589 Computation of Base Line				
Form 634 Wye Leveling } Rarely used except for higher				
Form 635 Abstract of Wye Levels } order traverse				
Form 655 Computation of 3 point Problem				
Form 662 Inverse Position Computation				
Form 709 Plane Coordinates				
Form 738 Computation of Coordinate				
(c) <i>Leveling</i>				
Form 45 Level Computations				
Form 257 Spirit Level Observations				
Form 638 Description of Bench Mark (New Bench Marks)				
Form 685 Condition of Bench Mark (those searched for)				
Sketch				
2 Horizontal and vertical control of less than third order accuracy and/or unmonumented (Applicable records as listed in 1 above with the exclusion of Forms 525 and 638) <sup>4</sup> -----	II		X	
3 Form 524 Description of Topographic Station -----	II	III	\	
4 Field photographs <sup>5</sup> -----	IV		X	
5 Office photographs -----	IV		X	

TABLE 7 1—Records and Reports (Continued)

Name of record or report	Origin <sup>1</sup>	Where completed <sup>1</sup>	Accompanies data for compilation <sup>2</sup>	Forwarded directly to Washington Office <sup>3</sup>
6 Identification cards - Form M 2226 12 -----	II		X	
7 Landmarks Form 567 <sup>5</sup> -----	II	III		X
8 Coast Pilot Report - -----	II			X
9 Special report on dangers to navigation <sup>6</sup> -----	II			X
10 Geographic Names Report - -----	II			X
11 Boundary Report <sup>7</sup> -----	II			X
12 Land Line Report <sup>7</sup> -----	II		X	
13 Descriptive Report <sup>7</sup>				
Data Record, Form T 1 -----	II	III IV	X	
Field Inspection Report -----	II		X	
Radial Plot Report -----	III		X	
Compilation Report -----	III		X	
Field edit Report -----	II		X	
Summary of Accuracy Tests -----	II			X
Washington Office Review -----	IV			
14 Supplemental Maps <sup>4</sup> -----	II		X	
15 Supplemental planetable surveys <sup>4</sup> -----	II		X	
16 Field edit Sheet <sup>7</sup> -----	II		X	
17 Map manuscript -----	III			
18 Cost Reports <sup>5</sup> -----	II III			X
19 Progress Reports - -----	II III			X
20 Statistical Reports <sup>5</sup> -----	II			X
21 Season's Report <sup>5</sup> -----	II			X

## NOTES

<sup>1</sup> Roman numerals indicate where the report or record originates and where it is completed if not completed originally (II) Field Party (III) Photogrammetric Office (IV) Washington Office

<sup>2</sup> The mark in this column indicates that the record or report accompanies other data for manuscript compilation and thus is forwarded by field parties to the photogrammetric office at which the maps are to be compiled

<sup>3</sup> A mark in this column indicates that the report or record is forwarded directly to the Washington Office

<sup>4</sup> Applicable to all types of mapping but may not be necessary on some projects

<sup>5</sup> Required for all projects unless specified otherwise in the project instructions

<sup>6</sup> This report is not required for any particular type of map or project but shall be submitted by any field party at any time that uncharted dangers to navigation are found in the field

<sup>7</sup> Not required for shoreline surveys unless specified by letter or project instructions

## 711 CONTROL RECORDS AND REPORTS

Large photogrammetric mapping projects are usually subdivided into convenient areas for programing the field and office work and for the preparation and submission of records. Control surveys are then completed in one subdivision of the project and the records are forwarded immediately to a photogrammetric office, so that the radial plots or stereoscopic instrument compilation for that part of the project can be started. The term "control records," as used in this paragraph, includes Items 2, 3, 4, and 6 in Table 7 1. The field photographs forwarded with the control records may be limited to those on which the control stations have been identified.

Geodetic records, that is, records pertaining to monumented control surveys of third-order or higher accuracy, as listed in Item I of Table 7 1, and including reports on geodetic surveys, are forwarded directly to the Washington Office, where they are filed in the Division of Geodesy. When such records are a part of a photogrammetric mapping project, carbon copies of the following records shall be made by the field party and forwarded directly to the appropriate photogrammetric office with the data discussed in the preceding paragraph:

- Form 28B List of Geographic Positions (or Form 709 Plane Coordinates)
- Form 525 Description, Triangulation, or Traverse Station
- Form 526 Recovery Note, Triangulation, or Traverse Station
- Form 45 Level Computations
- Form 638 Description, New Bench Mark
- Form 685 Condition of Bench Mark
- Sketch (may be requested from Washington Office)
- Report

Unmonumented stations located by geodetic methods are not included in this category but are part of Item 2 in Table 7 1 and all records relative to them are forwarded directly to the photogrammetric offices with the field photographs on which they have been identified.

## 712 PHOTOGRAPHS

In transmitting data between field parties, photogrammetric offices and the Washington Office, certain records must be grouped to permit continuity of operations and to avoid delaying the work. This applies particularly to photographs.

When the control records for a project subdivision are forwarded to a photogrammetric office, they must be accompanied by field photographs showing the identification of the control stations, as explained in 711. Likewise, when the remainder of the field work is completed in that subdivision of the project and the field data are forwarded to the photogrammetric office, the field photographs for that subdivision of the project must be included.

When manuscripts are forwarded from a photogrammetric office to the Washington Office for office inspection prior to field edit, they must be accompanied by all the pertinent field photographs, and these same field photographs must be forwarded by the Washington Office to the field editor with the copies of the manuscripts prepared for his use.

When field-edit records are forwarded to the photogrammetric office for the application of field-edit corrections to the manuscript, these records must be accompanied by the field photographs pertaining to the particular manuscript or manuscripts.

When the corrected manuscripts are forwarded to the Washington Office for final review, they must be accompanied by all pertinent field and office photographs.

The transmittal of photographs, as required above, requires careful planning by the field parties, the photogrammetric offices, and the Washington Office, so that no photographs are retained for use in adjoining maps. On single-lens mapping projects, duplicate sets of field photographs are furnished to facilitate the necessary transfers, and on nine-lens mapping projects, duplicate photographs are furnished at least in part. Additional copies of photographs which may be required may be requested and will be furnished if facilities permit.

## 713 NAUTICAL CHART DATA

Photogrammetric mapping of coastal areas always includes the collection of special data for the construction and maintenance of nautical charts. These records, Items 7 to 9 of Table 7 1 shall be submitted in accordance with the following paragraphs.

*Landmarks, Form 567*—The Report on Landmarks for Charts shall be submitted in accordance with heading 8534 of the Hydrographic Manual, with the exceptions stated in these instructions.

A Report on Landmarks for Charts on Form 567 shall be submitted by each field party making photogrammetric field surveys prior to compilation, unless otherwise specified in the project instructions. A Report on Landmarks for Charts is not required of field-edit parties unless specified in special or project instructions from the Washington Office. This field Report on Landmarks shall cover an entire project or a convenient subdivision of a project (see first paragraph of 711), the report shall not be submitted separately for each map. Where a comparatively large mapping project is subdivided for the submission of field inspection records to a photogrammetric office, the Report on Landmarks should ordinarily be submitted in accordance with the same project subdivisions.

The Report on Landmarks, Form 567, shall be prepared in quadruplicate by photogrammetric field parties. The original and two copies of the report shall be forwarded to the Washington Office as soon as the field work on the project, or a subdivision of the project, has been completed, the original shall be marked "Nautical Chart Branch", one carbon copy shall be marked "Coast Pilot Section", and one carbon copy shall be marked "Photogrammetric Review Section". The fourth copy of the report shall be forwarded to the photogrammetric office, preferably with the field-inspection records for that subdivision of the project.

Landmarks and aids for aeronautical charts shall also be reported in quadruplicate on Form 567, but in a separate report from the one for nautical charts. The original and two carbons of each such report shall be forwarded to the Washington Office, the original shall be marked "Aeronautical Chart Branch", one of the carbon copies shall be marked "Nautical Chart Branch", and one shall be marked "Photogrammetric Review Section". The fourth copy shall be forwarded to the photogrammetric office with the field-inspection records.

When the position of a landmark is to be determined in the photogrammetric office, the field party shall list the approximate position to tenths of minutes on Form 567.

When chart sections are submitted in accordance with heading 8534 of the Hydrographic Manual, only one set of chart sections need be prepared and these shall be attached to the original copy of the report on Form 567. Landmarks for which only approximate positions are available may be indicated on the chart sections by circles without the center dots or marks indicating the exact positions.

When the photogrammetric manuscript is compiled, the photogrammetric office shall rearrange the list of landmarks by maps and shall submit a report on Form 567 for each map within the limits of which landmarks have been recommended by the field party. This report shall be submitted in triplicate, the carbon copies shall be inserted in the original and duplicate Descriptive Reports and the original copy, marked "Nautical Chart Branch", shall be forwarded to the Washington Office with the Descriptive Report.

The report on landmarks and aids for aeronautical charts on Form 567 shall be rearranged by maps but on separate sheets from the nautical chart report and shall be prepared in quadruplicate, one carbon copy shall be inserted in the original Descriptive Report and one in the duplicate Descriptive Report, and the original marked "Aeronautical Chart

Branch" together with one carbon copy marked "Nautical Chart Branch" shall be forwarded to the Washington Office with the Descriptive Report

The photogrammetric office need not recopy and resubmit the field party's report on Form 567 for landmarks to be deleted. However, any landmarks found during compilation to have been destroyed and that were not so reported by the field party shall be reported by the photogrammetric office on a separate copy of Form 567, this report shall be prepared by map limits and submitted in accordance with the preceding paragraphs

The Report on Landmarks prepared in the photogrammetric office need not include chart sections

When the field surveys and compilation for a photogrammetric mapping project are performed under the same Chief of Party, the Reports on Landmarks shall be submitted to the Washington Office as specified in the preceding paragraphs, the Report on Landmarks resulting from the field work shall not be held in the photogrammetric office until the manuscripts are completed

When one or more landmarks on a map require further investigation during field edit, this fact shall be noted on the forms submitted with the Descriptive Report to the Washington Office and, after completion of field edit, these specific landmarks shall be reported again on a new copy of Form 567

*Coast pilot report*—(See subject 912, Hydrographic Manual) Coast Pilot Reports shall be prepared in triplicate by photogrammetric field parties. The original and one copy shall be forwarded directly to the Washington Office. The third copy shall be forwarded to the photogrammetric office with the field inspection data

*Navigational information*—(See subject 852, Hydrographic Manual) Letters or reports on navigational information are forwarded directly to the Washington Office, but copies of these shall be included in the photogrammetric data forwarded to the photogrammetric office when the letter or report contains information affecting the compilation of the map manuscripts

*Bridge data*—Bridge data shall be forwarded to the photogrammetric office, with these exceptions

(1) A copy of each letter to the local District Engineers, listing differences between field measurements of bridges and the data published in the "List of Bridges Over the Navigable Waters of the United States," shall be forwarded immediately to the Washington Office. An additional copy of each such letter shall be included with the bridge data forwarded to the photogrammetric office

(2) Where the measured clearances of bridges differ from those on a nautical chart, but are in agreement with the data in the Bridge Book, or are for bridges or cables not listed in the Bridge Book, these cases shall be reported immediately by letter to the Washington Office. A copy of this letter shall be included with the bridge data forwarded to the photogrammetric office

*Aids to navigation*—Fixed aids to navigation and their positions are reported on Form 567 (see 8532, Hydrographic Manual) and the forms are prepared and distributed according to the instructions for landmarks under this subject. Floating aids to navigation are located and reported only when specifically required in project instructions

#### 714 SPECIAL REPORTS

The field-inspection reports discussed in 724 are usually supplemented by one or more of the special reports listed as Items 10 to 12 inclusive of Table 71. These special reports shall be submitted in accordance with the following paragraphs

*Geographic names report*—The complete Geographic Names Report accompanied by the corresponding geographic name sheets shall be forwarded directly to the Washington Office. Duplicate copies of these are not required. Geographic-name information required for map compilation will be furnished to the photogrammetric offices by the Administrative Planning Section of the Division of Photogrammetry.

Geographic-name reports are prepared to cover convenient subdivisions of a project, or the entire area of a small project, and not individual maps. On a large mapping project, these reports should be prepared to cover convenient project subdivisions (see first paragraph of 711). This is necessary so that the information will be available to photogrammetric offices when the map manuscripts are compiled.

*Boundary reports*—On most planimetric and topographic map projects, it is not practical to include the report on boundaries in the field inspection report, and this information must be submitted as a special report to cover a convenient subdivision of the project. When photogrammetric office compilation, Washington Office inspection and review, and field edit are in progress simultaneously in a project, three copies of each boundary report are needed. Consequently, boundary reports should be typed in triplicate when practicable and all copies of each report, together with the maps accompanying it, should be forwarded directly to the Washington Office. Photostats of the maps will then be made and attached to each copy of the report by the Administrative Planning Section. One copy of the report will then be forwarded to the photogrammetric office, one copy to the Review Section, and one to the field editor. Boundary reports often contain voluminous excerpts from official State or county records. If carbons of these records cannot be obtained without considerable extra expense or if for other reasons copies of a report cannot be prepared without undue labor or expense, only one copy of the report need be prepared and this shall be forwarded directly to the office at which the maps are to be compiled.

*Report on land lines*—Land line information applicable to a map or small group of maps, will be included in the field inspection report. However, a special report on land lines to include information applicable to the project as a whole, or a large section of a project, is often desirable. When such a special report on land lines is needed it shall be prepared in triplicate. The original shall be forwarded to the photogrammetric office and two copies to the Washington Office, one copy will be used in the Review Section and the other furnished to the field editor. The copies of plats and descriptions of corners, etc., shall be forwarded directly to the photogrammetric office. The plats and other data must accompany the manuscripts when the latter are forwarded to the Washington Office for office inspection and field edit. When duplicate copies of land line records, other than the special reports mentioned above are required, the material may be submitted to the Washington Office for photostating.

#### 715 MAP MANUSCRIPTS AND ACCOMPANYING DATA

Topographic and planimetric manuscripts forwarded to the Washington Office for inspection prior to field edit, shall be accompanied by the Descriptive Reports (see 72), discrepancy overlays, field photographs, and any other records required in connection with specific investigations called for on the discrepancy overlay, as for example, the records pertaining to a landmark, a boundary, or other item which is to be investigated and completed by the field editor. Office photographs and other records not specifically mentioned in this paragraph need not be forwarded to the Washington Office at this time.

The data forwarded to the field for use in field edit, shall include copies of the manuscript, a discrepancy print prepared by the Review Section from the discrepancy overlay, the field photographs, the Descriptive Report, and such other records as may be needed for investigation of items called for on the discrepancy print. After the field edit has been completed, the field-edit sheets and accompanying records shall be forwarded directly to the photogrammetric office in which the manuscript was compiled, except that the summary of accuracy tests and all records pertaining to accuracy tests shall be forwarded directly to the Washington Office. Occasionally the field editor will be instructed to forward all field-edit data for a manuscript, or a number of manuscripts, to the Washington Office for a preliminary examination, after which the data will be transmitted to the photogrammetric office. This latter shall be done only on written instructions from the Washington Office.

The results of the field edit will be applied to the map manuscript in the photogrammetric office, unless otherwise instructed by the Washington Office.

Completed manuscripts—that is, shoreline surveys after the photogrammetric office review, and topographic and planimetric maps after application of field-edit data—shall be forwarded promptly to the Washington Office, with all accompanying records and reports, including both the office and field photographs.

## 716 COST AND PROGRESS REPORTS

Unless otherwise specified in the project instructions, or by letter from the Washington Office, the following cost and progress reports shall be submitted to the Washington Office monthly by each field party and each field photogrammetric office for each project on which the field party or photogrammetric office is currently engaged.

*Progress sketches*—A progress sketch shall be submitted in compliance with paragraph 261 of the Regulations for each project to show graphically the status of work at the end of the month. Progress sketches shall be forwarded to the Washington Office immediately after the end of the month.

Progress of all photogrammetric mapping projects is shown on graphic progress reports brought up to date monthly by the Washington Office. Copies of reports—of projects in progress by each field party and each photogrammetric office will be furnished and each shall be brought up to date in red ink and mailed to the Washington Office on the last day of the month—by air mail if more than 500 miles distant.

*Preliminary monthly report*—A preliminary report shall be forwarded monthly to the Director, in compliance with paragraph 260 of the Regulations, by each field party and field photogrammetric office, so as to reach the Washington Office by the 25th of that month. This report shall comprise a brief summary of activities of the party or office during the month, including special activities in addition to assigned mapping projects, a discussion of any special problems which should be called to the attention of the Washington Office, or which are of special significance or interest in connection with the work of the party, and a listing of personnel changes.

The preliminary monthly report submitted by the photogrammetric office shall also include a statistical summary of mapping progress on Form M-2372-12(1).

The preliminary monthly reports inform the Washington Office of project progress and of special problems encountered in field surveys, and thus are an important means of liaison between field parties and field offices and the Washington Office. The reports may be informal in content and format, and Chiefs of Party should not hesitate to discuss freely important conditions and problems confronting them.

*Cost accounts*—The unit monthly summary of costs for each mapping project or each subproject shall be submitted by each field party and field photogrammetric office so as to reach the Washington Office by the tenth of the next month. This cost summary shall be made in accordance with the pamphlet, Revised Edition January 1942, MAP PRODUCTION, PERFORMANCE AND COST ACCOUNTING for PHOTOGRAMMETRY and PLANETABLE SURVEYING, amended as follows. The cost of all field work done prior to manuscript compilation shall be included in Items 31 to 33 inclusive, and the cost of field work done after manuscript compilation, that is field-edit costs, shall be included in Items 34 and 35.

For topographic mapping projects an additional cost entry entitled "NC" shall be made and shall include the costs of all operations, field or office, that are specifically required to meet the needs of nautical charts or of hydrographic surveys and that would not normally be required in standard topographic mapping. Typical work items that are included in this category are

- 1 Field inspection and/or field edit of the shoreline and offshore details including the foreshore
- Compilation of offshore details but not compilation of the shoreline and foreshore areas
- 2 Recoverable topographic stations
- 3 Photo-hydro stations
- 4 Aids to Navigation
- 5 Landmarks for charts
- 6 Bridge and cable clearances
- 7 Coast Pilot inspection
- 8 Maintenance of control stations, i.e., re-marking or moving and relocating horizontal and vertical control stations, and so forth

The costs to be included under nautical charts "NC" shall be separated daily by estimation and entered on the daily time cards. In no case shall the separation of these costs be left until the end of the month. These instructions are purposely general rather than exact and must be applied with understanding and judgment. Each Chief of Party, or officer in charge of a photogrammetric office, shall instruct and supervise employees keeping this record to insure a reasonably correct separation of nautical charting costs.

These cost accounts shall be submitted for each project as a whole, unless the project instructions specify subdivisions of the project for cost accounting purposes.

#### 717 STATISTICAL AND COST DATA

In addition to the reports specified in 716, each Chief of Party shall submit a monthly report and journal of field party on Form 20A in compliance with paragraph 259 of the Regulations and, at the end of the fiscal year, an annual statistical report on Form M-1133-5 in compliance with paragraph 257 of the Regulations.

#### 718 SEASON'S REPORT

A Project Report shall be prepared and forwarded to the Washington Office by each chief of a photogrammetric field survey party at completion of each mapping project on which field work has been continuous. And when field work on a project is seasonal, and all work on the project is discontinued for a period of several months, or longer, a Season's Report for the project shall be submitted at the end of the field season.

The following information should be included in the Project or Season's Report

- (a) The project number and the name of the officer or employee submitting the report, at the top of the outside cover



(b) Dates of original and supplemental instructions and dates of beginning and ending field work

(c) A brief chronology of the activities of the party

(d) A brief mention of any important activities, such as special surveys that are not a part of the project

(e) The general organization of the party, including a list of all Commissioned and Civil Service personnel and the general capacity in which each was employed, giving any dates of reporting or detachment. The number of A 6 112(C) (2) employees should be given, without tabulating them by name, including any significant changes in the total number.

(f) A brief summary of the methods employed in executing the field work and, particularly, a description of any special methods employed to solve unusual problems encountered.

(g) A discussion of the adequacy of instruments, materials, and equipment for the work and recommendations for changes for similar projects.

(h) Tabular statistics of significance for the project as a whole or for that part completed at the date of the report, including area contoured or field inspected, miles of shoreline, miles of traverse, miles of leveling, number of control stations searched for, recovered, and identified, number of recoverable topographic stations established, number of photohydro stations identified, etc.

(i) A progress sketch, similar to the monthly progress sketch, summarizing accomplishments.

(j) When the project is incomplete, a summary of the field work left to be done, with explanations and recommendations which will be helpful to another Chief of Party who may be assigned to complete the project some time in the future.

These reports are for use of the Washington Office in planning future similar mapping projects or in planning for the resumption of an interrupted project. They are not for map compilation purposes and, consequently, should not include information contained in the field-inspection reports.

Where the field-inspection report (see **724**) covers an entire season's work, as, for example, on most Alaska projects, the Season's Report and the field-inspection report may be combined. In this case several copies of the report must be submitted, as specified in **724**, otherwise only one copy of a Season's Report is required.

## 72 THE DESCRIPTIVE REPORT

A Descriptive Report shall be prepared to accompany *each* topographic map, planimetric map, and shoreline survey, but the field inspection and photogrammetric plot sections of a descriptive report may cover a group of maps and may be merely cross referenced in other descriptive reports of the group (see **724** and **725**). Descriptive Reports shall be prepared and arranged in accordance with the instructions contained in this Section. For the sake of continuity in discussing Descriptive Reports, instructions for field inspection reports are included in this Section. The instructions for field inspection reports contained herein, may be supplemented by more detailed instructions in Part I of the Topographic Manual, particularly as to the special reports which often accompany them (**724**).

The Descriptive Report is for the purpose of supplementing—not duplicating—information that is evident on the map. The Descriptive Report shall be concise and repetitious statements shall be avoided.

The numbers and side headings specified in this Section shall be used in all Descriptive Reports. It is to be noted that numbers 2 to 20 inclusive apply to the field inspection report,

numbers 21 to 30 inclusive to the radial plot report, numbers 31 to 50 inclusive to the Compilation Report, numbers 51 to 60 to the Field-edit Report, and numbers starting with 61 to the Washington Office Review, and they shall not be used in headings in other places, nor repeated as headings. Any number and side heading that are inapplicable shall be tabulated with the sole comment "Inapplicable." Where consecutive side headings are inapplicable, they shall be grouped together, as, "No 35 through No 38—Inapplicable." The precaution of tabulating all side heading numbers instead of omitting inapplicable ones is so that no side heading will be inadvertently overlooked. Extra numbers are provided for the insertion of any special items for which no provision has been made.

Any phase of the work, or any item that is common and applicable without qualification to two or more contiguous maps within a project or subproject, should be described in only one Descriptive Report and not be repeated in each Descriptive Report, but cross-reference under each appropriate side heading in other Descriptive Reports must refer by map number to the appropriate Descriptive Report containing the full text.

Each Descriptive Report shall contain references to all the separate reports applicable to that particular map.

Many past Descriptive Reports have been unnecessarily voluminous, verbose, and repetitive, on the other hand the essential information has often been omitted. Most reports have been filled with general statements of self-evident information.

Project instructions are prepared for each project and detailed instructions for field operations and for compilation are contained in this Manual. Where the operations comply fully with the project instructions, with the instructions contained in this Manual or with subsequent amendments, and are considered to be standard procedures they need not be mentioned at all in the Descriptive Report. It is the abnormal, the unusual, the departure from standard practice, that should be brought out in a Descriptive Report.

Those preparing Descriptive Reports must understand that there is no obligation to "pad" the text with self-evident or nonessential information simply to fill up pages. Descriptive Reports have to be read numerous times by numerous people after they have been written and it is simply boring to read statements that are self-evident, and unnecessary information which only tends to obscure the important facts. Side headings are provided for convenience in arranging the text in a standard manner and so that no subjects will be overlooked. There is no expectation that text will be required for each side heading in each Descriptive Report, in fact it would be an unusual case in which there would be important facts that should be stated opposite each side heading. Under some conditions a Descriptive Report may need to be comparatively long, but in most cases the briefer it is the better as long as no essential information is omitted.

Those writing Descriptive Reports should try to put themselves in the position of the reader and include in the Descriptive Report information that the reader might need to supplement the map, particularly with respect to unusual conditions of terrain, of culture, of methods, and of results.

Important deficiencies in past Descriptive Reports have been (a) Most of the statements were self-evident, (b) Repetitive phrases or statements occurred numerous times in the same report or in numerous Descriptive Reports in the same project, (c) Repetitive phrases such as "within the limits of this map manuscript" (Every statement in a Descriptive Report should be assumed to so apply—it is the contrary statement that is needed occasionally), (d) Repeated statements that the compilation was based on information furnished by field inspection parties (the field inspection party furnishes this information for just this purpose—it is only when such information is not furnished, is inadequate, or

is found to be incorrect, that a statement is needed), (e) Statements that certain features were not delineated because they were not reported by the field inspection party nor were they visible on the photographs (when it is evident that the feature does not exist, a simple statement to that effect should be made), only when it is believed that the feature does still exist, but the compilation office has no data from which to delineate it, should such a statement as the above be made, and (f) Omission of information needed by the chart compiler or others using the map who do not have access to the photographs and are not familiar with the project

## 721 SEQUENCE OF CONTENTS

Form 504, Descriptive Report, shall be used as the outside cover sheet of each report. The body of each Descriptive Report shall consist of

- I Data Record (Form T-1)
- II Field Inspection Report
- III Photogrammetric Plot Report
- IV Compilation Report
- V Photogrammetric Office Review (Form T-2)
- VI Geographic Name List
- VII Field-edit Report
- VIII Washington Office Review

### 7211 Signatures and Responsibility

Each Chief of Party is responsible for the work done under his direction and shall sign that section of the Descriptive Report corresponding to the work under his direction. In addition, the Chief of Party may have *one* other employee in his party sign the report before his signature. At the discretion of the Chief of Party this may be the employee directly responsible for most of that phase of the work or this may be a supervisor. No more than two signatures shall be affixed to any section of the Descriptive Report.

The Chief of Party may have that section of the Descriptive Report for which he is responsible written by anyone in his party at his discretion. The employees directly involved in any operation should be encouraged to learn to write adequate reports, but the Chief of Party should use his discretion as to whether the actual text is prepared by this employee or whether it is written by someone else and based on notes kept by the employee. In any event, each section of the Descriptive Report should be prepared by someone who is thoroughly familiar with that phase of the work, although the text should be carefully examined by the Chief of Party in order to insure that there have been no important omissions. Where more than one employee has been engaged on a particular phase of the work consideration should be given to having the supervisor of the several employees prepare the report or at the discretion of the Chief of Party the preparation of the report may be delegated to one, but to one only, of the several employees.

Where field inspection or field edit is done by detached parties that are only nominally supervised by the Chief of Party the Descriptive Reports for these operations must be prepared by the employee in immediate charge of the field operations. It is realized that the Chief of Party in such cases cannot be as directly responsible for such operations even though he is expected to supervise the operations as well as practicable from a distance, and he may sign such a report as "Approved and forwarded," if he so desires.

*7212 Copies Required*

Each Descriptive Report, including all parts, forms, and insertions of the report shall be prepared in duplicate, exclusive of any copies retained in the files of the originator of the report. Further, where the field inspection report or the compilation report covers more than one map, an original and two copies of the field inspection report or the compilation report are required in addition to any retained in the originator's files.

Only one original and one duplicate of the photogrammetric plot report and of the field-edit report are required, in addition to copies retained in the files of the originator, even though the photogrammetric plot report may cover more than one map.

Form M-2388-12 which is a tabulation of control stations, and is considered a part of the photogrammetric plot report, shall be prepared separately for each map and the original and one duplicate are needed.

*7213 Pagination*

The pages of a Descriptive Report shall be numbered consecutively from beginning to end, with the exception of certain inserts mentioned below. The introductory statement (see **7232**) shall always be page No 6. The first page of the field inspection report shall always be page No 7. Each page thereafter, including sketches, forms, etc., shall be numbered consecutively.

If a page-size progress sketch is available and is inserted it will be page No 5. The Data Record, Form T-1, comprises 4 pages which shall be numbered 1 to 4, if a progress sketch is included, otherwise they shall be numbered 2 to 5.

Page numbers shall be typed or printed in the upper right-hand corner. The purpose of systematic pagination, without duplication, is to facilitate reference to any part of the report.

Copies of pertinent correspondence, notes for the hydrographer (item 49), and any informal report by the field party to the photogrammetric office or by the photogrammetric office to the Washington Office shall be inserted in an appropriate place in the Descriptive Report, but these pages shall not be considered in the consecutive page numbers of the report. The informal report to the photogrammetric office and that to the Washington Office are removed from the Descriptive Report and destroyed after they have served their purpose. The notes for the hydrographer are frequently extracted and sent to hydrographic parties or used for other purposes.

*7214 Assembly*

A Descriptive Report is usually not assembled and bound in Form 504 until after the compilation has been completed and the photogrammetric office review prepared. Normally Form 504 will be completed at the photogrammetric office at which time items I to VI as listed in **721** shall be assembled and bound.

Where the field inspection report covers a complete season's work as in some Alaska projects, or covers a large number of maps and is too voluminous for convenient binding in any one Descriptive Report, it should be submitted separately, but reference to it should be made in each Descriptive Report to which it applies. This reference shall be entered under the unnumbered side heading "*Field inspection report*," just preceding the first numbered heading of Compilation report (**726**).

When a map manuscript is forwarded to the Washington Office, two copies of the corresponding Descriptive Report shall accompany it. If the Descriptive Report includes a field inspection report or compilation report prepared to cover more than one map and

the other maps involved have not been completed, the triplicate copy of the pertinent part of the report shall be retained by the photogrammetric office. Where a field inspection report involving a number of maps is bound separately, the original and one copy of the report shall be forwarded to the Washington Office with the first map manuscript to which it applies. The triplicate copy in such case shall be retained in the photogrammetric office until all map manuscripts to which it applies have been completed, after which it shall be forwarded to the Washington Office. (See 7212.)

## 722 COVER, FORM 504

The appropriate entries on Form 504 shall be typewritten and shall be in accordance with the following instructions (see fig 7 1)

<small>F 504 504</small> U S COAST AND GEODETIC SURVEY DEPARTMENT OF COMMERCE <b>DESCRIPTIVE REPORT</b>
Type of Survey <small>(a)</small> _____
Field No <small>(b)</small> _____ Office No <small>(c)</small> _____
LOCALITY
State _____
General locality _____
Locality _____
194 <small>(d)</small> _____
CHIEF OF PARTY
<small>(e)</small> _____
LIBRARY & ARCHIVES
DATE <small>(f)</small> _____

FIGURE 7 1—Form 504 Descriptive Report Cover

- (a) The type of survey is
- (1) Topographic
  - (2) Planimetric
  - (3) Shoreline—(Photogrammetric or Planetable)
  - (4) Graphic control
- (b) Field No  
Leave blank for photogrammetric surveys
- (c) Office No  
Enter the assigned registry number
- (d) Year
- (1) The date on the form shall be the date of the field edit
  - (2) When there is no field edit, the date shall be that of the field inspection
  - (3) When there is neither field inspection nor field edit, the date shall be that of the photographs

(e) When the field work preceding office compilation has been done under the direction of one Chief of Party or Officer-in-Charge and the office compilation has been done under the direction of another, the names of both shall be entered on Form 504. The following are the two principal cases that occur

(1) Where the field work is done under the direction of one Chief of Party and all the office compilation is done at a photogrammetric office under a different Chief of Party. In this case the entries should appear as follows

John T. Doe, Chief of Party  
T. S. Baker, Photogrammetric Office

(2) Where the field work is done under the direction of a Chief of Party and all or most of the office compilation is done at the Washington Office. In this case the entries should appear as follows

John T. Doe, Chief of Party  
Division of Photogrammetry, Washington, D. C.

Field edit is to be ignored as regards these signatures. In no case are titles or rank to be shown.

(f) Leave blank

### 723 DATA RECORD, FORM T-1

Form T-1, Data Record, shall be started when the field inspection report is written and additional entries shall be made by the appropriate group as each work phase is completed. The form will be completed in the Washington Office. (See fig 72)

Entries shall be made in all applicable spaces of the form. Roman numerals indicate whether the entry is to be made by the (II) Field Party, (III) Photogrammetric Office, or (IV) Washington Office. The information required should be apparent from the form itself and no entries except the following require explanation (see fig 72)

- (a) Include the subproject number if there is one
- (b) Graphic Reading Plotter multiplex, or stereoplanigraph
- (c) Where the contouring on a quadrangle is done by more than one planetable party or by more than one stereoscopic instrument operator, a diagram showing the division of work and the name of the man responsible for the contouring of each division shall be shown
- (d) The date of location of the mean high water line shall be the date on which the mean high-water line (which is considered to be changeable) existed as shown on the map. This shall be the date of the photographs from which the mean high-water line was compiled, with these exceptions: where the mean high-water line has changed appreciably since the date of the photography and has been surveyed by any method, such as planetable, reference distances recorded on the photographs, or sextant fixes, the date of the mean high water line shall be the date of the field survey. Where more than one date of location of the mean high-water line is involved on a map the stretch of mean high-water line to which each date applies shall be defined. This may be done under the appropriate section of the field inspection report, or the compilation report, and referenced on the data record
- (e) Group the single-lens photographs together and the nine-lens photographs together
- (f) State whether the tidal data used were observed tides or computed from the predicted Tide Tables

None of the information of the Data Record should be duplicated nor is any additional statistical information required in the text of the Descriptive Report.

The names of personnel entered in the Data Record shall comprise the surname and initials—not initials only.

Dates are required for many of the items in the Data Record. These dates show the progress of the map from the date of the instructions to the reproduction date. The date of any item shall be the date of completion of that item. When field inspection, contouring, or field edit for a map has been intermittent and extended over a relatively long period as over two or more field seasons, the dates of each season's work shall be shown, and the facts stated briefly in the body of the Descriptive Report.



7231 *Layout Sketch*

If a page-size sketch showing the map layout for the project is available, the specific map which the Descriptive Report accompanies shall be outlined in red on a copy of the sketch and this sketch shall be inserted in the Descriptive Report after the data record

7232 *Preface* 7

An introductory statement for each Descriptive Report shall be prepared in the Review Section at the Washington Office and will constitute the first textual item of the Descriptive Report This will be prepared on a separate page and will immediately precede the field inspection report This page will be headed "~~Summary to Accompany Descriptive Report T-0000~~" It will be a brief paragraph of orientation, identifying the map in its relation to the project and placing it geographically It will state briefly the several major processes by which the map was prepared The following is a typical example of such a preface

"Topographic map T-0000 is one of 37 similar maps in project PH 79(49) and is the southeasterly map in the project It covers a part of the eastern shore of Penobscot Bay, Maine This is a multiplex project, in advance of hydrographic surveys to be made in the same area The field operations preceding compilation included complete field inspection the establishment of some additional horizontal control, and the determination of the numerous elevations required to control a multiplex project vertically The multiplex compilation was at a scale of 1 8,500 from which a manuscript showing shoreline, along-shore features, and photo hydro stations at a scale of 1 10,000 was prepared for use in future hydrographic surveys The manuscript consists of 2 sheets each  $3\frac{3}{4}'$  in latitude by  $7\frac{1}{2}'$  in longitude The entire map was field-edited The map is to be published by the Geological Survey at a scale of 1 24,000 as a standard topographic quadrangle" The registered copies under T-0000 will include 2 one-half quadrangle cloth-mounted prints at scale 1 10,000 identified as T-0000 N/2 and T 0000 S/2, and a cloth-mounted color print at scale 1 24,000

724 **FIELD INSPECTION REPORT**

The field inspection report may cover a single map, a group of contiguous maps, an entire sub-project, or all that part of a project covered in one field season, depending upon conditions, but in no case shall the field inspection report apply to more than one project The maps or sections of a project to be included in a single report are left to the discretion of the chief of the field party In Alaska, for example, it is normally expected that an entire season's work on one project will be covered in one report, on the contrary, in the United States it is normally expected that a separate report will be prepared for each map in a topographic mapping project where the contouring is by planetable Between the two extremes are many variations In general, the choice should be based on whether or not the terrain, the methods of surveying, and other conditions are so similar that two separate reports would be repetitious In many instances it is preferable to prepare *one field inspection report to contain all information common to a group of maps*, and in addition to prepare *a short individual report for each to contain the information and data applicable to that map only*

On many large projects, particularly those in the United States, photogrammetric office compilation and the Washington Office review both may be started while field surveys in other parts of the project are still being made In this case, each field inspection report must be so limited as to the area it covers, that it can be completed and forwarded to the photogrammetric office when, or not much later than, the compilation for that section of the project is started In these circumstances, a field inspection report should be limited to a convenient subdivision of the project as discussed in **711**



When the office compilation is not to be started until after the close of the field season, the field inspection report may include the entire season's work, and this is often done in Alaska surveys

Where a field inspection report covers a large group of maps, as a subproject or project, it usually will be too elaborate to be bound in the Descriptive Report. In this case, the report shall be bound by the field party. Field inspection reports covering a few maps, will be bound in a Descriptive Report at the photogrammetric office and need not be bound by the field party.

A field inspection report that covers more than one map shall be submitted in triplicate, unless otherwise specified by the project instructions, a field inspection report involving only one map shall be submitted in duplicate. The triplicate copy of the field inspection report is necessary because a report may be needed simultaneously in a photogrammetric office, in the Washington Office, and in the field. Regardless of the arrangement of the field inspection report—i.e., whether it covers one or several maps—Form T-1 shall be prepared in duplicate for each map, at the time the field inspection report is prepared, completed for all items marked II, and forwarded with the field inspection report.

Where a field inspection report covers more than one map, each Descriptive Report for a map involved shall contain a cross-reference to the field inspection report. Such references will be made in the photogrammetric office when the Descriptive Report is bound. Excerpts from the combined field inspection report need not be included in the individual Descriptive Reports.

Field inspection reports are often supplemented by special reports on such subjects as geographic names, boundaries, land lines (714), and sometimes control surveys. Each field inspection report shall carry references to any separate special reports applicable to that part of the project covered by the field inspection report.

The text of the field inspection report will ordinarily be arranged in accordance with side headings 2 to 14, as listed below, and extra numbers 15 to 20 which are provided for unlisted subjects. All field operations completed prior to map compilation shall be covered in the field inspection report or in special reports referenced therein. Where a side heading is not applicable, it shall be listed with the comment "inapplicable." Where a particular item of field inspection is incomplete, or has been deliberately left for field edit, that fact shall be stated under the appropriate side heading. Information given in the field inspection report shall not be duplicated in any other part of the Descriptive Report.

**2 Area/field inspection**—Under this heading describe the area, make general statements about the field inspection, and the quality of the photographs, including any particular items of historical interest.

The area should not be defined (that will be done in paragraph I (see 7232)), but it should be described briefly with particular attention given to the salient natural and cultural features.

State whether any part of the field inspection is substandard and call attention to any unusual methods used or unusual features of the terrain and specifically itemize any items left to be completed during field edit.

If the photography was substandard in any respect, give particulars, including any general information regarding photographic interpretation that will be of help to the compiler, as, for example, where certain photographic tones or densities indicate specific types of vegetation or other natural features peculiar to this particular area.

**3 Horizontal control**—Give pertinent information that will be useful to the photogrammetric office in making the photogrammetric plot and to the Washington Office in reviewing and editing the map. Include any of the following items that are applicable

(a) List by stations or traverse lines all the *supplemental* control established during field inspection and give the methods used for establishment

(b) Discuss any datum adjustments made by the field party

(c) List by schemes, or stations, and agencies all control *not* established by the Coast and Geodetic Survey, with the sources and the order of accuracy Describe any adjustments made to place this control on the North American datum of 1927

(d) List any stations required by the project instructions for control of compilation which were *not* recovered or established and/or positively identified, and explain why they were omitted

(e) If all Coast and Geodetic Survey stations were not searched for, state authority for such omissions List all stations reported as "Lost" on Form 526 List any "lost" stations that were identified for use in the plot, and explain

(f) The quality of identification, that is, whether positive or doubtful, shall be stated on each identification card (Form M-2226-12), useful information regarding such station, which cannot be stated conveniently on the identification card, shall be given in the field inspection report

It is not necessary for the field party to list *all* control stations within the area of the map or even to list the control by schemes This list is to be made on Form M-2388-12, Control Station Data, in the photogrammetric office

4 *Vertical control*—Describe in general the methods used to provide vertical control for planetable contouring or for contouring by stereoscopic instruments and give important particulars, as the following

(a) List all bench marks of third-order or higher accuracy and give the following particulars

(1) The establishing agency

(2) The order of accuracy

(3) Any datum adjustments, with explanation

(4) Identify any bench marks not searched for and explain

(5) Identify any bench marks established by your party

(b) State the methods used to establish supplemental elevations Mention any lines of levels with large closures and describe the methods of adjustment

(c) List the first and last designated level point for each map

(d) List any vertical control stations required by the project instructions for stereoscopic mapping that were not established and any that were placed differently than specified, and explain

5 *Contours and drainage*—Describe the methods used in planetable contouring and state whether the contouring was done on photographs or on a planimetric map furnished for that purpose

Describe any special methods used in contouring and in mapping drainage in particular areas, as for example, in wooded areas

Discuss any special features of the terrain that are to be particularly emphasized on the map

Where contouring is done on photographs, include any information needed by the compiler that is not apparent on the contoured photographs

6 *Woodland cover*

7 *Shoreline and alongshore features*—Describe any natural and cultural features that are not self-evident and mention any that are to be particularly emphasized on the map Include information needed by the compiler which is not apparent on the field inspection

photographs Include under this side heading pertinent information on the following subjects

- (a) The mean high-water line
- (b) The low-water line
- (c) The foreshore
- (d) Bluffs or cliffs
- (e) Docks, wharves, piers, landings, etc
- (f) Submarine cables
- (g) Other shoreline structures

8 *Offshore features*—State whether any features offshore from the high-water line were actually visited during field inspection and how their elevations were determined. When rocks not visible photographically were located in position on field photographs, state how they were located. Discuss any important features such as rocks or other obstructions that require further investigation by the hydrographic party. A chart section on which these features are indicated may be included in the report, thereby reducing the length of the text. The character of the foreshore shall be indicated on the field inspection photographs, and any additional information about it that may be needed by the compiler shall be included in the field inspection report. Discuss the accuracy with which the mean low-water line was identified.

9 *Landmarks and aids*—Include any pertinent information regarding the following: (a) Landmarks for nautical charts, (b) Interior landmarks, i.e., outstanding interior features or objects of significance to those using the map, (c) Aeronautical aids, (d) Fixed aids to navigation, and (e) Floating aids to navigation. Do not repeat information that is self-evident from Form 567. Discuss any unusual methods used in locating fixed aids, and state the methods used to locate floating aids. List any aids to navigation that are to be located during field edit.

10 *Boundaries, monuments, and lines*—Information and data on boundaries will ordinarily be submitted in a special report (see 714), and the field inspection report shall include a reference to the special report. But where the boundary information is not sufficiently voluminous to warrant a special report, it may be included in the field inspection report. In this case, references shall be made to all maps or plats not bound in the report.

Information on the public-land system and section and township corners will normally be submitted in a special report (see 714), which will be referred to here. State the number of section corners recovered and identified within the limits of each map.

11 *Other control*—Include under this heading pertinent information about recoverable topographic stations and photo-hydro control. List by name only, all recoverable topographic stations that have not been reported as landmarks or aids to navigation on Form 567. If the project instructions for the spacing of recoverable topographic stations or photo-hydro stations could not be complied with, explain.

12 *Other interior features*—Include here any pertinent information about any natural or cultural features not specifically provided for under previous headings. Road classification, buildings and structures, bridges and cables over navigable waters, airports and landing fields, are a few of the subjects to be considered.

Bridge and cable data shall be included in the field inspection report for all maps covered by that report. The tabulated data shall be accompanied by description of any special conditions which the compiler must know about to compile accurately the bridges and their clearances on the manuscript. Include with the report copies of any reports to the Local District Engineer or to the Washington Office regarding discrepancies in bridge or cable clearances.

13 *Geographic names*—Refer to the special report on geographic names and give the date it was forwarded to the Washington Office. Include any additional information on geographic names that may have been unearthed since the report was prepared. If there is no special report on geographic names, include here all data on names for this map.

14 *Special reports and supplemental data*—List here each special report (see 714), each map or plat obtained in the field to assist in the compilation, and all records, with the dates forwarded and the place to which each was forwarded. Field records, record books, photographs, etc., should not be individually identified, but each transmitting letter should be separately listed. This list should appear in the separate field inspection report for each map, where such is prepared.

15 through 20 For use in numbering additional items in the field inspection report.

As previously stated, side headings and numbers inapplicable to a particular map are to be so indicated and consecutive inapplicable items will be grouped together. Information that applies to several maps should be included in only one Descriptive Report, but reference shall be made to that report in all other reports to which it applies.

*Notes for the compiler*—Occasionally it will be desirable to include in the field inspection report information for the use of the compilation office which is not of sufficient importance to become a part of the permanent record. In such cases, this information shall be placed on unnumbered pages separate from any other part of the field inspection report, and shall be entitled "Notes to the Compiler." These notes will be extracted after completion of the maps. Notes for the compiler are not required for each field inspection report and should seldom be needed. They should not include self-evident information, or information included in the text of the field inspection report.

## 725 PHOTGRAMMETRIC PLOT REPORT

A radial-plot report or a stereoscopic instrument horizontal control report shall be written to cover each radial plot or horizontal control extension by stereoscopic instruments. Although radial plots and horizontal control extensions generally cover more than one map, a report that applies to several maps shall be a part of the Descriptive Report of only one. The report shall not be duplicated in each Descriptive Report but shall be referred to in each report. This reference shall be entered under the unnumbered side heading, "*Photogrammetric plot report*," just preceding the first numbered paragraph of the compilation report. The report on the radial plot or on stereoscopic bridging shall be prepared in duplicate.

A separate report on horizontal control bridging is not required in every case for mapping by multiplex or stereoplanigraph. This information may be included in the compilation report if that is more convenient. Where horizontal control is relatively sparse and the horizontal control extensions by multiplex or stereoplanigraph are involved, a separate report is desirable, but where this work is routine without complications, the necessary information can be conveniently included in the compilation report.

The side headings 21 through 30 are for use in the photogrammetric plot report.

21 *Area covered*—List the registry numbers of all the maps to which the report applies.

22 *Method*—Describe briefly the methods used, including any or all of the following items that are applicable:

### Radial Plot

Map manuscripts and base grids  
Photographs

Preparation of photographs, including paper distortion corrections and the correction of transforming errors

Templets

Closure and adjustment to control

Transfer of photogrammetric points to the map manuscripts

### Stereoscopic Instruments

Brief general statement of methods employed

Map manuscripts

Control strips

Assembly and adjustment of strips

Transfer of photogrammetric points to the map manuscripts

Describe in detail any unusual methods employed

23 *Adequacy of control*—State whether the horizontal control provided complied with the project instructions, and whether it was adequate (see 159) Discuss in detail each control station that could not be held in the plot or in bridging and how it was disposed of In accordance with 4251, horizontal control stations not usable after all possible errors have been eliminated, shall be reported to the Washington Office Include in the report copies of this correspondence with the Washington Office

24 *Supplemental data*—List any graphic control surveys used for control of the radial plot Where these are used, discuss any important discrepancies between the graphic control survey positions and the photogrammetric positions

25 *Photography*—Discuss the adequacy of the photography as to coverage, overlap, definition, accuracy of transforming, quality of diapositives, etc List any photographs badly tilted and state whether these were rectified or whether tilts were computed In the latter case, state what points were used as radial centers

26 through 30—These paragraphs are provided for discussion of additional items

*Sketch and Form M-2388-12, Control stations*—Where the photogrammetric plot covers more than one map, each copy of the report shall include a letter size sketch showing the map limits, the photograph centers, and the control stations used in the plot Control stations specifically referred to in the report shall be specially indicated on the sketch for each reference This shall be at the end of the text of the photogrammetric plot report, immediately preceding Form M-2388-12

Form M-2388-12, Control Station Data, shall be completed for each map in a plot, a separate form listing all control on each map This form shall accompany the photogrammetric plot report and shall be later inserted in the Descriptive Report directly preceding the compilation report Duplicate copies of the form for each map are required (See 7212 )

## 726 COMPILATION REPORT

The compilation report shall be prepared by the compiler or his immediate supervisor (see 7211), although the Chief of Party is fully responsible for it Each compiler, whether in the Graphic Compilation Section or the Stereoscopic Mapping Section, shall keep notes prepared concurrently with the progress of the work on each manuscript The compilation report is to be based on these notes

A separate compilation report shall normally be prepared for each map, an original and a duplicate, in addition to any copy retained in the files of the photogrammetric office, where the report covers more than one map, triplicate copies shall be furnished

The compilation report shall not duplicate information included in the field inspection report or photogrammetric plot report, but may supplement such information if it is desir-

able to do so. Where this is necessary, the supplemental information shall be included under the applicable number and side heading, or in a separate paragraph of supplemental information, using one of the numbers 41 to 45. Numbers 1 to 30 shall not be repeated in the compilation report.

The routine methods of compilation are the accepted methods, they should not be mentioned in the report. It is only where an unusual method had to be resorted to, that the method should be described. The report should include under the listed side headings or additional headings any information that cannot be shown easily by graphic means or is not self-evident or understood and that is considered to be pertinent to a correct interpretation of the particular manuscript.

The compilation report ordinarily will include two sections, the compilation report and the photogrammetric office review.

### *7261 Preparation of Compilation Report*

The compilation report shall be arranged in accordance with side headings 31 to 50 inclusive, as listed and discussed in subsequent paragraphs. The number and side heading of any inapplicable item shall be tabulated with the comment "inapplicable," and where there are consecutive inapplicable items these shall be grouped together, as for example No. 32 through 34 "inapplicable." Because of the wide range of subjects possible in a compilation report, many headings must be included in this outline. However, the photogrammetrist shall understand that he is under no obligation to write something under each heading (see 72). Only pertinent information shall be included in the compilation report. Generalities shall be avoided.

The compilation report shall be simply headed "Compilation Report, T-0000." The first page of the report shall be numbered the next consecutive number after the last numbered page of Form M-2388-12. A short unnumbered paragraph may be used as an introduction, where necessary, to include references to the photogrammetric plot report or field inspection report when either or both of these are not bound with the particular Descriptive Report. In no case should information to be included in item 1 (see 7232) be given.

It will be assumed that map manuscripts have been drafted in accordance with project instructions, this manual, and any subsequent amendments, and the compilation report shall not include statements regarding inks, weight of lines, and such details with reference to the mean high-water line, mean low-water line, or other features on the manuscript unless unspecified methods or materials have been employed.

31 *Delineation*—State whether graphic or instrument methods were used. Where both methods were used, state the features compiled on the instrument and those compiled separately. Describe briefly any unusual method of compilation.

Discuss specifically any areas where photographs and/or the field inspection were unsatisfactory or incomplete.

Identify specifically any areas of the manuscript that are incomplete. If field edit is to follow compilation, information shown on the discrepancy overlay need not be listed in the report.

32 *Control*—Discuss the adequacy of horizontal control with reference to (a) identification, and (b) density and placement. Where the compilation was on a stereoscopic instrument, discuss the adequacy of vertical control from both viewpoints.

33 *Supplemental data*—List each survey, map, or plan of this Bureau or of other organizations, used to supplement the photographs and identify the information taken from each. If special methods of reduction or correlation were used, describe these.

34 *Contours and drainage*—For stereoscopic instrument contouring, discuss the quality of the photographs and diapositives. Discuss any particular difficulties encountered in contouring. Identify areas of questionable work and include any information necessary for the field editor which is not on the discrepancy overlay.

For the compilation of planetable contouring on aerial photographs, discuss any particular difficulties encountered in compiling the contours. Discuss any changes or adjustments made to the field contouring other than those required by relief displacements on the photographs. Identify any areas requiring particular attention during field edit as regards either topographic expression or accuracy.

35 *Shoreline and alongshore details*—Under this heading include any pertinent information relative to the mean high-water line, the low-water line, shoal lines, the fore-shore, piers, wharves, retaining walls, and buildings and other structures adjacent to the shore.

State whether the shoreline inspection was adequate, and if it was inadequate, state how this affects the completeness or accuracy of the map manuscript.

State whether the low-water and shoal lines were based on data furnished by the field party or were delineated from office interpretation of the photographs.

36 *Offshore details*—Discuss any unusual problems encountered in compiling details offshore from the high-water line. Offshore details to be completed by the hydrographic party are reported in paragraph 49 and should not be repeated here.

37 *Landmarks and aids*—Under this heading include any pertinent information on landmarks for charts, interior landmarks, fixed aids to navigation, floating aids to navigation, and aeronautical aids. Do not repeat any information submitted on Form 567. Leave a blank space of at least 2 inches for a Washington Office entry.

If the positions of any aids to navigation were based on sextant cuts or similar data furnished by the field inspection party, explain any unusual methods of compilation.

38 *Control for future surveys*—Include here any pertinent information relative to recoverable topographic stations and photo-hydro control.

State whether forms 524 have been submitted for recoverable topographic stations, list the number of the forms applicable to this map, and the date of transmittal of the forms. If the number of forms submitted do not agree with the list given in paragraph 11 of the Field Inspection Report, explain in detail. Identify any recoverable topographic stations whose positions were determined on stereoscopic instruments.

State whether the list of recoverable topographic stations and photo-hydro stations, with descriptions of the latter, have been prepared and included in paragraph 49.

39 *Junctions*—List the adjoining manuscripts and/or surveys or maps and state if the junctions are in agreement. State the disposition of those not in agreement.

40 *Horizontal and vertical accuracy*—Identify any areas of the map manuscript that are considered subnormal in either horizontal or vertical accuracy. If these have been discussed in previous paragraphs, a reference to those paragraphs will be adequate. If, for any reason, the manuscript as a whole is believed to be subnormal in either horizontal or vertical accuracy, state that fact and discuss its probable position accuracy.

If the accuracy of the entire map manuscript is believed to comply with the National Standards of Accuracy and with the project instructions, no statement is required.

41 through 45—For use in numbering additional items discussed in the Descriptive Report for which no specific provision is made here

46 *Comparison with existing maps*—The map manuscript shall be compared with the latest topographic quadrangles of the area and with any planimetric maps of the Bureau. This comparison is made as a check on the adequacy of the new map manuscript to supersede the older maps

Identify each map with which the manuscript is compared, by name and number (if it has a number), scale, date of edition, and date of reprinting

The fact that this comparison has been made shall be stated but little discussion of differences is usually necessary. Where differences are found and you are certain the new map manuscript is correct, no statements about these differences are required, except as required below. Where differences cannot be reconciled, they shall be referred to field edit if they have not been disposed of by statements under previous headings of the compilation report

Small differences to be expected because of the time interval between the published map and the manuscript, shall not be listed or discussed. Large changes which may be of particular interest to chart compilers or to the Washington Office reviewer, should be mentioned. Offshore and alongshore features of importance to nautical charts that were on previous maps but are now non-existent shall be listed to show that they have not simply been overlooked

47 *Comparison with nautical charts*—The manuscript shall be compared with the largest scale nautical chart of the area. State the chart number, scale, date of publication, and the last correction date

This comparison with the nautical charts serves two purposes, (1) to determine whether the manuscript is complete and adequate to supersede the land details on the chart, so that inadequate data can be referred to the field edit, or mentioned in the compilation report, and (2) to identify and list specifically important new features which should be immediately applied to the chart. Information to be included under this heading is discussed in more detail in subsequent paragraphs

(a) The maps listed in paragraph 46 are often the sources of most of the topography on the nautical chart. Where a comparison shows that this is so, state this and state that the same differences are to be found between the nautical chart and the map manuscript as were mentioned in paragraph 46—do not repeat this information

(b) List any topographic information on the map manuscript that is of sufficient importance to warrant immediate application to the chart. List here, or indicate on a chart section, any major features on the map manuscript that have not yet been charted, such as large piers and large changes in shoreline features, particularly if the latter occur at inlets or near channels important to navigation. Such important but uncharted features occur only occasionally, but when they do occur, it is important that they be emphasized in this manner. As soon as the Descriptive Report is received in the Washington Office, it is referred to the Nautical Chart Branch with a specific reference to these features, otherwise, important features of this nature would probably not be charted until after the map has been reviewed and registered, which may be several months later. If there are no such features to report, write the word "None" under the statement, "*Items to be Applied to Nautical Charts Immediately*"

(c) List, or indicate on a chart section, the *topographic details above the plane of mean high water that are not shown on this manuscript, but which are believed to exist and which should be carried forward on the chart*. If there are no such features to report—



which is generally the case—write the word “None” under the statement, “*Items to be Carried Forward*”

(d) Discuss unusual shoreline changes, such as are frequently found on sandy points or at sandy inlets, which are sufficiently large to be of interest to the chart compiler or to persons interested in beach erosion or coastal changes. Be sure that these are actual changes and not due to the inaccuracy of previous surveys. If the shoreline changes or cultural changes are small and normal for the period of time involved, this paragraph should be omitted entirely. Small changes that are to be expected when a later and usually more detailed survey is made need not be listed or discussed in the report omit

(A survey was needed in the area, (otherwise it would not have been made) Therefore the new manuscript is expected to show additional features and to show the shoreline and other features in more detail than the older surveys, therefore, differences between the chart and the manuscript generally need not be listed or discussed except as required in (a) to (d) above.)

48 *Geographic name list*—An alphabetical list, on a separate page or pages, of all geographic names lettered on the manuscript shall be included in every copy of the compilation report

Where the alphabetical list contains geographic names that were not reported in a special geographic names report, the Descriptive Report should contain all the available information relative to them

The list may be arranged in two columns, if there are many names, however, there shall be a blank space of at least 1½ inches to the right of each column for Washington Office entries

49 *Notes for the hydrographer*—This section of the compilation report shall be on separate pages from any other section of the report and shall include

(a) A tabulation of all photo-hydro stations and recoverable topographic stations shown on the manuscript, with the reference numbers and descriptions of photo-hydro stations and the names of the topographic stations. Topographic station descriptions need not be included since copies of Form 524 are furnished the hydrographer

(b) A chart section or sections diagramming details between the planes of mean high water and mean low water or mean lower-low water left to be proved, disproved, or located in position by the hydrographer

(c) Pertinent information which will be useful to the hydrographer in using the copies of the map in hydrographic surveys

Notes for the hydrographer shall be prepared in duplicate and bound with the compilation report, but must be on separate unnumbered pages and must be entitled “Notes for the Hydrographer,” as it may be extracted from the Descriptive Report and forwarded to the hydrographer in lieu of the entire report

*Notes for the reviewer*—Occasionally it will be desirable to include in the compilation report information for the use of the Washington Office Review which is not of sufficient importance to become a part of the permanent record. In such cases this information shall be placed on unnumbered pages separate from any other section of the report and entitled “Notes to the Reviewer.” These notes will be extracted after completion of the Washington Office Review. Notes for the reviewer are not required for each map and should seldom be needed. They shall not include self-evident information, or any information apparent on the manuscript or included in the text of the Descriptive Report

*7262 Photogrammetric Office Review, Form T-2*

Form T-2, Photogrammetric Office Review, shall be completed in accordance with the instructions in this manual (see 5811) The completed form and the accompanying remarks are the photogrammetric office review report—no other report is required

The form shall be completed in duplicate, identified as side heading 50, and bound in the two copies of the Descriptive Report at the end of the compilation report

**727 FIELD EDIT REPORT**

A field-edit report shall be prepared for each map field-edited Each report shall be prepared in duplicate and shall accompany the map manuscript when it is forwarded to the photogrammetric office The tabulation of accuracy tests forwarded separately to the Washington Office will be transmitted to the photogrammetric office after examination and for inclusion in the Descriptive Report immediately following the field-edit report

Any information included in the Data Record, such as the dates of the field-edit surveys or by whom the surveys were made, will not be repeated in this report The information to be included in this report will be in accordance with the following side headings

51 *Methods*—Describe in general the methods used in field-editing the manuscript State whether deletions, additions, and corrections to the manuscript have been noted on the field-edit sheet or on the photographs

State whether a legend describing the symbols and the colored inks used is shown on the field-edit sheet or on one of the photographs used during the field edit

List the number of field-edit sheets and photographs on which field-edit information has been shown

52 *Adequacy of compilation*—Describe the completeness and adequacy of the map compilation Take into consideration the extent of the field inspection

53 *Map accuracy*—Discuss the accuracy of the map compilation as to horizontal position, if it is inadequate, give the particulars Discuss the accuracy of the contouring and if inadequate, explain the deficiencies Include the location and size of any areas that had to be contoured during field edit, either because they were found to be incorrect or were omitted during stereoscopic instrument compilation

List the accuracy tests made on the manuscript and give a brief summary of the results with reference to the tabulated summaries

Each accuracy test shall be tabulated in accordance with the field instructions and forwarded in duplicate to the Washington Office

54 *Recommendations*—Recommendations for improving the quality or adequacy of similar maps are desired from those making field-edit surveys These recommendations are not to be personal criticisms Recommendations may also be made for the improvement of the legibility of the manuscript copy for field edit

55 *Examination of proof copy*—The name and address of one or more residents in the area who are intimately acquainted with it, who are able to read a map with assurance, and who will agree to examine a proof copy of the map for possible errors will be included under this heading

Any corrections to geographic names or names of features or any additional information on names shall be included under this heading

Any additional items will be numbered consecutively, from 56 to 60 If there are additional comments and information to be added to any previously numbered side heading in any report, include the information under one of these numbers and refer to the original side heading number in the previous report

## CHAPTER 8

### WASHINGTON OFFICE REVIEW AND COMPLETION

#### 81 GENERAL STATEMENT

Chapter 8 contains instructions for the review and completion of map manuscripts, for the functions of the Division of Photogrammetry with regard to the publication of maps from the manuscripts, and for the disposal of photographs and records in the Washington Office. This chapter applies particularly to the activities of the Division of Photogrammetry in the Washington Office but is of general interest to all Bureau personnel engaged in photogrammetric mapping and to the personnel of other Divisions of the Bureau who use the map manuscripts and associated records.

Coastal topography is an essential part of a nautical chart and photogrammetric mapping by the Bureau is primarily to furnish topography for that purpose, as stated in 15. Consequently, the procedures in nearly all phases of map preparation, particularly those in the Washington Office, are correlated with the nautical chart production of the Bureau and differ from those followed where the topographic map is the sole objective. The prime consideration in the Washington Office is to ensure that the manuscript is adequate for charting purposes and that all important data are reported immediately to the Nautical Chart Branch. Field survey personnel, compilers, and Washington Office reviewers are especially trained to understand nautical chart requirements.

#### 811 OUTLINE OF PROCEDURES

The procedures normally followed in the Washington Office in completing a typical map manuscript are outlined chronologically, the records associated with such a manuscript are listed in table 7 1 and are described in Section 71.

- (a) Manuscript received date recorded on Form T-1, transmitting letter received
- (b) Film negative and prints made (8234)
- (c) Reported to Nautical Chart Branch (8234)
- (d) Office inspection (83)
- (e) Forwarded for field edit (83)<sup>1</sup>
- (f) Accuracy tests received accepted for and routed to Review Section (8236)<sup>1</sup>
- (g) Manuscript received after application of field-edit corrections accepted for, and routed to Review Section (8235)<sup>1</sup>
- (h) Manuscript appraised for new nautical chart data, pertinent facts reported to Nautical Chart Branch (842)
- (i) Review and preparation of drafting overlay (84)
- (j) Registration of manuscript copy of topographic maps (8237 and 8473)
- (k) Addition of hydrographic data (846)<sup>2</sup>
- (l) Smooth drafting, edit and reproduction (85)
- (m) Proof edit (857)
- (n) Registry in archives (8237 and 8473)
- (o) Disposal of original film negative ( (b) above) (8238)
- (p) Registry of color print of topographic maps (8473)
- (q) Assembly of project report after project has been completed (86)
- (r) Disposal of records after project has been completed (86)

<sup>1</sup> Not generally applicable to shoreline surveys  
Topographic maps only

**82 ROUTING AND DISPOSAL OF PHOTOGRAMMETRIC RECORDS****821 PRELIMINARY**

The Division of Photogrammetry is essentially a service division which takes and purchases aerial photographs, and produces surveys and maps for the use of other divisions of the Bureau—particularly for the use of the Division of Charts in constructing and maintaining nautical and aeronautical charts. Photographs are taken as needed for photogrammetric mapping, and for chart maintenance, as described in 2. Photographs are also purchased from other agencies, particularly for use in constructing and maintaining aeronautical charts.

This section contains a brief description of the files of the Division of Photogrammetry, and detailed instructions for routing and filing the various photogrammetric data.

Aerial film is filed in the Division as long as it is needed for Bureau use, after which it is forwarded to the National Archives for permanent storage.

Map manuscripts and the associated records are retained in the files of the Division of Photogrammetry pending review, publication, or registration, after which a copy of each map and the original Descriptive Report, and certain of the survey records, are transferred to the Bureau Archives, while others are retained in the Division of Photogrammetry on a permanent or semipermanent basis, as stated in 8238.

**822 DIVISION FILES****8221 *Aerial Film***

Single-lens negatives are filed in rolls and are cataloged by the camera used, negative number, date, and roll number. Nine-lens film negatives are filed in envelopes, each containing about 10 negatives, and are cataloged by negative number and date. The following data are recorded for each aerial negative taken by the Bureau: The type of camera and focal length of lens, camera code letter and year, date and time, scale, project number, state or territory, altitude at which taken, and quality of the film.

**8222 *Photograph Files***

Two files of photographic prints are maintained—one of office photographs and one of field-inspection photographs. Field-inspection photographs containing original field notes are essentially original records pertaining to the maps compiled from them, and they are retained more or less permanently in the Division files. Office photographs are destroyed after the maps compiled from them have been reviewed, published, and registered, and when they are no longer needed for map compilation or chart maintenance, the files being cleaned out periodically to conserve space.

Nine-lens photographs are filed by numbers. Single-lens photographs taken by the Bureau are filed by camera letter, year, and exposure number. Single-lens photographs purchased from other agencies are grouped according to areas and filed by accession numbers.

**8223 *Map Manuscripts and Field edit Sheets***

Map manuscripts and field-edit sheets are filed in jackets by map numbers, as for example, T-8530. Supplemental maps or plans used in compilation that apply solely to one map are filed in the same jacket. After review, a cloth-backed lithographic copy of each

map and its Descriptive Report are registered and permanently filed in the Bureau Archives. After this has been done the map manuscript and field-edit sheet are still retained in the Division of Photogrammetry files, but all other items are removed from the jacket and transferred to the Archives or destroyed (see 8238)

### *8224 Descriptive Reports*

Original and duplicate Descriptive Reports are filed in envelope jackets by map numbers, as T-8530, and correspondence relative to the specific map, reports on accuracy tests, etc., are filed in the same jacket.

When a map is registered, the original Descriptive Report is transferred to the Bureau Archives, the duplicate copy is retained in the Division file until it is no longer needed, after which it is destroyed, together with other miscellaneous records collected during compilation that are no longer of use. Descriptive Report jackets are generally not disposed of until after all field work, including hydrographic surveys, has been completed in the project area and the project report has been written (see 8238 and 86)

### *8225 Station Identification Cards and Form 524 Descriptions*

Station identification cards (see fig 4 2) are filed by map numbers, as T-8530. Under each map number the file contains one card on which is listed, by station name, each station identification card filed under that map number. This file is permanent.

All descriptions of recoverable topographic stations, Form 524, whether submitted with planetable surveys, hydrographic surveys, or photogrammetric surveys, are filed in the Division of Photogrammetry by map numbers. Under each map number the file contains one card on which is listed, by station name, each Form 524 description filed under that map number. Recovery notes (also on Form 524) for topographic stations are filed with the original descriptions. This file is permanent.

### *8226 Project File*

A project file is maintained, arranged by map project numbers, in which are filed all the various data in each project that apply to more than one map which, consequently, cannot be filed with an individual manuscript or Descriptive Report. These data include

- (a) Project plans and layouts (153)
- (b) Field-inspection reports applicable to more than one map (724)
- (c) Season's reports (718)
- (d) Project reports (718)
- (e) Boundary and land-line reports (714)
- (f) Accuracy tests
- (g) Records of horizontal control of less than third-order accuracy (71)
- (h) Miscellaneous maps etc.

All items in the project file are cataloged as to type, year, and Chief of Party. In this catalog are also listed by projects all field-inspection photographs containing field notes, with a notation of the number of duplicate prints where notes were made on more than one print of any photograph.

After a project has been completed, miscellaneous items collected during compilation and no longer needed are transferred elsewhere in the Bureau, or are destroyed. All reports are bound in one project report, which is transferred to the Bureau Archives, as are also the control records (8238)

### *8227 Indexes of Photographs and Maps*

All aerial photographs taken by the Bureau, and all photogrammetric maps are indexed on specially prepared quadrangle indexes. In the United States, these indexes are arranged in 1° quadrangles, in Alaska each photograph index includes 1° latitude by 2° longitude but the map indexes are of irregular size because of the rapid convergence of the meridians, irregularity of the coast line, and the many off-lying islands. Copies of the indexes are distributed by the Division of Photogrammetry. A set of these indexes is maintained in the Nautical Chart Branch and in each District Office for reference use, these special sets of indexes are maintained concurrently with the originals in the Division of Photogrammetry.

### *8228 Airport Surveys*

Aerial photographs used in airport surveys are filed as stated in 8222. All other data, the manuscripts, and the survey records are kept in jackets filed under the name of the airport, records of revision surveys being filed with the original data. Airport survey manuscripts and records are filed more or less permanently in the Division of Photogrammetry, the jackets being inspected periodically and miscellaneous useless and superseded material being disposed of.

### **823 PHOTOGAMMETRIC RECORDS**

Under this heading are outlined the steps taken in completing and filing photogrammetric records and in distributing the data resulting from the photogrammetric surveys.

Data collected during the photogrammetric field surveys and during compilation that are of immediate importance to nautical or aeronautical charts must be segregated and routed to the Nautical Chart and Aeronautical Chart Branches immediately upon receipt in the Office—not after completion of the map.

The distribution of records after their receipt in the Washington Office is important and is outlined here in detail. The transfers of all records between the Washington Office and field parties are receipted for on Transmitting Letters, Form 413a. All records loaned to various sections or groups in the Washington Office, are accounted for on convenient charge slips. This is particularly important in photogrammetric mapping because of the numerous items associated with each map and the necessity of avoiding the loss of vital data, for example, an identification card for a control station in Alaska that could be replaced only with great difficulty and at considerable cost.

### *8231 Aerial Negative Inspection and Appraisal*

Aerial negatives are forwarded to the Washington Office by the Photographic Mission immediately after one or a few rolls have been exposed. Each roll of film is accompanied by a flight record stating the camera used, the area covered, the date and time of photography, altitude, weather conditions, and information to assist in developing the film.

Film is developed immediately upon receipt and is then inspected for adequacy as to coverage, end lap, side lap, and clarity of photographic detail, and the Photographic Mission is then notified by letter of any deficiencies and is notified by telegraph or radio of any required reflights.

The nine-lens negatives themselves are inspected. Contact prints of single-lens photography are usually made and inspected, although the film itself is referred to where there is any question as to the quality of the photography. Shingle mosaics are usually made of

single-lens photographs during the inspection, or soon afterward, and are used in planning and future operations

At the time new photography is inspected for adequacy, or immediately afterward, it is also inspected to see if it contains any new information of importance to nautical or aeronautical charts. This is done by comparing the photographs with the latest edition of the largest scale chart of the area, and noting new information, such as uncharted large piers, important changes in coastline, new airports, and major cultural changes of importance. Features of importance to nautical or aeronautical charts are reported to the Nautical or Aeronautical Chart Branch by memorandum giving the date of the photography and identifying the pertinent exposures. New photographs showing airports are reported to the Aeronautical Chart Branch.

Following the inspection of new photography, all single-lens film is titled as illustrated in figure 1 19 and described in 156

### 8232 *Field Survey Records*

Most photogrammetric field-survey records are forwarded directly to a photogrammetric field office and do not reach the Washington Office until the map manuscript has been completed. However, there are certain exceptions to this, as noted in table 7 1.

Geodetic records (horizontal and vertical control surveys of third-order or higher accuracy), are forwarded directly to the Division of Geodesy in the Washington Office and are registered in the Bureau Archives. Landmark reports, coast pilot reports, and letters or reports relating to dangers to navigation, or immediate corrections to nautical charts, are accepted for and transmitted to the Nautical Chart Branch and the Coast Pilot Section. Landmarks for aeronautical charts are transmitted to the Aeronautical Chart Branch. Geographic name reports and the accompanying name sheets are transmitted to the Geographic Names Section, where the reports are examined and evaluated and standard name sheets are prepared for use of the photogrammetric office compiling the maps. When boundary reports are forwarded directly to the Washington Office, as mentioned in 714, photostat copies of the maps accompanying the report are made immediately and one copy of the report, together with one set of the maps, is forwarded to the photogrammetric office for use in compilation.

The project instructions for a photogrammetric project in the United States occasionally will specify that all photogrammetric field-survey records pertaining to a certain subdivision of the project shall be forwarded directly to the Washington Office for appraisal. In such case, when the records are received in Washington, they are immediately examined to see whether they are adequate, complete, and in conformity with the project and general instructions, and the Chief of the field party is notified of any deficiencies, after which the records are forwarded to the photogrammetric office where the maps are to be compiled.

All field records of practically all Alaska projects are transmitted directly to the Washington Office prior to map compilation. These records are examined in detail and appraised with reference to the next season's operations in Alaska, and with reference to map compilation. Project instructions for compilation, or amendments to existing instructions for compilation, are then prepared and the records are transmitted to a photogrammetric office. The photogrammetric compilation of Alaska maps is often subdivided—some phases of compilation being done in the Washington Office and some in the field photogrammetric office, and the records are divided accordingly.

Season's reports, and project reports (covering more than one map), whether received before or after compilation, are immediately examined for information of importance to nau-

tical or aeronautical charts and, if containing such information, they are routed to the Nautical or Aeronautical Chart Branches. These reports are also routed to various sections in the Division of Photogrammetry and to other divisions if they contain information of interest to such divisions, as for example, the Division of Coastal Surveys or the Division of Geodesy.

### *8233 Field-inspection Photographs*

Field-inspection photographs received in the Washington Office prior to map compilation, as mentioned in **8232**, are immediately examined for important nautical and aeronautical chart data and the pertinent photographs are reported to the Nautical and Aeronautical Chart Branches.

### *8234 Map Manuscripts and Descriptive Reports*

A film negative at manuscript scale and several contact prints are made of each new manuscript as soon as it is received in the Washington Office. One print of the manuscript is then forwarded to the Nautical Chart Branch where it is diagramed in pencil on the chart standards and is filed for possible use on nautical charts prior to review and completion. *After a manuscript has once been reported to the Nautical Chart Branch, all subsequent corrections or additions shall be made in red ink so that they will be apparent to the chart compiler. These corrections and additions include field-edit corrections applied in photogrammetric offices and changes made in the manuscript during the Washington Office review.*

One print of each new manuscript is also forwarded to the Geographic Branch and a print of each new manuscript showing an airport is forwarded to the Aeronautical Chart Branch. The manuscript and accompanying records, as listed in **715**, are then forwarded to the Review Section for office inspection (**83**).

When a map manuscript is applied to any nautical chart, the chart number and date of application, together with a statement as to whether the manuscript was applied to the chart in whole or in part, are recorded on Form M2168-1 and inserted in the Descriptive Report by the Nautical Chart Branch. This record is essential to certain procedures mentioned in **84**.

### *8235 Field-edit Records*

After completion of the office inspection, copies of topographic and planimetric map manuscripts and associated records listed in **715**, are forwarded to the field-edit party. The preparation of data for field edit is the responsibility of the Review Section. After field edit the map manuscript is forwarded directly to the photogrammetric office for application of field-edit corrections. (See **8234**.)

Topographic and planimetric manuscripts received after application of field-edit corrections, are forwarded to the Review Section, where they are examined for any corrections or changes of immediate importance to nautical or aeronautical charts which are reported by the Review Section to the Nautical or Aeronautical Chart Branches.

### *8236 Accuracy Tests*

When received in the Washington Office, horizontal and vertical accuracy tests (**715**) are transmitted to the Review Section for analysis. When the accuracy of a map, or any portion thereof, is unsatisfactory, instructions are prepared for the field-edit party or photogrammetric office to make the necessary revisions.



All accuracy tests are summarized by map numbers, each summary is forwarded to the photogrammetric office where the field-edit corrections are to be applied and is there inserted in the field-edit report

### *8237 Registration in Bureau Archives*

The review, smooth drafting, proof edit, and the duties of the Division of Photogrammetry in connection with the publication of maps are described in 84 and 85. After a map has been reviewed and the map and the review have been approved in the Division of Photogrammetry, the map is officially registered. Registration in the Archives consists essentially of preparing a cloth-mounted printed copy of the map and forwarding this and the Descriptive Report to the Library where the map copy and the report are cataloged and permanently filed. They are later forwarded to the Division of Coastal Surveys and the Division of Charts for approval and signature in the Descriptive Report. Registered surveys and maps are kept in a fireproof vault which contains the smooth copies of all hydrographic surveys, all planetable surveys, and the registered copies of all photogrammetric maps made by the Bureau. The accompanying Descriptive Reports are also filed in the Archives.

The registered copy (permanent file copy) of each planimetric map and shoreline survey (15) consists of a lithographic print in black on the best quality cloth-mounted paper. This print is made immediately after all proof-edit corrections have been applied to the reproduction negatives or printing plates.

Two prints of each topographic map published as a quadrangle are registered. The original manuscript, after Washington Office review, is reproduced at the manuscript scale and a lithographic print in black is made on cloth-mounted paper. This print and the Descriptive Report are routed for signature, cataloged and filed in the Archives as stated above, prior to smooth drafting. After publication, one printed copy of the map in colors is mounted on cloth and also filed in the vault, with the manuscript copy described in this paragraph.

It is the responsibility of the Review Section to keep detailed and accurate records of the progress of each map manuscript from its receipt in the Washington Office until its final registration and publication.

### *8238 Project Completion*

After all maps in a project have been registered and all planimetric maps and topographic maps have been published, the Division of Photogrammetry files for that project are renovated, records no longer needed are discarded and those of permanent value are placed in permanent files, as follows:

(a) Metal-mounted office photographs are dismantled; the photographs are destroyed and the metal reused. Field photographs are re-examined and those containing field notes are placed in a semi-permanent file in the Division of Photogrammetry. All other photographic prints in good condition are placed in a distribution file.

(b) Control survey records (for horizontal and vertical control surveys of less than third-order accuracy), are transferred to the Archives if of probable future value; otherwise they are discarded.

(c) Jackets containing the original manuscripts and field-edit sheets are transferred to a more or less permanent file in the Division of Photogrammetry. The film negative (8234) and miscellaneous material collected in the jacket during work on the project are discarded with the exception that plans or maps of value to the Archives map file or Nautical Chart Branch are forwarded thereto.

(d) Carbon copies of Descriptive Reports, including extra copies of the notes to the hydrographer and descriptions of photo-hydro stations, are held in the file until hydrography in the project area has been completed after which they are discarded.

(e) All special reports on the project, such as boundary reports, land-line reports, season's reports, project reports, etc., including field-inspection reports applicable to more than one map, are bound together, with one copy of the project instructions and any amendments thereto, to form one project report which is transmitted to the Archives. An exception is the Geographic Name Report which is retained in the files of the Geographic Names Section. (See also 86)

(f) Station identification cards, and Form 524, descriptions and recovery notes of recoverable topographic stations, are retained in a permanent file in the Division of Photogrammetry — No —

(g) The correspondence files relative to the project are cleaned out and all routine letters are discarded. Letters of probable future importance, together with a few copies of project instructions, and one or two sets of project indexes, are retained more or less permanently in the Division of Photogrammetry

### 83 OFFICE INSPECTION

Each new map manuscript is inspected immediately upon receipt in the Washington Office, or if compiled in the Washington Office, the manuscript is inspected immediately upon completion

A general examination of the manuscript and Descriptive Report is first made by the Technical Assistant to the Chief of Division, or by the Chief of the Review Section, to

(a) Detect any lack of conformity with general and project instructions

(b) Study any unusual circumstances encountered in the field or office which require amendments to the project instructions

(c) Prepare brief informal instructions to the reviewer regarding items that need special attention prior to field edit. *Check with Geographic Names Section as to items they'd like to have checked*

(d) Note any information of immediate importance to nautical or aeronautical charts

*Check discrepancy overlay submitted by compilation office.*

Following this general examination, field parties or photogrammetric offices are informed by letter of any inadequacies, supplemental instructions are prepared, if needed special instructions to the reviewer are attached to the Descriptive Report, and items of immediate importance to nautical or aeronautical charts are reported thereto by routing the Descriptive Report or by means of an office memorandum

Maps that are to be field-edited are routed to the Review Section for inspection by a reviewer and are routed to the Geographic Names Section for the geographic names to be checked. Those not to be field-edited are filed awaiting Washington Office review, as described in 84

The inspection in the Review Section is actually the first part of the Washington Office review of the map and the work done at this time is not repeated later. The inspection is limited to a day or two, but includes a rather detailed examination of the manuscript, the Descriptive Report including the field inspection report, the photographs, and the discrepancy overlay prepared in the compilation office, all efforts being devoted to the discovery of inadequacies that must be taken care of by the field editor

A discrepancy print is prepared on a photographic copy of the manuscript by carrying forward the notes made on the discrepancy overlay and by adding such notes as the reviewer may deem necessary. This discrepancy print serves as special or supplemental instructions to the field editor

Horizontal and vertical accuracy tests required for a particular map are noted on the discrepancy print which indicates in general the parts of the map to be tested, although some discretion in the extent and exact placement of accuracy tests is left to the field editor

One reviewer ordinarily office-inspects and subsequently reviews an entire project or a practical subdivision thereof. This enables him to correlate and review efficiently a group of

*(f) Check all and against latest light and information.*

maps by becoming entirely familiar with the project instructions and the particular geographic and topographic aspects of the area

All special instructions for the field edit of a specific map are generally noted on the discrepancy print, however, where conditions are encountered which require radical changes in the usual field-edit methods, or extensive and costly surveys, special written instructions are prepared

The Review Section is responsible for scheduling the office inspection and preparation of field-edit copy so that field-edit parties can be supplied with an adequate number of maps to be field-edited. The data to be forwarded for the field edit of a map are listed in 715

## 84 WASHINGTON OFFICE REVIEW

### 841 GENERAL STATEMENT

The Washington Office review comprises a final examination of the map manuscript, and all related records, to ensure the adequacy of the manuscript and its accompanying Descriptive Report for (a) Nautical chart construction and maintenance, (b) Aeronautical chart construction and maintenance, (c) Publication as a topographic or planimetric map (with the exception of shoreline surveys which are not published—15)

The final review includes the preparation of the manuscript for smooth drafting so that all subsequent operations, including smooth drafting, verification of the drafting, proof edit, and publication can be completed solely with reference to the manuscript and the Descriptive Report and without further reference to the photographs and survey records

One reviewer, reviewing all the maps of a project, or of a large part of a project becomes familiar with the character and peculiarities of the project area, with the existing maps and charts of the area, and with the purpose of the project and all the instructions issued for it, and is able to review the maps in a minimum of time. The review includes a detailed examination and study of the map manuscript and report and an investigation of such phases of the work as the reviewer may deem necessary. The Washington Office review does not repeat what was done during the photogrammetric office review described in 58, although the reviewer may, and usually does, spot-check the photogrammetric office work for adequacy and thoroughness

The exact procedures followed in the Washington Office review vary from project to project, and even from map to map, but the review always includes the following

(a) A detailed examination and study of the manuscript and report to ensure their clarity and consistency with project and general instructions and with Bureau policy, and the investigation of any inadequacies indicated by this study

(b) A comparison of the manuscript with the field records, photographs, and supplemental plans to ensure that all have been properly used in compilation

(c) Comparison with prior registered topographic surveys by the Bureau *see 507*

(d) Comparison with topographic and planimetric maps published by other agencies as to the broad portrayal of the area, but generally omitting the detailed comparison made during the photogrammetric office review

(e) Comparison with contemporary hydrographic surveys

(f) Comparison with the largest scale nautical chart

(g) Correction of inadequacies discovered during the review

(h) Evaluation as to the map's conformity with the National Standards of Accuracy

(i) Preparation of the manuscript for smooth drafting which includes reference of the manuscript to the Geographic Names Section for the verification of geographic names

(j) Preparation of the review report

## 842 MAP MANUSCRIPT AND DESCRIPTIVE REPORT STUDY

Prior to beginning the actual review of the first manuscript in a project, the reviewer must have carefully examined the project instructions and published maps and charts of the area and be thoroughly familiar with them. The first part of the review then comprises a deliberate and objective reading of the manuscript and report to detect ambiguities, contradictions, and inadequacies. Ambiguous or contradictory statements in the Descriptive Report are clarified with ink notes in the margin of the report, each being initialed by the reviewer, or they are referenced to an explanation made in the review report. Ambiguities and minor inadequacies of the manuscript are clarified by deletions, or by corrections or additions in red (8234). Major inadequacies are investigated in as much detail as may be required. Notes are kept by the reviewer for preparation of the review report. The record of items examined during office inspection is consulted so that work done at that time is not repeated.

The reviewer examines the field-edit data for information of immediate importance to nautical or aeronautical charts and reports any such data to the Nautical Chart Branch or the Aeronautical Chart Branch.

## 843 CARTOGRAPHIC COMPARISON

Most photogrammetric surveys of the Bureau along the Atlantic and Gulf Coasts comprise resurveys of changeable areas, and the comparison of the new manuscript with existing maps and charts is necessary to ensure that the new map is complete and adequate to supersede the prior surveys.

*8431 Comparison with Registered Topographic Surveys*

Each prior planetable or photogrammetric survey of the same area made by the Bureau, is borrowed from the Archives and compared in detail with the new manuscript. These prior surveys are listed by map number, date, and scale in the review report, and a specific statement is made in the report as to whether each is unqualifiedly superseded for nautical charting by the new map, or whether certain specific details on the older surveys are not covered by the new map and must be carried forward on the nautical charts from the prior surveys. This exact procedure is followed in all cases, so that the nautical chart compiler can apply the new manuscript to the charts without reference to prior surveys, except where specifically indicated in the review report. Differences between the prior surveys and the new manuscript that may be expected due to the elapsed time between the surveys, the difference in scale, etc., are not discussed or listed in the review report, but large and unusual changes are mentioned.

*8432 Comparison with Maps of Other Agencies*

The purpose and scope of the comparison with topographic or planimetric maps published by other agencies, made during the photogrammetric office and Washington Office review, are described in 7261 and 841. The maps with which the new manuscript was compared are listed in the review report. Minor differences, particularly those to be expected because of the difference in time or scale, are neither listed nor discussed, but unusual changes, and particularly major differences between the new manuscript and published maps due to interpretation, are mentioned in the review report.

8433 *Comparison with Hydrographic Surveys*

A contemporary hydrographic survey is one which depended on the photogrammetric map for hydrographic control and/or shoreline details The photogrammetric manuscript is always compared with contemporary hydrographic surveys, it usually is not compared with prior hydrographic surveys

A photogrammetric survey of the coastline and the contemporary hydrographic survey are essentially complementary parts of a combined operation, the purpose of which is to survey the shore and the adjacent waters for nautical charting The two surveys complement each other and can never be treated as separate entities, even though each may have been done by a different Chief of Party at a somewhat different date The planning and scheduling of photogrammetric and hydrographic surveys are discussed in 9 Generally, the photogrammetric survey precedes the hydrographic survey, and shoreline and hydrographic control points are transferred from the photogrammetric manuscript to the hydrographic boat sheet prior to sounding However, this procedure is not always followed and in some instances the hydrographic survey may be completed before the photogrammetric shoreline is available In such case a comparison of the two surveys may not be possible until the Washington Office review

Features seaward from the high-water line, including the low-water line, the character of the foreshore, rocks and obstructions bare at different stages of the tide, aids to navigation, coast pilot notes, etc., are the mutual responsibility of both the photogrammetric survey and the hydrographic survey These features are sometimes located during the photogrammetric and sometimes during the hydrographic survey, depending on field conditions, the scheduling of the surveys, and other factors—the purpose being to secure all the necessary information as economically as possible—thus the term “combined operations”

The hydrographic smooth sheet and the photogrammetric manuscript, after the Washington Office review of each has been completed, together must contain the locations of all the alongshore features, the two surveys need not duplicate each other, and should not do so, but they must not disagree in the configuration or positions of any features (see also 7827 Hydrographic Manual)

The comparison of the photogrammetric manuscript and hydrographic smooth sheet must ensure that

(a) The delineation of the low-water line by the combined surveys is complete and that discrepancies are eliminated A low-water line on the hydrographic smooth sheet based on zero soundings is generally preferable to one located photogrammetrically, although this is not an invariable rule In some instances the low-water line compiled from photographs taken at mean low water or mean lower-low water, may be preferable to that delineated from a relatively few zero soundings Sections of low-water line on the photogrammetric manuscript that are disproved by the hydrographic survey, are deleted from the photogrammetric manuscript [Low-water line is generally not transferred<sup>2</sup> from the hydrographic smooth sheet to the photogrammetric manuscript during review though this is not an invariable rule] If most of the low water line has been delineated on a photogrammetric manuscript, it may be desirable to complete it by transfer of the remainder from the hydrographic sheet

(b) The mean high-water line and soundings are in agreement Along steep shores slight errors in position of either the mean high water line or the inshore soundings, may result in the obvious discrepancy where soundings plot on land Such discrepancies must, of course be eliminated A quick investigation of the records will usually disclose the cause of the discrepancy [Neither survey can be accepted as necessarily correct, the error may be in the field interpretation of the high-water line on the photographs or in the sextant position fixing the soundings]

(c) Rocks and obstructions shown on both surveys agree in configuration horizontal position, and elevation above the sounding datum Minor discrepancies are rather frequent particularly if the surveys have not previously been compared with each other Discrepancies must be disposed of by examination of the records particularly the field-inspection photographs and the sounding records

(d) All alongshore rocks and obstructions are on the hydrographic smooth sheet. They need not be shown on the photogrammetric manuscript where they originate with the hydrographic survey—generally such features should not be transferred to the photogrammetric manuscript during review (see 846)

(e) The photogrammetric manuscript and contemporary hydrographic smooth sheet jointly are compared with the nautical charts to insure completeness of the new surveys

The photogrammetric manuscript and the contemporary hydrographic smooth sheet are compared both in the hydrographic Review Section and the photogrammetric Review Section, without any scheduling as to which section takes up the work first. If the hydrographic review is made first, all pertinent information is then transferred from the photogrammetric manuscript to the hydrographic smooth sheet and discrepancies are disposed of in conference with the photogrammetric Review Section. [Where the hydrographic reviewer is certain that a discrepancy is due to error in the photogrammetric manuscript, he may accept the data recorded on the smooth sheet and call the discrepancy to the attention of the photogrammetric reviewer by a note inserted in the photogrammetric Descriptive Report.]

The principal responsibility of the photogrammetric reviewer is to isolate discrepancies and to correct the photogrammetric manuscript if that is necessary. He does not transfer details to, nor change, the hydrographic smooth sheet. [Discrepancies believed to be due to errors in the hydrographic smooth sheet are reported to the hydrographic Review Section.]

\* [Each contemporary hydrographic survey is listed in the photogrammetric review report by survey number, date, and scale, with the statement that the comparison was made and the surveys are in agreement.] If discrepancies remain, they are mentioned and explained. If the surveys are not in agreement because of changes made on the photogrammetric manuscript since the shoreline was applied to the hydrographic smooth sheet, that fact is reported to the hydrographic Review Section.

The photogrammetric manuscript is compared with prior hydrographic surveys only when there are no contemporary hydrographic surveys, and a comparison with the prior hydrographic surveys is required for interpretation and verification of the completeness of delineation of alongshore features shown on the photogrammetric manuscript, this is often desirable on rocky coastline but is rarely necessary for other types of coastline.

#### 8434 Comparison with Nautical Charts

The photogrammetric manuscript is compared with the most recent issue of the largest scale nautical chart, to ensure the completeness and adequacy of the manuscript for chart construction and maintenance. Part of this work will have been done under heading 8433.

The reviewer will occasionally find items of importance to nautical charts that have not been previously reported—he will report these immediately.

The chart with which the manuscript was compared is always listed in the review report by chart number and date of issue. Minor differences to be expected because of the elapsed time since prior surveys are not discussed in the review report, but major changes and items of particular interest to the chart compiler are mentioned.

A record made by the nautical chart compiler on Form M2168-1 and inserted at the back of the Descriptive Report (8234) shows whether the manuscript has been applied to the chart prior to review. All changes made to the manuscript during review are made in red ink (8234) and if any changes of consequence to nautical charts are made after the manuscript was applied to the charts, that fact is stated in the review report.

### 844 PREPARATION FOR SMOOTH DRAFTING

The manuscript is prepared by the reviewer in such manner that the smooth drafting, proof edit, and publication can be done without further reference to the photographs and survey records. This usually includes the clarification of poorly drawn or ambiguous symbols and notes on the manuscript, and the preparation of a drafting overlay, the latter comprising instructions to the draftsman.

A manuscript occasionally contains notes or minor features that are not to be shown on either the registered copy of the map (847) or on the published copy, and these must be removed. But there are some notes and features to be retained on the registered copy of a topographic map, but not on the published map (847), that must be indicated on the drafting overlay with the necessary instructions to the smooth draftsman. Map features that are not clear and legible must be clarified on the manuscript by redrafting, or explained on the drafting overlay.

The sole purpose of the drafting overlay is to guide the smooth draftsman and editor. It is for temporary use only and is so drawn. The overlay is made on tracing paper, tracing cloth, or Kodatrace, in colored pencil. It supplements the manuscript and contains information and instructions about any of the following details that are not complete on the manuscript, but it does not contain information that is self-evident on the manuscript.

- (a) Marginal Notes
- (b) Projection and grid lines, and figures
- (c) Control stations
- (d) Spot elevations and contours
- (e) The shoreline and offshore features
- (f) Drainage
- (g) Roads including the classification of roads
- (h) Boundaries and land lines
- (i) Other cultural features
- (j) Geographic names
- (k) Data to be omitted
- (l) Legends

Shoreline surveys must be treated somewhat differently during this phase of the review inasmuch as they are ordinarily smooth-drafted when compiled, with the exception of the names and notes which are roughly lettered. Shoreline surveys are generally not redrafted but occasionally parts of the survey must be clarified or otherwise retouched in the Drafting Section, and in the future all names and notes will be replaced by printed names and notes. The reviewer is responsible for appraising the shoreline survey as to adequacy, clarity, and appearance. He must indicate to the draftsman any parts of the manuscript that are to be redrafted prior to reproduction and any features, notes, or names that are to be deleted or changed.

### 845 GEOGRAPHIC NAMES

Each manuscript, together with the Descriptive Report containing a list of geographic names for that manuscript (7261-48), is forwarded to the Geographic Names Section for verification of the spelling and placement of all geographic names. Changes by the Geographic Names Section are made on the name list in the Descriptive Report.

## 846 HYDROGRAPHY

Practically all future topographic maps of the coastline will include some hydrographic data. These data will generally be limited to the low-water line, depth curves, and a few soundings, although some maps will show rather complete hydrographic data. Consequently, after other phases of the review have been completed each topographic manuscript is ordinarily forwarded to the Nautical Chart Branch for the addition of hydrography from the latest hydrographic surveys.

The addition of hydrography to a topographic manuscript is the sole responsibility of the Nautical Chart Branch, which inserts a record in the Descriptive Report giving the origin and date of the source material, and the names of persons applying and verifying the hydrography. When the hydrography is applied to a topographic map, particular attention is given to the completion of the low-water line and the addition of rocks and obstructions.

## 847 REVIEW REPORT AND REGISTRATION

After all other phases of the review have been completed, the reviewer prepares a formal review report which is inserted in the Descriptive Report (see 72, par 3). This report is prepared from notes kept by the reviewer during the progress of his work, starting with the office inspection (83).

The review report and reviewed manuscript are inspected by the Chief of the Review Section, or his assistant, and the report initialed, indicating approval. The manuscript, drafting overlay, and Descriptive Report are then forwarded for smooth drafting.

## 8471 Review Report

The review report does not repeat information contained in the preceding parts of the Descriptive Report (72). Consequently, before writing his report the reviewer must see that the preceding parts of the Descriptive Report are complete and specific, particularly those entries on the Data Record to be made by the Washington Office and the introductory statement (7232). He must be sure that all ambiguous statements in the text of the Descriptive Report have been clarified by inked notes or referenced to an explanation in the review report and that adequate references have been made in the Descriptive Report to other special reports.

Unnumbered pages containing notes for the compiler, notes for the reviewer, and similar temporary entries inserted in the report at various stages, which are not important as a permanent record, are removed from the report (see 724 and 7261).

The subject matter and length of the review report vary considerably from project to project and even between individual maps on the same project. Each review report shall be typed in duplicate. It shall be arranged in accordance with the following outline and shall always contain the listed headings, additional numbered paragraphs being used where apropos to cover other items of importance which should be a matter of permanent record.

The heading of the review report shall include the map number, as *T-8039*, the type of map, as *topographic*, *planimetric*, or *shoreline survey*, and the date of the Washington Office review.

Each review report shall be signed by the reviewer and the Chief of the Review Section. Each review report will also be signed by one or more representatives of the Division of Photogrammetry, the Division of Nautical Charts, and the Division of Coastal Surveys.



**OUTLINE FOR REVIEW REPORT**  
**REVIEW REPORT T-**  
 Type of Map  
 Date

**61 General Statement**—Include any information regarding the major steps in the preparation of the map, special circumstances regarding preparation, or use, or other information which the chart compiler, or others, using the map should know, and which has not been adequately reported in other parts of the Descriptive Report. This information will ordinarily be included in the preface (7232) and where that is so item 61 of the review report should be omitted, but it is needed occasionally.

**62 Comparison with Registered Topographic Surveys**—(This phase of the review, and the information to be included in the review report, are explained in 8431.)

**63 Comparison with Maps of other Agencies**—(The maps with which the manuscript was compared shall be listed by name, date of edition, and producing agency. Information contained in the compilation report (7261) is not repeated and often no text is required under this heading.)

**64 Comparison with Contemporary Hydrographic Surveys**—(This phase of the review and the information to be included in the review report are described in 8433. If there are no contemporary hydrographic surveys, the heading shall be followed by "NONE".)

**65 Comparison with Nautical Charts**—This phase of the review and the information to be included in the review report are described in 8434.

**66 Adequacy of Results and Future Surveys**—State whether the map complies with the instructions and discuss any inadequacies, listing any items to be investigated when future surveys are made in the area. Report any areas in which features are omitted from a published map for security reasons and give authority. Mention any accuracy tests and their results. State positively whether or not the map complies with the National Standards of Accuracy.

**67** Additional paragraphs numbered consecutively beginning with 67 may be added by the reviewer as needed.

#### *8472 Inspection of Map Manuscript after Review*

After the Washington Office review has been completed, the review report and manuscript are inspected by the Chief of the Review Section, or his assistant, and approved by initialing the report in the place for signature of the Chief of the Review Section. The report is not actually signed by him until the lithographic copy to be registered is available and has been examined.

#### *8473 Registration*

Each map is registered in the Bureau Archives as soon after the Washington Office review as the special copy described in 8237 can be prepared.

Planimetric maps and shoreline surveys are drafted and reproduced by the Bureau. The special copy of each of these maps or surveys is ordered from the Reproduction Branch immediately after the proof edit (857). This copy of the map is examined by the Chief of the Review Section, or his assistant, who then signs the review report and forwards the report and the copy of the map to the Chief, Division of Photogrammetry for approval, after which the map is routed to various Divisions for examination and approval and is registered in the Bureau Archives as stated in 8237. The carbon copy of the review report is occasionally initialed by the Chief, Division of Photogrammetry and forwarded to the photogrammetric office where the manuscript was compiled.

Two copies of each topographic map are registered in the Bureau Archives, a copy of the manuscript prior to smooth drafting and publication, and a color print of the published map, as stated in 8237. The manuscript copy is ordered from the Reproduction Branch as soon as the reviewed manuscript is received in the Drafting Section. This manuscript copy is delivered to the Review Section and is forwarded for registering as described in the preceding paragraph. When the map is published, a cloth-backed copy of the published map is ordered by the Review Section and forwarded by that section to the archives for filing with the manuscript copy.

It is the responsibility of the Review Section to keep adequate records of progress of each manuscript from its receipt in the Washington Office until it is published and registered in the Bureau Archives, in the case of topographic maps, until the published copy of the topographic map is filed in the archives with the manuscript copy as stated in the preceding paragraph.

## 85 SMOOTH DRAFTING AND PUBLICATION

### 851 GENERAL STATEMENT

This section describes the general procedures involved in the publication of maps from photogrammetric manuscripts, but does not include detailed instructions for drafting, engraving, or map lettering which are contained in Washington Office memoranda.

The several types of photogrammetric map manuscripts and the maps published from them are described in 15. Planimetric maps are printed in one color and are distributed by the Coast and Geodetic Survey. Shoreline surveys are not printed in quantity for distribution, but are retouched and relettered prior to reproduction and registry in the Archives. Topographic maps are reproduced and distributed by the U S Geological Survey, although the reproduction copy may be prepared either by the Coast and Geodetic Survey or Geological Survey, depending on administrative decision.

The content, format, symbolization, and lettering of topographic maps produced by the several agencies of the Federal Government, have recently been standardized through an exhaustive study by an interdepartmental committee. The resulting specifications are available to all agencies and are followed by the Bureau in preparing reproduction copy for topographic maps. These specifications are also generally followed in preparing smooth copies of planimetric maps, although some departures are made, inasmuch as planimetric maps of the Coast and Geodetic Survey are distributed as *copies of surveys of a particular date*, rather than as maps, and they are not as formal in format and symbolization as topographic maps are.

Two editions of each topographic map are generally prepared—a civil edition for public use which is published by the Geological Survey, Department of the Interior, and a military edition which is published by the Department of the Army. One significant result of the work of the interdepartmental committee mentioned in the previous paragraph is that the reproduction copy of topographic maps is prepared so as to be usable for reproduction and printing of either the civil or military edition with a minimum of redrafting.

### 852 PREPARATION OF REPRODUCTION COPY

Reproduction and printing of a map involves these principal steps

(a) Preparation of reproduction copies of the original map manuscript either by pen and ink drafting on paper, or by negative engraving, a separate drawing or engraving being made for each color in which the map is to be printed. Topographic maps are usually printed in five or more colors.

(b) Map lettering by the stick-up method, that is, by printing the names on cellophane, or paper, and pasting them in position on a blue line print of the compilation or sometimes on the manuscript itself.

(c) Preparation of negatives and printing plates from the reproduction copy by photographic process

(d) Printing a limited number of copies for proof edit

(e) Correction of the reproduction negatives or printing plates after proof edit

(f) Final printing for distribution

The reproduction copies (smooth copies) mentioned in (a) may either be drawn on paper in ink or be engraved on glass negatives, the processes being essentially similar. In either case the map manuscript is photographed and all lines and symbols are redrawn or recut prior to reproduction and printing.

To prepare smooth copies by negative engraving, as many duplicate wet-plate negatives (copies of the manuscript) are made as there are to be colors in the printed map. On each negative all lines and symbols to be printed in one particular color are engraved, by recutting the lines and symbols of the original manuscript which are visible on the negative. Names and notes are not ordinarily engraved but are printed and stuck in position on a blue-line copy of the manuscript which is then photographed to obtain a reproduction negative from which the names are printed.

Whether the smooth copies of a map should be prepared by pen and ink drafting on paper or by negative engraving depends on many factors discussion of which is beyond the scope of this manual. At this time most of the topographic maps are smooth-drafted by pen and ink.

For smooth drafting, a glass negative of the map manuscript is first made and from this a number of photographic blue-line prints are made on metal-mounted drawing paper, there generally being one blue-line print for each color in which the map is to be printed. These blue-line prints are usually called *color-separation boards*, and smooth *color-separation drawings* are made on them by tracing on each board, in black ink, all the lines and symbols to be printed in that specific color. All names and notes are printed on cellophane, or paper, and stuck in position on the appropriate color-separation drawing—names to be printed in black being placed on the black drawing, etc.

After the smooth drafting of lines and symbols and the lettering have been completed, each drawing is verified against the manuscript, and final color-separation negatives are then made from which the printing plates are prepared.

A few copies of each map are printed for proof edit and, following the proof edit, the reproduction negatives or printing plates are corrected prior to final printing for distribution. There are many variations in the general procedures described above, for example, proof copies in one or more colors may be prepared by photographic processes rather than press printing, and marginal names and notes that are the same for a number of maps, may be set up on a separate negative and processed directly to the printing plate and not lettered on each map drawing, etc.

### 853 PLANIMETRIC MAPS

Planimetric map manuscripts are usually compilation-drafted (51) and are completely redrawn prior to reproduction. Each planimetric map, with the exception of some of those in Alaska, is printed and distributed by the Bureau as a copy of a large-scale survey of a particular date. The sheet size, format, and style of planimetric maps are, therefore, less formal than is necessary for standard topographic quadrangles. Due to the large scales, the maps are generally not congested and one-color prints are satisfactory.

A smooth drawing is made on a blue-line board as described in 852—only one drawing being required if the map is to be printed in one color. The smooth draftsman refers to the original manuscript and Descriptive Report for clarification of detail, and questions of interpretation that cannot be settled from such reference are taken up with the reviewer. The

size of planimetric maps and shoreline surveys is such that each map is usually photographed and smooth-drafted in two halves. After completion of the drafting and lettering, the two sections are photographed on two glass negatives, which are then processed onto a single printing plate. Planimetric maps and shoreline surveys are drafted and printed at, or nearly at, compilation scale—they are not reduced to a smaller publication scale.

In some instances planimetric manuscripts are *smooth compilation-drafted* (5), in which case they are not redrafted in the Washington Office but are handled in the same manner as shoreline surveys (854).

#### 854 SHORELINE SURVEYS

Shoreline survey manuscripts are ordinarily *smooth compilation-drafted* (5) and are not redrafted in the Washington Office. However, in the future all lettering will be “stuck-up” in the Drafting Section prior to reproduction and any lines and symbols needing it will be retouched, or partially redrafted, as necessary for clear reproduction and printing.

In preparing a shoreline manuscript for reproduction, the draftsman follows the instructions contained in the drafting overlay mentioned in 844. Generally, the hand-lettered names are erased from the manuscript and replaced by stick-up on the manuscript. Sections of the drawing to be retouched, or redrafted, are rubbed down and redrafted on the manuscript. However, where the parts cannot be erased and redrafted satisfactorily on the original manuscript, a negative of the manuscript is made. Parts of the manuscript to be revised, including names to be relettered, are painted out on this negative and a contact print on clear vinylite is then made from the negative. Names are stuck up on the vinylite print, and everything that was painted off the negative is now smooth drafted on the clear vinylite print, which then becomes the smooth copy for reproduction.

#### 855 TOPOGRAPHIC MAPS

Irrespective of where a topographic map is to be smooth-drafted, a glass negative of the map manuscript is made immediately after review and from this negative a black and white lithographic print is made on cloth-mounted paper for registry in the Bureau Archives, as described in 8237 and 8473. If the map is to be smooth-drafted in the Coast and Geodetic Survey, the same glass negative is used to prepare color-separation boards, as described in 852.

Topographic maps are drafted as described in 851. The draftsman has the manuscript and Descriptive Report available for constant reference, and confers with the Review Section regarding questionable interpretations of map details. After the drafting has been completed and verified, the color-separation drawings are forwarded to the Geological Survey for name lettering, reproduction, and publication.

Many of the topographic maps of Alaska coasts produced by the Bureau at a scale of 1:20,000 are not to be published as large-scale topographic maps. These are handled in much the same manner as shoreline surveys (854), they are redrafted, retouched or processed on clear vinylite (854) as necessary to obtain clean, legible copy and a one-color lithographic print is made for registry.

#### 856 VERIFICATION OF DRAFTING

All smooth drawings are verified against the manuscript by another draftsman and inspected by the Chief of the Drafting Section prior to reproduction.

#### 857 PROOF EDIT

A proof copy of each map is edited in the Division of Photogrammetry prior to printing and distribution. This edit comprises a careful inspection of all map details to verify the

accuracy of reproduction with reference to the map manuscript, and the quality of reproduction with reference to accepted Bureau standards. The proof edit does not repeat any phase of the review described in 84 but is largely a matter of comparative checking and may be done, in large part, by an employee other than a reviewer, but each proof is always finally inspected by the reviewer who reviewed the manuscript prior to drafting.

The proof copy of a planimetric map consists of either a set of contact prints made from the reproduction negatives, or a lithographic print made on the proving press. Corrections are marked in ink on this copy which is returned to the Reproduction Branch for use in correcting the negatives or printing plate prior to printing. If there are numerous corrections, a second proof may be submitted prior to final printing. After all proof-edit corrections have been made on the negatives or printing plate, a black and white lithographic print on cloth-mounted paper is made for registration, as mentioned in 8237 and 847.

No proof copy, as such, is made for shoreline surveys, since they are not to be published. The special cloth-backed print described in 8237 and 8473 is reproduced and a few prints are also made on chart paper and filed with the manuscript. The cloth-backed copy is edited prior to registration and minor corrections are made by drafting directly on that copy. If major corrections are found, the negatives or the printing plate is corrected and a new print is made for registration.

Proof copies of topographic maps are forwarded to the Bureau from the Geological Survey prior to publication.

The proof copies usually consist of one-color composite prints made from the several color-separation negatives but other times proof copies are press prints in color. These are edited and all corrections are noted on one copy, which is returned to the Geological Survey for correction of the drawings or press plates prior to publication.

A proof copy of each type of map is forwarded to the Geographic Names Section for verification of the names, inasmuch as they have been printed and stuck-up since any prior verification.

## 86 PROJECT COMPLETION

After all maps in a project have been reproduced and registered, all records of that project remaining in the Division of Photogrammetry files are examined and disposed of as stated in 8238. The Chief of the Review Section assists the File Section in appraising the records and deciding which of the miscellaneous records may be destroyed. Certain records, as listed in 8238, are always retained.

The last work item of a project is the preparation of a project report in the Review Section as described in 8238(e). The separate reports listed in 8238(e) together with indexes of horizontal and vertical accuracy tests, and any correspondence regarding technical phases of the work of value as a permanent record, are bound with a copy of the project instructions to form one composite project report which is filed in the Bureau Library. The Review Section prepares a general index to facilitate reference to the various parts of this report, and prepares a summary of the report. The summary is devoted mainly to conclusions about, (a) the adequacy of the maps, (b) the efficiency of the various phases of the work, (c) items about which additional information is desirable and which should be obtained when future surveys are made in the area by any field party of the Bureau, (d) changes in equipment and methods desirable for future similar projects.

## 87 RECORDS OF PUBLISHED MAPS

The essential records of published maps prepared by photogrammetric methods are kept by the Review Section and are described herein.

## 871 RECORD OF PUBLISHED MAPS

The ledger record of published maps contains the following entries for each map, which begin at the time the map is registered

- (a) Registry date
- (b) Publication date
- (c) Record of the existence of a standard showing errors on the published map
- (d) Date of each reprinting of the map
- (e) A record of the corrections made at reprinting

The record described above is supplemented by standards discussed in 872

## 872 STANDARDS

A standard consists of a copy of a published map, which shows the date at which it was placed in the file of standards. A standard for a particular map is not placed in the file until an error or correction is reported for that map, at which time a standard is prepared and the errors or corrections are noted on it in colored ink, and dated.

When a map is reprinted, the file of standards is consulted and if errors or corrections have been reported for that map, the standard, or a copy of it, is forwarded to the Reproduction Branch for correction of the reproduction negatives prior to reprinting. The fact that these corrections have been made and the date are entered in the ledger record, and if all the corrections shown on the standard are applied, as they usually are, the standard is then discarded and a standard for that map is not again entered in the file of standards until additional corrections or errors are reported.

Topographic maps are printed and distributed by the Geological Survey. Corrections noted on the standards for topographic maps are reported immediately to the Geological Survey if of immediate importance, otherwise they are reported when the Bureau is informed that the map is to be reprinted.

The standards are maintained solely for recording errors in the original edition of the map and cultural and physical changes that are brought to attention by means other than systematic resurveys, this latter information is recorded on the diagrams of all surveys maintained in the archives and on the Nautical Chart Standards. (See also 883)

## 873 MAP INDEXES

Graphic indexes showing all shoreline surveys, planimetric maps, and topographic maps prepared by photogrammetric methods, are published by the Bureau. Map indexes of the United States are arranged by quadrangles  $1^\circ$  by  $1^\circ$  in size, those of Alaska by quadrangles in varying degrees of latitude and longitude. Shoreline surveys and planimetric maps are shown on these indexes in black outlines, topographic maps are shown in red outlines. The indexes are frequently revised so as to show not only published maps but those nearing completion.

Shoreline surveys are not published, but are shown on the indexes for convenience, inasmuch as photographic copies of them can be obtained at the cost of reproduction.

Topographic maps compiled by the Bureau are published and distributed by the Geological Survey, but are shown on the indexes for convenience, and photographic copies of the map manuscripts can be obtained for the cost of reproduction, pending publication. Even after publication photographic copies of the manuscripts are sometimes desired by private surveyors and others for use in conjunction with the published maps, inasmuch as the manuscripts are at a larger scale.

The Drafting Section is responsible for the preparation and revision of the map indexes as frequently as necessary to show new maps. A set of standards is maintained in the Drafting Section for this purpose.

## 88 MAP REVISION

### 881 GENERAL STATEMENT

Much of the coastline is subject to continuous change and frequent resurveys are necessary for the maintenance of nautical charts. Topographic, planimetric, and shoreline maps, when once completed and registered as described in preceding chapters of this Manual, serve as bases for periodic revisions from new aerial photographs.

Each map revision is made to meet the requirements of a specific chart, consequently, the revisions vary considerably in extent, accuracy, and content, though all revisions discussed under this heading are made from aerial photographs. The method may include field inspection of the photographs prior to revision of a map, or field edit after revision, but in many instances is limited to office compilation from the aerial photographs without any field work.

Generally, a lithographic print of a particular topographic map, planimetric map, or shoreline survey is made in red ink on transparent vinylite, or cellulose acetate. The revisions are then made in black ink on this base sheet from aerial photographs by graphic or stereoscopic methods. The contrasting colors identify the changed and unchanged details. The entire map sheet can be photographed for reproduction as a revised map if this is desired.

### 882 REVISIONS OF LIMITED EXTENT

Many revisions made from aerial photographs cover scattered small areas in one or more maps, and are usually made directly from aerial photographs without field examination. These revisions may be made on a base sheet as described in 881, but are often simply made on paper prints of the original map by means of the map projector (143).

Revisions of small areas, as described in this subject, are usually cut up into letter-size sections and forwarded to the Nautical Chart Branch, where they are filed as *chart letters*. Each chart-letter section, or a group covering the same general area, is accompanied by an informal memorandum stating the date of photography, the method of making the revisions, and any information about the changes pertinent to nautical charts. The *chart-letter file* in the Nautical Chart Branch contains the miscellaneous information submitted by field parties, and others, for the correction of nautical charts. Each communication is known as a *chart letter* and is given a consecutive number within each calendar year. *Chart-letter* sections must be cut to letter size and so arranged as to include all notations and revision data for the particular small area. Revisions too large to be conveniently filed in this manner, are submitted and filed as stated in 883 and 884.

### 883 EXTENSIVE REVISIONS OF STANDARD ACCURACY

In some instances, the changes in an area are so extensive, or so important, that field surveys, either field inspection prior to compilation or field edit, are required and the revisions include all, or nearly all, the shoreline covered by one or more topographic maps, planimetric maps, or shoreline surveys. Under these circumstances, the field surveys and compilation are usually made in accordance with the requirements of this Manual as to content and accuracy, and the revised map is treated as a new survey. It is reviewed and registered as described in Sections 82 to 86 inclusive.

Such extensive revision is usually made on base sheets as described in 881. When a revision is treated as a new survey, all details on the original map base that have not been re-examined and brought up to the date of the field inspection or field edit, are deleted from the revision sheet, which becomes in effect a new map manuscript. An example of this, is when a planimetric map is used as a base but the revision is limited to the shoreline and alongshore details. In this case interior details of the original planimetric map are deleted from the new sheet, which is then made a shoreline survey with a new map number. A revision of standard accuracy and content as discussed in this subject, is *published* as a new planimetric map if the interior details are re-examined and revised to the date of the field surveys.

#### 884 EXTENSIVE REVISIONS OF LESS THAN STANDARD ACCURACY

The majority of map revisions are in this category. The field inspection and compilation for revision of a topographic, planimetric, or shoreline map for charting purposes, are generally limited to the information required for nautical charts, that is, to specific areas on the map, and do not include the entire map. The map contents, consequently, cannot be said to be completely revised and, though of sufficient accuracy for the particular charting purpose, the revision may not meet the accuracy standards for original photogrammetric surveys as described in 12.

Each map revision made at less than standard accuracy and content, is called a *revision sheet*, the term *revision sheet* replacing the former term *correction sheet*. Each *revision sheet* is given a number of the Division of Photogrammetry, as RS-532 and is routed and filed as follows:

(a) Each revision sheet is accompanied by a brief informal report which is made in duplicate and includes such information as the date of the photography, the type of photographs, the extent and completeness of field inspection, if any, the method of compilation, and other information about the methods or the results, which is pertinent to nautical charting, particularly, any known inadequacies which require field investigation at a later date.

(b) The revision sheet and report are delivered to the files of the Division of Photogrammetry for recording and routing.

(c) The revision sheet is recorded in a card index record, or catalog, of revision sheets and the sheet and report are filed in jackets in much the same manner as original manuscripts (8223).

(d) Photographic copies of the revision sheet are ordered from the Reproduction Branch, and one copy, together with the carbon copy of the revision sheet report is forwarded to the Nautical Chart Branch for entry on the *nautical chart standards*, after which it is filed in the *blueprint files*. A copy of each revision sheet is also forwarded to the Geographic Section.

Map revisions of less than standard accuracy are not reviewed and are not reported to the Review Section, nor are they entered on the standards of the Review Section, described in 87.

#### 885 NEW MAP MANUSCRIPTS OF LESS THAN STANDARD ACCURACY

New map manuscripts are occasionally compiled from aerial photographs without field inspection and without adequate control for standard accuracy mapping, for special uses of the Division of Charts, the Division of Coastal Surveys, or the Division of Geodesy. These manuscripts of less than standard accuracy, are called *provisional maps*, their use is described briefly in Chapter 9. Each *provisional map* is accompanied by a Descriptive Report similar to the report called for in 884, and the manuscript and report are numbered in the same series of numbers provided in 884.

Each *provisional map* is recorded and routed as specified in 884*b* to *d*.



## CHAPTER 9 MISCELLANEOUS

91 COORDINATION OF PHOTOGRAMMETRIC  
AND HYDROGRAPHIC SURVEYS

## 911 GENERAL STATEMENT

This subject describes the application of photogrammetry to coastal surveys for nautical charts. Until the advent of photogrammetry, coastal surveys were usually *combined operations* in which one Chief of Party was responsible for all surveys needed in a particular area for nautical chart purposes, including control surveys by triangulation or traverse, topographic surveys by planetable, hydrographic surveys, tide and current surveys, the collection of coast pilot data, etc. This was a practicable and efficient arrangement by which the different kinds of surveys were effectively coordinated. Photogrammetry has now replaced the planetable for most of the detailed mapping of land areas and this newer method, although it has many advantages, has introduced problems in the coordination of the surveys because the photogrammetric surveys and the hydrographic surveys are usually made at different times and by different Chiefs of Party.

Effective coordination between the photogrammetric and hydrographic surveys is essential and requires that the personnel engaged in each operation understand the objectives, and the advantages and limitations, of the other. Photogrammetry has improved the quality and efficiency of coastal mapping, but it is a relatively new method of surveying and much remains to be done in training Bureau personnel as to its advantages and limitations before it can be applied with maximum efficiency to the combined operation of surveying for nautical charts.

## 912 ADVANTAGES AND LIMITATIONS

The principal advantages of photogrammetry for coastal surveys are

(a) Detailed mapping can be done more accurately, completely, and efficiently than by planetable alone, this is obvious when the mapping of areas is considered. The advantages of mapping from photographs increase with the complexity of details to be mapped, as, for example, in harbor areas and along irregular coasts.

(b) Inaccessible areas can be mapped more completely and efficiently than by planetable. Some inaccessible parts of the coasts of the United States and much of the coastline of Alaska had never been mapped, except in the barest outline until the advent of photogrammetry, because of the inhospitality of the terrain and the extreme difficulty in traversing it.

(c) Photogrammetry transfers much of the labor of mapping from the field to the office, which is a distinct advantage where the field season is limited by weather, as it is in the higher latitudes. It also relieves the hydrographic party of most of the work of mapping shoreline and alongshore details thus providing more time for the actual sounding operations. Photogrammetry reduces but does not eliminate field work, which will probably always be necessary for accurate mapping.

(d) Maps can generally be produced from photographs with less ground control than is required for the planetable, this is particularly true where areas are being mapped and not just the shoreline.

Important limitations of photogrammetry for coastal surveys are summarized as follows

(a) Control stations (fourth-order stations) for controlling future hydrographic surveys and simple regular shoreline can usually be located more economically by planetable than by photogrammetric surveys. Photogrammetry requires aerial photography, field inspection and office compilation, the total operation is always rather complex and involves overhead costs which are often not warranted solely for limited surveys of regular shoreline and/or hydrographic control.

(b) Photogrammetric surveys are more difficult to coordinate with the hydrography because they involve the separate operations of field work and office compilation, which are not done under one Chief of Party. Surveys must be planned well in advance of any field work and photographs must be taken a year, and often two years, in advance of the hydrography for the most efficient operations.

Photogrammetric surveys have not replaced the planetable entirely, and probably never will, the latter is used to some extent in nearly all coastal mapping. In planning and making surveys of the coastline, the advantages and peculiarities of each method must be understood and the two effectively combined. Photogrammetry is more effective for the location of details, whereas the planetable is often better for the location of points. Fourth-order stations (photo-hydro stations, landmarks, etc.) can be located somewhat more accurately, that is, with less possibility of error, by planetable than by photogrammetric methods because the planetable method is more direct, photogrammetry always involves several phases, such as field identification and office compilation, and the possibility of mistaken identity or misunderstanding is thereby increased.

Pure blunders can, of course, occur in both planetable surveying and in photogrammetry, but there is less likelihood of a blunder in photogrammetric surveying because the small areas are so intimately tied together over a large area. On the other hand, small differential inaccuracies are likely to be more prevalent and of somewhat larger magnitude in photogrammetry than in planetable surveying. Two adjacent hydrographic control stations are likely to be more accurate with reference to the geographic datum when located photogrammetrically than when located by planetable, but the relative discrepancy in their positions is apt to be somewhat larger by photogrammetry than by planetable.

### 913 PROCEDURES

The arrangement and scheduling of the various phases of a coastal mapping project are preferably as follows:

<i>Phase</i>	<i>Name of Operation</i>	<i>Time</i>
1	Aerial photography	1st field season
2	Preparation of mosaics	1st winter
3	Control surveys	2nd field season
4	Photogrammetric field surveys	2nd field season
5	Compilation	2nd winter
6	Hydrography	3rd field season

The operations are not separated seasonally, as listed above, when weather permits continuous field work, but they are preferably done in the same order. The various phases of photogrammetry and hydrography cannot always be done in the sequence listed here. Exceptions are described in 915.

Mosaics are prepared from the aerial photography for use in project planning and for use as maps during field work, when maps of an area *do not exist*, or when the available maps are *inadequate*. The mosaics are based on radial plots to obtain a fairly uniform scale. Control stations, either astronomic or triangulation stations, if available, are approximately identified on the photographs in the office and the approximate scale and geographic orientation of the mosaics are determined from them. The exact scale of the mosaics and their geographic orientation are not known where no ground control is available—in this case the approximate scale of each mosaic is determined from the altitude at which the aerial photographs were taken. The scale of the mosaics varies from project to project, but is usually between 1:60,000 and 1:120,000. Such mosaics are prepared principally

for use in connection with surveys in Alaska. This paragraph does not apply to the simple shingle mosaics of single-lens photographs that are used solely as indexes.

Provisional planimetric maps (see 885) are sometimes compiled for use during the subsequent surveys. These are controlled by radial plots in the same manner as stated for the mosaics.

The necessary control surveys and the photogrammetric field surveys prior to compilation, phases 3 and 4, are sometimes combined under one Chief of Party or may be made by two separate field parties, depending on the extent of the control surveys. In Alaska photogrammetric field surveys are sometimes combined with the basic control surveys under one Chief of Party, but are more often made by a separate photogrammetric party after the primary control surveys have been completed.

Photogrammetric field surveys include

(a) The identification of triangulation stations on aerial photographs, and the establishment of occasional supplemental stations by triangulation or traverse.

(b) The establishment and identification of supplemental vertical control stations for use in stereoscopic contouring.

(c) Identification of the high-water line and clarification of the alongshore details on the photographs, selection, marking, and identification of photo-topo stations, distributed along the coast between triangulation stations so that no point on the coastline is more than one or two miles from a recoverable control station.

(d) Selection and identification of photo-hydro stations.

(e) Inspection of landmarks and collection of coast pilot data.

(f) Inspection and classification of interior details including the clarification of roads and buildings, the identification of boundary lines and public land lines, investigation of geographic names, etc.

On some projects in the United States, the photogrammetric field surveys include control leveling and contouring on aerial photographs in lieu of stereoscopic instrument contouring, as stated in (b).

Photogrammetric compilation, phase 5, preferably precedes hydrography and the photogrammetric manuscript provides the shoreline, the locations of photo-hydro stations, and the location of certain offshore details in the area of the hydrographic survey. Copies of the photogrammetric manuscripts in the form of film positives, or reversed tracing-paper prints, are furnished to the hydrographic parties for use in transferring shoreline, photo-hydro stations, etc., to the boat sheets. The field photographs and copies of the Descriptive Reports containing the descriptions of the photo-hydro stations are also forwarded to the hydrographer (see 914).

It is preferable but not always practicable, that photogrammetric field surveys and compilation precede hydrography. Hydrographic surveys are sometimes made concurrently with the field inspection and prior to photogrammetric compilation, in which case, control stations for the hydrography are located by planetable (graphic control surveys) and the photogrammetric manuscripts do not include photo-hydro stations. This method is entirely satisfactory insofar as the location of hydrographic control points is concerned, but the shoreline compiled from aerial photographs is not available during hydrography and this is a decided disadvantage to the hydrographer.

When the photogrammetric compilation precedes hydrography the hydrographic survey can check the offshore details located from the photographs and correct or supplement them by locating rocks and obstructions not visible on the photographs. When the hydrography precedes photogrammetric compilation, there is inevitably a certain overlap in the location of features outside the high-water line and coordination of the two surveys is more difficult.

In Alaska, control surveys, field inspection and hydrography, phases 3, 4 and 6 are sometimes completed as one combined operation—preceding compilation, phase 5, provisional planimetric maps are usually compiled from the photographs in this case and are furnished to the field party. Shoreline from these provisional manuscripts is transferred to the boat sheets to serve as a guide during hydrography. If the provisional manuscripts are uncontrolled, at least two ground control stations must be established and identified on each provisional manuscript before the shoreline from that manuscript can be transferred to the hydrographic boat sheet. (See also 737, Hydrographic Manual.) Standard photogrammetric manuscripts are compiled in the usual manner after the control surveys, field inspection, and hydrography have been completed, and the shoreline details from these manuscripts are transferred to the hydrographic smooth sheets.

#### 914 PHOTO HYDRO STATIONS

Photo-hydro stations are recoverable natural objects and cultural features, whose positions are determined by the photogrammetric survey for use as control in the following hydrographic survey. Photo-hydro stations must be recoverable up to the date of the hydrography—that is, for a period of 1 to 3 years, but they need not be permanent objects—that is, they need not be recoverable for a long period of time. Photo-hydro stations are never monumented or described on Form 524, as are recoverable topographic stations.

The location of photo-hydro stations involves the following distinct and separate work phases, each of which must be accurately done:

(a) The objects selected as stations should be so distributed as to provide a strong three-point fix in any part of the area to be sounded, each object must be recoverable without question (objects not readily recoverable must be marked or referenced, and trees used as stations or reference objects should usually be blazed), and each object must be accessible, so that the object itself, or a nearby location can be marked by the hydrographer.

(b) Each photo-hydro station must be positively identified on at least one field photograph.

(c) Each photo-hydro station must be accurately located on the photogrammetric manuscript, as described in Section 46.

(d) Each photo-hydro station must be *positively recovered* by the hydrographic party, descriptions and field photographs are provided for this purpose.

Photogrammetric surveys preceding hydrography can usually furnish most of the control stations needed but can rarely furnish all of them. It is difficult for the field inspector to obtain an ideal distribution of photo-hydro stations, and a few additional stations will usually have to be established by the hydrographer, even where natural objects are plentiful. Where natural objects are sparse, the number of photo-hydro stations will usually be insufficient but the photogrammetric survey will nearly always provide a sufficient number of stations so that additional ones can be located by the hydrographer with the sextant, or with a minimum of planetable work.

An occasional photo-hydro station will be erroneously located and must be segregated and rejected by the hydrographer, the error will almost invariably be due to one of two causes, either the station was identified incorrectly by the photogrammetric field party, or it was not recovered by the hydrographer. Examination of the station descriptions and the field photograph will show which station is most likely to be in error, and it is primarily for this reason that field photographs are forwarded to hydrographic parties. Most photo-hydro stations can be recovered from the written descriptions, but the field photographs are occasionally necessary to make certain of the identity of a station.

Photo-hydro stations are sometimes selected in the office without field inspection, as stated in 4612. This practice is not preferred but is occasionally necessary. Stations

selected in the office are specifically so designated in the descriptions. Such stations are located with the same accuracy as those selected by field parties but they are usually not so well placed, they may not be clearly visible from offshore, or they may be inaccessible for recovery and marking when situated on exposed coasts.

The accuracy of location specified in 122 applies to the manuscript on which the stations are located. This fact must be recognized when photo-topo and photo-hydro stations are used on planetable sheets or boat sheets at a scale larger than that of the manuscript on which they were located.

### 915 ALONGSHORE AND OFFSHORE FEATURES

Certain features in the water area, that is, seaward from the high-water line, are the dual responsibility of the photogrammetric and hydrographic surveys. For convenience of this description these features are classified as alongshore features, and offshore features. All such features that are clearly visible on the photographs can be located by the photogrammetric survey. Their character often cannot be determined from the photographs, so it may happen that the positions of features are determined whose exact character and elevation are questionable, unless these data are provided by the photogrammetric field party. The percentage of such features that is determined by the photogrammetric surveys depends on the stage of tide at which the photographs were taken. If the photographs were taken at the time of low water, all features above this plane can be located photogrammetrically, if their size is sufficient to make them visible on the photographs. Conversely, if the photographs are taken at or near high water, most of the features below this plane will not be visible on the photographs. Even when it is possible for the field photogrammetric party to locate certain of these objects, it is often more economical to leave them to be located by the hydrographic party, which has to cover all of the area anyhow.

#### 9151 Alongshore Features

Alongshore features include the foreshore area, the low-water line, and rocks and other obstructions lying close to shore *with little or no navigable water between them and the shore*. All the alongshore features are located by the photogrammetric survey when the photographs are taken at or near low water.

Some of the alongshore features, particularly the low-water line, are obscured when the photographs are taken at some higher stage of tide, and must be located, *not simply identified*, by the photogrammetric field party if they are to be shown on the photogrammetric manuscript. The completeness with which these *obscured* features are located by the photogrammetric field party and delineated on the photogrammetric manuscripts varies somewhat with conditions.

(a) *Hydrography soon after photogrammetric compilation*—The low-water line and alongshore features on precipitous coasts are located by the field inspector and delineated on the photogrammetric manuscripts, however, on flat coasts the low-water line that can be sounded over by the hydrographer and other alongshore features obscured on the photographs that can be reached by the hydrographer, are left for location by the hydrographic surveys.

(b) *Hydrography long after photogrammetric compilation*—Low-water line and alongshore features obscured on the photographs but of importance to navigation, are located by the photogrammetric field survey party and shown on the photogrammetric manuscript.

(c) *Hydrography immediately preceding photogrammetric compilation*—Low-water line and alongshore features obscured on the photographs but not likely to have been reached by the hydrographer, are

located by the photogrammetric field survey party and shown on the photogrammetric manuscript. When copies of the hydrographic boat sheets, or smooth sheets, are available to the photogrammetric field party, details obscured on the photographs, but located by the hydrographer need not be located by the photogrammetric field survey party or shown on the photogrammetric manuscript.

### 9152 Offshore Features

Offshore features include detached rocks (bare or awash), shoals, aids to navigation, and wrecks (bare or awash) that are within the limits of the photographs *but have navigable water between them and the shore*. The offshore features delineated on photogrammetric manuscripts will depend upon the scheduling of the hydrography as noted in subsequent paragraphs, inasmuch as it is not always practicable for the hydrography to follow immediately after the photogrammetric compilation.

(a) *Hydrography soon after photogrammetric compilation*—This is the preferable arrangement as mentioned in preceding sections. All offshore features clearly visible on the photographs are located on the photogrammetric manuscripts, although the character of some of these when not clearly discernible on the photographs may require clarification by the hydrographer. The photogrammetric field inspection survey ordinarily does not make a detailed inspection of offshore features when the area is to be covered in the near future by the hydrography. Offshore features not visible on the photographs are ordinarily omitted by the photogrammetric survey for later location by the hydrographer.

(b) *Hydrography long after photogrammetric compilation*—It is occasionally impracticable to schedule the hydrographic survey immediately after completion of the photogrammetric manuscripts and it is sometimes made only after a lapse of several years. The photogrammetric manuscripts include all offshore features clearly visible on the photographs and, in these cases, the character of the offshore features must be determined and indicated by the photogrammetric field surveys preceding compilation. Furthermore, the photogrammetric field surveys preceding compilation must locate by ground methods features of immediate importance to navigation, even though they are not visible on the photographs, so that these features can be plotted on the photogrammetric manuscripts.

(c) *Hydrography immediately preceding photogrammetric compilation*—Offshore features not visible on the photographs are not located by the field inspector, those clearly visible on the photographs are located by the photogrammetric survey, unless copies of the hydrographic boat sheets or smooth sheets are available to the photogrammetric field survey party and the photogrammetric compilation office. When copies of the hydrographic surveys are available detached rocks awash, shoals, channel lines and such features that cover at mean high water and that were located by the hydrographer are omitted from the photogrammetric manuscripts.

### 9153 Coordination of Survey

Where the photogrammetric survey is made prior to the hydrographic survey and copies of the manuscripts are available for the use of the hydrographer, it is incumbent on the hydrographer to complete the survey insofar as alongshore and offshore features are concerned, determining the position of all such features that have been omitted, determining the character of such features that have been located but whose character was undetermined, and sounding over the low-water line at high tide in order to delineate it by zero sounding where it has not been accurately located by the photogrammetric survey.

Each photogrammetric descriptive report includes *Notes to the Hydrographer* which point out previously charted features that could not be located during the photogrammetric survey, any other features whose interpretation by the photogrammetrist is doubtful, and features which require further investigation.

It is obvious from the preceding discussion that a satisfactory completion and coordination of the two surveys is practicable when the photogrammetric survey precedes the hydrographic survey. When the hydrographic survey precedes the photogrammetric survey, how-

ever, such coordination is impossible. In order to ensure that the two surveys are complete insofar as the water area is concerned, the hydrographic survey has to deal with all features about which there is any doubt in the hydrographer's mind whether they can be located photogrammetrically or not. As a result the hydrographic survey is compelled to locate more features than would be necessary were the conditions reversed and, even with the best of intentions, it will occasionally happen that a feature is not dealt with by either survey or there is a certain duplication of effort and there are sometimes minor discrepancies in character or position of these alongshore and offshore features. Such discrepancies are not apparent until after both field surveys have been completed and they must be evaluated and disposed of without actual ground inspection. To do this is troublesome and requires the greatest care and most careful judgment in the processing office and during the Washington Office review.

### 9154 Past Coordination Difficulties

Difficulties encountered in the past in coordinating photogrammetric and hydrographic surveys are described briefly here, so that they can be avoided in the future.

*a Photo-hydro stations*—Photo-hydro stations selected by the photogrammetric field survey parties have often been poorly distributed and did not provide strong fixes in the area to be sounded, and occasionally stations have not been visible from seaward. This has been due, mostly, to lack of experience on the part of the photogrammetric employee. Chiefs of photogrammetric survey parties must check and review the selection of photo-hydro stations and instruct field inspectors so that they will understand the placement of stations needed for hydrography.

Photo-hydro stations have often been poorly marked for recovery and the hydrographer has found it impossible to recover them. Features not readily recoverable must be referred to other prominent objects or clearly marked in some manner. Trees used as photo-hydro stations should be blazed, unless a tree is so situated that it cannot be confused with another or unless the property owner objects to the trees being blazed, in the latter case trees used for photo-hydro stations must be selected and described with great care to assure recovery.

Photo-hydro stations have not been recovered by hydrographic parties in some instances because the field inspection photographs were not available to assist in the recovery of a station. Field inspection photographs will be made available to hydrographic parties in the future.

Photo-hydro stations have been erroneously located on the photogrammetric manuscripts because of incorrect identification in the field, or because the field identification could not be transferred to all of the office photographs. This has often been due to the effort of photogrammetric parties to select and identify photo-hydro stations where suitable sites were not available. Photo-hydro stations must be omitted when identifiable objects cannot be found, omission of a station is preferable to an erroneously located station.

*b Offshore features*—Offshore features have been identified incorrectly on photographs and, consequently, incorrectly located on the manuscripts. This condition is particularly troublesome and must be avoided. Offshore features that are not definite and clear on the photographs are difficult to identify correctly. The field inspector when identifying such features must study the charts and if there is any question as to the exact identification of a feature, such as a shoal, rock awash, submerged rock, etc., it must be located by ground survey methods, or the identification must be checked or supplemented by a fix or one or more horizontal directions.

*c Use of photogrammetric manuscripts*—Photogrammetric manuscripts have occasionally been enlarged to twice the compilation scale and the position of photo hydro stations and photo-topo stations used as a basis for planetable graphic triangulation with resulting inaccuracies and disappointment. The accuracy of location of photo-topo stations and photo-hydro stations specified in 122 applies at the scale of compilation. The possible inaccuracies of 0.3 to 0.5 mm are enlarged when the manuscript is enlarged and this fact must be considered in using enlargements for other surveys. It is practicable to enlarge shoreline from the photogrammetric manuscripts for use on hydrographic sheets at a larger scale if the small resultant inaccuracies are considered. The positions of photo-hydro stations and photo-topo stations on the enlarged manuscripts may also be used satisfactorily for hydrography if the resulting inaccuracies are understood and considered, but photogrammetric stations on such enlargements can

rarely if ever, be used to extend control, that is, as a basis for location of additional control stations for hydrography, since the inaccuracies are likely to increase as the control is extended

## 92 TRIMETROGON MAPPING

The Coast and Geodetic Survey sometimes obtains trimetrogon photographs from other agencies to supplement its own vertical photography and to use in certain special mapping problems. A rectoblisque plotter, a universal sketchmaster, and a Wilson photoalidade are used to compile the map data from trimetrogon and oblique photographs. The instruments and methods are discussed briefly here without attempting to give detailed instructions for their use. Special detailed instructions for operating the instruments are contained in a forthcoming manual by the Aeronautical Chart Service of the U S Air Force entitled "Reconnaissance Mapping with Trimetrogon Photography, (Revised) "

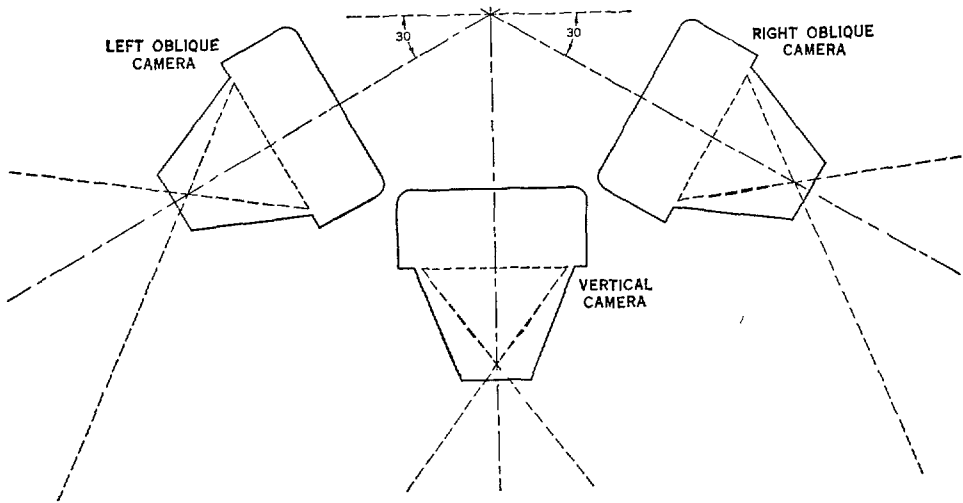

FIGURE 9 1—Relative arrangement of trimetrogon cameras

"Trimetrogon" is a coined word that indicates the use of three cameras, each of which has a 6-inch metrogon lens of  $90^\circ$  angular field of view and takes a photograph 9 inches square (see also 224). One camera is pointed vertically downward from the airplane (fig 9 1), one is pointed to the right with its axis inclined  $30^\circ$  below the horizontal and perpendicular to the longitudinal axis of the airplane, and the third camera is pointed to the left in a similar orientation. The three cameras are usually mounted in the framework of the airplane so that generally there is no adjustment for the tilt and crab of the three-camera unit, but this is not a serious handicap. Usually the cameras are mounted close together for convenience, but they can be placed in different parts of the airplane as long as they are pointed in their proper respective directions. However, if the cameras are located in widely separated parts of the airplane, the strain of the airplane in flight can change the relative orientation of the cameras so as to introduce difficulties into the map compilation procedure. The three cameras are operated simultaneously by one intervalometer so that three photographs are obtained from the same point in space at each exposure.

The success of the trimetrogon system depends on three principles: (1) the three photographs are taken from the same place, (2) an image of part of the horizon appears in each of the oblique photographs, and (3) there is an overlap between the vertical and each



of the obliques in which common images can be identified. Hence the three photographs show a continuous strip of terrain from one horizon, beneath the airplane, and on to the other horizon. The positions of the horizon lines and common images in the overlap areas furnish data from which the tilt of each of the three photographs can be determined in a comparatively easy manner.

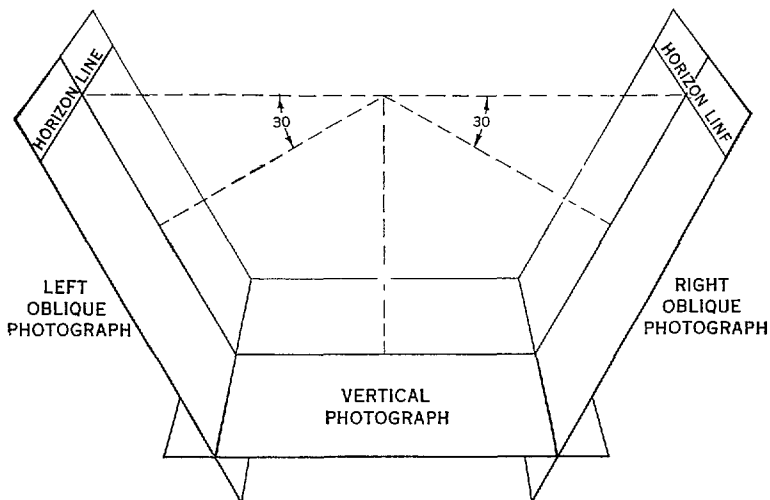

FIGURE 9 2—Relative arrangement of trimetrogon photographs

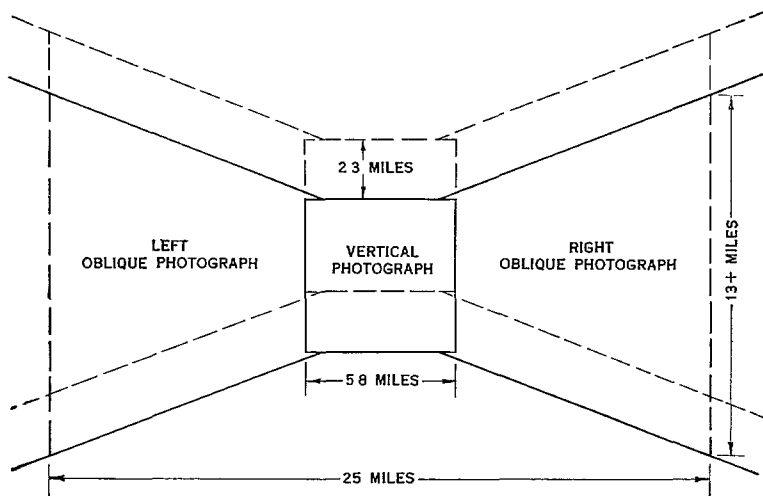

FIGURE 9 3—Utilized coverage of trimetrogon photographs

Trimetrogon photographs are normally taken at a flying height of 20,000 feet above the average terrain, whence the approximate scale of the vertical photograph is 1:40,000. Successive vertical photographs are overlapped 60 per cent in line of flight, and the flight strips are usually not farther apart than 25 miles. Map detail can be compiled to 12½ miles on each side of the line of flight (figs 9 2 and 9 3), the area usable for compilation extending to about 1 inch beyond the principal point of an oblique. Images of objects midway be-

tween flight strips appear on five or six successive photographs of each flight although the images on the vertical photographs appear on only two or three photographs

The exact relative orientation of the three cameras is determined from the photographs by considering images in the areas of overlap between the vertical and oblique pictures. The absolute orientation of the oblique cameras is indicated by the horizon lines as discussed in **3731**. The tilt data of the vertical photograph are derived from the oblique photographs together with the interrelation of the cameras. The oblique photographs are used in the form of contact prints and photographic rectification is not performed. The rectoblque plotter is an instrument that simplifies the graphic determination of horizontal angles from the positions of images on oblique photographs (**3732** and **923**). The oblique sketchmaster (or a universal sketchmaster that is adjusted to use obliques) is an instrument with which one can transfer map details from the oblique photographs in rectified shape onto a planimetric map sheet. A vertical sketchmaster (or a universal sketchmaster that is adjusted to use verticals) is an instrument for transferring detail from a vertical photograph onto a planimetric map sheet at the same or a different scale. A vertical sketchmaster performs the same general function as the reflecting projector described in **143**.

The compilation procedure developed by the U S Geological Survey and the Department of the Air Force consists essentially of

- 1 Control identification, pass point selection and transfer between verticals and obliques, between overlapping photographs in the same flight strip, and between overlapping photographs in adjacent flight strips
- 2 Tilt determination of obliques and verticals
- 3 Construction of paper radial-line templates using the rectoblque plotter, combination of radial lines from the three photographs of a set into a single composite paper template for use at 1:80,000 scale
- 4 Construction of metal (spider) templates from the paper templates
- 5 Assembly of metal templates into a radial plot to fit plotted control points (1:80,000 scale), and transfer of the resulting positions of pass points onto the map projection sheets
- 6 Compilation of terrain features onto the projection sheets from vertical and oblique photographs with sketchmasters, the features having been delineated on the photographs in a bright color with the aid of a stereoscope

Trimetrogon compilations made by the Geological Survey and the Air Force have been used as topographic bases for aeronautical charts at scales of 1:250,000 and smaller. Where ground control is adequate, the method is applicable, of course, to mapping of increased accuracy at a considerably larger scale from the same photographs.

## 921 THE WILSON PHOTOALIDADE

The Wilson Photoalidade (figure 3.56) is an instrument for measuring vertical angles to images quantitatively and horizontal angles graphically on horizontal and oblique photographs taken on the ground or from an airplane, obtaining the same angles that might have been observed with a planetable alidade located at the same place at which the photograph was taken. The device consists essentially of a telescopic alidade including a telescope with a crosshair and a vertical circle, an adjustable platen for supporting the photograph in a vertical or inclined orientation, and an alidade or horizontal-angle blade that moves with the horizontal rotation of the telescope. An optical collimator is incorporated on the telescope to locate the point where the vertical axis intersects a map sheet located on a table on which the instrument rests on legs 9 inches high.

The optical arrangement in the telescope is such that the crosshair is always on the vertical axis of rotation. The vertical circle is equipped with a vernier with which vertical angles can be read to the nearest minute of arc.

The distance (principal distance or focal length of a photograph) between the platen and the crosshairs of the telescope can be varied through a range of 4 to 14 inches by sliding the platen along its supporting arms. The arms are roughly graduated to correspond to the focal length of the camera with which the photographs were taken, but a given principal distance of the platen is accurately set with reference to the angle of the vertical circle subtended by two points on the platen that are in the vertical plane of the photoalidade and that are a known distance apart. The inclination (tilt) of the platen can be varied by a rotation of the platen and its supporting arms about a horizontal line through the crosshairs of the telescope, the motion being controlled by means of a clamp and a slow motion screw. A needle point at the center of the platen is used to locate the principal point of the photograph in its correct position, about which the photograph can be rotated in its own plane to compensate for the swing (3462) element of orientation. Thus, a known camera focal length can be set, and the instrument can be adjusted in tilt and swing until the readings for photograph images agree with ground control. After a photograph has been so adjusted, the tilt is indicated by the reading of the vertical circle when the telescope is sighted on the principal point.

A metal blade (alidade) is attached to the base of the vertical column of the telescope with a double hinge so that the blade and the telescope move together. Provision is made for unclamping the telescope from the blade and the setting of the blade relative to the telescope can be adjusted with a slow motion screw. The blade lays flat on the table and, because the friction between the blade and the paper is considerable, the telescope is rotated horizontally by manipulating the blade. The blade is a straightedge, one end of which always passes through the vertical axis of the telescope as indicated by the cross of the vertical collimator.

To operate the instrument, a photograph is placed on the platen and adjusted so that the true horizon line is in the horizontal plane through the center of the telescope. The crosshairs of the photoalidade are set on an image on the photograph, and then the angle on the vertical circle indicates the vertical angle of depression or elevation of the object, and a pencil line drawn along the blade represents the horizontal direction from the camera station to the object as in planetable surveying (see 37). It is thus possible to produce a radial templet (chapter 4) showing lines that represent horizontal directions to various images radiating from a common center which represents the nadir point of the photograph or the ground point vertically below the camera. The templet can be used along with other templates and with horizontal control to make a radial plot to determine the horizontal location of the camera station, the direction the camera was pointed (the orientation of the templet), and the locations of various objects by the intersections of radial lines to common images from two or more photographs.

A more recent model of the photoalidade is of more accurate and generally improved design and construction. It has also been proposed to make the platen transparent on the present model so that glass plate transparencies can be used instead of opaque contact prints. The U. S. Forest Service has developed a similar instrument called a "phototransit" with which the horizontal angles are read from a horizontal circle as on a transit, the alidade or blade being omitted.

## 922 SKETCHMASTERS

A sketchmaster is a relatively simple optical device with which it is possible to transfer lines and shapes of an original drawing onto a different surface with a pencil so that the copy is a duplicate of the original or is a nonorthogonally transformed perspective view of

the original at the same or a different scale. The sketchmaster sometimes serves the same function as the reflecting projector (143) although the latter is usually considered as being the more accurate. The principle of the sketchmaster, sometimes referred to as a "camera lucida," is illustrated in figure 9 4.

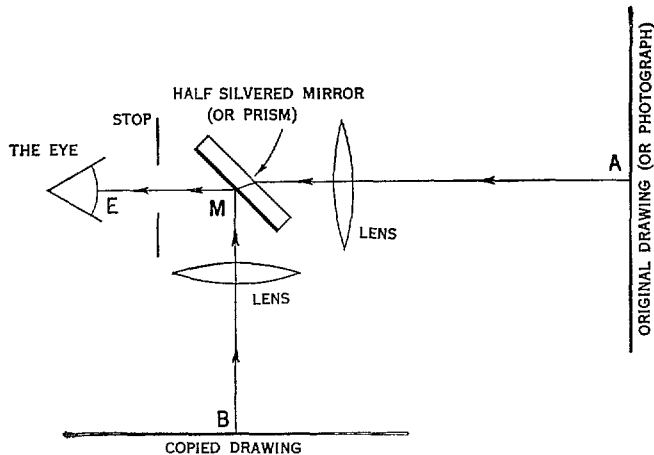

FIGURE 9 4—Principle of a sketchmaster

The essential part of the sketchmaster is a half-silvered mirror, prism, or other optical device, that reflects part of the incident light and transmits part of it. Thus, some of the light rays coming from an original drawing at *A* in the figure are transmitted almost undeviated to the eye, whereas rays from *B* are reflected at a right angle by the silver on the surface so that the rays from both *A* and *B* enter the eye, and images at *A* and *B* seem to be superposed. Hence a pencil point at *B* seems to be in contact with the surface at *A*, and the pencil in *B* can be moved to trace the shape of a feature that actually occurs in *A*.

If the distance from the prism to *A* or to *B* is changed, it should be evident that the size or scale of the copy at *B* will be altered accordingly. Thus it is possible to adjust the relative sizes of *A* and *B* by adjusting the dimensions *MA* and *MB*. One or more lenses are sometimes provided between prism and the copies to equalize the effective optical distances so that the eye can accommodate for the optical or virtual dimensions *MA* and *MB* at the same time. Various arrangements of the positions for the copy, the eye, and the prism have been used by different manufacturers. Most American models are also equipped with an additional mirror set at 45° between *M* and *A* permitting the original drawing or photograph to be laid flat. Such a mirror is usually of the front-surface type that requires special care as described in 1442. An optical stop near the eye and a headrest are needed to prevent the operator from moving his eye very far from the optical axis because any change in position of the eye causes relative motion of the superposed images. Density filters are sometimes employed along with the lenses to equalize the intensity of the light coming from *A* and *B*.

### 9221 *The Vertical Sketchmaster*

The vertical sketchmaster (fig 9 5) used by the Division of Photogrammetry of the Coast and Geodetic Survey is manufactured by Aero Service Corporation according to the design by Mr J L Buckmaster of the U S Geological Survey. The instrument is made

specifically to be used with 9- by 9-inch photographs for compilation at scales varying from somewhat larger than that of the original to one-half that of the original.

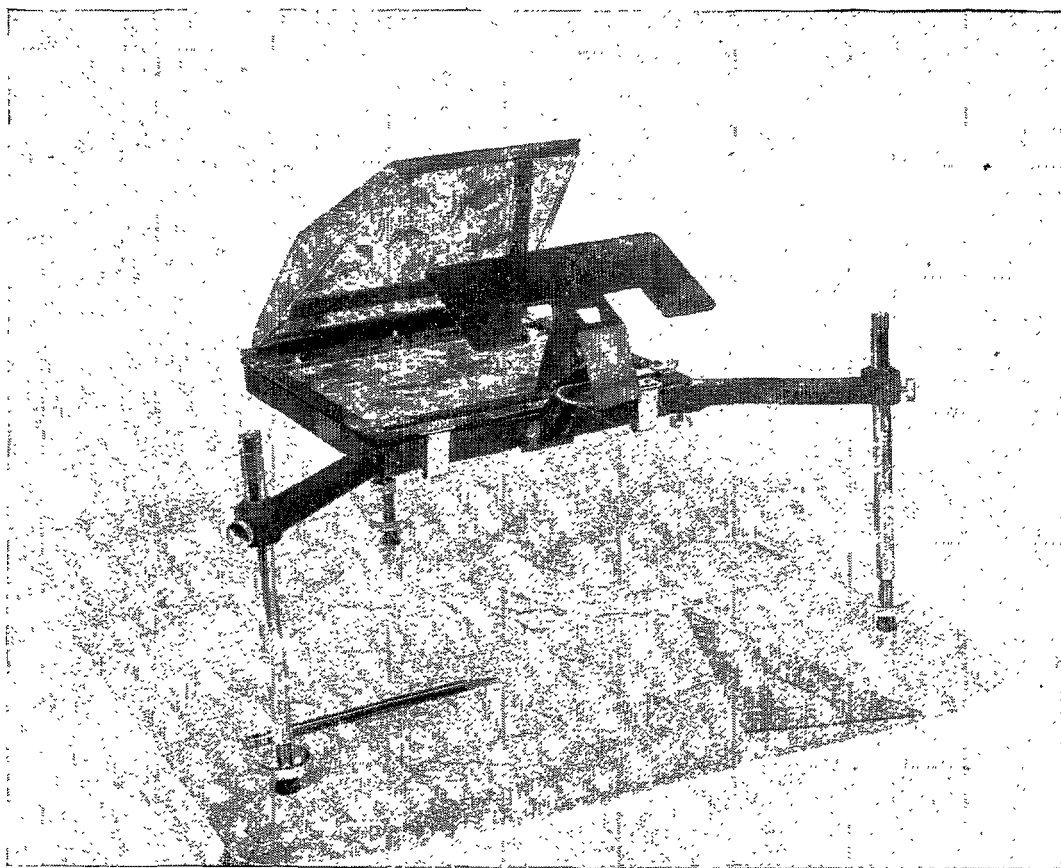

FIGURE 9.5.—Vertical sketchmaster.

The photograph lays in a horizontal position with clamps provided to hold it flat. The photographs are viewed in a large front-surface mirror inclined at  $45^\circ$ . The instrument is supported by three adjustable legs by which one can change the distance from the eyepiece to the copy, whereas the distance to the photograph is fixed. The legs are equipped with screw adjustments as well as clamps so that the photograph can be tilted to achieve partial correction for accidental tilt of the aerial camera. Lenses are provided for insertion between the half-silvered mirror and the copy to achieve optical accommodation. The operator looks downward through the eyepiece and a convenient headrest is provided. The instrument is made for use on a desk in daylight, but it is sometimes helpful to illuminate the photograph with a desk lamp.

The instrument is equipped with a convenient carrying case, the use of which requires unclamping and removing the legs, a very simple operation. An extra front-surface mirror, an extra half-silvered mirror, and a series of lenses are included in the equipment.

*9222. The Universal Sketchmaster*

A universal sketchmaster (figure 9.6) is used by the Coast and Geodetic Survey as an oblique sketchmaster where map detail is compiled from oblique trimetrogon photographs. This model also was made by the Aero Service Corporation according to the design of Mr. J. L. Buckmaster of the U. S. Geological Survey. The instrument is made specifically for 9- by 9-inch oblique trimetrogon photographs but can be used with either obliques or verticals throughout a range of tilts from  $0^{\circ}$  to  $80^{\circ}$ . However, the vertical sketchmaster (9221) is preferable for vertical photographs.

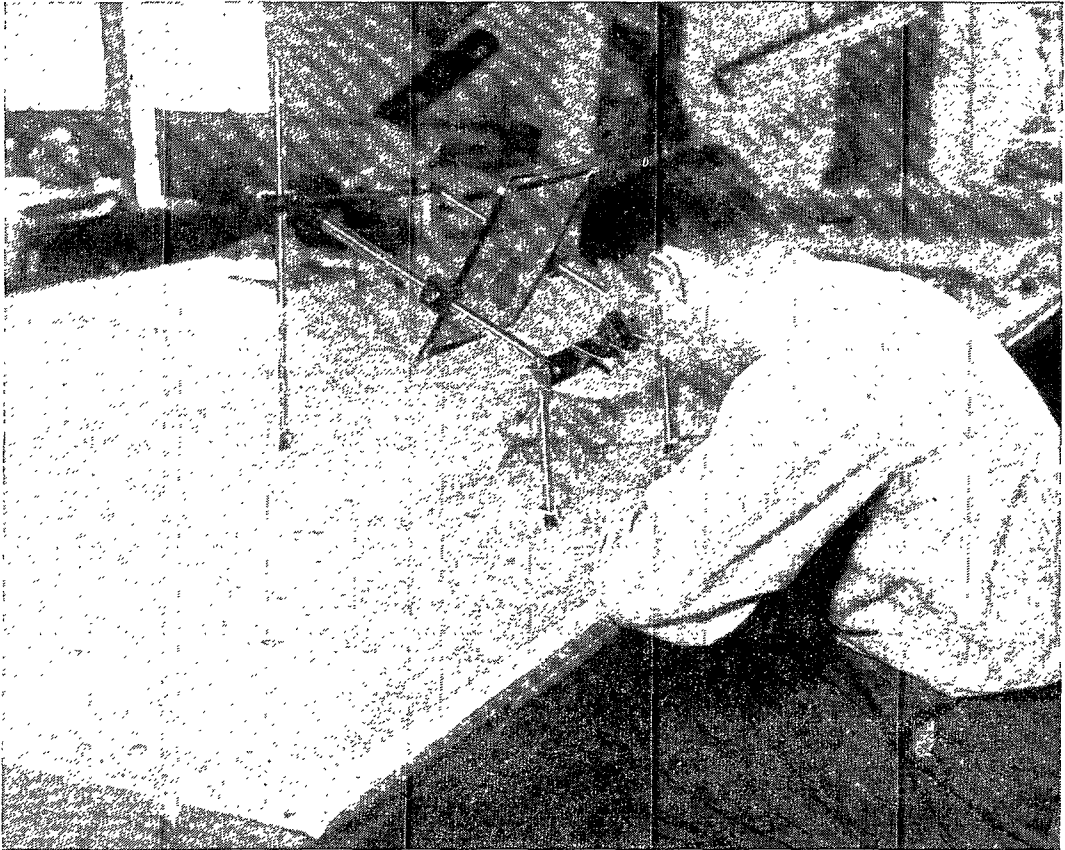

FIGURE 9.6.—Oblique sketchmaster.

One looks at the photograph as reflected from an internal surface of a small prism in the universal sketchmaster, inasmuch as a large mirror (see 9221) is not used. The instrument is simple in appearance and operation and is remarkably versatile. It is supported on three vertical rods, or legs, that are fastened to the body with fabric friction bearings (instead of clamps) with which the lengths and inclinations can be adjusted quickly and easily. Foot screws at the bases of the legs provide a slow-motion adjustment. The lengths of the two front legs control the scale of the transformation and the swing of the photograph, and the length of the rear leg controls the inclination or tilt of the oblique. The yoke that connects the frame to the rear leg is inverted for use with near-vertical photographs.

The platen on which the photograph is clamped is supported on two rods with screws for clamping. A scale in inches is on each rod for setting the focal length of the aerial camera, inasmuch as this dimension is important in the use of oblique photographs. The platen can be inclined  $90^\circ$  into a convenient position for inserting a photograph and then snapped back into operating position.

A cemented prism combination is used to accomplish the partial reflection instead of a half-silvered mirror. One views the copy *through* a small round aperture in one of the interior reflecting coatings while simultaneously seeing the original photograph reflected from the mirror-like surface that *surrounds* the aperture. The relative illumination of the two surfaces should be controlled because the relative brightness of the two copies depends to some extent on the size of the pupil of the eye, which in turn is affected by the brightness of the brighter surface. Consequently, the instrument is usually provided with a special lamp for illuminating either the photograph or the map, special clamps being used to hold the lamp in place.

A set of lenses is also included, any one of which can be inserted in a holder between the prism and the map. Lenses are seldom required for oblique trimetrogon photographs even for compiling at a reduced scale. A carrying case is also included with the instrument which folds into a very compact space.

### 923. THE RECTOBLIQUE PLOTTER

A rectoblique plotter (fig. 9.7) is an instrument with which one can graphically transform directions to images on oblique trimetrogon photographs into correct horizontal directions. The transformed directions correspond to those that one might obtain with a plane-table alidade located at the same point from which the oblique photograph was taken.

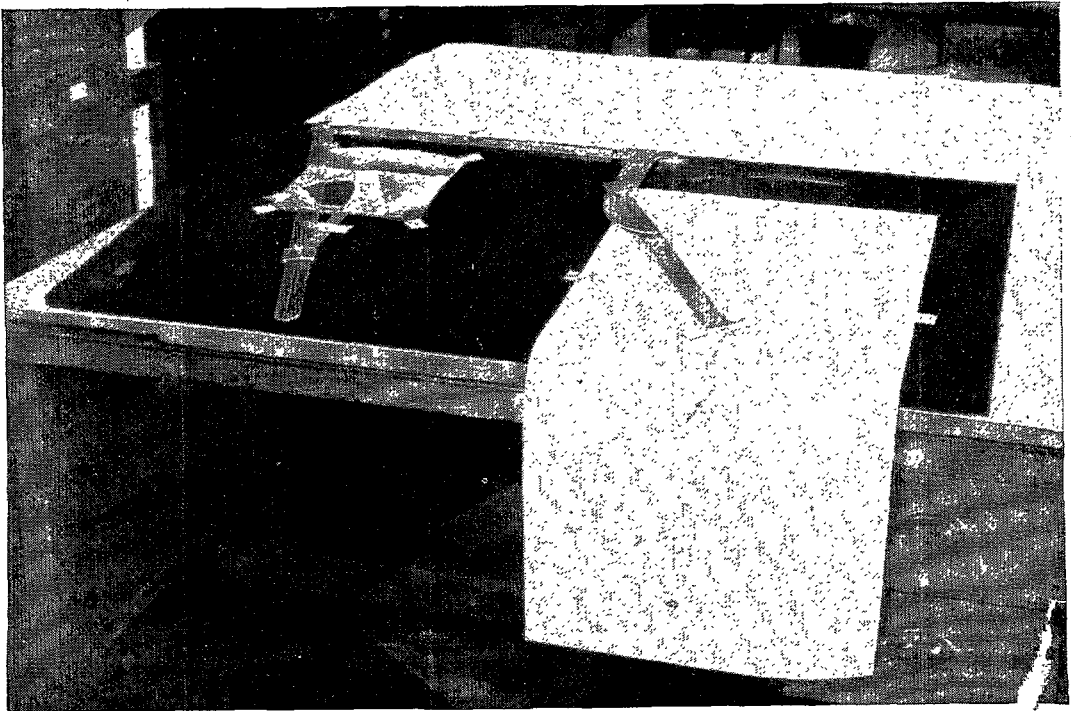

FIGURE 9.7.—The rectoblique plotter.

The instrument consists essentially of a flat board that can be set on a table in a conveniently inclined position, on which are two pivoted adjustable arms—one for the photograph and one for drawing the transformed direction lines on a paper templet—the arms being connected through a horizon bar that slides in a slot. The photograph arm is made of lucite with a hair line on the lower surface, whereas the templet arm is opaque, one edge being used as a straightedge. A photograph is fastened in position relative to its principal point and the horizon line as designated by index lines on the board. The positions of the two pivots are adjusted according to marks on scales that take into account the angle of depression of the oblique photograph and the focal length of the camera. The horizon bar is slid along its slot until the hairline on the photograph arm passes through a given image on the photograph, and a pencil line is drawn along the edge of the templet arm. This is repeated for all the required directions to images, which are usually limited to about eight in number.

The theory of the plotter is discussed in 3732. The use of the horizon bar (artificial horizon), which is not in the same location as the true horizon line of the photograph, is a mechanical expedient that has no effect on the geometry of the problem.

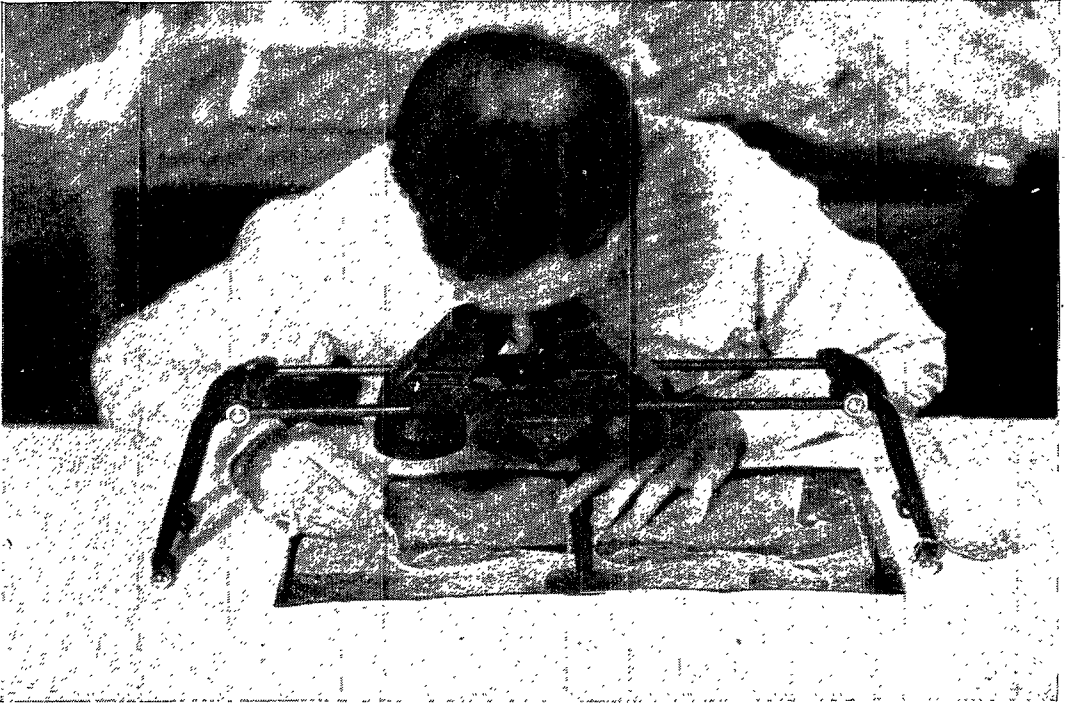

FIGURE 9.8.—The Schneider stereoscope.

### 93. THE SCHNEIDER STEREOSCOPE

The Schneider Stereoscope illustrated in figure 9.8 is a prism binocular stereoscope with a magnification of  $1\frac{1}{2}$  diameters and a field of view about  $3\frac{1}{2}$  inches in diameter. The field of view is flat and clear and the instrument is generally superior to any of the other small stereoscopes now in use in the Bureau. It was manufactured in Germany and is not



purchasable, but the Bureau has about 20 of these instruments which were transferred from the Department of the Army. The viewing section of the stereoscope moves on rails in the X direction. The instrument rests on four polished ball gliding surfaces. Photographs up to 9 by 9 inches in size can be viewed without overlapping, and larger photographs can be viewed by overlapping them as described in 334. The instrument is about 25 inches long, 8 inches high, and 6 inches wide. There is a carrying case for each instrument which is folded in two parts when in the case. It is an excellent portable field stereoscope, but is also used extensively in field offices and field photogrammetric offices, where it can be conveniently equipped with the parallel mechanism shown in figure 1 15.

## 94 REFERENCE BOOKS

The books listed herein have been selected from current publications related to various phases of photogrammetric mapping. The list is not exhaustive, but is limited to books that are available to Coast and Geodetic Survey personnel through the Bureau Library and that are most likely to be of interest and practical use to employees engaged in photogrammetric mapping.

The nomenclature and definitions recommended by the American Society of Photogrammetry are of particular interest to users of this Manual. The definitions were originally published in Volume 8 Number 4 of the magazine "Photogrammetric Engineering" in December 1942 and can still be obtained from the Secretary of the American Society of Photogrammetry in pamphlet form. The definitions were also included in the Manual of Photogrammetry published by the Society. The definitions have recently been revised and will be included in the revised edition of the Manual of Photogrammetry to be published by the American Society of Photogrammetry. The definitions serve as a useful supplement to this Manual but are not accepted for official Bureau use in specific cases where they conflict with the definitions and nomenclature contained in the Bureau's Topographic Manual.

Publications of the Coast and Geodetic Survey are identified by numbers in the left hand column of the following list of books, except for a few unnumbered ones that are identified by asterisks. The numbered Coast and Geodetic Survey publications are either *special* publications or *serial* publications, serial publications are identified by the abbreviated word *Ser* preceding the number.

Several publications of other agencies of the federal government are included in the following list of books and the purchase price of each is indicated. Copies of government publications for unofficial use must be purchased from the Superintendent of Documents, Washington, D. C. at the price indicated in the list, exceptions are one publication that must be purchased from the Navy Department as listed in 944, and a few of the Coast and Geodetic Survey publications indicated by the superior figure 1 that can be obtained free of charge from the Director, Coast and Geodetic Survey, Washington, D. C.

### 941 GROUND SURVEYS

<i>Special Publication No</i>		<i>Price</i>
	American civil engineers' pocket book by T. Merriman	
Ser 584	Azimuths from plane coordinates	05
Ser 624	Computation of traverse by plane coordinates	05
226	Control leveling	05

<i>Special Publication</i>		<i>Price</i>
<i>No</i>		
Ser 583	Control surveys and their uses <sup>1</sup>	
	242 Definitions of terms used in geodetic and other surveys	45
Sci 166	Directions for magnetic measurements	1 00
	8 Formulas and tables for the computation of geodetic positions	40
	129 Geodetic level and rod	05
	227 Horizontal control data <sup>1</sup>	
	143 Hydrographic manual	3 50
	193 Manual of plane-coordinate computation	55
	194 Manual of traverse computation on the Lambert grid	45
	195 Manual of traverse computation on the transverse Mercator grid	50
	239 Manual of geodetic leveling	40
	Manual of instructions for the survey of the public lands of the United States by the Bureau of Land Management	2 50
145	Manual of second and third-order triangulation and traverse	75
247	Manual of geodetic triangulation (to be published in 1950, will include instructions for first-, second-, and third-order triangulation and base-line measurement)	
231	Natural sines and cosines to 8 decimal places	3 00
241	Natural tables for the computation of geodetic positions Clarke Spheroid of 1866 (in press)	
Ser 562	Plane coordinate systems <sup>1</sup>	
	Principles and practices of surveying, elementary surveying Vol I, by C B Breed and G L Hosmer	
	Principles and practices of surveying, higher surveying Vol II by C B Breed and G L Hosmer	
234	Signal building	25
246	Sines, cosines, and tangents to 10 decimal places, 0° to 6° (for Lambert coordinate computation)	20
	Surveying—War Department technical manual, No TM 5-235	1 25
	Surveying tables—War Department technical manual No TM 5-236	40
	*Tables for computation of state plane-coordinates, separate publication available for each state <sup>1</sup>	
Ser 632	The preservation of triangulation station marks <sup>1</sup>	
	Topographic instructions of the U S Geological Survey Department of the Interior, Bulletin 788	1 25
144	Topographic manual (to be superseded by Topographic Manual, Part I when published)	55
Scr 347	Use of Coast and Geodetic Survey data in the survey of farms and other properties	10

## 942 PHOTGRAMMETRY

Advanced surveying and mapping	George D Whitmore
Air photography applied to surveying	C A Hart
Applied photogrammetry	Ralph O Anderson
Elements of photogrammetry	Earl Church and Alfred O Quinn
Fundamentals of optical engineering	Donald Jacobs
Manual of photogrammetry (revised) (in preparation)	American Society of Photogrammetry
Multiplex mapping equipment, TM 5-244, price 25 cents	War Department
Photogrammetric engineering, quarterly publication	American Society of Photogrammetry
Photogrammetry—Bulletins Nos 1 to 17	Syracuse University
Photogrammetry collected lectures and essays	O Von Gruber
Principles and practices of surveying, higher surveying, Vol II	C B Breed and G L Hosmer
Reprint of definitions of photogrammetric terms	American Society of Photogrammetry
The principles of optics	Arthur G Hardy and Fred H Perrin
Trimetrogon mapping including the photoalidade, (forthcoming publication)	U S Air Forces

## 943 CARTOGRAPHY

<i>Special Publication No</i>		<i>Price</i>
205	Cartography	1 00
68	Elements of map projection with applications to map and chart construction	1 25
5	Tables for a polyconic projection of maps	75

## 944 MISCELLANEOUS

\* List of publications of the Coast and Geodetic Survey<sup>1</sup>

Manual of coastal delineation from aerial photographs, by P G McCurdy—sale by Hydrographic Office, Navy Department, Washington D C—H O Publication No 592—price 1 50

Physics of the earth—Vol VII, by National Research Council—(out of print)

Shore processes and shoreline development, by D W Johnson—(out of print)

Suggestions to authors, U S Geological Survey, Department of the Interior—price 20 cents

The Sea, by H A Marmer (out of print)

The Tide, by H A Marmer (out of print)

\* Writing aids<sup>1</sup>

# INDEX

(The bold face numbers in the left hand column are the item numbers accompanying text headings. See preface for explanation of these numbers.)

<b>A</b>		Reference No	Page
Abbreviations	fig 5 45		438
capitalization of	513		319
on map manuscripts	514		320
Symbols and	figs 5 21 to 5 48		414 441
Aberrations of lenses			
cameras	221		61
optics	318		105
Abrams contour finder	61		443
Absolute orientation multiple	631		463
Acceptable arrangement of points for determining the approximate scale of a photograph	fig 3 4		111
Accepted section corner			
definition of	5453Da		388
delineation of	5453Dc		388
symbol	fig 2 12 fig 5 44		388 437
Accessories photographic airplane	23		77
Accommodation of the eye	331		140
Accounting cost	716		477
Accuracy (see also Map accuracy)			
compilation report	7261		493
control			
horizontal and vertical	121 122	2 & 4	4
identification	4114		258
photogrammetric stations	122		4
plotting	415		276
delineation	5411	330-331	4
shoreline	122 15421		4 338
Tolerance equivalents	table 5 1		331
drafting a map manuscript in	51		316
field edit report	727		496
horizontal map	121		2
map	12		2
National standards of	121		2
Coast and Geodetic Survey	122		4
tests			
disposal of records	8236		502
examination in Washington Office	8235		502
field edit report on	727		496
vertical map	121		4
Acetate sheeting cellulose	4131		267
Acuity of the eye	331		141
Adaptation			
of the eye	331		140
To a single photograph tilt determination	3531		197
Additions and corrections review of manuscript	5811		410
Adequacy of			
compilation Field edit report	727		496
control report	725		491
Photography	158		50
report	725		491
Adjoining surveys data from	4144		276
Adjustment of			
horizon line oblique photograph	fig 3 64		247
nine lens camera	2232		70
photograph manuscript delineation	531		328
templates in radial plotting	4243		288
Tilt data to fit control oblique photograph	3735		245
example	3735		248
Administrative assistant and clerical force field office duties	1313		7
Aerial			
Camera lens The	319		106
cameras (see also Cameras aerial)	22		59
Film filing and numbering	8221		498
Negatives inspection and appraisal	8231		500

	Reference No	Page
Aerial—Continued		
Photographic Film	225	73
Color Sensitivity	2251	73
Film speed	2252	73
Grain	2253	73
Selection criteria	2254	74
Photography	2	57
Airplane instruments and accessories		
series	23	77
Cameras and materials	22	59
cost relative	21	57
film characteristics	221	61
filters camera	226	74
Flight planning	25	95
General Instructions	24	88
General statement	21	57
infrared	2264	77
Laboratory processing and records	26	97
lens characteristics	221	61
Aeronautical		
aids report form	713	474
charts reporting new information to	8234	502
Aero Service Corp plotting instrument	61	442
Aerotriangulation	61	444
Aid(s) to navigation		
aeronautical report form	713	474
compilation report	713	493
definition	4611A	309
delineation of	5425P	353
elevations and heights to be shown	5425P	353
field inspection report	724	489
Fixed delineation of	5463A	394
names must agree with Light List	5461	393-394
report form	713	475
review of on manuscript	5811	408
symbols	fig 2 43	436
Air		
Base and interocular distance		
stereoscopy	3331	145
base computation example 1	3242	123
Theodimeter	2333	84
Aircraft photographic	2122 2232	59 72
Airplane(s)		
diff	2334	84
Flight personnel and	231	77
Airplanes in use	2311	77
Flight personnel	2312	79
Instruments and Accessories (see also Instruments)	23	77
Airplanes and flight personnel	231	77
Flight operation	232	79
Instruments for aerial photography		
map	233	81
photographic in use	2311	77
illustration	fig 2 10	78
Airport(s)		
delineation of	5447	377
limits		
delineation of	5454	391
symbol	fig 5 43	436
Plans and charts photographs for	2113	58
Surveys files	8228	500
symbol	fig 5 35	428
Alignment of contours	5432Da	359
Alongshore		
And offshore features	915	523
area(s)		
definition of	5231D 9152	323 524
delineation of from field photographs	542	338
instructions for reviewing manuscript	5811	408
interpretation	3231D	323
Cultural features delineation of	5425	348
Breal waters and Jettes	5425A	348
Bridges over navigable water	5425B	349
Buildings	5425C	349
Canals and ditches	5425D	350
Dams	5425E	350

Alongshore—Continued	Reference No	Page	Apparent—Continued	Reference No	Page
Cultural features—Continued			shore line—Continued		
Dolphins, piling, submerged piling fenders stumps and snags	5425F	350	symbol	fig 5 2°	415
Dry docks floating docks and pilot slips (marine rail ways)	5425G	351	Application		
Ferry slips	5425H	351	photogrammetry to coastal surveys	911	519
Fish stakes fish traps, and duct blinds	5425I	351	Rectifier of the Coast and Geodetic Survey	367	216
Levees dikes, and spoil banks	5425J	351	Graphs of the rectifier settings	3621	219
Obstructions	5425K	351	Appraisal of aerial negatives	8231	500
Overhead and submerged cables and submerged pipe lines	5425L	351	Approximate contours, definition and delineation of	5432Ad	358
Piers and wharves	5425M	352	low water line symbol	fig 5 22	415
Sea Walls and bulkheads	5425N	352	mean high water line symbol	fig 5 22	415
Wrecks	5425O	353	Aqueous humor of the eye	331	139
details compilation report	7261	493	Areal field inspection report of	724	487
features			Arrangements for a mapping project	913	520
definition	9152	524	Assembled spider templet illustration	fig 4 18	301
field inspection report	724	488	Assembling a radial plot with Hand templets	425	289
mutual responsibility of photogrammetric and hydrographic surveys	8433	508	Final radial plot assembly	4253	292
purpose of field inspection	542	338	Illustration	fig 4 14	294
Physical features delineation of	5423	342	Horizontal points not held during the radial plot assembly	4251	290
Bluffs cliffs crevices and scaps	5423A	342	Preliminary radial plot assembly	4252	291
Marine vegetation	5423B	342	Transfer of pass points and radial centers	4254	293
Marsh mangrove and other swamp areas	5423C	343	Slotted templets	4423	306
on a planimetric or topographic manuscript illustration	fig 5 6b	341	Illustration	fig 4 p 1	306
on a shoreline manuscript illustration	fig 5 6a	340	Spider templets	4413	303
Sand gravel sand and gravel mud and boulders	5423D	343	Illustration	fig 4 19	302
Shoals channels and breakers	5423E	344	Assembly of descriptive report	7214	482
Tidal drainage	5423F	344	radial plot with hand templets illustration	fig 4 14	294
Altitude	2332	82	slotted templets illustration	fig 4 21	306
Altitude			spider templets illustration	fig 4 19	302
Scale — and derivation of relations	322	88	Astio compass	232	80
instructions for aerial photography	2412	88	Astronomic point station classified	199	51
Sun — of the illustration	fig 2 11	91	Automatic Pilot	2335	85
instructions for aerial photography	2432	91	rectifier	36	201
Amount of Relief displacement	3232	115	Average scale of photograph scale factor formula example table 1	412	264-265
Tilt displacement	3432	164	Awash, rocks definition	5424A	345
illustration	fig 3 31	165	Axix of tilt	341	158
Amusement park symbol	fig 5 35	428	Azimuth line(s)		
Anaglyph stereoscopy	332	142	carrying an — forward with points		
Analytic geometry of the tilted aerial photograph illustration	fig 3 36	175	normal to the azimuth line	fig 4 11	286
plane —	327	136	pricked in the direction of the azimuth line	423	286
Problems involving tilt	346	174	Nine lens photographs — on	423	286
Coordinate transformation	3462	177	Photographs — on	4113	256
Relations of tilt swing nadir point	3463	179	radial plotting	4113	256
To find the exact Flying height	3464	182	theory	3254	130
Ground distance	3461	174	liner(s)	1419	22
Problems no tilt To find the exact Flying height	3272	138	mark	6244d	459
Ground distance	3271	137	definition	4611A	309
solid — of the aerial photograph illustration	347	183	delineation of	5463C	394
Anderson method of tilt determination	352	192	Points radial plotting	4611C	310
illustration	fig 3 41	193	of a line	4143	275
scale point construction illustration	fig 3 35	172	point, symbol	fig 5 41	434
Angle between two directed lines example 1	347	186	used as control in radial plotting	1591	53
dihedral definition	3251	127			
projected onto an inclined plane example 2	3424	163	<b>B</b>		
Angular field of a lens	319	106	Bank spoil — delineation of	5425J	351
flight planning and	3241	118	delineation of contours about	5432Dd	360
Annual statistical report	717	478	Ball park delineation of	5448B	378
Aperture aerial camera lens	221	61	symbol	fig 5 30	428
Apparent horizon, dip of	table 3 2	236	Base rock s alongshore definition of	5424A	345
shoreline definition	5421	339	Par shoreline interpretation	5231	325
			Barometer, aircraft altimeter	2332	82
			Base Grid	4134	269
			hand construction	4133	268
			material for (See Plastic sheeting)		
			length		
			photographic	3241	119
				3242	122

Base—Continued	Reference No	Page
length—Continued		
stereoscopic	3331	145
width, of two photographs		
<i>for formulas</i>	3242A-H	122-
Line Public Land Surveys	5453C	384
sheets for Reading plotters	6244J	460
width photographic	3242	122
Bausch and Lomb Optical Co	2222	65
Beam compass		
description of a	1418	21
<i>illustration of use of</i>	fig 1 6	21
Beechcraft SNB photographic airplane	2311	77
Benck Mail (s)	5466	395
classification and delineation	5466	395
lettering elevations on manuscript	54	329
<i>symbols</i>		
monumented	fig 5 14	395
monumented vertical angle	fig 5 15	395
non monumented	fig 5 16	396
tidal	fig 5 17	396
those to be mapped	5466	395
vertical control classification	159	51
Bisector of tilt angle	3421	159
Blind duct		
delineation of	5425I	351
<i>symbol</i>	fig 5 28	421
Blue line print	852	512
Blue print	884	518
Bluff (s)		
Cliffs, crevices, and scarps delineation	5423A	342
<i>symbol</i>	fig 5 40	433
Blunders in photogrammetry	912	520
Bog		
cranberry, delineation of	5431C	355
<i>symbol</i>	fig 5 36	429
Bombsight for aerial photography	2232	72
	232	30
	2336	85
Books reference — list of	941	535
Borrow pit <i>symbol</i>	fig 5 35	428
Boulder (s)		
Areas contour delineation	5432Dg	361
delineation	5423D	343
<i>symbol</i>	fig 5 23	416
Boundary (ies)		
definitions and delineation of	545	378
field data on	545	379
field inspection report	724	489
instructions for reviewing map manuscript	5811-31	409
limit lines <i>symbols</i>	fig 5 43	436
limits of certain features not to be confused with	5454	391
Line (s)		
definition	545	378
review of — on map manuscript	5811-31	409
monument		
definition	545	379
<i>symbols</i>	fig 5 44	437
reports	714	476
and data receipt and distribution by Washington Office	8232	501
subdivisions of incorporated places not to be mapped	5451	379
<i>symbols</i>	fig 5 44	437
Braided Stream (s)		
delineation of	5431Ad	355
<i>symbol</i>	fig 5 25	418
Breakers		
delineation of	5423E	344
shoreline interpretation	5231D	325
<i>symbol</i>	fig 5 23	416
Breakwater (s)		
and Jetties delineation of	5425A	348
<i>symbol</i>	fig 5 28	421
Bridge (s)		
Book	713	475
clearances and tide corrections	5473	399
data reports	713	475
delineation of — alongshore	5425B	349
delineation of contours about	5432Df	361
field inspection data for	5425B	349
names on map manuscript	5416C	334
Other than over navigable waters		
viaducts overpasses and underpasses	5443	370
Over navigable water, delineation of	5425B	349
review of — on map manuscript	5411-15	408
<i>symbols</i>	fig 5 29	422

Bridge (s)—Continued	Reference No	Page
tide corrections for — clearances	5473	397
viaducts etc		
definitions	5443	370
delineation	5443A	370
Bridging		
analytic	3534C	198
horizontal — for multiplex control	1593	54
multiplex	631	463
radial plot extension	3255	130
with crossflights to control intermediate multiplex strips		
<i>fig</i>	1 22	55
stereoscopic plotting instruments	61	444
Brief history of public land surveys, a	5453B	382
Brock and Weymouth plotting instrument	61	442
B-17 photographic airplane	2311	77
Building (s)		
classification of	5446	372
delineation of	5446A	373
alongshore	5425C	349
class 1	5446B	374
class 2	5446C	374
names of landmarks	5416G	335
runs	5446E	375
schools and churches	5446D	375
urban areas	5446F	375
within control symbols	5446I	373
field classification sometimes delayed until field edit	5446	372
field inspection of	5446	372
landmark — names on map manuscript	5416G	335
names of — on map manuscript	5416	334
public — names of on map manuscript	5416F	335
review of — on map manuscript	5811-28	409
runs delineation of	5446E	375
schools and churches delineation of	5446D	375
<i>symbols</i>	fig 5 34	427
urban areas	5446F	375
delineation in	5232B	326
interpretation		
Bull head		
delineation of	5425N	352
<i>symbol</i>	fig 5 28	421

C

Cabinets for a photogrammetric office	1425	25
Cable crossing		
delineation of overhead and sub merged	5425L	351
<i>symbols</i>	fig 5 30	423
Calibration		
nine lens camera	2232	70
templet	4242	287
<i>illustration</i>	fig 1 12	287
Camera (s) aerial mapping	22	59
adjustment of nine lens	2232	70
Fairchild cartographic	2222	59
<i>illustration</i>	fig 2 3	64
inner cone of — <i>illustration</i>	fig 2 4	65
F-51	2223	66
K-17	2221	63
<i>illustration</i>	fig 2 2	63
K-20	2224	68
<i>illustration</i>	fig 2 5	66
<i>fig</i>	221	61
lenses for	319	106
Maintenance	244	93
Special handling and operation of the nine lens camera	2441	93
Material — and	22	59
Aerial photographic film	225	73
Filters for Aerial photography	226	74
Lens Requirements	221	61
Nine lens camera	223	67
Single lens cameras	222	62
Trimetrogon camera	224	72
Nine lens — The	223	67
coverage data of	table 2 1	67
<i>diagram of</i>	fig 2 7	70
<i>illustrations</i>		
of	fig 2 6	68
of a nine lens negative	fig 2 8	71
of a nine lens photograph	fig 4 1	255

	Reference No	Page		Reference No	Page
Camera(s)—Continued					
Oblique photography, ———	2224	66	Clearing line <i>symbol</i> ———	<i>fig</i> 5 30	423
operation of ———	2441	93	Cliffs, delineation of ———	5423A	342
Single lens ———	222	62	Cloverleaf, <i>symbol</i> ———	<i>fig</i> 5 32	425
selection of ——— for photography	251	95	Coastal		
Canadian (perspective) grid	375	252	mapping		
<i>numerical example</i> ———	375	---	photographs for ———	2111	57
Canal(s)			procedures ———	913	520
Ditches ——— and alongshore de			Surveys use of horizontal photo		
lineation ———	5425D	350	graphs ———	3714	230
navigable ——— <i>symbol</i> ———	<i>fig</i> 5 22	415	Coast and Geodetic Survey		
<i>symbol</i> ———	<i>fig</i> 5 25	418	freehand lettering for use on map		
Capitalization ———	513	319	manuscripts <i>illustration</i> ———	<i>fig</i> 5 1	319
Cardboard templates ( <i>see also</i> Slotted			Use of aerial photographs ———	211	57
templates) ———	442	305	Airport plans and charts ———	2113	58
Care of Instruments ———	141	13	Coastal mapping ———	2111	57
Carline (interurban railway) delinea			Nautical chart revision ———	2112	58
tion of ———	5442	370	Reconnaissance ———	2114	58
<i>symbol</i> ———	<i>fig</i> 5 33	426	Coast Guard photographic airplane		
Carrying an azimuth line forward			<i>illustration</i> ———	<i>fig</i> 2 10	78
with points (radial plot			crew ———	23	77
ting) ———	423	286	Coast Pilot report ———	713	475
— normal to the azimuth line			Code numbers		
<i>illustration</i> ———	<i>fig</i> 4 11	286	photographs ———	156	47
— pricked in the direction of the			level to data stamped on single		
azimuth line <i>illustration</i> ———	<i>fig</i> 4 10	286	lens aerial photographs		
<i>illustration</i> ———	<i>fig</i> 4 10	286	<i>illustration</i> ———	<i>fig</i> 1 19	46
Cartographic			projects ———	15	30
Camera ———	2222	64	Color		
<i>illustration</i> ———	<i>fig</i> 2 3	64	correction lens ———	221	62
inner cone <i>illustration</i> ———	<i>fig</i> 2 4	65	film aerial photographic ———	2254	74
Comparison of map manuscript			filters aerial photographic ———	226	74
office review ———	843	506	Sensitivity of aerial photographic		
Hydrographic surveys ———	8433	507	film ———	2251	73
Maps of other agencies ———	8432	506	separation for lithographic repro		
Nautical charts ———	8434	508	duction ———	852	512
Topographic surveys ———	8431	506	(spectral) distribution of daylight	2261	75
reference books ———	943	537	<i>diagram</i> ———	<i>fig</i> 2 9	75
Catalina flying boat PBV-5 ———	2311	77	Combined		
Catalog of published maps ———	871	516	deformations in stereoscopy ———	3338	150
Cellulose acetate ( <i>see also</i> Plastic			operations in hydrographic survey		
sheeting) ———	4131	267	ing ———	911	519
Cemetery (ies)			Comparison of		
delineation of ———	5448A	378	map manuscript in		
Fairgrounds golf courses race			compilation report with existing		
tracks ball park's stadium			maps and nautical charts	7261	494
iums zoos etc delineation			review with		
of ———	5448	378	Hydrographic surveys ———	8433	507
limits			Maps of other agencies ———	8432	506
delineation of ———	5454	391	Nautical charts ———	8434	508
<i>symbol</i> ———	<i>fig</i> 5 43	436	Topographic surveys ———	8431	506
<i>symbols</i> ———	<i>fig</i> 5 35	428	Photograph with a map ———	321	108
Center of perspective ———	341	157	Compass		
Channel			aerial photography ———	2331	81
definition and delineation ———	5423E	344	astro compass ———	232	80
line <i>symbol</i> ———	<i>fig</i> 5 22	415	flux gate ———	2331	81
Character of Drafting ———	51	316	beam description of ———	1418	21
Inks ———	512	318	<i>illustration</i> ———	<i>fig</i> 1 6	21
Lettering ———	513	319	Compilation of map manuscript ( <i>see</i>		
Symbols and Abbreviations ———	514	320	<i>also</i> Delineation manu		
Use of Instruments ———	511	317	script) ———	5	316
Characteristics of			accuracy ———	5411	330
aerial photographic film ———	225	73	Tolerance equivalents at various		
Photographic detail ———	523	322	scales ———	<i>table</i> 5 1	381
Cultural features ———	5232	325	graphic ———	5	316
Physical features ———	5231	322	drafting ———	51	316
Chart			853	513	
field photograph ——— <i>illustration</i>			Instructions for ———	1517	34
letter in nautical revision ———	<i>fig</i> 1 20	48	Report ———	726	491
comparison with nautical ———	882	517	comparison with existing maps		
ing review ———	8434	508	and nautical charts ———	7261	492
Organization ———	131	6	Notes keeping for report ———	5418	335
<i>diagram</i> ———	<i>fig</i> 1 1	6	Office review form ———	7262	496
Checked spot elevations delineation			Preparation of ———	7261	492
of ———	5467	396	review of ———	5811	406
Cheeking photographs radial plotting	4111	254	Complete space solutions of the aerial		
Chromatic aberration ———	221	62	photograph		
Chronological			analytic The ———	3534	197
order of party operations ———	152	36	Control extension ———	3534C	198
outline of field party and photo			Space intersection ———	3534A	198
grammetric office opera			with ground elevations known	3534B	198
tions for photographic			mapping ———	<i>table</i> 1 3	36
mapping ———	<i>table</i> 1 3	36	by stereoscopic plotting instruments	61	442
Church(es)			Completion		
interpretation ———	5232B	326	Map manuscript ———	59	411
names on map manuscript ———	5416A	334	outline of procedures ———	811	497
Schools and ———, delineation of ———	5446D	375	radial plot ———	46	307
<i>symbol</i> ———	<i>fig</i> 5 34	427	Washington Office Review and	8	497
Cities interpretation ———	5232B	326	Component tilt angles relations of		
Claims public land surveys ———	5453Cf	386	<i>illustration</i> ———	<i>fig</i> 3 49	214
Classification of control ( <i>see also</i>			near vertical photograph ———	3462	177
Control classification) ———	159	51	<i>numerical example</i> ———	366	215
<i>diagram</i> ———	<i>table</i> 1 4	51	rectification ———	366	213
Classified Data ———	155	45			

	Reference No	Page		Reference No	Page
Condition			Control—Continued		
in taking equally tilted photo			ground	159	51
graphs stereoscopy <i>illustration</i>	<i>fig 3 21</i>	149	horizontal		
of Sharp Definition rectification	361	201	stations points	159	51
Cones of the eye	331	140	field inspection report	724	488
Confidential classified data	155	45	identification		
Conjugate			card	4114	259
centers in radial plotting	{3254	130	<i>illustration</i>	<i>fig 4 2</i>	259
foci law	{4113	256	radial plotting	4251	290
formula	315	103	indexes		
of the nine lens trans forming printer <i>illustration</i>	<i>equation 310 C</i>	103	Horizontal	1537	41
Construction of			Vertical	1538	41
perspective grid	375	250	pass point	159	51
<i>illustration</i>	<i>fig 3 6 5</i>	250	photo elevation point	159	51
Slotted templates	4422	305	photogrammetric station point	159	51
Spide templates	4412	302	photo hydro station point	159	51
Contemporary maps surveys			photo (topo) station point	159	51
delineation of junctions	5414	333	planetable station point	159	51
review of map manuscript	{8433	507	Planning	159	51
review of map manuscript	{8471	511	horizontal control requirements	159	50
Contents of descriptive report sequence of	721	481	for		
Contour (s)			Hand templet radial plots	1591	52
Alignment of	5432Da	359	Mechanical templet radial plots	1592	54
Approximate	5432B	358	Multiplex bridging	1593	54
Bridges and	5432Df	361	vertical control requirements for		
Cuts and fills	5432De	361	Contouring with the Reading		
definition of	5432A	357	plotter	1595	56
delineation of	5432A	357	Multiplex contouring	1595	56
Depressions	5432Dc	360	Planetable contouring on photographs	1594	55
ditches and levees special treatment of	5432Dd	360	plotting — points		
drainage and compilation report	7261	493	by Angle and distance	4154	270
edit of in photogrammetric office for accuracy and expression	5432D	359	by Dms and dps	4152	277
field			<i>illustration</i>	<i>fig 4 6</i>	277
edit of contours	5432D	359	by Transfer	4155	280
inspection report	724	488	on Base grids	416	280
finder Abrams	61	442	on Projections	415	276
Form lines	5432C	358	point		
Gravel sand etc and	5432G	361	classification of		
importance of tops and saddles	5432Db	360	distinction between — and station	159	50
Index	5432Aa	357	symbols — <i>figs 5 41 and 5 42</i>	434	435
instructions for drawing	1516	34	Reading plotters for the	6243	457
Intermediate	5432Ab	357	Records	1542	43
intervals	5432A	357	Reports and	711	472
for multiplex formula	632	465	transmittal of geodetic		
Levees and spoil banks	5432Dd	360	Office directly to Washington	8232	501
review of — on map manuscript			recoverable definition requirements	159	50
planetable	5811-22	409	horizontal — for		
photogrammetric	5811-23	409	Radial plotting with hand		
in general	5811-24	409	templates	1591	52
Sand dunes and	5432Dh	361	Radial plotting with mechanical templates	1592	54
Special forms of	5432D	359	Multiplex bridging	1593	54
Supplementary	5432Ac	358	vertical — for		
symbols	<i>fig 5 3 8</i>	431	Multiplex contouring	1595	56
Control			Planetable contouring on photographs	1594	55
adequacy report	725	491	Reading plotter contouring with the	1596	56
astronomic station point	159	51	spot elevation point	159	51
bench mark point	159	51	station		
classification of	159	51	classification	159	51
<i>diagram</i>	<i>table 1 4</i>	51	data		
compilation report	7261	492	card M-2388-12	4141	273
for future surveys	7261	493	card <i>illustration</i>	<i>fig 4 5</i>	273
data			Plotting by coordinates	4142	275
card from M-2388-12	414	273	Plotting by dms and dps	4141	273
<i>illustration</i>	<i>fig 4 5</i>	273	Plotting substitute stations	4143	275
radial plotting	414	273	Plotting from adjoining photogrammetric surveys	4144	276
source material	154	42	distinction between — and point	159	50
definitions	159	52	identification card	4114	259
Delineation of	546	392	<i>illustration</i>	<i>fig 4 2</i>	259
Bench marks	5466	395	instructions for reviewing on map manuscript	5811	406
buildings inside control station			substitute station point	159	51
symbols	5446A1	374	temporary definition of	159	52
Horizontal stations of			triangulation	159	51
Third order or higher accuracy	5461	392	types used in radial plotting	415	276
Less than third order accuracy	5462	393	vertical	159	51
Photo hydro stations	5464	394	field inspection report	724	487
Photo (topo) stations	5463	393	Convergence of the eyes	331	141
Spot elevations	5467	396	Cook plotter	61	443
Substitute stations	5465	395	Coordinate(s)		
detail point	159	51	plotting control by	4142	275
extension			State — system	413	266
analytic	3534C	198	Transformation analytic	3462	177
instrumental	61	442	<i>illustration</i>	<i>fig 3 3 7</i>	177
radial plotting	3255	130			





	Reference No	Page
Accuracy of — (see also Map accuracy)	5411	330
tolerance equivalents — table	5411	331
adjustments between detail points	531	328
Airports	5447	377
Alongshore areas — of	542	338
Cultural features	5425	348
details from field photograph	542	338
Low water line	5422	341
Physical features	5423	342
Reefs and ledges	5424	345
Shoreline (mean high water line)	5421	338
Within control symbols	5426	353
Boundaries	545	378
Limits of airports cemeteries		
pails etc	5454	391
Political	5451	379
Public land surveys	5453	381
Reservation	5452	381
Bridges other than over navigable waters		
viaducts over	5443	370
passes and underpasses	5446	372
Buildings	5446A	373
along a road	5446A	373
illustration — fig	5 9	373
Class I	5446B	374
Class II	5446C	374
Churches and schools	5446D	375
Ruins	5446E	375
Urban areas	5446F	375
Cemeteries		
fairgrounds golf courses, race tracks ball parks stadiums zoos etc	5448	378
colors of ink to use	54	329
compilation report, notes on	5418	358
contours	7261	492
Control — of	5432A	357
Bench marks	546	392
Photo hydro stations	5466	395
Photo (topo) stations	5464	394
Recoverable horizontal control stations of	5463	393
Less than third order accuracy	5462	393
Third order or higher accuracy	5461	392
spot elevations	5467	396
Substitute stations	5465	395
Cultural features — of	544	366
Airports	5447	377
Bridges other than over navigable waters		
viaducts overpasses and underpasses	5443	370
Buildings (see also Buildings)	5446	372
Cemeteries		
fairgrounds golf courses race tracks ball parks stadiums zoos etc	5448	378
Power lines telephone lines and telegraph lines	5444	371
Railroads and carlines	5442	369
Stone walls stone fences fences hedges, and crop lines	5445	371
detail		
points location of	531	328
within control symbols	5426	353
Displacement of map features	5413	332
fences	5445	371
field photographs — from	542	338
foreshore area	5423D	344
General statement about	541	329
Geographic names	5415	353
Junctions	5414	353
Land lines public land surveys	5423Dd	389
lettering of land and water features	54	329
line widths	541	330
Low water line	5422	341
Marking on Photographs	5412	351
methods description of	53	326
Names of features	5416	334
Natural ground cover	5433	363
omission of irrelevant details	541	329
orientation of photographs for	531	328
and adjustment illustration fig	5 3	327
personnel qualifications and training for	5	316
Physical features	543	353
Natural ground cover	5433	363
Planimetric manuscripts	543a	353
Relief	5432	357
Shoreline manuscripts	543b	353
Topographic manuscripts	543c	353
Water features	5431	353

	Reference No	Page
Physical features—Continued		
Placement of lettering	5417	336
Planimetric manuscript — of	543a	353
Power lines telephone lines and telegraph lines	5444	371
preparation of		
Manuscript for filing	548	400
photographs for delineation	5412	331
projectors use of in	532	328
Railroads and carlines	5442	369
relief		
Delineation of —	5432	357
displacement formula	462	313
review of	5811	406
Roads and trails	5441	366
Reefs and ledges	5424	345
Ruins	5446E	375
Section corners and township corners	5453Dc	388
Shoreline (mean high water line)	5421	338
Stone walls stone fences fences hedges and crop lines	5445	371
Tide collections	547	397
Topographic manuscripts — of	543c	353
Township corners	5453Dc	388
Urban areas	5446F	375
use of projectors	532	328
Water features	5431	353
widths of features	541	330
Within control symbols	5426	353
Depression		
contour delineation	5432Dc	360
illustration	fig 3 38	431
shoreline at different distances from the camera — of the	3715	232
formula	equation 3715D	234
tables	table 3 4	237
Depth of focus multiplex	632	465
Derivation of formulas rectification	364	206
Description of the nine lens camera	2232	70
Descriptive report	72	479
Assembly of	7214	482
Compilation report	726	491
Copies required	7212	482
cover form 504	722	483
illustration	fig 7 1	483
cross references	72	479
Data record	723	484
disposal of	8234	502
Field		
Edit report	727	496
Inspection report	724	486
filing	8224	499
instructions for preparing general numbers and arrangement of side headings	72	479
Pagination	7213	482
Photogrammetric plot report	725	490
Preface	7232	486
Progress sketch included in	7231	486
radial plot report	725	490
Responsibility signatures and	7211	481
review	5811-37	410
583	411	
721	505	
78471	510	
721	481	
842	506	
Washington Office files	8224	499
Descriptive terms	513	320
Detail point(s) radial plotting	46	308
classification as control	159	51
locating — on a photograph	531	328
marling	531	328
number and arrangement of		
(see also Delineation)	531	328
review of — of map manuscript	5811-1	408
selection of	462	312
531	328	
illustration	fig 4 22	312
symbol	fig 3 42	432
Determination of		
Average scale of photographs	412	262
Tilt of a photograph		
near vertical	35	188
high oblique	3731	237
Devil plotter (footnote)	61	442
Diagram of		
nine lens camera	fig 2 7	70
township illustrating method of numbering sections	fig 5 10a	383
transforming printer	fig 6 1	447



	Reference No	Page
Drift airplane		
angle bombsight	2336	85
sight	2334	84
Dry docks floating docks and patent ships (marine railways)		
delineation	5425G	351
<i>symbol</i>	fig 5 27	420
Duck blind delineation	5425I	351
<i>symbol</i>	fig 5 23	421
Dunes sand delineation of contours		
about	5432Dh	361
<i>symbol</i>	fig 5 40	433
Duration of minimum solar altitude diagram	fig 2 11	91
Duties of photogrammetric sections	131	5

E

Edit		
map manuscript ( <i>see also</i> Review)	58	405
smooth drafting proof	581	405
<i>symbol</i>	557	514
Effect of eye base not being parallel to azimuth line	<i>illustration</i>	fig 3 20
tilt		149
relief on radial lines — and	<i>illustration</i>	fig 3 32
Scale — on	344	169
Rate of scale change due to tilt	3441	170
Scale point the	3442	172
Electric power transmission lines		
delineation of	5444	371
interpretation of	5232A	326
<i>symbol</i>	fig 5 30	327
Elements of orientation	347	187
rectification	36	200
<i>illustration</i>	fig 3 42	200
Elevation(s) camera — of ( <i>see</i> Flying height)		
highest for which there is minimum side lap	<i>formula</i>	3242N
<i>illustration</i>	equation	3242N
photogrammetric determination of		126
corrections for curvature and refraction	372	234
in feet	table 3 1	235
in meters	table 3 2	235
horizontal photographs	3713	230
<i>example</i>	3714	231
instrumentally	6	442
maximum difference for a given overlap	3242	126
<i>example 5</i>	3242	126
Oblique photographs	3734	244
parallax		
absolute formulas <i>examples</i>	3261	132
difference formulas <i>examples</i>	3262	134
generator mechanism Reading plotter	<i>illustration</i>	fig 6 4
relief displacement <i>example 2</i>	3232	117
tilt effect of	345	178
referred to mean high water		
shown in parenthesis when referred to MHW	5424A	345
spot definition of delineation of	5432E	361
Empirical relations rectification	365	218
End lap aerial photography ( <i>see</i> Forward lap)		
definition	3242	121
instructions	2421	90
intervalometer	2338	87
enlargement ratio	3241	118
Equations		
line in space — of a <i>example 5</i>	347	186
rectification	36	200
transformation	347	183
Equipment		
Instruments for a photogrammetric office — and	14	13
Furniture	142	22
Instruments	141	13
Ratio reflecting projector	143	26
Stereoscopes	144	27
photographic miscellaneous aerial	2339	87
Equivalent vertical photograph definition	341	158

	Reference No	Page
Errors in photogrammetry	912	520
Establishing photogrammetric points for mapping with the Peading plotter	464	315
<i>symbol</i>	6244	458
Dstereo corrector altimetric plotter	61	443
Evaporator salt delineation of	5431C	355
<i>symbol</i>	fig 5 36	429
Evergreen trees <i>symbol</i>	fig 5 37	430
Exact analytic computations		
tilted photograph	346	174
flying height <i>example</i>	3464	182
horizontal ground distance <i>example</i>	3461	176
vertical photograph	327	196
flying height <i>example</i>	3272	139
horizontal ground distance <i>example</i>	3271	138
Examination of proof copy field edit report	727	496
Example of combined tilt and relief displacements <i>illustration</i>	fig 3 33	169
scale point method of tilt determination	352	192
<i>illustration</i>	fig 3 41	193
Excavation <i>symbol</i>	fig 5 35	428
Existing maps comparison with compilation report	7261	494
Exposure interval aerial photography distance on	3242	124
ground <i>example 1</i>	3242	124
map <i>example 2</i>	3242	124
<i>formula</i>	equation 2 22K	124
intervalometer	2338	87
time in seconds <i>example 3</i>	3242	125
Extension of photogrammetric control radial plotting	3255	130
stereoscopic plotting	61	444
multiplex	631	463
Dive base stereoscopy	3331	145
fatigue		
in using a magnifying glass	331	151
parallax and	334	142
human — the	331	139
<i>diagram</i>	fig 3 13	140

F

Factor scale — <i>formula</i>	4114	260
<i>table</i>	table 4 1	265
Factories interpretation	5232B	326
Fanchild		
aerial camera	222	62
cartographic camera	2222	64
<i>illustration</i>	fig 2 3	64
inner cone <i>illustration</i>	fig 2 4	65
stereocomp u graph	61	443
stereoscope F-71	1444	29
Fan grounds stridiums etc delineation of	5448B	378
<i>symbol</i>	fig 5 35	428
Fatigue of the eyes	331	141
Features map delineation of		
cultural alongshore	5425	348
physical	543	353
alongshore	5423	342
Miscellaneous	5431H	356
Federal highway numbers <i>symbol</i>	fig 5 32	425
Fences delineation of	5445	371
interpretation of	5232 A	326
Fenders delineation of	5425F	350
Ferry slip delineation of	5425H	361
<i>symbol</i>	fig 5 29	422
F-51 Fanchild aerial camera	2223	66
Fiducial marks		
definition	341	157
special single lens camera	431	296
Field		
data stamp for aerial photographs	1572	49
<i>illustration</i>	fig 1 21	42
edit		
completion of map manuscript		
accuracy tests contours planimetry	5911	412

Field—Continued edit—Continued	Reference No	Page	Reference No	Page
corrections to map manuscript	5912	418	Flatness of field of a lens	221
color of ink to use	5913	413	Flicker	
examination of data in Washing ton Office	5914	413	sensitivity of the eye	331
description of	8235	502	stereoscopy	332
field inspection work not repeated	8235	502	Flight	
Instructions for	5911	412	height ( <i>see</i> Flying height)	
instructions for corrections	1518	34	lines	252
preparation of data for	8235	502	placement photography instruc tions	2411
preparation of data	83	504	spacing formula for	252
sheets in Washington Office files	8223	498	Map	252
special instructions for	83	504	map	3242
records disposal of	8235	502	Operation	232
Report	727	496	Personnel	3212
inspection			Planning	324
alongshore areas	542	338	base length width	3241
Interpretation of photographs	521	321	camera selection	3242
Instructions for project	1513	33	double photography	3241
Notes rocks reefs ledges	542AB	346	enlargement ratio	3241
Photographs review of	5811-38	410	exposure interval	
review of	5811-38	410	ground distance normal ter rain	
Washington Office	8233	502	example 1	123
purpose of	542	338	ground distance, rugged ter rain	3242
records forward directly to Washington Office when	8232	501	example 6	126
report instructions for	724	486	map distance example 2	124
	221	61	time in seconds example 3	125
lens, — of view of a	319	106	field of view of camera	3241
	3241	118	formulas equations 3242A-N	122- 126
office photogrammetric			Flying height selection	3241
Officer in charge	1311	6	forward lap	3242
Operation	13	5	graphic compilation — fo	3241
Organization	131	5	image	
party coordination	152	35	definition example 4	3242
photograph			movement example 4	125
chart illustration	fig 1 20	48	mine lens camera for	3241
definition	1572	48	overlap normal and rugged ter rain	3242
delineation of alongshore fea tures from	542	338	planimetric mapping — fo	119
disposal	8233	502	ratio of enlargement	3241
inking on in the office	5412	331	side lap	3242
preparation	5472	48	spacing of flight lines	
survey(s)			formula fo	252
Photogrammetric	13	5	normal and rough terrain	3242
public land surveys	5453D6	388	Theory of	324
records receipt examination and distribution by Wash ington Office	8232	501	topographic mapping — fo	117
Files division of photogrammetry Washington Office			wide angle camera, effect of	3241
Aerial film	822	498	ultra	118
Airport surveys	8221	498	Floating	
Descriptive reports	8228	500	dock	
Field edit sheets, map manuscripts and	8224	499	delineation of	5425G
Form 524 descriptions station iden tification cards and	8225	499	symbol	fig 5 27
Indexes of photographs and maps	8227	500	Marl	335
Map manuscripts and field edit sheets	8223	498	principle of illustration	fig 3 26
overhauling after completion of project	8238	503	Flux gate compass	2331
Photographs	8222	498	Flying	
Project	8226	499	Aerial photography — fo	241
Till			instructions	241
delineation of contours about	5432De	361	Placement of flight lines	2411
symbol	fig 5 39	432	Scale and altitude	2412
Film aerial photographic			Tilt	2413
characteristics	225	73	Tuns	2414
Color sensitivity	2251	73	height	
Gain	2253	73	computation approximate	3222
Selection criteria	2254	74	computation exact	
Speed	2252	73	Tilted photograph	3464
Filters for aerial photography	226	74	Vertical photograph	3272
Factors for exposure	2263	76	scale — and	322
Infrared for	2264	77	selection of	3241
Light and color	2261	75	F number definition and example	319
Types of	2262	76	Focal length	
Final radial plot assembly	4253	292	computation of example 2	315
for a map manuscript illustra tion	fig 4 14	294	definition of	104
Firebreak symbol	fig 5 30	423	photograph of	341
Fish stales fish traps and duck blinds delineation of	5425I	351	Rectifier lens — of a	362
symbols	fig 5 28	421	illustration	fig 3 44
Fixed aids to navigation			scale of a photograph relation to	322
definition radial plotting	4611A	309	Focus	
delineation of	5463A	394	formula for sharp — equation	310 C
symbol	fig 5 43	436	lens law for sharp	315
			rectification for	361
			Foot scale illustration	fig 1 4
			Fords symbol	fig 5 29
			Footshole	
			definition of	5423
			delineation of areas	5423D
			interpretation	5231D
			symbolization	5423

	Reference No	Page		Reference No	Page	
Form(s)			Geometry—Continued			
Lines			Scale focal length	322	108	
definition and delineation of	5432C	358	Tilt displacement	343	164	
<i>symbol</i>	fig 5 38	431	tilted photograph	34	157	
office and field	71	470	Vertical photograph	32	107	
form 504 descriptive report cover	722	433	Gambal mechanism	366	213	
<i>illustration</i>	fig 7 1	433	<i>illustration</i>	fig 3 48	214	
form 524 topographic station	4611A	309	Glacier			
filing	3225	499	moraine <i>symbol</i>	fig 5 26	419	
form 567 landmarks	4611B	309	Permanent snow or ice fields			
form M-2226-12 identification			and delineation of	5431F	356	
caid	724	488	<i>symbol</i>	fig 5 26	419	
form M-2388-12 control station	724	488	Glade land <i>symbol</i>	fig 5 06	429	
data	725	491	Glass negative of map manuscript	852	513	
<i>illustration</i>	fig 4 5	273	Goerz Daggar lens	622	448	
form M-2617-12, tide computa			Golf course			
tion	5471	398	delineation of	5448B	378	
<i>illustration</i>	fig 5 18	398	<i>symbol</i>	fig 5 35	428	
form T-1	733	485	Grade crossing <i>symbol</i>	fig 5 32	425	
<i>illustration</i>	fig 7 2	485	Grain in photographic film	2253	73	
form T-2	5811	406	Graph			
<i>illustration</i>	fig 5 20	406	for determining the distance from			
Formulas for rectification	36	200	the principal point to the			
Forwarding manuscripts and records	715	476	midpoint	fig 4 7	283	
Forward lap	3242	121	rectification	3671	219	
Foul areas			angular settings	fig 3 53	221	
delineation of	5424B	416	corrections to the y settings	fig 3 54	222	
<i>symbols</i>	fig 5 23	140	easel linear settings	fig 5 52	220	
Fovea centrals of the eye	331	140	lens settings	fig 3 51	220	
F-71 Fanchild stereoscope	1444	29	nomogram for determining the			
<i>illustration</i>	fig 1 16	30	position of nadu point			
Full size detail of projection and			after rectification	fig 3 55	223	
grids on a map manu-			relief displacement computer	fig 3 50	217	
script <i>illustration</i>	fig 4 4b	272	Graphic			
Function of a lens The	311	100	compilation	5	316	
Furniture for a photogrammetric			Section organization of	1316	10	
office	142	22	Personnel	1316B	10	
Cabinets	1425	25	Supervisor	1316A	10	
Drafting lights	1422	24	determinations photogrammetric			
Drawing boards	1421	23	horizontal angles			
Photograph rails	1423	24	Horizontal photographs	3712	226	
Radial plot table	1424	24	vertical angles and <i>illus</i>			
			<i>tration</i>	fig 3 58	227	
			Oblique photographs	3732	240	
			Vertical photographs	3251	126	
			vertical angles			
			Horizontal photographs	3713	228	
			elevation difference			
			<i>illustration</i>	fig 3 59	228	
			Oblique photographs	3733	243	
			index	153	35	
			Horizontal control	1537	41	
			Photograph	1536	39	
			size of templet for			
			numerical			
			example	1536	39	
			formula for	equation 3242I	123	
			Project	1539	42	
			<i>illustration</i>	fig 1 18	40	
			Vertical control	1538	41	
			Intersection	3253	129	
			<i>illustration</i>	fig 3 9	129	
			Resection	3252	127	
			<i>illustration</i>	fig 3 8	128	
			Grass in water			
			delineation of	5423B	343	
			<i>symbol</i>	fig 5 36	429	
			Grassland not mapped	5433	363	
			Gravel			
			delineation of	5423D	343	
			Sand and	5433B	365	
			and boulder areas			
			delineation of contours			
			about	5432Dg	361	
			<i>symbol</i>	fig 5 23	416	
			Grids map	413	266	
			base	4134	269	
			types to be used	4132	268	
			checking of			
			detail of	full size <i>illustra</i>		
			tion	fig 4 4b	272	
			inking	4135	270	
			intervals and numbers	4136	270	
			Lambert	413	267	
			numbering and intervals	4136	270	
			photogrammetric manuscripts types			
			of	used on	4135	270
			projections on a map manuscript			
			and <i>illustration</i>	fig 4 4a	271	
			record of	on Form T 1	5811	407
			review of	5811-1	407	
			State coordinates	413	266	
			Transverse Mercator	413	267	

G

248-249



	Reference No	Page		Reference No	Page
Ideal condition for viewing stereoscopic photographs <i>illustration</i> <i>fig 3 15</i>	3 15	144	Instructions (see Project instructions)		
Identification cards			aerial photography (see also General)	24	88
control horizontal station	4114	258	altitude and scale	2412	88
<i>illustration</i> <i>fig 4 2</i>	4 2	259	altitude of the sun	2432	91
Washington Office File	8225	499	camera maintenance	244	93
control radial plotting	4251	290	coverage photograph	242	89
Photo (topo) points and photo hydro points on photo graphs of	461	308	crab	2423	90
Photo hydro points	4612	310	end lap	2421	90
Photo points	4611	309	film shipment	245	94
Image definition			flight lines placement	2411	88
optical	319	106	flying for photography	241	88
photography in	3242	125	maintenance of cameras	244	93
rectification in	361	201	Nine lens camera care and operation	2441	93
displacement			Overlap		
combined effect	3224	113	end	2421	90
due to			side	2422	90
relief <i>example 1</i>	3232	117	placement of flight lines	2411	88
scale <i>example</i>	3224	113	quality of photography	2431	90
tilt <i>examples 1 2 3 and 4</i>	3432	166	Reports	246	94
<i>formula</i> <i>equation 3 4 3 2 A</i>	3 4 3 2 A	164	Scale and altitude	2412	88
pattern due to			shipment of film	2412	88
relief			side lap	2422	90
scale			solar altitude diagram	2432	91
tilt			special photographs	247	94
radial plotting effect of in	4212	282	test exposures	2433	92
relief	323	114	tilt	2413	88
scale	3224	113	turns	2414	89
tilt	343	164	Building delineation (General)	5446 A	373
amount	3432	164	Compilation	1517	84
direction	3431	164	constructing a perspective grid	375	250
distance computation <i>example</i>	315	104	Contouring	1516	84
formation with a simple lens	315	102	Field edit	1518	34
<i>illustration</i> <i>fig 3 2</i>	3 2	102	Field inspection	1513	33
movement			general	1511	32
during exposure, <i>example 4</i>	3242	125	project	1511	32
<i>formula</i> <i>equation 3 2 4 2 L</i>	3 2 4 2 L	125	Horizontal control	1512	32
photography in aerial	3242	125	Hydrographic data	1514	33
scale	3441	170	Orienting photographs for stereoscopic viewing and for stereoscopic training	334	151
tilt and relief <i>illustration</i> <i>fig 3 3 4</i>	3 3 4	170	Photogrammetric Office review	5811	406
size on retina <i>formula</i>	331	141	radial plotting mailing control points	415	276
Inclination			Reports and records	1519	35
any line on a tilted photograph of			stereoscopic viewing	334	151
<i>example 1</i>	3424	163	supplementary	151	32
approximate solution <i>example 3</i>	3424	163	vertical control	1515	33
<i>illustration</i> <i>fig 3 3 0</i>	3 3 0	162	Instruments	141	13
Index			aerial photographic	233	81
contours			Air thermometer	2333	84
definition and delineation of	5432 A a	357	Altimeter	2332	82
delineation of	357	357	Automatic pilot	2335	85
graphic project	1536	40	Bombsight	2336	85
<i>illustration</i> <i>fig 1 1 8</i>	1 1 8	40	Compass		
of refraction	314	101	flux gate astro	2331	81
Indexes			Drift sight	2334	84
card photography	1541	43	Druit sight	2338	87
graphic (see also Project Layouts and )	153	35	Intervalometer	2338	87
Horizontal control	1537	41	Miscellaneous	2339	87
Photographs aerial	1536	39	Solar navigator	2337	86
Project	1539	42	Solar pilot director	2337	86
Vertical control	1538	41	Thermometer air	2333	84
Indexing			airplane photographic	23	77
aerial photographs	262	98	beam compasses	1418	21
checking photographs and	4111	254	Dividers	1414	18
photographs			Drafting (see also Equipment) and lettering pens	141	13
<i>formulas</i> for <i>equations 3 2 4 2 A to H</i>	122	122	description of	141	13
radial plotting for	4111	254	<i>illustration</i> <i>fig 1 2</i>	1 2	15
Infrared photography	2264	77	Pens	1411	15
Int (s)			Lettering sets	1413	18
delineating on map manuscript for	512	318	Miscellaneous items	1419	22
outlining on photographs for	5412	331	office equipment	141	13
plastic corrosive action	141	16	Protractors	1417	21
thinner plastic	512	318	Scales	1415	19
use of for Reading plotters	6244 (f)	460	stereoscopic plotting	6	442
use on photographs	5412 (f)	331	Straightedges	1416	20
Inting			Intermediate contours		
on photographs	5412	331	definition and delineation of	5432 A b	357
Photographic Information on temp lets	4244	289	merged into curving contour of levees etc		
Inner cone of catographic camera	2222	65	Intermittent		
<i>illustration</i> <i>fig 2 4</i>	2 4	65	dianige symbol	5 25	418
Inspecting aerial photographs	262	98	lake or pond delineation of	5431 B b	355
Inspection			symbol	5 26	419
aerial negatives of	8231	500	stream		
indexing and	262	98	delineation of	5431 A b	355
map manuscript after review of	8472	511	symbol	5 25	418
			Interocular distance stereoscopy	3331	145
			Interphone system airplane	2339	87



	Reference No	Page
Interpretation photographic	52	320
Alongshore areas	5231D	323
Bluffs	5231D	323
Cultural features	5232	325
Drainage	5231B	323
Field inspection	521	321
High water line	5231D	324
Physical features	5231	322
Relief	5231 A	322
Rocks	5231C	324
Rural areas	5232 A	325
Shoreline	5231C	324
Stereoscopic	522	322
Vegetation	5231C	323
Intersection		
graphic	3253	129
<i>illustration</i>	<i>fig 3 9</i>	129
in space	3534 A B	198
radial plotting	463	314
Interval (s)		
exposure — between photographs	3242	124
<i>formula</i> — <i>equation</i>	<i>3 2 3 K</i>	124
seconds <i>example 3</i>	3242	125
projection or grid	4136	270
<i>illustration</i> — <i>table 1 2</i>	4136	270
Intervalometer	2338	87
Inverse position computation and		
form number	4143	275
iris of the eye	3131	140
Islands elevations on topographic maps	5424B	346
Isocenter		
definition	341	158
Angles at	3423	161
Distance to	3422	159
Line	3421	159
<i>formula</i> — <i>equation</i>	<i>3 4 2 2 B</i>	160
location <i>examples 1 and 2</i>	3422	160
radial plotting — in	4112	254
tilt angle — line bisects the	3441	159
<b>J</b>		
Jetty (ies)		
delineation of	5425 A	348
<i>symbol</i>	<i>fig 5 28</i>	421
Junctions map manuscripts	541	330
compilation report	7261	493
delineation along	5414	333
review of	5811-34	410
<b>K</b>		
K-17 camera	2221	62
with 12 inch lens <i>illustration</i>	<i>fig 2 2</i>	63
K-20 camera	2224	67
<i>illustration</i>	<i>fig 2 2</i>	66
Kelp		
delineation of	5423B	343
<i>symbol</i>	<i>fig 5 2 3</i>	416
Key to		
data stamped on single lens aerial photographs	156	46
<i>illustration</i>	<i>fig 1 1 9</i>	46
photograph numbers	156	46
KFK plotter	61	443
Kelsh plotter	61	442
<b>L</b>		
Laboratory	26	97
aerial photographic		
Indexing	262	98
Inspecting	262	98
Printing equipment	264	99
Processing	261	97
Types of photographs	263	98
Processing	261	97
and records	26	97
Lakes and ponds		
delineation of	5431P	355
Intermittent	5431Lb	355
Natural and artificial	5431Ba	355
<i>symbol</i>	<i>fig 5 2 6</i>	419
Lambert Grid	413	267
Land grant(s)		
Claims reservations public land surveys	5453Cf	386
public land surveys		

	Reference No	Page
Land grant(s)—Continued		
<i>symbol</i>	<i>fig 5 4 4</i>	437
Land lines public land surveys	5453Cf	386
report	714	476
Landmark(s)		
buildings		
definition	5446	372
names	5416G	335
delineation		335
compilation report	7261	493
control point <i>symbol</i>	<i>fig 4 1</i>	434
definition	4611B	309
delineation of	5463B	394
elevations and heights	5425P	353
on form 567		353
to be shown	425P	353
field inspection report	724	489
plane of reference for elevations	5424A	345
preparation and transmittal of records	713	474
review of — on map manuscript	5811-17	408
Lateral shift of the eyes stereoscopy	3333	147
Latitude and longitude scale	1415	20
<i>illustration</i>	<i>fig 1 5</i>	402
use of	4152	278
Layouts and indexes (see also in indexes graphic)	153	37
planimetric	1532	35
<i>illustration</i>	<i>fig 1 7</i>	37
project (see also Project layouts)	153	35
shoreline	1531	37
topographic	1533	37
Leading line (range) <i>symbol</i>	<i>fig 5 3 0</i>	423
Ledge(s)		
definition of		345
delineation of	5424A	345
<i>symbol</i>	<i>fig 5 2 3</i>	416
Ledger record of published maps	871	516
Legend to photograph numbers	156	46
Legibility		
drafting of map manuscript	51	316
map manuscript review of	5811-35	410
Lens		
aberration	221	62
aerial camera	318	105
Distortion		106
Field of view	319	107
Image definition		106
Speed		106
eye — of the human	331	140
<i>f</i> /number <i>example</i>	319	106
focal length of a		
computation <i>example 9</i>	315	104
of a rectifier	<i>fig 3 4 4</i>	203
function of a	311	100
law formula	315	102
pinhole analogy	313	101
position		
computation for sharp focus <i>example 1</i>	315	104
in terms of magnification and focal length <i>example (1)</i>	317	105
requirements aerial photography	221	61
sample — the	315	102
<i>formula</i> — <i>equation</i>	<i>3 1 1 C</i>	103
speed	319	106
stereoscopes	1444	27
<i>illustration</i>	<i>fig 1 1 2</i>	27
wide angle	319	107
Lettering	513	319
for map manuscripts sample	<i>fig 5 4 7</i>	440
filehand for use on map manuscript	513	319
sample	<i>fig 5 1</i>	319
guide	<i>fig 5 4 8</i>	441
instructions for — on map manuscript	513	319
orientation of	5417	336
<i>illustration</i>	<i>fig 5 4</i>	336
placement of — on manuscript	5417	336
<i>illustration</i>	<i>fig 5 5</i>	337
sets	1413	18
Levees		
delineation of	5425J	351
contour(s)		360
spoil banks	5432Dd	360
Dikes		351
Spoil banks	5425J	351
<i>symbol</i>	<i>fig 5 4 0</i>	433



	Reference No	Page		Reference No	Page
Map(s)—Continued					
Revision(s)—Continued					
new manuscripts of less than					
standard accuracy _____ of	885	518	Metal templates ( <i>see also</i> Spider temp	441	299
procedures for map _____	881	517	lets) _____	1415	19
purpose of _____	881	517	Meter Bar drafting scale _____		
scale of a _____	3221	110	Method by Professor Maiston Morse	3535	199
for formula _____ equation	3221	110	tilt determination _____	1415	19
Relative map scales _____	121	3	<i>illustration</i> _____ <i>fig</i>	1 3	19
tabulation _____ table	1 1	3	Metric scales _____	221E	61
shoreline _____ definition _____	1a	31	_____	222	62
source material _____	1544	44	_____	2221	62
symbol ( <i>see also</i> Symbols) _____ <i>figs</i>	5 21 to 5 48	414-441	_____	2222	64
topographic _____, definition _____	15	31	MHW definition _____	5424A	345
weather _____	2121	60	Midpoint radial plotting _____	4112	254
<i>illustration</i> _____ <i>fig</i>	2 1	60	graph for determining _____	4212	283
Mapping			<i>illustration</i> _____ <i>fig</i>	4 7	283
coastal _____ photographs for _____	2111	57	_____	413	266
Delineation			Military Grid(s) _____	4134	269
land lines _____	5453Dd	389	Mine <i>symbol</i> _____ <i>fig</i>	5 35	428
section and township corners _____	5453De	388	Mirror(s)		
Field surveys _____	54a3Db	388	mine lens camera _____	2232	70
land lines _____	5453Dd	389	stereoscope _____	1442	28
Public land survey data _____	5423D	387	<i>illustration</i> _____ <i>fig</i>	1 13	28
corners _____	388		Miscellaneous		
definitions _____	5453Da	388	chapter _____	9	519
Marine			Coordination of surveys _____	91	519
railways			Equipment, aerial photography _____	2339	87
delineation of _____	5425G	851	Features		
symbol _____ <i>fig</i>	5 27	420	names _____	5416K	335
vegetation delineation of _____	5423B	342	physical delineation of _____	5431H	356
Marking			Reference books _____	94	585
control			Schneider Stereoscope _____	93	534
instructions _____	415	276	Tmetricon mapping _____	92	528
methods of _____	4114	260	Mixed woods <i>symbol</i> _____ <i>fig</i>	5 37	430
points _____	415	276	MLLV, definition _____	5424A	345
radial plotting _____	4114	258	MLV definition _____	332	142
detail points on photographs _____	462	311	Model stereoscopic definition _____		
on photographs _____	5412	331	Monthly report		
Marks			journal _____ and _____	717	478
fiducial _____	341	157	preliminary _____	716	477
floating _____	335	155	Monument(s)		
Marsh(es)			boundary _____ <i>symbol</i> _____ <i>fig</i>	5 44	437
and swamps delineation of _____	5431D	355	field inspection report on _____	724	489
definition _____	5431D	355	Monumented bench mark _____	5466	395
delineation of _____	5431D	355	definition of _____	5466	395
grass delineation of _____	5423C	343	delineation of _____	5 14	395
Mangrove and other swamp areas			<i>symbol</i> _____ <i>fig</i>	5 14	395
delineation _____	5423C	343	vertical angles _____	5466	395
Planimetric and topographic			definition _____	5466	395
manuscripts _____	5423Ca	343	delineation _____	5 15	395
Shoreline manuscripts _____	5423Cb	343	<i>symbol</i> _____ <i>fig</i>	5 15	395
shoreline interpretation _____	5231D	325	Moraine glacial, <i>symbol</i> _____ <i>fig</i>	5 26	419
<i>symbol</i> _____ <i>fig</i>	5 36	429	Mosaic(s)		
Marston Morse tilt solution _____	355	199	effect of tilt on _____	913	520
Mask lines mine lens photograph _____	622	449	project planning and surveys _____	345	174
Master template _____	622	449	for _____	913	520
camera O _____	431	297	shingle _____	8231	500
<i>illustration</i> _____ <i>fig</i>	4 76a	297	Mountain top elevations for a given		
Ratio prints only _____	431	297	overlap <i>example</i> 5 _____	3242	126
<i>illustration</i> _____ <i>fig</i>	4 76b	297	Movement of image during exposure	3242	125
Material for drafting sheeting _____	4131	267	formula _____	3242L	125
Mean			Mud		
high water line			delineation of _____	5423D	343
definition _____	5424A	345	interpretation of _____	5231D	325
interpretation _____	5231D	324	<i>symbol</i> _____ <i>fig</i>	5 22	415
symbols _____ <i>fig</i>	5 22	415	Muddy water shoreline interpretation	5231D	325
low water			Multiplex		
definition _____	5424A	345	apparatus _____	631	462
lower _____ definition _____	5424A	345	<i>illustration</i> _____ <i>fig</i>	6 7	462
sea level plane of reference _____	5424A	345	bridging with cross flights _____	1593	55
Meander			<i>illustration</i> _____ <i>fig</i>	1 2°	55
corner			contour interval formula _____	632	465
definition _____	5423De	389	control requirements		
delineation _____	5423De	389	horizontal _____	1593	54
lines public land surveys _____	5453Ce	386	vertical _____	1595	56
Mechanical			Manuscript preparation _____	632	465
orientation and adjustment radial			1 10 000 scale _____	6322	466
plotting _____	532	323	1 20 000 scale _____	6321	466
templates _____	44	298	model scale formula _____	632	465
Mechanism			projection		
parallax generator _____ Reading			description of _____	63	461
plotter _____	6241	454	manuscript preparation of _____	632	465
<i>illustration</i> _____ <i>fig</i>	6 4	454			
stereoscope pantograph _____ Reading					
plotter _____	6241	454			
<i>illustration</i> _____ <i>fig</i>	6 5	454			
Mercator Grid _____	413	267			
transverse _____	267	267			
Metal mounted photographs _____	6244	458			
use of _____	6244(b)	458			

N

Nadir point		
definition _____	341	158
distance to _____	3422	160
formula for _____	3422A	160
location <i>examples</i> 1 and 2 _____	3422	160
nomogram for determining the		
position of the _____ after		
rectification _____ <i>fig</i>	3 55	223





	Reference No	Page		Reference No	Page
Pen(s)			Plot report radial plotting	725	490
contour	} 141	17	review of	5811-10	408
drafting		15	point(s)		
map manuscript delineation			definition footnote	461	308
for	5111	317	Pending plots for	6244e	459
drop bow spring	141	17	station classified as control		
lettering	} 1412	17	and	159	51
Payzant		18	Records Washington Office	fig 5 4 I	484
points steel		17	Accuracy tests of	823	500
map manuscript delineation			Aerial (photographic) negatives	8236	502
for	5112	317	compilation distribution filing	8231	500
tabulation of different types			of	823	500
ruling	table 1 2	17	disposal of old	821	498
speedball	1411	15	Field edit records	8235	502
Penholders	1412	18	Field inspection photographs	8233	502
Perennial Streams delineation of	5431Aa	354	Field survey records	8232	501
symbol	fig 5 2 5	418	filing of	823	500
Periods, not used in symbols illustration	fig 5 2 1	414	Map manuscripts descriptive ie		
Perpendicular photograph	341	157	points	8234	502
Persistence of vision stereoscopy	331	141	Project completion	8238	503
Personnel			Registration of archives	8237	503
aerial photography	2312	79	routing and disposal of	821	498
graphic compilation section	1316B	10	review of contours on map manu		
radial plotting section	1314B	8	script	5811-23	409
review section	1317B	11	surveys	913	520
stereoscopic mapping section	1315B	9	advantages and limitations of		
Perspective			for coastal mapping	912	519
center of a photograph	341	157	alongshore features location of	9151	520
Grid numerical example	375	252	offshore features location	9152	524
construction illustration	fig 3 6 5	250	Theory chapter on	3	100
theory of illustration	fig 3 6 6	252	Horizontal and oblique photo		
projection	321	107	graphs	37	224
relation of the various forms of a photograph, illustration	fig 3 3	109	Near vertical photographs	34	157
Photo			Optical principles	31	100
elevation control classification	159	51	Rectification	36	199
symbol	fig 5 4 2	435	Stereoscopy	33	139
hydro point			Tilt determination	35	188
definition and identification of			Vertical aerial photographs	32	107
in radial plotting	4612	310	Photogrammetry		
preparation of photographs con			blunders and errors	912	520
sideration of in	4116	262	coastal surveys application of		
symbol	fig 5 4 2	435	to	911	519
-hydro station			history brief of	11	1
definition	159	51	reference books	942	536
delineation of	914	522	Photograph(s) aerial		
limitations	5464	394	adjustment of during map		
precautions	914	522	delineation	531	328
procedures for location of	914	522	Airport plans for	2113	58
review of on map manu			Card indexes	1541	43
script	5811-7	407	chart field for operations		
selected and located sometimes			planning	1571	48
without field inspection	914	522	Coastal mapping for	2111	57
interpretation (see also Interpretation)	52	320	comparison with a map geometri		
topo points and stations			cally	321	108
definitions	159	50	completion (see Delineation)		
Delineation of	461	208	Coverage	242	89
Azimuth marks	5463C	394	Crab	2423	90
Fixed aids to navigation	5463A	394	End lap	2421	90
Landmarks	5463B	394	inadequacy of	158	50
radial plotting	4611	309	instructions relative to	242	88
Aids to navigation	4611A	309	lens comparison to single		
Azimuth marks	4611C	310	lens (table 2 2)	2331	67
Landmarks	4611B	309	Side lap	2422	90
	3713	229	data stamp	1572	49
Photoalhade, Wilson	921	528	delineation	53	326
	fig 3 5 6	225	disposal of field inspection	8233	502
Photo transit (see Photoalhade)			field definition of	1572	48
Photogrammetric			inspection (field) data manu		
contours on map manuscript re			scripts and field edit		
view of	5811-23	409	data to accompany	715	476
elevation point symbol	fig 5 4 2	435	Charts	1571	47
office			Preparation	1572	48
organization	131	5	review of field inspection photo		
Administrative assistant and			graphs	5811-38	410
clerical force	1313	7	use of for field work	157	47
chart illustration	fig 1 1	6	Files Washington Office	8222	498
Graphic compilation section	1316	10	indexes	8227	500
Radial plot section	1314	7	card	1541	43
Review section	1317	11	graphic	1536	39
Stereoscopic mapping section	1315	8	Indexing	262	98
Supervision by officer in charge	1311	6	Inspecting	262	98
Supervisor in charge	1312	7	appraisal of negatives and	8231	500
quarters	132	12	Interpretation	52	320
review of the map manuscript	7262	496	Characteristics of photographic		
Associated data and its	58	405	detail	523	322
form T-2, illustration	fig 5 2 0	406	Field inspection for of		
			photographs	521	321
			perspective center viewing of		
			photographs from	52	321
			shadows orientation of photo	52	321
			graphs with respect to	fig 5 2	321

	Reference No	Page		Reference No	Page
Photograph(s) aerial—Cont d			Physical features—Continued		
Interpretation—Continued			review of — on map manuscript,		
Stereoscopic observation of aerial			instructions for	5811	409
photographs	522	322	Other alongshore physical fea-		
tural photographs	{341	159	tures	5811-18	408
lower and upper sides defined	{fig 3 28	158	Other physical features	5811-26	409
Nautical chart revision, — for	2112	58	Piers and wharves		
nine lens			definitions and delineation of —	5425M	352
coverage	2231	67	symbols	{fig 5 27	420
illustration	{fig 4 1	255	Piling and submerged piling		
transformer errors radial plot-			delineation of —	5425F	350
ting	4213	283	symbol	{fig 5 27	420
numbering key	156	46	Pilot automatic aerial photograph	2335	85
ordering prints	156	46	Pinhole lens analogy	313	101
orientation of — for map deline-			Pipe lines submerged delineation of	5425L	351
ation	531	328	Placement		
preliminary radial plot for deter-			Flight lines — of in aerial pho-		
mining a erage scale of	412	264	tography instructions	2411	88
perpendicular definition	341	157	Lettering on map manuscript	{5417	386
preparation			{fig 5 5	387	
delineation of map manuscript,			{5424A	345	
for	5412	331	{fig 5 7	346	
field work — for	1572	48	Planes of reference		
radial plotting — for	411	254	Planetable		
marking detail points	462	311	point and station, classified as con-		
slotted templates — with	4421	305	trol	159	51
spider templates — with	4411	299	review of contours on map manu-		
Printing	264	99	script	5811-22	409
Processing	261	97	vertical control for — mapping	1594	55
Rack	{1423	24	Planimetric		
{fig 1 9	24	24	drafting smooth of — maps	853	513
Reconnaissance — for	2114	58	flight planning for — mapping	3241	119
records of	712	473	layouts of — maps	{1532	32
required for various work phases	712	473	{fig 1 17	37	
sale to the public	21	57	map manuscripts delineation of		
scale			alongshore physical features	{5423	342
average for a strip formula, ex-			marsh	{fig 5 6b	341
ample	412	264	physical features	5423	343
factor example	4114	260	woodland	5433Ab	364
focal length and flying height			maps	15	31
— in terms of	3222	113	shoreline manuscripts — and		
formula — equation	3272C	111	delineation of hachures		
ground distance — in terms of			on	5432Fa	363
a example 1	3222	112	Topographic manuscripts — and		
map distance — in terms of a			delineation of marsh on	5423Ca	343
example 2	3222	113	Planimetry instructions for (see also		
separation effect of in stereoscopy	3334	147	Project instructions)	151	32
spacing in aerial photography	2338	87	Planning		
Related topics — and	3242	121	control for photogrammetric map		
transferring — detail to a map	53	326	ping	159	50
types of	263	98	flights for aerial photography (see	{25	95
uses of	211	57	also Flight planning)	{324	117
vertical	32	107	project	13	30
Photographer, aerial photographic	2312	79	Plastic		
Photographic aerial			inl	512	318
inplan	23	77	sheeting		
film characteristics of	225	73	base grids — for	4131	267
laboratory (see also Laboratory)	26	97	cellulose acetate characteristics		
Quality instructions concerning	2431	90	and care of	4131	267
weather	2121	59	drafting on	511	317
Photography aerial (see also Aerial)	{243	57	preparation for	512	317
Adequacy	158	50	map manuscripts — for	4131	267
report on	725	491	overlays discrepancy for	57	404
Alaska — in	2122	59	vinylite characteristics and care of	4131	267
cost of	21	57	of	{6244	460
index of	3227	500	Plot radial (see also Radial plotting)	4	254
card	1541	43	Plot report photogrammetric	725	490
graphic	1536	39	review of	5811-10	408
instructions			Plotter		
quality of photographs	2431	90	Reading — description of models		
special	247	91	A and B	624	452
operations	232	79	illustrations		
Quality of	2431	90	model A	{fig 6 3	452
Solar altitude diagram	2432	91	model B	{fig 6 6	456
season	212	58	rectoblique — description of	{923	533
Test exposures	2433	92	{fig 9 7	533	
Theory of flight planning	324	117	Plotting		
use of	211	57	Control stations on map manu-		
weather	2121	59	scripts	415	276
Physical features			Azimuth of angle and distance		
delineation of	543	353	— by	4154	279
alongshore	5423	342	Base grids and base projections		
Miscellaneous	5431H	356	on	416	280
planimetric or topographic manu-	5423	343	Coordinates — by	4153	279
script — on a	{fig 5 6b	341	Dms and Dps — by	4151	277
shoreline manuscript, — on a	{5423	343	Latitude and longitude scales	4152	278
{fig 5 6a	343	340	Three point fix positions	552	401
interpretation of	5231	322	Transfer — by	4155	280
Alongshore areas	5231D	323	Instruments stereoscopic	6	442
Drainage	5231B	323	Radial (see also Radial —)	4	254
Relief	5231A	322	table radial	{1424	24
Vegetation	5231C	323	{fig 1 10	25	
			templet radial	{4242	287
				{fig 4 13	288

	Reference	Page		Reference	Page
Plotting—Continued	No		Principle of—Continued	No	
Three point fix positions	552	401	stereoscope mirror	{1442	28
Plumb			stereoscopic photographs	{fig 1 14	28
line photogrammetric theory	341	158		{332	142
point of nadir point	341	158		{fig 3 14	143
Plywood drawing board	{1421	23	Printing		
	{fig 1 7	22	aerial photographs	264	99
Point control	159	50	Equipment	264	99
Poivilliers stereotopograph	61	442-444	procedures for	802	512
Polaroid stereoscopy	332	142	Prior maps and surveys use in com-		
Political division boundaries delineation of — on map manu-	script {5451	379	pilation	1544	44
	{fig 5 44	437	Prism stereoscopy	{1443	28
Polyconic projection	413	266		{fig 1 10	29
Tables	412	264	Probable diamage unsurveyed sym-		
Pond natural artificial			bol	fig 5 25	418
delineation of	5431Ba	355	Procedures		
intermittent, delineation of	5431Bb	305	coastal mapping — for	913	520
symbol	fig 5 26	419	Map manuscript completion — of	591	412
Porro principle	61	443	Collection of descriptive report		
Positive identification of control	4251	291	and accompanying data	5913	413
Post office names on map manuscripts	5416D	304	Field edit	5911	412
Power line(s)			Map manuscript correction	5912	413
clearings delineation of	5433	363	Verification of field edit correc-		
interpretation	5232A	326	tions	5914	413
symbol	fig 5 30	423	radial plotting (see also Radial		
Telephone lines and telegraph			plot)	4	254
lines delineation of	5444	371	scheduling a mapping project		
Practical and theoretical rectification	fig 3 46	506	in	913	520
Precision aerial camera	2232	64	Processing aerial photographs	261	97
Preface of a descriptive report	7232	486	Progress		
Preliminary			reports	716	477
monthly report	716	477	sketch	716	477
Office procedures	1	1	descriptive report, — in	7231	486
Equipment and instruments	14	13	Project		
General statement	11	1	code number	15	80
Outline of operations	13	5	Completion	{8238	503
Project planning	10	30		{86	515
Requirements for map accuracy	12	2	File Washington Office	8226	499
Radial plot assembly	4252	291	index (see also Project layouts)	153	35
determining average scale of	412	262	graphic	{1536	39
photographs	{fig 4 3	263		{fig 1 18	40
Reading plotters — for	6244b	460	Instructions for		
Review (see also Office inspection)	83	504	Compilation	1517	34
Preparation			Contouring	1516	34
Discrepancy overlav — of	571	404	Field edit	1518	34
map manuscript — of			Field inspection	1513	33
Drafting for smooth	844	509	Horizontal control	1512	32
Filing — for	548	400	Hydrographic data	1514	33
Photographs office for radial plotting			Reports and records	1519	35
Azimuth lines	411	254	Topography and planimetry	151	32
Horizontal points	4113	256	Vertical control	1515	33
Indexing and checking photo	4114	258	Layouts and graphic indexes	153	35
graphs	4111	254	Horizontal control — of	1537	41
Pass points	4115	261	Names of topographic maps	1535	39
Photo points and photo hydro			Photographs — of	1536	39
points	4116	262	Planimetric map	1532	37
Radial centers	4112	254	Project	1539	42
Slotted templet method	4421	305	Registry numbers — of	1534	39
Spider templet method	4411	299	Shotline surveys	1531	37
Templet plotting from a calibra-			Topographic map	1533	37
tion photograph	4242	287	Vertical control — of	1538	41
Transfer of points to adjoining			number code	15	30
photographs	4117	262	Planning	15	30
Templet plotting from a calibra-			Adequacy of photography	108	50
tion photograph	4242	287	Classified data	155	45
Reproduction copy — of	852	512	Control	109	50
Pressure altitude table aerial pho-			Coordination of parties	152	35
tography	2332	83	Instructions	151	32
Primary axis, gimbal mechanism	366	210	Layouts and indexes	153	35
Principal			Ordering photographs	156	46
distance of a photograph	341	157	Photographs for field work	157	47
line of a tilted photograph	341	158	Source material	154	42
plane of a tilted photograph	341	158	report	{718	478
point of a photograph				{86	515
assumption in radial plotting	3251	127	Source material	154	42
definition	341	157	Control records	1542	43
Roads and principal city arterial			Maps and prior surveys	1544	44
streets names on map			Map records	1543	44
manuscript	5416J	335	Photograph card indexes	1541	43
Principle of			Projection(s)		
Azimuth line in radial plotting	3254	130	angle onto an inclined plane		
floating mark, stereoscopy—	{335	155	of an example 2	3424	163
intersection graphic in radial	3253	129	map — and grids	{413	266
plotting	{fig 3 9	129		{4136	270
parallax absolute stereoscopic	3261	131	checking — on map manu-		
resection graphic in radial plot-	3252	127	scripts	4132	268
ting	{fig 3 8	128	Construction	413	266
sl etchmaster	{922	529	Base grids	4134	269
	{fig 9 4	530	Hand construction projections		
			and grids	4133	263
			Map manuscripts — on	{4136	270
				{fig 4 4a	271
				{fig 4 4b	272



Projection(s)—Continued	Reference No	Page
map—Continued		
Construction—Continued		
Map projections	4135	270
Ruling machine — with	4132	268
Sheetings for	4131	267
grid constructed on a projection	4135	270
inking — on map manuscripts	4136	270
intervals and numbers ( <i>table</i> 4 2)	4136	270
kinds used for photogrammetric	413	266
maps	4136	270
numbering of intervals	4136	270
polyconic projection tables for		
construction	413	266
record of — on Form T-1	5811	407
review of — on map manuscript	5811-1	407
Ruling machine for constructing	4132	268
Sheetings for constructing	4131	267
slewed — limitations	4132	268
types used	413	266
orthogonal — of a map compared to the photograph perspective	4136	270
perspective — of a photograph compared to orthogonal map idea	321	108
Projector		
map — ratio reflecting	143	26
use of —	fig 1 11	26
multiplex	532	328
multiple	631	462
Proof		
copy of map examination of	727	496
edit		
drafting — of smooth	857	514
map manuscript preparation by		
reviewer for	844	509
purpose and instructions	857	514
property line definition	545	379
tractors	1417	21
Provisional map	885	518
Public		
building(s)		
definition of a —	5446	372
delineation of —	5446D	375
names of — on map manuscript	5416F	385
land		
lines ( <i>see also</i> Public land surveys)		
classified as reliable or unreliable	5453Dd	389
review of — on map manuscript		
script	5811-32	409
symbols	fig 5 44	437
surveys	5453	381
claims grants and reservations	5453Cf	386
data to be mapped	5453D	387
delineation of land corners	5453De	389
description of system of	5453C	382
field data submitted for compilation	5453Db	388
field inspection of —	5453Db	388
Grants claims and reservations	5453Cf	386
History brief of —	5453I	382
Information general, about	5453A	381
land lines classed as reliable or unreliable	5453Ca	382
Mapping of — data	5453Dd	389
Meander lines	5453D	387
reservations grants and claims	5453Ce	386
Sections	5453Cf	386
System of —	5453Cd	385
Townships	5453C	382
Townships subdivided into sections	5453Cc	384
24 mile tracts	5453Cd	385
types of — corners	5453Cb	384
	5453Da	388
Publication of maps	85	512
Pupil of the eye	851	512
Purpose of coastal mapping	321	140
	15	30
	81	497

Q

Quality of aerial photography	2431	90
Quality symbol	fig 5 35	428
Quarters selection of for photogrammetric office	132	12

R	Reference No	Page
Use of		
de meation	5448B	378
	fig 5 35	428
Rad for photographs	1423	24
	fig 1 9	24
Radial		
Assumption radial plotting	3251	126
center radial plotting	4112	254
midpoint a practical compromise	3434	168
	4212	282
	fig 4 7	283
symbol	fig 5 42	435
transfer of — to map manuscript		
script	4254	293
distance of an image on a photograph		
graph	3241	119
plot(s) and plotting	4	254
aids to navigation treatment of	4611A	309
	42	281
	424	287
	425	289
	43	296
	44	298
Displacements and distortions		
affecting the —	421	281
Nine lens photographs with hand templates	424	287
	425	289
Assumption radial	fig 4 14	294
azimuth	3251	126
Lines on nine lens photographs	423	286
	fig 4 10	286
mail's treatment of	fig 4 11	286
Completion of	4611C	310
Photo points and photo locations	46	307
points identification and location of	461	308
Reading plotters locating control for	464	315
control	415	276
	416	280
data for plotting	414	273
hand templet plots — for	1591	52
identification card	4114	258
mailing — on photographs	4114	258
mechanical templet plots — for	1592	54
detail points definition selection	462	311
Direct —	463	314
Displacements and distortions affecting the assembly of	45	306
Extension the — and its	421	281
Hand templates for — using	3255	130
nine lens photographs	424	287
identification card control	fig 4 14	294
isocenter	4114	258
isocenter	4112	254
Landmark's special treatment in locating	4611B	309
Locating points on map manuscript	463	314
mailing		
control on photographs	4114	258
detail points	462	311
mechanical templates	44	298
	442	305
Slotted templet method	fig 4 20	304
	fig 4 21	306
	441	299
Spider templet method	fig 4 17	300
	fig 4 18	301
	fig 4 19	302
midpoint for use as radial center	4112	254
	3434	168
nine lens photographs — with Assembling with hand templates	42	281
Azimuth lines on —	425	289
control identification	423	286
Displacements and distortions	4251	290
paper distortion	421	281
Pass points on —	4213	283
Preliminary assembly of —	425	290
tilt corrections	4252	291
transformer errors	4211	281
	4213	283
pass points distribution of	4115	261
	422	284
single flight strip	4221	285
two nine lens photographs	fig 4 8	285
	4222	285
	fig 4 9	285



Relief—Continued	Reference	Page	Review—Continued	Reference	Page
displacement <i>example 1</i> —Con	No		Instructions—Continued	No	
computer graph	{337	217	Bridges	5811-15	408
delineation — in formula	{fig 3 50	217	Buildings	5811-28	409
detail points — effect of num	462	313	Contours		
ber of	462	311	in general	5811-24	409
direction of	3231	114	photogrammetric	5811-23	409
elevations, — and, <i>example 2</i>	{3232	117	planetable	5811-22	409
formulas 3232A and 3232B	{462	313	Control stations	5811	407
parallax — and	3232	115	Cultural features	5811	409
difference	3264	135	alongshore	5811-19	409
photograph — on a tilted	{3264	135	other	5811-30	409
features symbols	{fig 3 12	136	Descriptive report	5911-37	410
interpretation	3433	167	Detail points	5811-11	408
tilt — and	{figs 5 38-5 40	431	Discrepancy overlay	5811-36	410
displacements	5231A	322	Field inspection photographs	5811-38	410
combined <i>example</i>	4212	282	General	5811	410
radial lines, — effect on	{3434	168	Geographic names	5811-33	410
radial plotting — combination	351	190	Grids	5811-1	407
tolerated in ( <i>table 4 3</i> )	{fig 3 30	169	Horizontal control	581-5	407
additional	{fig 3 40	190	Junctions map manuscript	5811-34	410
Remarks, review of map manuscripts	3434	167	Landmarks	5811-17	408
additional	{fig 3 32	168	Legibility	5811-35	410
Reports (and records) ( <i>see also Rec</i>	4211	282	Low water line	5811-13	408
oids and reports)	5811-41	410	Map manuscript		
aerial photography	5811-43	410	number	5811-3	408
compilation	{71	470	size	5811-4	407
notes	{table 7 1	472	Miscellaneous	5811	410
cost	246	94	Natural ground cover	5811-21	409
annual	726	491	Nautical chart data	5811	408
monthly	5418	338	Office forms	5811-39	410
Descriptive	717	478	Photo hydro stations	5811-7	407
Field edit	72	479	Physical features	5811	409
Field inspection	727	496	alongshore	5811-18	408
Field lines	724	486	other	5811-26	409
land lines — on	714	476	Projection	5811-1	407
Photogrammetric plot	725	490	Public land lines	5811-32	409
photography — instructions	246	94	Radial plot report	5811-10	408
preliminary monthly	716	477	Railroads	5811-29	409
preparation and routing of	71	472	Remarks	5811-41	410
required	1519	85	additional	5811-43	410
tabulation of	71	473	Roads	5811-27	409
review of	583	411	Rocks	5811-14	408
Representative fraction	3221	108	Sextant fixes	5811-9	408
Reprinting maps	872	516	Shoreline	5811-12	12
Reproduction			Signatures	5811-40	410
copy preparation of	852	512	Spot elevations	5811-25	409
procedure	852	512	Title	5811-2	407
Requirements			Topographic stations	5811-6	407
lenses for mapping — of	221	61	Water features	5811-20	409
Map Accuracy	12	2	Map manuscript	58	405
Coast and Geodetic Survey	122	4	Overlay discrepancy	582	410
National Standards	121	2	photogrammetric office — form	5811	406
radial plotting — of control for	1591	52	T-2	{fig 5 20	406
vertical control — of			(S)	84	500
multiplex — for	1595	56	Report (s)	{8417	510
planetable — for	1594	55	map manuscript inspection of		
Reading plotter — for	1596	56	after review	8472	511
Resection			records — and	583	411
graphic	{3252	127	registration, — and	{847	510
space — in	{fig 0 8	128	Washington Office instructions	{8473	511
Reservation (s)	3534	197	for	8471	510
Boundaries	5452	381	section		
delineation of	5452	381	organization of	1317	11
symbol	{fig 5 44	437	personnel of	1317A	11
public land surveys	5453Cf	386	Supervisor of	1317B	11
Resolving power lens	221	61	Washington Office	84	506
Responsibility (ies)			comparison of map manuscript		
descriptive report — shown in			with		
sections — of	131	5	hydrographic surveys	8433	507
Restricted classified data	155	45	maps of other agencies	8432	506
Resume of current (stereoscopic) in			nautical charts	8434	508
struments	61	442	other maps	843	506
Retina			prior Bureau surveys	8431	506
eye — of the	331	140	completion	8	497
size of image on — formula	331	141	project	83	515
Revetment symbol	{fig 5 28	421	geographic names	845	509
Review			hydrography on topographic		
Discrepancy overlay	582	410	manuscripts application of	846	510
inspection of map manuscripts			inspection after review	8472	511
after	8472	511	map manuscripts		
Instructions	5811	406	corrections made in red	8234	502
Additions and corrections	5811-42	410	inspection in Washington Office	83	504
Aids to navigation	5811-16	408	study and report	842	506
Alongshore areas	5811	408	procedures	841	505
Bench marks	5811-8	408	projects assignment by	841	505
Boundary (ies)	5811	409	purpose	841	505
lines	5811-31	409	registration	{847	510
			related to nautical charts	81	497
			review report	{847	510
				{8471	510

	Reference No	Page
Revision(s)		
map	88	517
extensive	883	517
extent limited	882	517
sheet	884	518
definition of	884	518
distribution and filing of	884	518
Riprap <i>symbol</i>	<i>fig 5 28</i>	421
Rivers		
delineation of	5431A	354
Streams — and delineation of	5431A	354
Braided	5431Ad	355
Disappearing	5431Ac	355
Intermittent	5431Ab	355
Perennial	5431Aa	354
RK rock, <i>symbol</i>	5424C	347
	<i>fig 5 24</i>	417
Road(s)		
classification	5441	366
map symbols	<i>fig 5 31</i>	424
	<i>fig 5 32</i>	425
delineation on shoreline manu-		
scripts	5441A	369
interpretation	5232A	325
map manuscripts		
names on	5416J	335
review of — on	5811-27	409
objectives		
<i>symbol</i>	<i>fig 5 32</i>	425
topographic maps specifications		
for	5441	366
route numbers and names	5441	366
Trails — and		
delineation of	5441	366
shoreline manuscripts	5441A	369
under construction delineation	5441	366
urban areas — in	5441	366
widths, maximum	5441	366
Rock(s)		
alongshore	9152	524
awash definition of	5424A	345
bare definition of	5424A	345
delineation of	5424A	345
elevations of	5424B	346
topographic maps — on	5424B	346
when shown	5424B	346
height determinations recording		
time of	5471	397
hydrographic surveys comparison	8433	507
identification		
errors in	9154	525
field	5424B	347
ledge		
identification	5231D	325
<i>symbol</i>	<i>fig 5 22</i>	415
lettering elevations	54	329
map manuscripts — on photo	5424C	347
grammatic	9152	524
review of	5811-14	408
nautical charts comparison with	9154	525
offshore	9152	524
photograph	<i>fig 1 9</i>	24
planes of reference for —	5424A	345
	<i>fig 5 7</i>	346
elevations	5424A	345
plotting positions determined by		
field party by sextant		
angles	551	400
Reefs and ledges	5424	345
definitions	5424A	345
Field inspection notes	5424B	346
Rules of application for delinea-		
tion	5424C	347
submerged shoreline interpretation	5231D	324
sunken definition of	5424A	345
symbolization	5424C	347
<i>symbols</i>	<i>fig 5 24</i>	417
tide corrections to elevations	547	397
	5471	397
Rocky		
bluff <i>symbol</i>	<i>fig 5 40</i>	433
coasts interpretation	5231D	324
Rods, of the eye	331	140
Rotation and translation <i>formulas</i>	5462G and 3462H	179
Poundhouse <i>symbol</i>	<i>fig 5 33</i>	426
Routing and disposal of photogram	82	498
metric records	821	498
division files	822	498
Photogrammetric records	823	500

	Reference No	Page
Runed piers, <i>symbol</i>	<i>fig 5 27</i>	420
Runs		
delineation of	5446E	375
historical names on map manu-		
scripts	5416I	335
Rules of application to c/s reefs,		
ledges	5424C	347
Ruling machine projections and grids	4132	263
Partial areas, interpretation	5232A	325

S

Saddles, topographic, contour delinea-		
tion	5432Dh	360
Sale of photographs	21	57
Salt evaporators		
delineation of	5431C	355
<i>symbol</i>	<i>fig 5 36</i>	429
Sand		
delineation of	5423D	343
	5433B	365
topographic map manuscripts		
on	5433Bd	365
dune(s)		
delineation of	5433B	365
contours	5433Dh	361
<i>symbol</i>	<i>fig 5 40</i>	433
symbolization when not con-		
toured	5433BA	365
types	5433B	365
Gravel, sand and gravel boulders		
and sand dunes delinea-		
tion of	5433B	365
Gravel, sand and gravel mud and		
boulders interpretation of	5423D	325
Sand dunes — and delineation		
of contours about	5423Dh	361
shoreline interpretation	5241D	325
<i>symbols</i>	<i>fig 5 22</i>	415
Santoni stereocartograph	61	442
Scale(s)		
Altitude — and		
aerial photography	2412	88
photography instructions	2412	88
data from two photographs	3531	196
single photograph adaptation to		
a	3531B	197
unknown ground distance	3531A	197
determination photographs radial		
plot	412	262
displacement of images <i>example</i>	3224	114
drafting	1415	19
foot	1415	20
latitude and longitude	1415	20
meter bar	1415	19
quarter meter	1415	19
topographic	1415	20
error correction <i>formulas</i>	562	404
factor(s) ( <i>table 4 1</i> )	412	265
<i>formula</i>	4114	260
map manuscripts — for scaling		
distances from	562	404
photograph — of a <i>example</i>	4114	260
Focal length and flying height	322	108
foot	1415	19
	<i>fig 1 4</i>	19
fraction representative	3221	109
image	3441	170
	<i>fig 3 34</i>	170
displacement due to	3224	113
latitude and longitude	1415	20
	<i>fig 1 5</i>	20
map — <i>example</i>	3221	110
<i>formula</i>	3221A	110
metric	1415	19
	<i>fig 1 3</i>	19
multiplex model — of <i>formula</i>	632	465
photograph(s) — of	3222	110
average <i>example</i>	412	264
equation for — factor	412	264
factor	412	265
focal length and flying height	3222	113
<i>formula</i> general	3222C	111
ground distance — in terms of		
<i>example 1</i>	3222	112
map and photograph distance,		
— in terms of	3222	113
nomograph	3222	112
	<i>fig 3 5</i>	112
scale relations of $\alpha$ —	3222	110

	Reference No	Page		Reference No	Page
Scale(s)—Continued			Sharp focus—Continued		
plot			image distance computation <i>ex</i>	315	104
preliminary for determining average age of photographs	{412 fig 4 3	262	ample 1	4131	267
radial plotting and	412	262	Sheeting for map manuscripts		
plotting	561	402	Shipment of film photography instructions	245	94
point	3442	172	Shoal(s)		
construction of	{3442 fig 3 35	172	Channels and Brealers	5423E	344
definition of	3442	172	definition	5123E	344
example	3442	172	delineation	5423E	344
method tilt determination	352	192	lines delineation of	5423E	344
Relative map (table 1 I)	121	3	shoreline interpretation of	5231	325
representative fraction	3221	109	symbol	fig 5 22	415
Sylai Lockebie	{561 fig 5 19	402	Shoreline		
tilt		403	accuracy of (see map accuracy)		
change due to example 1	3441	171	apparent	5421	339
effect of	344	169	definition of	{5421 5231D	338
Scaling positions on map manuscript	56	402	delineation of	5421	338
correction for scale of map projection	562	403	within control symbols	5426	353
Scarps delineation	5423A	342	depression (dip) angle (table 3 4)	3715	237
Scheduling mapping project	913	620	details compilation report	7261	493
Scheimpflug condition, rectification	{361 fig 3 4	201	features symbols	figs 5 22-2 24	415
Schneider stereoscope	{93 fig 9 8	534	field inspection report of	724	488
Schools			interpretation of	5231D	324
Churches and delineation of	5446D	375	marsh and swamp areas	5231D	325
interpretation	5232L	326	photographs on	5231D	324
names delineation	5416B	334	tidal data for	5473	399
symbols	fig 5 0 4	427	line weights	5421	339
Scotch Edge	548	400	located when not identifiable	542L	339
Scrub woodland symbol	fig 5 37	430	map manuscript(s)		
Sea level plane of reference	5424A	345	alongshore physical features on	5423	342
Sea Walls			a	fig 5 6a	340
Bulkheads and interpretation	5425N	352	boundary lines generally omitted		
symbol	fig 5 28	421	on a	545	379
delineation of	5424N	352	delineation of		
Season(s)			marsh	5423Cb	343
photographic	212	58	physical features	543b	353
Report	718	478	roads	5441A	369
Weather and			woodland	5433Ac	365
photography	212	58	topographic manuscripts made		
Alaska in	2122	59	concurrently with	541	330
weather	2121	59	review of	5811-12	408
Seaweed shoreline interpretation	5231	325	maps (see also Shoreline surveys)	15	31
Secondary axis symbol	366	213-214	Mean high water line delineation	5421	338
Secret classification date	155	45	photographs field how is in		
Section			dictated on	5421	339
corner			stage of tides must be known for	547	397
accepted	{5453Dc fig 5 12	389	accurate identification	5472	398
original	{5453Dc fig 5 11	388	survey(s)	15	31
symbols	fig 5 44	437	definition of	5421	338
line			drafting		
definition	545	379	shoreline manuscripts (see Drafting)		
symbol	fig 5 44	437	smooth	854	514
public land	5453Cd	385	Tides and delineation of	5472	398
Selection			Side lap	{2422 3242	90
camera of aerial	251	95	minimum aerial photography	3242	121
criteria photographic film	2204	74	formulas for	3242M & N	126
detail points of	{462 fig 4 22	311	photography instructions	2422	90
Sending manuscripts and records	715	476	Signatures		
Sensation of relief	332	142	Responsibility and description	7211	481
Sensitivity of the eye acuity factor	331	141	review of map manuscripts	5811-40	410
Separation of the photographs stereoscopic	3334	147	Simple lens		
Sequence of contents descriptive report	721	481	image formation with a	{315 fig 3 2	102
Assembly of report	7214	482	law	315	102
Copies required	7212	482	Simplification of formulas rectification	365	210
Page numbering	7213	482	tion	3532	197
Signatures and responsibility	7211	481	Single lens cameras	222	62
Sextant fix(es)	55	400	Panchild Cartographic Camera	2222	64
General information	561	400	E-51 Camera	2223	66
map manuscripts on review			K-17 Camera	2221	62
of	5811-9	408	Oblique photography camera	2224	66
Plotting	552	401	Size of		
symbol	fig 5 42	435	circles on map manuscripts control		
Shading diagram photographic laboratory	622	449	points	6244g	460
Shadow(s)			image on retina formula	331	141
effect of orientation in viewing an aerial photograph	{52 fig 5 2	320	map manuscript review of	5811-4	407
aerial photograph	fig 5 35	321	templet for photo indexing example	1536	39
Shaft opening mine symbol	fig 5 35	428	Sketch showing typical displacement pattern due to tilt scale	{351 fig 3 40	189
Sharp focus			and moderate relief	922	529
condition rectification	{361 fig 3 43	201	Sketchmaster	{9222 fig 9 6	532
		202	oblique	922	529
			principle of a	fig 9 4	530

	Reference No	Page		Reference No	Page
Sketchmaster—Continued			Special		
universal —————	9222	532	case if distance is unknown tilt		
vertical —————	9221	530	determination —————	3531A	197
	<i>fig 9 5</i>	531	Contours — treatment of delineation		
Slip			ation —————	5432D	359
patent — delineation of ———	5425G	351	Alignment of contours ———	5432Da	357
symbol —————	<i>fig 5 27</i>	420	Bridges —————	5432Df	361
	442	305	Cuts and fills —————	5432De	361
Slotted templet —————	4421	305	Depressions —————	5432Dc	360
	<i>fig 4 20</i>	304	Gravel sand and gravel and		
assembling radial plots with —	4423	306	boulder areas —————	5432Dg	361
construction of —————	4422	305	Levees and spoil banks ———	5432Dd	360
Method —————	442	305	Tops and saddles —————	5432Db	360
preparation of oblique photographs	4421	305	Sand and sand dunes —————	5432Dh	361
Sloughs			photographs instructions ———	247	94
delineation of —————	5423F	344	Reprints —————	714	475
symbol —————	<i>fig 5 25</i>	418	Geographic names —————	714	476
Sluice gate symbol —————	<i>fig 5 29</i>	422	Boundary —————	714	476
Smooth			land lines — on —————	714	476
Compilation drafting map manu			Specifications Map accuracy (see		
script —————	854	514	also Accuracy) —————	12	2
Drafting and publication ( <i>see also</i>			Spectral distribution of daylight —	2261	75
Drafting for reproduction			<i>fig 2 9</i>	<i>fig 2 9</i>	75
and publication) —————	85	512	Speed		
General statement —————	851	512	film aerial —————	22a2	73
Planimetric maps —————	853	513	lens — formula example ———	319	106
Proof edit —————	857	514	Spider templet(s) method ———	441	299
Reproduction copy preparation			construction of —————	4412	302
of —————	852	512	photograph preparation ———	4411	299
Shoreline surveys —————	854	514	radial plot assembly of with —	4413	302
Topographic maps —————	855	514	<i>fig 4 19</i>	<i>fig 4 19</i>	302
Verification of drafting ———	856	514	parts and tools for their assembly	441	299
Snags			<i>fig 4 17</i>	<i>fig 4 17</i>	300
delineation of —————	5435F	350	Spot elevations		
symbol —————	<i>fig 5 28</i>	421	definition —————	5432E	361
Snell's law of refraction ———	314	101	classification — and ———	5467	396
Snow fields			delineation of —————	5467	396
delineation of —————	5431F	356	5432E	361	
symbol —————	<i>fig 5 26</i>	419	checked definition of ———	5467	396
Solar			photogrammetric —————	5467	396
altitude diagram time and dura			uncheeked definition of ———	5467	396
tion aerial photography ———	2432	91	lettering elevations of ———	54	329
instructions —————	<i>fig 2 11</i>	91	point classification ———	159	51
navigator —————	2337	86	review of — on map manuscripts	5811-25	409
pilot director —————	2337	86	selections of — map manuscripts	5432E	361
Solid analytic geometry of the aerial			symbol —————	<i>fig 5 42</i>	435
photograph —————	347	183	where shown —————	5432E	361
	<i>fig 3 39</i>	184	Spings		
angle between two directed lines,			delineation of —————	5431E	356
<i>example 4</i>	347	186	symbol —————	<i>fig 5 26</i>	419
coordinate transformation in three			Stadium(s)		
dimensions <i>example 7</i> ———	347	188	delineation of —————	5448B	378
coordinate translation in three di			symbol —————	<i>fig 5 5</i>	428
mensions <i>example 1</i> ———	347	183	Stales fish delineation of ———	5425I	351
direction cosines of a line <i>ex</i>			Stamp		
<i>ample 3</i>	347	186	field date —————	1572	49
distance from perspective center to			<i>fig 1 21</i>	<i>fig 1 21</i>	49
an image <i>example 2</i> ———	347	185	156	46	
equations of a line in space, <i>ex</i>			photograph data —————	<i>fig 1 19</i>	46
<i>ample 5</i>	347	186	Standard(s)		
relation of tilt and swing to the			map —————	872	516
transformation matrix <i>ex</i>			accuracy — (see also Accu		
<i>ample 6</i>	347	187	lacy) —————	122	4
Some factors affecting the selection			purpose and instructions for —	872	516
of flying height —————	3241	117	Parallel definition of ———	5453Cb	384
geometric principles —————	342	159	revisions — for —————	872	516
Distances to the nadir point and			Stite		
isocenter —————	3422	159	boundary symbol —————	<i>fig 5 44</i>	437
Horizontal angles exist at the			coordinate system —————	413	266
isocenter —————	3423	161	Grids —————	413	266
Inclination of any line the —	3424	161	highway numbers —————	<i>fig 5 32</i>	425
Isocenter line bisects the tilt			Station		
angle the —————	3421	159	control —————	159	50
Soundings planes of reference for	5424A	345	identification cards filing —	8225	499
Source material map manuscript —	154	42	names (special cases) symbols —	<i>fig 5 43</i>	436
Control records —————	1542	43	railroad — name delineation —	5416E	335
Maps and surveys —————	1544	44	symbols on map manuscript —	<i>fig 5 43</i>	436
Records —————	1543	44	Statistical and cost data ———	717	478
Photograph card indexes ———	1541	43	Steel pen points ( <i>table 1 2</i> ) —	1412	17
Space			use of —————	5112	317
Intersection general case ———	3534A	198	Stereocartograph Santoni ———	61	442
Elevations known —————	3534B	198	Stereocompariagraph, plotter —	61	443
Orientation —————	3534	197	Stereogram —————	334	155
Resection —————	3534	197	<i>fig 3 24</i>	<i>fig 3 24</i>	153
Spacing			aerial photographs — made from	334	151
between symbols —————	<i>fig 5 21</i>	414	a pair of —————	<i>fig 3 25</i>	154
flight strips to assure minimum			floating marls — showing —	335	155
side lap for given eleva			<i>fig 3 27</i>	<i>fig 3 27</i>	156
tions — of —————	3242	126	Stereographometer Nistru ———	61	443
formula —————	3242M	126			
flights over rough terrain — of,					
<i>example 6</i>	3242	126			
photographs — of formula for —	252	97			

	Reference No	Page		Reference No	Page
Stereopantometer	61	443	Streams—Continued		
Stereoplantograph	64	466	shoreline interpretation	5321D	325
Stereoscope(s)	144	27	<i>symbols</i>	<i>fig 5 25</i>	418
F-71 Fairchild	1444	29	Stumps		
interpretation — and	<i>fig 1 16</i>	30	delineation of	5425F	350
Lens	522	322	<i>symbol</i>	<i>fig 5 28</i>	421
<i>fig 1 12</i>	1441	27	Subdivision		
Mirror	1442	28	county — boundary, <i>symbol</i>	<i>fig 5 44</i>	437
principle of —	1442	28	township — of a	<i>fig 5 10a</i>	383
<i>fig 1 14</i>	6241	453	24 mile tracts into townships	5453Cb	384
pantograph mechanism	6241	453	of	<i>fig 5 10</i>	383
Prism	1443	28	Submerged		
Schneider	93	534	cables delineation of	5425L	351
Stereoscopic	93	534	piling delineation of	5425F	350
acuity	331	141	pipe lines delineation of	5425L	351
multiplex	631	461	rocks shoreline interpretation	5231D	325
aerial photographs, — observa			Subsection corner		
tion of	522	322	definition of	5453Dc	389
contours on map manuscripts re			delineation of	5453Dc	389
view of	5811-23	409	Substitute		
mapping section			center radial plot	4112	254
organization of	1315	9	point <i>symbol</i>	<i>fig 5 41</i>	434
Personnel	1315B	9	delineation of	5465	395
Supervision of	1315A	9	identification card	4114	258
model	333	144	<i>fig 4 2</i>		
definition	332	142	plotting a —	4143	275
deformation caused by			point classification	159	50
eye base not parallel to azi	3335	148	radial plotting use of —	4114	258
muth line	<i>fig 3 20</i>	149	Summary of the effects of tilt	345	173
equally tilted photographs	3336	149	Sun en rocks definition	5424A	345
equal tilt or unequal flying	3336	149	Supervision by Officer in Charge	1311	6
height	<i>fig 3 22</i>	149	Supervisor		
increase in viewing distance	3332	145	duties of —	131	6
lateral movement of the eyes	3333	147	in Charge duties of	1312	7
separation of photographs	3334	147	Graphic Compilation Section,		
shortened eye base	3331	145	of	1316B	10
unequal tilt	<i>fig 3 16</i>	145	Padal Plot Section — of	1314B	8
Parallax	3262	133	Review Section — of	1317B	11
<i>fig 3 10</i>	3261	131	Stereoscopic Mapping Section		
formulas	3261B C and 3262A B	131	of	1315B	9
photographs			Supplemental		
examination of — importance	522	322	contours definition and delineation		
in compilation	<i>fig 3 15</i>	144	of	5432Ac	358
plotting instruments	6	442	data compilation report	7261	493
multiplex	63	461	Supplementary contours, where used	5432Ac	358
apparatus	631	461	Surf		
radial plotting for —	<i>fig 6 7</i>	462	delineation of	5423E	344
<i>fig 6 7</i>	6244C	458	shoreline interpretation	5231D	325
Reading plotter			Survey		
Model A	6241	453	contemporary —	5414	333
Model B	6242	457	material for — prior source	8433	507
Resume of —	<i>fig 6 6</i>	456	records field routing and disposal	8471	511
Stereoplantograph	61	442	reference books	1544	44
principle	332	142	system public land surveys	8232	501
<i>fig 3 14</i>	33	139	<i>fig 5 13</i>	941	535
Stereoscopy	33	139	5453C	382	
Deformations of model	333	144	Swamp		
Floating mark	335	155	aies	5423C	343
Human eye the	331	139	definition	5431D	355
Instructions for viewing photo-			delineation	5431D	355
graphs	334	151	woodland cover in swamp — of	5431D	355
Sensation of relief	332	142	shoreline interpretation	5231D	324
<i>fig 3 14</i>	61	442-444	<i>symbol</i>	<i>fig 5 36</i>	429
Stereotopograph Poirvillers	61	442-444	Swing		
Stone Walls Stone Fences, Fences,			definition of — distinction	3462	177
Hedges and Crop Lines			Relation of tilt — and nadir		
delineation of —	5445	371	point	3463	179
<i>symbols</i>	<i>fig 5 30</i>	423	Sylar Lockerbie scale	561	402
Storm water line definition and in			<i>fig 5 19</i>	403	
terpretation	5231D	324	Symbols		
Straightedges	1416	20	Abbreviations — and	514	320
Streams			map —	<i>figs 5 21-5 48</i>	414-441
delineation of	5431A	354	Abbreviations	<i>fig 5 45</i>	438
Braided	5431Ad	355	accepted section corner	<i>fig 5 44</i>	437
Disappearing	5431Ac	355	aid to navigation	<i>fig 5 43</i>	436
Intermittent	5431Ab	355	airport limits	<i>fig 5 43</i>	436
Perennial	5431Aa	354	airport	<i>fig 5 35</i>	423
			amusement parl	<i>fig 5 35</i>	423
			apparent shoreline	<i>fig 5 22</i>	415
			approximate low water line	<i>fig 5 22</i>	415
			approximate mean high water		
			<i>fig 5 22</i>	415	
			<i>fig 5 41</i>	434	
			<i>fig 5 35</i>	428	
			<i>fig 5 42</i>	435	
			<i>fig 5 28</i>	421	
			<i>fig 5 40</i>	433	
			<i>fig 5 36</i>	429	
			<i>fig 5 35</i>	423	
			<i>fig 5 23</i>	416	
			<i>fig 5 44</i>	437	

Symbols—Continued	Reference No	Page
map—Continued		
boundary limit lines -----	fig 5 43	436
braided stream -----	fig 5 25	418
breakers -----	fig 5 23	416
breakwater -----	fig 5 23	421
bridges -----	fig 5 29	422
buildings -----	fig 5 34	427
bulkhead -----	fig 5 28	421
cable crossing -----	fig 5 30	423
canal -----	fig 5 25	418
canal navigable -----	fig 5 22	415
carline (interurban railway) -----	fig 5 33	426
cemetery limits -----	fig 5 43	436
channel line -----	fig 5 22	415
church -----	fig 5 34	427
clearing line -----	fig 5 30	423
cloverleaf -----	fig 5 32	425
contours -----	fig 5 38	431
Control points -----	figs 5 41	434
coral -----	fig 5 23	416
corporate limits -----	fig 5 44	437
county boundary -----	fig 5 44	437
cranberry bog -----	fig 5 36	429
Cultural features -----	figs 5 27	420
cut -----	fig 5 39	432
cypress -----	fig 5 37	430
cypress swamp -----	fig 5 36	429
dams -----	fig 5 29	422
dead end street -----	fig 5 32	425
deciduous trees -----	fig 5 37	430
deletions -----	fig 5 21	414
depression contours -----	fig 5 38	431
detail point -----	fig 5 42	435
ditch -----	fig 5 25	418
dock -----	fig 5 27	420
dolphin -----	fig 5 27	420
dry dock -----	fig 5 27	420
duck blind -----	fig 5 28	421
dune -----	fig 5 40	433
Drainage features -----	figs 5 25	418
evaporator salt -----	fig 5 36	429
evergreen trees -----	fig 5 37	430
excavations -----	fig 5 35	428
fairgrounds -----	fig 5 35	428
federal highway numbers -----	fig 5 32	425
ferries -----	fig 5 29	422
fill -----	fig 5 39	432
firebreak -----	fig 5 30	423
fish trap stakes -----	fig 5 28	421
fixed aid to navigation -----	fig 5 43	436
floating dock -----	fig 5 27	420
ford -----	fig 5 29	422
form line -----	fig 5 38	431
foul areas -----	fig 5 23	416
gas well -----	fig 5 34	427
glacial moraine -----	fig 5 26	419
glacier -----	fig 5 26	419
glade land -----	fig 5 36	429
golf course -----	fig 5 35	428
grade crossing -----	fig 5 32	425
grass in water -----	fig 5 36	429
gravel -----	fig 5 23	416
grom -----	fig 5 28	421
guide lines for lettering -----	fig 5 48	441
high water line -----	fig 5 22	415
highway numbers federal		
state -----	fig 5 32	425
Highway -----	figs 5 31	424
and -----	5 32	
horizontal (control) point -----	fig 5 41	434
ice field -----	fig 5 26	419
intermittent drainage -----	fig 5 25	418
intermittent lake or pond -----	fig 5 26	419
intermittent stream -----	fig 5 25	418
jetty -----	fig 5 28	421
help -----	fig 5 23	416
lake -----	fig 5 26	419
land grant line -----	fig 5 44	437
landmark control point -----	fig 5 44	437
leading line (range) -----	fig 5 30	423
ledge -----	fig 5 23	416
levee -----	fig 5 40	433
limit lines -----	fig 5 43	436
locks -----	fig 5 29	422
low area -----	fig 5 36	429
low water line -----	fig 5 22	415
mangrove -----	fig 5 37	430
marine railway -----	fig 5 27	420
marsh -----	fig 5 36	429
mean high water line -----	fig 5 22	415
mine -----	fig 5 35	428
mixed woods -----	fig 5 37	430
monument, boundary -----	fig 5 44	437

Symbols—Continued	Reference No	Page
map—Continued		
moraine glacial -----	fig 5 26	419
mud -----	fig 5 22	415
names of special control		
stations -----	fig 5 43	436
national boundary -----	fig 5 44	437
navigable canal -----	fig 5 22	415
navigational aid -----	fig 5 43	436
nursely -----	fig 5 37	430
objectives road -----	fig 5 32	425
obstruction -----	fig 5 23	416
oil well -----	fig 5 34	427
orchard -----	fig 5 37	430
overpass -----	fig 5 32	425
palmetto -----	fig 5 37	430
palm tree -----	fig 5 37	430
parish boundary -----	fig 5 44	437
park limits -----	fig 5 43	436
pass point -----	fig 5 42	435
patent slip -----	fig 5 27	420
periods not used in symbols -----	fig 5 21	414
piers -----	fig 5 27	420
piling -----	fig 5 27	420
photo (grammetric) eleva-		
tion point -----	fig 5 42	435
photogrammetric point -----	fig 5 41	434
photo hydro point -----	fig 5 42	435
pond -----	fig 5 26	419
Pdu -----	fig 5 25	418
perennial stream -----	fig 5 25	418
political divisions boundary -----	fig 5 44	437
power transmission line -----	fig 5 30	423
probable drainage unsur-		
veyed -----	fig 5 25	418
public land lines -----	fig 5 44	437
quarry -----	fig 5 35	428
race track -----	fig 5 35	428
radial center -----	fig 5 42	435
railroads -----	fig 5 33	426
ramp -----	fig 5 28	421
rapids -----	fig 5 26	419
reef -----	fig 5 22	415
relief features -----	figs 5 38-5 40	431
reservation boundary -----	fig 5 44	437
revestment -----	fig 5 28	421
riprap -----	fig 5 28	421
road classification map		
symbols -----	fig 5 32	425
road objectives -----	fig 5 32	425
rock ledge -----	fig 5 22	415
rocks -----	fig 5 24	417
rocky bluff -----	fig 5 40	433
roundhouse -----	fig 5 33	426
runed piers -----	fig 5 27	420
salt evaporator -----	fig 5 36	429
sand -----	fig 5 22	415
sand dunes -----	fig 5 40	433
school -----	fig 5 34	427
scrub woodland -----	fig 5 37	430
seawall -----	fig 5 28	421
section corner -----	fig 5 44	437
section line -----	fig 5 44	437
sextant fix -----	fig 5 42	435
shaft opening mine -----	fig 5 35	428
shoal -----	fig 5 22	415
Shoreline features -----	fig 5 22	415
slip -----	fig 5 27	420
slough -----	fig 5 25	418
sluice gate -----	fig 5 29	422
snag -----	fig 5 28	421
snow field -----	fig 5 26	419
spacing between symbols -----	fig 5 21	414
spot elevation -----	fig 5 42	435
spring -----	fig 5 26	419
stadium -----	fig 5 35	428
state boundary -----	fig 5 44	437
station names		
(special cases) -----	fig 5 43	436
station symbols on		
manuscript -----	fig 5 43	436
stone wall or fence -----	fig 5 30	423
streams -----	fig 5 25	418
stump -----	fig 5 28	421
subdivision county boundary -----	fig 5 44	437
substitute point -----	fig 5 41	434
swamp -----	fig 5 36	429
tanks circular horizontal -----	fig 5 34	427
telegraph line -----	fig 5 30	423
telephone line -----	fig 5 30	423
theoretical section corner -----	fig 5 44	437
tidal bench mark -----	fig 5 42	435
title block lettering sample -----	fig 5 46	439
topographic point -----	fig 5 41	434



Symbols—Continued	Reference	Page
map—Continued	No	
township line	fig 5 44	437
traffic circle	fig 5 32	425
transmission line	fig 5 30	423
tunnel opening mine	fig 5 37	428
tunnel	fig 5 32	425
turntable railroad	fig 5 33	426
underpass	fig 5 32	425
vegetation and swamp limits	fig 5 36	429
vertical (control) point	fig 5 42	435
viaduct	fig 5 32	425
vineyard	fig 5 37	430
wash damage	fig 5 25	418
water line symbols	fig 5 22	415
well gas oil well	fig 5 34	427
woodland cover	fig 5 37	430
wharf	fig 5 37	430
wheels	fig 5 23	416
zoo	fig 5 35	428
map manuscript — on	514	320
Reading plotters, — for	6244(I)	461

T

Table(s)		
depression of the shoreline at different distances from the horizon	table 3 4	237
dip of the apparent horizon	table 3 3	236
drawing —	{1421	23
	{fig 1 8	23
elevation correction for curvature and refraction in feet distances in		
feet	table 3 1	235
meters	table 3 2	235
pressure altitude	2332	83
radial plotting —	{1424	24
	{fig 1 10	25
Taking		
aerial photographs	232	79
ideal condition in — photo	{333	144
graphs for viewing	{fig 3 15	144
Tanks	5446G	377
circular		
delineation of	5446Ga	377
symbol	fig 5 34	427
horizontal		
delineation of	5446Gb	377
symbol	fig 5 34	427
Telegraph line symbol	fig 5 30	423
Telephone lines		
delineation of	5444	371
interpretation	5232A	326
symbol	fig 5 30	423
Templet(s)		
assembly of radial —		
final	4253	292
primarily	4252	291
radial plotting	4	254
Nine lens hand	42	281
Single lens hand	43	296
Single lens mechanical	44	298
calibration —	{4242	287
	{fig 4 12	287
hand mine lens	424	287
assembly of	425	289
collection of	4243	288
making information on	4244	289
preparation of	4242	287
master		
Cameras 'D', 'O'	{431	297
	{fig 4 16a	297
ratio prints only	{431	298
	{fig 4 16b	297
Mechanical		
Cardboard	442	305
Metal	441	299
Paper	442	305
Slotted	442	305
Spider	441	299
plotting radial with —	{4242	287
	{fig 4 13	288
radial plotting —	4	254
control for —		
hand templets	1591	52
mechanical templets	1592	54
hand templets single-lens photo		
graphs	43	296
size photo indexing — for examples	{1536	39
	{3242	124
formula	equation 3242I	123

Templet(s)—Continued	Reference	Page
slotted —	{4422	305
radial plot assembly with	{fig 4 20	304
spider	4423	306
assembly	{4412	302
	{fig 4 18	301
parts and tools for assembly	4441	302
	{fig 4 17	300
radial plot assembly with	{4413	302
	{fig 4 19	302
transparent —	4241	287
Temporary control defined	159	52
Theodolite station point classification		
tion	159	51
Test exposures photography instructions	2433	92
Theoretical		
corner		
definition of —	5453Da	388
delineation of —	5453Dc	389
section — symbol	fig 5 44	437
rectification, — and practical	{364	206
	{fig 3 46	206
Theory		
flight planning — of	324	117
Photograph spacing and related topics	3242	121
Some factors affecting the selection of flying height	3241	117
perspective grid, — of	{375	249
	{fig 3 66	252
photogrammetry — of	3	100
Horizontal and oblique photographs		
Near vertical photograph	37	224
Optical principles	34	157
Rectification	31	10
Stereoscopy	36	199
Tilt determination	33	139
Vertical aerial photograph	35	188
radial plotting — of (see also Radial plotting theory)	32	107
Graphic intersection	325	126
Graphic resection	3253	129
Principle of the azimuth line	3252	127
Radial assumption	3254	130
Thermometer aerial photography	3251	126
Thin lens formula C	2333	84
Thinner for ink	315	103
Three point problem	512	318
graphic solution	3252	127
radial plotting	425	290
Sextant fixes	55	400
Plotting —	552	401
Tidal		
bench mark definition and delineation of	{5466	395
	{fig 5 17	396
	{fig 5 42	435
Drainage delineation of	5423F	344
Tide(s)		
Computations	5471	397
form M-2617-12 for —	fig 5 18	398
Corrections	547	397
Bridge clearances — applied to — and	5473	399
Shoreline — and	5472	398
Tilt of an aerial photograph		
aerial photographic instructions relative to —	2413	88
analytic geometry of —	{3461	174
	{fig 3 36	175
data		
oblique photograph — of	3731	237
Vertical photograph from elevations alone — of a new	3533	197
determination methods	35	188
Anderson (see also Scale point)	352	192
Displacement	{351	189
	{fig 3 40	190
fundamental relation example formula	3432	164
Elevations alone — by	353	197
Maarten Moise	3535	199
Scale point	{3531	197
	{fig 3 41	193
fundamental relation example formula	3441	170
Displacement	{343	164
	{fig 3 31	165
Amount of — examples for formula	3432	164

	Reference	Page		Reference	Page
Tilt of an aerial photograph—					
Continued					
Displacement—Continued	No		Trails—Continued	No	
Duction of —————	3431	164	interpretation of —————	5232A	325
Tilt and relief combined	3434	167	Unsteering radial plotting		
Tilted photograph — on a	3433	167	detail from photograph to map		
ffects summary of —————	345	173	manuscript —————	53	326
scale — on —————	344	169	Pass points and radial centers	4254	293
formulas			Points to adjoining photographs	4117	262
displacement ————— equation	3432B	166	radial center —————	4113	256
scale change ————— equation	3441C	171	radial plot points to map manu		
nadir point relations — and	{3463	179	script —————	4254	293
problems analytic geometry	{fig 3 33	180	Transforming printer nine lens	{2332	70
Plane —————	346	174	errors corrections for use in radial	622	446
Solid —————	347	183	plotting —————	{fig 6 1	447
radial plotting			layout dimensions, constants	365	210
affect of tilt and relief	{3434	167	Transformation coordinates of im-	{fig 3 47	212
amount of tilt and relief to be	4211	282	ages		
tolerated —————	4211	281	rectification —————	36	199
correction for tilt —————	{3434	168	three dimensions orthogonal ex	ample 7	347
Relief displacements combined with	fig 3 33	169	two dimensions formulas example	3462	179
— example —————	fig 3 40	190	Translation of coordinates of images		
scale change example —————	3441	171	in three dimensions ex		
swing and nadir point relations	3463	179	ample 1 —————	347	183
analytical transformation mat			Transmission line		
rix example 6 —————	347	187	interpretation —————	5232A	326
Tilted photographs (see also Near			symbol —————	fig 5 30	423
Vertical) —————	34	157	Transparent sheets for templates		
geometry of —————	{3421	139	radial plotting —————	4241	287
nomenclature —————	{fig 3 29	139	Transverse Mercator grid	413	267
	341	157	universal —————	4134	269
	{fig 3 28	158	Trap fish delineation of	5425I	351
Title			Traverse stations		
block lettering of sample	fig 5 46	439	definition classification —————	159	51
review of — of map manuscript	5811-2	407	delineation —————	546	392
Tolerances			Triangulation		
equivalents table 5 1 —————	5411	331	definition classification —————	159	51
radial plotting, tilt, relief scale	4211	282	delineation —————	546	392
Topographic			delineation —————	{224	72
delineation on — maps and map			Trimetrogon —————	192	526
manuscripts			camera arrangement illustration	fig 9 1	526
alongshore physical features	{5423	342	coverage of photographs utilized		
marsh —————	fig 5 6b	341	illustration —————	fig 9 3	527
physical features —————	5423Ca	343	photograph arrangement illustra		
sand and gravel —————	543c	353	tion —————	fig 9 9	527
woodland —————	5433Ba	365	Rectoblique plotter —————	923	533
drafting scales instruments	5433Aa	364	Sketchmasters —————	{922	529
expression of contour lines	141b	20	Wilson photoalidade —————	{375	249
maps and map manuscripts	5432D	359	True (section) corner definition	921	528
flight planning for —————	15	31	delineation —————	5453De	389
hachures on —————	3241	120	Tunnel		
layouts —————	5432Fb	363	mine — opening symbol —————	fig 5 35	428
names —————	1533	37	load railroad symbol —————	fig 5 32	425
plane of reference for elevations	1535	39	Turns aerial photography instruc		
smooth drafting —————	5424A	346	tions —————	2414	89
transfer of details from concur	855	514	24 mile tracts public land surveys	fig 5 33	427
rent shoreline manuscripts	541	330	subdivision into town	{5453Cb	384
point			ships definition —————	fig 5 10	383
definition and classification	159	51	Types of aerial photographs	263	98
symbol —————	fig 5 41	434	Types of filters aerial photography	2262	76
station					
definition and classification	159	51			
delineation —————	5463	394			
descriptions filed in Washington					
Office —————	8225	499			
review of — on map manuscript	5811-6	407			
surveys comparison of map manu					
script with —————	8431	506			
Topography Instructions for (see					
also Project instructions)	151	32			
Top secret classified data	155	45			
Tops saddles hills delineation of					
contours —————	5432Db	360			
Township					
definition of —————	5453Cc	384			
line					
definition of —————	545	378			
symbol —————	fig 5 44	437			
public land surveys —————	5453Cc	384			
range designations — and	{5453Dd	389			
— —————	fig 5 13	390			
Subdivided into sections	5453Cd	385			
subdivision from a 24 mile tract	{5453Cb	384			
— —————	fig 5 10	383			
Tracing stand, multiplex	631	461			
Traffic circle					
delineation of —————	5441	368			
symbol —————	fig 5 32	425			
Trails					
delineation of —————	5441	366			

U

Ultra wide angle lens	3241	118
Unchecked spot elevations delinea-		
tion of —————	5467	396
Underpass		
definition delineation —————	5493B	371
symbol —————	fig 5 32	425
Unequally tilted photographs stereo		
scopic effect —————	3337	150
Universal sl etchmaster —————	9222	532
Universal transverse Mercator grid	413	267
Upper side of a tilted photograph	341	159
Urban areas		
buildings to be mapped within	5446F	375
definition of —————	5446F	375
interpretation of —————	5232B	326
Limits of —————	5446Fa	376
Open areas within —————	5446Fb	377
Use of		
component angles in rectification	366	213
drafting instruments —————	511	317
Drafting pens —————	5111	317
Steel pen points —————	5112	317
Utility drawing board	{1421	23
— —————	fig 1 7	22

	Reference No	Page
Utility table for field office use.....	1421	23
	<i>fig 1 8</i>	23
Utilized coverage of trimetrogon photogrammetry .....	92	526
	<i>fig 9 3</i>	527

V

Vectograph, polaroid stereoscopy.....	332	142
Vegetation		
interpretation of .....	5231C	323
marine — delineation of.....	5423L	342
swamp limits, <i>symbols</i> .....	<i>fig 9 36</i>	429
Verification of field edit collections.....	5914	413
Verification of smooth drafting.....	856	514
Veiner acuity of the human eye.....	331	141
Vertical		
accuracy (see Manuscript accuracy)		
compilation report — of.....	7261	493
Aerial photograph the — .....	32	107
Analytic problems .....	327	136
Comparison of a photograph with a map.....	321	107
Parallax and elevations.....	326	131
Relief displacement.....	323	114
Scale focal length and flying height.....	322	108
Theory of flight planning.....	324	117
Theory of radial plotting.....	325	126
angles		
horizontal photographs — .....	3713	228
from graphic .....	<i>fig 3 5 3</i>	227
oblique photographs — from .....	3733	243
graphic .....	<i>fig 3 6 0</i>	244
control		
delineation of — points.....	546	392
field inspection report.....	721	488
Instructions pertaining to — .....	1515	93
multiplex — for.....	1595	56
planetable — for.....	631	464
point station definition classification.....	1594	55
Reading plotter — for.....	159	51
<i>symbols</i> .....	1596	56
photograph (see also Vertical actual) .....	6243	467
<i>fig 5 4 2</i>	435	435
sletchmaster .....	9221	107
<i>fig 9 5</i>	530	530
<i>fig 9 5</i>	531	531
Viniduct		
definition of .....	5443	370
delineation of .....	5443A	370
<i>symbol</i> .....	<i>fig 5 3 2</i>	425
Viewing distance effect of stereoscopy .....	3332	145
Vineyard		
delineation of .....	5433A	364
<i>symbol</i> .....	<i>fig 5 3 7</i>	430
Vinylite drafting base (see also Plastic sheeting) .....	4131	267
Reading plotters — for.....	6244h	460
Vision persistence of human .....	331	141
Vitaceous humor of the human eye.....	331	140

W

Walls sea delineation of .....	5425N	352
Wandering (floating) mark stereoscopy .....	335	155
Wash drainage		
delineation of .....	5431G	356
<i>symbol</i> .....	<i>fig 5 2 5</i>	418
Washington Office		
files (see also Files) .....	822	498
Review (see also Review).....	84	505
Cartographic comparison .....	841	505
Descriptive report study .....	843	506
General Statement .....	842	506
Geographic names .....	841	505
Hydrography .....	845	509
Preparation for smooth drafting .....	846	510
Review report and registration.....	844	509
<i>fig 5 10</i>	847	510

	Reference No	Page
Washington Office—Continued		
Review and completion .....	8	497
General statement .....	81	497
Map revision .....	88	517
Office inspection of map manu script .....	83	504
outline of procedures .....	811	497
Project completion .....	86	515
Records and published maps .....	87	515
Review Washington Office .....	84	505
Routing and disposal of photographic records .....	82	498
grammetric records .....	821	498
Smooth drafting and publication .....	85	512
Water		
features		
delineation of — .....	5431	353
Cranberry bogs and salt evaporators .....	5431C	355
Glaciers and permanent snow or ice fields .....	5431F	356
Lakes and ponds .....	5431B	355
Marshes and swamps .....	5431D	355
Miscellaneous physical features .....	5431H	356
Rivers and streams .....	5431A	354
Springs .....	5431E	356
Washes .....	5431G	356
review of — on map manuscript .....	5811-20	409
line mean high — interpretation .....	5231D	324
<i>symbols</i> .....	<i>fig 5 2 2</i>	415
Wavelength of light relative to color .....	2261	75
Weather		
aerial photographic — .....	2121	59
map .....	<i>fig 2 1</i>	60
Weights (widths) of lines on map manuscript .....	541	330
Well <i>symbol</i>		
water .....	<i>fig 5 2 6</i>	419
gas or oil .....	<i>fig 5 3 4</i>	427
Wet plate negatives map reproduction .....	852	512
Wharf		
definition delineation .....	5425M	352
<i>symbol</i> .....	<i>fig 5 2 7</i>	420
Wide angle		
aerial camera .....	221	61
lens .....	319	107
<i>fig 3 2 4 1</i>	3241	118
Widths (weights) of lines delineation of features .....	541	330
Wild Autograph stereoscopic plotter .....	61	442
Williamson multiplex .....	61	442
Wilson photohade .....	371	224
<i>fig 3 5 6</i>	921	528
<i>fig 5 2 8</i>	528	528
Wire symbol .....	5425O	353
Woodland		
delineation of .....	5433A	363
Planimetric maps — on.....	5433Ab	364
Shoreline maps — on.....	5433Ac	365
Topographic maps — on.....	5433Ad	364
field classification of .....	5433A	363
omission of symbol in urban areas .....	5433	363
<i>symbol</i> .....	<i>fig 5 3 7</i>	430
World aeronautical chart system .....	4134	269
grid used formulas construction.....	413	267
Wreel		
delineation of .....	5425O	353
<i>symbol</i> .....	<i>fig 5 2 3</i>	416
Writing a descriptive report.....	72	479

Y

Y parallax stereoscopy .....	345	174
floating mark and .....	335	155
orientation of photographs and .....	334	151
tilt — and .....	345	174

Z

Zeiss multiplex stereoptantometer .....	61	442
Zoo		
delineation of .....	5448B	378
<i>symbol</i> .....	<i>fig 5 3 3</i>	428