

## 17TH STREET CANAL

AUTHORIZED PLAN

	ITEM	UNIT	QUANTITY	UNIT COST	COST
I	DREDGING AND FLOOD PROTECTION				
	A. Lake to Hammond Hwy (Bucktown) STA. 537+74 to STA. 552+59				
	1. Dredging	CY	59,471	\$ 10.45	\$ 621,500
	2. Levee Degrading	CY	10,962	6.00	65,800
	3. Levee Raising	CY	0		0
	4. Orleans Tied-Back Wall	LF	120	3133.00	376,000
	5. Orleans Floodwall	LF	1,188	364.50	433,000
	6. Jefferson Tied-Back Wall	LF	1,238	1159.45	\$1,435,400
	SUBTOTAL.....				\$2,931,700
	B. Hammond Hwy to Veterans Hwy STA. 553+13 to 625+19				
	1. Dredging	CY	228,600	\$ 10.45	\$2,388,900
	2. Levee Degrading	CY	37,423	6.00	224,600
	3. Levee Raising	CY	7,500	6.00	45,000
	4. Orleans Floodwall	LF	7,206	297.10	2,140,900
	5. Jefferson Floodwall	LF	7,206	297.10	2,140,900
	SUBTOTAL.....				\$6,940,300
	C. Veterans Hwy to I-10 STA. 626+42 to 639+16				
	1. Dredging	CY	37,064	\$ 10.45	\$ 387,300
	2. Levee Degrading	CY	7,540	6.00	45,300
	3. Levee Raising	CY	1,910	6.00	11,500
	4. Orleans Floodwall	LF	1,274	231.25	294,600
	5. Jefferson Floodwall	LF	1,274	231.25	294,600
	SUBTOTAL.....				\$1,033,300
	D. I-10 to Pump Station STA. 639+83 to STA 671+25				
	1. Dredging	CY	92,186	\$ 10.45	\$ 963,400
	2. Levee Degrading	CY	19,386	6.00	116,300
	3. Levee Raising	CY	8,885	6.00	53,300
	SUBTOTAL.....				\$1,133,000
II	DEMOLITION				
	A. Existing Structures		Lump		\$ 100,000
	B. Existing Bucktown Pedestrian Bridge		Lump		30,000
	C. Existing Sheet Pile Walls	LF	18,060	Varies	633,900
III	NEW BUCKTOWN PEDESTRIAN BRIDGE		Lump		\$ 235,000
IV	NEW BIKE PATHS	SY	5,670	\$ 10.00	\$ 56,700
V	REBUILD ORPHEUM AVENUE	SY	1,417	\$ 35.30	\$ 50,000
VI	NEW BOAT SLIPS	EA	85	\$ 341.00	\$ 29,000
VII	MATS	SF	195,000	\$ 3.18	\$ 620,100
VIII	SEEDING		Lump		\$ 10,000
IX	MOBILIZATION & DEMOBILIZATION		Lump		\$ 50,000
TOTAL COST AUTHORIZED PLAN.....					\$13,853,000

17TH STREET CANAL

HIGH LEVEL PLAN

ITEM	UNIT	QUANTITY	UNIT COST	COST
I DREDGING AND FLOOD PROTECTION				
A. Lake to Hammond Hwy (Bucktown) STA. 537+74 to STA. 552+59				
1. Dredging	CY	59,471	\$ 10.45	\$ 621,500
2. Levee Degrading	CY	10,962	6.00	65,800
3. Levee Raising	CY	0		0
4. Orleans Tied-Back Wall	LF	120	3133.00	376,000
5. Orleans T-Wall	LF	1,190	1195.80	1,423,000
6. Jefferson Tied-Back Wall	LF	1,238	1240.40	\$1,535,600
SUBTOTAL.....				\$4,021,900
B. Hammond Hwy to Veterans Hwy STA. 553+13 to 625+19				
1. Dredging	CY	228,600	\$ 10.45	\$2,388,900
2. Levee Degrading	CY	37,423	6.00	224,600
3. Levee Raising	CY	7,500	6.00	45,000
4. Orleans Floodwall	LF	7,206	732.20	5,276,300
5. Jefferson Floodwall	LF	7,206	732.20	5,276,300
SUBTOTAL.....				\$13,211,100
C. Veterans Hwy to I-10 STA. 626+42 to 639+16				
1. Dredging	CY	37,064	\$ 10.45	\$ 387,300
2. Levee Degrading	CY	7,540	6.00	45,300
3. Levee Raising	CY	1,910	6.00	11,500
4. Orleans Floodwall	LF	1,274	346.85	441,900
5. Jefferson Floodwall	LF	1,274	346.85	441,900
SUBTOTAL.....				\$1,327,900
D. I-10 to Pump Station STA. 639+83 to STA 671+25				
1. Dredging	CY	92,186	\$ 10.45	\$ 963,400
2. Levee Degrading	CY	19,386	6.00	116,300
3. Levee Raising	CY	8,885	6.00	53,300
4. Orleans Floodwall	LF	3,081	229.70	707,700
5. Jefferson Floodwall	LF	3,040	229.70	698,300
SUBTOTAL.....				\$2,539,000
II DEMOLITION				
A. Existing Structures		Lump		\$ 100,000
B. Existing Bucktown Pedestrian Bridge		Lump		30,000
C. Existing Sheet Pile Walls	LF	18,060	Varies	633,900
III NEW BUCKTOWN PEDESTRIAN BRIDGE		Lump		\$ 235,000
IV NEW BIKE PATHS	SY	5,670	\$ 10.00	\$ 56,700
V REBUILD ORPHEUM AVENUE	SY	1,417	\$ 35.30	\$ 50,000
VI NEW BOAT SLIPS	EA	85	\$ 341.00	\$ 29,000
VII MATS	SF	195,000	\$ 3.18	\$ 620,100
VIII SEEDING		Lump		\$ 10,000
IX MOBILIZATION & DEMOBILIZATION		Lump		\$ 50,000
TOTAL COST HIGH LEVEL PLAN.....				\$22,914,600

17TH STREET CANAL

LOW LEVEL PLAN WITH HIGH LEVEL SHEET PILE

ITEM	UNIT	QUANTITY	UNIT COST	COST
I DREDGING AND FLOOD PROTECTION				
A. Lake to Hammond Hwy (Bucktown) STA. 537+74 to STA. 552+59				
1. Dredging	CY	59,471	\$ 10.45	\$ 621,500
2. Levee Degrading	CY	10,962	6.00	65,800
3. Levee Raising	CY	0		0
4. Orleans Tied-Back Wall	LF	120	3133.00	376,000
5. Orleans Floodwall With T-Wall Sheetpile)	LF	1,188	545.95	648,600
6. Jefferson Tied-Back Wall	LF	1,238	1159.45	\$1,435,400
SUBTOTAL.....				\$3,147,300
B. Hammond Hwy to Veterans Hwy STA. 553+13 to 625+19				
1. Dredging	CY	228,600	\$ 10.45	\$2,388,900
2. Levee Degrading	CY	37,423	6.00	224,600
3. Levee Raising	CY	7,500	6.00	45,000
4. Orleans Floodwall	LF	7,206	652.55	4,702,300
5. Jefferson Floodwall	LF	7,206	652.55	4,702,300
SUBTOTAL.....				\$12,063,100
C. Veterans Hwy to I-10 STA. 626+42 to 639+16				
1. Dredging	CY	37,064	\$ 10.45	\$ 387,300
2. Levee Degrading	CY	7,540	6.00	45,300
3. Levee Raising	CY	1,910	6.00	11,500
4. Orleans Floodwall	LF	1,274	263.10	335,200
5. Jefferson Floodwall	LF	1,274	263.10	335,200
SUBTOTAL.....				\$1,114,500
D. I-10 to Pump Station STA. 639+83 to STA 671+25				
1. Dredging	CY	92,186	\$ 10.45	\$ 963,400
2. Levee Degrading	CY	19,386	6.00	116,300
3. Levee Raising	CY	8,885	6.00	53,300
SUBTOTAL.....				\$1,133,000
II DEMOLITION				
A. Existing Structures		Lump		\$ 100,000
B. Existing Bucktown Pedestrian Bridge		Lump		30,000
C. Existing Sheet Pile Walls	LF	18,060	Varies	633,900
III NEW BUCKTOWN PEDESTRIAN BRIDGE		Lump		\$ 235,000
IV NEW BIKE PATHS	SY	5,670	\$ 10.00	\$ 56,700
V REBUILD ORPHEUM AVENUE	SY	1,417	\$ 35.30	\$ 50,000
VI NEW BOAT SLIPS	EA	85	\$ 341.00	\$ 29,000
VII MATS	SF	195,000	\$ 3.18	\$ 620,100
VIII SEEDING		Lump		\$ 10,000
IX MOBILIZATION & DEMOBILIZATION		Lump		\$ 50,000
TOTAL COST AUTHORIZED PLAN WITH HIGH LEVEL SHEETPILE.....				\$19,272,600

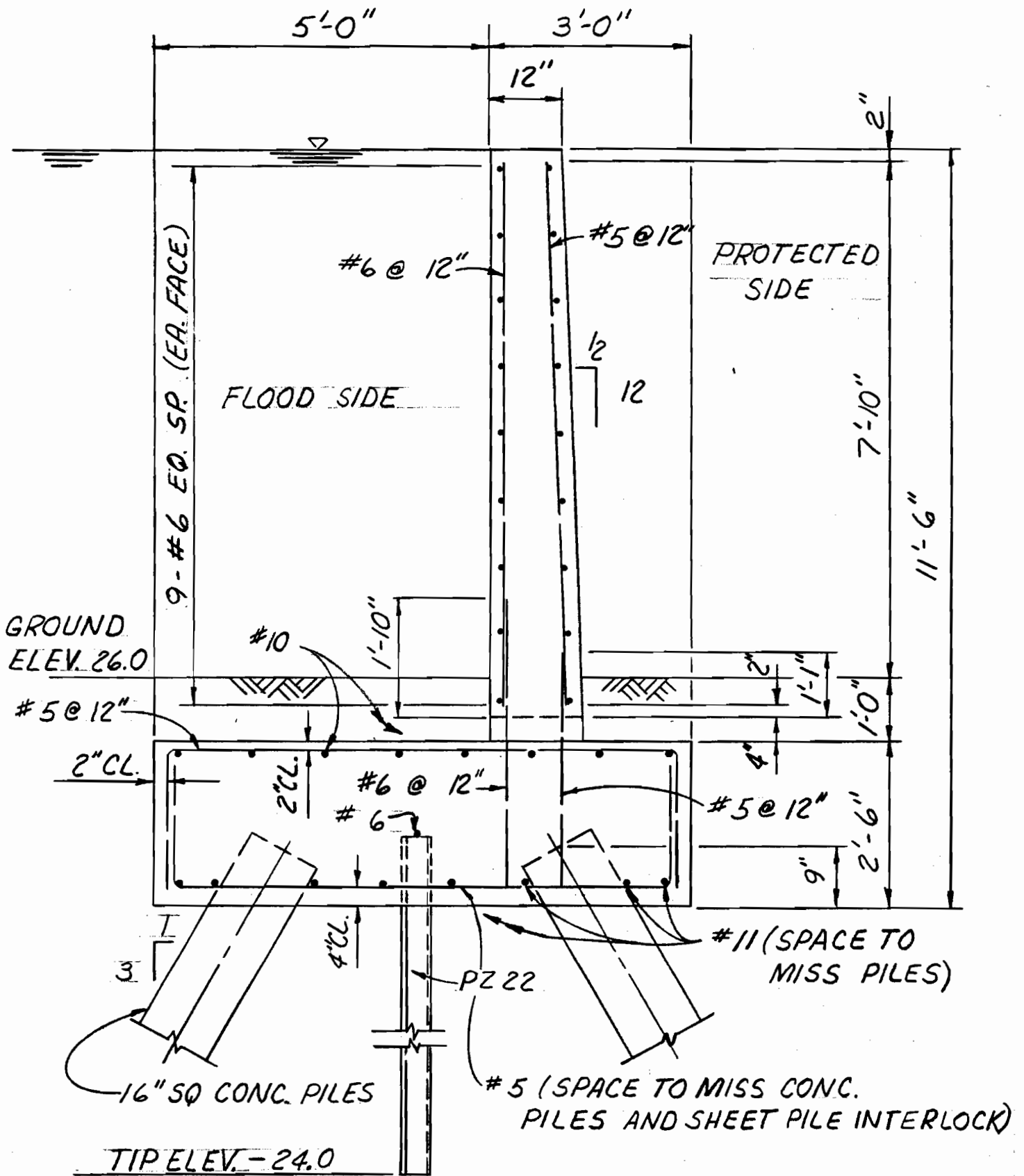

"T" WALL

SCALE = 1/2" = 1'-0"

17TH STREET CANAL

AUTHORIZED PLAN

ITEM	UNIT	QUANTITY	UNIT COST	COST
I DREDGING AND FLOOD PROTECTION				
A. Lake to Hammond Hwy (Bucktown) STA. 537+74 to STA. 552+59				
1. Dredging	CY	59,471	\$ 10.45	\$ 621,500
2. Levee Degrading	CY	10,962	6.00	65,800
3. Levee Raising	CY	0		0
4. Orleans Tied-Back Wall	LF	120	3133.00	376,000
5. Orleans Floodwall	LF	1,188	364.50	433,000
6. Jefferson Tied-Back Wall	LF	1,238	1159.45	\$1,435,400
SUBTOTAL.....				\$2,931,700
B. Hammond Hwy to Veterans Hwy STA. 553+13 to 625+19				
1. Dredging	CY	228,600	\$ 10.45	\$2,388,900
2. Levee Degrading	CY	37,423	6.00	224,600
3. Levee Raising	CY	7,500	6.00	45,000
4. Orleans Floodwall	LF	7,206	297.10	2,140,900
5. Jefferson Floodwall	LF	7,206	297.10	2,140,900
SUBTOTAL.....				\$6,940,300
C. Veterans Hwy to I-10 STA. 626+42 to 639+16				
1. Dredging	CY	37,064	\$ 10.45	\$ 387,300
2. Levee Degrading	CY	7,540	6.00	45,300
3. Levee Raising	CY	1,910	6.00	11,500
4. Orleans Floodwall	LF	1,274	231.25	294,600
5. Jefferson Floodwall	LF	1,274	231.25	294,600
SUBTOTAL.....				\$1,033,300
D. I-10 to Pump Station STA. 639+83 to STA 671+25				
1. Dredging	CY	92,186	\$ 10.45	\$ 963,400
2. Levee Degrading	CY	19,386	6.00	116,300
3. Levee Raising	CY	8,885	6.00	53,300
SUBTOTAL.....				\$1,133,000
II DEMOLITION				
A. Existing Structures		Lump		\$ 100,000
B. Existing Bucktown Pedestrian Bridge		Lump		30,000
C. Existing Sheet Pile Walls	LF	18,060	Varies	633,900
III NEW BUCKTOWN PEDESTRIAN BRIDGE		Lump		\$ 235,000
IV NEW BIKE PATHS	SY	5,670	\$ 10.00	\$ 56,700
V REBUILD ORPHEUM AVENUE	SY	1,417	\$ 35.30	\$ 50,000
VI NEW BOAT SLIPS	EA	85	\$ 341.00	\$ 29,000
VII MATS	SF	195,000	\$ 3.18	\$ 620,100
VIII SEEDING		Lump		\$ 10,000
IX MOBILIZATION & DEMOBILIZATION		Lump		\$ 50,000
TOTAL COST AUTHORIZED PLAN.....				\$13,853,000

17TH STREET CANAL

HIGH LEVEL PLAN

ITEM	UNIT	QUANTITY	UNIT COST	COST
I DREDGING AND FLOOD PROTECTION				
A. Lake to Hammond Hwy (Bucktown) STA. 537+74 to STA. 552+59				
1. Dredging	CY	59,471	\$ 10.45	\$ 621,500
2. Levee Degrading	CY	10,962	6.00	65,800
3. Levee Raising	CY	0		0
4. Orleans Tied-Back Wall	LF	120	3133.00	376,000
5. Orleans T-Wall	LF	1,190	1195.80	1,423,000
6. Jefferson Tied-Back Wall	LF	1,238	1240.40	\$1,535,600
SUBTOTAL.....				\$4,021,900
B. Hammond Hwy to Veterans Hwy STA. 553+13 to 625+19				
1. Dredging	CY	228,600	\$ 10.45	\$2,388,900
2. Levee Degrading	CY	37,423	6.00	224,600
3. Levee Raising	CY	7,500	6.00	45,000
4. Orleans Floodwall	LF	7,206	732.20	5,276,300
5. Jefferson Floodwall	LF	7,206	732.20	5,276,300
SUBTOTAL.....				\$13,211,100
C. Veterans Hwy to I-10 STA. 626+42 to 639+16				
1. Dredging	CY	37,064	\$ 10.45	\$ 387,300
2. Levee Degrading	CY	7,540	6.00	45,300
3. Levee Raising	CY	1,910	6.00	11,500
4. Orleans Floodwall	LF	1,274	346.85	441,900
5. Jefferson Floodwall	LF	1,274	346.85	441,900
SUBTOTAL.....				\$1,327,900
D. I-10 to Pump Station STA. 639+83 to STA 671+25				
1. Dredging	CY	92,186	\$ 10.45	\$ 963,400
2. Levee Degrading	CY	19,386	6.00	116,300
3. Levee Raising	CY	8,885	6.00	53,300
4. Orleans Floodwall	LF	3,081	229.70	707,700
5. Jefferson Floodwall	LF	3,040	229.70	698,300
SUBTOTAL.....				\$2,539,000
II DEMOLITION				
A. Existing Structures		Lump		\$ 100,000
B. Existing Bucktown Pedestrian Bridge		Lump		30,000
C. Existing Sheet Pile Walls	LF	18,060	Varies	633,900
III NEW BUCKTOWN PEDESTRIAN BRIDGE		Lump		\$ 235,000
IV NEW BIKE PATHS	SY	5,670	\$ 10.00	\$ 56,700
V REBUILD ORPHEUM AVENUE	SY	1,417	\$ 35.30	\$ 50,000
VI NEW BOAT SLIPS	EA	85	\$ 341.00	\$ 29,000
VII MATS	SF	195,000	\$ 3.18	\$ 620,100
VIII SEEDING		Lump		\$ 10,000
IX MOBILIZATION & DEMOBILIZATION		Lump		\$ 50,000
TOTAL COST HIGH LEVEL PLAN.....				\$22,914,600

17TH STREET CANAL

LOW LEVEL PLAN WITH HIGH LEVEL SHEET PILE

ITEM	UNIT	QUANTITY	UNIT COST	COST
<b>I DREDGING AND FLOOD PROTECTION</b>				
A. Lake to Hammond Hwy (Bucktown) STA. 537+74 to STA. 552+59				
1. Dredging	CY	59,471	\$ 10.45	\$ 621,500
2. Levee Degrading	CY	10,962	6.00	65,800
3. Levee Raising	CY	0		0
4. Orleans Tied-Back Wall	LF	120	3133.00	376,000
5. Orleans Floodwall With T-Wall Sheetpile)	LF	1,188	545.95	648,600
6. Jefferson Tied-Back Wall	LF	1,238	1159.45	\$1,435,400
SUBTOTAL.....				\$3,147,300
B. Hammond Hwy to Veterans Hwy STA. 553+13 to 625+19				
1. Dredging	CY	228,600	\$ 10.45	\$2,388,900
2. Levee Degrading	CY	37,423	6.00	224,600
3. Levee Raising	CY	7,500	6.00	45,000
4. Orleans Floodwall	LF	7,206	652.55	4,702,300
5. Jefferson Floodwall	LF	7,206	652.55	4,702,300
SUBTOTAL.....				\$12,063,100
C. Veterans Hwy to I-10 STA. 626+42 to 639+16				
1. Dredging	CY	37,064	\$ 10.45	\$ 387,300
2. Levee Degrading	CY	7,540	6.00	45,300
3. Levee Raising	CY	1,910	6.00	11,500
4. Orleans Floodwall	LF	1,274	263.10	335,200
5. Jefferson Floodwall	LF	1,274	263.10	335,200
SUBTOTAL.....				\$1,114,500
D. I-10 to Pump Station STA. 639+83 to STA 671+25				
1. Dredging	CY	92,186	\$ 10.45	\$ 963,400
2. Levee Degrading	CY	19,386	6.00	116,300
3. Levee Raising	CY	8,885	6.00	53,300
SUBTOTAL.....				\$1,133,000
<b>II DEMOLITION</b>				
A. Existing Structures		Lump		\$ 100,000
B. Existing Bucktown Pedestrian Bridge		Lump		30,000
C. Existing Sheet Pile Walls	LF	18,060	Varies	633,900
<b>III NEW BUCKTOWN PEDESTRIAN BRIDGE</b>		Lump		\$ 235,000
<b>IV NEW BIKE PATHS</b>	SY	5,670	\$ 10.00	\$ 56,700
<b>V REBUILD ORPHEUM AVENUE</b>	SY	1,417	\$ 35.30	\$ 50,000
<b>VI NEW BOAT SLIPS</b>	EA	85	\$ 341.00	\$ 29,000
<b>VII MATS</b>	SF	195,000	\$ 3.18	\$ 620,100
<b>VIII SEEDING</b>		Lump		\$ 10,000
<b>IX MOBILIZATION &amp; DEMOBILIZATION</b>		Lump		\$ 50,000
<b>TOTAL COST AUTHORIZED PLAN WITH HIGH LEVEL SHEETPILE.....</b>				<b>\$19,272,600</b>

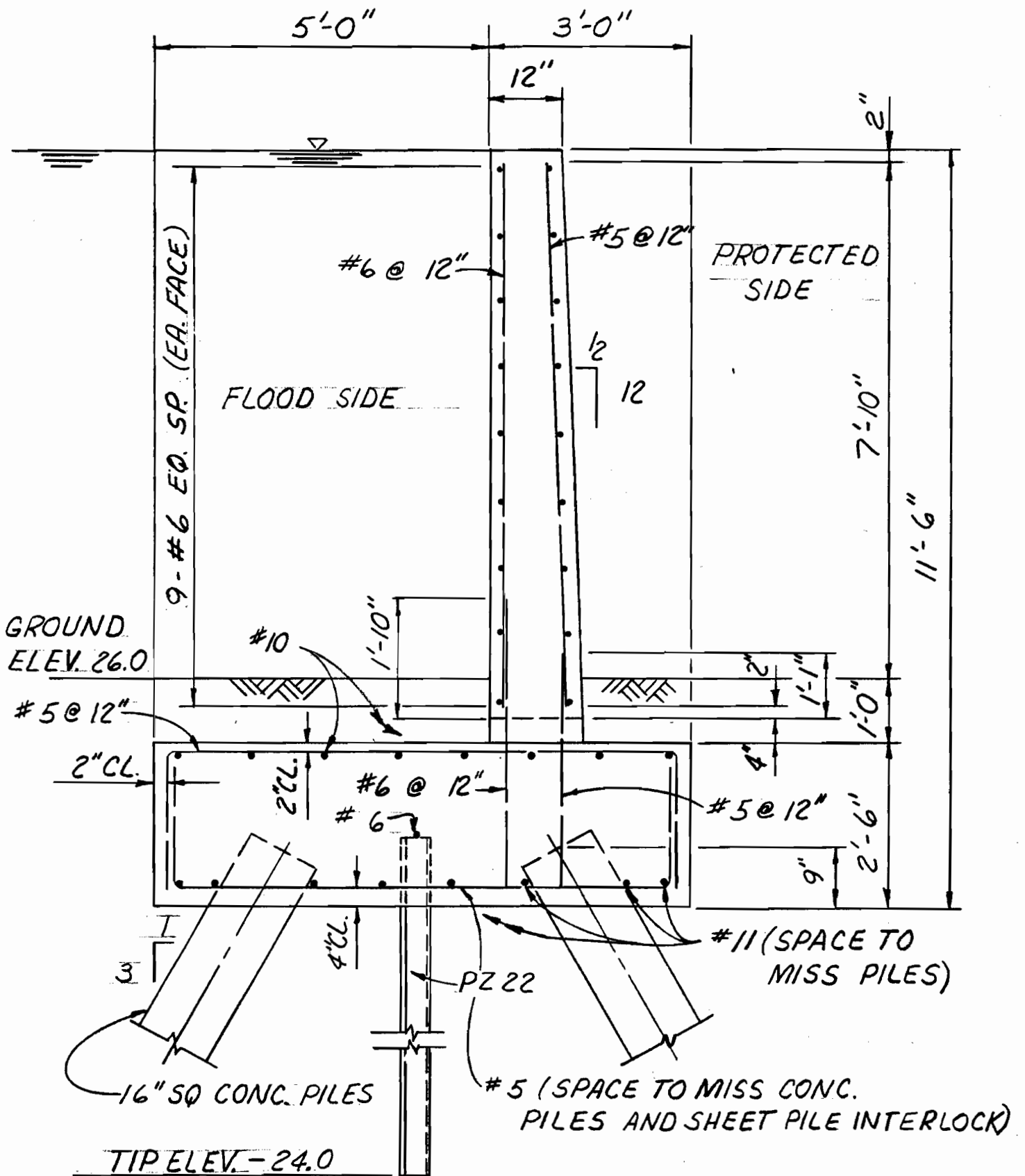

"T" WALL  
 SCALE = 1/2" = 1'-0"