

FLOOD CONTROL  
MISSISSIPPI RIVER AND TRIBUTARIES  
MISSISSIPPI RIVER LEVEES

ITEM M-94.3-R  
ALGIERS POINT SETBACK,  
LEVEE ENLARGEMENT  
AND SLOPE PAVEMENT

LORLEANS PARISH, LOUISIANA  
RELOCATION OF FACILITIES  
DESIGN MEMORANDUM NO. 57



DEPARTMENT OF THE ARMY  
NEW ORLEANS DISTRICT, CORPS OF ENGINEERS  
NEW ORLEANS, LOUISIANA

*DYNIX #286633*

JULY 1979

Serial No. 16

*TC  
7  
.07  
dm  
57  
1979*



DEPARTMENT OF THE ARMY  
NEW ORLEANS DISTRICT, CORPS OF ENGINEERS  
P. O. BOX 60267  
NEW ORLEANS, LOUISIANA 70160

REPLY TO  
ATTENTION OF:

LMNED-MR

8 August 1979

SUBJECT: Flood Control, Mississippi River and Tributaries, Mississippi River Levees, Item M-94.3-R, Algiers Point Levee Setback, Enlargement and Concrete Slope Pavement, Orleans Parish, Louisiana, Relocation of Facilities, Design Memorandum No. 57.

President  
Mississippi River Commission  
ATTN: MSRC-ED-TD

1. The subject design memorandum is submitted herewith for review and approval in accordance with the provisions of ER 1110-2-1150 dated 19 June 1970.
2. The final Environmental Impact Statement (EIS) for the Mississippi River Levees and Channel Improvements projects, which includes the Algiers Point Levee Setback, Enlargement and Concrete Slope Pavement, was filed with the Council on Environmental Quality (CEQ) on 9 April 1976, and the notice of its availability was published in the Federal Register on 16 April 1976. No inadequacies in the EIS were reported.
3. A cultural resources survey will be conducted concurrent with levee construction. The purpose of the cultural resources survey will be to ascertain the existence of archaeological resources in the work area and to determine the applicable procedures to be followed to avoid damage to the archaeological resources, if any are found. Additionally, specifications covering the work to be performed in constructing and maintaining the levees provide for preservation of any items of apparent historical or archaeological interest which may be discovered in the course of construction activities. The specifications will require immediate notification of proper authorities if any items of this nature are encountered, and will further require that the work cease until the items can be classified and salvaged, if salvage is considered appropriate.

LMNED-MR

8 August 1979

SUBJECT: Flood Control, Mississippi River and Tributaries, Mississippi River Levees, Item M-94.3-R, Algiers Point Levee Setback, Enlargement and Concrete Slope Pavement, Orleans Parish, Louisiana, Relocation of Facilities, Design Memorandum No. 57.

4. The Section 404 public notice for this reach of levee (Orleans Levee District) was issued on 20 October 1976. No adverse comments were received. In compliance with applicable regulations pursuant to Section 404(b) of Federal Water Pollution Control Act, a statement of findings covering proposed future construction of Mississippi River levees within the New Orleans District was submitted to the Environmental Protection Agency (EPA) on 14 July 1978. The statement of findings was approved on 6 November 1978.

5. Funds in the amount of \$500,000 (construction funds) were scheduled for obligation and expenditure for utility relocations in FY79. It is now estimated that only \$46,000 will be obligated and expended for all utility relocations in the enlargement reaches (construction funds). In the maintenance program, \$163,000 was scheduled for obligation and \$171,000 was scheduled for expenditure for relocations in FY79. It is now estimated that \$181,000 will be obligated and expended in FY79. The balance of maintenance funds (approximately \$401,000) will be obligated and expended in FY80. Levee construction is estimated to begin in October 1979 (FY80) and to be completed in FY82. This schedule is not expected to have an adverse impact on the overall Mississippi River Levees estimated project completion date.

1 Incl (11 sets)  
Design Memorandum No. 57

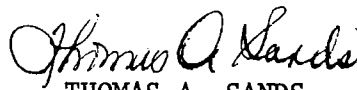
  
THOMAS A. SANDS  
Colonel, CE  
District Engineer

FLOOD CONTROL, MISSISSIPPI RIVER AND TRIBUTARIES

MISSISSIPPI RIVER LEVEES

ITEM M-94.3-R

ALGIERS POINT SETBACK, LEVEE ENLARGEMENT AND SLOPE PAVEMENT

ORLEANS PARISH, LOUISIANA

RELOCATION OF FACILITIES

DESIGN MEMORANDUM NO. 57

STATUS OF DESIGN MEMORANDUMS

<u>Design Memo No.</u>	<u>Title</u>	<u>Actual (A) or Scheduled (S) Submission Date</u>
1	Flood Control, Mississippi River and Tributaries, Item M-25.0-R, Buras Levee Setback, Plaquemines Parish, Louisiana, Relocation of Facilities	23 Nov 70 (A)
2	Flood Control, Mississippi River and Tributaries, Item M-26.0-R, Upper Buras Levee Setback, Plaquemines Parish, Louisiana, Relocation of Facilities	21 Jan 71 (A)
3	Flood Control, Mississippi River and Tributaries, Mississippi River Levees, Item M-14.9-R, Commander Levee Enlargement, Plaquemines Parish, Louisiana, Relocation of Facilities	11 Jun 71 (A)
4	Flood Control, Mississippi River and Tributaries, Mississippi River Levees, Item M-10.7-R, Venice Levee Enlargement and Setback, Plaquemines Parish, Louisiana, Relocation of Facilities	6 Apr 71 (A)
5	Lower Red River - South Bank Red River Levees, Item R-117.0-R (1957 Mileage), Levee Enlargement, Rapides-Cotton Bayou Levee, Rapides Parish, Louisiana, Relocation of Facilities	22 Jan 71 (A)
6	Flood Control, Mississippi River and Tributaries, Mississippi River Levees, Item M-31.3-R, Tropical Bend Levee Setback, Plaquemines Parish, Louisiana, Relocation of Facilities	30 Mar 71 (A)
7	Flood Control, Mississippi River and Tributaries, Mississippi River Levees, Item M-10.4-R, Lower Venice Levee Enlargement and Setback, Plaquemines Parish, Louisiana, Relocation of Facilities	27 Aug 71 (A)

STATUS OF DESIGN MEMORANDUMS (cont'd)

<u>Design Memo No.</u>	<u>Title</u>	<u>Actual (A) or Scheduled (S) Submission Date</u>
8	Flood Control, Mississippi River and Tributaries, Mississippi River Levees, Item M-18.9-R, Fort Jackson-Boothville Levee Enlargement, Plaquemines Parish, Louisiana, Relocation of Facilities	30 Nov 72 (A)
9	Flood Control, Mississippi River and Tributaries, Mississippi River Levees, Item M-21.5-R, Childress Levee Enlargement, Plaquemines Parish, Louisiana, Relocation of Facilities	23 Sep 71 (A)
10	Flood Control, Mississippi River and Tributaries, Mississippi River Levees, Item M-23.2-R, Buras-Triumph Levee Enlargement, Plaquemines Parish, Louisiana, Relocation of Facilities	31 May 73 (A)
11	Flood Control, Mississippi River and Tributaries, Mississippi River Levees, Item M-55.3-R, Upper Junior Levee Setback, Plaquemines Parish, Louisiana, Relocation of Facilities	21 Jun 71 (A)
12	Flood Control, Mississippi River and Tributaries, Mississippi River Levees, Item M-51.0-L, Gravolet Levee Enlargement and Setback, Plaquemines Parish, Louisiana, Relocation of Facilities	14 Sep 72 (A)
13	Flood Control, Mississippi River and Tributaries, Lower Red River - South Bank Red River Levees, Item R-123.5-R (1957 Mileage), Scott Home-Bertrand Levee Enlargement, Rapides Parish, Louisiana, Relocation of Facilities	15 Sep 72 (A)
14	Flood Control, Mississippi River and Tributaries, Mississippi River Levees, Item M-96.9-R, Amelia Street Levee, Jefferson Parish, Louisiana, Relocation of Facilities	31 Aug 71 (A)

STATUS OF DESIGN MEMORANDUMS (cont'd)

<u>Design Memo No.</u>	<u>Title</u>	<u>Actual (A) or Scheduled (S) Submission Date</u>
15	Flood Control, Mississippi River and Tributaries, Mississippi River Levees, Item M-41.7-R, Port Sulphur Levee Enlargement and Setback, Plaquemines Parish, Louisiana, Relocation of Facilities	28 Jan 74 (A)
16	Flood Control, Mississippi River and Tributaries, Mississippi River Levees, Item M-33.4-R, Nairn Levee Enlargement, Plaquemines Parish, Louisiana, Relocation of Facilities	22 Dec 75 (A)
17	Flood Control, Mississippi River and Tributaries, Mississippi River Levees, Item M-37.7-R, Homeplace Levee Enlargement, Plaquemines Parish, Louisiana, Relocation of Facilities	5 Jan 73 (A)
18	Flood Control, Mississippi River and Tributaries, Mississippi River Levees, Item M-57.7-R, Myrtle Grove Levee Enlargement, Plaquemines Parish, Louisiana, Relocation of Facilities	31 Jan 73 (A)
19	Flood Control, Mississippi River and Tributaries, Mississippi River Levees, Item M-28.0-R, Empire Levee Enlargement, Plaquemines Parish, Louisiana, Relocation of Facilities	30 Aug 74 (A)
20	Flood Control, Mississippi River and Tributaries, Mississippi River Levees, Item M-49.5-R, Woodland Levee Enlargement, Plaquemines Parish, Louisiana, Relocation of Facilities	24 Aug 73 (A)
21	Flood Control, Mississippi River and Tributaries, Mississippi River Levees, Item M-47.2-R, Nolan Levee Enlargement, Plaquemines Parish, Louisiana, Relocation of Facilities	29 Jun 73 (A)

STATUS OF DESIGN MEMORANDUMS (cont'd)

<u>Design Memo No.</u>	<u>Title</u>	<u>Actual (A) or Scheduled (S) Submission Date</u>
22	Flood Control, Mississippi River and Tributaries, Mississippi River Levees, Item M-45.0-R, Socola Levee Enlargement, Plaquemines Parish, Louisiana, Relocation of Facilities.	28 Nov 72 (A)
23	Flood Control, Mississippi River and Tributaries, Mississippi River Levees, Item M-75.0-L, Scarsdale Levee Setback, Plaquemines Parish, Louisiana, Relocation of Facilities	7 Dec 73 (A)
24	Flood Control, Mississippi River and Tributaries, Mississippi River Levees, Item M-89.5-R, Cutoff Levee Setback, Orleans Parish, Louisiana, Relocation of Facilities	20 Dec 74 (A)
25	Flood Control, Mississippi River and Tributaries, Mississippi River Levees, Item M-130.0-L, Gypsy Levee Setback, St. Charles Parish, Louisiana, Relocation of Facilities	30 Dec 74 (A)
26	Flood Control, Mississippi River and Tributaries, Atchafalaya River Levees, Item A-31.3-L, Cross Bayou Levee Setback, Pointe Coupee Parish, Louisiana, Relocation of Facilities	8 Nov 74 (A)
27	Flood Control, Mississippi River and Tributaries, Mississippi River Levees, Item M-39.0-R, Freeport Levee Enlargement, Plaquemines Parish, Louisiana	27 Dec 74 (A)
28	Flood Control, Mississippi River and Tributaries, Mississippi River Levees, Item M-30.2-R, Upper Empire Levee Enlargement and Setback, Plaquemines Parish, Louisiana, Relocation of Facilities	30 Apr 75 (A)



STATUS OF DESIGN MEMORANDUMS (cont'd)

<u>Design Memo No.</u>	<u>Title</u>	<u>Actual (A) or Scheduled (S) Submission Date</u>
29	Flood Control, Mississippi River and Tributaries, Mississippi River Levees, Item M-63.0-L, Monsecour Levee Enlargement, Plaquemines Parish, Louisiana, Relocation of Facilities	15 Oct 75 (A)
30	Flood Control, Mississippi River and Tributaries, Atchafalaya River Levees, Item A-25.5-R, Goudeau Levee Setback, St. Landry Parish, Louisiana, Relocation of Facilities	30 Jun 76 (A)
31	Flood Control, Mississippi River and Tributaries, Mississippi River Levees, Item M-320 to 303-R, Fifth Louisiana Levee District Levee Enlargement, Concordia, West Feliciana, and Pointe Coupee Parishes, Louisiana, Relocation of Facilities	30 Jun 75 (A)
32	Flood Control, Mississippi River and Tributaries, Atchafalaya River Levees, Item A-4.6-L, Legonier Levee Setback, Pointe Coupee Parish, Louisiana, Relocation of Facilities	30 Sep 75 (A)
33	Flood Control, Mississippi River and Tributaries, Mississippi River Levees, Item M-35.0-R, Nairn Levee Setback, Plaquemines Parish, Louisiana, Relocation of Facilities	22 Dec 75 (A)
34	Flood Control, Mississippi River and Tributaries, Mississippi River Levees, Item M-99.0-L, Louisiana Avenue Floodwall, Orleans Parish, Louisiana, Relocation of Facilities	21 Oct 75 (A)
35	Flood Control, Mississippi River and Tributaries, Mississippi River Levees, Item M-144.5-L, Angelina Levee Setback, Saint John the Baptist Parish, Louisiana, Relocation of Facilities	12 Dec 75 (A)

STATUS OF DESIGN MEMORANDUMS (cont'd)

<u>Design Memo No.</u>	<u>Title</u>	<u>Actual (A) or Scheduled (S) Submission Date</u>
36	Flood Control, Mississippi River and Tributaries, Mississippi River Levees, Item M-205.0-R, Point Pleasant Levee Setback, Iberville Parish, Louisiana, Relocation of Facilities	29 Nov 76 (A)
37	Flood Control, Mississippi River and Tributaries, Mississippi River Levees, Item M-58.0-L, St. Sophie Levee Enlargement, Plaquemines Parish, Louisiana, Relocation of Facilities	15 Sep 75 (A)
38	Flood Control, Mississippi River and Tributaries, Atchafalaya River Levees, Item A-38.0L, Holloway Lake Levee Setback, Pointe Coupee Parish, Louisiana, Relocation of Facilities	26 Mar 76 (A)
39	Flood Control, Mississippi River and Tributaries, Mississippi River Levees, Item M-90.5-L, Chalmette Slip Levee Enlargement, St. Bernard Parish, Louisiana, Relocation of Facilities	5 May 77 (A)
40	Flood Control, Mississippi River and Tributaries, Mississippi River Levees, Item M-95.3L, Thalia-Poydras Street Floodwall, Orleans Parish, Louisiana, Relocation of Facilities	10 Jun 76 (A)
41	Flood Control, Mississippi River and Tributaries, Mississippi River Levees, Item M-217.5-L, Chariot Levee Setback, East Baton Rouge Parish, Louisiana, Relocation of Facilities	11 Jun 76 (A)
42	Flood Control, Mississippi River and Tributaries, Mississippi River Levees, Item M-52.6-R and M-52.1-R Junior and Lower Junior Levee Setbacks, Plaquemines Parish, Louisiana, Relocation of Facilities	24 Jan 77 (A)

STATUS OF DESIGN MEMORANDUMS (cont'd)

<u>Design Memo No.</u>	<u>Title</u>	<u>Actual (A) or Scheduled (S) Submission Date</u>
43	Flood Control, Mississippi River and Tributaries, Mississippi River Levees, Item M-86.0-R, Stanton Levee Setback, Orleans Parish, Louisiana, Relocation of Facilities	10 Oct 78 (A) ✓
44	Flood Control, Mississippi River and Tributaries, Mississippi River Levees, Item M-215.3-L, Manchac Bend Levee Setback, East Baton Rouge Parish, Louisiana, Relocation of Facilities	23 Dec 76 (A)
45	Flood Control, Mississippi River and Tributaries, Mississippi River Levees, Item M-28.5-R, Empire Levee Setback, Plaquemines Parish Louisiana, Relocation of Facilities	16 Dec 77 (A)
46	Flood Control, Mississippi River and Tributaries, Mississippi River Levees, Item M-49.0-R, Woodland Levee Setback, Plaquemines Parish Louisiana, Relocation of Facilities	28 Nov 77 (A)
47	Flood Control, Mississippi River and Tributaries, Atchafalaya Basin Floodway, New Berwick Floodwall, St. Mary Parish, Louisiana, Relocation of Facilities	14 Mar 79 (A) ✓
48	Flood Control, Mississippi River and Tributaries, Atchafalaya Basin Floodway, New Morgan City Floodwall, St. Mary Parish, Louisiana, Relocation of Facilities	Dec 79 (S)
49	Flood Control, Mississippi River and Tributaries, Atchafalaya Basin Floodway, New Tiger Island Floodwall, St. Mary Parish, Louisiana, Relocation of Facilities	Aug 79 (A) ✓
50	Flood Control, Mississippi River and Tributaries, Mississippi River Levees, Item M-24.8-R, Buras-Triumph Levee Setback, Plaquemines Parish, Louisiana, Relocation of Facilities	30 Sep 77 (A)

STATUS OF DESIGN MEMORANDUMS (cont'd)

<u>Design Memo No.</u>	<u>Title</u>	<u>Actual (A) or Scheduled (S) Submission Date</u>
51	Flood Control, Mississippi River and Tributaries, East Atchafalaya Basin Protection Levee, Item E-69.0 and E-73.3, Levee Enlargements, St. Martin and Iberville Parishes, Louisiana, Relocation of Louisiana State Route 997	3 Jun 77 (A)
52	Flood Control, Mississippi River and Tributaries, Mississippi River Levees, Item M-100.0-L, Nashville-Napoleon Floodwall, Orleans Parish, Louisiana Relocation of Facilities	25 Aug 77 (A)
53	Flood Control, Mississippi River and Tributaries, Mississippi River Levees, Item M-88.0-R, Algiers Lock Forebay Levee Enlargement, Orleans Parish, Louisiana, Relocation of Facilities	1 Aug 77 (A)
54	Flood Control, Mississippi River and Tributaries, Mississippi River Levees, Item M-29.4-R, Empire Lock Modifications, Plaquemines Parish, Louisiana, Relocation of Facilities	19 May 78 (A)
55	Flood Control, Mississippi River and Tributaries, West Atchafalaya Basin Protection Levee, Item W-86.0 Levee Enlargement, St. Mary Parish, Louisiana, Relocation of Facilities	NOT SCHEDULED
56	Flood Control, Mississippi River and Tributaries, East Atchafalaya Basin Protection Levee, Item E-89, Driving Steel Sheet Piling and Levee Enlargement, St. Mary Parish, Louisiana, Relocation of Facilities	15 May 78 (A)
57	Flood Control, Mississippi River and Tributaries, Algiers Point Setback, Levee Enlargement and Slope Pavement, Item M-94.3-R, Orleans Parish, Louisiana Relocation of Facilities	Aug 79 (A)

STATUS OF DESIGN MEMORANDUMS (cont'd)

<u>Design Memo No.</u>	<u>Title</u>	<u>Actual (A) or Scheduled (S) Submission Date</u>
58	Flood Control, Mississippi River and Tributaries, Item M-48.7-L, East Pointe-a-la-Hache Ferry Landing and Levee Enlargement, Plaquemines Parish, Louisiana, Relocation of Facilities	2 Jun 78 (A)
59	Flood Control, Mississippi River and Tributaries, Jackson Avenue Floodgate, Item M-97.2-L, Orleans Parish, Louisiana, Relocation of Facilities	9 Jun 78 (A)
60	Flood Control, Mississippi River and Tributaries, Item M-303 to 293-R, Torras Levee Enlargement and Berm, Pointe Coupee Parish, Louisiana, Relocation of Facilities	26 Jul 78 (A)
61	Flood Control, Mississippi River and Tributaries, East Atchafalaya Basin Protection Levee, Item E-36.0, Levee Enlargement, Iberville Parish, Louisiana, Relocation of Facilities	Mar 79 (A) ✓
62	Flood Control, Mississippi River and Tributaries, Item M-293 to 283-R, Levee Raccourci Levee Enlargement, Pointe Coupee Parish, Louisiana, Relocation of Facilities	12 Jun 79 (A) ✓
63	Flood Control, Mississippi River and Tributaries, West Atchafalaya Basin Protection Levee, Item W-85, Levee Enlargement, St. Mary Parish, Louisiana, Relocation of Facilities	Dec 79 (S)

TABLE OF CONTENTS

<u>Paragraph</u>	<u>Title</u>	<u>Page</u>
	PERTINENT DATA	A
1	PURPOSE OF DESIGN MEMORANDUM	1
2	PROJECT AUTHORIZATION	1
	a. Construction, Enlargement, or Improvement of Main Line Mississippi River Levees	1
	b. Levee Setbacks, Main Line Mississippi River Levees	2
3	AUTHORITY FOR ACCOMPLISHING RELOCATIONS	2
4	DESCRIPTION OF FACILITIES AFFECTED BY THE PROJECT	3
	a. Enlargement Limits	3
	b. Setback Limits	9
5	OWNER'S COMPENSABLE INTEREST	16
	a. General	16
	b. Railroads	17
	c. Utilities and Structures	17
	d. Other Facilities	18
6	FIELD RECONNAISSANCE AND INVESTIGATION	19
7	CRITERIA FOR RELOCATED FACILITIES	19
	a. Roads	19
	b. Railroad	20
	c. Utilities and Structures	20
	d. Other Facilities	20
8	DESCRIPTION OF PROPOSED RELOCATIONS	20
	a. Enlargement Limits	20
	b. Setback Limits	26
9	PROCEDURE FOR ACCOMPLISHING RELOCATIONS	31
	a. Roads	31
	b. Railroads	31
	c. Utilities	32
10	ATTITUDE OF OWNERS	33
11	FACILITIES NOT AFFECTED	35
12	ESTIMATE OF COST	35
13	COMPARISON WITH PRIOR COST ESTIMATES	37
14	JUSTIFICATION FOR COST REVISION	39
15	RECOMMENDATIONS	40

TABLES

<u>No.</u>	<u>Title</u>	<u>Page</u>
1A	LIST OF EXISTING FACILITIES ENLARGEMENT LIMITS	C-1
1B	LIST OF EXISTING FACILITIES SETBACK LIMITS	C-4

PLATES

<u>No.</u>	<u>Title</u>
1	LOCATION MAP
2-5	PROJECT PLAN
6-8	TYPICAL SECTIONS
9, 10	CONCRETE SLOPE PAVEMENT, LEVEE CROWN, AND TOE TRENCH DETAILS
11	SETBACK III DETAILS
12, 13	SETBACK IV DETAILS

APPENDIXES

IA	ATTORNEY'S REPORT
IB	ATTORNEY'S REPORT
II	COST ESTIMATES

## PERTINENT DATA

### Location:

The Algiers Point Setback, Levee Enlargement and Slope Pavement, Item M-94.3-R, is located in Orleans Parish, Louisiana, on the right descending bank of the Mississippi River between levee stations 0+00 and 112+00 (approximate river miles 95 to 93 above the Head of Passes).

### Purpose:

The Mississippi River and Tributaries Flood Control project embodies a plan to protect the Lower Mississippi Valley against the project design flood. The plan includes the use of levees, floodways, channel improvements and major tributary flood control improvements. Specifically, item M-94.3-R is designed to provide flood protection to a portion of the greater New Orleans area.

### Authorization:

The Flood Control Act of 15 May 1928 (Public Law 391, 70th Congress), as amended, provides authorization for the project.



Local assuring agency:

The local assuring agency for the Algiers Point Setback, Levee Enlargement and Slope Pavement is the Board of Levee Commissioners of the Orleans Levee District.

Description:

The Algiers Point Setback, Levee Enlargement and Slope Pavement is a proposed improvement to a reach of mainline levee on the right descending bank of the Mississippi River in Orleans Parish, Louisiana. The proposed improvement consists of enlarging approximately 7800 linear feet of levee (primarily straddle and riverside enlargement) and of setting back four segments of levee totaling approximately 3800 linear feet, as shown on plates 2 thru 5. Unreinforced concrete slope pavement will be placed on the riverside slope of the levee. Design grade for the improved levee varies from 23.9 feet m.s.l. at the upstream limit of work to 23.2 feet m.s.l. at the downstream limit. Riverside and landside levee slopes will be 1 vertical on 3 horizontal and 1 vertical on 4 horizontal, respectively. The project area is highly encumbered by various major improvements (water intakes, sewer discharge lines, businesses, private dwellings, and other utilities). The levee alignment presented herein is the one which results in the least disruption of existing facilities while still achieving a minimum factor of safety of 1.3 for the authorized project design grade and section.

TABLE 1A  
LIST OF EXISTING FACILITIES  
ENLARGEMENT LIMITS

Item No.	Owner	Description	Disposition	Location
RR-1	Missouri-Pacific	Railroad Track	Remove	Plate 2
W-1	Sewerage and Water Board of New Orleans (S&WB)	30-inch-diameter Water Intake	Not Affected	Plate 2
W-2	S&WB	20-inch-diameter Water Intake	Not Affected	Plate 2
E-9	S&WB	2 Underground Power Cables	Relocate	Plate 3A
E-1	Louisiana Power & Light (LP&L)	2 Power Poles	Remove	Plate 2

C-1

C-2

Item No.	Owner	Description	Disposition	Location
E-1	Louisiana Power & Light (LP&L)	2 Power Poles	Remove	Plate 2
E-3	LP&L	Pole and attachments	Relocate	Plate 2
E-4	LP&L	Aerial Powerline	Remove	Plate 2
E-6	LP&L	Powerline & Poles	Relocate	Plate 3A
E-7	LP&L	Powerline & Poles	Relocate	Plate 3A
E-12	LP&L	Powerline & Poles	Relocate	Plate 4
E-13	LP&L	Powerline & Poles	Relocate	Plate 4
E-14	LP&L	Guy Pole and Anchors	Relocate	Plate 4
E-17	LP&L	Aerial Powerline	Not Affected	Plate 5
E-18	LP&L	Guy Poles and Anchors	Not Affected	Plate 5
E-19	LP&L	Guy Poles and Anchors	Relocate	Plate 5
E-2	Unknown	3 Power Poles	Remove	Plate 2
E-5	Unknown	3 Power Poles	Remove	Plate 2
T-1	South Central Bell Telephone (S.C.B.)	6 Buried Telephone Cables	Relocate	Plate 2
T-2	S.C.B.	Telephone Line	Relocate	Plate 3

Item No.	Owner	Description	Disposition	Location
T-4	S.C.B.	4 Underground Telephone Cables, Manhole, and Relay Boxes	Relocate	Plate 3
T-7	S.C.B.	Underground Telephone Cable	Relocate	Plate 4
T-8	S.C.B.	Telephone Line & Poles	Not Affected	Plate 4
P-1	Eastern Associates (E.A.)	Pipeline	Remove	Plate 2
G-1	E.A.	3-inch-diameter Gasline	Remove	Plate 3
W-3	E.A.	Small Diameter Waterline	Relocate	Plate 3A
CR-1	Algiers Iron Works (A.I.W.)	Crane Tracks	Remove	Plate 3
E-8	A.I.W.	Underground Power Cable	Relocate	Plate 3A
W-8	Board of Commissioners of the Port of New Orleans (Dock Board)	6-inch-diameter Waterline	Relocate	Plate 4
W-9	T. Smith & Sons	Small Diameter Waterline	Relocate	Plate 4
W-11	T. Smith & Sons	Small Diameter Waterline	Relocate	Plate 5

TABLE 1B  
LIST OF EXISTING FACILITIES  
SETBACK LIMITS

Item No.	Owner	Description	Disposition	Location
E-1	Louisiana Power & Light (LP&L)	2 Power Poles	Remove	Plate 2
E-7	LP&L	Powerline & Poles	Relocate	Plate 3A
E-10	LP&L	Powerline & Poles	Relocate	Plate 3A
E-11	LP&L	Powerline & Poles	Remove	Plate 4
E-15	LP&L	Powerline & Poles	Relocate	Plate 4
E-16	LP&L	Guy Pole & Attachment	Relocate	Plate 4
E-17	LP&L	Aerial Powerline	Not Affected	Plate 5
WW-1	Board of Commissioners of the Port of New Orleans (Dock Board)	Timber Walkway	Abandon	Plate 3

C-4

Item No.	Owner	Description	Disposition	Location
G-4	Dock Board	2-inch-diameter Gasline	Abandon	Plate 3
W-6	Dock Board	6-inch-diameter Waterline	Abandon	Plate 3A
W-7	Dock Board	6-inch-diameter Waterline	Relocate	Plate 3A
G-2	New Orleans Public Service, Inc. (NOPSI)	Gasmeter	Remove	Plate 3
G-5	NOPSI	2-inch-diameter Gasline	Remove	Plate 3
G-3	Algiers Iron Works (A.I.W.)	Gasline	Abandon	Plate 3
CR-1	A.I.W.	Crane Tracks	Remove	Plate 3
W-4	A.I.W.	Small Diameter Waterline	Relocate	Plate 3A

Item No.	Owner	Description	Disposition	Location
T-3	South Central Bell (S.C.B.)	Telephone Line	Relocate	Plate 3
T-5	S.C.B.	Telephone Line & Poles	Relocate	Plate 3
T-6	S.C.B.	Underground Telephone Cable	Remove	Plate 3
T-9	S.C.B.	Telephone Line	Relocate	Plate 4
T-10	S.C.B.	Aerial Telephone Cable	Relocate	Plate 5
R-1	City of New Orleans	Seguin St. and Patterson Drive	Relocate	Plate 3
W-5	Sewerage & Water Board of New Orleans (S.&W.B.)	6-inch-diameter Waterline	Relocate	Plate 3A
S-3	S.&W.B.	8-inch-diameter Sewerline	Relocate	Plate 3A

Item No.	Owner	Description	Disposition	Location
S-1	S.&W.B.	20-inch-diameter Sewer Outfall	Relocate	Plate 4
S-2	S.&W.B.	30-inch-diameter Sewer Outfall	Relocate	Plate 4
W-10	T. Smith & Sons	Small diameter Waterline	Relocate	Plate 4



1. PURPOSE OF DESIGN MEMORANDUM. The purpose of this design memorandum is to present the plans for the relocation and alteration of the facilities which will be affected by the construction of item M-94.3-R, Algiers Point Levee Enlargement and Setback, hereinafter referred to as the Algiers Point reach. It is being submitted in compliance with Part 3, Section LXXIII, ER 1180-1-1, dated 1 December 1969, and DIVR 1110-2-1, dated 29 January 1968. It establishes the necessity for the relocation of the facilities and the plans of relocations; it establishes the legal obligation of the Federal Government, and it will provide the basis for utilizing Federal funds in accomplishing the relocations described herein.

2. PROJECT AUTHORIZATION.

a. Construction, Enlargement, or Improvement of Main Line Mississippi River Levees.

Authority for construction, enlargement, or improvement of mainline Mississippi River Levees, including berms, is contained in the Act of 15 May 1928 (PL 391, 70th Congress) as amended. The furnishing of right-of-way for levee foundations and levees on the main stem Mississippi River, except levee setbacks, is an obligation of local interests (see Section 3, Act of 15 May 1928). The

replacement or relocation of public roads, highways, railroads, public utilities, and pipelines required for the construction of mainline Mississippi River Levees will be accomplished at Federal expense. Reimbursement of costs to local cooperating agencies in perfecting relocation of interfering facilities may be made pursuant to the Act of 23 April 1934 (PL 171, 73d Congress).

b. Levee Setbacks, Main Line Mississippi River Levees.

Authority for the construction of levee setbacks of mainline Mississippi River Levees is contained in the Act of 15 May 1928 (P 2 391, 70th Congress), as amended. Payment or reimbursement of costs to local cooperating agencies for rights-of-way furnished including necessary relocation or alteration of public roads, highways, railroads, public utilities, and pipelines is authorized by the Flood Control Act of 18 August 1941 (PL 228, 77th Congress, 1st Session), as amended by the Flood Control Act of 22 December 1944 (PL 534, 78th Congress, 2d Session).

3. AUTHORITY FOR ACCOMPLISHING RELOCATIONS. Policy for relocations is provided by DIVR 1110-2-1. The legal obligations of the Federal Government regarding the affected facilities and the extent of authority for the relocations are as established in the Attorney's Reports which are attached as Appendixes IA and IB.

4. DESCRIPTION OF FACILITIES AFFECTED BY THE PROJECT.

a. Enlargement Limits.

(1) Railroads. The Missouri-Pacific Railroad Company (MPRR) owns and operates a railroad spur track which serves as a switching track for the Perry Street Wharf in Algiers. The total length of this facility (item RR-1, plate 2) is 763 linear feet, 46 feet of which will be affected by the project. The affected segment of track is located within the existing levee right-of-way. Item RR-1 was installed in 1930, and it is in good condition.

(2) Utilities and Structures

(a) Sewerage and Water Board of New Orleans (S&WB). The Sewerage and Water Board owns and operates two high voltage (6600 volts each) submarine cables, which cross the levee at station 44+90 (plate 3A), and a switch box located adjacent to the landside levee toe. The cables and switch box, designated as item E-9, provide power for the operation of the water purification plant and three drainage pumping stations in Algiers. The total length of the two cables is approximately 60,000 feet, 350 feet of which will be affected by the project. The switch box will not be affected by the project. Item E-9 was installed in 1952, and it has an estimated design life of 100 years. Item E-9 is in good condition.

(b) The Board of Commissioners of the Port of New Orleans (Dock Board). The Dock Board owns and operates item W-8, a 6-inch-diameter waterline which crosses the levee at approximate station 64+40 (plate 4). Approximately 300 linear feet of this facility will be affected by the project. Item W-8 was installed in 1968, and it has a design life of 75 years. It is in good condition.

(c) South Central Bell Telephone Company (SCB).

(i) Item T-1. Item T-1 consists of three inactive submarine trunk cables and three active submarine trunk cables which cross the levee at station 22+85 (plate 2). Each of the active cables is approximately 19,000 feet in length and connects SCB's Main Central Office on the east bank of the river with the Riverside Central Office on the west bank. Approximately 150 linear feet of each cable (active and inactive) will be affected by the project. The ages of the active cables are 4 years (one cable) and one year (two cables), and the design life of each cable is 25 years. The active cables are in good condition.

(ii). Item T-2. Item T-2 is an aerial exchange cable which services Coyle Lines, Inc. on the batture opposite station 30+00 (plate 3). Approximately 150 linear feet of this facility will be affected by the project. The age of item T-2 is 18 years, and it has a design life of 35 years. Item T-2 is in good condition.

(iii) Item T-4. Item T-4 consists of four submarine trunk cables which cross the levee at station 44+30 (plate 3). Each cable is approximately 18,100 feet long and connects SCB's Main Central Office on the east bank of the river with the Riverside Central Office on the west bank. Item T-4 is also serviced by a 12 foot long by 6 foot wide by 7 foot high manhole located in the batture and adjacent to the floodside levee toe and by repeater (relay) terminals located adjacent to the landside levee toe. Approximately 150 linear feet of each cable, and the manhole will be affected by the project. The repeater terminals will not be affected by the project. The ages of the cables are 8, 11, 12 and 25 years. Item T-4 is in good condition.

(iv) Item T-7. Item T-7 is a submarine trunk cable which crosses the levee at station 72+85 (plate 4). This cable is approximately 19,800 feet long and connects the Franklin Central Office on the east bank of the river with the Riverside Central Office on the west bank. Approximately 150 feet of this facility will be affected by the project. The age of item T-7 is 17 years, and the design life is 25 years. It is in good condition.

(d) Louisiana Power and Light Company (LP&L). Louisiana Power and Light Company owns various facilities which are located within the project limits. The installation date of the LP&L facilities varies from 1962 to 1973 and design life is 30 years. The facilities are in good condition and are as follows:

(i) Item E-3. Item E-3 (plate 2) is a 45 foot timber pole with attachments located at approximate station 19+15. Item E-3 will require relocating outside of the levee right-of-way.

(ii) Item E-4. Item E-4 (plate 2) consists of an aerial power line which crosses over the levee at about station 22+96 and a 30 foot light standard located at station 24+28 on the landside of the levee. Approximately 130 linear feet of this facility and the light standard will be affected by the project.

(iii) Item E-6 Item E-6 (plate 3A) is a 40 foot timber pole with attachments located on inside of the right-of-way at station 30+10 and requires adjusting to accommodate the project.

(iv) Item E-7. Item E-7 (plate 3A) is a 13.8 kV aerial powerline located between stations 38+10 and 45+40 which services the Algiers Iron Works and Dry Dock Company and two private dwellings located on the floodside of the levee. Approximately 700 linear feet of this facility will be affected within the enlargement limits (station 39+43 to station 45+40).

(v) Item E-12. Item E-12 (plate 4) is a 13.8 kV aerial powerline which crosses over the levee at station 69+05. Approximately 170 linear feet of this facility will be affected by the project.

(vi) Item E-13. Item E-13 (plate 4) is a 35-foot power pole with attachments which is located adjacent to the landside levee toe at station 70+85 and which will be affected by the project.

(vii) Item E-14. Item E-14 (plate 4) consists of an overhead guy wire attached to a 45-foot pole located on the floodside of the levee at station 76+50 and of a guy pole and anchors located on the landside of the levee at station 80+00 which will be affected by the project.

(viii) Item E-19. Item E-19 (plate 5) consists of 3 guy poles with anchors located adjacent to the landside levee toe at stations 99+90, 101+80, and 104+90 which will be affected by the project.

(3) Other Facilities

(a) Algiers Iron Works and Drydock Company (Algiers Iron Works) Algiers Iron Works owns item E-8 (plate 3A), a buried electrical cable which crosses the levee at station 40+25. Approximately 100 linear feet of this facility will be affected by the project. Item E-8 is in good condition.

(b) Eastern Associates Terminals. Eastern Associates Terminals owns and operates the following facilities which will be affected by the project:

(i) Item P-1. Item P-1 (plate 2) is a small diameter pipeline which is located on the floodside of the levee between stations 23+80 to 27+00. Approximately 320 linear feet of this facility will be affected by the project. Item P-1 is in good condition.

(ii) Item G-1. Item G-1 (plate 3) is a 3-inch-diameter gasline which crosses the levee at station 26+90. Approximately 100 linear feet of this facility will be affected by the project. Item G-1 is in good condition.

(iii) Item W-3. Item W-3 (plate 3A) is a small diameter waterline which crosses the levee at station 30+05. Approximately 150 linear feet of this facility will be affected by the project. Item W-3 is in good condition.

(c) T. Smith and Sons, Inc. (Smith)

(i) Item W-9. Item W-9 (plate 4) is a small diameter waterline which crosses the levee at station 80+10. Approximately 100 linear feet of this facility will be affected by the project. Item W-9 is in good condition.

(ii) Item W-11. Item W-11 (plate 5) is a small diameter waterline which crosses the levee at station 96+90. Approximately 150 linear feet of this facility will be affected by the project. Item W-11 is in good condition.



(d) Unknown Owners.

(i) Item E-2. Item E-2 (plate 2) consists of three timber power poles located adjacent to the landside levee toe at stations 12+54, 14+14, and 15+65 which will be affected by the project.

Item E-2 is not in use.

(ii) Item E-5. Item E-5 (plate 2) consists of three timber power poles located on the floodside of the levee at stations 22+95, 24+13, and 25+13 which will be affected by the project. Item E-5 is not in use.

b. Setback Limits.

(1) Roads. The City of New Orleans, Department of Streets (Department of Streets) owns item R-1 (plate 3) the intersection of Seguin Street and Patterson Drive located between approximate levee stations 50+23 and 55+00. Each of the streets is a 20-foot wide, asphalt-paved, two-laned roadway. Approximately 250 linear feet of this facility will be affected by the project. Item R-1 is in fair condition.

(2) Utilities and Structures

(a) Sewerage and Water Board of New Orleans (S&WB). The S&WB owns the following facilities which are located within the setback limits of the project:

(i) Item W-5. Item W-5 is a 6-inch-diameter cast iron potable water line located under Seguin Street and Patterson Drive in the vicinity of station 52+52 (plate 3A). Approximately 420 linear feet of this facility (including one fire hydrant) will be affected by the project. This facility was installed in 1904 and has a design life of 100 to 150 years. It is assumed that item W-5 is in good condition.

(ii) Item S-1. Item S-1 (plate 4) is a 20-inch-diameter cast iron sewer outfall line which is located under the levee at approximate station 87+58 and which is supported on timber piles. Approximately 400 linear feet of this facility will be affected by the project. This facility was installed in 1909 and has a design life of 100 to 150 years. It is assumed to be in good condition.

(iii) Item S-2. Item S-2 (plate 4) is a 30-inch-diameter cast iron sewer outfall line which is located under the levee at approximate station 90+58 and which is supported on timber piles. Approximately 400 linear feet of this facility will be affected by the project. This facility was installed in 1930 and has a design life of 100 to 150 years. It is assumed to be in good condition.

(iv) Item S-3. Item S-3 (plate 3A) consists of an 8-inch-diameter sewer line and manhole located under Patterson Drive between stations 53+50 and 54+20. Approximately 180 linear feet of this

facility (including the manhole) will be affected by the project. Item S-3 was installed in the 1940's and has a design life of 100 to 150 years. Item S-3 is assumed to be in good condition.

(b) Board of Commissioners of the Port of New Orleans (Dock Board). The Dock Board owns the following facilities which are located within the setback limits of the project:

(i) Item WW-1. Item WW-1 (plate 3) is a three foot wide timber pedestrian walkway which services the fireboat dock located at station 51+75. Approximately 100 linear feet of this facility will be affected by the project. This facility was installed in 1971 and is in good condition.

(ii) Item W-6. Item W-6 (plate 3A) is a 6-inch-diameter waterline which crosses the levee at station 51+70 and services the fireboat dock located in the river. This facility was installed in 1977 and is in good condition. Approximately 200 linear feet of W-6 will be affected by the project.

(iii) Item W-7. Item W-7 (plate 3A) is a 4-inch-diameter waterline which crosses the levee at station 58+60, and services the Bermuda Street Wharf. Approximately 250 linear feet of this facility will be affected by the project. Item W-7 was installed in about 1940 and is in good condition.

(iv) Item G-4. Item G-4 (plate 3) is a two-inch-diameter gasline which crosses the levee at station 51+75. Approximately 250 linear feet of this facility will be affected by the project. Item G-4 is not in use at this time.

(c) South Central Bell Telephone Company (SCB). SCB owns the following facilities located within the setback limits which will be affected by the project:

(i) Item T-3. Item T-3 (plate 3) is an aerial and buried telephone cable which crosses the levee at about station 38+50 and services Algiers Iron Works and Drydock Company located on the floodside of the levee. Approximately 150 linear feet of this facility will be affected by the project. Item T-3 was installed in 1967 and has a design life of 35 years. This facility is in good condition.

(ii) item T-5. Item T-5 (plate 3) is an aerial telephone cable which crosses the levee at about station 52+20 and services the Dock Board's fireboat dock on the river. Approximately 400 linear feet of this facility will be affected by the project. Item T-5 was installed in 1976 and has a design life of 35 years. This facility is in good condition.

(iii) Item T-6. Item T-6 (plate 3) is a buried telephone cable which crosses the levee at station 58+10 and services the Bermuda Street Wharf on the river. Approximately 220 linear feet of this facility will be affected by the project. Item T-5 was installed in 1943 and has a design life of 38 years. This facility is not currently in use.

(iv) Item T-9. Item T-9 (plate 4) is an aerial telephone cable which crosses the levee at station 83+70 and services T. Smith and Sons, Inc., on the floodside of the levee. Approximately 170 linear feet of this facility will be affected by the project. Item T-9 was installed in 1946 and has a design life of 35 years. This facility is in good condition.

(v) Item T-10. Item T-10 (plate 5) is an aerial telephone cable which crosses the levee at station 95+90 and services T. Smith and Sons, Inc., on the floodside of the levee. Approximately 150 linear feet of this facility will be affected by the project. Item T-10 was installed in 1961 and has a design life of 35 years. This facility is in good condition.

(d) Louisiana Power and Light Company (LP&L). LP&L owns various facilities which are located within the setback limits and which will be affected by the project. The installation date of the LP&L facilities varies from 1962 to 1973 and design life is 30 years. The facilities are in good condition and are as follows:

(i) Item E-1. Item E-1 (plate 2) consists of two timber power poles located adjacent to the landside levee toe at stations 10+18 and 11+42 and will be dislocated by the project.

(ii) Item E-7. Item E-7 (plate 3A) is a 13.8 kV aerial powerline located between stations 38+10 and 45+40 which services Algiers Iron Works and two private dwellings located on the floodside of the levee. Approximately 170 linear feet of this facility will be affected within the setback limits (stations 38+10 to station 39+43).

(iii) Item E-10. Item E-10 (plate 3A) is an 13.8 kV aerial powerline located between stations 50+23 and 58+00. Approximately 720 linear feet of this facility will be affected by the project. This facility services the Dock Board's fireboat dock on the river.

(iv) Item E-11. Item E-11 (plate 4) is a 13.8 kV aerial powerline which crosses the levee at station 63+50 and services the Bermuda Street Wharf on the river. Approximately 250 linear feet of this facility will be affected by the project.

(v) Item E-15. Item E-15 (plate 4) is a 13.8 kV aerial powerline which crosses the levee at station 83+70 and services T. Smith and Sons, Inc., on the floodside of the levee. Approximately 380 linear feet of this facility will be affected by the project.

(vi) Item E-16. Item E-16 (plate 4) consists of an overhead guy wire attached to a 45 foot timber guy pole located at station 87+28 on the landside of the levee; it will be dislocated by the project.

(e) New Orleans Public Service, Inc. (NOPSI). NOPSI owns the following facilities which are located within the setback limits and which will be affected by the project:

(i) Item G-2. Item G-2 (plate 3) is a gas meter located at the landside levee toe opposite station 39+25. This facility is connected to item G-3 (plate 3), a two-inch-diameter gasline owned by Algiers Iron Works.

(ii) Item G-5. Item G-5 (plate 3) is a 2-inch-diameter gasline which crosses the levee at station 58+25 and services the Bermuda Street Wharf. Approximately 220 linear feet of this facility will be affected by the project.

(f) Algiers Iron Works and Drydock Company. Algiers Iron Works owns the following facilities which are located within the setback limits and which will be affected by the project:

(i) Item W-4. Item W-4 (plate 3A) is a small diameter waterline which crosses the levee at station 39+25. Approximately 100 linear feet of this facility will be affected by the project. Item W-4 is in good condition.

(ii) Item G-3. Item G-3 (plate 3) is a 2-inch-diameter gasline which crosses the levee at station 39+25. Approximately 100 linear feet of this facility will be affected by the project. This facility is not currently in use.

(iii) Item CR-1. Item CR-1 (plate 3) is a set of crane tracks (rails) located atop the levee at station 39+43, 80 feet of which will be affect by the project.

(g) T. Smith and Sons, Inc. Smith owns item W-10 (plate 4), a small diameter waterline which crosses the levee at 83+00 and services facilities located on the floodside of the levee. Approximately 100 linear feet of item W-10 will be affected by the project.

##### 5. OWNER'S COMPENSABLE INTEREST.

a. General. The attorney's report, which considers the compensable interest of the owners of the facilities affected by the project, is attached as Appendixes IA and IB.

(1) Roads. The attorney's report (Appendix IB) provides that the City of New Orleans has a compensable interest in its facility (item R-1) except any portion of item R-1 which is located within the existing levee right-of-way. Since all of item R-1 is located outside of the existing levee right-of-way, the Federal Government is authorized and obligated to pay for the relocation as required by the project.



b. Railroads. The attorney's report attached as Appendix IA states that "...Although the TP-MP (Missouri-Pacific Railroad Company) owns the underlying fee upon which the existing (levee) right-of-way is located, it does not have a compensable interest in its facility located within the existing levee right-of-way...." The entire affected segment of this facility is located within the existing levee right-of-way. Therefore the relocation cost of item R-2 is not a responsibility of the Federal Government.

c. Utilities and Structures.

(1) Sewerage and Water Borad of New Orleans. The attorney's report attached as Appendix IB finds that the S&WB is a public utility which is owned by the City of New Orleans. The attorney's report also states that the S&WB has a compensable interest in all of its facilities excepting any facility or portion of that facility which is located within the existing levee right-of-way. However, the attorney's report also states that where a public (governmental) utility will be destroyed or damaged due to the operation of a civil works project and relocation or alteration of the facility is required to continue service to the public, the Federal Government is authorized under Section 2 of the Flood Control Act of 1938 to assume the cost of relocating the facilities owned by the S&WB which will be affected by the project. Therefore, the cost of relocating items W-5, S-1, S-2, S-3, and E-9 will be borne by the Federal Government.

(2) Board of Commissioners of the Port of New Orleans. The attorney's report (Appendix IB) finds that the Dock Board, an agency of the State of Louisiana, has a compensable interest in all of its facilities that will be affected by the project. In accordance with the attorney's report, the relocations of items W-6, W-7, W-8, G-4 and WW-1 will be accomplished at federal expense.

(3) South Central Bell Telephone Company, Louisiana Power and Light Company, and New Orleans Public Service Inc. The attorney's report (Appendix IB) finds that, LP&L, and NOPSI are privately owned public utilities which have a compensable interest in their facilities affected by the project, excepting any facility or portion of that facility which is located within the existing levee right-of-way. In accordance with the attorney's report, the cost of relocating the facilities which are located outside of the existing levee right-of-way will be borne by the Federal Government. The relocations of the facilities located within the existing levee right-of-way will be accomplished at the individual owner's expense.

d. Other Facilities

(1) Eastern Associates Terminals, Algiers Iron Works, and T. Smith and Sons, Inc. The Attorney's report (Appendix IA) finds that Eastern Associates (items P-1, G-1, and W-3), Algiers Iron Works (items W-4, G-3, and RR-2), and Smith (items W-9 thru W-11) are not considered to be public utilities or common carriers, and they do not have a compensable interest in any of their facilities

which are located within the existing levee right-of-way. These facilities will be acquired by the project sponsor at no cost to the Federal Government.

6. FIELD RECONNAISSANCE AND INVESTIGATION. Field surveys, field inspections, consultations, and correspondence with the affected facility owners and the Orleans Levee District provided the basic information from which this design memorandum and the proposed relocations plans were prepared. This work was accomplished principally by Mr. R. Campos of this District's Relocations Section, Mr. E. Pilie of the Levees Section, and Mr. L. Gele' formerly of the Relocations Section.

7. CRITERIA FOR RELOCATED FACILITIES

a. Roads. The design criteria for the relocation of item R-1, the intersection of Seguin and Patterson Streets, will be in accordance with the provisions of the "General Specifications and Standard Plans for Street Paving and Temporary Surfacing of the City of New Orleans, Louisiana," adopted 28 November 1969. The design standards used for the proposed street relocation are the design standards used by the City of New Orleans Department of Streets and, therefore, do not result in a betterment. The street alteration will be designed by this District, and the construction will be performed by the levee contractor.

b. Railroad. No design criteria is required for item RR-1 since the railroad track is to be removed by the owner.

c. Utilities and Structures. The owners of public utilities (S&WB, NOPSI, LP&L, and SCB) will accomplish the design and relocation of their facilities to their individual criteria, and in a manner which will eliminate interference with the project. This District will review the construction drawings for the relocations to insure that no betterments are included at Federal expense. During construction and upon completion of construction, this District will inspect the relocations in the field to insure conformance with project requirements.

d. Other Facilities. The remaining facility owners (Associated Eastern Terminals, Algiers Iron Works, and T. Smith and Sons) will adjust or remove their facilities to their individual criteria and in a manner which will eliminate interference with the project. This District will inspect the relocations to insure conformance with project requirements. These facilities will be acquired by the project sponsor as part of the real estate acquisition program.

## 8. DESCRIPTION OF PROPOSED RELOCATIONS

a. Enlargement Limits.

(1) Railroads. Missouri-Pacific will remove approximately 46 linear feet of item RR-1 (plate 2) to allow construction of the levee. The track removal will be performed at the owner's expense.

(2) Utilities and Structures

(a) Sewerage and Water Board. The S&WB will relocate item E-9 (plate 3A) on the same alignment as that of the existing cables. The relocated facility will consist of approximately 300 linear feet of 6600 kV cable. This relocation is to be accomplished at Federal expense.

(b) Dock Board. The Dock Board will first cut and abandon item W-8 (plate 4), and the abandoned facility will be removed by the levee contractor. After the levee is completed, the Dock Board will construct the relocated item W-8. The relocated facility will consist of approximately 200 linear feet of 6 inch-diameter pipe, which will cross the completed levee at about station 50+20. This relocation is to be accomplished at Federal expense.

(c) South Central Bell

(i) Item T-1, (plate 2). Using existing slack in the cables, SCB will temporarily relocate the item T-1 to a new crossing approximately 20 feet downstream of the existing crossing. The levee contractor will build the levee at the site of the present

cable crossing. SCB will then relocate item T-1 to its original alignment over the levee. All of the work in relocating item T-1 will be performed at SCB's expense.

(ii) Item T-2, (plate 3). SCB will relocate item T-2 in a manner that will not interfere with the project. The new facility will consist of approximately 150 linear feet of aerial cable, and the relocation will be performed at SCB expense.

(iii) Item T-4, (plate 3). SCB will relocate item T-4 to a new crossing adjacent to the relocated S&WB item E-9. Item T-4 will be relocated at the owner's expense.

(iv) Item T-7, (plate 4). A temporary "no work area" will be designated at the location of the existing item T-7. The levee contractor will build the levee both upstream and downstream of the item T-7 levee crossing. The owner will then temporarily place the cable over the completed levee, and the contractor will then complete the levee within the previously designated "no work area". SCB will then relocate item T-7 to its original location at station 72+85. This relocation will be performed at the owner's expense.

(d) Louisiana Power and Light

(i) Item E-3, (plate 2). LP&L will relocate item E-3, a 45-foot long timber power pole with attachments to a location outside of the existing levee right-of-way. The cost of this relocation will be borne by the owner.

(ii) Item E-4, (plate 2). LP&L will adjust item E-4 by removing the overhead guy wire over the levee and by supporting the landside power pole with a push brace. The light standard will also be removed. The Federal Government will pay for the adjustment of the portion of item E-4 which is outside of the existing levee right-of-way. The remainder of this facility will be relocated at the owner's expense.

(iii) Item E-6, (plate 3A). LP&L will relocate item E-6 a 40-foot timber pole with attachments to a location outside of the levee right-of-way. This facility will be relocated at the owner's expense.

(iv) Item E-7, (plate 3A). LP&L will adjust item E-7 in a manner that will not interfere with the project. Adjustments will consist of removing the portions of item E-7 which are located on the floodside of the levee (at the owner's expense) and relocating the landside facilities outside of the levee right-of-way (at Federal expense).

(v) Item E-12, (plate 4). LP&L will adjust item E-12 by relocating the guy pole on the floodside of the levee riverward of its existing location. This relocation will be performed at the owner's expense.

(vi) Item E-13, (plate 4). LP&L will remove item E-13, a 35-foot power pole with attachments. This work is to be performed at LP&L's expense.

(vii) Item E-14, (plate 4). LP&L will relocate the guy pole at station 76+50 approximately 8 feet riverward and the guy pole at station 80+00 approximately 15 feet landward to avoid interference with the project. The cost of relocating the riverside pole will be borne by LP&L while the landside pole will be relocated at Federal expense.

(viii) Item E-19, (plate 5). LP&L will relocate the three guy poles and anchors landward to avoid interference with the project. This work will be performed at Federal expense.

(3) Other Facilities



(a) Algiers Iron Works. Algiers Iron Works will cut and abandon their existing buried power cable (item E-8, plate 3A), and the abandoned cable will be removed by the levee contractor. Algiers Iron Works will replace the buried cable with an aerial cable over the completed levee. The cost of relocating item E-8 will be borne by the owner.

(b) Eastern Associates

(i) Items P-1 and G-1, (plates 2 and 3, respectively).

Eastern Associates will remove items P-1 (pipeline) and G-1 (gasline) prior to the start of levee construction. This work will be performed at no cost to the Federal Government.

(ii) Item W-3, (plate 3A). Eastern Associates will relocate item W-3 over the completed levee. The new facility will occupy basically the same location as the existing facility. This work will be performed at no expense to the Federal Government.

(c) T. Smith and Sons. T. Smith and Sons will relocate items W-9 and W-11 (plates 4 and 5, respectively) over the completed levee at no expense to the Federal Government. The new waterlines will occupy essentially the same location as the existing facilities.

(d) Unknown Owners. The Board of Commissioners of the Orleans Levee District will grant to this District releases to allow the Government's contractor to remove items E-2 and E-5 (plate 2).

b. Setback Limits

(1) Roads. The existing item R-1 (intersection of Patterson Drive and Seguin Street) will be abandoned by the City of New Orleans, Department of Streets. The Government's contractor will remove the existing road surface and reconstruct the streets intersection at the location and according to the details shown on plate 9 of inclosure 1. Item R-1 will be relocated at the expense of the Federal Government.

(2) Utilities and Structures

(a) Sewerage and Water Board of New Orleans

(i) Item W-5, (plate 3A). The S&WB will cut and abandon the affected segment of the existing 6-inch-diameter water main. Item W-5 will be relocated to an alinement directly beneath the new location of item R-1, Patterson Drive and Seguin Street. This work will be performed by the S&WB at the expense of the Federal Government.

(ii) Item S-1 and item S-2, (plate 4). The S&WB will first construct a 20-inch-diameter bypass line between the existing 20-inch-diameter sewer main (item S-1) and the 30-inch-diameter sewer main (item S-2). The bypass line will occupy the existing Patterson Drive right-of-way. The S&WB will then cut and abandon the existing portion of item S-2 which will be affected by the levee setback.

The Government's contractor will excavate and remove the abandoned item S-2 and then will build the levee setback to full grade and section. After completion of this segment of levee, the S&WB will permanently construct a new 30-inch-diameter sewer main over the levee. The same procedure will be repeated for abandoning removing, and constructing the 20-inch-diameter sewer main (item S-1). Costs associated with adjusting item S-1 and S-2 will be borne by the Federal Government. Additional details and orders of work for the setback reach which contains items S-1 and S-2 are shown on plate 10 of this report.

(iii) Item S-3, (plate 3A). The S&WB will cut item S-3 and abandon the approximately 140 linear feet of pipe and the manhole which will be affected by the project. The abandoned facility will be removed by the Government's contractor. The S&WB will construct a new manhole at the new terminus of item S-3. Item S-3 will be adjusted at Federal Government expense.

(b) Dock Board

(i) Item WW-1, (plate 3) and Item W-6 (plate 3A). The Dock Board will abandon item WW-1 (pedestrian walkway) and item W-6 (waterline), and these facilities will be removed by the Government's contractor. Replacement of these facilities will not be required since the Dock Board plans to permanently relocate their fire boats to the Bermuda Street Wharf, vicinity station 58+60 (plate 3A).

(ii) Items W-7 (plate 3A) and W-8 (Plate 4). The Dock Board will construct approximately 200 linear feet of 4-inch-diameter and 6-inch-diameter waterline to service the Bermuda Street Wharf. Temporary service will be provided to the wharf by flexible hoses which can be routed around the work areas. The permanent facility will be constructed after completion of the levee setback. Items W-7 and W-8 are to be relocated at Federal expense.

(iii) Item G-4, (plate 3). The Dock Board will abandon item G-4 (gasline), and it will be removed by the Government's contractor.

(c) South Central Bell Telephone Company

(i) Item T-3, (plate 3), Item T-6, (plate 3), Item T-9 (plate 4), and Item T-10, (plate 5). These aerial and buried telephone cables will be relocated by SCB in a manner that will not interfere

with the levee work. These facilities are located within the existing levee right-of-way, therefore the relocations will be performed at the owner's expense.

(ii) Item T-5, (plate 3). The telephone cable which services the Dock Board's existing fire boat landing will be removed by SCB. This removal will be performed at the owner's expense.

(d) Louisiana Power and Light Company

(i) Item E-1, (plate 2). L&PL will relocate the existing poles to locations outside of the required levee right-of-way. This relocation will be performed at a LP&L's expense.

(ii) Item E-7, (plate 3A), Item E-11, (plate 4), Item E-15 (plate 4), and Item E-16, (plate 4). The interfering aerial power-lines and aerial guy wires will be relocated by LP&L in a manner that will not interfere with the project. The portions of these facilities which are located outside of the existing levee right-of-way will be relocated at Federal expense. The cost of relocating the facility segments located within the existing levee right-of-way will be borne by the owner.

(iii) Item E-10, (plate 3A). LP&L will remove the 13.8 kV powerline which services the existing fire boat landing. The cost of removing item E-10 will be split between the Federal Government and the owner.

(e) New Orleans Public Service, Inc.

(i) Item G-2, (plate 3). NOPSI will remove the gas meter which is attached to the Algiers Iron Works owned gasline. Removal of this facility will be at the owner's expense.

(ii) Item G-5, (plate 3). NOPSI will cut and abandon the existing gasline which crosses the levee at the Bermuda Street Wharf. The Dock Board will not request restoration of service. The abandoned gasline will be removed by the Government's contractor.

(f) Algiers Iron Works

(i) Item W-4, (plate 3A). Algiers Iron Works will relocate their waterline in a manner that will not interfere with the project. This facility will be relocated at the owner's expense.

(ii) Item G-3, (plate 3). The existing gasline will be cut and abandoned by the owner at no cost to the Federal Government. The abandoned facility will be removed by the Government's contractor.

(iii) Item CR-1, (plate 3). The interfering 80 feet of crane rails will be removed by the owner at no expense to the Federal Government.

(g) T. Smith and Sons, Inc. Smith will relocate their existing waterline (item W-10, plate 4) in a manner that will eliminate interference with the project. This relocation will be performed at the owner's expense.

#### 9. PROCEDURE FOR ACCOMPLISHING RELOCATIONS

a. Roads. The City of New Orleans, Department of Streets furnished the criteria and basic design for item R-1, the intersection of Patterson Drive and Seguin Streets. This District will prepare the detailed plans and specifications for the relocated roadway, which will be constructed by the Government's contractor at no cost to the owner. The right-of-way required for the new roadway is shown on plate 3.

b. Railroads. The Board of Commissioners of the Orleans Levee District will notify Missouri-Pacific that removal of 46 linear feet of their track (item R-2, plate 2) is required, and that the removal is to be performed at the owner's expense.

c. Utilities

(1) The affected utility owners will prepare detailed plans and specifications for the cutting, abandoning, removing, or relocating of their facilities, and they will accomplish their work in a manner that will not interfere with the project. The owners' plans and specifications will be reviewed by this District to determine if the owners' proposals are compatible with the project. The relocations will be closely coordinated among all parties involved. The Board of Commissioners of the Orleans Levee District, as the local assuring agency for the work, will advise the affected owners to effect their relocations. If the owner's work is to be performed at Federal expense, this district will advise the Levee Board of the dollar amount (based on the approved design memorandum) available for reimbursement to the owner. Payments will be based on actual cost for accomplishing the work, adjusted where appropriate, for depreciation, salvage value, and betterments. Upon completion of the relocation, the Orleans Levee District will furnish a reimbursement assembly to this District consisting of: copies of any contracts (including plans and specifications) covering work performed by others or itemized billings for labor and materials if the work was performed by the owner, and a copy of all canceled checks covering related payments. Further, all records related to the reimbursement request will be subject to audit by the Government and original time cards or payrolls, material records, and accounts for all charges and



expenditures for which reimbursement will be claimed from the Government will be available at all reasonable times for Government inspection. Finally, so far as practicable, the owner will maintain separate records for all items and accounts constituting the basis of information from which the reimbursement assembly is prepared.

(2) Unknown Owners. The Orleans Levee Board will declare as abandoned the interfering facilities whose owners are unknown. The Levee Board will also grant this District written releases to allow the Government's contractor to remove the affected facilities (items E-2 and E-5 on plate 2).

#### 10. ATTITUDE OF OWNERS

a. The Dock Board, S&WB, Department of Streets, SCB, LP&L, and NOPSI all concur in the relocation plans and in the determination of compensable interest presented in this design memorandum. Information requested from the owners, however, has been slow in coming, especially from the S&WB and from the Dock Board. Both of these agencies hesitated to develop relocation plans and cost estimates, which required their expending significant engineering effort on this project, prior to their receiving written assurances that their expenses would be reimbursable by the Federal Government. It is expected that once these agencies have been advised that their relocation costs are indeed reimbursable (after approval of this

design memorandum), the timeliness of their responses to this Districts requests for information will improve significantly. All of the above owners are now actively pursuing the work required to relocate their facilities upon notification by the Board of Commissioners of the Orleans Levee District.

b. Eastern Associated Terminals, Algiers Iron Works, and T. Smith and Sons have cooperated in developing the relocation plans contained herein. These owners disagree with this District's determination that their relocation costs are not reimbursable by the Federal Government but the Orleans Levee Board has mitigated these disagreements by settling with some of the owners for at least part of their relocation cost. The Federal Government will not reimburse the Levee Board for the Levee Board's payments to these owners.

c. Initial planning for this project indicated that 310 linear feet of Missouri-Pacific existing 763 foot long switching track required removal. Missouri-Pacific claimed that removal of 310 feet of track would render their facility useless for their operations. They would have to remove the entire length of track and construct new switching facilities adjacent to their existing main line tracks, at a cost of approximately \$18,000. The Railroad objected to performing this work at their expense. This District reconsidered the

project's impact on the railroad track and reduced that impact to only the last 46 feet of track. The Orleans Levee Board has notified MOPAC in writing of the Railroad's need to remove the last 46 feet of their track. We expect MOPAC to still claim reimbursement for their work, but we do not expect any further difficulties with the owner.

d. The Board of Commissioners of the Orleans Levee District has actively participated in assisting this District in planning the Algiers Point project. Many of the problems or differences that were first advanced by the affected owners have now been successfully mitigated by the Levee Board, and the Board is continuing its efforts toward the consumation of this project.

11. FACILITIES NOT AFFECTED. The following facilities will not be affected by the project:

<u>Item No.</u>	<u>Facility</u>	<u>Owner</u>	<u>Location</u>	
W-1	30" Water Intake	S&WB	Sta. 3+45	(plate 2)
W-2	20" Water Intake	S&WB	11+25	(plate 2)
T-8	Telephone Line & Poles	SCB	73+00-77+00	(plate 4)
E-17	Aerial Powerline	LP&L	96+10	(plate 5)
E-18	Guy Poles and Anchors	LP&L	98+70; 105+80	(plate 5)

12. ESTIMATE OF COST. The estimated Federal cost for accomplishing the proposed relocations has been prepared in accordance with the provisions of ER-1180-1-1 and is based on relocation plans proposed.

by or agreed to by the affected owners. The relocation costs are summarized in Table 2 below, and they are presented in more detail in tables 4 through 8 (Appendix II) of this report.

TABLE 2

SUMMARY OF ESTIMATED FEDERAL RELOCATIONS COST

(JULY 1979 PRICE LEVELS)

<u>DESCRIPTION/OWNER</u>	<u>CONST.</u> <u>FUNDS (\$)</u>	<u>MAINT.</u> <u>FUNDS (\$)</u>	<u>TOTAL</u> <u>COSTS (\$)</u>
Roads	0	86,000	86,000
City of New Orleans			
Seguin St. & Patterson Dr.	(0)	(30,000)	(30,000)
Road R/W	(0)	(56,000)	(56,000)
Utilities	46,000	496,000	542,000
S&WB	(38,000)	(445,000)	(483,000)
Dock Board	(0)	(43,000)	(43,000)
LP&L	<u>(8,000)</u>	<u>(8,000)</u>	<u>(16,000)</u>
Subtotal Relocations	46,000	582,000	628,000 <sup>1</sup>
E & D (6%+)	3,000	33,000	36,000 <sup>2</sup>
S & A (6%+)	<u>3,000</u>	<u>33,000</u>	<u>36,000<sup>2</sup></u>
TOTAL	52,000	648,000	700,000

<sup>1</sup>Includes contingencies

<sup>2</sup>No E & D or S & A for Road R/W

13. COMPARISON WITH PRIOR COST ESTIMATES. The current working cost estimates for the relocations required by the Algiers Point project are summarized below for comparison with the latest approved cost estimates. The latest approved cost estimates have been separated from the respective documents for the Mississippi River Levees project for suitable comparison.

a. Construction Funds. The latest approved cost estimate for construction funds is the Project Cost Estimate (PB-3), effective 1 October 1979, which was approved 18 June 1979.

TABLE 3A

COMPARISON OF COST - CONSTRUCTION FUNDS

<u>Item</u>	<u>Latest</u> <u>PB-3</u> <u>(\$1,000's)</u>	<u>Current</u> <u>Working Estimate</u> <u>(\$1,000's)</u>	<u>Difference</u> <u>from PB-3</u> <u>(\$1,000's)</u>
Relocations			
Roads	0	0	0
Railroads	61.0	0	-61.0
Utilities	2,543.0	46.0	-2,497.0
E & D	3.0	3.0	0
S & A	3.0	3.0	0
TOTAL	2,610.0	52.0	-2,558.0

b. Maintenance Funds. The latest approved cost estimate for maintenance funds is the Detailed Project Schedule (PB-2A), CYR ES 013, effective 1. October 1978.

TABLE 3B

COMPARISON OF COST - MAINTENANCE FUNDS

<u>Item</u>	<u>Latest</u>	<u>Current</u>	<u>Difference</u>
	<u>PB-2A</u>	<u>Working Estimate</u>	<u>from PB-2A</u>
	<u>(\$1,000's)</u>	<u>(\$1,000's)</u>	<u>(\$1,000's)</u>
Relocations			
Roads	168.2	86.0	-82.2
Railroads	0	0	0
Utilities	220.8	496.0	+275.2
E & D	33.0	33.0	0
S & A	33.0	33.0	0
TOTAL	455.0	648.0	+193.0

TABLE 3C

COMPARISON OF COST

CONSTRUCTION AND MAINTENANCE FUNDS

<u>Item</u>	<u>Latest Approved Cost</u>	<u>Current</u>	<u>Difference from</u>
	<u>(\$1,000's)</u>	<u>Working Estimate</u>	<u>Approved Cost</u>
	<u>(\$1,000's)</u>	<u>(\$1,000's)</u>	<u>(\$1,000's)</u>
Relocations			
Roads	168.2	86.0	-82.2
Railroads	61.0	0	-61.0
Utilities	2,763.8	542.0	-2221.8

E & D (6%+)	36.0	36.0	0
S & A (6%+)	<u>36.0</u>	<u>36.0</u>	<u>0</u>
TOTAL	3,065.0	700.0	-2365.0

14. JUSTIFICATION FOR COST REVISION. When the Algiers Point project was proposed, substantial landside enlargement reaches were anticipated. Such preliminary planning envisioned the project affecting, in addition to the relocations described herein, the 30-inch and 20-inch-diameter raw water intakes (items W-1 and W-2, plate 2), the Canal Street Ferry landing and its appurtenant structures (plate 3), and portions of Patterson Drive (plate 4) and its associated utilities, such as sewer, water, and gas mains, major electrical and telephone distribution lines, and adjacent buildings. After initial planning, much effort was devoted to detailed engineering analysis and to consultations with all parties involved to mitigate the magnitude of required relocations while still maintaining the integrity of the project. Previously anticipated major relocations (items W-1 and W-2 and Patterson Drive, etc.) were "saved", accounting for the bulk of the estimated relocation costs adjustments. The ferry landing (within levee enlargement reach) is currently designated as a "no work area". Any levee work required in this area will be performed after the Mississippi River Bridge Authority (MRBA), operator of the ferry facilities, completes its modifications (now under construction) to the landing. The MRBA's work has been closely coordinated with this District. That coordination resulted in the MRBA designing features into its project which will further

reduce relocations at the ferry landing. Additionally, some of the owners who were thought to have a compensable interest in their facilities (e.g. MOPAC, SCB, and others) were found to be not eligible for Federal compensation for relocating or removing their facilities. All of these developments, when combined with price level escalations over a number of years, account for the substantial decrease in the overall estimated Federal relocation cost.

15. RECOMMENDATIONS. We recommend that this design memorandum be approved as the basis for reimbursing the Board of Commissioners of the Orleans Levee District for accomplishing the relocations as described in this report.



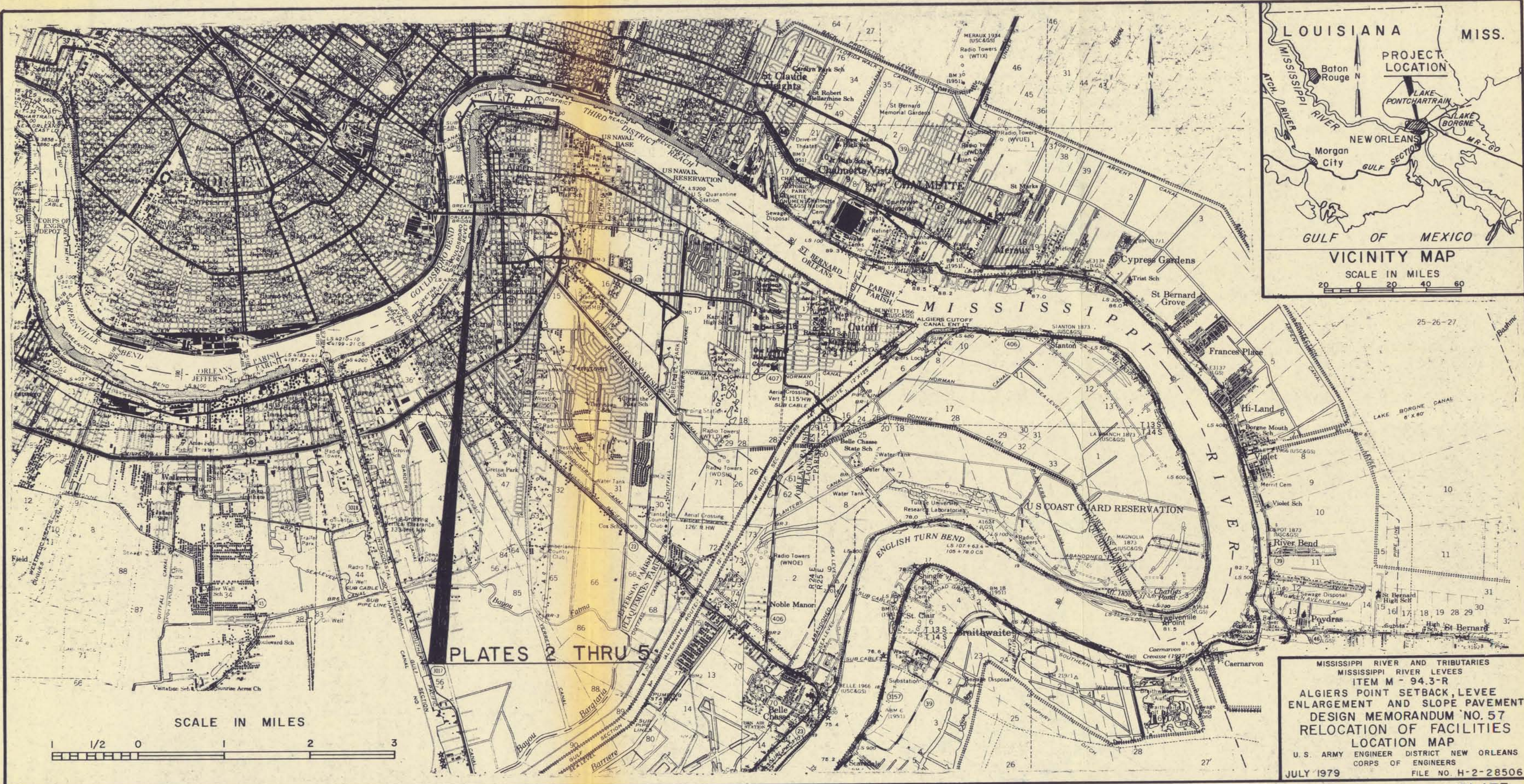

SCALE IN MILES

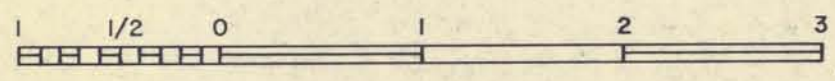

PLATES 2 THRU 5

MISSISSIPPI RIVER AND TRIBUTARIES  
MISSISSIPPI RIVER LEVEES  
ITEM M - 94.3-R  
ALGIERS POINT SETBACK, LEVEE  
ENLARGEMENT AND SLOPE PAVEMENT  
DESIGN MEMORANDUM NO. 57  
RELOCATION OF FACILITIES  
LOCATION MAP  
U. S. ARMY ENGINEER DISTRICT NEW ORLEANS  
CORPS OF ENGINEERS  
JULY 1979 FILE NO. H-2-28506

# MISSISSIPPI RIVER

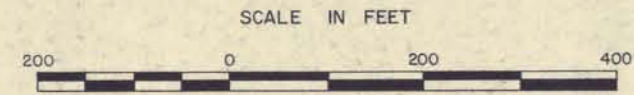
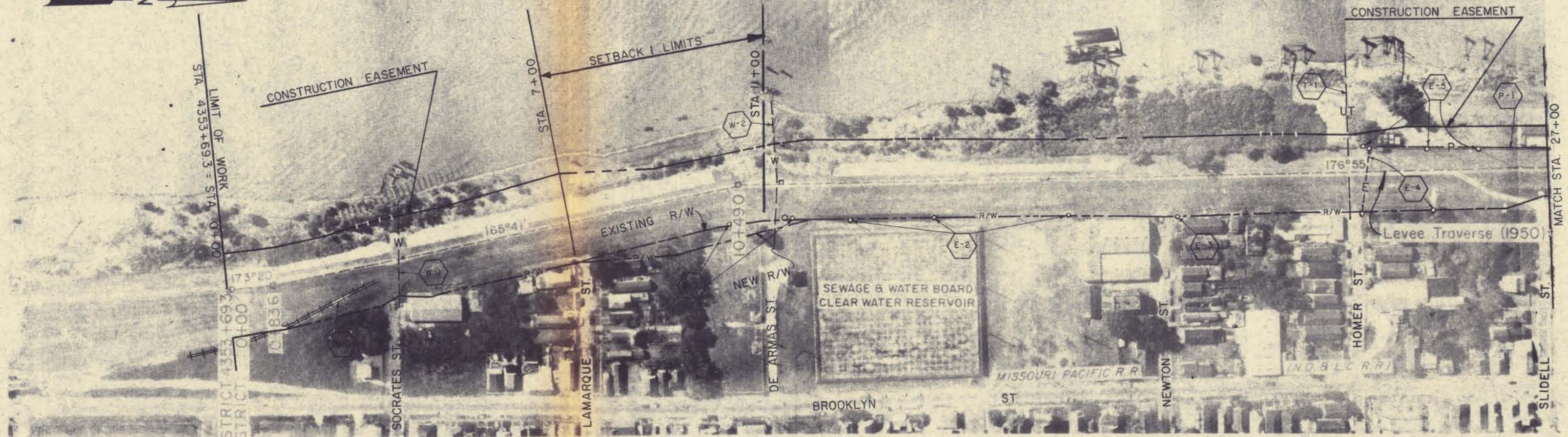
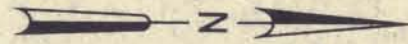

LAFORCHE BASIN LEVEE DISTRICT 4353+69.3  
ORLEANS LEVEE DISTRICT 0+00  
WEST BK

### EXISTING FACILITIES

ITEM NO	DESCRIPTION	B/L STATION	OWNER	DISPOSITION
RR-1	RAILROAD TRACK	2+50 TO 3+00	MISSOURI-PACIFIC	REMOVE
W-1	30" WATER INTAKE	3+45	SEWERAGE & WATER BOARD OF N.O.	NOT AFFECTED
W-2	20" WATER INTAKE	11+25	" " " "	NOT AFFECTED
E-1	2" POWER POLES	10+18 & 11+42	LA. POWER & LIGHT COMPANY	REMOVE
E-2	3" POWER POLES	12+54, 14+14 & 15+65	UNKNOWN	REMOVE
E-3	1" POWER POLE	19+15	LA. POWER & LIGHT COMPANY	RELOCATE
E-4	AERIAL POWERLINE	22+96 & 24+28	" " " "	REMOVE
E-5	3" POWER POLES	22+95, 24+13 & 25+13	UNKNOWN	REMOVE
T-1	6-BURIED TELEPHONE CABLES	22+85	SOUTH CENTRAL BELL	RELOCATE
P-1	PIPELINE	23+80 TO 27+00	EASTERN ASSOCIATES	REMOVE

**NOTE:**  
 POLYCONIC PROJECTION-1927 NORTH AMERICAN DATUM.  
 CONTROLLED MOSAIC PREPARED FROM AERIAL PHOTOS  
 FLOWN NOV.-DEC. 1967.

MISSISSIPPI RIVER AND TRIBUTARIES  
 MISSISSIPPI RIVER LEVEES  
 ITEM M-94.3-R  
 ALGIERS POINT SETBACK, LEVEE  
 ENLARGEMENT, AND SLOPE PAVEMENT  
**DESIGN MEMORANDUM NO.57**  
**RELOCATION OF FACILITIES**  
 PROJECT PLAN  
 U.S. ARMY ENGINEER DISTRICT NEW ORLEANS  
 CORPS OF ENGINEERS  
 JULY 1979 FILE NO. H-2-28506

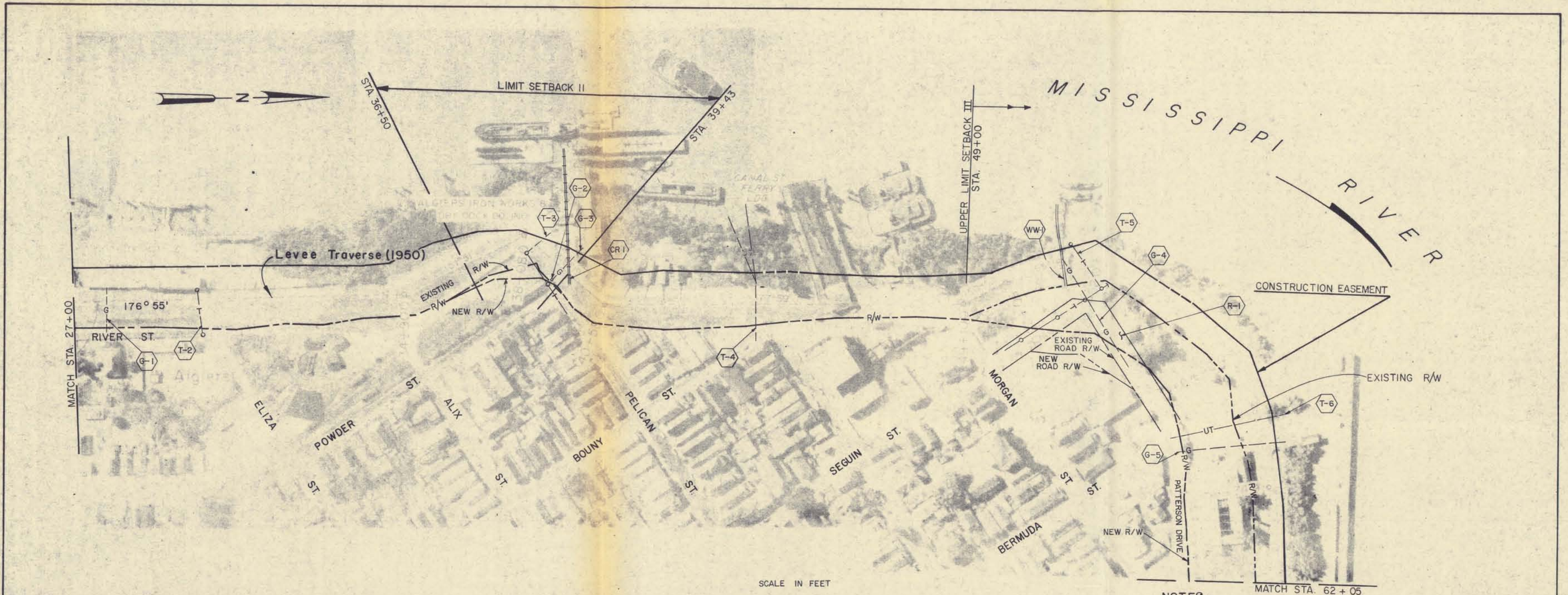

EXISTING FACILITIES

ITEM NO.	DESCRIPTION	B/L STATION	OWNER	DISPOSITION
WW-1	TIMBER WALKWAY	51 + 75	BOARD OF COMMISSIONERS OF THE PORT OF N.O.	ABANDON
G-1	GASLINE	26 + 90	EASTERN ASSOCIATES	REMOVE
G-2	GASMETER	39 + 25	NOPSI	REMOVE
G-3	GASLINE	39 + 25	ALGIERS IRON WORKS	ABANDON
G-4	GASLINE	51 + 75	BOARD OF COMMISSIONERS OF THE PORT OF N.O.	ABANDON
G-5	GASLINE	58 + 25	NOPSI	REMOVE
T-2	TELEPHONE LINE	30 + 00	SOUTH CENTRAL BELL	RELOCATE
T-3	TELEPHONE LINE	38 + 10 TO 39 + 43	II	RELOCATE
T-4	4-UNDERGROUND CABLES & RELAY BOXES	44 + 30	II	RELOCATE
T-5	CABLE & POLES	50 + 23 TO 52 + 53	II	RELOCATE
T-6	UNDERGROUND CABLE	58 + 10	I	REMOVE
CR-1	CRANE TRACKS	39 + 43	ALGIERS IRON WORKS	REMOVE
R-1	SEGUIN ST. AND PATTERSON DRIVE	50 + 23 TO 55 + 00	CITY OF NEW ORLEANS	RELOCATE

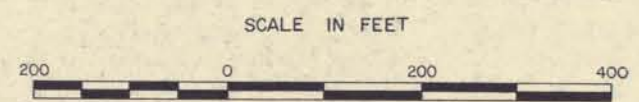

NOTES:  
 POLYCONIC PROJECTION-1927 NORTH AMERICAN DATUM.  
 CONTROLLED MOSAIC PREPARED FROM AERIAL PHOTOS  
 FLOWN NOV.-DEC. 1967.  
 FOR WATERLINES & POWERLINES SEE PLATE 3A.

MISSISSIPPI RIVER AND TRIBUTARIES  
 MISSISSIPPI RIVER LEVEES  
 ITEM M-94.3-R  
 ALGIERS POINT SETBACK, LEVEE  
 ENLARGEMENT, AND SLOPE PAVEMENT  
**DESIGN MEMORANDUM NO.57**  
**RELOCATION OF FACILITIES**  
**PROJECT PLAN**  
 U.S. ARMY ENGINEER DISTRICT NEW ORLEANS  
 CORPS OF ENGINEERS  
 JULY 1979 FILE NO. H-2-28506

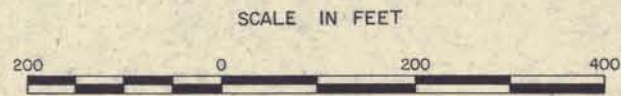
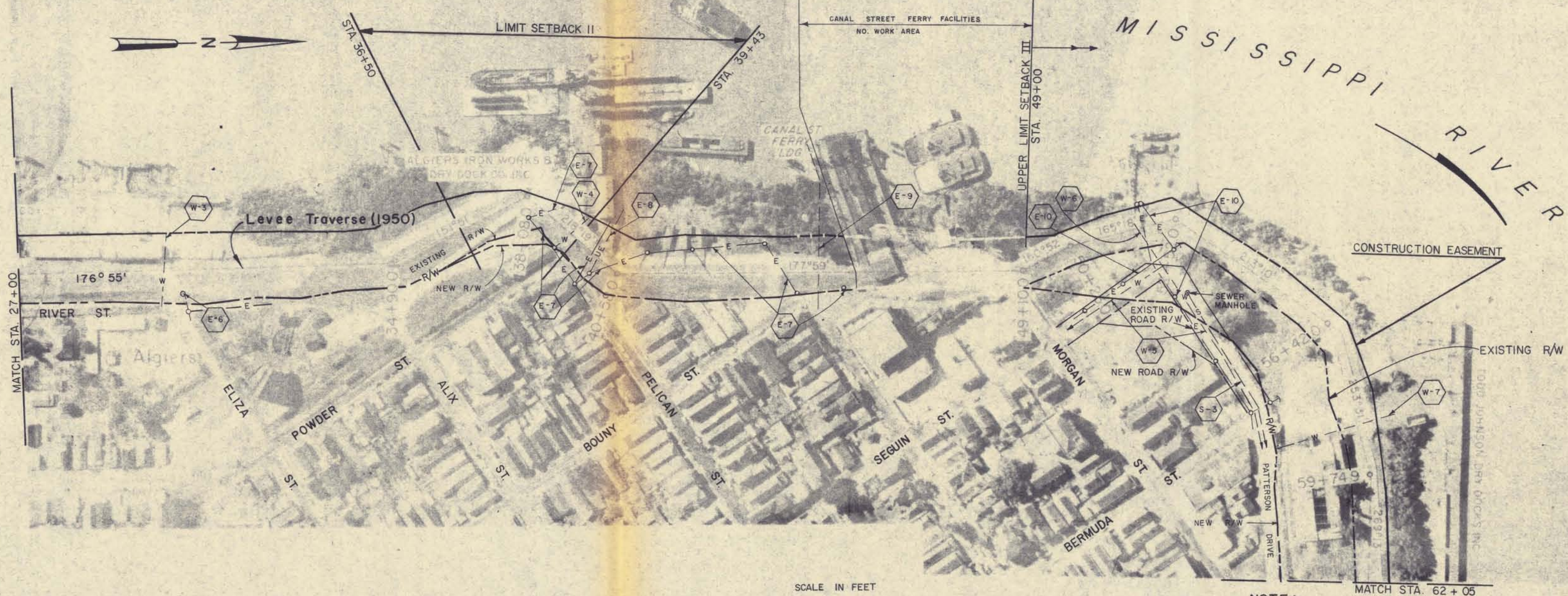

NOTE:  
 POLYCONIC PROJECTION-1927 NORTH AMERICAN DATUM.  
 CONTROLLED MOSAIC PREPARED FROM AERIAL PHOTOS  
 FLOWN NOV.-DEC. 1967.

EXISTING FACILITIES

ITEM NO	DESCRIPTION	B/L STATION	OWNER	DISPOSITION
W-3	WATERLINE	30+05	EASTERN ASSOCIATES	RELOCATE
W-4	WATERLINE	39+25	ALGIERS IRON WORKS	RELOCATE
W-5	6" WATERLINE	50+80 TO 54+20	SEWERAGE & WATER BOARD OF N. O.	RELOCATE
W-6	WATERLINE	51+70	BOARD OF COMMISSIONERS OF THE PORT OF N. O.	ABANDON
W-7	WATERLINE	58+60	" " " "	RELOCATE
E-6	POWERLINES & POLES	30+10	LA. POWER & LIGHT COMPANY	RELOCATE
E-7	POWERLINES & POLES	38+10 TO 45+40	" " " "	RELOCATE
E-8	UNDERGROUND POWER	40+25	ALGIERS IRON WORKS	RELOCATE
E-9	2 UNDERGROUND CABLES & SWITCH BOX	44+90	SEWERAGE & WATER BOARD OF N. O.	RELOCATE
E-10	POWERLINES & POLES	50+23 TO 58+00	LA. POWER & LIGHT COMPANY	RELOCATE
S-3	SEWERLINE	53+50 TO 54+20	SEWERAGE & WATER BOARD OF N. O.	RELOCATE

MISSISSIPPI RIVER AND TRIBUTARIES  
 MISSISSIPPI RIVER LEVEES  
 ITEM M-94.3-R  
 ALGIERS POINT SETBACK, LEVEE  
 ENLARGEMENT, AND SLOPE PAVEMENT  
**DESIGN MEMORANDUM NO.57**  
**RELOCATION OF FACILITIES**  
 PROJECT PLAN  
 U. S. ARMY ENGINEER DISTRICT NEW ORLEANS  
 CORPS OF ENGINEERS  
 JULY 1979 FILE NO. H-2-28506

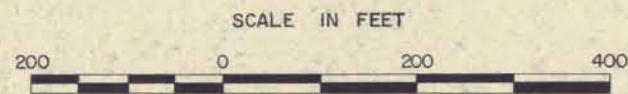
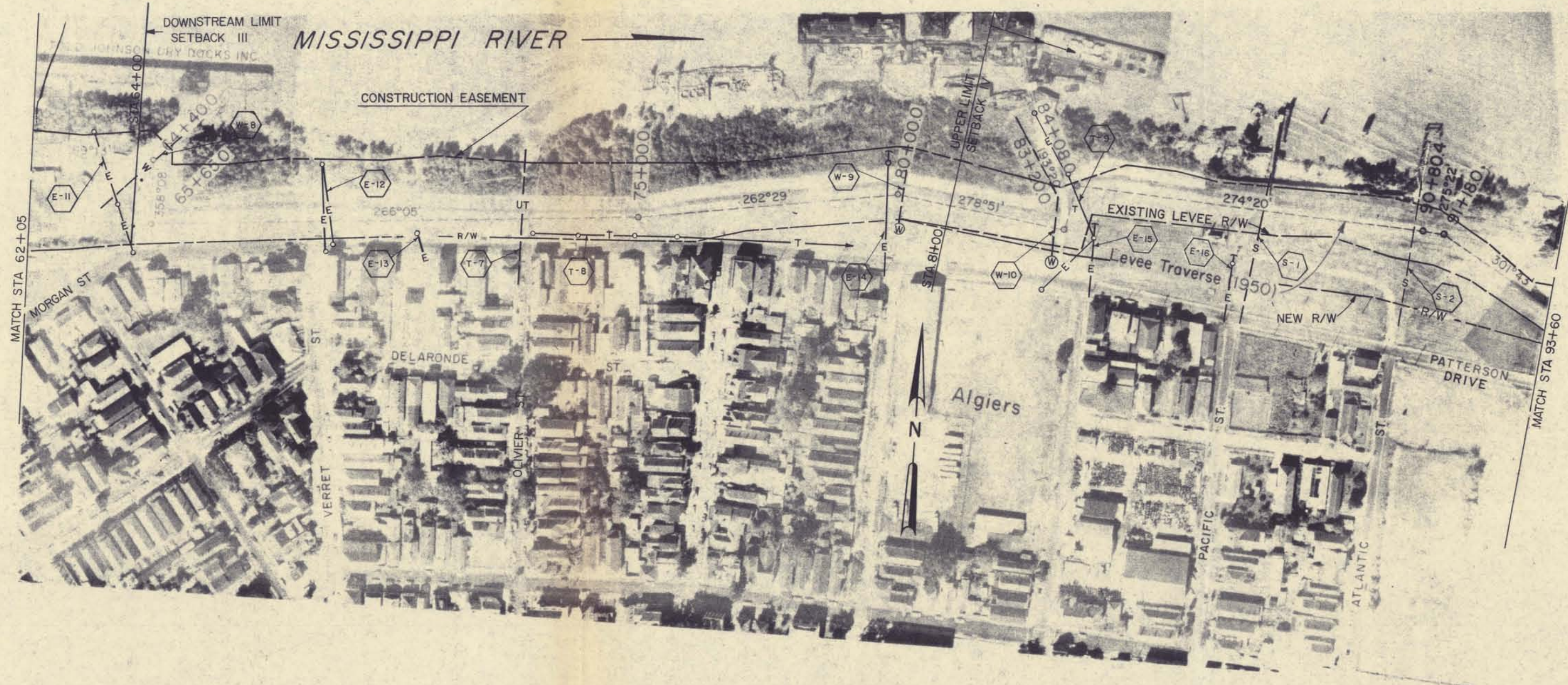

NOTE:  
 POLYCONIC PROJECTION-1927 NORTH AMERICAN DATUM.  
 CONTROLLED MOSAIC PREPARED FROM AERIAL PHOTOS  
 FLOWN NOV.-DEC. 1967.

EXISTING FACILITIES

ITEM NO	DESCRIPTION	B/L STATION	OWNER	DISPOSITION
W-8	WATERLINE	64+40	BOARD OF COMMISSIONERS OF THE PORT OF N.O.	RELOCATE
W-9	WATERLINE	80+10	T. SMITH & SONS	RELOCATE
W-10	WATERLINE	83+00	" " " "	RELOCATE
S-1	20" SEWER OUTFALL	87+58	SEWERAGE & WATER BOARD OF N.O.	RELOCATE
S-2	30" SEWER OUTFALL	90+58	" " " "	RELOCATE
T-7	BURIED TELEPHONE CABLE	72+85	SOUTH CENTRAL BELL	RELOCATE
T-8	TELEPHONE LINE & POLES	73+00 TO 77+00	" " " "	NOT AFFECTED
T-9	TELEPHONE LINE	83+70	" " " "	RELOCATE
E-11	POWERLINES & POLES	63+50	LA. POWER & LIGHT COMPANY	REMOVE
E-12	" " " "	69+05	" " " "	RELOCATE
E-13	" " " "	70+85	" " " "	RELOCATE
E-14	" " " "	80+00	" " " "	RELOCATE

EXISTING FACILITIES

ITEM NO	DESCRIPTION	B/L STATION	OWNER	DISPOSITION
E-15	POWERLINES & POLES	83+70	LA. POWER & LIGHT COMPANY	RELOCATE
E-16	GUY POLE & ATTACHMENTS	87+28	" " " "	RELOCATE

MISSISSIPPI RIVER AND TRIBUTARIES  
 MISSISSIPPI RIVER LEVEES  
 ITEM M-94.3-R  
 ALGIERS POINT SETBACK, LEVEE  
 ENLARGEMENT, AND SLOPE PAVEMENT  
**DESIGN MEMORANDUM NO.57**  
**RELOCATION OF FACILITIES**  
**PROJECT PLAN**  
 U. S. ARMY ENGINEER DISTRICT NEW ORLEANS  
 CORPS OF ENGINEERS  
 JULY 1979 FILE NO. H-2-28506

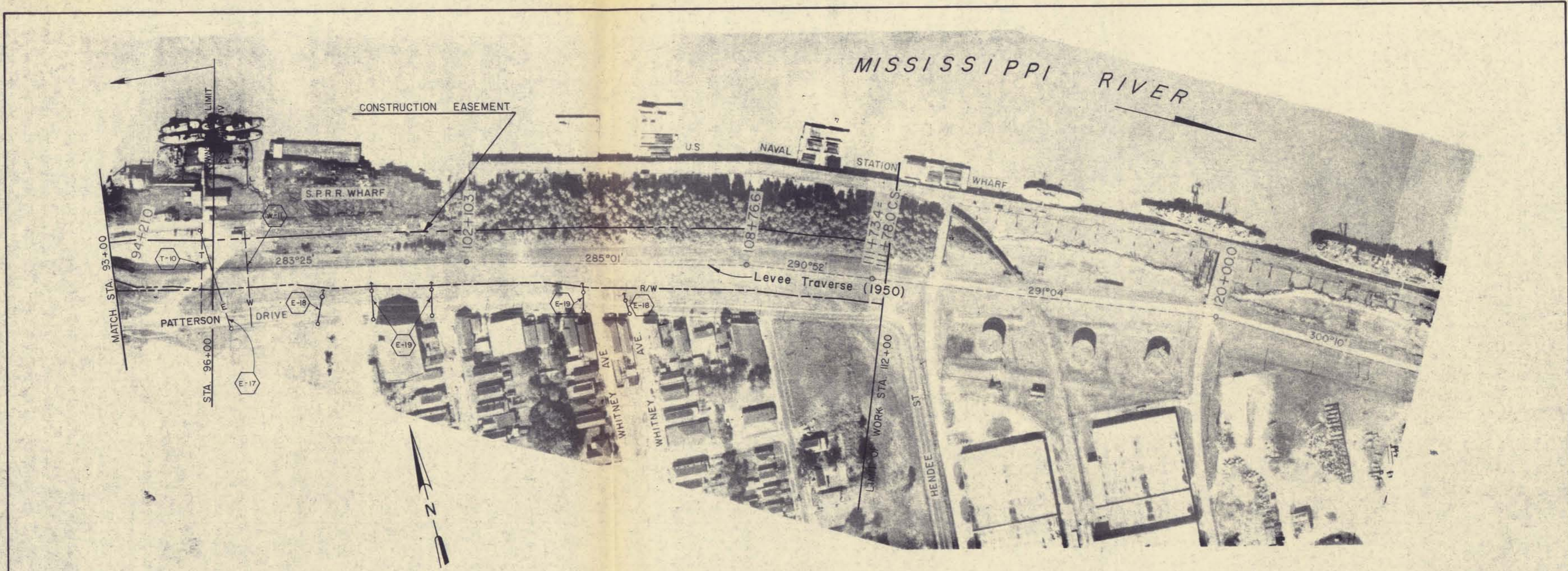

SCALE IN FEET

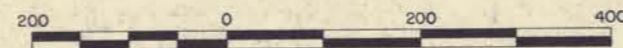

NOTE:  
 POLYCONIC PROJECTION-1927 NORTH AMERICAN DATUM.  
 CONTROLLED MOSAIC PREPARED FROM AERIAL PHOTOS  
 FLOWN NOV.-DEC. 1967.

EXISTING FACILITIES

ITEM NO	DESCRIPTION	B/L STATION	OWNER	DISPOSITION
T-10	AERIAL TELEPHONE CABLE	95+90	SOUTH CENTRAL BELL	RELOCATE
E-17	AERIAL POWERLINE	96+10	L.A. POWER & LIGHT CO.	NOT AFFECTED
W-II	WATERLINE	96+90	T. SMITH & SONS	RELOCATE
E-18	GUY POLES AND ANCHORS	98+70, 105+80	L.A. POWER & LIGHT CO.	NOT AFFECTED
E-19	" " " "	99+90, 101+80, 104+90	" " " "	RELOCATE

MISSISSIPPI RIVER AND TRIBUTARIES  
 MISSISSIPPI RIVER LEVEES  
 ITEM M-94.3-R  
 ALGIERS POINT SETBACK, LEVEE  
 ENLARGEMENT, AND SLOPE PAVEMENT  
**DESIGN MEMORANDUM NO.57**  
**RELOCATION OF FACILITIES**  
 PROJECT PLAN  
 U.S. ARMY ENGINEER DISTRICT NEW ORLEANS  
 CORPS OF ENGINEERS  
 JULY 1979 FILE NO. H-2-28506

RIVERSIDE

LANDSIDE

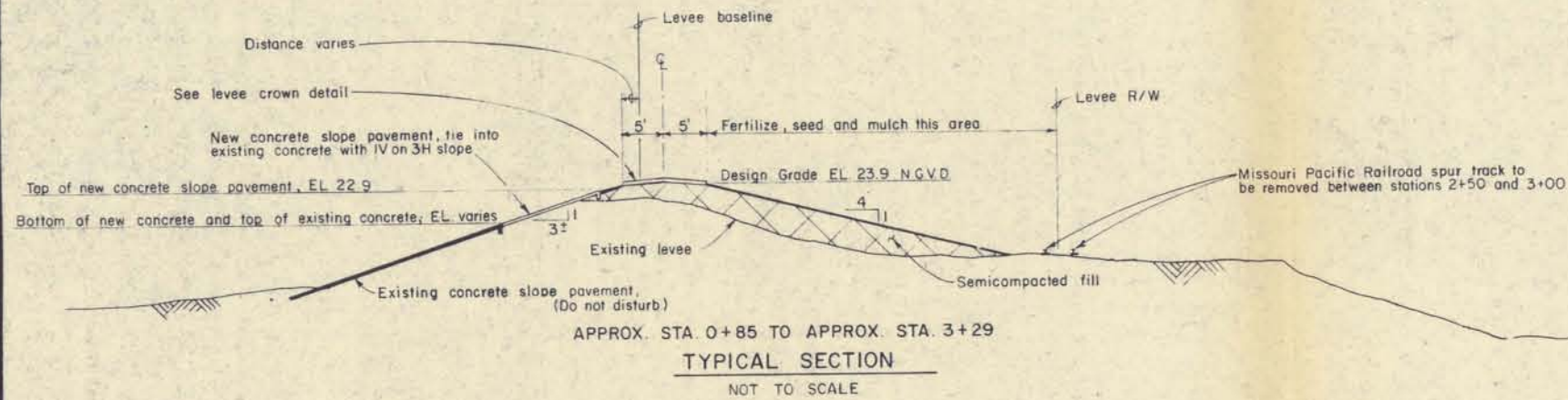

RIVERSIDE

LANDSIDE

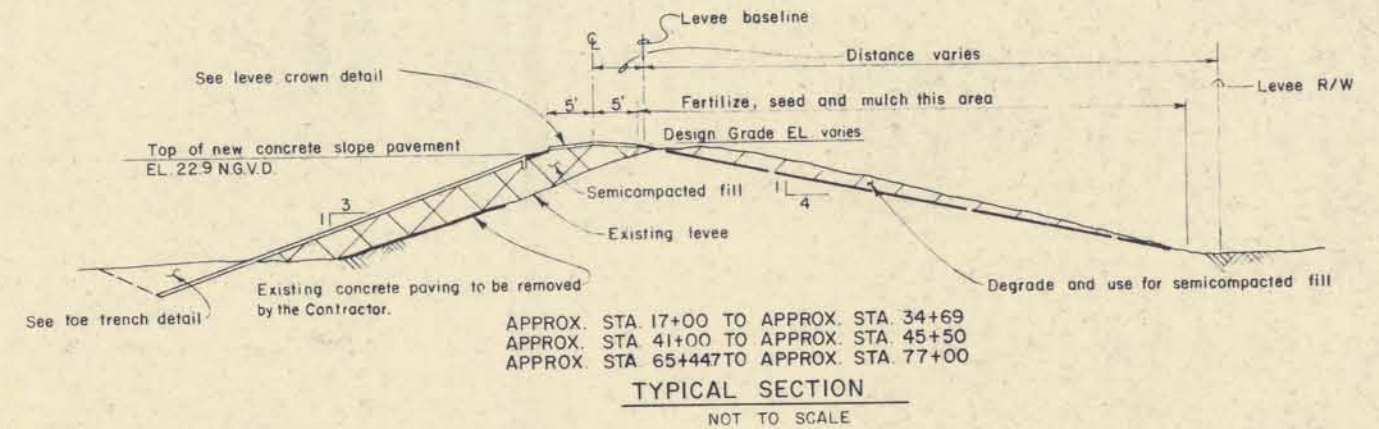

RIVERSIDE

LANDSIDE

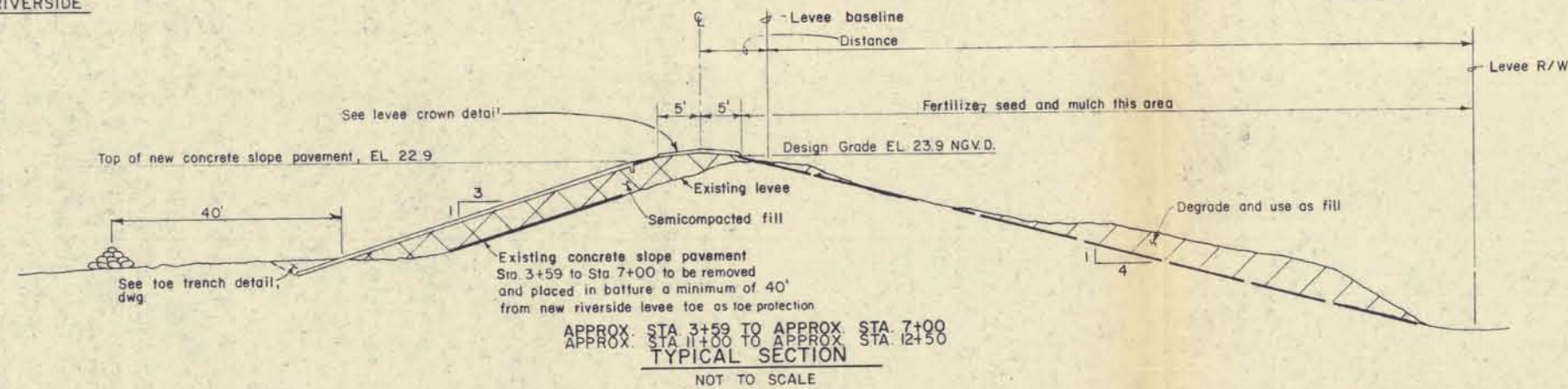

RIVERSIDE

LANDSIDE

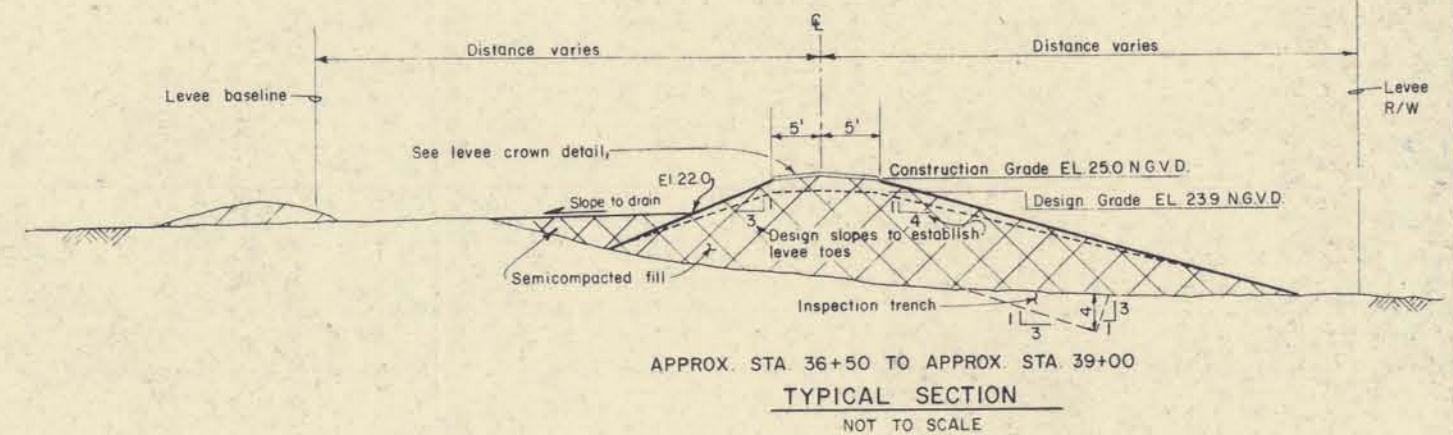

MISSISSIPPI RIVER AND TRIBUTARIES  
 MISSISSIPPI RIVER LEVEES  
 ITEM M-94.3-R  
 ALGIERS POINT SETBACK, LEVEE  
 ENLARGEMENT, AND SLOPE PAVEMENT  
**DESIGN MEMORANDUM NO.57**  
**RELOCATION OF FACILITIES**  
**TYPICAL SECTION**  
 U S ARMY ENGINEER DISTRICT NEW ORLEANS  
 CORPS OF ENGINEERS  
 JULY 1979 FILE NO. H-2-28506

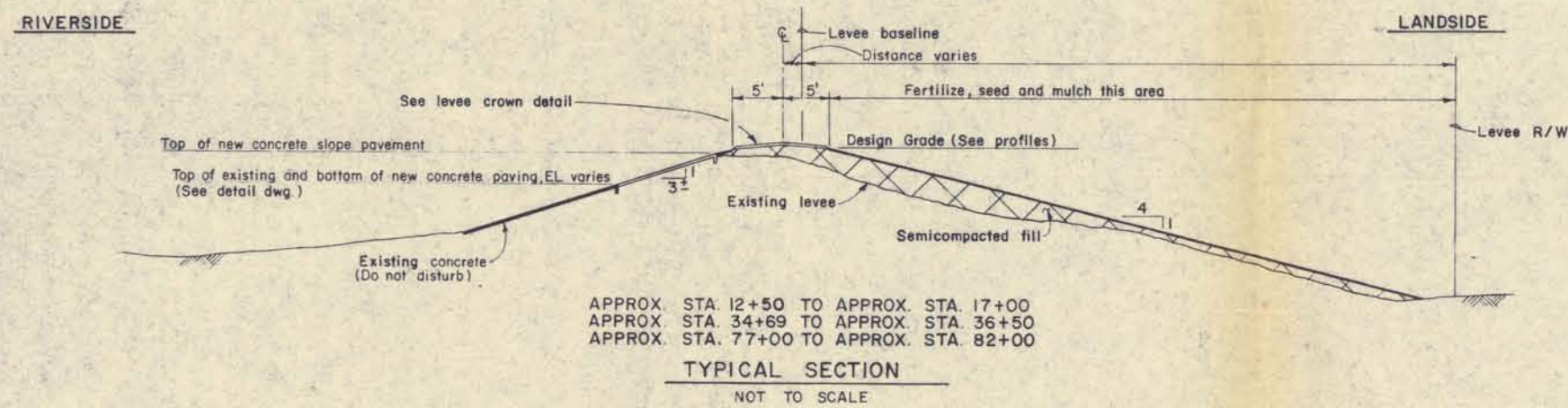
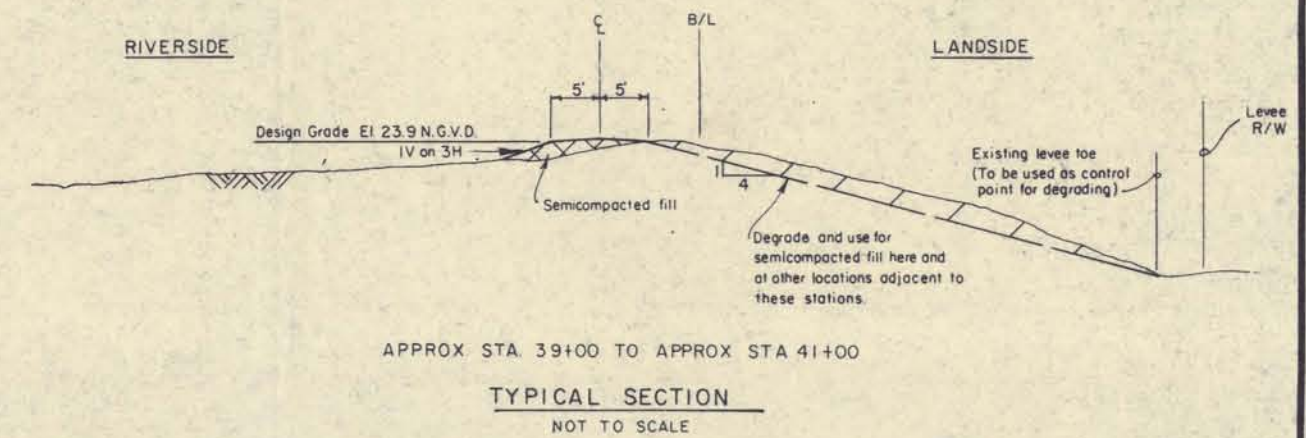
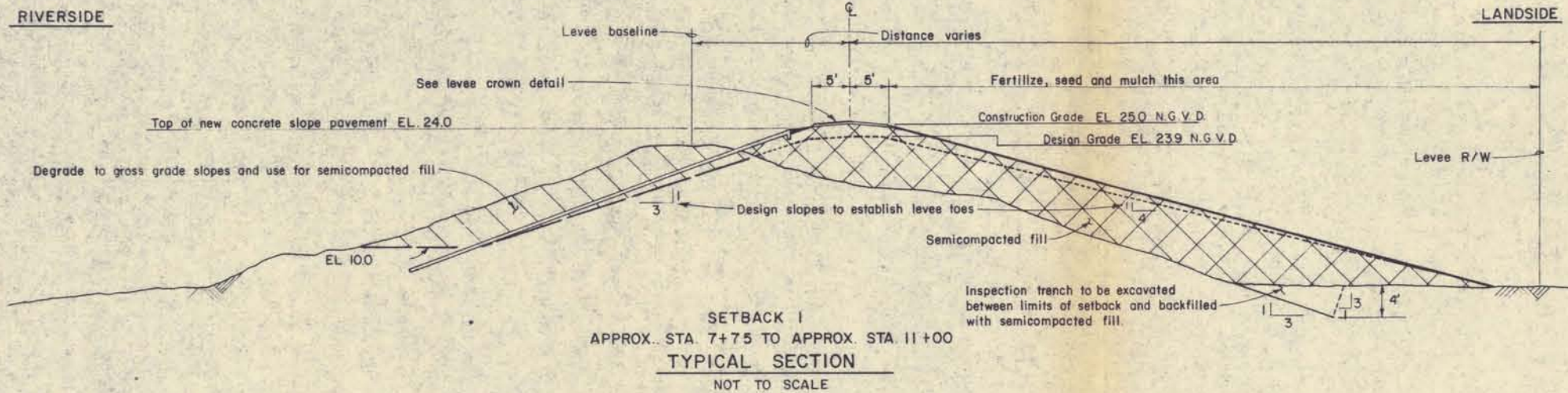

MISSISSIPPI RIVER AND TRIBUTARIES  
MISSISSIPPI RIVER - LEVEES  
ITEM M-94.3-R  
ALGIERS POINT SETBACK, LEVEE  
ENLARGEMENT, AND SLOPE PAVEMENT  
DESIGN MEMORANDUM NO. 57  
RELOCATION OF FACILITIES  
TYPICAL SECTIONS  
U S ARMY ENGINEER DISTRICT NEW ORLEANS  
CORPS OF ENGINEERS  
JULY 1979 FILE NO. H-2-28506



RIVERSIDE

LANDSIDE

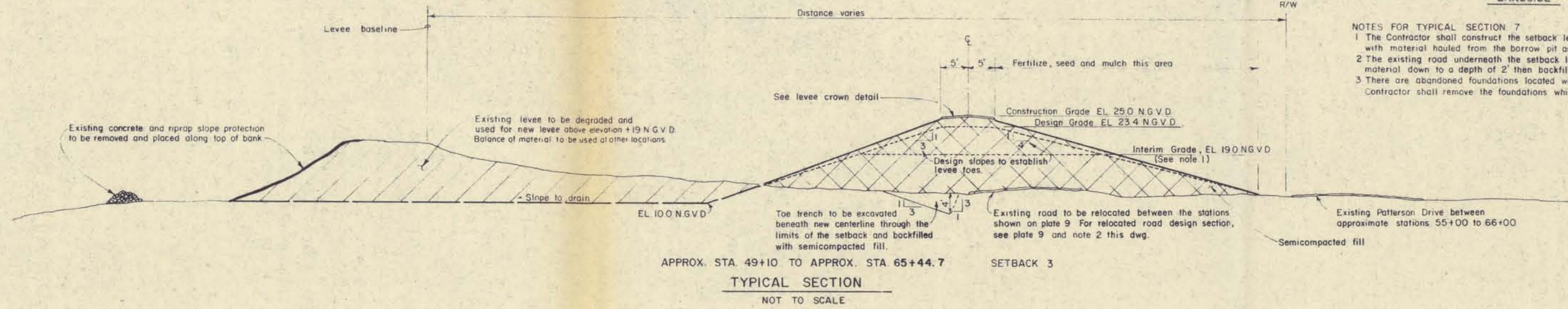

NOTES FOR TYPICAL SECTION 7  
 1 The Contractor shall construct the setback levee to the interim grade of EL 19.0 N.G.V.D. with material hauled from the borrow pit as the initial method of construction of the setback  
 2 The existing road underneath the setback levee shall be removed by excavating the road material down to a depth of 2' then backfilling with semicompacted levee embankment material  
 3 There are abandoned foundations located within the limits of this typical section. The Contractor shall remove the foundations which are located within the new levee in their entirety.

RIVERSIDE

LANDSIDE

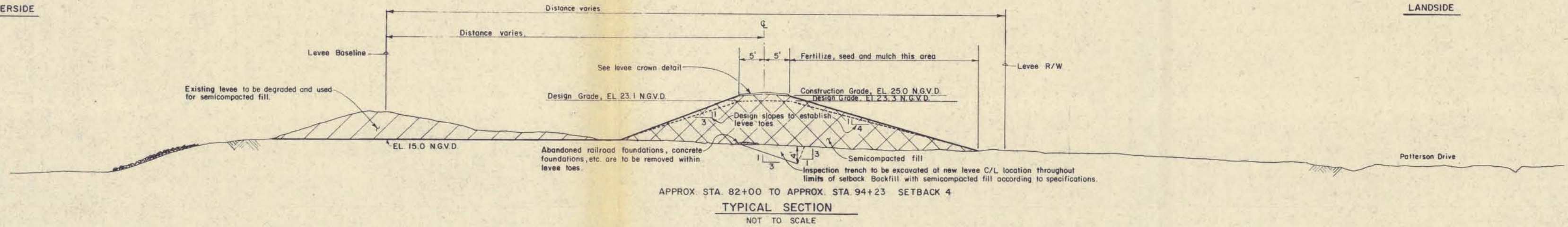

RIVERSIDE

LANDSIDE

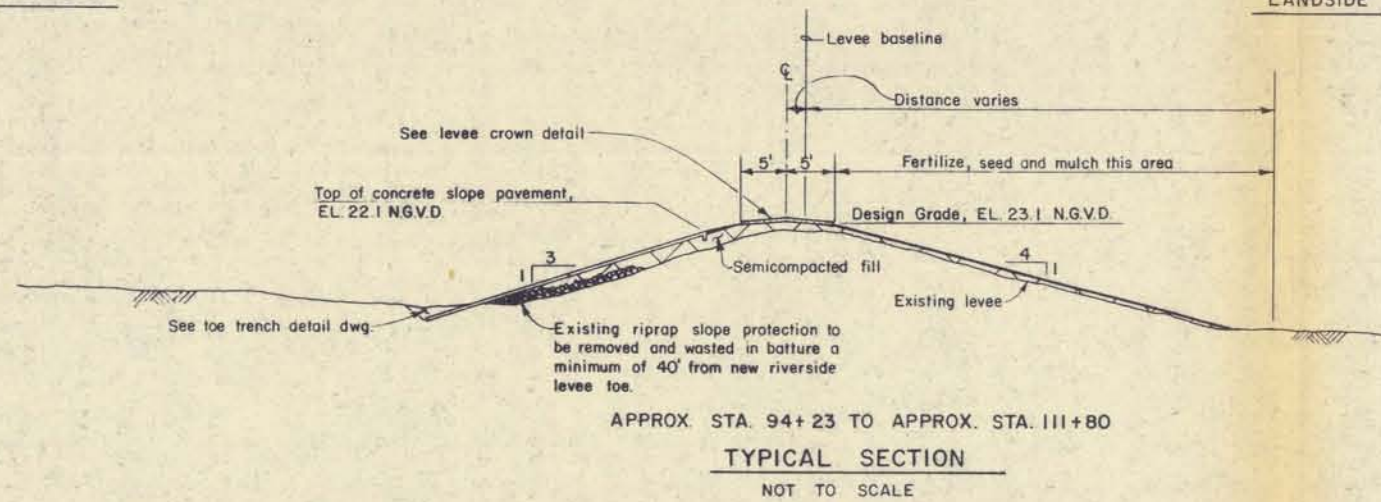

MISSISSIPPI RIVER AND TRIBUTARIES  
 MISSISSIPPI RIVER LEVEES  
 ITEM M-94.3-R  
 ALGIERS POINT SETBACK, LEVEE  
 ENLARGEMENT, AND SLOPE PAVEMENT  
 DESIGN MEMORANDUM NO.57  
 RELOCATION OF FACILITIES  
 TYPICAL SECTION  
 U S ARMY ENGINEER DISTRICT NEW ORLEANS  
 CORPS OF ENGINEERS  
 JULY 1979 FILE NO. H-2-28506

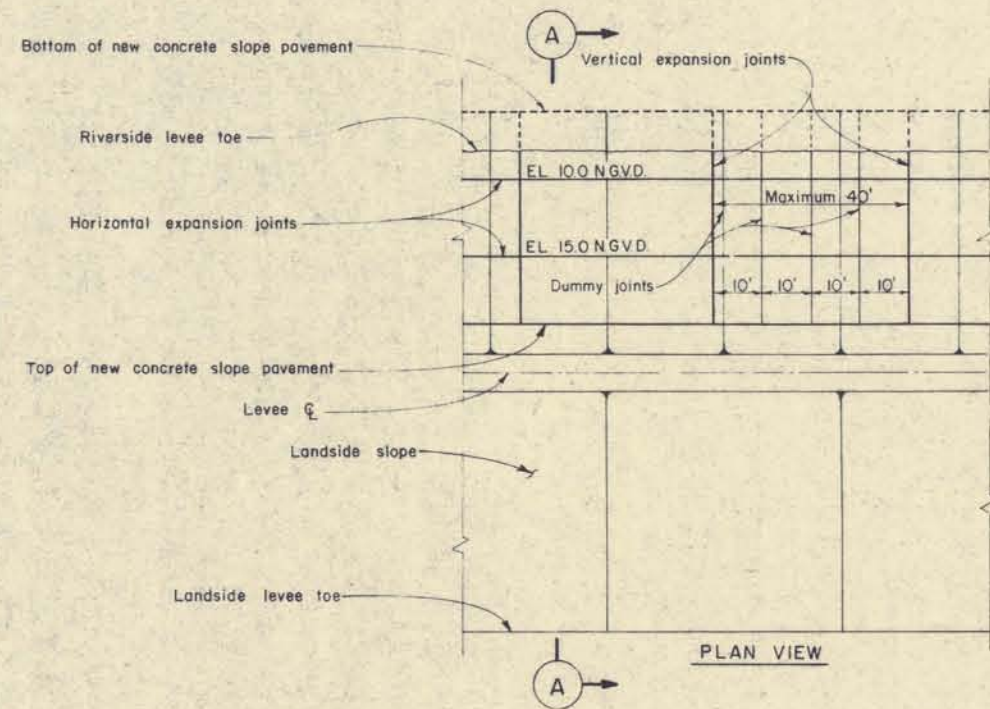

PLAN VIEW

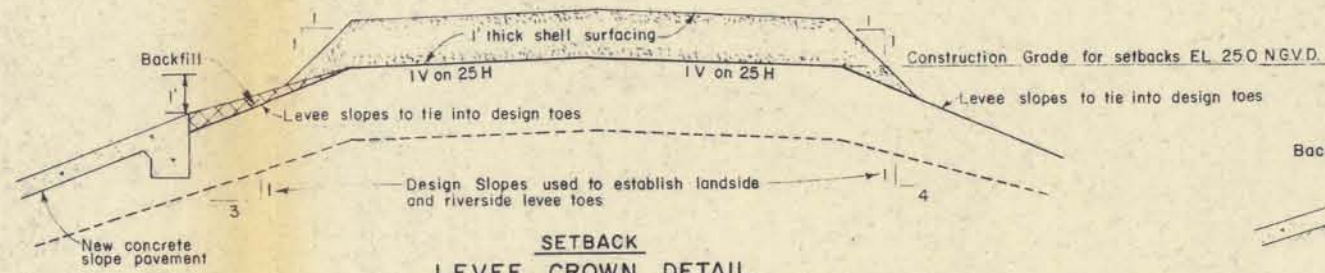

SETBACK  
LEVEE CROWN DETAIL  
NOT TO SCALE

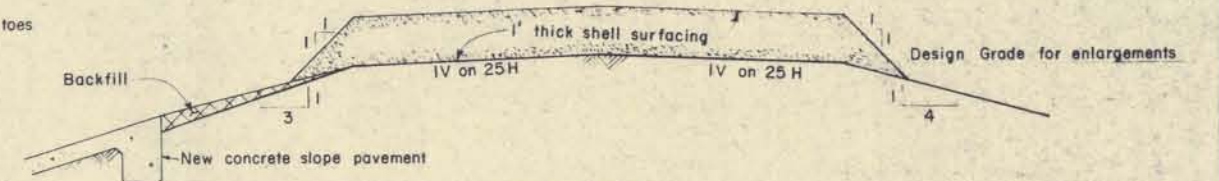

ENLARGEMENT  
LEVEE CROWN DETAIL  
NOT TO SCALE

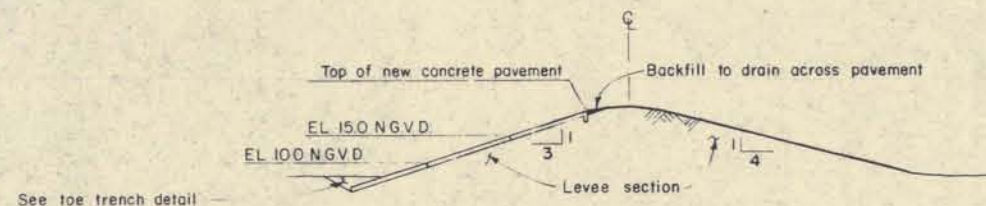

SECTION A  
CONCRETE SLOPE PAVING DETAIL  
NOT TO SCALE

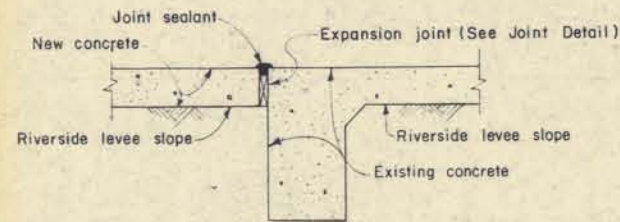

NEW TO EXISTING CONCRETE  
END CUTOFF WALL DETAIL  
NOT TO SCALE

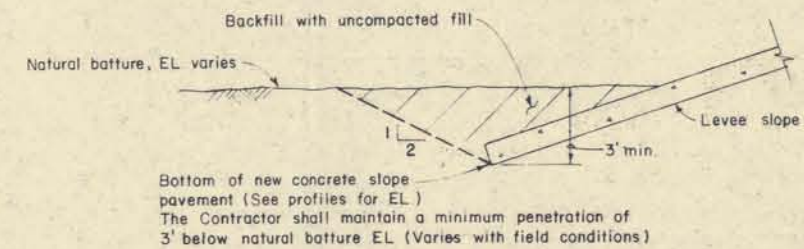

TOE TRENCH DETAIL  
NOT TO SCALE

MISSISSIPPI RIVER AND TRIBUTARIES  
MISSISSIPPI RIVER LEVEES  
ITEM M-94.3-R  
ALGIERS POINT SETBACK, LEVEE  
ENLARGEMENT, AND SLOPE PAVEMENT  
DESIGN MEMORANDUM NO.57  
RELOCATION OF FACILITIES  
CONCRETE SLOPE PAVEMENT LEVEE CROWN,  
AND TOE TRENCH DETAILS  
U S ARMY ENGINEER DISTRICT NEW ORLEANS  
CORPS OF ENGINEERS

JULY 1979

FILE NO H-2-28506

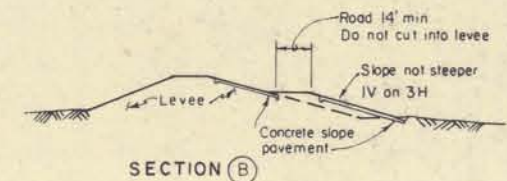
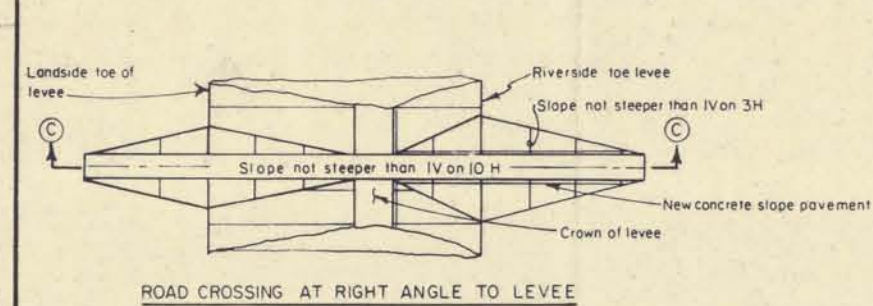
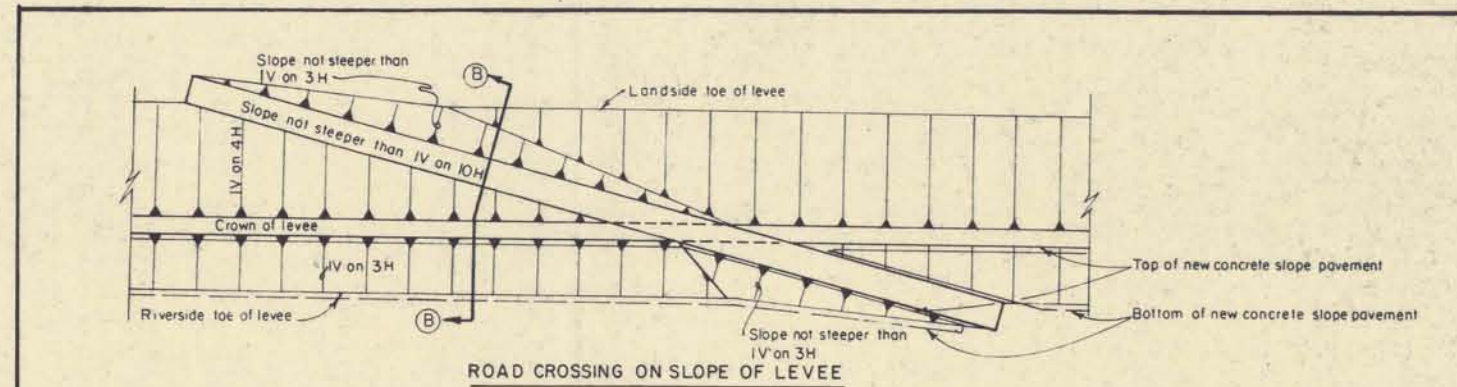
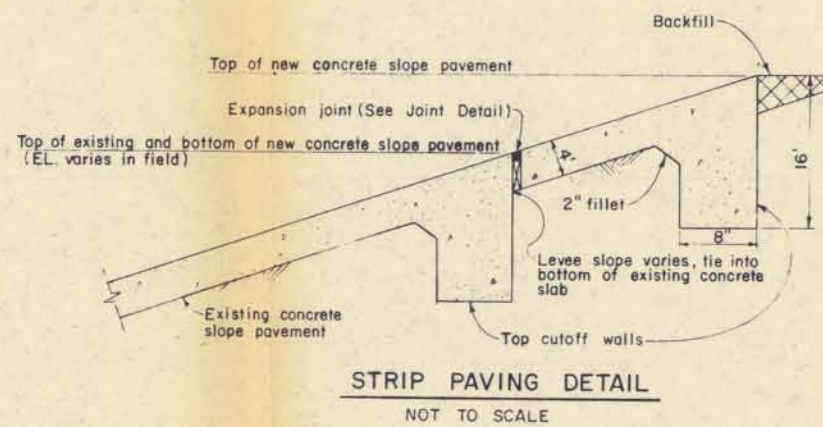
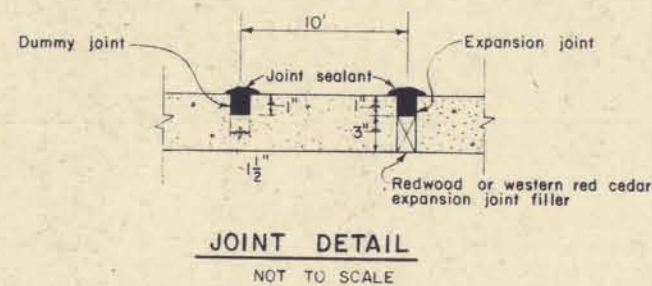
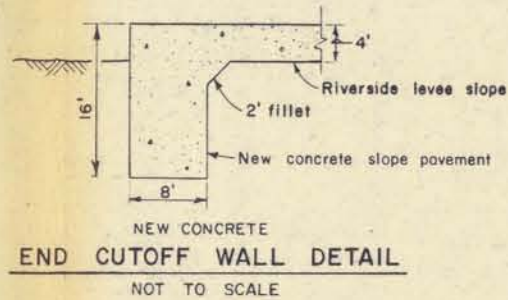
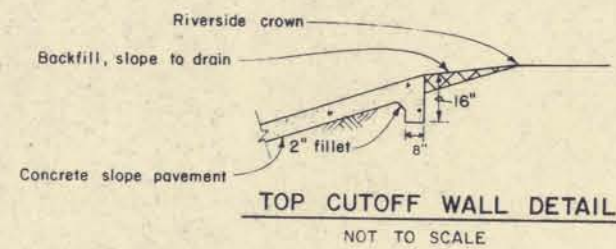

**RAMP DETAILS**  
NOT TO SCALE

MISSISSIPPI RIVER AND TRIBUTARIES  
MISSISSIPPI RIVER LEVEES  
ITEM M-94.3-R  
ALGIERS POINT SETBACK LEVEE  
ENLARGEMENT AND SLOPE PAVEMENT  
DESIGN MEMORANDUM NO.57  
**RELOCATION OF FACILITIES**  
CONCRETE SLOPE PAVEMENT LEVEE CROWN,  
AND TOE TRENCH DETAILS  
U S ARMY ENGINEER DISTRICT NEW ORLEANS  
CORPS OF ENGINEERS  
JULY 1979 FILE NO. H-2-28506

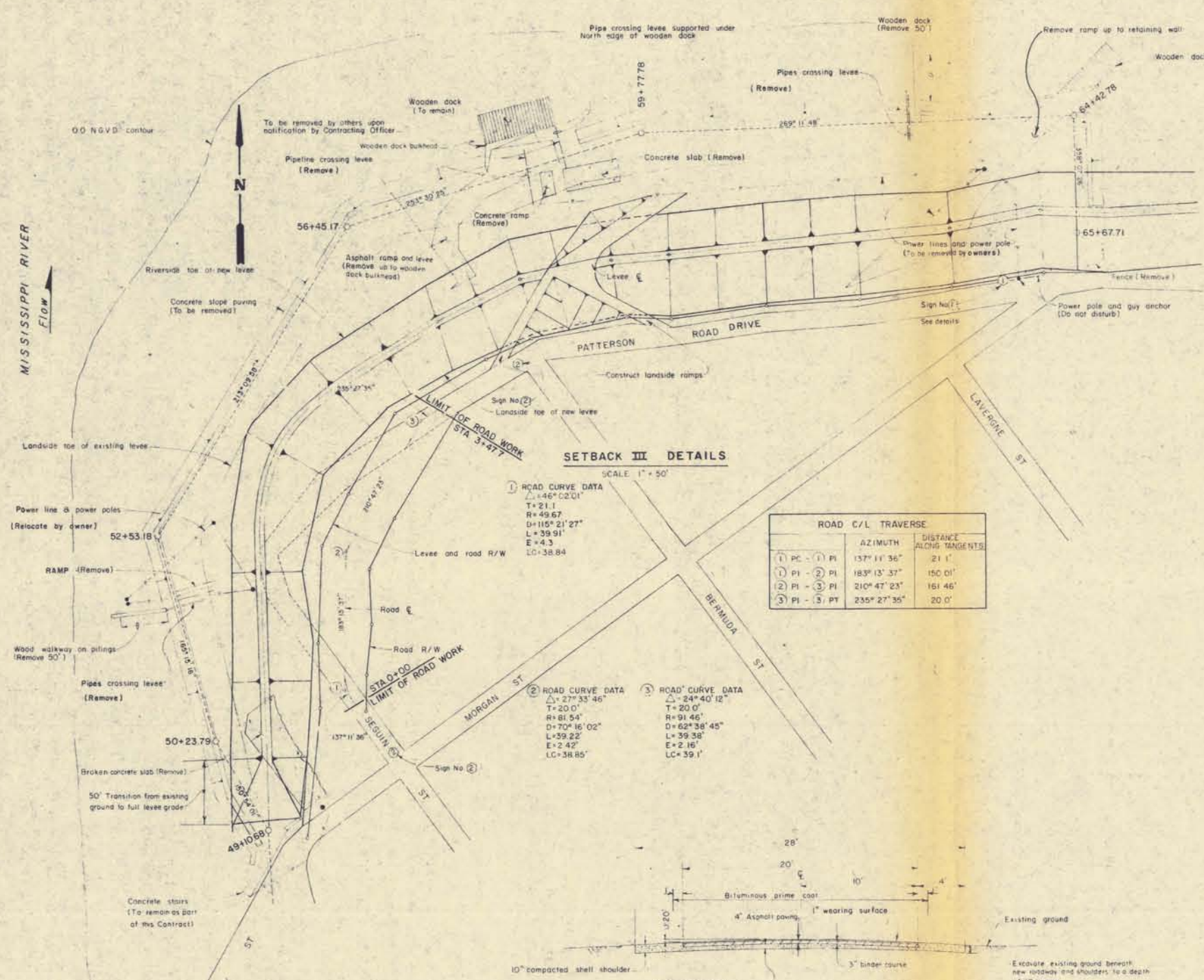

**ROAD C/L TRAVERSE**

STATION	AZIMUTH	DISTANCE ALONG TANGENTS
1 PC - 1 PI	137° 11' 36"	21.1'
1 PI - 2 PI	183° 13' 37"	150.01'
2 PI - 3 PI	210° 47' 23"	161.46'
3 PI - 3 PT	235° 27' 36"	20.0'

**TABULATION OF ROAD CENTERLINE OFFSETS**

PI	B/L STATION	ROAD C/L STATION	OFFSET	AZIMUTH
LIMIT OF WORK	PC	49+79.5	0+00	151.0
1	PI	50+00	0+21.1	146.0
	PT	50+57	0+39.91	153.9
2	PC	51+60.6	1+48.67	187.46
	PI	52+53.79	1+68.67	207.13
	PT	53+68.65	1+87.89	183.5
3	PC	54+88.98	3+08.32	178.51
	PI	55+08.97	3+28.32	177.68
	PT	55+27.48	3+47.70	185.27
LIMIT OF WORK				

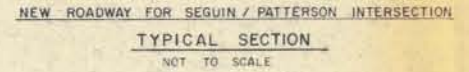

**ORDER OF WORK**  
 The levee between Sta 49+10.60 and Sta 45+67.1 shall be the first order of work for the Contractor. The levee shall be completed to full grade and section and slope paved within 3 months after notice to proceed provided the time is within low water season.

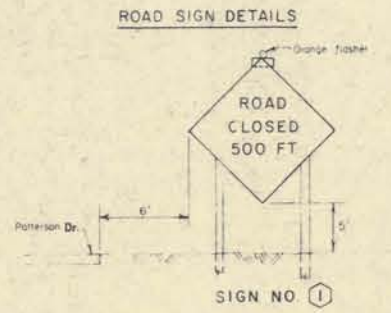

- To be used at intersection of Patterson and Morgan St.
- Sign to be located 6' riverward of riverbank edge of Patterson Dr.
- Use sign type W20-5, 48"x48"
- Use orange type A, low intensity flasher.

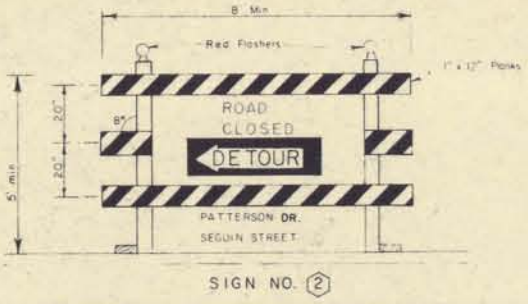

- Locate barricade in center of Patterson Drive at the upstream end of the intersection with Bermuda St. This barricade is to be located Bermuda St. on the detail scale. Use sign T11 or R11-2, 48"x30" for the Road Closed sign. Use appropriate sign type M4-10-L.
- Locate barricade in center of Seguin St on the north side of the intersection with Morgan St. Use sign type R11-2, 48"x30" for the road closed sign.
- Use red type A, low intensity, flashers.
- The barricade is a Type III Barricade.

MISSISSIPPI RIVER AND TRIBUTARIES  
 MISSISSIPPI RIVER LEVEES  
 ITEM M-94.3-R  
 ALGIERS POINT SETBACK, LEVEE  
 ENLARGEMENT, AND SLOPE PAVEMENT  
**DESIGN MEMORANDUM NO. 57**  
**RELOCATION OF FACILITIES**  
**SETBACK III DETAIL**  
 U S ARMY ENGINEER DISTRICT NEW ORLEANS  
 CORPS OF ENGINEERS  
 JULY 1979 FILE NO H-2-28506

ORDER OF WORK FOR LEVEE CONTRACTOR

- 1 Notify N O S & W B two weeks in advance of commencing in order that they can route the effluent thru the 20" line.
- 2 Submit excavation plan for removing 30" pipeline for approval by Engineering Division.
- 3 Excavate, remove and backfill hole at 30" pipeline location. Removal to include pipeline, pilebents, clips, ties, tie-downs and other miscellaneous material. Backfill to natural ground with compacted cohesive material. Excavation should take place during low water season, however, if the riverstage is above the invert of the pipe, the Contractor should provide a means of sealing the pipe on the riverside of the levee to prevent infiltration of the river into the pipe and the excavation.
- 4 Begin constructing the setback levee at station 90+00 and proceeding downstream to 95+00. Transition from existing ground to full levee between 90+00 and 90+30. Use material from borrow pit to construct interim levee to EL +19.0, material from outer levee to be used to top out levee to construction grade and slope. Place concrete slope pavement on riverside slope.
- 5 When levee is complete, notify N O S & W B so that they can begin placing new pipeline over completed levee.
- 6 Construct a temporary plug levee to EL +19.0 at station 90+17 extending from the new setback levee to the existing outer levee in order to maintain a protected system should the river rise. Use material from existing levee between stations 91+00 and 94+00 to construct plug levee.
- 7 The Contractor should begin working between stations 75+00 and 80+00 until the N O S & W B completes constructing the new sewer line crossing at station 90+60. When the sewer line work is complete the S & W B will begin routing the sewage thru the bypass line to the new sewer crossing. At that time the Contractor should begin making preparations for removal of 20" line. First order would be the submission of his excavation plan for Engineering Division review and comment. After receiving approval, he should begin excavation operations by first plugging up the sewer line on the riverside of the levee to prevent infiltration of the river into the excavation. After closing off the line, the excavation operations should commence and the pipeline, support foundations and other miscellaneous materials removed. The void shall then be backfilled to natural ground with compacted cohesive fill in one foot lifts. After backfilling is complete and accepted by the Contracting Officer, the Contractor shall begin constructing the interim setback levee from station 90+15 to 87+90, transition to full levee from 87+90 to 87+65, full levee from 87+65 to 87+05, with concrete slope paving. Transition to interim levee from 87+05 to 86+80 and interim levee from 86+80 to 83+28.21 with material hauled from the borrow pit. As soon as the interim levee is completed, the Contractor is to begin degrading the outer levee and using the material to top out the interim levee to the Construction Grade and Section shown on the dwgs. The balance of the material from the outer levee should be used to enlarge the levee from station 95+00 downstream to the limit of work in addition to material from the borrow pit.
- 8 The time duration for the work from station 90+00 to 95+00 including the plug levee is 14 days. The time duration for the work from station 83+28.21 to 90+30 is 16 days. Total time to construct the new levee, degrade the outer levee and the plug levee shall be 35 days.
- 9 The work shall not begin until N O S & W B has completed connecting a bypass line within the Patterson Drive right-of-way.

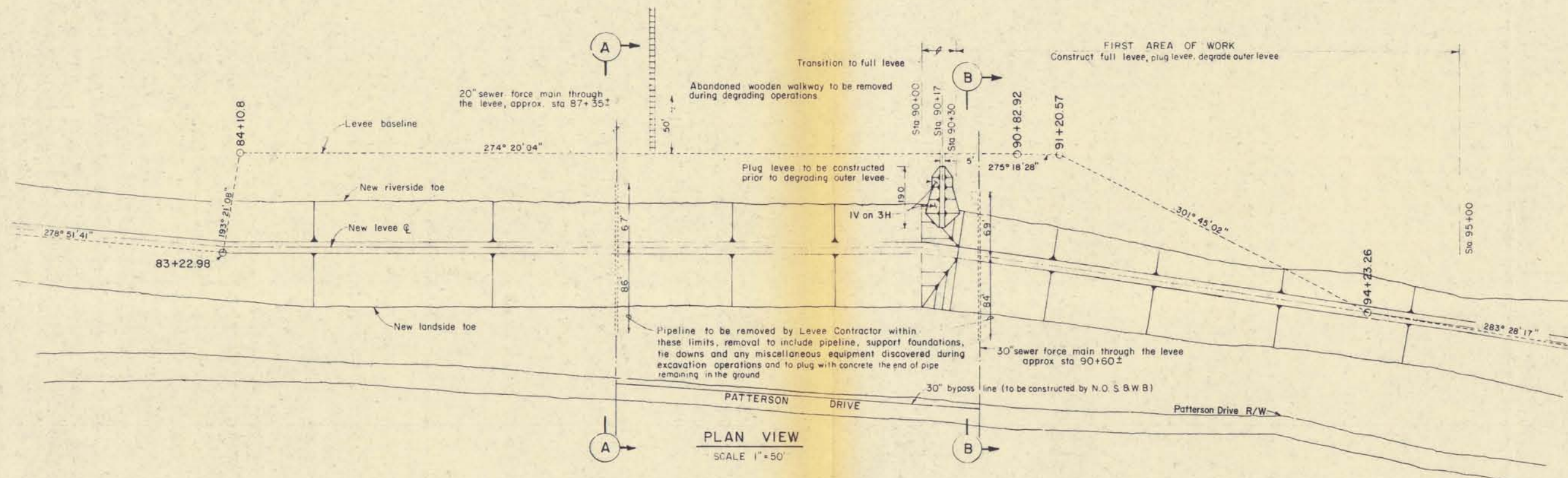

PLAN VIEW  
SCALE 1" = 50'

FOR SECTION A-A and B-B SEE PLATE 13

MISSISSIPPI RIVER AND TRIBUTARIES  
MISSISSIPPI RIVER LEVEES  
ITEM M-94.3-R  
ALGIERS POINT SETBACK, LEVEE  
ENLARGEMENT, AND SLOPE PAVEMENT  
DESIGN MEMORANDUM NO.57  
RELOCATION OF FACILITIES  
SETBACK IV DETAIL  
U S ARMY ENGINEER DISTRICT NEW ORLEANS  
CORPS OF ENGINEERS  
JULY 1979 FILE NO H-2-28506

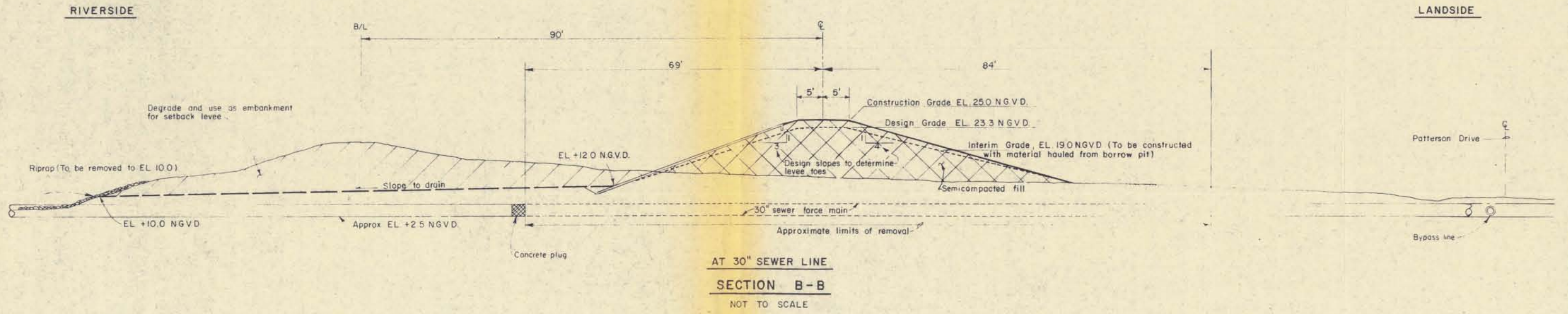
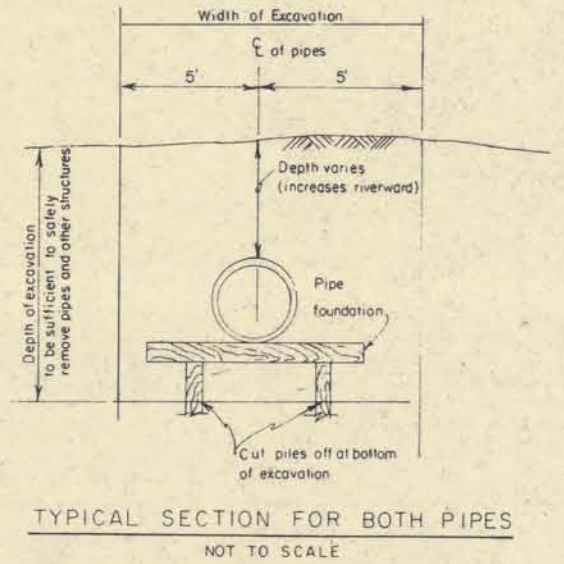
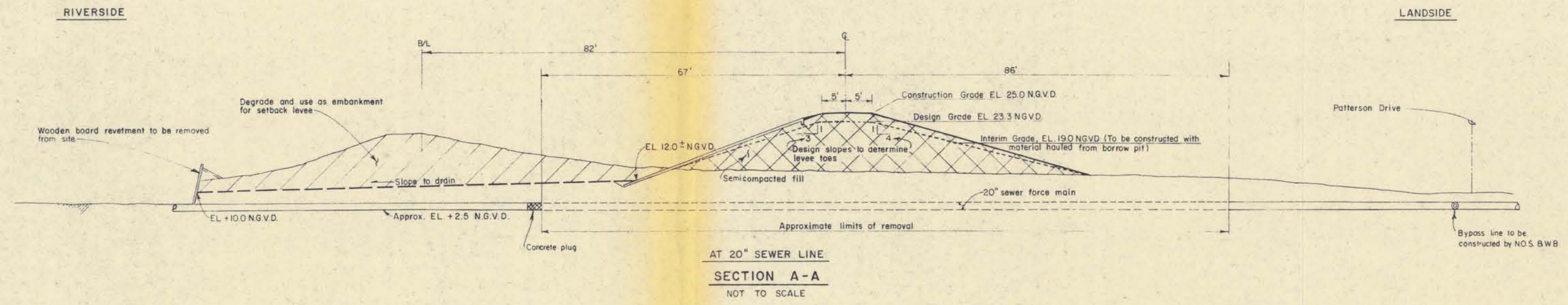

MISSISSIPPI RIVER AND TRIBUTARIES  
MISSISSIPPI RIVER LEVEES  
ITEM M-94.3-R  
ALGIERS POINT SETBACK, LEVEE  
ENLARGEMENT, AND SLOPE PAVEMENT  
DESIGN MEMORANDUM NO.57  
RELOCATION OF FACILITIES  
SETBACK IV DETAILS  
U.S. ARMY ENGINEER DISTRICT NEW ORLEANS  
CORPS OF ENGINEERS  
JULY 1979 FILE NO. H-2-28506

FLOOD CONTROL, MISSISSIPPI RIVER AND TRIBUTARIES  
MISSISSIPPI RIVER LEVEES  
ITEM M-94.3-R  
ALGIERS POINT SETBACK, LEVEE ENLARGEMENT AND SLOPE PAVEMENT  
ORLEANS PARISH, LOUISIANA  
RELOCATION OF FACILITIES  
DESIGN MEMORANDUM NO. 57

APPENDIX IA  
ATTORNEY'S REPORT

ATTORNEY'S INVESTIGATION AND REPORT OF COMPENSABLE INTEREST

ALGIERS POINT LEVEE ENLARGEMENT AND SETBACK  
ITEM M-94.3-R

This investigation and report is made in accordance with DIVR 1110-2-2 (see also DIVR 1110-2-1, 29 January 1968) and ER 1180-1-1, Section 73, Part 3, 73-203 and 73-204 on the following facility which will be affected by the Algiers Point Levee Enlargement and Setback, Item M-94.3-R.

A RAILROAD SPUR TRACT

The subject facility is located within the existing levee right-of-way as shown on the attached Exhibit "A" and by this mention made a part hereof.

The Texas-Pacific Missouri-Pacific (TP-MP) Terminal Railroad, a Louisiana Corporation, owns, operates, and maintains the subject facility. The TP-MP owns the fee simple title to the land upon which the existing levee is located, on which the spur tract is located. TP-MP acquired the fee as follows:

1. By expropriation proceedings - No. 164516, Civil District Court; Division "A", Docket 5, styled Texas Pacific, Missouri Pacific; Terminal Railroad of New Orleans vs. Louis Spiro ET. ALS., Judgement rendered 12 November 1930.

2. By a deed dated 9 March 1926, from the Title & Mortgage Guarantee Company, Limited.

COMPENSABLE INTEREST

Although the TP-MP owns the underlying fee upon which the existing right-of-way is located, it does not have a compensable interest in its facility located within the existing levee right-of-way. When TP-MP acquired the fee, the fee was acquired subject to the existing levee right-of-way. The fee was acquired in 1926 and 1930 and the levee has been in place long before 1926. A portion of the description of the fee contained in the Judgement rendered in the expropriation proceeding reads as follows:

"Part of said lots 6, 7, 8 and 9 lying between the Levee and the River."



A portion of the description of the fee contained in the deed reads as follows:

"....., said portion of ground extends to a point at or near the water's edge of the Mississippi River, and is partially covered by a levee, ....."

It is not known whether or not TP-MP has a permit from the New Orleans Levee Board (Board) or a letter of no objection from the New Orleans District Corps of Engineers, for the facility located within the existing levee right-of-way. The permits for facilities located within the existing levee right-of-way require the facilities be removed or altered at the owner's expense, if required for levee purposes. All a permit does is keep the owner of the facilities from being in trespass, it conveys no interest or right in the estate owned by the Board. Therefore, the question of a permit is moot. For if TP-MP has no permit, it is in trespass and can be required to relocate or alter its facility at its own cost, and it does not matter the length of time the facility has been in place as prescription does not run against the New Orleans Levee Board. R.S. 38:295 reads as follows:

"The prescription by which the ownership of property is acquired, as defined by Article 3458 of the Louisiana Civil Code, shall not run against any levee district of the State or against the Board of Commissioners of any levee district."

Article 3458 of the Louisiana Civil Code reads as follows:

"The prescription by which the ownership of property is acquired, is a right by which a mere possessor acquires the ownership of a thing which he possesses by the continuance of his possession during the time fixed by law."

The Board is the local cooperating agency in this instance and has the power to require TP-MP to remove its facility from the existing levee right-of-way at TP-MP's own expense under the permit if TP-MP has one, or under R.S. 38:225 (1) and (9) if TP-MP is in trespass.

#### AUTHORITY AND OBLIGATION

Authority for a construction of levee setbacks and enlargement or improvements of main line Mississippi River Levees, including berms, is contained in Act of 15 May 1928(PL 391, 70th Congress), as amended.

Neither the Board nor the Federal Government is obligated to relocate the facility of TP-MP. It is TP-MP's obligation to remove its facility at its own cost. It is the Board's responsibility to require TP-MP to remove its facility from within the existing right-of-way.

26 November 1977

  
\_\_\_\_\_  
CHESTER C. NOLAN

Attorney  
U.S. Army Engineer District  
New Orleans

FLOOD CONTROL, MISSISSIPPI RIVER AND TRIBUTARIES  
MISSISSIPPI RIVER LEVEES  
ITEM M-94.3-R  
ALGIERS POINT SETBACK, LEVEE ENLARGEMENT AND SLOPE PAVEMENT  
ORLEANS PARISH, LOUISIANA  
RELOCATION OF FACILITIES  
DESIGN MEMORANDUM NO. 57

APPENDIX IB  
ATTORNEY'S REPORT

ATTORNEY'S INVESTIGATION AND  
REPORT OF COMPENSABLE INTEREST

ALGIERS POINT SETBACK,  
LEVEE ENLARGEMENT AND SLOPE PAVEMENT,  
ITEM M-94.3-R

Mississippi River (Main Line Levee)  
Algiers, Orleans Parish, Louisiana

This investigation and report is made in accordance with DIVR 1110-2-2 (see also DIVR 1110-2-1, 29 January 1968) and ER 1180-1-1, Section 73, Part 3, 73-203 and 73-204 on the facilities listed in Exhibit "A" attached hereto and by this mention made a part hereof, which will be affected by the Algiers Point Setback, Levee Enlargement and Slope Pavement.

All of the facilities listed on Exhibit "A" are indicated on map file No. H-2-28506 in Design Memorandum No. 57 styled Mississippi River and Tributaries, Mississippi River Levees, Item M-94.3-R, Algiers Point Setback Levee Enlargement and Slope Pavement, Design Memorandum No. 57, Relocation of Facilities, Project Plan, U. S. Army Engineer District, New Orleans Corps of Engineers,

(A)  
Compensable Interest  
of

- (1) The Sewerage and Water Board of New Orleans (SWB)
- (2) The City of New Orleans (NO)

The SWB and NO own, operate and maintain the facilities listed under paragraphs (a) and (i) of Exhibit A.

1. SWB is a public utility, (LSA-RS 33:4161). The SWB is owned by NO (LSA-RS 33:4071). LSA-RS 33:4078 gives NO the right of expropriation of other property rights when convenient or necessary for the acquisition of any property for its sewerage, water and drainage system.

The SWB as of this date has not produced any permits involved in placing its facilities within the rights-of-way of the dedicated public streets. If the SWB's facilities are located within the city streets without a permit, they are in trespass against the city and no one else.

Inasmuch as subject relocations are not for the improvement of the streets, but for levee purposes, the usual required agreement of a permittee, or what would usually be required of a trespasser, such as this utility corporation that it relocate at its expense, when necessary for the convenience of the street, is not applicable under the guideline commonly accepted and used in circumstances similar to subject levee project.

If a utility is located on privately owned land, but within the right-of-way of a public street under a permit form, or as trespasser against the municipality, and must be relocated to accommodate levee construction instead of ordered to be removed for the convenience of the street, then the utility is located on privately owned fee lands despite its location within the street right-of-way limits.

In this instance, the SWB's facilities located on and under the dedicated streets, on privately owned fee land, are being dislocated, not for street convenience or needs, but for levee purposes.

Therefore, in view of the foregoing, it is considered that the SWB has a compensable interest in all of its facilities listed in paragraph (a) Exhibit "A", excepting therefrom any facility or portion thereof which is located within the existing levee right-of-way or on or in the batture.

2. NO is a municipal corporation of the State of Louisiana. NO holds in trust for the public, fee title, not merely an easement or servitude to its streets, and it may, pursuant to LSA-RS 42:2 and LSA-RS 33:4717, upon a two-thirds vote of the City Council, revoke the destination or dedication of such property and sell at private sale, exchange or otherwise convey to the United States, the State of Louisiana or any department or agency of either, such property needed for public use. NO's fee title in its streets has been repeatedly recognized by the Louisiana Supreme Court, together with its right to alienate such interest therein.

There is no record as to how NO acquired the right-of-way for its facilities listed under paragraph (i), were acquired. However, a corporation with the right of eminent domain possesses a vested right in the right-of-way to be relocated, even without conventional negotiation for an acquisition of such required servitudes, as was decreed in a long line of decisions by the Louisiana Supreme Court,

St. Julien v. Morgan's Louisiana & T. R. Co., 35th La. Tate v. Town of Ville Platte, 44 SO 2d 360. This servitude is commonly referred to as the doctrine of "Unopposed Occupancy" or "Unopposed Use". Therefore, in view of the foregoing, NO has a compensable interest in its facilities listed under paragraph (i) of Exhibit "A" excepting therefrom any facility or portion thereof which is located within the existing levee right-of-way.

Special attention is called to the necessity of compliance, in any act of divestiture or surrender of a right or title, by NO the requirements of LSA-RS 33:4717, must be met. That is, such act is to be by formal conveyance, or similar act of transfer, authorized by appropriate ordinance adopted by a two-thirds vote of the City Council.

(B)  
Compensable Interest  
of  
The Board of Commissioners of the  
Port of New Orleans (Dock Board)

The Dock Board, an agency of the State of Louisiana, owns, operates and maintains the facilities listed under (b) on Exhibit "A".

Article LSA-RS 34:33 provides, inter alia: "The Board of Commissioners may acquire by purchase or by expropriation in accordance with the expropriation laws, any property, wharves or landing necessary

for the benefit of the commerce of the port and harbor of New Orleans....."

It is unknown as to how the Dock Board acquired its right-of-way for its facilities. However, a corporation with the right of eminent domain possesses a vested right in the right-of-way to be relocated under the doctrine of "Unopposes Occupancy" or "Unopposed Use:", (see Section A (2) above). The Dock Board has a compensable interest in all of its facilities listed under paragraph (b) on Exhibit "A".

(C)  
Compensable Interest  
of

1. South Central Bell Telephone Company (S.C.B.)
2. Louisiana Power and Light Company (L.P.&L.)
3. New Orleans Public Service, Inc., (N.O.P.S.I.)

S.C.B. is a Delaware Corporation duly authorized to do business in the State of Louisiana.

L.P. & L. and N.O.P.S.I. are Louisiana corporations, domiciled in New Orleans, Louisiana.

All three of the above named corporations are privately owned public utility companies. LRS-RS 45:265 and 45:121 respectively.

All three corporations have the power of eminent domain (expropriation) LRS-Article 19, sections 2(7) and 2(9) respectively.

S.C.B. and N.O.P.S.I. have not furnished any evidence that the subject rights-of-way were purchased from the fee owner. However, as



as stated above (paragraph A(2)), a corporation with power of eminent domain, possesses a vested right in the right-of-way to be relocated, even without conventional negotiation for and acquisition of such required servitudes. All three corporations have a compensable interest in and to its facilities listed herein, excepting therefrom any facility or portions thereof which is located within the existing levee right-of-way, or on or in the batture.

(D)  
Compensable Interest  
of

1. Eastern Associates Terminals (E.A.T.)
2. Algiers Iron Works (A.I.W.)
3. T. Smith & Sons, Inc. (Smith)

E.A.T. is a Delaware corporation duly authorized to do business in the State of Louisiana. A.I.W. and Smith are Louisiana corporations. None of the aforementioned companies are considered to be public utilities or common carriers and therefore they are not under the control of the Louisiana Public Service Commission. The E.A.T., A.I.W. and Smith have a compensable interest in their facilities listed in paragraphs (f), (g) and (h) of Exhibit "A". However, the aforementioned corporations do not have a compensable interest in any of their facilities that are located within the existing levee right-of-way or on or in the batture. These facilities will be acquired as part of the real estate acquisition program for the project.

(E)  
Compensable Interest  
of  
Unknown Owners

Abandoned Facilities

Those facilities that are indicated in Exhibit "A" as not being used may be considered as having been abandoned by the owners.

The just compensation for these facilities is the cost of removal.

To constitute abandonment of personal property by the owner thereof, so as to give another a right to assume title to control of property, there must be an act of abandonment by owner with the intention to abandon. Crowell Land and Mineral Corp. v. United States, 114 F. Supp. 31; Powell v. Cox, 92 S.O. 2d 739. Therefore, the owners of the various facilities, if known, should be requested to furnish a letter of intent or it should be set forth in a relocation contract as to which facilities will be abandoned.

Batture Defined

Batture is that part of the riverbed which is uncovered at time of low water, but is covered annually at the time of ordinary high water; when it ceases to be covered at time of ordinary high water it ceases to be batture, and becomes the bank of the river. Boyce Cottonseed Oil Mfg. Co., v. Board of Commissioners of Red River, Atchafalaya and Bayou Boeuf Levee District, 160 La. 727, 107 S.O. 506.

Banks Defined

Civil Code, article 457, provides as follows:

"The banks of a river or stream are understood to be that which contains it in its ordinary state of high water; for the nature of the banks does not change, although for some cause they may be overflowed for a time.

Nevertheless on the borders of the Mississippi and other navigable streams, where there are levees, established according to law, the levees shall form the banks."

Under this article levees established according to law on the borders of the Mississippi and other navigable streams form the banks of the river. Ward v. Board of Levee Commissioners of Orleans Levee District, 152 La. 158, 92 SO. 769, 43 S. Ct. 246, 260 U.S. 745.

#### Authority and Obligation

Authority for a construction of levee setbacks of mainline Mississippi River Levees is contained in the Act of 15 May 1928 (P 2 391, 70th Congress), as amended. Payment or reimbursement of costs to local cooperating agencies for rights-of-way furnished including necessary relocation or alteration of public roads, highways, railroads, public utilities, and pipelines is authorized by the Flood Control Act of 18 August 1941 (PL 228, 77th Congress, 1st Session), as amended by the Flood Control Act of 22 December 1944 (PL 534, 78th Congress, 2d Session).

In those cases where the local cooperating agency is not financially able to arrange for relocation or alteration of interfering facilities, subject to reimbursement of costs, the District Engineer is authorized to enter into a contract with the facility owner, subject to the requirements of ER 1180-1-1.

Authority for construction, enlargement, or improvement of mainline Mississippi River Levees, including berms, is contained in the Act of 15 May 1928 (PL 391, 70th Congress) as amended. The furnishing of right-of-way for levee foundations and levees on the main stem Mississippi River, except levee setbacks, is an obligation of local interests (see Section 3, Act of 15 May 1928). The replacement or relocation of public roads, highways, railroads, public utilities, and pipelines required for the construction of mainline Mississippi River Levees will be accomplished at Federal expense. Reimbursement of costs to local cooperating agencies in perfecting relocation of interfering facilities may be made pursuant to the Act of 23 April 1934 (PL 171, 73d Congress).

NOTE  
LACK OF COMPENSABLE INTEREST  
CIVIL WORKS

Where a public utility will be destroyed or damaged due to operation of a civil works project and relocation or alteration of the facility is required to continue service to the public, the Government may assume the cost of relocating or altering the facility (but not the cost for a new right-of-way) when, in fact, the utility owner is not presently vested with a compensable interest in the existing right-of-way. Negotiations with utility owners in accordance with the foregoing are authorized under Section 2, Flood

Control Act of 1938 (52 Stat. 1215; 33 U.S.C. 701c-1). (See Comp. Gen. Decision B-134242, 24 December 1957).

Therefore, in view of the foregoing authorization, the Government may assume the cost of relocating items A(1), A(2), but not the cost for the new rights-of-way.

On 10 July 1978, Senate Bill No. 807 became effective. The said bill amended and reenacted Section 281 of Title 38 of the Revised Statutes of 1950, relative to levees and levee drainage, to provide for measure of compensation for lands and improvements, Orleans Parish excepted, actually used, damaged or destroyed for levees or levee drainage purposes. Section 281 provides inter alia the following: "B. All lands and improvements, Orleans Parish excepted, hereafter actually used, damaged or destroyed for levees or levee drainage purposes shall be paid for fair market value to the full extent of the loss, and just compensation for both the land and improvements taken a destroyed and for damages suffered by reason thereof, shall be paid to the owner or into the court for his benefit." (Emphasis Added)

Date:

21 August 1978   
CHESTER C. NOLAN  
Attorney  
Office of Counsel (Real Estate Division)  
U. S. Army Engineer District, New Orleans

Exhibit "A"

ALGIERS POINT SETBACK,  
LEVEE ENLARGEMENT AND SLOPE PAVEMENT,  
ITEM M-94.3-R

a. The Sewerage & Water Board of New Orleans owns facilities which will be dislocated by the subject project, as listed below:

<u>Item</u>	<u>Type</u>	<u>Baseline Station</u>	<u>Plate</u>
<u>Setback Limits</u>			
W-2	Water intake	11+25	2
W-5	Waterline	50+80 to 54+20	3A
S-1	Sewer outfall	87+58	4
S-2	Sewer outfall	90+58	4
S-3	Sewerline	53+50 to 54+20	3A

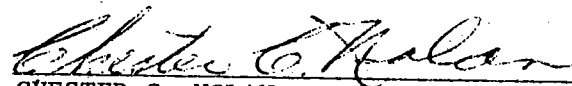
Enlargement Limits

E-9	Underground electric Cable	44+90	3A
-----	-------------------------------	-------	----

b. The Board of Commissioners of the Port of New Orleans owns facilities which will be dislocated by the subject project, as listed below:

<u>Item</u>	<u>Type</u>	<u>Baseline Station</u>	<u>Plate</u>
<u>Enlargement Limits</u>			
W-8	Waterline	64+40	4
<u>Setback Limits</u>			
WW-1	Walkway	51+75	3
W-6	Waterline	51+70	3A
W-7	Waterline	58+60	3A
G-4	Gasline	51+75	3

c. South Central Bell Company owns telephone facilities which will be dislocated by the subject project, as listed below:

<u>Item</u>	<u>Type</u>	<u>Baseline Station</u>	<u>Plate</u>
<u>Enlargement Limits</u>			
T-1	6 underground cables	22+85	2
T-2	Aerial cable	30+00	3
T-4	4 underground cables & relay boxes	44+30	3
T-7	1 underground cable	72+85	4
T-8	Aerial cable & poles	73+00 to 77+00	4

Setback Limits

T-3	Aerial & underground cable	38+10 to 39+43	3
T-5	Cable & poles	50+23 to 52+53	3
T-6	Underground cable	58+10	3
T-9	Aerial cable	83+70	4
T-10	Aerial cable	95+90	5

d. Louisiana Power and Light Company owns facilities which will be dislocated by the subject project, as listed below:

<u>Item</u>	<u>Type</u>	<u>Baseline Station</u>	<u>Plate</u>
-------------	-------------	-----------------------------	--------------

Enlargement Limits

E-3	Powerline & pole	19+15	2
E-4	Powerline & poles	22+96 to 24+28	2
E-6	Powerline & poles	30+10	3A
E-7	Powerline & poles	38+10 to 45+40	3A
E-8	Underground cable	40+25	3A
E-12	Powerline & poles	69+05	4
E-13	Powerline & pole	70+85	4
E-14	Guy wire	80+00	4
E-17	Powerline & pole	96+10	5



Setback Limits

E-1	2-power poles	10+18 & 1142	2
E-7	Powerline & poles	38+10 to 45+40	3A
E-10	Powerline & poles	50+23 to 58+00	3A
E-11	Powerline & poles	63+50	4
E-15	Powerline & poles	83+70	4
E-16	Guy pole & Attachment	87+23	4

e. New Orleans Public Service, Inc. owns gas facilities which will be dislocated by the subject project, as listed below:

<u>Item</u>	<u>Type</u>	<u>Baseline Station</u>	<u>Plate</u>
-------------	-------------	-----------------------------	--------------

Setback Limits

G-2	Gas meter	39+25	3
G-5	Gasline	58+25	3

f. Eastern Associates Terminals owns facilities which will be dislocated by the subject project, as listed below:

<u>Item</u>	<u>Type</u>	<u>Baseline Station</u>	<u>Plate</u>
-------------	-------------	-----------------------------	--------------

Enlargement Limits

P-1	Pipeline	23+80 to 27+00	2
G-1	Gasline	26+90	3
W-3	Waterline	30+05	3A

g. Algiers Iron Works owns facilities which will be dislocated by the subject project, as listed below:

<u>Item</u>	<u>Type</u>	<u>Baseline Station</u>	<u>Plate</u>
<u>Setback Limits</u>			
W-4	Waterline	39+25	3A
G-3	Gasline	39+25	3
CR-1	Crane Tracks	39+43	3

h. T. Smith & Sons, Inc. owns facilities which will be dislocated by the subject project, as listed below:

<u>Item</u>	<u>Type</u>	<u>Baseline Station</u>	<u>Plate</u>
<u>Enlargement Limits</u>			
W-9	Waterline	80+10	4
W-11	Waterline	96+90	5
<u>Setback Limits</u>			
W-10	Waterline	83+00	4

i. The City of New Orleans owns Seguin and Patterson Streets which will be dislocated by the subject project from baseline station 50+23 to baseline station 55+00. These two streets intersect at the toe of the existing levee and will be referred to as one relocation (item R-1, plate 3).

j. The ownerships of the following abandoned facilities which will be dislocated by the subject project are unknown:

<u>Item</u>	<u>Type</u>	<u>Baseline Station</u>	<u>Plate</u>
<u>Enlargement Limits</u>			
E-2	3 Power poles	12+54, 14+14 & 15+65	2
E-5	3 Power poles	22+95, 24+13 & 25+13	2

FLOOD CONTROL, MISSISSIPPI RIVER AND TRIBUTARIES  
MISSISSIPPI RIVER LEVEES  
ITEM M-94.3-R  
ALGIERS POINT SETBACK, LEVEE ENLARGEMENT AND SLOPE PAVEMENT  
ORLEANS PARISH, LOUISIANA  
RELOCATION OF FACILITIES  
DESIGN MEMORANDUM NO. 57

APPENDIX II  
COST ESTIMATES

TABLE 4 - ESTIMATE OF COST  
 CITY OF NEW ORLEANS - ROADS  
 (JULY 1979 PRICE LEVELS)

MAINTENANCE FUNDS

<u>Description</u>	<u>Amount (\$)</u>
Item R-1, 350 linear feet of asphalt-paved City streets (Seguin St. and Patterson Drive	24,000 <sup>1</sup>
Contingencies (25%+)	<u>6,000</u>
Subtotal	30,000
Right-of-way	<u>56,000<sup>2</sup></u>
Subtotal Federal Cost	86,000
E & D (6%+)	2,000 <sup>3</sup>
S & A (6%+)	<u>2,000<sup>3</sup></u>
TOTAL	90,000

<sup>1</sup>Based on excavating and removing existing roadway surface and base material, excavating existing ground beneath new roadway and shoulders, constructing the new asphalt-paved road and shoulders, and all traffic controls and signal devices for accomplishing the work.

<sup>2</sup>Based on actual funds obligated to date for road right-of-way (\$55,900).

<sup>3</sup>No E & D or S & A for right-of-way.

TABLE 5 - ESTIMATE OF COST  
SEWERAGE AND WATER BOARD OF NEW ORLEANS  
UTILITIES  
(JULY 1979 PRICE LEVELS)

CONSTRUCTION FUNDS

<u>Description</u>	<u>AMOUNT (\$)</u>
Item E-9, 300 linear feet of double-armored 6.6 kV buried power cable	30,000 <sup>1</sup>
Contingencies (25%+)	<u>8,000</u>
Subtotal Federal Cost	38,000 <sup>2</sup>
E & D (6%+)	2,500
S & A (6%+)	<u>2,500</u>
TOTAL	<u>43,000</u>

<sup>1</sup>Includes construction of approximately 40 linear feet of levee to full design grade and section including a 15 foot wide strip of concrete slope pavement on the riverside slope of the levee. The relocated cable will be placed over the enlarged levee, and it will be encased in concrete.

<sup>2</sup>No salvage credit on old cable; it will be removed and discarded. No depreciation based on ECI 73-209.3(b)(1)b, change 21, dated 20 February 1974. No betterment since replacement cable will be built to the same capacity and equivalent engineering criteria as that possessed by the existing cable.

TABLE 6 - ESTIMATE OF COST  
 SEWERAGE AND WATER BOARD OF NEW ORLEANS  
 UTILITIES  
 (JULY 1979 PRICE LEVELS)

MAINTENANCE FUNDS

<u>Description</u>	<u>Amount (\$)</u>
Item W-5 cut and abandon existing water main; construct 350 linear feet of 6" diameter cast iron water main under new Seguin Street and Patterson Drive; construct new fire hydrant (work by S&WB)	8,000 <sup>1</sup>
Item W-5, excavate and remove 420 linear feet of abandoned 6" diameter cast iron pipe under existing Seguin Street and Patterson Drive (work by Government's contractor)	2,000 <sup>2</sup>
Items S-1 and S-2, construct 310 linear feet of 30" diameter steel sewer force main (bypass line between item S-1 and item S-2) plus valves and fittings (work by S&WB)	110,000 <sup>1</sup>
Items S-1 and S-2, excavate, cut and plug existing 20" and 30" sewer mains; remove 125 linear feet of existing mains (work by S&WB)	4,000

Items S-1 and S-2, construct 400 linear feet each of 20" diameter and 30" diameter steel sewer force mains over completed levee; install valves and fittings (work by S&WB)	220,000 <sup>1</sup>
Items S-1 and S-2, excavate, cut and remove 250 linear feet of existing sewer mains and pipe supports from under area to be occupied by the new levee (work by Government's contractor)	7,000 <sup>2</sup>
Item S-3, cut and abandon existing 8" diameter sewer main and manhole; construct new manhole at Patterson Drive (work by S&WB)	3,000 <sup>2</sup>
Item S-3, excavate and remove 180 linear of abandoned 8" diameter sewer main and 1 manhole (work by Government's contractor)	2,000 <sup>2</sup>
Subtotal	356,000
Contingencies (25%+)	<u>89,000</u>
Subtotal Federal Cost	445,000
E & D (6%+)	27,000
S & A (6%+)	<u>27,000</u>
TOTAL	<u>499,000</u>



<sup>1</sup>No depreciaton based on ECI 73-209.3 (b)(1)b, change 21, dated 20 February 1974. No betterments since the replacement facilities will be built to the same capacities and equivalent engineering criteria as that possessed by the existing facilities.

<sup>2</sup>No Salvage credit is due. The old facilities will be discarded as junk.

TABLE 7 - ESTIMATE OF COST

BOARD OF COMMISSIONERS OF THE  
PORT OF NEW ORLEANS - DOCK BOARD

UTILITIES

(JULY 1979 PRICE LEVELS)

MAINTENANCE FUNDS

<u>Description</u>	<u>Amount (\$)</u>
Item WW-1, remove abandoned dock and timber walkway at existing fire boat landing (work by Government's contractor)	3,000
Item W-6, excavate and remove 200 linear feet of 6" diameter waterline at existing fire boat landing (work by Government's contractor)	2,000
Items WW-1, W-6, W-7, and W-8 temporary facilities (docking facilities and water supply) for fire boats and Bermuda St. Wharf for duration of levee contract (work by Dock Board)	10,000
Item G-4, excavate and remove 250 linear feet of 2" diameter gasline (work by Government's contractor)	1,000
Item W-7, Item W-8, construct 200 linear feet each of 4" diameter and 6" diameter waterline at Bermuda St. Wharf, including installation of meters (work by Dock Board)	18,000

Subtotal	34,000
Contingencies (25%+)	<u>9,000</u>
Subtotal Federal Cost	43,000
E & D (6%+)	3,000
S & A (6%+)	<u>3,000</u>
TOTAL	<u>49,000</u>

TABLE 8 - ESTIMATE OF COST

LOUISIANA POWER AND LIGHT COMPANY - UTILITIES

(JULY 1979 PRICE LEVELS)

<u>Description</u>	<u>Amount (\$)</u>
Items E-4, E-7, E-10, E-11, E-14, E-15, E-16 and E-19; relocate, remove or adjust poles, guys, anchors, conduct- ors, transformers, etc. to accommodate the project	\$13,000 <sup>1</sup>
Contingencies (25%+)	<u>3,000</u>
Subtotal Federal Cost	16,000 <sup>2,3</sup>
E & D (6%+)	1,000
S & A (6%+)	<u>1,000</u>
TOTAL	<u>18,000</u>

<sup>1</sup>Represents compensable portion of these items. The relocations cost of items E-1, E-12, E-13, and E-14 are entirely at the owner's expense.

<sup>2</sup>Construction funds = \$8,000; maintenance funds = \$8,000.

<sup>3</sup>No salvage or betterment credit; existing materials will be reused.